

DIAX02 Plug-In Modules for Digital Intelligent Drive Controllers

Project Planning Manual

DOK-DIAX02-PLUG*IN*MOD-PRJ1-EN-P



Title	DIAX02 Plug-in module for digital intelligent drive controllers
Type of documentation	Project Planning Manual
Document code	DOK-DIAX02-PLUG*IN*MOD-PRJ1-EN-P
Internal file reference	<ul style="list-style-type: none"> • Mappe 11a / Register R • 209-0076-4305-01
The purpose of this documentaiton	<p>This document supports electronic construction at the machine manufacturer.</p> <p>The technical data, terminal diagrams and signal paths for the individual plug-in modules have been compiled here for that purpose.</p>

Editing sequence

Document designation of previous editions	Status	Comments
209-0069-4356-00	Oct. 93	1st edition
209-0069-4356-01	May 95	
DOK-DIAX02-PLUG*IN*MOD-PRJ1-EN-P	March 97	new edition

Copyright	<p>© INDRAMAT GmbH, 1993</p> <p>Copying this document and giving it to others and the use or communication of the contents hereof without express authority, are forbidden. Offenders are liable for the payment of damages. All rights reserved in the event of the grant of a patent or the registration of a utility model or design. (DIN 34-1)</p>
Validity	All rights are reserved with respect to the content of this documentation and the availability of the product.
Published by	<p>INDRAMAT GmbH • Bgm.-Dr.-Nebel-Str. 2 • D-97816 Lohr a. Main</p> <p>Telefon 09352/40-0 • Tx 689421 • Fax 09352/40-4885</p> <p>Abt. ENA (JH)</p>

Contents

1 About This Document	1-1
1.1 Areas of Use of the Plug-In Modules.....	1-1
2 Storage and Transport Conditions of the Plug-In Modules	2-1
2.1 Storage and Transport Conditions of the Plug-In Modules.....	2-1
3 Mechanical Design of the Plug-In Modules	3-1
3.1 Plug-In Modules with Plastic and Metal Front Plates.....	3-1
3.2 Type Codes	3-2
4 Ground Reference of the Plug-In Module Connections	4-1
4.1 Low-voltage loops DC 5...24 V and galvanically coupled signal inputs and outputs	4-1
4.2 Optocoupler Interface	4-1
4.3 Notes on Earth-Fault Monitoring.....	4-2
5 Control Card CLC-D01.1A-FW	5-1
5.1 Terminal Diagram CLC-D01.1A-FW.....	5-1
6 Control card CLC-D02.1A-FW and CLC-D02.3A-FW	6-1
6.1 Terminal Diagram CLC-D02.1A-FW and CLC-D02.3A-FW	6-1
7 ANALOG interface with Absolute Encoder Emulator DAA01.1	7-1
7.1 General Information.....	7-1
7.2 Terminal Diagram DAA01.1.....	7-2
7.3 Technical Data.....	7-3
8 ANALOG interface with Incremental encoder emulator DAE01.1	8-1
8.1 General Information.....	8-1
8.2 Terminal Diagram DAE01.1.....	8-2
8.3 Technical Data.....	8-3
9 ARCNET Coupler Card DAK01.1A	9-1
9.1 Connecting an ARCNET Coupler Card DAK01.1A.....	9-1
10 INTERBUS-S interface module DBS02.1-FW	10-1
10.1 General Information.....	10-1
10.2 Terminal Diagram.....	10-2
10.3 Technical Data.....	10-3
INTERBUS-S	10-3

External Inputs	10-3
11 INTERBUS-S - interface module DBS02.2-FW	11-1
11.1 General Information	11-1
11.2 Terminal Diagram	11-2
11.3 Technical Data	11-3
INTERBUS-S	11-3
External inputs	11-3
12 INTERBUS-S Slave Module DBS03.1-FW	12-1
12.1 General Information	12-1
12.2 Terminal Diagram	12-1
12.3 Technical Data	12-2
INTERBUS-S	12-2
External inputs	12-2
13 Input / output interface DEA04.1, DEA05.1, DEA06.1	13-1
13.1 General Information	13-1
13.2 Terminal Diagram	13-2
13.3 Technical Data - DEA04.1, DEA05.1, DEA06.1	13-3
14 Input / output interface DEA04.2, DEA05.2, DEA06.2	14-1
14.1 General Information	14-1
14.2 Terminal Diagram	14-2
14.3 Technical Data - DEA04.2, DEA05.2, DEA06.2	14-3
15 Input / output interface DEA28.1, DEA29.1, DEA30.1	15-1
15.1 General Information	15-1
15.2 Terminal Diagram	15-2
15.3 Technical data - DEA28.1, DEA29.1, DEA30.1	15-3
16 Position Interface for Square-Wave Signals DEF01.1 and DEF02.1	16-1
16.1 General Information	16-1
16.2 DEF01.1 and DEF02.1 Connector Assignments	16-1
16.3 Technical data - DEF01.1 and DEF02.1	16-2
17 Encoder Interface DFF01.1	17-1
17.1 General Information	17-1
17.2 Terminal Diagram	17-2
18 Positioning Module DLC01.1	18-1
18.1 General Information	18-1
18.2 Terminal Diagram	18-1
19 Positioning Module DLC02.1-FW	19-1
19.1 General Information	19-1
19.2 Terminal Diagram	19-2

20 High-Resolution Position Interface for Sine Signals DLF01.1	20-1
20.1 General Information.....	20-1
20.2 Terminal diagrams.....	20-2
20.3 Technical data - DLF01.1	20-4
21 Profibus Interface DPF02.1/03.1/04.1	21-1
21.1 General Information.....	21-1
21.2 Terminal Diagram.....	21-2
21.3 Technical Data.....	21-3
22 Profibus Interface DPF05.1-FW	22-1
22.1 General Information.....	22-1
22.2 Terminal Diagram.....	22-1
22.3 Technical Data.....	22-2
23 Analog Signal Interface DRF01.1	23-1
23.1 General Information.....	23-1
23.2 Terminal Diagram DRF01.1.....	23-1
23.3 Technical data - DRF01.1.....	23-2
24 Summer Input Interface DSE01.1	24-1
24.1 General Information.....	24-1
24.2 Terminal Diagram.....	24-3
24.3 Technical data - DSE01.1.....	24-4
24.4 Start-Ups.....	24-6
25 SERCOS interface DSS01.1	25-1
25.1 General Information.....	25-1
25.2 Terminal Diagram.....	25-1
25.3 Technical data - DSS01.1.....	25-2
26 SERCOS interface DSS01.3	26-1
26.1 General Information.....	26-1
26.2 Terminal Diagram.....	26-1
26.3 Technical data - DSS01.3.....	26-2
27 Gear Encoder Interface DZF01.1	27-1
27.1 General Information.....	27-1
27.2 Terminal Diagram.....	27-1
27.3 Power supply of the external measuring system	27-2
28 Gear Encoder Interface DZF02.1	28-1
28.1 General Information.....	28-1
28.2 Terminal Diagram.....	28-1
28.3 Power supply of the external measuring system	28-2
29 Plug-In Module Accessories	29-1

29.1 Encoder Branching DGA01.2 for encoders with sinusoidal $1V_{SS}$ voltage signals 29-1

 General Information 29-1

 Terminal Diagram 29-2

 Dimensional sheet - DGA01.2 29-3

 Technical Data 29-3

29.2 Line Driver DGV01.1 for Measuring Systems with Current Signals..... 29-6

 Terminal Diagram - Line driver DGV01.1 29-6

 Dimensional sheet - Line driver DGV01.1 29-6

30 Index

30-1

1 About This Document

1.1 Areas of Use of the Plug-In Modules

The plug-in modules documented here are intended for use in digital drive controllers belonging to the DIAX02 drive family.

Depending on the selected configured drive controller, various plug-in modules can be inserted into the slots of the drive controller.

Which plug-in module can be combined with which software is outlined in the document "Drive Configurations".

Notes:

2 Storage and Transport Conditions of the Plug-In Modules

2.1 Storage and Transport Conditions of the Plug-In Modules

Protection against electrostatic loads

Electrostatic loads endanger electronic components. Objects that come into contact with components and printed circuit boards must be discharged by grounding. For example,

- the human body by touching a conductive, grounded object
- the soldering iron when soldering
- parts and tools must be placed on a conductive surface

Note: Such endangered parts as, e.g., the plug-in modules may only be stored and shipped in conductive packaging.

Temperature and Humidity

Ambient temperature during operation	+5...+45°C
Ambient temperature during storage and transport	-30...+85°C
Allowable relative humidity	max. 95%
Allowable absolute humidity	max. 25g water/m ³

Fig. 2-1: Allowable Temperature and Humidity

Notes:

3 Mechanical Design of the Plug-In Modules

3.1 Plug-In Modules with Plastic and Metal front plates

The plug-in modules for drive controllers belonging to the DIAX03 and DIAX04 drive families have a metal front plate with two knurled screws (top and bottom) (see Fig. 3-1).

The plug-in modules for drive controllers belonging to the DIAX03 and DIAX04 drive families (see Fig. 3-1) can therefore not be inserted into drive controllers of the DIAX03 drive family as the plug-in module cannot be mounted into the drive controller.

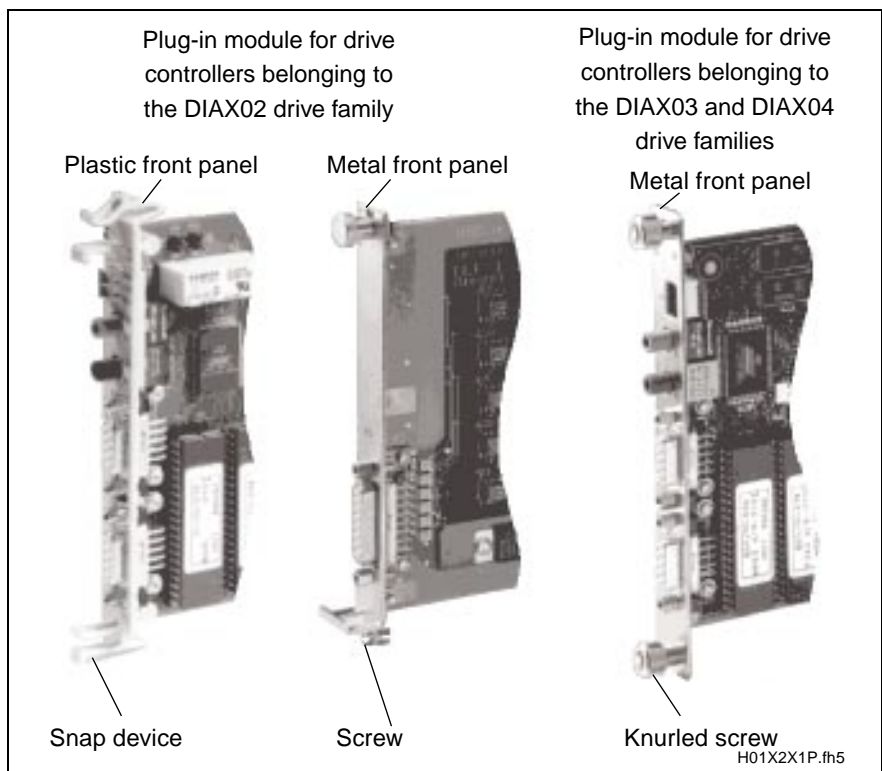

Fig. 3-1: Plug-in module with plastic and metal front plates

3.2 Type Codes

The plug-in module type code has been placed at the top of the front plate. The type designation can cover two lines. The designation -FW is not on the front plate of the plug-in module. This designation specifies that the plug-in module is equipped with firmware.

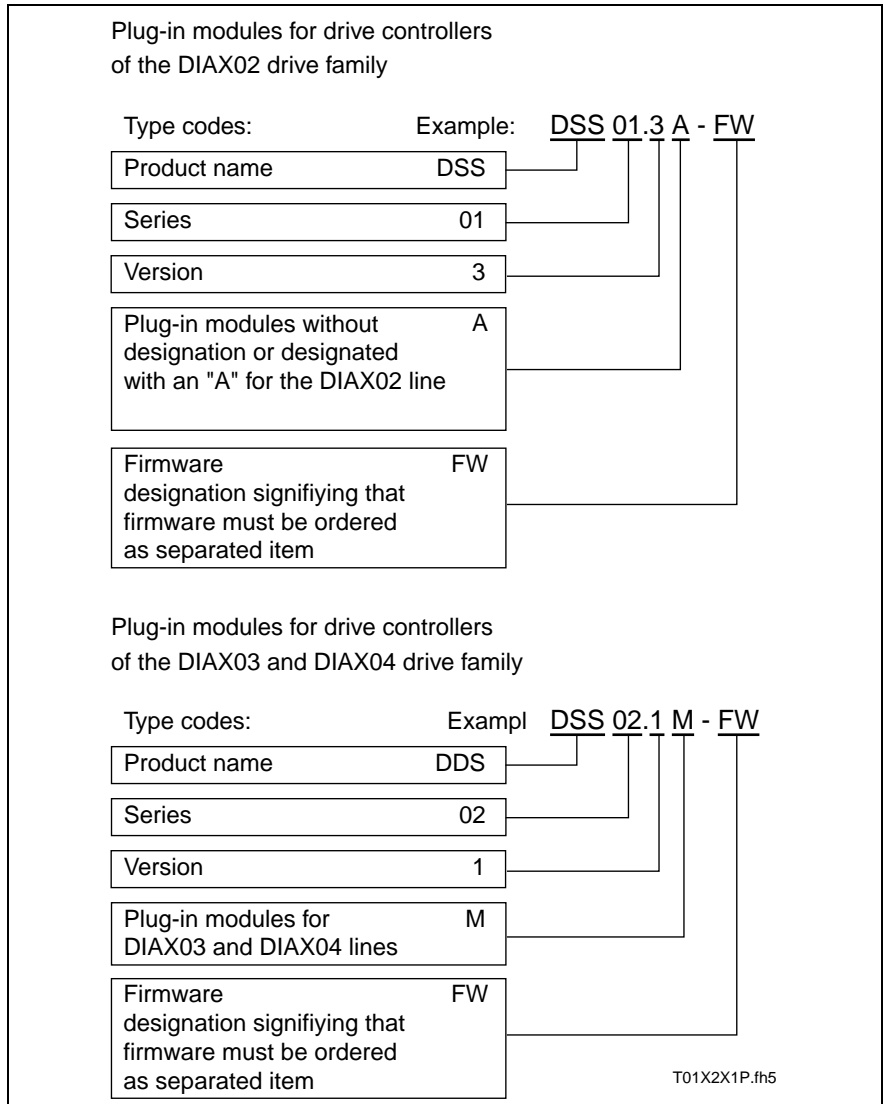

Fig. 3-2: Type code

4 Ground Reference of the Plug-In Module Connections

4.1 Low-voltage loops DC 5...24 V and galvanically coupled signal inputs and outputs

All connections and terminals with voltages of between 5 and 50 volts in INDRAMAT products are protective extra-low voltages (PELV = Protective Extra Low Voltage).

They are contact protected in terms of the following standards:

- international: IEC 364-4-411.1.5
- European countries within the EU: EN 50178/1994, section 5.2.8.1.

These connections are grounded electric circuits. The reference potential of these circuits designated 0VM, GND or 0VL at the supply unit is connected with the housing and thus grounded. The signal connections and terminals of the drive controllers are a part of these circuits.

A separation of the ground connection is -- even for test purposes -- not possible for reasons of safety. If these circuits are isolated from the housing (ground potential), then a proper functioning of the electronic components could no longer be guaranteed.

Which connections this applies to is specified in the terminal diagram of the electrical equipment.

4.2 Optocoupler Interface

The extra-low voltage loops (e.g., DC 24 V) for operating the plug-in modules must be grounded, i.e., the OV potential must be connected to the central earth point in the control cabinet. Even if the DC 24 V electric circuits of the plug-in modules are generally galvanically isolated, this grounding still remains necessary (see Fig. 4-1).

Every day use has shown that a non-grounded voltage loop can transmit interference signals, under some circumstances, via the coupler capacity of the optocoupler. This, in turn, can generate error messages in the drive.

The galvanic isolation of the plug-in modules which implements the optocoupler prevents AC/DC currents from being conducted over the evaluation electronics.

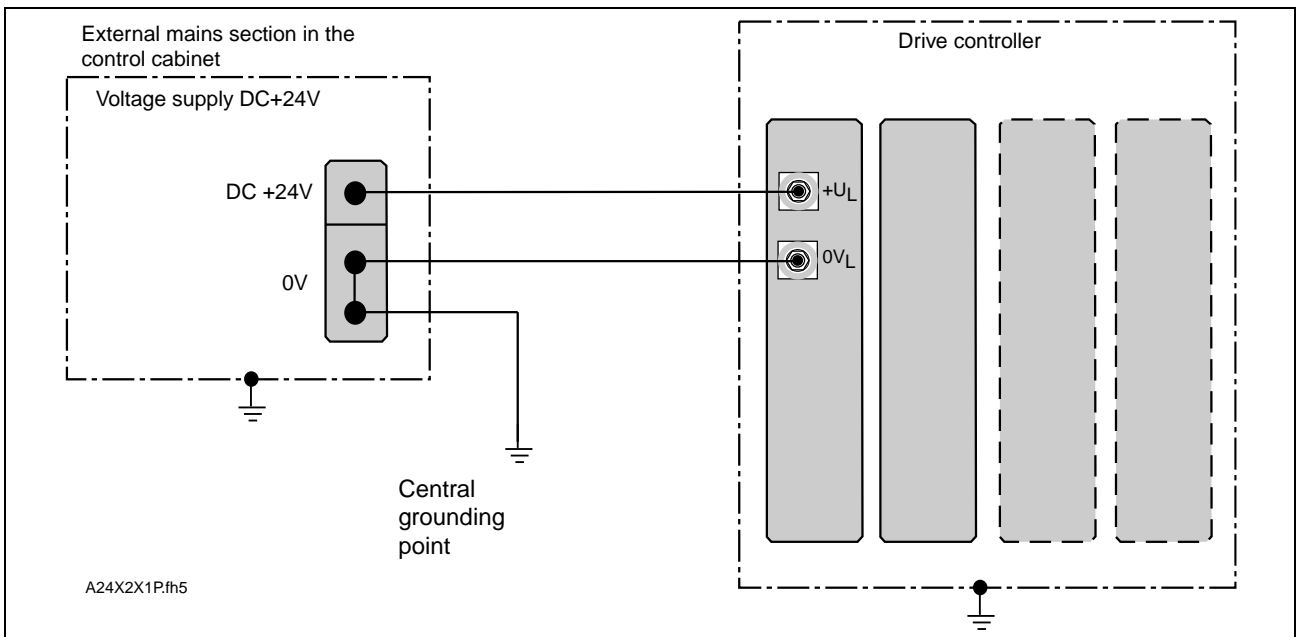

Fig. 4-1: Connecting the DC 24 V voltage source for the optocoupler interface

4.3 Notes on Earth-Fault Monitoring

Due to the ground connections of the above-referenced electric circuits, earth-fault monitoring of INDRAMAT drive and control systems is basically not possible. The grounding of the electric circuit is needed to secure sufficient operating safety and reliability.

An earth-fault monitor only makes sense with relay switches to detect the ground faults which frequently occur there. Electronic equipment does not need earth-fault monitoring and generally does not achieve its intended purpose, namely, increased operating safety.

5 Control Card CLC-D01.1A-FW

5.1 Terminal Diagram CLC-D01.1A-FW

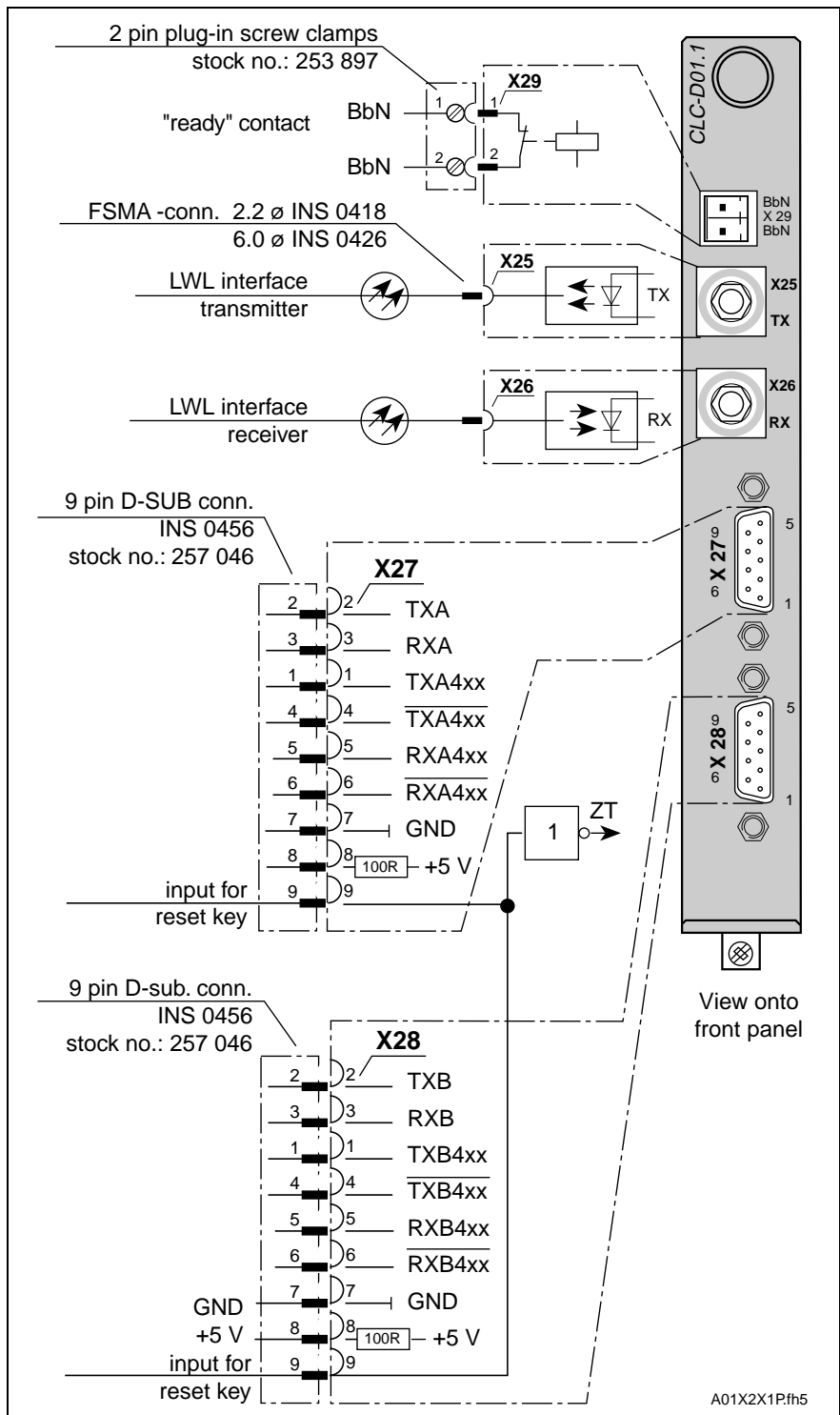

Fig. 5-1: Terminal Diagram CLC-D01.1A-FW

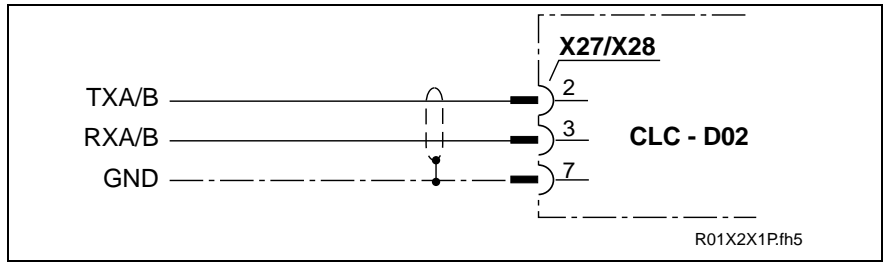

Fig. 5-2: Terminal Diagram RS 232

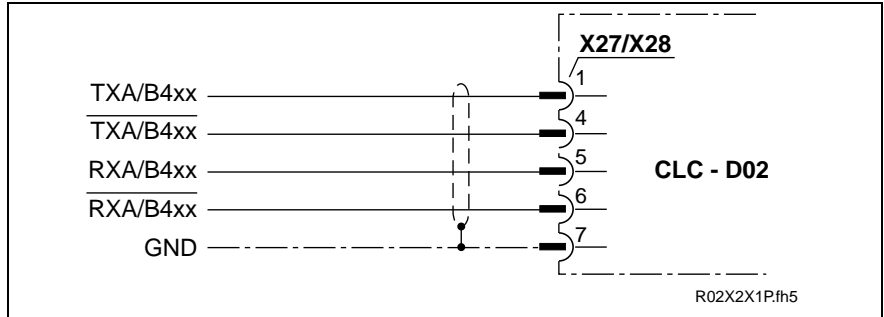

Fig. 5-3: Terminal Diagram RS 422

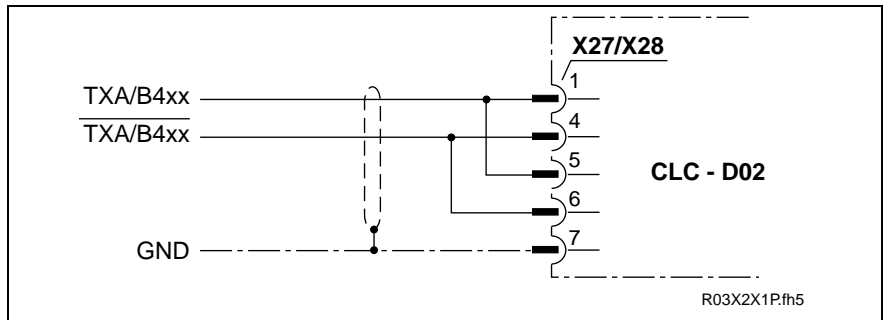

Fig. 5-4: Terminal Diagram RS 485

Parameter	RS 232	RS 422	RS 485
Type	non-symmetric	symmetric	symmetric
Maximum cable length	15m	1200m	1200m
Max. transmission rate	38400 baud	9600 baud	9600 baud
Max. transmitter output voltage	±15 V	±5 V*	±5 V*
Max. receiver input voltage	±25 V	±14 V*	-14 V*
Input sensitivity	±3 V	±200 mV	±200 mV
Input resistance	3...7 kΩ	4 kΩ	12 kΩ
*) Differential signals			

Fig. 5-5: Technical data - RS 232, RS 422, RS 485

BbN contact, X29

Name	Unit	max.
Switching voltage	V	125
Switching current	A	8
Switching power	W	50...220 W (voltage dependent)

Fig. 5-6: Technical data - BbN contact, X29

Technical data - fiber optic cable interface

	Name	Abbreviation	Unit	Wert
Transmitter data Tx	max. transmission power with opt. low-level	P_{SmaxL}	dBm/ μ W	-28.2/1.5
	min. transmission power with opt. high-level	P_{SminH}	dBm/ μ W	-7.5/180
	max. transmission power with opt. high-level	P_{SmaxH}	dBm/ μ W	-3.5/450
	wavelength of transmitter diode: peak wavelength spectral bandwidth	λ_p λ_p	nm nm	640...675 nm (0° C..55° C) - 30 nm (25° C)
Receiver data Rx	max. input power with opt. low-level	P_{EmaxL}	dBm/ μ W	-31.2/0.75
	min. input power with opt. high-level	P_{EminH}	dBm/ μ W	-20/10
	max. input power with opt. high-level	P_{EmaxH}	dBm/ μ W	-5/320
	max. attenuation of transmission path	$P_{SminH} \dots P_{EminH}$	dB	12.5

The transmission power can be set via the relevant software parameter.

Fig. 5-7: Technical data - fiber optic cable interface

Battery There is a 3 voltage button cell on the CLC for RAM back up.

Note: Once the battery is dead, both C and A parameters could be lost. Therefore, back up the parameters!

INDRAMAT stock number: 254 284

Lifespan of battery The battery has a capacity of at least 75% at the time of delivery. Reaching about 10% of total capacity means the battery is empty. The lifespan of the battery depends on how the CLC is operated. The following table offers an approximation:

Ambient temperature	3 shift operation	2 shift operation	1 shift operation	Storage
25° C	4 years	4 years	4 years	3 years
35° C	4 years	3 years	2 years	1.5 years
45° C	3 years	2 years	1.2 years	0.8 years

Fig. 5-8: Battery service lifespan

Notes: The battery is empty at the end of this time and must always be replaced.

Replacing the battery Upon removal of the battery, all parameters remain backed up for at least one minute.

Procedure:

- ⇒ have replacement batteries handy
- ⇒ switch machine off
- ⇒ pull CLC card
- ⇒ pull old battery out
- ⇒ insert new battery **no more than one minute** later

Notes:

6 Control card CLC-D02.1A-FW and CLC-D02.3A-FW

6.1 Terminal Diagram CLC-D02.1A-FW and CLC-D02.3A-FW

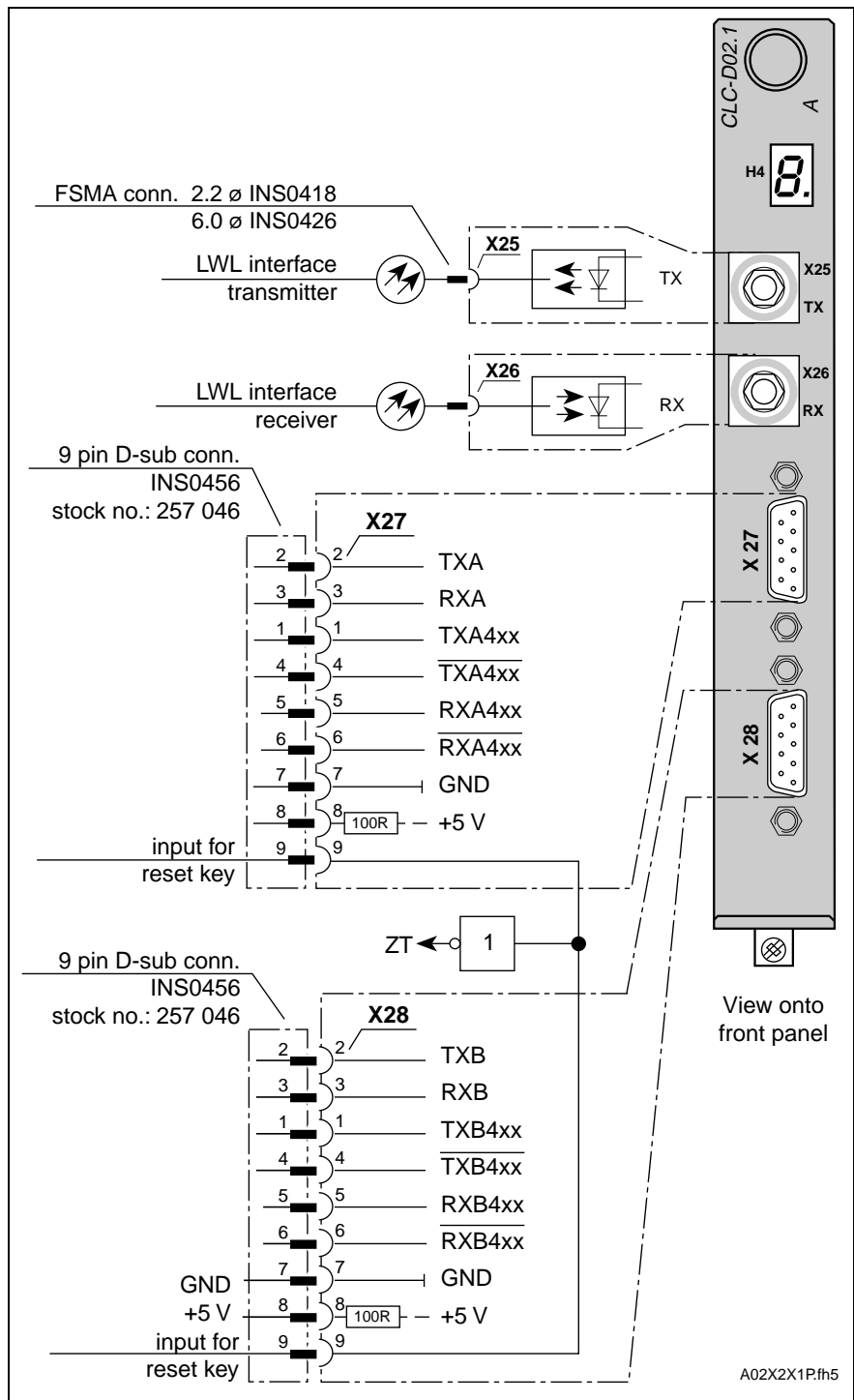

Fig. 6-1: Terminal Diagram CLC-D02.1A-FW and CLC-D02.3A-FW

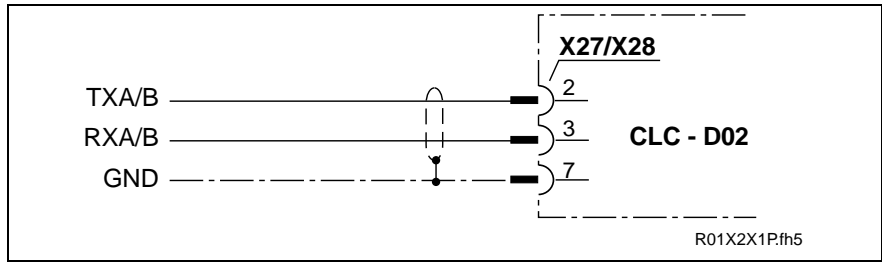

Fig. 6-2: Terminal Diagram RS 232

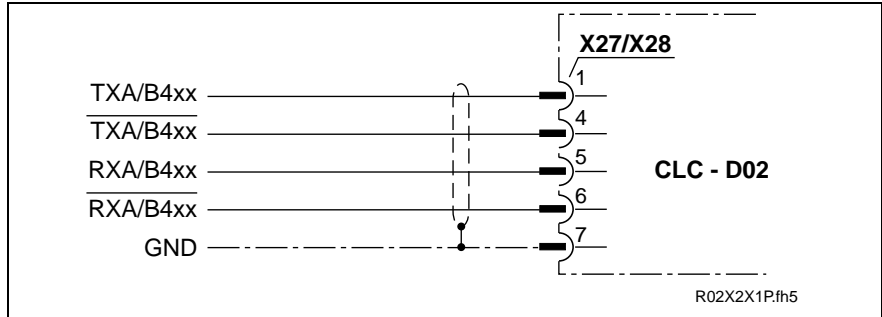

Fig. 6-3: Terminal Diagram RS 422

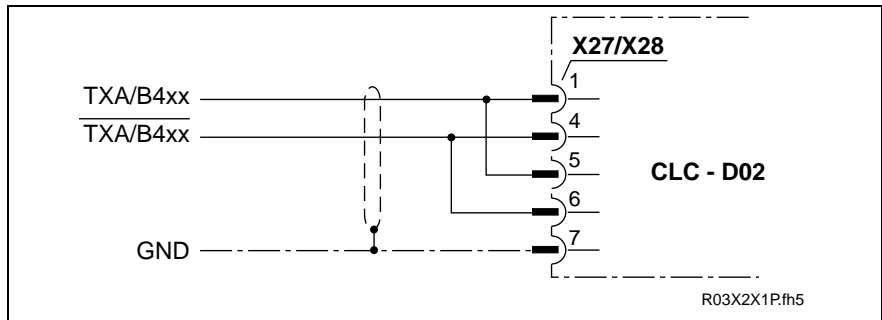

Fig. 6-4: Terminal Diagram RS 485

Parameter	RS 232	RS 422	RS 485
Type	non-symmetric	symmetric	symmetric
Maximum cable length	15m	1200m	1200m
Max. transmission rate	38400 baud	9600 baud	9600 baud
Max. transmitter output voltage	±15 V	±5 V*	±5 V*
Max. receiver input voltage	±25 V	±14 V*	-14 V*
Input sensitivity	±3 V	±200 mV	±200 mV
Input resistance	3...7 kΩ	4 kΩ	12 kΩ
*) Differential signals			

Fig. 6-5: Technical data - RS 232, RS 422, RS 485

Technical data - fiber optic cable interface

	Name	Abbreviation	Unit	Wert
Transmitter data Tx	max. transmission power with opt. low-level	P_{SmaxL}	dBm/ μ W	-28,2/1,5
	min. transmission power with opt. high-level	P_{SminH}	dBm/ μ W	-7.5/180
	max. transmission power with opt. high-level	P_{SmaxH}	dBm/ μ W	-3.5/450
	wavelength of transmitter diode: peak wavelength spectral bandwidth	λ_p λ_p	nm nm	640...675 nm (0° to 55° C) - 30 nm (25° C)
Receiver-data Rx	max. input power for opt. low level	P_{EmaxL}	dBm/ μ W	-31.2/0.75
	min. input power for opt. high level	P_{EminH}	dBm/ μ W	-20/10
	max. input power for opt. high level	P_{EmaxH}	dBm/ μ W	-5/320
	max. attenuation of the transmission path	$P_{SminH} \dots P_{EminH}$	dB	12.5

Transmission output can be set with software parameters..

Fig. 6-6: Technical data - fiber optic cable interface

Battery There is a 3 volt button cell for RAM back-up.

Note: Once the battery is dead, both C and A parameters could be lost. Therefore, back up the parameters!

INDRAMAT stock number: 254 284

Battery lifespan The battery has a capacity of at least 75% at the time of delivery. Reaching about 10% of total capacity means the battery is empty.

The lifespan of the battery depends on how the CLC is operated. The following table offers an approximation:

Ambient temperature	3 shift operations	2 shift operations	1 shift operations	Storage
25° C	4 years	4 years	4 years	3 years
35° C	4 years	3 years	2 years	1,5 years
45° C	3 years	2 years	1,2 years	0,8 years

Fig. 6-7: Battery lifespan

Notes: At the end of this time, the battery is empty and must be replaced.

Battery tauschen Upon removal of the battery, all parameters remain backed up for at least one minute.

Procedure:

- ⇒ have replacement batteries handy
- ⇒ switch machine off
- ⇒ pull CLC card
- ⇒ pull old battery out
- ⇒ insert new battery **no more than one minute** later

Notes:

7 ANALOG interface with Absolute Encoder Emulator DAA01.1

7.1 General Information

Plug-in module DAA01.1 makes it possible to operate the digital intelligent AC servo drive with conventional NC control units via an analog interface. It also contains control inputs and signal outputs for communication with a connected control unit and outputs absolute position feedback values as per SSI standards (synchronous serial interface).

7.2 Terminal Diagram DAA01.1

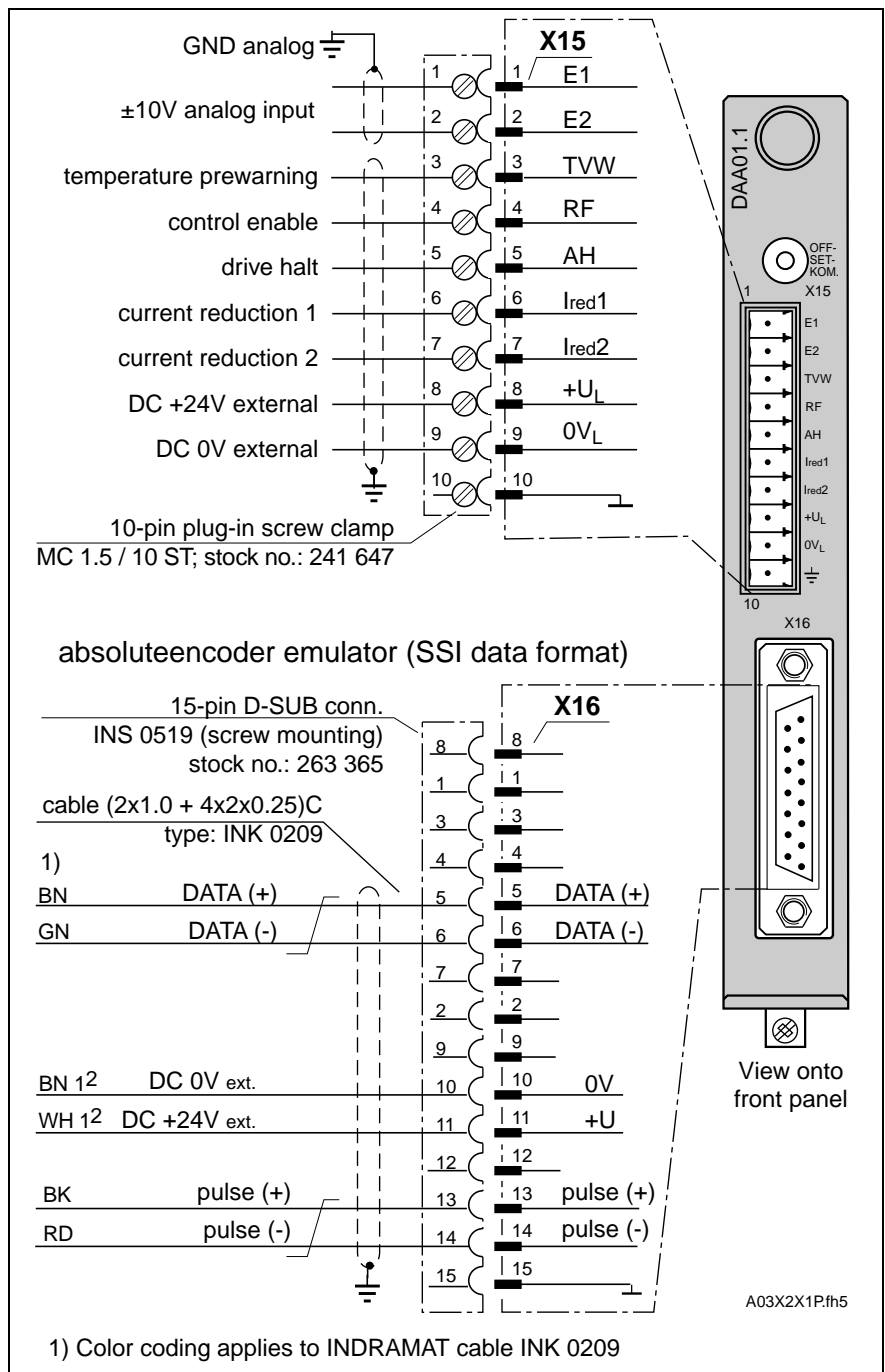

Fig. 7-1: Terminal Diagram - DAA01.1

7.3 Technical Data

Analog interface

Designation		Unit	min.	max.
Input voltage 1)	E1	V	-10	+10
	E2	V	-10	+10
	E1-E2	V		10
Input current	E1	mA	-0.25	+0.25
	E2	mA	-0.5	+0.5

1) The input voltage resolution equals: $20V/2^{16}=0.3\text{ mV}$

Fig. 7-2: Analog command value interface data

Power supply / inputs and outputs

Designation		Unit	min.	type	max.
External power supply+U _L		V	18	24	32
Current consumption- +U _L		mA			100
Inputs RF, AH, I _{red1} , I _{red2}	U _{High}	V	14	24	32
	U _{Low}	V	0	<1	3
Output TVW	I _{Out}	mA			100

Fig. 7-3: Data - power supply and digital inputs and outputs

Differential input analog command value

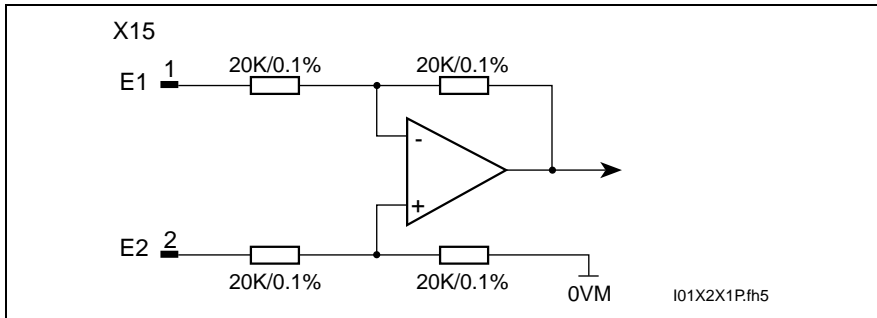

Fig. 7-4: Input circuit for analog interface

Schematic diagram - input/output circuit

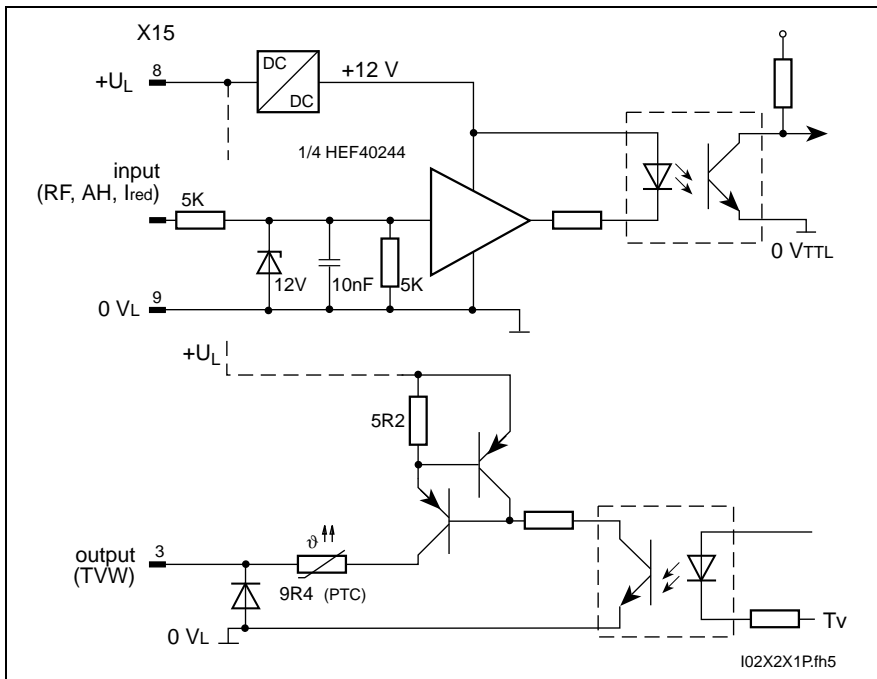

Fig. 7-5: Schematic diagram - input/output circuit

Designation	Unit	min.	type	max.
Power supply +U _{ext}	V	10	24	32
Current consumption- +U _{ext}	mA		100	200
Transmitter				
Output current				
Low level I _{OL}	mA			60
High level I _{OH}	mA			-60
Output voltage V _{D01} with I ₀ =0	V	0		5.25
Differential output voltage				
V _{D01} if I ₀ =0	V	1.5		5.25
V _{D02} if R _L =54Ω	V	1.5		5.0
Receiver				
Differential input voltage				
Low level V _{TL}	V	0.2		
High level V _{TL}	V			0.2
Hysteresis V _{HVS}	mV		50	

Fig. 7-6: Power supply and signal level of absolute encoder emulator

Absolute encoder - output circuit

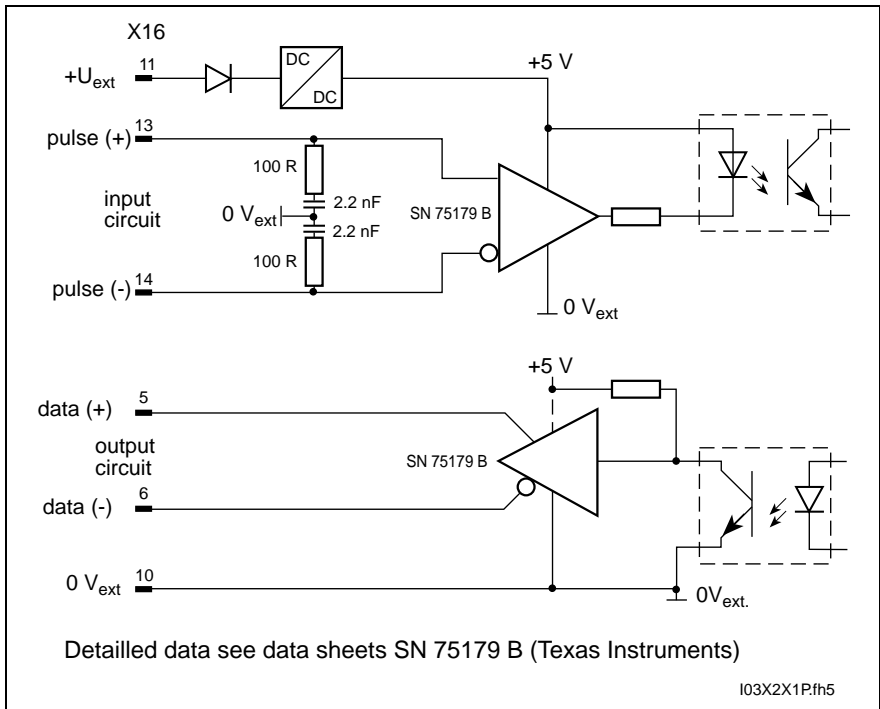

Fig. 7-7: Absolute encoder - output circuit

Standard cable for X16

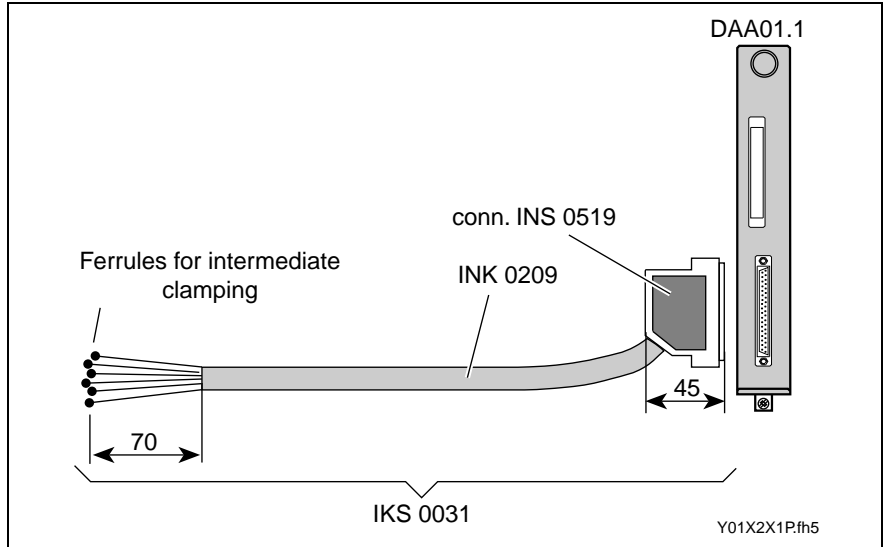

Fig. 7-8: Standard cable for X16

Recommended data transmission pulse frequency

The pulse frequency depends on the cable length.

Cable length in m	Pulse frequency in kHz
< 50	< 400
< 100	< 300
< 200	< 200
< 400	< 100

Fig. 7-9: Cable length and pulse frequency

Actual feedback output in absolute format	Sampling code:	gray code
	Extent of data:	4096 revolutions
	Resolution:	4096 increment / revolution
	Data format:	24 Bit + PFB
	Counting direction:	switchable
	Data transmission:	synchronous, serial
	Input, output circuit:	Driver per EIA RS 422 A
	Least-significant bit:	G0
	Most-significant bit:	G23
	Pulse frequency :	$f_T = 100 \text{ kHz} \dots 1 \text{ MHz}$
	Pulse signal period	$T = 1 \mu\text{s} \dots 10 \mu\text{s}$
	Monoflop time:	$t_m = 15 \mu\text{s} \dots 25 \mu\text{s}$
	Pulse break:	$T_p = 40 \mu\text{s}$
	Delay time (max.):	$t_v = \text{first pulse } 540 \text{ ns, additional } 360 \text{ ns}$
	Power Failure Bit (PFB):	not used and is always logically "0"

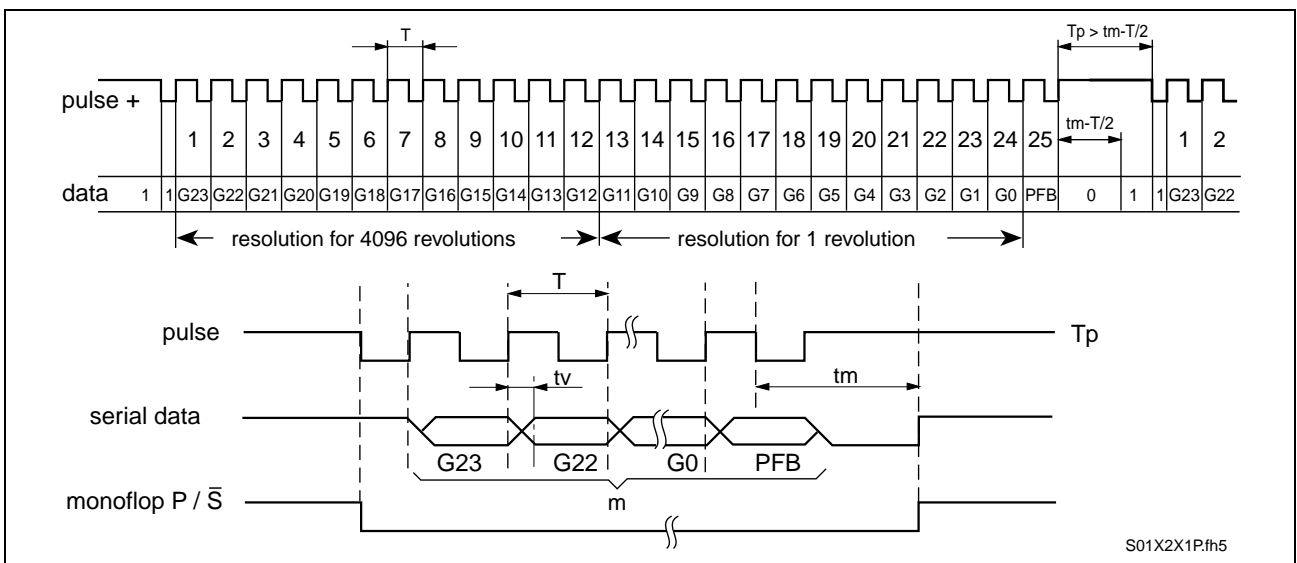

Fig. 7-10: Schematic diagram - signal paths



DANGER

Error in control of motors and moving parts

Bodily injury and property damage caused by unwanted axis motions.

If breaks in the power supply $+U_{ext}$ occur with less than 10 V over a period greater than 100 μs , then encoder information could be incorrect.

⇒ Activate lag distance monitor in control unit!

Actual position feedback output in modulo format	Sampling code:	gray code
	Extent of data:	1 table rotation
	Resolution:	262 144 increments per table rotation
	Data format:	18 Bit
	Counting direction:	switchable
	Data transmission:	synchronous, serial
	Input, output circuit:	Driver per EIA RS 422 A
	Least-significant bit:	G0
	Most-significant bit:	G17
	Pulse frequency :	$f_r = 100 \text{ kHz} \dots 1 \text{ MHz}$
	Pulse signal period	$T = 1 \mu\text{s} \dots 10 \mu\text{s}$
	Monoflop time:	$t_m = 15 \mu\text{s} \dots 25 \mu\text{s}$
	Pulse break:	$T_p = 40 \mu\text{s}$
Delay time (max.):	$t_v = \text{first pulse } 540 \text{ ns, additional } 360 \text{ ns}$	
Stored parallel information:	m	

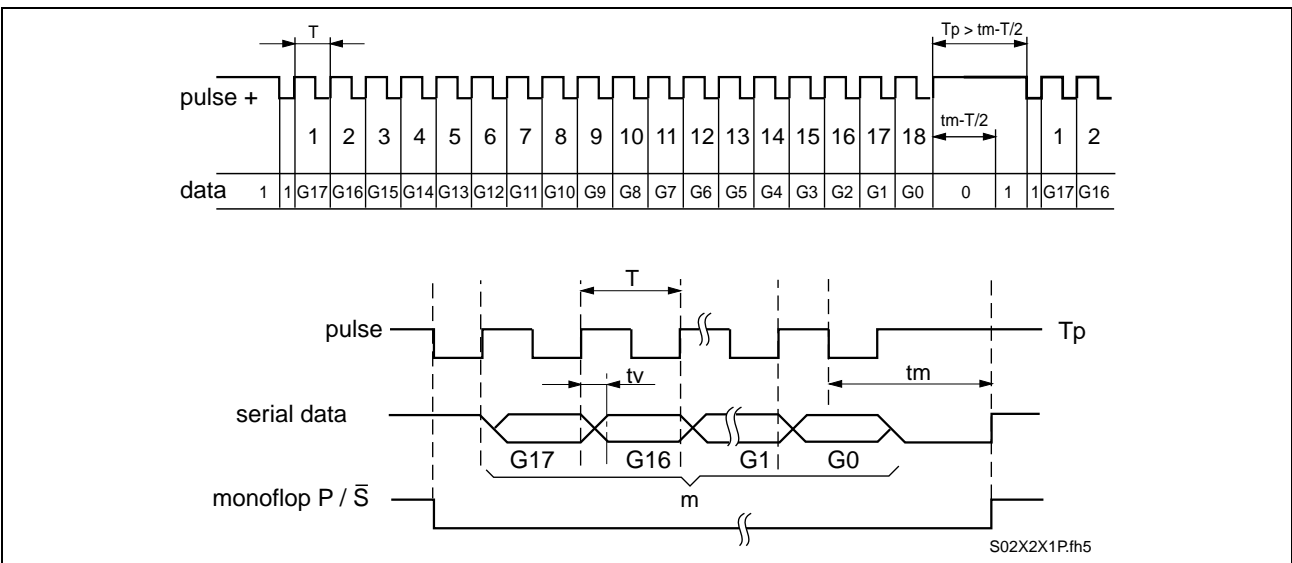

Fig. 7-11: Schematic diagram - signal paths



Error in control of motors and moving parts

Bodily injury and property damage caused by unwanted axis motions.

If breaks in the power supply $+U_{ext}$ occur with less than 10 V over a period greater than 100 μs , then encoder information could be incorrect.

⇒ Activate lag distance monitor in control unit!

Notes:

8 ANALOG interface with Incremental encoder emulator DAE01.1

8.1 General Information

The plug-in module DAE01.1 makes it possible to operate the digital intelligent AC servo drive with conventional NC control units via analog interfaces. It also contains control inputs and signal outputs for communication with a connected NC control unit and generates incremental encoder signals which can be used as position feedback values.

8.2 Terminal Diagram DAE01.1

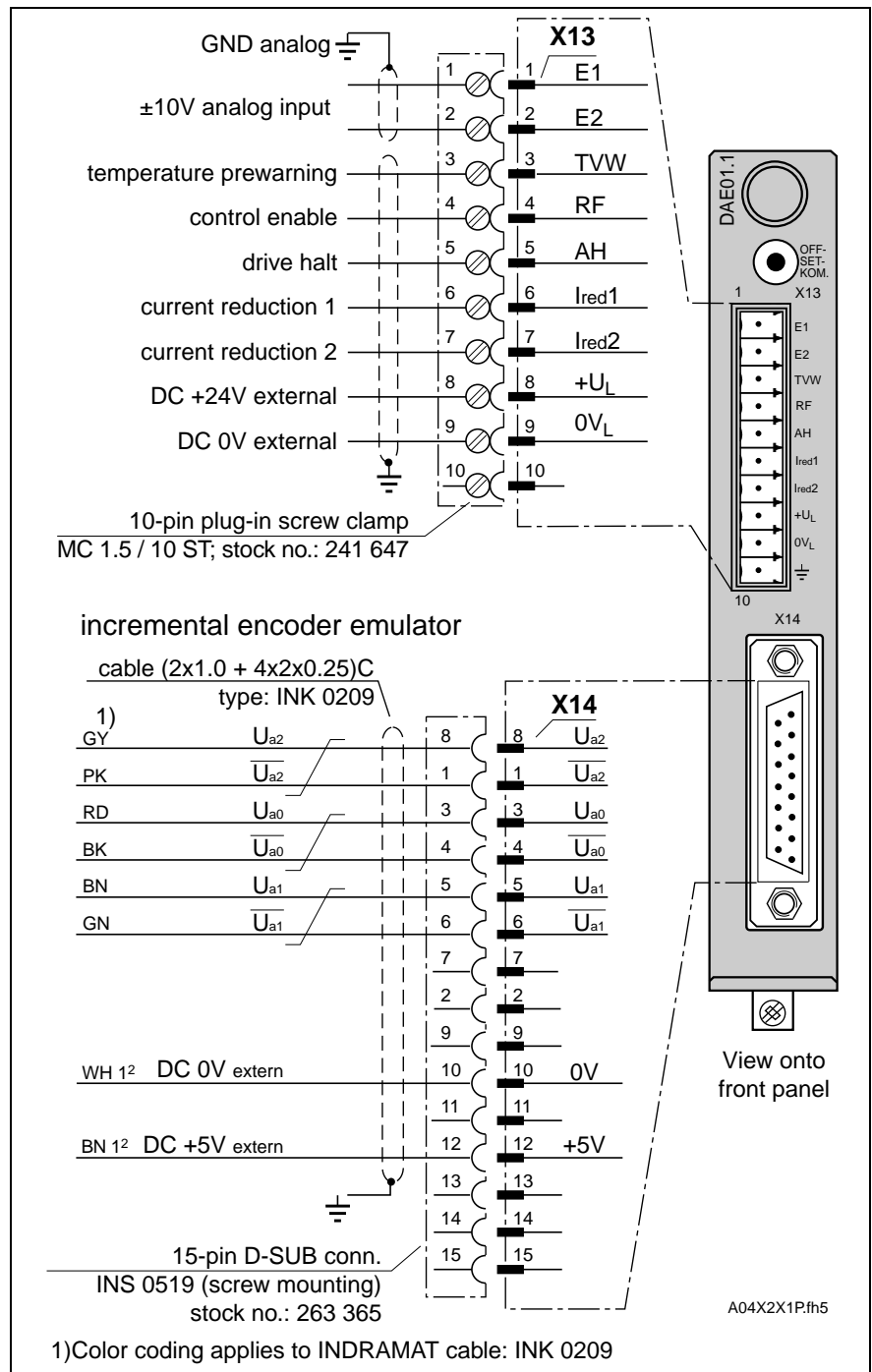

Fig. 8-1: Terminal Diagram - DAE01.1

8.3 Technical Data

Analog interface

Designation		Unit	min.	max.
Input voltage 1)	E1	V	-10	+10
	E2	V	-10	+10
	E1-E2	V		10
Input current	E1	mA	-0,25	+0,25
	E2	mA	-0,5	+0,5

1) The input voltage resolution equals: $20V/2^{16}=0.3\text{ mV}$

Fig. 8-2: Analog command value interface data

Power supply / inputs and outputs

Designation		Unit	min.	type	max.
External power supply+U _L		V	18	24	32
Current consumption- +U _L		mA			100
Inputs RF, AH, I _{red1} , I _{red2}	U _{High}	V	14	24	32
	U _{Low}	V	0	<1	3
OutputTVW	I _{Out}	mA			100

Fig. 8-3: Data - power supply and digital inputs and outputs

Differential input analog command value

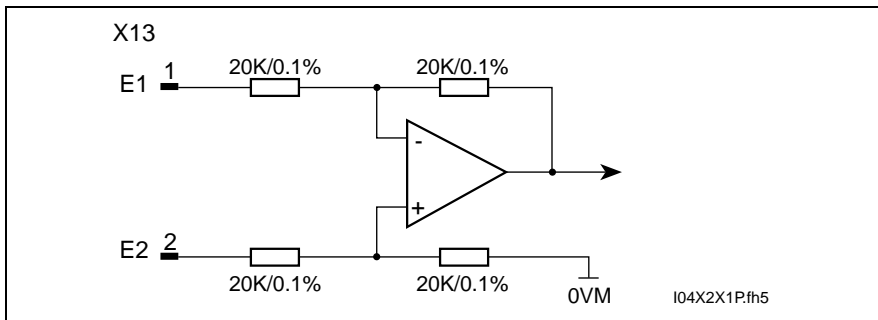

Fig. 8-4: Input circuit to the analog interface

Schematic diagram - input and output circuits

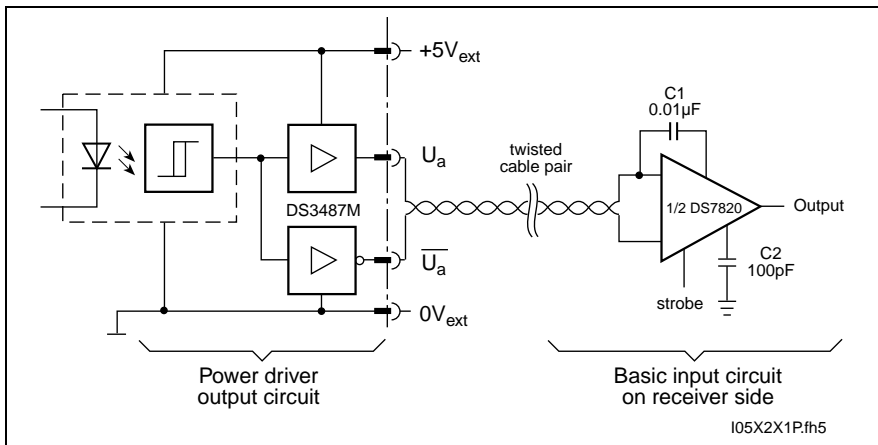

Fig. 8-5: Schematic diagram - input and output circuits

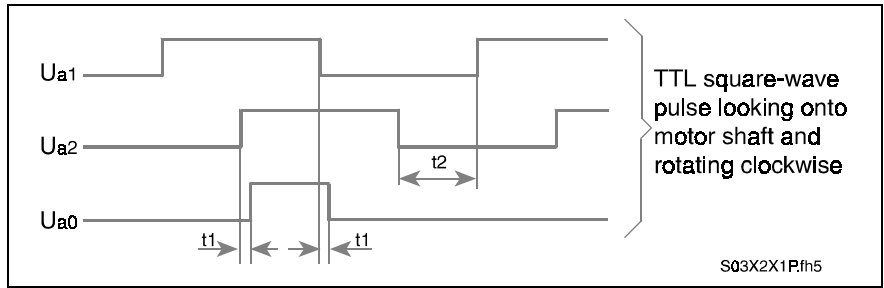

Fig. 8-6: Incremental encoder output signals

Schematic diagram - input and output circuits

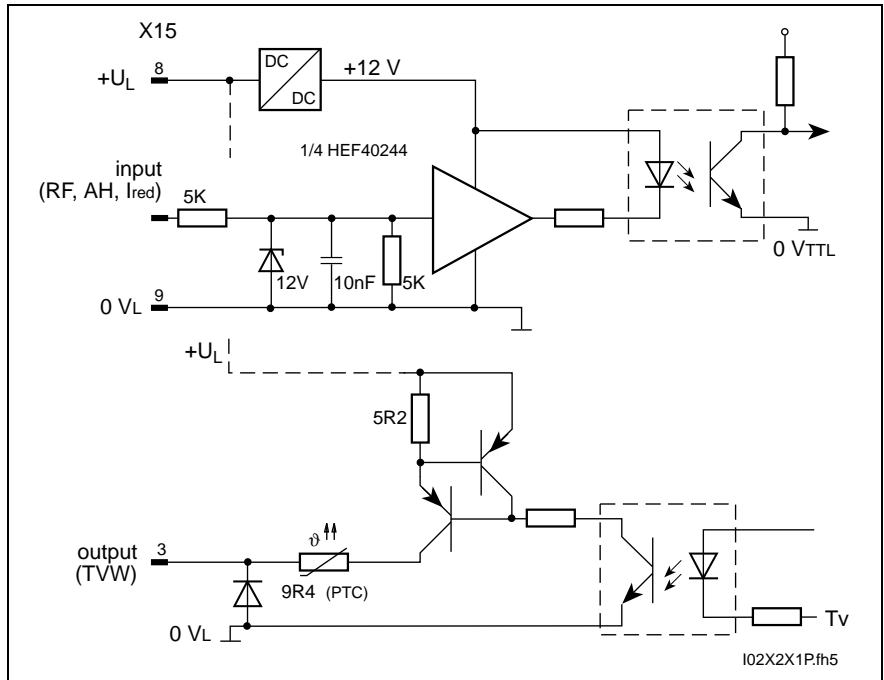

Fig. 8-7: Schematic diagram - input and output circuits

Designation	Unit	min.	type	max.	
Power supply +5V	V	4.75	5	5.25	
Current consumption- +5V	mA			175	
Signal level at 40 mA U_{a0}, U_{a1}, U_{a2}	U_{high}	V	1.8	3.3	5.25
	U_{low}	V		0.22	0.5
Output current	mA			40	
Output frequency	kHz			504	
Rise and fall time	ns			100	
Reference point delay t1	ns	0	15	30	
Edge distance t2	ns	400			

Fig. 8-8: Power supply and signal level of the incremental encoder emulators

9 ARCNET Coupler Card DAK01.1A

9.1 Connecting an ARCNET Coupler Card DAK01.1A

The "ARCNET Coupler Card" is a plug-in card for the CLC-D 2 control card and creates an interface to an ARCNET bus system.

The node number can be selected with a switch on the front plate.

The green LED on the front plate displays that the ARCNET interface has been initialized and connected to the ARCNET bus.

Front plate DAK01.1A

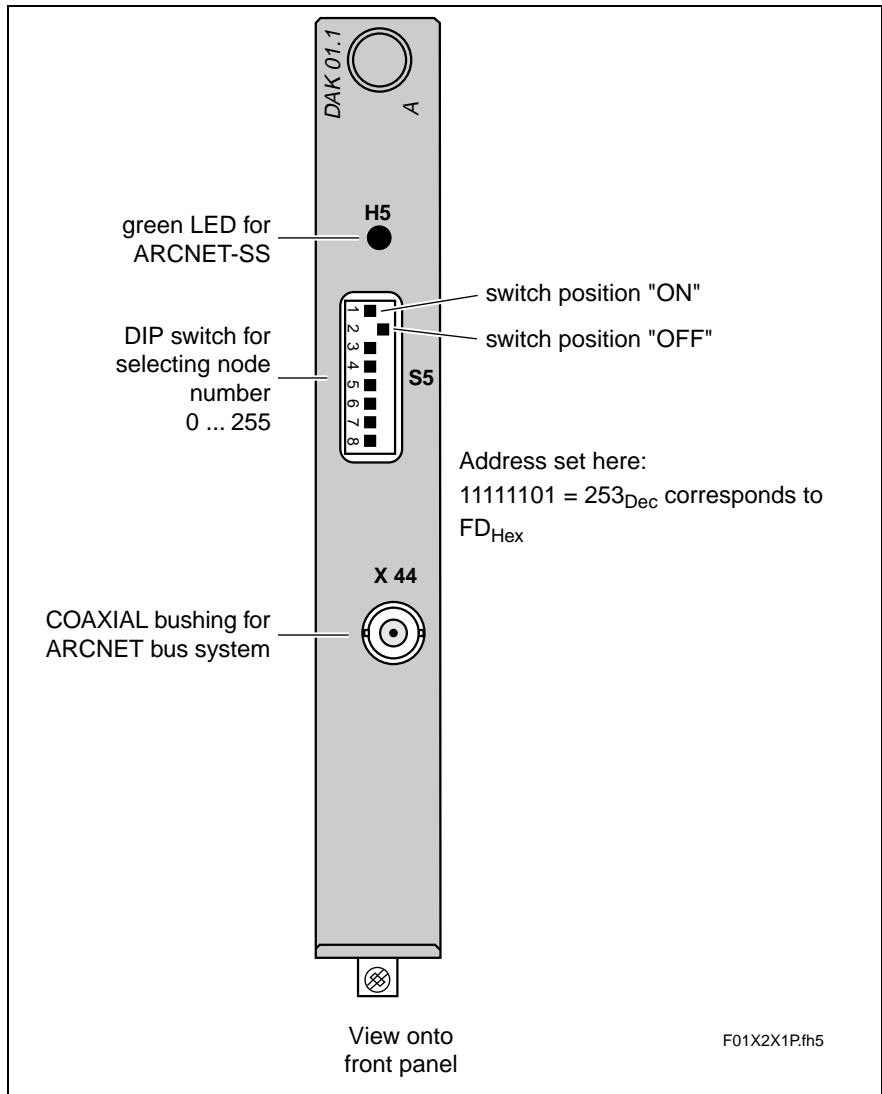

Fig. 9-1: Front plate DAK01.1A

Schematic diagram of an ARCNET bus system

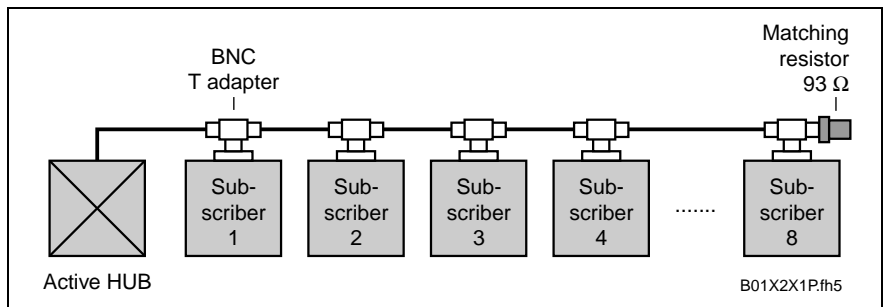

Fig. 9-2: Schematic diagram of an ARCNET bus system

Transmission media, bus connection and bus termination

The network must be constructed with a coaxial cable type RG-62 or RG-71 with an impedance of 93 Ω.

The final ARCNET bus subscriber must be terminated with a resistance of 93 Ω.

Each network subscriber must be connected into the bus segment via a T-BNC adapter.

Node number (subscriber number)

The node number is needed to clearly identify a bus subscriber. This node number must be set within a range of 0 to 255 once the network is started up. Any change in the node number does not become effective until the CLC-D has been switched off and then on once.

Bus connection - DAK

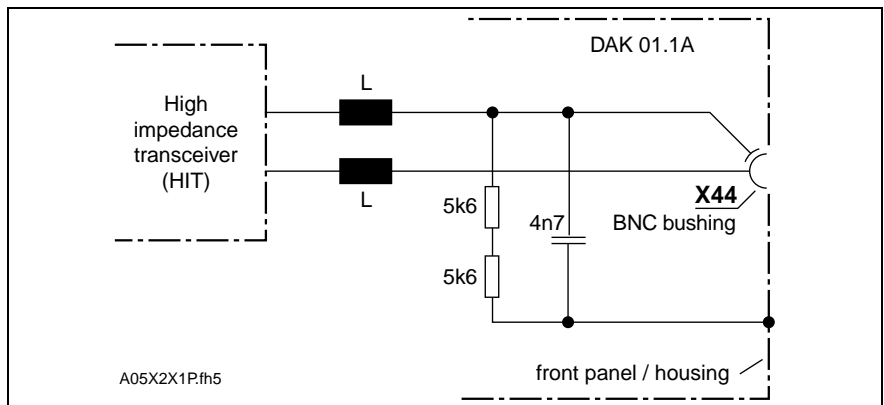

Fig. 9-3: Bus connection - DAK

10 INTERBUS-S interface module DBS02.1-FW

10.1 General Information

Operating modes	The module DBS02.1-FW makes a connection with digital drive controllers of the DIAX02 drive family possible in the operating modes <ul style="list-style-type: none">• speed default as per DRIVECOM Profile 21• referencing as per DRIVECOM Profile 22
Bus network subscriber	The module DBS02.1-FW is a bus network subscriber as defined by the INTERBUS-S. Within one INTERBUS-S bus network installation it is possible to combine this module with any other INTERBUS-S interface module of any other manufacturer, if the module meets the specifications as defined by the INTERBUS-S certificate. Up to 256 bus network subscribers can be combined in one bus network.
Galvanic isolation	The bus network input and output of the INTERBUS-S interface module DBS02.1-FW are galvanically isolated. This achieves the greatest resistance to interference within the network.
LEDs for the INTERBUS-S	There are 8 diagnostic LEDs on the front to quickly check the functioning of the DBS02.1 module. This diagnostics function of the INTERBUS-S ring meets INTERBUS-S standards.

Note: For further details on the functions, please see the relevant Function Description documentation.

10.2 Terminal Diagram

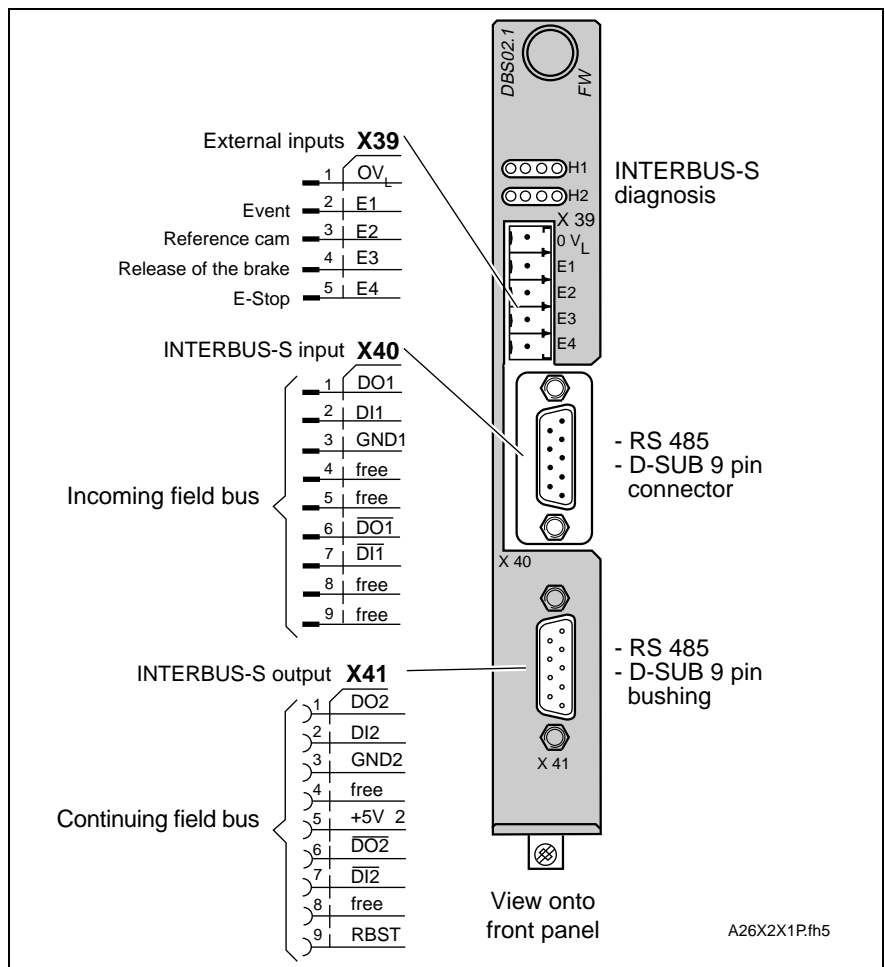

Fig. 10-1: Terminal Diagram

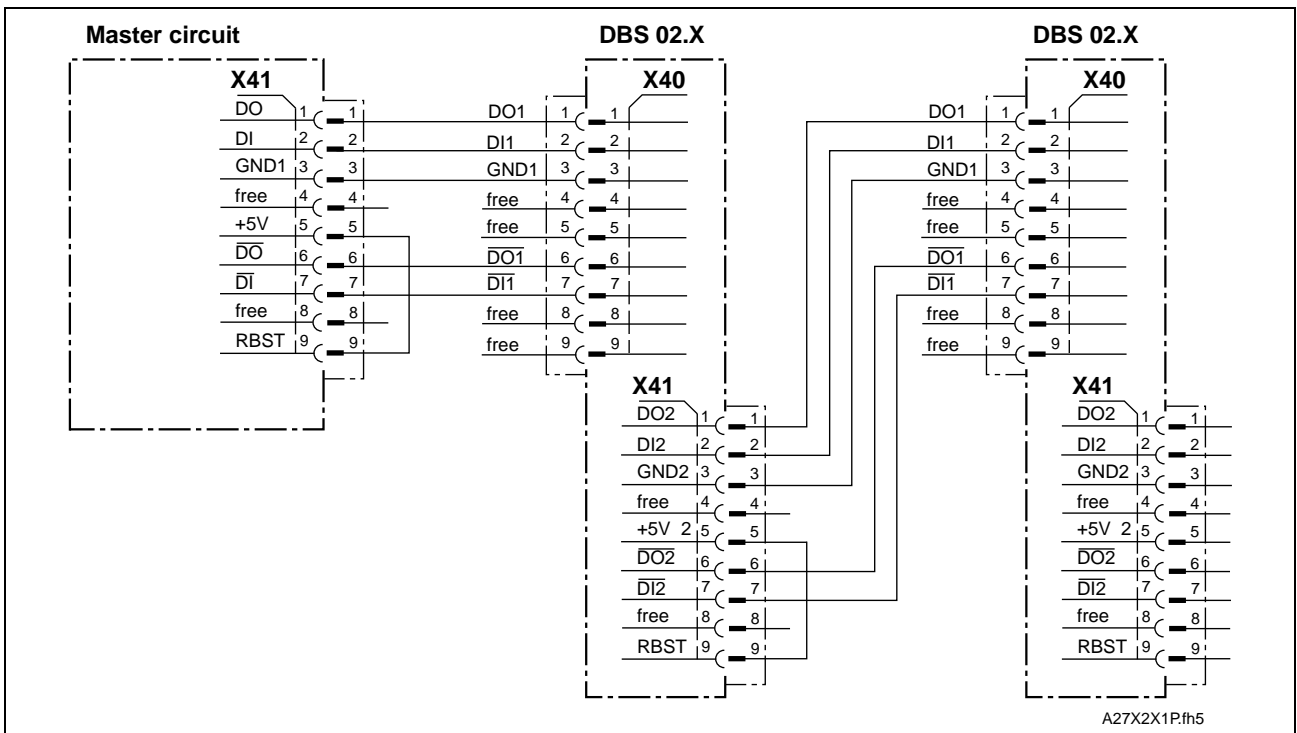

Fig. 10-2: Master interface connection with two bus network subscribers

10.3 Technical Data

INTERBUS-S

Incoming interface

INTERBUS - S standard interface in accordance with DIN E 19258 for bus network subscribers via a D-subminiature 9-pin connector. The interface is completely galvanically isolated. There is a duplex interface connection in it based on an RS 485 for coupling with the previous participant in the INTERBUS - S ring.

Outgoing interface

INTERBUS - S standard interface in accordance with DIN E 19258 for bus network subscribers via a D-subminiature 9-pin bushing. This interface is also completely galvanically isolated. There is a duplex interface connection in it based on an RS 485 for coupling with the following participant. There is also a strobe signal to be able to detect a continuing INTERBUS-S.

External Inputs

Module DBS02.1 has four hardware inputs (+24V).

X39	Designation	Input voltage for high	Input voltage for low
1	0V _L	reference potential 0V	reference potential 0V
2	E1	+16 V... +32 V	-0.5 V ... +8 V
3	E2	+16 V... +32 V	-0.5 V ... +8 V
4	E3	+16 V... +32 V	-0.5 V ... +8 V
5	E4	+16 V... +32 V	-0.5 V ... +8 V

Fig. 10-3: Signal assignment X39 external inputs

Notes

11 INTERBUS-S - interface module DBS02.2-FW

11.1 General Information

Plug-in module construction	<p>The module DBS02.2-FW can only be operated together with positioning module DLC02.1. The INTERBUS-S - interface module DBS02.2-FW is inserted into the DLC02.1. Once screwed together with three bolts, the DBS02.2 and DLC02.1 create one unit.</p> <p>Module DBS02.2-FW together with the positioning module DLC02.1-FW can be operated in different modes.</p>
Operating modes	<p>The mode determines the function in which the module operates.</p> <p>The main mode for module DBS02.2 is positioning targeting in terms of DRIVECOM - standard Profile 22. In addition to this mode, the module also supports operation of the DLC02.1-FW with those functions described in the documentation (DOK no. 109-0852-4102). The conventional I/O level, in this case, is either completely or partially replaced by the INTERBUS - S circuit.</p>
Bus network subscriber	<p>The module DBS02.2-FW represents a bus network subscriber in terms of the INTERBUS-S definition. Within an INTERBUS-S bus network installation it is possible to combine this module with any other INTERBUS-S interface module from any other manufacturer, if the module meets the requirements set forth in the INTERBUS-S certificate. Up to 256 bus network subscribers can be interconnected in one bus network installation.</p>
Galvanic isolation	<p>The INTERBUS-S interface module DBS02.2-FW has galvanically isolated bus network inputs and outputs. This achieves the greatest resistance to interference in the bus network.</p>
LEDs for the INTERBUS-S	<p>There are 8 diagnostic LEDs on the front to quickly check the functioning of the DBS02.1 module. This diagnostics function of the INTERBUS-S ring meets INTERBUS-S standards.</p>

For further details on the functions, please see the Function Description documentation.

Note: Please note, when disassembling or removing a plug-in module from the drive controller that DBS02.2-FW is connected with DLC02.1-FW.

11.2 Terminal Diagram

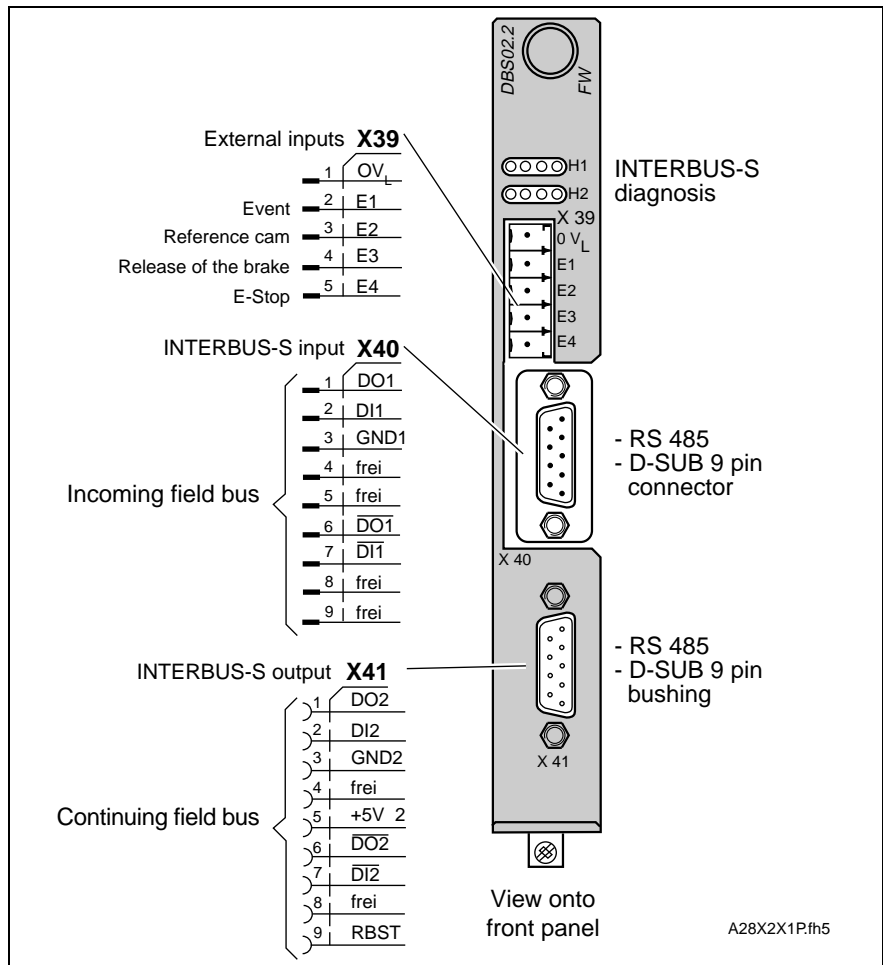

Fig. 11-1: Terminal Diagram

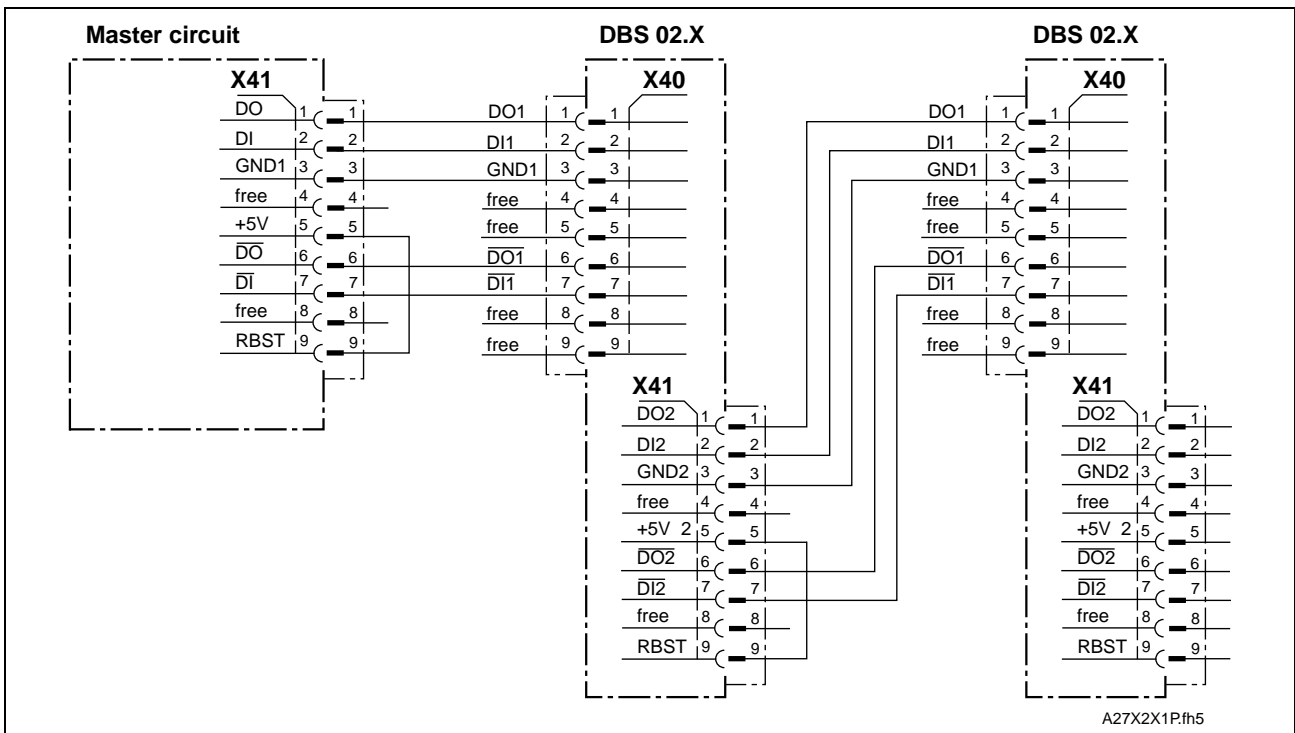

Fig. 11-2: Master interface connection with two bus network subscribers

11.3 Technical Data

INTERBUS-S

Incoming interface

INTERBUS - S standard interface in accordance with DIN E 19258 for bus network subscribers via a D-subminiature 9-pin connector. The interface is completely galvanically isolated. There is a duplex interface connection in it based on an RS 485 for coupling with the previous participant in the INTERBUS - S ring.

Outgoing interface

INTERBUS - S standard interface in accordance with DIN E 19258 for bus network subscribers via a D-subminiature 9-pin bushing. This interface is also completely galvanically isolated. There is a duplex interface connection in it based on an RS 485 for coupling with the following participant. There is also a strobe signal to be able to detect a continuing INTERBUS-S.

External inputs

Module DBS02.2 has four hardware inputs (+24V) which can only be used in conjunction with a DLC.

X39	Designation	Input voltage for high	Input voltage for low
1	0V _L	reference potential 0V	reference potential 0V
2	E1	+16 V... +32 V	-0.5 V ... +8 V
3	E2	+16 V... +32 V	-0.5 V ... +8 V
4	E3	+16 V... +32 V	-0.5 V ... +8 V
5	E4	+16 V... +32 V	-0.5 V ... +8 V

Fig. 11-3: Signal assignment to X39 of the external inputs

Notes

12 INTERBUS-S Slave Module DBS03.1-FW

12.1 General Information

The INTERBUS-S slave module DBS03.1-FW makes it possible to integrate control module CLC-D into an INTERBUS-S system.

The INTERBUS-S interface of module DBS03.1-FW is constructed in terms of a bus network interface and corresponds to the standards set forth in the INTERBUS-S certificate.

Module DBS03.1-FW is designed as a plug-in module to be inserted directly into the control module. Once screwed together with three bolts, it creates one unit with the CLC-D.

Note: Additional modules can be inserted into the DBS03.1-FW. This is important when disassembling and removing!

12.2 Terminal Diagram

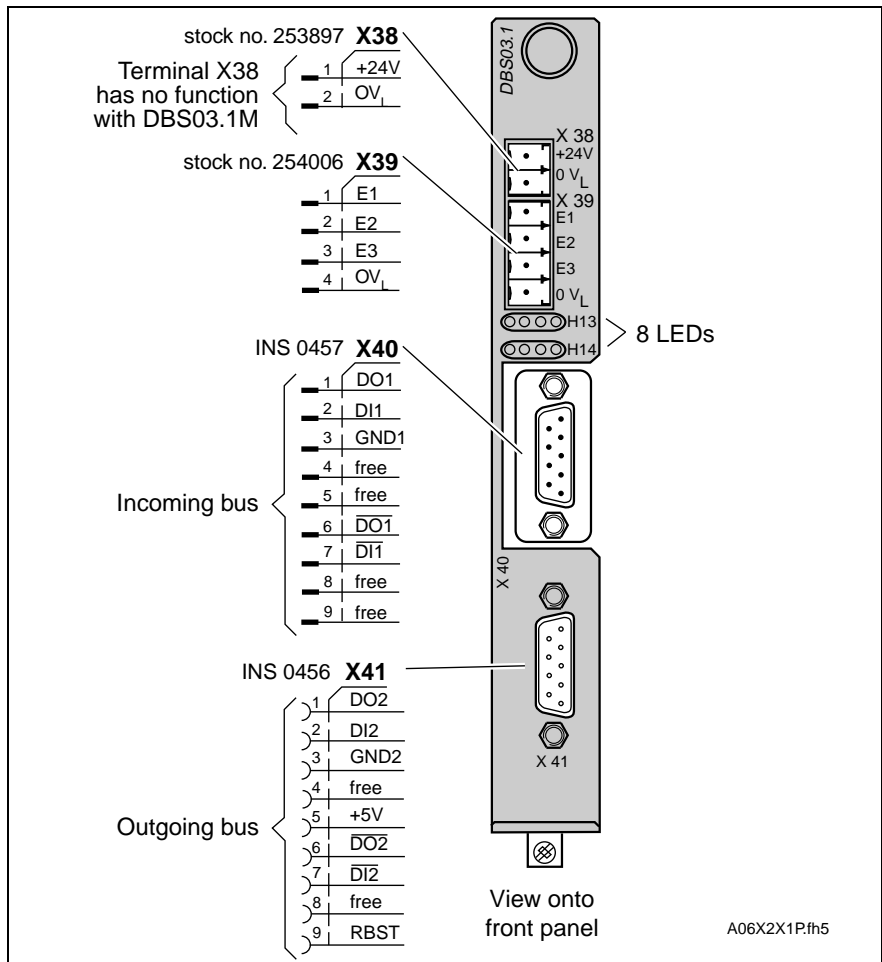

Fig. 12-1: Terminal Diagram

12.3 Technical Data

INTERBUS-S

Incoming interface

INTERBUS - S standard interface in accordance with DIN E 19258 for bus network subscribers via a D-subminiature 9-pin connector. The interface is completely galvanically isolated. There is a duplex interface connection in it based on an RS 485 for coupling with the previous participant in the INTERBUS-S ring.

Outgoing interface

INTERBUS-S standard interface in accordance with DIN E 19258 for bus network subscribers via a D-subminiature 9-pin bushing. This interface is also completely galvanically isolated. There is a duplex interface connection in it based on an RS 485 for coupling with the following participant. There is also a strobe signal for the detection of a continuing INTERBUS-S.

External inputs

Module DBS03.1-FW has three hardware inputs (+24V) which can only be used in conjunction with a CLC-D if supported by the relevant firmware. The signal states at these inputs are transmitted, regardless of INTERBUS-S status (on/off) to the CLC-D but can also be queried by the INTERBUS -S master via the PD or PCP channel.

X3	Designation	Input voltage for high	Input voltage for low
1	E1	+16 V... +32 V	-0.5 V ... +8 V
2	E2	+16 V... +32 V	-0.5 V ... +8 V
3	E3	+16 V... +32 V	-0.5 V ... +8 V
4	0V _L	reference potential 0V	reference potential 0V

Fig. 12-2: Signal assignment X3 external inputs

Note: Module DBS03.1-FW has no INTERBUS-S repeater function maintained by an external power supply if the DBS03.1-FW is decoupled from the internal supply. Therefore, do not wire up the X38 connector.

13 Input / output interface DEA04.1, DEA05.1, DEA06.1

13.1 General Information

These plug-in modules have 15 inputs and 16 outputs via which the drive can exchange binary signals with a PLC.

The difference of the three types specified is the address.

To avoid confusion during installation, the D-subminiature plug-in connectors are differently labelled.

13.2 Terminal Diagram

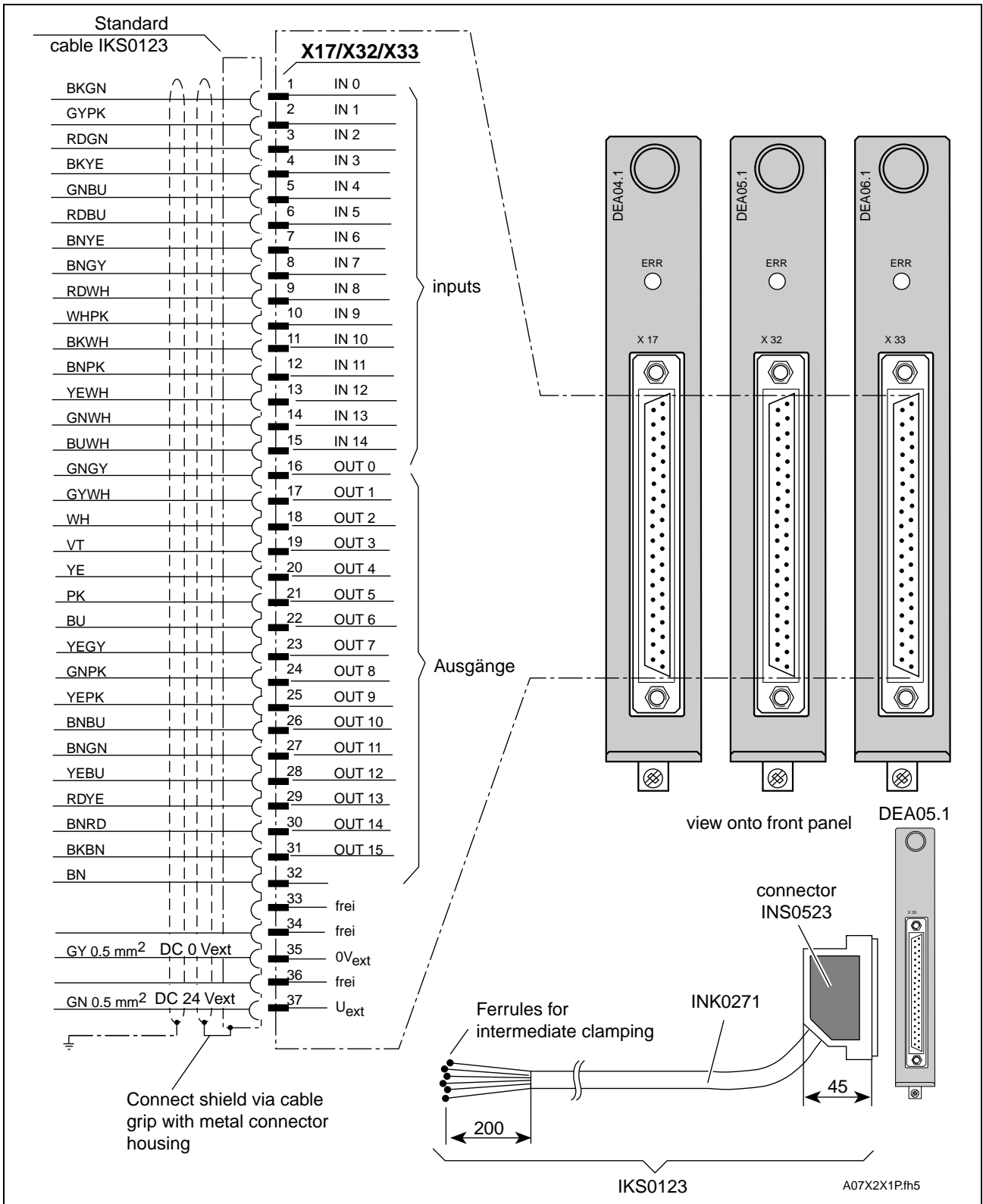

Fig. 13-1: Terminal Diagram DEA04.1, DEA05.1, DEA06.1

13.3 Technical Data - DEA04.1, DEA05.1, DEA06.1

Designation	Unit	min.	type	max.	
Power supply	+U _{ext}	V	18	24	32
Current consumption	I _{ext}	A	0.15	0.2 ¹⁾	2.2 ²⁾
Inputs X17/1...15	+U _{High}	V	14	24	32
	+U _{Low}	V	0	<1	3
Outputs X17/16...31	+U _{high}	V	U _{ext} -2	U _{ext} -1	U _{ext}
	+U _{low}	V	0	1,6	2
	I _L	mA	0	-	80 ³⁾

1) Current consumption of 0.2 A without loading outputs at 24 V
 2) Current consumption of 2.2 A, loading all outputs with 80 mA each
 3) The lamp control necessitates that the making current is limited by means of resistance, e.g., 100 R, to 250 mA as otherwise the overcurrent monitor is actuated and the output locked.

Fig. 13-2: Technical data - DEA04.1, DEA05.1, DEA06.1

Schematic diagram - digital input and output circuits

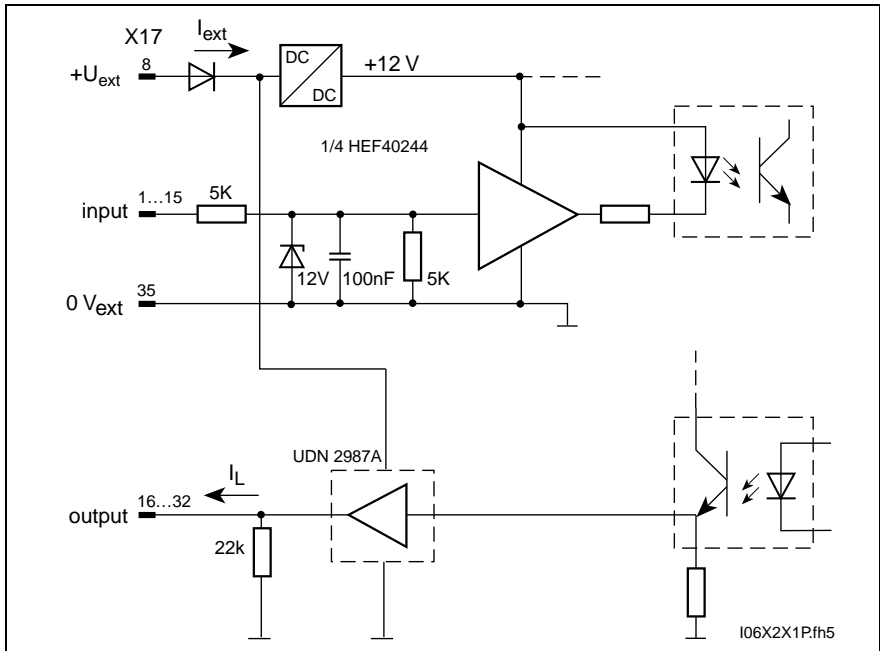

Fig. 13-3: Schematic diagram - digital input and output circuits

Recommended load inductance circuit

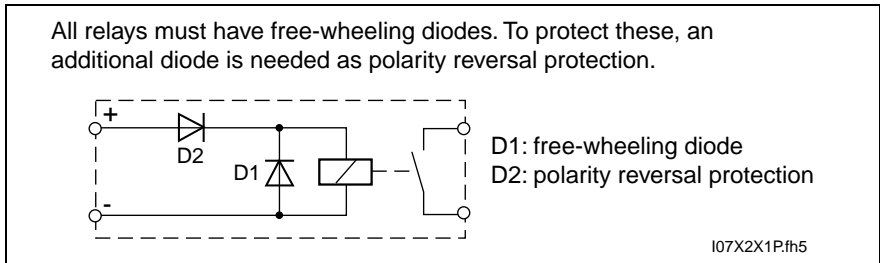

Fig. 13-4: Recommended load inductance circuit

Notes: If driver UND 2987 A has switched off one or more outputs due to overload, then the error state will be displayed by the LED which has been switched on.

Notes:

14 Input / output interface DEA04.2, DEA05.2, DEA06.2

14.1 General Information

These plug-in modules have 15 inputs and 16 outputs via which the drive can exchange binary signals with a PLC.

The difference between the three types is the address.

To avoid confusion during installation, the D-subminiature plug-in connectors are differently labelled.

14.2 Terminal Diagram

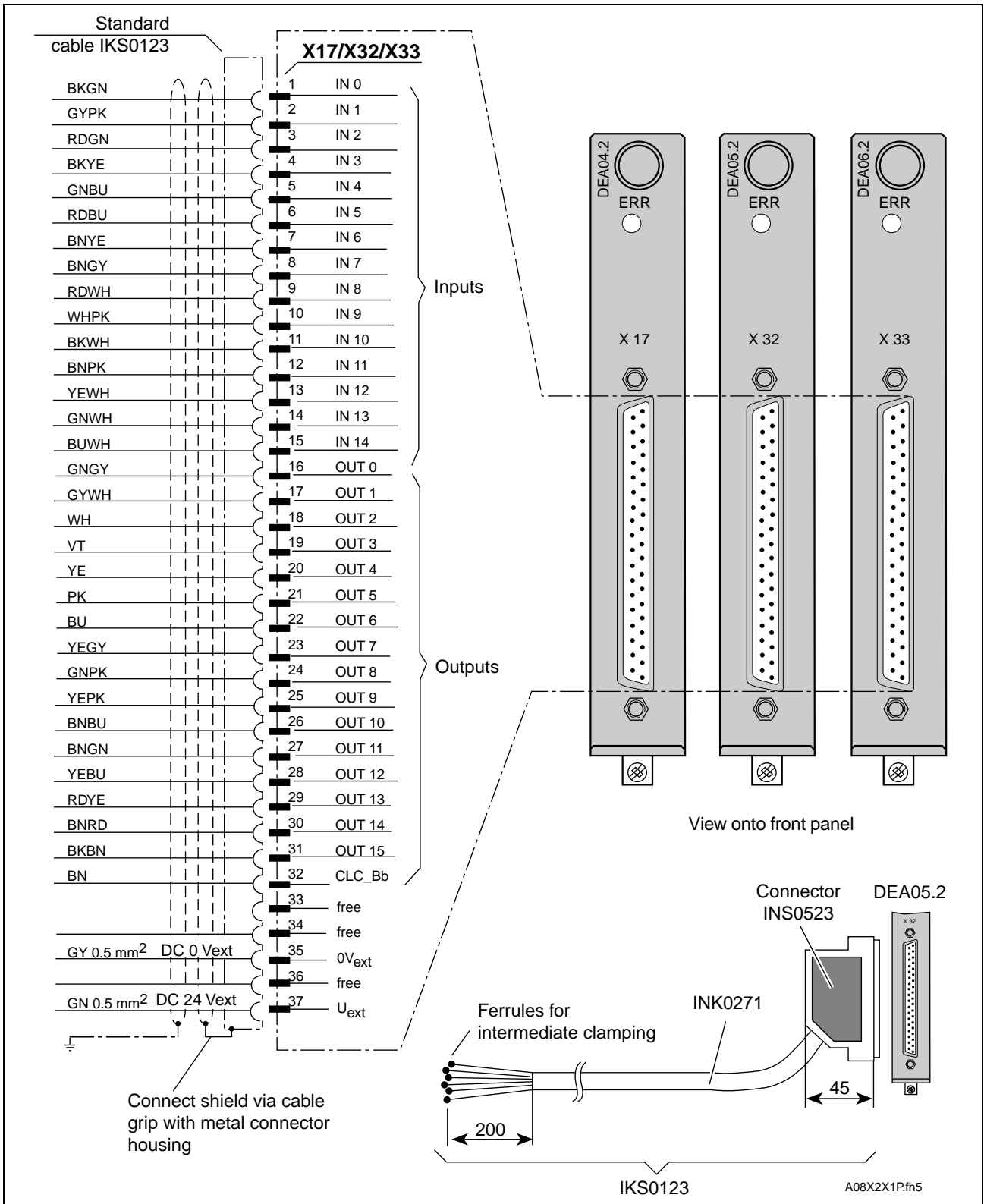

Fig. 14-1: Terminal Diagram DEA04.2, DEA05.2, DEA06.2

14.3 Technical Data - DEA04.2, DEA05.2, DEA06.2

Designation	Unit	min.	type	max.	
Power supply	+U _{ext}	V	18	24	32
Current consumption	I _{ext}	A	0,15	0,2 ¹⁾	2,2 ²⁾
Inputs X17/1...15	+U _{High}	V	14	24	32
	+U _{Low}	V	0	<1	3
Outputs X17/16...31	+U _{high}	V	U _{ext} -2	U _{ext} -1	U _{ext}
	+U _{low}	V	0	1,6	2
	I _L	mA	0	-	80 ³⁾

1) Current consumption of 0.2 A without loading outputs at 24 V
 2) Current consumption of 2.2 A, loading all outputs with 80 mA each
 3) The lamp control necessitates that the making current is limited by means of resistance, e.g., 100 R, to 250 mA as otherwise the overcurrent monitor is actuated and the output locked.

Fig. 14-2: Technical data - DEA04.2, DEA05.2, DEA06.2

Schematic diagram - digital input and output circuits

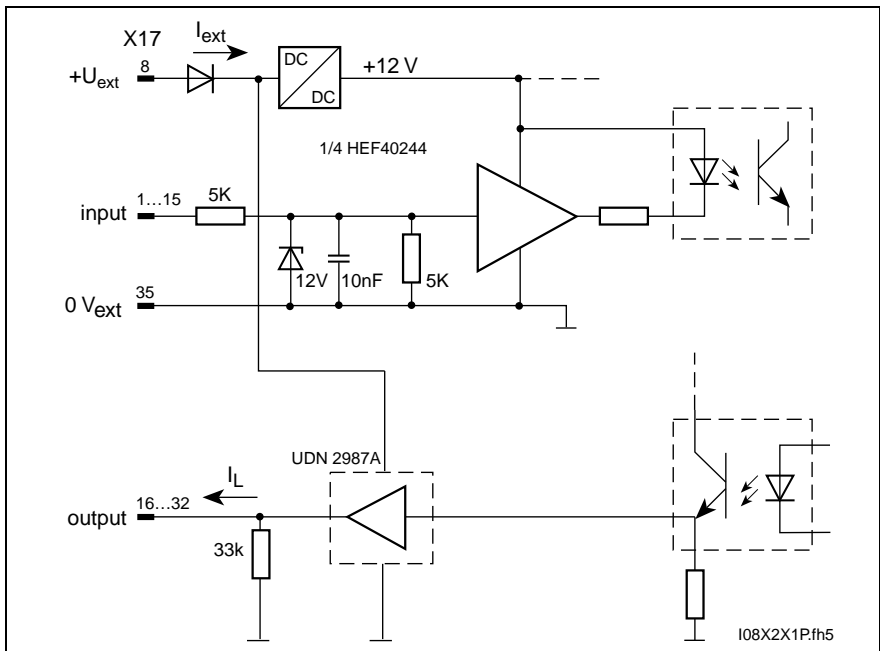

Fig. 14-3: Schematic diagram - digital input and output circuits

Recommended load inductance circuit

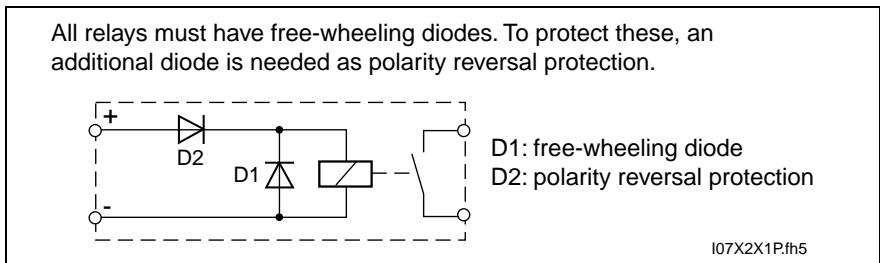

Fig. 14-4: Recommended load inductance circuit

Note: If driver UND 2987 A has switched off one or more outputs due to overload, then the error state will be displayed by the LED which has been switched on.

Output CLC_Bb Output CLC_Bb is set to high with each edge change of output OUT15. Output CLC_Bb remains at high for 100ms. If the state of output OUT15 does not change during this time, then output CLC_Bb goes back to low. If the state of the output OUT15 is altered during this 100 ms period, then output CLC_Bb is retriggered and remains in the high state.

Retrigger time: 100 ms

Note: If output CLC_Bb is used, then output OUT15 can no longer be used as output OUT15 is used to retrigger output CLC_Bb.

Application:
Output CLC_Bb can be used as a kind of "Watchdog".

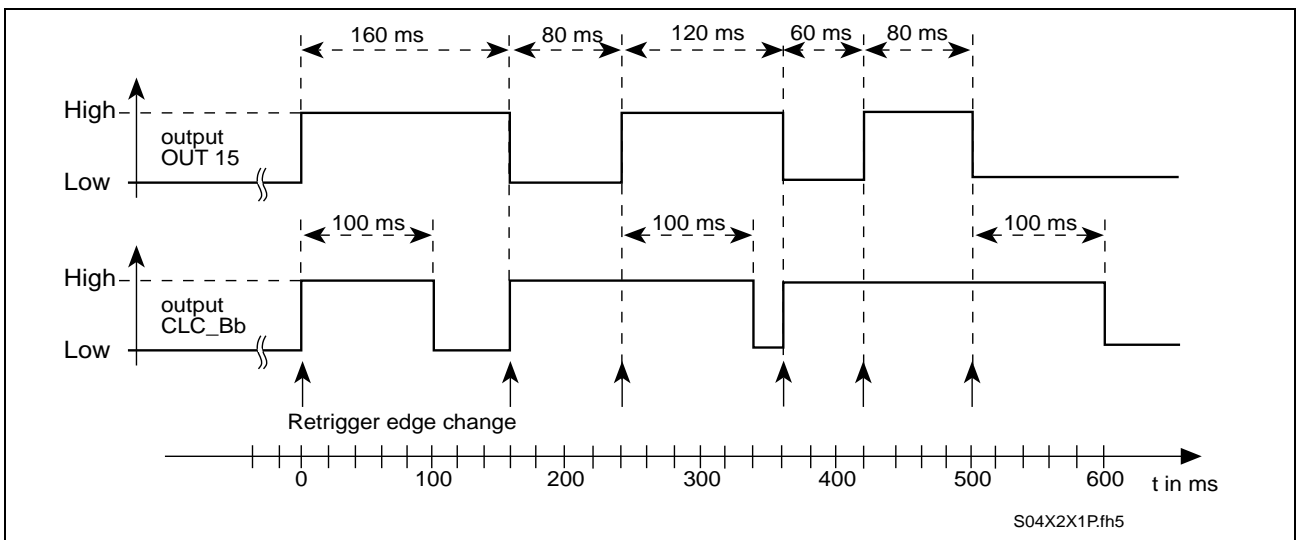

Fig. 14-5: Illustration - how output CLC_Bb works

15 Input / output interface DEA28.1, DEA29.1, DEA30.1

15.1 General Information

These plug-in modules have 32 inputs and 24 outputs each and a CLCBb output. The plug-in modules are inserted into control card CLC-D... (see illustration below).

Up to three DEAs can be inserted into the CLC-D....

The difference between the plug-in modules is their address range and the designations of their plug-in connections.

To avoid confusion during installation, the plug-in connections have been labelled differently.

Allocation of the DEAs to the CLC-D ...

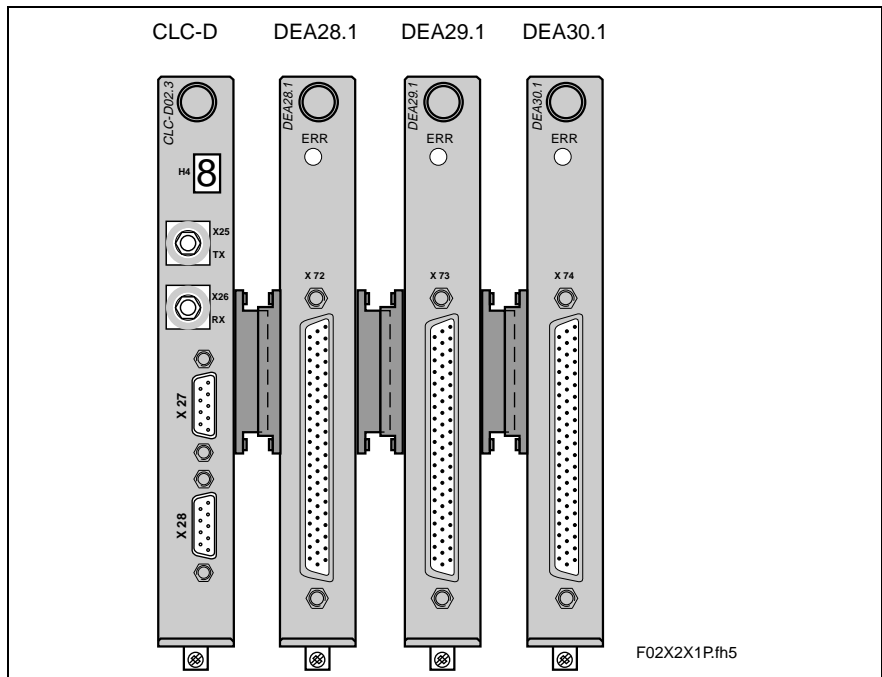

Fig. 15-1: Allocation of the DEAs to the CLC-D ...

The inputs and outputs are isolated. An external power supply of DC +24 volts must be connected. The power supply input is protected against polarity reversal.

15.2 Terminal Diagram

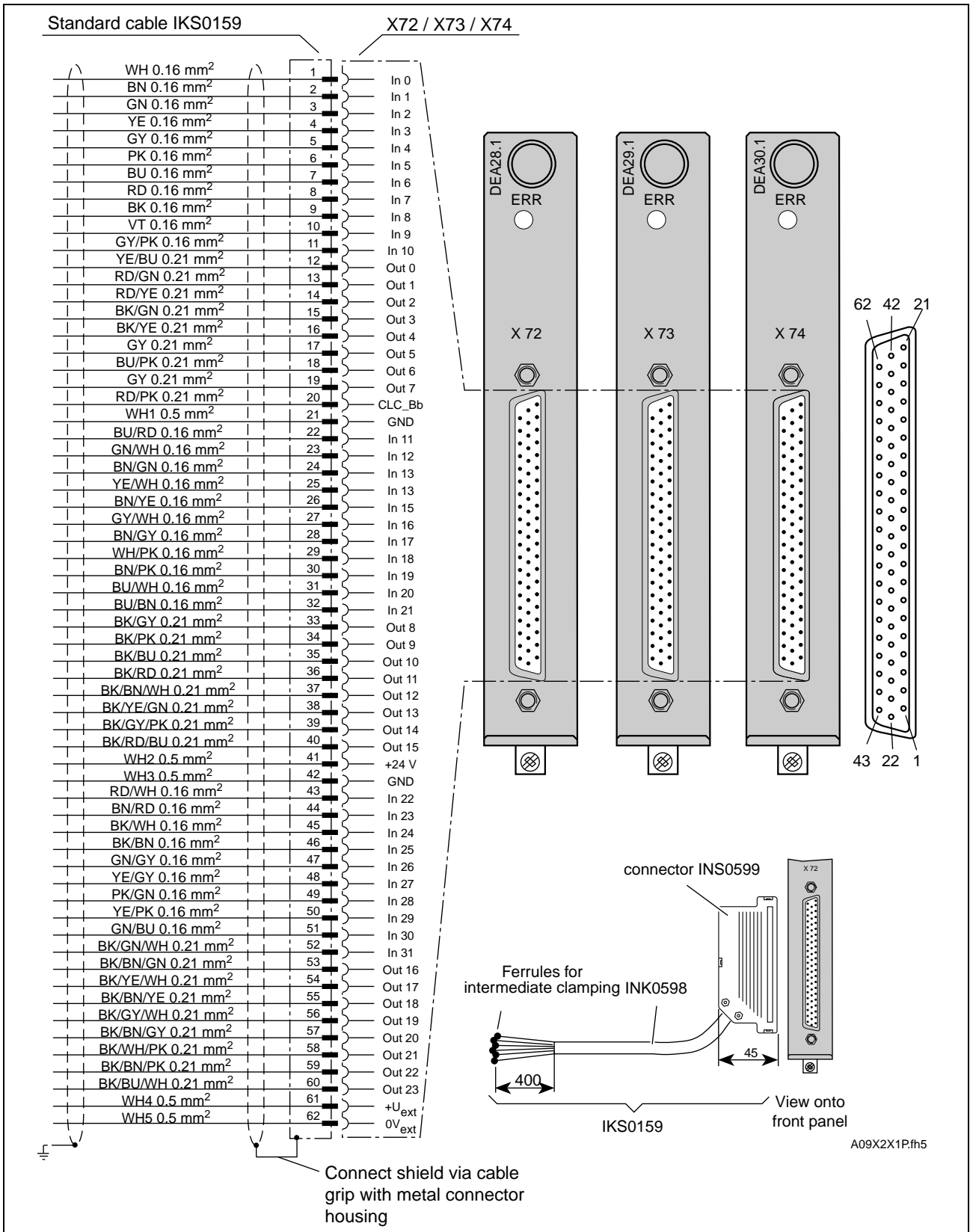

Fig. 15-2: Terminal Diagram DEA28.1, DEA29.1, DEA30.1

15.3 Technical data - DEA28.1, DEA29.1, DEA30.1

Technical Data

Designation		Unit	min.	type	max.
Power supply	+U _{ext}	V	18	24	32
Current consumption	I _{ext}	A	0,15	0,2 ¹⁾	2,2 ²⁾
Inputs IN 0...IN 31	+U _{High}	V	14	24	32
	+U _{Low}	V	0	<1	3
Outputs	+U _{high}	V	U _{ext} -2	U _{ext} -1	U _{ext}
OUT 0...OUT 23	+U _{low}	V	0	1,6	2
CLCBb	I _L	mA	0	-	80 ³⁾

1) Current consumption of 0.2 A without loading outputs at 24 V
 2) Current consumption of 2.2 A, loading all outputs with 80 mA each
 3) The lamp control necessitates that the making current is limited by means of resistance, e.g., 100 R, to 250 mA as otherwise the overvoltage monitor is actuated and the output locked.

Fig. 15-3: Technical data - DEA28.1, DEA29.1, DEA30.1

Schematic diagram - digital input and output circuits

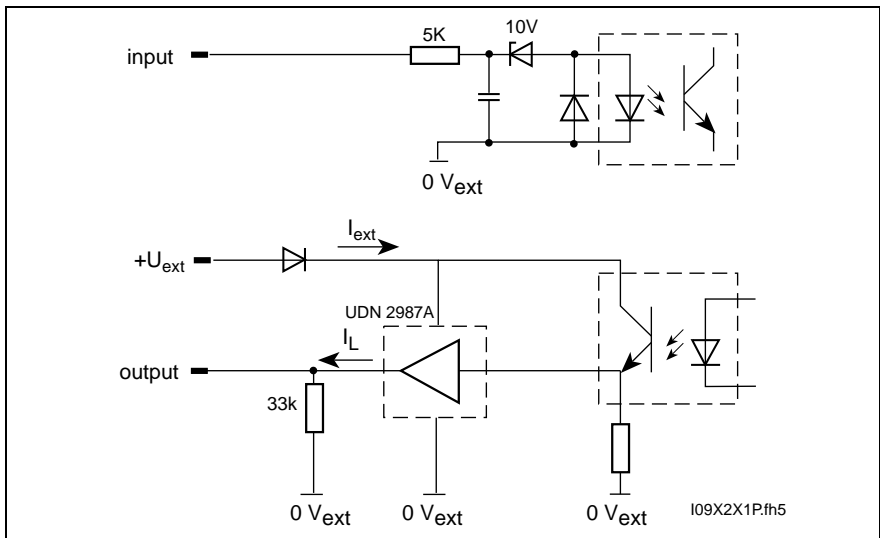

Fig. 15-4: Schematic diagram - digital input and output circuits

Recommended load inductance circuit

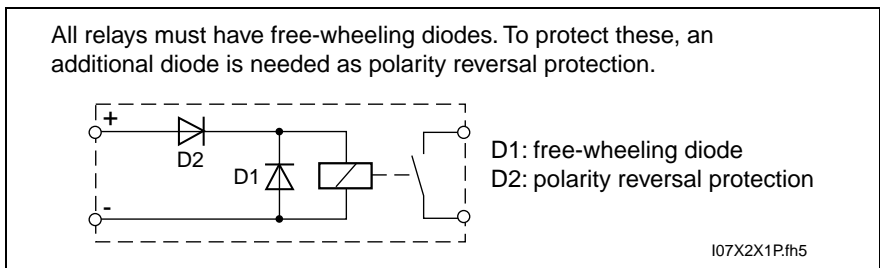

Fig. 15-5: Recommended load inductance circuit

Note: The driver UND 2987 A limits short-circuit currents to 350mA.

If short-circuit limits exceed 1µs, then the effected output is closed (I_L=0). The other outputs can function. The affected output remains locked until the power supply has been switched off and on once.

Note: If driver UND 2987 A has switched off one or more outputs due to overload, then the error state will be displayed by the LED which has been switched on.

Output CLC_Bb

Output CLC_Bb is set to high with each edge change of output OUT15. Output CLC_Bb remains at high for 100ms. If the state of output OUT15 does not change during this time, then output CLC_Bb goes back to low. If the state of the output OUT15 is altered during this 100 ms period, then output CLC_Bb is retriggered and remains in the high state.

Retrigger time: 100 ms

Application:

Output CLC_Bb can be used as a kind of "Watchdog".

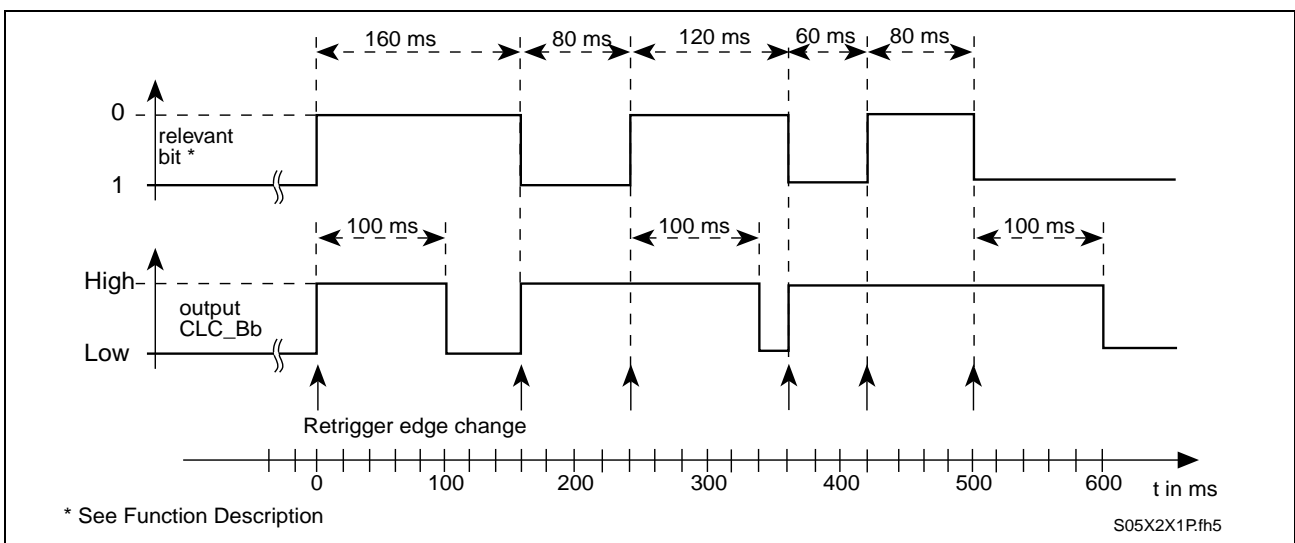

Fig. 15-6: Illustration - how output CLC_Bb works

16 Position Interface for Square-Wave Signals DEF01.1 and DEF02.1

16.1 General Information

"Incremental position interface" modules support the acceptance of square-wave signals to detect measuring systems directly and externally mounted to machine elements in the drive controller.

The incremental position interfaces DEF01.1 and DEF02.1 for square-wave signals differ in that they react to different address ranges. These ranges are automatically divided up during the initialization phase to the inserted position interface.

To avoid confusion during installation, the D-subminiature plug-in connectors are labelled differently.

16.2 DEF01.1 and DEF02.1 Connector Assignments

Connector assignment -
position interfaces for square-
wave signals
DEF01.1 = X22
DEF02.1 = X24

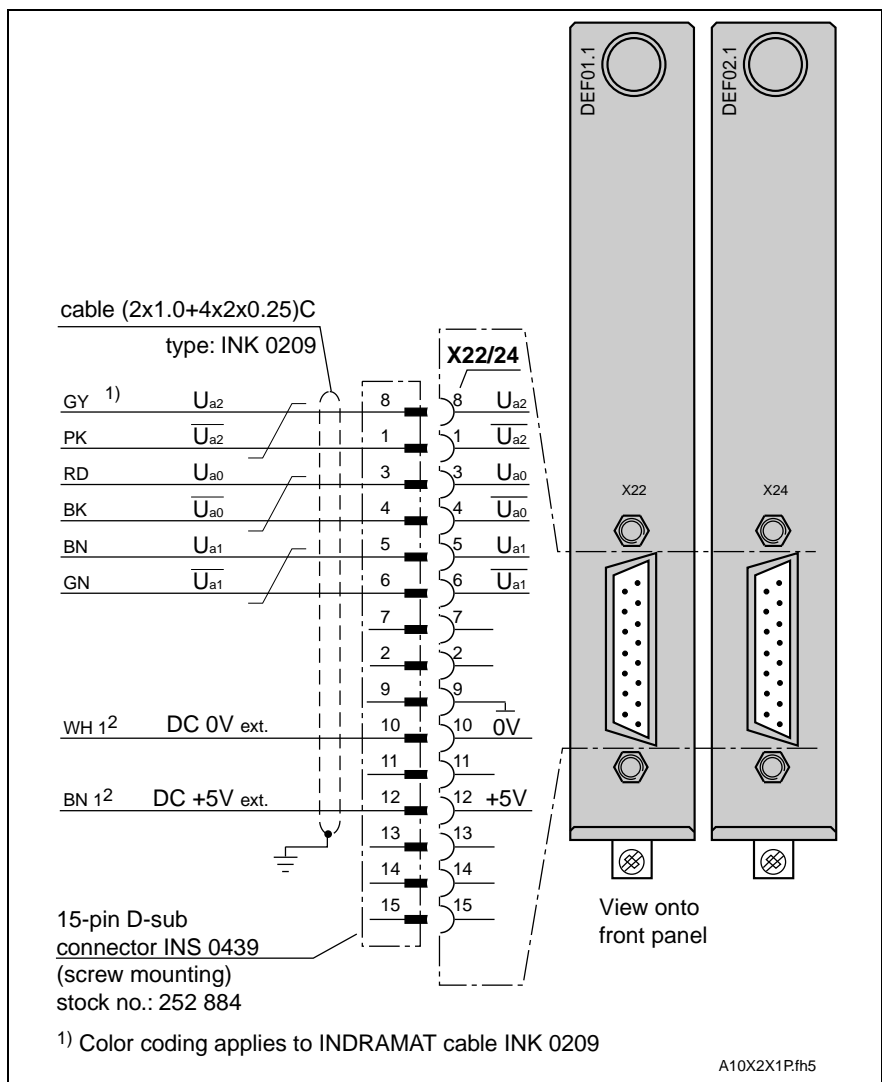

Fig. 16-1: Connector assignment position interface for square-wave signals DEF01.1 and DEF02.1

16.3 Technical data - DEF01.1 and DEF02.1

Power supply of the external measuring system

Designation	Unit	min.	type/ value	max.
Output voltage +5 V	V	4.75	5	5.25
Output current - +5 V	mA			250

Fig. 16-2: Power supply of the external measuring system

Voltage level and phase angle - input signals

Designation		Unit	min.	type/ value	max.
Signal voltage	U_{High}	V	2,5		
	U_{Low}	V			0.5
Phase angle	U_{a1}	°el.		0	
	U_{a2}	°el.		90	
Max. input frequency		kHz			1000
Interpolation - signal period				4-fold	
Reference point delay t1		ns			50
Edge distance t2		ns	250		

Fig. 16-3: Voltage level and phase angle - input signals

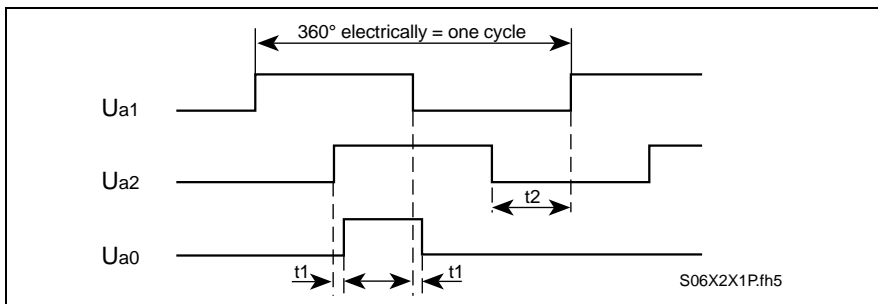

Fig. 16-4: Schematic diagram - signal paths

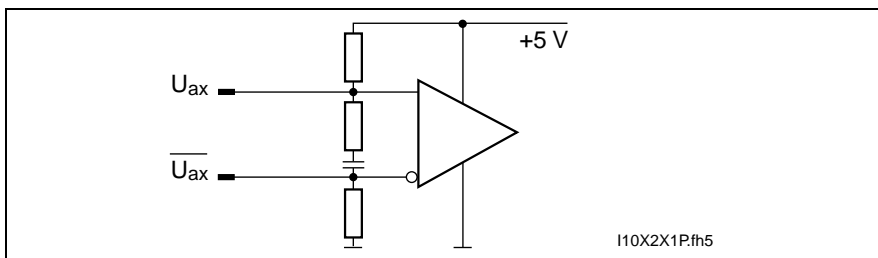

Fig. 16-5: Schematic diagram - input circuit

17 Encoder Interface DFF01.1

17.1 General Information

Plug-in module "Encoder interface DFF01.1" supports position detection of measuring systems GDS01.1 / GDM01.1 mounted directly to the motion machine elements.

Application example:

The single-turn encoder interface DFF01.1 supports the connection of main shaft encoder GDS01.1 to a digital drive controller and for relaying encoder signals to other drive controllers.

Application:

- electronic shafts
- synchronization of drives on main shaft encoders

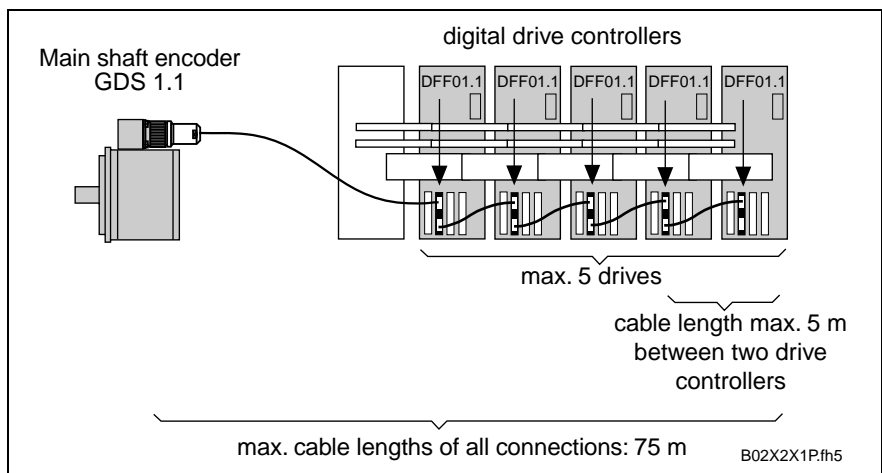

Fig. 17-1: Allocation - DFF01.1

17.2 Terminal Diagram

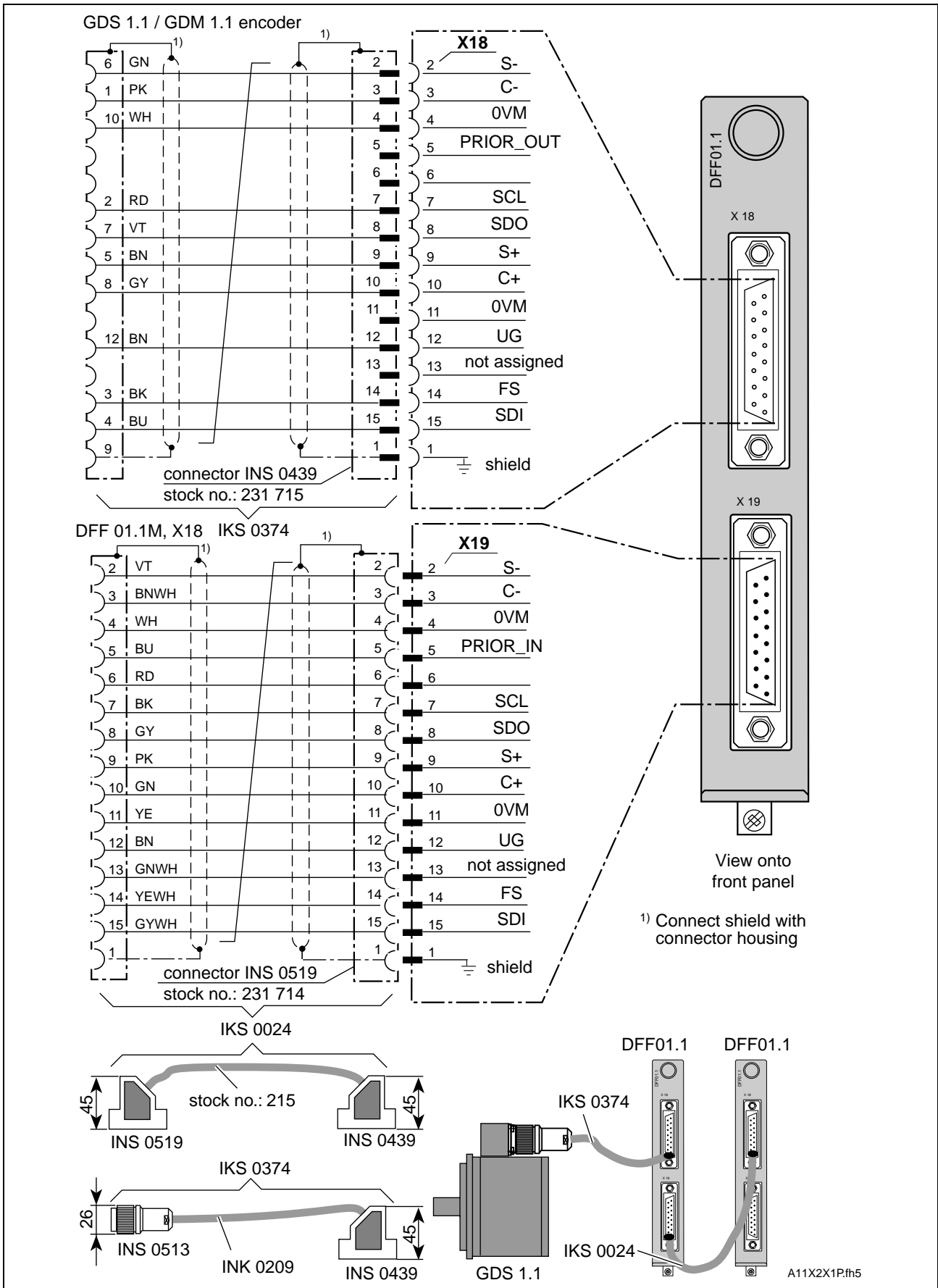

Fig. 17-2: Terminal Diagram DFF01.1

18 Positioning Module DLC01.1

18.1 General Information

Plug-in module „Single-axis positioning module DLC01.1“ expands the drive controller to become a stand-alone single-axis positioning control unit which can be programmed with up to 3000 program sets. Each set describes a motional sequence or a specific state of inputs to be monitored or outputs to be set.

18.2 Terminal Diagram

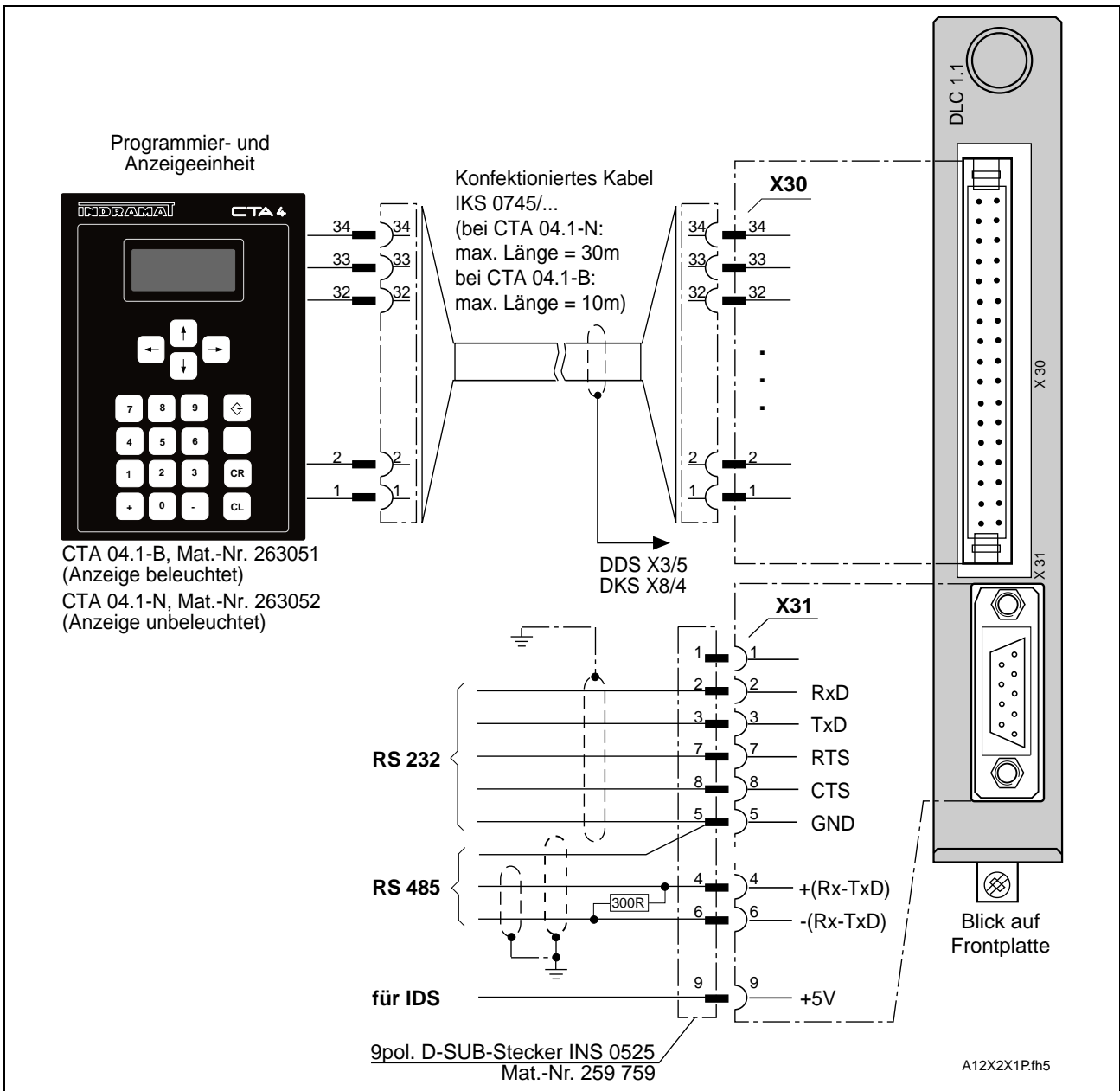

Fig. 18-1: Terminal Diagram DLC01.1

Terminal diagram - data interface

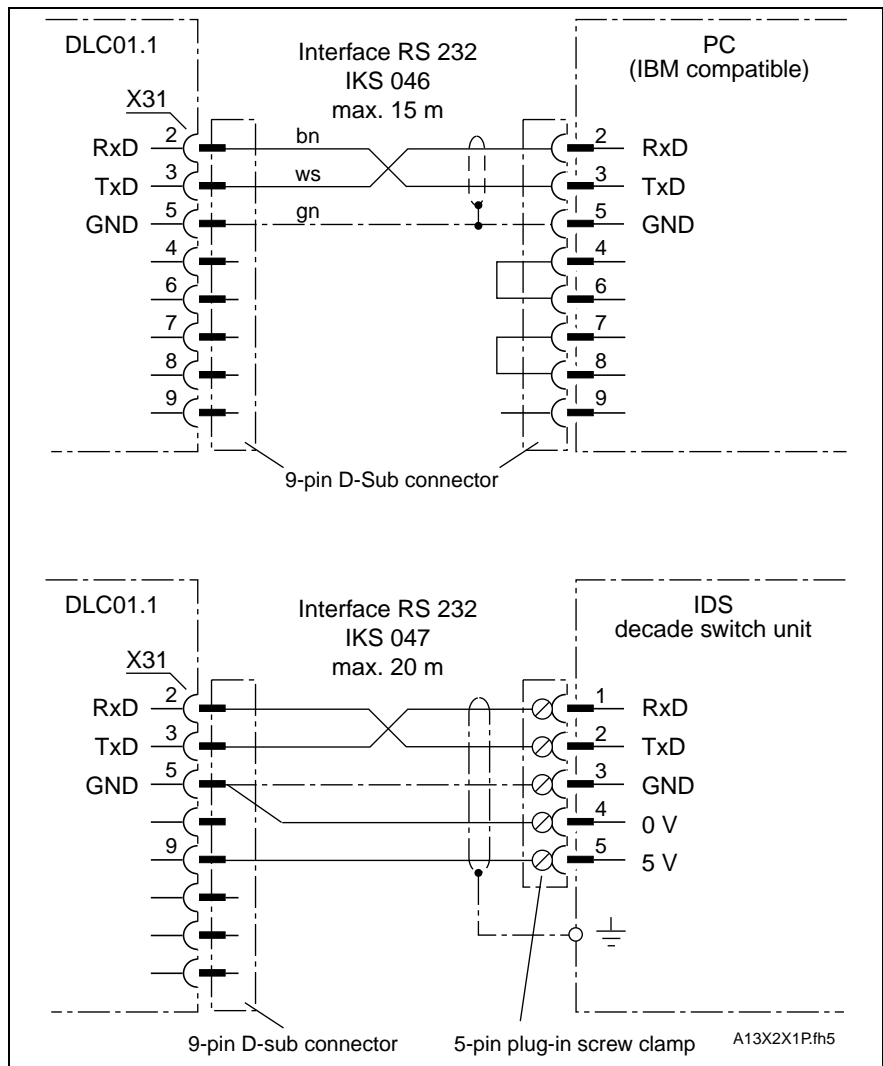

Fig. 18-2: Terminal diagram - data interface RS 232

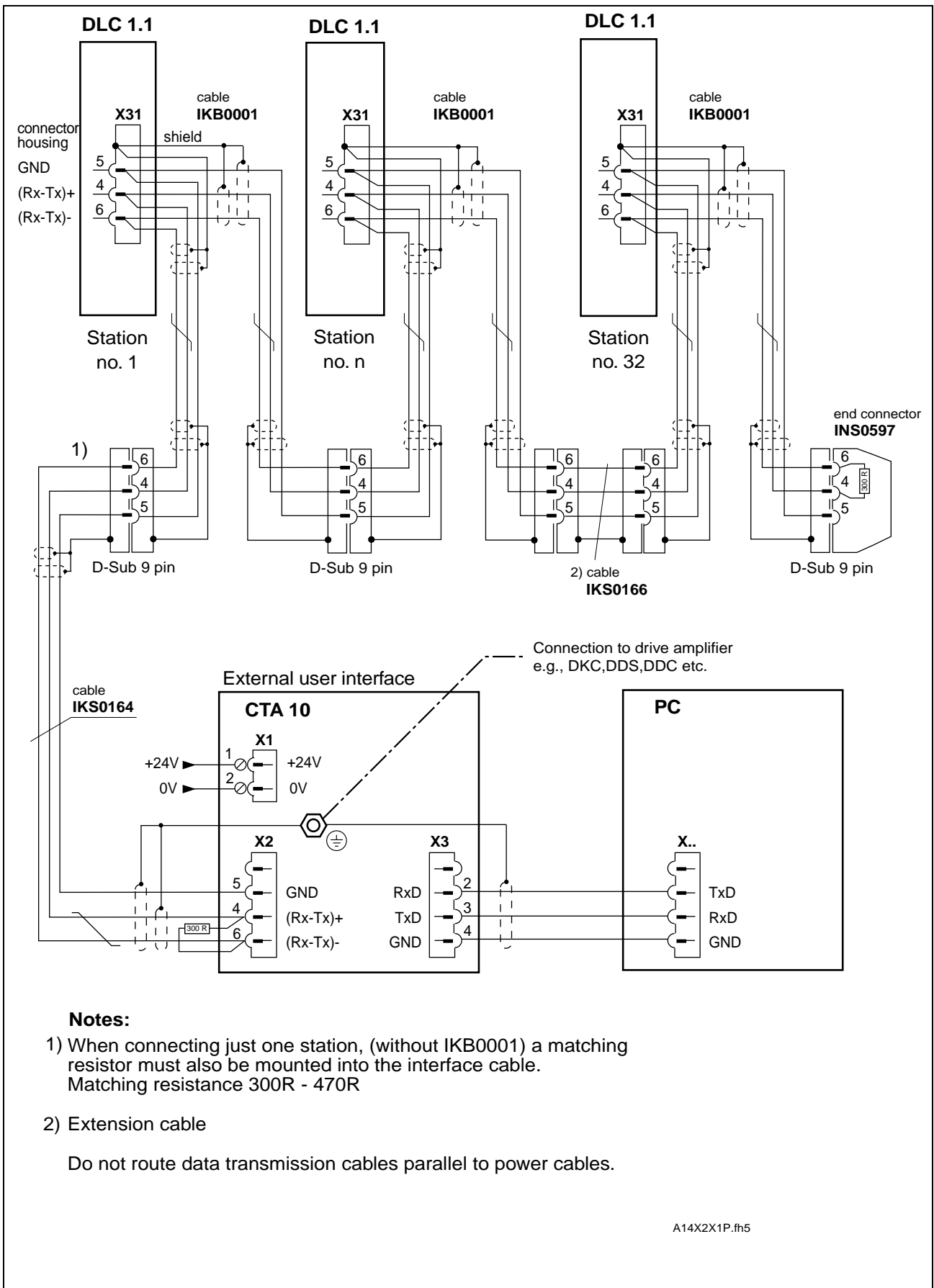

Fig. 18-3: DLC-RS 485

Note:

19 Positioning Module DLC02.1-FW

19.1 General Information

The plug-in positioning module DLC02.1-FW expands the drive controller to create a stand-alone single-axis positioning NC control unit which can be programmed with up to 3000 programming blocks. Each block describes one motional sequence or a specific state of inputs to be monitored or outputs to be set.

Positioning module DLC02.1-FW is only operated with INTERBUS-S interface module DBS02.2-FW.

INTERBUS-S interface module DBS02.2-FW is inserted into the positioning module DLC02.1-FW. Once screwed into place with three bolts, the DBS02.2 and DLC02.1 become one unit.

Note: Please note, when disassembling or removing the plug-in module from the drive controller that the DBS02.2-FW is connected with the DLC02.1-FW.

19.2 Terminal Diagram

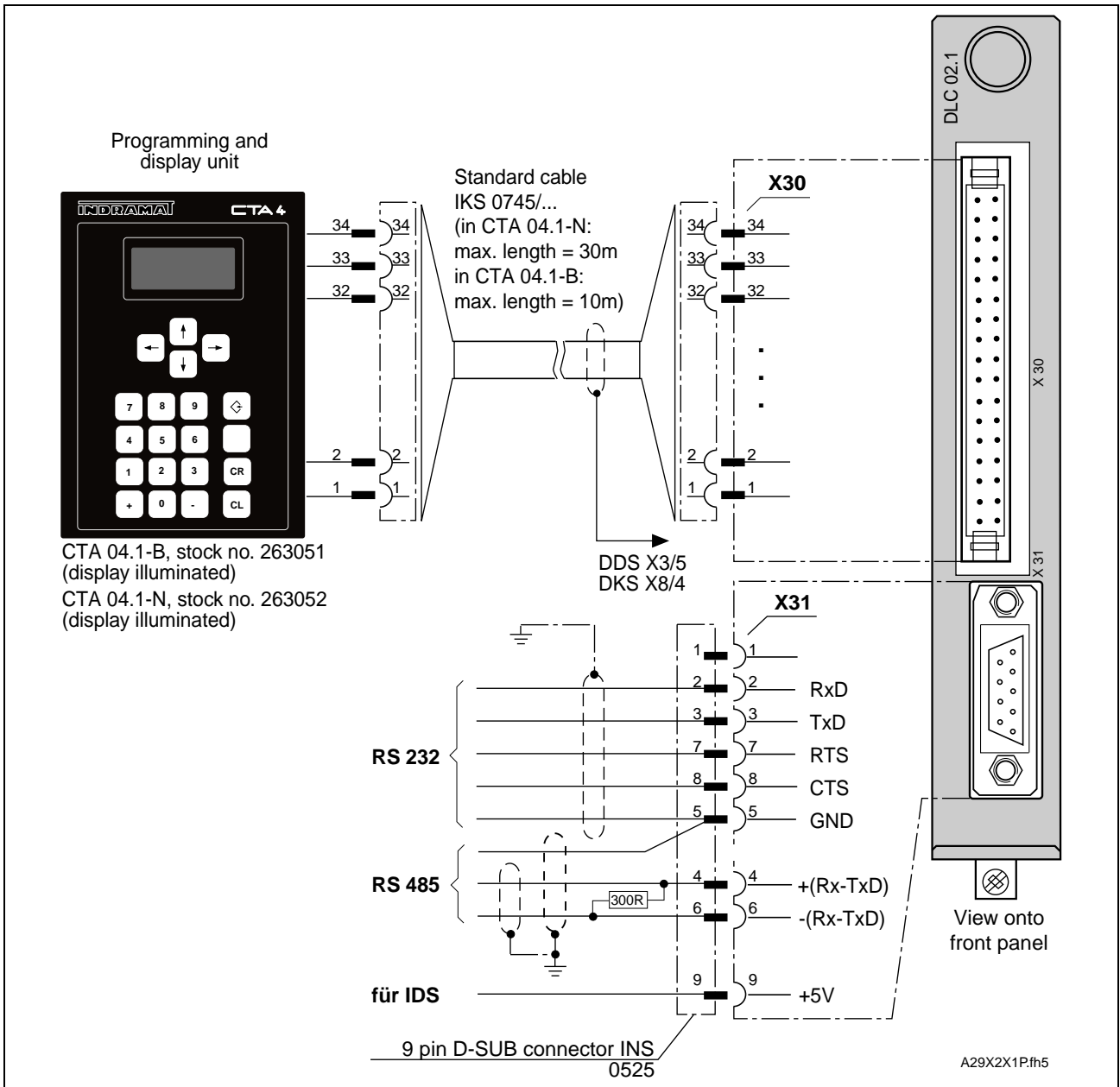

Fig. 19-1: Terminal Diagram DLC02.1-FW

Terminal diagram
- data interface

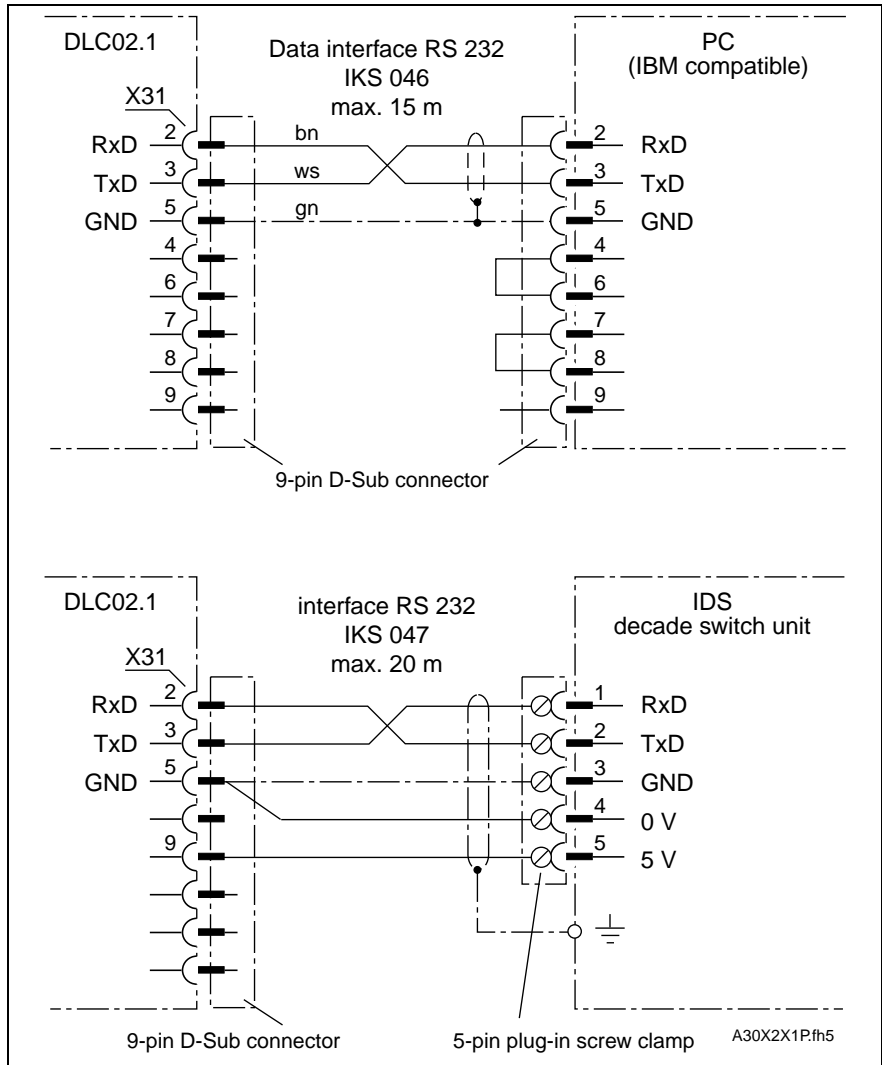

Fig. 19-2: Terminal Diagram - data interface RS 232

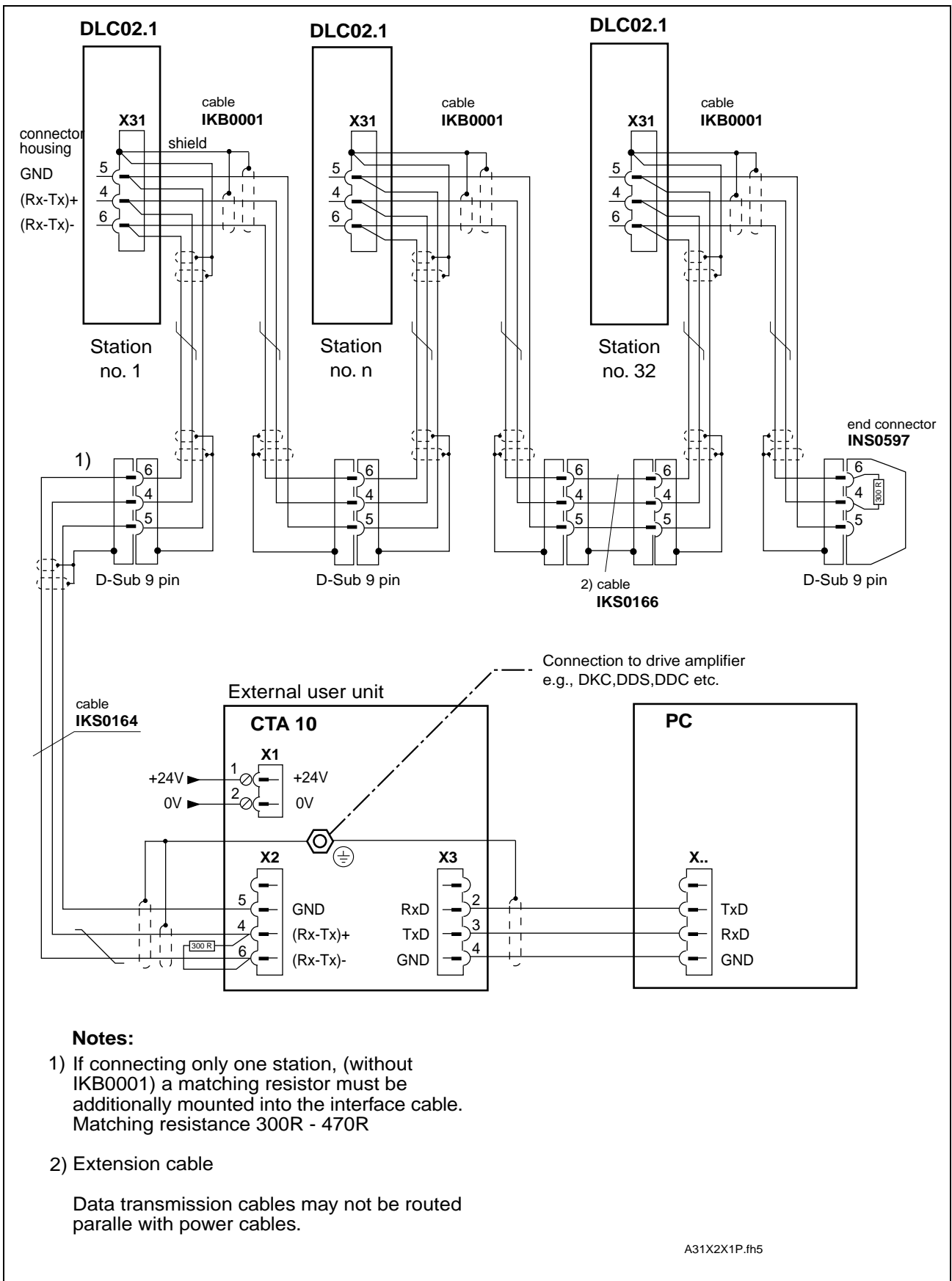

Fig. 19-3: SOT - DLC RS 485 with up to 32 stations

20 High-Resolution Position Interface for Sine Signals DLF01.1

20.1 General Information

Measuring systems Plug-in module "High-resolution position interface DLF01.1" supports the acceptance of sine signals for position detection of external measuring systems directly mounted to moving machine elements.

The high-resolution position interface DLF01.1 evaluates measuring systems with

- sinusoidal **current** signals (7 ... 11 μ Ass) or with
- sinusoidal **voltage** signals (1 V_{SS}).

Switching from current to voltage signals By bridging X23/1 and X23/12 in the connector of the DLF01.1-plug-in module, the DLF01.1 is set to the evaluation of voltage signals.

If there is no such connection, then the DLF01.1 is set to evaluate current signals.

20.2 Terminal diagrams

Terminal diagram for measuring systems with voltage signals

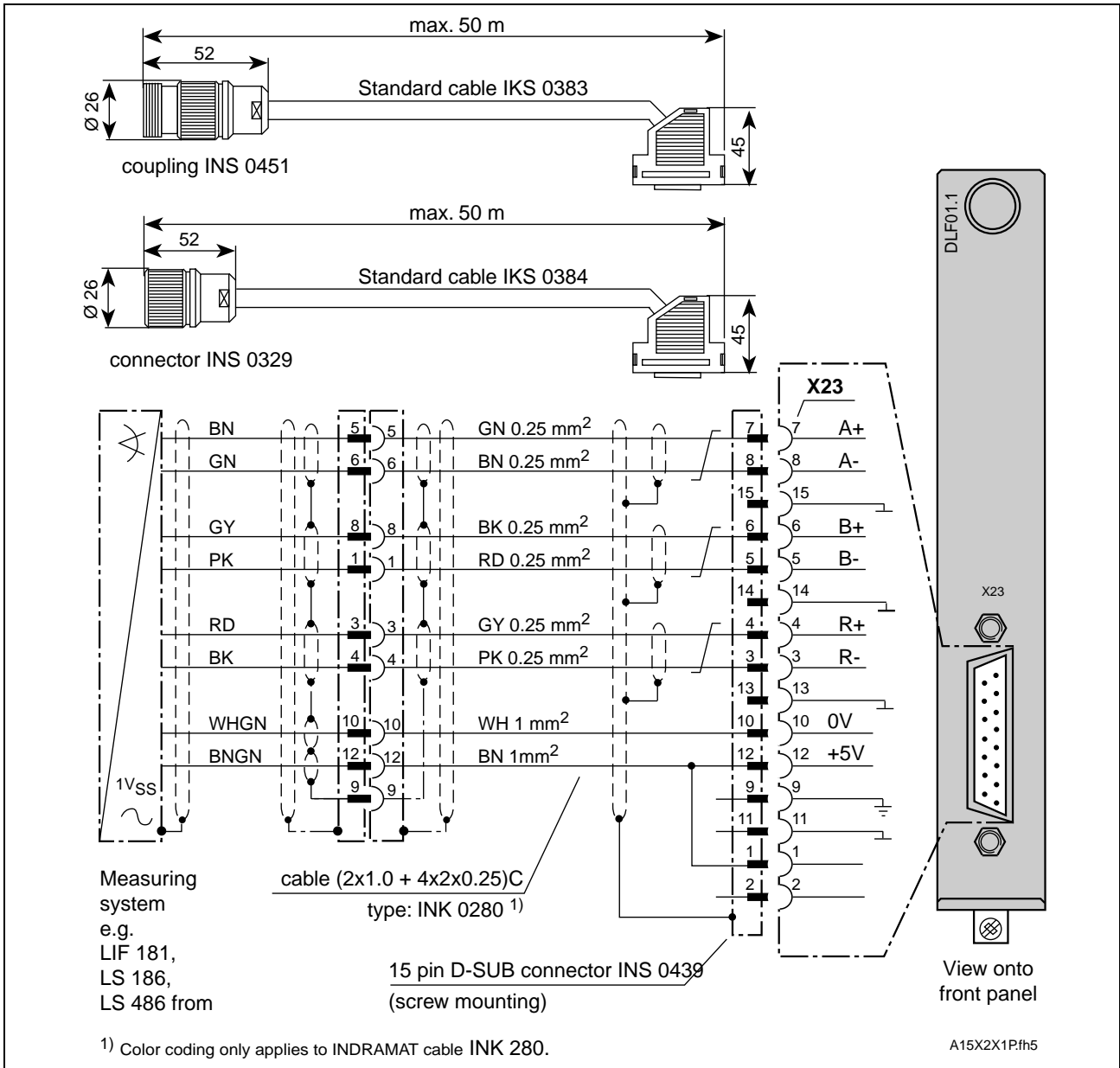

Fig. 20-1: Terminal diagram for measuring systems with voltage signals

Signal breakdown of measuring systems with voltage signals

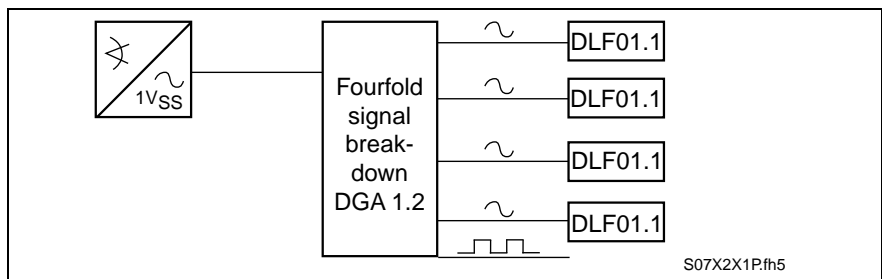

Fig. 20-2: Signal breakdown of measuring systems with voltage signals

For further information, see encoder junction DGA01.2 (pg.29-1).

Terminal diagram for measuring systems with current signals

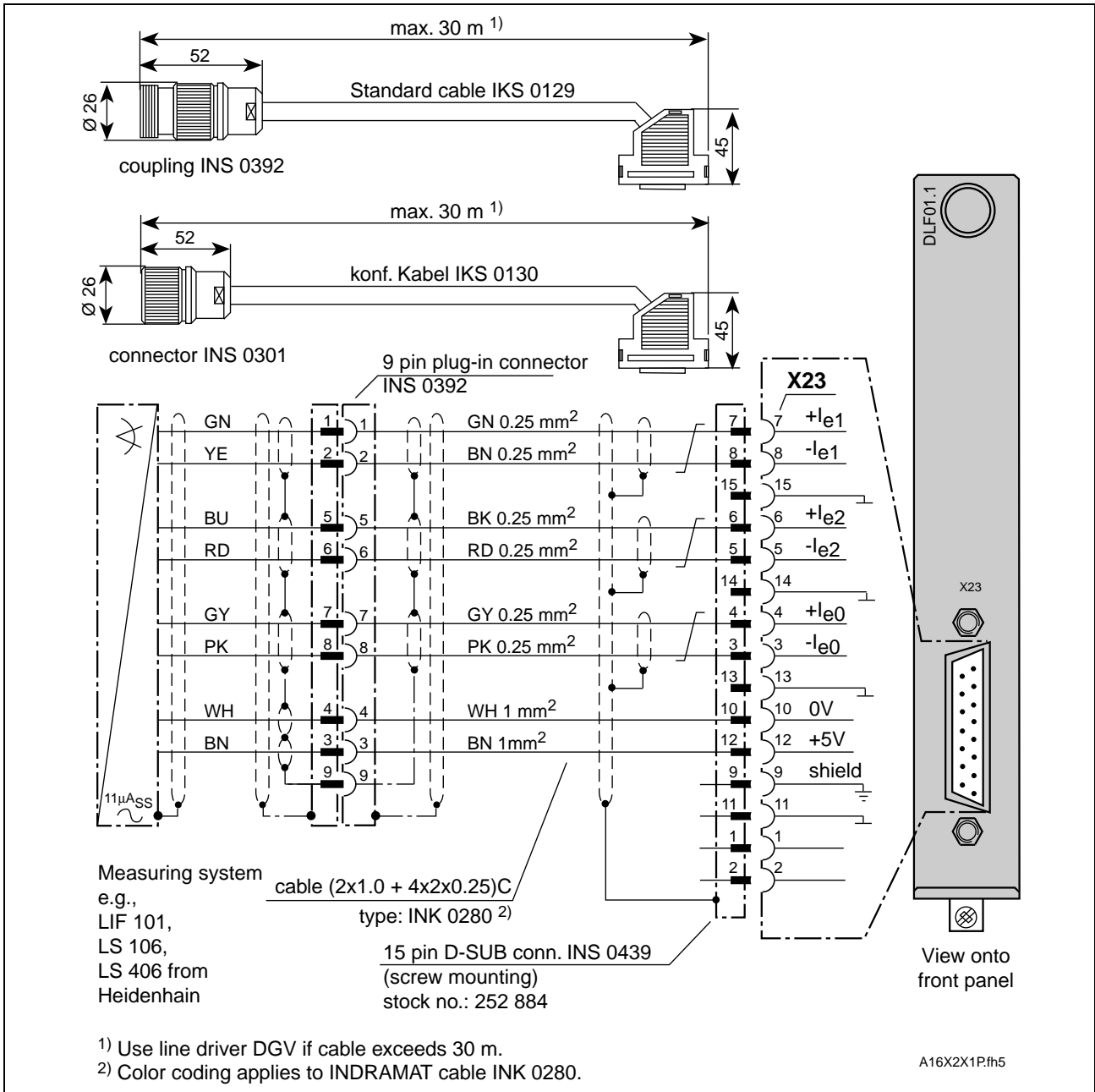

Fig. 20-3: Terminal diagram for measuring systems with current signals

A cable length of >30m needs line driver DGV01.1 (see pg. 29-6).

20.3 Technical data - DLF01.1

Power supply for external measuring system	Output voltage X23/12:	DC +5 V ($\pm 5\%$)
	Max. load of outputs X23/12:	150 mA
Signal form	Approximate sinusoidal signals.	
Resolution	The signal periods supplied by the measuring system has a 2048fold resolution.	
Voltage signals	Signal voltage:	A, B, R 1 V_{SS}
	Max. frequency for meas. sys. signals:	A, B 500 kHz
	Max. frequency for reference signals:	R 15 kHz
Current signals	Signal current:	I_{e1}, I_{e2} 7...16 μA_{SS}
		I_{e0} 2...8 μA_{SS}
	Max. frequency for meas. sys. signals:	I_{e1}, I_{e2} 150 kHz
	Max. frequency for reference signals:	I_{e0} 15 kHz

Signal input circuit

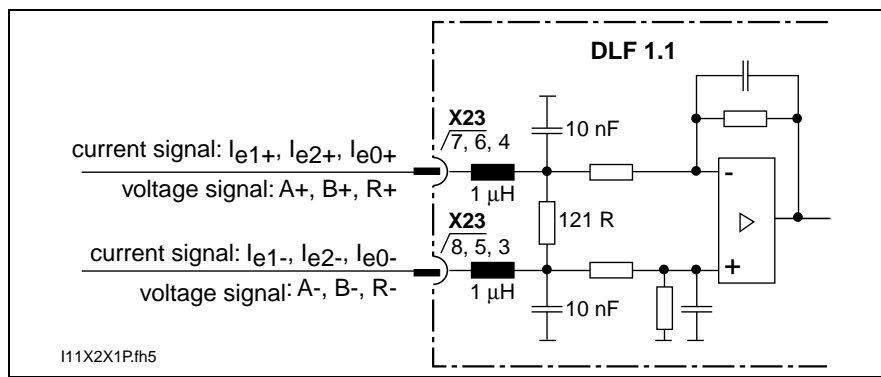

Fig. 20-4: Signal input circuit

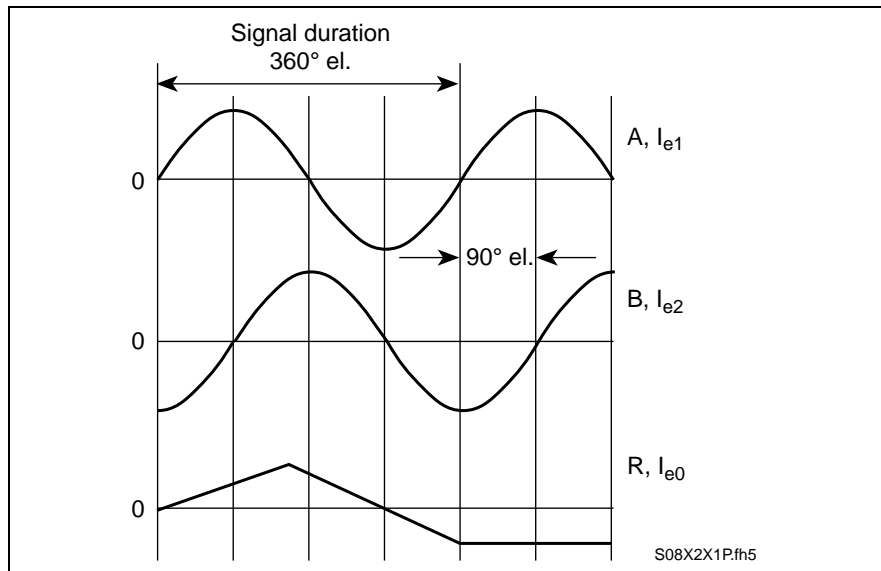

Fig. 20-5: Schematic diagram - signal paths

21 Profibus Interface DPF02.1/03.1/04.1

21.1 General Information

With a Profibus interface it is possible to connect I/O subassemblies.

The Profibus interface can, e.g., be used with positioning module DLC01.1-FW enabling the integration of DLC positioning modules into a Profibus system.

The design of module DPF02.1/03.1/04.1 as a Profibus DP slave module makes the integration into a Profibus network of the Profibus category DP as per DIN 19245-3 possible.

Plug-in modules DPF02.1, DPF03.1 and DPF04.1 vary in terms of their address ranges, connector designations, address selection switch designation for the Profibus and the designations for the LED displays.

Profibus interface	Connector	Address selection switch	LED displays
DPF02.1	X55	S8, S9	H8
DPF03.1	X56	S10, S11	H9
DPF04.1	X57	S12, S13	H10

Fig. 21-1: Differences - Profibus interface plug-in modules

Bus addresses The participant addresses on the Profibus are set with both BCD coded rotary switches. Addresses of between 1 and 99 (decimal) may be set on the plug-in module.

LED display The LEDs H8/H9/H10 glow green if the "Bus is running".

PNO number and machine trunk file The „Profibus User Organization (PNO)“ distributes a hexadecimal number with four places for the machines to be certified. This enables the Profibus master to allocate equipment trunk files with interface data to the slave. The plug-in cards DPF02/3/4 receive the numbers **1346**.

The relevant machine trunk data file is named **DKC31346.GSD**. The file entails, in text form, the parametrization data for the Profibus. It can be obtained via the Indramat mailbox.

There are type files in this mailbox also (*.200) for the Siemens NC control units which are not compatible to the Profibus. There are two variants of these. One is for a DOS configurator, version 4, the other for Windows configurator, version 5.

21.2 Terminal Diagram

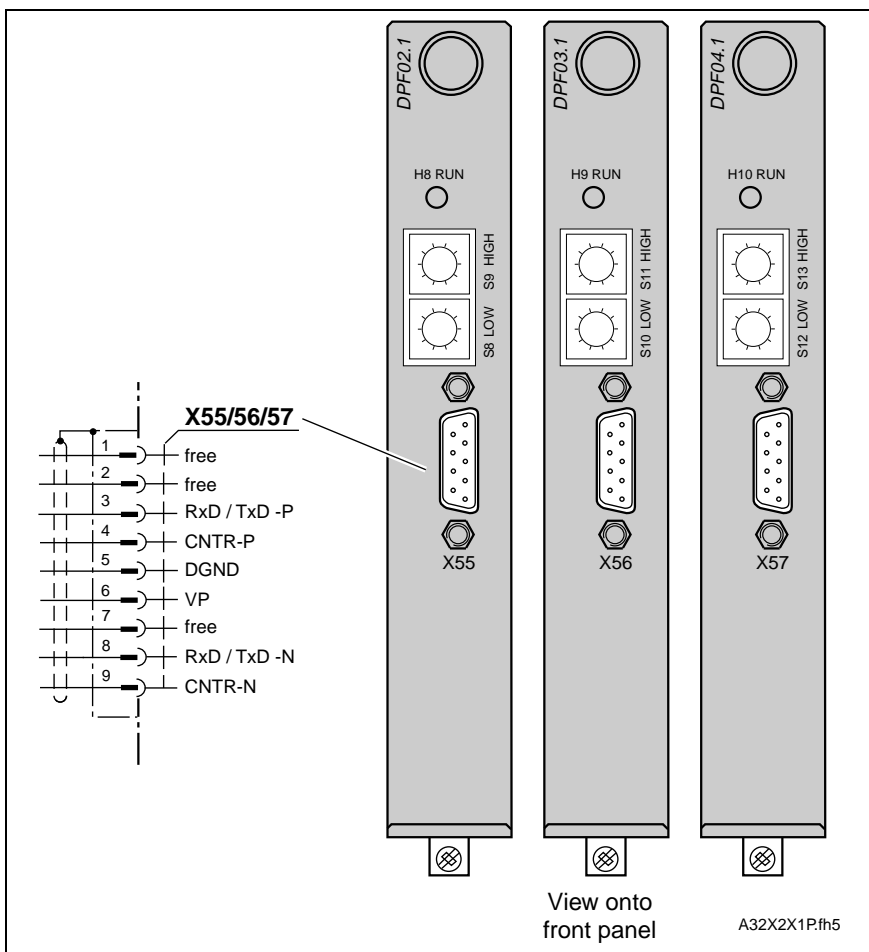

Fig. 21-2: Terminal Diagram DPF02.1, DPF03.1, DPF04.1

21.3 Technical Data

Profibus interface

Profibus interface as per DIN 19245, section 1 with cable termination for cables of category A or B per DIN 19245, section 3.

The Profibus cable is connected at X55, X56 and/or X57. The connector is generally not part of the overall delivery but must be ordered separately.

The PROFIBUS connectors each contain a switchable matching resistor. This resistor must be switched at the first and last bus participant. Do not confuse cores A and B. Terminate as illustrated below.

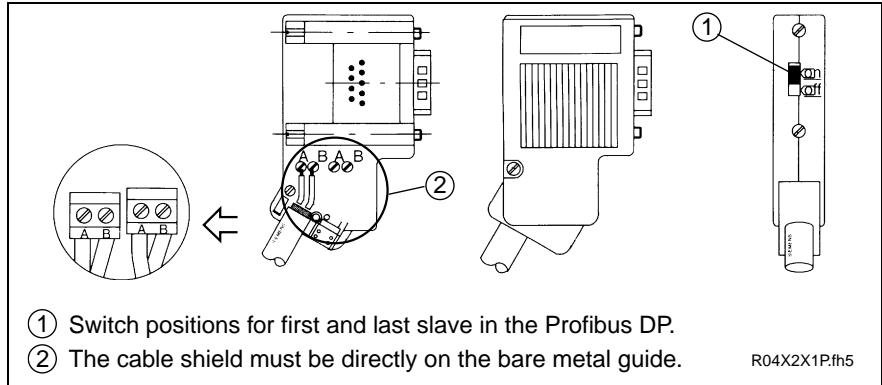

Fig. 21-3: Bus connection for first and last slave, bus connector INS0450 without 9-pin D-subminiature bushing

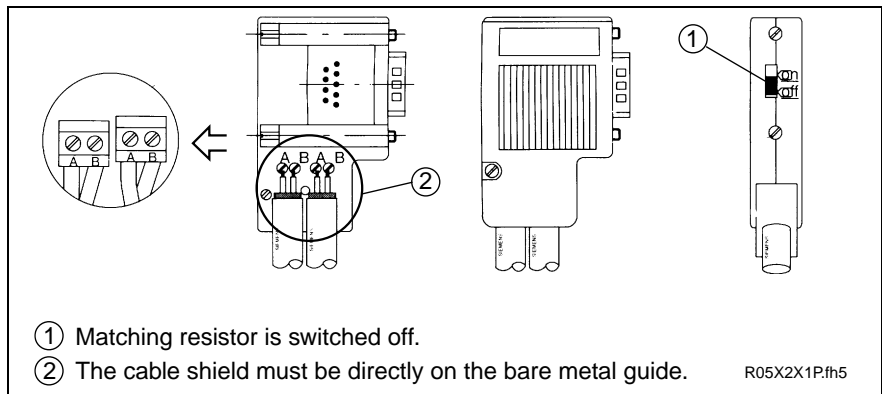

Fig. 21-4: Bus connection for all other slaves, bus connector INS0450 without 9-pin D-subminiature bushing

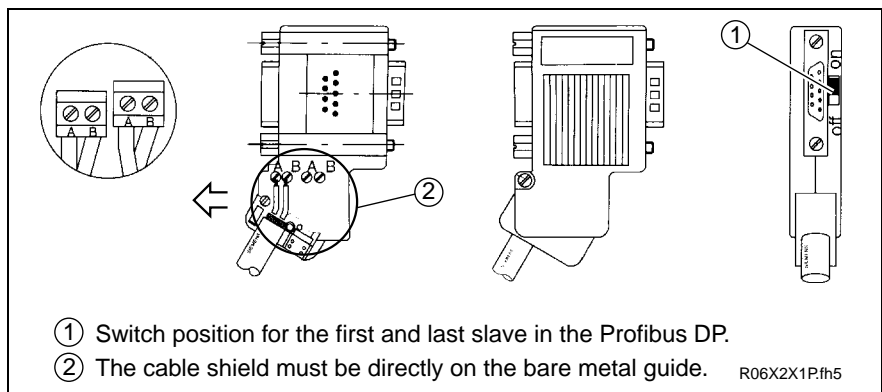

Fig. 21-5: Bus connection for first and last slave, bus connector INS0541 with 9-pin D-subminiature bushing

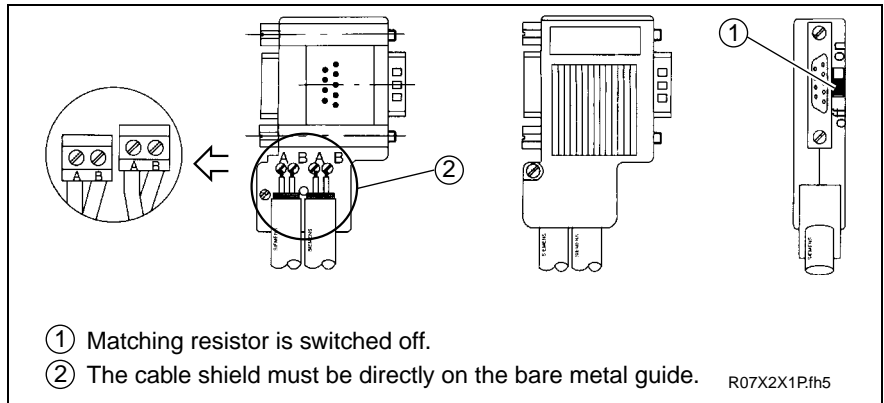

Fig. 21-6: Bus connection for all other slaves, bus connector INS0541 with 9-pin D-subminiature bushing

The DPF connection must implement a shielded two-core line as per DIN 19245, section 1.

Pre-assigned bits in DPF02

If Profibus interface DPF02.1 is used together with positioning module DLC01.1-FW, then specific data bits are pre-defined.

Input / output	Bit no	Signal	Definition if 1 =	if 0 =
Input	0	parameter	parametrize	
Input	1	automatic	automatic	set-up
Input	2	/E-stop	E-stop	OK
Input	3	start	start	
Input	4	/stop	run	stop
Input	5	jogging forwards	jogging forwards	
Input	6	jogging backwards	jogging backwards	
Input	7	clear	clear error	
Output	0	/fault	OK	error
Output	1	set-up	set-up mode	
Output	2	automatic	automatic mode	
Output	3	parameter	parametrization mode	
Output	4	automatic program	automatic program running	

Fig. 21-7: Pre-defined bits - DPF02 with DLC

22 Profibus Interface DPF05.1-FW

22.1 General Information

Profibus Interface DPF05.1-FW enables the integration of control module CLC-D into a Profibus system. The design of the module as a Profibus DP combi slave module makes it possible to integrate into Profibus networks of the category Profibus DP, Profibus FMS or a mixture as per DIN19245-3.

The module DPF05.1-FW has been designed as a plug-in module that can be directly inserted onto the NC control module. Once screwed together with three bolts, it creates one unit with the CLC-D.

Note: Other modules can also be inserted onto the DPF05.1-FW within the system. This is important when disassembling an removing!

22.2 Terminal Diagram

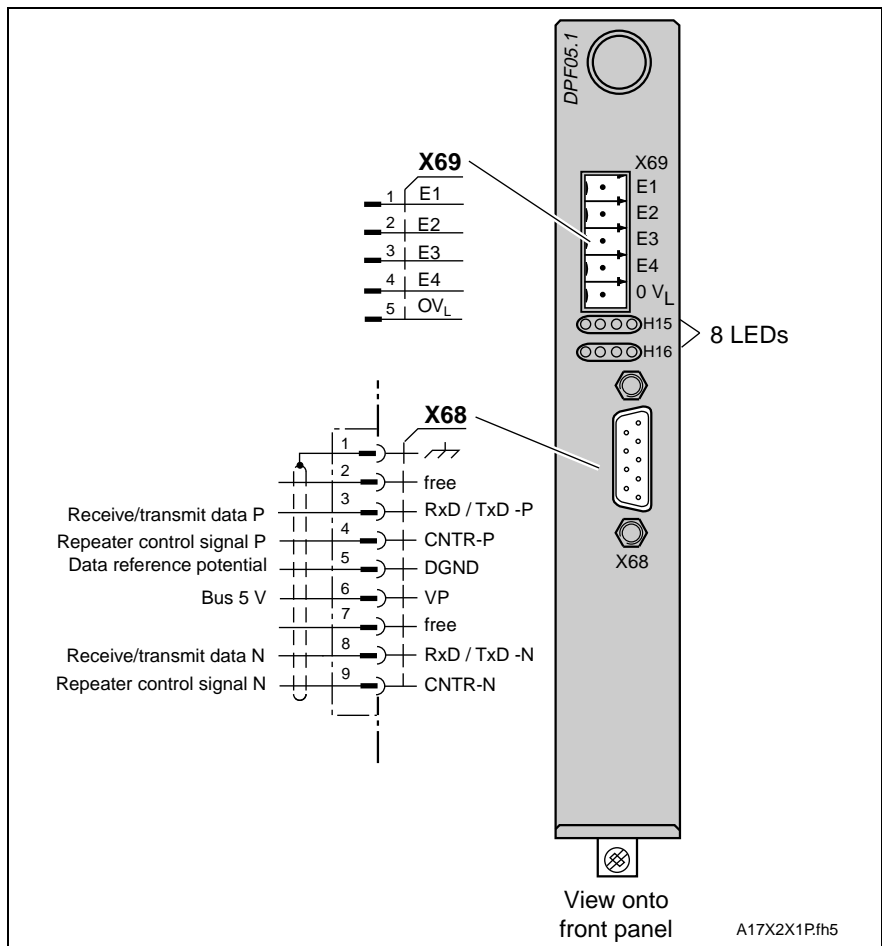

Fig. 22-1: Terminal Diagram DPF05.1M-FW

22.3 Technical Data

External inputs The module DPF05.1 makes four hardware inputs (+24V) available. These inputs can be used in conjunction with the CLC-D if supported by the relevant firmware. The signal states at these inputs are transmitted independent of Profibus status (on/off) to the CLC-D, but the Profibus master can also query them via the PD or FMS channel.

X69	Designation	Input voltage for high	Input voltage for low
1	E1	+16 V... +32 V	-0,5 V ... +8 V
2	E2	+16 V... +32 V	-0,5 V ... +8 V
3	E3	+16 V... +32 V	-0,5 V ... +8 V
4	0V _L	reference potential 0V	reference potential 0V

Fig. 22-2: Signal assignment for X69 external inputs

Profibus interface Profibus interface as per DIN 19245, section 1 with cable termination for cables of category A or B per DIN 19245, section 3. The Profibus cable is connected at connector X68. This cable is not part of the general delivery and must be ordered separately. The PROFIBUS connectors each contain a switchable matching resistor. This resistor must be switched at the first and last bus participant. Do not confuse cores A and B. Terminate as illustrated below.

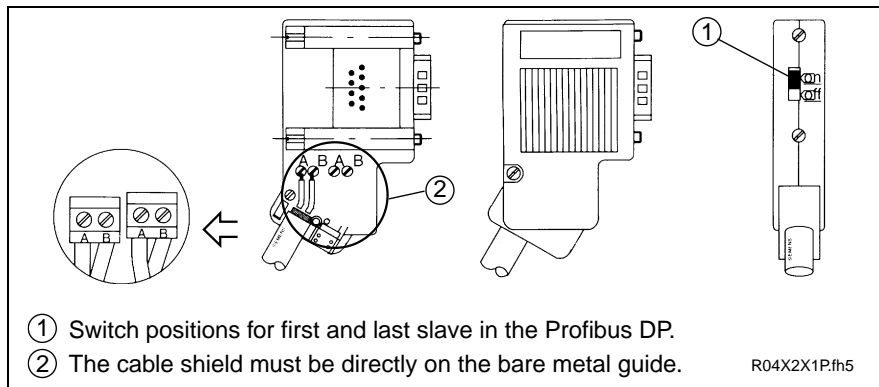

Fig. 22-3: Bus connection for the first and the last slave, bus connector INS0450 without 9-pin D-subminiature bushing

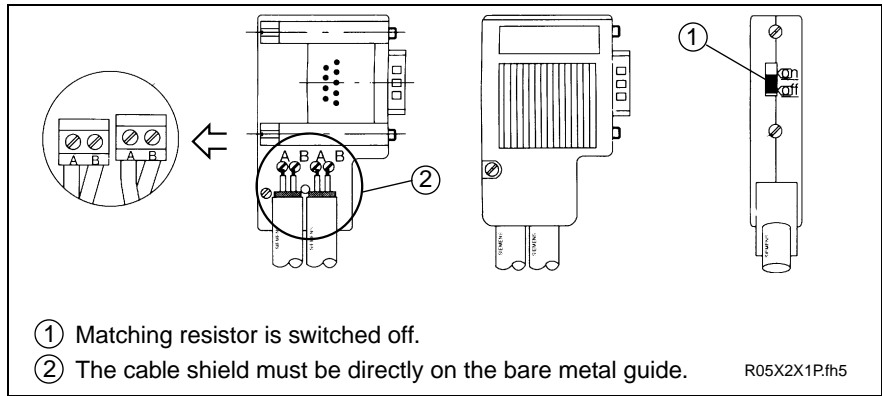

Fig. 22-4: Bus connection for all other slaves, bus connector INS0450 without 9-pin D-subminiature bushing

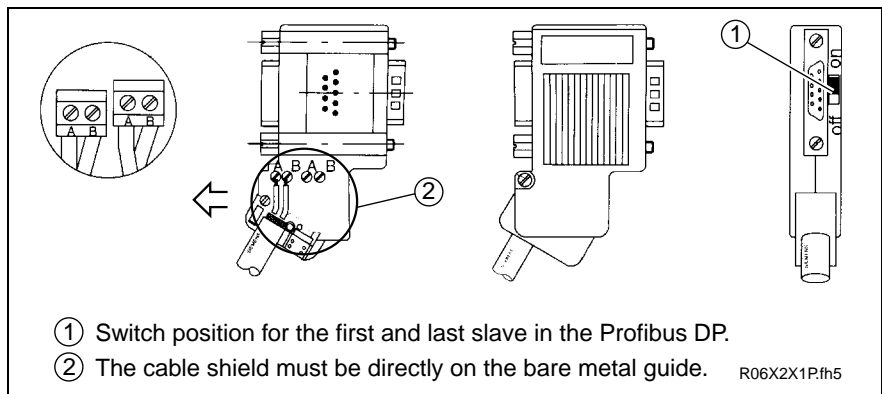

Fig. 22-5: Bus connection for the first and the last slave, bus connector INS0541 with 9-pin D-subminiature bushing

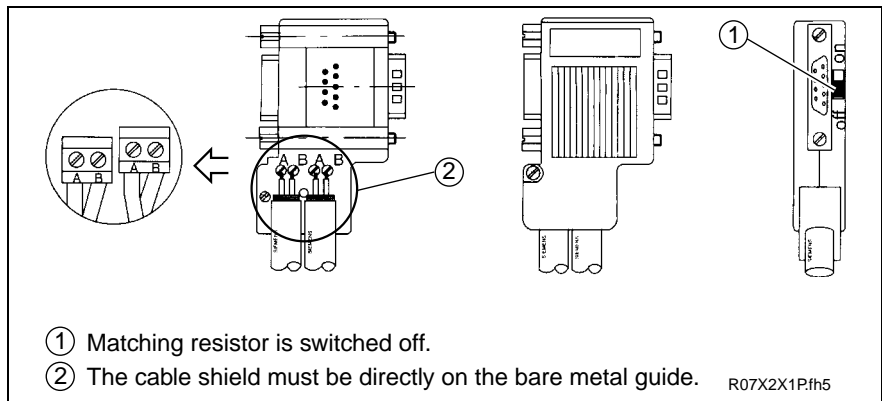

Fig. 22-6: Bus connection for all other slaves, bus connector INS0541 with 9-pin D-subminiature bushing

The DPF connection must implement a shielded two-core line as per DIN 19245, section 1.

Note:

23 Analog Signal Interface DRF01.1

23.1 General Information

Plug-in module DRF01.1 supports:

- the measurement of voltages via both differential inputs S1/S3 and S2/S4 for evaluation in the drive controller.

23.2 Terminal Diagram DRF01.1

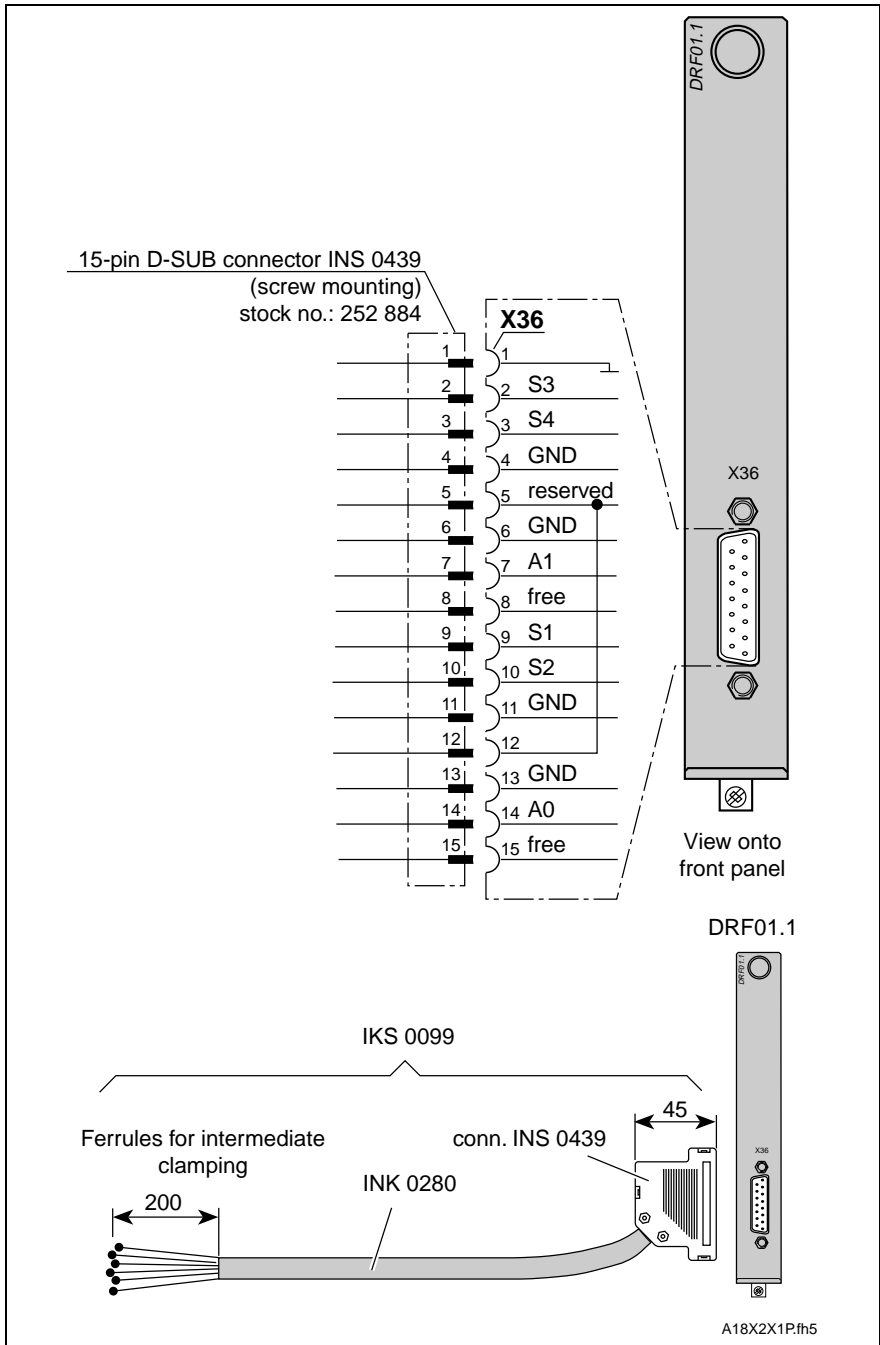

Fig. 23-1: Terminal Diagram DRF01.1

23.3 Technical data - DRF01.1

Schematic diagram - input channels S1/S3 and S2/S4

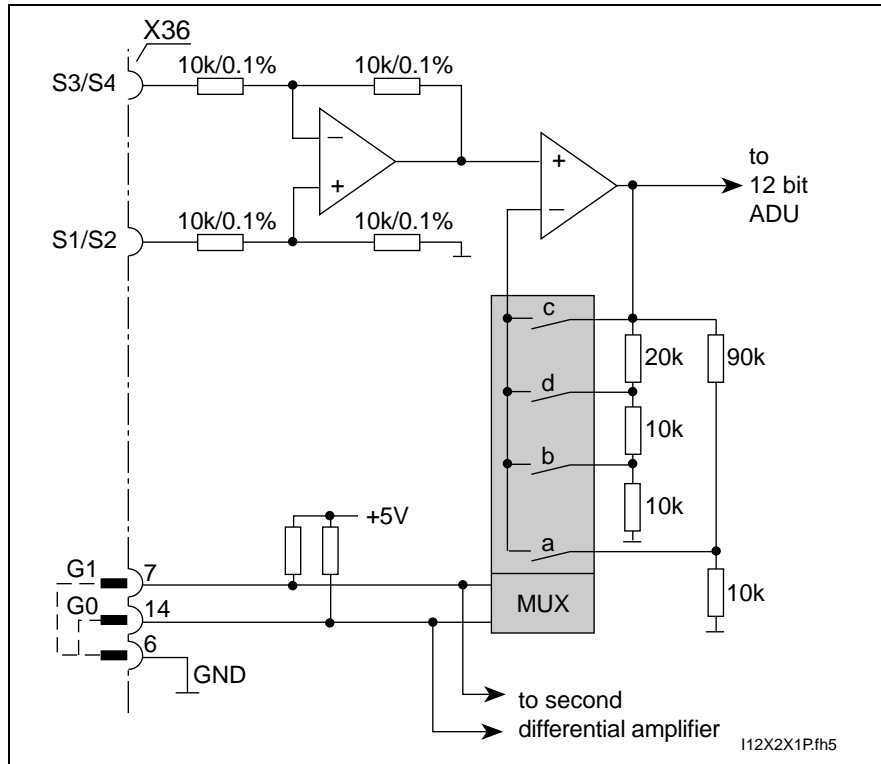

Fig. 23-2: Schematic diagram - input channels S1/S3 and S2/S4

Setting the amplification

Amplification is set by switching pins 7 and 14 with pin Pin 6 (GND). If pins 7 and 14 are open, then amplification is set to 2.

Switching connectors X36

Connector at		X36	MUX channel	Amplification
Pin 7	Pin 14			
free	free		d	2 (default)
free	GND		c	1
GND	free		b	4
GND	GND		a	10

Fig. 23-3: Switching connector X36

Voltage level and resolution of input signals

Amplification	Input voltage	min.	Resolution 12 bit	max.
1	S1, S2 S3, S4 S1-S3 S2-S4 Resolution	-10 V -10 V	4.88 mV/Bit	+10 V +10 V 10 V 10 V
2	S1, S2 S3, S4 S1-S3 S2-S4 Resolution	-5 V -5 V	2.44 mV/Bit	+5 V +5 V 5 V 5 V
4	S1, S2 S3, S4 S1-S3 S2-S4 Resolution	-2,5 V -2,5 V	1.22 mV/Bit	+2.5 V +2.5 V 2.5 V 2.5 V
10	S1, S2 S3, S4 S1-S3 S2-S4 Resolution	-1 V -1 V	0.49 mV/Bit	+1 V +1 V 1 V 1 V

Fig. 23-4: Voltage level and resolution of input signals

Maximum allowable voltage at the differential amplification inputs S1 to S4 equals $|\pm 50\text{ V}|$.

Note: Maximum allowable voltage at the differential amplification inputs S1 to S4 equals $\pm 50\text{V}$.

Note:

24 Summer Input Interface DSE01.1

24.1 General Information

The additional plug-in module "Summer input interface" DSE01.1 makes two summer inputs available in addition to the differential inputs for system configurations of digital AC servo drives with analog interface. These two summer inputs make it possible to add command values to the differential inputs at the ANALOG interface.

The drive enable signal is delayed via contacts ERF X40/9, ARF X40/11 (delay can be set), which is relayed to the command communications module used (DAE/DAA). Removing the drive enable via contact ERF X40/9, means that the differential input E1/E2 is switched off. The summer input remains active until the delayed drive enable removal is completed.

To enable NC control reactions suited to the process in the event of drive interference (e.g., return motions), error reaction 3 was introduced into the analog software for drive errors that permit the maintenance of the speed control loop.

How error reaction 3 works in the event of an error:

- 18 amplifier overtemperature shutdown
- 19 motor overtemperature shutdown
- 33 external power supply failure
- 68 braking error

The following error reaction is conducted:

- The drive fault is signalled to the NC control by opening the „Bb“ contact.
- The drive controller remains ready until the time-delayed drive enable signal removal is completed via summer input E3/E4.
- Differential inputs E1/E2 are switched off.
- Upon completion of the time delay, the AC servo drive goes torque free. Any optionally mounted holding brake is applied.

The digital AC servo drive with ANALOG interface with summer input interface DSE01.1 is thus functionally compatible with analog servo drives with TDM drive controllers.

Signal path and torque generation with removal of drive enable signal via the DSE01.1 contact ERF X40/8.

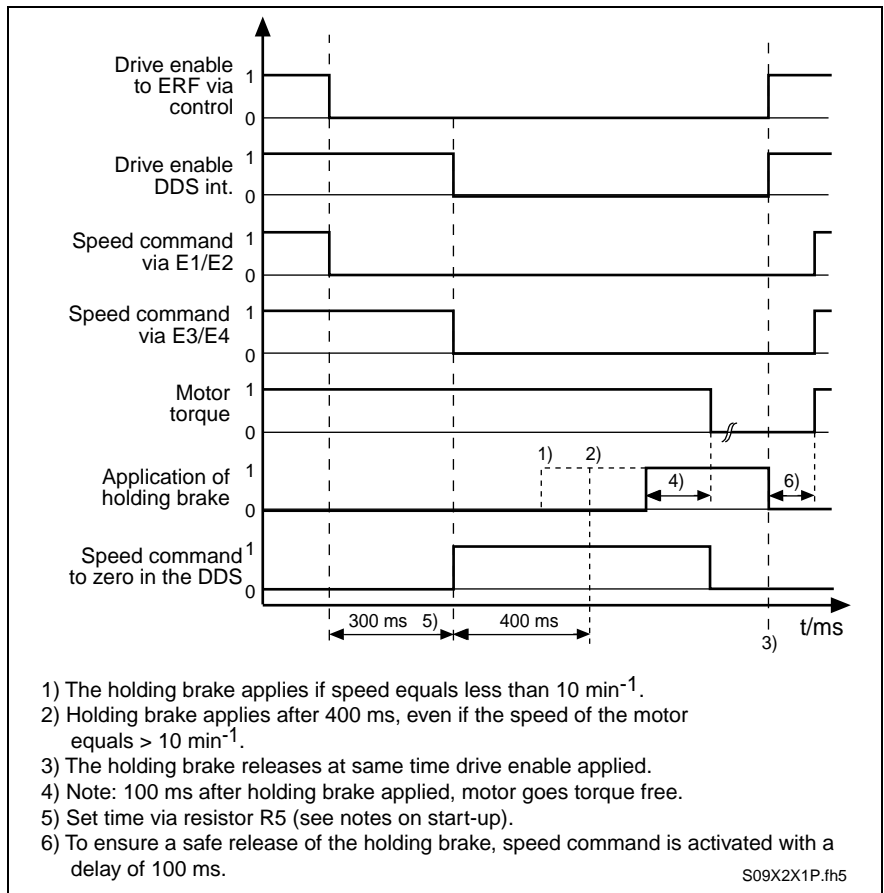

Fig.24-1: Signal path and torque generation as dependent on drive enable signal

24.2 Terminal Diagram

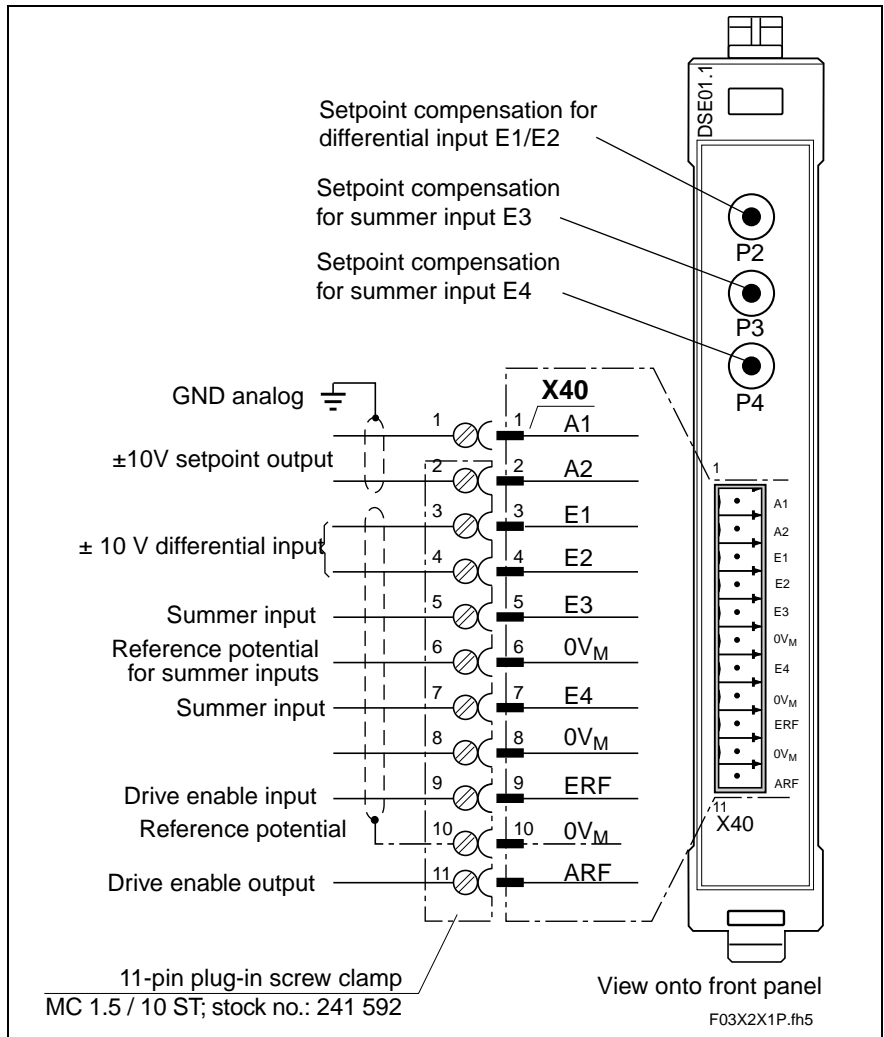

Fig. 24-2: Terminal diagram with allocation of terms to DSE01.1

24.3 Technical data - DSE01.1

Analog interface

Designation		Unit	min	max
Input voltage	E1	V	-10	+10
	E2	V	-10	+10
	E3/E4	V	-10	+10
	E1 - E2	V	-	10
	ERF _{HIGH}	V	+3	+30
Input current	E1	mA	-0.5	+0.5
	E2	mA	-0.5	+0.5
	E3/E4	mA	-1	+1
	ERF	mA		+2.5

Fig. 24-3: Technical data - analog input circuit

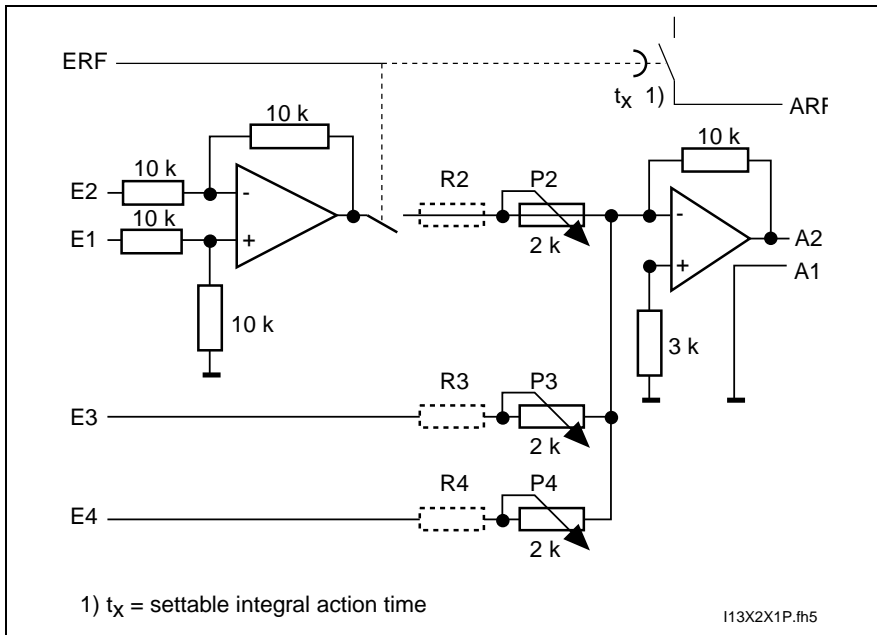

Fig. 24-4: Schematic diagram - analog input circuit

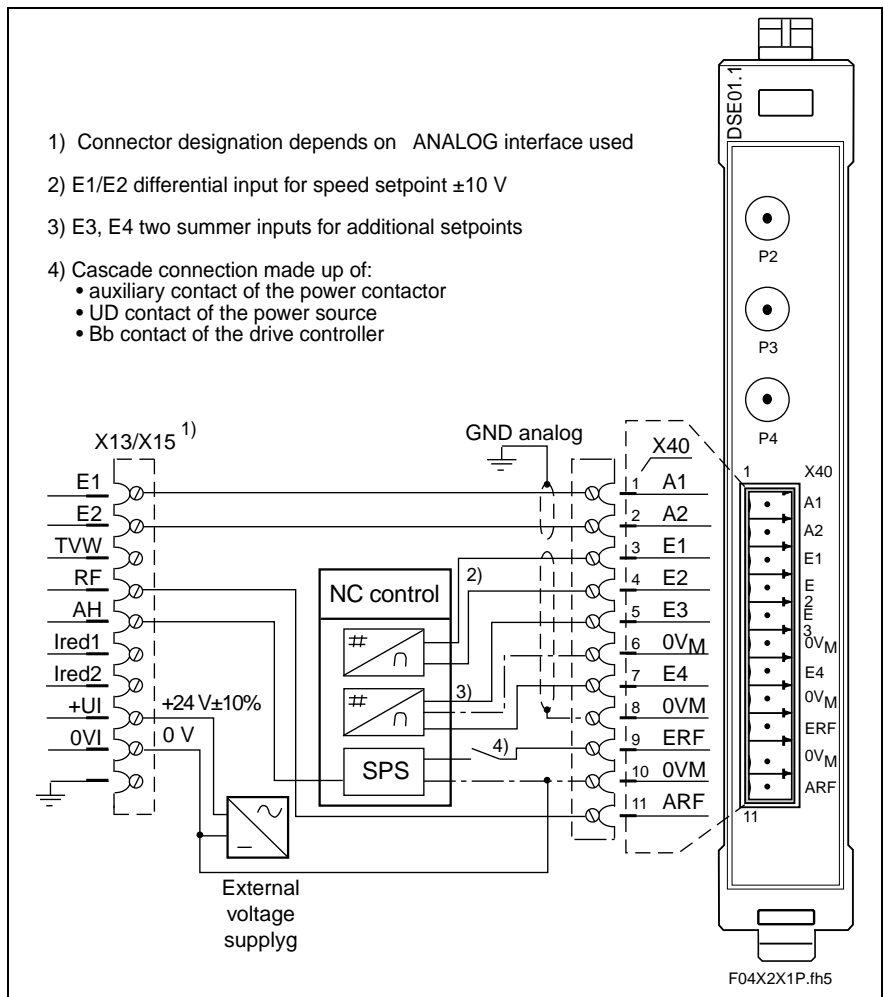

Fig. 24-5: Interconnection DSE01.1 with analog interface and NC control

24.4 Start-Ups

Step 1



DANGER

Danger can result from incorrect use of the digital AC servo drives!

When starting up digital AC servo drives, note the guidelines in "Application Description", doc. no. 209-0069-4315.

Additional instructions on starting up plug-in module DSE01.1 are outlined below.

Step 2

Speed command value - determining the evaluation via the resistors

- R2 for differential input E1/E2
- R3 for summer input E3
- R4 for summer input E4

It applies:

$$R_x = \frac{10k \times U_E}{10V} - 1k$$

R_x: resistance to speed command value evaluation of relevant inputs
 U_E: rapid input voltage

Fig. 24-6: Determining resistance to speed command value evaluation

- Solder resistors into place, use a maximum tolerance of 1%.

Step 3

Off delay - setting the drive enable signal



DANGER

Danger to AC servo motors and drive controllers from overtemperature!

⇒ Set off delay to a maximum of ≤ 1 seconds.

Note: The OFF delay is standardly set in the TDM to 300ms.

If, for process-compatible actions (e.g., return motions), an OFF delay up to the deactivation of the speed command values via summer inputs E3/E4 is needed, then this can be set via resistor R5. To determine the resistance, see .

To set an OFF delay other than 300 ms, proceed as follows:

1. find resistance listed in Fig. 24-7
2. solder resistance in at soldering point R5

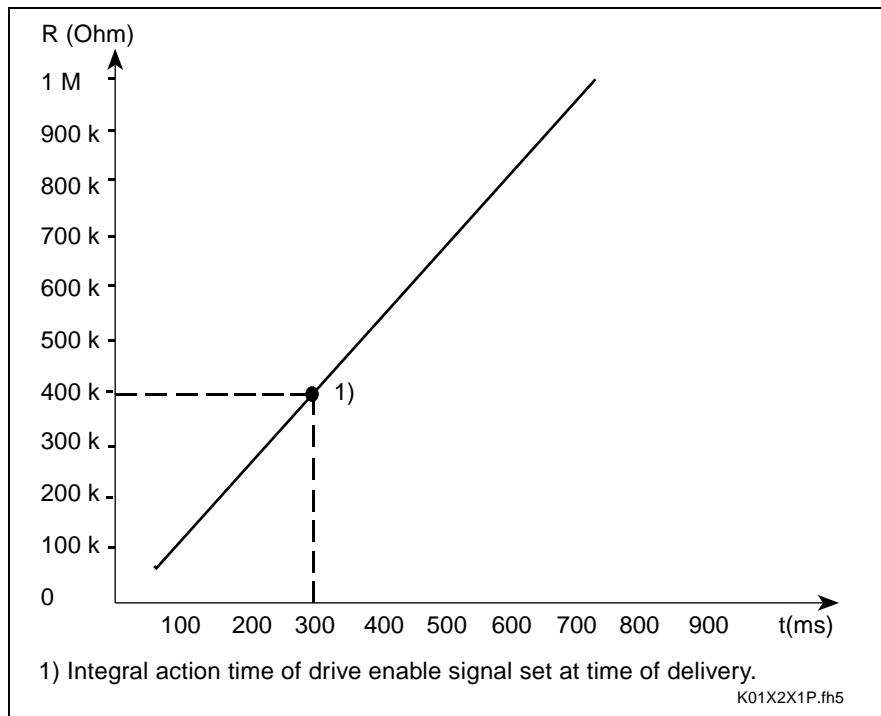

Fig. 24-7: Setting resistor R5 to the OFF delay drive enable signal

Step 4 Insert additional plug-in modules in available slot in drive controller.

Note: Set drive enable in series with „Bb“ contact X3.6/7.

Step 5 Connect DSE card per Fig. 24-5.

Step 6 In menu „Mode/scaling“ of the user interface, set the following parameters:

- „command default for speed“ to 10 V
- set „speed with command value default“ to rapid traverse speed
- set error reaction 3

Step 7



DANGER

Danger of accidents due to unwanted drive motions.

⇒ Switch power supply off before compensating voltage.

Apply rapid traverse voltage at relevant input and compensate via the relevant potentiometer to 10 V at X40/A1-A2.

P2 = differential input E1/E2

P3 = summer input E3

P4 = summer input E4

Step 8 Drift compensation of servo axis (see Application Description, sec. 8.2.).

Step 9 Now note the instructions in the Application Description.

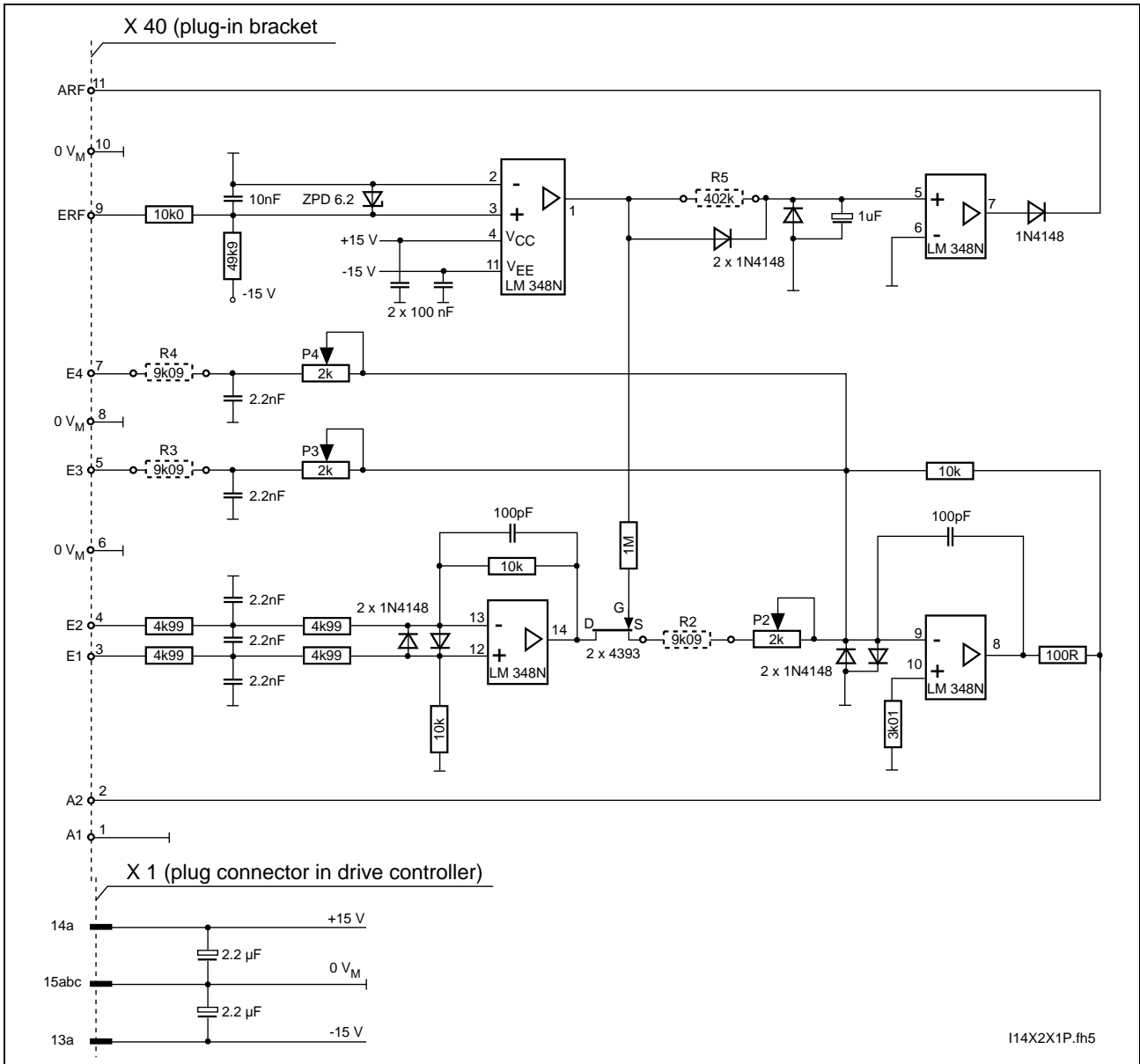

Fig. 24-8: Current path of the summer input interfaces DSE01.1

25 SERCOS interface DSS01.1

25.1 General Information

The plug-in module "SERCOS interface DSS01.1" makes it possible to operate digital drives with SERCOS interface compatible NC control units via fiber optic cables. It also offers inputs for the evaluation of reference switches, travel range limit switches and probes.

25.2 Terminal Diagram

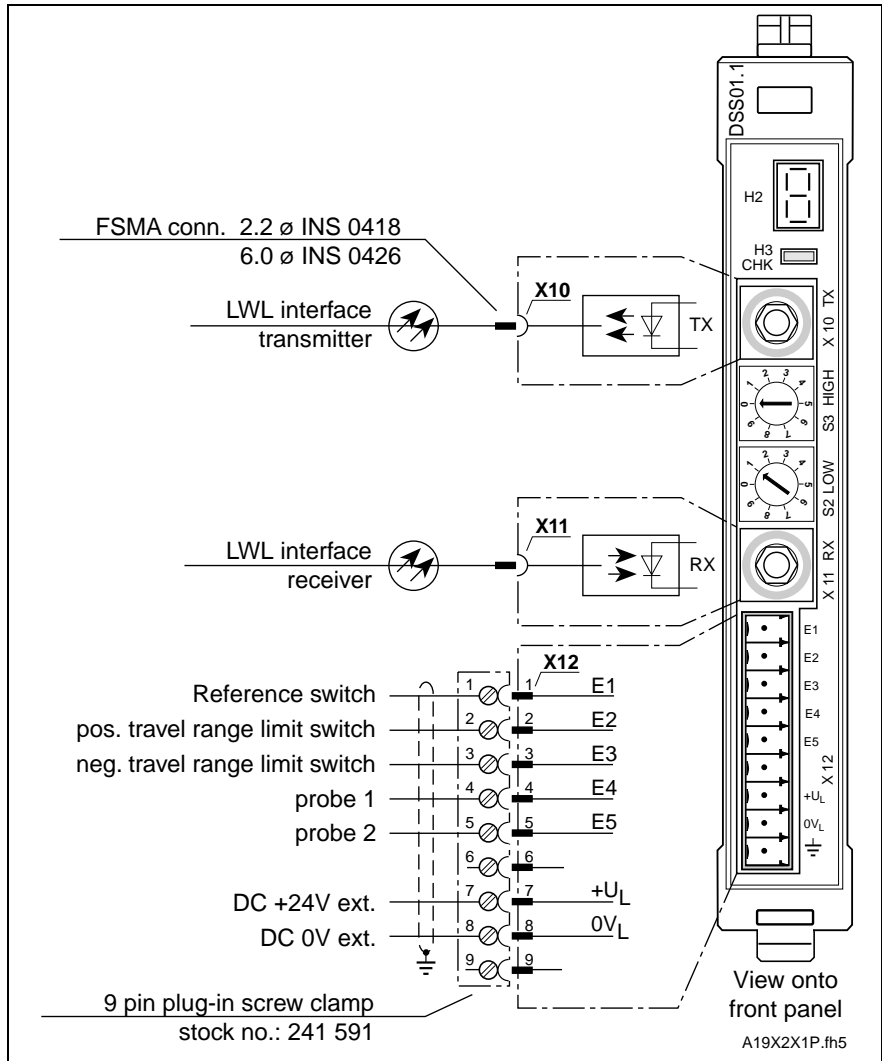

Fig. 25-1: Terminal Diagram DSS01.1

25.3 Technical data - DSS01.1

Voltage level DSS01.1

Designation	Unit	min	type/ value	max
External voltage supply +U _L	V	18	24	32
Current consumption- +U _L	mA			100
Inputs E1...E6	U _{High}	V	16	24
	U _{Low}	V	0	5.5

Fig. 25-2: Voltage level DSS01.1

Schematic diagram of digital input circuits

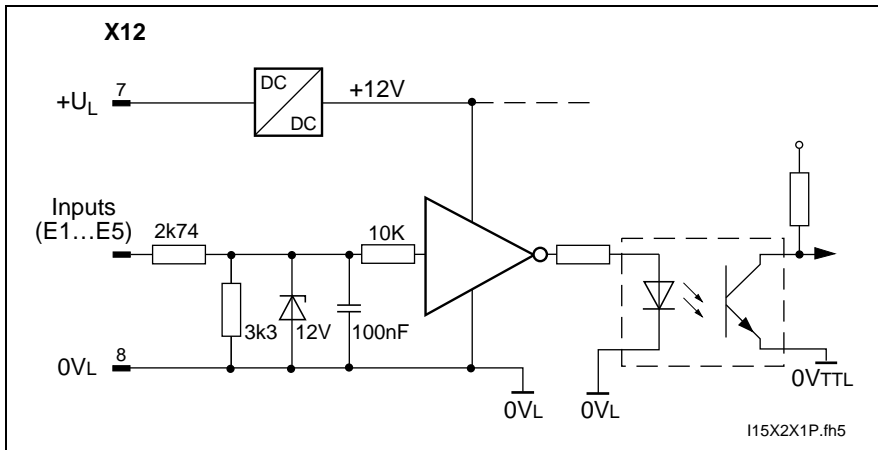

Fig. 25-3: Schematic diagram of digital input circuits

	Name	Abbreviation	Unit	min. 1)	max. 1)
Transmitter data Tx	max. transmission power with opt. low level	P _{SmaxL}	dBm/μW	-31.2/0.75	-28.2/1.5
	min. transmission power with opt. high level	P _{SminH}	dBm/μW	-10.5/90	-7.5/180
	max. transmission power with opt. high level	P _{SmaxH}	dBm/μW	-5.5/280	-3.5/450
	wave length transmission diode: peak wave length spectral bandwidth	λ _p λ _p	nm nm	640...675 nm (0° to 55° C) ≤ 30 nm (25° C)	
Receiver-data Rx	max. input power for opt. low level	P _{EmaxL}	dBm/μW	-31.2/0.75	
	min. input power for opt. high level	P _{EminH}	dBm/μW	-20/10	
	max. input power for opt. high level	P _{EmaxH}	dBm/μW	-5/320	
	max. attenuation of transmission path	P _{SminH} ...P _{EminH}	dB	9.5	12.5

1) Transmission power is set to maximum at delivery. Transmission power can be switched using switch S1.1 on the SERCOS module board, if necessary.

Fig. 25-4: Technical data - fiber optic cable interface

26 SERCOS interface DSS01.3

26.1 General Information

Plug-in module "SERCOS interface DSS01.3" enables the operation of digital drives with SERCOS interface compatible controls via fiber optic cables. It also offers inputs for the evaluation of reference switches, travel range limit switches, probes and an emergency stop input.

26.2 Terminal Diagram

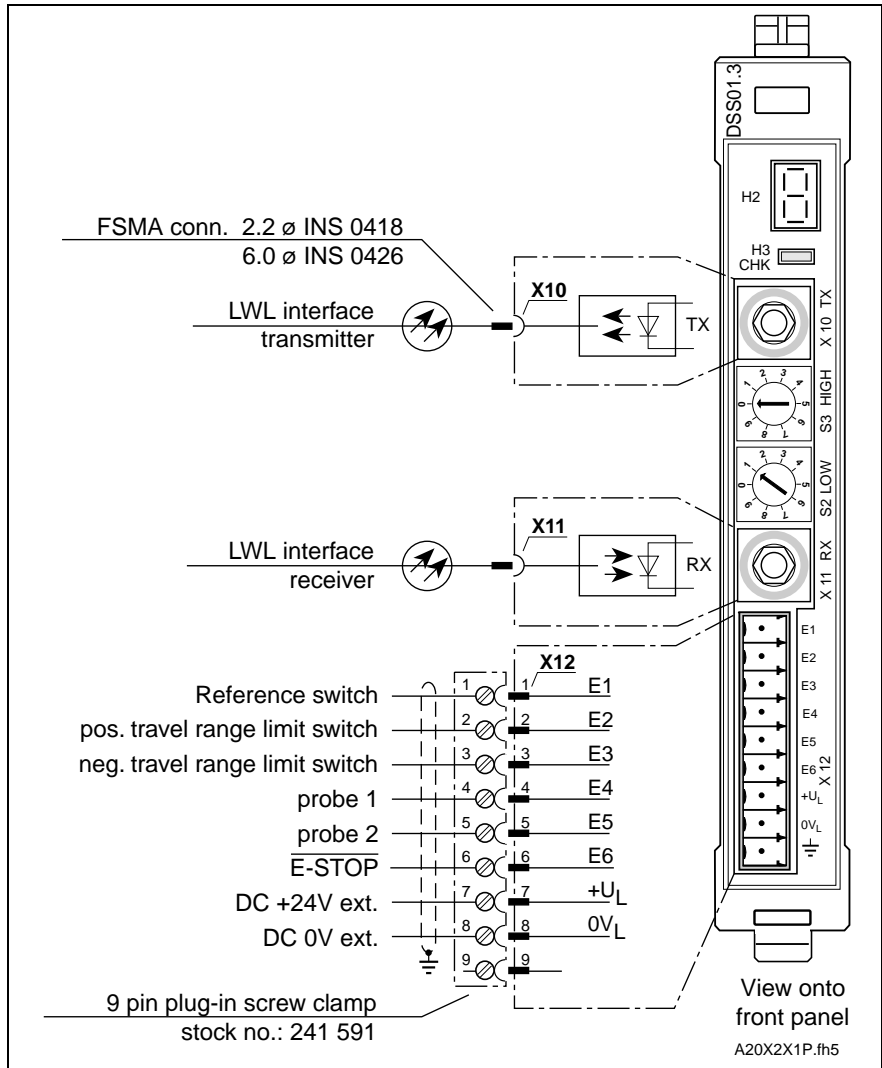

Fig. 26-1: Terminal Diagram DSS01.3

26.3 Technical data - DSS01.3

Voltage level DSS01.3

Designation	Unit	min	type/ value	max
External voltage supply +U _L	V	18	24	32
Current consumption- +U _L	mA			100
Inputs E1...E6	U _{High}	V	17	24
	U _{Low}	V	0	5.5

Fig. 26-2: Voltage level DSS01.3

Schematic diagram of digital input circuits

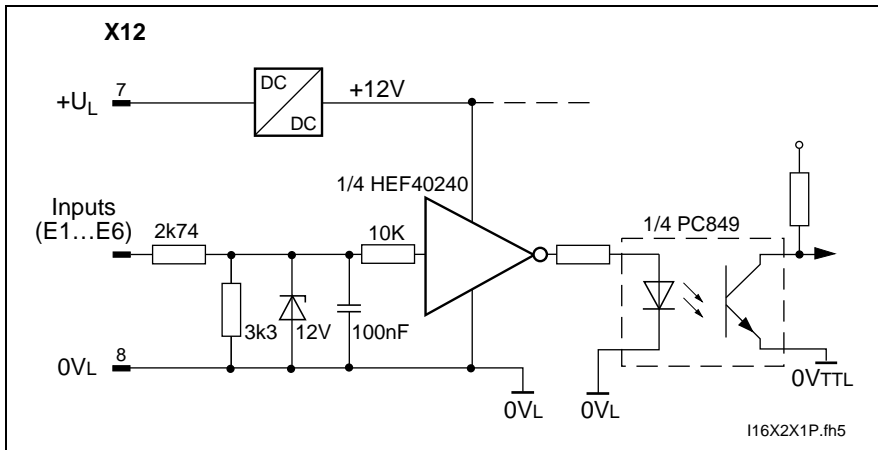

Fig. 26-3: Schematic diagram of digital input circuits

	Name	Abbreviation	Unit	min. 1)	max. 1)
Transmitter data Tx	max. transmission power with opt. low level	P _{SmaxL}	dBm/μW	-31.2/0.75	-28.2/1.5
	min. transmission power with opt. high level	P _{SminH}	dBm/μW	-10.5/90	-7.5/180
	max. transmission power with opt. high level	P _{SmaxH}	dBm/μW	-5.5/280	-3.5/450
	wavelength of transmission diode: peak wavelength spectral bandwidth	λ _p λ _p	nm nm	640...675 nm (0° to 55° C) ≤ 30 nm (25° C)	
Receiver-data Rx	max. input power for opt. low level	P _{EmaxL}	dBm/μW	-31.2/0.75	
	min. input power for opt. high level	P _{EminH}	dBm/μW	-20/10	
	max. input power for opt. high level	P _{EmaxH}	dBm/μW	-5/320	
	max. attenuation transmission path	P _{SminH} ...P _{EminH}	dB	9.5	12.5

1) Transmission power is set to maximum at delivery. Transmission power can be switched using switch S1.1 on the SERCOS module board, if necessary.

Fig. 26-4: Technical data - fiber optic cable interface

27 Gear Encoder Interface DZF01.1

27.1 General Information

Plug-in module "Gear Encoder Interface" supports the evaluation of a high-resolution main spindle position encoder.

27.2 Terminal Diagram

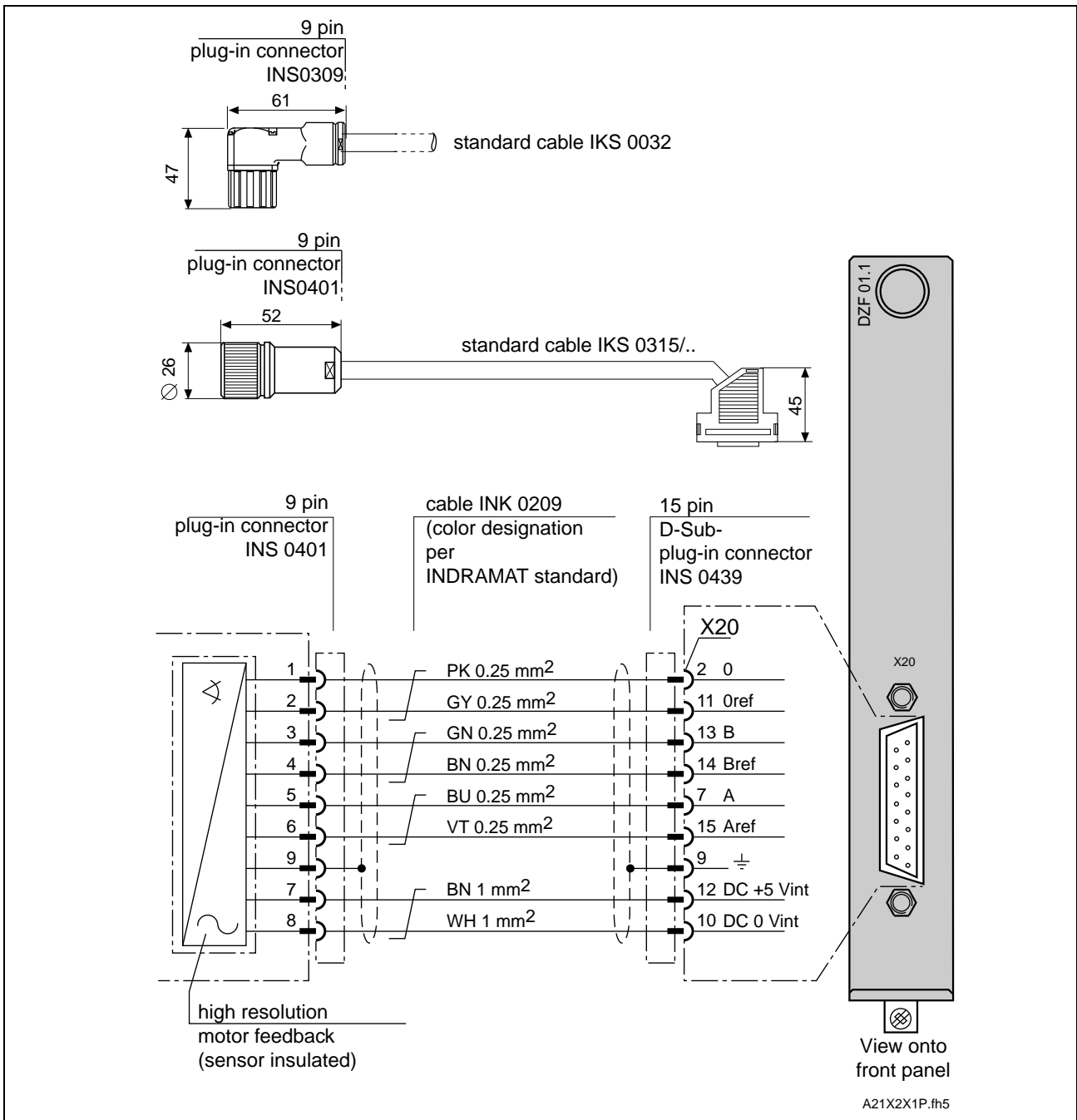

Fig. 27-1: Terminal Diagram DZF01.1



WARNING

⇒ The cable to the high-resolution motor feedback should not be routed over a terminal strip because of its sensitivity to interference!

27.3 Power supply of the external measuring system

Designation	Unit	min.	type/ value	max.
Output voltage +5 V	V	3	5	5.25
Output current - +5 V	mA			200

Fig. 27-2: Power supply of the external measuring system

28 Gear Encoder Interface DZF02.1

28.1 General Information

Plug-in module "Gear Encoder Interface" supports the evaluation of a high-resolution main spindle position encoder (type SH2 / MH2) and the feedback of 2AD / ADF motors with feedback type "3".

28.2 Terminal Diagram

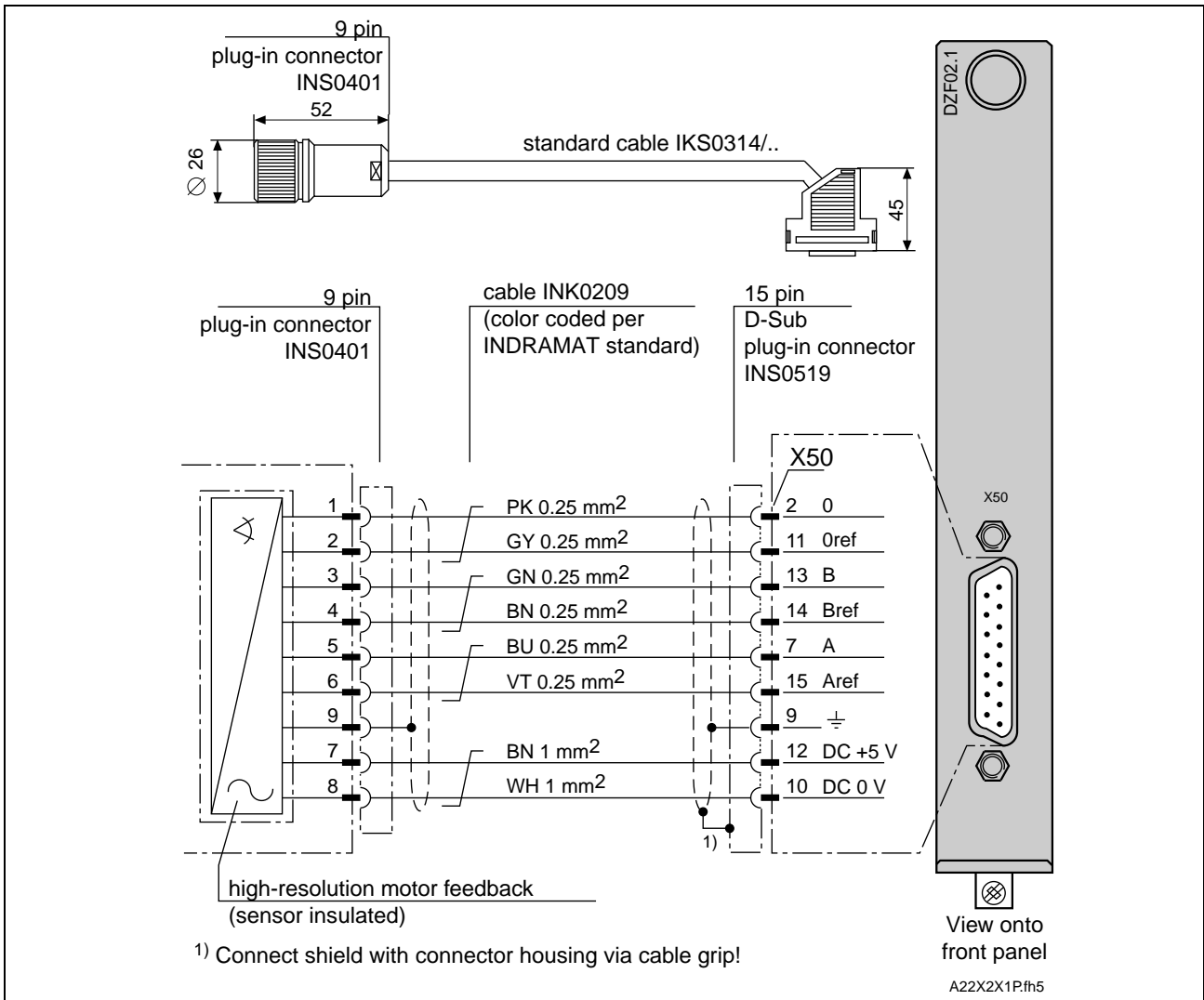

Fig. 28-1: Terminal Diagram DZF02.1



WARNING

⇒ **The cable to the high-resolution motor feedback should not be routed over a terminal strip because of its sensitivity to interference!**

28.3 Power supply of the external measuring system

Designation	Unit	min.	type/ value	max.
Output voltage +5 V	V	3	5	5.25
Output current - +5 V	mA			200

Fig. 28-2: Power supply of the external measuring system

29 Plug-In Module Accessories

29.1 Encoder Branching DGA01.2 for encoders with sinusoidal $1V_{SS}$ voltage signals

General Information

With a DGA it is possible to distribute the signals of a measuring system to up to four measuring systems inputs of different drive controllers. Possible applications of a DGA are:

- parallel switching of linear motors using one measuring system
- discharge of position signals to external NC controls for monitoring purposes or as a master axis position.

All measuring systems with sinusoidal output signals and a signal level of $1V_{SS}$ can be connected (Heidenhain voltage interface).

Up to four drive controllers can be operated with one DGA. It also has an output with square signals.

DGA01.2 - schematics of the connections

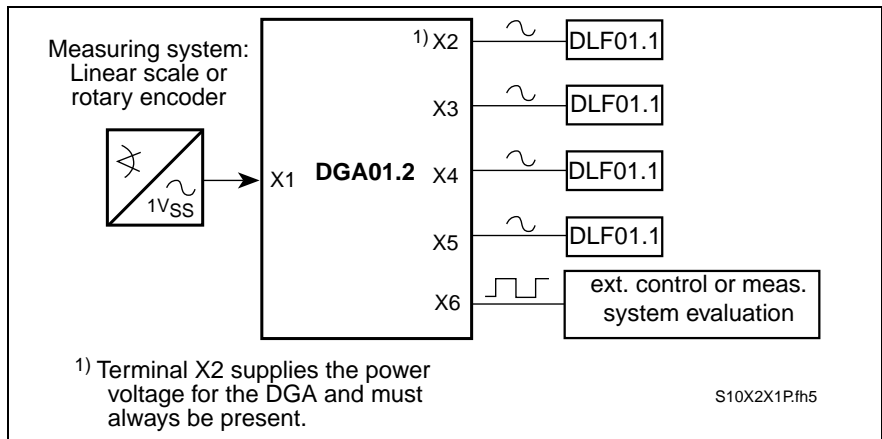

Fig. 29-1: Schematics of the connections DGA01.2

Standard cables

Connections	Standard cable
of DGA01.2 (X2, X3, X4, X5) to DLF01.1	IKS0131
of DGA01.2 (X6) to DEF01.1	IKS0331

Fig. 29-2: Standard cables

Terminal Diagram

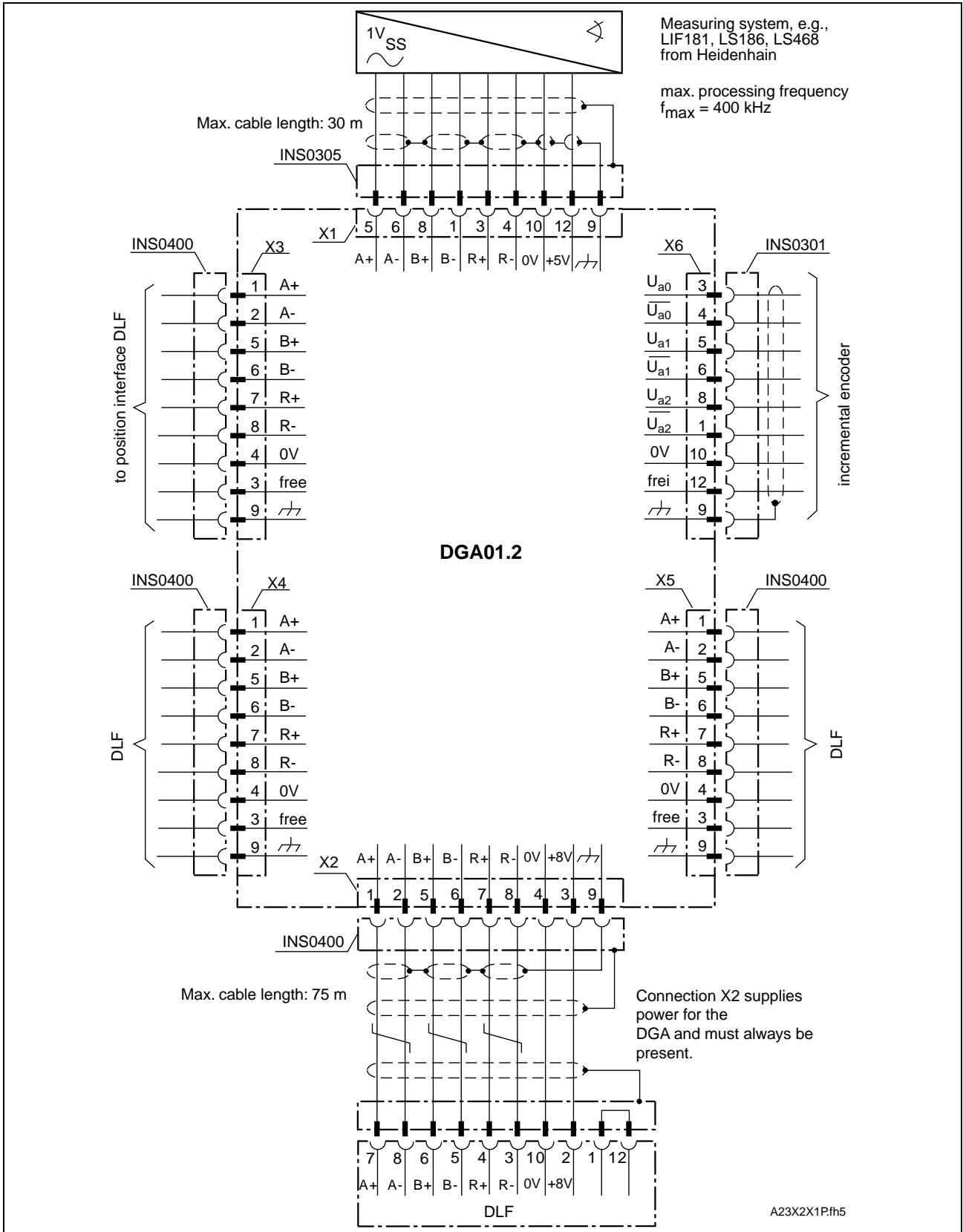

Fig. 29-3: Terminal Diagram DGA01.2

Dimensional sheet - DGA01.2

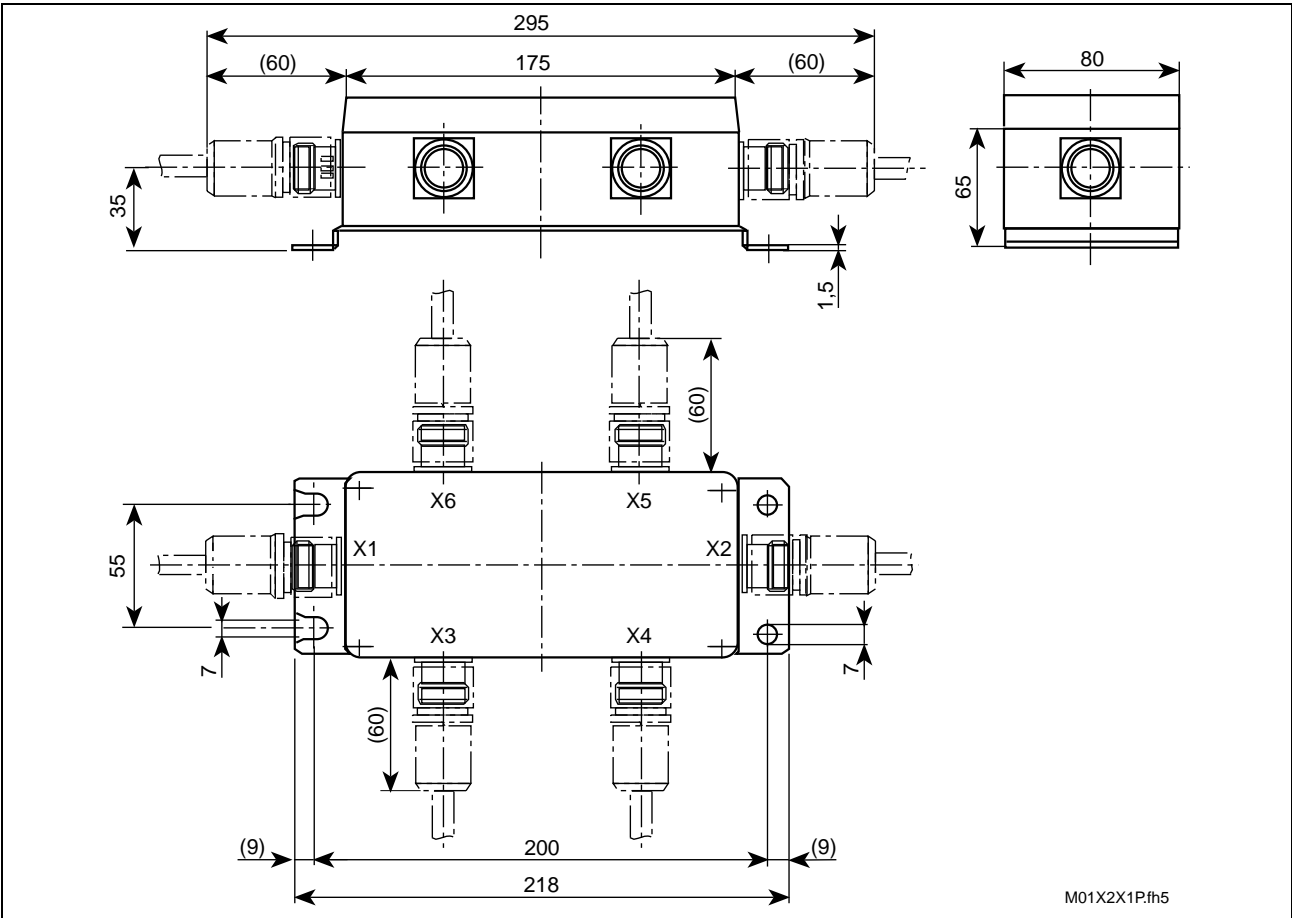

Fig. 29-4: Dimensional sheet - DGA01.2

Technical Data

	External measuring system	
Power supply for external measuring system	Output voltage X1/12:	DC +5 V ($\pm 5\%$)
	Maximum output load X1/12:	150 mA
Signal form	Approximate sinusoidal signals	
Voltage signals	Signal voltage:	A, B, R 1 V_{SS}
	Max. frequency of meas. sys. signals:	A, B 400 kHz
	Max. frequency of reference signal:	R 15 kHz

Signal input circuits

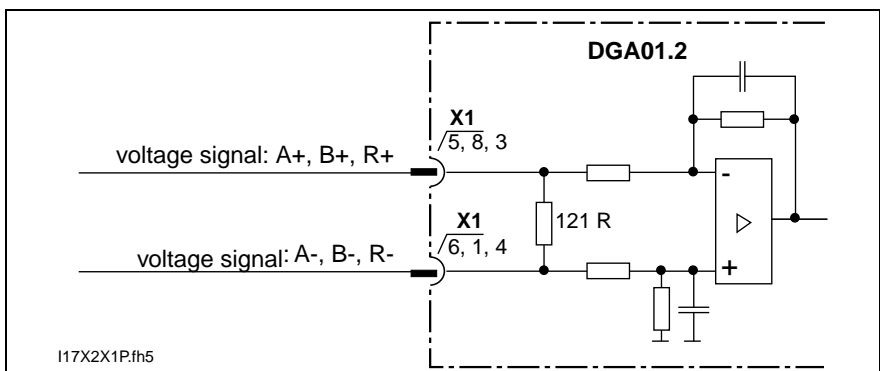

Fig. 29-5: Signal input circuits

Schematic diagram - signal paths

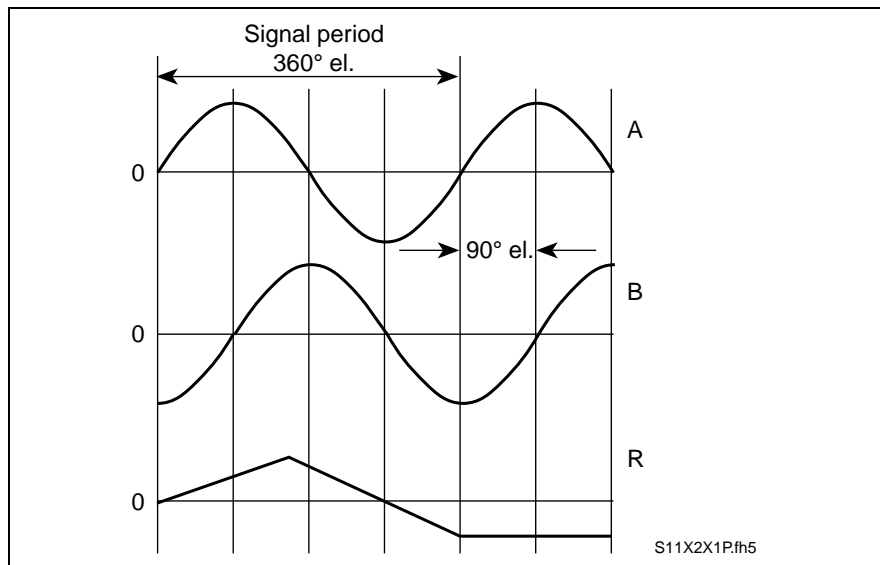

Fig. 29-6: Schematic diagram - signal paths

Branching - measuring system signals to four terminals

The signals from the measuring system are branched to four terminals, namely, X2, X3, X4 and X5.

Power supply - DGA01.2

The DGA01.2 receives its power via terminal X2.

Connected voltage X2/3: DC +8 V (±5%)

Maximum current consumption: 300 mA

Recommended signal input circuit

See Fig. 29-5

Output of measuring system signals as square-wave signals

The sinusoidal signals of the measuring systems are output via terminal X6 in the form of square-wave incremental signals.

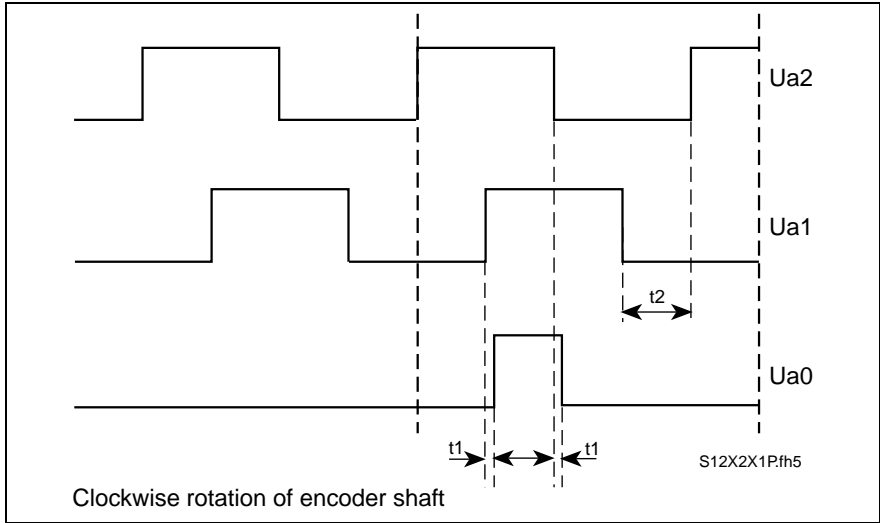

Fig. 29-7: Voltage level and phase angle of the incremental signals

Designation	Unit	min.	type/value	max.
Phase angle Ua1	Grad		0	
Phase angle Ua2	Grad		90	
Signal amplitude Ua-/(Ua)	V _{SS}		7	
Reference point delay t1	ns			50
Edge distance t2	ns	500		

Fig. 29-8: Daten zu den Inkrementalsignalen

Output circuit

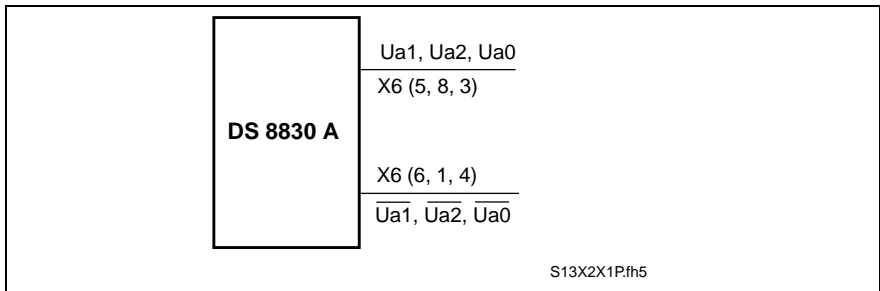

Fig. 29-9: Output circuit

Recommended input circuits

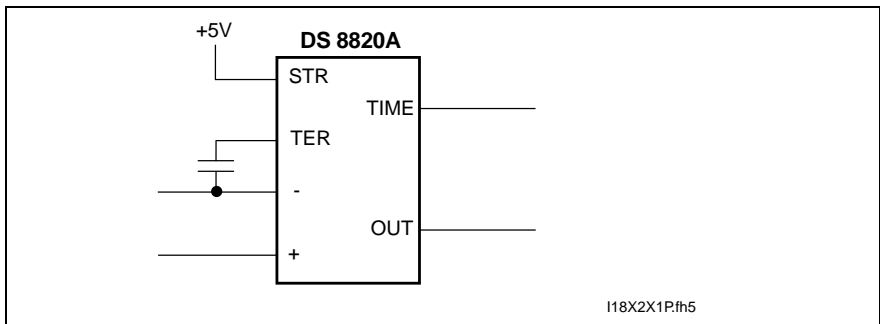

Fig. 29-10: Recommended input circuits

29.2 Line Driver DGV01.1 for Measuring Systems with Current Signals

Terminal Diagram - Line driver DGV01.1

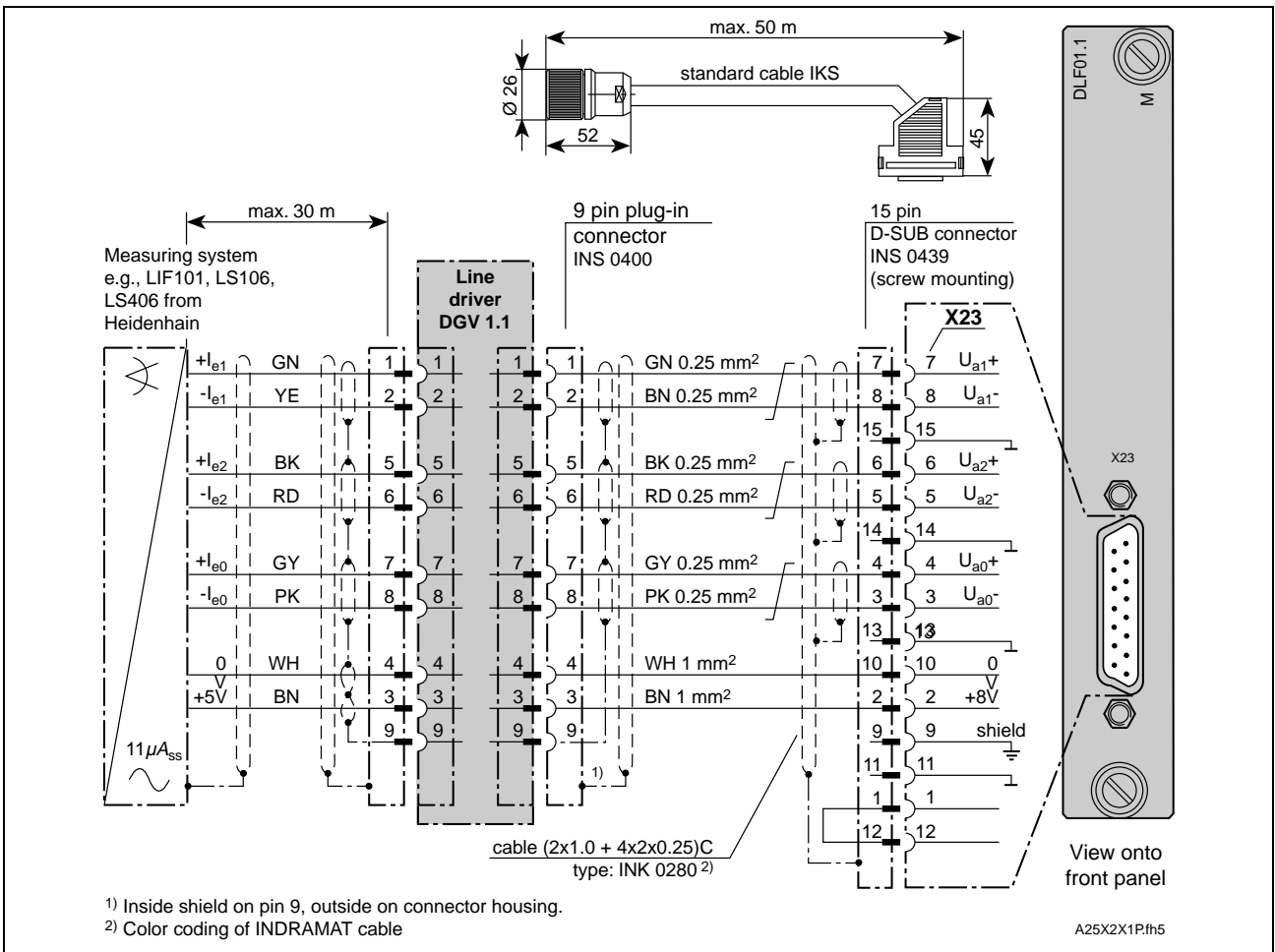

Fig. 29-11: Terminal diagram - Line driver DGV01.1

Dimensional sheet - Line driver DGV01.1

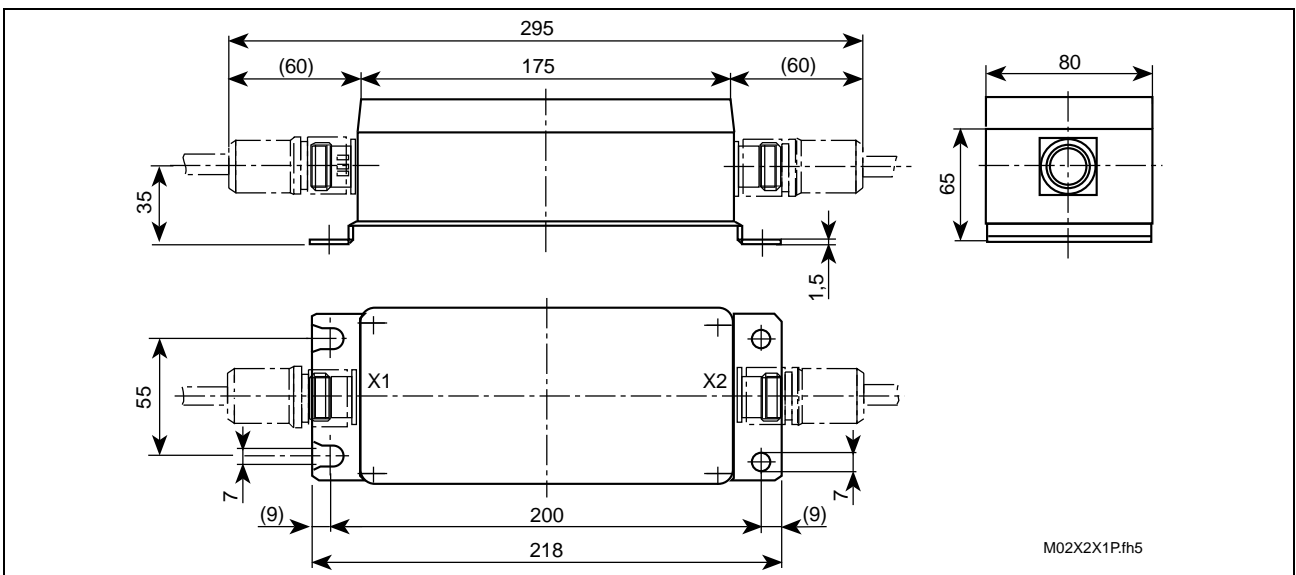

Fig. 29-12: Dimensional sheet - Line driver DGV01.1

30 Index

A

ANALOG interface 7-1
 Analog Signal Interface 23-1
 ARCNET Coupler Card 9-1
 Areas of Use 1-1

C

CLC-D01.1A-FW 5-1
 CLC-D02.1A-FW 6-1
 CLC-D02.3A-FW 6-1
 Control Card 5-1

D

DAA01.1 7-1
 DAE01.1 8-1
 DAK01.1A 9-1
 DBS02.1-FW 10-1
 DBS02.2-FW 11-1
 DBS03.1-FW 12-1
 DEA04.1, DEA05.1, DEA06.1 13-1
 DEA04.2, DEA05.2, DEA06.2 14-1
 DEA28.1, DEA29.1, DEA30.1 15-1
 DEF01.1 and DEF02.1 16-1
 DFF01.1 17-1
 DGA01.2 29-1
 DGV01.1 29-6
 DLC01.1 18-1
 DLC02.1-FW 19-1
 DLF 01.1 20-1
 DPF02.1/03.1/04.1 21-1
 DPF05.1-FW 22-1
 DRF01.1 23-1
 DSE01.1 24-1
 DSS01.1 25-1
 DSS01.3 26-1
 DZF01.1 27-1
 DZF02.1 28-1

E

Earth-Fault Monitoring 4-2
 Encoder Branching 29-1
 Encoder Interface 17-1

G

Gear Encoder Interface 27-1
 Ground Reference 4-1

H

High-Resolution Position Interface for
 Sine Signals 20-1
 Humidity 2-1

I

Input / output interface 13-1
 INTERBUS-S interface module 10-1
 INTERBUS-S Slave Module 12-1

L

Line driver 29-6
 Low-voltage loops 4-1

M

Metal front plates 3-1

O

Optocoupler Interface 4-1

P

Plastic 3-1
 Plug-In Module Accessories 29-1
 Position Interface for Square-Wave
 Signals 16-1
 Positioning Module 18-1
 Profibus Interface 21-1

S

SERCOS interface 25-1
 Signal inputs 4-1
 Signal outputs 4-1
 Storage 2-1

T

Temperature 2-1
 Transport Conditions 2-1
 Type code 3-2

Directory of Customer Service Locations

Germany

<p>Sales region central</p> <p>INDRAMAT GmbH D-97816 Lohr am Main Bgm.-Dr.-Nebel-Str. 2 Telefon: 09352/40-0 Telefax: 09352/40-4885</p>	<p>Sales region east</p> <p>INDRAMAT GmbH D-09120 Chemnitz Beckerstraße 31 Telefon: 0371/3555-0 Telefax: 0371/3555-230</p>	<p>Sales region west</p> <p>INDRAMAT GmbH D-40849 Ratingen Hansastraße 25 Telefon: 02102/4318-0 Telefax: 02102/41315</p>	<p>Sales region north</p> <p>INDRAMAT GmbH D-22085 Hamburg Fährhausstraße 11 Telefon: 040/227126-16 Telefax: 040/227126-15</p>
<p>Sales region south</p> <p>INDRAMAT GmbH D-80339 München Ridlerstraße 75 Telefon: 089/540138-30 Telefax: 089/540138-10</p>	<p>Sales region southwest</p> <p>INDRAMAT GmbH D-71229 Leonberg Böblinger Straße 25 Telefon: 07152/972-6 Telefax: 07152/972-727</p>		<p>INDRAMAT Service-Hotline</p> <p>INDRAMAT GmbH Telefon: D-0172/660 040 6 -or- Telefon: D-0171/333 882 6</p>

Customer Service locations in Germany

Europe

<p>Austria</p> <p>G.L.Rexroth Ges.m.b.H. Geschäftsbereich INDRAMAT A-1140 Wien Hägelingasse 3 Telefon: 1/9852540-400 Telefax: 1/9852540-93</p>	<p>Austria</p> <p>G.L.Rexroth Ges.m.b.H. Geschäftsbereich INDRAMAT A-4061 Pasching Randlstraße 14 Telefon: 07229/4401-36 Telefax: 07229/4401-80</p>	<p>Belgium</p> <p>Mannesmann Rexroth N.V.-S.A. Geschäftsbereich INDRAMAT B-1740 Ternat Industrielaan 8 Telefon: 02/5823180 Telefax: 02/5824310</p>	<p>Denmark</p> <p>BEC Elektronik AS DK-8900 Randers Zinkvej 6 Telefon: 086/447866 Telefax: 086/447160</p>
<p>England</p> <p>Mannesmann Rexroth Ltd. INDRAMAT Division Cirencester, Glos GL7 1YG 4 Esland Place, Love Lane Telefon: 01285/658671 Telefax: 01285/654991</p>	<p>Finnland</p> <p>Rexroth Mecman OY SF-01720 Vantaa Riihimiehentie 3 Telefon: 0/848511 Telefax: 0/846387</p>	<p>France</p> <p>Rexroth - Sigma S.A. Division INDRAMAT F-92632 Gennevilliers Cedex Parc of the Barbanniers 4, Place du Village Telefon: 1/41475430 Telefax: 1/47946941</p>	<p>France</p> <p>Rexroth - Sigma S.A. Division INDRAMAT F-69634 Venissieux - Cx 91, Bd 1 Joliot Curie Telefon: 78785256 Telefax: 78785231</p>
<p>France</p> <p>Rexroth - Sigma S.A. Division INDRAMAT F-31100 Toulouse 270, Avenue de l'ardenne Telefon: 61499519 Telefax: 61310041</p>	<p>Italy</p> <p>Rexroth S.p.A. Divisione INDRAMAT I-20063 Cernusco S/N.MI Via G. Di Vittoria, 1 Telefon: 02/92365-270 Telefax: 02/92108069</p>	<p>Italy</p> <p>Rexroth S.p.A. Divisione INDRAMAT Via Borgomanero, 11 I-10145 Torino Telefon: 011/7712230 Telefax: 011/7710190</p>	<p>Netherlands</p> <p>Hydraudyne Hydrauliek B.V. Kruisbroeksestraat 1a P.O. Box 32 NL-5280 AA Boxtel Telefon: 04116/51951 Telefax: 04116/51483</p>
<p>Spain</p> <p>Rexroth S.A. Centro Industrial Santiago Obradors s/n E-08130 Santa Perpetua de Mogoda (Barcelona) Telefon: 03/718 68 51 Telex: 591 81 Telefax: 03/718 98 62</p>	<p>Spain</p> <p>Goimendi S.A. División Indramat Jolastokieta (Herrera) Apartado 11 37 San Sebastian, 20017 Telefon: 043/40 01 63 Telex: 361 72 Telefax: 043/39 93 95</p>	<p>Sweden</p> <p>AB Rexroth Mecman INDRAMAT Division Varuvägen 7 S-125 81 Stockholm Telefon: 08/727 92 00 Telefax: 08/64 73 277</p>	<p>Switzerland</p> <p>Rexroth SA Département INDRAMAT Chemin de l'Ecole 6 CH-1036 Sullens Telefon: 021/731 43 77 Telefax: 021/731 46 78</p>
<p>Switzerland</p> <p>Rexroth AG Geschäftsbereich INDRAMAT Gewerbstraße 3 CH-8500 Frauenfeld Telefon: 052/720 21 00 Telefax: 052/720 21 11</p>	<p>Russia</p> <p>Tschudnenko E.B. Arsenia 22 153000 Ivanovo Rußland Telefon: 093/22 39 633</p>		

European customer service locations without Germany

Outside of Europe

<p>Argentina</p> <p>Mannesmann Rexroth S.A.I.C. Division INDRAMAT Acassusso 48 41/7 1605 Munro (Buenos Aires) Argentina Telefon: 01/756 01 40 01/756 02 40 Telex: 262 66 rexro ar Telefax: 01/756 01 36</p>	<p>Argentina</p> <p>Nakase Asesoramiento Tecnico Diaz Velez 2929 1636 Olivos (Provincia de Buenos Aires) Argentina Argentina Telefon 01/790 52 30</p>	<p>Australia</p> <p>Australian Industrial Machinery Services Pty. Ltd. Unit 3/45 Horne ST Campbellfield VIC 2061 Australia Telefon: 03/93 59 0228 Telefax: 03/93 59 02886</p>	<p>Brazil</p> <p>Mannesmann Rexroth Automação Ltda. Divisão INDRAMAT Rua Georg Rexroth, 609 Vila Padre Anchieta BR-09.951-250 Diadema-SP Caixa Postal 377 BR-09.901-970 Diadema-SP Telefon: 011/745 90 65 011/745 90 70 Telefax: 011/745 90 50</p>
<p>Canada</p> <p>Basic Technologies Corporation Burlington Division 3426 Mainway Drive Burlington, Ontario Canada L7M 1A8 Telefon: 905/335-55 11 Telefax: 905/335-41 84</p>	<p>China</p> <p>Rexroth (China) Ltd. Shanghai Office Room 206 Shanghai Intern. Trade Centre 2200 Yanan Xi Lu Shanghai 200335 P.R. China Telefon: 021/627 55 333 Telefax: 021/627 55 666</p>	<p>China</p> <p>Rexroth (China) Ltd. Shanghai Parts & Service Centre 199 Wu Cao Road, Hua Cao Minhang District Shanghai 201 103 P.R. China Telefon: 021/622 00 058 Telefax: 021/622 00 068</p>	<p>China</p> <p>Rexroth (China) Ltd. 1430 China World Trade Centre 1, Jianguomenwai Avenue Beijing 100004 P.R. China Telefon: 010/50 50 380 Telefax: 010/50 50 379</p>
<p>China</p> <p>Rexroth (China) Ltd. A-5F., 123 Lian Shan Street Sha He Kou District Dalian 116 023 P.R. China Telefon: 0411/46 78 930 Telefax: 0411/46 78 932</p>	<p>Honkong</p> <p>Rexroth (China) Ltd. 19 Cheung Shun Street 1st Floor, Cheung Sha Wan, Kowloon, Honkong Telefon: 741 13 51/-54 and 741 14 30 Telex: 3346 17 GL REX HX Telefax: 786 40 19 786 07 33</p>	<p>India</p> <p>Mannesmann Rexroth (India) Ltd. INDRAMAT Division Plot. 96, Phase III Peenya Industrial Area Bangalore - 560058 Telefon: 80/839 21 01 80/839 73 74 Telex: 845 5028 RexB Telefax: 80/839 43 45</p>	<p>Japan</p> <p>Rexroth Co., Ltd. INDRAMAT Division I.R. Building Nakamachidai 4-26-44 Tsuzuki-ku, Yokohama 226 Japan Telefon: 045/942-72 10 Telefax: 045/942-03 41</p>
<p>Korea</p> <p>Rexroth-Seki Co Ltd. 1500-12 Da-Dae-Dong Saha-Gu, Pusan, 604-050 Telefon: 051/264 90 01 Telefax: 051/264 90 10</p>	<p>Korea</p> <p>Seo Chang Corporation Ltd. Room 903, Jeail Building 44-35 Yoido-Dong Youngdeungpo-Ku Seoul, Korea Telefon: 02/780-82 07 -9 Telefax: 02/784-54 08</p>	<p>Mexico</p> <p>Motorización y Diseño de Controles, S.A. de C.V. Av. Dr. Gustavo Baz No. 288 Col. Parque Industrial la loma Apartado Postal No. 318 54060 Tlalnepantla Estado de Mexico Telefon: 5/397 86 44 Telefax: 5/398 98 88</p>	
<p>USA</p> <p>Rexroth Corporation INDRAMAT Division 5150 Prairie Stone Parkway Hoffman Estates, Illinois 60192 Telefon: 847/645-36 00 Telefax: 857/645-62 01</p>	<p>USA</p> <p>Rexroth Corporation INDRAMAT Division 2110 Austin Avenue Rochester Hills, Michigan 48309 Telefon: 810/853-82 90 Telefax: 810/853-82 90</p>		

Customer service locations outside of Europe

