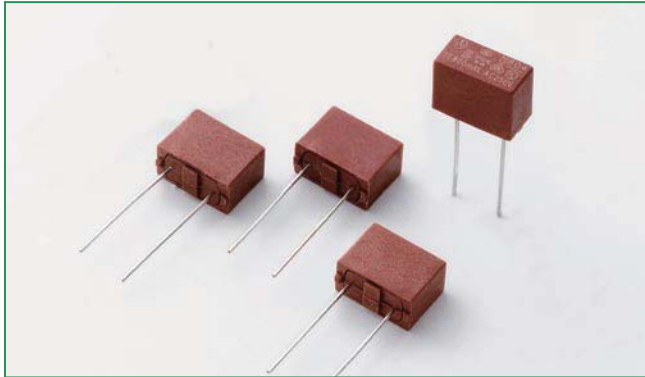

RoHS **Pb** **804 Series Fuse, TE, Time-Lag Fuse**

Description

The 804 Series is a TE UMF, TT time lag type subminiature fuse designed for overcurrent protection. It is 250V rated and designed in accordance to IEC 60127-4.

Features

- Lead-free and RoHS Compliant
- Reduced PCB space requirements
- Direct solderable or plug-in versions
- Low internal resistance
- Internally approved
- Shock safe casing
- Vibration resistant
- Halogen Free







Applications

- Battery Charger
- Consumer Electronics
- Power Supplies
- Industrial Controllers





Electrical Characteristics

% of Ampere Rating	Opening Time
125%	3600 secs Minimum
200%	120 secs Maximum
1000%	100 milliseconds Minimum 1 secs Maximum

Agency Approvals

Agency	Agency File Number	Ampere Range
	E242325	800mA – 6.3A
	DE1-42667	800mA, 1.25A – 6.3A
	CQC10012048703	800mA, 1.25A – 6.3A
	NBK060111-JP1021A	1A – 2.5A
	NBK060111-JP1021B	3.15A – 5A
	NBK060111-JP1021C	6.3A
	SU05024-10004 to 10005	800mA – 6.3A

Electrical Characteristics

Amp Code	Ampere Rating	Rated Voltage	Interrupting Rating 50-60Hz/ cos = 1	Voltage Drop $1.0 \times I_N$ max [mV]	Power Dissipation $1.25 \times I_N$ max [mW]	Melting Integral $10 \times I_N$ min [A ² s]	Agency Approvals				
											
0800	800mA	250V	150A/250VAC	218	332	12	x	x	x	x	x
1100	1.00A	250V	150A/250VAC	171	324	20	x	x			x
1125	1.25A	250V	150A/250VAC	151	352	30	x	x	x	x	x
1160	1.60A	250V	150A/250VAC	135	464	51	x	x	x	x	x
1200	2.00A	250V	150A/250VAC	183	486	80	x	x	x	x	x
1250	2.50A	250V	150A/250VAC	118	675	136	x	x	x	x	x
1315	3.15A	250V	150A/250VAC	163	818	189	x	x	x	x	x
1400	4.00A	250V	150A/250VAC	128	945	346	x	x	x	x	x
1500	5.00A	250V	150A/250VAC	98	1091	748	x	x	x	x	x
1630	6.30A	250V	150A/250VAC	78	1125	1099	x	x	x	x	x

Temperature Derating Curve

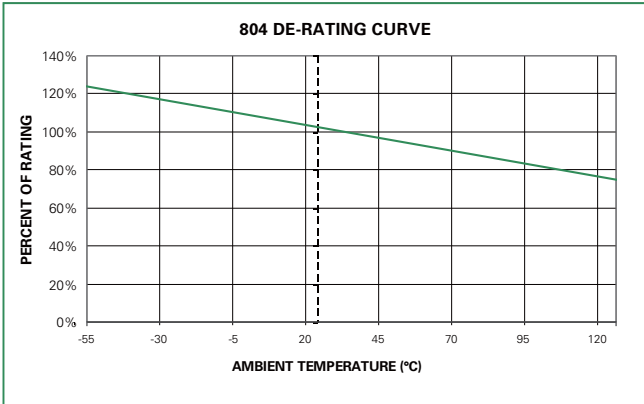

Average Time Current Curves

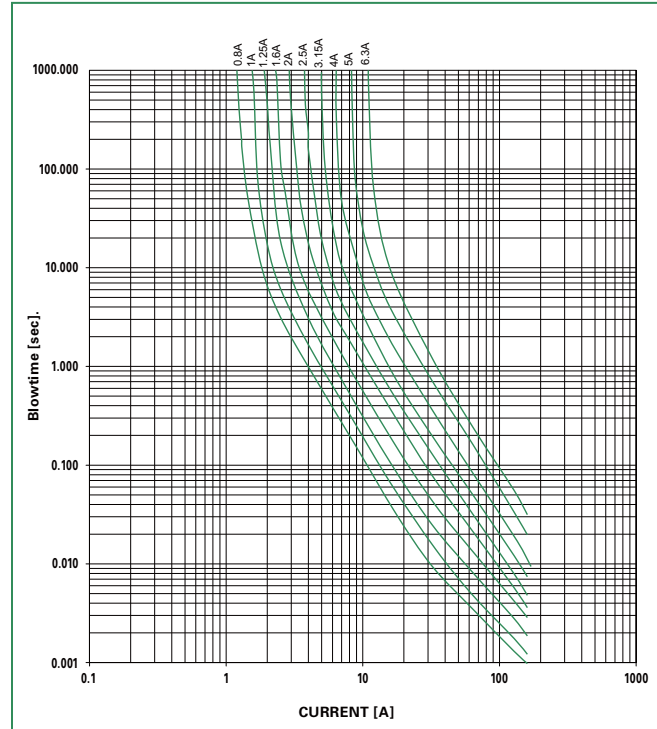

Soldering Parameters - Wave Soldering

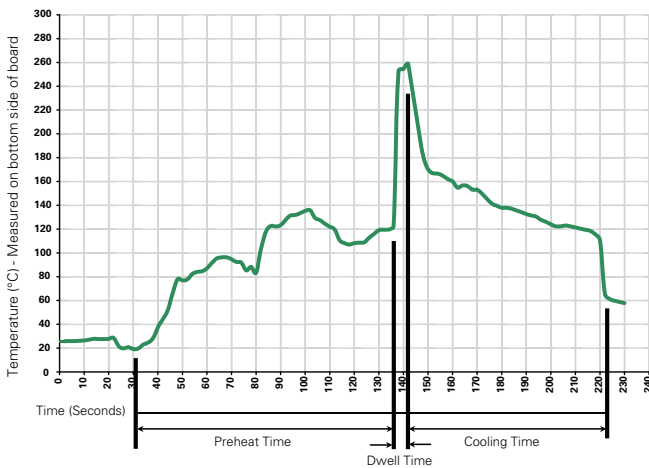

Recommended Process Parameters:

Wave Parameter	Lead-Free Recommendation
Preheat: (Depends on Flux Activation Temperature)	(Typical Industry Recommendation)
Temperature Minimum:	100° C
Temperature Maximum:	150° C
Preheat Time:	60-180 seconds
Solder Pot Temperature:	260° C Maximum
Solder Dwell Time:	2-5 seconds

Recommended Hand-Solder Parameters:

Solder Iron Temperature: 350° C +/- 5°C
Heating Time: 5 seconds max.

Note: These devices are not recommended for IR or Convection Reflow process.

Product Characteristics

Materials	Base/Cap: Black Thermoplastic Polyamide, UL 94V-0 Brass, Nickel-plated Cap Round Pins: Copper, Sn Plated
Lead Pull Strength	10 N (EN 60068-2-21)
Solderability	260°C, ≤ 3s. (Wave) 350°C, ≤ 1s. (Soldering Iron)
Soldering Heat Resistance	260°C, 10s. (IEC 60068-2-20) 350°C, 3s. (Soldering Iron)

Operating Temperature	-40°C to +125°C (consider de-rating)
Climatic Category	-40°C/+85°C/21 days (EN 60068-1, -2-1, -2-2, -2-78)
Stock Conditions	+10°C to +60°C relative humidity 75% yearly average, without dew, maximum value for 30 days – 95%
Vibration Resistance	24 cycles at 15 min. each (EN60028-2-6) 10 - 60Hz at 0.75 mm amplitude 20 – 2000Hz at 10g acceleration

Dimensions

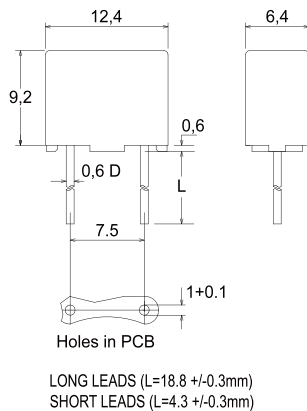

Part Numbering System

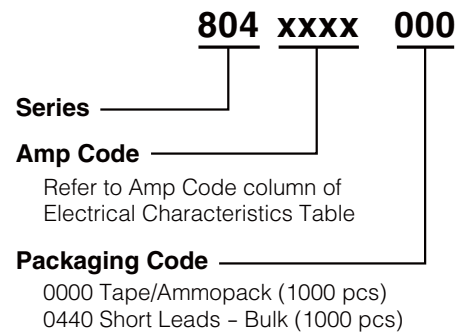

Packaging

Packaging Option	Packaging Specification	Quantity	Quantity & Packaging Code	Reel Size
804 Series				
Tape & Ammopack	N/A	1,000	000	N/A
Short Leads	N/A	1,000	044	N/A