

S-Beam Tension and Compression Load Cell, Models 151 & 152

Figure 1. Product Nomenclature

For example, **CA151NL,1BB,2U,6F,9A,30B** defines a Model 151 S-Beam Load Cell, 250 N range, -10 °C to 40 °C [14 °F to 104 °F] temperature compensation, unamplified, integral PVC cable, 10 point, tension and compression output.

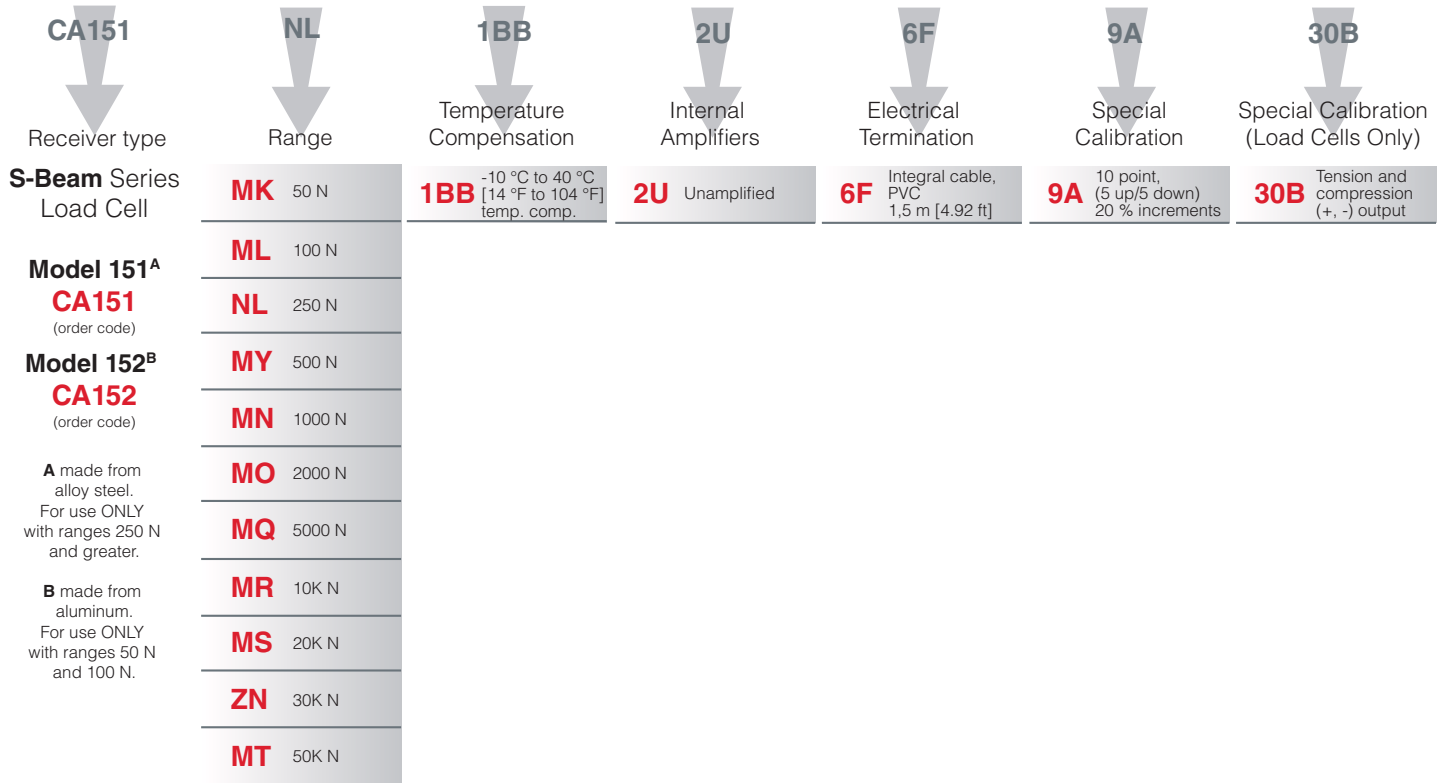

Table 6. Order Guide

Range	Description	Order Code	Honeywell Part Number
50 N	Model 152 50 N	CA152MK,1BB,2U,6F,30B	060-P662-01
100 N	Model 152 100 N	CA152ML,1BB,2U,6F,30B	060-P662-02
250 N	Model 151 250 N	CA151NL,1BB,2U,6F,30B	060-P663-01
500 N	Model 151 500 N	CA151MY,1BB,2U,6F,30B	060-P663-02
1000 N	Model 151 1,000 N	CA151MN,1BB,2U,6F,30B	060-P664-01
2000 N	Model 151 2,000 N	CA151MO,1BB,2U,6F,30B	060-P665-01
5000 N	Model 151 5,000 N	CA151MQ,1BB,2U,6F,30B	060-P665-02
10K N	Model 151 10,000 N	CA151MR,1BB,2U,6F,30B	060-P665-03
20K N	Model 151 20,000 N	CA151MS,1BB,2U,6F,30B	060-P666-01
30K N	Model 151 30,000 N	CA151ZN,1BB,2U,6F,30B	060-P666-02
50K N	Model 151 50,000 N	CA151MT,1BB,2U,6F,30B	060-P666-03

S-Beam Tension and Compression Load Cell, Models 151 & 152

DIMENSIONAL DRAWINGS

Figure 2. Model 151 & 152 Dimensions

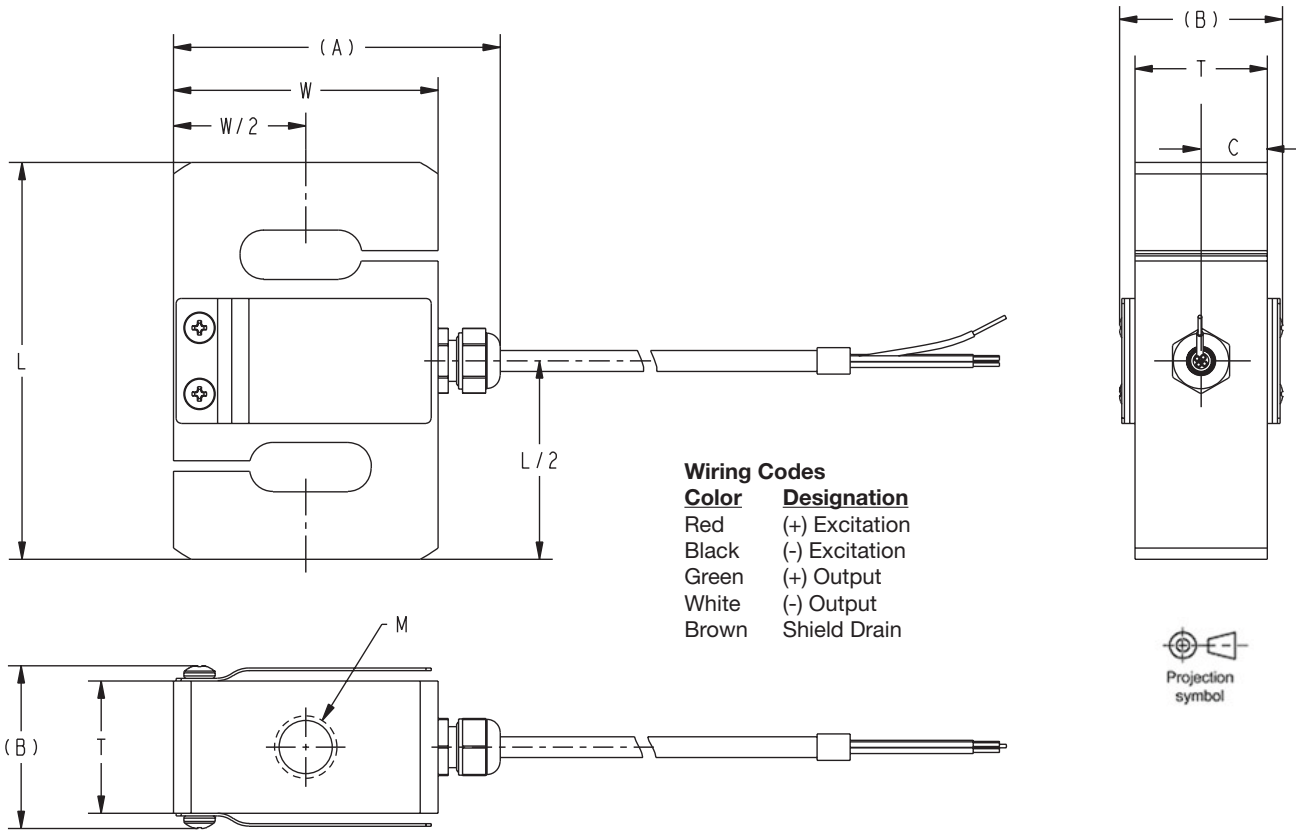

Capacity (N)	Model	Case Material	A (Reference)	B (Reference)	C	T	L	M	W
50	152	aluminum	68 mm [2.68 in]	24,5 mm [0.96 in]	9 mm [0.35 in]	18 mm [0.71 in]	70 mm [2.76 in]	M8 x 1.25/ thru	56 mm [2.20 in]
100	152	aluminum	68 mm [2.68 in]	24,5 mm [0.96 in]	9 mm [0.35 in]	18 mm [0.71 in]	70 mm [2.76 in]	M8 x 1.25/ thru	56 mm [2.20 in]
250	151	alloy steel	62,5 mm [2.46 in]	18,5 mm [0.73 in]	6,35 mm [0.25 in]	12,7 mm [0.50 in]	63,5 [2.5 in]	M6 x 1/thru	50,8 mm [2.0 in]
500	151	alloy steel	62,5 mm [2.46 in]	18,5 mm [0.73 in]	6,35 mm [0.25 in]	12,7 mm [0.50 in]	63,5 [2.5 in]	M6 x 1/thru	50,8 mm [2.0 in]
1000	151	alloy steel	62,5 mm [2.46 in]	25,4 mm [1.0 in]	9,5 mm [0.37 in]	19 mm [0.75]	76,2 mm [3.0 in]	M10 x 1.5/ thru	50,8 mm [2.0 in]
2000	151	alloy steel	62,5 mm [2.46 in]	25,4 mm [1.0 in]	9,5 mm [0.37 in]	19 mm [0.75]	76,2 mm [3.0 in]	M12 x 1.75/ thru	50,8 mm [2.0 in]
5000	151	alloy steel	62,5 mm [2.46 in]	25,4 mm [1.0 in]	9,5 mm [0.37 in]	19 mm [0.75]	76,2 mm [3.0 in]	M12 x 1.75/ thru	50,8 mm [2.0 in]
10k	151	alloy steel	62,5 mm [2.46 in]	31,5 mm [1.24 in]	12,7 mm [0.50 in]	25,4 mm [1.0 in]	76,2 mm [3.0 in]	M12 x 1.75/ thru	50,8 mm [2.0 in]
20k	151	alloy steel	86 mm [3.39 in]	31,5 mm [1.24 in]	19 mm [0.74 in]	25,4 mm [1.0 in]	108 mm [4.25 in]	M18 x 1.5/ thru	76,2 mm [3.0 in]
30k	151	alloy steel	86 mm [3.39 in]	31,5 mm [1.24 in]	19 mm [0.74 in]	25,4 mm [1.0 in]	108 mm [4.25 in]	M18 x 1.5/ thru	76,2 mm [3.0 in]
50k	151	alloy steel	86 mm [3.39 in]	37,5 [1.48 in]	25,4 mm [1.0 in]	31,8 mm [1.25 in]	108 mm [4.25 in]	M18 x 1.5/ thru	76,2 mm [3.0 in]