

SP1

Compact String Pot • Voltage Divider Output

SP1-xx w/o Mounting Bracket

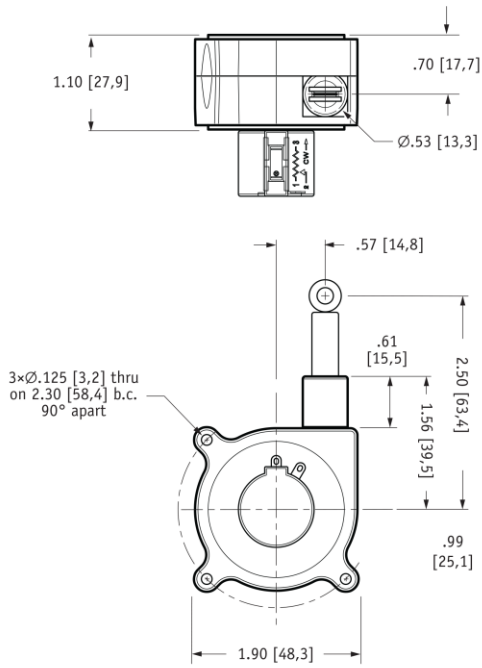

DIMENSIONS ARE IN INCHES [MM]
tolerances are 0.04 IN. [1,0 MM] unless otherwise noted.

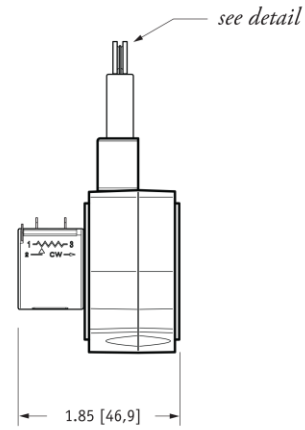
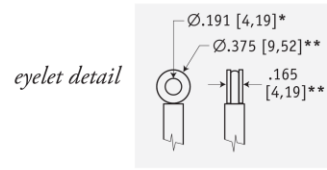

* tolerance = +.005 - .001 [+0,1 -0,0]
** tolerance = +.005 - .005 [+0,1 -0,1]

SP1-xx w/ Mounting Bracket

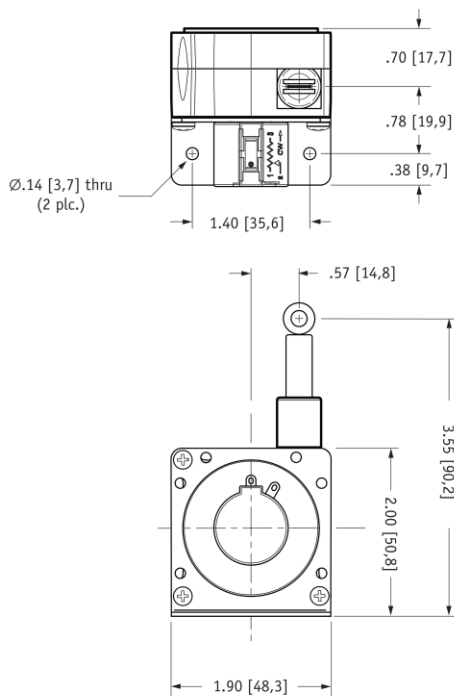

DIMENSIONS ARE IN INCHES [MM]
tolerances are 0.04 IN. [1,0 MM] unless otherwise noted.

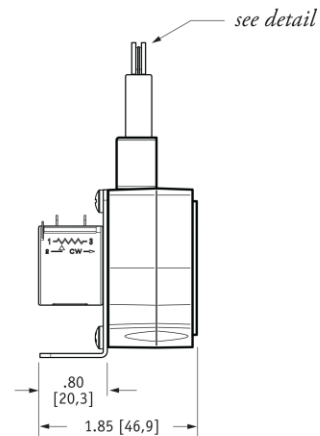
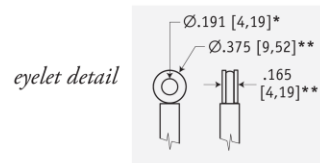

* tolerance = +.005 - .001 [+0,1 -0,0]
** tolerance = +.005 - .005 [+0,1 -0,1]

SP1

Compact String Pot • Voltage Divider Output

Mounting Options for SP1-xx-3

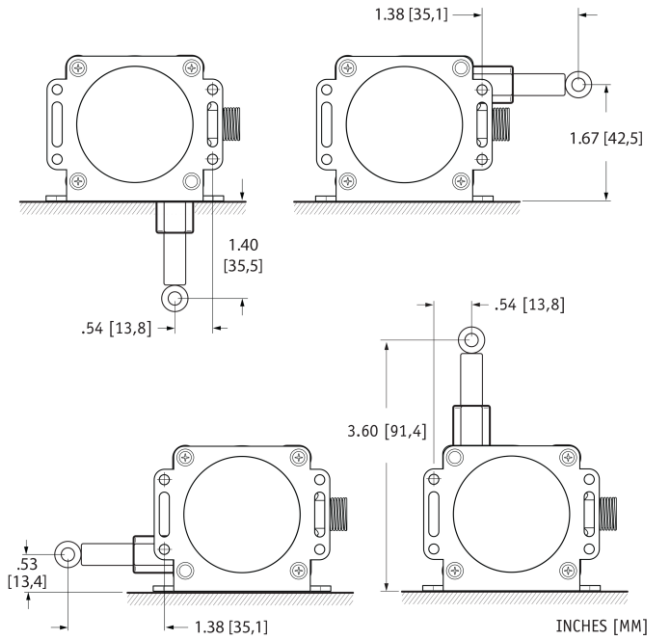
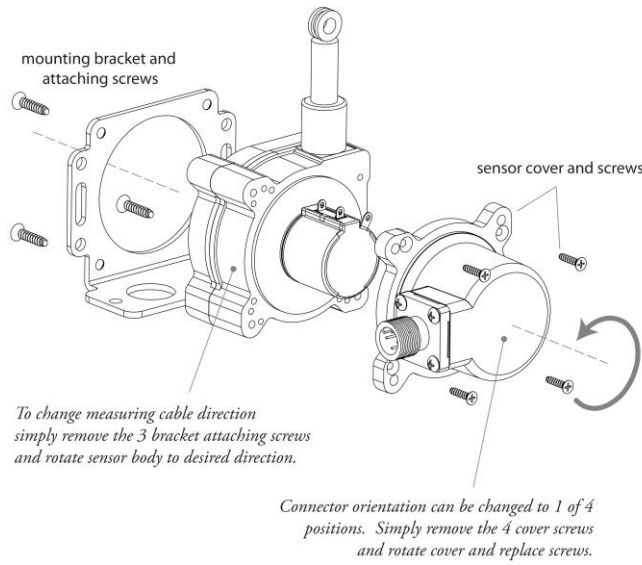

SP1-xx-3 w/o Mounting Bracket

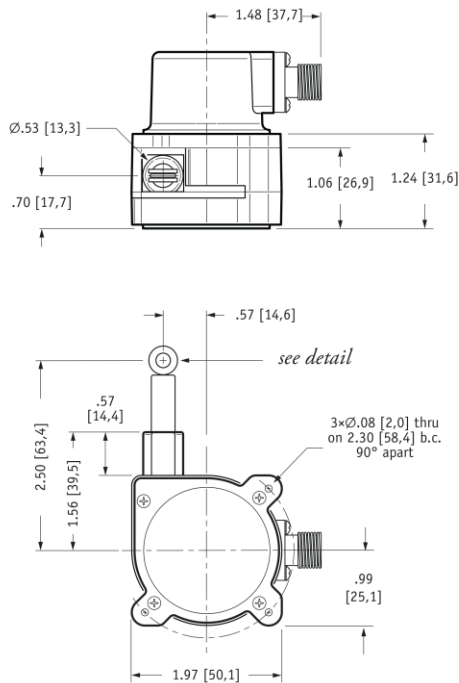

eyelet detail

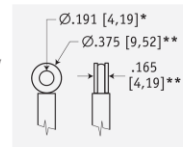

mating plug (included)

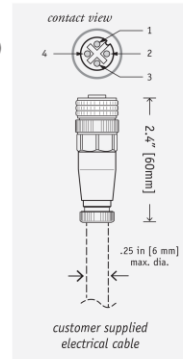
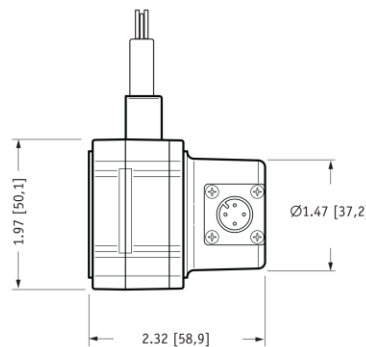

DIMENSIONS ARE IN INCHES [MM]
tolerances are 0.04 IN. [1,0 MM] unless otherwise noted.

* tolerance = +.005 -.001 [+0,1 -0,0]
** tolerance = +.005 -.005 [+0,1 -0,1]