

●Contacts

Load	Resistive load	
Contact form	SPST-NO (1a)	SPDT (1c)
Contact type	Single	
Contact material	Ag Alloy (Cd free)	
Rated load	16 A at 250 VAC 16 A at 24 VDC	16 A at 250 VAC (N.O) 5 A at 250 VAC (N.C) 16 A at 24 VDC (N.O) 5 A at 24 VDC (N.C)
Rated carry current	16 A	16 A (N.O), 5A (N.C)
Max. switching voltage	250 VAC, 24 VDC	
Max. switching current	16 A	16 A (N.O), 5 A (N.C)

■Characteristics

Item	Classification Relay function	SPST-NO (1a), SPDT (1c)	
		Single-winding Latching, Double-winding Latching	
Contact resistance *1		100 mΩ max.	
Set time		10 ms max.	
Reset time		10 ms max.	
Minimum pulse width *2		30 ms	
Maximum pulse width *2		1 min	
Insulation resistance *3		1,000 MΩ min.	
Dielectric strength	Between coil and contacts	6,000 VAC, 50/60 Hz for 1 min	
	Between contacts of the same polarity	1,000 VAC, 50/60 Hz for 1 min	
Impulse withstand voltage	Between coil and contacts	10 kV (1.2 × 50 μs)	
Insulation distance	Between coil and contacts	Clearance: 6.4 mm, Creepage: 8 mm	
Vibration resistance	Destruction	10 to 55 to 10 Hz, 0.75 mm single amplitude (1.5 mm double amplitude)	
	Malfunction	10 to 55 to 10 Hz, 0.75 mm single amplitude (1.5 mm double amplitude) at Set status 10 to 55 to 10 Hz, 0.75 mm single amplitude (1.5 mm double amplitude) at Reset status (Except SPST-NO)	
Shock resistance	Destruction	1,000 m/s ²	
	Malfunction	150 m/s ² at Set status 50 m/s ² at Reset status (Except SPST-NO)	
Durability	Mechanical *4	5,000,000 operations min.	
	Electrical *4	50,000 operations min.	
Ambient operating temperature		-40° to 85°C (with no icing or condensation)	
Ambient operating humidity		5% to 85%	
Weight		Approx. 10 g	

Note. Values in the above table are initial values.

*1. The contact resistance is measured with 1 A applied at 5 VDC using a fall-of-potential method.

*2. These are measured at a coil temperature of 23°C and rated coil voltage.
Pulse duty factor should be 10% MAX.

*3. The insulation resistance is measured between coil and contacts and between contacts of same polarity at 500 VDC.

*4. Operated with input pulse width "30 ms".

■Engineering Data

●Maximum Switching Power

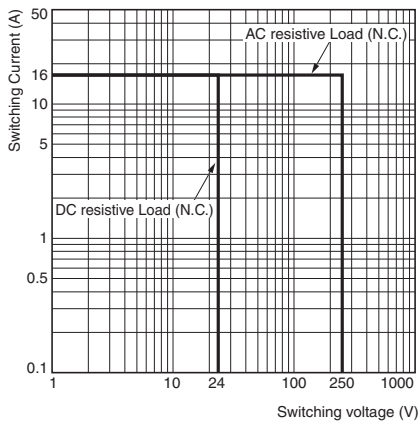

●Ambient Temperature vs. Maximum Coil Voltage

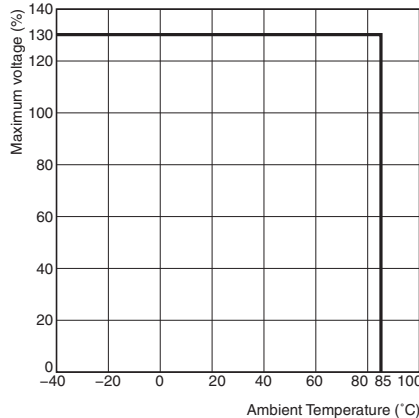

Note. Maximum voltage of Set pulse and Reset pulse at duty factor 10%.

●Malfunction Shock

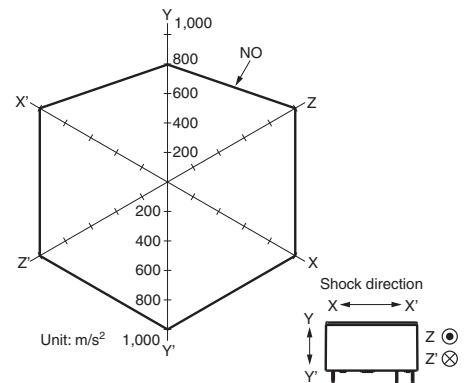

Sample: G5RL-K1A-E 12VDC

No. of relays: 5 pcs

Test Conditions: Shock is applied in ±X, ±Y, and ±Z directions three times each with Set and Reset status to check the number of contact malfunctions.

Standard value: 50 m/s² with Set status

100 m/s² with Reset status

■Dimensions

(Unit: mm)

G5RL-U1A-E

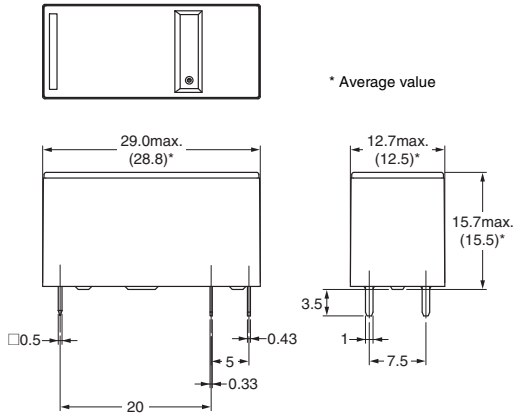
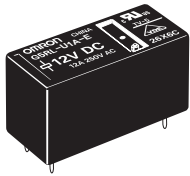

PCB Mounting Holes (BOTTOM VIEW)

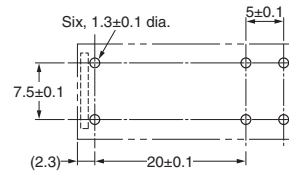

Terminal Arrangement/ Internal Connections (BOTTOM VIEW)

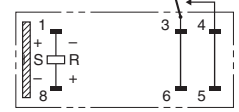

Note. Orientation marks are indicated as follows: □ ▨

G5RL-U1-E

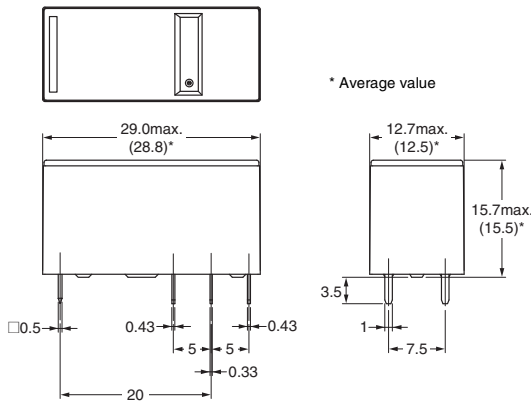
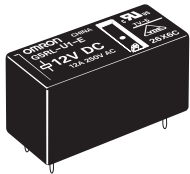

PCB Mounting Holes (BOTTOM VIEW)

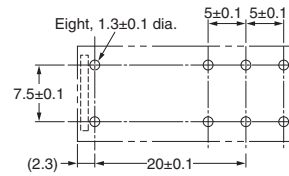

Terminal Arrangement/ Internal Connections (BOTTOM VIEW)



Note. Orientation marks are indicated as follows: □ ▨

G5RL-K1A-E

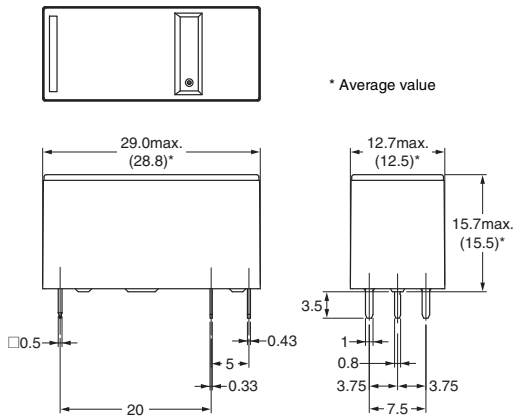
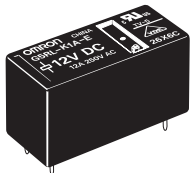

PCB Mounting Holes (BOTTOM VIEW)

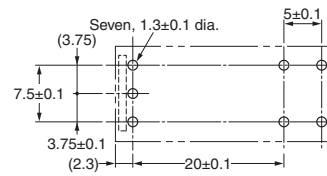

Terminal Arrangement/ Internal Connections (BOTTOM VIEW)

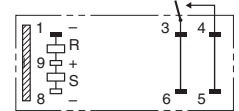

Note. Orientation marks are indicated as follows: □ ▨

G5RL-K1-E

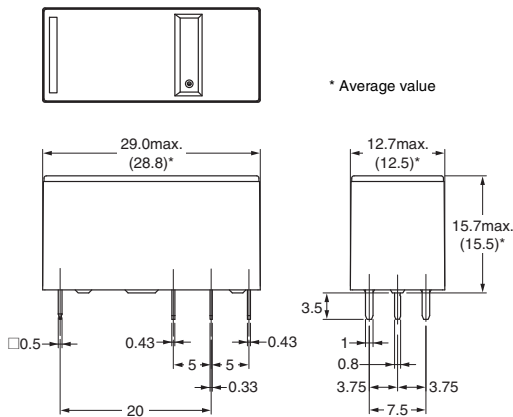
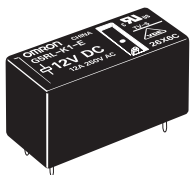

PCB Mounting Holes (BOTTOM VIEW)

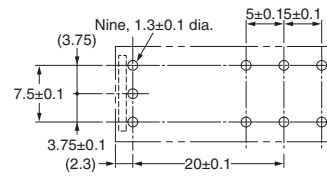

Terminal Arrangement/ Internal Connections (BOTTOM VIEW)

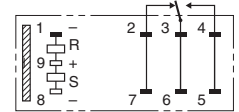

Note. Orientation marks are indicated as follows: □ ▨