

30 Watts

- Compact Size
- Medical Approvals
- Single Outputs from 3.3 to 48 V
- PCB Mount, Open Frame & Chassis Mount
- Encapsulated PCB & Chassis Mount
- Class II
- Peak Load Capability



The EML30 is a series of open frame and encapsulated AC-DC single output power supplies designed for medical applications. The series provides a number of flexible mechanical options including PCB mount, open frame, chassis mount with screw terminals and a DIN Rail option. With approvals to world-wide medical safety standards, compliance with class B for both conducted and radiated emissions and a 130%, 30s peak load capability, these class II isolation parts benefit system designers with easy integration into the latest healthcare products and applications.

Dimensions:

EML30:

- (-P): 2.96 x 1.36 x 1.05" (75.2 x 34.6 x 26.7 mm)
- (-T): 3.46 x 1.36 x 1.00" (87.9 x 34.6 x 25.4 mm)
- (-E): 3.10 x 1.50 x 1.10" (78.7 x 38.1 x 27.9 mm)
- (-S): 3.78 x 1.57 x 1.12" (96.0 x 40.0 x 28.5 mm)

Models & Ratings

Output Power	Output Voltage	Output Current		Efficiency	Model Number ^(2,3)
		Nominal	Peak ⁽¹⁾		
20 W	3.3 VDC	6.00 A	7.80 A	72%	EML30US03
30 W	5.0 VDC	6.00 A	7.80 A	75%	EML30US05
30 W	9.0 VDC	3.33 A	4.33 A	80%	EML30US09
30 W	12.0 VDC	2.50 A	3.25 A	80%	EML30US12
30 W	15.0 VDC	2.00 A	2.60 A	87%	EML30US15
30 W	24.0 VDC	1.25 A	1.63 A	82%	EML30US24
30 W	36.0 VDC	0.83 A	1.08 A	82%	EML30US36
30 W	48.0 VDC	0.62 A	0.81 A	87%	EML30US48

Notes

1. Peak load lasting <30 s with a maximum duty cycle of 10%, average output power not to exceed nominal.
2. Add suffix to model number to define type: add '-P' for PCB mount, add '-T' for chassis mount, add '-E' for encapsulated, add '-S' for screw terminals.
3. A Screw terminal version (-S) is available with DIN clip attached, add suffix 'D', e.g. EML30US24-SD, DIN rail mounting kit is available as a separate item, order code ECL25/30 DIN CLIP.

Summary

Characteristic	Minimum	Typical	Maximum	Units	Notes & Conditions
Input Voltage Range	85		264	VAC	Derate from 100% at 90 VAC to 90% at 85 VAC
	120		370	VDC	
No Load Input Power			0.3	W	
Efficiency	75	80	82	%	See Models & Ratings table
Operating Temperature	-20		+70	°C	Derate linearly from 100% at +50 °C to 50% at +70 °C
EMC	EN55022 Level B Conducted & Radiated, EN61000-4, EN61000-3, EN60601-1-2				
Safety Approvals	EN60601-1, ANSI/AAMI ES60601-1. IEC60601-1				

Input

Characteristic	Minimum	Typical	Maximum	Units	Notes & Conditions
Input Voltage Range	85		264	VAC	
	120		370	VDC	
Input Frequency	47		63	Hz	
Input Current - Full Load		0.55/0.32		A rms	At 115/230 VAC
No Load Input Power			0.3	W	
Inrush Current		20/40		A	At 115/230 VAC
Earth Leakage Current					Class II construction no earth
Input Protection	Internal T2.0 A/250 VAC fuse fitted in line and neutral				

Output

Characteristic	Minimum	Typical	Maximum	Units	Notes & Conditions
Output Voltage	3.3		48	VDC	See Models and Ratings table
Initial Set Accuracy			±1	%	
Output Voltage Adjustment			±5	%	Not encapsulated units
Minimum Load	0			A	No minimum load required
Start Up Delay			2	s	
Start Up Rise Time			14	ms	
Hold Up Time	12			ms	at full load and 115 VAC
Line Regulation			±0.5	%	
Load Regulation			±1	%	
Transient Response			4	%	Deviation, recovery within 1% in less than 500 μs for a 25% load change
Ripple & Noise			50	mV pk-pk	3.3-5 V versions, 20 MHz bandwidth
			120	mV pk-pk	12-15 V versions, 20 MHz bandwidth
			200	mV pk-pk	24-48 V versions, 20 MHz bandwidth
Overvoltage Protection	195		216	% Vnom	3.3 V versions, recycle input to reset
	115		130	% Vnom	All other versions, recycle input to reset
Overload Protection	120		170	%	
Short Circuit Protection					Trip & Restart (hiccup mode)
Temperature Coefficient			0.05	%/°C	

General

Characteristic	Minimum	Typical	Maximum	Units	Notes & Conditions
Efficiency	75	80	82	%	See Models & Ratings table
Isolation: Input to Output	4000			VAC	
Switching Frequency		70		kHz	
Power Density			7	W/in ³	PCB Mount version
Mean Time Between Failure		>400		kHrs	MIL-HDBK-217F, +25 °C GB
Weight		0.13 (60)		lb (g)	Open frame versions
		0.35 (160)		lb (g)	Encapsulated version
		0.37 (170)		lb (g)	Screw terminal version

Environmental

Characteristic	Minimum	Typical	Maximum	Units	Notes & Conditions
Operating Temperature	-20		+70	°C	Derate linearly from 100% at +50 °C to 50% at +70 °C
Storage Temperature	-40		+85	°C	
Cooling					Convection-cooled
Humidity			95	%RH	Non-condensing
Operating Altitude			3048	m	
Shock	IEC68-2-27, 30 g, 11 ms half sine, 3 times in each of 6 axes				
Vibration	IEC68-2-6, 2 g, 10 Hz to 500 kHz, 10 mins/cycle, 60 mins each cycle				

EMC: Emissions

Phenomenon	Standard	Test Level	Criteria	Notes & Conditions
Conducted	EN55022/11:2010	Class B		
Radiated	EN55022/11:2010	Class B		
Harmonic Current	EN61000-3-2			Class A
Voltage Flicker	EN61000-3-3			

EMC: Immunity

Phenomenon	Standard	Test Level	Criteria	Notes & Conditions
ESD	EN61000-4-2	3	A	6 kV contact, 8 kV air discharge
Radiated	EN61000-4-3	10 V/m	A	80% mod
EFT	EN61000-4-4	3	A	
Surges	EN61000-4-5	3	A	
Conducted	EN61000-4-6	10 Vrms	A	
Magnetic Fields	EN61000-4-8	30 A/m	A	
Dips and Interruptions	EN60601-1-2	70% U_T for 500 ms	A	
		40% U_T for 100 ms	A	40% of U_T dip is performance criteria A if load is reduced to 35% based on 100 VAC
		<5% U_T for 10 ms	A	
		<5% U_T for 5000 ms	B	

Safety Approvals

Safety Agency	Safety Standard	Notes & Conditions
CB Report	IEC60601-1 Ed 3 Including Risk Management	Medical
UL	ANSI/AAMI ES60601-1:2005 & CSA C22.2, No.60601-1:08	Medical
TUV	EN60601-1/A11:2011	Medical

Means of Protection	Category
Primary to Secondary	2 x MOPP (Means of Patient Protection)
	IEC60601-1 Ed 3

Mechanical Details

Open Frame - PCB Mount (-P)

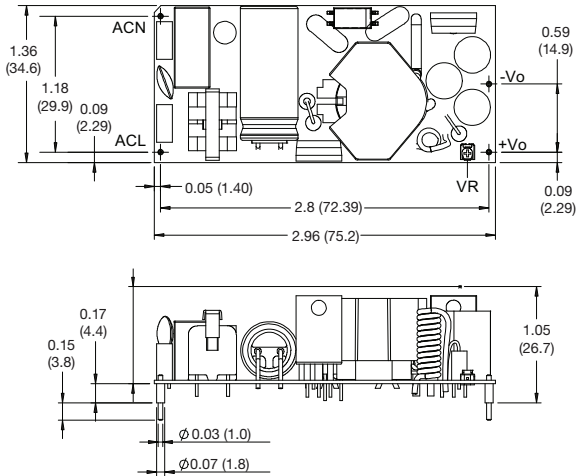

Encapsulated (-E)

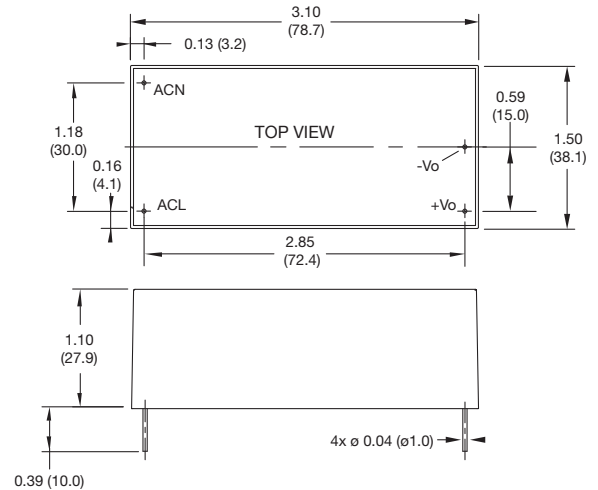

Open Frame - Chassis Mount (-T)

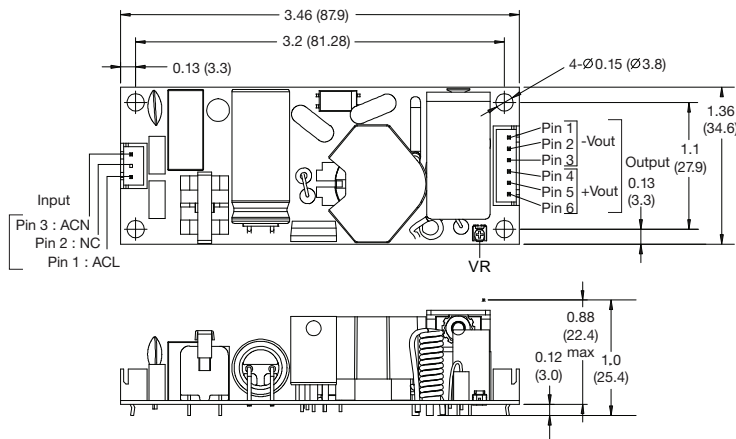

Screw Terminal (-S)

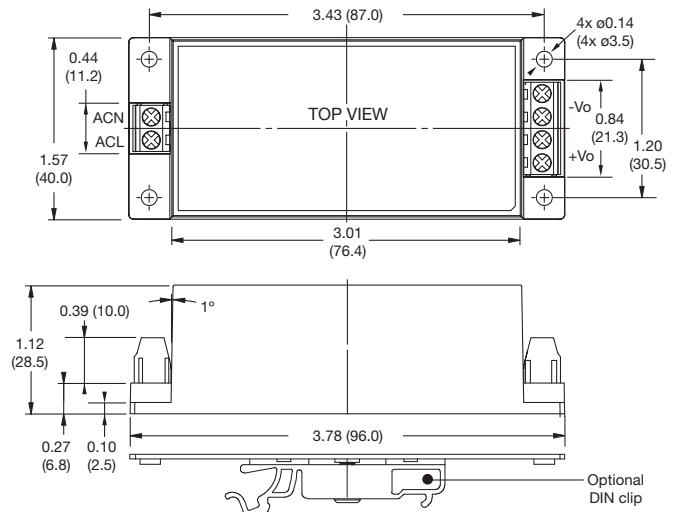

Notes

- Dimensions in inches (mm).
- Weight: P Version: 0.13 lbs (60 g)
T Version: 0.13 lbs (60 g)
E Version: 0.35 lbs (160 g)
S Version: 0.37 lbs (170 g)
- Tolerances: x.xx = ± 0.02 (x.x = ± 0.5)
x.xxx = ± 0.01 (x.xx = ± 0.25)

Mating Connectors (-T version only)

Input Connector: JST XHP-3
Output Connector: JST XHP-6
Crimps: SPH-002T-P0.5S
Cable harness with 300mm wire available, order part no. ECL25 LOOM KIT