



Operations Manual
AC-Servo Controller
SC-610

No. 900105 11/2005

24.11.2005-FA

HARMONIC DRIVE AG has tried to ensure that the information given in this manual is correct at time of going to print.

However Harmonic Drive AG may not be held responsible for any typographical mistakes or errors in contents of this manual. The information is subject to change without prior notice. Harmonic Drive AG would appreciate notice of any mistakes in the text.

HARMONIC DRIVE AG owns the copyright to this document, which is supplied to customers on the understanding that it will not be reproduced or disclosed in whole or in part, without the express permission of Harmonic Drive AG.

**Harmonic Drive AG
Hoenbergstraße 14**

**D-65555 Limburg/ Lahn
Germany**

**Tel.: +49-6431/ 5008-0
Fax.: +49-6431/ 5008-18
Internet www.harmonicdrive.de**

©2005

Contents

	General Information and Safety Guide Lines	2			
1.0	Specification	5	5.0	System Set Up Procedure	35
1.1	Usage Definitions	5	5.1	Presets	35
1.2	Identification	5	5.2	System Set Up Step by Step	36
1.3	Features	6	6.0	Status Indicators	39
1.4	Declaration of Conformity	6	6.1	Status Monitor	39
1.5	EMC Conformity and CE Marking.	7	6.2	LED Regeneration Load	41
1.6	Technical Data	7	7.0	I/O Hardware Description	41
1.6.1	Power Section	7	7.1	Input Signals	41
1.6.2	24VDC Input	8	7.2	Output Signals	43
1.6.3	Velocity Controller	8	7.3	Resolver (X8)	44
1.6.4	Encoder Inputs	8	7.4	Encoder Output (X7)	45
1.6.4.1	Master-Encoder Input (X9)	8	7.5	Encoder (X8) Hiperface/ EnDat	45
1.6.4.2	Hiperface (X8)	8	7.6	Encoder (X8) TTL-Encoder.....	46
1.6.4.3	EnDat (X8)	8	7.7	I/O-Expansion for 256 Pos. (X12)	47
1.6.4.4	TTL-Encoder (X8)	8	7.7.1	Input Signals (X12)	47
1.6.5	Encoder Output (X7)	9	7.7.2	Output Signals (X12)	48
1.6.6	Pulse/Direction Input	9			
1.6.7	Serial Interface	10	APPENDIX		
1.6.8	Mechanical Section	10	Appendix A		
1.6.9	Environmental Section	10	EMC Installation Instruction	A2	
1.6.10	Power Supply Section	11	EMC Wiring Principle	A3	
1.6.10.1	Regeneration	11	Appendix B		
1.6.10.2	Rectifier Section	11	Dimensions	A5	
2.0	Installation Recommendations	12	Appendix C		
2.1	Safety Notice	12	Troubleshooting	A7	
2.2	Electrical Installation	12	Appendix D		
2.3	Mechanical Installation	13	Multi-Drop-Applications	A10	
3.0	Interconnection Diagrams	14	Appendix E		
3.1	Interconnection Diagram		Software Installation	A11	
	Hiperface/EnDat	14	Appendix F		
3.2	Interconnection Diagram Resolver	15	Definition of Motor Parameters	A12	
3.3	Interconnect. Diagram TTL-Encoder	16	Appendix G		
3.4	Connector Configuration		Wiring description for cables for FHA-C-series actuators with Hiperface ...	A13	
	I/O-Expansion	17	Appendix H		
4.0	Wiring	18	Wiring description for cables for FFA-series actuators with resolver	A14	
4.1	Power Wiring	18	Appendix I		
4.1.1	Power Supply	18	Wiring description for cables for FFA-series actuators with EnDat-encoder	A15	
4.1.2	Mains Filter	19	Appendix J		
4.1.3	Motor Wiring	20	Wiring description for cables for FHA-Cmini-series actuators with TTL-encoder	A16	
4.1.4	24VDC Connection	20	Appendix K		
4.1.5	Regeneration Resistor Wiring	21	Wiring description for cables for CHA-series actuators with Hiperface	A17	
4.2	Control- and Signal Wiring	22			
4.2.1	Control Inputs	22			
4.2.2	Control Outputs	25			
4.2.3	Resolver	25			
4.2.4	Encoder Output	26			
4.2.5	Master Encoder Input	26			
4.2.6	Command Input	27			
4.2.7	Interface Cables	28			
4.3	Minimum Wiring Diagram	29			

General Information and Safety Guidelines

Microsoft and MS-DOS are registered trademarks, and Windows is a trademark of Microsoft Corporation. UL and cUL are registered trademarks of Underwriters Laboratories.

CE Compliance

A custom unit may be required, contact Harmonic Drive. Compliance to Directive 89/336/EEC is the responsibility of the system integrator. Servo controller, motor and all system components must have proper shielding, grounding and filtering.

Product Notice Intended use:

These drives are intended for use in stationary ground based applications in industrial power installations according to the standards EN60204 and VDE0160. They are designed for machine applications that require variable speed controlled three phase brushless AC motors.

These drives are not intended for use in applications such as:

- Home appliances
- Medical instrumentation
- Mobile vehicles
- Ships
- Airplanes

Unless otherwise specified, this drive is intended for installation in a suitable enclosure. The enclosure must protect the control from exposure to excessive or corrosive moisture, dust and dirt or abnormal ambient temperatures. The exact operating specifications are found in Section 1 of this manual.

The installation, connection and control of drives is a skilled operation, disassembly or repair must not be attempted.

In the event that a control fails to operate correctly, contact the place of purchase for return instructions.

Safety Notice:

This equipment contains high voltages. Electrical shock can cause serious or fatal injury. Only qualified personnel should attempt the start-up procedure or troubleshoot this equipment.

This equipment may be connected to other machines that have rotating parts or parts that are driven by this equipment. Improper use can cause serious or fatal injury. Only qualified personnel should attempt the start-up procedure or troubleshoot this equipment.

- System documentation must be available at all times.
- Keep non-qualified personnel at a safe distance from this equipment.
- Only qualified personnel familiar with the safe installation, operation and maintenance of this device should attempt start-up or operating procedures.
- Always remove power before making or removing any connections to this control.

PRECAUTIONS: Classifications of cautionary statements.

⚠ WARNING: Indicates a potentially hazardous situation which, if not avoided, could result in injury or death.

⚠ Caution: Indicates a potentially hazardous situation which, if not avoided, could result in damage to property.

⚠ WARNING: Do not touch any circuit board, power device or electrical connection before you first ensure that power has been disconnected and there is no high voltage present from this equipment or other equipment to which it is connected. Electrical shock can cause serious or fatal injury.

⚠ WARNING: Be sure that you are completely familiar with the safe operation of this equipment. This equipment may be connected to other machines that have rotating parts or parts that are controlled by this equipment. Improper use can cause serious or fatal injury.

⚠ WARNING: Be sure all wiring complies with the National Electrical Code and all regional and local codes or CE Compliance. Improper wiring may cause a hazardous condition.

⚠ WARNING: Be sure the system is properly grounded before applying power. Do not apply AC power before you ensure that grounds are connected. Electrical shock can cause serious or fatal injury.

⚠ WARNING: Do not remove cover for at least five (5) minutes after AC power is disconnected to allow capacitors to discharge. Electrical shock can cause serious or fatal injury.

⚠ WARNING: Improper operation of control may cause violent motion of the motor shaft and driven equipment. Be certain that unexpected motor shaft movement will not cause injury to personnel or damage to equipment. Peak torque of several times the rated motor torque can occur during control failure.

⚠ WARNING: Motor circuit may have high voltage present whenever AC power is applied, even when motor is not rotating. Electrical shock can cause serious or fatal injury.

⚠ WARNING: If a motor is driven mechanically, it may generate hazardous voltages that are conducted to its power input terminals. The enclosure must be grounded to prevent a possible shock hazard.

⚠ WARNING: When operating a motor with no load coupled to its shaft, remove the shaft key to prevent injury if it were to fly out when the shaft rotates.

⚠ WARNING: The motor shaft will rotate during the autotune procedure. Be certain that unexpected motor shaft movement will not cause injury to personnel or damage to equipment.

⚠ WARNING: A DB Resistor may generate enough heat to ignite combustible materials. To avoid fire hazard, keep all combustible materials and flammable vapors away from brake resistors.

⚠ WARNING: The user must provide an external hard-wired emergency stop circuit to disable the control in the event of an emergency.

⚠ Caution: Suitable for use on a circuit capable of delivering not more than the RMS symmetrical short circuit amperes listed here at rated voltage.

<u>Horsepower</u>	<u>RMS Symmetrical Amperes</u>
1-50	5,000

⚠ Caution: To prevent equipment damage, be certain that the input power has correctly sized protective devices installed as well as a power disconnect.

- ⚠ Caution:** Avoid locating control immediately above or beside heat generating equipment, or directly below water or steam pipes.
- ⚠ Caution:** Avoid locating control in the vicinity of corrosive substances or vapors, metal particles and dust.
- ⚠ Caution:** For UL installations, do not connect any resolver cable shields to the motor frame. At a minimum, resolver signal integrity will be compromised and damage to the control may result. For CE installations, refer to CE guidelines stated in Sections 3 and A1 of this manual.
- ⚠ Caution:** Do not connect AC power to the control terminals U, V and W. Connecting AC power to these terminals may result in damage to the control.
- ⚠ Caution:** Harmonic Drive recommends not using „Grounded Leg Delta“ transformer power leads that may create ground loops and degrade system performance. Instead, we recommend using a four wire Wye.
- ⚠ Caution:** Logic signals are interruptible signals; these signals are removed when power is removed from the drive.
- ⚠ Caution:** Controls are intended to be connected to a permanent main power source, not a portable power source. Suitable fusing and circuit protection devices are required.
- ⚠ Caution:** The safe integration of the drive into a machine system is the responsibility of the machine designer. Be sure to comply with the local safety requirements at the place where the machine is to be used. In Europe this is the Machinery Directive, the ElectroMagnetic Compatibility Directive and the Low Voltage Directive. In the United States this is the National Electrical code and local codes.
- ⚠ Caution:** Controls must be installed inside an electrical cabinet that provides environmental control and protection. Installation information for the drive is provided in this manual. Motors and controlling devices that connect to the drive should have specifications compatible to the drive.
- ⚠ Caution:** Violent jamming (stopping) of the motor shaft during operation may damage the motor and control.
- ⚠ Caution:** Do not tin (solder) exposed wires. Solder contracts over time and may cause loose connections.
- ⚠ Caution:** Electrical components can be damaged by static electricity. Use ESD (electro-static discharge) procedures when handling this control.
- ⚠ Caution:** Ensure that resolver or encoder wires are properly connected. Incorrect installation may result in improper rotation or incorrect commutation.
- ⚠ Caution:** The holes in the top and bottom of the enclosure are for cable clamps. Be sure to use an M4 bolt 12mm in length. Longer bolts may short circuit the electrical components inside the control.

1.0 Specification

1.1 Usage Definitions

The drives of the SC-610 series are electrical equipment for industrial power installations. They are designed for machine applications, which need variable speed controlled three-phase A.C. motors.

This product is only for use in industrial applications as described in norms EN60204 and VDE0160. This means use drive in stationary ground based applications only. It is not meant for use in home appliances, medical equipment, cars, ships or airplanes.

Before the drive is put into operation, please contact your Electric-Supply-Company for special operating conditions.

1.2 Identification

SC	610	5	A	A	A	H
	Product Series (Op. Modes)	Nominal Current	Power Supply	Not used this time	Demand/ Input	Motor Feedback
Servo Controller	Current Control, Velocity Control, Pulse Follower, Hand-wheel, Position Control	2: 2.5 Amp. 5: 5 Amp. 7: 7.5 Amp.	A: 230VAC B: 115VAC C: 230VAC plus 24VDC D: 115VAC plus 24VDC		A: $\pm 10V$, 4 bin. Inputs B: $\pm 10V$, 8 bin. Inputs A/B: Pulse Follower, Handwheel	R: Resolver H: Hiperface D: EnDat E: TTL-Encoder

1.3 Features

**The SC610 series are 1 axis drives with integrated power supply.
They provide the following features:**

POWER SECTION:

- Input-voltage: 1- (direct) or 1-phase with transformer (250V_{AC} max)
- 3 output current versions (2.5A/5A/7.5A) available.
- Ratio peak : nominal current = 2:1.
Both values independently adjustable.
- All drives are short circuit proof (phase/phase and phase/PE) and require no minimum load.

CONTROL I/O Section:

- 9 opto-isolated control inputs for dedicated drive functions
- Optional point-to-point positioning for up to 16/256 predefined positions
- Resolver / Hiperface input
- Master Encoder input
- Serial interface (RS232C / RS485) for communication and programming

GENERAL:

- Protection class IP20 (acc. To DIN40 050 / IEC144)
- Cooling: self-ventilation (internal ventilator)
- UL approved (UL-File-No.: E128059)

- Output power up to 3kVA
- Internal power supply consisting of rectification, smoothing, regeneration circuit and surge current protection
- Brushless-servomotors (2 to 12 poles) can be connected. (Feedback: 1-pole pair resolver or Hiperface)
- Power wiring via terminal screws (max. wiring diameter 2.5mm²)
- Resolver feedback
- Hiperface feedback

- Diagnostic display on front panel
- Amplifier configuration adjustable via software
- Software amplifier tuning capability with graphic program.
- Wiring of control inputs and outputs via plug type screw connection (max. wiring diameter 1,5mm²) or SUB-D connector

- Isolation classification according to DIN 0110 with overvoltage category III

1.4 Declaration of Conformity

Herewith we declare, that our products are components only and not ready for immediate or instant use within the meaning of "Safety law of appliance", "EMC Law" or "Machine directive".

The final mode of operation is defined only by the insertion into the user's construction.

It is the responsibility of the user to verify that his construction is in accordance with existing regulations.

It is prohibited by law to put the machine into operation before verifying that the machine is in accordance with EC directive 89/392 and 921/368.

The supplier declares product conformity with the following standards:

DIN VDE 0160 / 05.88	Electronic equipment for use in electrical power installations
DIN VDE 0100	Erection of power installations with nominal voltages up to 1000V
DIN IEC 326 Part 1 / 10.90	Design and use of printed boards
DIN VDE 0110 Part 1-2 / 01.89	Dimensioning of clearance and creepage distances
DIN VDE 0110 Part 20 / 08.90	
EN 60529 / 10.91	Degrees of protection provided by enclosures

1.5 EMC - Conformity and CE - Marking

The application of EMC conformal component and part systems relieves the observance of EMC Guidelines and the guarantee of conformity for the manufacturer of machines. Therefore all standard components and part systems will be tested according to the requirements of EMC regulation.

Those tests will be executed by a competent and independent institution. The conformity of the products will be confirmed by a declaration of conformity from the European Community.

The installation instructions refer to elimination of radio interference as well as to immunity from noise for Harmonic Drive Systems.

Thereby the user is informed about the EMC critical parts. The examples don't show the complete possibilities of cabinet components or constructions.

Guidelines for CE Conformity

- **Machine Guideline (89/392/EWG)** - **Machine Safety Law**
- **EMV Guideline (89/336/EWG)** - **EMC Law**
- **Low Voltage Guideline (73/23/EWG)** - **Machine Safety Law**

1.6 Technical Data

All values at $T_{amb} = 40\text{ °C}$, if not otherwise specified. NOTE: Operation at maximum ratings

1.6.1 Power Section

General	Unit	SC-610-2	SC-610-5	SC-610-7
Nominal DC-Bus-Voltage	V _{DC}	160 / 320	160 / 320	160 / 320
Output Voltage Line/Line fundamental wave; @V _{DC-Bus} = 320V	V _{RMS}	0 ... 230		
Nominal Phase Current ($\pm 10\%$)	A _{RMS}	2,5	5,0	7,5
Peak Phase Current ($\pm 10\%$)	A _{RMS}	5 ¹⁾ 2,4s (+0,5/-0)s	10 ¹⁾ 2,4s (+0,5/-0)s	15 ¹⁾ 1,25s (+0,5/-0)s
Nominal Output Power	kVA	1,01	2,17	2,99
Efficiency	%	> 95		
Output Frequency	Hz	0 ... 1000		
Nominal Switching Frequency	kHz	8,0		

¹⁾ valid for zero current initial condition

1.6.2 24VDC Input (optional)

24V-Input (optional)	Unit	SC-610-X
Input Voltage Range absolute min./max. ¹⁾ max. V _{ripple} = $\pm 10\%$	V _{DC}	20.4 ... 28.8
Input Current; @ 24V _{DC}	A _{RMS}	1.75
Surge Current at Power On @ 24V _{DC} ; @ 100ms	A _{RMS}	4,0

¹⁾ NOTE: Operation at maximum ratings may impair the useful life time

1.6.3 Velocity Controller

Velocity Controller	Unit	SC-610-X
Command Input	VDC	0 ... ±10
Command Signal Resolution	bit	14 bit
Cycle time	µs	250

Velocity Feedback	Unit	SC-610-X
Feedback System	-	Resolver
Feedback-Resolution set automatically by software	-	Resolution: 14bit ±4,9mV
Pole Pairs	-	1
Resolver – Winding-Ratio	-	0.5

1.6.4 Encoder-Inputs

1.6.4.1 Master Encoder-Input (X9)

Encoder Input	Unit	SC-610-X
Signal	-	RS422
Operating Mode	-	A, A/ ; B, B/ and C, C/ (quadrature)
Max. Input Frequency	MHz	2.5 (quadrature) / 1.25 Pulse and Direction

1.6.4.2 Hiperface (X8)

Hiperface Input	Unit	SC-610-X
Signal	-	Sinosoidal / Parameter channel RS485
Operating Mode	-	1024 Sin/Cos periods per motor revolution and absolute multiturn position / quadrature counting
Power Supply		8V / 800mA max.

1.6.4.3 EnDat (X8)

Hiperface Input	Unit	SC-610-X
Signal	-	Sinosoidal / Parameter channel RS485/ Clock
Operating Mode	-	2048 Sin/Cos periods per motor revolution and absolute multiturn position / quadrature counting
Power Supply		5V / 800mA max.

1.6.4.4 TTL-Encoder (X8)

TTL-Encoder Input	Unit	SC-610-X
Signal	-	Rectangular (A, A/, B, B/, C, C/, U, U/, V, V/, W, W/
Operating Mode	-	2000 pules per motor revolution / quadrature counting
Power Supply		5V / 250mA max.

1.6.5 Encoder-Output (X7)

Encoder-Output	Unit	SC-610-X
Signal	-	RS422
Max. frequency	KHz	100
Supply voltage	VDC	5 ±5 %
Output voltage	VDC	$V_{OH} = 2.5 \text{ min.} / V_{OL} = 0.5 \text{ max.}$
Output current	mA	max. 20
Signal form		Rectangular, pos. logic
Pulse lengths		$P_1 = 0.5 P_0; P_C = 0.25 P_0$
Encoder-Resolution at Hiperface and EnDat-feedback	ppr	same as the number of sine/cosine cycles per revolution
Encoder-Resolution at resolver feedback	ppr	512 / 1024 / 2048 / 4096 ¹⁾

¹⁾ factory default

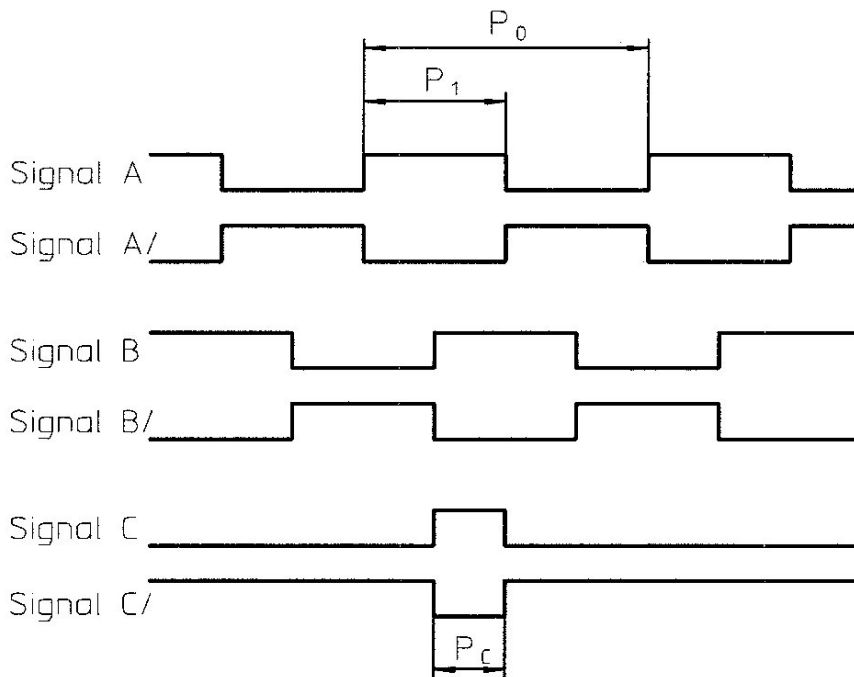

The above given signal sequence depends on the connected servo actuator and its feedback system and is specified as follows:

Actuator type	Direction of rotation at motor shaft	Direction of rotation at gear outputt
FHA-C-HIPERFACE	Counter clockwise	Clockwise
FFA-Resolver/ EnDat	Clockwise	Counter clockwise
FPA-Resolver/ EnDat	Clockwise	Clockwise
FHA-Cmini/ TTL-Encoder	Clockwise	Counter clockwise

1.6.6 Pulse / Direction-Input (X3)

Pulse / Direction Input	Unit	SC-610-X
Signal	VDC	12-29 / opto-isolated
Operating Mode	-	Pulse and Direction
Max. Input Frequency	MHz	1
Cycle time	ms	1

1.6.7 Serial Interface

STANDARD

<i>RS232 - Interface</i>	Unit	SC-610-X
Communication (4 wire)	-	RS232C (not galvanically isolated, with RTS / CTS)
Transmission Rate	Baud	up to 57600 max (Software selectable)

Adjustable by DIP-switch AS1.10

<i>RS485 – Interface</i>	Unit	SC-610-X
Communication	-	RS485 (not galvanically isolated)
Transmission Rate	Baud	9600, 19200

1.6.8 Mechanical Section

<i>Mechanical</i>	Unit	SC-610-2	SC-610-5	SC-610-7
Mounting	-	Panel		
Dimensions of Basic Units	mm	67,5 x 173 x 152,5	92,5 x 173 x 152,5	109 x 173 x 152,5
Dimensions for Units with I/O- Expansion for 256 Positions	mm	84 x 173 x 152,5	109 x 173 x 152,5	109 x 173 x 152,5
Weights for Basic Units	kg	1,24	2,13	2,19
Weights for Units with I/O- Expansion for 256 Positions	kg	1,55	2,45	2,45

1.6.9 Environmental Section

<i>Environmental</i>	Unit	SC-610-X
Operating Temperature Range	°C	+5 ... +40 (Derating 2,5% / K bei 40°C < T ≤ 50°C)
Storage Temperature Range	°C	-25 ... +70
Humidity	%	10 ... 90 non-condensing; IEC 68-2-38
Class of Protection (Enclosure)	-	IP20
Max. Installation Altitude / M.S.L.	m	1000 Derating: 1,1% / 100m
Shock	-	10G; according to DIN IEC 68-2-6/29
Vibration	-	1G; 10 ... 150 Hz; according to DIN IEC 68-2-6/29

1.6.10 Power Supply Section

1.6.10.1 Regeneration



<i>Regeneration Control Internal</i> <i>Regeneration Resistor External</i>	Unit	SC-610-X
Switching Threshold; On / Off	VDC	383 ... 373 (at 230 VAC) 195... 188 (at 115 VAC)
Nominal / Peak Power	kW	0,25 / 2,7
Max. Regeneration Switching Current	A	7/10
Max. Load Inductance	μH	100

1.6.10.2 Rectifier Section

<i>Power Supply Internal</i>	Unit	SC-610-X
Input Voltage (+15% / -20%) f = 50 bis 60Hz	VAC	V _{in} : 230 / 115 Nominal: 230 / 115 Maximal: 265 / 130 Minimal: 90 / 90
DC-Bus-Voltage absolute min./max. ¹⁾	VDC	125 ... 360 (at 230 VAC) 125 ... 175 (at 115 VAC)
DC-Bus-Voltage absolute min./max. for 24V-Option	VDC	0 ... 350 VDC

¹⁾ NOTE: Operation at maximum ratings may impair the useful life time.

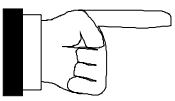
Legend:

	This is an INFORMATION sign. By observing this information whilst installing the drive future operating problems may be avoided.
	This sign means ATTENTION . Information in an ATTENTION box must always be observed otherwise dangerous situations for equipment and personnel may result.

2.0 Installation and Safety Recommendations

The following chapter contains important information regarding the **mechanical** and **electrical** installation as well **Safety Notes**.

It is strongly recommended to read and observe this chapter carefully.

2.1 Safety Notice

Qualified or trained personnel only should install the machine. Electrical rotating equipment can result in property damage, serious injury, or death, when improperly installed. Equipment should be installed in accordance with the local and safety standards for construction and guide for selection, installation and use of electrical motors and generators.

Suitable for use on a circuit capable of delivering not more than 5000Arms symmetrical amperes, 250VAC maximum per drive rating.

Electrical and/or mechanical alterations are permitted only when power is removed.

Drives with the 24V option (C, D) can have power to connector X1 without any indication. The monitor illuminates only if 24V is switched on.



2.2 Electrical Installation

The wiring, fusing and grounding must be in accordance to the national electrical code and any local codes.

Use of motor thermo switch:

It is recommended to survey the status of this protective device in the position control.

Since the leads can carry high voltage-spikes, isolation by means of a relay should be installed.

The thermal sensor mounted inside the motor of the FFA- and FHA-C-series actuators is not used in conjunction with the controllers described herein. The motor is protected by an additional motor-I²t-function running at the controller, by means of monitoring the motor effective current. As a result the thermal sensor is not used in this case!

Connect the PE of all systems to a central point. The diameter of the cable-lead must be (10mm²) min.

2.3 Mechanical Installation

For installation of your system use a cabinet with a protection class that suits your environmental conditions.

As cooling air freely enters the unit, the environment must be free from corrosive chemical substances, oil, vapor, steam, metal particles and dust.

Make sure that cooling is provided.

Make sure that the top of the unit is covered during installation to prevent particles from falling into the unit.

Mount all drives vertical (Connector X1 to the top).

Use the controller in stationary ground based applications only.

For the terminal block connections the following tightening torque has to be observed:

0.5 to 0.6Nm

Furthermore only copper conductors should be used.

Sudden blocking of the rotating motor shaft can cause serious damage to motor and drive. It is strongly recommended to install elastic stoppers in the driven machine.

For safe drive operation a clearance distances around and between the drives must be observed.

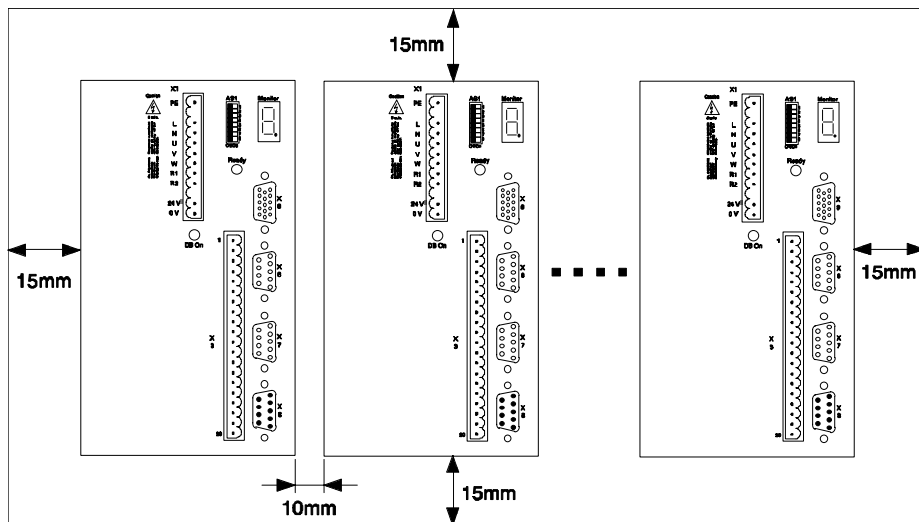

3.0 Interconnection Diagrams

3.1 Interconnection Diagram Hiperface/ EnDat

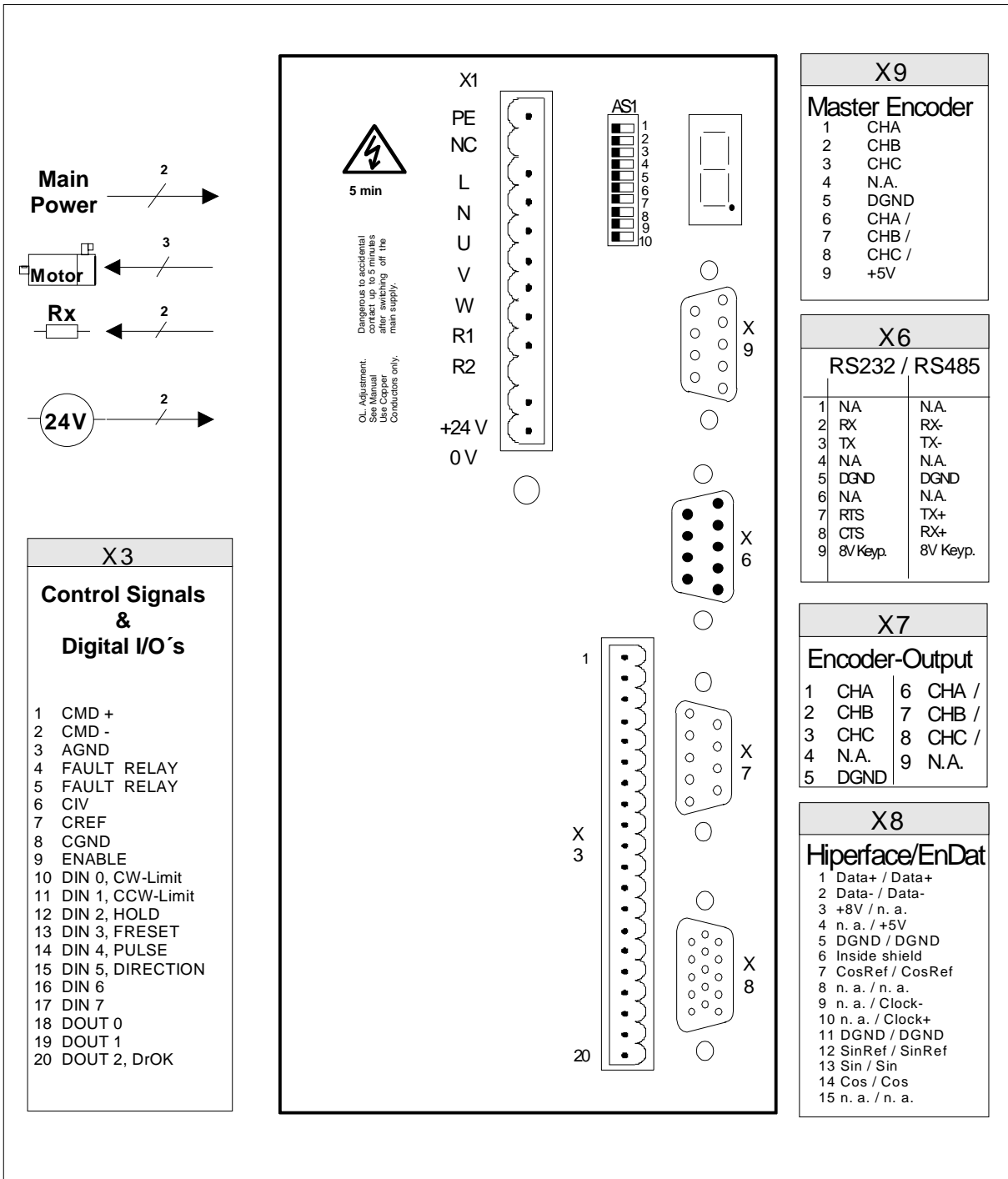

Content of delivery: mating connectors to X1, X3 and X8.

Overview of mating connectors:

- X1:** (10 pole, female)
- X3:** (20 pole, female)
- X8:** (15 pole, male, UNC)
- X6:** (9 pole, female, UNC)
- X7:** (9 pole, male, UNC)
- X9:** (9 pole, male, UNC)

3.2 Interconnection Diagram Resolver

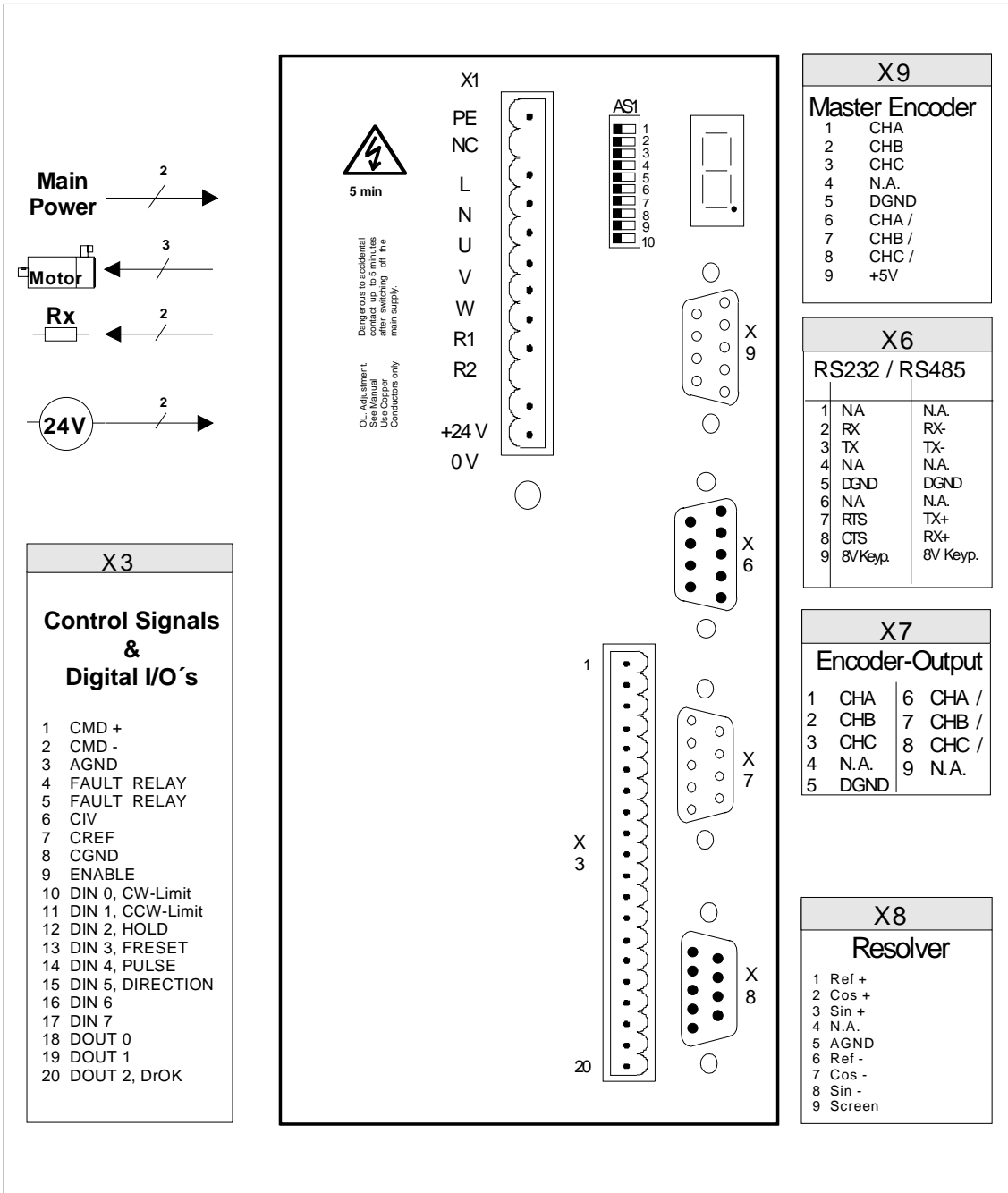

The Resolver wiring diagram is only valid for BSM motors, with FFA-motors you must change Sin+ and Sin-.

Content of delivery: mating connectors to X1, X3 and X8.

Overview of mating connectors:

- X1:** (10 pole, female)
- X3:** (20 pole, female)
- X8:** (9 pole, female, UNC)
- X6:** (9 pole, female, UNC)
- X7:** (9 pole, male, UNC)
- X9:** (9 pole, male, UNC)

3.3 Interconnection Diagram TTL-Encoder

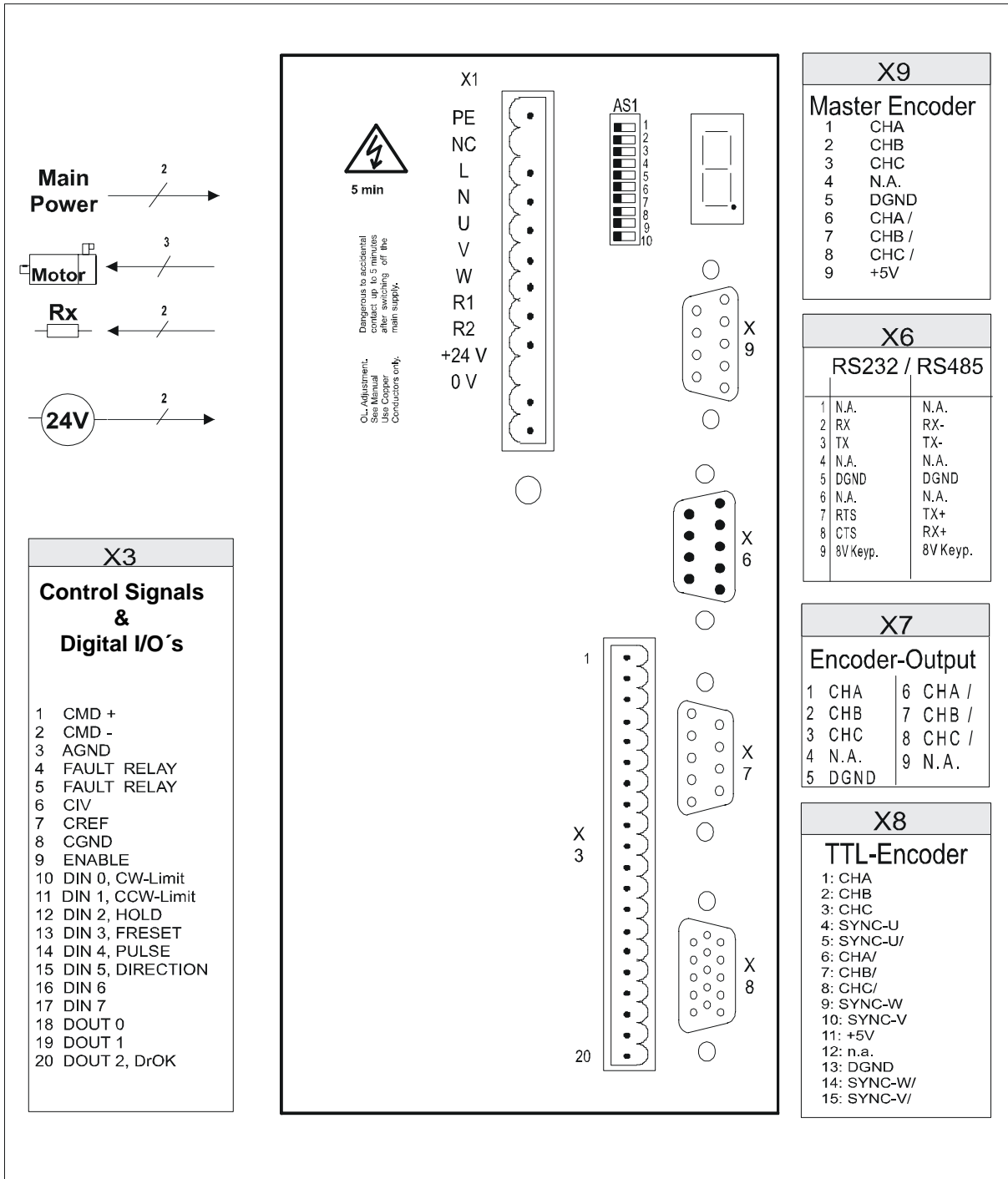

Content of delivery: mating connectors to X1, X3 and X8.

Overview of mating connectors:

X1: (10 pole, female)

X3: (20 pole, female)

X8: (15 pole, male, UNC)

X6: (9 pole, female, UNC)

X7: (9 pole, male, UNC)

X9: (9 pole, male, UNC)

3.4 Connector Configuration I/O-Expansion for 256 Positions

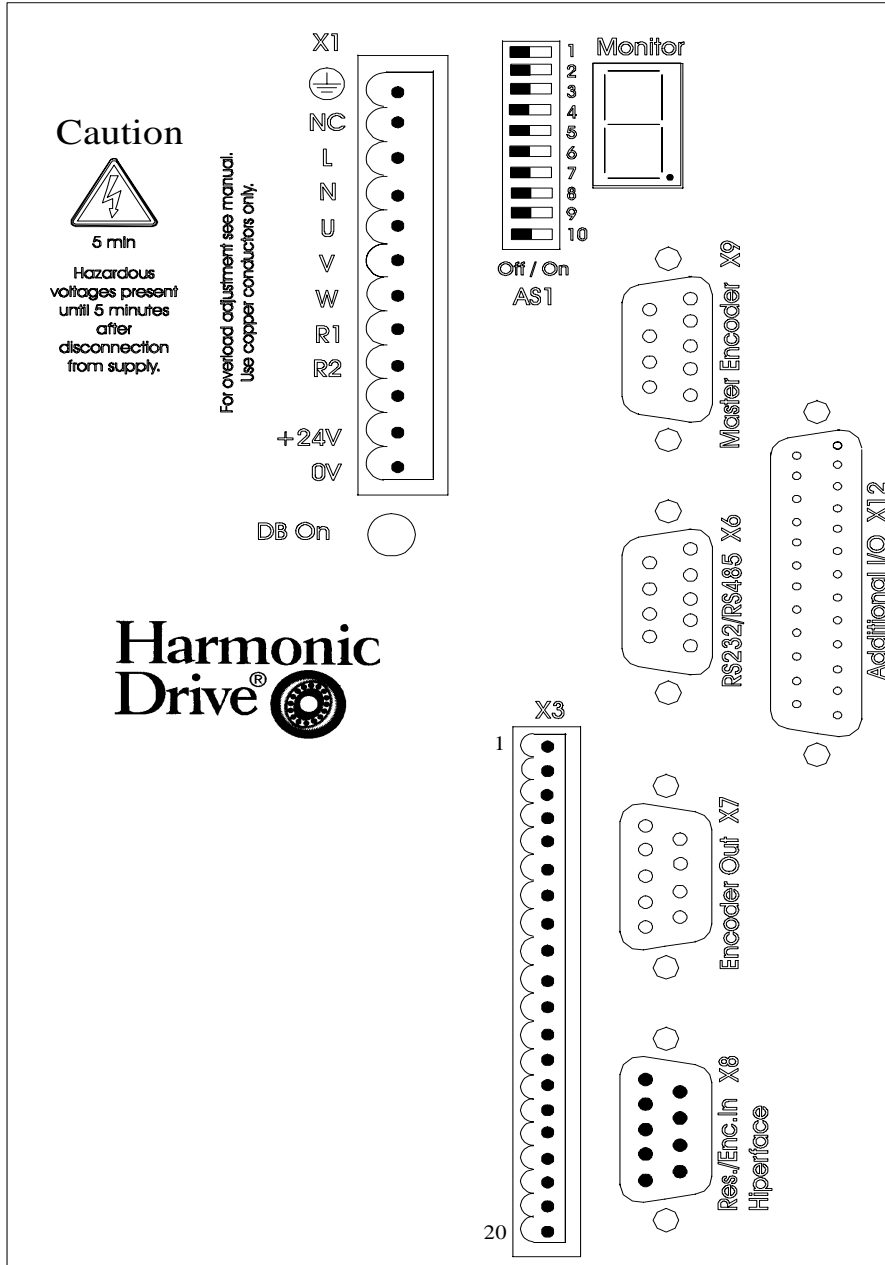

4.0 Wiring

In chapter 4.3 you will find the typical (minimum) wiring of the system. The following pages show some special applications and the typical wiring in more detail.

This chapter is valid for all units.

For the system set-up it is necessary to wire the system step by step.
It is recommended to follow the system set-up procedure, especially for users who are not very familiar with these drivers.

4.1 Power Wiring

4.1.1 Power Supply

The controller can be supplied, like shown below, with 1- phase input voltage. The power supply module consists of rectification, smoothing, regeneration circuit and surge current protection.

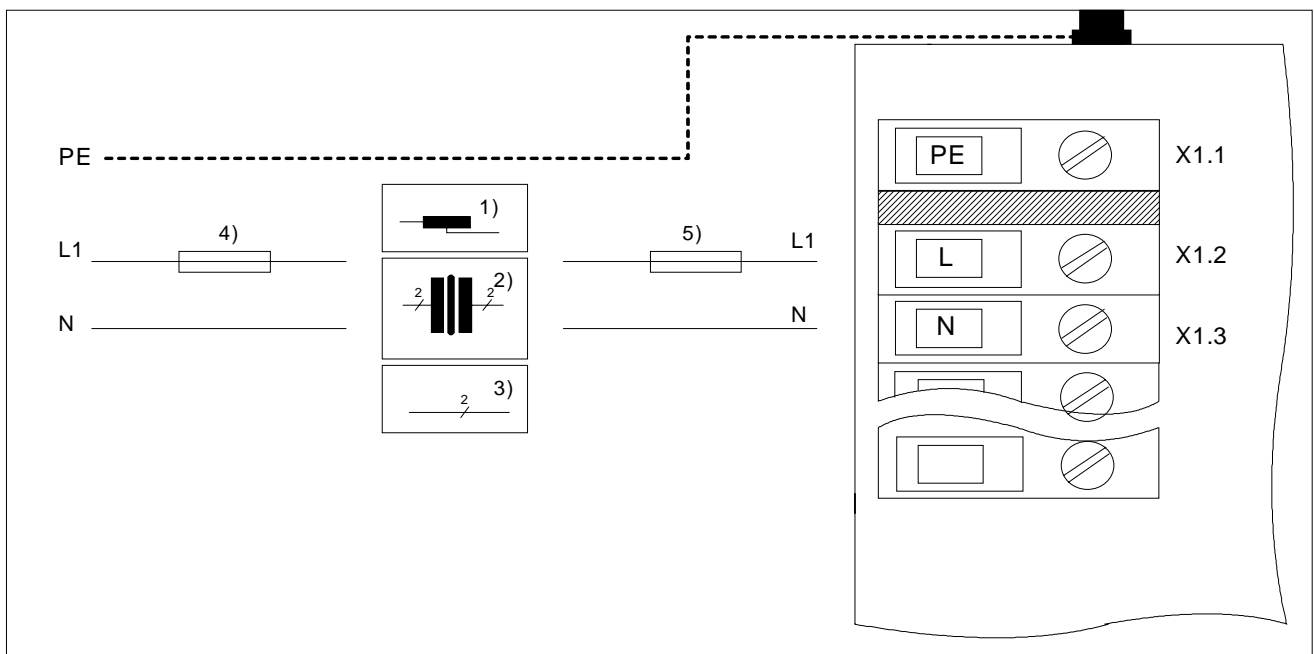

- 1) Autotransformer
- 2) Isolating transformer
- 3) Single phase connection (see also chapter 1 for input voltage)
- 4) The size of the fuse must fit in order to project the power of the transformer.
Fault current breaker are not permitted for fusing the drive (same for point 5).
- 5) Each controller is internally fused and therefore self protected. The shown input fuse is only for cable or lead protection. It is recommended to use a back-up fuse of 16A or 20A (max.); e.g. Neozed type gL slow blow type). For a fuse size of 16A a lead diameter of up to 1.5mm² can be used and for a 20A fuse the max. lead diameter has to be 2.5mm².

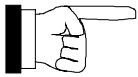

To avoid an actuation of the controller back-up fuse, it is recommended to wait about 1 min. between a main power OFF/ON cycle.

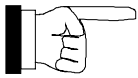

For single phase connection the voltage ripple on the DC-bus is 25Vpp for 5A (peak current SC-610-2), 50Vpp for 10A (peak current SC-610-5) and for 15 (peak current SC-610-7). This can limit the max. Speed of the motor.

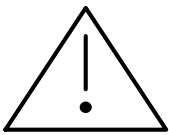

When the controller will be supplied directly from the main or via autotransformer, it is **NOT PERMITTED** to connect the Vcc- to PE. This connection will damage the controller!

4.1.2 Mains Filter (strongly required)

Following results are desired through the application of mains filters:

The electronic system should be protected from high frequency interferences which could enter via the mains cable (noise immunity) and vice versa the mains cable may not transmit interferences from the electronic systems to the adjoining components (elimination of interference).

To choose the fitting mains filter types following points have to be considered:

1. The need of power of the connected controller. Thereby the capacity and the ability of peak phase current has to be considered. The listed filter can be overloaded by 1.5 of the nominal current during 1 min./h.
2. The required or present mains impedance.

The table below shows the corresponding mains filter types:

Mains Filter for 1 Phase Input

Type	Rated Voltage [V]	Rated Current (at 40°C) [A]	Leakage Current [mA]	Weight [kg]	Harmonic Drive- ID-No.
FN - 2070 - 06 - 06	250	6	0.4	0.45	270460
FN - 2070 - 10 - 06	250	10	0.4	0.73	270461
FN - 2070 - 12 - 06	250	12	0.4	0.73	270462

Main filter dimensions are shown in appendix B.

4.1.3 Motor Wiring

The motor must be connected to the drive terminal block X1:

X1 - 4	U	Phase U
X1 - 5	V	Phase V
X1 - 6	W	Phase W

Depending on the motor there are different connections: RS/FHA-Serie is equipped with a cable exit (flying leads; not suitable for trailing applications), BSM50, 63 and 80 and FFA-series have a power connector. A wiring example is shown in chapter 4.3.

The sequence of the motor leads is not arbitrary. Therefore the motor leads must be wired in the right sequence to avoid uncontrolled motor function.

Motor Cables

All cables have to be screened. The maximum cable length is 25m.

4.1.4 24VDC - Connection (optional)

A 24V stand-by option is available for all drives. With this option the control circuits are supplied by an external voltage. The advantage of the option is that, if the main power is switched off control circuits are still supplied and position information does not get lost.

Wiring 24VDC-option:

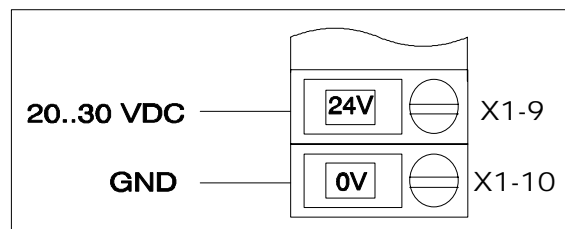

With the 24V option the DC-Bus voltage can be variable from 0V to maximum Vcc.

NOTE: The velocity controller can be optimized only for a certain DC-Bus voltage. Therefore the controller behaviour will change or different DC-Bus voltages. The current control will be not affected.



Attention: Please take care of correct connection of 24 VDC and GND!
Miswiring will lead to malfunction.

4.1.5 Regeneration Resistor Wiring

The regeneration resistor can be installed by the user (see chapter 4.3). If during normal operation **fault "1"** occurs (overvoltage; see chapter 6), a regeneration resistor must be connected to the **controller** to overcome this problem. For regeneration resistor installation the recommendations below should be observed.

Selection table:

Regeneration Power continuous [W]	Regeneration-resistor value [Ω]	Power supply [VAC]	Regeneration-Switching current [A]	Harmonic Drive-Order-No.
44	56	230	7	700889
100	39	230	10	701121

1): Duty cycle = 2% at T = 120s

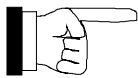

The generation resistor is not automatically included in the delivery.

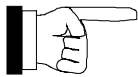

The generation resistor must be mounted horizontal on a vertical surface for full power rating. For vertical mounting on a horizontal surface the nominal load capacity is reduced to 65%.

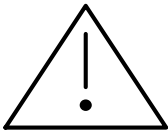

Take care of good cooling of the regeneration resistor. The ambient temperature of the resistor can be up to 200°C, in a distance of 30mm.



Keep a safe distance between regeneration resistor and flammable materials. The mounting surface can reach a temperature of 80°C.

Wiring:

The resistor must be wired with a 2 lead (2,5 mm²) screened cable. The resistor housing must be grounded.

4.2 Control- and Signal Wiring

This chapter is valid for all versions.

The wiring of the control in- and outputs can be achieved with *one* cable only unlike shown in the pictures below. The outputs *can be* wired. But there is no need for drive operation.

4.2.1 Control Inputs

The control inputs below are opto-isolated. The ground return for all inputs is "CREF", connector X3.7. Please note there are two different pin assignments for connector X3 available.

The drive can configured either in current, pulse follower, handwheel or velocity mode.

The drive is also equipped with a third control loop. Here it is a point-to-point positioning feature implemented. Up to 16 different positions (optional 256) can be stored inside the drive. These positions (including the homing routine) can be selected with the digital inputs and executed with the trigger input. Positioning is possible with actuators providing Hiperface and resolver feedback. Actuators equipped with a multiturn absolute Hiperface encoder (SCM-101) do not need a homing cycle since the absolute position is determined after power on of the drive.

Control Input Function:

Example Configuration for Speed Control and Pulse Follower

Signal	Connector Pin	Switch Position / Function	
		closed	open
ENABLE	X3.9	Drive enabled	Drive disabled
DIN 0, CWLimit ¹⁾	X3.10	Clockwise direction of rotation enabled	Clockwise direction of rotation disabled
DIN 1, CCWLimit ¹⁾	X3.11	Counter clockwise direction of rotation enabled (or position selection)	Counterclockwise dir. of rotation disabled
DIN 2, STOP	X3.12	STOP Function is active	STOP function is not active
DIN 3 FRESET	X3.13	RESET function is active Rising edge	RESET function is not active
DIN 4, Pulse	X3.14	Input pulse train (see below)	
DIN 5, Direction	X3.15	Direction signal (see below)	
DIN 6	X3.16	Digital input 1 = logical 1	Digital input 1 = logical 0
DIN 7	X3.17	Digital input 2 = logical 1	Digital input 2 = logical 0

¹⁾ Please note that servo axes incorporating Harmonic Drive gears (i. e. FHA-, FFA- and RS-series) will be effected by a change of the turning direction. The `MOTORDIRECTION` keyword can be used to change motor direction.

Example Configuration for Position Control

Signal	Connector Pin	Switch Position / Function	
		closed	open
ENABLE	X3.9	Drive enabled	Drive disabled
DIN 0	X3.10	Input no. 2 for position selection	
DIN 1	X3.11	Input no. 3 for position selection	
DIN 2,QUIT	X3.12	Quit running positioning process	Positioning process will be done
DIN 3, FRESET	X3.13	RESET function active	RESET function not active
DIN 4, HOME FLAG	X3.14	Home flag = closing (or rising) edge	Home flag = opening (or falling) edge
DIN 5, TRIGGER	X3.15	Trigger = closing (or rising) edge	Trigger = opening (or falling) edge
DIN 6	X3.16	Input no. 0 for position selection	
DIN 7	X3.17	Input no. 1 for position selection	

Wiring proposal for control inputs see chapter 4.3. Hardware description of the inputs refer to chapter 7.

More about control inputs:

"PULSE & DIR": A drive has a pulse and a direction input. These inputs are like a stepper motor interface. The incoming pulses (frequency) determine the velocity of the motor and the direction input the sense (CW, if high level and CCW if low level) of motor shaft rotation.

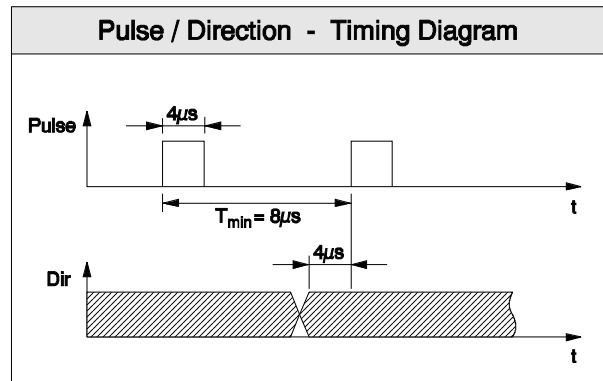

"STOP": If the input is activated the motor will decelerate from the actual velocity to rest at the rate defined by `SPEEDREFDECELTIME` (unless `SPEEDREFSOURCE` is set to 1 - see the help file) and keep the reached position in controlled manner. The function is independent of the actual operating mode (current- or velocity mode). This function can both be activated by hardware input DIN 2 (X3.12), the DIP-switch AS1.5 or by software.

"QUIT": If the input is activated the current positioning process will be aborted. A restart (trigger) is required in order to continue the positioning after the quit input has been reset to zero

"DIN x": There are up to 4 machine inputs available. Inputs X3.16 (DIN 6) and X3.17 (DIN 7) can either be used together with the PLC program (default) or for selection of the programmed point-to-point move. If more than three programmed point-to-point moves are needed, the alternative functions of the inputs X3.10 (DIN 0) and/or X3.11 (DIN 1) must be used. **Please note**, that the limit switch function is not available in this case. To substitute (or add-on) the function of the hardware limit switches, software limit switches can be defined.

"FRESET": If the input is activated, the drive will attempt to cancel all types of error and then re-enable.

"HOMEINPUT": (Position Control) This input is for determination of the home position. It is an edge-controlled input and the input function can be activated by a rising or falling signal edge.

"PRESETTRIGGERINPUT": (Position Control) With this input a programmed point-to-point move will be started. If the input will be activated, the position move addressed with the Mal's will be executed. It is an (rising) edge controlled input.

Preset timing diagram:

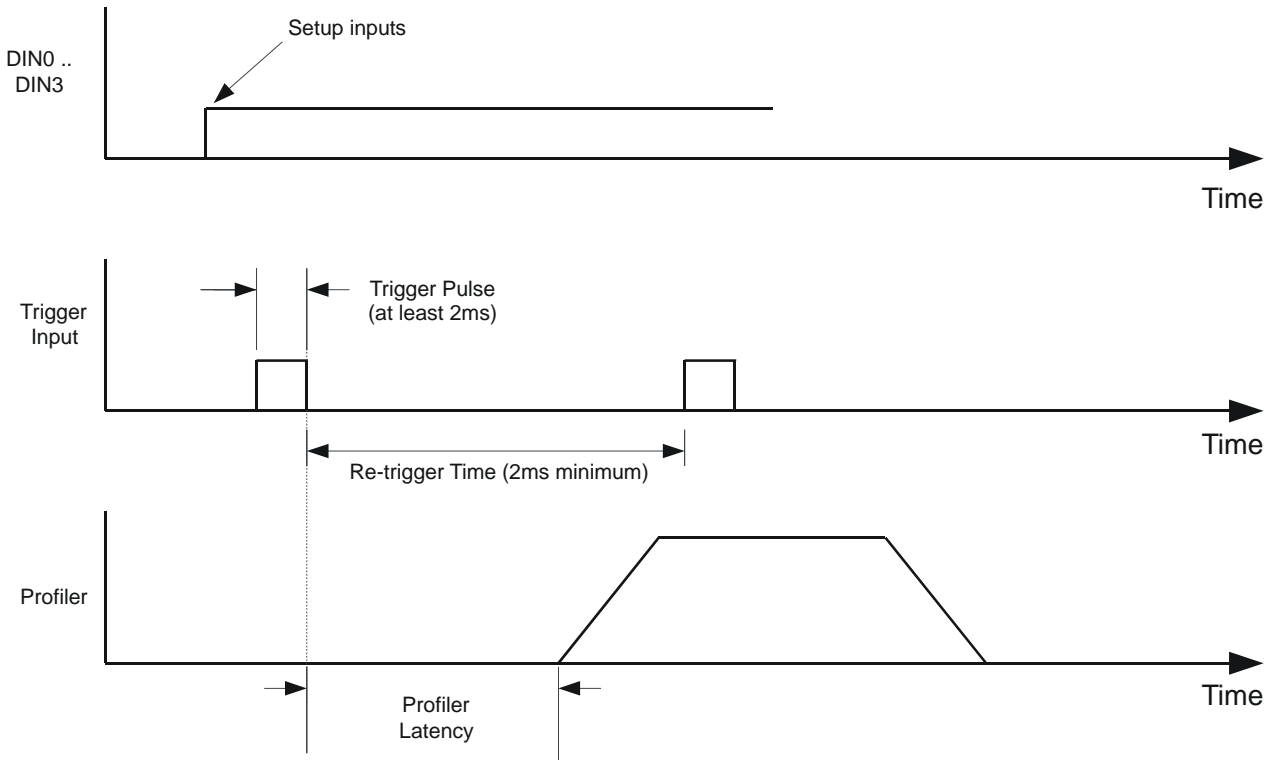

Functional example of control inputs:

The wiring of the control inputs is also shown in chapter 4.3 .

The picture on the right hand side shows the function and the two wiring principles of the control inputs:

The two wiring versions are:

- 1) Switching to the external control input power supply. The switch will be linked between the control input (X3.x) and the external power supply (V_{ext}). The ground return (GND_{ext}) is permanently wired with CREF (X3.7).
- 2) Switch to the ground return of the external power supply. The switch will be linked between the control input and the external ground return (GND_{ext}). The external power supply (V_{ext}) is permanently wired with CREF (X3.7).

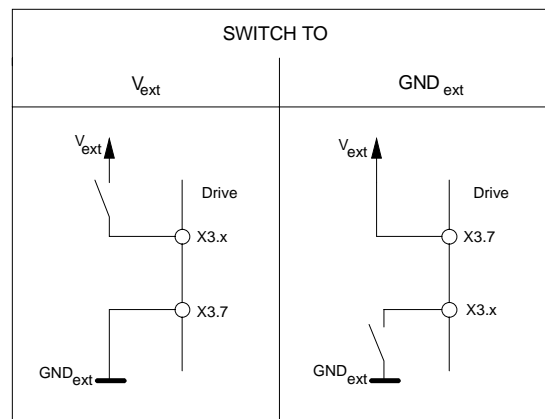

X3.x: "x" for connector pin,
e.g. x=9 → X3.9 = Enable-Input

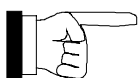

The control inputs only operate, if they are supplied with an external voltage.

Control Input Wiring:

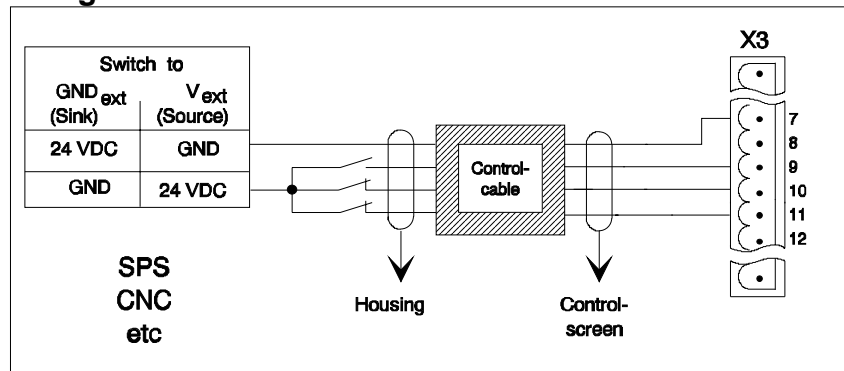

4.2.2 Control Outputs

The control outputs must be supplied with an external voltage. The wiring of the control outputs is optional and not necessary for proper drive operation.

Control Output Function:

Signal name	Connector Pin	Switch Position / Function	
		active / closed	not active / open
FAULT+	X3.4	Controller happy - no fault	Controller not happy - drive fault
FAULT -	X3.5		
DOUT 0	X3.18	Digital output 0 = logical 1	Digital output 0 = logical 0
DOUT 1	X3.19	Digital output 1 = logical 1	Digital output 1 = logical 0
DOUT 2, DrOK	X3.20	Digital output 2 = active - no fault	Digital output 2 not active = drive fault

More about control outputs:

"FAULT": This output is a relay contact and consists of two connector pins. It indicates the general drive status.



The FAULT relay contact is not suitable for switching inductive loads (relays). Inductive loads can cause some nuisance drive faults.

"DrOK": This output has the same functionality than the fault relay output. The output (+24V) is activated in case the drive is ready for work.

"DOUT x": These outputs can be used together with the drive internal PLC program. There are 2 digital outputs available.

Control Output Wiring:

The control outputs can be wired like shown below. Chapter 7 shows the hardware circuits of the outputs. All outputs are active "HIGH" (source) and referred to CGND (X3.8).

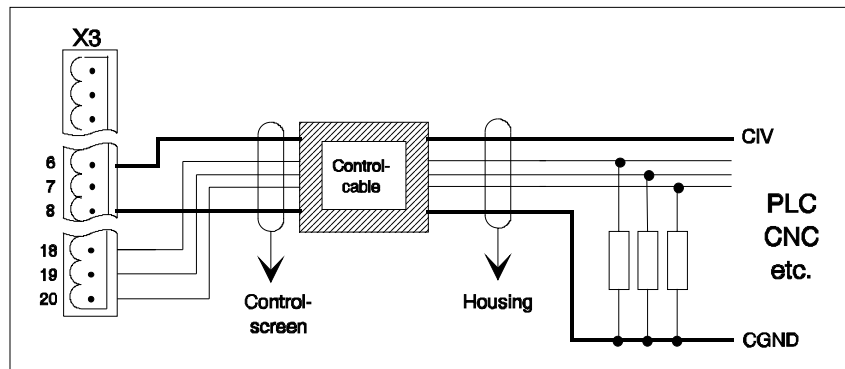

4.2.3 Resolver (optional)

The resolver must be wired to drive connector X8 and on the motor side with signal connector.

Wiring of the resolver in- and outputs:

The wiring is shown in chapter 4.3.
Maximum cable length is 25m

SIGNAL Connector - Pin	COLOUR CODE	
	Standard- Resolver cable	Cable Exit BSM1R
REF + / X8 - 1	red	red / white
REF - / X8 - 6	blue	yellow / white
COS + / X8 - 2	green	red
COS - / X8 - 7	yellow	black
SIN + / X8 - 3	pink	yellow
SIN - / X8 - 8	grey	grey

All cables have to be screened.[3x(2x0,14mm²)]

4.2.4 Encoder Output

The controller has an encoder output (X7), which can be used for position- and/or velocity feedback for a superset controller. The encoder output resolution (*pulse per revolution*; ppr) can be configured via software. The following resolutions are available; using resolver feedback

512ppr

1024ppr

2048ppr²⁾

4096ppr²⁾

²⁾ only available if feedback is set to 4096 using the ENCODERLINESOUT keyword.

In case Hiperface-encoder feedback is used the output (X7) corresponds to the physical encoder resolution multiplied by 4 (ex. 1024ppr x 4)

Wiring of the encoder output:

A wiring proposal is shown in chapter 4.3.

It is strongly recommended to make the wire connection with a twisted and screened cable.

4.2.5 Master Encoder Input (X9)

Handwheel Mode

The controller can be configured as slave device from a handwheel encoder. The ratio between incoming encoder signals and the motor speed is configurable via software.

Wiring of the encoder input:

The connector X9 must be wired according to the interconnection diagram (see chapter 3.1).

4.2.6 Command Input

The drive has an analog command input ($\pm 10V$). The input can be wired in "single-ended" or in "differential mode".

Wiring of the command input:

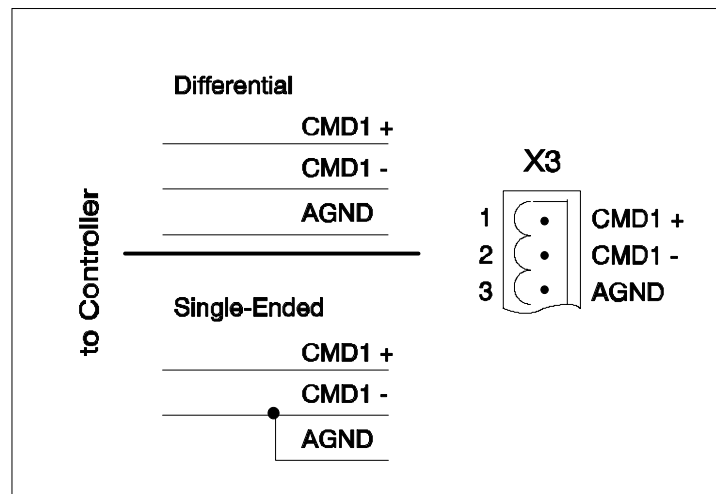

4.2.7 Interface Cables

The bit-rate for communication is 57600 baud (factory preset). Other bit-rates are possible. To prevent interference it is advised to keep cable length at 3m or less. Shielding interface cables is highly recommended. It is also advised not to run the interface cable next to high power or AC signals such as servo amplifiers, line voltages etc.

The wiring from PC to drive connector X6 for serial interface must be as shown below:

A) RS232

RS232 is the standard interface.

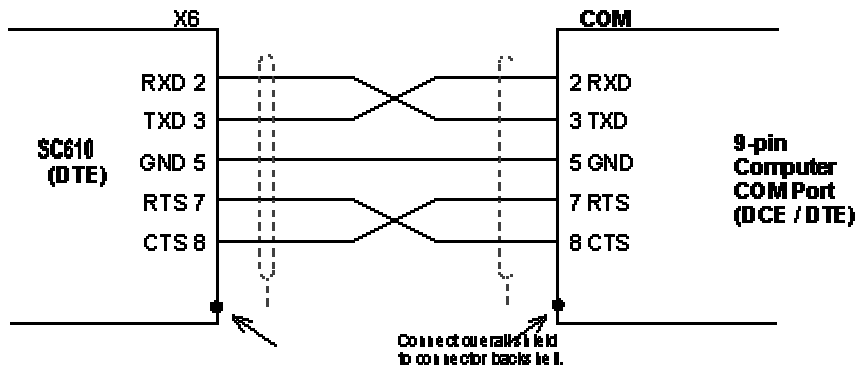

CAUTION:

The serial connector on the SC610 (X6) can be configured as either RS232 or RS422 / RS485. Pin 9 is used to carry +8V for powering certain keypad peripherals. Ensure that pin 9 is not connected to ground or to equipment that could be damaged by the +8V supply

B) RS485

The RS485 is an optional interface only and must be adjusted via DIP switch AS1.10. For further information concerning multi-drop applications please refer to appendix D.

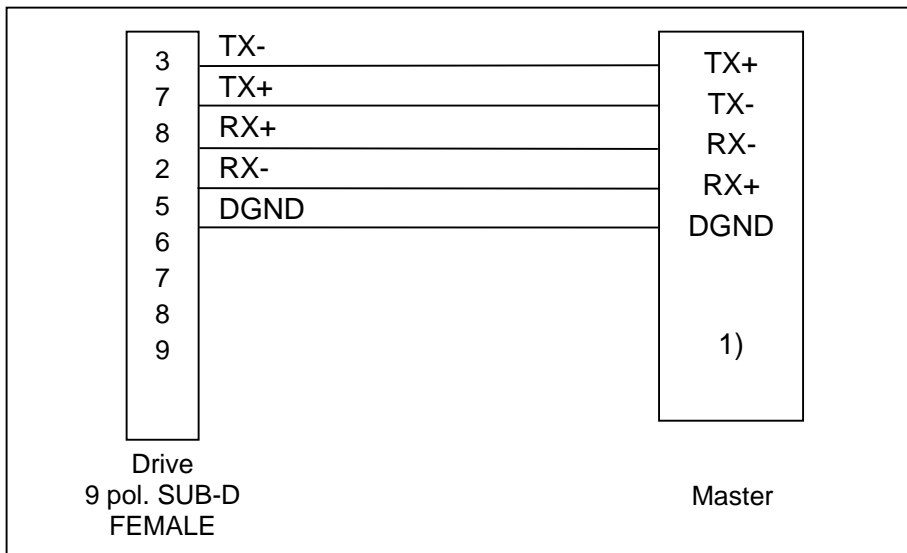

1) Wiring principle at the master may be different than shown above. Please refer to the interface description of your master system.

4.3 Minimum Wiring Diagram

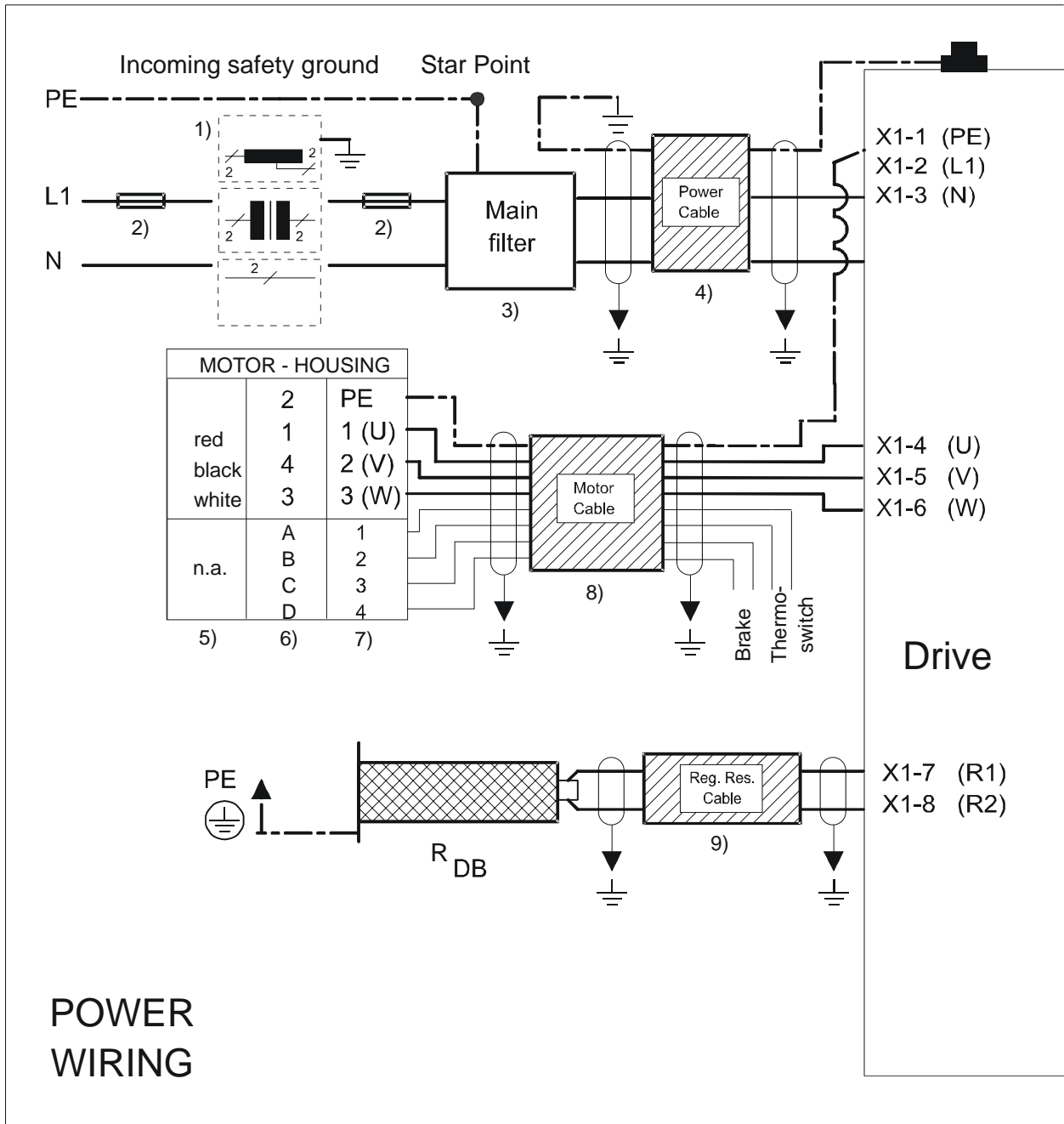

- 1) Main Power (Autotransformer, Isolating transformer, 1 phase connection; see also chapter 4.1.1)
- 2) Fuses (see also chapter 4.1.1)
- 3) Main Filter (see also chapter 4.1.2 and appendix A)
- 4) Power cable not available from Harmonic Drive. Lead diameter must fit to the transformer and drive.
- 5) Flying leads FHA- RS-series
- 6) Connector BSM50/63/80
- 7) Not valid
- 8) Motor cable (see also chapter 4.1.3)
- 9) Sizing and further wiring recommendations see chapter 4.1.5.

Encoder-Feedback

Encoder-FHA-A/B

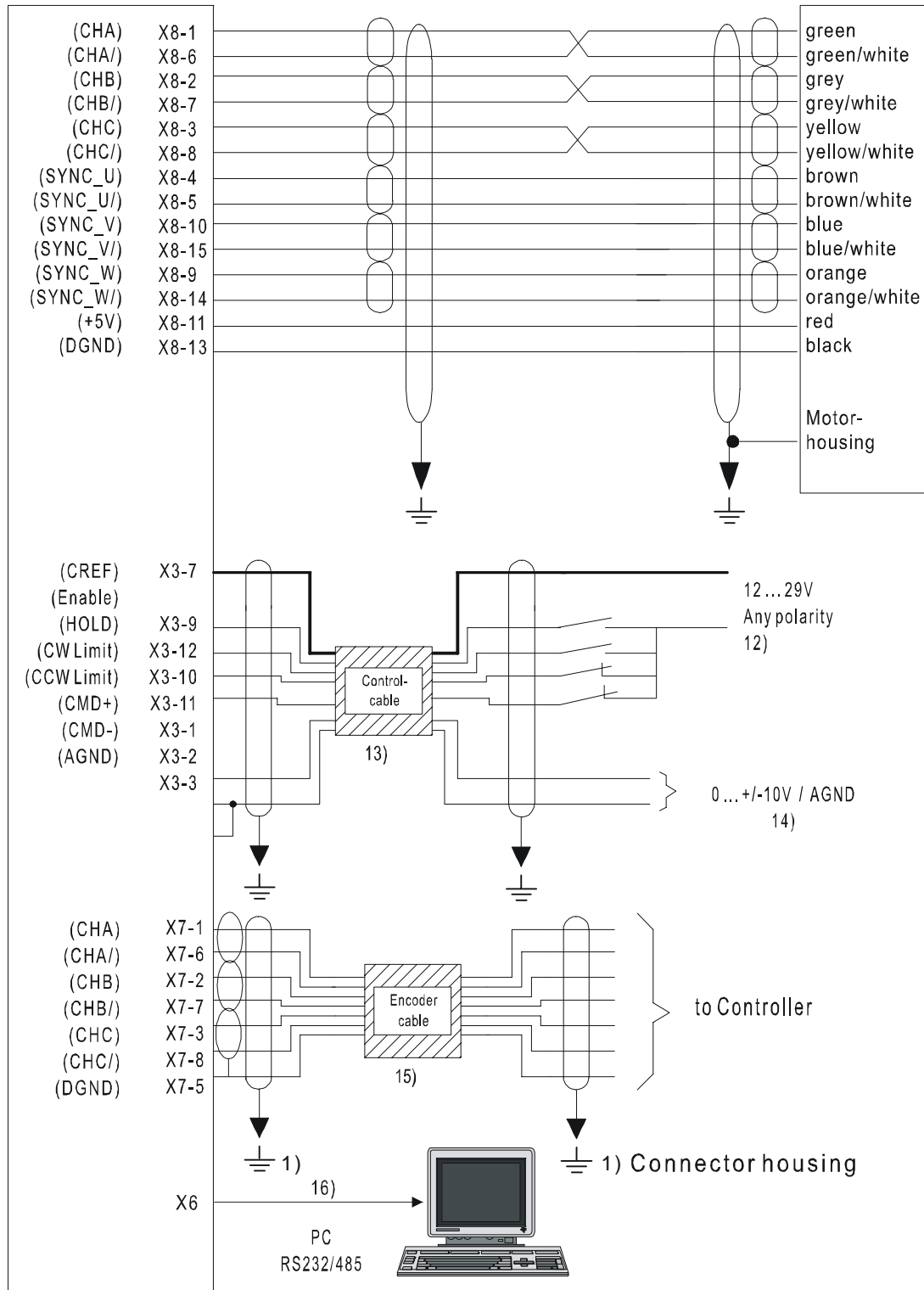

Please refer to appendix A in order to achieve the wiring according to the EMC regulations



CW Limit and CCW Limit: Please note that servo axes incorporating Harmonic Drive gears (i. e. FHA-, CHA-, FFA- and RS-C-series) will be effected by a change of the turning direction. In this case CW- and CCW-limit have to be cross wired.

Hiperface-Feedback

Encoder-FHA-C/CHA

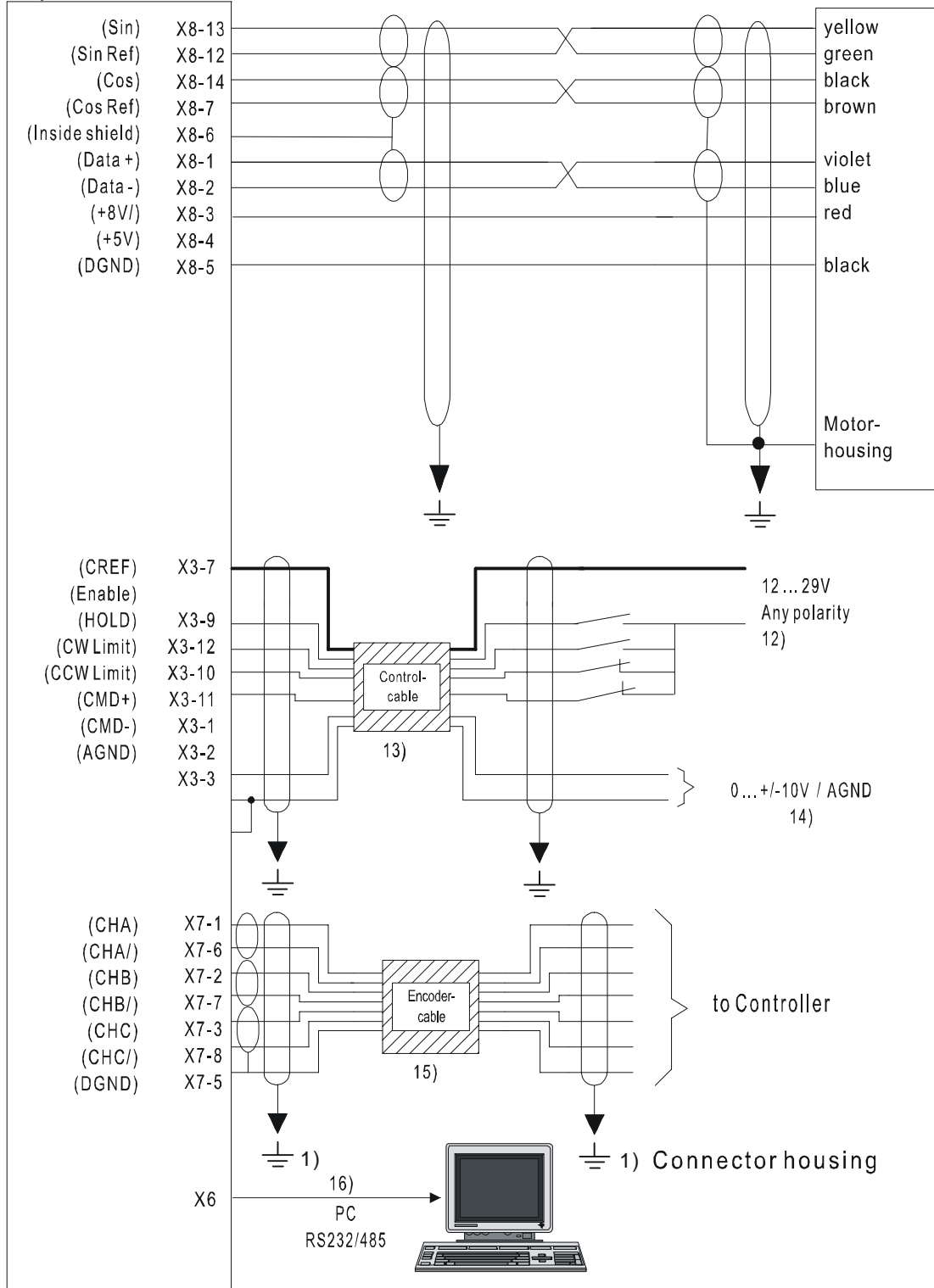

Please refer to appendix A in order to achieve the wiring according to the EMC regulations



CW Limit and CCW Limit: Please note that servo axes incorporating Harmonic Drive gears (i. e. FHA-, CHA-, FFA-and RS-series) will be effected by a change of the turning direction. In this case CW- and CCW-limit have to be cross wired.

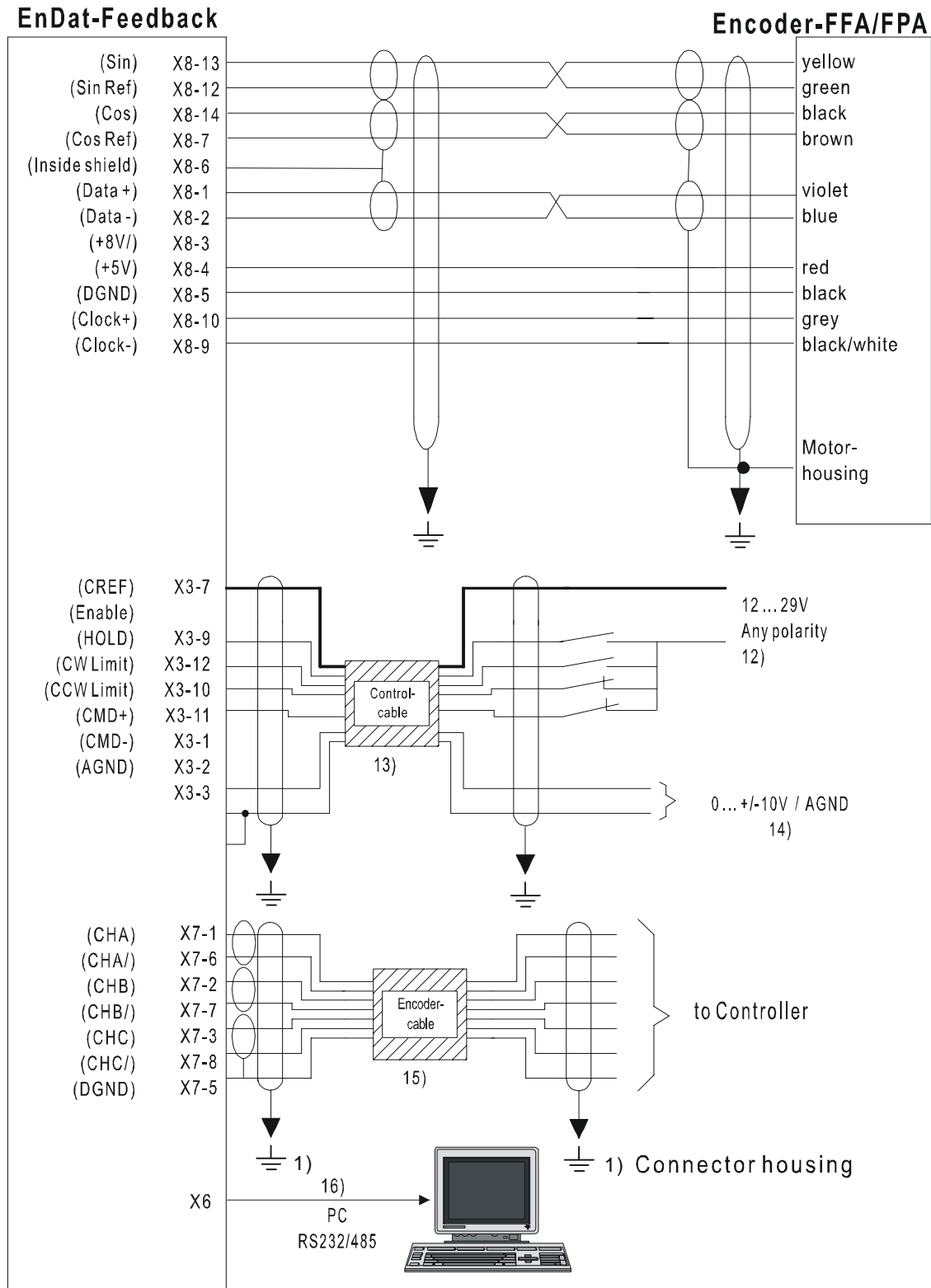

Please refer to appendix A in order to achieve the wiring according to the EMC regulations



CW Limit and CCW Limit: Please note that servo axes incorporating Harmonic Drive gears (i. e. FHA-, CHA-, FFA-and RS-C-series) will be effected by a change of the turning direction. In this case CW- and CCW-limit have to be cross wired.

Encoder-Feedback

Encoder-FHA-A/B

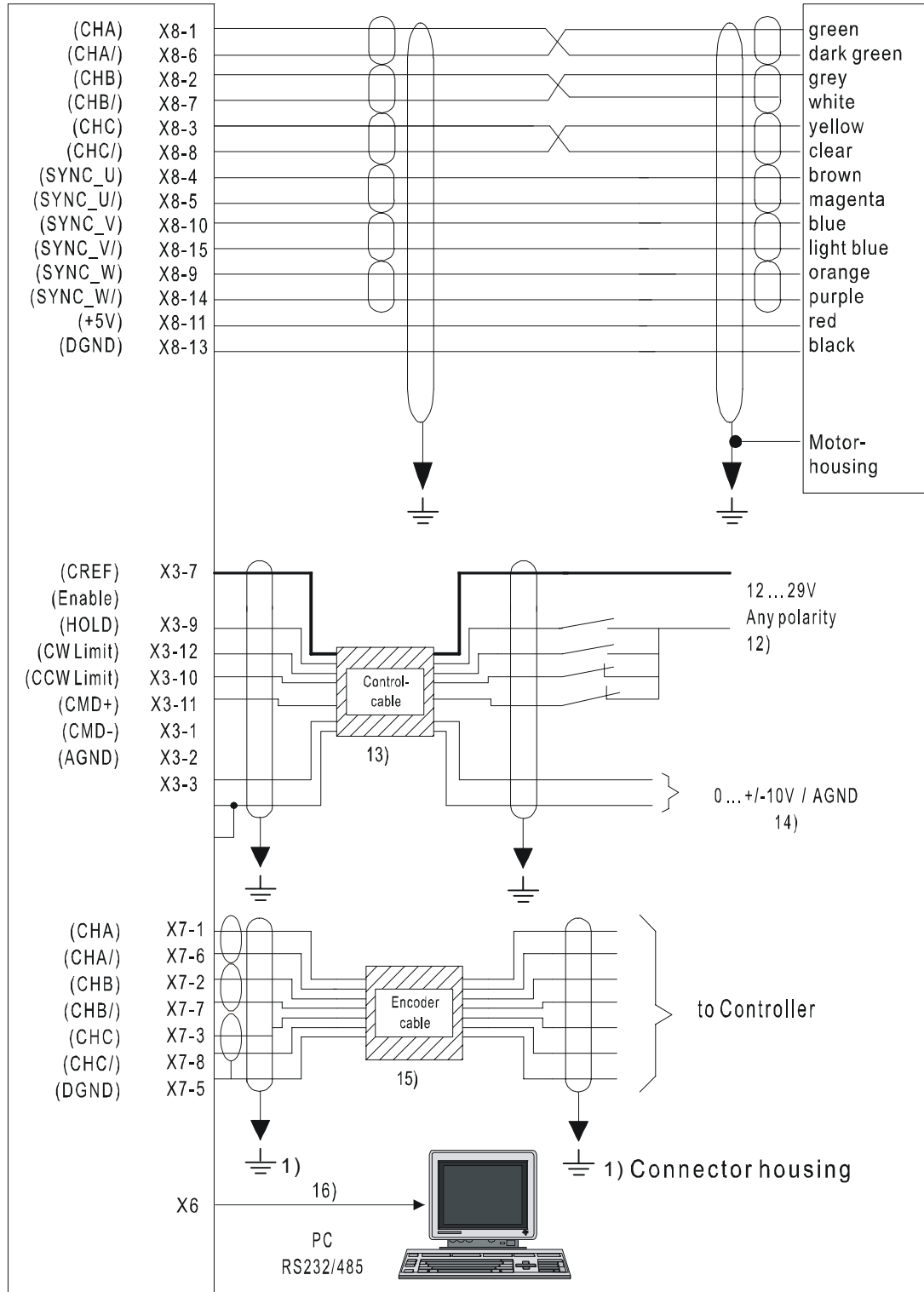

Please refer to appendix A in order to achieve the wiring according to the EMC regulations



CW Limit and CCW Limit: Please note that servo axes incorporating Harmonic Drive gears (i. e. FHA-, CHA-, FFA- and RS-C-series) will be effected by a change of the turning direction. In this case CW- and CCW-limit have to be cross wired.

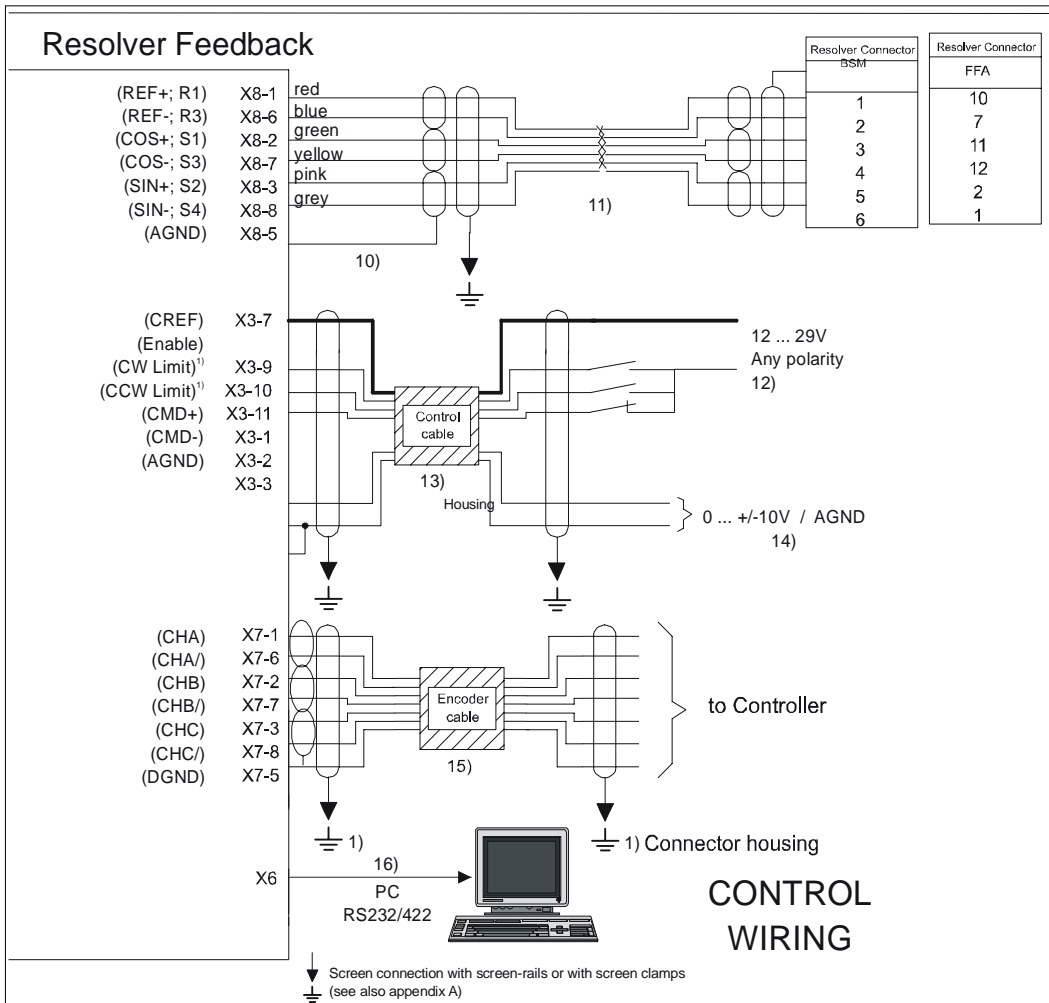

- 10)** If a very strong affect of EMI will be expected, it is recommended to connect the inside screens to AGND.
- 11)** Resolver cable; BSM1R has flying leads
- 12)** Functional description of the control inputs see chapter 4.2.1. The control inputs must be supplied with an external voltage source.
- 13)** The Control cable is not available from Harmonic Drive. Drawing shows the wiring principle only. Can be one or more cables.
NOTE: DGND and AGND are internally linked together. If the used controller does **not** have two independent grounds, only one GND should be wired to the controller to avoid ground-loops.
- 14)** If the wiring is done like shown in the drawing, the motor rotates clock wise (view at motor shaft) with a positive voltage on X3.1 referenced to X3.2.
- 15)** Encoder cable, twisted and screened
- 16)** Interface cable refer to 4.2.7

ATTENTION: Please note also chapters 4.0. to 4.2. and Appendix A

- 1) Please note that servo axes incorporating Harmonic Drive gears (i. e. FHA-, CHA-, FFA- and RS-C-series) will be effected by a change of the turning direction. In this case CW- and CCW-limit have to be cross wired.

5.0 System Set Up Procedure

5.1 Presets

Before applying power to the system, the following settings must be checked.

DIP - Switches: Settings and Functions

The pictures show

- A) settings ex factory (all DIP-switches "OFF") and
- B) operating status (DIP-switch AS1.8 "ON")

of the DIP-switches.

A) Setting ex factory

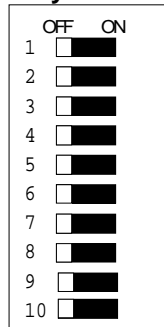

B) Operating status

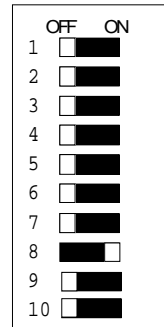

Note: For first time installation always make sure that all DIP-switches are in "OFF" position (see picture A) until motor and drive parameters are downloaded.

Card Address Setting / DIP-Switch AS1.1-4 (Multi-Drop Application)

Each card's address can be set-up by setting the DIP switch on the card as follows:

AS1.1	AS1.2	AS1.3	AS1.4	Card-Address (Node number)
OFF	OFF	OFF	OFF	Will be determined by Mint Keyword "Node"
OFF	OFF	OFF	ON	1
OFF	OFF	ON	OFF	2
OFF	OFF	ON	ON	3
OFF	ON	OFF	OFF	4
ON	ON	OFF	ON	5
OFF	ON	ON	OFF	6
OFF	ON	ON	ON	7
ON	OFF	OFF	OFF	8
ON	OFF	OFF	ON	9
ON	OFF	ON	OFF	10 (hex a)
ON	OFF	ON	ON	11 (hex b)
ON	ON	OFF	OFF	12 (hex c)
ON	ON	OFF	ON	13 (hex d)
ON	ON	ON	OFF	14 (hex e)
ON	ON	ON	ON	Attention: Reset to "Factory Defaults"

Setting / Function DIP - Switch AS1.5 - 10

DIP-Switch AS1.	Function	Switch Setting	
		ON	OFF *)
5	Hold - Position	Hold - Position is active	Hold - Position is not active
6	Terminal resistor for RS485	Activate resistor	Deactivate resistor
7	automatic offset tuning	automatic offset-tuning is active	automatic offset-tuning is not active
8	ENABLE	amplifier enabled (active)	amplifier disabled (not active)
9	reserved		
10	Communication port selection	RS485	RS232

*) ex factory

Further explanations to AS1.5, 7, 8:

- AS1.5:** If switch is "ON" the motor will decelerate from the actual velocity to rest at the rate defined by `SPEEDREFDECELTIME` and keep the reached position in controlled manner. The function is independent of the actual operating mode (current, velocity or position mode). Hold-Position function can also be activated by hardware input STOP (X3.12) or by the setup-software.
- AS1.7:** If switch is "ON" an automatic offset tuning will be executed if DIP-switch AS8 is changed from ON to OFF. The purpose of the offset compensation is to cancel offsets on the line. Therefore it is important to set the analog command to zero. It is recommended to leave this switch at "OFF" during normal operation.

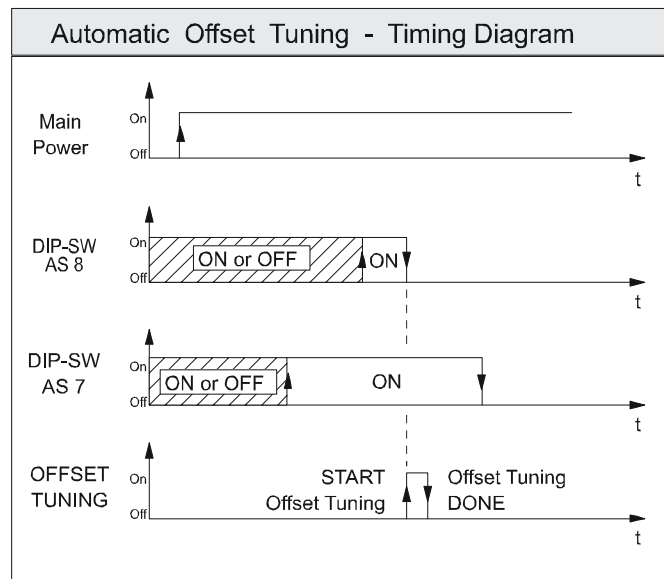

- AS1.8:** In switch position "OFF" the amplifier will be disabled. The function is the same as hardware enable-input (X3.9) and software command "DRIVEENABLE".

5.2 System Set Up Step by Step

With all initial settings completed (chapter 5.1), the set-up procedure can begin.



Please perform the initial set-up of the system with no load applied to avoid damaging your equipment due to unexpected movement.

1. Connect your system only to the main power as shown in drawings chapter 4. When using a transformer, check the secondary voltage of the transformer. Please refer to the transformer specification.



After the measurements disconnect the transformer from the power.

2. Now you can wire the drive under observance of chapter 4. System must be idle. It is **not** advised to connect the motor cable yet. On the other hand the measuring system (Encoder/Resolver) **must** be connected to the drive. Don't close the ENABLE switch (X3.9).



An external 24VDC power supply must be connected to the drive, if you have the 24V-option.

3. Install the connection between PC and the controller with the interface cable. Make sure that the enable input (X3.9) is not activated (switch opened or no wiring). Now turn *ON* the main power. After power on, the LED will show the following state:

LED "DB ON" = *OFF*

After power on procedure the monitor will show the final state:

Status = Status will show " - " only; decimal point lower right corner must be *OFF*. (If status display is showing 8, the amplifier is enabled. To disable the amplifier check enable-input (X3.9)).

Configure the controller with the help of the WorkBench v5 software and then turn *OFF* main power. Please note at this time, that every drive is pre-configured ex factory and basically ready to operate. Please refer also to motor-drive-assignment according to appendix F.



After turning off the power supply, wait about 5 min. to allow discharging of the capacitors inside the main power supply.

4. Now connect the motor cable. Turn *ON* main power again and activate the enable input (X3.9); close the switch (see chapter 4). After that the monitor will show the following operating state:

Status = " - "

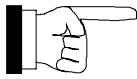

Random power on sequence for 24V resp. bus supply.

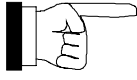

If the motor develops no torque and
...monitor shows a \uparrow . or \downarrow . check the wiring of CW and
CCW-limits (X3-10; X3-11)
or
... monitor shows a " - " check ENABLE input (X3-9) and
DIP switch AS 1.8.

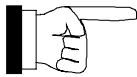

If the motor shaft accelerates, turn off the power immediately
and check the motor and measuring system.

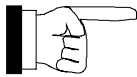

If the decimal point on the monitor does not appear, check the
wiring of X3-9 (ENABLE) and DIP-Switch AS1.8.

5. Now you are ready to perform the system tuning. Please tune the drive only in case the performance concerning accuracy and response is not satisfactory!

6.0 Status Indicators

6.1 Status Monitor

The controller provides a status monitor. The indicated signs have the following meaning:
For further monitor indications, please refer to appendix C.

0.	Drive / comms watchdog. Interprocessor communications failure. This is potentially a severe problem if it occurs repeatedly. Communications failure could indicate a process locking out the interprocessor communications. Clear the error; if the problem persists then contact technical support.
1.	Over volts. The DC Bus voltage has exceeded the powerbase overvolts level (see DRIVEBUSOVERVOLTS). Check the DC Bus level being fed into the system (see Mint keyword DRIVEBUSVOLTS). This should be close to the nominal voltage (see Mint keyword DRIVEBUSNOMINALVOLTS). Ensure that your input voltage is relevant to the voltage rating of your drive. If the input voltage is correct, then this error may be the result of high deceleration rates. If it is not possible to reduce the harshness of the deceleration rate, then a regeneration resistor should be used. To help you, use WorkBench v5 capture facility to monitor the DC Bus level during moves.
2.	Integrated Power Module (IPM) trip. The unit's powerbase has been overloaded. This should not happen in normal use if limits have been configured correctly. See the Mint keyword CURRENTLIMIT and related commands.
3.	Current trip. Instantaneous over-current trip. One or more of the 3 motor phases has exceeded 300% of Drive Rated Current.
4.	Under volts. The DC Bus voltage has dropped below the powerbase undervolts level (see DRIVEBUSUNDERVOLTS). This error will only be generated if the drive is in the enabled state. As with the overvolts error, check the input voltage being fed into the system. The error could also occur during high acceleration profiles.
5.	Feedback trip. Can be enabled/disabled using FEEDBACKFAULTENABLE. Five consecutive errors (or five errors in any 500 servo tick period) will cause the drive to trip. This error indicates loss of encoder/resolver feedback and may indicate that the feedback cable has become detached or one of the signals has broken. Check the wiring in the Feedback cable; check for noise immunity; check the feedback device fitted to the motor (if possible).
6.	Motor or Drive trip. The motor I ² T or the drive I.T current protection algorithms have exceeded their limit and tripped the drive (disabled it). Check DRIVEERROR or the Error Log to determine which error has occurred. The motor and drive current limits are fixed according to the database parameters. The drive can demand peak current for a short duration (see DRIVEPEAKDURATION), thereafter it will trip or Foldback according to the setting of DRIVEOVERLOADMODE. The same is true for the motor (see MOTORPEAKDURATION and MOTOROVERLOADAREA). Use the Foldback option to automatically foldback the current to a level where the drive/motor can recover.
7	(Symbol not flashing) Motor I ² T / It foldback. Motor I ² T or Drive I.T algorithm has resulted in the demand current being folded back to a level where the drive/motor can recover. The motor / drive can run with demand currents greater than their rated value for a period of time; after that time the drive will either trip or automatically foldback the demand current.
7.	Overtemperature. The temperature of the drive or motor has exceeded a trip level (see Mint keyword TEMPERATURELIMITFATAL) or the Motor overtemperature trip input has been activated (see Mint keyword MOTORTEMPERATUREINPUT).
8	Drive enabled. The drive is enabled (except where CONFIG = _cfVirtual, where it is not physically enabled).
9	Torque mode. The drive is in Torque mode. See the Mint keywords TORQUE, TORQUERESOURCE and related commands.
8	Auto tune test driving motor. Autotune is active and driving the motor. The motor may move.
E.	General error. See AXISERROR and DRIVEERROR. The motion toolbar displays the status of AXISERROR, which is a bit pattern of all latched errors. See also the <i>Error Log</i> topics in the help file.
E.	Error input. The ERRORINPUT has been activated and generated an error.

F .	Position or velocity following error. A following error has occurred. See the Mint keyword <code>AXISError</code> and associated keywords. Following errors could be caused by a badly tuned drive/motor. At higher acceleration and deceleration rates, the following error will typically be greater. Ensure that the drive/motor is adequately tuned to cope with these acceleration rates. The following error limit can be adjusted to suite your application (see Mint keywords <code>FOLERRORFATAL</code> and <code>VELFATAL</code>). Following error could also be the cause of encoder/resolver loss (see also Mint keyword <code>FEEDBACKFAULTENABLE</code>).
F	Follow mode. The drive is in Follow mode. See the Mint keyword <code>FOLLOW</code> .
H	Hold. The Hold DIP switch is active or the PLC Task has requested a Hold state. Motion will be ramped to zero demand and will then hold on position while the switch is active.
h	Homing. The drive is currently homing. See the Mint keyword <code>HOME</code> .
h .	Preset Homing. The drive is currently homing. This motion has been triggered from a Preset move table.
I	Incremental move. An incremental move is being profiled. See the Mint keywords <code>INCA</code> and <code>INCR</code> .
J	Jog. The drive is jogging. In the Mint help file, see the topics <code>JOG</code> , <code>JOGCOMMAND</code> and <i>Jog screen</i> .
J .	Preset jog. The drive is jogging. The jog was triggered from a Preset jog table.
O .	Overspeed. The measured speed of the motor has exceeded the trip level defined by <code>DRIVESPEEDFATAL</code> . Check that the trip level is set to a suitable value for your application. When accelerating to a demand speed close to the trip level, there will typically be a certain amount of overshoot. Using the Fine-tuning tool, check the amount of overshoot you get with the acceleration and demand speeds being used in your application.
P	Positional Move. The drive is performing a linear move. See the Mint keywords <code>MOVEA</code> and <code>MOVER</code> .
P .	Preset positions. The drive is performing a linear move. This motion has been triggered from a Preset move table.
S	Stop. A <code>STOP</code> command has been issued or the stop input is active.
-	Drive disabled. The drive must be enabled before operation can continue. Click the Drive enable button in WorkBench v5.
-.	Crash (various). The drive enable input or the Enable DIP switch have become inactive whilst the drive was in the enable state (or the drive was enabled whilst they were inactive) - bit 13 in <code>AXISError</code> will be set. The drive can be programmed to ignore this state using the Mint keyword <code>DRIVEENABLEINPUTMODE</code> (see the Parameters tool).
-	Suspend. The <code>SUSPEND</code> command has been issued and is active. Motion will be ramped to zero demand whilst active.
S	Speed demand. The drive is under speed control. See the Mint keywords <code>SPEEDREF</code> , <code>SPEEDREFSOURCE</code> and related commands.
S	(Reserved)
L .	Reverse software or hardware limit. A reverse software limit has been activated. See <code>AXISError</code> and/or <code>AXISSTATUS</code> to determine which applies.
F .	Forward software or hardware limit. A forward software limit has been activated. See <code>AXISError</code> and/or <code>AXISSTATUS</code> to determine which applies.
≡	Firmware being updated (horizontal bars appear sequentially). New firmware is being downloaded to the drive.
i .	Initialization error. An initialization error has occurred at power on. See the <i>Error Log</i> or <code>INITERROR</code> and <code>INITWARNING</code> topics in the help file. Initialization errors should not normally occur. (possible reasons: Encoder feedback corrupt or 8V fuse of drive damaged X8.3/ X8.5)
-.	Bar is illuminated permanently, dot right corner is flashing: Crash, i.e. interrupt during Firmware-Download, no communication with the controller possible. Counter measure: Open software WORK BENCH, start SCAN-procedure and stop it directly afterwards. The screen shows „No Controller found“. The SELECT Button turn into UPDATE FIRMWARE. Download the firmware again via this button.

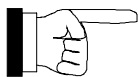

For drives with 24V-option the status monitor works only if the 24V is switched on.

6.2 LED Regeneration Load

This LED located on the front panel indicates the activity of the regeneration. During regenerative actions this LED will illuminate "YELLOW". This means, power will be dissipated into the regeneration resistor.

7.0 I/O Hardware Description

- Legend:

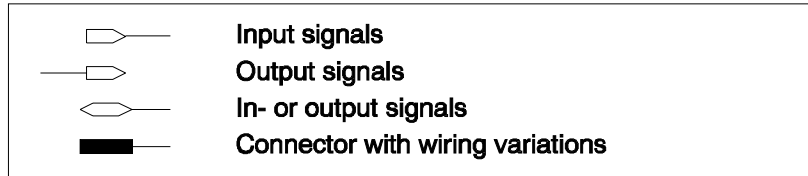

7.1 Input Signals

Digital Inputs Connector X3 (not valid for DIN4 and DIN5)			
Function	Signal	PIN	Hardware
Enable	ENABLE	9	<p>- Low Active:</p> <p>- High Active:</p> <p>min. Input Impedance $R_{IN} = 4.7k\Omega$; opto coupled; $U_{IN} = 12 \dots 29V_{DC}$; Delay time $T_d = 60\mu s$ max. current at 24V: $I = 5.2mA$</p>
DIN 0	CWLimit (position select)	10	
DIN 1	CCWLimit (position select)	11	
DIN 2	HOLD (QUIT)	12	
DIN 3	FRESET	13	
DIN 6	Position Select	16	
DIN 7	Position Select	17	
Ground Return	CREF	7	

Functions in () are only valid for Position Control mode.

ATTENTION: Drives with I/O-Expansion (Connector X12 assembled) require the position selection and trigger input to be used on X12! Please refer to chapter 7.6

Fast Inputs Connector X3 only valid for DIN4 and DIN5			
Function	Signal	PIN	Hardware
DIN 4	PULSE (HOME FLAG)	14	<p>min. Input Impedance $R_{IN} = 4.7k\Omega$; opto coupled; $U_{IN} = 12 \dots 29V_{DC}$; Delay time $T_D = 60\mu s$ max. current at 24V: $I = 5.2mA$</p>
DIN 5	DIRECTION (TRIGGER)	15	
Ground Return	GREF	7	

Advices for wiring DIN4 and DIN5:

- Shielded and twisted pair cables have to be used in order to avoid disturbance caused by electric interference.
- Mechanical switches, relay contacts or other sources liable to signal 'bounce' should not be connected directly to these fast inputs. This could cause unwanted multiple triggering.

Analog Input Connector X3			
Function	Signal	PIN	Hardware
Velocity- or Current- Command	CMD+ CMD- AGND	1 2 3	<p style="text-align: right;">$U_{cmd} = \pm 10V_{DC}$</p>

7.2 Output Signals

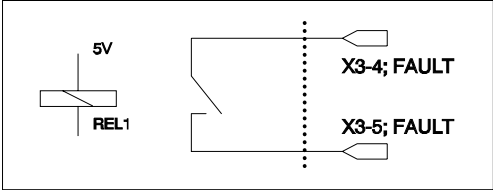
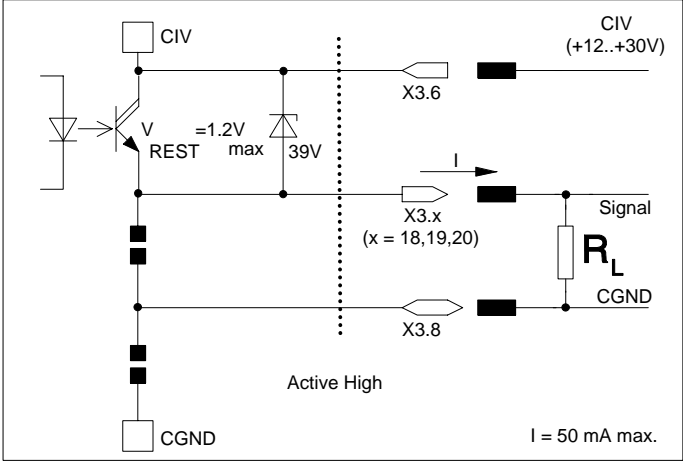
Digital Outputs Connector X3			
Function	Signal	PIN	Hardware
Fault Relay	FAULT REL.	4	 <p>Contact is closed, if system works correct $U_{AC} = 125V$ $I_{max} = 0.5A$ $U_{DC} = 30V$ $I_{max} = 2A$</p>
	FAULT REL.	5	
DOUT 0	General Purpose	18	 <p>Active High $I = 50 \text{ mA max.}$</p>
DOUT 1	General Purpose	19	
DOUT 2, Drive OK	DrOK	20	
Customer Interface Voltage	CIV	6	
Ground Return	CGND	8	

7.3 Resolver X8

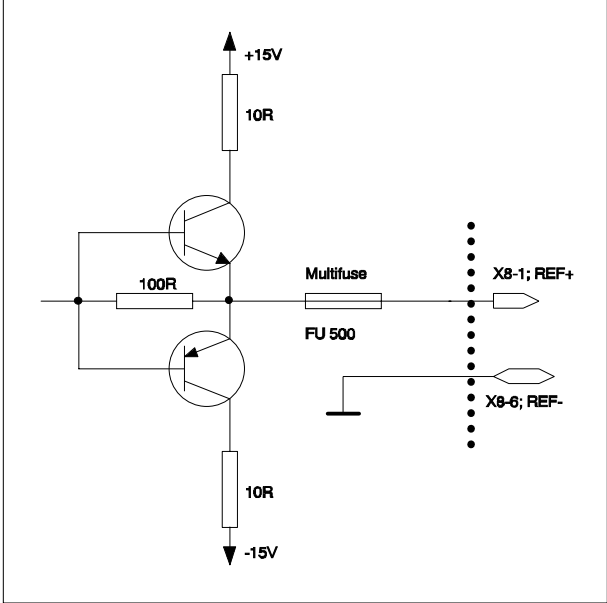
Resolver Signals Connector X8			
Function	Signal	PIN	Hardware
Reference Signal	REF +	1	 <p>Signal waveform sinusoidal; $f = 7.2 \dots 8.0\text{kHz}$; $17.0V_{pp} \pm 5\%$ + 0 .. 0.4 VDC; $I_{peak} = 0.2A$; short circuit proof</p>
	REF -	6	

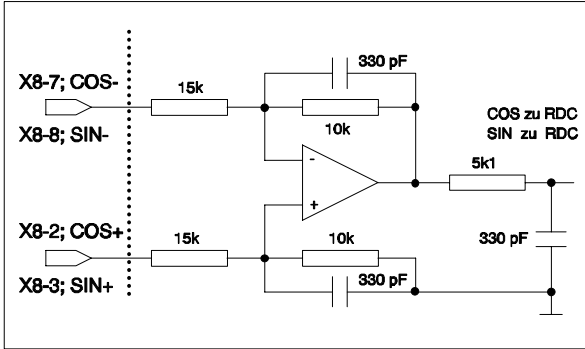
Resolver Signals Connector X8			
Function	Signal	PIN	Hardware
COSINE Input	Cos+	2	 <p>Signal waveform sinusoidal; $U_{IN} = 0 \dots 10V_{pp} + 0 \dots 0,4VDC$; 7.2 .. 8.0kHz</p>
	SINE Input	Sin+ Sin-	

7.4 Encoder Output X7

Encoder Signals Connector X7			
Function	Signal	PIN	Hardware
Encoder Channel_A	CHA CHA /	1 6	<p>I/O-standard RS422 TTL-Signal;</p>
Encoder Channel_B	CHB CHB /	2 7	
Encoder Channel_C	CHC CHC /	3 8	

7.5 Encoder X8 (HIPERFACE/ EnDat)

Encoder Signals Connector X8			
Function	Signal	PIN	Hardware
Parameter + Parameter -	Data + Data -	1 2	
Cosine CosReference	Cos CosRef -	14 7	
Sinus SinReference	Sin SinRef	13 12	
Power supply Power supply	+8V +5V	3 4	
Clock - Clock +	Clock - Clock +	9 10	
Reference Reference	R - R +	8 15	
Ground return Ground return Shield	DGND DGND Shield	5 11 6	

7.6 Encoder X8 (TTL-Encoder)

Encoder Signals Connector X8			
Function	Signal	PIN	Hardware
Encoder Channel A	CHA CHA/	1 6	
Encoder Channel B	CHB CHB/	2 7	
Encoder Channel C	CHC CHC/	3 8	
Hall Input U and U/	— SYNC_U SYNC_U /	4 5	
Hall Input V and V/	— SYNC_V SYNC_V /	10 15	
Hall Input W and W/	— SYNC_W SYNC_W /	9 14	
Power Supply Reference	— + 5V DGND	11 13	I/O-Standard RS422 TTL-Signal; (f < 125kHz) @ 350 mA

7.7 SC-610-I/O-Expansion for 256 pre-set positions X12

Signal name	Connector Pin	Switch position / Function	
		closed	open
ENABLE	X3.9	Controller enabled	Controller disabled
Ma1 3 (DIN 0)	X3.10	Machine Input 3 = logical 1	Machine Input 3 = logical 0
Ma1 4 (DIN 1)	X3.11	Machine Input 4 = logical 1	Machine Input 4 = logical 0
QUIT (DIN 2)	X3.12	Abort positioning cycle	No abort condition
FRESET (DIN 3)	X3.13	RESET Function active	RESET Function not active
HOME FLAG (DIN 4)	X3.14	Home flag = closing (or rising) edge	Home flag = open (or falling) edge
DIN 5	X3.15	Digital Input 6 = logical 1	Digital Input 6 = logical 0
Ma1 1 (DIN 6)	X3.16	Machine Input 1 = logical 1	Machine Input 1 = logical 0
Ma1 2 (DIN 7)	X3.17	Machine Input 2 = logical 1	Machine Input 2 = logical 0
DIN 8	X12.1	Digital Input 8 = logical 1	Digital Input 8 = logical 0
DIN 9	X12.14	Digital Input 9 = logical 1	Digital Input 9 = logical 0
DIN 10	X12.2	Digital Input 10 = logical 1	Digital Input 10 = logical 0
DIN 11	X12.15	Digital Input 11 = logical 1	Digital Input 11 = logical 0
DIN 12	X12.3	Digital Input 12 = logical 1	Digital Input 12 = logical 0
DIN 13	X12.16	Digital Input 13 = logical 1	Digital Input 13 = logical 0
DIN 14	X12.4	Digital Input 14 = logical 1	Digital Input 14 = logical 0
DIN 15	X12.17	Digital Input 15 = logical 1	Digital Input 15 = logical 0
Trigger (DIN 16)	X12.5	Trigger = closing (or rising) edge	Trigger = open (or falling) edge
DIN 17	X12.18	Digital Input 17 = logical 1	Digital Input 17 = logical 0

7.7.1 Input Signals X12

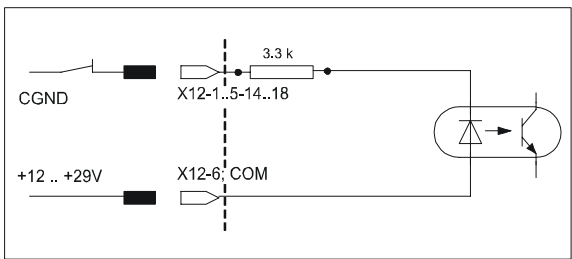
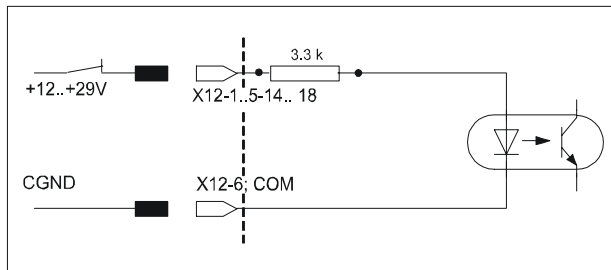
I/O - Expansion	Signal	Connector X12	Hardware
Function	Signal	PIN	
Input	DIN 8	1	<p>- Low Active:</p>  <p>- High Active:</p>  <p>min. input impedance $R_{IN} = 3.3 \text{ k}\Omega$; opto coupled; $U_{IN} = 12..29 \text{ VDC}$; Delay time $T_d = 7.7 \mu\text{s}$ (on); $T_d = 45 \mu\text{s}$ (off) max. current at 24V: $I = 7.5 \text{ mA}$</p>
Input	DIN 9	14	
Input	DIN 10	2	
Input	DIN 11	15	
Input	DIN 12	3	
Input	DIN 13	16	
Input	DIN 14	4	
Input	DIN 15	17	
Common	COM	6	
Trigger	DIN 16	5	
Input	DIN 17	18	

7.7.2 Output Signals X12

Signal name	Connector Pin	Switch Position / Function	
		active / closed	not active / open
DOUT 3	X12.12	Digital Output 3 = logical 1	Digital Output 3 = logical 0
DOUT 4	X12.24	Digital Output 4 = logical 1	Digital Output 4 = logical 0
DOUT 5	X12.11	Digital Output 5 = logical 1	Digital Output 5 = logical 0
DOUT 6	X12.23	Digital Output 6 = logical 1	Digital Output 6 = logical 0
DOUT 7	X12.10	Digital Output 7 = logical 1	Digital Output 7 = logical 0
USR +	X12.25	-	-
USR GND	X12.13	-	-

Digital Outputs Connector X12			Hardware
Function	Signal	PIN	
Output	DOUT 3	12	
Output	DOUT 4	24	
Output	DOUT 5	11	
Output	DOUT 6	23	
Output	DOUT 7	10	
Customer Interface Voltage	USR +	25	
Ground Return	USR GND	13	

APPENDIX

APPENDIX A

EMC Installation Instructions

To ensure electromagnetic compatibility (EMC) at hostile environment inside the cabinet following instructions are to be observed for construction. The implementation of following provisions enables the reduction of interference down to required levels.

For the Drives technology following key points are to be considered:

- **Grounding**
- **Screening**
- **Filtering**

Furthermore the relevant chapters of the Installation manual for the controllers have to be observed. For installation of the drives system the starting point is the installation into a cabinet.

For construction of a cabinet the following installation instructions have to be considered:

- A) All metal conducting parts of a cabinet should be arealy conducted to the back plane. Eventually the connections should be placed with an earthing strap at a central grounding point .1)**
- B) There should be a spatial separation between power wiring (motor and power cable) and control wiring. (Avoid interaction space)**
- C) The screen connection of the signal and power cables should be arealy conducted to the screen rails or clamps. The screen rails or clamps should be well conducted to the cabinet.**
- D) The cable to the regeneration resistor has to be screened. The screen connection should be on both sides.**
- E) The location of the mains filter has to be situated close to the drive.**
- F) Cables running inside the cabinet should be placed as close as possible to conducting metal, cabinet walls and plates. It is advised to terminate unused wires to chassis ground. 1)**
- G) In case of bad potential balance between the screen connections a compensating lead with at least 10mm² has to be provided additionally to reduce the screen current.**

1) Grounding in general describes all metal parts which can be connected to a protective conductor, e.g. housing of cabinet, motor housing, fundament grounder.

EMC Wiring Principle (Example)

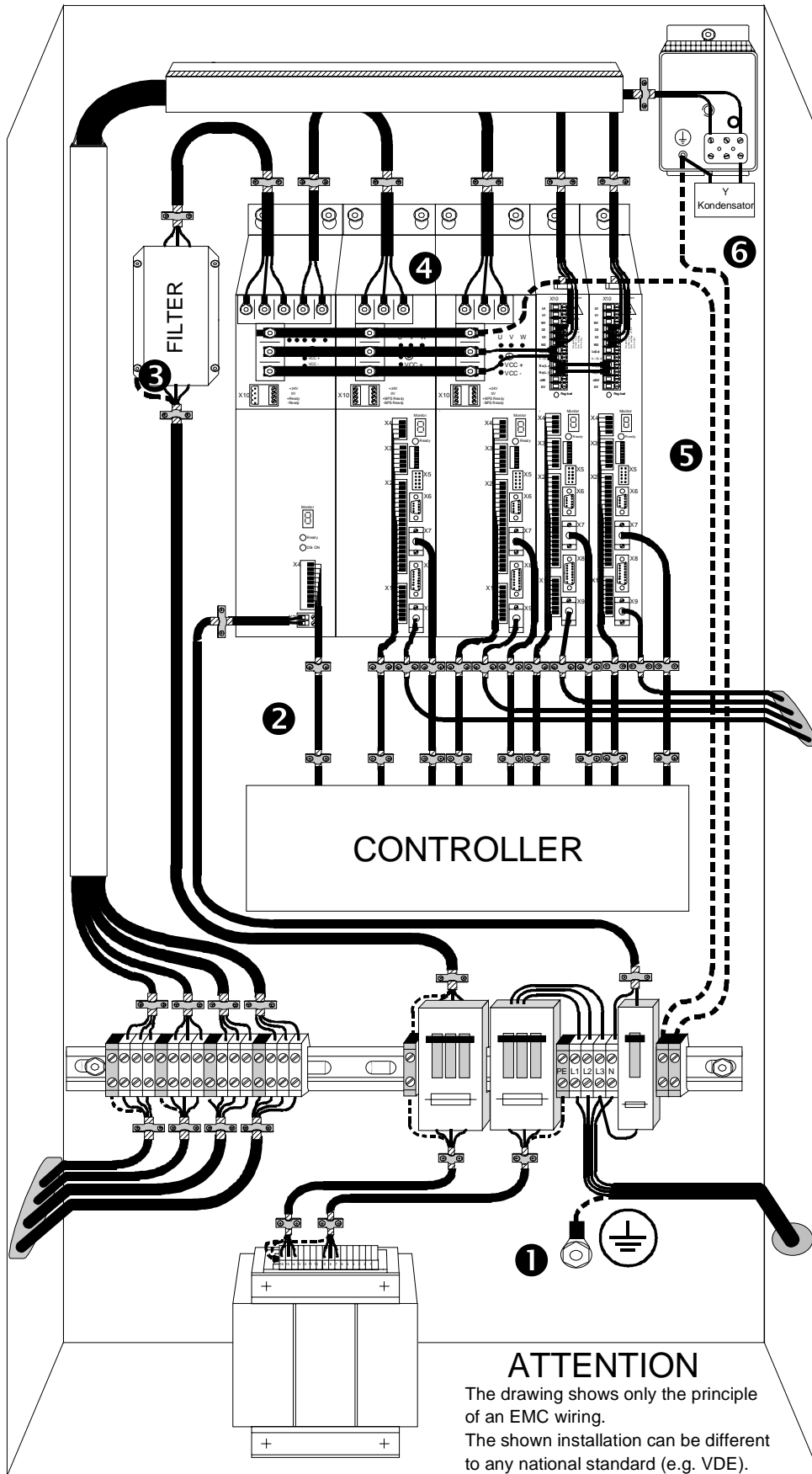

1 CABINET

The drawing shows a cabinet with an electroplated zinc coated back plane, which is arealy conducted to earth. This design will bring the following advantages:

- All parts mounted on the back plane are arealy conducted to earth.
- All screen connections will have a very low impedance to the earth.

General component placement within the cabinet:

There should be a spatial separation between power wiring (motor and power cable) and control wiring.

2 SCREEN CONNECTIONS

All connections between the components should be wired with screened cables.

The cable screens should be connected to screen clamps on both sides.

With this wiring a very good screening effect can be achieved, because the clamps are arealy conducted to the cabinet back plane.

3 EMC - FILTER

The EMI or main filter should be mounted next to the power supply.

For the connection to and from the main filter screened cables should be used. The cable screens should be connected to screen clamps on both sides.

4 WIRING OF SCREENED CABLES

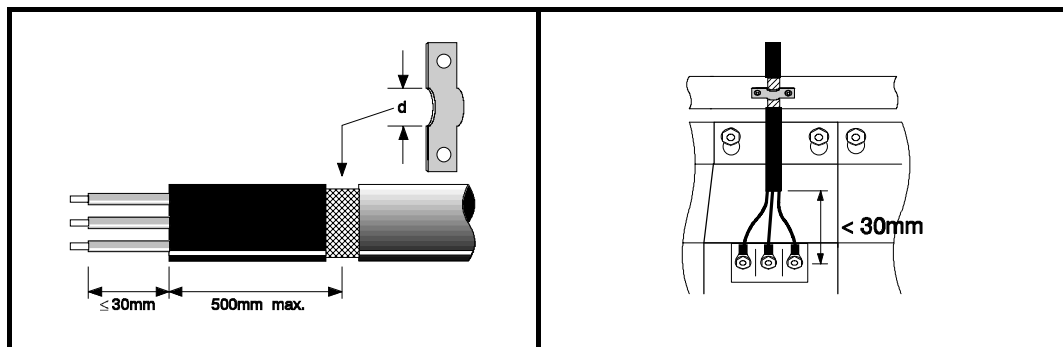

5 EARTHING

For safety reasons (VDE0160), all components must be connected to earth with a separate cablelead.

The diameter of the cablelead must be at minimum 10mm².

An earth connection from the power side must be linked to the housing of the main filter. Between the main filter and the power supply, no earth connection has to be wired.

6 Y-CAPACITOR

The connection of the regeneration resistor can cause radio emission to be very high. For minimisation of these emissions it is recommended that a Y-capacitor is connected as shown.

The capacitor should only be connected between the resistor housing and terminal pin R1.

Recommendation: 0,1µF / 250VAC Type: PME265 Supplier: RIFA

APPENDIX B

DIMENSIONS

A) Drive, Standard-Series without I/O Expansion

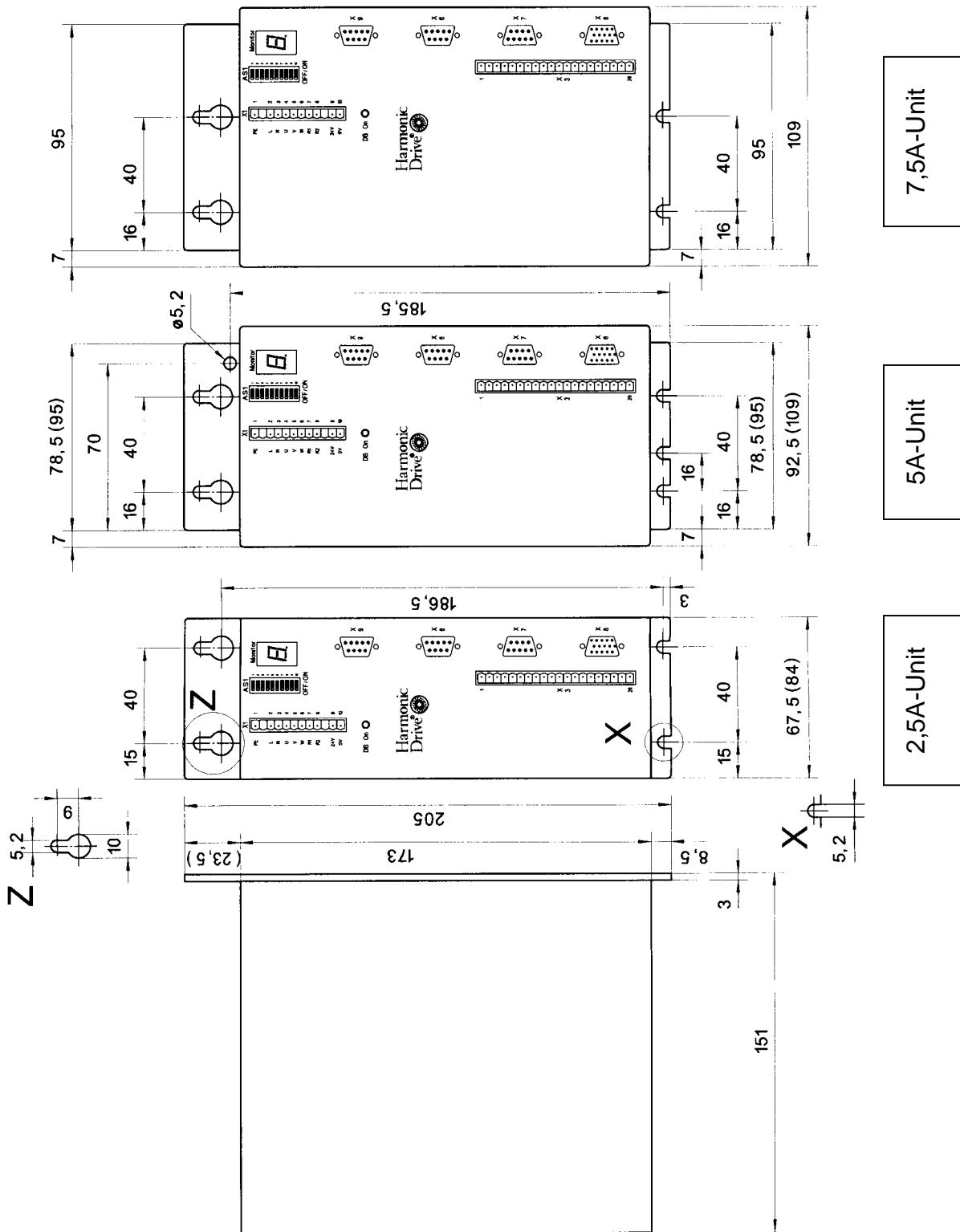

(Values in () refer to the controllers with additional binary inputs.

B) Main - Filter

Single - phase filter

Dimensions for the following main filters:

FN – 2070 – 06 – 06

FN – 2070 – 10 – 06

FN – 2070 - 12 – 06

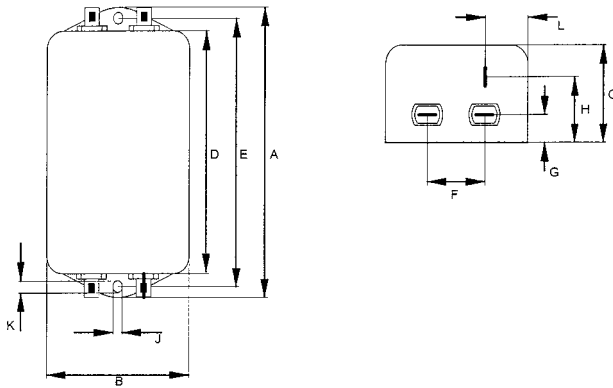

not scaled (dimensions in mm)

Dimensions in mm		
	FN – 2070 - 6 - 06	FN – 2070 - 10 – 06 FN – 2070 - 12 – 06
A	113.5	156
B	57.5	
C	46.6	
D	94	130.5
E	103	143
F	25	
G	12.4	
H	32.4	
J	4.4	5.3
K	6	
L	15.5	

C) Regeneration Resistor

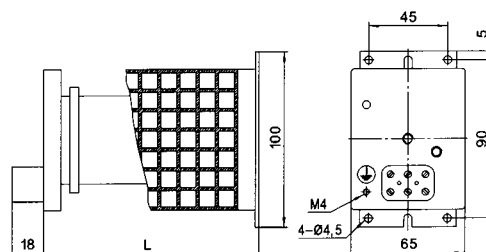

not scaled (dimensions in mm)

L = 123 for HA-R56

L = 228 for HA-R39

APPENDIX C

TROUBLESHOOTING

Monitor	Status	Cause
-	Amplifier disabled	no fault
8	Amplifier enabled	no fault
1.	Overvoltage amplifier DC bus voltage	Missing, damaged or wrong designed regeneration resistor.
2.	Integrated Power Module (IPM) Trip	The unit's power base has been overloaded
3.	Overcurrent 2x Peak Current Crest Value	Power stage fault or motor leads short circuit
4.	Undervoltage;	DC bus voltage has dropped below the powerbase undervolts level
5.	Feedback fault	Parting of the cable or resolver leads short circuit or missing plug-in connection
6.	Electronic Fusing (see Fault 7 also)	Amplifier or motor active current overload. Fault detection via software.
7	1) I ² t-Limit Controller/Motor If I ² t-limit is reached, amplifier will reduce output current to it's nominal value. After 2.4s ± 0.5s drive switches off (amplifier disable) with fault indication "6; electronic fusing" 2) Motor overtemperature 3) Amplifier overtemperature	1) Cycle time between motor acceleration and deceleration is too short. (Duty cycle too high) 2) Missing or faulty motor thermoswitch wiring. Amplifier undersized; active motor torque to high. 3) Amplifier ambient temperature too high.
0.	Watchdog When the display shows a "0." a watchdog timeout occurred in the processor.	Drive / comms watchdog. Interprocessor failure. Clear the error.
- .	Limit switch (clock wise) active When the status monitor displays a "- .", the CW-limit switch has been activated. <i>Probable Cause:</i> Check wiring of X3.10 or limit switch	
-.	Limit switch (counter clock wise) active When the status monitor displays a " -.", the CCW-limit switch has been activated. <i>Probable Cause:</i> Check wiring of X3.11 or limit switch	
-	Amplifier disabled When the status monitor display is blank, the amplifier is disabled and there is no fault. When the status monitor displays a "d", the amplifier has been disabled. <i>Probable Cause:</i> The amplifier can be disabled by an input, a DIP switch, or by the setup software.	
F.	Fatal Following Error When the status monitor displays a "F." the Following Fatal Error is activated after following error exceeds the user defined Following Fatal Error band.	
S	Stop - Mode When the status monitor displays a "S" the control has been placed in the STOP (previous HOLD) position mode. <i>Probable Cause:</i> The hold position mode can be activated by an input X3.12, the DIP-switch AS1.5, or by the setup software .	
J	Jog - Mode When the status monitor displays a "J." the control is in "Jog" system mode. The "Jog-Mode" can be stopped or started by the setup software.	

Problem diagnosis

If you have followed all the instructions in this manual in sequence, you should have few problems installing the SC-Drive. If you do have a problem, read this section first. In WorkBench v5, use the Error Log tool to view recent errors and then check the help file. If you cannot solve the problem or the problem persists, the SupportMe™ feature can be used.

SupportMe™ feature

The SupportMe™ feature (on the Help menu) can be used to e-mail information to technical support departments (or anyone else you choose). If required, you can choose to add your program files as attachments. WorkBench v5 will automatically start up your e-mail program and begin a new message, with comprehensive system information and selected attachments already in place. You can add any additional message of your own and then send the e-mail. The PC must have email facilities to use the SupportMe™ feature. If you prefer to contact technical support by telephone or fax, contact details are provided at the front of this manual. Please have the following information ready:

- The serial number of your SC-Drive.
- The catalog number indicating the type of SC-Drive you have.
- Use the Help, about menu item in WorkBench v5 to view details about your system.
- The catalog and specification numbers of the motor that you are using.
- Give a clear description of what you are trying to do, for example trying to establish communications with WorkBench v5 or trying to perform fine-tuning.
- Give a clear description of the symptoms that you can observe, for example the Status display, error messages displayed in WorkBench v5, or the current value of any of the MintMT error keywords `AXISERROR`, `AXISSTATUS`, `INITERROR`, `MISCERROR` and `DRIVEERROR`.
- The type of motion generated in the motor shaft.
- Give a list of any parameters that you have setup, for example the motor data you entered/selected in the Commissioning Wizard, the gain settings generated during the tuning process and any gain settings you have entered yourself.

Power-cycling the SC-Drive

The term „Power-cycle the SC-Drive is used in the Troubleshooting sections. On models with a customer supplied 24V supply, remove the 24V supply, wait for the SC-Drive to power down completely (all Status LED segments will turn off), then re-apply the 24V supply. On models with an internally generated 24V supply, remove the AC power supply, wait for the SC-Drive to power down completely (all Status LED segments will turn off), then re-apply AC power.

Power on

Problem	Check
The Status display is showing a flashing symbol with a static decimal point.	The SC-Drive has detected an error. Use the Error Log tool to view a list of recent errors, or click the Error button on the motion toolbar to view a description of the error. Alternatively, type any or all of these commands in the Command window: PRINT AXISERROR, PRINT DRIVEERROR, PRINT MISCERROR PRINT INITERROR. Click the Clear Errors button on the motion toolbar.

Tuning

Problem	Check
Cannot enable the SC-Drive because AXISERROR has bit 13 set	Check the drive enable input on connector X3 pins 7 and 9 is connected and powered correctly. Check that DIP switch 8 (enable) is set to the On position.
When the SC-Drive is enabled the motor is unstable	Check that the current loop has been tuned. Check that the current loop was tuned with the correct motor data. If the motor is still unstable try reducing the Speed Proportional gain (KVPROP) and Speed Integral gain (KVINT) on the Speed tab of the Fine-tuning window.
I get a Following Error (AXISERROR bit 5 is set) and the drive disables when tuning the gains	Set FOLERRORMODE to zero to ignore the following error while tuning the gains.
I get a Software limit error (AXISERROR bits 3 or 4 set) and the drive disables when tuning the gains	Set SOFTLIMITMODE to zero to ignore the software limit error while tuning the gains.
I get a Hardware limit error (AXISERROR bits 1 or 2 set) and the drive disables when tuning the gains	Set LIMITMODE to zero to ignore the hardware limit errors while tuning the gains. Alternatively, disable the hardware limit inputs.

Status LED shows a digit or 'E.'

If the Status display shows a flashing digit, 'E', or the forward or reverse hardware limit symbol, use the Error Log tool to view a list of recent errors. Alternatively, type PRINT DRIVEERROR, PRINT AXISERROR and PRINT MISCERROR as separate commands in the WorkBench v5 Command window. Each of these commands will return an error code, a description of which can be found in the help file.

Press F1 and locate the DRIVEERROR, AXISERROR and MISCERROR keywords. The *Error Handling* book contains topics listing the Status display indicators and basic error codes. Remember that many error codes are the sum of a bit pattern so may not be listed individually. For help on understanding bit pattern values, see the *Bit pattern values* topic in the *Keywords* book

APPENDIX D

Multi - Drop - Applications

This mode is available setting DIP-switch no. 10 at the front panel of the drive to ON. The wiring principle for multi-drop applications is shown below. Each connected drive will also get it's own hardware address. The setting can be done by DIP-switches AS1-4 on the front panel or by using the setup software Work Bench v5.

The picture below shows termination resistors on the last connected drive. The resistor can be activated by using DIP-switch AS1.6 and set it to ON-position.

Multi-drop wiring principle for RS485:

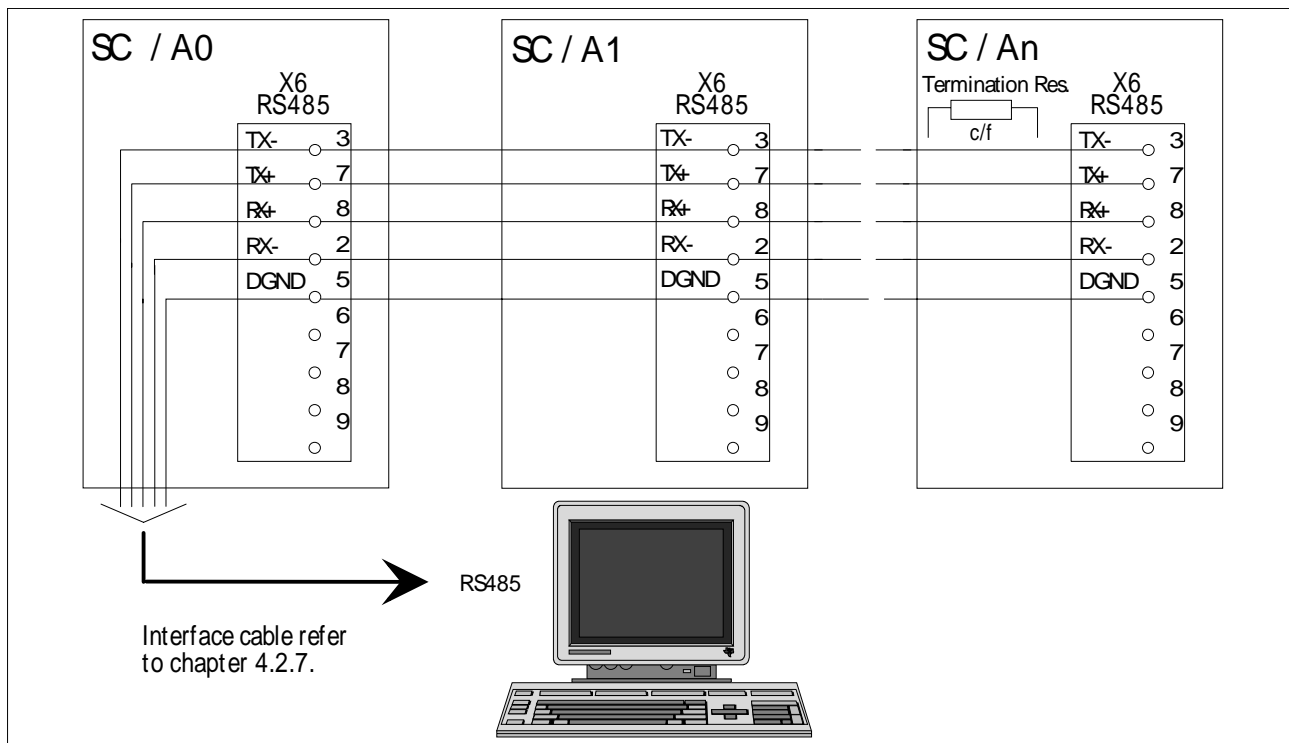

APPENDIX E

Software Installation

General: The WorkBench set-up software is Windows-based and guides you through all steps necessary, to set-up your Servo Drive via a serial port of your PC. Online-Help to each topic makes a manual obsolete.

A) Minimum system requirements

Hardware requirements (minimum):

Processor:	Intel Pentium / 133 MHz
RAM:	32MByte
Hard Disk Space:	40Mbyte
Screen:	800 x 600 (min.)
Recommended:	Intel Pentium, 64 MB RAM, 200 MHz, 60MB hard disk space free

Software requirements:

Operating System:	Windows 2000
Recommended:	Windows 98, Windows ME, Windows 2000 (SP4+), Windows XP (SP1+)

B) Installation

To install the WorkBench software on your computer's hard disk, please follow the sequence described below:

- 1.) Start Windows. Make sure, that no other programs are running, while Installation of WorkBench is done.
- 2.) Place Installation CD ROM in your computer's CD ROM drive.
- 3.) Look for E: (if E is your CD ROM drive) and double click on Setup_XXXX.exe.
- 4.) According to demands from the installation process, insert Installation Disk with required number.

After installation process is finished, a Program Manager Group for WorkBench with WorkBench ProgMan Icon is created. Double clicking this icon will start the WorkBench set-up program.

Appendix F

Definition of Parameters for Controller-Setup

1 Motor-Parameters referred to the Motor Shaft

K_E	=	Voltage constant in V/Krpm effective value (rms)
Pole Pairs	=	Number of poles divided by 2
I_{MAX}	=	Maximum peak current
I_{RATED}	=	Continuous current
R_A (L-L)	=	Armature resistance measured between U and V or double of phase resistance given in the catalogue
L_A (L-L)	=	Armature inductance measured between U and V or field inductance given in the catalogue
K_T	=	Torque constant
J_{ROTOR}	=	Moment of Inertia of the Motor (without gear)

2 System-Parameters

N_{MAX}	=	Maximum motor speed at 10V demand input
Enc. Res.	=	Number of encoder counts per one motor revolution
Power Supply	=	Amplifier power supply voltage depending on the actuator

3 System Configuration

HD-No.	=	Part number given on the type label at the front panel showing the parameter settings ex stock. First 6 numbers specify the basic unit. Last 2 numbers define the parameter settings.
Mod.-No.	=	Part number given on the additional label at the front panel showing customers specific parameter settings, if specified. This Mod.-No. „overwrites“ the HD-No.

The individual motor parameters are given within the motor database of the setup software **Work Bench v5** and will be updated on regular basis.

APPENDIX G

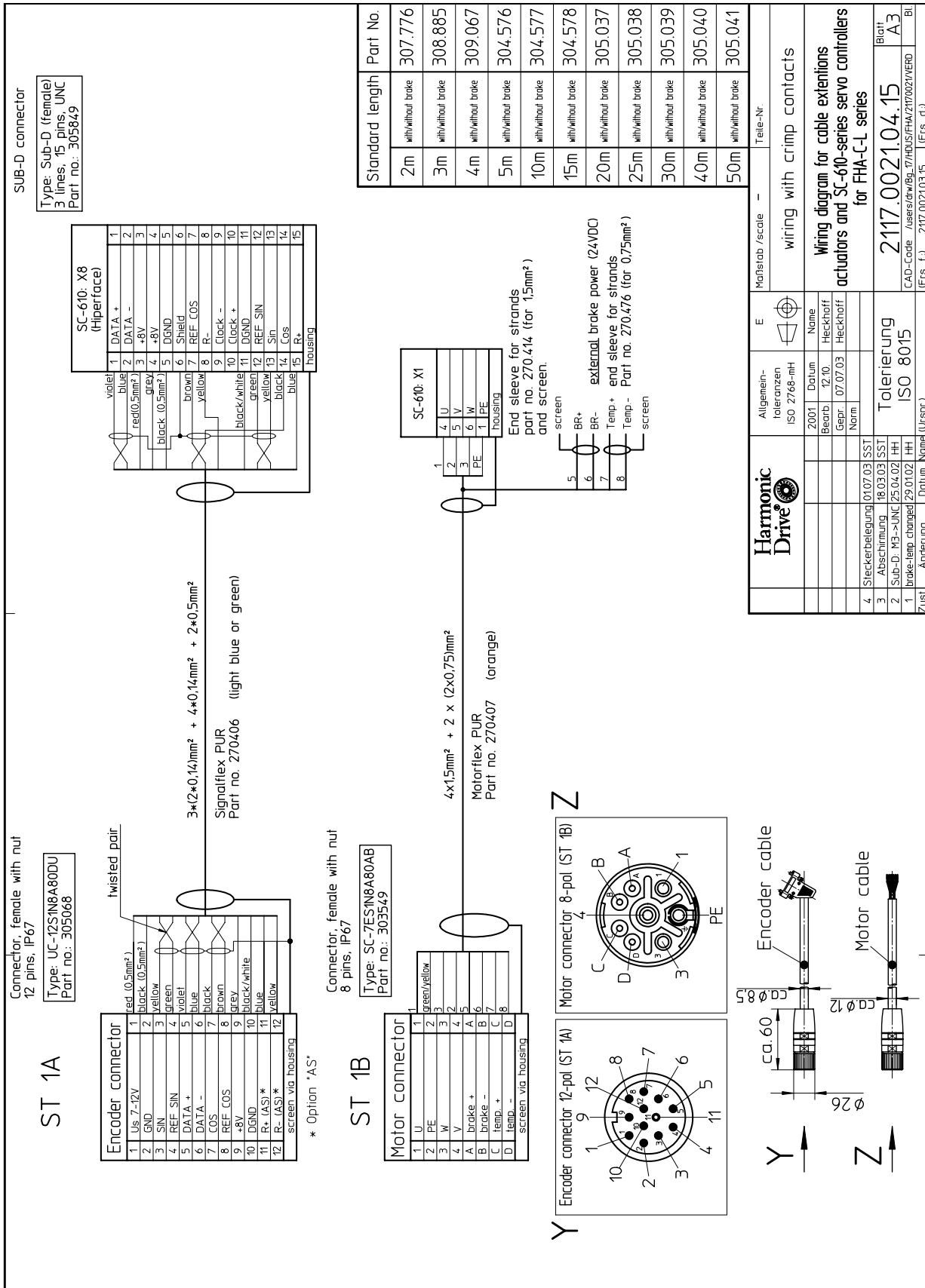

SUB-D connector

Type: Sub-D (female)
3 lines, 15 pins, UNC
Part no.: 305849

SC-610: X8 (Hyperface)	
1	DATA +
2	DATA -
3	+8V
4	+8V
5	DGND
6	Shield
7	REF COS
8	R-
9	Clack -
10	Clack +
11	DGND
12	REF SIN
13	SIN
14	COS
15	R+
	Housing

SC-610: X1	
1	U
2	V
3	W
4	PE
	Housing

End sleeve for strands
part no. 270414 (for 1,5mm²)
and screen.

external brake power (24VDC)
end sleeve for strands
part no. 270476 (for 0,75mm²)

Standard length	Part No.
2m with/without brake	307.776
3m with/without brake	308.885
4m with/without brake	309.067
5m with/without brake	304.576
10m with/without brake	304.577
15m with/without brake	304.578
20m with/without brake	305.037
25m with/without brake	305.038
30m with/without brake	305.039
40m with/without brake	305.040
50m with/without brake	305.041

Harmonic Drive	Allgemein-toleranzen ISO 2768-mH	E	Maßstab /scale -
	2001 Datum		wiring with crimp contacts
	Bearb. 12.10. Heckhoff	Name	
	Gespr. 07.07.03 Heckhoff		
	Norm		
4. Steckerbelegung 01.07.03 SST			
3. Abschirmung 18.03.03 SST			
2. Sub-D. M3->UNC 25.04.02 HH			
1. brake-temp changed 29.01.02 HH			
Zust! Änderung Datum Name (Urspr)			
	Tolerierung		
	ISO 8015		
	2117.0021.04.15		
	/users/dw/Bq.7/HDSJ/FHA/2170021/VERD		
	(Efs. f.) 2117.0021.03.15		
			Blatt A3

Wiring diagram for cable extensions
actuators and SC-610-series servo controllers
for FHA-C-L series

APPENDIX H

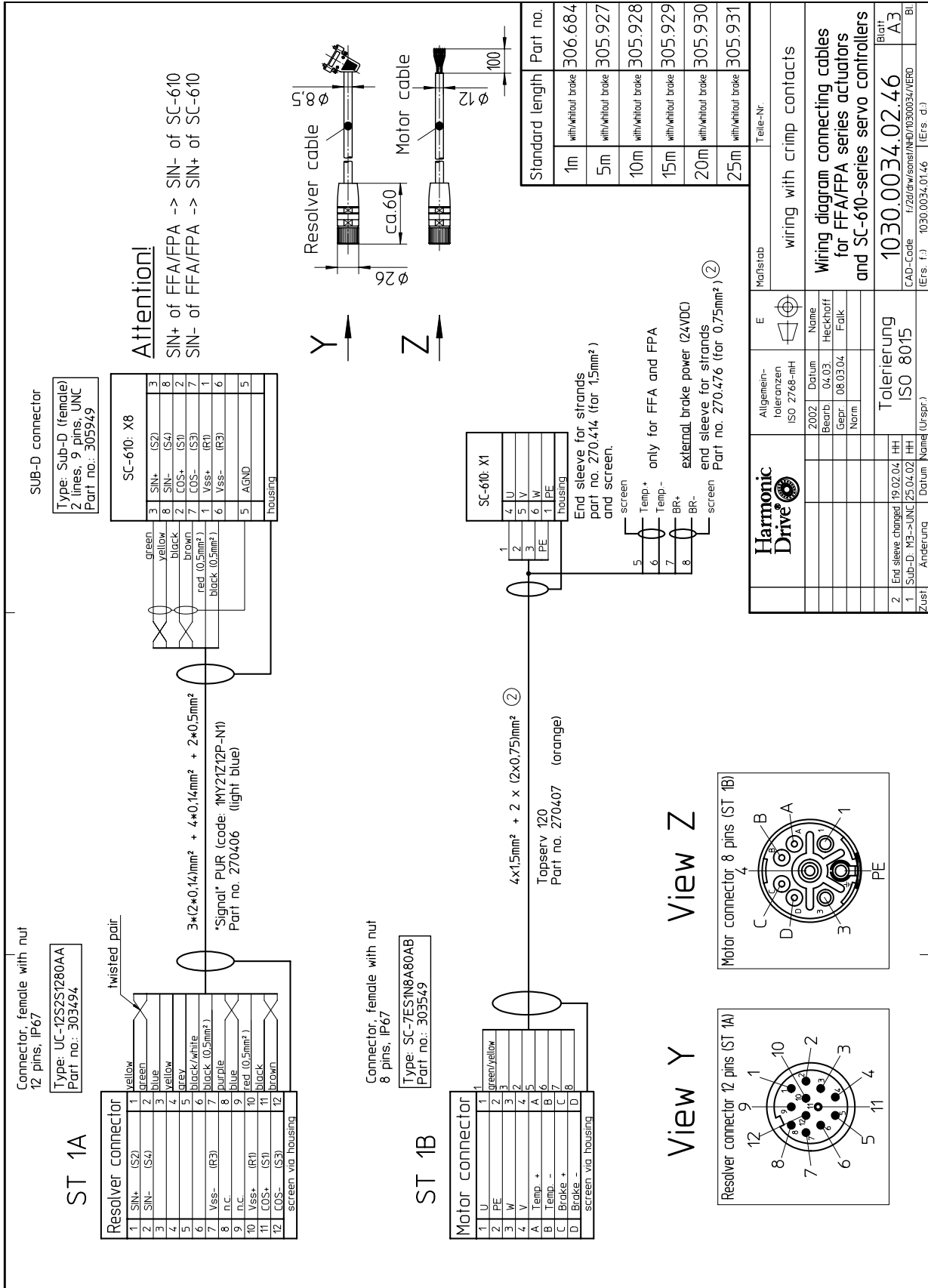

APPENDIX I

