

SIMATIC

WinAC Controlling with CPU 412-2 PCI/CPU 416-2 PCI Setting Up, CPU Data Version 3.3

Manual

This manual is part of the product packages with the order number:

6ES7 673-6CC21-0YA0
6ES7 673-6CC01-0YA0

Edition 01/2003

A5E00065507-05

| | |
|---|----|
| Preface, Contents | 1 |
| Product Overview | 2 |
| Installing a CPU 41x-2 PCI and PS Extension Board | 3 |
| Installing WinAC Slot 41x | 4 |
| Commissioning | 5 |
| CPU 412-2 PCI and CPU 416-2 PCI Control Panel | 6 |
| CPU 41x-2 PCI as DP Master/DP Slave and Direct Data Exchange | 7 |
| Time Synchronization (WinACTimeSync) | 8 |
| CPU 412-2 PCI/CPU 416-2 PCI – Tech. Specifications, Compatibility | 9 |
| PS Extension Board | 10 |
| Memory Cards | |
| Appendix | |
| General Technical Specifications | A |
| Networking | B |
| FAQs: Frequently Asked Questions about WinAC Slot 41x | C |
| Panel Control | D |
| Spare Parts and Accessories – Order Numbers | E |
| Guidelines for Handling Electrostatic Sensitive Devices (ESD) | F |
| List of Abbreviations | G |
| Glossary, Index | |

Safety Guidelines

This manual contains notices intended to ensure personal safety, as well as to protect the products and connected equipment against damage. These notices are highlighted by the symbols shown below and graded according to severity by the following texts:



Danger

indicates that death, severe personal injury or substantial property damage will result if proper precautions are not taken.



Warning

indicates that death, severe personal injury or substantial property damage can result if proper precautions are not taken.



Caution

indicates that minor personal injury can result if proper precautions are not taken.

Caution

indicates that property damage can result if proper precautions are not taken.

Notice

draws your attention to particularly important information on the product, handling the product, or to a particular part of the documentation.

Qualified Personnel

Only **qualified personnel** should be allowed to install and work on this equipment. Qualified persons are defined as persons who are authorized to commission, to ground and to tag circuits, equipment, and systems in accordance with established safety practices and standards.

Correct Usage

Note the following:



Warning

This device and its components may only be used for the applications described in the catalog or the technical description, and only in connection with devices or components from other manufacturers which have been approved or recommended by Siemens.

This product can only function correctly and safely if it is transported, stored, set up, and installed correctly, and operated and maintained as recommended.

Trademarks

SIMATIC®, SIMATIC HMI® and SIMATIC NET® are registered trademarks of SIEMENS AG.

Third parties using for their own purposes any other names in this document which refer to trademarks might infringe upon the rights of the trademark owners.

Copyright © Siemens AG 2001-2002 All rights reserved

The reproduction, transmission or use of this document or its contents is not permitted without express written authority. Offenders will be liable for damages. All rights, including rights created by patent grant or registration of a utility model or design, are reserved.

Siemens AG
Bereich Automation and Drives
Geschäftsgebiet Industrial Automation Systems
Postfach 4848, D- 90327 Nuernberg

Siemens Aktiengesellschaft

Disclaim of Liability

We have checked the contents of this manual for agreement with the hardware and software described. Since deviations cannot be precluded entirely, we cannot guarantee full agreement. However, the data in this manual are reviewed regularly and any necessary corrections included in subsequent editions. Suggestions for improvement are welcomed.

© Siemens AG 2001-2002
Technical data subject to change.

A5E00065507



Preface

Purpose of the manual

The information contained in this manual will help you to:

- configure a programmable logic controller with a CPU 412-2 PCI/416-2 PCI on a PC
- look up operator entries, descriptions of functions and technical specifications.

Essential basic skills

To understand the manual, general knowledge of automation engineering is required.

In addition, knowledge of the following is required:

- Extensive knowledge of the S7-400
- Extensive knowledge of STEP 7

Applicability of the manual

The present manual applies to the following modules:

| CPU | Order No. | As of Version | |
|--------------------|----------------------|---------------|----------|
| | | Firmware | Hardware |
| CPU 412-2 PCI | 6ES7 612-2QH00-0AB4* | 3.1 | 1 |
| CPU 416-2 PCI | 6ES7 616-2QL00-0AB4* | 3.1 | 1 |
| PS extension board | 6ES7 678-1RA00-0XB0 | - | 1 |

* As spare part

This manual describes all modules that are valid as of the time the manual was released. For new modules or newer versions of modules, we reserve the right to enclose a product information leaflet containing the current information on the module(s) concerned.

This manual describes the differences of the CPU 412-2 PCI and CPU 416-2 PCI from the CPUs in the S7-400 series. You will find additional information in the S7-400 manuals.

Changes from the previous version

Compared to the previous version, WinAC Slot 41x, version 3.2, the following changes have been implemented (refer also to section 8.4):

- WinAC Slot can also be operated under Windows XP Professional
- Windows NT 4.0 is no longer supported.
- Using SFC 126 "SYNC_PI" and SFC 127 "SYNC_PO" you can update process image partitions synchronous to the DP clock.
- Using SFC 103 "DP_TOPOL" you can determine the bus topology of a DP master system by triggering the diagnostics repeater.

Certification

The CPUs 41x-2 PCI and the PS extension board have the following certification:

- Underwriters Laboratories, Inc.: UL 508 registered (Industrial Control Equipment)
- Canadian Standards Association: CSA C22.2 number 142, (Process Control Equipment)
- Factory Mutual Research: Approval Standard Class Number 3611.

CE Labeling

The CPUs 41x-2 PCI and the PS extension board fulfil the requirements and protection guidelines of the following EU directives:

- EC Directive 73/23/EEC "Low-voltage directive"
- EC Directive 89/336/EEG "EMC directive"

CTick Mark

The CPUs 41x-2 PCI and the PS extension board are compliant with requirements of the AS/NZS 2064 (Australian) standard.

Standards

The CPUs 41x-2 PCI and the PS extension board fulfil the requirements and criteria of IEC 61131-2.

Refer to appendix xx to find out the norms the CPUs are compliant with.

Operation list

The operation list contains a concise summary of all important information relating to the operation set of all S7-400 CPUs. The data of the CPU 412-2 PCI are identical to those of CPU 412-2 DP, while the data of the CPU 416-2 PCI are the same as those for CPU 416-2 DP.

How the manual fits in

This manual describes the differences of the CPU 412-2 PCI and CPU 416-2 PCI from the CPUs in the S7-400 series. In addition, you will require the following documentation:

Table 1-1 How the Manual Fits In

| Manual/Manual Package | Contents |
|--|--|
| Basic Grounding in STEP7 <ul style="list-style-type: none"> • <i>Getting Started and Exercises with STEP 7</i> • <i>Programming with STEP 7</i> • <i>Configuring Hardware and Connections with STEP 7</i> • <i>From S5 To S7, Conversion Guide</i> | The basic grounding for technical staff describing the procedures for implementing control tasks with STEP 7. |
| STEP7 reference <ul style="list-style-type: none"> • <i>LAD/FBD/STL Manual for S7-300/400</i> • <i>Standard and System Functions for S7-300/400</i> | Reference works describing the programming languages LAD, CSF and STL as well as standard and system functions additional to the STEP 7 basic grounding. |
| S7-400 manuals <ul style="list-style-type: none"> • <i>S7-400, M7-400 Programmable Controllers Manual; Hardware and Installation</i> • <i>S7-400, M7-400 Programmable Controllers Reference Manual; Module Specifications</i> | The basic and reference knowledge referring to S7-400 CPUs, which is required for the CPU 412-2 PCI and CPU 416-2 PCI manuals. |
| <i>Communications with SIMATIC</i> | <ul style="list-style-type: none"> • Overview of communications on the SIMATIC S7 |
| <i>SIMATIC NET PROFIBUS Networks</i> | <ul style="list-style-type: none"> • Overview of PROFIBUS networks, topologies and passive components for PROFIBUS |
| <i>Manuals for SIMATIC PCs</i> | <ul style="list-style-type: none"> • Description of the PCs for SIMATIC |
| Manual PG 7xx | <ul style="list-style-type: none"> • Description of programming device hardware • Connecting a programming device to different devices • Commissioning a programming device |

Guide

You can quickly access specific information in the manual by using the following aids:

- At the beginning of the manual you will find a complete table of contents and a list of the diagrams and tables that appear in the manual.
- You will find a glossary in the appendix at the end of the manual. The glossary contains definitions of the main technical terms used in the manual.
- At the end of the manual you will find a comprehensive index which gives you rapid access to the information you need.

Recycling and Disposal

The CPUs 41x-2 PCI and the PS extension board are recycleable due to their non-toxic materials. Please contact a company certified in the disposal of electronic scrap for environmentally safe recycling and disposal of your old device.

Further Support

If you have any technical questions, please get in touch with your Siemens representative or agent responsible.

<http://www.siemens.com/automation/partner>

Training Centers

Siemens offers a number of training courses to familiarize you with the SIMATIC S7 automation system. Please contact your regional training center or our central training center in D 90327 Nuremberg, Germany for details:

Telephone: +49 (911) 895-3200.

Internet: <http://www.sitrain.com>

A&D Technical Support

Worldwide, available 24 hours a day:



| | | |
|--|---|--|
| <p>Worldwide (Nuernberg) Technical Support</p> <p>24 hours a day, 365 days a year Phone: +49 (0) 180 5050-222 Fax: +49 (0) 180 5050-223 E-Mail: adsupport@siemens.com GMT: +1:00</p> | | |
| <p>Europe / Africa (Nuernberg) Authorization</p> <p>Local time: Mon.-Fri. 7:00 to 17:00 Phone: +49 (0) 180 5050-222 Fax: +49 (0) 180 5050-223 E-Mail: adautorisierung@siemens.com GMT: +1:00</p> | <p>United States (Johnson City) Technical Support and Authorization</p> <p>Local time: Mon.-Fri. 8:00 to 17:00 Phone: +1 (0) 423 262 2522 Fax: +1 (0) 423 262 2289 E-Mail: simatic.hotline@sea.siemens.com GMT: -5:00</p> | <p>Asia / Australia (Beijing) Technical Support and Authorization</p> <p>Local time: Mon.-Fri. 8:30 to 17:30 Phone: +86 10 64 75 75 75 Fax: +86 10 64 74 74 74 E-Mail: adsupport.asia@siemens.com GMT: +8:00</p> |
| <p>The languages of the SIMATIC Hotlines and the authorization hotline are generally German and English.</p> | | |

Service & Support on the Internet

In addition to our documentation, we offer our Know-how online on the internet at:

<http://www.siemens.com/automation/service&support>

where you will find the following:

- The newsletter, which constantly provides you with up-to-date information on your products.
- The right documents via our Search function in Service & Support.
- A forum, where users and experts from all over the world exchange their experiences.
- Your local representative for Automation & Drives via our representatives database.
- Information on field service, repairs, spare parts and more under “Services”.

Contents

| | | |
|----------|--|------------|
| 1 | Product Overview | 1-1 |
| 1.1 | Components of a PLC Having a CPU 41x-2 PCI | 1-1 |
| 1.2 | Interfaces | 1-4 |
| 1.3 | Compatibility / System Requirements | 1-6 |
| 2 | Installing a CPU 41x-2 PCI and PS Extension Board | 2-1 |
| 2.1 | Fitting a CPU 41x-2 PCI and PS Extension Board | 2-1 |
| 2.1.1 | Turn Off the PC and Open it | 2-2 |
| 2.1.2 | Set Battery Monitoring | 2-3 |
| 2.1.3 | Screw the PS Extension Board to the CPU 41x-2 PCI | 2-4 |
| 2.1.4 | Insert the Memory Card | 2-5 |
| 2.1.5 | Plug the CPU 41x-2 PCI into the PC | 2-5 |
| 2.2 | Connecting a CPU 41x-2 PCI and PS Extension Board to the Voltage Supply | 2-6 |
| 2.2.1 | Important Information | 2-7 |
| 2.2.2 | Procedure for Connecting the PS Extension Board | 2-10 |
| 2.2.3 | Connecting the PS Extension Board to 12 V DC from the PC Power Supply | 2-11 |
| 2.2.4 | Connecting the PS Extension Board to an External 24 V DC Supply (Optional) | 2-12 |
| 2.2.5 | Connecting a Fan to the PS Extension Board | 2-13 |
| 2.3 | Installing and Connecting the Backup Battery | 2-14 |
| 2.4 | Checks before Initial Turn-On of the PC with CPU 41x-2 PCI | 2-17 |
| 3 | Installing WinAC Slot 41x | 3-1 |
| 3.1 | Installing the WinAC Slot 41x Software | 3-1 |
| 3.2 | Component Configurator: Configure PC Components within the PC | 3-4 |
| 3.3 | Uninstalling the WinAC Slot 41x Software | 3-6 |
| 4 | Commissioning | 4-1 |
| 4.1 | Points to Note when Integrating the Software | 4-1 |
| 4.2 | Recommended Procedure for Commissioning | 4-2 |
| 4.3 | Resetting the CPU with the Mode Switch | 4-4 |
| 4.4 | Connecting a Backup Battery (Option) | 4-5 |
| 4.5 | Reset Button: Resetting the Module | 4-8 |
| 5 | CPU 412-2 PCI and CPU 416-2 PCI Control Panel | 5-1 |
| 5.1 | Overview | 5-2 |

| | | |
|----------|---|------------|
| 5.2 | Controls and Display Elements of CPU 41x-2 PCI | 5-3 |
| 5.3 | Status and Error Indications | 5-4 |
| 5.4 | Operating Mode Controls | 5-8 |
| 5.4.1 | Selecting the Startup Type | 5-9 |
| 5.4.2 | Protection Levels | 5-10 |
| 5.5 | Loading and Saving the STEP 7 User Program | 5-11 |
| 5.5.1 | A Few Explanations before Proceeding | 5-11 |
| 5.5.2 | Saving and Loading the STEP 7 User Program | 5-12 |
| 5.6 | CPU 41x-2 PCI Controls on the Menu Bar | 5-16 |
| 5.6.1 | "File" Menu | 5-17 |
| 5.6.2 | "CPU" Menu | 5-18 |
| 5.6.3 | "Customize" Submenu | 5-19 |
| 5.6.4 | "Safety" Submenu | 5-21 |
| 5.6.5 | "Connect CPU" Submenu | 5-23 |
| 5.6.6 | "Help" Menu | 5-23 |
| 6 | CPU 41x-2 PCI as DP Master/DP Slave and Direct Data Exchange | 6-1 |
| 6.1 | DP Address Area of CPUs 41x-2 PCI | 6-2 |
| 6.2 | CPU 41x-2 PCI as DP Master | 6-3 |
| 6.3 | Diagnostics of CPU 41x-2 PCI as DP master | 6-6 |
| 6.4 | CPU 41x-2 PCI as DP Slave | 6-11 |
| 6.5 | Diagnostics of CPU 41x-2 PCI as a DP Slave | 6-16 |
| 6.5.1 | Diagnostics by Means of LED Displays | 6-17 |
| 6.5.2 | Diagnostics with STEP 5 or STEP 7 | 6-18 |
| 6.5.3 | Reading out the Diagnostics | 6-19 |
| 6.5.4 | Structure of Slave Diagnostics | 6-23 |
| 6.5.5 | Station Status 1 to 3 | 6-24 |
| 6.5.6 | Master PROFIBUS Address | 6-26 |
| 6.5.7 | Manufacturer's ID | 6-26 |
| 6.5.8 | Identifier-Related Diagnostics | 6-27 |
| 6.5.9 | Device-Related Diagnostics | 6-28 |
| 6.5.10 | Interrupts | 6-30 |
| 6.6 | Direct Data Exchange | 6-31 |
| 6.7 | Diagnostics During Direct Data Exchange | 6-32 |
| 7 | Time Synchronization (WinACTimeSync) | 7-1 |
| 7.1 | Overview | 7-2 |
| 7.2 | Assigning a CP to Time Synchronization | 7-4 |
| 7.2.1 | Setting the Access Point | 7-5 |
| 7.2.2 | Installing an Interface | 7-6 |
| 7.3 | Using the Time Synchronization Service | 7-8 |
| 7.3.1 | Starting and Terminating Time Synchronization | 7-8 |
| 7.3.2 | Setting the Interval for Time Synchronization | 7-9 |
| 7.4 | User Example | 7-10 |
| 7.4.1 | Task: Communication Using Time Synchronization | 7-10 |
| 7.4.2 | Component Configurator: Configure PC Components Within the PC | 7-11 |

| | | |
|-----------|--|-------------|
| 7.4.3 | Commissioning wizard: assigning CP 5613 | 7-11 |
| 7.4.4 | Creating a Project | 7-14 |
| 7.4.5 | Configuring an Access Point | 7-23 |
| 7.4.6 | Starting Time Synchronization | 7-24 |
| 8 | CPU 412-2 PCI and CPU 416-2 PCI – Technical Specifications and Compatibility .. | 8-1 |
| 8.1 | Overview of the Parameters for the CPU 41x-2 PCI | 8-2 |
| 8.2 | Performance Features and Technical Specifications of the CPU 412-2 PCI | 8-3 |
| 8.3 | Performance Features and Technical Specifications of the CPU 416-2 PCI | 8-7 |
| 8.4 | Differences of CPU 41x-2 PCI from Previous Version (CPU 41x-2 PCI Version 3.2) | 8-11 |
| 9 | PS Extension Board | 9-1 |
| 10 | Memory Cards | 10-1 |
| 10.1 | Design and Function | 10-1 |
| 10.2 | Types of Memory Cards | 10-2 |
| A | General Technical Specifications | A-1 |
| A.1 | Standards, Certificates and Approvals | A-1 |
| A.2 | Electromagnetic Compatibility | A-3 |
| A.3 | Shipping and Storage Conditions | A-4 |
| A.4 | Mechanical and Climatic Environmental Conditions | A-6 |
| A.5 | Certification for USA, Canada and Australia | A-8 |
| B | Networking | B-1 |
| B.1 | Configuring an MPI or PROFIBUS Subnet | B-1 |
| B.1.1 | Network Operation | B-1 |
| B.1.2 | Fundamentals | B-3 |
| B.1.3 | Rules for Configuring a Subnet | B-5 |
| B.1.4 | Cable Lengths | B-12 |
| B.2 | Network Components | B-15 |
| B.2.1 | PROFIBUS Bus Cable | B-15 |
| B.2.2 | Bus Connector | B-17 |
| B.2.3 | Plugging the Bus Connector into Modules | B-18 |
| B.2.4 | RS 485 Repeater | B-20 |
| B.2.5 | RS 485 Repeater in Ungrounded and Grounded Mode | B-22 |
| B.2.6 | Technical Specifications of the RS 485 Repeater | B-24 |
| B.3 | Commissioning PROFIBUS-DP | B-25 |
| C | FAQs: Frequently Asked Questions about WinAC Slot 41x | C-1 |
| C.1 | When do I use the PS extension board? | C-2 |
| C.2 | Why does the battery supply not reside on the CPU 41x-2 PCI? | C-2 |
| C.3 | How can I make it without a PS extension board? | C-3 |

| | | |
|----------|---|-------------------|
| C.4 | How can I save user data without a PS extension board when powering down and up? | C-4 |
| C.5 | Why do I still have to connect the PS extension board to the power supply of the PC (Y-cable)? | C-4 |
| C.6 | When do I use a FLASH card and when a RAM card? | C-5 |
| C.7 | Is operation possible without a memory card? | C-5 |
| C.8 | Can WinAC Slot 41x also be operated as a DP slave? | C-6 |
| C.9 | Does the PROFIBUS-DP interface integrated on the CPU 41x-2 PCI support the DP services (SFC58/59)? | C-6 |
| C.10 | Does WinAC Slot 41x support network routing? | C-6 |
| C.11 | Do I have to use another S7 driver to use the integrated Industrial Ethernet interface of the SIMATIC PC? | C-7 |
| C.12 | What are the advantages of using PCI? | C-7 |
| C.13 | How can PC applications access the process data of WinAC Slot 41x? .. | C-7 |
| C.14 | What are the advantages of using WinAC Slot 41x together with a SIMATIC Box PC 620? | C-8 |
| D | Panel Control | D-1 |
| D.1 | Accessing the CPU 41x-2 PCI with the Panel Control | D-2 |
| D.2 | Selecting the Control Engine for the Panel Control | D-5 |
| D.3 | Sample Programs Using the Panel Control | D-6 |
| D.4 | Evaluating the LED Indications of the Panel Control | D-10 |
| D.5 | Properties and Methods of the Panel Control | D-11 |
| D.6 | Events of the Panel Control | D-22 |
| E | Spare Parts and Accessories – Order Numbers | E-1 |
| F | Guidelines for Handling Electrostatic Sensitive Devices (ESD) | F-1 |
| F.1 | What are ESDs? | F-2 |
| F.2 | Electrostatic Charging of Persons | F-3 |
| F.3 | General Protective Measures Against Electrostatic Discharge Damage .. | F-4 |
| G | List of Abbreviations | G-1 |
| | Glossary | Glossary-1 |
| | Index | Index-1 |

Figures

| | | |
|------|---|------|
| 1-1 | Components of a PLC Having a CPU 41x-2 PCI | 1-1 |
| 1-2 | CPU 41x-2 PCI | 1-4 |
| 1-3 | PS Extension Board | 1-6 |
| 2-1 | Position of the Switch on CPU 41x-2 PCI | 2-3 |
| 2-2 | Screwing the CPU 41x-2 PCI to the PS Extension Board | 2-4 |
| 2-3 | Inserting a Memory Card in a CPU | 2-5 |
| 2-4 | Position of Cable Connectors on PS Extension Board | 2-10 |
| 2-5 | Box PC 620/Panel PC 760: Connectors for Connection to 12 V DC from PC Power Supply | 2-11 |
| 2-6 | Slot Plate with Hood | 2-14 |
| 2-7 | Plate for Battery Holder on PC Housing | 2-15 |
| 2-8 | Interfaces | 2-15 |
| 2-9 | 2-Pin 4.95 mm Coaxial Connector to Backup Battery | 2-16 |
| 3-1 | Installing the Components of WinAC Slot 41xx | 3-3 |
| 4-1 | CPU > FMR Menu Option | 4-7 |
| 5-1 | CPU 41x-2 PCI Control Panel | 5-2 |
| 5-2 | Controls and Display Elements of CPU 41x-2 PCI on the Control Panel . | 5-3 |
| 5-3 | Selecting the Startup Type | 5-9 |
| 5-4 | Loading the STEP 7 User Program into the Memory of CPU 41x-2 PCI . | 5-11 |
| 5-5 | Archiving | 5-13 |
| 5-6 | Restoring | 5-14 |
| 5-7 | Autoload | 5-15 |
| 5-8 | "File" Menu | 5-17 |
| 5-9 | "CPU" Menu | 5-18 |
| 5-10 | "General" Tab | 5-19 |
| 5-11 | "Language" Tab | 5-20 |
| 5-12 | "Autoload" Tab | 5-21 |
| 5-13 | "Access Rights" Dialog Box | 5-21 |
| 5-14 | "Access Verification" Dialog Box | 5-22 |
| 5-15 | "Change Password" Dialog Box | 5-22 |
| 5-16 | "Help" Menu | 5-23 |
| 6-1 | Diagnostics with CPU 41x-2 PCI | 6-8 |
| 6-2 | Diagnostics Addresses for DP Master and DP Slave | 6-9 |
| 6-3 | Transfer Memory in the CPU 41x-2 PCI as DP Slave | 6-12 |
| 6-4 | Diagnostics Addresses for DP Master and DP Slave | 6-21 |
| 6-5 | Structure of Slave Diagnostics | 6-23 |
| 6-6 | Structure of Identifier-Related Diagnostics of CPU 41x-2 PCI | 6-27 |
| 6-7 | Structure of Device-Related Diagnostics | 6-28 |
| 6-8 | Bytes x +4 to x +7 for Diagnostic and Process Interrupts | 6-29 |
| 6-9 | Direct Data Exchange with CPUs 41x-2 PCI | 6-31 |
| 6-10 | Diagnostics Address for the Receiver During Direct Data Exchange | 6-32 |
| 7-1 | Clock Synchronization | 7-2 |
| 7-2 | Configuring the Interfaces | 7-4 |
| 7-3 | Setting the PG/PC Interface | 7-5 |
| 7-4 | Installing/Uninstalling Interfaces | 7-7 |
| 7-5 | Starting/Exiting Time Synchronization | 7-8 |
| 7-6 | Setting the Period for Time Synchronization | 7-9 |
| 7-7 | Communication Using Time Synchronization | 7-10 |
| 7-8 | Component Configurator: Assigning Station Names | 7-11 |
| 7-9 | Commissioning wizard: settings for CP 5613 | 7-13 |
| 7-10 | Creating a Project | 7-14 |

| | | |
|------|---|------|
| 7-11 | Selecting a Mounting Rack | 7-15 |
| 7-12 | CP 5613: Properties | 7-16 |
| 7-13 | Configuring the Hardware of the S7-400 Station | 7-17 |
| 7-14 | Bus Connection | 7-19 |
| 7-15 | Enabling Time Synchronization | 7-20 |
| 7-16 | Setting a Period | 7-21 |
| 7-17 | Setting the Synchronization Mode | 7-22 |
| 7-18 | Setting the PG/PC Interface | 7-23 |
| 9-1 | PS Extension Board | 9-2 |
| 10-1 | Memory Card | 10-1 |
| B-1 | Bus Connector: Terminating Resistor Connected and Switched Off | B-7 |
| B-2 | The Terminating Resistor on the RS 485 Repeater | B-7 |
| B-3 | Connecting Terminating Resistors on an MPI subnet | B-8 |
| B-4 | Example of an MPI Subnet | B-9 |
| B-5 | Example of a PROFIBUS Subnet | B-10 |
| B-6 | Example of a Configuration with the CPU 41x-2 DP in an MPI and PROFIBUS Subnet | B-11 |
| B-7 | Cable Lengths in an MPI Subnet | B-14 |
| B-8 | Straight Bus Connector | B-17 |
| B-9 | Stripping Length for Connecting to the Bus Connector (6GK1 500-0EA02) | B-18 |
| B-10 | Connecting the Bus Cable to the Bus Connector | B-19 |
| B-11 | Connecting/Disconnecting the Terminating Resistor | B-19 |
| B-12 | Preparing the PROFIBUS Bus Cable | B-22 |
| B-13 | Optical Isolation | B-23 |
| D-1 | Buttons and Indicators on the Panel Control | D-2 |
| D-2 | Panel Control Properties (General Tab) | D-5 |
| F-1 | Electrostatic Voltages which Can Build Up on a Person | F-3 |

Tables

| | | |
|-----|---|------|
| 1-1 | Components of a PLC Having a PC and a CPU 41x-2 PCI | 1-2 |
| 1-2 | Compatibility / System Requirements | 1-7 |
| 1-3 | Supported operating systems | 1-8 |
| 2-1 | Procedure for Fitting the CPU 41x-2 PCI and the PS Extension Board .. | 2-1 |
| 2-2 | Setting the Switch to Inhibit Battery Monitoring | 2-3 |
| 2-3 | What Happens after Power Up and Power Down of the PC? (without Autoload) | 2-8 |
| 2-4 | When Are the Warm Restart (Restart) and Autoload Functions Possible? | 2-9 |
| 2-5 | Procedure for Connecting the PS Extension Board | 2-10 |
| 2-6 | Terminal Assignment of the External 24 V DC Supply | 2-13 |
| 2-7 | Connector Pin Assignment (Backup Battery) | 2-16 |
| 2-8 | Check List for Checks before Turning on the PC for the First Time | 2-17 |
| 4-1 | Validity of the MPI Parameters Following a Memory Reset | 4-5 |
| 5-1 | LED Displays on the Control Panel | 5-4 |
| 5-2 | Status Displays | 5-5 |
| 5-3 | Error Displays and Special Events | 5-5 |
| 5-4 | Operation of the Controls | 5-8 |
| 5-5 | Startup Types for CPU 41x-2 PCI | 5-9 |
| 5-6 | CPU 41x-2 PCI Protection Levels | 5-10 |
| 6-1 | CPUs 41x-2 PCI (MPI/DP Interface as PROFIBUS-DP) | 6-2 |
| 6-2 | Meaning of "BUSF" LED of CPU 41x-2 PCI as DP Master | 6-6 |
| 6-3 | Reading Out the Diagnostics in STEP 7 | 6-7 |

| | | |
|------|--|------|
| 6-4 | Event Detection of CPUs 41x-2 PCI as DP Master | 6-10 |
| 6-5 | Analysis of RUN/STOP Transitions in the DP Master/DP Slave | 6-10 |
| 6-6 | Configuration Example for the Address Areas of the Transfer Memory . | 6-13 |
| 6-7 | Meaning of the "BUSF" LEDs of CPU 41x-2 PCI as DP Slave | 6-17 |
| 6-8 | Reading Out the Diagnostics in STEP 5 and STEP 7 in the Master System ... | 6-19 |
| 6-9 | Event Detection of CPUs 41x-2 PCI as DP Slave | 6-22 |
| 6-10 | Analysis of RUN/STOP Transitions in the DP Master/DP Slave | 6-22 |
| 6-11 | Structure of Station Status 1 (Byte 0) | 6-24 |
| 6-12 | Structure of Station Status 2 (Byte 1) | 6-25 |
| 6-13 | Structure of Station Status 3 (Byte 2) | 6-25 |
| 6-14 | Structure of the Master PROFIBUS Address (Byte 3) | 6-26 |
| 6-15 | Structure of the Manufacturer's ID (Bytes 4, 5) | 6-26 |
| 6-16 | Event Detection of CPUs 41x-2 PCI as Receivers During Direct Data Exchange | 6-32 |
| 6-17 | Analysis of a Station Failure of the Sender During Direct Data Exchange | 6-33 |
| 10-1 | Differences Between RAM Card and FLASH Card | 10-3 |
| B-1 | Permissible Cable Lengths in an MPI Subnet Segment | B-12 |
| B-2 | Permissible Cable Lengths in a PROFIBUS Subnet Depending on the Transmission Rate | B-12 |
| B-3 | Lengths of Spur Lines per Segment | B-13 |
| B-4 | Network Components | B-15 |
| B-5 | Properties of the PROFIBUS Bus Cable | B-16 |
| B-6 | Specifications for Installation of Indoor Bus Cable | B-16 |
| D-1 | Buttons for Changing the CPU 41x-2 PCI Operating Mode | D-3 |
| D-2 | LED Displays | D-4 |
| D-3 | Connecting a CPU 41x-2 PCI and Changing the Operating Mode | D-6 |
| D-4 | Configuring the Security State for the Panel Control | D-8 |
| D-5 | Responding to Changes in the State of the LED Displays on the Panel Control | D-9 |
| D-6 | Masks for the Panel Control LED Displays | D-10 |

Product Overview

In this chapter

| Section | Contents | Page |
|---------|--|------|
| 1.1 | Components of a PLC Having a CPU 41x-2 PCI | 1-1 |
| 1.2 | Interfaces | 1-4 |

1.1 Components of a PLC Having a CPU 41x-2 PCI

Structure

The figure below shows the configuration of a PLC having a CPU 41x-2 PCI:

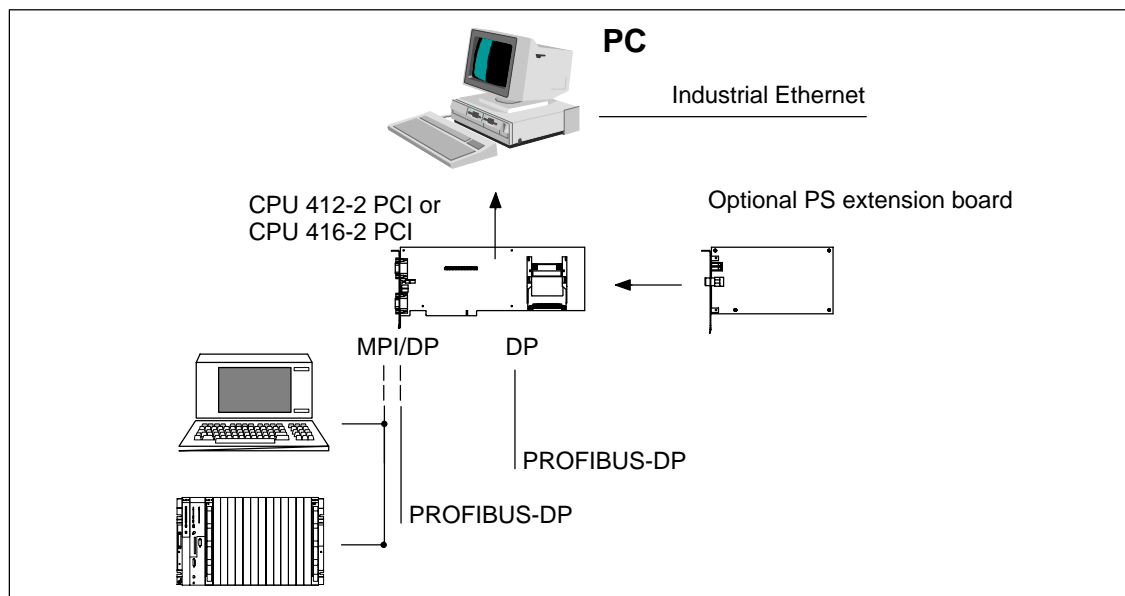

Figure 1-1 Components of a PLC Having a CPU 41x-2 PCI

Components

To configure and commission a CPU 41x-2 PCI, the following components are available:

Table 1-1 Components of a PLC Having a PC and a CPU 41x-2 PCI





| Components | Function | Illustration |
|--|--|---|
| <p>CPU</p> <ul style="list-style-type: none"> • CPU 412-2 PCI • CPU 416-2 PCI | <ul style="list-style-type: none"> • Runs the user program. • Communicates with other CPUs on an MPI network with a programming device through the MPI interface. • Communicates with DP masters and slaves via the DP interface. • Communicates with applications on the PC through the PCI |  |
| <p>PS extension board (PS: power supply)</p> | <p>Additional module for the voltage supply to the CPU 41x-2 PCI, independently of the PC. An external voltage supply and the backup battery can be connected to the PS extension board.</p> |  |
| <p>PC, for example</p> <ul style="list-style-type: none"> • Box PC 620, 820 • Panel PC FI 45, PC 670 • Rack PC RI 45, PC 830 • Standard PC | <p>Houses the CPU 41x-2 PCI. The PC can configure, parameterize and program the CPU 41x-2 PCI if you have installed a STEP 7 package.</p> |  |
| <p>Memory card</p> | <p>Saves the user program and the parameters.</p> |  |
| <p>Programming device (PG) or PC</p> | <p>For configuring, parameterizing, programming and testing the CPU 41x-2-PCI through MPI. A separate programming device is not required to configure the CPU 41x-2 PCI; alternatively, you can configure it with the licensed STEP 7 package at the PC end.</p> |  |
| <p>PROFIBUS bus cable with bus connector</p> | <p>Interconnects stations on an MPI or PROFIBUS subnet</p> |  |
| <p>Programming device cable</p> | <p>Connects the CPU 41x-2 PCI to another programming device or PC through the MPI.</p> |  |

Table 1-1 Components of a PLC Having a PC and a CPU 41x-2 PCI

| Components | Function | Illustration |
|------------------------|--|---|
| RS 485 repeater | For amplifying the signals in an MPI or PROFIBUS subnet and for connecting segments in these systems |  |
| SIMATIC NET components | CP 1613, CP 5613, CP 5611 or 3COM card for connecting the CPU 41x-2 PCI to Industrial Ethernet. |  |

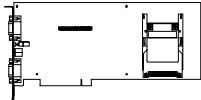
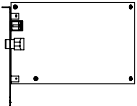
Order number location and version

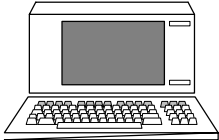
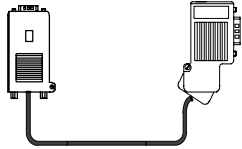
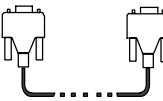
The order number and version are recorded on a label affixed to the module for every CPU 41x-2 PCI. The version is identified by a check mark in each instance.

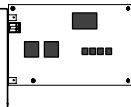
1.2 Interfaces

CPU interfaces

The figure below shows you the interfaces of CPU 41x-2 PCI:

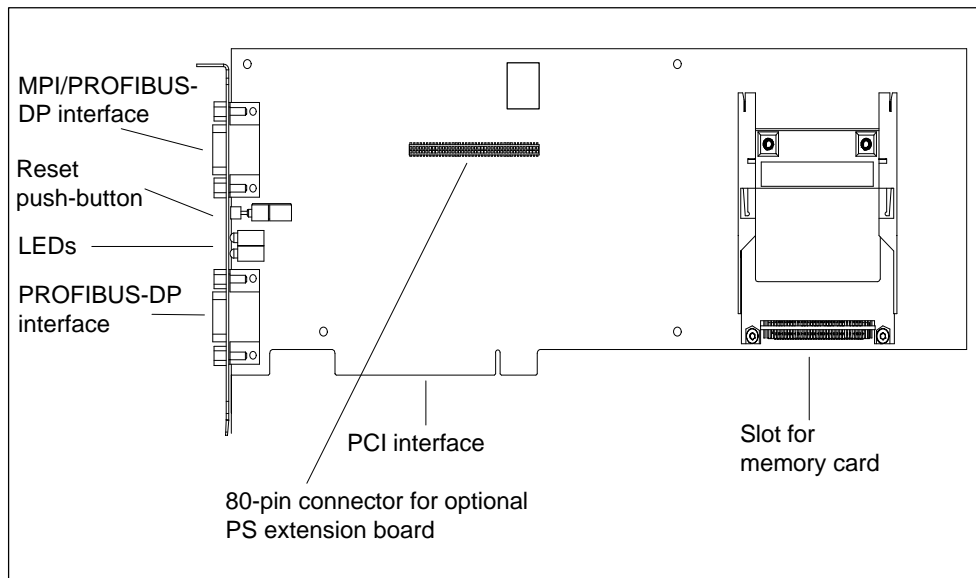

Figure 1-2 CPU 41x-2 PCI

- PROFIBUS-DP interface

The CPU 41x-2 PCI has an integrated PROFIBUS-DP interface. You can connect distributed I/O via this interface.

The CPU 41x-2 PCI can be operated as a DP master or DP slave on PROFIBUS-DP.

- MPI/PROFIBUS-DP interface

You can use the MPI/PROFIBUS-DP interface as an MPI or a PROFIBUS-DP interface (by default it is the MPI).

The multipoint interface (MPI) of the CPU 41x-2 PCI is used to connect to an MPI subnet or for directly connecting an OP or a PC or programming device with STEP 7.

You can also parameterize the MPI as the DP interface. For this purpose you can re-parameterize the MPI under STEP 7 in SIMATIC Manager. This means you can configure a DP line with not more than 32 DP slaves. The starting conditions for the PROFIBUS-DP interface then apply (see higher up).

Note

At the MPI/PROFIBUS-DP interface, pin 7 does not have 24 V for supplying, say, operator panels or remote servicing adapters.

- Slot for memory card

You can insert a memory card in this slot on the CPU 41x-2 PCI. You will find a more detailed description of memory cards in Chapter 10.

- LEDs on the slot plate

Located on the slot plate of CPU 41x-2 PCI are LEDs, in addition to the LED indications on the control panel. The meaning of the LEDs is explained in section 5.3.

- R (RUN)
- S (STOP)
- SF (INTF, EXTF)
- BF (BUSF1, BUSF2)

Interfaces of PS extension board

The figure below shows you the interfaces of the PS extension board:

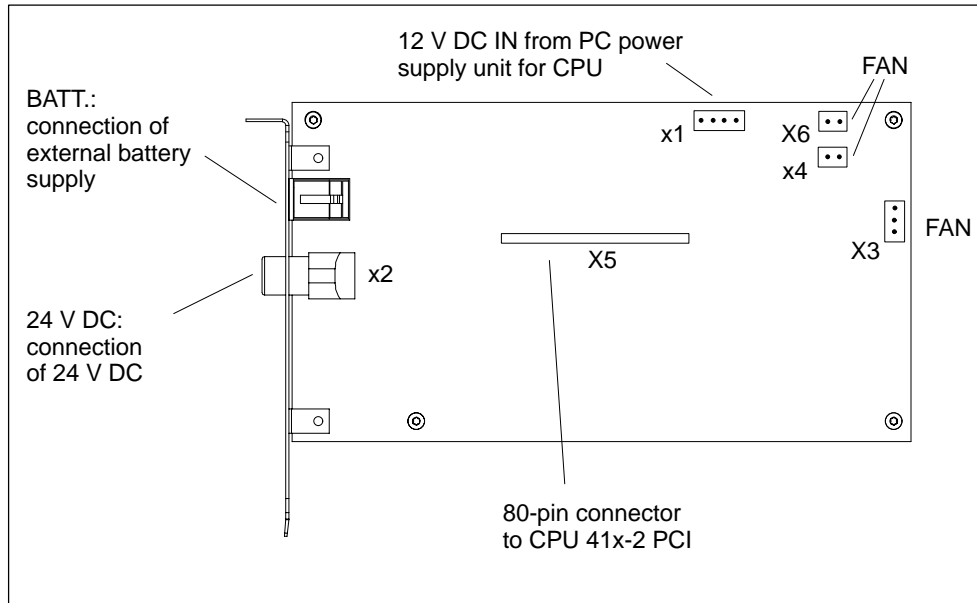

Figure 1-3 PS Extension Board

The PS extension board has the following interfaces:

- Connection of the external 24 V power supply
- Connection of the internal 12 V power supply (from PC)
- Connection of the external backup battery
- Port for PC fan (X3, X4 or X6 – depending on the type of connector)
- Interface to CPU 41x-2 PCI

The PS extension board does not have an interface to the PCI bus.

1.3 Compatibility / System Requirements

The following system requirements should be fulfilled in order to use the new functions of Version 3.3 to the full extent:

- Windows 2000 Professional with SP3 or later or Windows XP Professional with SP1 or later
- STEP 7, V5.2
- Windows 2000/XP computer with at least one free PCI slot with 3/4 length. An additional free adjacent slot is required for the optional PS Extension Board.

See the following table for more details:

Table 1-2 Compatibility / System Requirements

| Used together with | | WinAC Slot 412/416, V3.1 CPU 41x-2 PCI Firmware 1.1.0 PC software version 3.1 | WinAC Slot 412/416, V3.2 CPU 41x-2 PCI Firmware 3.0 PC software version 3.2 | WinAC Slot 412/416, V3.3 (new) CPU 41x-2 PCI Firmware 3.1 PC software version 3.3 |
|--|------------------------------|--|---|---|
| STEP 7 | V5.1, <SP2 | YES | Configuration YES! No communication with SIMATIC NET CP's, No Advanced PC Configuration ¹⁾ | Configuration YES! No communication with SIMATIC NET CP's, No Advanced PC Configuration ¹⁾ |
| | V5.1, SP2 or later | YES | YES | YES, the new functions of the firmware V3.1 are not supported, however |
| | V5.2 or later | YES | YES | YES |
| Operation with SIMATIC NET components | SIMATIC NET CD edition 05/00 | YES | Upgrade to WinAC Slot 41x, V3.1+SP1 required, No new firmware, PC software only | NO |
| | SIMATIC NET CD 07/01 + SP5 | NO Upgrade to WinAC Slot 41x, V3.2 OR use of SIMATIC NET CD 05/00 (see above) | YES | YES Windows 2000 only! |
| | SIMATIC NET CD 11/02 | NO | NO | YES Windows XP only! |
| Microsoft Windows NT4 Workstation SP6 | | YES | YES | NO |
| Microsoft Windows 2000 Professional SP3 | | NO | YES | YES |
| Microsoft Windows XP Professional SP1 | | NO | NO | YES |
| SPARE PART CPU 41x-2 PCI, Firmware 3.1 | | YES | YES | YES |
| Support for WinAC Slot T-Kit, V3.3 | | NO | YES | YES |

¹⁾ Advanced PC Configuration: Configuration of the PC as runtime station.

The configuration of WinAC Slot 412/416 V3.2 can be carried over to WinAC Slot 412/416 V3.3 without restrictions.

In order to use the new functions of WinAC Slot 412/416 V3.3, the new firmware CPU 41x-2 PCI, V3.1 has to be copied from the hardware catalog.

Product version compatibility and supported operating systems:

The table shows which WinAC Slot PC software versions can be used in combination with specific versions under various Microsoft operating systems. The delivery packages of the original product versions V3.2 and V3.3 are shown with a gray background. The unmarked table rows indicate the possible compatible combinations of the various product versions that can occur in a plant.

Table 1-3 Supported operating systems

| Firmware Version of the WinAC Slot Module | WinAC Slot 412/416 PC Software CD | Microsoft Windows NT4 Workstation SP6 | Microsoft Windows 2000 Professional SP3 | Microsoft Windows XP Professional SP1 |
|--|-----------------------------------|---------------------------------------|---|---------------------------------------|
| V3.0 | V3.1 SP1 | YES | NO | NO |
| V3.0 | V3.2 | YES | YES | NO |
| V3.0 | V3.3 | NO | YES | YES |
| V3.1 | V3.1 SP1 | YES | NO | NO |
| V3.1 | V3.2 | YES | YES | NO |
| V3.1 | V3.3 | NO | YES | YES |

The new product version WinAC Slot 412/416 V3.3 is fully upwards compatible. If you wish to use Microsoft Windows NT4 Workstation, you can use product version SIMATIC WinAC Slot 412/416 V3.2, which continues to be available.

Installing a CPU 41x-2 PCI and PS Extension Board

2

In this chapter

This chapter describes how you install a CPU 41x-2 PCI and the PS extension board on a PC.

| Section | Contents | Page |
|---------|---|------|
| 2.1 | Fitting a CPU 41x-2 PCI and PS Extension Board | 2-1 |
| 2.2 | Connecting a CPU 41x-2 PCI and PS Extension Board to the Voltage Supply | 2-6 |
| 2.3 | Installing and Connecting the Backup Battery | 2-14 |
| 2.4 | Checks Before Initial Turn-on of the PC with CPU 41x-2 PCI | 2-17 |

2.1 Fitting a CPU 41x-2 PCI and PS Extension Board

Procedure

The following table shows you the basic procedure for fitting the CPU 41x-2 PCI and PS extension board.

Table 2-1 Procedure for Fitting the CPU 41x-2 PCI and the PS Extension Board

| Step | Procedure | Refer to Section... |
|------|---|---------------------|
| 1. | Turn Off the PC and Open it | 2.1.1 |
| 2. | Set Battery Monitoring | 2.1.2 |
| 3. | Screw the PS Extension Board to the CPU 41x-2 PCI | 2.1.3 |
| 4. | Insert the Memory Card | 2.1.4 |
| 5. | Plug the CPU 41x-2 PCI into the PC | 2.1.5 |

Requirements

Please note the following requirements before you install the CPU 41x-2 PCI and the PS extension board.

- The CPU 41x-2 PCI requires a PCI slot at the default distance.
- If you use the CPU 41x-2 PCI together with a PS extension board, you will require two adjacent vacant slots, the PS extension board not being connected to the PCI bus.

Note

Some PCs with PCI/ISA combi slots have their housing cutouts on the slot plate for ISA plug-in cards. If you use the CPU 41x-2 PCI together with a PS extension board in a PCI/ISA combi-slot, the PS extension board is located above an ISA slot and uses an ISA housing cutout. Problems can then occur on many PCs with regard to the fit between the slot plate of the PS extension board and the associated PC housing cutout.

2.1.1 Turn Off the PC and Open it



Caution

The electronic components on the printed circuit boards are extremely susceptible to electrostatic discharges. Observe the rules for handling electrostatic sensitive devices (refer to the ESD Guidelines in Appendix F).

1. Turn your PC off, and remove the mains plug from the rear panel.
2. Open the PC as described in the manual for the device.

2.1.2 Set Battery Monitoring

3. Set whether you want to inhibit battery monitoring at switch 1 on the CPU 41x-2 PCI. It is sensible to inhibit battery monitoring if you do not insert a battery. If that were the case, the "BATF" LED on the control panel would be permanently on even though you were not using a battery.

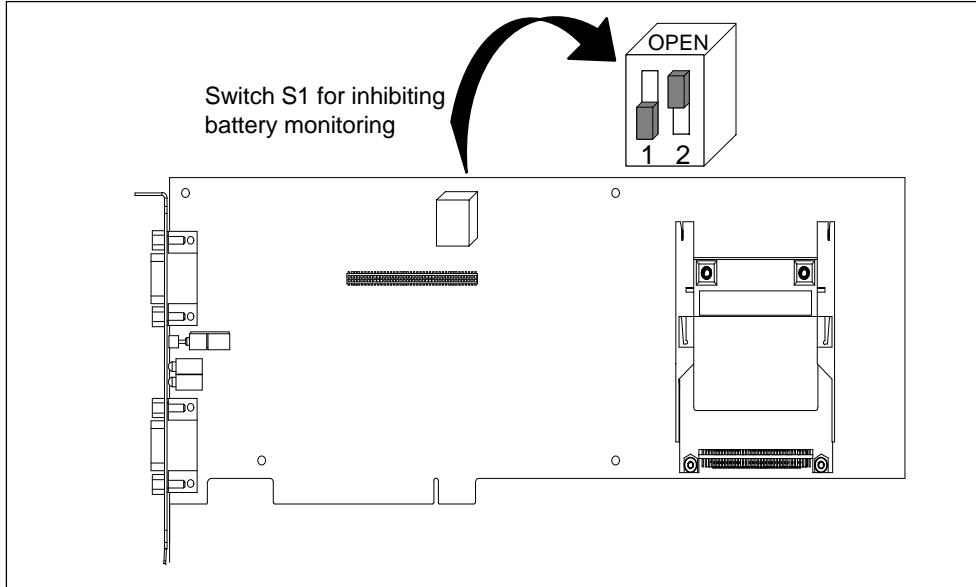



Figure 2-1 Position of the Switch on CPU 41x-2 PCI

Table 2-2 Setting the Switch to Inhibit Battery Monitoring

| If You ... | Then | Switch Setting |
|----------------------------------|---------------------------------------|---|
| Do not use a PS extension board | Set switch 1 to the OPEN position |  |
| Do not use battery monitoring | | |
| Use battery monitoring (default) | Set switch 1 to the NOT OPEN position |  |

2.1.3 Screw the PS Extension Board to the CPU 41x-2 PCI

Using a PS extension board:

You will require the PS extension board

- for the Restart function
- when data remanence is required after power down (including power failure), or
- when operation of the CPU 41x-2 PCI independently of the PC and in conjunction with an external power supply (24 V) is required.

Screwing the PS extension board

4. Insert the PS extension board in the CPU 41x-2 PCI and screw the two modules together.

Note

When inserting the PS extension board into the CPU 41x-2 PCI, make absolutely sure that you plug in the 80-pin connector correctly on the module without bending any of the pins.

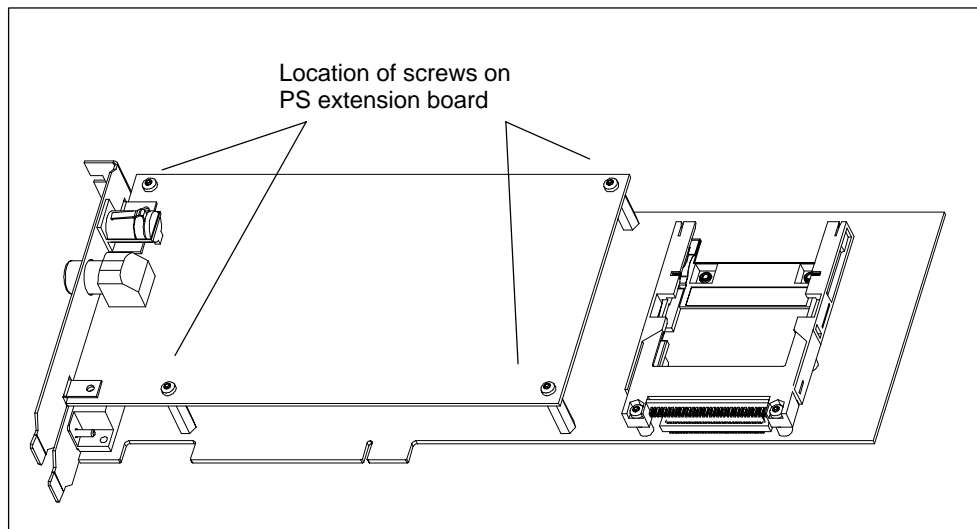

Figure 2-2 Screwing the CPU 41x-2 PCI to the PS Extension Board

2.1.4 Insert the Memory Card

5. Insert the memory card.

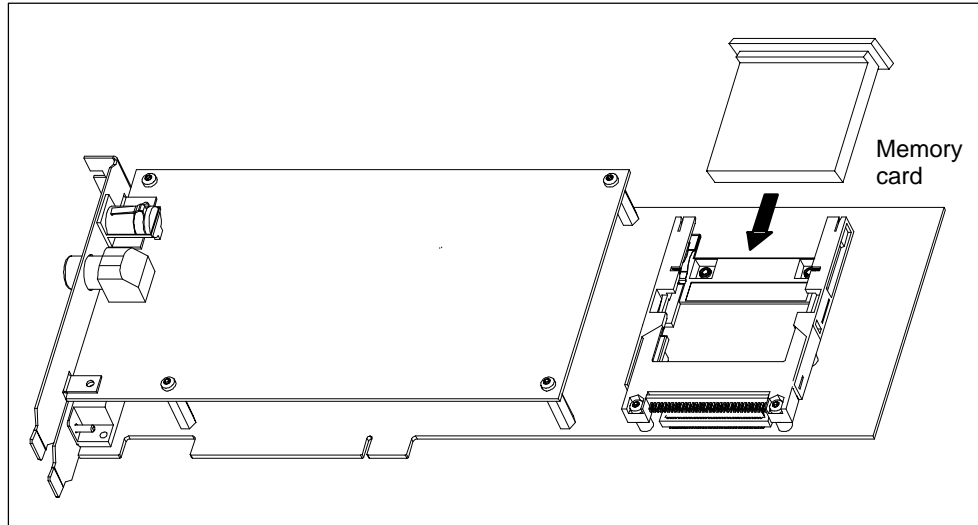

Figure 2-3 Inserting a Memory Card in a CPU

2.1.5 Plug the CPU 41x-2 PCI into the PC

6. Insert the CPU 41x-2 PCI into a vacant PCI slot on the motherboard.
7. Screw the CPU 41x-2 PCI and the PS extension board, as necessary, to the PC rear panel.

2.2 Connecting a CPU 41x-2 PCI and PS Extension Board to the Voltage Supply

In this chapter

| Section | Contents | Page |
|---------|--|------|
| 2.2.1 | Important Information | 2-7 |
| 2.2.2 | Procedure for Connecting the PS Extension Board | 2-10 |
| 2.2.3 | Connecting the PS Extension Board to 12 V DC from the PC Power Supply | 2-11 |
| 2.2.4 | Connecting the PS Extension Board to an External 24 V DC Supply (Optional) | 2-12 |
| 2.2.5 | Connecting the PS Extension Board to a Fan | 2-13 |

2.2.1 Important Information

Introduction

The sections that follow contain decision-making aids for you, such as how to connect the CPU 41x-2 PCI to the power supply. Depending on the type of power supply and the settings in the “Startup Type” and “Autoload” dialog boxes (refer to Section 5.5), the startup behavior of the CPU 41x-2 PCI will vary.

Do you not want...

- **data remanence after turning off the PC?**

... then use the CPU 41x-2 PCI without the PS extension board.

You have the option of storing the STEP 7 user program in a memory card file on the PC and loading this file automatically after power up into the CPU 41x-2 PCI (“Autoload” function).

- **data remanence after turning off the PC?**

... then use the CPU 41x-2 PCI with the PS extension board and the backup battery.

The CPU 41x-2 PCI does not depend on the PC for as long as the power supply unit of the PC is working – in other words, a warm restart of the PC does not affect operation of the CPU 41x-2 PCI.

When the PC is turned off, the CPU 41x-2 PCI stores the current values of the STEP 7 user program in such a way that a warm restart (restart)/complete is possible after the PC has been powered up.

- **to operate the CPU 41x-2 PCI independently of the PC?**

... then use the CPU 41x-2 PCI with the PS extension board (including backup battery) and connect the CPU to the an external 24 V DC supply, too. In this case you can turn off the PC – the CPU 41x-2 PCI carries on running!

The CPU 41x-2 PCI is independent of the PC. The PC can be powered down or fails, and the CPU 41x-2 PCI continues to tun (uninterrupted transfer of the voltage supply). Here again, a warm restart (restart)/complete restart is possible.

Note

You will find additional, detailed information on the next two pages and in Appendix C! Appendix C is also where you will find answers to frequently asked questions, especially about the PS extension board.

Startup behavior of the CPU 41x-2 PCI following PC POWER UP of the PC

Depending on how you connect the CPU 41x-2 PCI to the power supply, the startup response of the CPU 41x-2 PCI varies after the PC has powered up. The startup response of the CPU 41x-2 PCI following POWER UP of the PCs depends on several factors:

- operation with or without a PS extension board
- battery backup available or not available
- external 24 V DC voltage supply to PS extension board connected or not
- type of memory card (FLASH card or RAM card)

Depending on the above-mentioned points, the following scenarios result:

Table 2-3 What Happens after Power Up and Power Down of the PC? (without Autoload)

| PS Ext. board | Ext. 24 V DC | Backup bat. | What happens after Power Up and Power Down of the PC? |
|---------------|--------------|-------------|--|
| No | – | – | With POWER DOWN of the PC, the CPU 41x-2 PCI loses the voltage supply – there is no backup voltage. Any user program on the FLASH card is retained. All the contents of the RAM (work and integrated load memory, RAM card) are lost. Following POWER UP of the PC, the mode switch is set to STOP. The CPU 41x-2 PCI performs an automatic memory reset and remains at STOP (cold restart). |
| Yes | No | No | With POWER DOWN of the PC, the CPU 41x-2 PCI loses the voltage supply – there is no backup voltage. Any user program on the FLASH card is retained. All the contents of the RAM (work and integrated load memory, RAM card) are lost. Following POWER UP of the PC, the mode switch is set to STOP. The CPU 41x-2 PCI performs an automatic memory reset and remains at STOP (cold restart). |
| | No | Yes | With POWER DOWN of the PC, the CPU 41x-2 PCI saves the necessary data for it to restart. The contents of the RAM are not lost. Following POWER UP of the PC, the CPU 41x-2 PCI performs a warm start (restart) or complete restart, or remains at STOP, depending on the parameter assignment and setting of the mode switch. |
| | Yes | Yes/No | The CPU 41x-2 PCI continues to run irrespective of POWER DOWN/ POWER UP of the PC. |

When are the warm restart (restart) and Autoload functions possible?

Warm restart (restart)

A warm restart (restart) following the PC being powered up is possible only with the PS extension board and backup battery.

Autoload

If you are not using the PS extension board, you can load user data by means of the “Autoload” function (refer to Section 5.5).

With the “Autoload” function, the PC automatically fetches a STEP 7 user program (stored in a memory card file) following power down and power up and loads it onto the CPU 41x-2 PCI. Following that, the CPU 41x-2 PCI automatically selects the status that it had stored beforehand and, depending on the status, the STEP 7 user program is executed.

Table 2-4 When Are the Warm Restart (Restart) and Autoload Functions Possible?

| PS extension board | Ext. 24 V DC supply | Backup battery | Memory card | Warm restart (restart) possible after complete restart following power up of the PCs? | Autoload function possible? |
|--------------------|---------------------|----------------|---------------|---|-----------------------------|
| No | – | – | RAM card/none | No | Yes |
| | | | FLASH Card | No | No |
| Yes | No | No | RAM card/none | No | Yes |
| | | | FLASH Card | No | No |
| | No | Yes | RAM card/none | Yes | No |
| | | | FLASH Card | Yes | No |
| | Yes | No | RAM card/none | Irrelevant* | Yes |
| | | | FLASH Card | Irrelevant* | No |
| | Yes | Yes | RAM card/none | Irrelevant* | No |
| | | | FLASH Card | Irrelevant* | No |

* CPU 41x-2 PCI continues to be supplied from the external 24 V DC source.

2.2.2 Procedure for Connecting the PS Extension Board

Procedure

The required startup response (refer to Section 2.2.1) determines how you connect the PS extension board.

Table 2-5 Procedure for Connecting the PS Extension Board

| Step | Procedure for operating the CPU 41x-2 PCI with the PS extension board | Refer to Section... |
|------|--|---------------------|
| 1. | Connect the PS extension board to 12 V DC from the PC power supply (mandatory) | 2.2.3 |
| 2. | Connect the PS extension board to an external 24 V DC supply (optional) | 2.2.4 |
| 3. | Connect the PS extension board to the fan of the PC (mandatory) | 2.2.5 |

Position of the cable connector on the PS extension board

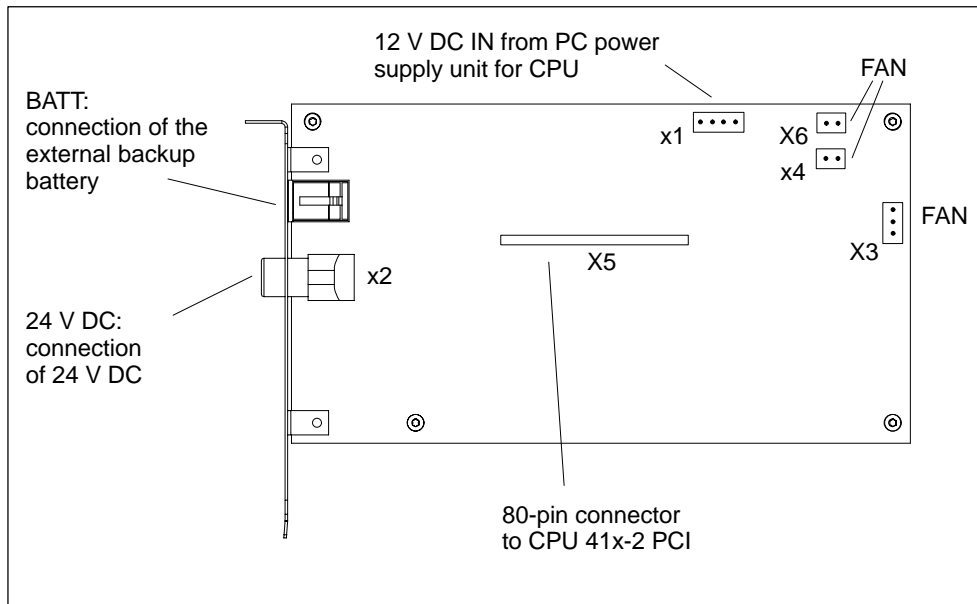

Figure 2-4 Position of Cable Connectors on PS Extension Board

2.2.3 Connecting the PS Extension Board to 12 V DC from the PC Power Supply

Box PC 620 or Panel PC 670: connect the PS extension board to 12 V DC from the PC power supply

1. Disable the fan regulation in the BIOS setup (Main → Hardware Options → Fan Control → disabled).
2. Unplug the 2-pin housing fan connector from the PC motherboard (located between the processor and the battery).
3. Plug it onto connector X6 on the PS extension board.
4. Plug the 2-pin socket of the enclosed 12 V power supply cable onto the connector on the PC motherboard that became unassigned in 1. above.
5. Plug the other end of the enclosed 12 V power supply cable (4-pin socket) onto connector X1 (DC12V IN) on the PS extension board.

The following photograph shows the locations of the connections used:

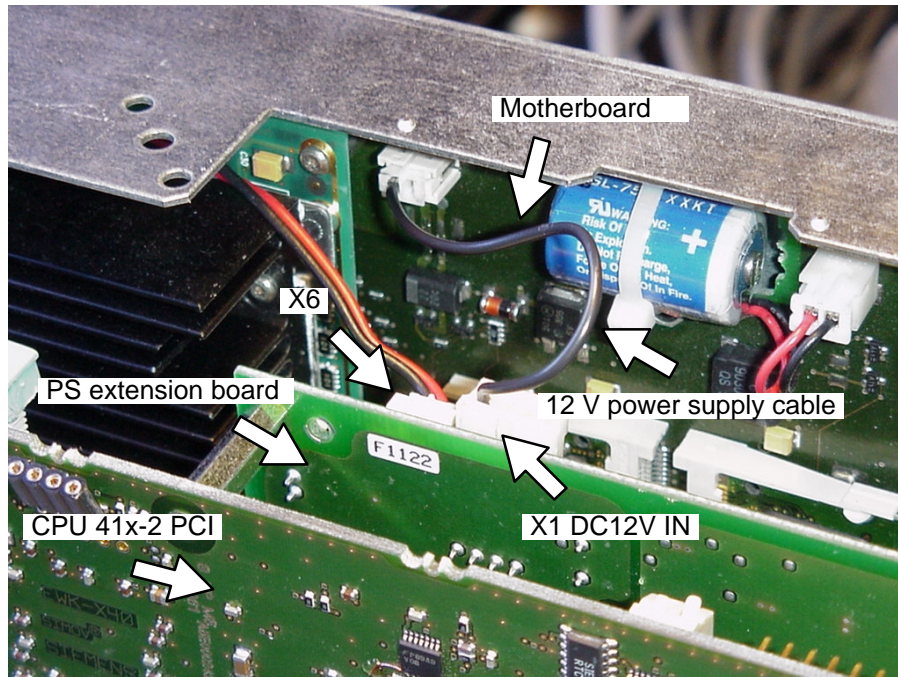

Figure 2-5 Box PC 620/Panel PC 760: Connectors for Connection to 12 V DC from PC Power Supply

Other PCs: connect the PS extension board to external 12 V DC source from PC power supply

1. Plug one of the supply connectors from the PC onto connector X1 on the PS extension board.

If the cable from the supply connector is too short or if no supply connector is available any more on the PC, insert the Y-cable (included in the PS extension board package). By using the Y-cable, you do not lose any supply connector of the PC for other applications.

2.2.4 Connecting the PS Extension Board to an External 24 V DC Supply (Optional)

Requirements for connection to external 24 V DC

For the CPU 41x-2 PCI and the PS extension board, the whole supply with 24 V DC has to be generated as a safety extra-low voltage (SELV).



Warning

Personal injury or material damage can result.

If you do not design the 24 V DC supply of the PS extension board correctly, components can be damaged and individuals may be injured.

The 24 V DC supply must satisfy the following requirements:

Only the extra-low voltage ≤ 60 V DC, properly isolated from the mains, can be used as the load current power supply. Proper isolation can be implemented in accordance with the requirements, among others, of VDE 0100, Part 410 / HD 384-4-41 / IEC 364-4-41 (as functional extra-low voltage with proper isolation) or VDE 0805 / EN 60950 / IEC 950 (as safety extra-low voltage, SELV) or VDE 0106, Part 101.

Connecting the PS extension board to an external 24 V DC supply

1. **Connecting to an external 24 V DC voltage supply (optional):** In the PS extension board package there is a 3-core cable having a connector with push/pull locking against inadvertent removal.

Plug the 3-pin connector onto connector X2 on the slot plate of the PS extension board.
2. Connect the cable for the 24 V DC supply to the voltage supply as shown in Table 2-6.

Table 2-6 Terminal Assignment of the External 24 V DC Supply

| Contact | Color |
|---------|-------|
| L+ | Red |
| M | Black |
| PE | Brown |

Cable for connection of 24 V DC to PS extension board

The cable contained in the package is 1.5 m long.

The following initial condition must be observed when this cable is used:

- < 2 m: minimum diameter of stranded wire 0.5 mm
- > 2 m: minimum diameter of stranded wire 0.75 mm (refer to UL 1950, Section 3.2.4, Table 11)

2.2.5 Connecting a Fan to the PS Extension Board

You must connect the fan on the PC to the PS extension board. When the PC fails or is turned off and the PS extension board is connected to an external 24 V DC supply voltage, the CPU 41x-2 PCI continues to be cooled by the fan.

Authorized PC fans

Only UL, CSA certified fans are authorized within their technical specifications.

Connection options

The PS extension board has three connection options for the fan of the PC (X3, X4 or X6) – depending on the type of connector. Terminals X3, X4 and X6 together provide 300 mA at 12 V. Terminals X3, X4 and X6 can be operated in parallel, too.

1. Remove the connector that is connected to the fan from the motherboard or power supply and connect the connector to X3, X4 or X6.

2.3 Installing and Connecting the Backup Battery

Affixing the battery holder

There are several ways in which you can attach the backup holder in a battery holder on the PC :

- Install the battery holder instead of a free slot plate on the PC
- Fix the battery holder to the PC housing
- **Box PC 620 and 820:** Fix the battery holder to the PC



Warning

When opening the PC, make absolutely certain you follow the relevant safety information in the manual for the PC.



Warning

For safety reasons, the lithium battery must be attached in an area protected against mechanical impairment.

Battery holder on slot plate

You can insert the backup battery with the battery holder supplied with it (slot plate with hood) in place of a vacant slot plate on the PC (see figure below).

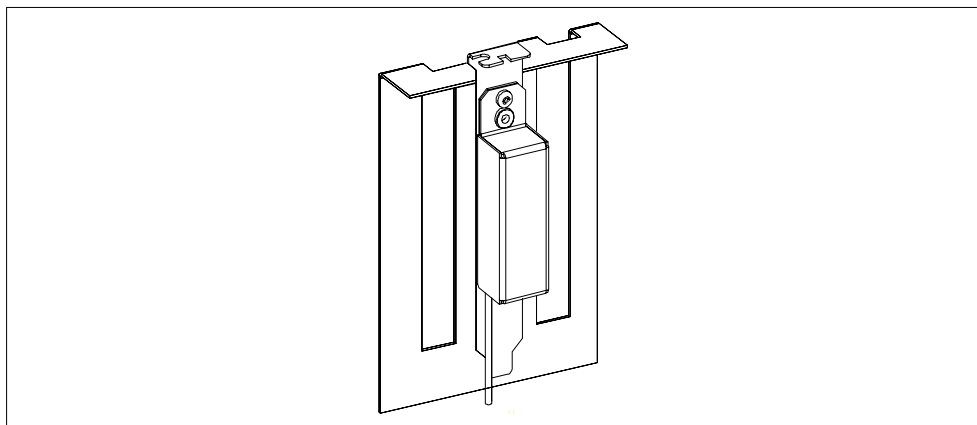

Figure 2-6 Slot Plate with Hood

Battery on PC housing

Alternatively, you can attach the backup battery directly to the PC housing. To do this, screw the battery casing from the slot plate and seal it with the enclosed plate (see figure below). Attach the sealed battery case with double-sided adhesive tape to the PC housing such that the interconnecting cable just reaches the CPU 41x-2 PCI.

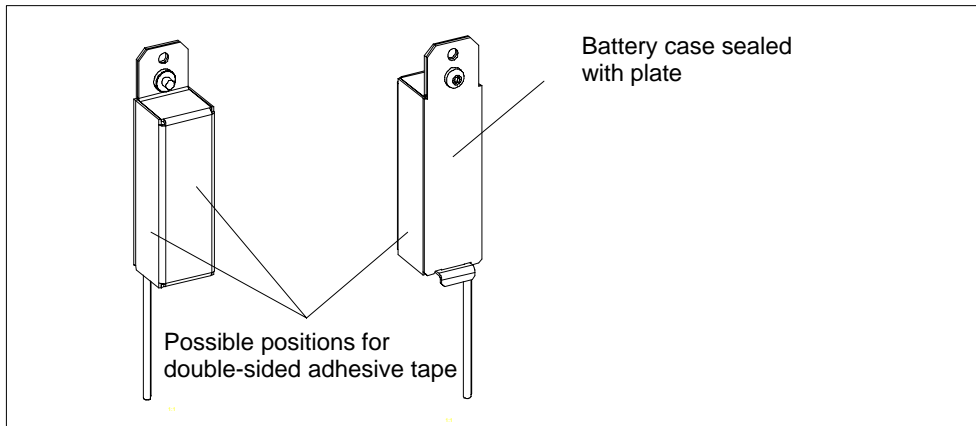

Figure 2-7 Plate for Battery Holder on PC Housing

Connecting the external backup battery supply

Figure 2-8 shows the position of this interface on the slot plate.

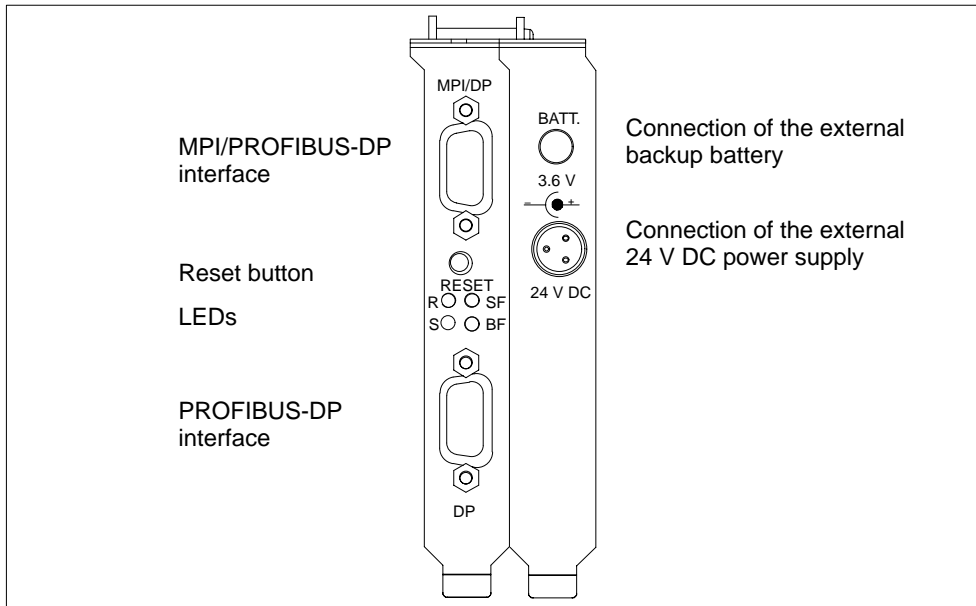

Figure 2-8 Interfaces

A lithium battery (type AA, 3.6 V cell voltage) is used for the standby power supply to the CPU 41x-2 PCI.

A battery pack with a suitable backup battery in a prewired battery holder is supplied in the WinAC Slot 41x package.

For the incoming supply, there is a 2-pin 4.95 mm socket on the slot plate of the PS extension board. This socket is available for an SO connector without sliding sleeve to DIN 45323 for connecting external power supplies for battery-powered devices.

However, its assignment does not conform to DIN – in other words, the inner contact is the positive pole and the outer contact is the negative pole. As a result, there cannot be a short-circuit with the CPU slot plate when removing or inserting the connector to the backup battery.

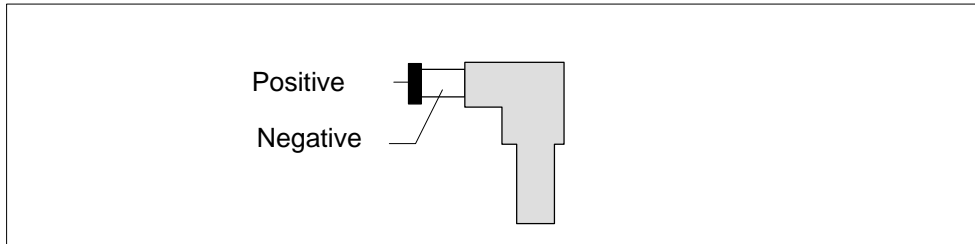

Figure 2-9 2-Pin 4.95 mm Coaxial Connector to Backup Battery

Table 2-7 Connector Pin Assignment (Backup Battery)

| Contact | Assignment |
|---------|-----------------------|
| Inner | Battery, positive |
| Outer | Battery, negative (M) |

For information on connecting the backup battery refer to section 4.4.

2.4 Checks before Initial Turn-On of the PC with CPU 41x-2 PCI

Introduction

After installing and wiring your CPU 41x-2 PCI, we recommend that you check the steps you have performed so far before you turn on your PC for the first time.

Checks prior to initial power up

Table 2-8 provides instructions for checking your automation system in the form of a check list.

Table 2-8 Check List for Checks before Turning on the PC for the First Time

| Check the following items |
|--|
| Has the CPU 41x-2 PCI been properly inserted and screwed tight? |
| Has a memory card been inserted? |
| When using a PS extension board: <ul style="list-style-type: none"> • Has the 80-pin connector between the CPU 41x-2 PCI and the PS extension board been properly inserted? • Has the PS extension board been screwed to the CPU 41x-2 PCI? • Has the PS extension board been connected to the PC power supply unit? • Is the PC fan connected to the PS extension board? • Has the connector for feeding in the external power supply been properly wired? • Has the backup battery been connected? |
| Has the switch for battery monitoring been properly set? |
| Have the slot plates been screwed to the PC? |

Close the PC as described in your manual.

Installing WinAC Slot 41x

In this chapter

| Section | Contents | Page |
|---------|---|------|
| 3.1 | Installing the WinAC Slot 41x Software | 3-1 |
| 3.2 | Component Configurator: Configure PC Components within the PC | 3-4 |
| 3.3 | Uninstalling the WinAC Slot 41x Software | 3-6 |

3.1 Installing the WinAC Slot 41x Software

The WinAC Slot 41x software features separate setup features for the CPU 412-2 PCI and the CPU 416-2 PCI, together with the other software components (control panel, SIMATIC Computing, Tool Manager, and time synchronization).

System requirements

For installing the components of WinAC Slot 41x, we recommend the following requirements for your computer:

- A personal computer (PC) with the following:
 - Pentium processor running at 300 MHz or faster
 - Not less than 128 MB RAM
 - Microsoft Windows 2000 Professional, SP 3 or later or Microsoft Windows XP Professional, SP 1 or later.
- A color monitor, keyboard, and mouse (or other pointing device) that are supported by Microsoft Windows
- A hard disk with at least 120 MB of spare storage space
- At least 60 Mbyte free memory capacity on drive C for the Setup program (Setup files are deleted when the installation is complete)
- 1 PCI slot for 3/4-length cards at standard spacing and one adjacent vacant slot for an optional PS extension board.

Requirements

Before you can install a software package, the following requirements must be met:

- Windows 2000 Professional or Windows XP Professional must be installed.
- You have logged on with administrator privileges. If not, important entries in the Windows registry cannot be made effectively and the installation will remain incomplete.

If an earlier version of WinAC Basis or WinAC Pro has been installed,

you must uninstall any older versions before installing the new version. Refer to section 3.3 for information.

Order of installation

When installing the different software packages, we recommend that you install them in the following order:

1. Install the following components using the general setup
 - control panel (minimum)
 - time synchronization, if you want to synchronize the CPU 41x-2 PCI using a SIMATIC CP
 - SIMATIC Computing, if you want to use ActiveX Controls or OPC
2. STEP 7, as necessary
3. WinCC or ProTool/Pro, as necessary
4. Network components, as necessary.

Installing the components of WinAC Slot 41x

The WinAC Slot 41x software includes a setup feature that performs automatic installation.

The Setup program guides you step by step through the installation process. You can switch to the next step or to the previous step from any position. To start the installation program, proceed as follows:

1. Insert the CD in your CD-ROM drive.
2. Double-click the "setup.exe" file to select it.
3. Follow the instructions until Figure 3-1 is displayed.

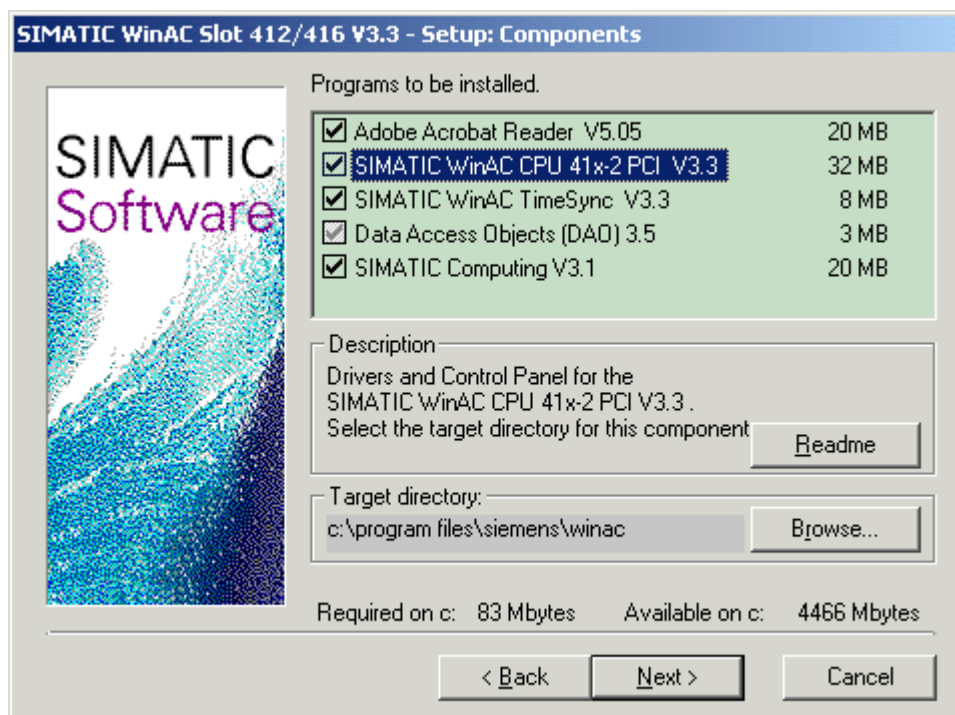

Figure 3-1 Installing the Components of WinAC Slot 41xx

4. Select the components that you want to install. Setup automatically highlights the components that it could not find on your PC.

Once the installation has been completed successfully, a message to that effect is displayed on the screen.

Troubleshooting any errors that occur during installation

The following errors will result in installation being aborted:

- **Inadequate memory:** you require at least 120 MB of space on your hard disk.
- **Defective CD:** if you establish that the CD is defective, please contact your local Siemens agent.

3.2 Component Configurator: Configure PC Components within the PC

Function of the component configurator

You notify the following settings to the PC with the help of the component configurator:

- Station name,
- Type of CPU 41x-2 PCI and
- Name of CPU 41x-2 PCI.

Note

The settings in the component configurator must match the subsequent configuration in "STEP 7/Configure Hardware":

- Station name
 - Type
 - Index (corresponds to the slot in "Configure Hardware") and
 - Name.
-

Index

The CPU 41x-2 PCI is automatically operated on index 3. The index corresponds to a virtual slot on the PC.

Name

Note

The name that you assign to the CPU 41x-2 PCI in the component configurator then corresponds to the name by which you call the control panel of the CPU from the taskbar. If, for example, you assign the name Slot_CPU to the CPU 41x-2 PCI, call the control panel at **Start > Simatic > PC Based Control > Slot_CPU**.

Information about the component configurator

You will find more information about diagnostics in the component configurator, for example, in the appropriate online Help.

Procedure

To assign the name to the PC

1. Open the component configurator by clicking on the

button  on the taskbar.

3.3 Uninstalling the WinAC Slot 41x Software

Observe the following points before you start to uninstall:

- The corresponding software components must not be in use when the software is uninstalled.

Uninstalling the components of the WinAC Slot 41x software

Perform the following steps to remove the WinAC Slot 41x software from your computer:

1. Double-click on the “Software” icon on the Control Panel.
2. Select one of the WinAC Slot 41x components you want to have uninstalled from the list of installed software. Click the “Add/Remove” button to uninstall the software.
3. If the “Remove Enable Files” dialog box appears, click the “No” button if you are unsure how to respond.

Note

Study the Readme files of the software components concerned.

Commissioning

4

In this chapter

| Section | Contents | Page |
|---------|--|------|
| 4.1 | Points to Note when Integrating the Software | 4-1 |
| 4.2 | Recommended Procedure for Commissioning | 4-2 |
| 4.3 | Resetting the CPU with the Mode Switch | 4-4 |
| 4.4 | Connecting a Backup Battery (Option) | 4-5 |
| 4.5 | Reset Button: Resetting the Module | 4-8 |

4.1 Points to Note when Integrating the Software

Module state

The "Module State" window displays order number 6ES7 612-2QH00-0AB4 for the CPU 412-2 PCI and order number 6ES7 616-2QL00-0AB4 for the CPU 416-2 PCI. Note that you can only purchase the CPU 41x-2 PCI as a spare part using these order numbers.

Configuring STEP 7 hardware

You configure a CPU 41x-2 PCI in SIMATIC Manager by choosing **Insert > Station > SIMATIC PC Station from the menu.**

In Step 7/Configure Hardware select for the

- CPU 412-2 PCI: **SIMATIC PC Station > Controller > CPU 412-2 PCI > 6ES7 612-2QH00-0AB4 > V3.1** or
- CPU 416-2 PCI: **SIMATIC PC Station > Controller > CPU 416-2 PCI > 6ES7 616-2QL00-0AB4 > V3.1.**

A configured CP is not displayed following an upload of a configuration from a CPU 41x-2 PCI.

Reserved address area for a technological application



Caution

In the CPU 412-2 PCI, PEW 4096 to 8190 and PAW 4096 to 8190 – in the CPU 416-2 PCI the PEW 16384 to 20478 and PAW 16384 to 20478 – are reserved for a technological application.

If you access the above address area in your STEP 7 user program, an I/O access error is not generated, irrespective of whether or not a technological function is being operated in this area.

4.2 Recommended Procedure for Commissioning

Introduction

Due to the fact that there are so many expansion options, a PC-based automation system with the CPU 41x-2 PCI can be very large and complex. We recommend that you commission your device step by step by

1. Commissioning the PC and the CPU 41x-2 PCI, followed by
2. Commissioning the connected I/O

After you have installed your CPU 41x-2 PCI on the PC and performed the checks described in section 2.4, you can turn on your PC.

Commissioning a PC with a CPU 41x-2 PCI

To commission a PC having a CPU 41x-2 PCI, we recommend that you perform the following steps:

1. Make sure once more that you have properly installed and parameterized the CPU 41x-2 PCI (refer to the check list in section 2.4).
2. Disconnect any DP line that is connected.
3. Turn on the PC.
4. Open the control panel:

Start > Simatic > PC Based Control > CPU 412-2 PCI or
Start > Simatic > PC Based Control > CPU 416-2 PCI

Note

It is assumed in the following that you have saved the CPU 41x-2 PCI in the component configurator as "CPU 412-2 PCI" or "CPU 416-2 PCI".

5. The following LEDs light on the control panel:

- the green LED ON
- the yellow LED STOP

Check the backup battery and the position of switch S1 to inhibit battery monitoring if the red LED BATF is also on.

Up-to-date information about the control panel is stored in a readme file. You can open these readme files in the following directory:

Start > Simatic > Product Notes > English

Should error messages be output to the screen when installing the control panel, read the Readme file before taking any further action.

6. Press the RUN button on the control panel.

You are then prompted to enter your password. The default password for the control panel is "" (no password or RETURN).

Once you have entered your password, the LEDs STOP and RUN light. The CPU is now in RUN mode.

7. Press the STOP button on the control panel.

The RUN LED goes out, and the STOP LED lights. The CPU is now in STOP mode.

8. If you are using a PS extension board and want to check out the internal supply by means of the PC power supply unit, you can detach the external voltage supply and check whether the CPU 41x-2 PCI continues to operate.

9. Connect the CPU 41x-2 PCI step by step to the other components.

4.3 Resetting the CPU with the Mode Switch

Introduction

When you reset a CPU, you return the CPU memory to a defined initial state. Furthermore, the CPU initializes its hardware parameters and some of the system program parameters. If you have inserted a FLASH card with a user program in the CPU, the CPU transfers the user program and the system parameters stored on the FLASH card to the CPU work memory subsequent to a reset operation.

When do you reset the CPU memory?

- When the CPU prompts you to reset, you must perform resetting from the control panel. You will recognize this prompt from the fact that the STOP LED flashes slowly at 0.5 Hz.
- We recommend a complete reset before you transfer a new, complete user program to the CPU.

How do you reset?

There are two ways of resetting the CPU memory:

- From the control panel (MRES)
- Via STEP 7

Resetting process in the CPU

The following procedure is performed in the CPU during a reset operation:

- The CPU deletes the whole user program from the work memory and load memory (integrated RAM and possibly RAM card).
- The CPU deletes all counters, memory markers and timers (apart from the time of day).
- The CPU tests its own hardware.
- The CPU initializes its hardware and system program parameters – in other words, internal CPU (default) settings. Some assigned default settings are retained.
- If there is no FLASH card plugged in, a reset CPU will have a reset state of "0". You can read out the state in STEP 7.
- If you have inserted a FLASH card, the CPU copies the user program and the system parameters stored on the FLASH card to the work memory after a reset has been performed.

What is retained after resetting?

After the CPU has been reset, the following data are retained:

- The contents of the diagnostic buffer (you can read out the contents in STEP 7).
- The MPI parameters (MPI address and highest MPI address). Note the special features in Table 4-1.
- The time of day

Special feature: MPI parameter

The MPI parameters are an exception in a reset operation. The MPI parameters valid after a memory reset are described in Table 4-1.

Table 4-1 Validity of the MPI Parameters Following a Memory Reset

| Memory Reset | MPI Parameters ... |
|-----------------------------|--|
| With FLASH card inserted | ..., located on the FLASH card are valid |
| Without FLASH card inserted | ..., are retained in the CPU and are valid |

4.4 Connecting a Backup Battery (Option)

Requirement

The battery voltage is fed in on the PS extension board. This means that if you are **not using** a PS extension board, you **cannot use** a backup battery.

Using a backup battery

You must use a backup battery:

- To back up a user program that you wish to save in RAM so that it is powerfail-proof.
- If you wish to use a warm restart (restart)/complete restart for the CPU 41x-2 PCI.
- For retentive memory of memory markers, timers, counters, time of day and system data, as well as data in variable data blocks.

A lithium battery (type AA, 3.6 V cell voltage) is used for the standby power supply to the CPU 41x-2 PCI.



Warning

Risk of injury and material damage, risk of hazardous substances escaping.

If handled wrongly, a lithium battery can explode; improper disposal of old lithium batteries may result in hazardous substances escaping. It is therefore imperative that you comply with the following information:

- Do not throw new or spent batteries into the fire and do not solder on the cell body (maximum temperature of 100 °C); do not recharge as there is a risk of explosion.
 - Do not open the battery and replace it only with an identical type. Obtain your replacement only from Siemens. This will ensure that you are in possession of a short-circuit-proof type.
 - To the extent possible, return old batteries to the battery manufacturer or forward them to a recycler, or dispose of them as hazardous waste.
-

Removing the passivation layer

When lithium batteries (lithium/thionyl chloride) are used as backup batteries, a passivation layer may form after very long periods of storage and cast doubt on the immediate ability of the battery to operate. One of the consequences is an error message after the PS extension board is turned off.

The CPU 41x-2 PCI is capable of removing the passivation layer on the lithium battery by means of defined battery loading. This process may last several minutes. When the passivation layer has been destroyed and the lithium battery has reached its rated voltage, the error message on the control panel has to be acknowledged by choosing the option **CPU > FMR** from the menu.

Since the time the lithium battery has spent in storage is generally not known, we recommend that you perform the following steps:

1. Connect the backup battery to the "BATT." socket on the slot plate of the PS extension board.
2. If a battery error message is displayed on the control panel ("BATF" LED), acknowledge it by choosing the option **CPU > FMR** from the menu.

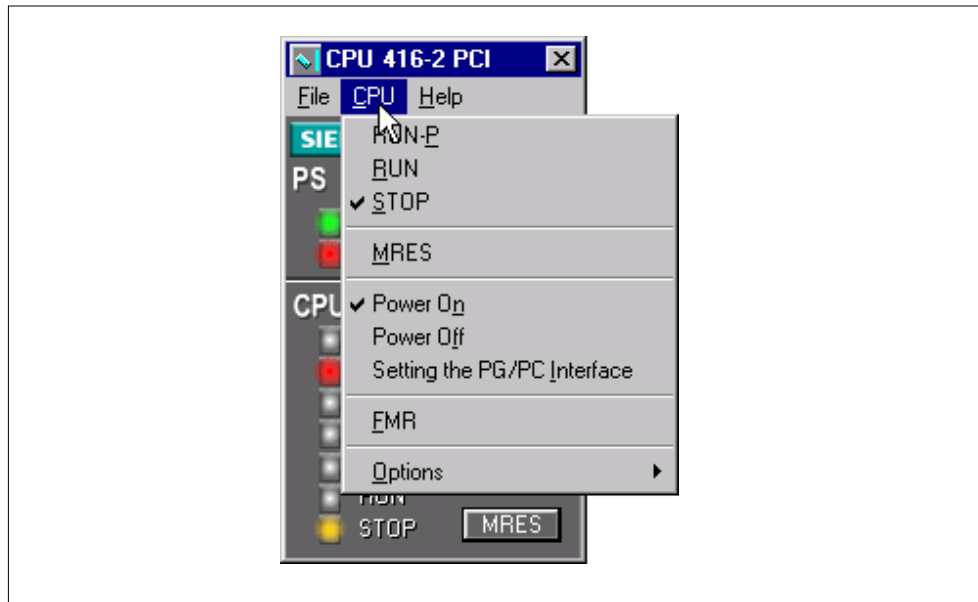

Figure 4-1 CPU > FMR Menu Option

3. If the battery error cannot be acknowledged, wait and try again after a few minutes.
4. If the battery error still cannot be acknowledged, remove the battery and short-circuit the battery for not longer than 1 to 3 seconds.
5. Insert the battery again and make another attempt to acknowledge the battery error message by choosing the option **CPU > FMR** from the menu.

If the battery error message is no longer displayed, the battery is capable of operation.

If the battery error message continues to be displayed, the battery is empty.

Note

If the power supply for the CPU 41x-2 PCI fails while you are changing the battery, the user program and the data you wished to retain will be lost.

Remedy: connect the PS extension board additionally to an external 24 V DC source.

4.5 Reset Button: Resetting the Module

The reset pushbutton (operate for not less than 1 second) on the slot plate of the CPU 41x-2 PCI can be used to reset the CPU 41x-2 PCI without the control panel. For safety reasons, the CPU 41x-2 PCI then goes automatically to STOP.

Following that, you can change to RUN only by means of the mode switch on the control panel.

CPU 412-2 PCI and CPU 416-2 PCI Control Panel

5

In this chapter

| Section | Contents | Page |
|---------|--|------|
| 5.1 | Overview | 5-2 |
| 5.2 | Controls and Display Elements of CPU 41x-2 PCI | 5-3 |
| 5.3 | Status and Error Indications | 5-4 |
| 5.4 | Operating Mode Controls | 5-8 |
| 5.5 | Loading and Saving the STEP 7 User Program | 5-11 |
| 5.6 | CPU 41x-2 PCI Controls on the Menu Bar | 5-16 |

5.1 Overview

The controls and display elements of the CPU 41x-2 PCI are shown symbolically on the PC display as a control panel. The functions and names of the controls and display elements are similar to the switches and LEDs on the front panel of the S7-400 CPUs.

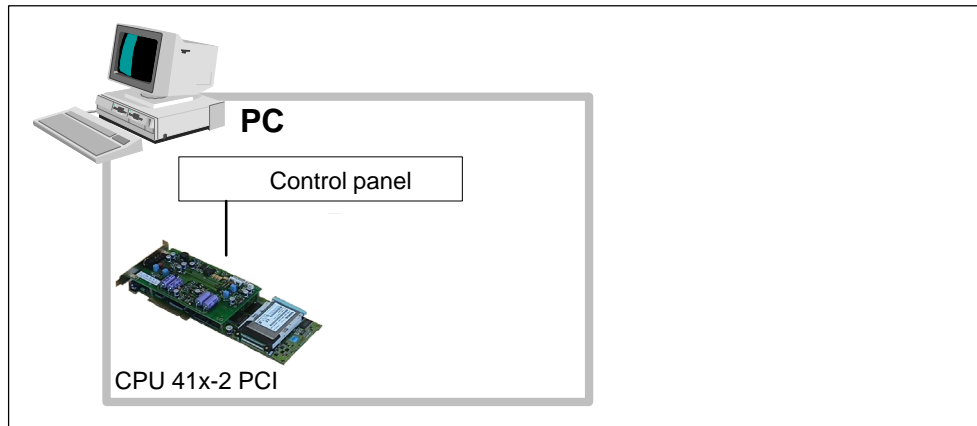

Figure 5-1 CPU 41x-2 PCI Control Panel

Requirements

For the CPU 41x-2 PCI control panel to operate, the CPU 41x-2 PCI must be installed.

5.2 Controls and Display Elements of CPU 41x-2 PCI

Introduction

The controls and display elements of the CPU 412-2 PCI or the CPU 416-2 PCI are symbolically shown on the PC display as a control panel. Open the control panel for the CPU 412-2 PCI or CPU 416-2 PCI by choosing from the task bar:

Start > Simatic > PC Based Control > CPU 412-2 PCI
Start > Simatic > PC Based Control > CPU 416-2 PCI

Controls and Display Elements of CPU 41x-2 PCI

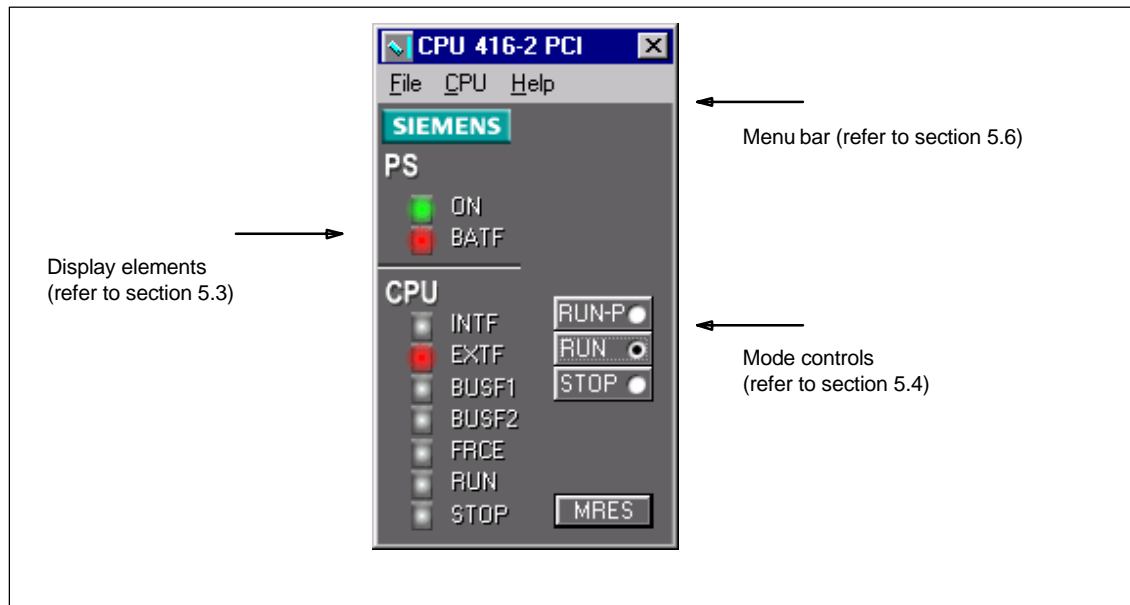

Figure 5-2 Controls and Display Elements of CPU 41x-2 PCI on the Control Panel

5.3 Status and Error Indications

LED displays on the control panel

Table 5-1 provides an overview of the LED display elements available on the CPU 41x-2 PCI.

Table 5-1 LED Displays on the Control Panel

| LEDs | Color | Description |
|--------|--------|--|
| ON | Green | Indicates the CPU 41x-2 PCI is ready |
| BATTF | Red | Battery fault, battery empty |
| INTF | Red | Internal fault |
| EXTF | Red | External fault |
| BUSF 1 | Red | Bus error at the MPI/PROFIBUS-DP interface |
| BUSF 2 | Red | Bus error at the MPI/PROFIBUS-DP interface |
| FRCE | Yellow | Force job active |
| RUN | Green | RUN mode |
| STOP | Yellow | STOP mode |

In addition, the slot plate of the CPU 41x-2 PCI contains the LEDs R (RUN), S (STOP), SF (INTF, EXTF) and BF (BUSF1, BUSF2).

Note

You will find additional information about the significance of the LEDs BUSF 1 and BUSF 2 when operating as a DP master/DP slave in Section 6.3 and in Section 6.5.1.

Status displays

LED displays RUN and STOP on the control panel inform you which CPU mode is currently active.

Table 5-2 Status Displays

| LEDs | | Description |
|------|------|--|
| RUN | STOP | |
| ☒ | ⌋ | CPU is in RUN mode. |
| ⌋ | ☒ | CPU is in STOP mode. The user program is not run. Complete restart or restart is possible. If STOP mode was initiated by an error, the fault indication (INTF or EXTF) is also set. |
| ⌋ | ⌋ | CPU is in DEFECT mode. LED displays RUN, STOP, FRCE, BUSF1, BUSF2, EXTF and INTF flash. |
| ⌋ | ☒ | HALT mode was initiated by the test function (breakpoint). |
| ⌋ | ☒ | A restart/complete restart was triggered. Depending on the length of the called OB, it may take a minute or even longer before the restart/complete restart is performed. If the CPU does not then go to RUN, there might be an error in the configuration, for example. |
| ⌋ | ⌋ | The CPU requests a memory reset. |
| ⌋ | ⌋ | Memory reset in progress. |

☒ = LED display on; ⌋ = LED display off;

⌋

⌋ = LED display flashes slowly at 0.5 Hz

Error displays and special events

The three LED displays, INTF, EXTF and FRCE, inform you about errors and special events in the course of the user program.

Table 5-3 Error Displays and Special Events

| LEDs | | | Description |
|------|------|------|--|
| INTF | EXTF | FRCE | |
| ☒ | ⌋ | ⌋ | An internal error has been detected (programming or parameterization error). |
| ⌋ | ☒ | ⌋ | An external error has been detected (in other words, an error whose cause is not to be found on the CPU module). |
| ⌋ | ⌋ | ☒ | A Force job is active. |

☒ = LED display on; ⌋

Monitoring and error messages

The CPU hardware and the operating system incorporate monitoring functions which guarantee proper working and behavior complying with a predefined pattern in the event of an error. With a number of errors, it is possible that the user program might react.

The following table provides an overview of potential errors, their causes and the ways in which the CPU reacts.

Furthermore, test and information functions, with which you can open STEP 7, are available to you in every CPU.

| Error Type | Error Cause | Reaction by Operating System | LEDs |
|--|---|---|------|
| Clock failure | Monitoring of the processor clock failure System comes to a standstill. | Disabling of the outputs by issuing an "OD" (Output Disable) signal | – |
| Acknowledgement error | Failure of a module (SM, FM, CP) | "EXTF" LED display lights until the error is cleared. With SMs: <ul style="list-style-type: none"> • OB 122 called • Entry in diagnostic buffer • With input modules: entering of "zero" as the date in the ACCU or the process image With other modules: <ul style="list-style-type: none"> • OB 122 called | EXTF |
| Timer error | <ul style="list-style-type: none"> • The run time of the user program (OB1 and all interrupts and error OBs) exceeds the specified maximum scan cycle time. • OB request error • Overflow of the startup information buffer • Time-of-day error interrupt | "INTF" LED display lights until the error is acknowledged. OB 80 called If OB not loaded: the CPU goes to STOP. | INTF |
| Power supply unit fault (not a power failure) | <ul style="list-style-type: none"> • Backup battery is empty • There is no battery backup voltage | OB 81 called If OB not loaded: the CPU continues to run. | EXTF |
| Diagnostic interrupt | An I/O module with interrupt capability reports a diagnostic interrupt. | OB 82 called If OB not loaded: the CPU goes to STOP. | EXTF |
| Plug and remove interrupt | A SM removed or plugged in, or wrong module type plugged in. | OB 83 called If OB not loaded: the CPU goes to STOP. | EXTF |
| Interface error at MPI/DP/AS-internal communications (C bus) | A CPU interface has detected a serious error – for example, a short-circuit on the bus, duplicate addressing on the network, or a serious protocol error. | Entry in the diagnostic buffer OB 84 is no longer processed, in contrast to the CPU 416-2 DP ISA/CPU 416-2 DP IS A Lite. If OB 84 is not loaded, the CPU goes to STOP. | EXTF |

| Error Type | Error Cause | Reaction by Operating System | LEDs |
|----------------------|---|--|------|
| Priority class error | <ul style="list-style-type: none"> Priority class called, but relevant OB missing. With SFB call: instance DB missing or fault. Error upon updating the process image. | OB 85 called If OB not loaded: the CPU goes to STOP. | INTF |
| | | | EXTF |
| Failure of a station | <ul style="list-style-type: none"> Failure of a DP line Failure of a coupling line or interrupted line | OB 86 called If OB not loaded: the CPU goes to STOP. | EXTF |
| Communication error | <ul style="list-style-type: none"> Status information cannot be entered in DB. Incorrect message ID Message length error Illegal global ID number DB access error | OB 87 called If OB not loaded: the CPU goes to STOP. | INTF |
| Programming error | Error in machine code or in user program: <ul style="list-style-type: none"> BCD conversion error Range length error Range error Alignment error Write error Timer number error Counter number error Block number error Block not loaded | OB 121 called If OB not loaded: the CPU goes to STOP. | INTF |
| Access error | The SM assigned to the addressed address is not plugged in or is defective. | OB 122 called If OB not loaded: the CPU goes to STOP. | EXTF |
| MC7 code error | Error in compiled user program – for example, invalid OP code or jump to past the block end. | The CPU goes to STOP. | INTF |

Reading out the cause of error (diagnostic buffer)

For troubleshooting, you can read out the exact cause of error in STEP 7 (**PLC > Module Information**) from the diagnostic buffer.

5.4 Operating Mode Controls

In this chapter

| Section | Contents | Page |
|---------|----------------------------|------|
| 5.4.1 | Selecting the Startup Type | 5-9 |
| 5.4.2 | Protection Levels | 5-10 |

You can use the operating mode controls to change the CPU to RUN/RUN-P mode or to STOP mode, or to reset the CPU. STEP 7 features other options for changing the operating mode.

Table 5-4 explains the operation of the operating mode controls. If an error occurs, or if any obstacles are encountered during startup, the CPU will go to or remain at STOP, irrespective of operation.

Table 5-4 Operation of the Controls

| Operation | Description |
|-----------|--|
| RUN-P | <p>If no obstacle is encountered during startup and if no error has occurred and the CPU succeeded in going to RUN, the CPU processes the user program or idles. Accesses to the I/O are possible.</p> <p>Programs can:</p> <ul style="list-style-type: none"> • Be read from the CPU using a programming device (CPU ⇒ PG), • Transferred to the CPU (PG ⇒ CPU). |
| RUN | <p>If no obstacle is encountered during startup and if no error has occurred and the CPU succeeded in going to RUN, the CPU processes the user program or idles. Accesses to the I/O are possible.</p> <p>Programs in the CPU can be read out with the programming device (CPU ⇒ PG).</p> <p>The program in the CPU cannot be modified at switch setting RUN. (Refer to STEP 7) The protection level can be bypassed by a password set in STEP 7/Configure Hardware – in other words, when this password is known, the program can be modified at switch setting RUN.</p> |
| STOP | <p>The CPU does not execute the user program. The signal modules are inhibited.</p> <p>Programs can:</p> <ul style="list-style-type: none"> • Be read from the CPU using a programming device (CPU ⇒ PG), • Transferred to the CPU (PG ⇒ CPU). |
| MRES | <p>The CPU goes to STOP mode. In this instance, the following tasks are performed:</p> <ul style="list-style-type: none"> • The CPU deletes the entire user program from its load and work memories. • If a flash card is inserted, the program stored on the flash card will be initiated following a memory reset. • The CPU resets the memory areas (I, O, M, T, and C). <p>After the memory has been reset, the diagnostic buffer remains unchanged, as does the MPI address.</p> |

5.4.1 Selecting the Startup Type

You use startup type selection to set whether the CPU performs a warm restart (restart) or a cold restart when the operating mode of the CPU goes from STOP to RUN.

Clicking the operating mode controls with the left mouse button performs a warm restart (restart) should the mode change from STOP to RUN.

Clicking the right mouse button opens a dialog box, if the operating mode changes from STOP to RUN, in which you can select the startup type (refer to Figure 5-3).

Requirements

To be able to use the options of warm restart (restart) and complete restart following POWER UP of the PC, you must have

- connected the PS extension board to the CPU 41x-2 PCI.
- connected the backup battery to the PS extension board.



Figure 5-3 Selecting the Startup Type

Table 5-5 Startup Types for CPU 41x-2 PCI

| Warm Restart (Restart) | Complete Restart | Cold restart |
|---|--|--|
| <p>With a warm restart (restart), the user program is restarted from the beginning. The retentive data and the contents of the data blocks are not lost.</p> <p>The CPU has to be battery backed so that a memory reset is not performed following POWER UP and before the restart.</p> | <p>In the case of a complete restart, the user program continues at the point it was interrupted.</p> <p>For the Complete Restart function following POWER UP (automatic complete restart),</p> <ul style="list-style-type: none"> • the CPU has to be battery backed • complete restart has to be enabled in STEP 7, in addition to the setting on the control panel. | <p>With a cold restart, the user program is restarted from the beginning. All data, including the retentive data, are deleted.</p> |
| <p>To perform a warm restart (restart), the operating system calls the restart OB (OB100).</p> | <p>To perform a complete restart, the operating system calls the complete restart OB (OB 101).</p> | <p>To perform a cold restart, the operating system calls OB102.</p> |

5.4.2 Protection Levels

With the CPU 41x-2 PCI, a protection level can be declared, by means of which the programs in the CPU can be protected from access by unauthorized persons. With a protection level, you set the programming device functions which a user can perform without having special authorization (password) on the CPU concerned. All programming device functions are authorized as a result of using the password.

Setting the protection levels

You can set the protection levels (1 to 3) for a CPU in STEP 7/Configure Hardware.

The protection level set in STEP 7/Configure Hardware can be removed by manually resetting the memory with the controls if you have inserted a RAM card. The protection level you selected for the user program remains effective on the flash card.

You can also set protection levels 1 and 2 using the controls. Table 5-6 shows the protection levels for the CPU 41x-2 PCI.

Table 5-6 CPU 41x-2 PCI Protection Levels

| Protection Level | Function | Operating Mode Selector |
|------------------|--|-------------------------|
| 1 | <ul style="list-style-type: none"> All programming device functions are allowed (default setting). | RUN-P / STOP |
| 2 | <ul style="list-style-type: none"> All functions for process manipulation, process monitoring and process communications are allowed. All information functions are allowed. Downloading of objects from the CPU onto the programming device is allowed – in other words, read only programming device functions are allowed. | RUN |
| 3 | <ul style="list-style-type: none"> Neither read nor write programming device functions are allowed. | – |

If the protection levels set with the mode switch and STEP 7 are not identical, the higher protection level (3 before 2, 2 before 1) applies.

5.5 Loading and Saving the STEP 7 User Program

In this chapter

| Section | Contents | Page |
|---------|--|------|
| 5.5.1 | A Few Explanations before Proceeding | 5-11 |
| 5.5.2 | Saving and Loading the STEP 7 User Program | 5-12 |

5.5.1 A Few Explanations before Proceeding

Load and work memories

When you load the STEP 7 user program into the CPU 41x-2 PCI, the logic and data blocks are loaded into the load and work memories of the CPU 41x-2 PCI.

To ensure rapid processing of the STEP 7 user program, only those parts of the blocks that are important for program scanning are loaded into the **work memory**. Block sections that are not necessary for running the program (for example, block headers) remain in the **load memory**.

The following figure illustrates loading of the program into the CPU memory:

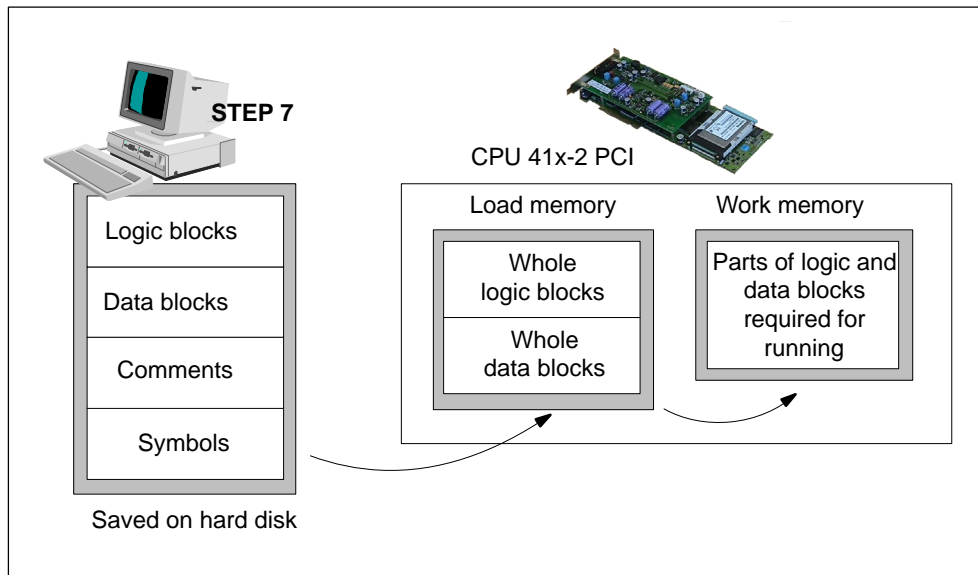

Figure 5-4 Loading the STEP 7 User Program into the Memory of CPU 41x-2 PCI

Structure of the load memory

You can expand the load memory by means of a memory card. Depending on whether you select a RAM card or a FLASH card for expanding the load memory, the response during loading, reloading and memory reset may differ. You will find further information on this topic in Chapter 10.

Definition

A **memory card file** is equivalent to the contents of the memory card. The memory card file contains the STEP 7 user program and the hardware configuration (SDBs).

If you create the memory card file with the help of STEP 7, the DBs will contain the initial values.

If you create the memory card file using the control panel by choosing **File → Archive by CPU**, the DBs will contain the current values.

5.5.2 Saving and Loading the STEP 7 User Program

The memory card can only be withdrawn and plugged in when the PC is open. You have the option, however, of reading STEP 7 user programs from the CPU 41x-2 PCI or storing them on the CPU 41x-2 PCI without your having to remove and plug in the memory card:

- With the **File > Archive** function, you can load the STEP 7 user program and the hardware configuration from the load memory of the CPU 41x-2 PCI onto the PC (memory card file).
- With the **File > Restore** function, you can load a STEP 7 user program and the hardware configuration from the PC (memory card file) into the load memory of the CPU 41x-2 PCI.
- By means of the **CPU > Options > Autoload** function, the PC fetches a memory card file you preselected after a POWER UP and loads this file into the load memory of the CPU 41x-2 PCI. The STEP 7 user program then runs on the CPU 41x-2 PCI.

Archiving

With the **File > Archive** function, you can save on the PC the STEP 7 user program and the hardware configuration residing on the CPU 41x-2 PCI. The control panel reads out the load memory of the CPU 41x-2 PCI and stores this file with the extension “*.wld” on the hard disk.

This file (memory card file) contains the STEP 7 user program and the current hardware configuration (DBs).

This function is also supported in SIMATIC Manager with **File > Memory Card File**.

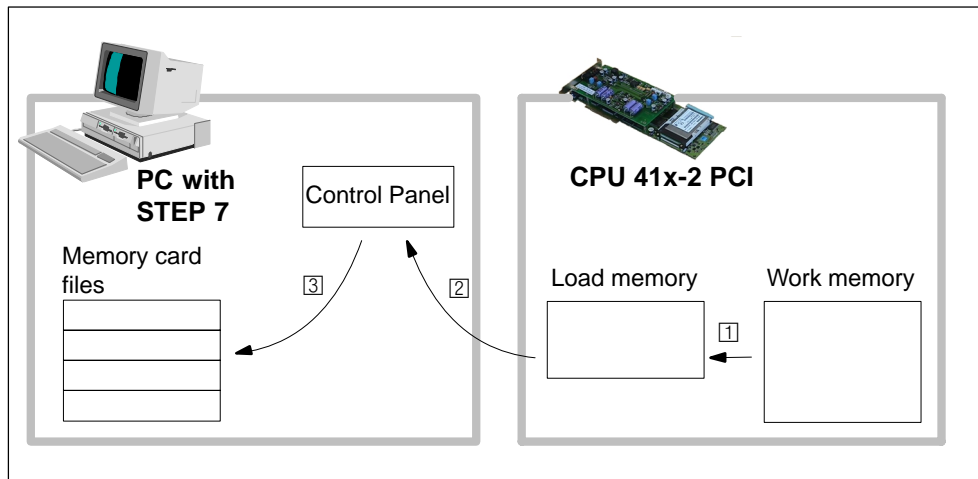

Figure 5-5 Archiving

Restore

With the **File > Restore** function, you can load a STEP 7 user program and the hardware configuration from the PC into the load memory of the CPU 41x-2 PCI.

First, select a memory card file having an extension “*.wld” and load it into the load memory of the CPU 41x-2 PCI.

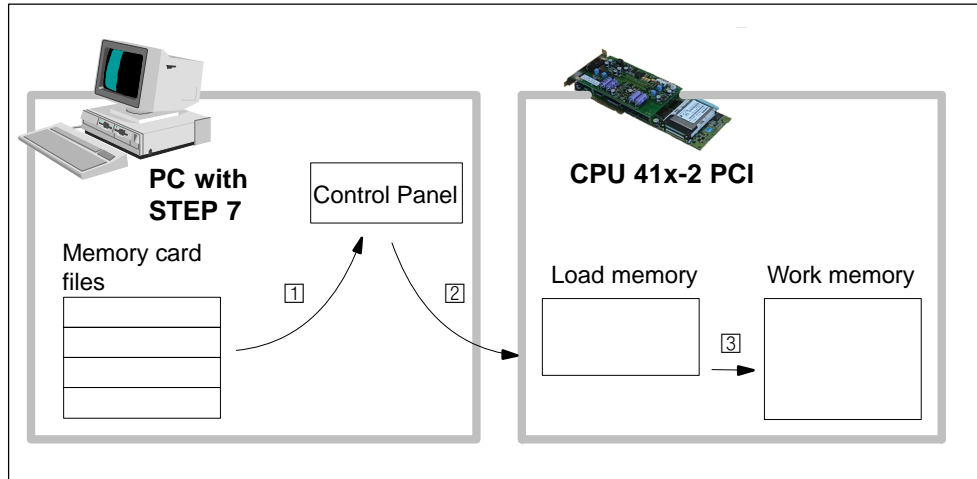

Figure 5-6 Restoring

Autoload

Application: using the “Autoload” function after a POWER UP of the PC, you can download a STEP 7 user program and the hardware configuration to the CPU 41x-2 PCI. This makes sense in the following cases in particular:

- during the commissioning phase
- in unbuffered operation of the CPU 41x-2 PCI

Requirements: to be able to use the “Autoload” function,

- no FLASH card must be plugged into the CPU 41x-2 PCI, or the CPU 41x-2 PCI must be operated without a backup battery.
- the access point of the application has to be set to “PC internal” using **CPU > Set PG/PC Interface**.

The figure below illustrates the basic process during the “Autoload” function:

1. With the “Autoload” function, select a memory card file and the setting of the mode switch.
2. Following POWER DOWN/POWER UP of the PC, the PC selects the memory card file that you had previously selected, and
3. writes it to the load memory of the CPU 41x-2 PCI.
4. The CPU 41x-2 PCI then starts the loaded memory card file and then goes to the mode that is stored in the memory card file (STOP, RUN, RUN-P).

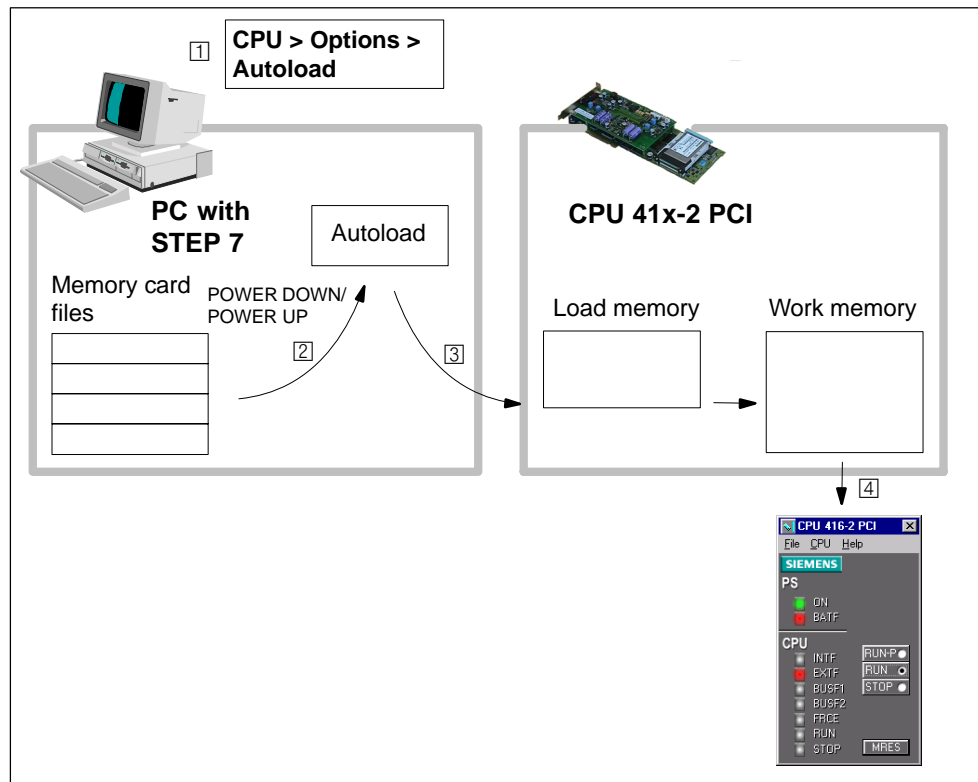

Figure 5-7 Autoload

5.6 CPU 41x-2 PCI Controls on the Menu Bar

In this chapter

The menu bar consists of three menus:

- File menu
- CPU menu
- Help menu

| Section | Contents | Page |
|---------|-----------------------|------|
| 5.6.1 | "File" Menu | 5-17 |
| 5.6.2 | "CPU" Menu | 5-18 |
| 5.6.3 | "Customize" Submenu | 5-19 |
| 5.6.4 | "Safety" Submenu | 5-21 |
| 5.6.5 | "Connect CPU" submenu | 5-23 |
| 5.6.6 | "Help" Menu | 5-23 |

5.6.1 "File" Menu

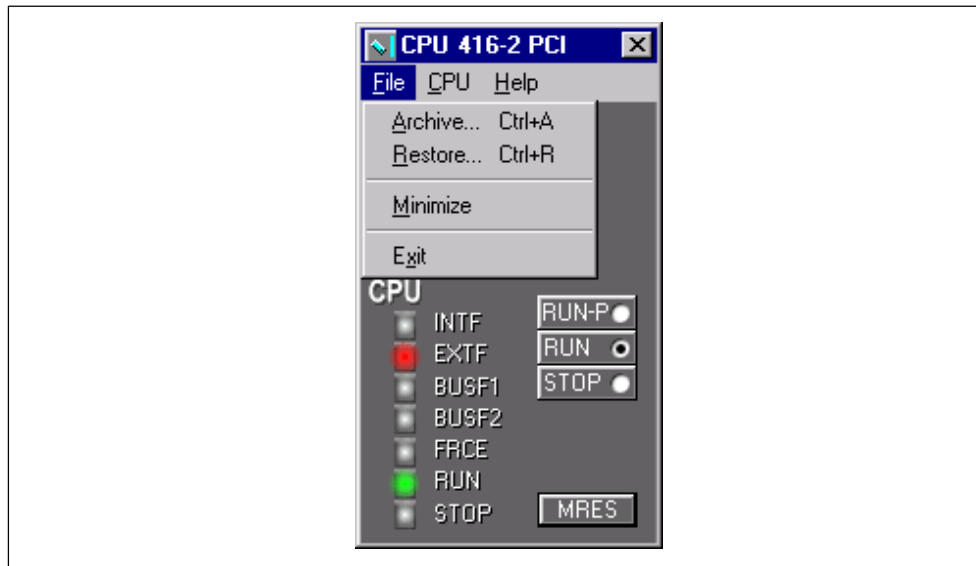

Figure 5-8 "File" Menu

| Menu Command | Description |
|--------------|---|
| Archive | Creating a memory card file (archive file): you create the memory card file. A dialog box then allows you to save the memory card file under a specific name. In this way you can create several memory card files (refer to section 5.5). The memory card file contains the STEP 7 user program and the hardware configuration (SDBs). |
| Restore | Restore a memory card file: When restoring the memory card file, you load the STEP 7 user program and the hardware configuration (SDBs) (refer also to section 5.5). |
| Minimize | By clicking the "Minimize" button, you reduce the control panel to the Windows taskbar. |
| Exit | Clicking the "Exit" button closes the control panel. |

Note

After you exit from the control panel, all the settings and states on the CPU 41x-2 PCI remain active.

5.6.2 "CPU" Menu

On this menu you will find special operations for the CPU 41x-2 PCI.

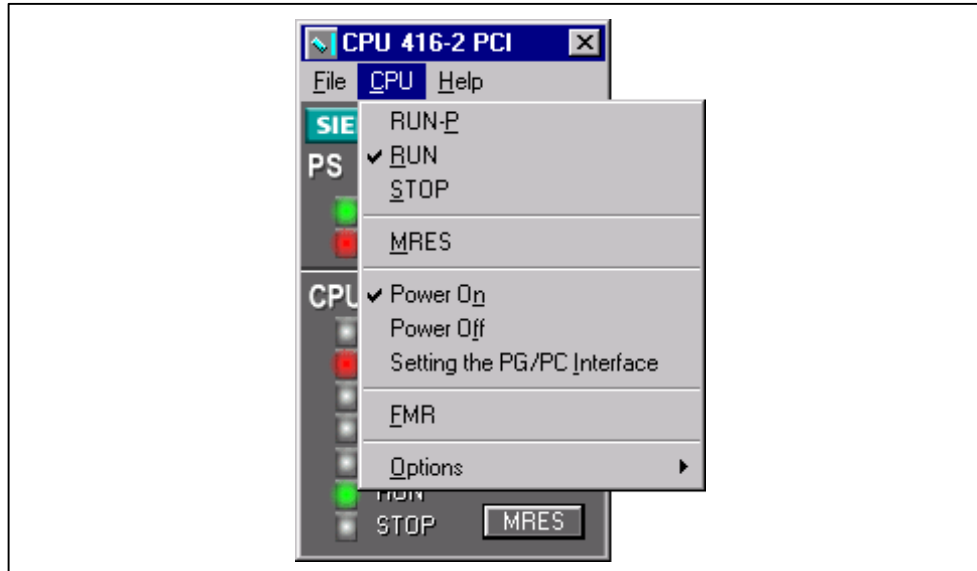

Figure 5-9 "CPU" Menu

| Menu Command | Description |
|--------------|--|
| RUN-P | Clicking the "RUN-P" button sends the CPU 41x-2 PCI to RUN mode. Program changes are possible using the programming device. If you wish to change from STOP mode to this operating mode, you have the option of selecting the startup type (refer to section 5.4.1). |
| RUN | Clicking the "RUN" button sends the CPU 41x-2 PCI to RUN mode. Program changes are not possible on the programming device. If you wish to change from STOP mode to this operating mode, you have the option of selecting the startup type (refer to section 5.4.1). |
| STOP | Clicking the "STOP" button sends the CPU 41x-2 PCI to STOP mode. |
| MRES | Clicking the "MRES" button resets the CPU memory. |
| Power On | Clicking the "Power On" button turns on the CPU 41x-2 PCI. The CPU 41x-2 PCI then behaves like a normal CPU module: it performs power up initializations and goes to STOP or RUN mode, depending on what has already happened and on the current switch setting. Note: you activate the CPU 41x-2 PCI functions with this button. The CPU 41x-2 PCI is already being supplied with working voltage by the power supply unit on the PC and possibly also by the PS extension board. |
| Power Off | Clicking the "Power Off" button turns off the CPU 41x-2 PCI. The CPU 41x-2 PCI behaves like a normal CPU module: it saves its current states in order to be able to perform a complete restart, if necessary (when operating with a PS extension board). Note: you deactivate the CPU 41x-2 PCI functions with this button. The CPU 41x-2 PCI continues to be supplied with working voltage by the power supply unit on the PC and possibly also by the PS extension board. |

| Menu Command | Description |
|-----------------------------|---|
| Setting the PG/PC Interface | When you operate this button, you call the "Set PG/PC Interface" program, which you can use, say, to set the access of STEP 7 (PC internal when accessing within the PC) or to set the network access for time synchronization. |
| FMR | Clicking the "FMR" button acknowledges the battery fault (refer also to section 4.4). |
| Options | Selecting the "Options" button opens another submenu with the menu options <ul style="list-style-type: none"> • Customize • Security • Connect CPU |

5.6.3 "Customize" Submenu

Clicking the "Customize" button opens the Customize dialog box with three tabs: General, Language and Autoload.

General

On this tab you can specify whether the control panel should always be displayed on top.

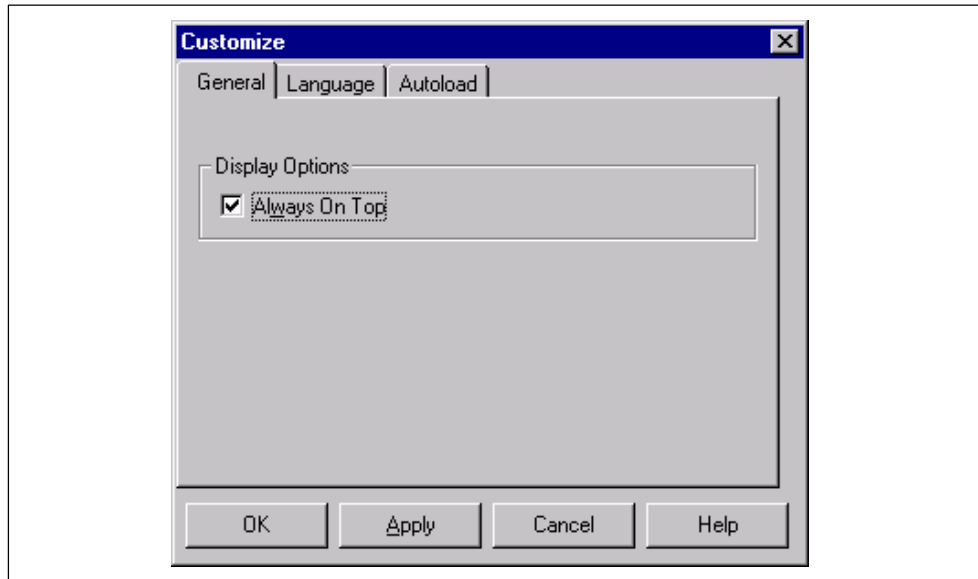

Figure 5-10 "General" Tab

Language

On this tab you select the language in which you would like to work. The language is always changed collectively for the router, time synchronization, SIMATIC Computing and Tool Manager applications. The new language does not take effect until the application has been restarted.

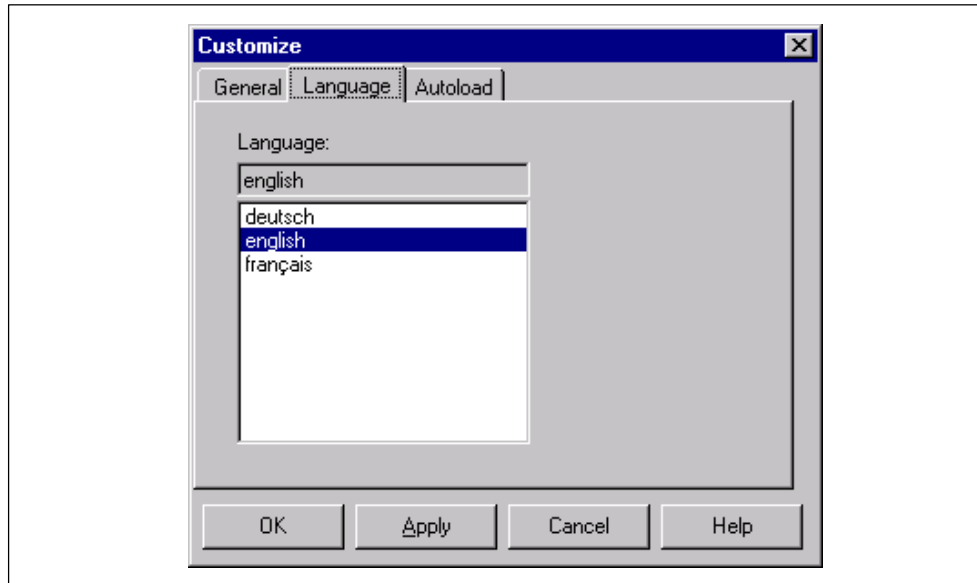

Figure 5-11 "Language" Tab

Autoload

WinAC Slot 41x features an autoload function, which defines how WinAC Slot 41x reacts to POWER DOWN/POWER UP of the PC (refer to section 5.5). You can

- load the STEP 7 user program automatically and
- select the operating mode of the CPU 41x-2 PCI after loading the STEP 7 user program (STOP, RUN, RUN-P).

For the Autoload function, the access point of the application must be set "S7 Online → PC Internal" using **CPU > Set PG/PC Interface**.

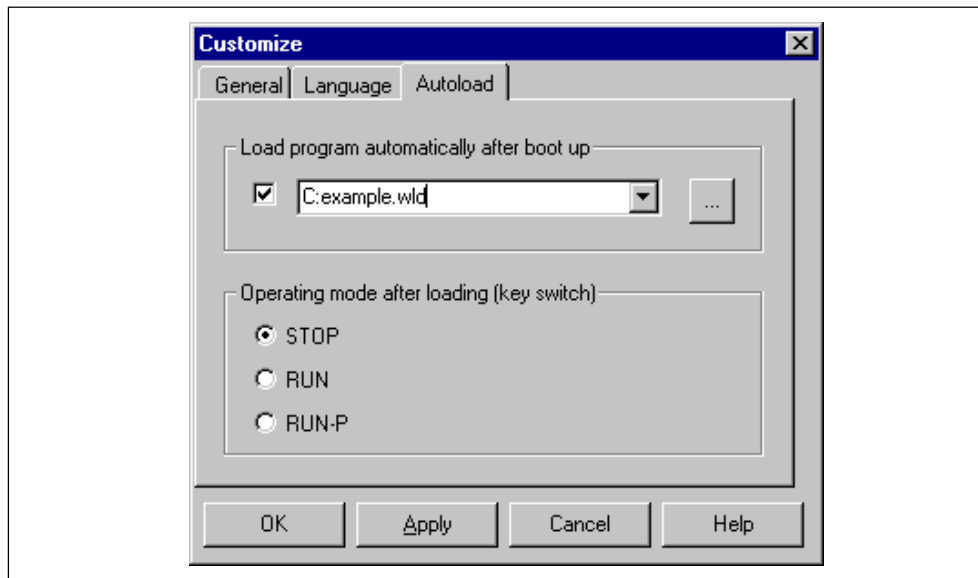

Figure 5-12 "Autoload" Tab

5.6.4 "Safety" Submenu

You must always enter your password in the "Access Rights" dialog box to open the "Access Protection" dialog box. Enter your password here. If a password has not yet been allocated, you can click "OK" immediately.

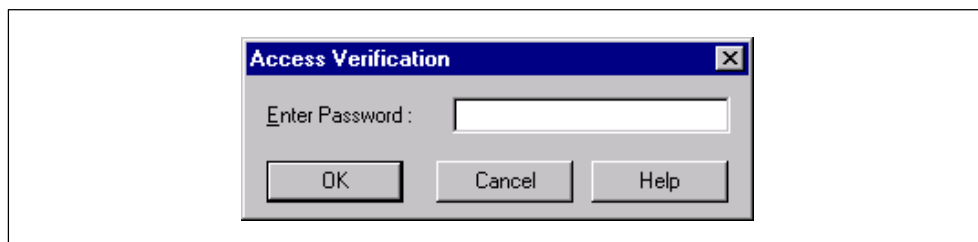

Figure 5-13 "Access Rights" Dialog Box

If the password has been entered correctly, the "Access Protection" dialog box

opens. In this dialog box, you have the option of authorizing different safety levels for operation of the CPU 41x-2 PCI Controller.

- Password

Every manual change made on the CPU control panel (for example, change of operating mode) can be made only after the password has been entered.

- Confirmation

Every manual change on the control panel (for example, change of operating mode) has to be confirmed by acknowledging a message.

- Without

Neither confirmation nor a password is necessary for changing the operating mode of the CPU.

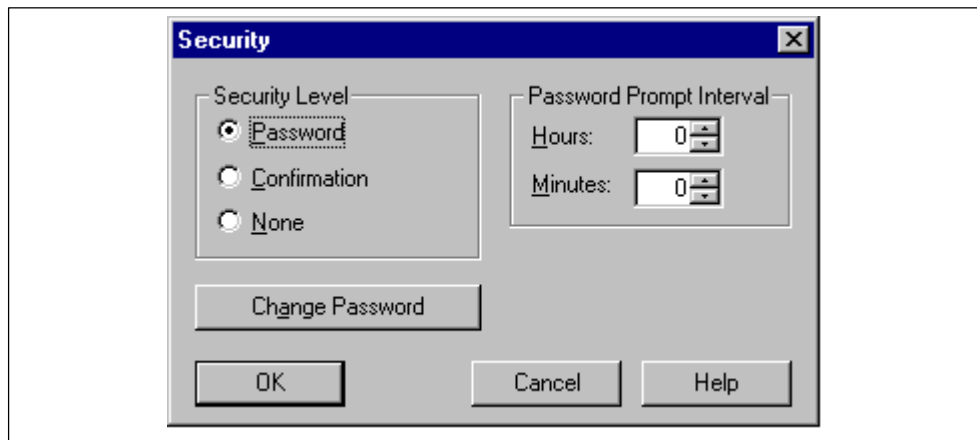

Figure 5-14 "Access Verification" Dialog Box

At "Interval for Password Check", you can set the period that has to elapse before a password entry request is made not more than 23 hours and 59 minutes. Once the password has been entered, the system waits until the set period has elapsed before prompting for the password again.

You can change the current password by clicking "Change Password".

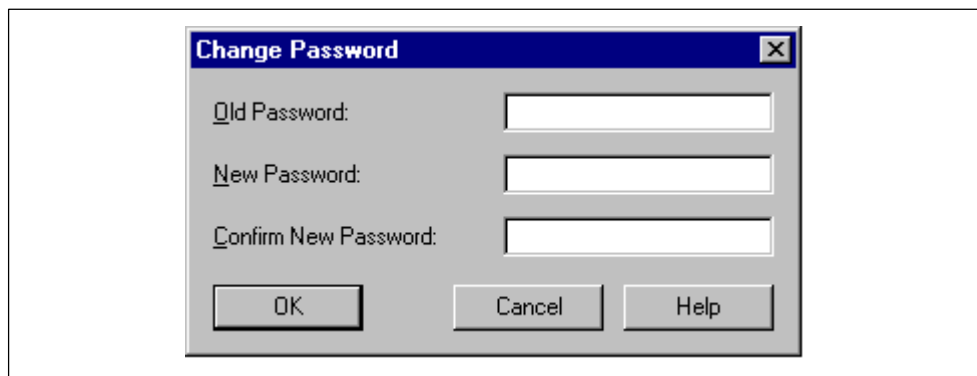

Figure 5-15 "Change Password" Dialog Box

5.6.5 “Connect CPU” Submenu

If you modify the configuration within the PC (by, say, assigning a name to a CP), you must then reconnect the CPU 41x-2 PCI to communications within the PC by means of the command **CPU > Options > Connect CPU**.

Note

If you modify the configuration of the CPU 41x-2 PCI in the component configurator (by, say, assigning a new name), you must quit the control panel and open it again.

5.6.6 ”Help” Menu

On this menu you will find the online Help, and information about the control panel and general handling of the CPU 41x-2 PCI.

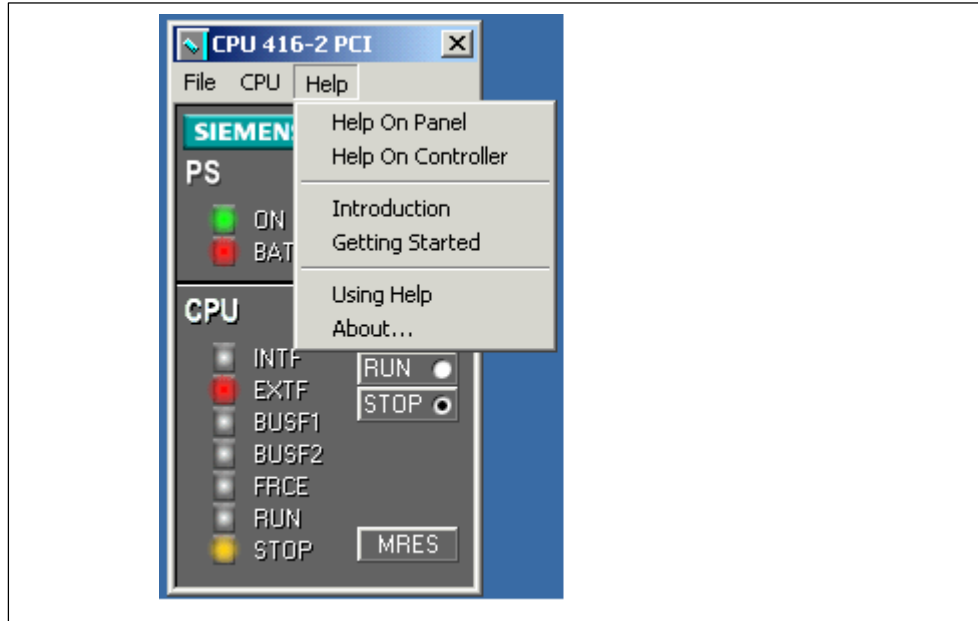

Figure 5-16 ”Help” Menu

| Menu Command | Description |
|--------------------|--|
| Help on Panel | The “Help on Panel” menu command provides information about the control panel. |
| Help on Controller | The “Help on Controller” menu command provides information about the controller. |

| Menu Command | Description |
|---------------------|---|
| Introduction | Clicking the "Introduction" button provides you with a concise overview of the use, important features and functional scope of the CPU 41x-2 PCI. |
| Getting Started | Clicking the "Getting Started" button shows you what you have to do in order to achieve initial success. |
| Using Help | Clicking the "Using Help" button provides you with help on using Help. |
| About... | Clicking the "About..." button provides you with information about the current version of the CPU 41x-2 PCI. |

CPU 41x-2 PCI as DP Master/DP Slave and Direct Data Exchange

6

Introduction

This chapter introduces to you the characteristics and technical specifications for CPUs 41x-2 PCI, which you will require when you use the CPU as a DP master or as a DP slave or for a direct exchange of data.

Declaration: since the DP master/DP slave response is the same for all CPUs, the CPUs will be referred to as CPU 41x-2 PCI in the following.

In this chapter

| Section | Contents | Page |
|---------|---|------|
| 6.1 | DP Address Area of CPUs 41x-2 PCI | 6-2 |
| 6.2 | CPU 41x-2 PCI as DP Master | 6-3 |
| 6.3 | Diagnostics of CPU 41x-2 PCI as DP Master | 6-6 |
| 6.4 | CPU 41x-2 PCI as DP Slave | 6-11 |
| 6.5 | Diagnostics of CPU 41x-2 PCI as DP Slave | 6-16 |
| 6.6 | Direct Data Exchange | 6-31 |
| 6.7 | Diagnostics During Direct Data Exchange | 6-32 |

Further reading

Descriptions and information about configuration, configuring a PROFIBUS subnet and diagnostics the PROFIBUS subnet will be found in the *STEP 7* online help.

6.1 DP Address Area of CPUs 41x-2 PCI

Address areas of CPUs 41x-2 PCI

Table 6-1 CPUs 41x-2 PCI (MPI/DP Interface as PROFIBUS-DP)

| Address Area | CPU 412-2 PCI | CPU 416-2 PCI |
|--|---------------|---------------|
| MPI as PROFIBUS-DP, inputs and outputs in each case (byte) | 2048 | 2048 |
| DP interface as PROFIBUS-DP, inputs and outputs in each case (byte) | 4096 | 8192 |
| Of which in the process image inputs and outputs in each case adjustable up to x bytes | 4096 | 16384 |

DP diagnostics addresses each require in the address area 1 byte for the DP master and each DP slave for the inputs. At these addresses, the DP standard diagnostics for each node can be called, for example, (LADDR parameter of SFC 13). You set the DP diagnostics addresses when you are configuring. If you do not want to set DP diagnostics addresses, *STEP 7* assigns the addresses from the highest byte address downwards as DP diagnostics addresses.

6.2 CPU 41x-2 PCI as DP Master

Introduction

In this chapter we describe the characteristics and technical specifications of the CPU when you are operating it as a DP master.

You will find the characteristics and technical specifications of CPUs 41x-2 PCI in Section 8.2 and 8.3.

Requirements

Do you want the MPI/DP interface to be a DP interface? If so, you must configure the interface as the DP interface.

You have to configure the CPU as the DP master before starting to commission. This means that you have to perform the following in *STEP 7*

- Configure the CPU as the DP master
- Assign a PROFIBUS address
- Assign a master diagnostics address
- Link the DP slaves to the DP master system.

Is one DP slave a CPU 41x-2 PCI?

If so, you will find this DP slave as a "preconfigured station" in the PROFIBUS-DP catalog. You assign a slave diagnostics address to the DP slave CPU. You must connect the DP master to the DP slave CPU and define the address areas for data exchange to the DP slave CPU.

Status/Force, programming over PROFIBUS

As an alternative to the MPI, you can program the CPU through the PROFIBUS-DP interface, or you can execute the PG functions Status and Force.

Note

The use of programming or Status and Force through the PROFIBUS-DP interface increases the DP scan cycle time.

Equidistance

In STEP 7 V 5.x or higher, you can parameterize bus scan cycles of identical length (equidistant) for PROFIBUS subnets. You will find a detailed description of equidistance in the STEP 7 online help.

Powering up the DP master system

You set power-up monitoring of the DP master with the following parameters:

- Downloading of the parameters to modules
- Completed message by module

In other words, the DP slaves have to power up within the set period and have to be parameterized by the CPU (as the DP master).

PROFIBUS address of the DP master

All PROFIBUS addresses are allowed.

From EN 50170 to DPV1

The EN 50170 standard for distributed I/O has been further developed. The results of this development are contained in IEC 61158 / IEC 61784-1:2002 Ed1 CP 3/1. In the SIMATIC documentation this is designated as DPV1. The new version contains a few enhancements and simplifications.

Some SIEMENS automatization components already feature DPV1 functionality. You will have to make a few modifications to your system in order to use the new functions. A full description of the conversion from EN 50170 to DPV1 is available as an FAQ entitled "Converting to DPV1", FAQ contribution ID 7027576 at our Customer Support Internet site.

Components that support the Profibus DPV1 functionality

DPV1 Master

- CPU 412-2 PCI/CPU 416-2 PCI firmware version 3.0 or later

DPV1 Slaves

- DP slaves, which can be found in the STEP 7 hardware -Katalog under their family names, are indicated in the information text as DPV1 slaves.
- DP slaves, which are integrated in STEP 7 through GSD files beginning with GSD revision 3.

STEP 7

STEP 7 V5.1, SP 2 or later

What operating modes are available for DPV1 components?

- S7 compatible mode
In this mode the components are compatible to EN 50170. However, you do not have full use of the DPV1 functions.
- DPV1 mode
In this mode you have use of the DPV1 functions. You can continue to use as usual the automation components in the station that do not support DPV1.

Compatibility between DPV1 and EN 50170?

You can continue to use all of the existing slaves after converting to DPV1. However, they will not support the enhanced functions of DPV1.

You can even use the DPV1 slaves without converting to DPV1. They will then react like conventional slaves. SIEMENS DPV1 slaves can be operated in the S7 compatible mode. For DPV1 slaves from other manufacturers you need a GSD file conforming to EN 50170 earlier than revision 3.

Converting to DPV1

When you convert to DPV1, you must convert the entire station to DPV1. You can set this in STEP 7 in the hardware configuration (DP mode).

Determining the bus topology in a DP master system using SFC 103 "DP_TOPOL"

The diagnostics repeater is available to improve your ability to detect faults during ongoing operation, for example, to identify a specific faulty module or the exact location of a break in the DP cable. This module is a slave that determines the topology of a DP segment and can register faults that may occur within it.

SFC 103 "DP_TOPOL" is used to trigger determination of the DP master system's bus topology using the diagnostics repeater. SFC 103 is described in the corresponding online help and in the "System and Standard Functions" manual. The diagnostics repeater is described in the manual, "Diagnostics Repeater for PROFIBUS-DP", Order Number 6ES7972-0AB00-8AA0.

Updating the process image partition synchronous to the the DP clock

SFC 126 "SYNC_PI" allows you to update a process image partition of the inputs synchronous to the DP clock. A user program operating with the DP clock can use this SFC to continually update the acquired input data in a process image partition of the inputs synchronous to this clock.

SFC 127 "SYNC_PO" allows you to update a process image partition of the outputs synchronous to the DP clock. A user program operating with the DP clock can use this SFC to continually forward the calculated output data of a process image partition of the outputs to the I/O synchronous to this clock.

In order to update process image partitions synchronous to the clock, all input and out addresses of a slave must be assigned to the same process image partition.

To ensure the integrity in a process image partition during each clock pulse, the following conditions must be fulfilled for each individual CPU:

- CPU 412: number of slaves + number of bytes / 100 < 10
- CPU 416: number of slaves + number of bytes / 50 < 26

SFC 126 and 127 are described in the corresponding online help and in the "System and Standard Functions" manual.

6.3 Diagnostics of CPU 41x-2 PCI as DP master

Diagnostics by means of LED displays

Table 6-2 explains the meaning of the BUSF LED.

In the event of a display, the BUSF LED that has been assigned to the interface configured as the PROFIBUS-DP interface will always light or flash.

Table 6-2 Meaning of "BUSF" LED of CPU 41x-2 PCI as DP Master

| BUSF | Description | Remedy |
|---------|--|---|
| Off | Configuration in order; all configured slaves can be addressed | – |
| Lights | <ul style="list-style-type: none"> • Bus fault (physical fault) • DP interface error • Different transmission rates in multi-DP master mode | <ul style="list-style-type: none"> • Check the bus cable for short-circuit or interruption. • Evaluate the diagnostics. Reconfigure, or correct the configuration. |
| Flashes | <ul style="list-style-type: none"> • Station failure • At least one of the assigned slaves cannot be addressed | <ul style="list-style-type: none"> • Check whether the bus cable is connected to the CPU 41x-2 PCI or the bus has been interrupted. • Wait until the CPU 41x-2 PCI has powered up. If the LED does not stop flashing, check the DP slaves or evaluate the diagnostics of the DP slaves. |

Read out the in STEP 7

Table 6-3 Reading Out the Diagnostics in STEP 7

| DP Master | Block or Register in STEP 7 | Application | Refer to... |
|---------------|---------------------------------|--|--|
| CPU 41x-2 PCI | "DP Slave Diagnostics" register | Displays slave diagnostics in plain language at STEP 7 user interface | Refer to "diagnostics Hardware" in the STEP 7 online help and in the STEP 7 user manual |
| | SFC 13 "DPNRM_DG" | Reads out slave diagnostics (stores in data area of the user program) | For the configuration of CPU 41x-2 PCI refer to Section 6.5.4; for SFC refer to the reference manual <i>System and Standard Functions</i> for the configuration of other slaves refer to their description |
| | SFC 59 "RD_REC" | Reads out data records of S7 diagnostics (stores in data area of the user program) | Reference manual <i>System and Standard Functions</i> |
| | SFC 51 "RDSYSST" | Reads out part lists. Calls SFC 51 in the diagnostic interrupt with the HLL ID W#16#00B3 and reads out the HLL of the slave CPU. | |
| | SFB 52 "RDREC" | The following applies to DPV1 environment: Reads out data records of S7 diagnostics (stores in data area of the user program) | |
| | SFB 54 "RALRM" | The following applies to DPV1 environment: Reads out interrupt information within the corresponding interrupt OB | |

Evaluating diagnostics in the user program

The following figure shows you the steps you have to take so that you can evaluate the diagnostics in the user program.

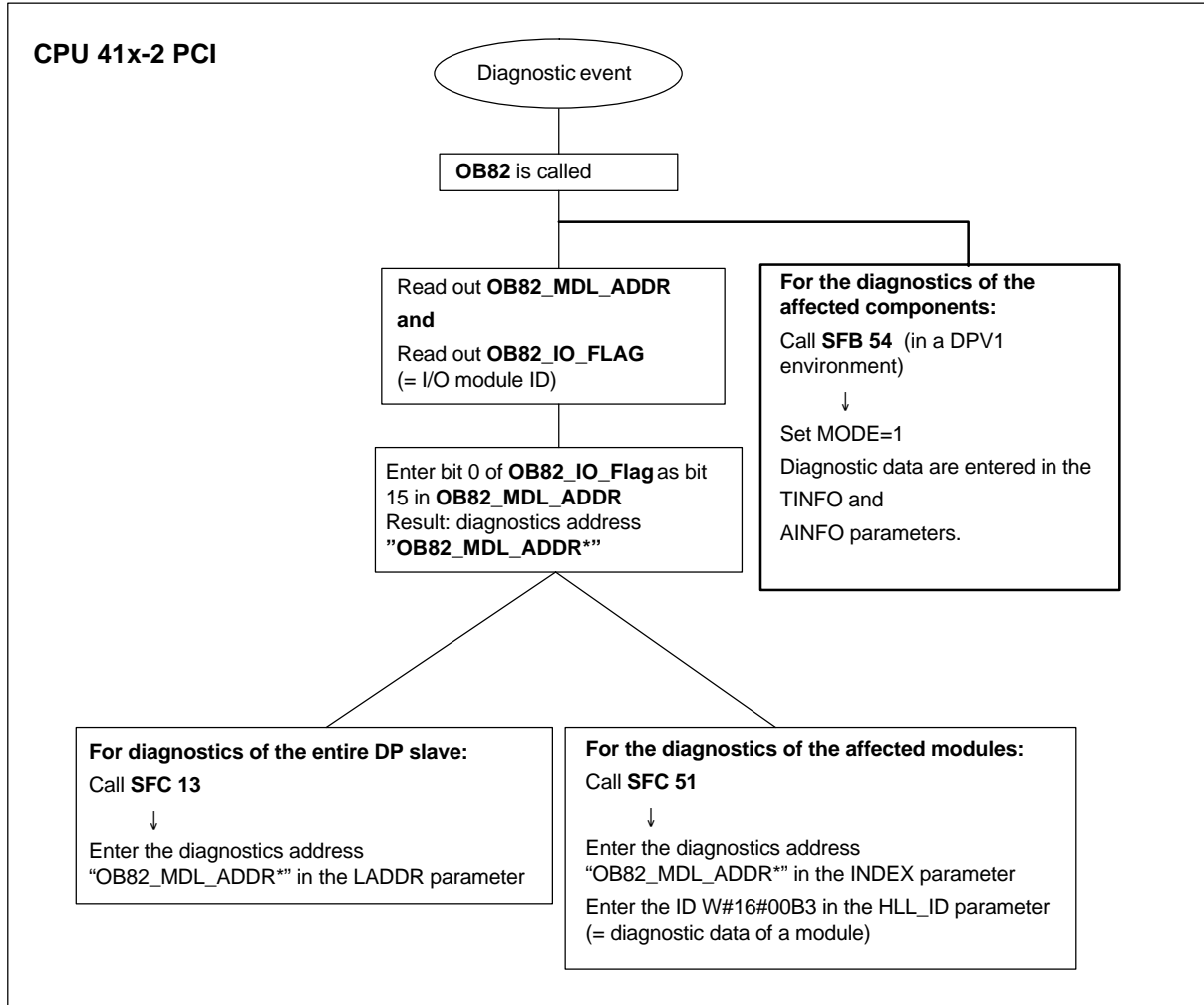

Figure 6-1 Diagnostics with CPU 41x-2 PCI

Diagnostics addresses in connection with DP master functionality

You assign diagnostics addresses for the PROFIBUS-DP with the CPU 41x-2 PCI. Bear in mind when you configuring that DP diagnostics addresses are assigned to the DP master and also to the DP slave.

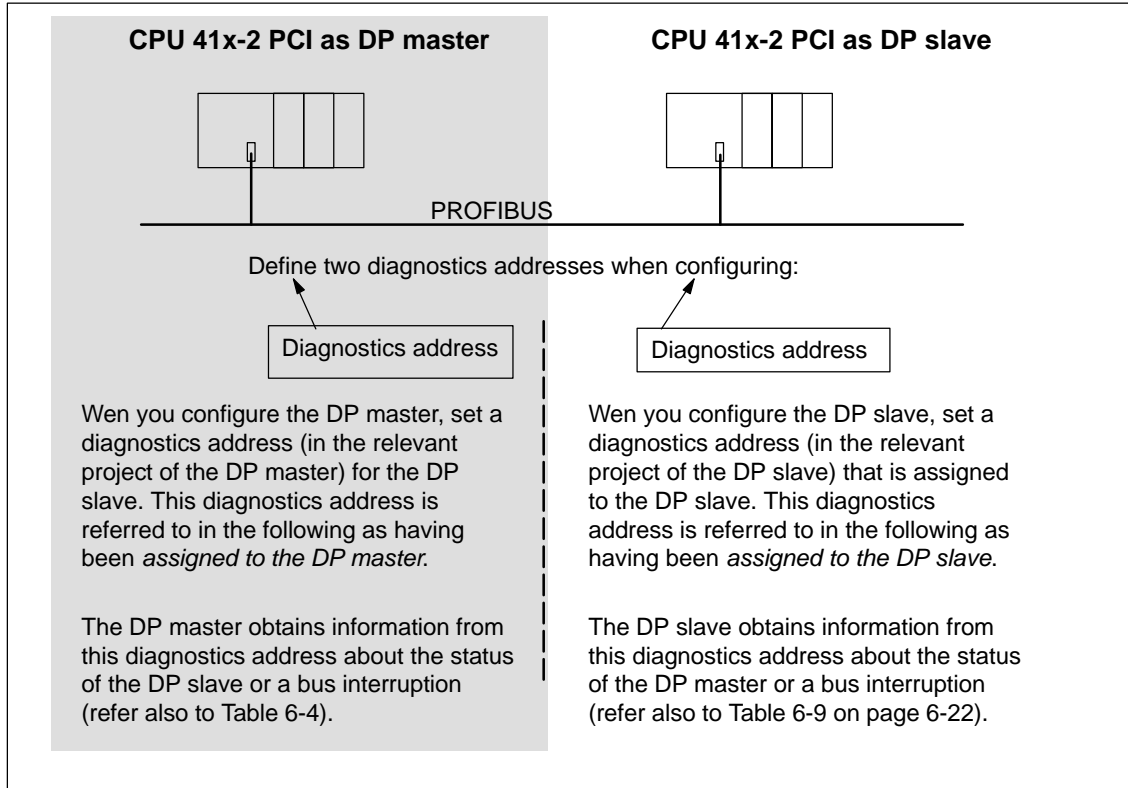

Figure 6-2 Diagnostics Addresses for DP Master and DP Slave

Event recognition

Table 6-4 shows how the CPU 41x-2 PCI, as a DP master, detects operating state changes of a CPU, as a DP slave, and interruptions of data transfer.

Table 6-4 Event Detection of CPUs 41x-2 PCI as DP Master

| | |
|---|---|
| Bus interruption (short-circuit, connector removed) | <ul style="list-style-type: none"> Calling of the OB 86 with the message <i>Station failure</i> (active event; diagnostics address of the DP slave assigned to the DP master) With I/O access: calling of OB 122 (I/O access error) |
| DP slave: RUN → STOP | <ul style="list-style-type: none"> Calling of OB 82 with the message <i>Module faulty</i> (active event; diagnostics address of the DP slave assigned to the DP master; tag OB82_MDL_STOP=1) |
| DP slave: STOP → RUN | <ul style="list-style-type: none"> Calling of OB 82 with the message <i>Module OK</i>. (cleared event; diagnostics address of the DP slave assigned to the DP master; tag OB82_MDL_STOP=0) |

Evaluating in the user program

The following table 6-5 shows you how you can analyze, for example, RUN/STOP transitions by the DP slave in the DP master (refer also to Table 6-4).

Table 6-5 Analysis of RUN/STOP Transitions in the DP Master/DP Slave

| In DP Master | In DP Slave (CPU 41x-2 PCI) |
|--|---|
| diagnostics addresses: (example) Master diagnostics address = 1023 Slave diagnostics address in master system= 1022 | Diagnostics addresses: (example) Slave diagnostics address = 422 Master diagnostics address = not applicable |
| The CPU calls OB 82 with the following information, among other things: <ul style="list-style-type: none"> OB 82_MDL_ADDR:=1022 OB82_EV_CLASS:=B#16#39 (active event) OB82_MDL_DEFECT:=module malfunction Tip: this information is similarly available in the diagnostic buffer of the CPU You should also program SFC 13 "DPNRM_DG" in the user program for reading out the DP slave diagnostics. We recommend that you use SFB54 in a DPV1 environment. It reads out the complete interrupt information. | ← CPU: RUN → STOP CPU generates a DP slave diagnostics message frame (refer to Section 6.5.4). |

6.4 CPU 41x-2 PCI as DP Slave

Introduction

In this chapter we describe the characteristics and technical specifications of the CPU when you are operating it as a DP slave.

You will find the characteristics and technical specifications of the CPUs in Section 8.2 and 8.3.

Requirements

1. Only one DP interface of a CPU can be configured as a DP slave at any time.
2. Do you want the MPI/DP interface to be a DP interface? If so, you must configure the interface as the DP interface.

You have to configure the CPU as the DP slave before starting to commission. This means that in *STEP 7* you have to

- "Enable" the CPU as a DP slave
- Assign a PROFIBUS address
- Assign a slave diagnostics address
- Define the address areas for data exchange with the DP master.

Device master (GSD) files

You require a device master file before you can configure the CPU as a DP slave on a third-party system.

You can download the device master file from the Internet at http://www.ad.siemens.de/csi_e/gsd.

Configuration and parameter assignment frame

When you configure/assign parameters to the CPU 41x-2 PCI, you are supported by *STEP 7*. Should you require a description of the configuration and parameter assignment frame – say, for checking with a bus monitor – you will find the description of the configuration and parameter assignment frame on the Internet at <http://www.ad.siemens.de/simatic-cs>; the contribution has the ID 1452338.

Status/Force, programming over PROFIBUS

As an alternative to the MPI, you can program the CPU through the PROFIBUS-DP interface, or you can execute the PG functions Status and Force. To do this, you must enable these functions in *STEP 7* when you are configuring the CPU as a DP slave.

Note

The use of programming or Status and Force through the PROFIBUS-DP interface increases the DP scan cycle time.

Data transfer using a transfer memory

The CPU 41x-2 PCI provided a transfer memory to PROFIBUS-DP as a DP slave. Data transfer between the CPU as a DP slave and the DP master is always performed with this transfer memory. For this, you configure up to 32 address areas.

In other words, the DP master writes its data to these address areas of the transfer memory and the CPU reads out these data in the user program, and the other way round.

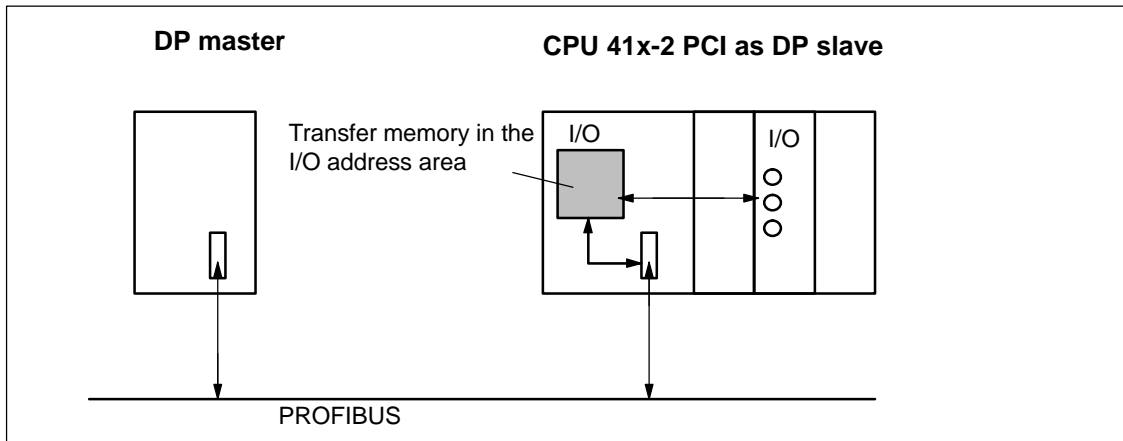

Figure 6-3 Transfer Memory in the CPU 41x-2 PCI as DP Slave

Address areas of the transfer memory

You configure input and output address areas in *STEP 7*:

- You can configure up to 32 input and output address areas
- The size of each of these address areas is limited to 32 bytes
- In all, you can configure up to 244 bytes for inputs and 244 bytes for outputs

The following table shows the principle of the address areas. You will find this figure in the *STEP 7* configuration, too.

Table 6-6 Configuration Example for the Address Areas of the Transfer Memory

| | Type | Master Address | Type | Slave Address | Length | Unit | Consistency |
|----|------|------------------------------------|------|-----------------------------------|--------|--|--------------|
| 1 | I | 222 | O | 310 | 2 | Byte | Unit |
| 2 | A | 0 | E | 13 | 10 | Word | Total length |
| : | | | | | | | |
| 32 | | | | | | | |
| | | Address areas in the DP master CPU | | Address areas in the DP slave CPU | | The parameters of the address areas must be identical for the DP master and DP slave | |

Rules

You must observe the following rules when working with the transfer memory:

- Assignment of the address areas:
 - Input data of the DP slave are **always** output data of the DP master
 - Output data of the DP slave are **always** input data of the DP master
- There are no constraints as far as the assignment of addresses is concerned. You access the data in the user program with load/transfer commands of with SFCs 14 and 15. You can also specify addresses from the process input or output image.

Note

You assign addresses from the DP address area of the CPU 41x-2 PCI.

The addresses assigned for the transfer memory must not be assigned a second time for the I/O modules on the CPU 41x-2 PCI.

- The lowest address of the different address areas is the start address of the address area concerned.
- The length, unit and consistency of the contiguous address areas must be identical for the DP master and the DP slave.

S5 DP master

If you are using an IM 308-C as the DP master and the CPU 41x-2 PCI as a DP slave, the following applies to the exchange of consistent data:

You must program FB 192 for the IM 308-C so that consistent data can be transferred between the DP master and the DP slave. FB 192 is used to output or read out the data of the CPU 41x-2 PCI only as one complete block.

S5-95U as DP master

If you are using an AG S5-95U as the DP master, you must set its parameters for the CPU 41x-2 PCI as a DP slave, too.

Example program

Below, you will see the exchange of data between the DP master and DP slave in a short example program. In this example, you will meet up again with the addresses which you first saw in Table 6-6.

| In DP Slave CPU | | | | In DP Master CPU | | | |
|-----------------|-----|-----|-----------------|------------------|-------------------------|-----|------------------|
| L | 2 | | Data smoothing | | | | |
| T | MB | 6 | in DP slave | | | | |
| L | IB | 0 | | | | | |
| T | MB | 7 | | | | | |
| L | FW | 6 | Forward data to | | | | |
| T | PAW | 310 | DP master | | | | |
| | | | | L | PEB | 222 | Further process |
| | | | | T | MB | 50 | received data in |
| | | | | L | PEB | 223 | DP master |
| | | | | L | B#16#3 | | |
| | | | | + | I | | |
| | | | | T | MB | 51 | |
| | | | | L | 10 | | Data smoothing |
| | | | | + | 3 | | in DP master |
| | | | | T | MB | 60 | |
| | | | | CALL | SFC | 15 | Send data to DP |
| | | | | | LADDR:= W#16#0 | | slave |
| | | | | | RECORD:= P#M60.0 Byte20 | | |
| | | | | | RET_VAL:= MW 22 | | |
| CALL | SFC | 14 | Receive data | | | | |
| | | | from DP master | | | | |
| | | | | | | | |
| | | | | | | | |
| | | | | | | | |
| L | MB | 30 | Further process | | | | |
| L | MB | 7 | received data | | | | |
| + | I | | | | | | |
| T | FW | 100 | | | | | |

Data transfer at STOP

The DP slave CPU goes to STOP: the data in the transfer memory of the CPU are overwritten with “0” – in other words, the DP master reads “0”.

The DP master goes to STOP: The current data in the transfer memory of the CPU are retained and can still be read out from the CPU.

PROFIBUS address

You must not set the “126” as the PROFIBUS address for the CPU 41x-2 PCI as a DP slave.

6.5 Diagnostics of CPU 41x-2 PCI as a DP Slave

In this section

| Section | Topic | Page |
|---------|---|------|
| 6.5.1 | Diagnostics by Means of LED Displays | 6-17 |
| 6.5.2 | Diagnostics with <i>STEP 5</i> or <i>STEP 7</i> | 6-18 |
| 6.5.3 | Reading Out the Diagnostics | 6-19 |
| 6.5.4 | Structure of Slave Diagnostics | 6-23 |
| 6.5.5 | Station Status 1 to 3 | 6-24 |
| 6.5.6 | Master PROFIBUS Address | 6-26 |
| 6.5.7 | Manufacturer's ID | 6-26 |
| 6.5.8 | Identifier-Related Diagnostics | 6-27 |
| 6.5.9 | Device-Related Diagnostics | 6-28 |
| 6.5.10 | Interrupts | 6-30 |

6.5.1 Diagnostics by Means of LED Displays

Diagnostics by means of LED displays – CPU 41x-2 PCI

Table 6-7 explains the meaning of the BUSF LEDs.
The BUSF LED that has been assigned to the interface configured as the PROFIBUS-DP interface will always light or flash.

Table 6-7 Meaning of the "BUSF" LEDs of CPU 41x-2 PCI as DP Slave

| BUSF | Description | Remedy |
|---------|--|---|
| Off | Configuration in order | – |
| Flashes | <p>The CPU 41x-2 PCI has been parameterized wrongly. Data are not being exchanged between the DP master and the CPU 41x-2 PCI.</p> <p>Causes:</p> <ul style="list-style-type: none"> • The watchdog timer has elapsed • Bus communications over PROFIBUS have been interrupted • PROFIBUS address is wrong | <ul style="list-style-type: none"> • Check the CPU 41x-2 PCI • Check whether the bus connector has been inserted properly • Check whether the bus cable to the DP master has been interrupted • Check the configuration and parameter assignment. |
| Lights | <ul style="list-style-type: none"> • Bus short-circuit | <ul style="list-style-type: none"> • Check the bus architecture |

6.5.2 Diagnostics with *STEP 5* or *STEP 7*

Slave diagnostics

The slave diagnostics conforms to standard EN 50170, Volume 2, PROFIBUS. It can be read out as a function of the DP master for all DP slaves conforming to the standard with *STEP 5* or *STEP 7*.

The following sections describe how the slave diagnostics is read out and how it is structured.

S7 diagnostics

A S7 diagnostics can be requested in the user program by all modules in the SIMATIC S7/M7 range of modules with diagnostics capability. To determine whether a module has diagnostics capability, you can refer to the information about the module or to the catalog. The structure of the S7 diagnostics is identical for centrally and distributed plugged module.

The diagnostic data of a module are located in data records 0 and 1 of the system data area of the module. Data record 0 contains 4 bytes of diagnostic data, which describe the current status of a module. Data record 1 additionally contains board-specific diagnostic data.

You will find the structure of the diagnostic data in the reference manual *Standard and System Functions*.

6.5.3 Reading out the Diagnostics

Table 6-8 Reading Out the Diagnostics in *STEP 5* and *STEP 7* in the Master System

| Automation System with DP Master | Block or Register in <i>STEP 7</i> | Application | Refer to... |
|---|------------------------------------|--|---|
| SIMATIC S7/M7 | "DP Slave Diagnostics" register | Displays slave diagnostics in plain language at <i>STEP 7</i> user interface | Refer to "diagnostics Hardware" in the <i>STEP 7</i> online Help and in the <i>STEP 7</i> user manual |
| | SFC 13 "DP NRM_DG" | Reads out slave diagnostics (stores in data area of the user program) | For the structure refer to Section 6.5.4; for SFCs refer to the reference manual <i>System and Standard Functions</i> |
| | SFC 51 "RDSYSST" | Reads out part lists. Calls SFC 51 in the diagnostic interrupt with the HLL ID W#16#00B3 and reads out the HLL of the slave CPU. | Reference manual <i>System and Standard Functions</i> |
| | SFB 54 "RDREC" | The following applies to the DPV1 environment: reads out interrupt information within the associated interrupt OB | |
| | FB 125/FC 125 | Analyses slave diagnostics | On the Internet at http://www.ad.siemens.de/simatic-cs ID 387 257 |
| SIMATIC S5 with IM 308-C as DP master | FB 192 "IM308C" | Reads out slave diagnostics (stores in data area of the user program) | For the structure refer to Section 6.5.4; for the FBs refer to the manual <i>Distributed I/O System ET 200</i> |
| SIMATIC S5 with programmable logic controller S5-95U as DP master | SFB 230 "S_DIAG" | | |

Example of reading out the slave diagnostics with FB 192 “IM 308C”

Here you will find an example of how you can read out the slave diagnostics with FB 192 for a DP slave in the *STEP 5* user program.

Assumptions

The following assumptions apply to this *STEP 5* user program:

- As DP master, the IM 308-C occupies pages 0 to 15 (number 0 of the IM 308-C).
- The PROFIBUS address of the DP slave is 3.
- The slave diagnostics is to be stored in DB 20. Alternatively, you can use any other data block for it.
- The slave diagnostics consists of 26 bytes.

STEP 5 user program

| STL | Explanation |
|-----------------|--|
| :A DB 30 | |
| :SPA FB 192 | |
| Name :IM308C | |
| DPAD : KH F800 | Default address area of the IM 308-C |
| IMST : KY 0, 3 | IM No. = 0, PROFIBUS address of the DP slave = 3 |
| FCT : KC SD | Function: Read Slave Diagnostics |
| GCGR : KM 0 | Is not analyzed |
| TYPE : KY 0, 20 | S5 data area: DB 20 |
| STAD : KF +1 | Diagnostic data from data word 1 |
| LENG : KF 26 | Diagnostics length = 26 bytes |
| ERR : DW 0 | Error code stored in DW 0 of DB 30 |

Diagnostics addresses in connection with DP slave functionality

You assign diagnostics addresses for the PROFIBUS-DP with the CPU 41x-2 PCI. Bear in mind when you configuring that DP diagnostics addresses are assigned to the DP master and also to the DP slave.

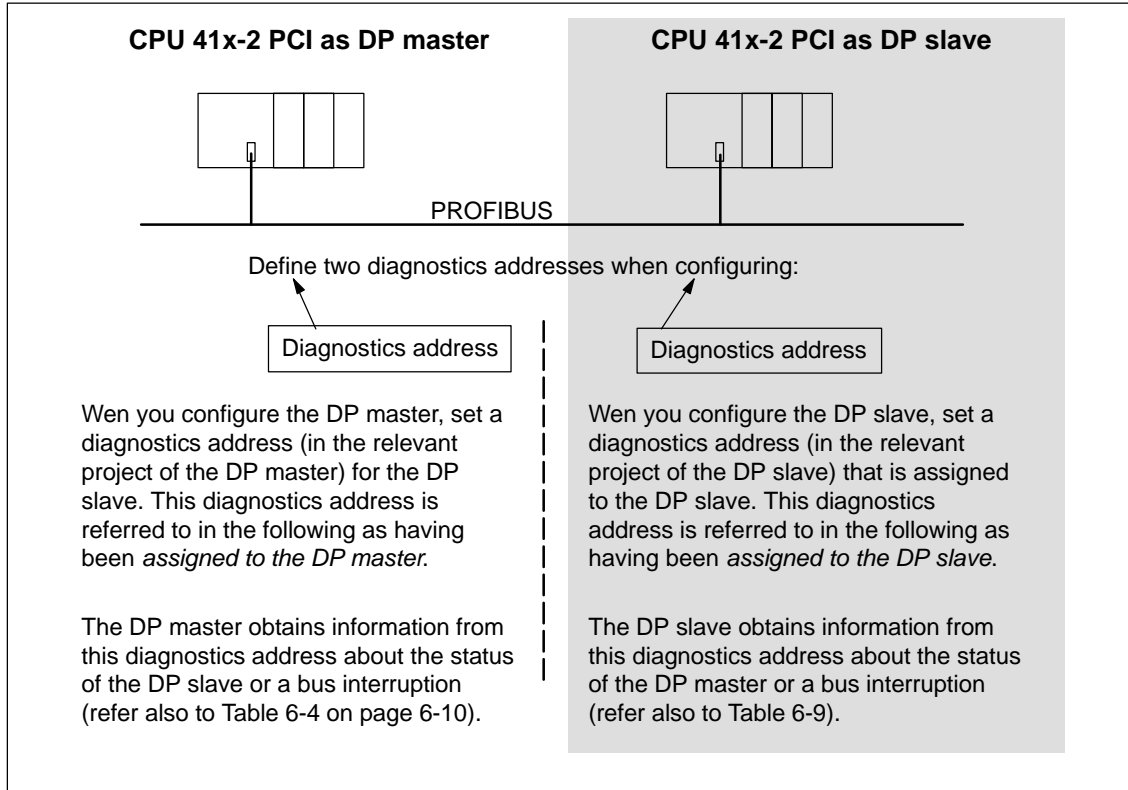

Figure 6-4 Diagnostics Addresses for DP Master and DP Slave

Event recognition

Table 6-9 shows how the CPU 41x-2 PCI, as a DP slave, detects operating state changes and interruptions of data transfer.

Table 6-9 Event Detection of CPUs 41x-2 PCI as DP Slave

| | |
|---|--|
| Bus interruption (short-circuit, connector removed) | <ul style="list-style-type: none"> Calling of the OB 86 with the message <i>Station failure</i> (active event; diagnostics address of the DP slave assigned to the DP slave) With I/O access: calling of OB 122 (I/O access error) |
| DP master: RUN → STOP | <ul style="list-style-type: none"> Calling of OB 82 with the message <i>Module faulty</i> (active event; diagnostics address of the DP slave assigned to the DP slave; tag OB82_MDL_STOP=1) |
| DP master: STOP → RUN | <ul style="list-style-type: none"> Calling of OB 82 with the message <i>Module OK</i>. (cleared event; diagnostics address of the DP slave assigned to the DP slave; tag OB82_MDL_STOP=0) |

Evaluating in the user program

The following table 6-10 shows you how you can analyze, for example, RUN/STOP transitions by the DP master in the DP slave (refer also to Table 6-9).

Table 6-10 Analysis of RUN/STOP Transitions in the DP Master/DP Slave

| In DP Master | In DP Slave |
|---|---|
| Diagnostics addresses: (example) Master diagnostics address = 1023 Slave diagnostics address in master system= 1022 | Diagnostics addresses: (example) Slave diagnostics address = 422 Master diagnostics address = not applicable |
| CPU: RUN → STOP | The CPU calls OB 82 with the following information, among other things: <ul style="list-style-type: none"> OB 82_MDL_ADDR:=422 OB82_EV_CLASS:=B#16#39 (active event) OB82_MDL_DEFECT:=module malfunction Tip: this information is similarly available in the diagnostic buffer of the CPU |

6.5.4 Structure of Slave Diagnostics

Structure of slave diagnostics

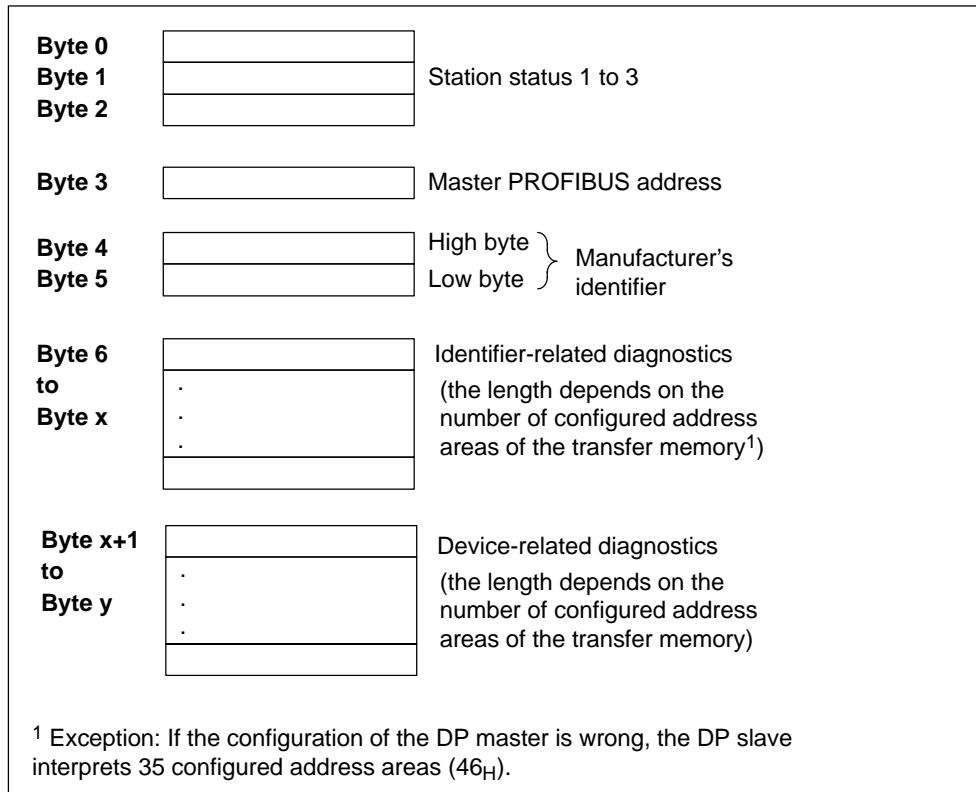

Figure 6-5 Structure of Slave Diagnostics

6.5.5 Station Status 1 to 3

Definition

The station status, 1 to 3, gives an overview of the state of a DP slave.

Station status 1

Table 6-11 Structure of Station Status 1 (Byte 0)

| Bit | Description | Remedy |
|-----|--|--|
| 0 | 1: DP slave can not be addressed by the DP master. | <ul style="list-style-type: none"> • Correct DP address set at DP slave? • Bus connector plugged in? • Voltage at DP slave? • RS 485 repeater adjusted correctly? • Perform Reset on DP slave |
| 1 | 1: DP slave is not yet ready for data exchange. | <ul style="list-style-type: none"> • Wait, the DP slave is currently powering up. |
| 2 | 1: The configuration data sent by the DP master to the DP slave do not correspond to the configuration of the DP slave. | <ul style="list-style-type: none"> • Correct station type or correct configuration of the DP slave entered in the software? |
| 3 | 1: Diagnostic interrupt, generated by RUN/STOP transition of the CPU 0: Diagnostic interrupt, generated by STOP/RUN transition of the CPU | <ul style="list-style-type: none"> • You can read out the diagnostics. |
| 4 | 1: Function not supported – for example, change of the DP address by software | <ul style="list-style-type: none"> • Check the configuration. |
| 5 | 0: The bit is always "0". | – |
| 6 | 1: DP slave type does not conform to software configuration. | <ul style="list-style-type: none"> • Correct station type entered in the software? (Parameterization error) |
| 7 | 1: DP slave assigned parameters by a different DP master from the DP master that is currently accessing the DP slave. | <ul style="list-style-type: none"> • Bit is always 1 if, for example, you are just accessing the DP slave with the PG or with another DP master. The DP address of the parameterization master is located in the diagnostic byte "Master PROFIBUS Address". |

Station status 2

Table 6-12 Structure of Station Status 2 (Byte 1)

| Bit | Description |
|-----|--|
| 0 | 1: DP slave must be re-parameterized and configured. |
| 1 | 1: There is a diagnostic message. The DP slave cannot run any more until the error has been cleared (static diagnostic message). |
| 2 | 1: Bit is always at "1" if there is a DP slave having this DP address. |
| 3 | 1: The watchdog for this DP slave is enabled. |
| 4 | 0: The bit is always at "0". |
| 5 | 0: The bit is always at "0". |
| 6 | 0: The bit is always at "0". |
| 7 | 1: DP slave is disabled – in other words, it has been removed from cyclic processing. |

Station status 3

Table 6-13 Structure of Station Status 3 (Byte 2)

| Bit | Description |
|--------------|--|
| 0 to 6 | 0: Bits are always at "0" |
| 7 | 1: <ul style="list-style-type: none"> • There are more diagnostic messages than the DP slave can save. • The DP master cannot enter all the diagnostic messages sent by the DP slave in its diagnostic buffer. |

6.5.6 Master PROFIBUS Address

Definition

The diagnostic byte Master PROFIBUS Address stores the DP address of the DP master which:

- has parameterized the DP slave; and
- has read and write access to the DP slave

Master PROFIBUS address

Table 6-14 Structure of the Master PROFIBUS Address (Byte 3)

| | |
|--------|--|
| | |
| 0 to 7 | DP address of the DP master that parameterized the DP slave and has read and write access to the DP slave. |
| | FF _H : DP slave has not been parameterized by any DP master. |

6.5.7 Manufacturer's ID

Definition

The manufacturer's ID stores a code, which describes the type of the DP slave.

Manufacturer's ID

Table 6-15 Structure of the Manufacturer's ID (Bytes 4, 5)

| | | |
|-----------------|-----------------|---------------|
| | | |
| 80 _H | CE _H | CPU 412-2 PCI |
| 80 _H | CF _H | CPU 416-2 PCI |

6.5.8 Identifier-Related Diagnostics

Definition

Identifier-related diagnostics provides information about the configured address area of the transfer memory for which an entry has been made.

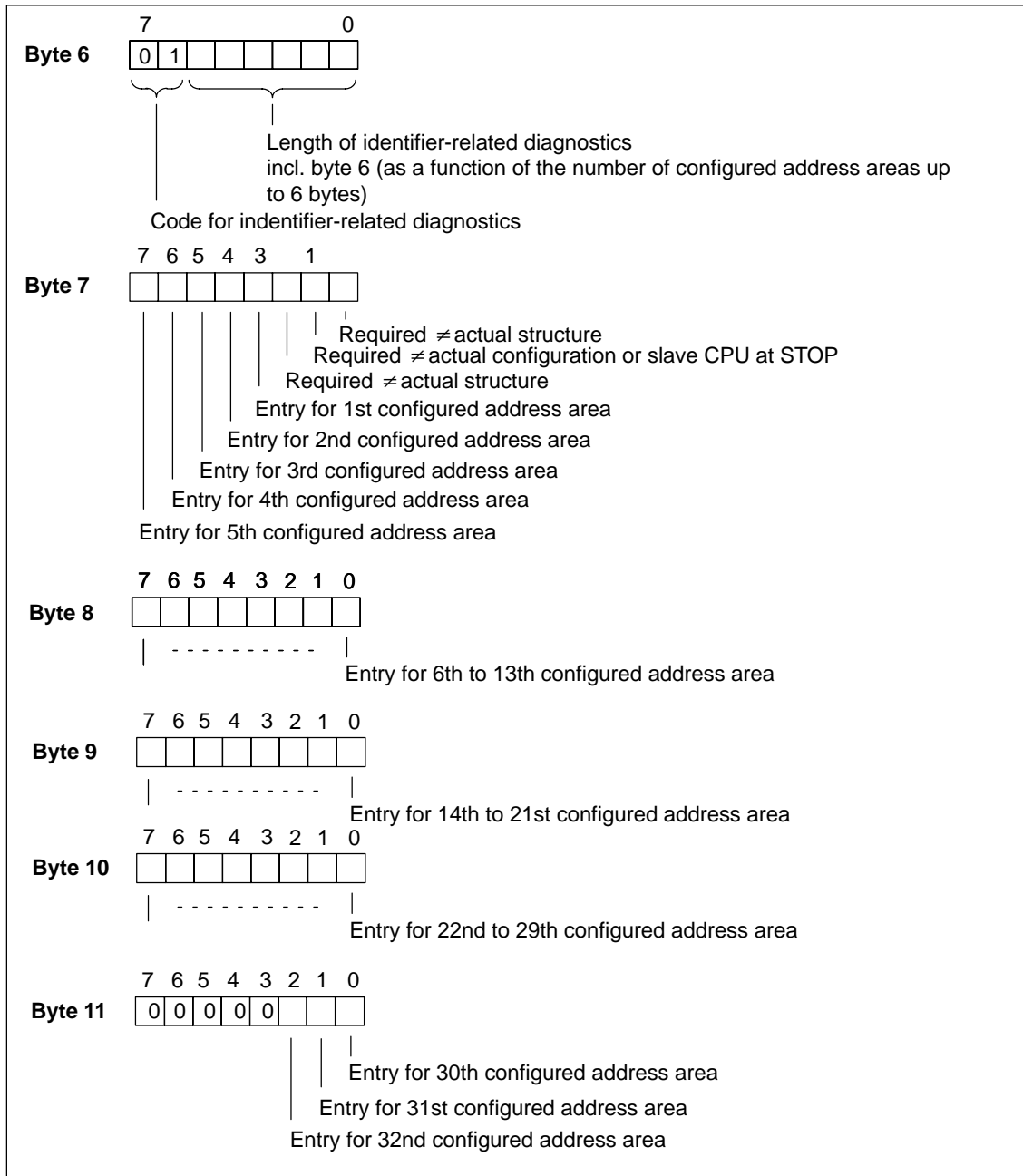

Figure 6-6 Structure of Identifier-Related Diagnostics of CPU 41x-2 PCI

6.5.9 Device-Related Diagnostics

Definition

Device-related diagnostics provides information about a DP slave. Device-related diagnostics starts at byte x and can include up to 20 bytes.

Device-related diagnostics

The following figure shows the structure and contents of the bytes for a configured address area of the transfer memory.

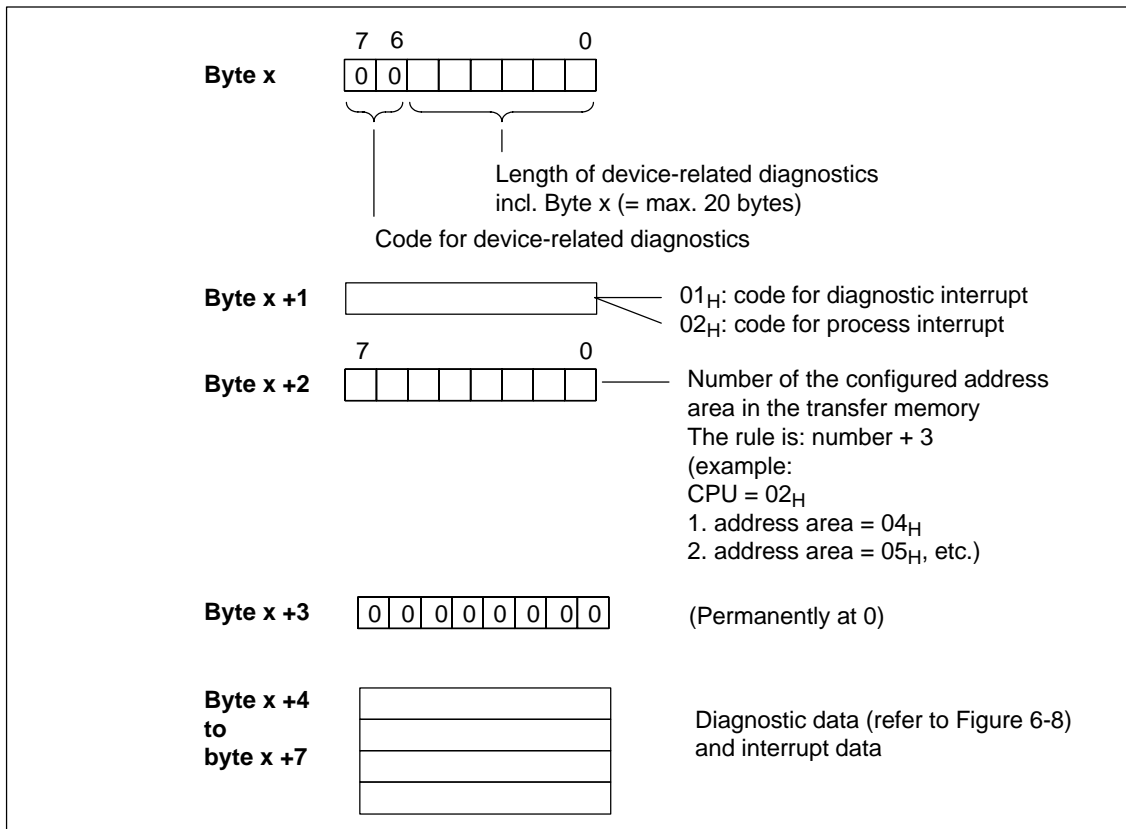

Figure 6-7 Structure of Device-Related Diagnostics

Form byte x +4

The meaning of the bytes from x + 4 depends on byte x + 1 (refer to Figure 6-7).

| Byte x +1 contains the code for... | |
|---|--|
| Diagnostic interrupt (01 _H) | Process interrupt (02 _H) |
| The diagnostic data contain the 16 bytes of status information relating to the CPU. In Figure 6-8 we show you the assignment of the first four bytes of the diagnostic data. The 12 bytes that follow are always 0. | You can program four bytes of interrupt information for the process interrupt. You transfer these four bytes in <i>STEP 7</i> to the DP master with SFC 7 "DP_PRAL" (refer to Section 6.5.10). |

Bytes x +4 to x +7 for diagnostic interrupt

Figure 6-8 shows the structure and contents of bytes x +4 to x +7 for diagnostic interrupt. The contents of these bytes correspond to the contents of data record 0 of diagnostics in *STEP 7* (not all bits are assigned in this case).

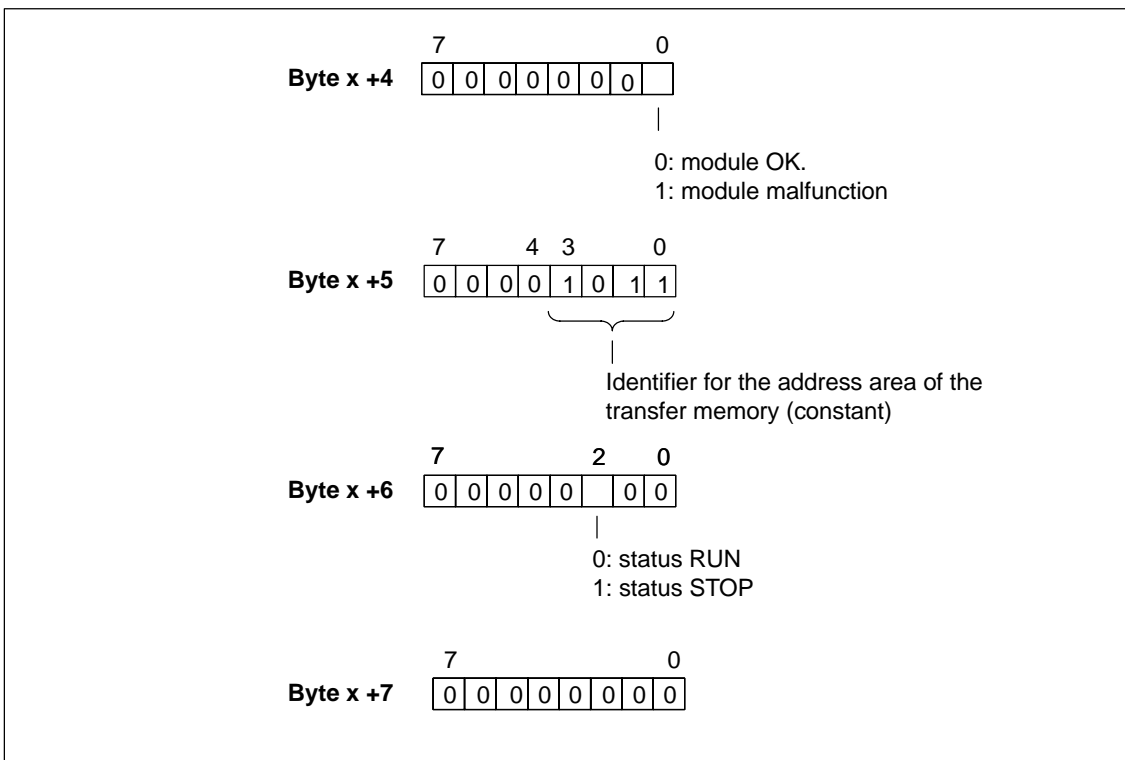

Figure 6-8 Bytes x +4 to x +7 for Diagnostic and Process Interrupts

6.5.10 Interrupts

Interrupts with S7/M7 DP master

In CPU 41x-2 PCI as a DP slave, you can trigger a process interrupt on the DP master in the user program. By calling SFC 7 “DP_PRAL”, you trigger an OB 40 in the user program of the DP master. Using SFC 7, you can forward interrupt information in a double word to the DP master, it being possible for you to analyze the information in OB 40, in tag OB40_POINT_ADDR. You can program the interrupt information. You will find a detailed description of SFC 7 “DP_PRAL” in the reference manual *System Software for S7-300/400 - System and Standard Functions*.

Interrupts with a different DP master

Should you operate the CPU 41x-2 PCI with a different DP master, these interrupts are simulated within the device-related diagnostics of the CPU 41x-2 PCI. You must process the corresponding diagnostics events in the user program of the DP master.

Note

In order to be able to analyze the diagnostic interrupt and the process interrupt by means of device-related diagnostics with a different DP master, you must take note of the following:

- The DP master should be capable of storing the diagnostic messages – in other words, the diagnostic messages should be stored in a ring buffer within the DP master. If the DP master cannot save the diagnostic messages, only the last diagnostic message to be received will ever be stored, for example.
 - You must query the corresponding bits in the device-related diagnostics on a regular basis in your user program. When doing so, you must also take the bus transit time of PROFIBUS-DP into account so that you can query the bits, say, at least once synchronously with the bus transit time.
 - Using an IM 308-C as a DP master, you cannot use process interrupts within the device-related diagnostics, since only active – not cleared – interrupts are reported.
-

6.6 Direct Data Exchange

In *STEP 7 v.5.x* and higher, you can configure “Direct Data Exchange” for PROFIBUS nodes. The CPUs 41x-2 PCI can participate in the direct data exchange as sender and receiver

“Direct Data Exchange” is a specific communication relationship between PROFIBUS-DP nodes.

Principle

Direct Data Exchange is characterized by the fact that the PROFIBUS-DP nodes “listen in” to find out which data a DP slave is sending back to its DP master. Using this function the eavesdropper (receiver) can directly access changes in the input data of remote DP slaves.

When configuring in *STEP 7*, you use the remote input addresses to set the address area of the receiver to which the required data from the sender have to be read.

A CPU 41x-2 PCI can be:

Sender as DP slave

Receiver as DP slave or DP master, or as a CPU that is not integrated in a master system (refer to Figure 6-9).

Example:

Figure 6-9 shows an example of the Direct Data Exchange “relationships” that you can configure. In the figure, all DP masters and DP slaves are CPUs 41x-2 PCI. Note that other DP slaves (ET 200M, ET 200X, ET 200S) can only be senders.

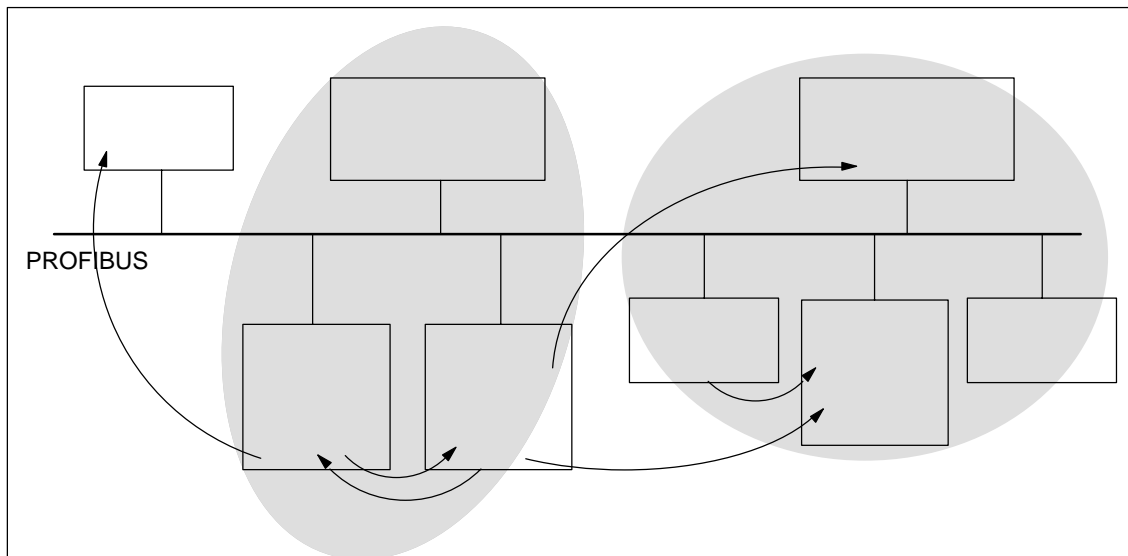

Figure 6-9 Direct Data Exchange with CPUs 41x-2 PCI

6.7 Diagnostics During Direct Data Exchange

Diagnostics addresses

During Direct Data Exchange, you assign a diagnostics address in the receiver:

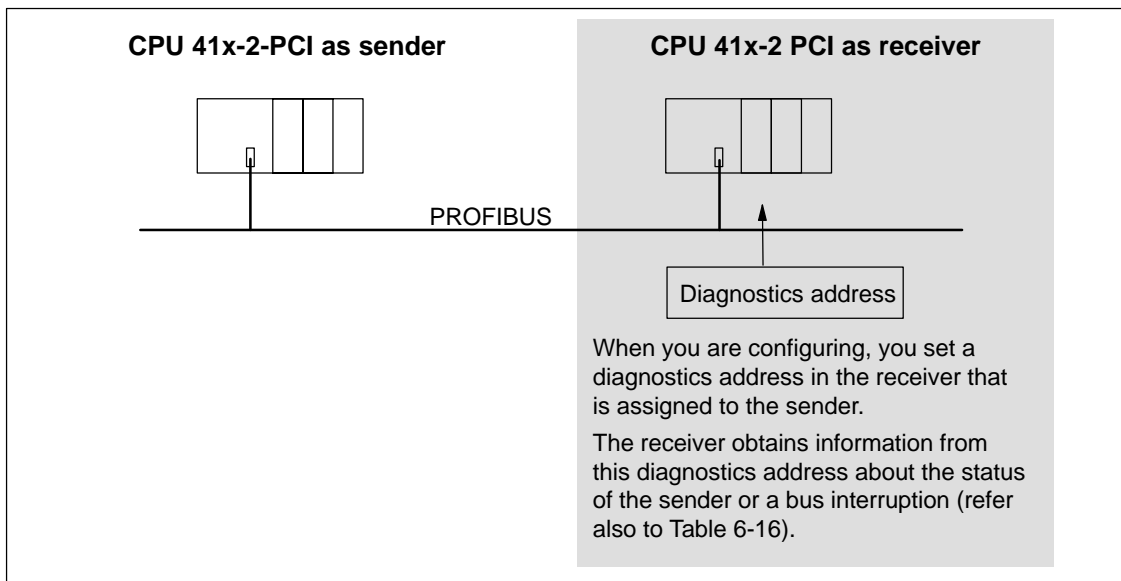

Figure 6-10 Diagnostics Address for the Receiver During Direct Data Exchange

Event recognition

Table 6-16 shows how the CPU 41x-2 PCI, as a receiver, detects operating state changes and interruptions of data transfer.

Table 6-16 Event Detection of CPUs 41x-2 PCI as Receivers During Direct Data Exchange

| | |
|---|--|
| | |
| Bus interruption (short-circuit, connector removed) | <ul style="list-style-type: none"> • Calling of the OB 86 with the message <i>Station failure</i> (active event; diagnostics address of the receiver assigned to the sender) • With I/O access: calling of OB 122 (I/O access error) |

Evaluating in the user program

The following table 6-17 shows you how you can analyze, for example, a station failure of the sender in the receiver (refer also to Table 6-16).

Table 6-17 Analysis of a Station Failure of the Sender During Direct Data Exchange

| In Sender | In Receiver |
|---|--|
| Diagnostics addresses: (example) Master diagnostics address = 1023 Slave diagnostics address in master system= 1022 | Diagnostics address: (example) Diagnostics address= 444 |
| Station failure | → The CPU calls OB 86 with the following information, among other things: <ul style="list-style-type: none"> • OB 86_MDL_ADDR:=444 • OB86_EV_CLASS:=B#16#38 (active event) • OB86_FLT_ID:=B#16#C4 (failure of a DP station) Tip: this information is similarly available in the diagnostic buffer of the CPU |

Time Synchronization (WinACTimeSync)

7

In this chapter

| Section | Contents | Page |
|---------|--|------|
| 7.1 | Overview | 7-2 |
| 7.2 | Assigning a CP to Time Synchronization | 7-4 |
| 7.3 | Using the Time Synchronization Service | 7-8 |
| 7.4 | User Example | 7-10 |

7.1 Overview

The CPU 41x-2 PCI can be synchronized together with other network nodes (for example, S7 components) by a central time transmitter.

The time synchronization service in the PC supplies the CPU at intervals with the current date and time. The-of-day transmitter furnishes the time of day at periodic intervals on the Industrial Ethernet or PROFIBUS-DP. The CP is thus synchronized in the PC.

There is further 2-end time synchronization, in which one node has to be set up as a slave and another as the master. You will find more information in the STEP 7 Help.

Note

The CPU 41x-2 PCI can only be operated as a time master through the integrated interfaces.

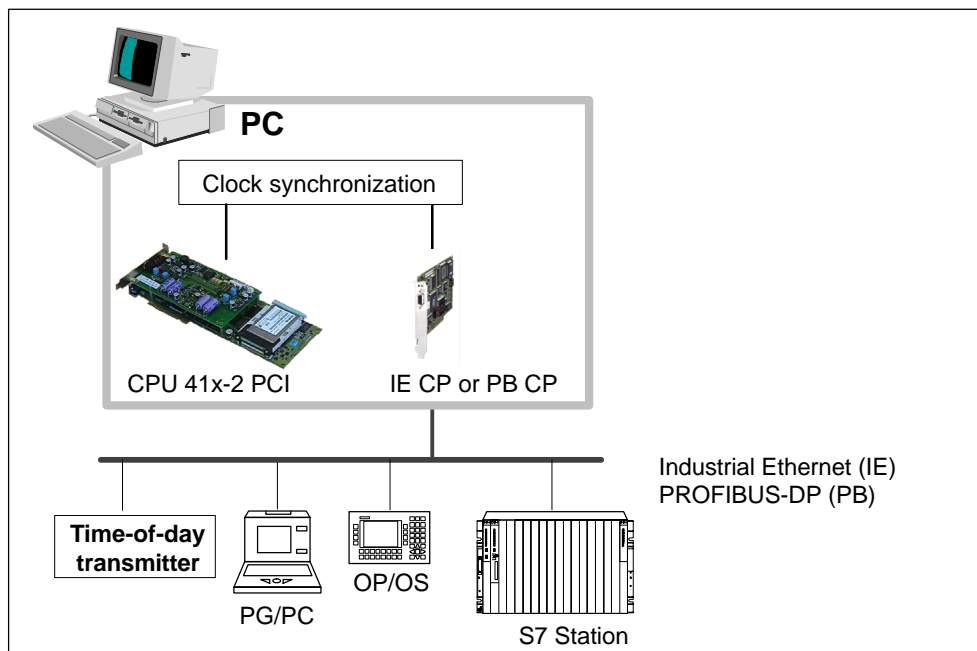

Figure 7-1 Clock Synchronization

Note

The time synchronization service is only provided for certain communication processors (CPs). You will find information on this in the Product Information document.

Requirements

The following hardware and software requirements must be met for the time synchronization service to work.

- The CPU 41x2 PCI must have been successfully installed.
- A communication processor (CP) must have been successfully installed together with the corresponding drivers.

Note

The driver for the communication processor (CP) must be installed using the associated setup program.

7.2 Assigning a CP to Time Synchronization

In this chapter

| Section | Contents | Page |
|---------|--------------------------|------|
| 7.2.1 | Setting the Access Point | 7-5 |
| 7.2.2 | Installing an Interface | 7-6 |

Once the software has been successfully installed, the time synchronization interface has to be configured. The communication peer for whom the time synchronization service is to be effective is defined.

The time synchronization service will not work unless the control panel of the CPU 41x-2 DP PCI and the driver of the corresponding CP are installed.

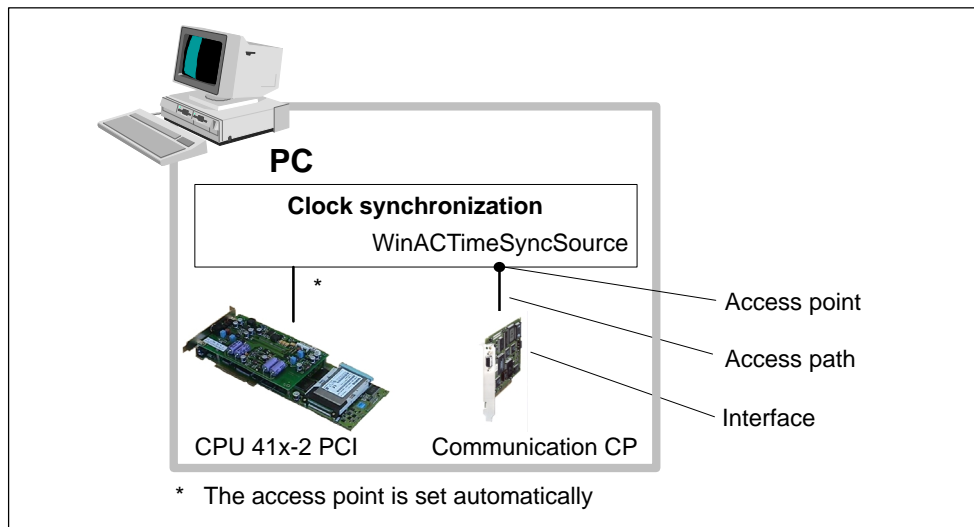

Figure 7-2 Configuring the Interfaces

To configure the two drivers, proceed as follows:

1. Open the control panel of the time synchronization service from the task bar:
Start > Simatic > PC Based Control > WinAC Time Synchronization
2. Click the "Set PG/PC Interface" button.

7.2.1 Setting the Access Point

Using the program "Set PG/PC Interface", you can set the interface parameters of the CP and connect to the access points made available.

To simplify the parameter assignment of the PG/PC interface, the time synchronization provides the predefined access point "WinACTimeSyncSource". It is displayed at "Access Point of the Application".

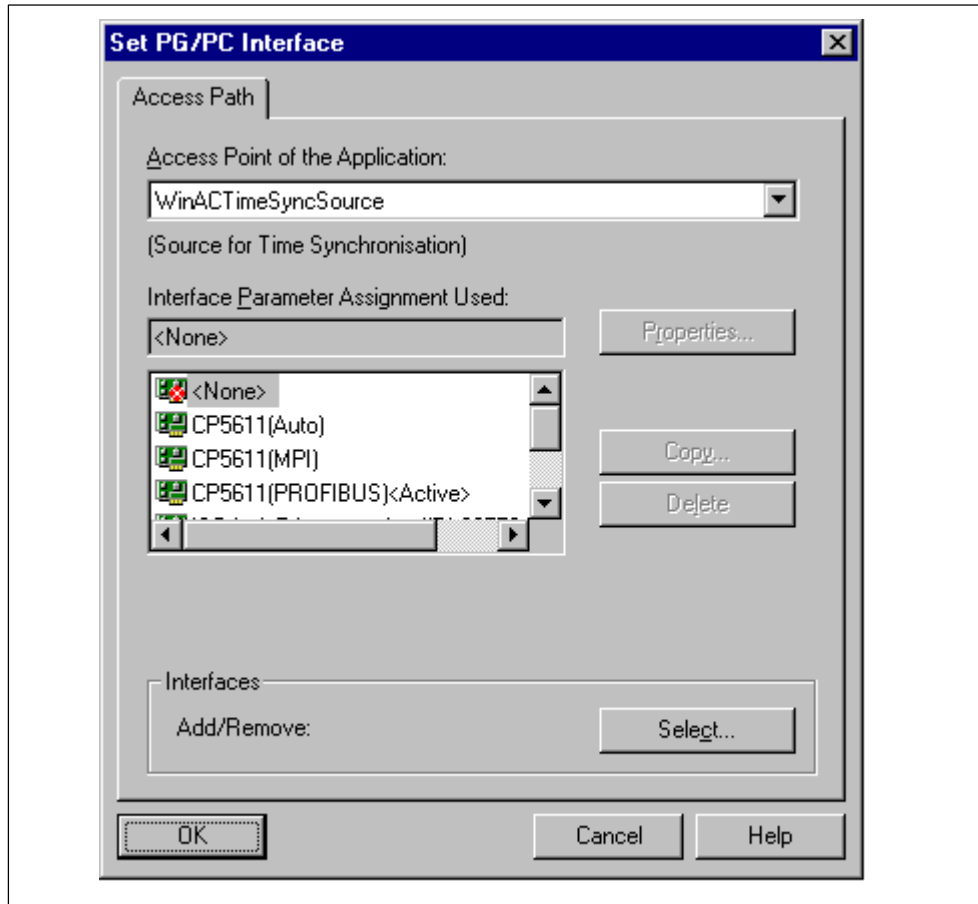

Figure 7-3 Setting the PG/PC Interface

Note

If the desired CP is not offered, you have to install it by clicking "Select..." (refer to section 7.2.2).

To set the access points, proceed as follows:

1. In the "Interface Parameter Assignment Used" list box, select the corresponding node CP depending on the desired communication network.
2. You set the properties of the CP using the SIMATIC NET commissioning wizard.

7.2.2 Installing an Interface

If the interface parameter assignment you require is not displayed, you must install the missing module by clicking the "Select..." button. The interface parameter assignment is then created automatically. Proceed as follows (you will find a detailed description in the online help system, which you access by pressing F1):

1. On the "Access Path" tab (in the "Set PG/PC Interface" dialog box), click the "Select..." button. The "Install/Uninstall Interfaces" dialog box appears.
2. Select the associated interfaces from the "Selection" list.
3. Click the "Install —>" button.

Note

Changes are also necessary if there are conflicts with other settings (for example, interrupt or address settings). If this is the case, perform the appropriate changes using the hardware detection facility and Control Panel in Windows.

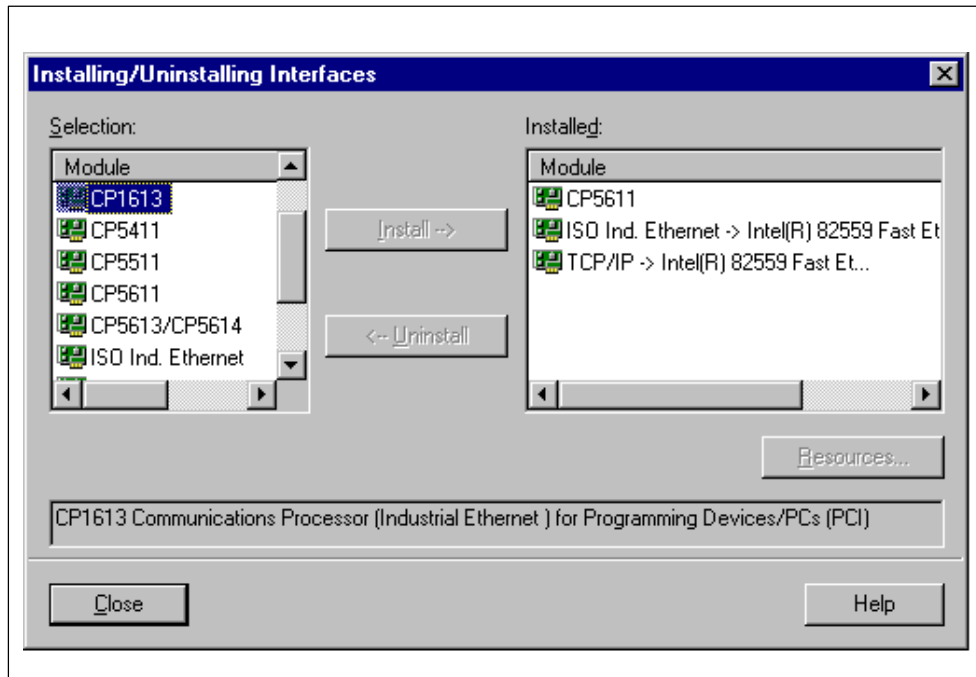

Figure 7-4 Installing/Uninstalling Interfaces

Note

After successful installation and configuration the service is started automatically each time Windows is started.

7.3 Using the Time Synchronization Service

In this chapter

| Section | Contents | Page |
|---------|---|------|
| 7.3.1 | Starting and Terminating Time Synchronization | 7-8 |
| 7.3.2 | Setting the Interval for Time Synchronization | 7-9 |

On the time synchronization user interface you can start and terminate the time synchronization service and set the interval.

7.3.1 Starting and Terminating Time Synchronization

After installation and configuration, time synchronization is active.

To disable time synchronization, proceed as follows:

1. Open the control panel of the time synchronization service by selecting it on the task bar:

Start > Simatic > PC Based Control > WinAC Time Synchronization

2. Exit time synchronization by clicking the "End" button. Time synchronization is now deactivated.
3. To start time synchronization again, click the "Start" button.

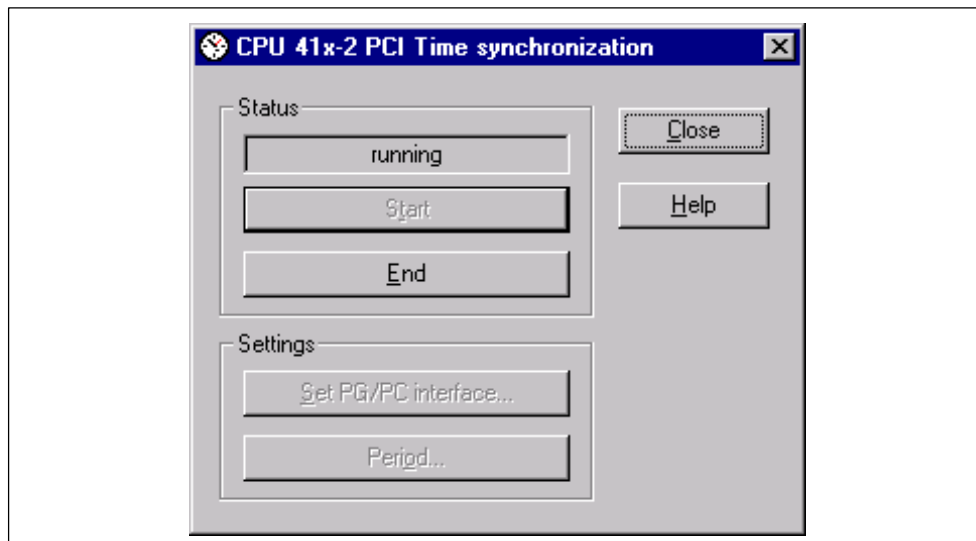

Figure 7-5 Starting/Exiting Time Synchronization

7.3.2 Setting the Interval for Time Synchronization

Using the time synchronization operator control panel, you can set the period of time after which the time on the SIMATIC S7 system will be updated.

Perform the following steps:

1. Open the control panel of the time synchronization service by selecting it on the task bar:

Start > Simatic > PC Based Control > WinAC Time Synchronization

2. Time synchronization must not be active when you set the interval. Terminate time synchronization before you make any changes.
3. Click the "Period" button.
4. Set one of the suggested intervals.

The time synchronization service updates the time when the specified interval elapses.

A period of between 1 minute and 24 hours can be set. The default value is 10 minutes.

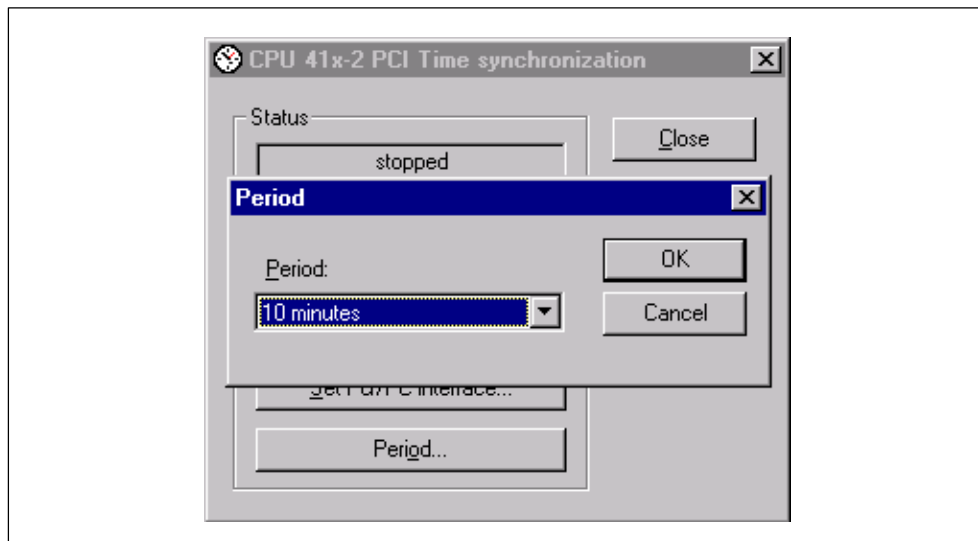

Figure 7-6 Setting the Period for Time Synchronization

Note

Since the time between the sender and recipient always diverges a little between the update times, a short interval results in frequent small jumps and a long interval in a few larger corrections. Sensible values are generally between 10 minutes and an hour.

7.4 User Example

In this chapter

| Section | Contents | Page |
|---------|---|------|
| 7.4.1 | Task: Communication Using Time Synchronization | 7-10 |
| 7.4.2 | Component Configurator: Configure PC Components within the PC | 7-11 |
| 7.4.3 | Commissioning wizard: assigning CP 5613 | 7-11 |
| 7.4.4 | Creating a Project | 7-14 |
| 7.4.5 | Configuring an Access Point | 7-23 |
| 7.4.6 | Starting Time Synchronization | 7-24 |

7.4.1 Task: Communication Using Time Synchronization

In the example, we want to synchronize a Box PC 620 to a CPU 416-2 PCI by a SIMATIC S7-400 station over PROFIBUS-DP.

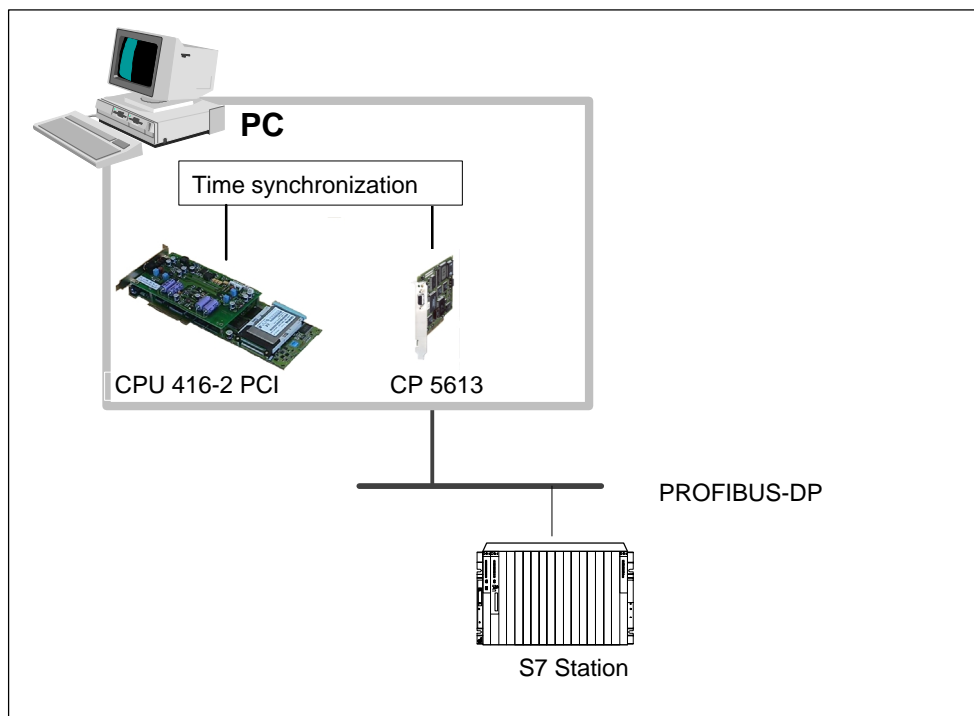

Figure 7-7 Communication Using Time Synchronization

7.4.2 Component Configurator: Configure PC Components Within the PC

To advise the PC which components have been plugged in

1. Open the component configurator by clicking on the



button on the taskbar.

Result: The component configurator opens.

Note

The following settings in the component configurator must match the subsequent configuration in “STEP 7/Configure Hardware”:

- Station name
- Type
- Index (corresponds to the slot in “Configure Hardware”) and
- Name.

2. Click on “Station name”.
3. Call the station “Box PC 620” and terminate by clicking “OK”.

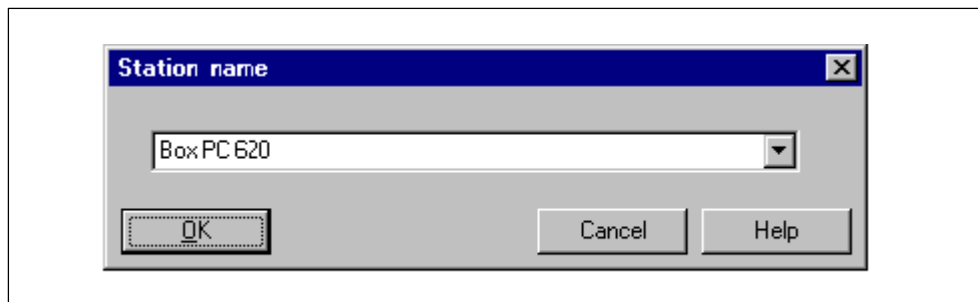

Figure 7-8 Component Configurator: Assigning Station Names

4. Exit the component configurator by clicking on “OK”.

7.4.3 Commissioning wizard: assigning CP 5613

Function of the commissioning wizard

You require the commissioning wizard to notify the CPs that have been plugged in to the PC.

Note

The settings in the commissioning wizard must be identical to those in the subsequent configuration in “STEP 7/Configure Hardware”.

Information about the commissioning wizard

You will find more information about the commissioning wizard in the associated documentation and in the online Help.

Procedure

To configure the CP 5613 for operation within the PC, perform the following steps:

1. Open the commissioning wizard by choosing **Start > SIMATIC > SIMATIC NET > Settings > Commissioning Wizard** from the menu.

Result: The “SIMATIC NET Commissioning Wizard” window opens.

2. Click on “Next”.

Result: The “PC Station Configuration” window opens.

3. Fill out the settings for the CP 5613 as shown in the figure below and confirm by clicking “Next”.

Note

The settings (index, MAC address, IP address, subnet mask) must be identical to those in “STEP 7/Configure Hardware”. The index in “STEP 7/Configure Hardware” corresponds to the slot.

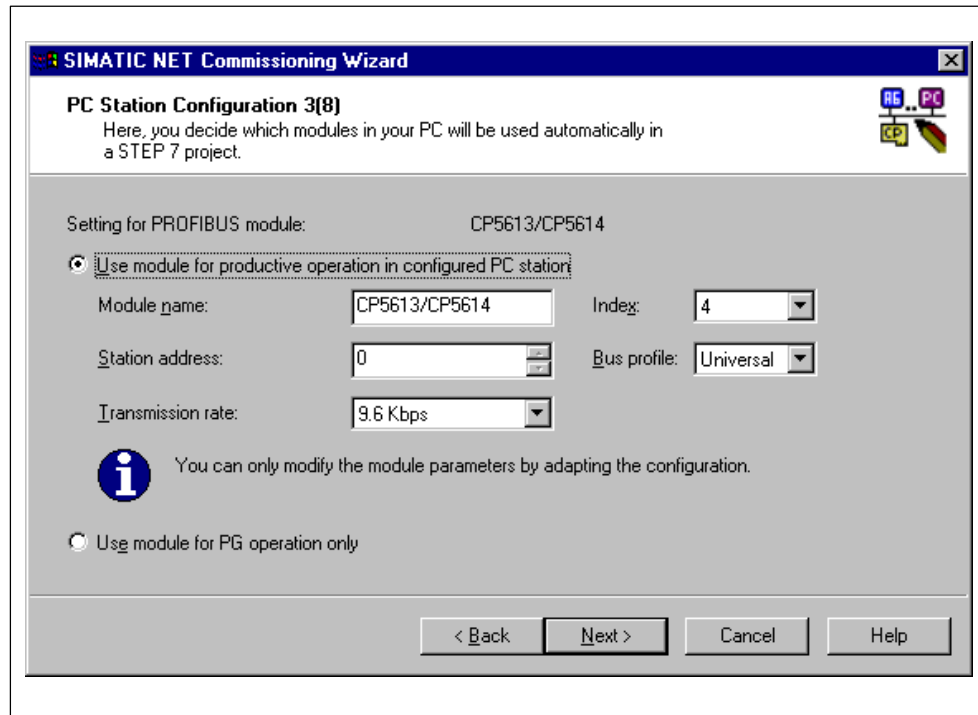

Figure 7-9 Commissioning wizard: settings for CP 5613

Result: You have then entered all the important settings.

4. Click “Next” or “Finish” as often as is necessary to quit the commissioning wizard.

7.4.4 Creating a Project

Perform the following steps:

1. Create a project called "Timesync".
2. Insert a PC station by entering **Insert > Station > SIMATIC PC Station** and calling the PC station "Box PC 620".
3. Insert a SIMATIC S7-400 station by entering **Insert > Station > SIMATIC 400 Station** and call the SIMATIC S7-400 station **S7-400**.

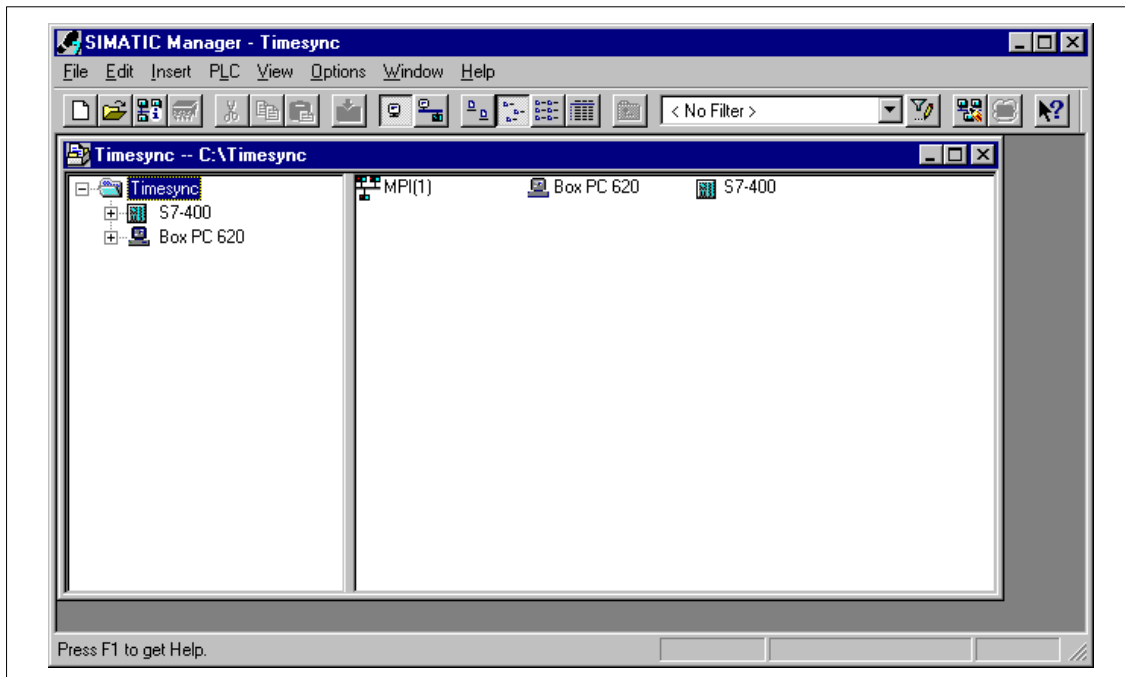

Figure 7-10 Creating a Project

Configuring the hardware of the PC 620 PC station

Selecting a mounting rack

1. Select Box PC 620.
2. Open “HWConfig” by double-clicking “Configuration”.
3. Open the catalog and branch to **SIMATIC PC Station > Controller > CPU 416-2 PCI > 6ES7 616-2QL00-0AB4 > V3.1.**
4. Drag and drop CPU 416-2 PCI onto slot 3.

Result: the “Properties – PROFIBUS Interfaces DP Master” dialog box opens.

5. Do not connect the subnet for the DP master.
6. Drag and drop CP 5613 into slot 4.
7. Connect the CP 5613 with the PROFIBUS network in NetPro.
8. Click “OK” to apply the settings.

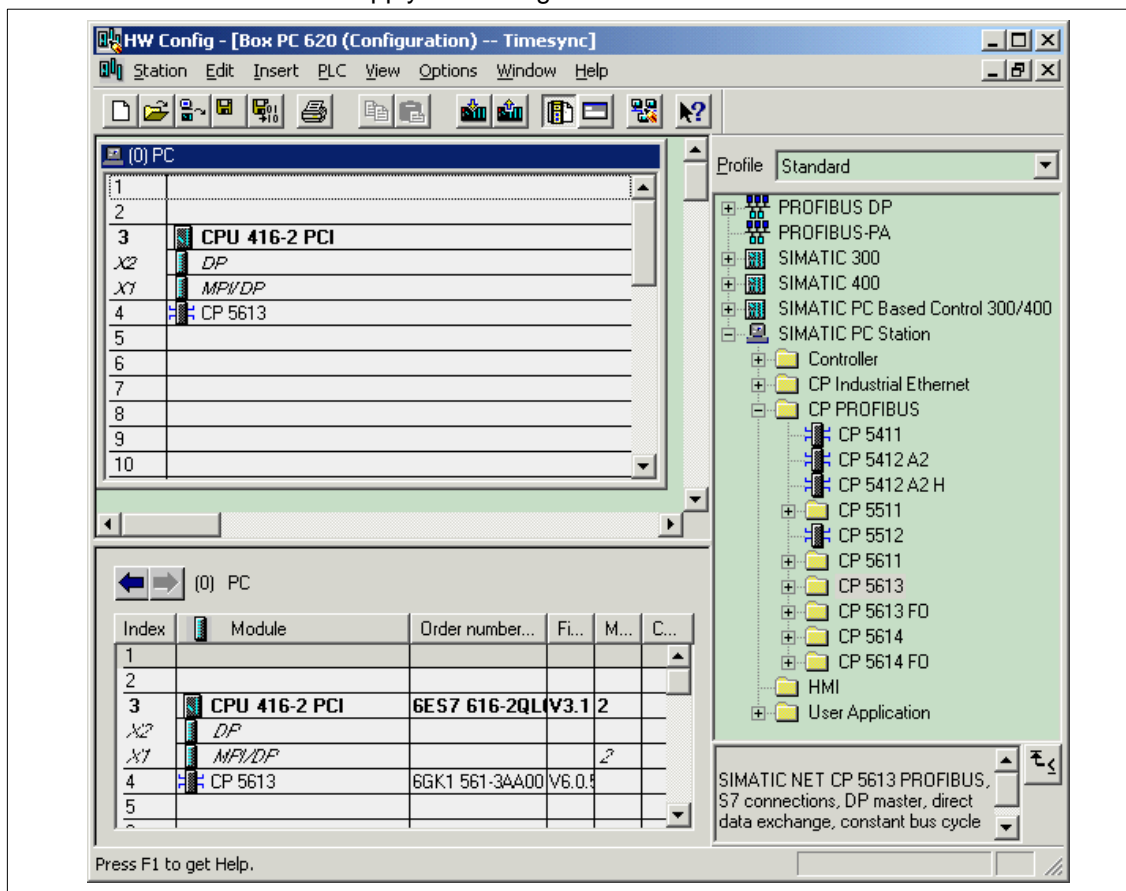

Figure 7-11 Selecting a Mounting Rack

9. Open the properties of the CP 5613 by double-clicking.
10. Go to the "Options" dialog box and set the clock synchronization as shown in the figure below:

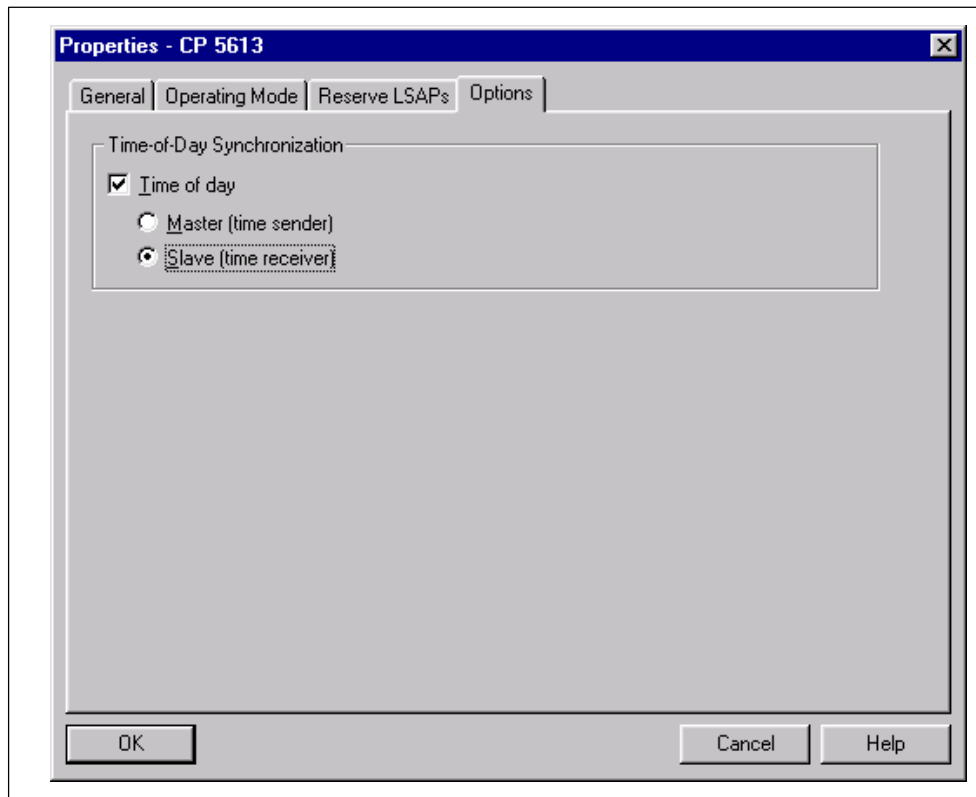

Figure 7-12 CP 5613: Properties

11. Confirm by clicking "OK".

Configuring the hardware of the S7-400 station

1. Select the components listed below and configure them as shown in Figure 7-13.
 - Rack
 - Power supply
 - CPU 416-1
 - CP 443-5 Basic
2. Do not connect the network for the CP 443–5 Basic.
3. Close with "Save and Compile".

Note

Note the current order number when making a selection.

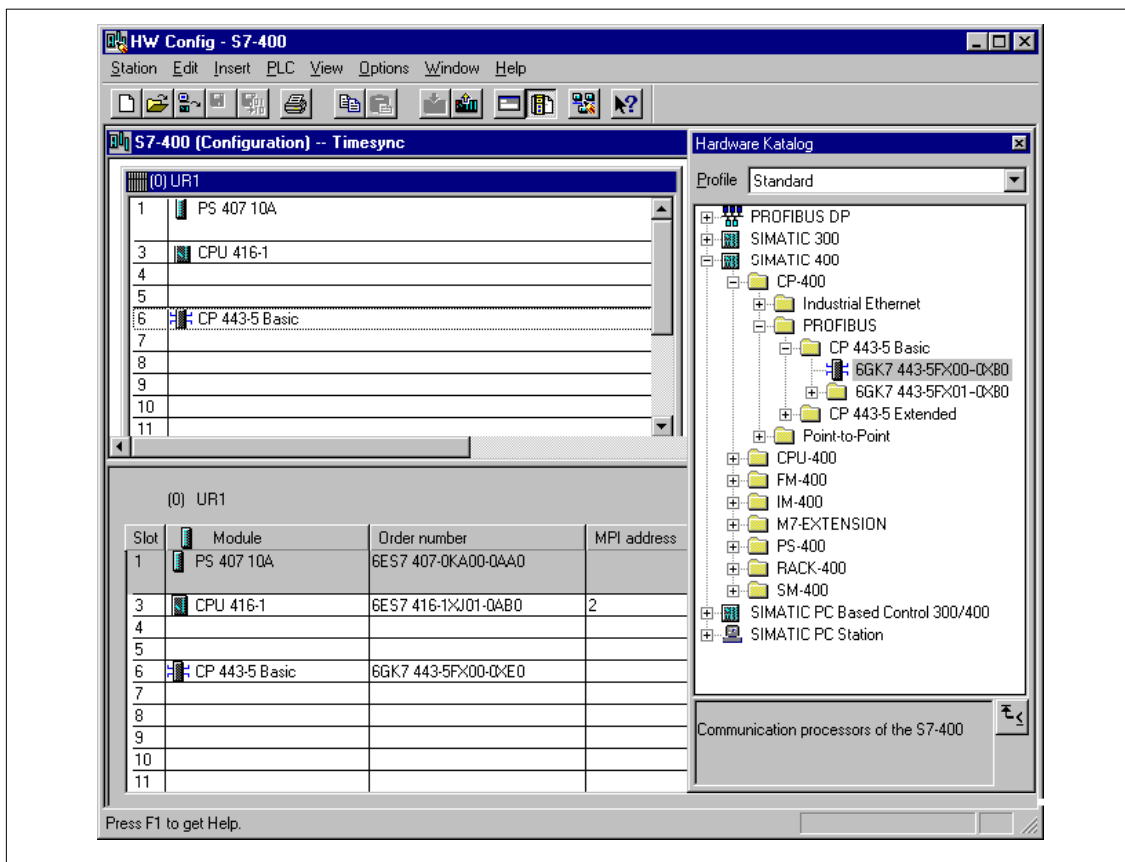

Figure 7-13 Configuring the Hardware of the S7-400 Station

Profibus connection

1. Select the project "Timesync".
2. Insert the PROFIBUS subnet by entering **Insert > Subnet > PROFIBUS** and changing the name of PROFIBUS to PB-Net.
3. Double-click PB-Net to open it.
4. Double-click the CP 443-5 Basic to select it.
5. Open the properties dialog, and select PB-Net.
6. Assign address "10".
7. Click "OK" to apply the settings.
8. Select the DP interface of the Box PC 620 by double-clicking.
9. Open the properties dialog, and select PB-Net.
10. Assign address "2".
11. Click "OK" to apply the settings.
12. Select the CP 5613 with a double-click.
13. Open the properties dialog and select PB-Net.
14. Assign the address "3".
15. Click "OK" to apply the settings.

Note

If the message "Bus profile DP not possible for module" is displayed, open the PB-Net by double-clicking and set the profile to the default on the Network Setting tab.

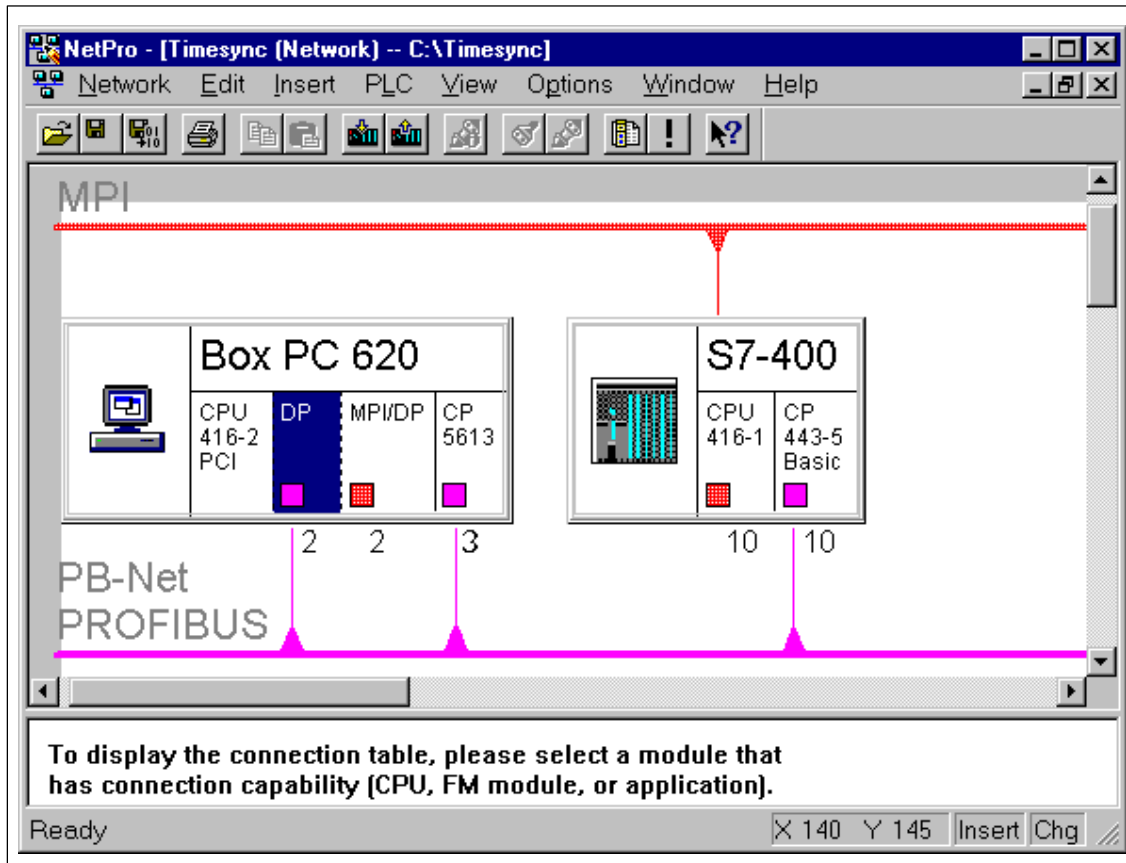

Figure 7-14 Bus Connection

Setting time synchronization

1. Double-click the CP443-5 to select it.
2. Open the "Options" tab.
3. Select the "Enable Time Synchronization" check box.
4. Click "OK" to apply your entry.

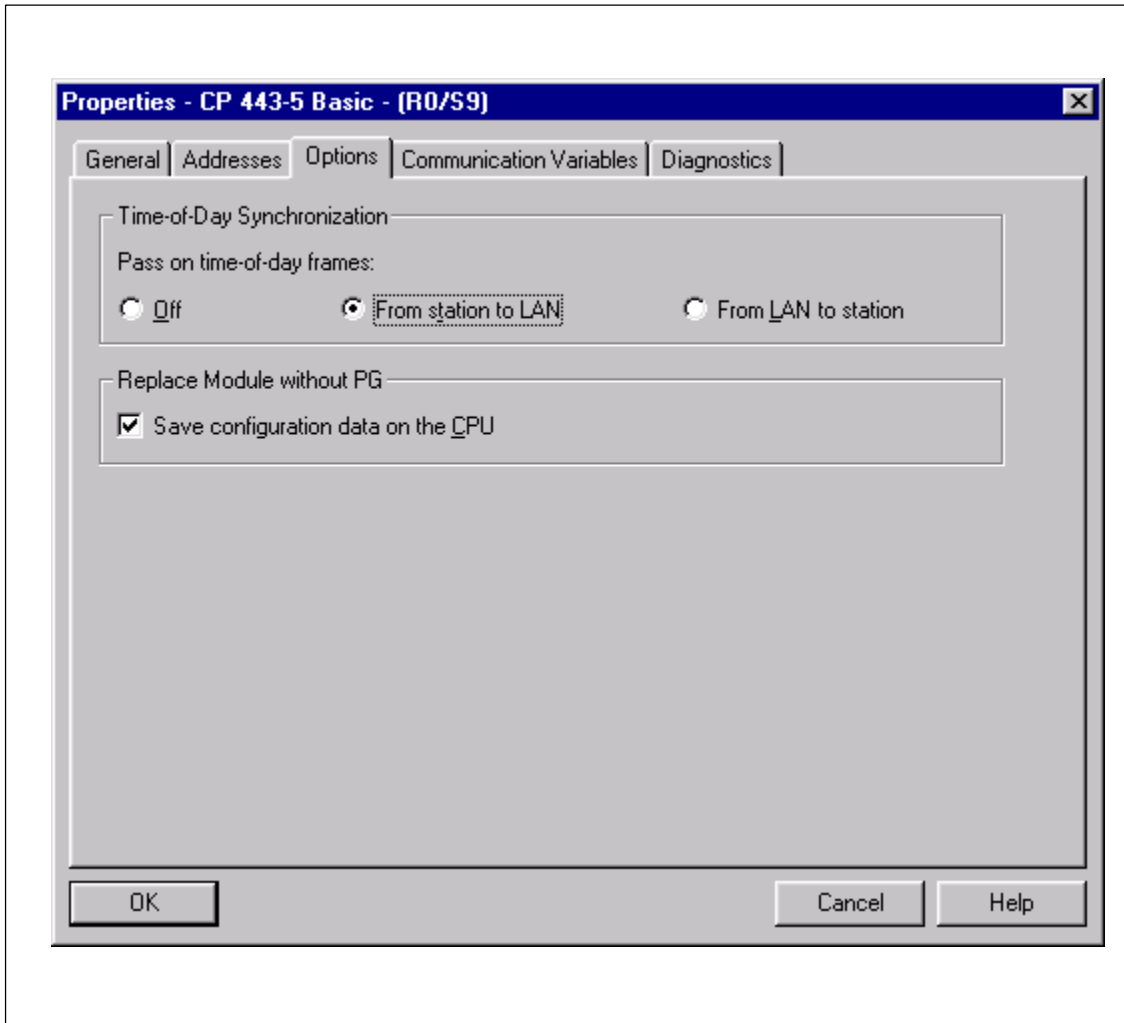

Figure 7-15 Enabling Time Synchronization

Setting a period

1. Double-click the CPU 416-1 to select it.
2. Open the "Diagnostics / Clock" tab.
3. Set the synchronization mode and the interval as shown in Figure 7-16.
4. Click "OK" to apply your entry.

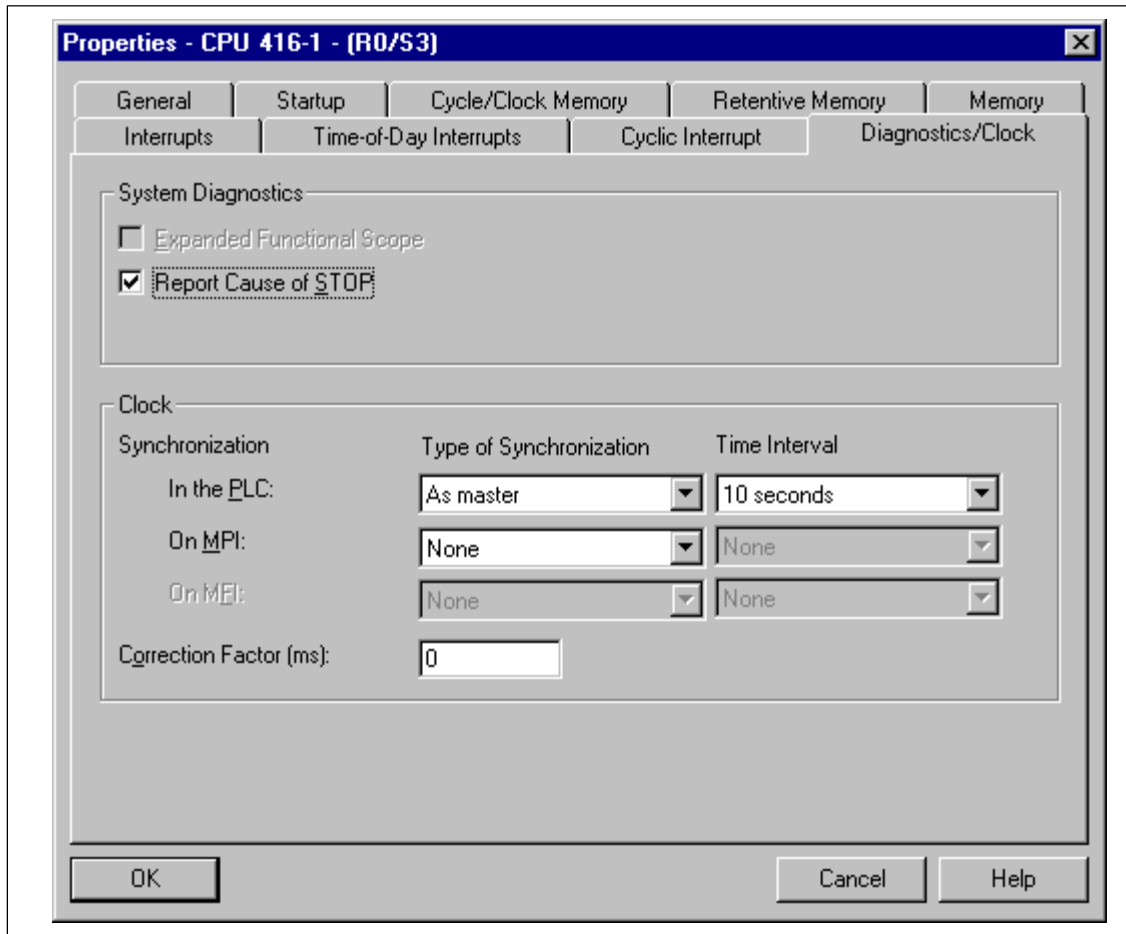

Figure 7-16 Setting a Period

Setting the synchronization mode

1. Double-click the CPU 416-2 PCI to select it.
2. Open the "Diagnostics / Clock" tab.
3. Set the synchronization mode as shown in Figure 7-17.
4. Click "OK" to apply your entry.

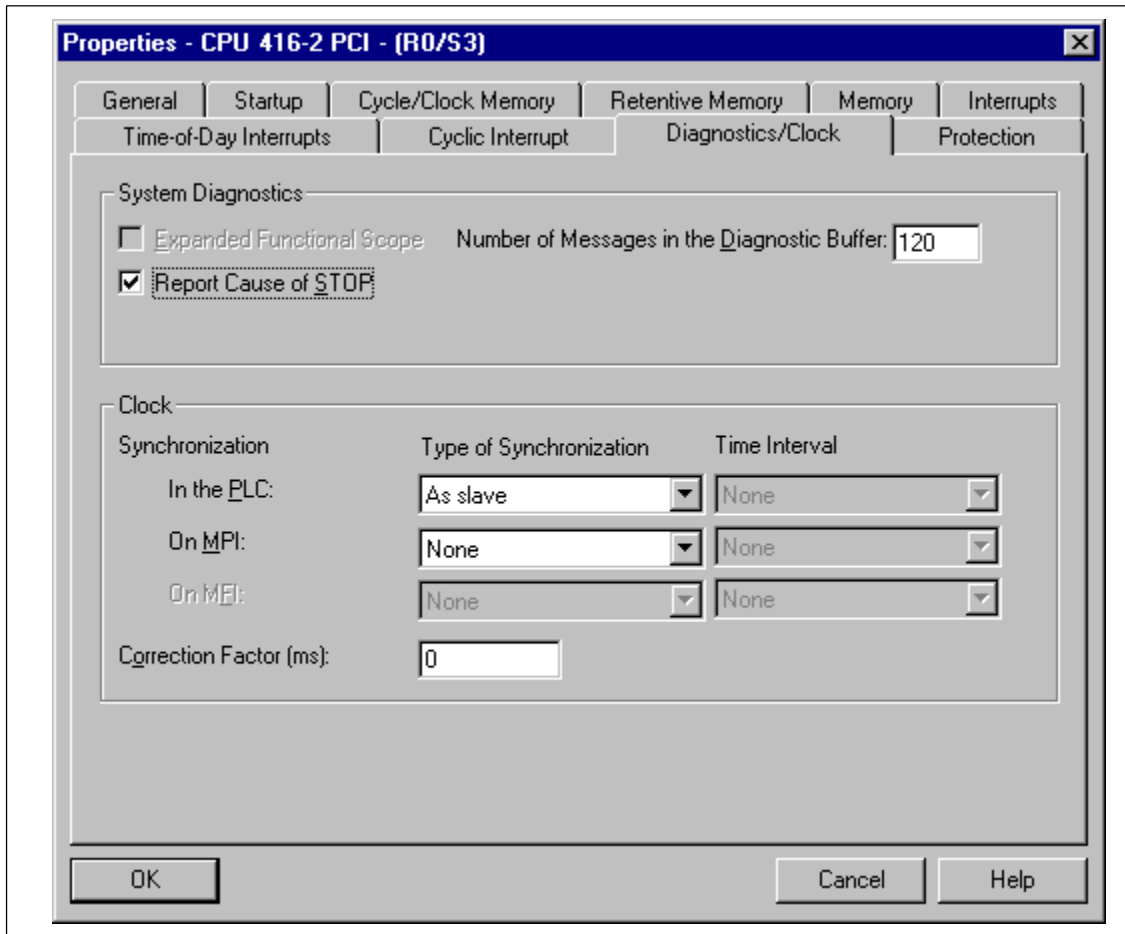

Figure 7-17 Setting the Synchronization Mode

These settings conclude the configuration of the "Timesync" project.

5. Load the data in the relevant stations.

7.4.5 Configuring an Access Point

1. Open the time synchronization by choosing the following from the taskbar:
Start > Simatic > PC Based Control > WinAC Time Synchronization
2. Click the "Set PG/PC Interface" button.
3. Select the CP "CP5613_5614(PROFIBUS)" from the "Interface Parameter Assignment Used" list box.

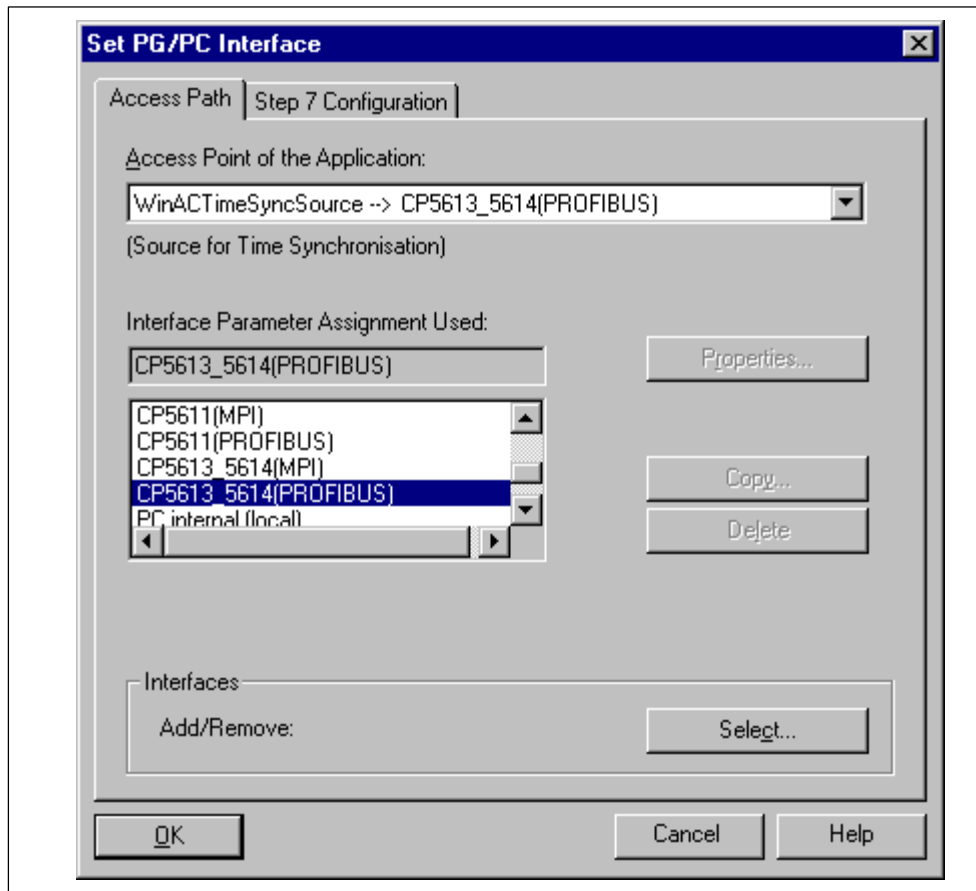

Figure 7-18 Setting the PG/PC Interface

4. Exit the "Set PG/PC Interface" program .

7.4.6 Starting Time Synchronization

Once you have configured the hardware, set the connections for the project and configured the access point, time synchronization can be carried out using the time-of-day synchronization facility.

1. Open the control panel of the time synchronization service from the task bar:
Start > Simatic > PC Based Control > WinAC Time Synchronization
2. Start time synchronization by clicking "Start".

CPU 412-2 PCI and CPU 416-2 PCI – Technical Specifications and Compatibility

8

In this chapter

| Section | Contents | Page |
|---------|--|------|
| 8.1 | Overview of the Parameters for the CPU 41x-2 PCI | 8-2 |
| 8.2 | Performance Features and Technical Specifications of the CPU 412-2 PCI | 8-3 |
| 8.3 | Performance Features and Technical Specifications of the CPU 416-2 PCI | 8-7 |
| 8.4 | Differences of CPU 41x-2 PCI from Previous Version (CPU 41x-2 PCI version 3.1) | 8-11 |

8.1 Overview of the Parameters for the CPU 41x-2 PCI

Introduction

Parameters can be assigned to properties and the response by the CPU. System data blocks incorporate parameter blocks that define the response of the operating system and internal CPU presets.

Default values

All parameters are set to their default values ex works. With these default values, which are suitable for a whole number of standard applications, the CPU 41x-2 PCI can be used directly and without additional settings.

Programmable system characteristics

The following list provides an overview of the programmable system characteristics available in the CPU 41x-2 PCI.

- General properties
- Startup
- Cycle/clock memory
- Retentive memory
- Local data
- Interrupts (hardware interrupts, time-delay interrupts, asynchronous error interrupts)
- Time-of-day interrupts
- Watchdog interrupts
- Diagnostics/clock

Parameter assignment tool

The different CPU parameters can be set in STEP 7 “Configure Hardware”.

8.2 Performance Features and Technical Specifications of the CPU 412-2 PCI

| CPU and Product Status | | Data areas and their retentivity | |
|---------------------------------------|---|---|--|
| MLFB | 6ES7 612-2QH00-0AB4 | Total retentive data area (incl. bit memory; timers; counters) | Total work and load memory (with backup battery) |
| • Hardware product status | 1 | Bit memories | 4 KB |
| • Firmware version | 3.1 | • Retentivity adjustable | from MB 0.0 to MB4095 |
| Associated programming package | STEP7 V 5.2 or higher | • Retentivity preset | from MB 0 to MB 15 |
| Memory | | Clock memories | 8 (1 memory byte) |
| Work memory | | Data blocks | max. 511 (DB0 reserved) |
| • Integrated | 128 KB for program 128 KB for data | • Size | max. 64 KB |
| • Expandable | no | Local data (adjustable) | max. 8 KB |
| Load memory | | • Default | 4 KB |
| • Integrated | 256 KB RAM | Blocks | |
| • Expandable FEPROM | with memory card (FLASH) up to 64 MB | OBs | refer to operation list |
| • Expandable RAM | with memory card (FLASH) up to 16 MB | • Size | max. 64 KB |
| Backup supply | yes | Nesting depth | |
| • With battery | all data | • Depending on priority class | 24 |
| • Without battery | none | • Additional classes within an error OB | 2 |
| Execution times | | FBs | max. 256 |
| Execution times for | | • Size | max. 64 KB |
| • Bit operations | min. 0.2 µs | FCs | max. 256 |
| • Word operations | min. 0.2 µs | • Size | max. 64 KB |
| • Fixed point arithmetic | min. 0.2 µs | Address areas (inputs/outputs) | |
| • Floating point arithmetic | min. 0.6 µs | Total address area | 4 KB/4 KB |
| Timers/counters and their retentivity | | • Of which distributed | |
| S7 counter | 256 | – MPI/DP interface | 2 KB/2 KB |
| • Retentivity adjustable | from C 0 to C 255 | – DP interface | 4 KB/4 KB |
| • Default | from C 0 to C 7 | Process image | 4 KB/4 KB (adjustable) |
| • Count range | 1 to 999 | The distributed I/O area is halved for every segment operated synchronous to 2x clock pulse, i.e. which is assigned an OB 61 ...64. | |
| IEC counter | yes | • Default | 128 byte/128 byte |
| • Type | SFB | • Number of partial process images | max. 8 |
| S7 timers | 256 | • Consistent data | max. 244 byte |
| • Retentivity adjustable | from T 0 to T 255 | Digital channels | 32768/32768 |
| • Default | no timers retentive | Analog channels | 2048/2048 |
| • Time range | 10 ms to 9990 s | | |
| IEC timer | yes | | |
| • Type | SFB | | |

| Configuration | | | |
|---|---|---|--|
| Multicomputing | no | Control system fault messages | yes |
| Number of DP masters | | Alarm-8 blocks | yes |
| • Integrated | 2 | • Number of entities for Alarm-8 blocks and blocks for S7 communication (adjustable) | max. 300 |
| Communication processors capable of operation | | • Default | 150 |
| • CP, PROFIBUS-DP | yes; only for communication link, not suitable for operation as DP master | Number of archive IDs that can be logged simultaneously | 8 |
| • CP, Industrial Ethernet | yes; only for communication link | Test and startup functions | |
| Time of day | | Status/Force Variable | yes |
| Real-time clock | yes | • Tags | inputs/outputs, bit memories, DB, I/Os, timers, counters |
| • Battery-backed | yes, only with battery backup | • Number of tags | max. 70 |
| • Resolution | 1 ms | Force | yes |
| • Accuracy during | | • Tags | inputs/outputs, bit memories, I/Os |
| – Power down | daily deviation 1.7 s | • Number | max. 64 |
| – Power up | daily deviation 8.6 s | Status block | yes |
| Operating hours counters | 8 | Single step | yes |
| • Number | 0 to 7 | Diagnostic buffer | yes |
| • Value Range | 0 to 32767 hours | • Number of entries | max. 400 (adjustable) |
| • Selectivity | 1 hour | • Default | 120 |
| • Retentive | yes | Communication functions | |
| Clock synchronization | yes | PG/OP communication | yes |
| • On AS | master/slave | Global data communication | yes |
| • On MPI | master/slave | • Number of GD circles | 8 |
| S7 message functions | | • Number of GD packages | |
| Number of stations that can be logged on for message functions (e. g. OS) | max. 8 | – Senders | max. 8 |
| SCAN procedure | yes | – Receivers | max. 16 |
| • Number of additional values per message | 1 | • Size of GD packages | max. 64 byte |
| – For 100 ms reference | none | – Of which consistent | 32 byte |
| – For 500, 1000 ms reference | 1 | S7 basic communication | yes |
| • Number of messages | | • Useful data per request | max. 76 byte |
| – Total | max. 512 | – Of which consistent | 16 byte |
| – 100 ms reference | none | S7 communication | yes |
| – 500 ms reference | max. 256 | • Useful data per request | max. 64 KB |
| – 1000 ms reference | max. 256 | – Of which consistent | 32 byte |
| Process diagnostic messages | yes | S5-compatible communication | no |
| • Alarm-S blocks active simultaneously | max. 70 | Number of connection resources | 16 |

| Interfaces | | DP slave | |
|--|--|---------------------------------|------------|
| Interface 1 | | Interface 2 | |
| Type of interface | integrated | Type of interface | Integrated |
| Physical level | RS 485 | Physical level | RS 485 |
| Optically isolated | yes | Optically isolated | yes |
| Power supply at interface (5 V) | max. 90 mA | Power supply at interface (5 V) | max. 90 mA |
| Number of connection resources | MPI: 16 DP: 16 | Number of connection resources | 16 |
| Functionality | | Functionality | |
| <ul style="list-style-type: none"> • MPI yes • PROFIBUS-DP DP master/DP slave • Supported DP protocol per interface DP-V1 and SI7 compatible, always depending on the other interface • Point-to-point link no | <ul style="list-style-type: none"> • MPI no • PROFIBUS-DP DP master/DP slave • Supported DP protocol per interface DP-V1 and SI7 compatible, always depending on the other interface • Point-to-point link no | | |
| MPI | | DP master | |
| <ul style="list-style-type: none"> • Services <ul style="list-style-type: none"> – PG/OP communication yes – Routing yes – Global data communication yes – S7 basic communication yes – S7 communication yes • Transmission speeds up to 12 Mbaud | <ul style="list-style-type: none"> • Services <ul style="list-style-type: none"> – PG/OP communication yes – Routing yes – Equidistance yes – SYNC/FREEZE yes – Enable/disable DP slaves yes • Transmission speeds up to 12 Mbaud • Number of DP slaves max. 64 • Address area max. 4 KB I / 4 KB O • Useful data per DP slave max. 244 byte I / 244 byte O | | |
| DP master | | DP slave | |
| <ul style="list-style-type: none"> • Services <ul style="list-style-type: none"> – PG/OP communication yes – Routing yes – Equidistance yes – SYNC/FREEZE yes – Enable/disable DP slaves yes • Transmission speeds up to 12 Mbaud • Number of DP slaves max. 32 • Address area max. 2 KB I / 2 KB O • Useful data per DP slave max. 244 byte I / 244 byte O | Data as for interface 1 | | |

| Interface 3 | | Dimensions | |
|---------------------------------------|-------------------------|--|-----------------------------|
| Type of interface | integrated | Mounting dimensions | 288×98×13.5 |
| Physical level | PCI | W×H×D (mm) | 3/4 length PCI plug-in card |
| Programming | | Slots required | 1 |
| Programming language | LAD, CSF, STL, SCL | Weight | approx. 250 g |
| Operation set | refer to operation list | Voltages, currents | |
| Bracket levels | 8 | Power supply | 5 V/12 V/24 V DC |
| System functions (SFCs) | refer to operation list | Current consumption | |
| Number of SFCs active simultaneously | | • Without PS extension board | |
| • WR_REC | 8 | – from PCI bus (5 V DC) | max. 1.5 A |
| • WR_PARM | 8 | • With PS extension board | |
| • PARM_MOD | 1 | – from PCI bus (5 V DC) | max. 0.3 A |
| • WR_DPARAM | 2 | – from power supply unit (12 V DC/24 V) (int./ext.) | max. 1.2 A |
| • DPNRM_DG | 8 | | |
| • RDSYSST | 1 to 8 | Backup current from ext. 3.6 V battery of PS extension board | typ. 130 µA max. 500 µA |
| System functions blocks (SFBs) | refer to operation list | Incoming supply of external backup voltage to CPU | 5 to 15 V DC |
| Number of active SFBs simultaneously | | Power losses | typ. 12 W |
| • RD_REC | 8 | | |
| • R_ALARM | 8 | | |
| User program protection | password protection | | |
| Clock synchronicity | | | |
| User data per clock synchronous slave | max.128 bytes | | |
| PG/OP communication | yes | | |
| Routing | yes | | |
| Åquidistant | yes | | |
| Shortest pulse | 5 ms | | |

8.3 Performance Features and Technical Specifications of the CPU 416-2 PCI

| CPU and Product Status | | Data areas and their retentivity | |
|---------------------------------------|---------------------------------------|--|--|
| MLFB | 6ES7 616-2QL00-0AB4 | Total retentive data area (incl. bit memory; timers; counters) | Total work and load memory (with backup battery) |
| • Hardware product status | 1 | Memory markers | 16 KB |
| • Firmware version | 3.1 | • Retentivity adjustable | from MB 0 to MB 16383 |
| Associated programming package | STEP7 v.5.1 or higher; Service Pack 2 | • Retentivity preset | from MB 0 to MB 15 |
| Memory | | Clock memories | 8 (1 memory byte) |
| Work memory | | Data blocks | max. 4095 (DB0 reserved) |
| • Integrated | 1.6 MB for program 1.6 MB for data | • Size | max. 64 KB |
| • Expandable | no | Local data (adjustable) | max. 32 KB |
| Load memory | | • Default | 16 KB |
| • Integrated | 256 KB RAM | Blocks | |
| • Expandable FEPROM | with memory card (FLASH) up to 64 MB | OBs | refer to operation list |
| • Expandable RAM | with memory card (FLASH) up to 16 MB | • Size | max. 64 KB |
| Backup supply | yes | Nesting depth | |
| • With battery | all data | • Depending on priority class | 24 |
| • Without battery | none | • Additional classes within an error OB | 2 |
| Execution times | | FBs | max. 2048 |
| Execution times for | | • Size | max. 64 KB |
| • Bit operations | min. 0.08 µs | FCs | max. 2048 |
| • Word operations | min. 0.08 µs | • Size | max. 64 KB |
| • Fixed point arithmetic | min. 0.08 µs | Address areas (inputs/outputs) | |
| • Floating point arithmetic | min. 0.48 µs | Total address area | 16 KB/16 KB |
| Timers/counters and their retentivity | | • Of which distributed | |
| S7 counter | 512 | – MPI/DP interface | 2 KB/2 KB |
| • Retentivity adjustable | from C 0 to C 511 | – DP interface | 8 KB/8 KB |
| • Default | from C 0 to C 7 | The distributed I/O area is halved for every segment operated synchronous to the clock pulse, i.e. which is assigned an OB 61 ...64. | |
| • Count range | 1 to 999 | Process image | 16 KB/16 KB (adjustable) |
| IEC counter | yes | • Default | 512 byte/512 byte |
| • Type | SFB | • Number of partial process images | max. 8 |
| S7 timers | 512 | Digital channels | 131072/131072 |
| • Retentivity adjustable | from T 0 to T 511 | Analog channels | 8192/8192 |
| • Default | no timers retentive | | |
| • Time range | 10 ms to 9990 s | | |
| IEC timer | yes | | |
| • Type | SFB | | |

| Configuration | |
|--|---|
| Multicomputing | no |
| Number of DP masters | |
| • Integrated | 2 |
| Communication processors capable of operation | |
| • CP, PROFIBUS-DP | yes; only for communication link, not suitable for operation as DP master |
| • CP, Industrial Ethernet | yes; only for communication link |
| Time of day | |
| Real-time clock | yes |
| • Battery-backed | yes, only with backup battery |
| • Resolution | 1 ms |
| • Accuracy during | |
| – Power down | daily deviation 1.7 s |
| – Power up | daily deviation 8.6 s |
| Operating hours counters | 8 |
| • Number | 0 to 7 |
| • Value Range | 0 to 32767 hours |
| • Selectivity | 1 hour |
| • Retentive | yes |
| Clock synchronization | yes |
| • On AS | master/slave |
| • On MPI | master/slave |
| S7 message functions | |
| Number of stations that can be logged on for message functions (e. g. OS) | max. 12 |
| SCAN procedure | yes |
| • Number of additional values per message | 1 |
| – For 100 ms reference | none |
| – For 500, 1000 ms reference | 10 |
| • Number of messages | |
| – Total | max. 1024 |
| – 100 ms reference | 128 |
| – 500 ms reference | max. 512 |
| – 1000 ms reference | max. 1024 |
| Process diagnostic messages | yes |
| • Alarm-S blocks active simultaneously | max. 200 |
| Control system fault messages | yes |
| Alarm-8 blocks | yes |
| • Number of entities for Alarm-8 blocks and blocks for S7 communication (adjustable) | max. 1800 |
| • Default | 600 |
| Number of archive IDs that can be logged simultaneously | 32 |
| Test and startup functions | |
| Status/Force Variable | yes |
| • Tags | inputs/outputs, bit memories, DB, I/Os, timers, counters |
| • Number of tags | max. 70 |
| Force | yes |
| • Tags | inputs/outputs, bit memories, I/Os |
| • Number | max. 512 |
| Status block | yes |
| Single step | yes |
| Diagnostic buffer | yes |
| • Number of entries | max. 3200 (adjustable) |
| • Default | 120 |
| Communication functions | |
| PG/OP communication | yes |
| Global data communication | yes |
| • Number of GD circles | 16 |
| • Number of GD packages | |
| – Senders | max. 16 |
| – Receivers | max. 32 |
| • Size of GD packages | max. 64 byte |
| – Of which consistent | 32 byte |
| S7 basic communication | yes |
| • Useful data per request | max. 76 byte |
| – Of which consistent | 16 byte |
| S7 communication | yes |
| • Useful data per request | max. 64 KB |
| – Of which consistent | 32 byte |
| S5-compatible communication | no |
| Number of connection resources | 64 |

| Interfaces | | DP slave | |
|---|--|---|---|
| Interface 1 | | Interface 2 | |
| Type of interface | integrated | Type of interface | integrated |
| Physical level | RS 485 | Physical level | RS 485 |
| Optically isolated | yes | Optically isolated | yes |
| Power supply at interface (5 V) | max. 90 mA | Power supply at interface (5 V) | max. 90 mA |
| Number of connection resources | MPI: 44 DP: 32 | Number of connection resources | 32 |
| Functionality | | Functionality | |
| <ul style="list-style-type: none"> • MPI • PROFIBUS-DP • Supported DP protocol per interface • Point-to-point link | yes DP master/DP slave DP-V1 and SI7 compatible, always depending on the other interface no | <ul style="list-style-type: none"> • MPI • PROFIBUS-DP • Supported DP protocol per interface • Point-to-point link | no DP master/DP slave DP-V1 and SI7 compatible, always depending on the other interface no |
| MPI | | DP master | |
| <ul style="list-style-type: none"> • Services <ul style="list-style-type: none"> – PG/OP communication – Routing – Global data communication – S7 basic communication – S7 communication • Transmission speeds | yes yes yes yes yes up to 12 Mbaud | <ul style="list-style-type: none"> • Services <ul style="list-style-type: none"> – PG/OP communication – Routing – Equidistance – SYNC/FREEZE – Enable/disable DP slaves • Transmission speeds • Number of DP slaves • Address area • Useful data per DP slave | yes yes yes yes yes up to 12 Mbaud max. 125 max. 8 KB I / 8 KB O max. 244 byte I / 244 byte O |
| DP master | | DP slave | |
| <ul style="list-style-type: none"> • Services <ul style="list-style-type: none"> – PG/OP communication – Routing – Equidistance – SYNC/FREEZE – Enable/disable DP slaves • Transmission speeds • Number of DP slaves • Address area • Useful data per DP slave | yes yes yes yes yes up to 12 Mbaud max. 32 max. 2 KB I / 2 KB O max. 244 byte I / 244 byte O | Data as for interface 1 | |

| Interface 3 | | Dimensions | |
|---------------------------------------|-----------------------------------|--|-----------------------------|
| Type of interface | integrated | Mounting dimensions | 288×98×13.5 |
| Physical level | PCI | W×H×D (mm) | 3/4 length PCI plug-in card |
| Programming | | Slots required | 1 |
| Programming language | LAD, CSF, STL, SCL | Weight | Approx. 250 g |
| Operation set | refer to operation list | Voltages, currents | |
| Bracket levels | 8 | Power supply | 24 V DC/ 12 V / 24 V |
| System functions (SFCs) | refer to operation list | Current consumption | |
| Number of SFCs active simultaneously | | • Without PS extension board | |
| • WR_REC | 8 | – from PCI bus (5 V DC) | max. 1.5 A |
| • WR_PARM | 8 | • With PS extension board | |
| • PARM_MOD | 1 | – from PCI bus (5 V DC) | max. 0.3 A |
| • WR_DPARM | 2 | – from power supply unit (12 V DC/24 V) (int./ext.) | max. 1.2 A |
| • DPNRM_DG | 8 | | |
| • RDSYSST | 1 to 8 | Backup current from ext. 3.6 V battery of PS extension board | typ. 130 µA max. 500 µA |
| System functions blocks (SFBs) | refer to operation list | Incoming supply of external backup voltage to CPU | 5 to 15 V DC |
| Number of active SFBs simultaneously | | Power losses | typ. 12 W |
| • RD_REC | 8 | | |
| • R_ALARM | 8 | | |
| User program protection | password protection | | |
| Clock synchronicity | | | |
| User data per clock synchronous slave | max.128 bytes | | |
| PG/OP communication | yes | | |
| Routing | yes | | |
| Äquidistant | yes | | |
| Shortest pulse | 5 ms | | |
| shortest Takt | 5 ms | | |
| | 2.5 ms without using SFC 126, 127 | | |

8.4 Differences of CPU 41x-2 PCI from Previous Version (CPU 41x-2 PCI Version 3.2)

You will find a list of changes compared to CPU 41x-2 PCI V3.2 in the following:

- You can also operate CPU 41x-2 PCI under Windows XP Professional with SP1 or later
- Windows NT SP 4 is no longer supported.
- Using SFC 126 “SYNC_PI” and SFC 127 “SYNC_PO” you can update process image partitions synchronous to the DP clock.
- Using SFC 103 “DP_TOPOL” you can determine the bus topology of a DP master system by triggering the diagnostics repeater.

Reserved address area for a technological application



Caution

In version 3.2 or higher: in the CPU 412-2 PCI, the PEW 4096 to 8190 and PAW 4096 to 8190 – in the CPU 416-2 PCI the PEW 16384 to 20478 and PAW 16384 to 20478 – are reserved for a technological application.

If you access the above address area in your STEP 7 user program, an I/O access error is not generated, irrespective of whether or not a technological function is being operated in this area.

Changing from CPU 41x-2 PCI to CPU 41x-2 PCI version 3.3

You can use all the STEP 7 user programs (version 4.01 or higher) you wrote for the CPU PCI version 3.2 in conjunction with version 3.3. That means STEP 7 user programs for

- CPU 412-2 PCI/ version 3.2 run on the CPU 412-2 PCI version 3.3 and on the CPU 416-2 PCI version 3.3,
- and
- CPU 416-2 PCI version 3.1 on the CPU 416-2 PCI version 3.2

You can also use memory cards with STEP 7 user programs for CPUs 41x-2 PCI.

The following applies here again:

- Memory cards of the CPU 412-2 PCI version 3.2 run on the CPU 412-2 PCI version 3.3 and on the CPU 416-2 PCI version 3.3.
- and
- Memory cards of the CPU 416-2 PCI version 3.2 run on the CPU 416-2 PCI version 3.3.

Uploading a FLASH Card from CPU to STEP 7/Configure Hardware

You can upload a STEP 7 user program by inserting a FLASH card from an old CPU 41x-2 PCI version 3.2 into a new CPU 41x-2 PCI version 3.3.

Downloading a configuration to a RAM card with STEP 7/Configure Hardware

You can download a STEP 7 user program that you wrote for a CPU 41x-2 PCI version 3.2 onto a new CPU 41x-2 PCI version 3.3.

PS Extension Board

Order No.

6ES7 678-1RA00-0XB0

The PS extension board can be ordered separately.

Function

The PS extension board (PS: power supply) is used to supply voltage to the CPU 41x-2 PCI independently of the PC power supply unit. In this way it is possible to operate the CPU 41x-2 PCI even when the PC has been powered down.

By connecting the backup battery, warm restart (restart) and complete restart are possible for the CPU 41x-2 PCI.

In addition, you operate the fan on the PC with the PS extension board.

The PS extension board (PS: power supply) provides the CPU 41x-2 PCI on the PC with the following voltages:

- 5 V DC for supplying the CPU 41x-2 PCI
- 12 V DC for supplying the fan on the PC
- Battery voltage for backup supply

You will find further information on installing and connecting the PS extension board in Chapter 2.

Appearance

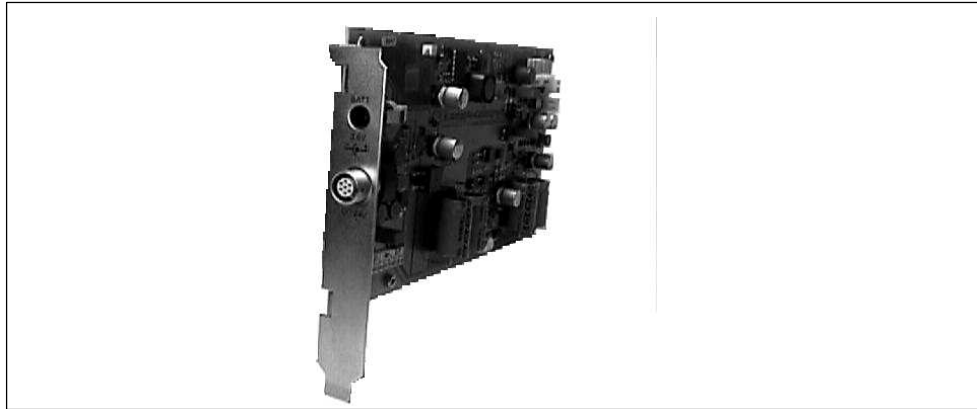

Figure 9-1 PS Extension Board

Technical specifications

| Dimensions, weight and cable cross-sections | | Output variables | |
|--|--|--|---|
| Dimensions W × H × D (mm) | 180 × 98 × 13.5 | Output voltages | |
| Weight | 150 g | <ul style="list-style-type: none"> Rated value Permissible Range | 5.1 V DC/12 V DC 5.1 V DC ± 3 % 12 V DC ± 5 % |
| Input variables | | Output currents | |
| Input voltage 24 V DC | safely isolated extra-low voltage; SELV | <ul style="list-style-type: none"> Rated values | to CPU: 5.1 V DC/1.5 A to PC fan: 12 V DC: 0.4 A |
| <ul style="list-style-type: none"> Rated value Permissible range | 24V DC static: 19.2 to 28.8 V dynamic: 18.5 to 30.2 V | Max. residual ripple | 5.1 V DC: 50 mV _{p-p} DC 12 V: 200 mV _{p-p} |
| Input voltage 12 V DC | from PC power supply unit | Max. switching peaks | 5.1 V DC: 150 mV _p DC 12 V: 500 mV _p |
| <ul style="list-style-type: none"> Rated value Permissible Range | 12 V DC static: 11.9 to 12.4 V dynamic: 11.4 to 12.6 V | No-load conditions | 5.1 V DC: stable at no load 12 V DC: stable at no load (no basic load necessary) |
| Input voltage 3.6 V DC | external backup battery | Fan connection | max. 300 mA at 12 V |
| <ul style="list-style-type: none"> Rated value Permissible range | 3.6 V DC 3.4 V to 3.95 V (temperature-dependent) | Performance characteristics | |
| Input rated current | 1 A | Safety class to IEC 536 | I, with protective conductor |
| Starting current inrush | peak value 15 A half width of peak 10 ms | Bridging of power failures | 15 ms |
| Overvoltage withstand capability | To DIN VDE 0160, curve B2 | Power consumption | 24 W from external 24 V DC incoming supply |
| | | Power losses | 3 W |
| | | Buffer current | typ. 130 μA max. 500 μA upon POWER DOWN |
| | | Backup battery (option) | 1 × Lithium AA, 3.6 V/1.9 Ah |

10

Memory Cards

In this chapter

| Section | Contents | Page |
|---------|-----------------------|------|
| 10.1 | Design and Function | 10-1 |
| 10.2 | Types of Memory Cards | 10-2 |

10.1 Design and Function

Design

A memory card is somewhat larger than a smart card and protected by a rugged metal housing. It is plugged into a slot on the CPU; the direction in which it is inserted is determined by the design of the memory card.

Figure 10-1 illustrates the design of a memory card.

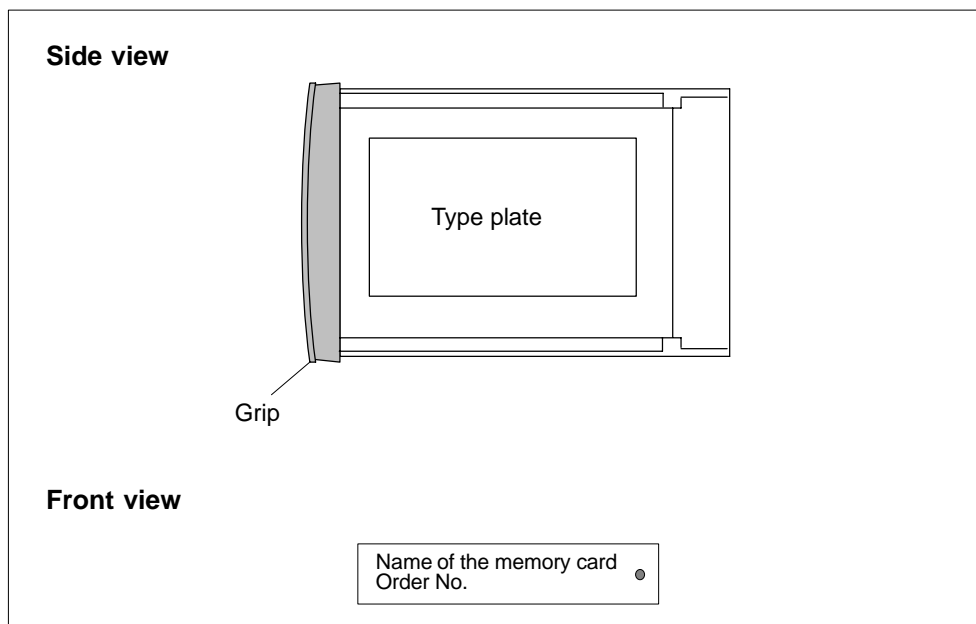

Figure 10-1 Memory Card

Function

The memory card and an integrated memory area on the CPU motherboard together form the load memory of the CPU. During operation, the load memory can contain the entire user program, including the comments, symbols and specific additional information that allows uncompiling of the user program, and all module parameters.

In order to make full use of the CPU memory, you should insert a memory card having a capacity higher than that of the CPU work memory.

What is stored on the memory card?

You can store the following data on the memory card:

- user program – in other words, blocks (OBs, FBs, FCs, DBs)
- parameters determining the response of the CPU
- parameters determining the response of the I/O modules

10.2 Types of Memory Cards

You can insert two types of memory cards:

- RAM card or
- FLASH card (FEPROM card)



Caution

Memory cards that are not compatible with the system must not be inserted in the CPU 41x-2 PCI.

What type of memory card should you use?

Whether you use a RAM card or a FLASH card depends on how you want to use the memory card.

| If ... | Then ... |
|---|-------------------------|
| You store the data in RAM and want to change your program even during RUN-P mode. | Use a RAM card |
| You want to save you user program permanently even in a de-energized state (without battery backup or external to the CPU). | Use a FLASH card |

Table 10-1 Differences Between RAM Card and FLASH Card

| RAM Card | FLASH Card |
|--|---|
| <p>The RAM card must be plugged into the CPU to load the user program. The user program is loaded with the help of the programming device (PG).</p> | <p>There are two ways in which you can load the user program:</p> <ul style="list-style-type: none"> • You set the CPU to STOP with the mode switch, plug the FLASH card into the CPU and load the user program into the load memory with the assistance of the programming device (PG). • You load the user program in Offline mode on the programming device into the FLASH card and then plug the FLASH card into the CPU. |
| <p>You can load the complete user program or individual parts, such as FBs, FCs, OBs, DBs or SDBs, into the load memory in STOP or RUN-P mode.</p> | <p>You can reload your complete user program. You can reload smallish program sections with the PG into the load memory integrated on the CPU. With largish program changes, you must always reload the FLASH card with the complete user program.</p> |
| <p>If you remove the RAM card from the CPU, the information stored on it will be lost. In addition, the CPU prompts you to perform a memory reset. The RAM card does not have an integrated backup battery.</p> <p>If an external backup voltage is fed into the "BATT." socket on the PS extension board, the memory contents of the RAM card are retained after the PC has been turned off or as long as the RAM card is plugged into the CPU.</p> | <p>The FLASH card does not need voltage to store its contents – in other words, the information it contains is retained if you remove the FLASH card from the CPU or operate your system without a backup battery (without external backup voltage at the "BATT." socket of the PS extension board).</p> |

What memory card capacity should you use?

The capacity of the memory card you use depends on the scope of the user program and the additional memory requirement resulting from the use of function modules and communication processors. You can estimate their memory requirements in STEP 7.

Changing a memory card



Warning

The memory card can only be removed and plugged in when the PC is open. You can also change the memory card while the CPU 41x-2 PCI is operating.

Replacement of the memory card while the CPU 41x-2 PCI is operating is allowed only when the manufacturer of the PC authorizes the PC to be opened while the PC is energized.

Make sure you do not touch any live parts when a PC is open!

You can replace the memory card in a de-energized state or while the CPU 41x-2 PCI is operating.

To change the memory card, perform the following steps:

1. Click the STOP option button.
2. Extract the inserted memory card.
3. Plug the memory card into the slot on the CPU and push the memory card home into the slot – in other words, as far as the stop.

Result: the CPU prompts you to perform a memory reset by the STOP indication flashing slowly at 0.5 Hz.

4. Click the MRES option button.

Result: the STOP indication flashes for at least 3 seconds at 2 Hz (a memory reset is performed) and then changes to being permanently on.

Technical specifications

| Dimensions W×H×D (in mm) | 7.5 × 57 × 87 | | | |
|------------------------------|---------------------------------|--------|-----------------|-------|
| Weight | max. 35 g | | | |
| EMC protection | incorporated by design measures | | | |
| Data specific to memory card | | | | |
| Name | Current consumption at 5 V | | Buffer currents | |
| | Typically | Max. | Typically | Max. |
| MC 952 / 64 KB / RAM | 20 mA | 50 mA | 0.5 µA | 20 µA |
| MC 952 / 256 KB / RAM | 35 mA | 80 mA | 1 µA | 40 µA |
| MC 952 / 1 MB / RAM | 40 mA | 90 mA | 3 µA | 50 µA |
| MC 952 / 2 MB / RAM | 45 mA | 100 mA | 5 µA | 60 µA |
| MC 952 / 4 MB / RAM | 45 mA | 100 mA | 5 µA | 60 µA |
| MC 952 / 8 MB / RAM | 45 mA | 100 mA | 5 µA | 60 µA |
| MC 952 / 16 MB / RAM | 45 mA | 100 mA | 5 µA | 60 µA |
| MC 952 / 64 KB / 5V FLASH | 15 mA | 35 mA | – | – |
| MC 952 / 256 KB / 5V FLASH | 20 mA | 45 mA | – | – |
| MC 952 / 1 MB / 5V FLASH | 40 mA | 90 mA | – | – |
| MC 952 / 2 MB / 5V FLASH | 50 mA | 100 mA | – | – |
| MC 952 / 4 MB / 5V FLASH | 40 mA | 90 mA | – | – |
| MC 952 / 8 MB / 5V FLASH | 50 mA | 100 mA | – | – |
| MC 952 / 16 MB / 5V FLASH | 55 mA | 110 mA | – | – |
| MC 952 / 32 MB / 5V FLASH | 55 mA | 110 mA | – | – |
| MC 952 / 64 MB / 5V FLASH | 55 mA | 110 mA | – | – |

General Technical Specifications

A

What are general technical specifications?

The general technical specifications contain the standards and test values with which the CPU 41x-2 PCI and the PS extension board comply and meet, as well as the test criteria to which the modules were tested.

In this chapter

This appendix contains the following topics concerning general technical specifications:

| Section | Contents | Page |
|---------|--|------|
| A.1 | Standards, Certificates and Approvals | A-1 |
| A.2 | Electromagnetic Compatibility | A-3 |
| A.3 | Shipping and Storage Conditions | A-4 |
| A.4 | Mechanical and Climatic Environmental Conditions | A-6 |
| A.5 | Certification for USA, Canada and Australia | A-8 |

A.1 Standards, Certificates and Approvals

Introduction

This section contains details of

- the most important standards with whose criteria the modules comply, and
- approvals for the modules.

CE mark

Our modules meet the requirements of EC Directive 89/336/EEC, "Electromagnetic Compatibility" (EMC Directive).

The declarations of conformity are held at the address below, where they can be obtained if and when required by the respective authorities:

Siemens Aktiengesellschaft
Automation Group
A&D AS E 42
P.O. Box 1963
D-92209 Amberg
Federal Republic of Germany

Area of application

SIMATIC products have been designed for use in an industrial environment.

| Area of application | Requirements for | |
|--|----------------------|-------------------|
| | Emitted interference | Immunity |
| Domestic, business and commercial, and small companies | EN 50081-1: 1992 | EN 50082-1: 1992 |
| Industry | EN 50081-2 : 1993 | EN 50082-2 : 1995 |

Test environment

All technical specifications were demonstrated in a SIMATIC Box PC 620 test environment.

UL approval

UL Recognition Mark
Underwriters Laboratories (UL) to Standard UL 1950, Report E 115352

CSA approval

CSA Certification Mark
Canadian Standard Association (CSA) to Standard C 22.2 No. 950,
Report D81690C000

A.2 Electromagnetic Compatibility

Definition

All the components of the CPU 41x-2 PCI and the PS extension board meet the requirements of the applicable European standards when configured in accordance with the relevant regulations.

The modules have been tested in a device that likewise conforms to the standards listed below. If the modules are operated in a device that does not meet these standards, compliance with the corresponding values cannot be guaranteed.

You will find details below relating to noise immunity and radio interference suppression details.

Pulse-shaped disturbance variables

The following table shows the electromagnetic compatibility of the modules in respect of pulse-shaped disturbance variables. This presupposes that the system corresponds to the specifications and guidelines on electrical design.

| Pulse-shaped disturbance variable | Tested with | Corresponds to severity |
|--|--|-------------------------|
| Electrostatic discharge to IEC 61000-4-2 | Discharge in air: ± 8 kV Contact discharge: ± 6 kV | 3 |
| Burst pulses (rapid transient disturbance variables) to 61000-4-4 | 2 kV | 3 |
| High-energy surge to IEC 61000-4-5 <ul style="list-style-type: none"> • Asymmetrical cross coupling • Symmetrical cross coupling | 2 kV (supply line) DC voltage with protective elements 1 kV (supply line) DC voltage with protective elements | 3 |

Sinusoidal disturbance variables

The following table shows EMC behavior in respect of sinusoidal disturbance variables:

| Sinusoidal disturbance variable | Tested with | Corresponds to severity |
|---|---|-------------------------|
| RF irradiation (radiated electromagnetic field test) to IEC 61000-4-3 | 10 V/m with 80% amplitude modulation of 1 kHz over a range from 80 MHz to 1000 MHz 10 V/m with 50% pulse modulation at 900 MHz | 3 |
| RF current application on lines and line screens to IEC 61000-4-6 | Test voltage 10 V/m with 80% amplitude modulation of 1 kHz over a range from 9 kHz to 80 MHz | 3 |

Emission of radio interference

Radio interference suppression to EN 55022: limit value class B.

Working with the product

To protect the product from the electrostatic discharge, operating personnel must take appropriate action to discharge their bodies before coming into contact with the module.

A.3 Shipping and Storage Conditions

Modules

With regard to shipping and storage conditions, the modules meet the requirements of IEC 61131, Part 2. The following details apply to modules that are shipped and stored in their original packaging.

The climatic conditions conform to Class 2K4 for shipping and storage.

The mechanical conditions conform to IEC 60721, Part 3-2, Class 2M2.

| Type of condition | Permissible range |
|-------------------|---|
| Free fall | ≤ 1m (up to 10 kg) |
| Temperature | From – 40 °C to + 70°C |
| Air pressure | 1080 to 660 hPa (equivalent to a height of -1000 to 3500 m) |
| Relative humidity | 5 to 95%, non-condensing |

| Type of condition | Permissible range |
|--|--|
| Sinusoidal vibrations to IEC 60068-2-6 | 5 to 9 Hz: 3.5 mm 9 to 500 Hz: 9.8 m/s ² |
| Mechanical shock to IEC 60068-2-29 | 250 m/s ² , 6 ms, 1000 shocks |

Shipping backup batteries

To the extent possible, ship backup batteries in their original packaging. No special action need be taken for shipping backup batteries. The lithium content of the backup battery is less than 0.5 g.

Storing backup batteries

Store backup batteries in a cool and dry place. Their maximum shelf life is 10 years.



Warning

Risk of injury and material damage. Risk of hazardous substances escaping.

If handled wrongly, a lithium battery can explode; improper disposal of old lithium batteries may result in hazardous substances escaping. It is therefore imperative that you comply with the following information:

- Do not throw new or spent batteries into the fire and do not solder on the cell body (maximum temperature of 100 °C); do not recharge as there is a risk of explosion.
- Do not open the battery and replace it only with an identical type. Obtain replacement batteries only from Siemens – this ensures that you possess a short-circuit-proof type.
- Return old batteries to the battery manufacturer, or dispose of them as hazardous waste.

Passivation layer

When lithium batteries (lithium/thionyl chloride) are used, a passivation layer may form after very long periods of storage and cast doubt on the immediate ability of the battery to operate. Refer to section 4.4 for remedies.

A.4 Mechanical and Climatic Environmental Conditions

Operating conditions

The modules have been tested in a device that likewise conforms to the standards listed below. If the modules are operated in a device that does not meet these standards, compliance with the values cannot be guaranteed.

Usage with additional measures only

The CPU 41x-2 PCI and the PS extension board must **not** be used before additional action, for example, has been taken

- in locations subject to a high degree of ionizing radiation
- at locations subject to difficult operating conditions; for example, due to
 - occurrence of dust
 - etching vapors or gases
 - high electric or magnetic fields
- on systems necessitating special monitoring, such as
 - escalator systems
 - electric systems in particularly hazardous areas.

An additional measure might be operation in a housing or cabinet, for example.

Mechanical environmental conditions

The SIMATIC Box PC 620 is designed to meet high demands on mechanical ambient conditions (oscillation test with 1 g constant loading at a frequency of 58 to 500 Hz). CPUs 41x-2 PCI satisfy these requirements when used in a SIMATIC Box PC 620.

When fitted to other PCs having slots that are longer than 3/4 PCI and subjected to high mechanical loads, you must mechanically fix the rear PCB end in position, if necessary.

Tests for mechanical environmental conditions

The table below provides information on the type and scope of tests for mechanical environmental conditions.

| Test for ... | Test standard | Remarks |
|--------------|---|---|
| Vibrations | Vibration testing to IEC 60068, Part 2-6 (sine) | Type of vibration: frequency sweeps with a change rate of 1 octave/minute. $10 \text{ Hz} \leq f < 58 \text{ Hz}$, constant amplitude 0.075 mm $58 \text{ Hz} \leq f < 500 \text{ Hz}$, constant acceleration 0.5 g Vibration period: 10 frequency sweeps per axis along each of three mutually perpendicular axes |
| Impact | Impact testing to IEC 60068, Part 2-29 | Type of impact: half-sine Force of impact: 10 g peak value, 6 ms duration Direction of impact: 100 impacts along each of three mutually perpendicular axes |

Climatic environmental conditions

The modules must be used under the following climatic environmental conditions:

| | Permissible range | Remarks |
|-------------------------|--|--|
| Temperature | 5 to +45 °C | |
| Temperature change | Max. 10 °C/h | |
| Relative humidity | Max. 95% at +25 °C | Non-condensing, equivalent to RH stress level 2 to IEC 61131-2 |
| Air pressure | 1080 to 795 hPa (equivalent to a height of -1000 to 2000 m) | |
| Pollutant concentration | SO ₂ : < 0.5 ppm; RH < 60%, non-condensing H ₂ S: < 0.1 ppm; RH < 60%, non-condensing | Test: 10 ppm; 4 days 1 ppm; 4 days |

A.5 Certification for USA, Canada and Australia

USA

Federal Communications Commission Radio Frequency Interference Statement

This equipment has been tested and found to comply with the limits for a Class A digital device, pursuant to Part 15 of the FCC Rules. These limits are designed to provide reasonable protection against harmful interference when the equipment is operated in a commercial environment. This equipment generates, uses and can radiate radio frequency energy and, if not installed and used in accordance with the instruction manual, may cause harmful interference to radio communications. Operation of this equipment in a residential area is likely to cause harmful interference in which case the user will be required to correct the interference at his own expense:

Shielded cables

Shielded cables must be used with this equipment to maintain compliance with FCC regulations.

Modifications

Changes or modifications not expressly approved by the manufacturer could void the user's authority to operate the equipment.

Conditions of operations

This device complies with Part 15 of the FCC Rules. Operation is subject to the following two conditions: (1) this device may not cause harmful interference, and (2) this device must accept any interference received, including interference that may cause undesired operation.

Canada

Canadian Notice

This Class B digital apparatus complies with Canadian ICES-003.

Avis Canadien

Cet appareil numérique de la classe B est conforme à la norme NMB-003 du Canada.

Note for Australia



WinAC Slot 41x satisfies the requirements of Standard AS/NZS 3548 (Class B).

Networking

B

In this chapter

| Section | Contents | Page |
|---------|---------------------------------------|------|
| B.1 | Configuring an MPI or PROFIBUS Subnet | B-1 |
| B.2 | Network Components | B-1 |
| B.3 | Commissioning PROFIBUS-DP | B-25 |

B.1 Configuring an MPI or PROFIBUS Subnet

In this chapter

| Section | Contents | Page |
|---------|--------------------------------|------|
| B.1.1 | Network Operation | B-1 |
| B.1.2 | Fundamentals | B-3 |
| B.1.3 | Rules for Configuring a Subnet | B-5 |
| B.1.4 | Cable Lengths | B-12 |

B.1.1 Network Operation

Networks

You can connect a CPU 41x-2 PCI

- to an MPI subnet via the MPI
- to a PROFIBUS–DP subnet via the PROFIBUS-DP interface or MPI/PROFIBUS-DP interface
- to an Industrial Ethernet network via a SIMATIC Net CP – for example, a CP 1613 – or an Ethernet module – for example, 3Com Card
- to a PROFIBUS network via a SIMATIC Net CP – for example, a CP 5613.

Note

When using a SIMATIC Net CP and an Ethernet module simultaneously, you must make sure that the IP addresses are unique across both networks if you use the TCP/IP protocol (IP = Internet Protocol).

Identical configuration

The configuration of an MPI subnet is the same as for a PROFIBUS subnet. That means the same rules and the same components are used to configure the subnet.

Since the structure of an MPI subnet does not differ from that of a PROFIBUS subnet, general reference is made in the following sections to configuring a subnet.

Configuring communications

For the individual nodes of an MPI or PROFIBUS subnet to be able to communicate with each other, you have to assign them MPI and PROFIBUS-DP addresses, respectively. The steps that have to be performed to assign these addresses and the points you have to watch out for are described in the manual *Configuring Hardware and Connections in STEP 7*.

B.1.2 Fundamentals

Device = node

Declaration: in the following, all devices that you connect on a network are called nodes.

Segment

A segment is a bus cable between two terminating resistors. A segment can contain up to 32 nodes. A segment is further limited by the permissible cable length as a function of the transmission rate.

Transmission rate

Transmission rates of 9.6 kbaud to 12 Mbaud are possible. By default, the transmission rate for MPI is 187.5 kbaud.

Connectable nodes

| MPI | PROFIBUS-DP |
|---|---|
| Programming devices (PGs) | Programming devices (PGs) |
| Operating and monitoring devices with separate power supply (OPs) | Operating and monitoring devices with separate power supply (OPs) |
| CPU 41x-2 PCI | PROFIBUS-DP masters |
| CPU 416-2 DP ISA, CPU 416-2 DP ISA Lite | PROFIBUS-DP slaves |
| S7-400/M7-400 | |
| S7-300/M7-300 | |
| S7-200 | |

Maximum number of nodes

| MPI | PROFIBUS-DP |
|--|--|
| Without RS 485 repeater: 32 (default) | Without RS 485 repeater: 32 |
| With RS 485 repeater: 127 default: 32 | With RS 485 repeater: 64 (for CPU 412-2 PCI) 125 (for CPU 416-2 PCI) |

MPI/PROFIBUS addresses

To ensure that all nodes can communicate with one another, you must allocate them an address:

- on the MPI subnet, an "MPI address" and a "highest MPI address"
- on the PROFIBUS subnet, a "PROFIBUS address"

Read how to do this in the *STEP 7* user documentation.

Default MPI addresses

The following table shows the default MPI addresses when the devices are supplied.

| Node (Device) | Default MPI address | Preset Highest MPI Address |
|---------------|---------------------|----------------------------|
| PG | 0 | – |
| OP | 1 | 32 |
| CPU | 2 | 32 |

Rules for MPI addresses

Observe the following rules before assigning MP addresses:

- all MPI addresses on an MPI subnet must be different.
- the highest possible MPI address must be \geq the highest actual MPI address and must be identical for all nodes. (Exception: a programming device is connected to several nodes.)

Operator panels and remote servicing adapter at the MPI/PROFIBUS-DP interface

Note

At the MPI/PROFIBUS-DP interface, pin 7 does not have 24 V for supplying, say, operator panels or remote servicing adapters.

S7-200 on the MPI subnet

Set the proper transmission rate for the S7-200 at the MPI.

Note

At 19.2 kbaud for communications with the S7-200, **no more than 8 nodes** (CPU, PG/OP, FM/CP with separate MPI address) are allowed on a subnet. You must **not configure global data communication**.

B.1.3 Rules for Configuring a Subnet

In this subsection

This section describes how to configure a subnet and provides examples.

Rules

Observe the following rules for connecting nodes on a subnet:

- **Before** you interconnect the individual nodes of the subnet you must assign the MPI address and the highest MPI address or the "PROFIBUS address" and the "highest PROFIBUS address" to each node.

Mark all the nodes in a subnet by putting their address on their housings. In this way, you can always see which node has been assigned which address in your system.

- **Before** you integrate a new node on the subnet, you must switch off its supply voltage.
- Connect all nodes on the subnet "in one line"; that is, integrate the stationary programming devices and OPs direct on the subnet.

Connect only those programming devices/OPs that are required for commissioning or maintenance via spur lines to the subnet.

- If you operate more than 32 nodes on a PROFIBUS subnet, you must connect the bus segments via RS 485 repeaters.

All bus segments in a PROFIBUS subnet must have at least one DP master and one DP slave between them.

- Connect ungrounded bus segments and grounded connected bus segments by means of RS 485 repeaters (refer to section B.2.4).

- For each RS 485 repeater used, the number of the maximum quantity of nodes per bus segment reduces – in other words, if there is one RS 485 repeater in a bus segment – the number of the remaining nodes in the bus segment must not be higher than 31. The number of RS 485 repeaters has **no** impact on the maximum number of nodes on the bus, however.

Up to 10 segments can be installed in series.

- To do this, switch on the terminating resistor at the first and last node of a subnet or a segment.

Data packets on the MPI subnet

Note the following peculiarity on the MPI subnet:

Note

Connecting an additional CPU to the MPI subnet during operation can lead to loss of data.

Remedy:

1. Disconnect the node to be connected from the supply.
 2. Connect the node to the MPI subnet.
 3. Switch the node on.
-

Recommendation for MPI addresses

Reserve MPI address "0" for a service programming device and "1" for a service OP that will be connected temporarily to the MPI if required. This means that you must assign different addresses to programming devices/OPs that are integrated in the MPI subnet.

Reserve MPI address "2" for a CPU. You thus prevent double MPI addresses occurring after connection of a CPU with default settings to the MPI network (for example, when replacing a CPU). This means that you must assign an MPI address greater than "2" to all CPUs on the MPI subnet.

Recommendation for PROFIBUS addresses

Reserve PROFIBUS address "0" for a service programming device that may subsequently be temporarily connected to the PROFIBUS subnet if required. Allocate other PROFIBUS addresses to all the programming devices integrated in the PROFIBUS subnet.

Components

You connect the individual nodes by means of bus connectors and the PROFIBUS-DP bus cable. Make sure that the bus connector is provided with a programming device socket so that a programming device can be connected if required.

Use RS 485 repeaters to interconnect segments or extend the cable.

Terminating resistor

A cable must be terminated with its surge impedance. To do this, switch on the terminating resistor at the first and last node of a subnet.

At least one of these two nodes has to be supplied with voltage.

Terminating resistor at bus connector

Figure B-1 shows where you connect the terminating resistor at the bus connector.



Figure B-1 Bus Connector: Terminating Resistor Connected and Switched Off

Terminating resistor on the RS 485 repeater

Figure B-2 shows you where to connect the terminating resistor on the RS 485 repeater.

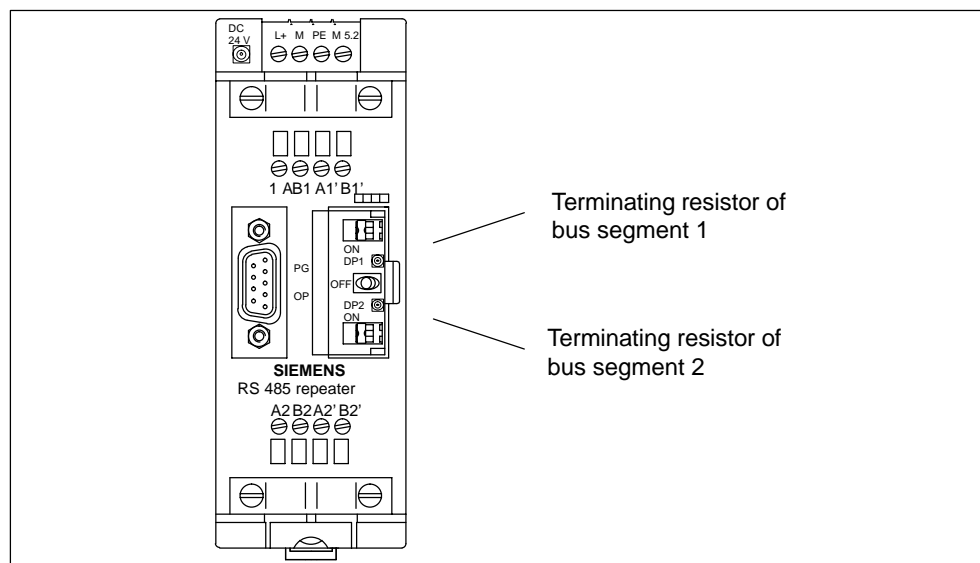

Figure B-2 The Terminating Resistor on the RS 485 Repeater

Example: terminating resistor on the MPI subnet

Figure B-3 shows where you have to connect the terminating resistor in one possible MPI subnet configuration.

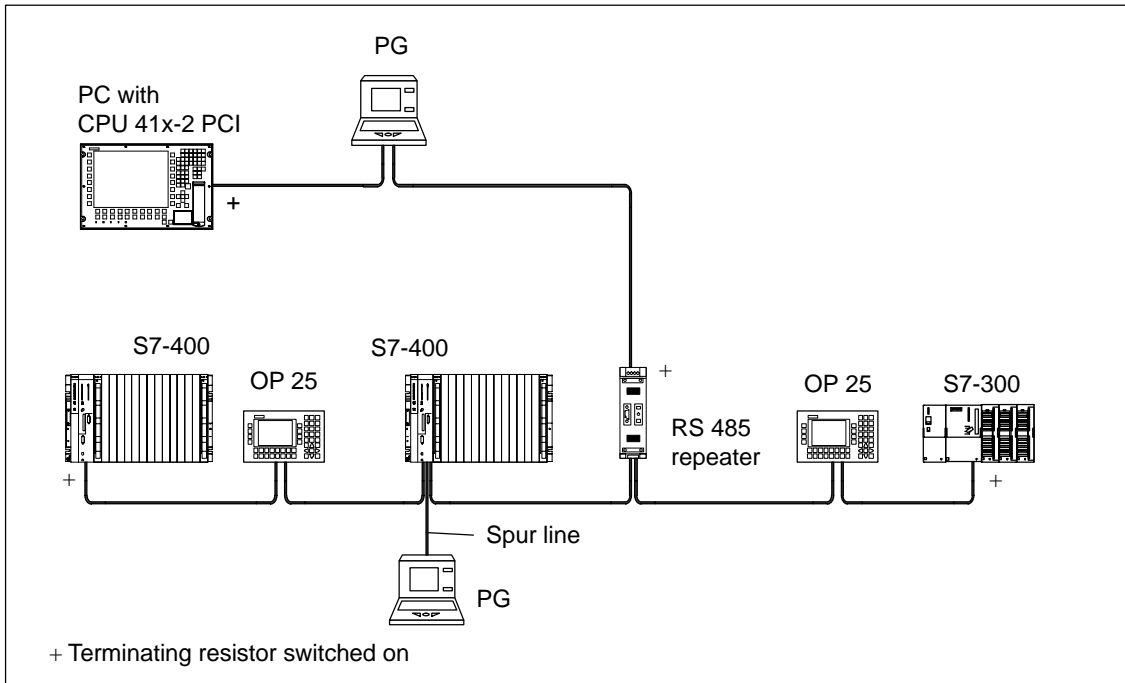

Figure B-3 Connecting Terminating Resistors on an MPI subnet

Example of an MPI Subnet

Figure B-4 shows an MPI subnet that is basically configured in accordance with the above rules.

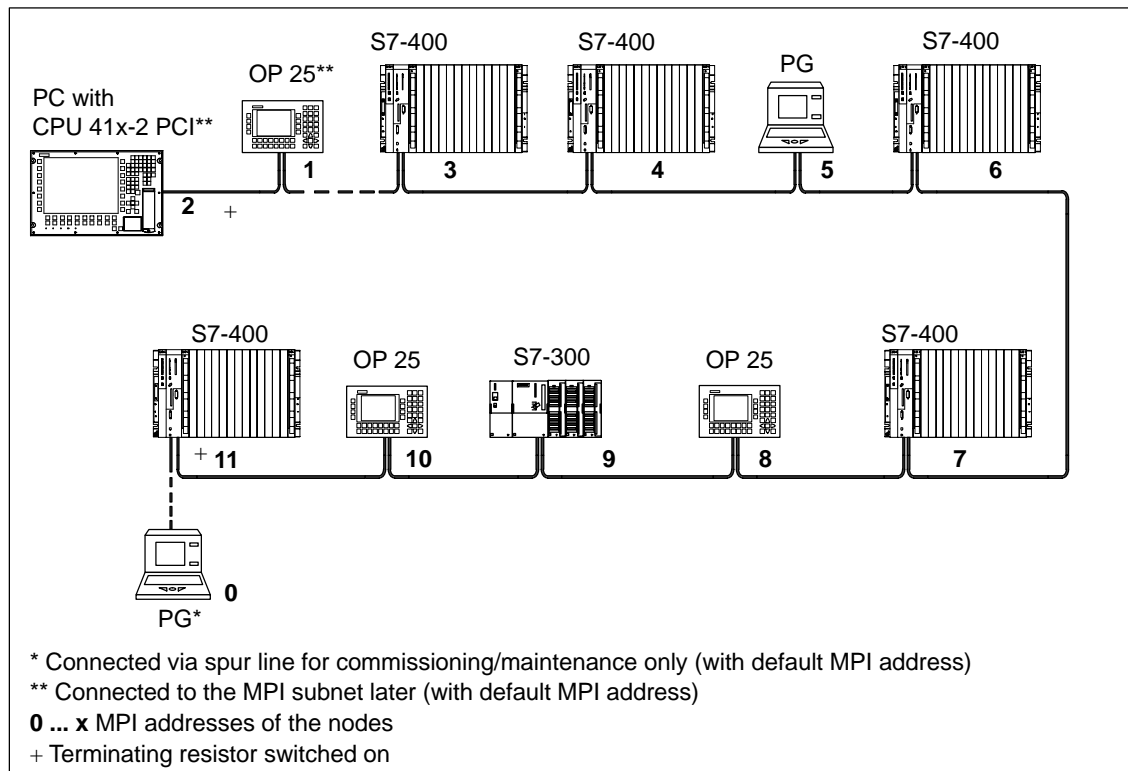

Figure B-4 Example of an MPI Subnet

Example of a PROFIBUS subnet

Figure B-5 shows a PROFIBUS subnet that is basically configured in accordance with the above rules.

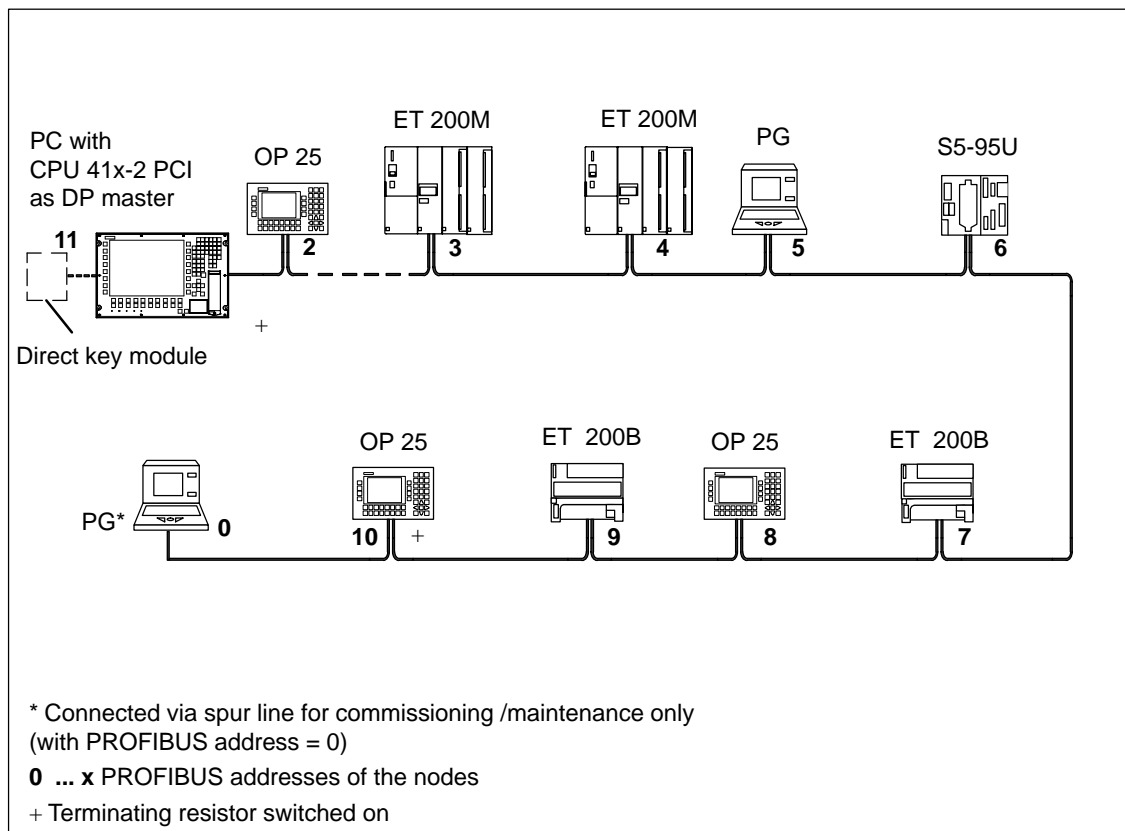

Figure B-5 Example of a PROFIBUS Subnet

Example containing a CPU 41x-2 PCI

Figure B-6 shows an MPI subnet with an integrated CPU 41x-2 PCI that is also operating as a DP master in a PROFIBUS subnet.

The MPI/PROFIBUS addresses can be assigned separately in both subnets without collisions occurring.

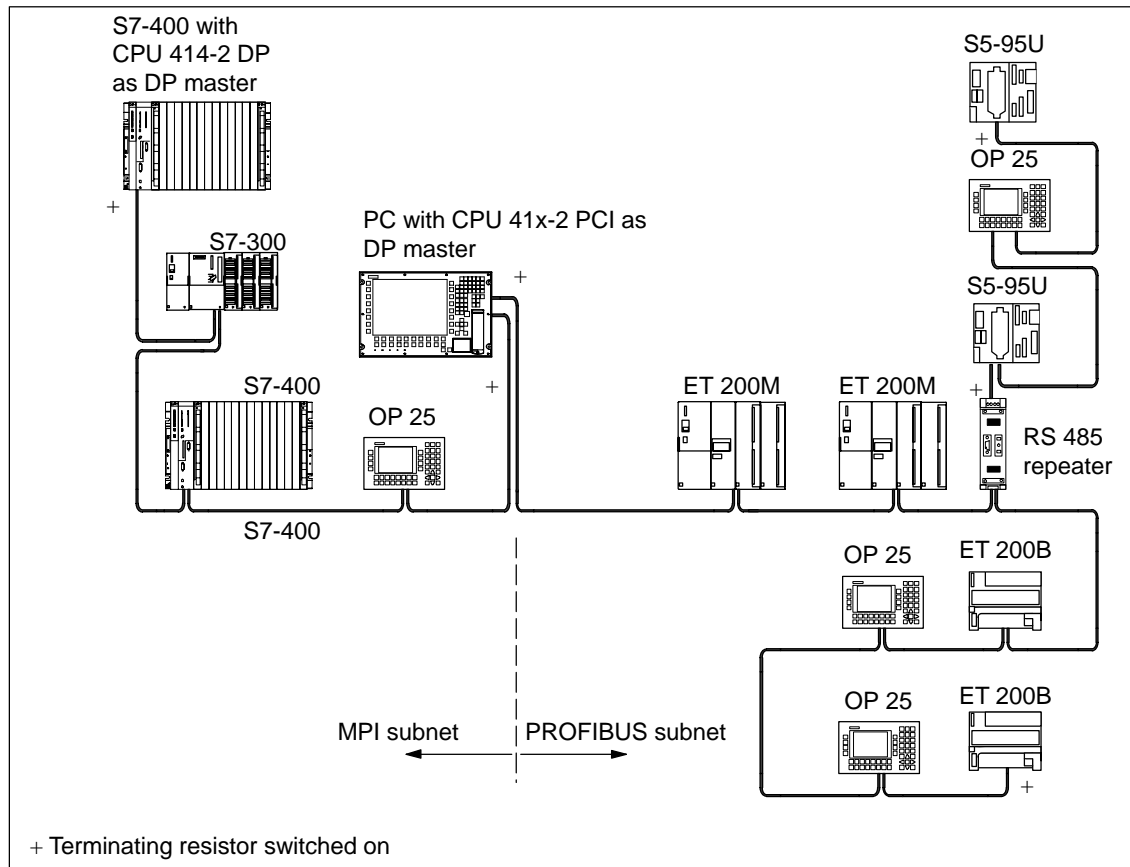

Figure B-6 Example of a Configuration with the CPU 41x-2 DP in an MPI and PROFIBUS Subnet

B.1.4 Cable Lengths

Segment in the MPI subnet

You can implement cable lengths of up to 50 m (164 ft.) in an MPI subnet segment. The 50 m is measured from the first node to the last node of a segment.

Table B-1 Permissible Cable Lengths in an MPI Subnet Segment

| Transmission rate | Maximum cable length of a segment (in m) |
|-----------------------|--|
| 9.6 kbaud to 12 Mbaud | 50 |

Segment in PROFIBUS subnet

The cable length in a segment of a PROFIBUS subnet depends on the transmission rate (see Table B-2).

Table B-2 Permissible Cable Lengths in a PROFIBUS Subnet Depending on the Transmission Rate

| Transmission rate | Maximum cable length of a segment (in m) |
|--------------------|--|
| 9.6 to 187.5 kbaud | 1000 |
| 500 kbaud | 400 |
| 1.5 Mbaud | 200 |
| 3 to 12 Mbaud | 100 |

Longer cable lengths

If you want to implement cable lengths above those permitted in a segment, you must use RS 485 repeaters. The maximum possible cable lengths between two RS 485 repeaters are the same as a segment cable length (refer to Tables B-1 and B-2). Please note that these maximum cable lengths only apply if **no** other node is installed between the two RS 485 repeaters. You can connect up to 9 RS 485 repeaters in series.

When counting the total number of all nodes to be connected, you must take into account that an RS 485 repeater counts as a node of the MPI subnet, even if it is not assigned a separate node address. Using RS 485 repeaters lowers the number of nodes.

Length of the spur lines

If you do not attach the bus cable directly to the bus connector (for example when using a PROFIBUS bus terminal), you must take into account the maximum possible length of the spur line.

The following table lists the maximum permissible lengths of spur lines per segment:

As of 3 Mbaud, use only the programming device connecting cable with the Order No. 6ES7 901-4BD00-0XA0 to connect the programming device. You can use more than one programming device connecting cable with this Order Number in one bus configuration. Other types of spur lines must not be used.

Table B-3 Lengths of Spur Lines per Segment

| Transmission rate | Max. length of spur line per segment | Number of nodes with spur line length of ... | |
|--------------------|--------------------------------------|--|---------------|
| | | 1.5 m or 1.6 m | 3 m (9.8 ft.) |
| 9.6 to 93.75 kbaud | 96 m | 32 | 32 |
| 187.5 kbaud | 75 m | 32 | 25 |
| 500 kbaud | 30 m | 20 | 10 |
| 1.5 Mbaud | 10 m | 6 | 3 |
| 3 to 12 Mbaud | – | – | – |

Example:

Figure B-7 shows you a possible configuration for an MPI subnet. This example illustrates the maximum possible distances in an MPI subnet.

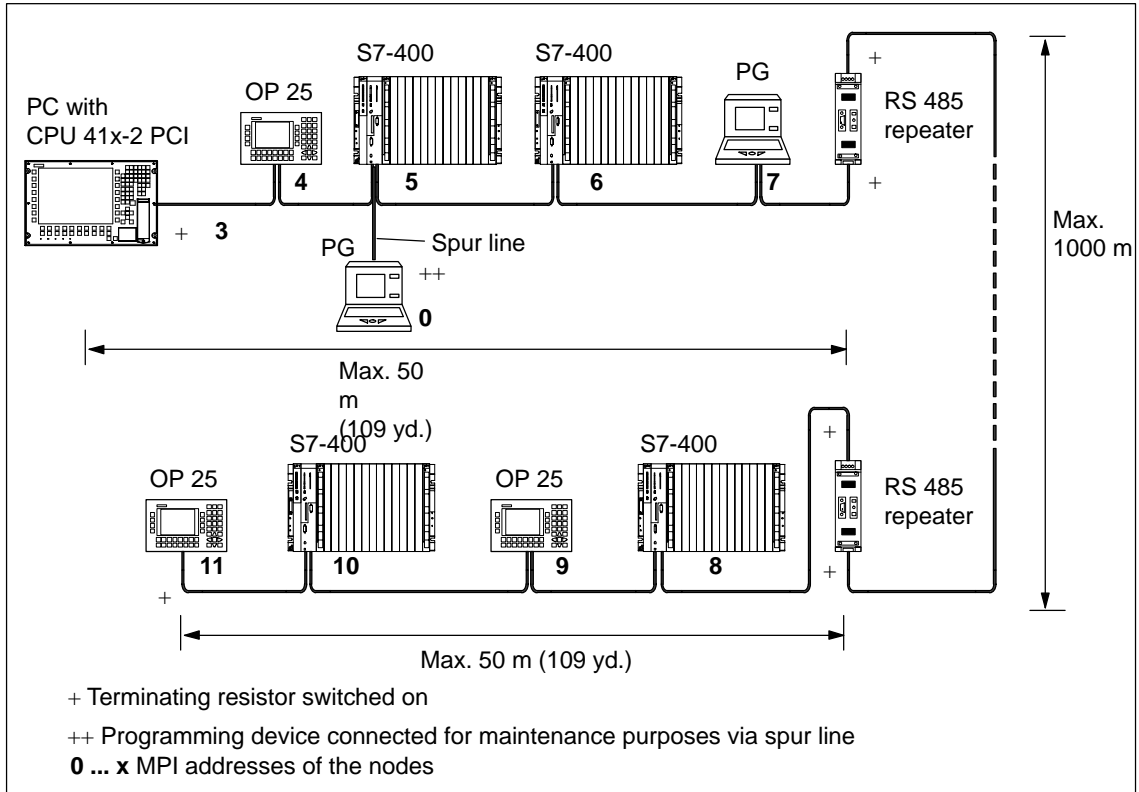

Figure B-7 Cable Lengths in an MPI Subnet

B.2 Network Components

In this chapter

This section describes the properties of the network components and information for their installation and handling.

| Section | Contents | Page |
|---------|---|------|
| B.2.1 | PROFIBUS Bus Cable | B-15 |
| B.2.2 | Bus Connector | B-17 |
| B.2.3 | Plugging the Bus Connector into Modules | B-18 |
| B.2.4 | RS 485 Repeater | B-20 |
| B.2.5 | RS 485 Repeater in Ungrounded and Grounded Mode | B-22 |
| B.2.6 | Technical Specifications of the RS 485 Repeater | B-24 |

B.2.1 PROFIBUS Bus Cable

Purpose

Table B-4 Network Components

| Purpose | Components | Description |
|--|---|--|
| ... to configure a network | PROFIBUS bus cable | Section B.2.1 |
| ... to connect a node to the network | Bus connector | Section B.2.2 |
| ... to amplify the signal ... to connect segments | RS 485 Repeater | Section B.2.4 |
| ... to convert the signal for a fiber-optic network (for PROFIBUS-DP network only) | Optical link module | In the manual <i>SIMATIC NET PROFIBUS Networks</i> |
| ... to connect programming devices/OPs to the network | Programming device connecting cables (spur lines) | Section B.1.4 |

PROFIBUS bus cable

We can supply the following PROFIBUS bus cables (refer to ST 70 Catalog):

| | |
|---|----------------|
| PROFIBUS bus cable | 6XV1 830-0AH10 |
| PROFIBUS underground cable | 6XV1 830-3AH10 |
| PROFIBUS drum cable | 6XV1 830-3BH10 |
| PROFIBUS bus cable with PE sheath (for food and beverages industry) | 6XV1 830-0BH10 |
| PROFIBUS bus cable for festooning | 6XV1 830-3CH10 |

Properties of the PROFIBUS bus cable

The PROFIBUS bus cable is a two-core, shielded twisted-pair cable with the following properties:

Table B-5 Properties of the PROFIBUS Bus Cable

| Properties | Values |
|---------------------------------------|---|
| Line impedance | Approx. 135 to 160 Ω (f = 3 to 20 MHz) |
| Loop resistance | $\leq 115 \Omega/\text{km}$ |
| Effective capacitance | 30 nF/km |
| Attenuation | 0.9 dB/100 m (f = 200 kHz) |
| Permissible cross-sectional core area | 0.3 mm ² to 0.5 mm ² |
| Permissible cable diameter | 8 mm \pm 0.5 mm |

Rules for laying

When laying the PROFIBUS bus cable, you should take care not to:

- Twist the cable
- Stretch the cable
- Compress the cable

You should also observe the following when laying the indoor bus cable (d_A = outer diameter of the cable):

Table B-6 Specifications for Installation of Indoor Bus Cable

| Properties | Specifications |
|--|--|
| Bending radius (one-off) | $\geq 80 \text{ mm } (10 \times d_A)$ |
| Bending radius (multiple times) | $\geq 160 \text{ mm } (20 \times d_A)$ |
| Permissible temperature range during installation | $-5 \text{ }^\circ\text{C}$ to $+50 \text{ }^\circ\text{C}$ |
| Storage and stationary operating temperature range | $-30 \text{ }^\circ\text{C}$ to $+65 \text{ }^\circ\text{C}$ |

B.2.2 Bus Connector

Purpose of the bus connector

The bus connector is used to connect the PROFIBUS cable to the MPI or PROFIBUS-DP interface. You thus make the connections to further nodes.

You can use the following bus connectors for the CPU 41x-2 PCI:

- Up to 12 Mbaud (35° outgoing feeder cable)
 - Without programming device socket (6ES7 972-0BA40-0XA0)
 - With programming device socket (6ES7 972-0BB40-0XA0)
- Up to 12 Mbaud (180° outgoing feeder cable)
 - Without programming device socket (6GK1 500-0EA02)

Note

Since the two DP and DP/MPI interfaces are beneath each other, we recommend that you use the bus connector with the Order Number 6GK1 500-0EA02 for reasons of space.

Appearance (6GK1 500-0EA02):

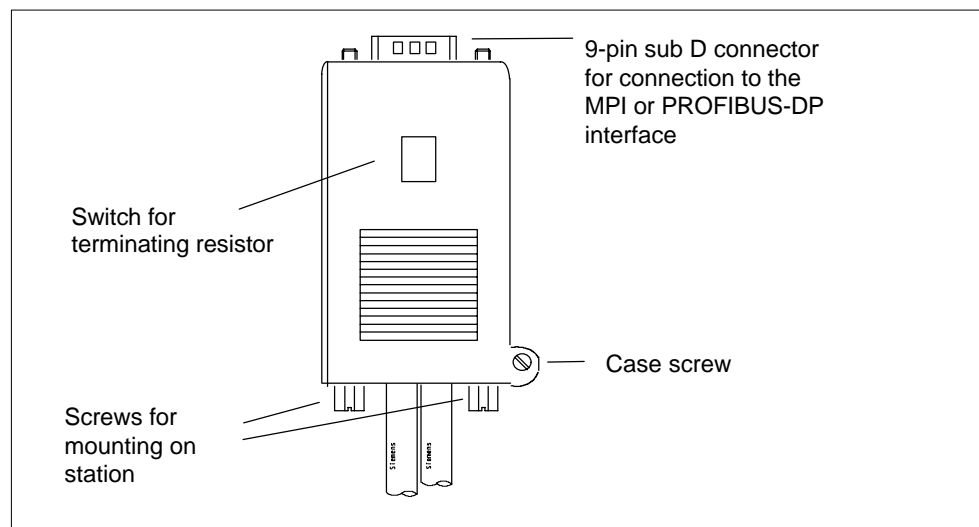

Figure B-8 Straight Bus Connector

B.2.3 Plugging the Bus Connector into Modules

Connecting bus cables to bus connectors (6GK1 500-0EA02)

Connect the bus cable to the bus connector as follows:

1. Prepare the cable ends in accordance with the dimensions shown in Figure B-9.
Remove the sheath from the cable over a distance of 22.5 mm from the end of the cable (the braided shield must not be damaged)
Shorten the braided shield, foil shielding and inter-polar gap by 7.5 mm.
Strip 6 mm of insulation from the ends of the cores.
2. Open the casing of the bus connector by loosening the casing screws and removing the cover.
3. Insert cores A and B into the screw-type terminal block and screw both cores (with stranded cores, use wire end ferrules having a diameter of 0.5 mm² or 0.75 mmØ)
4. Press the cable sheaths between the corresponding clamping straps to fix the cable in place.
5. Make sure that the bare cable shield is under the shield clamp.
6. Make sure that the supports and fleece (for example, for the trailing cable) do not cover the foil shielding.
7. Screw the casing back on.
8. Connect the terminating resistor to the segment ends of the bus connectors.

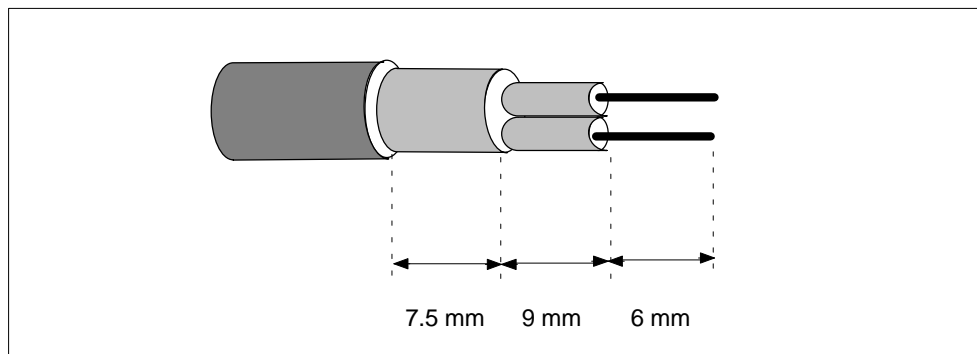

Figure B-9 Stripping Length for Connecting to the Bus Connector (6GK1 500-0EA02)

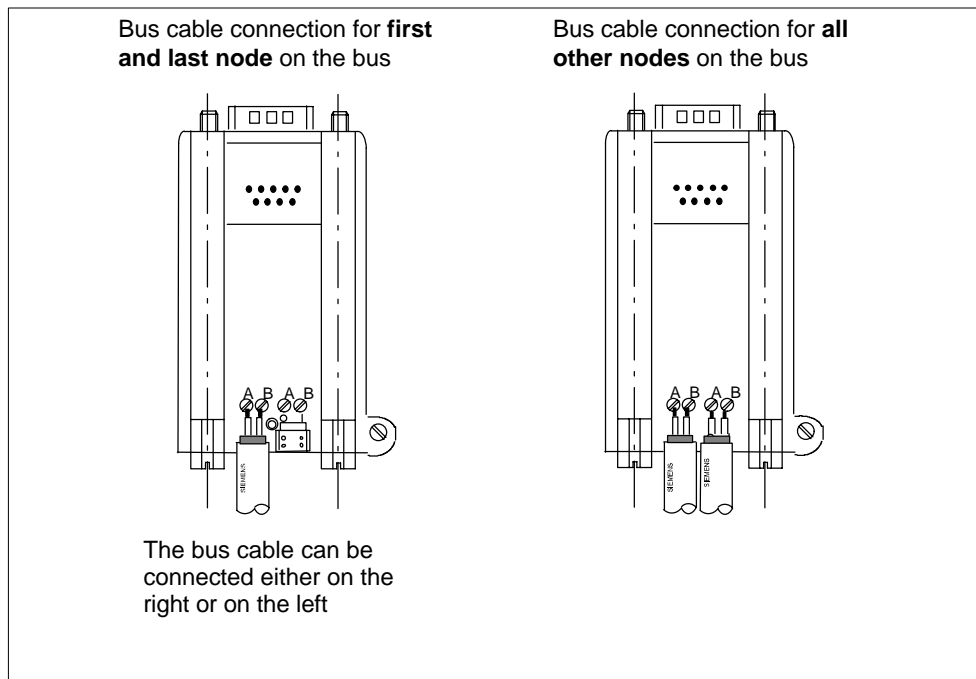

Figure B-10 Connecting the Bus Cable to the Bus Connector

Plugging the bus connector into the module

Proceed as follows to connect the bus connector:

1. Plug the bus connector into the module.
2. Screw the bus connector tight on the module.
3. If the bus connector is installed at the start or end of a segment, you must connect the terminating resistor (switch setting "ON").

The nodes with a connected terminating resistor must always be supplied with voltage during startup and operation.

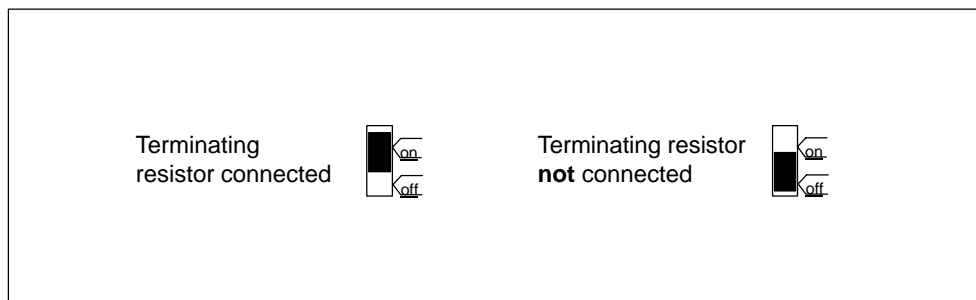

Figure B-11 Connecting/Disconnecting the Terminating Resistor

Removing the bus connector

With a **looped-through bus cable**, you can unplug the bus connector from the PROFIBUS-DP interface at any time, without interrupting data communication on the bus.



Warning

A data communication error may occur on the network.

A network segment must always be terminated at both ends with the terminating resistor. This is not the case, for example, if the power supply is not activated on the last slave with a bus connector. Since the bus connector draws power from the node, the terminating resistor has no effect.

Please make sure that power is always supplied to nodes on which the terminating resistor is active.

B.2.4 RS 485 Repeater

Appearance

The table below shows the appearance of the RS 485 repeater and lists its functions.

| Appearance of repeater | No. | Function |
|--|-----|--|
| <p>The diagram shows the front panel of a Siemens RS 485 repeater. At the top left is a DC 24V power supply terminal block with terminals L+, M, PE, M 5, 2. Below it are two shield clamp terminals. The main section contains two DP1 and DP2 ports, each with an ON/OFF switch. At the bottom are two bus cable connection terminals (A2 B2 A2' B2') and a slide mechanism. A jumper is located at the very bottom.</p> | ① | Connection of the 24 V DC power supply |
| | ② | Shield clamp for strain relief and grounding of the bus cable of bus segment 1 and bus segment 2 |
| | ③ | Connection of the bus cable of bus segment 1 |
| | ④ | Switch for terminating resistor of bus segment 1 |
| | ⑤ | Switch for OFF mode (bus segments 1 and 2 are isolated from each other) |
| | ⑥ | Switch for terminating resistor of bus segment 2 |
| | ⑦ | Connection of the bus cable of bus segment 2 |
| | ⑧ | Slide for installing and removing the RS 485 repeater on a standard sectional rail |
| | ⑨ | Interface for PG/OP on bus segment 1 |
| | ⑩ | Jumper for grounded or ungrounded configuration |

The purpose of the RS 485 repeater

The RS 485 repeater amplifies data signals on bus lines and interconnects network segments.

You need an RS 485 repeater if:

- more than 32 nodes are connected to the network
- a grounded segment is to be connected to a non-grounded segment, or
- the maximum cable length of a segment is exceeded.

Rules

If you configure the bus with RS 485 repeaters, the following applies:

- not more than 9 RS 485 repeaters must be connected in series.
- the maximum cable length between two nodes must not be greater than the values shown in the table below for the RS 485 repeater:

| Transmission rate | Maximum cable length BETWEEN 2 node (in m) with RS 485 repeater (6ES7 972-0AA01-0XA0) |
|--------------------|---|
| 9.6 to 187.5 kbaud | 10000 |
| 500 kbaud | 4000 |
| 1.5 Mbaud | 2000 |
| 3 to 12 Mbaud | 1000 |

Mounting

Mount the RS 485 repeater on a 35 mm standard sectional rail.

Wiring the power supply

Proceed as follows to wire the power supply of the RS 485 repeater:

1. Loosen screws "M" and "PE".
2. Strip the insulation from the 24 V DC power supply cable.
3. Connect the cable to terminals "L+" and "M" or "PE".

Terminal "M5.2"

Terminal "M5.2" is a terminal that you do not need to wire, as it is only used for servicing. Terminal "M5.2" supplies the reference potential. You need this reference potential to measure the voltage characteristic between terminals "A1" and "B1".

Connecting the PROFIBUS bus cable

You must connect the PROFIBUS bus cable to the RS 485 repeater as follows:

1. Cut the PROFIBUS bus cable to the length you require.
2. Strip the insulation off the PROFIBUS bus cable as shown in the following figure.

The braided shield must be turned up onto the cable. Only in this way can the shielding point later act as a strain relief and a shield support element.

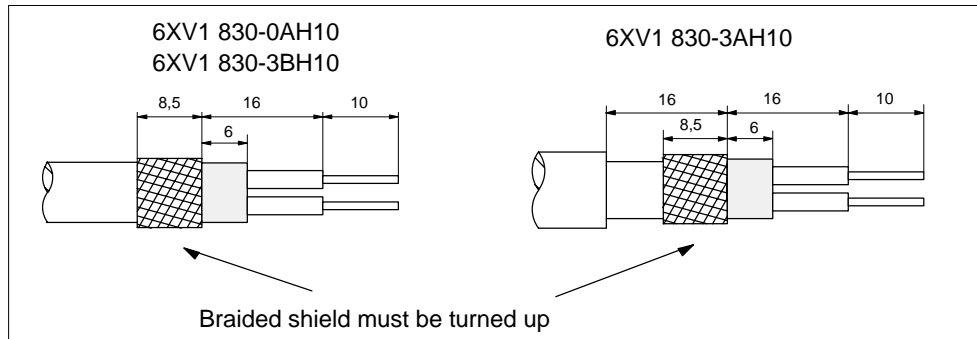

Figure B-12 Preparing the PROFIBUS Bus Cable

3. Connect the PROFIBUS bus cable to the RS 485 repeater:
 - Connect similar cores (green/red for PROFIBUS bus cable) to similar terminals A or B (for example, always connect a green wire to terminal A and a red wire to terminal B).
 - If the RS 485 repeater is the first or last node on the bus, **you must connect the bus cable on the left** (A1, B1 and A2, B2).
4. Tighten the screen clamps such that the shield is bare under the screen clamp.

B.2.5 RS 485 Repeater in Ungrounded and Grounded Mode

Decision

The RS 485 repeater is...

- grounded if all nodes in the segment are also operated in grounded mode
- ungrounded if all nodes in the segment are also operated in ungrounded mode

Note

Bus segment 1 is grounded if you connect a programming device to the PG/OP socket of the RS 485 repeater. Grounding is performed because the MPI on the PG is grounded and the PG/OP socket is connected internally to bus segment 1 in the RS 485 repeater.

Grounded operation of the RS 485 repeater

For grounded operation of the RS 485 repeater, terminals "M" and "PE" must have a jumper on the top of RS 485 repeater.

Ungrounded operation of the RS 485 repeater

For ungrounded operation of the RS 485 repeater, terminals "M" and "PE" must not have a jumper on the top of the RS 485 repeater. In addition, the power supply of the RS 485 repeater must be ungrounded.

Optical isolation between bus segments

Bus segment 1 and bus segment 2 are optically isolated from each other. The PG/OP interface is connected internally to the connection for bus segment 1. The following figure, Figure B-13, shows the front side of the RS 485 repeater.

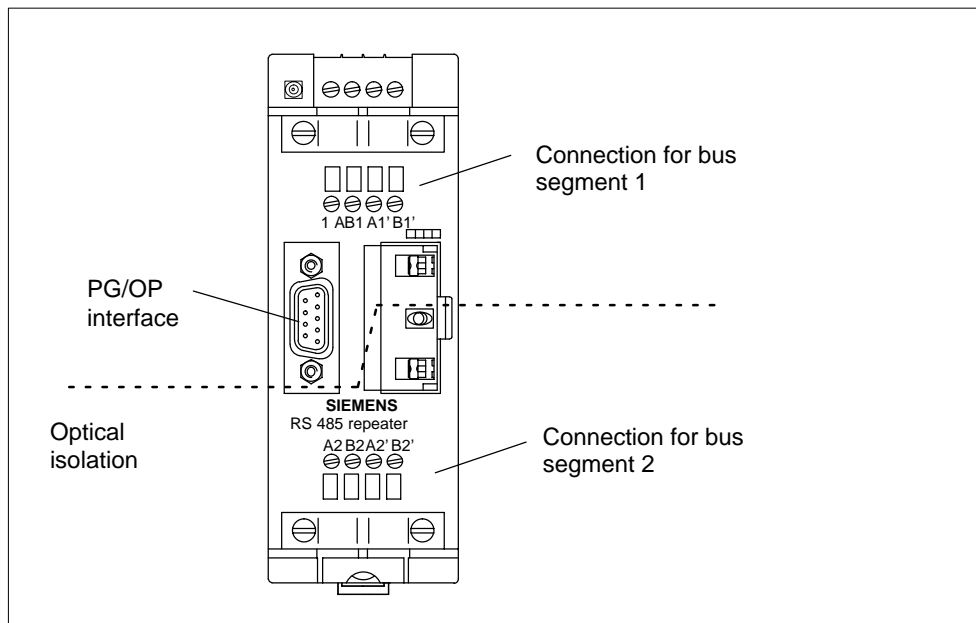

Figure B-13 Optical Isolation

Amplification of bus signals

The bus signals are amplified between the connection for bus segment 1 or the PG/OP interface and the connection for bus segment 2.

B.2.6 Technical Specifications of the RS 485 Repeater

| Technical specifications | |
|--------------------------------------|---|
| Power supply | |
| • Rated voltage | 24V DC |
| • Ripple | 20.4 to 28.8 V DC |
| Current consumption at rated voltage | |
| • without load on PG/OP socket | 200 mA |
| • load on PG/OP socket (5 V/90 mA) | 230 mA |
| • load on PG/OP socket (24 V/100 mA) | 300 mA |
| Optical isolation | Yes, 500 V AC |
| Connection of fiber-optic cables | Yes, via repeater adapter |
| Redundant operation | No |
| Transmission rate | Detected automatically by the RS 485 repeater 9.6; 19.2; 45.45; 93.75; 187.5; 500 kbaud 1.5; 3; 6; 12 Mbaud |
| Degree of protection | IP 20 |
| Dimensions W × H × D (in mm) | 45 × 128 × 67 |
| Weight (incl. packing) | 350 g |

Pin assignment of the sub D connector (PG/OP socket)

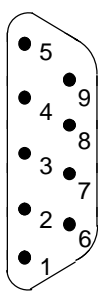
| View | Pin No. | Signal name | Designation |
|---|---------|-------------|---|
|  | 1 | – | – |
| | 2 | M24V | 24 V chassis ground |
| | 3 | RxD/TxD-P | Data line B |
| | 4 | RTS | Request To Send |
| | 5 | M5V2 | Data reference potential (from station) |
| | 6 | P5V2 | Supply plus (from station) |
| | 7 | P24V | 24 V |
| | 8 | RxD/TxD-N | Data line A |
| | 9 | – | – |

B.3 Commissioning PROFIBUS-DP

Introduction

This section describes the steps you have to perform when you commission a PROFIBUS-DP network with a CPU 41x-2 PCI as a DP master.

Requirements

Before you can commission the PROFIBUS-DP network, the following requirements have to be met:

- The PROFIBUS-DP network is connected (refer to section 6.3).
- You have configured the PROFIBUS-DP network in STEP 7 and assigned a PROFIBUS-DP address and address space to each node (refer to the manual *Configuring Hardware and Connections in STEP 7 Version 5.0*). Note that with some DP slaves you also have to set address switches (refer to the description of the DP slaves in question).

Commissioning

Perform the following steps to commission the PROFIBUS-DP network:

1. Load the configuration you created in STEP 7 for the PROFIBUS-DP network (setpoint configuration) with the programming device into the CPU. The procedure for this is described in the STEP 7 user guide.
2. Switch on all of the DP slaves.
3. Switch the CPU from STOP to RUN.

CPU behavior during startup

During startup, the CPU compares the setpoint configuration with the actual configuration. Set the time it takes for the comparison in STEP 7 with the "Module Time Limits" parameter in the "Startup" parameter field when assigning parameters to the module.

If the setpoint configuration is identical to the actual configuration, the CPU goes to RUN.

If the setpoint configuration is not the same as the actual configuration, the behavior of the CPU depends on the setting of the parameter "Startup when Setpoint Not equal to Actual Configuration"

| Startup when Setpoint Not Equal to Actual Configuration = Yes (Default) | Startup when Setpoint Not Equal to Actual Configuration = No |
|--|---|
| The CPU goes to RUN | The CPU remains at STOP, and at the end of the time set for the "Module Time Limits" parameter, the EXT F LED display flashes. The flashing EXT F LED indicates that at least one DP slave is not addressable. In this case, check whether all DP slaves are switched on, or read out the diagnostic buffer (see <i>Configuring Hardware STEP 7</i>). |

To set the "Startup" parameter, refer also to *Configuring Hardware STEP 7* and the online Help in STEP 7.

FAQs: Frequently Asked Questions about WinAC Slot 41x



In this chapter

| Section | Description | Page |
|---------|---|------|
| | Questions relating to the PS extension board | |
| C.1 | When do I use the PS extension board? | C-2 |
| C.2 | Why does the battery supply not reside on the CPU 41x-2 PCI? | C-2 |
| C.3 | How can I make without a PS extension board? | C-3 |
| C.4 | How can I save user data without a PS extension board when powering down and up? | C-4 |
| C.5 | Why do I still have to connect the PS extension board to the power supply of the PC (Y-cable)? | C-4 |
| | Questions relating to the memory card | |
| C.6 | When do I use a FLASH card and when a RAM card? | C-5 |
| C.7 | Is operation possible without a memory card? | C-5 |
| | Questions relating to PROFIBUS-DP | |
| C.8 | Can WinAC Slot 41x also be operated as a DP slave? | C-6 |
| C.9 | Does the PROFIBUS-DP interface integrated on the CPU 41x-2 PCI support the DP services (SFC58/59)? | C-6 |
| | Questions relating to communication | |
| C.10 | Does WinAC Slot 41x support network routing? | C-6 |
| C.11 | Do I have to use another S7 driver to use the integrated Industrial Ethernet interface of the SIMATIC PC? | C-7 |
| | Questions relating to the use of WinAC Slot on a PC | |
| C.12 | What are the advantages of using PCI? | C-7 |
| C.13 | How can PC applications access the process data of WinAC Slot 41x? | C-7 |
| C.14 | What are the advantages of using WinAC Slot 41x together with a SIMATIC Box PC 620? | C-8 |

C.1 When do I use the PS extension board?

Answer:

You will require the PS extension board

- when data retentivity is required after power down (including power failure), or
- when operation of the WinAC Slot 41x is required in conjunction with an external power supply (24 V).

Additional information

You will find further information on using the PS extension board in Section 2.2.

C.2 Why does the battery supply not reside on the CPU 41x-2 PCI?

Answer:

Because data retentivity is more than just backing up the work memory.

A consistent startup after power up presupposes that CPU data and states of relevance to startup were saved at the time of the last power down. The CPU 41x-2 PCI requires just a few milliseconds to back up these data.

With commercially available PC power supplies, the supply voltage is discontinued without warning so that intelligent modules, such as a CPU 412-x PCI, do not have time to back up user data.

The PS extension board helps to generate an early warning signal for the CPU 41x-2 PCI in the event of a power failure. This means that the CPU 41x-2 PCI is in a position to back up data of relevance to startup in a consistent manner in the course of the time that remains.

The user data are backed even during the power down state by means of the battery supply. The backup supply and the consistent backup of user data in the event of a power down are inseparable function units, and this is the reason why the following functions are combined on the PS extension board:

- battery supply
- generation of an advance signal warning of a power down
- external voltage supply as a redundant voltage supply option to the PC power supply unit.

Additional information

You will find information about the startup behavior of the CPU 41x-2 PCI in Section 2.2, and about the mounting and connection of the backup battery in Sections 2.3 and 4.4.

C.3 How can I make it without a PS extension board?

Answer:

When the working data (DBs, bit memories, counters, etc.) do not have to be retained after the PC is powered down or up – in other words, when the working data have to be re-installed during every restart of the PC.

Typical examples of this are...

- If you start with defined default settings after power up as a general rule.
- If you use machine controllers that are switched off in the evening and back on again the next morning.
- If the process data/recipes are being managed by an HMI or database system.

After the CPU 41x-2 PCI has been powered up, the process data/recipes are loaded onto the CPU 41x-2 PCI. The CPU 41x-2 PCI is then placed in the RUN operating mode.

In extremely rare cases an application will branch automatically to “AUTOMATIC” mode; however, this is normally initiated by the user.

Additional information

You will find information about the startup behavior of a CPU 41x-2 PCI not having a PS extension board in Section 2.2, and information about selecting a startup mode in Section 5.4.1.

C.4 How can I save user data without a PS extension board when powering down and up?

Answer:

In the event of power off, you normally shut down the PC in a defined manner. To save the current status of the data blocks, perform the following steps before you shut down the PC:

1. Change CPU 41x-2 PCI to "RUN".
2. Back up the current program status on the control panel of the CPU using **File > Archive**
Result: The CPU 41x-2 PCI backs up the contents of the data blocks. Bit memories, counters and timers are **not** backed up.
3. You can restore this program status after the PC has been powered up the next time. You have two options of doing this:
 - Automatically by means of the "Autoload" function, or
 - Manually with **File < Restore**

Additional information

You will find detailed information about backing up data without a PS extension board in Section 5.5 (Loading and saving the STEP 7 user program).

C.5 Why do I still have to connect the PS extension board to the power supply of the PC (Y-cable)?

Answer:

Because the technical design of the PS extension board is such that the voltage is supplied either by means of the internal PC power supply unit or the external power supply.

Additional information

You will find a description of installing and connecting the PS extension board in Chapter 2.

C.6 When do I use a FLASH card and when a RAM card?

Answer:

FLASH card:

- Typical example of use: when program changes are no longer necessary. The program resides on the memory card.
- The **CPU > Options > Autoload** function is **not** possible.

RAM card:

- Typical example of use: during commissioning – in other words, as long as program changes might be necessary
- The **CPU > Options > Autoload** function is possible.

Additional information

Memory cards are described in Chapter 10, and the **CPU > Options > Autoload** function is described in Section 5.5.2.

You will find a description of the **CPU > Options > Autoload** command in Section 5.6.3.

C.7 Is operation possible without a memory card?

Answer:

Yes, provided that the integrated load memory capacity of 256 kB in the CPU 41x-2 PCI is sufficient.

Additional information

You will find the technical specifications of CPUs 41x-2 PCI in Sections 8.2 (CPU 412-2 PCI) and 8.3 (CPU 416-2 PCI).

C.8 Can WinAC Slot 41x also be operated as a DP slave?

Answer:

Yes

Additional information

You will find further information about CPU 41x-2 PCI operation as a DP slave in chapter LEERER MERKER.

C.9 Does the PROFIBUS-DP interface integrated on the CPU 41x-2 PCI support the DP services (SFC58/59)?

Answer:

Yes

C.10 Does WinAC Slot 41x support network routing?

Answer:

Using the "Routing" function, you can reach S7 stations online with a PG/PC beyond subnet borders. This means that you can access a DP slave from Industrial Ethernet using WinAC Slot 41x. Typical examples of usage are:

- Load application programs
- Load hardware configuration
- Execute test and startup functions.

For this purpose special "routing tables" for the gateways are automatically generated during network configuration. These routing tables are special system data and have to be loaded onto the different gateways – in other words, also onto the WinAC Slot 41x. Following that, the path to the selected programmable logic controller through the gateways can be found when the programmer goes online.

Additional information

You will find further information about the routing theory in the STEP 7 online Help.

C.11 Do I have to use another S7 driver to use the integrated Industrial Ethernet interface of the SIMATIC PC?

Answer:

You will find the drivers on the SIMATIC NET CD.

In addition, a SIK/SIIMATIC NET Industrial Ethernet-S7 license (A9SS1390) is required.

C.12 What are the advantages of using PCI?

Answer:

Most commercially available PCs today use the PCI bus.

This produces the following advantages:

- Considerably shorter bus transfer times and thus faster communication between PC applications and PC hardware
- Plug-in support – in other words, there is no need to set interrupts and addresses.

C.13 How can PC applications access the process data of WinAC Slot 41x?

Answer:

There are various options for doing this:

- S7-SAPI (SIMATIC NET)
- Prodrive MPI
- Through the SIMATIC Computing OPC and ActiveX interfaces, which are included in the package supplied to you
- By means of the SoftContainer, with which you can create simple applications for diagnostics or commissioning, for instance (included in the package supplied to you).
- Technological application created with T-Kit

Communication with ProTool/Pro or WinCC takes place through integrated interfaces.

C.14 What are the advantages of using WinAC Slot 41x together with a SIMATIC Box PC 620?

Answer:

WinAC Slot 41x satisfies the radio interference and radio interference (EMC) requirements for industrial, residential, business and commercial areas, as well as for small businesses.

On the SIMATIC Box PC 620, WinAC Slot 41x. satisfies the higher requirements for vibration testing up to 1 g. This means that this combination is particularly suitable for use in environments subject to high vibration.

Panel Control

D

In this chapter

The Panel is also available as an ActiveX component for use in SIMATIC Computing. Panel Control permits access from SIMATIC Computing's SoftContainer or from any ActiveX container.

Panel Control provides access to the operating modes of the CPU 41x-2 PCI. You can change the operating mode from STOP to RUN or RUN-P, or you can use the MRES button to reset the memory areas of the CPU 41x-2 PCI.

| Section | Description | Page |
|---------|---|------|
| D.1 | Accessing the CPU 41x-2 PCI with the Panel Control | D-2 |
| D.2 | Selecting the Control Engine for the Panel Control | D-5 |
| D.3 | Sample Programs Using the Panel Control | D-6 |
| D.4 | Evaluating the LED Indications of the Panel Control | D-10 |
| D.5 | Properties and Methods of the Panel Control | D-11 |
| D.6 | Events of the Panel Control | D-22 |

D.1 Accessing the CPU 41x-2 PCI with the Panel Control

The Panel Control corresponds to the front side of the S7 CPU modules. As shown in Figure D-1, the control contains check boxes for setting the operating mode of the CPU 41x-2 PCI, a button for resetting the memory area, and LED displays.

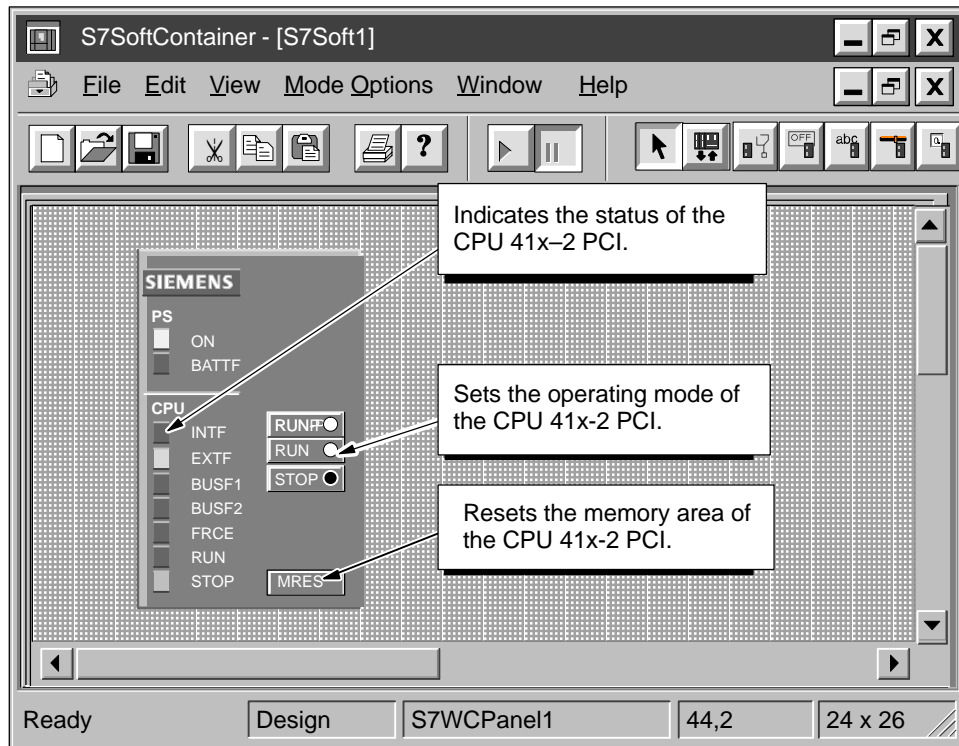

Figure D-1 Buttons and Indicators on the Panel Control



Warning

When you change the operating mode selection of the Panel Control, you are changing the operating mode of the CPU 41x-2 PCI in your actual process. If you select the MRES button, a memory reset is issued to the CPU 41x-2 PCI.

Resetting or changing the mode of the CPU 41x-2 PCI interrupts process operation. If equipment is not in a safe state, interrupting the process could result in death or serious injury to personnel, and/or damage to equipment.

Do not allow anyone to change the mode of the CPU 41x-2 PCI or issue a reset unless you have ensured that your equipment is in a safe state. Always install a physical emergency stop circuit for your machine or process.

Selecting the operating mode

The buttons RUN, RUNP and STOP on the Panel Control are equivalent to the different operating states of the CPU 41x-2 PCI. They are listed in Table D-1:

- In STOP mode, the CPU 41x-2 PCI does not execute the user program. To download a program that includes DBs, you must place the CPU 41x-2 PCI in STOP mode. On the transition to STOP mode, the outputs go to a safe state.
- In RUN mode, the CPU 41x-2 PCI executes the user program. You cannot download any new user program or logic blocks when the CPU 41x-2 PCI is in RUN mode.
- In RUN–P mode, the CPU 41x-2 PCI executes the user program. You can download new programs or logic blocks.

Clicking on the button places the CPU 41x-2 PCI in the selected operating mode. The status indicators on the Panel Control show whether the CPU 41x-2 PCI is in RUN (or RUN-P) mode or in STOP mode.

To allow an external source, such as the STEP 7 programming software, to change the operating mode of the CPU 41x-2 PCI, select either RUN or RUN-P mode. If the operating mode is changed by the external software, the selected button on the Panel Control does not change, but the LEDs indicate the actual operating mode of the Panel Control.

Table D-1 Buttons for Changing the CPU 41x-2 PCI Operating Mode

| Mode | Description |
|------|--|
| RUNP | The CPU 41x-2 PCI processes the user program. When the CPU 41x-2 PCI is in RUN-P mode (RUN-PROGRAM mode), you can trigger the following functions: <ul style="list-style-type: none"> • Upload a program from the CPU 41x-2 PCI to your computer or programming device. • Load a program into the CPU 41x-2 PCI. • Load individual blocks into the CPU 41x-2 PCI. |
| RUN | The CPU 41x-2 PCI processes the user program. You can upload a program from the CPU 41x-2 PCI to your PC or your programming device, but you cannot load programs into the CPU 41x-2 PCI. |
| STOP | The CPU 41x-2 PCI does not process the user program. When the CPU 41x-2 PCI is in STOP mode, you can trigger the following functions: <ul style="list-style-type: none"> • Upload a program from the CPU 41x-2 PCI to your computer or programming device. • Load a program into the CPU 41x-2 PCI. |

LEDs

The LED displays (BUSF1, BUSF2, INTF, EXTF, ON, BATF, FRCE, RUN, and STOP) show basic information about the CPU 41x-2 PCI, such as the current operating mode or the presence of an error condition. Table D-2 describes the different LED displays for the CPU panel of the CPU 41x-2 PCI. You cannot change the mode of the CPU 41x-2 PCI simply by clicking the LED displays.

If the user program contains a breakpoint, the two displays for RUN and STOP are activated for the time the breakpoint is active: the LED display for RUN mode flashes and the display for STOP mode is activated.

In the case of a restart, the two displays for RUN and STOP are activated: the LED display for RUN mode flashes and the display for STOP mode is activated during the restart. If the LED display for STOP mode is deactivated, the outputs are activated.

If all LED displays flash, the CPU 41x-2 PCI is in a defective state.

Table D-2 LED Displays

| LEDs | Description |
|------------------------------------|--|
| ON | Power supply. |
| BATF | Battery fault. |
| INTF | This indicator lights up to show error conditions within the CPU 41x-2 PCI, such as programming errors, firmware errors, arithmetic errors and timer errors. |
| EXTF | This indicator lights up to show error conditions that exist outside of the CPU 41x-2 PCI, such as hardware faults, parameter assignment errors, communication errors, and I/O errors. |
| BUSF1 BUSF2 | These indicators light up (either solid or flashing) to identify fault conditions in the communication with the distributed I/O. |
| FRCE | This indicator lights up to show that a Force request is active. |
| RUN STOP | Lights up (solid) to show the operating mode (RUN or STOP). When RUN is flashing and STOP is on (solid): <ul style="list-style-type: none"> • The CPU 41x-2 PCI performs a restart. • The user program has reached a breakpoint. |
| All status indicators are flashing | When all of the LED displays are flashing, the CPU 41x-2 PCI has detected an error condition that cannot be fixed by resetting the memory (MRES). To recover from this condition, you must perform the following tasks: Press Reset or perform POWER/DOWN POWER/UP on the PC or on the panel. |

Using the MRES button to reset the memory areas

The Panel Control provides a MRES button for resetting the memory areas to the default values and deleting the user program. If you click the "MRES" button, the CPU 41x-2 PCI goes to STOP mode and the following tasks are performed:

1. The CPU 41x-2 PCI deletes the entire user program, including data blocks (DBs).
2. The CPU 41x-2 PCI resets the memory areas (I, O, M, T and C).

After the memory has been reset, the diagnostics buffer remains intact, as does the MPI address.

D.2 Selecting the Control Engine for the Panel Control

When using the ActiveX Panel Control, you must specify the control engine to which to connect. The Panel does not connect to hardware automation systems or across networks. Figure D-2 shows the "Properties" dialog box for the Panel Control. Enter the names of the CPU 41x-2 PCI in the "Control Engine" box, e. g.:

- **CPU 412-2 PCI** or
- **CPU 416-2 PCI**

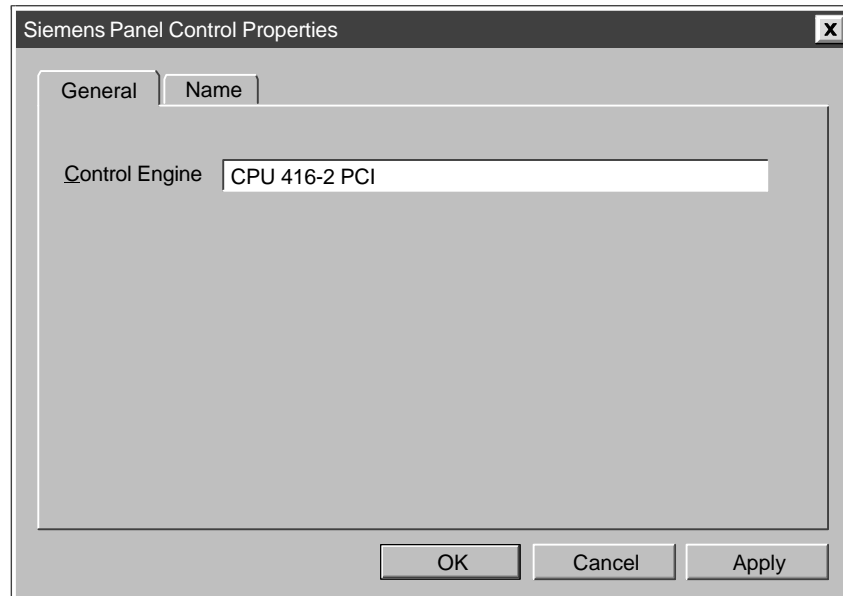

Figure D-2 Panel Control Properties (General Tab)

Note

If you are using a third-party container that allows you to view the other properties for the Panel Control, do not modify these properties or the values assigned to them.

D.3 Sample Programs Using the Panel Control

You can write programs to initiate actions based on the status of the Panel Control. The following sample programs provide examples of how you can write programs that use the Panel Control.

Changing the CPU 41x-2 PCI mode

Your program can change the operating mode (RUN, RUN-P, STOP) of the CPU 41x-2 PCI. Table D-3 provides sample subroutines that perform these tasks when you click a command button in the VB form.

- If the subroutine ConnectToCPU is called, the Panel Control connects to a specific CPU 41x-2 PCI.
- If the subroutine SetToRun is called, the operating mode of the CPU 41x-2 PCI changes to RUN mode.
- If the subroutine SetToRunP is called, the operating mode of the CPU 41x-2 PCI changes to RUN-P mode.
- If the subroutine SetToStop is called, the operating mode of the CPU 41x-2 PCI changes to STOP mode.

Table D-3 Connecting a CPU 41x-2 PCI and Changing the Operating Mode

| Visual Basic Code | |
|---------------------------------|---|
| Private Sub ConnectToCPU | |
| S7Panel1.ConnectCPU = True | 'Connect the Panel to the Selected Control Engine |
| End Sub | |
| Private Sub SetToRun | |
| S7Panel1.ModeCtrl = RUN_Switch | 'Change CPU 41x-2 PCI to RUN |
| End Sub | |
| Private Sub SetToRunP | |
| S7Panel1.ModeCtrl = RUNP_Switch | 'Change CPU 41x-2 PCI to RUN-P |
| End Sub | |
| Private Sub SetToStop | |
| S7Panel1.ModeCtrl = STOP_Switch | 'Change CPU 41x-2 PCI to STOP |
| End Sub | |

Configuring the security state of the Panel Control

You can design a custom application that uses the Panel Control, but allows the security for the application to determine whether a user can operate the Panel Control. Since your application will have its own password or other security checking, you do not require any additional security checking to be performed by the Panel Control.

The sample subroutines listed in Table D-4 provide sample code for accomplishing the following tasks:

- To bypass the security provided by the Panel Control, you set the SecurityState property of the Panel Control to `App_Does_Security`. The Panel Control now relies on the application to determine whether the user has permission to make changes in the CPU 41x-2 PCI.

In this example, the SecurityState property is set to this value when the form for the application loads.

- To ensure that a user must have permission from the application before allowing any changes to be made with the Panel Control, you set the SwitchOK property of the Panel Control to `False`. The button on the Panel Control will now respond to user requests only if the application changes the state of the SwitchOK property.

In this example, the SwitchOK property is set to `False` when the form for the application loads.

- To enable the user to make changes to the CPU 41x-2 PCI with the Panel Control, your application sets the SwitchOK property of the Panel Control to `True`.

When the PerformSecurityCheck subroutine determines that the user has permission to make changes with the Panel Control, the subroutine sets the SwitchOK property of the Panel Control to `True`. Until the SwitchOK property is set to `True`, the Panel Control does not make the change requested by the user.

Using this sample code, any time that a user requests the Panel Control to perform some task, the Panel Control determines whether the user has been given permission by the application to make the requested change. For example, when a user clicks on the "RUN" button of the Panel Control to change the CPU 41x-2 PCI from STOP mode to Run mode, the Panel Control checks the state of the SwitchOK property before changing the operating mode of the CPU 41x-2 PCI.

Table D-4 Configuring the Security State for the Panel Control

```
Visual Basic Code
' This sample application uses a Boolean parameter (AppPasswordValid)
' to allow changes to be made with the Panel Control

Dim AppPasswordValid As Boolean 'User is (or is not) allowed to make changes

Private Sub Form_Load()
' This section connects the Panel Control to the CPU 41x-2 PCI and
' initializes the properties of the Panel Control

' Set the control engine string for the CPU 41x-2 PCI
S7Panel.ControlEngine = WinAC

' You can enter "CPU 412-2 PCI", "CPU 416-2 PCI" or a symbolic name for
the CPU here

' Connect Panel Control to CPU 41x-2 PCI
S7Panel.ConnectCPU = True

' Initialize the SwitchOK property to False. This prevents any changes
' to be made until the application performs the security check
S7Panel.SwitchOK = False

' Set the security state to have the application perform the security check
S7Panel.SecurityState = App_Does_Security

End Sub

Private Sub PerformSecurityCheck()
' This subroutine provides the security checking for the application.
'
' The code that checks the security for the application goes here...
' If the user has permission to make changes, AppPasswordValid is set to True
' Otherwise, AppPasswordValid is set to False

' State of AppPasswordValid determines whether the Panel Control responds to the
' user
S7Panel.SwitchOK = AppPasswordValid

End Sub
```

Responding to changes in the state of the LEDs on the Panel Control

Table D-5 provides a sample subroutine that reads the state of the LED display for RUN mode and determines the color of the LED display and if the LED display is permanently on or is flashing. The constants that have been declared for the subroutine are the masks for the values of the LED display properties: CpuBusf1, CpuBusf2, CpuExtF, CpuFrce, CpuIntF, CpuRun and CpuStop.

Table D-5 Responding to Changes in the State of the LED Displays on the Panel Control

| Visual Basic Code |
|---|
| <pre>Private Sub S7Panel_UpdateState() These constants are the masks for the LED display properties: Const LED_GREEN = &H2 Const LED_3SEC = &H100 Const LED_ON = &H200 Const LED_05HZ = &H300 Const LED_20HZ = &H400 'For this example, RunLedColorTxt and RunLedStateTxt are text fields: 'RunLedColorTxt displays a message about the color of the LED display for 'RUN mode 'RunLedStateTxt displays a message about the state (on or flashing) 'of the LED display for RUN mode</pre> |
| <pre>If S7Panel.CpuRun = 0 Then RunLedColorTxt.Caption = "Color of the RUN mode LED display is gray" RunLedStateTxt.Caption = "RunLED is Off" End If</pre> |
| <pre>If ((S7Panel.CpuRun And LED_GREEN) = LED_GREEN) Then RunLedColorTxt.Caption = "Color of the RUN mode LED display is green" End If</pre> |
| <pre>If ((S7Panel.CpuRun And LED_ON) = LED_ON) Then RunLedColorTxt.Caption = "RUN mode LED display is activated and is not flashing)" End If</pre> |
| <pre>If ((S7Panel.CpuRun And LED_3SEC) = LED_3SEC) Then RunLedColorTxt.Caption = "RUN mode LED display flashes for 3 seconds" End If</pre> |
| <pre>If ((S7Panel.CpuRun And LED_05SEC) = LED_05HZ) Then RunLedColorTxt.Caption = "RUN mode LED display flashes at intervals of 5 Hz" End If</pre> |
| <pre>If ((S7Panel.CpuRun And LED_20SEC) = LED_20HZ) Then RunLedColorTxt.Caption = "RUN mode LED display flashes at intervals of 20 Hz" End If</pre> |
| <pre>End Sub</pre> |

D.4 Evaluating the LED Indications of the Panel Control

The Panel Control has the following LED displays:

- CpuBusf1
- CpuBusf2
- CpuExtF
- CpuFrce
- CpuIntF
- CpuRun
- CpuStop

You use the constants (hexadecimal values) listed in Table D-6 to evaluate the states of the LED displays on the Panel Control. These masks determine the status of the individual LED displays.

Table D-6 Masks for the Panel Control LED Displays

| Mask (hexadecimalvalue) | Description |
|-------------------------|--|
| 1 | Color of the LED display = orange |
| 2 | Color of the LED display = green |
| 3 | Color of the LED display = red |
| 100 | LED display flashes for 3 seconds |
| 200 | LED display activated (not flashing) |
| 300 | LED display flashes at a frequency of 0,5 Hz |
| 400 | LED display flashes at a frequency of 2,0 Hz |

D.5 Properties and Methods of the Panel Control

ActiveFilePath property

This read-only property provides the pathname to the control engine (CPU 41x-2 PCI).

Syntax:

```
[value =] object.ActiveFilePath
```

The ActiveFilePath property has these parts:

| Part | Description |
|---------------|---|
| <i>object</i> | The expression "object" refers to the Panel Control. |
| <i>value</i> | A string expression that evaluates to the name of the controller. |

AutoStart property

This property allows you to select the "autostart" feature for WinLC. This property is valid only for WinLC. For information about the autostart feature, refer to the WinLC documentation.

Syntax:

```
object.AutoStart [= value]
```

The AutoStart property has these parts:

| Part | Description |
|---------------|--|
| <i>object</i> | The expression "object" refers to the Panel Control. |
| <i>value</i> | A Boolean expression that specifies whether the autostart feature is enabled for <i>the object</i> . |

The settings for the *value* are:

| Setting | Description |
|---------|---|
| True | The autostart feature of WinLC is enabled. |
| False | (default) The autostart feature of WinLC is disabled. |

CheckPW property

This property determines whether the password entered was correct. If the password entered matches the password stored in the control engine, the control executes the requested action.

Syntax:

object.CheckPW [= *value*]

The CheckPW property has these parts:

| Part | Description |
|---------------|--|
| <i>object</i> | The expression "object" refers to the Panel Control. |
| <i>value</i> | An integer that determines whether the object performs the requested action. |

The settings for the *value* are:

| Setting | Description |
|----------------|---|
| 0 – Check_Wait | (default) The control engine is verifying the password. |
| 1 – Check_Good | The password entered was correct and the action is allowed. |
| 2 – Check_Bad | The password entered was incorrect and the action is not allowed. |

ConnectCPU property

This property establishes a connection to the S7 controller cancels this connection (CPU 41x-2 PCI).

Syntax:

object.ConnectCPU [= *value*]

The ConnectCPU method has these parts:

| Part | Description |
|---------------|--|
| <i>object</i> | The expression "object" refers to the Panel Control. |
| <i>value</i> | A Boolean expression that specifies whether the <i>object</i> establishes a connection to the S7 control engine. |

The settings for the *value* are:

| Setting | Description |
|---------|---|
| True | The <i>object</i> connects to the S7 controller. |
| False | (default) The <i>object</i> disconnects from the S7 controller. |

ControlEngine property

This property stores the pathname or identification of the control engine connected to the control.

Syntax:

```
object.ControlEngine [= value]
```

The ControlEngine property has these parts:

| Part | Description |
|---------------|--|
| <i>object</i> | The expression "object" refers to the Panel Control. |
| <i>value</i> | A string that specifies the pathname or identification of the control engine to be accessed by the <i>object</i> . |

CpuBusf1, CpuBusf2 properties

This read-only property displays the state of the communication indicators (BUSF1 and BUSF2) on the control. BUSF1 indicates the state of the distributed I/O for the control engine. If a second network is supported by the control engine, BUSF2 shows the status of the second network.

Syntax:

```
[value =] object.CpuBusf1
```

```
[value =] object.CpuBusf2
```

The CpuBusf1 and CpuBusf2 properties have these parts:

| Part | Description |
|---------------|--|
| <i>object</i> | The expression "object" refers to the Panel Control. |
| <i>value</i> | An integer expression that specifies the status of the bus fault (BUSF1 or BUSF2) on the object. |

Settings for the *value* are shown in Table D-6.

CpuExtF property

This read-only property shows the state of the External Error display on the control. External errors do not occur in the CPU of the control engine. They are wire breakage of the local inputs and outputs, for example.

Syntax:

```
[value =] object.CpuExtF
```

The syntax of the CpuExtF property has these components:

| Part | Description |
|---------------|--|
| <i>object</i> | The expression "object" refers to the Panel Control. |
| <i>value</i> | An integer expression that specifies the status of the EXTf indicator on the <i>object</i> . |

Settings for the *value* are shown in Table D-6.

CpuFrce property

This read-only property shows the state of the FRCE indicator on the control. The FRCE display lights to signal that a user-requested Force function is active. (Using the STEP 7 programming software, the user can stipulate that the control engine set or force an input or output to a specific value.)

Syntax:

[*value* =] **object.CpuFrce**

The CpuFrce property has these parts:

| Part | Description |
|---------------|--|
| <i>object</i> | The expression "object" refers to the Panel Control. |
| <i>value</i> | An integer expression that specifies the status of the FRCE indicator on the object. |

Settings for the *value* are shown in Table D-6.

CpuIntF property

This read-only property shows the state of the Internal Error display on the control. Internal faults are errors that are detected within the CPU module of the control engine, such as programming errors that cause the control engine to go to STOP mode.

Syntax:

[*value* =] **object.CpuIntF**

The CpuIntF property has these parts:

| Part | Description |
|---------------|--|
| <i>object</i> | The expression "object" refers to the Panel Control. |
| <i>value</i> | An integer expression that specifies the status of the INTF indicator on the object. |

Settings for the *value* are shown in Table D-6.

CpuRun property

This read-only property shows the state of the RUN mode display on the control.

Syntax:

[*value* =] **object.CpuRun**

The CpuRun property has these parts:

| Part | Description |
|---------------|--|
| <i>object</i> | The expression "object" refers to the Panel Control. |
| <i>value</i> | An integer expression that specifies the state of the RUN indicator. |

Settings for the *value* are shown in Table D-6.

CPURunning property

This read-only property indicates that the control engine is still running or in operation. The control queries the control engine, and if the control engine responds, the property is set to True.

Syntax:

[*value* =] *object.CpuRunning*

The CpuRunning property has these parts:

| Part | Description |
|---------------|---|
| <i>object</i> | The expression "object" refers to the Panel Control. |
| <i>value</i> | A Boolean expression that specifies whether the control engine is running and able to respond to the control. |

The settings for the *value* are:

| Setting | Description |
|---------|---|
| True | The control engine is running and has responded to the query by the control |
| False | (default) The control engine is not running or not responding. |

CpuStop value

This read-only property shows the state of the STOP mode indicator on the control.

Syntax:

[*value* =] *object.CpuStop*

The CpuStop property has these parts:

| Part | Description |
|---------------|---|
| <i>object</i> | The expression "object" refers to the Panel Control. |
| <i>value</i> | An integer expression that specifies the state of the STOP indicator. |

Settings for the *value* are shown in Table D-6.

FirmwareVersion property

This read-only property stores the revision level of the firmware in the control engine.

Syntax:

[*value* =] *object*.FirmwareVersion

The FirmwareVersion property has these parts:

| Part | Description |
|---------------|--|
| <i>object</i> | The expression "object" refers to the Panel Control. |
| <i>value</i> | A string value that describes the revision level of the firmware for the control engine. |

FmrSwitch property

This property restarts the backup battery.

Syntax:

object.FmrSwitch [= *value*]

The FmrSwitch property has these parts:

| Part | Description |
|---------------|--|
| <i>object</i> | The expression "object" refers to the Panel Control. |
| <i>value</i> | A Boolean expression that causes the control engine to restart the backup battery. |

The settings for the *value* are:

| Setting | Description |
|---------|--|
| True | The control engine performs a battery restart (FMR). |
| False | (default) No action is required. |

HardwareVersion property

This read-only property stores the version (revision level) of the control engine hardware.

Syntax:

[*value* =] *object*.HardwareVersion

The HardwareVersion property has these parts:

| Part | Description |
|---------------|--|
| <i>object</i> | The expression "object" refers to the Panel Control. |
| <i>value</i> | A string value that describes the hardware version for the control engine. |

mlfb property

This read only property stores the CPU 41x-2 PCI order number.

Syntax:

[*value* =] *object*.mlfb

The mlfb property has these parts:

| Part | Description |
|---------------|--|
| <i>object</i> | The expression "object" refers to the Panel Control. |
| <i>value</i> | A string value that specifies the order number for the control engine. |

ModeCtrl property

This property changes the operating mode of the control engine.

Syntax:

object.ModeCtrl [= *value*]

The ModeCtrl property has these parts:

| Part | Description |
|---------------|---|
| <i>object</i> | The expression "object" refers to the Panel Control. |
| <i>value</i> | An integer that determines the new operating mode for the control engine. |

The settings for the *value* are:

| Setting | Description |
|---------|-----------------------|
| 0 | MRES (memory restart) |
| 1 | STOP mode |
| 2 | RUN mode |
| 3 | RUN-P mode |

OnStateChanged method

This method is used internally by the control and must not be modified.

PSBattF property

This read-only property shows the state of the "Battery Fault" indicator on the control. This property is valid for the control engine. The BATTf indicator lights to alert the user to a battery fault condition.

Syntax:

[*value* =] *object*.PSBattF

The PSBattF property has these parts:

| Part | Description |
|---------------|---|
| <i>object</i> | The expression "object" refers to the Panel Control. |
| <i>value</i> | An integer expression that specifies the status of the BATTf indicator on the <i>object</i> . |

Settings for the *value* are shown in Table D-6.

PSOn property

This read-only property shows the state of the power supply (ON) display on the control. The ON display shows the status of the power supply for the control engine.

Syntax:

[*value* =] *object*.PSOn

| Part | Description |
|---------------|--|
| <i>object</i> | The expression "object" refers to the Panel Control. |
| <i>value</i> | An integer expression that specifies the status of the PS indicator on the <i>object</i> . |

Settings for the *value* are shown in Table D-6.

PwrSwitch property

This property indicates the on/off status of the control engine.

Syntax:

`object.PwrSwitch [= value]`

The PwrSwitch property has these parts:

| Part | Description |
|---------------|--|
| <i>object</i> | The expression "object" refers to the Panel Control. |
| <i>value</i> | A Boolean expression that specifies whether the control engine is enabled or disabled. |

The settings for the *value* are:

| Setting | Description |
|---------|---------------------------------|
| True | The control engine is enabled. |
| False | The control engine is disabled. |

ResourceFile property

This read-only property determines the name of the DLL for the language-specific strings displayed by the control.

Syntax:

`object.ResourceFile [= value]`

The ResourceFile property has these parts:

| Part | Description |
|---------------|--|
| <i>object</i> | The expression "object" refers to the Panel Control. |
| <i>value</i> | A string that determines the name for the language-specific DLL. |

ResourcePath property

This read-only property contains the pathname of the language-specific DLL selected for the control.

Syntax:

`object.ResourcePath [= value]`

The ResourcePath property has these parts:

| Part | Description |
|---------------|--|
| <i>object</i> | The expression "object" refers to the Panel Control. |
| <i>value</i> | A string that determines the pathname for the language-specific DLL. |

SecurityState property

This property determines the level of security in effect for the control:

- Panel Control handles security checking.
- Disables the security checking by the control. Your application performs all of the security. (See also the SwitchOK property.)

Syntax:

`object.SecurityState [= value]`

The SecurityState property has these parts:

| Part | Description |
|---------------|--|
| <i>object</i> | The expression "object" refers to the Panel Control. |
| <i>value</i> | An integer that determines the level of security for the <i>object</i> . |

The settings for the *value* are:

| Setting | Description |
|---------|--|
| 0 | Panel Control provides security checks. |
| 1 | The security checking performed by the control is disabled. Your application performs all of the security. (See also the SwitchOK property.) |

SetPassword property

If set to True, this property executes the "Set Password" function for changing the password in the control engine.

Syntax:

`object.SetPassword [= value]`

The SetPassword property has these parts:

| Part | Description |
|---------------|---|
| <i>object</i> | The expression "object" refers to the Panel Control. |
| <i>value</i> | A Boolean expression that determines whether to call the "Set Password" function. |

The settings for the *value* are:

| Setting | Description |
|---------|--|
| True | The control calls the "Set Password" function for changing the password in the control engine. |
| False | (default) No action. |

ShowErrorBoxes property

This property specifies whether to display the default error boxes when there is a user-generated error. Every time an error occurs, an Error event will be generated. If the ShowErrorBoxes property is enabled, a standard error message box will be displayed.

All errors on connections are reported by the Connection Error event.

Syntax:

object.ShowErrorBoxes [= *value*]

The ShowErrorBoxes property has these parts:

| Part | Description |
|---------------|---|
| <i>object</i> | The expression "object" refers to the Panel Control. |
| <i>value</i> | A Boolean expression that specifies whether the control displays error boxes. |

The settings for the *value* are:

| Setting | Description |
|---------|---|
| True | (default) The control shows standard error boxes. |
| False | The error boxes are hidden. |

SwitchOK property

If your application is handling the security (by disabling the security checking normally performed by the control), this property allows a requested action to be performed. When the SecurityState property is set to 3, the control waits until the SwitchOK property is set to True before performing any action requested by a user. If the SecurityState property is set to 4, this property must be set to "True" for any action to take place.

Syntax:

`object.SwitchOK [= value]`

The SwitchOK property has these parts:

| Part | Description |
|---------------|--|
| <i>object</i> | The expression "object" refers to the Panel Control. |
| <i>value</i> | A Boolean expression that allows or disallows an action to be performed. |

The settings for the *value* are:

| Setting | Description |
|---------|---|
| True | The user has permission to affect the requested action. The control then performs the requested action. |
| False | (default) The control does not perform the requested action. |

D.6 Events of the Panel Control

AlarmCondition event

This event occurs when the Panel Control detects that the control engine has an error condition or has gone to STOP mode.

Syntax: `AlarmCondition()`

ConnectionError event

This event occurs when an error on a connection occurs. The ConnectionError event provides no parameters.

Syntax:

`ConnectionError()`

MouseDown event

This event occurs when a mouse button is pressed while the mouse cursor is over the control.

Syntax:

```
MouseDown(short Button, short Shift, OLE_XPOS_PIXELS x, _
OLE_YPOS_PIXELS y)
```

The MouseDown event has these parts:

| Part | Description |
|---------------|--|
| <i>Button</i> | <p>An integer that identifies the button that was pressed to cause the event</p> <p>The button argument is a bit field with bits corresponding to the left button (bit 0), right button (bit 1), and middle button (bit 2). These bits are equivalent to the values 1, 2 and 4. Only one of the bits is set and consequently indicates which mouse button has triggered the event.</p> |
| <i>Shift</i> | <p>An integer that corresponds to the state of the SHIFT, CTRL, and ALT keys when the button specified in the button argument is pressed or released</p> <p>A bit is set if the key is down. The shift argument is a bit field with the least-significant bits corresponding to the SHIFT key (bit 0), the CTRL key (bit 1), and the ALT key (bit 2). These bits are equivalent to the values 1, 2 and 4. The "Shift" argument displays the state of these keys. Some, all, or none of the bits can be set, indicating that some, all, or none of the keys are pressed. For example, if both CTRL and ALT were pressed, the value of shift would be 6.</p> |
| <i>x,y</i> | <p>Returns a number that specifies the current location of the mouse pointer</p> |

MouseMove event

This event occurs when the mouse cursor moves over the control.

Syntax:

```
MouseMove(short Button, short Shift, OLE_XPOS_PIXELS x, OLE_YPOS_PIXELS y)
```

The MouseMove event has these parts:

| Part | Description |
|---------------|--|
| <i>Button</i> | <p>An integer that identifies the button that was pressed to cause the event</p> <p>The button argument is a bit field with bits corresponding to the left button (bit 0), right button (bit 1), and middle button (bit 2). These bits are equivalent to the values 1, 2 and 4. Only one of the bits is set and consequently indicates which mouse button has triggered the event.</p> |
| <i>Shift</i> | <p>An integer that corresponds to the state of the SHIFT, CTRL, and ALT keys when the button specified in the button argument is pressed or released</p> <p>A bit is set if the key is down. The shift argument is a bit field with the least-significant bits corresponding to the SHIFT key (bit 0), the CTRL key (bit 1), and the ALT key (bit 2). These bits are equivalent to the values 1, 2 and 4. The "Shift" argument displays the state of these keys. Some, all, or none of the bits can be set, indicating that some, all, or none of the keys are pressed. For example, if both CTRL and ALT were pressed, the value of shift would be 6.</p> |
| <i>x,y</i> | <p>Returns a number that specifies the current location of the mouse pointer</p> |

MouseUp event

This event occurs when a mouse button is released while the mouse cursor is over the control.

Syntax:

```
MouseUp(short Button, short Shift, OLE_XPOS_PIXELS x, _
OLE_YPOS_PIXELS y)
```

The MouseUp event has these parts:

| Part | Description |
|---------------|---|
| <i>Button</i> | An integer that identifies the button that was pressed to cause the event The button argument is a bit field with bits corresponding to the left button (bit 0), right button (bit 1), and middle button (bit 2). These bits are equivalent to the values 1, 2 and 4. Only one of the bits is set and consequently indicates which mouse button has triggered the event. |
| <i>Shift</i> | An integer that corresponds to the state of the SHIFT, CTRL, and ALT keys when the button specified in the button argument is pressed or released A bit is set if the key is down. The shift argument is a bit field with the least-significant bits corresponding to the SHIFT key (bit 0), the CTRL key (bit 1), and the ALT key (bit 2). These bits are equivalent to the values 1, 2 and 4. The "Shift" argument displays the state of these keys. Some, all, or none of the bits can be set, indicating that some, all, or none of the keys are pressed. For example, if both CTRL and ALT were pressed, the value of shift would be 6. |
| <i>x,y</i> | Returns a number that specifies the current location of the mouse pointer |

MResBttnSelected event

This event occurs when a user selects (clicks on) the memory reset (MRES) button on the Panel Control. You can use this event for implementing external security for your process.

Syntax: `MResBttnSelected()`

RunBttnSelected event

This event occurs when a user selects (clicks on) the RUN mode button on the Panel Control. You can use this event for implementing external security for your process.

Syntax: `RunBttnSelected()`

RunPBttSelected event

This event occurs when a user selects (clicks on) the RUN-P mode button on the Panel Control. You can use this event for implementing external security for your process.

Syntax: `RunPBttSelected()`

StopBttSelected event

This event occurs when a user selects (clicks on) the STOP mode button on the Panel Control. You can use this event for implementing external security for your process.

Syntax: `StopBttSelected()`

UpdateState event

This event occurs when the Panel Control detects a change in the status of the control engine.

Syntax: `UpdateState()`

Spare Parts and Accessories – Order Numbers



You will find further order numbers in the *ST 70 Catalog*.

| Spare Parts/Accessories | Order No. |
|--|---|
| CPU 412-2 PCI | 6ES7 612-2QH00-0AB4 |
| CPU 416-2 PCI | 6ES7 616-2QL00-0AB4 |
| PS extension board | 6ES7 678-1RA00-0XB0 |
| Lithium battery, 3.6 V | 6ES7 971-2BA00-0AA0 |
| Bus connector without a programming device socket | 6ES7 972-0BA40-0XA0/ 6GK1 500-0EA02 |
| Bus connector with a programming device socket | 6ES7 972-0BB40-0XA0 |
| Y-cable for 12 V voltage supply from the PC power supply unit to PS | C79459-A1490-B5 |
| Connector for connection of 24 V DC to PS extension board with 1.5 m cable | Fa. ODU Steckverbindingssysteme connector Mini Snap series S11B0C-L03MPH0-7000 |
| Battery holder | C79459-A1490-D11 |

Guidelines for Handling Electrostatic Sensitive Devices (ESD)

F

Introduction

In this appendix, we explain

- what is meant by “electrostatic sensitive devices”
- the precautions you must observe when handling and working with electrostatic sensitive devices.

In this chapter

This chapter contains the following sections on electrostatic sensitive devices:

| Section | Contents | Page |
|---------|--|------|
| F.1 | What are ESDs? | F-2 |
| F.2 | Electrostatic Charging of Persons | F-3 |
| F.3 | General Protective Measures against Electrostatic Discharge Damage | F-4 |

F.1 What are ESDs?

Definition

All electronic modules are equipped with large-scale integrated ICs or components. Due to their design, these electronic elements are very sensitive to overvoltages and thus to any electrostatic discharge.

Electrostatically Sensitive Devices are frequently referred to simply by the abbreviation ESD.

Electrostatic sensitive devices are identified by the following symbol:

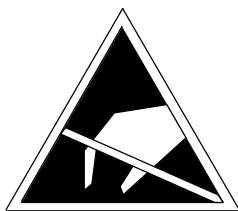

Caution

Electrostatic sensitive devices are subject to voltages that are far below the voltage values that can still be perceived by human beings. These voltages are present if you touch a component or the electrical connections of a module without previously being electrostatically discharged. In most cases, the damage caused by an overvoltage is not immediately noticeable and results in total damage only after a prolonged period of operation.

F.2 Electrostatic Charging of Persons

Charging

Every person with a non-conductive connection to the electrical potential of his/her surroundings can be charged electrostatically.

Figure F-1 shows you the maximum values for electrostatic voltages to which a person can be exposed by coming into contact with the materials indicated in the figure. These values conform to the specifications of IEC 801-2.

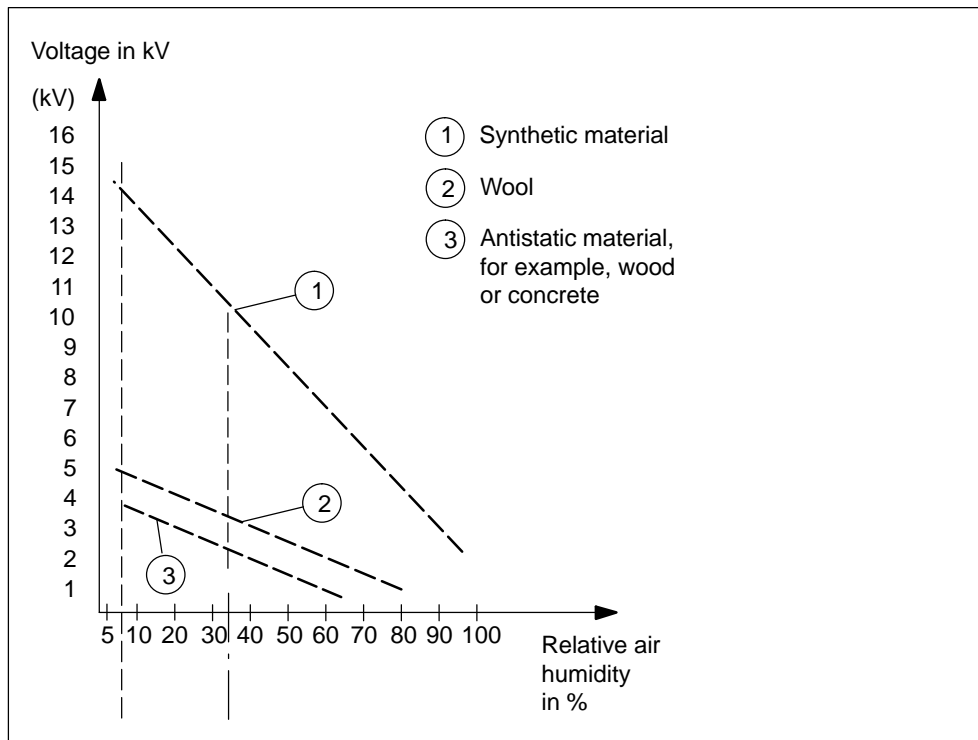

Figure F-1 Electrostatic Voltages which Can Build Up on a Person

F.3 General Protective Measures Against Electrostatic Discharge Damage

Ensure sufficient grounding

Make sure that the personnel, working surfaces and packaging are sufficiently grounded when handling electrostatic sensitive devices. You thus avoid electrostatic charging.

Before starting work on the PC, for example, touch the housing of the PC.

Avoid direct contact

You should touch electrostatic sensitive devices only if it is unavoidable (for example, during maintenance work). Hold modules without touching the pins of components or printed conductors. In this way, the discharged energy cannot affect the sensitive devices.

If you have to carry out measurements on a module, you must discharge your body before you start the measurement by touching grounded metallic parts. Use grounded measuring devices only.

G

List of Abbreviations

| Abbreviations | Description |
|---------------|--|
| CP | Communication processor |
| CPU | Central processing unit |
| DB | Data block |
| FB | Function block |
| FC | Function |
| FOC | Fiber-optic cable |
| FM | Function module |
| GD | Global data communication |
| LAD | Ladder logic (programming language representation in STEP 7) |
| IM | Interface module |
| M | Electrical bonding |
| MPI | Multipoint interface |
| OB | Organization block |
| OP | Operator panel |
| IP | Intelligent I/O |
| PG | Programming device |
| PII | Process image input table |
| PIQ | Process-image output table |
| PLC | Programmable logic controller |
| PS | Power supply |
| PZF | I/O access error |
| SFB | System function block |
| SFC | System function |
| SM | Signal module |
| STL | Statement list (programming language representation in STEP 7) |

Glossary

B

Backup battery

The backup battery ensures that the → user program in the → CPU is stored in the event of a power failure and that defined data areas and memory markers, timers and counters are retentive.

BIOS

Basic Input Output System

BIOS means that part of the software that establishes the connection between hardware and the operating system – for example, MS-DOS. This software is stored in an EPROM.

Important components are, for example, loaders for the operating system, the (hardware) Setup for establishing the hardware configuration and for setting the time.

Bus

A bus is a communication medium connecting several nodes. Data transmission can be serial or parallel across electrical conductors or fiber-optic cables.

C

Chassis ground

The chassis ground is the sum of all the interconnected inactive parts of a resource which cannot assume a hazardous contact voltage even in the event of a fault.

Clock

→ Timers

Cold restart

Complete restart of the programmable control system and its application after all the dynamic data (variables of the I/O image, internal registers, timers, counters, etc. and associated program parts) have been reset to a predefined value. A cold restart can be initiated automatically (for example, following a power failure, a loss of information in dynamic memory sections, etc.) or manually.

Communication processor

Communication processors are modules for point-to-point and bus links.

Configuration

Assignment of modules to racks/slots and (for example, for signal modules) addresses.

Configuring

By configuring we mean the grouping of individual modules to form an automation system.

Counter

Counters are component parts of the → CPU system memory. The contents of the "counter cells" can be modified by STEP 7 instructions (for example, count up/count down).

CPU

A central processing unit is the main processing unit of the automation system with a processor, arithmetic unit, memory, operating system and interface for the programming device.

D

Data block

Data blocks (DB) are parts of the user program that contain the program data. There are global data blocks, which can be accessed by all logic blocks, and there are instance data blocks, which are assigned to a specific FB call.

Data, static

Static data are data which can be used only within a function block. The data is saved in an instance data block belonging to the function block. The data stored in the instance data block is retained until the next time the function block is called.

Data, temporary

Temporary data are local data of a block which are stored in the L stack during execution of a block and which are no longer available after this block has been executed.

Default setting

The default setting is a useful basic setting which is always used when no other value is specified (assigned).

E

Electromagnetic compatibility

By electromagnetic compatibility we mean the ability of an electrically operated resource to operate in a specified environment without influencing that environment in an unauthorized manner.

Equidistance

Equidistance is a property of PROFIBUS-DP which ensures bus cycles of equal length. "Bus cycles of equal length" means that the DP master always begins the DP bus cycle after the same period of time. From the viewpoint of the connected DP slaves, this means that they similarly receive their data from the DP master in exactly equal intervals of time.

Equipotential bonding

Electrical connection (equipotential bonding conductor) which gives the bodies of electrical equipment and external conducting bodies the same or approximately the same potential, in order to prevent interference or dangerous voltages from being generated between these bodies.

Error handling using OB

If the operating system detects a specific error (for example, an access error with STEP 7), it calls the organization block (error OB) which is provided for this event and which specifies the subsequent behavior of the CPU.

Error indication

The error indication is one of the possible responses of the operating system to a → runtime error. The other possible reactions are: → error reaction in the user program, STOP mode of the CPU.

Error reaction

Reaction to a → runtime error. The operating system can respond in the following ways: conversion of the programmable controller to the STOP mode, call of an organization block in which the user can program a response or display of the error.

F

Flash EPROM

FEPROMs are the same as electrically erasable EEPROMS in that they can retain data in the event of a power failure, but they can be erased much more quickly (FEPROM = Flash Erasable Programmable Read Only Memory). They are used on → memory cards.

Function

A function (FC) in accordance with IEC 1131-3 a → logic block without → static data. A function offers the possibility of passing on parameters in the user program. In this way, functions are suitable for programming frequently recurring complex functions such as calculations.

Function block

A function block (FB) in accordance with IEC 1131-3 is a → logic block with → static data. An FB allows parameters to be passed in the user program. Function blocks are therefore suitable for programming complex functions, e.g. closed-loop controls, mode selections, which are repeated frequently.

G**Global data communication**

Shared data communication is a procedure used to transfer shared data between CPUs (without CFBs).

Ground

The conducting earth whose electric potential can be set equal to zero at any point.

In the vicinity of grounding electrodes, the earth can have a potential different to zero. The term “reference ground” is frequently used to describe these circumstances.

Ground, to

To ground means to connect an electrically conducting component to the grounding electrode (one or more conducting components which have a very good contact with the earth) across a grounding system.

H**Hardware**

Hardware is the name given to the complete physical and technical equipment of an automation system.

I

Interface, multipoint

→ MPI

Internetwork traffic

Internetwork communication is characterized by the fact that the PROFIBUS-DP nodes "listen in" to find out which data a DP slave is sending back to its DP master. Using this function the eavesdropper (receiver) can directly access changes in the input data of other DP slaves.

Interrupt

Interrupt is the name given to the interruption of program scanning in the processor by an externally queued event – for example, timer expired, data request, etc.

ISA bus

Abbreviation for "Industry Standard Architecture".

L

Load memory

The load memory is part of the CPU. It contains the objects generated by the programming device. It is implemented either as a plug-in memory card or a permanently integrated memory.

Local data

→ Data, temporary

Logic block

A logic block in SIMATIC S7 is a block which contains a section of the STEP 7 user program (as opposed to a → data block, which only contains data).

M

Memory card

Memory cards are memory media in smart card format for CPUs and CPs. They are implemented as → RAM or → Flash EPROM.

Memory markers

Memory markers are part of the → system memory of the CPU for storing interim results. They can be accessed bit by bit, byte by byte, word by word or double word by double word.

Mode

The SIMATIC S7 automation systems have the following operating states: STOP, → STARTUP, RUN.

Mode switch

The mode switch is used to set the mode you require on the CPU.

Module parameters

Module parameters are values which can be used to control the response of the module. A distinction is made between static and dynamic module parameters.

MPI

The multipoint interface (MPI) is the programming device interface of SIMATIC S7. It enables the simultaneous operation of several stations (programming devices, text displays, operator panels) on one or more CPUs. Each station is identified by a unique address (MPI address).

N

Nesting depth

One block can be called from another by means of a block call. Nesting depth is the number of →logic blocks called at the same time.

Network

In terms of communications, a network is the interconnection of several CPUs and other terminal – for example, a programming device – by means of connecting cables. Data exchange is performed between the connected devices.

Node address

The node number represents the "number" of a CPU or programming device or another intelligent I/O module when they can communicate with each other across a network. The node address is assigned with STEP 7 software.

Non-isolated

On non-isolated input/output modules, there is an electrical connection between the reference potentials of the control and load circuits.

O

Operating system of the CPU

The operating system of the CPU organizes all functions and processes of the CPU which are not associated with a special control task.

Optically isolated

On optically isolated I/O modules, the reference potentials of the control and load circuits are galvanically isolated, for example by optocoupler, relay contact or transformer. Input/output circuits can be connected to a common potential.

Organization block

Organization blocks (OBs) form the interface between the operating system of the S7-400 CPU and the user program. The processing sequence of the user program is defined in the organization blocks.

P

PCI bus

Abbreviation for “peripheral component interconnect bus”. The PCI bus is the standard bus on the AT-compatible PC.

PLC

→ Programmable logic controller

Process image

The process image is an integral part of the → system memory of the S7-400 CPU. The signal states of the input modules are written into the process-image input table at the start of the cyclic program. At the end of the cyclic program, the signal states in the process-image output table are transferred to the output modules.

PROFIBUS-DP

Using PROFIBUS-DP, you can set up a distributed I/O system. Digital and analog modules are transferred by the automation system to the process on site – and over a distance of up to 23 km at that (when using fiber-optic cables).

The digital and analog modules are connected to the automation system via the PROFIBUS-DP fieldbus and addressed in the same way as centralized I/Os.

PROFIBUS-DP conforms to the standard EN 50 170 Volume 2, PROFIBUS.

Programmable logic controller

Programmable logic controllers (PLCs) are electronic controllers whose function is saved as a program in the control unit. The configuration and wiring of the device therefore do not depend on the function of the controller. The programmable logic controller has the architecture of a computer; it consists of → CPU with memory, I/O modules and internal bus system. The I/O and the programming language are designed to meet the control engineering requirements.

Programming device

Programming devices are essentially personal computers which are compact, portable and suitable for industrial applications. They are equipped with special hardware and software for SIMATIC programmable controllers.

Protective ground

Connection to a common ground, using a protective conductor, for the accessible, conductive parts of the electrical resources which are not normally live but might become live in the event of a fault and which are jointly protected by a protective device.

R

RAM

A RAM (random access memory) is a semiconductor with random access.

Restart

With the S7: when the CPU starts up (for example, after operating the mode switch from STOP to RUN or when the mains voltage is ON), either organization block OB101 (Complete Restart) or organization block OB100 (Restart) is processed initially, followed by cyclic program processing (OB1). On a restart, the process-image input table is read in and the STEP 7 user program is executed starting with the first command in OB1.

Retentive data

Retentive data are not lost in the event of a line voltage failure if there is a backup battery.

Runtime error

Errors that occur during running of the user program in the automation system (in other words, not in the process).

S

Scan time

The scan time is the time the → CPU requires for processing (OB1) the → user program.

Shared data

Shared data are data which can be addressed from any logic block (FC, FB, OB). In detail, this refers to memory markers M, inputs I, outputs O, timers, counters and data blocks DB. Absolute or symbolic access can be made to global data.

Startup

STARTUP mode is activated on a transition from STOP mode to RUN mode. Can be initiated by the mode switch or, after POWER UP, by means of an operator input on the programming device.

STEP 7

Programming language for programming, configuring and assigning parameters to user programs for SIMATIC S7 PLCs.

System diagnostics

System diagnostics is the term used to describe the detection, evaluation and signaling of errors which occur within the automation system. Examples of such errors are programming errors or failures on modules. System errors can be indicated with LED displays or by STEP 7.

System function

A system function (SFC) is a function which is integrated in the operating system of the CPU → and which can be called in the STEP 7 user program as required.

System function block

A system function block (SFB) is a → function block which is integrated in the operating system of the CPU and which can be called in the STEP 7 user program as required.

System memory

The system memory is integrated on the CPU and implemented as RAM. The system memory includes the operand areas (for example, timers, counters, memory markers, etc.) as well as the data areas (for example, communication buffers) required internally by the → operating system.

T**Timers**

Timers are component parts of the → CPU system memory. The contents of the time cells are automatically updated asynchronously to the user program by the operating system. The exact function of the time cell (for example, on-delay) is defined with STEP 7 instructions and their processing triggered (for example, start).

Transmission rate

Rate of data transfer (bps)

U

Ungrounded

Without galvanic connection to ground.

User program

The SIMATIC system distinguishes between the → operating system of the CPU and user programs. User programs are created with the programming software → STEP 7 in the programming languages that are possible (LAD and STL) and stored in logic blocks. Data are stored in data blocks.

V

Version

Products having the same order number are distinguished by their version. The product version is incremented with each upwardly compatible function extension, production-related modification (use of new components) or bug fix.

W

Warm restart

Complete restart following a power failure, with a user-programmed record of dynamic data and a user program segment defined in the system. A warm restart is identified by setting a status bit or other suitable means which can be read by the application and indicate that the shutdown of the PLC system caused by the power failure has been detected in RUN mode.

Index

Numbers

3COM card, 1-3

A

Access aids, in manual, vi

Access error, 5-7

Access point configuration, example, time synchronization, 7-23

Access point setting, time synchronization, 7-5

Access protection, submenu, 5-21

Accessories, E-1

Acknowledgement error, 5-6

ActiveFilePath property, D-11

ActiveX controls, properties, Panel Control, D-5

Additional support, vi

Address area

 CPU 41x-2 PCI, 6-2

 reserved, 4-2, 8-11

AlarmCondition event, D-22

Applicability, of manual, iii

Applicable documents, how the manual fits in, v

Approvals, iv, A-1

Archive

 button, 5-17

 memory card file, 5-13

Area of application, A-2

Australia, approval, A-8

Autoload, 5-15

 submenu "Customize", 5-21

AutoStart property, D-11

B

Backup battery, Glossary-1

 connecting, 4-5

 installation, 2-14

 order number, E-1

 passivation layer removal, 4-6

 supplying, 2-15

 using, 4-5

BATF, 5-4

BATT., 2-15

Battery. See backup battery

Battery holder

 attaching to PC housing, 2-15

 for backup battery, 2-14

BF, 1-5

BIOS, Glossary-1

Bit memories, memory reset, D-4

Box PC 620, 1-2

Box PC 820, 1-2

Bus, Glossary-1

Bus cable

 installing on bus connectors with order number 6ES7 ... , B-18

 length of spur lines, B-13

Bus connector

 installing bus cable, B-18

 plugging into module, B-19

 purpose, B-17

 removing, B-20

 setting the terminating resistor, B-19

 terminating resistor, B-7

Bus segment. See segment

BUSF, 6-4, 6-15

BUSF1, 5-4

BUSF2, 5-4

C

Cable length, maximum, B-12

Cause of error, 5-7

CE, mark, A-2

Changes, from previous version of manual, iv

Changing the operating mode, D-3

 effects on status displays, D-3

 in STEP 7 and WinCC, D-3

 in STEP 7 or WinCC, D-3

Chassis ground, Glossary-1

Check list, 2-17

CheckPW property, D-11

Checks before initial power up, 2-17

Climatic environmental conditions, A-6

Clock failure, 5-6

- Cold restart, 5-9, Glossary-2
- Combi slot, 2-2
- Commissioning, approach, 4-2
- commissioning wizard, 7-11
- Communication error, 5-7
- Communication processor, Glossary-2
- Communications, configuration, B-2
- Complete restart, 5-9
 - memory reset, D-4
 - status displays, D-5
 - status indicators, D-4
- Component configurator, 7-11
- component configurator, 3-5
- Components
 - for MPI network, B-7
 - PROFIBUS-DP network, B-7
 - WinAC Slot 41x, 1-1
- Computing
 - Panel Control, properties, D-5–D-6
 - properties, Panel, D-5–D-6
- Configuration, Glossary-2
 - communications, B-2
 - of a PROFIBUS subnet, B-1
 - of an MPI subnet, B-1
 - WinAC Slot 41x, 1-1
- Configuration frame. See on Internet at <http://www.ad.siemens.de/simatic-cs>
- Configuring, Glossary-2
- ConnectCPU property, D-12
- ConnectionError event, D-22
- Control engine
 - setting in Panel Control, D-5
 - SIMATIC controls, panel, D-1
- Control panel, 5-2
 - installation, 5-2
 - LED displays, 5-4
- ControlEngine property, D-12
- Controls
 - control panel, 5-3
 - menu bar of CPU 41x-2 PCI, 5-16
- Controls and display elements, 5-3
- Counter, Glossary-2
- Counters, memory reset, D-4
- CP, G-1
- CP 1613, 1-3
- CP 5613, 1-3
- CPU, G-1, Glossary-2
 - menu, 5-18
- CPU 412-2 PCI, 1-2
 - technical specifications, 8-3
- CPU 416-2 PCI, 1-2
 - technical specifications, 8-7
- CPU 41x-2 PCI
 - battery supply, C-2
 - bus interruption, 6-8, 6-20, 6-30
 - compatibilities, 8-11
 - diagnostics addresses for PROFIBUS, 6-7, 6-19
 - differences from previous version, 8-11
 - direct data exchange, 6-29
 - DP address areas, 6-2
 - DP master, 6-3
 - diagnostics by LEDs, 6-4
 - diagnostics with STEP 7, 6-5
 - DP services, C-6
 - DP slave, 6-9
 - diagnostics, 6-14
 - diagnostics by means of LEDs, 6-15
 - diagnostics with STEP 7, 6-16
 - installation, 2-2
 - interfaces, 1-4
 - operating state changes, 6-8, 6-20, 6-30
 - operation without memory card, C-5
 - order number, E-1
 - parameters, 8-2
 - reset, 4-8
 - resetting, 4-4, 4-8
 - startup response after PC power up, 2-8
 - transfer memory, 6-10
- CPU connection, submenu, 5-23
- CPU Panel Control
 - button, D-4
 - memory reset, D-4
 - RUN mode
 - status display, D-5
 - status indicator, D-4
 - status indicators, restart, D-4
 - STOP mode, status indicator, D-4
 - system error (SF), D-5
 - system fault (SF) indicator, D-4
- CpuExtF property, D-13
- CpuFrce property, D-14
- CpuIntF property, D-14
- CpuRun property, D-14
- CpuRunning property, D-15
- CpuStop value, D-15
- CSA approval, A-2
- Customize, submenu, 5-19

D

Data

- SIMATIC controls, panel, D-5–D-6
- static, Glossary-3
- temporary, Glossary-3

Data block, Glossary-3

Data exchange, direct, 6-29

DB, G-1

Default setting, Glossary-3

Defective CD, errors during installation, 3-4

Device. *See* node

Device-related diagnostics, CPU 41x-2 PCI as DP slave, 6-26

Diagnostic buffer, 5-7

- after memory reset, D-4

Diagnostic interrupt, 5-6

- CPU 41x-2 PCI as DP slave, 6-27

Diagnostics

- CPU 41x-2 PCI as DP slave, 6-14
- device-related, CPU 41x-2 PCI as slave, 6-26

Direct Data Exchange, 6-30

- identifier-related, CPU 41x-2 PCI as DP slave, 6-25

Diagnostics addresses, CPU 41x-2 PCI, 6-7, 6-19

Direct Data Exchange, diagnostics, 6-30

Direct data exchange, CPU 41x-2 PCI, 6-29

Display elements, control panel, 5-3

Disturbance variables

- pulse-shaped, A-3
- sinusoidal, A-4

Documentation, on Internet, vi

Downloading a program to CPU 41x-2 PCI allowed in RUN-P mode or STOP mode, D-3

- not allowed in RUN mode, D-3

DP master

- CPU 41x-2 PCI, 6-3
- diagnostics by LEDs, 6-4
- diagnostics with STEP 7, 6-5

DP slave

- CPU 41x-2 PCI, 6-9
- diagnostics by means of LEDs, 6-15
- diagnostics with STEP 7, 6-16

DP slave diagnostics, structure, 6-21

E

Electromagnetic compatibility, A-3, Glossary-3

Entering station names, 7-11

entering station names, 3-5

Environmental conditions, mechanical, A-6

Equidistance, C-6, Glossary-3

Equipotential bonding, Glossary-4

Error display, 5-5

Error handling, using OB, Glossary-4

Error indication, Glossary-4

Error messages, 5-6

Error reaction, Glossary-4

ESD guideline, F-1

Essential basic skills, iii

Events

- AlarmCondition, D-22
- ConnectionError, D-22
- MouseDown, D-23
- MouseMove, D-24
- MouseUp, D-25
- MResBttnSelected, D-25
- RunBttnSelected, D-25
- RunPBttnSelected, D-26
- StopBttnSelected, D-26
- UpdateState, D-26

Example

- Panel Control programs, D-6
- time synchronization, 7-10

Exit, button, 5-17

External 24 V DC, requirements, 2-12

External battery supply, 2-15

External voltage supply, requirements, 2-12

EXTF, 5-4

F

Failure of a station, 5-7
 Fan, connecting, 2-13
 FAQ
 access to process data, C-15
 backing up user data without PS extension board, C-4
 battery supply, C-2
 Box PC 620, C-15
 CPU 41x-2 PCI as DP slave, C-6
 DP services, C-6
 equidistance, C-6
 FLASH card, RAM card, C-5
 Industrial Ethernet-interface, C-7
 operation without memory card, C-5
 PCI, C-14
 ProTool/Pro, C-8
 PS extension board and Y-cable, C-4
 routing, C-7
 usage without PS extension board, C-3
 user data backup after power off/on, C-4
 using the PS extension board, C-2
 WinCC, C-12
 FB, G-1
 FC, G-1
 File, menu, 5-17
 FirmwareVersion property, D-16
 FLASH card, 10-2
 usage, C-5
 Flash EPROM, Glossary-4
 FM, G-1
 FMR, button, 5-19
 FmrSwitch property, D-16
 FOC, G-1
 FRCE, 5-4
 Function, Glossary-4
 Function block, Glossary-5

G

GB, G-1
 General, submenu "Customize", control panel, 5-19
 General technical specifications, A-1
 Getting started, time synchronization, 7-10
 Ground, Glossary-5
 Grounded operation, RS 485 repeater, B-23
 Guide, through manual, vi
 Guideline, ESD, F-1
 Guidelines, MRES (memory reset), D-2

H

Hardware, Glossary-5
 configuration, 4-1
 HardwareVersion property, D-17
 Help, menu, 5-23
 Highest MPI address, B-4

I

I/O access error, 8-11
 See also access error
 Identifier-related diagnostics, CPU 41x-2 PCI as DP slave, 6-25
 IM, G-1
 Index, 3-4
 -component configurator, 3-4
 component configurator, 7-11
 Industrial Ethernet, connection, B-1
 Industrial Ethernet interface, S7 driver, C-7
 Installation
 control panel, 5-2
 CPU 41x-2 PCI, 2-2
 errors during installation, 3-4
 PS extension board, 2-2
 requirements, 2-2, 3-1
 WinAC Slot 41x, 3-1
 Insufficient memory, errors during installation, 3-4
 Interface
 CPU interfaces, 1-4
 multipoint, Glossary-6
 PS extension board, 1-6
 Interface error, 5-6
 Interface parameter assignment, time synchronization, 7-6
 Internetwork communication, Glossary-6
 See also direct data exchange
 Interrupt, Glossary-6
 Interrupts, CPU 41x-2 PCI as DP slave, 6-28
 INTF, 5-4
 IP, G-1
 ISA bus, Glossary-6

L

LAD, G-1
 Language, submenu "Customize", 5-20
 LED displays, control panel, 5-4
 LEDs, CPU 41x-2 PCI, 1-5

- Lithium battery. See backup battery
- Load memory, 5-11, Glossary-6
 - structure, 5-12
- Loading a program from a controller, allowed in RUN-P or STOP mode, D-3
- Loading a program from CPU 41x-2 PCI, not allowed in RUN mode, D-3
- Loading a program from the 41x-2 PCI, allowed in RUN-P or STOP operating mode, D-3
- Local data, Glossary-6
- Logic block, Glossary-6

- M**
- M, G-1
- Manual, applicability, iii
- Manufacturer's ID, CPU 41x-2 PCI as DP slave, 6-24
- Master PROFIBUS address, 6-24
- MC7 code error, 5-7
- Mechanical environmental conditions, A-6
- Memory area, memory reset, D-4
- Memory area of bit memories (M), memory reset, D-4
- Memory card, 1-2, Glossary-7
 - changing, 10-4
 - configuration, 10-1
 - function, 10-1
 - technical specifications, 10-5
- Memory card file
 - application, 5-12
 - Definition, 5-12
- Memory markers, Glossary-7
- Memory reset, MPI parameters, 4-5
- Memory reset (MRES), D-2
- Menu
 - "Access rights", 5-21
 - "Connect CPU", 5-23
 - "CPU", 5-18
 - "Customize", 5-19
 - "File", 5-17
 - "Safety", 5-21
- Menu bar, controls, 5-16
- Method called OnStateChanged, D-18
- Minimize, button, 5-17
- mlfb property, D-17
- Mode
 - RUN (controller), status display, D-5
 - STOP, status display, D-5
- Mode switch, D-2, Glossary-7
 - See *also* mode selector
- ModeCtrl property, D-17
- Module parameters, Glossary-7
- Module state, 4-1
- Monitoring functions, 5-6
- MouseDown event, D-23
- MouseMove event, D-24
- MouseUp event, D-25
- MPI, G-1, Glossary-7
 - address after memory reset, D-4
- MPI address, B-4
 - recommendation, B-6
 - rules, B-4
- MPI addresses, highest, B-4
- MPI interface, 1-4
 - as DP interface, 1-4
- MPI network, components, B-7
- MPI subnet
 - configuration, B-1
 - configuration example, B-9
 - configuration rules, B-5
 - data packets on, B-6
 - example of configuration, B-11
 - segment, B-12
- MPI/PROFIBUS-DP interface, 1-4
- MRES
 - button, 5-18
 - operating mode control, 5-8
- MRES (memory reset), D-2–D-4
- MResBtnSelected event, D-25

- N**
- Name, 3-5
 - component configurator, 7-11
- name, -component configurator, 3-4
- Nesting depth, Glossary-8
- Network, Glossary-8
- Networks, B-1
- New features, compared to previous version of manual, iv
- Node, B-3
- Node address, Glossary-8
- Nodes
 - connectable, B-3
 - number, B-3
- Non-isolated, Glossary-8

- O**
- OB, G-1
- ON, 5-4

- OnStateChanged method, D-18
 - OP, G-1
 - Operating conditions, A-6
 - Operating mode, Glossary-7
 - RUN (controller), D-3
 - RUN-P (controller), D-3
 - loading from CPU and loading into CPU allowed, D-3
 - STOP, D-3
 - loading from CPU and loading into CPU allowed, D-3
 - memory reset in STEP 7, D-4
 - Operating mode controls, 5-8
 - Operating modes, D-2, D-3
 - Operating system, CPU, Glossary-8
 - Operation list, iv
 - Optically isolated, Glossary-8
 - Options, button, 5-19
 - Order number, E-1
 - location, 1-3
 - Order of installation, 3-2
 - Organization block, Glossary-8
- P**
- Panel Control, D-1–D-12
 - events
 - AlarmCondition, D-22
 - ConnectionError, D-22
 - MouseDown, D-23
 - MouseMove, D-24
 - MouseUp, D-25
 - MResBttnSelected, D-25
 - RunBttnSelected, D-25
 - RunPBttnSelected, D-26
 - StopBttnSelected, D-26
 - UpdateState, D-26
 - operating modes, D-3
 - properties, D-5–D-6
 - ActiveFilePath, D-11
 - AutoStart, D-11
 - CheckPW, D-11
 - ConnectCPU, D-12
 - ControlEngine, D-12
 - CpuBusf1, CpuBusf2, D-13
 - CpuExtF, D-13
 - CpuFrce, D-14
 - CpuIntF, D-14
 - CpuRun, D-14
 - CpuRunning, D-15
 - CpuStop, D-15
 - FirmwareVersion, D-16
 - FmrSwitch, D-16
 - HardwareVersion, D-17
 - LED displays, D-10
 - mlfb, D-17
 - ModeCtrl, D-17
 - OnStateChanged method, D-18
 - operating modes of CPU, D-10
 - PSBattF, D-18
 - PSOn, D-18
 - PwrSwitch, D-19
 - ResourceFile, D-19
 - ResourcePath, D-19
 - SecurityState, D-20
 - SetPassword, D-20
 - ShowErrorBoxes, D-21
 - SwitchOK, D-22
 - restart, status display, D-5
 - sample programs, D-6
 - setting the control engine, D-5
 - status display, restart, D-5
 - status displays, D-5
 - STOP mode, status display, D-5
 - Panel PC 670, 1-2
 - Panel PC FI 45, 1-2
 - parameter assignment, component configurator, 3-4
 - Parameter assignment frame. See on Internet at <http://www.ad.siemens.de/simatic-cs>
 - Parameter assignment tool, 8-2
 - Passivation layer, 4-6
 - Password, 5-21
 - PC, 1-2
 - PCI, advantages, C-14
 - PCI bus, Glossary-9
 - PCI/ISA combi slot, 2-2
 - Performance features
 - CPU 412-2 PCI, 8-3
 - CPU 416-2 PCI, 8-7
 - Period, time synchronization, 7-9
 - Periphery access error, G-1
 - PG, 1-2, G-1
 - PII, G-1
 - PIQ, G-1
 - PLC, G-1, Glossary-9
 - Plug and remove interrupt, 5-6
 - Plug in card. See memory card
 - Power OFF, button, 5-18
 - Power ON, button, 5-18
 - Power supply unit fault, 5-6
 - Power up, 2-17
 - Priority class error, 5-7

- Procedures
 - change the operating mode, D-3
 - reset the memory areas, D-5
 - Process data, SIMATIC controls, panel, D-5
 - Process image, Glossary-9
 - Process interrupt, CPU 41x-2 PCI as DP slave, 6-27
 - Product note, 4-3
 - PROFIBUS address, B-4
 - PROFIBUS addresses, recommendation, B-6
 - PROFIBUS bus cable, B-15
 - properties, B-16
 - PROFIBUS network
 - components, B-7
 - connection, B-1
 - PROFIBUS subnet
 - configuration, B-1
 - example of configuration, B-10, B-11
 - segment, B-12
 - PROFIBUS-DP, Glossary-9
 - commissioning, B-25
 - equidistance, C-6
 - PROFIBUS-DP bus cables, rules for laying, B-16
 - PROFIBUS-DP subnet, configuration rules, B-5
 - Programmable logic controller, Glossary-9
 - Programming device, 1-2, Glossary-9
 - Programming device cable, 1-2
 - Programming error, 5-7
 - Project creation, example, time
 - synchronization, 7-14
 - Properties
 - ActiveFilePath, D-11
 - AutoStart, D-11
 - CheckPW, D-11
 - ConnectCPU, D-12
 - ControlEngine, D-12
 - CpuBusf1, CpuBusf2, D-13
 - CpuExtF, D-13
 - CpuFrce, D-14
 - CpuIntF, D-14
 - CpuRun, D-14
 - CpuRunning, D-15
 - CpuStop, D-15
 - FirmwareVersion, D-16
 - FmrSwitch, D-16
 - HardwareVersion, D-17
 - mIb, D-17
 - ModeCtrl, D-17
 - OnStateChanged method, D-18
 - Panel Control, D-5–D-6, D-10
 - PSBattF, D-18
 - PSOn, D-18
 - PwrSwitch, D-19
 - ResourceFile, D-19
 - ResourcePath, D-19
 - SecurityState, D-20
 - SetPassword, D-20
 - ShowErrorBoxes, D-21
 - SwitchOK, D-22
 - Protection level, setting, 5-10
 - Protection levels, 5-10
 - Protective ground, Glossary-10
 - PS, G-1
 - PS extension board, 1-2
 - cable connectors, 2-10
 - connecting a fan, 2-13
 - function, 9-1
 - installation, 2-2
 - interface, 1-6
 - order number, E-1
 - technical specifications, 9-2
 - usage, C-2
 - usage without PS extension board, C-3
 - Y-cable, C-4
 - PSBattF property, D-18
 - PSOn property, D-18
 - Pulse-shaped disturbance variables, A-3
 - Purpose of manual, iii
 - PwrSwitch property, D-19
- R**
- R, 1-5
 - Rack PC 830, 1-2
 - Rack PC RI 45, 1-2
 - Radial line, B-5
 - Radio interference, emission of, A-4
 - RAM, Glossary-10
 - RAM card, 10-2
 - usage, C-5
 - Readme file, 4-3
 - Requirements
 - for external voltage supply, 2-12
 - installation, 3-1
 - Reserved address area, 4-2

- Reset, CPU 41x-2 PCI, 4-4, 4-8
- Reset button, 4-8
- Resetting, with mode selection switch, 4-4
- ResourceFile property, D-19
- ResourcePath property, D-19
- Restart, Glossary-10
 - See also warm restart (restart)
 - memory reset, D-4
 - status displays, D-5
 - status indicators, D-4
- Restore
 - button, 5-17
 - memory card file, 5-14
- Retentive data, Glossary-10
 - memory reset, D-4
- Routing, 8-11
- RS 485 repeater, 1-3, B-5, B-21
 - appearance, B-20
 - connecting the PROFIBUS-DP bus cable, B-22
 - grounded operation, B-23
 - pin assignment for PG/OP socket, B-24
 - rules, B-21
 - technical specifications, B-24
 - terminating resistor, B-7
 - ungrounded operation, B-23
 - wiring the power supply, B-21
- Rules, for the configuration of a subnet, B-5
- RUN, 5-4
 - button, 5-18
 - operating mode control, 5-8
- RUN-P
 - button, 5-18
 - operating mode control, 5-8
- RunBttnSelected event, D-25
- RunPBttnSelected event, D-26
- Runtime error, Glossary-10

- S**
- S, 1-5
- Safety, submenu, 5-21
- Scan time, Glossary-10
- SecurityState property, D-20
- Segment, B-3
 - MPI subnet, B-12
 - PROFIBUS subnet, B-12
- Selecting the operating mode, D-3
- Service, on Internet, vii
- Service and support, viii

- Set PG/PC Interface
 - button, 5-19
 - time synchronization, 7-5
- SetPassword property, D-20
- Setup feature, 3-1
- SF, 1-5
 - See also system error (SF)
- SFB, G-1
- SFC, G-1
- Shared data, Glossary-10
- Shared data communication, Glossary-5
- Shipping and storage conditions, A-4
- ShowErrorBoxes property, D-21
- SIMATIC controls, Panel Control, D-1
- SIMATIC NET components, 1-3
- Sinusoidal disturbance variables, A-4
- Slot plate, LEDs, 1-5
- SM, G-1
- Software, special notes, 4-1
- Spare parts, E-1
- Spur line, length, B-13
- Standards, iv, A-1
- STARTUP, Glossary-11
- Startup response, CPU 41x-2 PCI, 2-8
- Startup type selection, 5-9
- Station name, component configurator, 7-11
- station name, -component configurator, 3-4
- Stations status 1 to 3, 6-22
- Status displays, 5-5, D-2–D-4, D-5
 - complete restart, D-5
- STEP 7, Glossary-11
 - hardware configuration, 4-1
 - user program memory, 5-12
- STEP 7 user program, load, 5-12
- STL, G-1
- STOP, 5-4
 - button, 5-18
 - operating mode control, 5-8
- StopBttnSelected event, D-26
- Submenu
 - "Connect CPU", 5-23
 - "Customize", 5-19
- Support, additional, vi
- Support and service, viii
- Support on Internet, vii
- Surge impedance. See terminating resistor
- Switch for inhibiting battery monitoring, 2-3
- SwitchOK property, D-22
- Symbolic name assignment, 8-11
- System diagnostics, Glossary-11

System error (SF), D-5
 System function, Glossary-11
 System function block, Glossary-11
 System memory, Glossary-11
 System requirements, 3-1

T

Technical specifications
 CPU 412-2 PCI, 8-3
 CPU 416-2 PCI, 8-7
 general, A-1
 memory card, 10-5
 PS extension board, 9-2
 RS 485 repeater, B-24
 Technological application, 4-2, 8-11
 Terminating resistor, B-6, B-7
 at bus connector, B-7
 at RS 485 repeater, B-7
 example, B-8
 setting on the bus connector, B-19
 Test environment, A-2
 Time synchronization, 7-1, 7-2
 access point configuration, example, 7-23
 assigning interface parameters, 7-6
 creating a project, example, 7-14
 example, 7-10
 getting started, 7-10
 period, 7-9
 set PG/PC interface, 7-5
 starting, example, 7-24
 user example, 7-10
 using, 7-8
 Time synchronization service, setting the
 access point, 7-5
 Timer, Glossary-1
 Timer error, 5-6
 Timers, Glossary-11
 memory reset, D-4
 Training center, vi
 Transfer memory
 CPU 41x-2 PCI, 6-10
 for data transfer, 6-10
 Transmission rate, B-3, Glossary-12
 Type, component configurator, 7-11

type, component configurator, 3-4

U

UL approval, A-2
 Ungrounded, Glossary-12
 Ungrounded operation, RS 485 repeater, B-23
 Uninstall
 WinAC Basis, 3-2
 WinAC Pro, 3-2
 WinAC Slot 41x, 3-6
 UpdateState event, D-26
 User example, time synchronization, 7-10
 User program, Glossary-12

V

Version, Glossary-12
 location, 1-3

W

Warm restart, Glossary-12
 Warm restart (restart), 5-9
 Warnings, MRES (memory reset), D-2
 WinAC Basis, uninstalling, 3-2
 WinAC Pro, uninstalling, 3-2
 WinAC Slot 412. See WinAC Slot 41x
 WinAC Slot 416. See WinAC Slot 41x
 WinAC Slot 41x
 access to process data, C-15
 advantages of using SIMATIC Box PC 620,
 C-15
 components, 1-1
 configuration, 1-1
 connection of ProTool/Pro, C-8
 installation, 3-1
 network routing, C-7
 operation as DP slave, C-6
 software, 3-1
 uninstall, 3-6
 uninstalling, 3-6
 WinCC application, C-12
 WinACTimeSync. See time synchronization
 Work memory, 5-11

