



Allen-Bradley

**SLC 500™ Fixed
Hardware Style**

**(Cat. No. 1747-L20, 1747-L30,
and 1747-L40 Processors)**

product icon

Installation and Operation Manual



Allen-Bradley

***SLC 500™ Fixed
Hardware Style***

***(Cat. No. 1747-L20, 1747-L30,
and 1747-L40 Processors)***

**Installation and
Operation Manual**

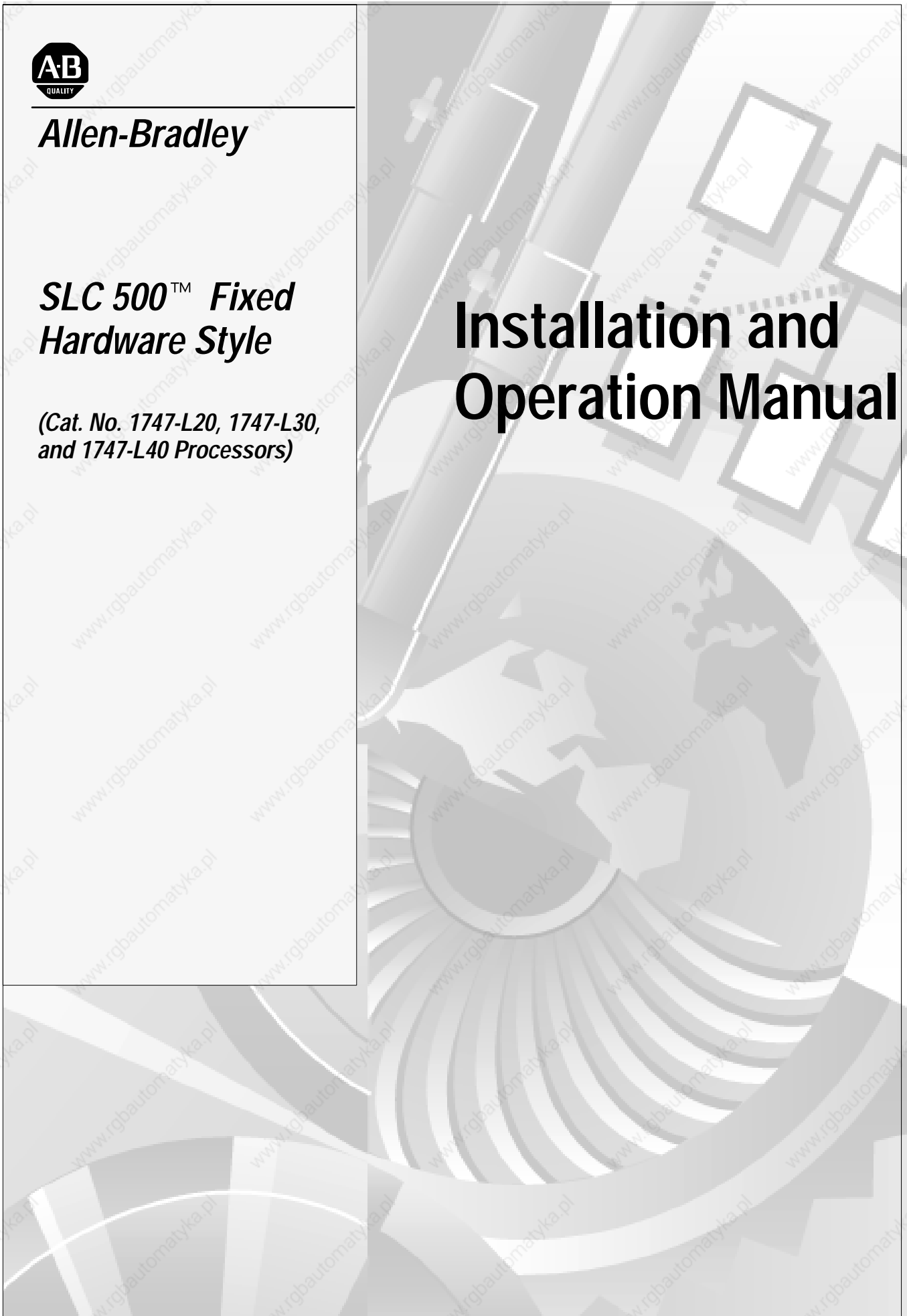

Important User Information

Solid state equipment has operational characteristics differing from those of electromechanical equipment. “Safety Guidelines for the Application, Installation and Maintenance of Solid State Controls” (Publication SGI-1.1) describes some important differences between solid state equipment and hard-wired electromechanical devices. Because of this difference, and also because of the wide variety of uses for solid state equipment, all persons responsible for applying this equipment must satisfy themselves that each intended application of this equipment is acceptable.

In no event will the Allen-Bradley Company be responsible or liable for indirect or consequential damages resulting from the use or application of this equipment.

The examples and diagrams in this manual are included solely for illustrative purposes. Because of the many variables and requirements associated with any particular installation, the Allen-Bradley Company cannot assume responsibility or liability for actual use based on the examples and diagrams.

No patent liability is assumed by Allen-Bradley Company with respect to use of information, circuits, equipment, or software described in this manual.

Reproduction of the contents of this manual, in whole or in part, without written permission of the Allen-Bradley Company is prohibited.

Throughout this manual we use notes to make you aware of safety considerations.



ATTENTION: Identifies information about practices or circumstances that can lead to personal injury or death, property damage, or economic loss.

Attentions help you:

- identify a hazard
- avoid the hazard
- recognize the consequences

Important: Identifies information that is especially important for successful application and understanding of the product.

PLC and PLC 5 are registered trademarks of Allen-Bradley Company, Inc.
SLC, SLC 500, Dataliner, and DTAM are trademarks of Allen-Bradley Company, Inc.
IBM is a registered trademark of International Business Machines, Incorporated.
Tandy is a trademark of the Tandy Corporation.
Gateway 2000 is a trademark of Gateway 2000, Inc.
Toshiba is a trademark of Toshiba America, Inc.
Compaq is a registered trademark of Compaq Computer Corporation.
Deskpro is a trademark of Compaq Computer Corporation.

Summary of Changes

The information below summarizes the changes to this manual since the last printing as 1747-NI001 in November, 1993.

To help you find new information and updated information in this release of the manual, we have included change bars as shown to the right of this paragraph.

New Information

The table below lists sections that document new features and additional information about existing features, and shows where to find this new information.

For This New Information	See
Updated list of related publications	Preface
High voltage warning	Chapters 2, 4, and 7

Table of Contents

Summary of Changes	<u>i</u>
New Information	<u>i</u>
Preface	<u>P-1</u>
Who Should Use this Manual	<u>P-1</u>
How to Use this Manual	<u>P-2</u>
Related Publications	<u>P-3</u>
Related Publications	<u>P-3</u>
Conventions Used in this Manual	<u>P-4</u>
Allen-Bradley Support	<u>P-4</u>
Local Product Support	<u>P-4</u>
Technical Product Assistance	<u>P-4</u>
Your Questions or Comments on this Manual	<u>P-4</u>
Selecting Your Hardware Components	<u>1-1</u>
What Your SLC 500 Controller Can Do for You	<u>1-1</u>
Overview of Your Fixed Control System	<u>1-2</u>
Fixed Controller Specifications	<u>1-3</u>
Memory Backup for the SLC 500 Fixed Controller	<u>1-4</u>
Configuration Options	<u>1-5</u>
Input Specifications	<u>1-6</u>
Output Specifications	<u>1-7</u>
Relay Contact Ratings	<u>1-8</u>
Selecting the 2-Slot Chassis	<u>1-8</u>
Selecting Discrete I/O Modules	<u>1-8</u>
Selecting Speciality I/O Modules	<u>1-8</u>
Selecting Enclosures	<u>1-9</u>
Selecting Operator Interfaces	<u>1-9</u>
Programming with a Hand-Held Terminal (1747-PT1)	<u>1-9</u>
Programming with Advanced Programming Software (APS) on an IBM Compatible Computer	<u>1-9</u>
Advanced Programming Software, 1747-PA2E	<u>1-10</u>
DH-485 Interface Converter (1747-PIC)	<u>1-10</u>
Monitoring with a Data Table Access Module (1747-DTAM-E) ..	<u>1-10</u>
EEPROM and UVPRM Memory Modules	<u>1-11</u>
Selecting Isolation Transformers	<u>1-12</u>
Special Considerations	<u>1-13</u>
Excessive Line Voltage Variations	<u>1-13</u>
Excessive Noise	<u>1-13</u>
Selecting Surge Suppressors	<u>1-14</u>
Selecting Contact Protection	<u>1-16</u>
Transistor Output Transient Pulses	<u>1-17</u>

Example	1-19
System Installation Recommendations	2-1
Typical Installation	2-1
Spacing Your Components	2-2
Preventing Excessive Heat	2-2
Grounding Guidelines	2-3
Master Control Relay	2-5
Emergency-Stop Switches	2-6
Power Considerations	2-7
Common Power Source	2-7
Loss of Power Source	2-7
Input States on Power Down	2-7
Other Types of Line Conditions	2-7
Safety Considerations	2-8
High Voltages – SLC 500 Fixed Hardware Style Controller (Series C) (Applies to 1747-L20A, -L30A, -L40A, -L20C, -L30C, and -L40C controllers)	2-8
Disconnecting Main Power	2-8
Wiring Safety Circuits	2-9
Distributing Power	2-9
Testing the Master Control Relay Circuit	2-9
Preventive Maintenance	2-9
Mounting Your SLC 500 Control System	3-1
Mounting Fixed Hardware Style Units	3-1
20 I/O Fixed ControllerÀ	3-2
30 and 40 I/O Fixed ControllerÀ	3-3
2-Slot Expansion ChassisÀ	3-4
Link Coupler (AIC)À	3-5
Data Table Access Module (DTAM)À	3-5
Installing Your Hardware Components	4-1
Mounting the 2-Slot Expansion Chassis	4-1
Installing I/O and Speciality Modules	4-2
Installing Your Memory Module	4-4
Removing Your Memory Module	4-5
Using the High-Speed Counter	4-5
High-Speed Counter Operation	4-5
High-Speed Counter Input Compatibility	4-6
Wiring Diagram of a High-Speed Counter Sinking Input Circuit ..	4-7
Wiring Diagram of a High-Speed Counter Sourcing Input Circuit ..	4-7

Wiring Your Control System	<u>5-1</u>
Defining Sinking and Sourcing	<u>5-1</u>
Contact Output Circuits — AC or DC	<u>5-2</u>
Solid-State DC I/O Circuits	<u>5-2</u>
Sourcing Device with Sinking Input Module Circuit	<u>5-2</u>
Sinking Device with Sourcing Input Module Circuit	<u>5-3</u>
Sinking Device with Sourcing Output Module Circuit	<u>5-3</u>
Sourcing Device with Sinking Output Module Circuit	<u>5-3</u>
Preparing Your Wiring Layout	<u>5-4</u>
Features of an I/O Module	<u>5-5</u>
Recommendations for Wiring I/O Devices	<u>5-6</u>
Wiring Your I/O Modules	<u>5-7</u>
Using Removable Terminal Blocks (RTBs)	<u>5-8</u>
Removing RTBs	<u>5-8</u>
Installing RTBs	<u>5-9</u>
Starting Up Your Control System	<u>6-1</u>
Procedures for Starting Up the Control System	<u>6-1</u>
1. Inspect Your Installation	<u>6-2</u>
2. Disconnect Motion-causing Devices	<u>6-2</u>
3. Initialize and Test Your Processor	<u>6-3</u>
4. Test Your Inputs	<u>6-4</u>
Input Troubleshooting Steps	<u>6-5</u>
5. Test Your Outputs	<u>6-6</u>
Output Troubleshooting Steps	<u>6-7</u>
6. Enter and Test Your Program	<u>6-8</u>
7. Observe Control Motion	<u>6-10</u>
8. Conduct a Dry Run	<u>6-11</u>
Maintaining Your Control System	<u>7-1</u>
Handling, Storing, and Transporting Battery, Catalog Number 1747-BA	<u>7-1</u>
Handling	<u>7-1</u>
Storing	<u>7-1</u>
Transporting	<u>7-2</u>
Installing or Replacing Your SLC 500 Battery	<u>7-4</u>
Replacing the Power Supply Fuse	<u>7-5</u>
Replacing Retainer Clips on an I/O Module	<u>7-6</u>
Removing Damaged Retainer Clips	<u>7-6</u>
Installing New Retainer Clips	<u>7-6</u>

Troubleshooting	8-1
Calling Allen-Bradley for Assistance	8-1
Tips for Troubleshooting Your Control System	8-2
Removing Power	8-2
Replacing Fuses	8-3
Program Alteration	8-3
Troubleshooting Your Fixed Controller	8-3
Identifying Fixed Controller Errors	8-4
Troubleshooting Your Input Modules	8-8
Input Circuit Operation	8-8
Corrective Action	8-9
Troubleshooting Your Output Modules	8-10
Output Circuit Operation	8-10
Corrective Action	8-11
Replacement Parts	9-1
Replacement Parts	9-1
Replacement Terminal Blocks	9-2
Setting Up the DH-485 Network	A-1
DH-485 Network Description	A-1
DH-485 Network Protocol	A-1
DH-485 Token Rotation	A-2
DH-485 Network Initialization	A-2
Devices that Use the DH-485 Network	A-3
1747-AIC Isolated Link Coupler for DH-485	A-4
Example System Configuration	A-5
Important Planning Considerations	A-6
Hardware Considerations	A-6
Number of Devices and Length of Communication Cable	A-6
Planning Cable Routes	A-6
Software Considerations	A-7
Number of Nodes	A-7
Setting Node Addresses	A-8
Setting Processor Baud Rate	A-8
Maximum Node Address Setting	A-8
DH-485 Network Installation	A-9
DH-485 Communication Cable and Isolated Link Coupler	A-9
Installing the DH-485 Communication Cable	A-10
Connecting the Communication Cable to the Isolated Link Coupler	A-11
Single Cable Connection	A-11
Single Cable Connection	A-11
Multiple Cable Connection	A-11
Grounding and Terminating the DH-485 Network	A-13
Powering the Link Coupler	A-14

Installing and Attaching the Link Couplers	A-16
The 1771-Remote I/O Network	B-1
1771-Remote I/O Network	B-1
RS-232 Communication Interface	C-1
RS-232 and SCADA Applications	C-1
RS-232 Communication Interface Overview	C-1
SLC 500 Devices that Support RS-232 Communication	C-2
1770-KF3 Module	C-2
1747-KE Module	C-2
1746-BAS Module	C-2
Wiring Connectors for RS-232 Communication	C-3
Types of RS-232 Connectors	C-3
DTE Pinout	C-4
DCE Pinout	C-4
Pin Assignments for Wiring Connectors	C-5
IBM AT to a Modem (Hardware Handshaking Enabled)	C-6
IBM AT to a 5/03 Processor, 1770-KF3, 1775-KA, 1773-KA, 5130-RM, or PLC-5 (Hardware Handshaking Disabled) À	C-6
1747-KE to a Modem (Hardware Handshaking Enabled)	C-7
1747-KE to a 5/03 Processor, IBM AT, 1770-KF3, 1775-KA, 1773-KA, 5130-RM, or PLC-5 (Hardware Handshaking Disabled) À	C-7
1746-BAS to a Modem (Hardware Handshaking Enabled)	C-8
1746-BAS to a 5/03 Processor, IBM AT, 1770-KF3, 1775-KA, 1773-KA, 5130-RM, or PLC-5 (Hardware Handshaking Disabled)À	C-8
1770-KF3 to a Modem (Hardware Handshaking Enabled)	C-8
2760-RB to a Modem (Hardware Handshaking Enabled)	C-9
2760-RB to a 5/03 Processor, IBM AT, 1770-KF3, 1775-KA, 1773-KA, 5130-RM, or PLC-5 (Hardware Handshaking Disabled) À	C-9
1771-KGM to a Modem (Hardware Handshaking Enabled)	C-10
1771-KGM to a 5/03 Processor, IBM AT, 1770-KF3, 1775-KA, 1773-KA, 5130-RM, or PLC-5 (Hardware Handshaking Disabled) À	C-10
1775-KA to a Modem (Hardware Handshaking Enabled)	C-11
1775-KA to a 5/03 Processor, IBM AT, 1770-KF3, 1773-KA, 5130-RM, or PLC-5 (Hardware Handshaking Disabled) À	C-11
PLC-5 (Channel 0) to a Modem (Hardware Handshaking Enabled)	C-12
PLC-5 (Channel 0) to a 5/03 Processor, IBM AT, 1770-KF3, 1773-KA, 5130-RM, PLC-5, 1747-KE, or 1746-BAS (Hardware Handshaking Disabled) À	C-12
5130-RM to a Modem (Hardware Handshaking Enabled)	C-13

5130-RM to a 5/03 Processor, IBM AT, 1770-KF3, 1773-KA, 5130-RM, PLC-5, 1747-KE, or 1746-BAS (Hardware Handshaking Disabled) A	C-13
Calculating Heat Dissipation for the SLC 500 Control System	D-1
Definition of Key Terms	D-1
Module Heat Dissipation: Calculated Watts vs. Maximum Watts	D-1
Use this Table to Calculate the Power Supply Loading	D-2
Example Heat Dissipation Calculation	D-4
Example Worksheet for Calculating Heat Dissipation	D-4
Worksheet for Calculating Heat Dissipation	D-5
Wiring and Circuit Diagrams and Voltage Ranges for Your Fixed Controller	E-1
Wiring Symbols	E-1
Wiring and Circuit Diagrams and Voltage Range Locations	E-2
Catalog Number 1747-L20A (12) 120 VAC Inputs & (8) Relay Outputs	E-4
Input Circuit Diagram	E-5
On/Off State Voltage Ranges	E-5
Output Circuit Diagram	E-5
Operating Voltage Range	E-5
Catalog Number 1747-L20B (12) 120 VAC Inputs & (8) Triac Outputs	E-6
Input Circuit Diagram	E-7
On/Off State Voltage Ranges	E-7
Output Circuit Diagram	E-7
Operating Voltage Range	E-7
Catalog Number 1747-L20C (12) 24 VDC Sinking Inputs, High-Speed Counter Input & (8) Relay Outputs	E-8
Input Circuit Diagram	E-9
On/Off State Voltage Ranges - Input 0 (HSC)	E-9
On/Off State Voltage Ranges - All Other Inputs	E-9
Output Circuit Diagram	E-10
Operating Voltage Range	E-10
Catalog Number 1747-L20D (12) 24 VDC Sinking Inputs, High-Speed Counter Input & (8) Triac Outputs	E-11
Input Circuit Diagram	E-12
On/Off State Voltage Ranges - Input 0 (HSC)	E-12
On/Off State Voltage Ranges - All Other Inputs	E-12
Output Circuit Diagram	E-13
Operating Voltage Range	E-13

Catalog Number 1747-L20E (12) 24 VDC Sinking Inputs, High-Speed Counter Input & (8) Transistor Sourcing Outputs	E-14
Input Circuit Diagram	E-15
On/Off State Voltage Ranges – Input 0 (HSC)	E-15
On/Off State Voltage Ranges – All Other Inputs	E-15
Output Circuit Diagram	E-16
Operating Voltage Range	E-16
Catalog Number 1747-L20F (12) 24 VDC Sinking Inputs, High-Speed Counter Input & (8) Relay Outputs	E-17
Input Circuit Diagram	E-18
On/Off State Voltage Ranges – Input 0 (HSC)	E-18
On/Off State Voltage Ranges – All Other Inputs	E-18
Output Circuit Diagram	E-19
Operating Voltage Range	E-19
Catalog Number 1747-L20G (12) 24 VDC Sinking Inputs, High-Speed Counter Input & (8) Transistor Sourcing Outputs	E-20
Input Circuit Diagram	E-21
On/Off State Voltage Ranges – Input 0 (HSC)	E-21
On/Off State Voltage Ranges – All Other Inputs	E-21
Output Circuit Diagram	E-22
Operating Voltage Range	E-22
Catalog Number 1747-L20L (12) 24 VDC Sourcing Inputs, High-Speed Counter Input & (8) Transistor Sinking Outputs	E-23
Input Circuit Diagram	E-24
On/Off State Voltage Ranges – Input 0 (HSC)	E-24
On/Off State Voltage Ranges – All Other Inputs	E-24
Output Circuit Diagram	E-25
Operating Voltage Range	E-25
Catalog Number 1747-L20N (12) 24 VDC Sourcing Inputs, High-Speed Counter Input & (8) Transistor Sinking Outputs	E-26
Input Circuit Diagram	E-27
On/Off State Voltage Ranges – Input 0 (HSC)	E-27
On/Off State Voltage Ranges – All Other Inputs	E-27
Output Circuit Diagram	E-28
Operating Voltage Range	E-28
Catalog Number 1747-L20P (12) 240 VAC Inputs & (8) Triac Outputs	E-29
Input Circuit Diagram	E-30
On/Off State Voltage Ranges	E-30
Output Circuit Diagram	E-30
Operating Voltage Range	E-30
Catalog Number 1747-L20R (12) 240 VAC Inputs & (8) Relay Outputs	E-31
Input Circuit Diagram	E-32
On/Off State Voltage Ranges	E-32
Output Circuit Diagram	E-32
Operating Voltage Range	E-32

Catalog Number 1747-L30A (18) 120 VAC Inputs & (12) Relay Outputs	E-33
Input Circuit Diagram	E-34
On/Off State Voltage Ranges	E-34
Output Circuit Diagram	E-34
Operating Voltage Range	E-34
Catalog Number 1747-L30B (18) 120 Vac Inputs & (12) Triac Outputs	E-35
Input Circuit Diagram	E-36
On/Off State Voltage Ranges	E-36
Output Circuit Diagram	E-36
Operating Voltage Range	E-36
Catalog Number 1747-L30C (18) 24 VDC Sinking Inputs, High-Speed Counter Input & (12) Relay Outputs	E-37
Input Circuit Diagram	E-38
On/Off State Voltage Ranges - Input 0 (HSC)	E-38
On/Off State Voltage Ranges - All Other Inputs	E-38
Output Circuit Diagram	E-39
Operating Voltage Range	E-39
Catalog Number 1747-L30D (18) 24 VDC Sinking Inputs, High-Speed Counter Input & (12) Triac Outputs	E-40
Input Circuit Diagram	E-41
On/Off State Voltage Ranges - Input 0 (HSC)	E-41
On/Off State Voltage Ranges - All Other Inputs	E-41
Output Circuit Diagram	E-42
Operating Voltage Range	E-42
Catalog Number 1747-L30L (18) 24 VDC Sourcing Inputs, High-Speed Counter Input & (12) Transistor Sinking Outputs	E-43
Input Circuit Diagram	E-44
On/Off State Voltage Ranges - Input 0 (HSC)	E-44
On/Off State Voltage Ranges - All Other Inputs	E-44
Output Circuit Diagram	E-45
Operating Voltage Range	E-45
Catalog Number 1747-L30P (18) 240 VAC Inputs & (12) Triac Outputs	E-46
Input Circuit Diagram	E-47
On/Off State Voltage Ranges	E-47
Output Circuit Diagram	E-47
Operating Voltage Range	E-47
Catalog Number 1747-L40A (24) 120 VAC Inputs & (16) Relay Outputs	E-48
Input Circuit Diagram	E-49
On/Off State Voltage Ranges	E-49
Output Circuit Diagram	E-49
Operating Voltage Range	E-49

Catalog Number 1747-L40B (24) 120 VAC Inputs & (16) Triac Outputs	E-50
Input Circuit Diagram	E-51
On/Off State Voltage Ranges	E-51
Output Circuit Diagram	E-51
Operating Voltage Range	E-51
Catalog Number 1747-L40C (24) 24 VDC Sinking Inputs, High-Speed Counter Input & (16) Relay Outputs	E-52
Input Circuit Diagram	E-53
On/Off State Voltage Ranges - Input 0 (HSC)	E-53
On/Off State Voltage Ranges - All Other Inputs	E-53
Output Circuit Diagram	E-54
Operating Voltage Range	E-54
Catalog Number 1747-L40E (24) 24 VDC Sinking Inputs, High-Speed Counter Input & (16) Transistor Sourcing Outputs	E-55
Input Circuit Diagram	E-56
On/Off State Voltage Ranges - Input 0 (HSC)	E-56
On/Off State Voltage Ranges - All Other Inputs	E-56
Output Circuit Diagram	E-57
Operating Voltage Range	E-57
Catalog Number 1747-L40F (24) 24 VDC Sinking Inputs, High-Speed Counter Input & (16) Relay Outputs	E-58
Wiring Diagram	E-58
Input Circuit Diagram	E-59
On/Off State Voltage Ranges - Input 0 (HSC)	E-59
On/Off State Voltage Ranges - All Other Inputs	E-59
Output Circuit Diagram	E-60
Operating Voltage Range	E-60
Catalog Number 1747-L40L (24) 24 VDC Sourcing Inputs, High-Speed Counter Input & (16) Transistor Sinking Outputs	E-61
Input Circuit Diagram	E-62
On/Off State Voltage Ranges - Input 0 (HSC)	E-62
On/Off State Voltage Ranges - All Other Inputs	E-62
Output Circuit Diagram	E-63
Operating Voltage Range	E-63
Catalog Number 1747-L40P (24) 240 VAC Inputs & (16) Triac Outputs	E-64
Input Circuit Diagram	E-65
On/Off State Voltage Ranges	E-65
Output Circuit Diagram	E-65
Operating Voltage Range	E-65
Glossary	G-1

Preface

Read this preface first. It provides an overview of the entire manual and will acquaint you with the information that is provided throughout these pages.

In this preface, you will learn about:

- who should use this manual
- how to use this manual
- related publications
- conventions used in this manual
- Allen–Bradley support

Who Should Use this Manual

The tasks and procedures in this manual require you to have some knowledge of programmable controller installation and electrical wiring. We also assume that you have a “working” knowledge of SLC™ products. If you do not have this knowledge base, obtain the proper training before attempting any of the tasks and/or procedures detailed in this manual.

How to Use this Manual

As much as possible, we organized this manual to explain, in a task-by-task manner, how to install and operate (preliminary start-up operations) the SLC 500 fixed programmable controller. This manual also provides some system design information.

Before using this manual, read over the table below and familiarize yourself with the general content of the chapters and appendixes. If you already have a topic in mind that you want to find specific information about, turn to the index at the back of the manual.

If You Want	See
An overview of the manual	The Preface
Information on how to select certain components for your SLC 500 control system	Chapter 1 — Selecting Your Hardware Components
A guide on how to prepare for the installation of your control system	Chapter 2 — System Installation Recommendations
Mounting dimensions of your fixed controller, DTAM™, and/or 1747-AIC	Chapter 3 — Mounting Your SLC 500 Control System
Procedures on how to install your hardware components	Chapter 4 — Installing Your Hardware Components
Information on how to wire the components of your SLC 500 control system	Chapter 5 — Wiring Your Control System
A guide on how to start up your control system	Chapter 6 — Starting Up Your Control System
Information on how to maintain your control system	Chapter 7 — Maintaining Your Control System
To identify error messages generated by your control system	Chapter 8 — Troubleshooting
To replace parts of your SLC 500 control system or purchase other SLC components	Chapter 9 — Replacement Parts
Information on setting up the DH-485 network	Appendix A — Setting Up the DH-485 Network
Information on the 1771-Remote I/O network	Appendix B — The 1771-Remote I/O Network
Information on configuring the RS-232 network	Appendix C — RS-232 Communication Interface
Information on how to calculate the heat dissipation of your controller	Appendix D — Calculating Heat Dissipation for the SLC 500 Control System
Wiring and circuit diagrams and voltage ranges	Appendix E — Wiring and Circuit Diagrams and Voltage Ranges for Your Fixed Controller
Definitions of terms used in this manual	The Glossary

Related Publications

The table below provides a listing of publications that contain important information about Allen–Bradley Small Logic Controllers and their installation and application. You may want to reference them while you are installing the SLC 500 controller. (To obtain a copy of one of these publications, contact your local Allen–Bradley office or distributor.)

For	Read this Document	Document Number
An overview of the SLC 500 family of products	SLC 500 System Overview	1747–2.30
A description on how to install and use your <i>Modular</i> SLC 500 programmable controller	Installation & Operation Manual for Modular Hardware Style Programmable Controllers	1747–6.2
A procedural manual for technical personnel who use APS to develop control applications	Advanced Programming Software (APS) User Manual	9399–APSUM
A reference manual that contains status file data, instruction set, and troubleshooting information about APS	SLC 500™ and MicroLogix™ 1000 Instruction Set Reference Manual	1747–6.15
An introduction to APS for first–time users, containing basic concepts but focusing on simple tasks and exercises, and allowing the reader to begin programming in the shortest time possible	APS Quick Start for New Users	9399–APSQS
A procedural and reference manual for technical personnel who use the APS import/export utility to convert APS files to ASCII and conversely ASCII to APS files	APS Import/Export User Manual	9399–APSie
A procedural and reference manual for technical personnel who use an HHT to develop control applications	Allen–Bradley Hand–Held Terminal User Manual	1747–NP002
An introduction to HHT for first–time users, containing basic concepts but focusing on simple tasks and exercises, and allowing the reader to begin programming in the shortest time possible	Getting Started Guide for HHT	1747–NM009
In–depth information on grounding and wiring Allen–Bradley programmable controllers	Allen–Bradley Programmable Controller Grounding and Wiring Guidelines	1770–4.1
A description on how to install a PLC–5® system	PLC–5 Family Programmable Controllers Hardware Installation Manual	1785–6.6.1
A description of important differences between solid–state programmable controller products and hard–wired electromechanical devices	Application Considerations for Solid–State Controls	SGL–1.1
An article on wire sizes and types for grounding electrical equipment	National Electrical Code	Published by the National Fire Protection Association of Boston, MA.
A complete listing of current Automation Group documentation, including ordering instructions. Also indicates whether the documents are available on CD–ROM or in multi–languages.	Allen–Bradley Publication Index	SD499
A glossary of industrial automation terms and abbreviations	Allen–Bradley Industrial Automation Glossary	AG–7.1

Conventions Used in this Manual

The following conventions are used throughout this manual:

- Bulleted lists such as this one provide information, not procedural steps.
- Numbered lists provide sequential steps or hierarchical information.
- *Italic* type is used for emphasis.
- Dimensions are in millimeters. (Dimensions in parentheses are in inches.)
- Text in **this font** indicates words or phrases you should type.

Allen–Bradley Support

Allen–Bradley offers support services worldwide, with over 75 Sales/Support offices, 512 authorized Distributors and 260 authorized Systems Integrators located throughout the United States alone, plus Allen–Bradley representatives in every major country in the world.

Local Product Support

Contact your local Allen–Bradley representative for:

- sales and order support
- product technical training
- warranty support
- support service agreements

Technical Product Assistance

If you need to contact Allen–Bradley for technical assistance, please review the information in the *Troubleshooting* chapter first. Then call your local Allen–Bradley representative.

Your Questions or Comments on this Manual

If you find a problem with this manual, please notify us of it on the enclosed Publication Problem Report.

If you have any suggestions for how this manual could be made more useful to you, please contact us at the address below:

Allen–Bradley Company, Inc.
Automation Group
Technical Communication, Dept. 602V, T122
P.O. Box 2086
Milwaukee, WI 53201–2086

Selecting Your Hardware Components

This chapter provides general information on what your SLC 500 controller can do for you and an overview of the fixed control system. It also explains how to select:

- 2-slot chassis
- discrete I/O modules
- specialty I/O modules
- enclosures
- operator interfaces
- memory modules
- isolation transformers
- suppressors
- output contact protection

There is also a section on special considerations for controller installations.

This chapter does not provide you with all the information that you need to select a complete SLC 500 control system. To do this, we recommend that you use the latest version of the system overview, *SLC 500 Family of Small Programmable Controllers*, Publication Number 1747-2.30.

What Your SLC 500 Controller Can Do for You

The SLC 500 programmable controller has features that previously could only be found in large programmable controllers. It has the flexibility and power of a large controller with the size and simplicity of a small controller. The SLC 500 controller offers you more control options than any other programmable controller in its class.

These programmable controllers make up a technologically advanced control system having inherent flexibility and advantages characteristic of other programmable controllers, but with one important difference — simplicity!

Overview of Your Fixed Control System

The basic fixed controller consists of a processor with 1,024 (1K) instruction capacity, a power supply, and a fixed number of I/O contained in a single package. The figure below shows typical hardware components for a fixed controller.

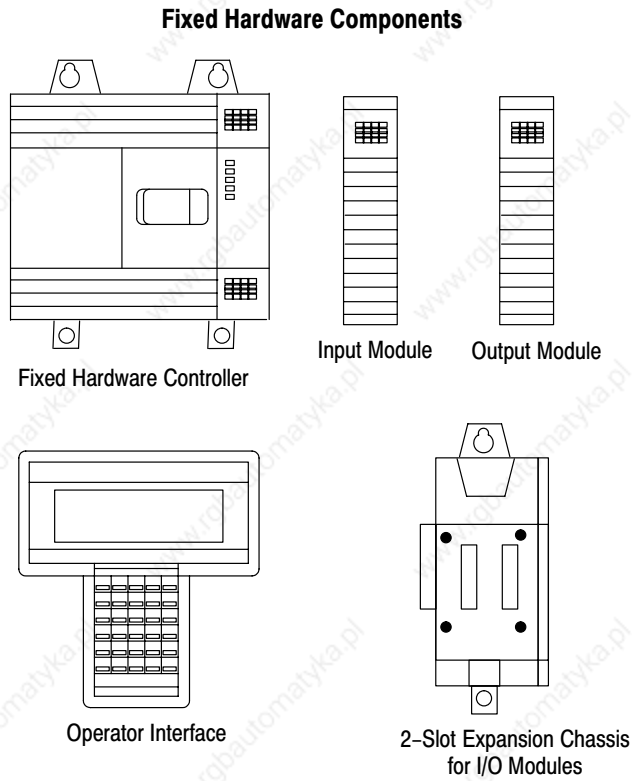

Fixed Controller with 2-slot Expansion Chassis

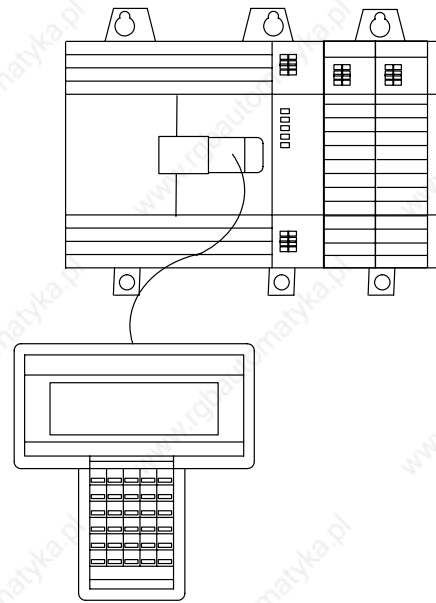

Fixed Controller Specifications

This section provides the specifications for the SLC 500 Fixed Controller.

Description	Specification
Memory Type	Capacitor-backed RAM memory. Battery back-up optional.
Memory Backup Options	EEPROM or UVPRM
Program Memory	1K Instruction Capacity
Capacitor Memory Back-up Time	Refer to curve on page 1-4.
Battery Life	5 years
Typical Scan Time ^①	8 milliseconds/1K
Bit Execution (XIC)	4 microseconds
Program Scan Hold-up Time after Loss of Power	20 milliseconds to 700 milliseconds (dependent on loading)
Power Supply Operating Voltage	AC units: 85–265 VAC 47–63 Hz DC units: 21.6–26.4 VDC (24 VDC ± 10%)
Power Supply Fuse Protection	AC units: 120/240 VAC 1.25A DC units: 24 VDC 1.6A
Power Supply Inrush Rating	30 Amperes maximum
Maximum Power Requirement	50 VA ^②
24 VDC User Power Output Current ^③	200mA
24 VDC User Power Output Voltage ^③	20.4 – 27.6 VDC (24 VDC ± 15 %)
Wire Size	#14 AWG Max.
I/O Electrical-Optical Isolation	1500 VAC at 1 minute
1747-AIC Link Coupler Electrical-Optical Isolation	1500 VDC
LED Indicators	POWER, PC RUN, CPU FAULT, FORCED I/O, and BATTERY LOW
Noise Immunity	NEMA Standard ICS 2-230
Ambient Temperature Rating	Operating: 0°C to +60°C (+32°F to +140°F) Storage: -40°C to +85°C (-40°F to +185°F)
Humidity	5 to 95% without condensation
Vibration	Displacement: .015 inch, peak-to-peak @ 5-57 Hz
	Acceleration: 2.5 Gs @ 57-2000 Hz
	Duration: 1 hr per axis (x, y, z)
Certification	UL listed/ CSA approved

^① The scan times are typical for a 1K ladder logic program consisting of simple ladder logic and communication servicing. Actual scan times depend on your program size, instructions used, and the DH-485 communication.

^② This specification does not include input and output values. (See page 1-6.)

^③ This applies only to fixed controllers that have AC line power and DC input circuits.

Memory Backup for the SLC 500 Fixed Controller

The curve below illustrates the ability of the memory back-up capacitor to maintain the contents of the RAM in a fixed controller. To back up the memory for a longer period of time, a lithium battery, Catalog Number 1747-BA, is required.

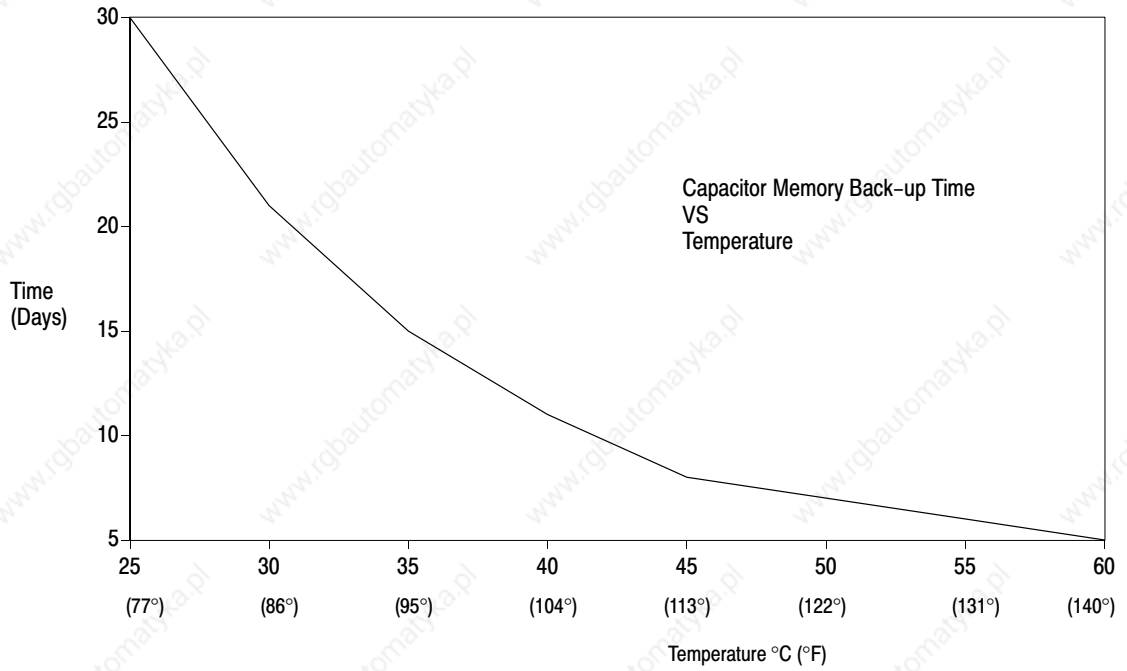

Configuration Options

The following table provides configuration options for 20, 30, or 40 I/O points.

Catalog Number	Line Power	I/O Configuration		High-Speed Counter	User Power
		Input	Output		
1747-L20A	120/240 VAC	(12) 120 Volts AC	(8) AC/DC Relay	No	NA
1747-L30A		(18) 120 Volts AC	(12) AC/DC Relay	No	NA
1747-L40A		(24) 120 Volts AC	(16) AC/DC Relay	No	NA
1747-L20B		(12) 120 Volts AC	(8) AC Triac	No	NA
1747-L30B		(18) 120 Volts AC	(12) AC Triac	No	NA
1747-L40B		(24) 120 Volts AC	(16) AC Triac	No	NA
1747-L20C		(12) 24 Volts DC Sink	(8) AC/DC Relay	Yes	24V-200mA
1747-L30C		(18) 24 Volts DC Sink	(12) AC/DC Relay	Yes	24V-200mA
1747-L40C		(24) 24 Volts DC Sink	(16) AC/DC Relay	Yes	24V-200mA
1747-L20D		(12) 24 Volts DC Sink	(8) AC Triac	Yes	24V-200mA
1747-L30D		(18) 24 Volts DC Sink	(12) AC Triac	Yes	24V-200mA
1747-L20E		(12) 24 Volts DC Sink	(8) DC Transistor Source	Yes	24V-200mA
1747-L40E		(24) 24 Volts DC Sink	(16) DC Transistor Source	Yes	24V-200mA
1747-L20L		(12) 24 Volts DC Source	(8) DC Transistor Sink	Yes	24V-200mA
1747-L30L		(18) 24 Volts DC Source	(12) DC Transistor Sink	Yes	24V-200mA
1747-L40L		(24) 24 Volts DC Source	(16) DC Transistor Sink	Yes	24V-200mA
1747-L20R		(12) 240 Volts AC	(8) AC/DC Relay	No	NA
1747-L20P		(12) 240 Volts AC	(8) AC Triac	No	NA
1747-L30P		(18) 240 Volts AC	(12) AC Triac	No	NA
1747-L40P		(24) 240 Volts AC	(16) AC Triac	No	NA
1747-L20F	24 VDC± 10%	(12) 24 Volts DC Sink	(8) AC/DC Relay	Yes	NA
1747-L40F		(24) 24 Volts DC Sink	(16) AC/DC Relay	Yes	NA
1747-L20G		(12) 24 Volts DC Sink	(8) DC Transistor Source	Yes	NA
1747-L20N		(12) 24 Volts DC Source	(8) DC Transistor Sink	Yes	NA

Input Specifications

The following table details the input specifications for SLC 500 Fixed I/O units. See the glossary for a definition of specifications.

Inputs	Specifications	
120 VAC	On-State Voltage	85–132 VAC
	Frequency	47–63 Hz
	Off-State Voltage	30 VAC (maximum)
	Inrush Current	0.8A peak
	Nominal Input Current	12mA at 120 VAC
	Turn-On Time	35 milliseconds (maximum)
	Turn-Off Time	45 milliseconds (maximum)
	Maximum Off-State Current	2mA
240 VAC	On-State Voltage	170–265 VAC
	Frequency	47–63 Hz
	Off-State Voltage	50 VAC (maximum)
	Inrush Current	1.6A peak
	Nominal Input Current	12mA at 240 VAC
	Turn-On Time	35 milliseconds (maximum)
	Turn-Off Time	45 milliseconds (maximum)
	Maximum Off-State Current	2mA
DC Sink & Source	On-State Voltage	10–30 VDC
	Off-State Voltage	4 VDC maximum for input 0 (HSC) 5 VDC for all others
	Nominal Input Current	20mA at 24 VDC (for input 0 only) 8mA at 24 VDC (all others inputs)
	Turn-On Time	8 milliseconds (maximum)
	Turn-Off Time	8 milliseconds (maximum)
	Maximum Off-State Current	1mA

Output Specifications

The following table details the output specifications for SLC 500 Fixed I/O Units.

Outputs	Specifications	
Triac	Output Voltage	85–265 VAC
	Continuous Current (per output)	0.5 Amp at +30°C 0.25 Amp at +60°C (maximum)
	Minimum Load Current	10mA
	Turn-On Time	0.1 milliseconds (maximum)
	Turn-Off Time	10 milliseconds (maximum)
	Maximum Off-State Leakage Current	2mA
	Maximum On-State Voltage Drop	1.5V @ 0.5 Amps
	Maximum Surge Current	10 Amps for 25 milliseconds ^①
Transistor Sink & Source	Output Voltage	10–50 VDC
	Continuous Current (per output)	0.5 Amp at +30°C 0.25 Amp at +60°C (maximum)
	Minimum Load Current	1mA
	Turn-On Time	0.1 millisecond (maximum)
	Turn-Off Time	1 millisecond (maximum)
	Maximum Off-State Leakage Current	1mA
	Maximum On-State Voltage Drop	1.5V @ 0.5 Amps
	Maximum Surge Current	3.0 Amps for 25 milliseconds ^①
Relay ^③	Output Voltage Range	5–265 VAC, 5–125 VDC
	Continuous Current (per output)	2.5 Amps (maximum)
	Continuous Current (per group) ^②	8 Amps (maximum)
	Maximum Load (per chassis)	1440 VA
	Turn-On Time	10 milliseconds (maximum)
	Turn-Off Time	10 milliseconds (maximum)
	Maximum Off-State Leakage Current	0mA
	Minimum Load Current at 5 VDC	10mA

^① Repeatability is once every 1 second at +30°C. Repeatability is once every 2 seconds at +60°C.

^② Refer to the wiring diagrams for output groupings on the fixed I/O chassis.

^③ Surge suppression across the output device is recommended to protect relay contacts.

Relay Contact Ratings

Maximum Volts	Amperes		Amperes Continuous	Voltamperes	
	Make	Break		Make	Break
240 VAC 120 VAC	7.5A 15A	0.75A 1.5A	2.5A	1800 VA	180 VA
125 VDC	0.22A		1.0A	28 VA	
24 VDC	1.2A		2.0A	28 VA	

To calculate make and break ratings for other load voltages, divide the voltampere rating by the load voltage; for example:

$$28 \text{ VA}/48 \text{ VDC} = 0.583 \text{ A}$$

Selecting the 2-Slot Chassis

For the 20, 30, and 40 I/O fixed controllers, an optional 2-slot expansion chassis lets you add two additional I/O modules providing even more versatility. The power supply provides backplane power for the modules in the optional expansion chassis.

Refer to chapter 3 for chassis dimensions and chapter 4 for mounting directions.

Selecting Discrete I/O Modules

There are three types of I/O modules: input, output, and combination I/O. They are available in a wide variety of densities including 4, 8, 16, and 32 point and can interface to AC, DC, and TTL voltage levels. Output modules are available with solid-state AC, solid-state DC, and relay contact type outputs.

For a complete, up-to-date listing of discrete I/O modules and their specifications, contact your Allen-Bradley sales office for the latest product data entitled *Discrete Input and Output Modules*, Publication Number 1746-2.35.

Refer to chapter 4 for installation directions.

Selecting Speciality I/O Modules

The SLC 500 family offers speciality I/O modules that enhance your control system. These modules range in function from analog interface to motion control, from communication to high-speed counting.

For a complete, up-to-date listing of speciality I/O modules and their specifications, contact your Allen-Bradley sales office for the latest System Overview entitled *SLC 500 Family of Small Programmable Controllers*, Publication Number 1747-2.30, or for a related product data.

Refer to chapter 4 for installation directions.

Selecting Enclosures

The enclosure protects the equipment from atmospheric contamination. Standards established by the National Electrical Manufacturer's Association (NEMA) define enclosure types, based on the degree of protection an enclosure will provide. Use a fan to circulate the air of sealed enclosures that use convection cooling to dissipate heat. Select a NEMA-rated enclosure that suits your application and environment. The enclosure should be equipped with a disconnect device. To calculate the heat dissipation of your controller, see appendix D.

Selecting Operator Interfaces

Use an operator interface to program and/or monitor your SLC 500 controller. You can choose from several Allen-Bradley operator interface devices.

Programming with a Hand-Held Terminal (1747-PT1)

Use the Hand-Held Terminal (HHT) to configure the SLC 500 controller, enter/modify a user program, download/upload programs, monitor control operation, and test/troubleshoot. When equipped with a battery (1747-BA), the HHT retains a user program in memory for storage and later use.

The display area accommodates 8 lines x 40 characters. You can display five rungs of a user program. The top row of keys are the menu function keys.

Important: Using the HHT, you can program the SLC 5/01™ and 5/02™ processors and the SLC 500 fixed controllers. You cannot, however, program the SLC 5/03 processor.

Refer to the *Hand-Held Terminal User Manual*, Catalog Number 1747-NP002, for information on programming your fixed controller with the HHT.

Programming with Advanced Programming Software (APS) on an IBM Compatible Computer

The Advanced Programming Software (APS) can be used with an Allen-Bradley T45, T47, or T50 terminal, an IBM®-AT or XT, a Compaq® Portable, Portable II, Deskpro™ 286, 386/SX, 386, a Tandy™ 3000HL, Toshiba™ 3100E, or GATEWAY 2000™ models 386DX/25, 386DX/33, 486DX/33, and 486DX2/50 personal computer. Your computer must have:

- 640 Kbytes of RAM (extended or expanded memory is recommended, but not required)
- 10 Mbyte fixed-disk drive (APS requires a minimum of 2.5 MBytes of free disk space.)
- DOS version 3.1 or higher

Advanced Programming Software, 1747-PA2E

APS, Catalog Number 1747-PA2E, comes on 5-1/4 and 3-1/2 inch disks. You must have DOS installed in your computer. You also must have at least 550 Kbytes of free memory to execute the APS software. Like the Hand-Held Terminal, APS lets you configure the SLC 500 controller, enter/modify a user program, restore/save programs to the SLC 500, monitor controller operation, and test/troubleshoot. You can also:

- create and print ladder diagrams, data tables, instruction cross references, and configurations
- use cut/copy/paste editor
- store multiple programs in the memory of the computer (on the hard disk)

Refer to the *Advanced Programming Software User Manual*, Catalog Number 1747-NM002, and the *Advanced Programming Software Reference Manual*, Catalog Number 1747-NR001, for information on programming your fixed controller with APS.

DH-485 Interface Converter (1747-PIC)

For communication, use an RS-232/DH-485 Interface Converter between the computer and SLC controller. The converter includes a 279.4 mm (11.0 in.) ribbon cable, already attached to the converter, for connection to the computer serial port and a Catalog Number 1746-C10 cable for connection to the controller.

Monitoring with a Data Table Access Module (1747-DTAM-E)

The Data Table Access Module (DTAM) is a plant floor device that lets you access data file information, change operating modes, monitor and clear processor faults, and transfer the user program between RAM and an EEPROM memory module with any SLC 500 family processor. *You cannot use it to create new programs.*

Important features of DTAM include:

- shorthand addressing, which provides easier access to data files
- display prompts in six, user-selectable languages: English, French, German, Italian, Spanish, and Japanese
- UL listed, CSA Certified
- NEMA type 12 and 13 enclosures
- point-to-point interface to an SLC family processor, or as a network device on a DH-485 network

Refer to the *Data Table Access Module (DTAM) User Manual*, Catalog Number 1747-ND013, for information on monitoring your fixed controller with the DTAM.

EEPROM and UVPROM Memory Modules

These optional memory modules provide a non-volatile memory back-up in a convenient modular form. The modules plug into a socket on the controller.

You can store (save) your program in the EEPROM by inserting it into the processor and using either the Hand-Held Terminal or Advanced Programming Software.

Use of the UVPROM provides you with an extra degree of program security because the user program cannot be altered while it is installed in the controller. You can program the UVPROM with commercially available UVPROM programming and erasing equipment. You can use an EEPROM module as a master, or you can use an archived processor file as the source by using the APS PROM translator utility.

Adapter sockets are required when inserting memory modules into commercially available PROM programmer. The memory module fits into the adapter socket and then into a PROM programmer.



ATTENTION: Make sure the adapter is inserted properly or damage could result.

The following table lists the types of memory modules that are available for the fixed controller. Also listed are the manufacturer part number for determining compatibility with an external PROM burner.

Description	Catalog Number	Manufacturer	Manufacturer's Part Number
1K User Words EEPROM	1747-M1	NEC	uPD28C64 - 250
		OKI	MSM28C64ARS - 20
		XICOR	X28C64BP - 25
		SEEQ	PE28C64 - 250
4K User Words EEPROM	1747-M2	XICOR	X28C256DI - 25
			X28256DI - 25
		SEEQ	DE28C256 - 25
1K User Words UVPROM	1747-M3	Fujitsu	MBM27C64 - 25
4K User Words UVPROM	1747-M4	Not compatible with the fixed controller.	
Adaptor Socket	1747-M5	NA	NA

Selecting Isolation Transformers

If there is high frequency conducted noise in or around your distribution equipment, we recommend that you use an isolation transformer in the AC line to the power supply. This type of transformer provides isolation from your power distribution system and is often used as a “step down” transformer to reduce line voltage. Any transformer used with the controller must have a sufficient power rating for its load. This power rating is generally expressed in voltamperes (VA).

To select an appropriate isolation transformer, you must calculate the power required by the fixed I/O chassis and any input circuits and output loads that are connected through this transformer. The power requirement of any fixed I/O unit is 50 VA.

The power requirement for the input circuits is determined by the number of inputs, the operating voltage, and the nominal input current. The power requirement for output loads is determined by the number of outputs, the load voltage, and load current.

For example, if you have a 1747-L30B fixed unit with 18 AC inputs (12mA at 120 VAC) and 12 triac outputs (0.5A at 120 VAC), the power consumed would be:

$$50 + (18)(120)(0.012) + (12)(120)(0.5) = 796 \text{ VA}$$

Important: In this case, 0.5 Amp is the maximum rating of the triac output (at +30° C). If your load draws less than 0.5 Amp, this figure may be reduced accordingly. The output portion of the VA calculation should reflect the current requirements of your loads.

In general, we recommend that the transformer is oversized to provide some margin for line voltage variations and other factors. Typically a transformer that is 25% larger than the calculated VA is sufficient.

Special Considerations

The recommendations given previously provide favorable operating conditions for most controller installations. Your application may involve one or more of the following adverse conditions. Additional measures can be taken to minimize the effect of these conditions.

Excessive Line Voltage Variations

The best solution for excessive line voltage variation is to correct any feeder problems in your distribution system. Where this does not solve the line variation problem, or in certain critical applications, use a constant voltage transformer. If you require a constant voltage transformer, connect it to the power supply *and* all input devices connected to the SLC 500 controller.

Connect output devices on the same power line, but their connection along the power line is normally made before the constant voltage transformer. A constant voltage transformer must have a sufficient power rating for its load.

Excessive Noise

When you operate the SLC 500 controller in a “noise polluted” industrial environment, special consideration should be given to possible electrical interference.

The following reduces the effect of electrical interference:

- SLC 500 controller design features
- proper mounting of controller within an enclosure
- proper equipment grounding
- proper routing of wiring
- proper suppression added to noise generating devices

Potential noise generators include inductive loads, such as relays, solenoids, and motor starters when operated by “hard contacts” like push buttons or selector switches. Suppression may be necessary when such loads are connected as output devices or when connected to the same supply line that powers the controller.

Lack of surge suppression on inductive loads may attribute to processor faults and sporadic operation, RAM memory can be corrupted (lost) and I/O modules may appear to be faulty or reset themselves.

For extremely noisy environments, use a memory module and program it for auto loading on processor fault or power cycle for quick recovery.

Selecting Surge Suppressors

Most output modules have built-in surge suppression to reduce the effects of high voltage transients. However, we recommend that you use an additional suppression device if an output module is being used to control an inductive device such as:

- relays
- solenoids
- motor starters
- motors

Additional suppression is especially important if your inductive device is in series with or parallel to a hard contact such as:

- pushbuttons
- selector switches

By adding a suppression device directly across the coil of an inductive device, you will reduce the effects of voltage transients caused by interrupting the current to that inductive device and prolong the life of the switch contacts. The diagram below shows an output module with a suppression device.

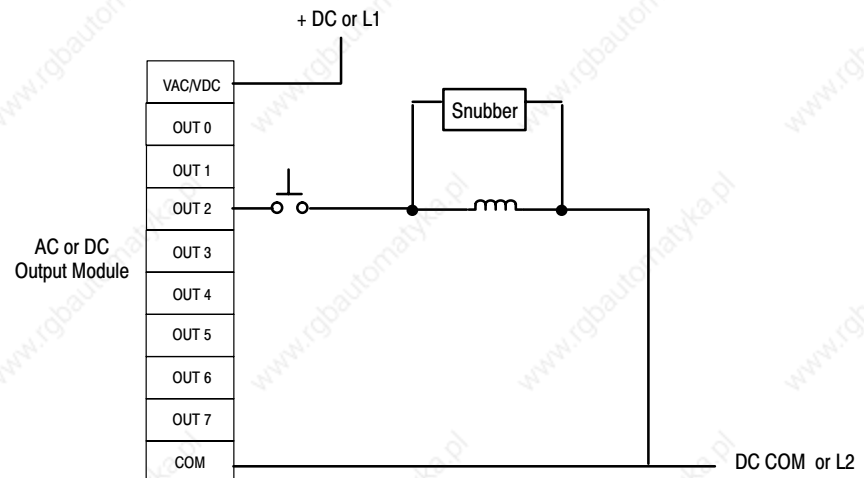

If you connect an SLC 500 controller triac output to control an inductive load, we recommend that you use varistors to suppress noise. Choose a varistor that is appropriate for the application. The surge suppression we recommend for triac outputs when switching 120 VAC inductive loads is Harris MOV, part number V220 MA2A. For a 509 motor starter, use a 599-K04 or 599-KA04 series C or later MOV with triac outputs.

Consult the varistor manufacturer's data sheet when selecting a varistor for your application.



ATTENTION: Damage could occur to SLC 500 triac outputs if you use suppressors having RC networks. Allen-Bradley AC surge suppressors *not recommended* for use with triacs include Catalog Numbers 199-FSMA1, 199-FSMA2, 1401-N10, and 700-N24.

Chapter 1 Selecting Your Hardware Components

Allen–Bradley surge suppressors recommended for use with Allen–Bradley relays, contactors, and starters are shown in the table below.

Device	Coil Voltage	Suppressor Catalog Number
Bulletin 509 Motor Starter Bulletin 509 Motor Starter	120 VAC 240 VAC	599-K04 ^① 599-KA04 ^①
Bulletin 100 Contactor Bulletin 100 Contactor	120 VAC 240 VAC	199-FSMA1 ^② 199-F5MA2 ^②
Bulletin 709 Motor Starter	120 VAC	1401-N10 ^②
Bulletin 700 Type R, RM Relays	AC coil	None Required
Bulletin 700 Type R Relay Bulletin 700 Type RM Relay	12 VDC 12 VDC	700-N22 700-N28
Bulletin 700 Type R Relay Bulletin 700 Type RM Relay	24 VDC 24 VDC	700-N10 700-N13
Bulletin 700 Type R Relay Bulletin 700 Type RM Relay	48 VDC 48 VDC	700-N16 700-N17
Bulletin 700 Type R Relay Bulletin 700 Type RM Relay	115–125 VDC 115–125 VDC	700-N11 700-N14
Bulletin 700 Type R Relay Bulletin 700 Type RM Relay	230–250 VDC 230–250 VDC	700-N12 700-N15
Bulletin 700 Type N, P, or PK Relay	150V max, AC or DC	700-N24 ^②
Miscellaneous electromagnetic devices limited to 35 sealed VA		

^① This is an MOV without a capacitor. The 599-K04 or 599-KA04 MOV must be series C or later when used with triac outputs. Do not use series A or B with triac outputs.

^② Not recommended for use with triac outputs.

Selecting Contact Protection

Inductive load devices such as motor starters and solenoids may require the use of some type of surge suppression to protect the controller output contacts. Switching inductive loads without surge suppression can *significantly* reduce lifetime of relay contacts. The figure below shows the use of surge suppression devices.

Surge Suppression for Inductive AC Load Devices

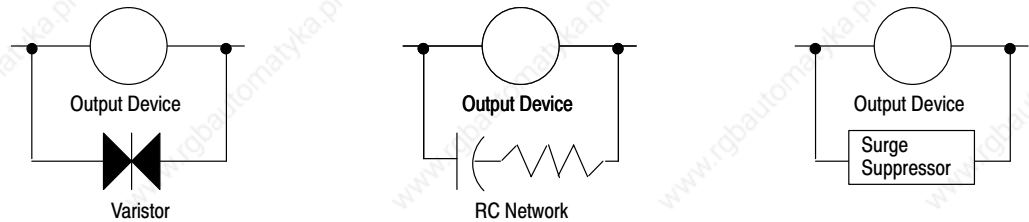

Surge Suppression for Inductive DC Load Devices

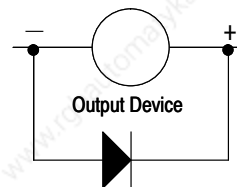

Diode (A surge suppressor can also be used.)

Contact Protection Methods for Inductive AC and DC Output Devices

These surge suppression circuits connect directly across the load device. This reduces arcing of the output contacts. Suitable surge suppression methods for inductive AC load devices include a varistor, an RC network, or an Allen–Bradley surge suppressor. These components must be appropriately rated to suppress the switching transient characteristic of the particular inductive device.

For inductive DC load devices, a diode is suitable. A 1N4004 diode is acceptable for most applications. A surge suppressor can also be used. See table on page 1–15.

We recommend that you locate the suppression device as close as possible to the load device.

Transistor Output Transient Pulses

This section applies to the following SLC 500 Fixed I/O processors and SLC 500 I/O modules that have transistor outputs.

Fixed I/O Processors	I/O Modules
1747-L20E	1746-OB8
1747-L20G	1746-OV8
1747-L20L	1746-OB16
1747-L20N	1746-OBP16
1747-L30L	1746-OV16
1747-L40E	1746-OB32
1747-L40L	1746-OV32

For the SLC 500 products listed above, the maximum duration of the transient pulse occurs when minimum load is connected to the output. However, for most applications the energy of the transient pulse is not sufficient to energize the load.



ATTENTION: A transient pulse occurs in transistor outputs when the external DC supply voltage is applied to the common output terminals (e.g., via the master control relay). The sudden application of voltage creates this transient pulse. (See the following graph.) This condition is inherent in transistor outputs and is common to solid state devices. A transient pulse can occur regardless of the processor having power or not.

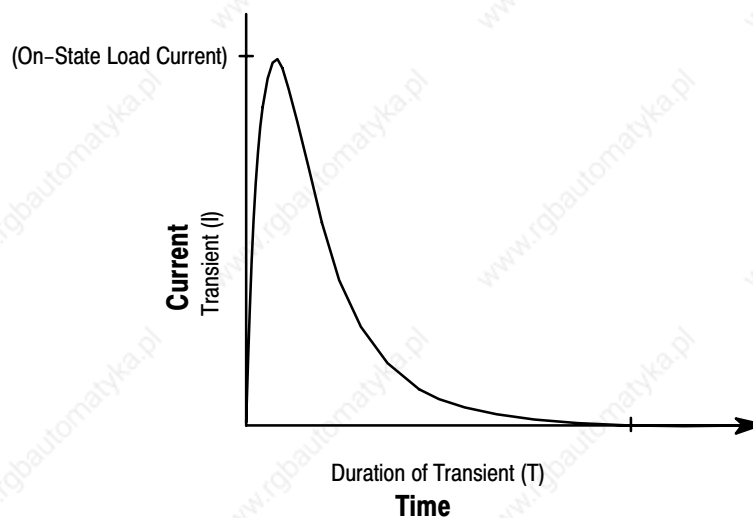

To reduce the possibility of inadvertent operation of devices connected to transistor outputs, adhere to the following guidelines:

- Either ensure that any programmable device connected to the transistor output is programmed to ignore all output signals until after the transient pulse has ended,
- or add an external resistor in parallel to the load to increase the on-state load current. The duration of the transient pulse is reduced when the on-state load current is increased.

The duration of the transient pulse is proportional to the load impedance. This is illustrated in the following graph.

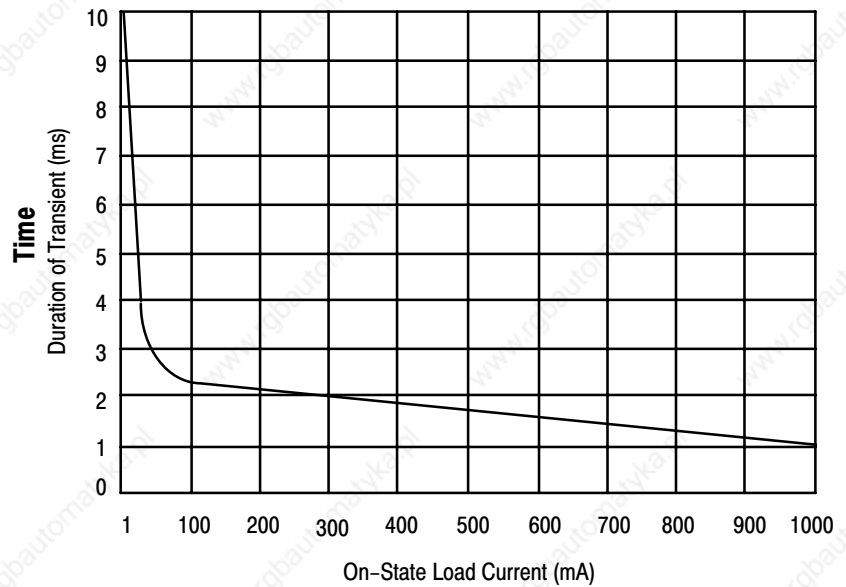

Example

Increasing the load current by 100mA decreases the transient time from approximately 7 ms to less than 2.5 ms. To calculate the size of the resistor added in parallel to increase the current, use the following information:

24V = your applied voltage

Need 100mA of load current to reduce the transient to < 2.5 ms. (taken from graph on previous page)

$$R \text{ (Ohms)} = \frac{V \text{ (Volts)}}{I \text{ (Amps)}}$$

$$\begin{aligned} \text{Resistor value (Ohms)} &= \text{Applied voltage (Volts)} / \text{Desired current (Amps)} \\ &= 24 / 0.1 \\ &= 240 \text{ (Ohms)} \end{aligned}$$

$$P \text{ (Watts)} = I^2 \text{ (Amps)} \times R \text{ (Ohms)}$$

$$\begin{aligned} \text{Actual Power (Watts)} &= (\text{Desired Current})^2 \times \text{Resistor Value} \\ &= (0.1)^2 \times 240 \\ &= 2.4 \text{ (Watts)} \end{aligned}$$

$$\begin{aligned} \text{Resistor size} &= 2 \times \text{Actual power (Watts)} \\ &= 2 \times 2.4 \\ &= 4.8 \text{ (Watts)} \end{aligned}$$

Round resistor size to 5 Watts.

You need a resistor rated for 240 Ohms at 5 Watts to increase the load current by 100mA; thus decreasing the transient time from approximately 7 ms to less than 2.5 ms.

System Installation Recommendations

To help you install the SLC 500 programmable controller as safely and securely as possible, we have set up a few specific recommendations for you to follow.

For general installation guidelines, also refer to article 70E of the National Fire Protection Association (NFPA). Article 70E describes electrical safety requirements for employee workplaces. This chapter covers the following:

- typical installation
- spacing your controllers
- preventing excessive heat
- grounding guidelines
- master control relay
- power considerations
- safety considerations
- preventative maintenance

Typical Installation

The figure below consists of some components that make up a typical installation. The following symbols are used:

- ① NEMA rated enclosure suitable for your application and environment that shields your controller from electrical noise and airborne contaminants.
- ② Disconnect, to remove power from the system
- ③ Fused isolation transformer or a constant voltage transformer, as your application requires
- ④ Master control relay/emergency stop circuit
- ⑤ Terminal blocks or wiring ducts
- ⑥ Suppression devices for limiting EMI (electromagnetic interference) generation

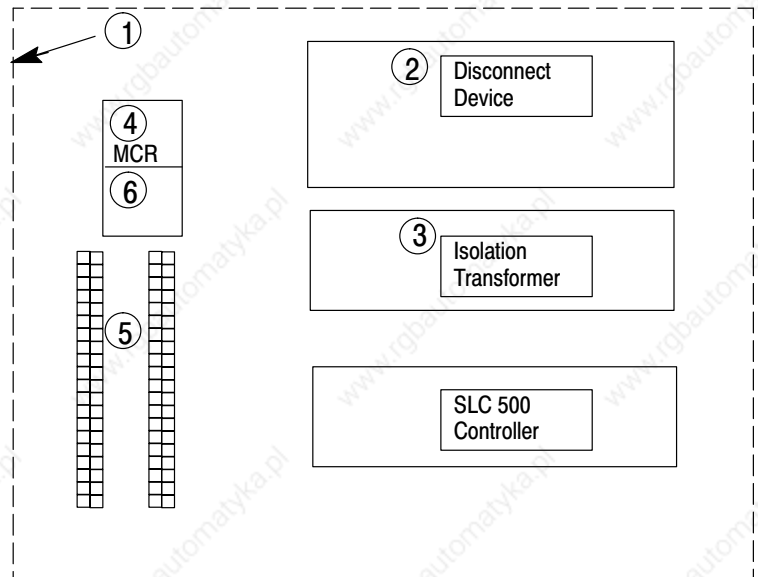

Spacing Your Components

Follow the recommended minimum spacing shown below to allow for convection cooling within the enclosure. Air in the enclosure must be kept within a range of 0° to +60° C (+32° to +140° F).

Important: Be careful of metal chips when drilling mounting holes for the controllers. Do not drill holes above a mounted SLC 500 controller. Metal chips or clippings may short circuit electronic components of the controller and cause intermittent or permanent malfunction.

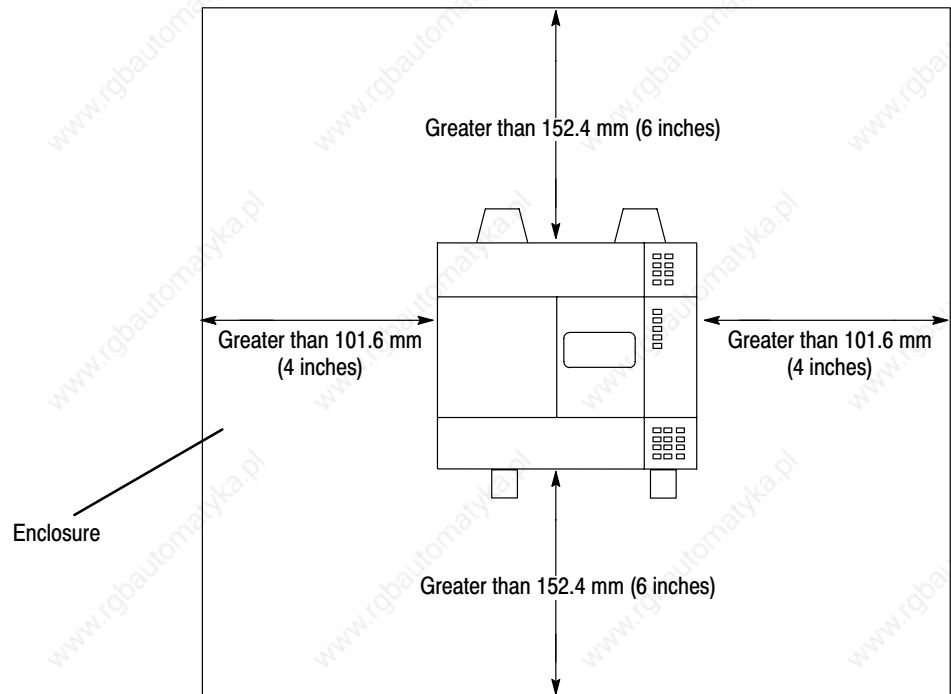

Preventing Excessive Heat

For most applications, normal convection cooling will keep the controller components within the specified operating range. Proper spacing of components within the enclosure is usually sufficient for heat dissipation.

In some applications, a substantial amount of heat is produced by other equipment inside or outside the enclosure. In this case, place blower fans inside the enclosure to assist in air circulation and to reduce “hot spots” near the controller.

Additional cooling provisions might be necessary when high ambient temperatures are encountered.

Important: Do not bring in unfiltered outside air. It may introduce harmful contaminants of dirt that could cause improper operation or damage to components. In extreme cases, you may need to use air conditioning to protect against heat build-up within the enclosure.

Grounding Guidelines

In solid-state control systems, grounding helps limit the effects of noise due to electromagnetic interference (EMI). The grounding path for the controller and its enclosure is provided by the equipment grounding conductor.

Normal Electrical Noise Conditions

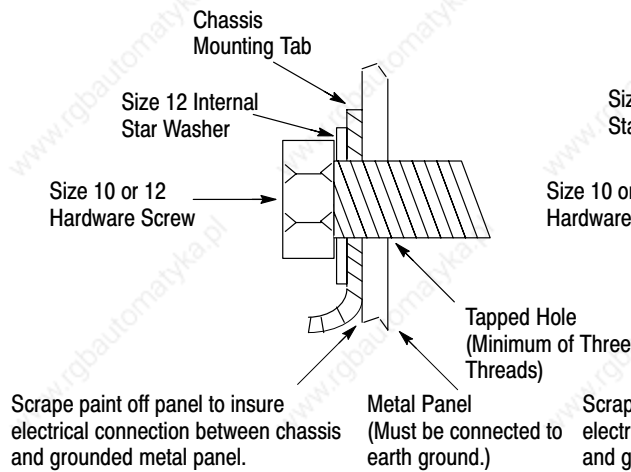

Severe Electrical Noise Conditions

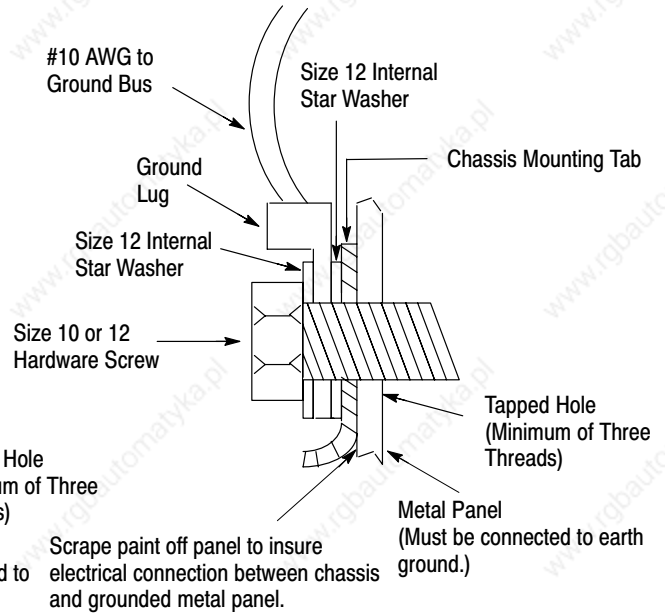

ATTENTION: The SLC 500 controller, other control devices, and the enclosure must be properly grounded. All applicable codes and ordinances must be observed when wiring the controller system.

Ground connections should run from the chassis and power supply on each controller and expansion unit to the ground bus. Exact connections will differ between applications. An authoritative source on grounding requirements for most installations is the National Electrical Code. Also, refer to *Allen-Bradley Programmable Controller Grounding and Wiring Guidelines*, Publication Number 1770-4.1.

In addition to the grounding required for the controller and its enclosure, you must also provide proper grounding for all controlled devices in your application. Care must be taken to provide each device with an acceptable grounding path.

The figure below shows you how to run ground connections from the chassis to the ground bus.

SLC 500 Controller Only

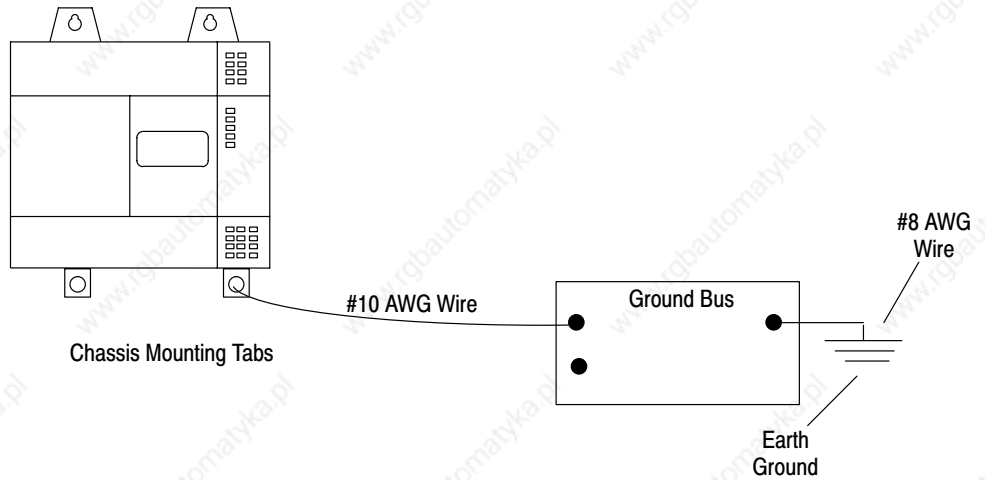

SLC 500 Controller with 2-slot Expansion Chassis

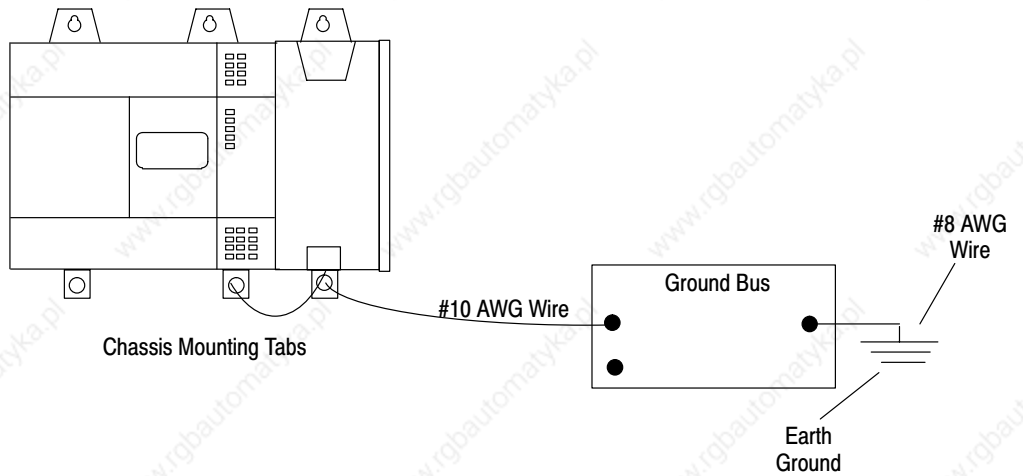

Master Control Relay

A hard-wired master control relay (MCR) provides a convenient means for emergency controller shutdown. Since the master control relay allows the placement of several emergency-stop switches in different locations, its installation is important from a safety standpoint. Overtravel limit switches or mushroom head push buttons are wired in series so that when any of them opens, the master control relay is de-energized. This removes power to input and output device circuits. Refer to the figure on page 2-6.



ATTENTION: Never alter these circuits to defeat their function, since serious injury and/or machine damage could result.

Important: If you are using a DC output power supply, interrupt the output side rather than the AC line to avoid the additional delay of power supply turn-on and turn-off. The power supply should receive its power directly from the fused secondary of the transformer. Connect the power to the DC input and output circuits through a set of master control relay contacts.

Place the main power disconnect switch where operators and maintenance personnel have quick and easy access to it. If you mount a disconnect switch inside the controller enclosure, place the switch operating handle on the outside of the enclosure, so that you can disconnect power without opening the enclosure.

Whenever any of the emergency-stop switches are opened, power to input and output devices is stopped.

When you use the master control relay to remove power from the external I/O circuits, power continues to be provided to the controller's power supply so that diagnostic indicators on the processor can still be observed.

The master control relay is not a substitute for a disconnect to the controller. It is intended for any situation where the operator must quickly de-energize I/O devices only. When inspecting or installing terminal connections, replacing output fuses, or working on equipment within the enclosure, use the disconnect to shut off power to the rest of the system.

Important: The operator must not control the master control relay with the SLC 500 controller. Provide the operator with the safety of a direct connection between an emergency-stop switch and the master control relay.

Emergency-Stop Switches

Adhere to the following points concerning emergency-stop switches:

- Do not program emergency-stop switches in the controller program. Any emergency-stop switch should turn off all machine power by turning off the master control relay.
- Observe all applicable local codes concerning the placement and labeling of emergency-stop switches.
- Install emergency-stop switches and the master control relay in your system. Make certain that relay contacts have a sufficient rating for your application. Emergency-stop switches must be easy to reach.

The figure below shows the Master Control Relay Wired in Grounded System.

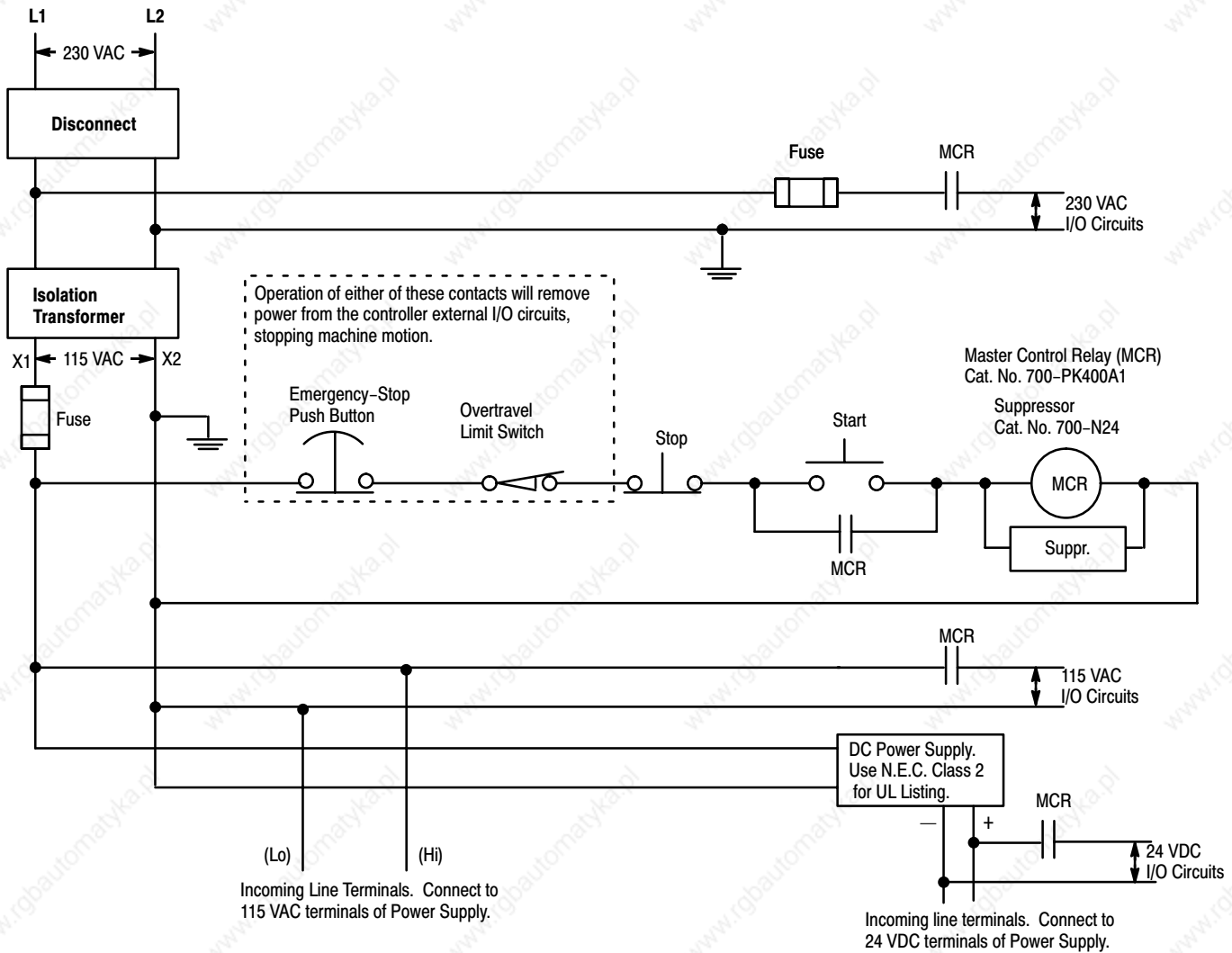

Power Considerations

The following explains power considerations for the SLC 500 fixed controller.

Common Power Source

We strongly recommend that the chassis power supply has the same power source as the input and output devices. This helps:

- reduce the chance of electrical interference due to multiple sources and grounds
- maintain system integrity if power is interrupted

Loss of Power Source

The chassis power supply is designed to withstand brief power losses without affecting the operation of the system. The time the system is operational during power loss is called “program scan hold-up time after loss of power.” The duration of the power supply hold-up time depends on the number, type and state of the I/O, but is typically between 20 ms and 700 ms. When the duration of power loss reaches a limit, the power supply signals the processor that it can no longer provide adequate DC power to the system. This is referred to as a power supply shutdown. The POWER LED is turned off.

Input States on Power Down

The power supply hold-up time as described above is generally longer than the turn-on and turn-off times of the input circuits. Because of this, the input state change from “On” to “Off” that occurs when power is removed may be recorded by the processor before the power supply shuts down the system. Understanding this concept is important. The user program should be written to take this effect into account. For example, hard wire power to one spare input. In the user program, check to be sure that one input is on; otherwise, jump to the end of the program and avoid scanning the logic. Use of a common power source as recommended in the previous section is assumed.

Other Types of Line Conditions

Occasionally the power source to the system can be temporarily interrupted. It is also possible that the voltage level drops substantially below the normal line voltage range for a period of time. Both of these conditions are considered to be a loss of power for the system.

Safety Considerations

Safety considerations are an important element of proper system installation. Actively thinking about the safety of yourself and others, as well as the condition of your equipment, is of primary importance. Several safety areas are discussed below.

High Voltages – SLC 500 Fixed Hardware Style Controller (Series C) (Applies to 1747-L20A, -L30A, -L40A, -L20C, -L30C, and -L40C controllers)

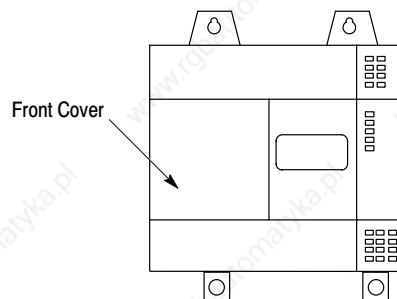

ATTENTION: The printed circuit board, located under the front cover of Series C Fixed Hardware Style Controllers, has high voltages (120 VAC and 240 VAC) available at certain points when the controller is powered up. If the front cover is removed, exercise extreme care and consider all points on the circuit board to be electrically hazardous. Therefore, whenever possible, turn off power to the controller before removing the front cover. *Do not* remove the protective insulation covering the circuit board. Cutouts in the insulation are provided to allow access to the high-speed counter jumper, memory module, and battery connector. If the insulation is missing, do not touch any portion of the circuit board. Failure to heed this warning may result in personal injury or death.

Disconnecting Main Power

The main power disconnect switch should be located where operators and maintenance personnel have quick and easy access to it. Ideally, the disconnect switch is mounted on the outside of the enclosure, so that it can be accessed without opening the enclosure. In addition to disconnecting electrical power, all other sources of power (pneumatic and hydraulic) should be de-energized before working on a machine or process controlled by an SLC controller.

Wiring Safety Circuits

Circuits installed on the machine for safety reasons, like overtravel limit switches, stop push buttons, and interlocks, should always be hard-wired directly to the master control relay. These devices must be wired in series so that when any one device opens, the master control relay is de-energized thereby removing power to the machine. Never alter these circuits to defeat their function. Serious injury or machine damage could result.

Distributing Power

There are some points about power distribution that you should be aware of. First, the master control relay must be able to inhibit all machine motion by removing power to the machine I/O devices when the relay is de-energized.

Second, if you are using a DC power supply, interrupt the load side rather than the AC line power. This avoids the additional delay of power supply turn-on and turn-off. The DC power supply should be powered directly from the fused secondary of the transformer. Power to the DC input and output circuits is connected through a set of master control relay contacts.

Testing the Master Control Relay Circuit

Any part can fail, including the switches in a master control relay circuit. The failure of one of these switches would most likely cause an open circuit, which would be a safe power-off failure. However, if one of these switches shorts out, it no longer provides any safety protection. These switches should be tested periodically to assure they will stop machine motion when needed.

Preventive Maintenance

The printed circuit boards of the controller must be protected from dirt, oil, moisture, and other airborne contaminants. To protect these boards, the controller must be installed in an enclosure suitable for the environment. The interior of the enclosure should be kept clean and the enclosure door should be kept closed whenever possible.

Regularly inspect your terminal connections for tightness. Loose connections may cause improper functioning of the controller or damage the components of the system.



ATTENTION: To ensure personal safety and to guard against damaging equipment, inspect connections with incoming power off.

The National Fire Protection Association (NFPA) provides recommendations for electrical equipment maintenance. Refer to article 70B of the NFPA for general requirements regarding safety related work practices.

Mounting Your SLC 500 Control System

This chapter provides you with mounting dimensions for the following SLC 500 components:

- 20 I/O fixed controller
- 30 & 40 I/O fixed controller
- 2-slot expansion chassis
- link coupler (AIC)
- Data Table Access Module (DTAM)

Mounting Fixed Hardware Style Units

You can mount the fixed hardware style units directly to the back panel of your enclosure using the mounting tabs and #10 and #12 screws. The torque requirement is 3.4 N-m (30 in-lbs) maximum. Dimensions are in millimeters. (Dimensions in parentheses are in inches.)

Chapter 3

Mounting Your SLC 500 Control System

20 I/O Fixed Controller^①

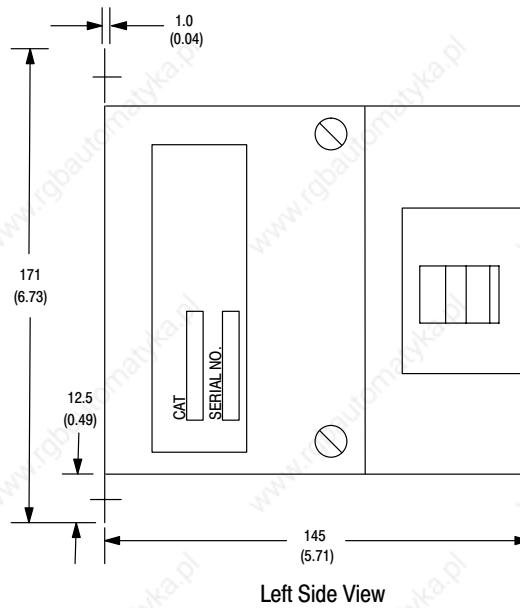
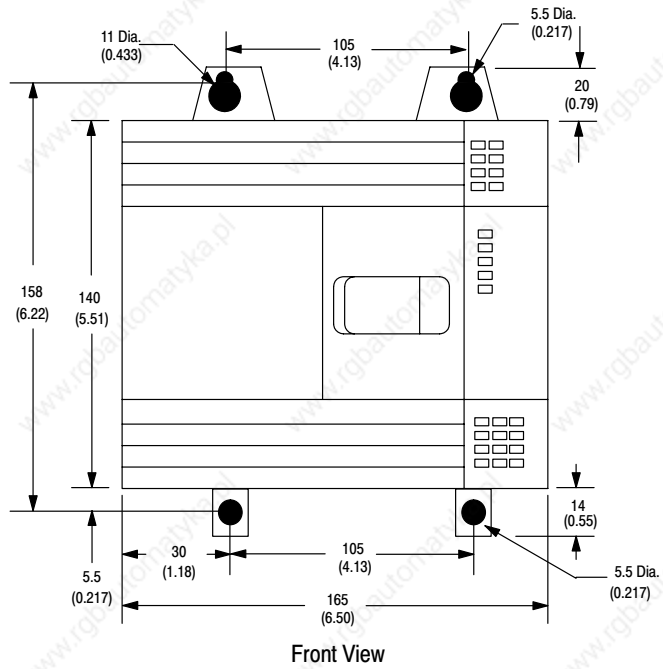

^① Dimensions are in millimeters. (Dimensions in parentheses are in inches.)

30 and 40 I/O Fixed Controller^①

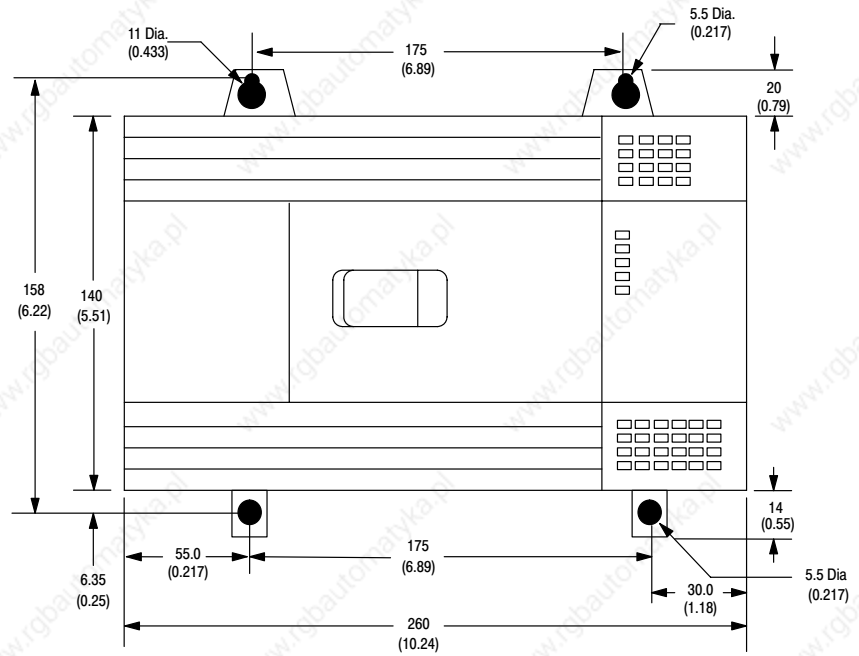

Front View

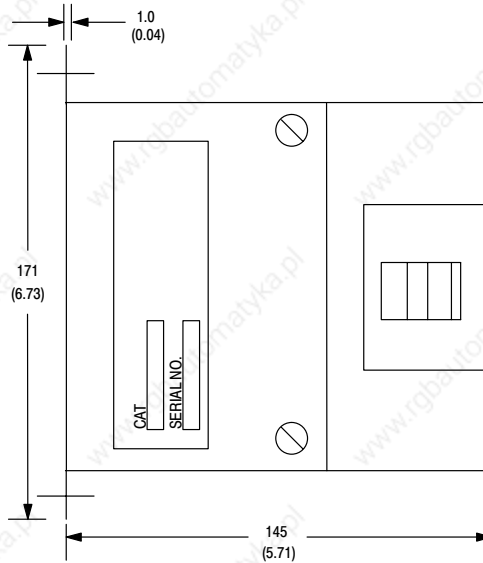

Left Side View

^① Dimensions are in millimeters. (Dimensions in parentheses are in inches.)

Chapter 3

Mounting Your SLC 500 Control System

2-Slot Expansion Chassis^①

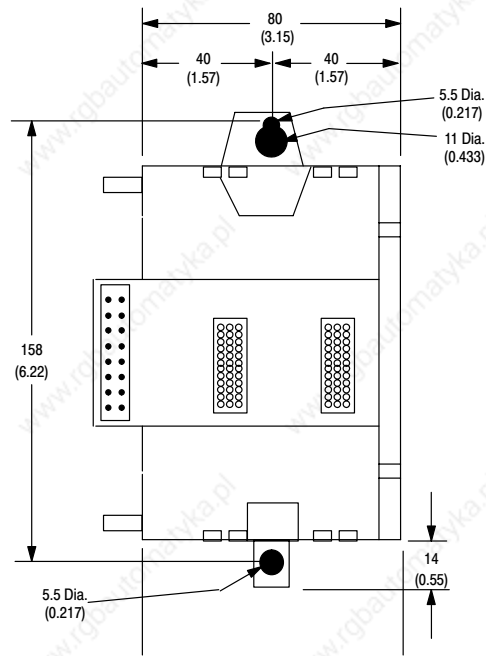

Front View

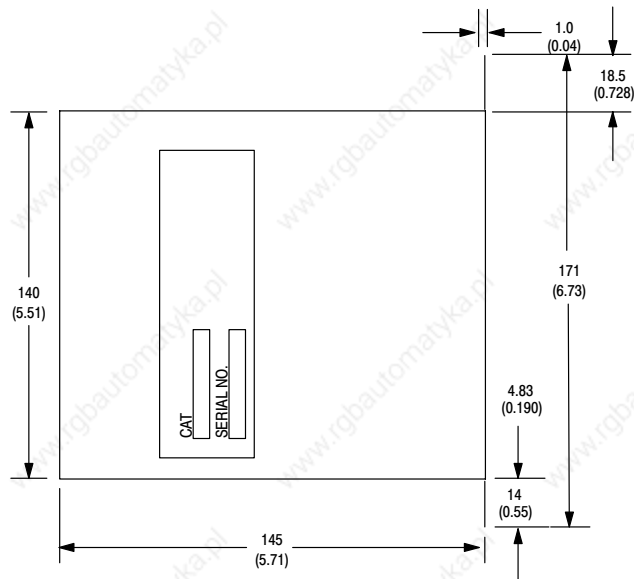

Right Side View

^① Dimensions are in millimeters. (Dimensions in parentheses are in inches.)

Link Coupler (AIC)^①

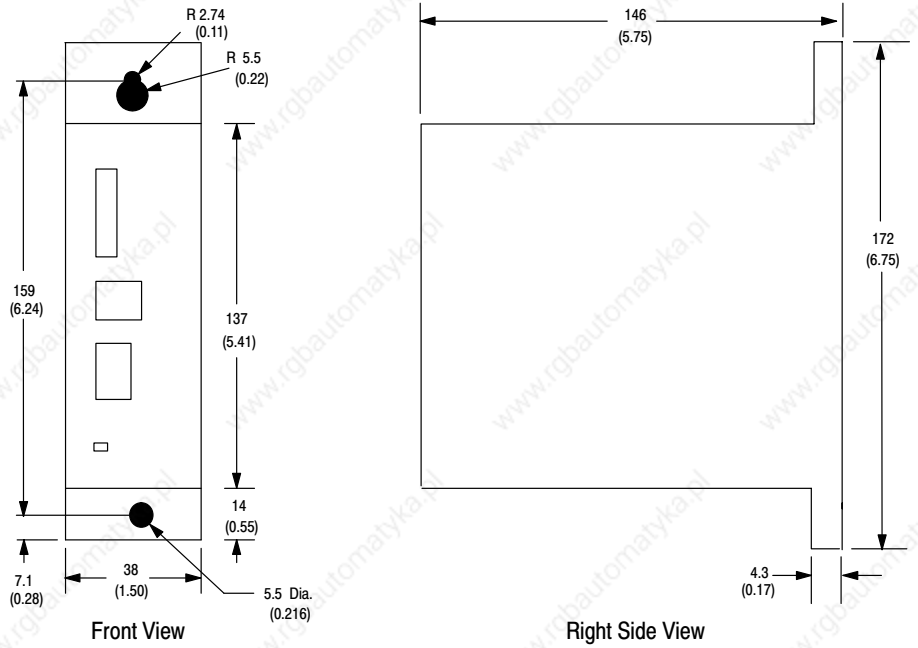

Data Table Access Module (DTAM)^①

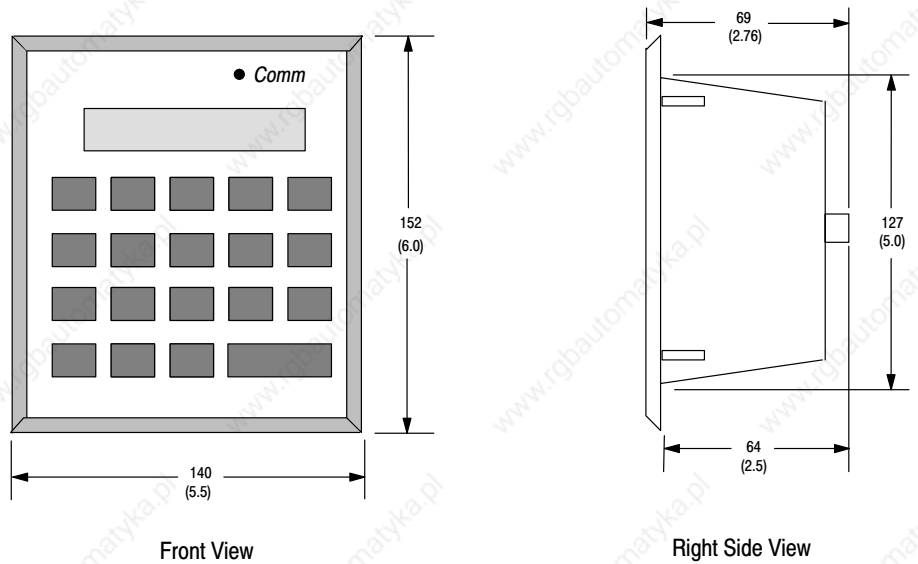

^① Dimensions are in millimeters. (Dimensions in parentheses are in inches.)

Installing Your Hardware Components

This chapter shows you how to install and remove the following hardware components:

- 2-slot expansion chassis
- I/O and speciality modules
- memory module
- high-speed counter

Mounting the 2-Slot Expansion Chassis

The expansion chassis mounts on the right side of the fixed controller. The chassis has mounting tabs that are inserted into slots in the fixed controller and slid forward. No tools are required.

1. Insert the mounting tabs of the expansion chassis into the mounting slots of the controller.

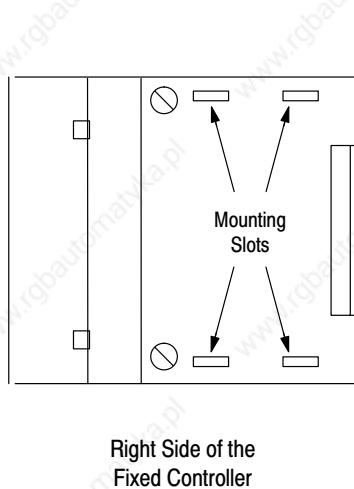

2. Slide the expansion chassis forward until the back of the expansion chassis is flush with the fixed controller and the connector on the expansion circuit board is mated with the connector in the controller.

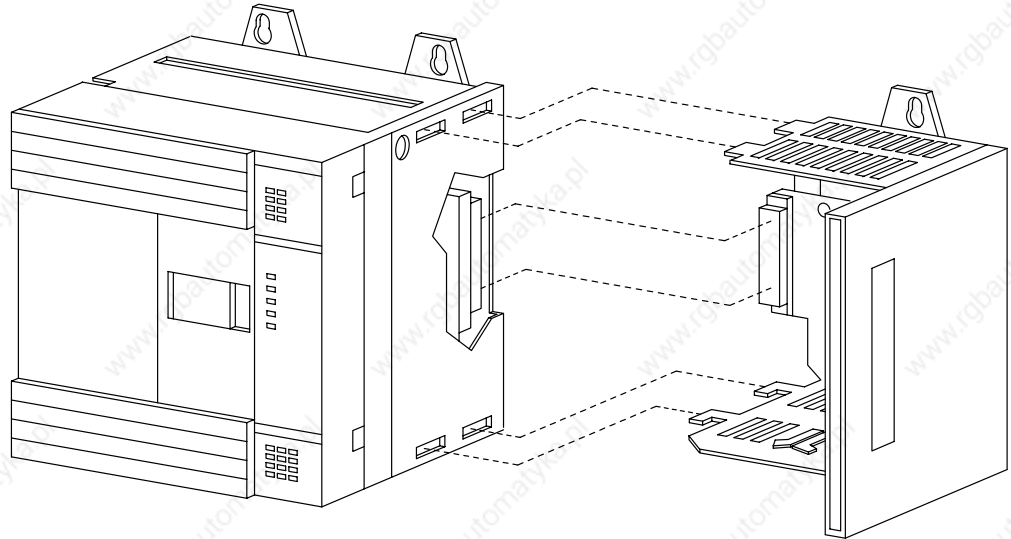

19528

Installing I/O and Speciality Modules

With the 2-slot expansion chassis on the fixed style unit, additional I/O and specialty modules can be supported.



ATTENTION: Never install, remove, or wire modules with power applied to the chassis.

1. Align circuit board of the module with card guide in chassis.

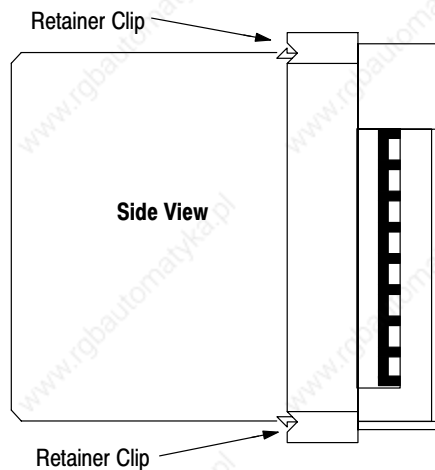

-
- 2. Gently slide the module in until both top and bottom retainer clips are secured.**

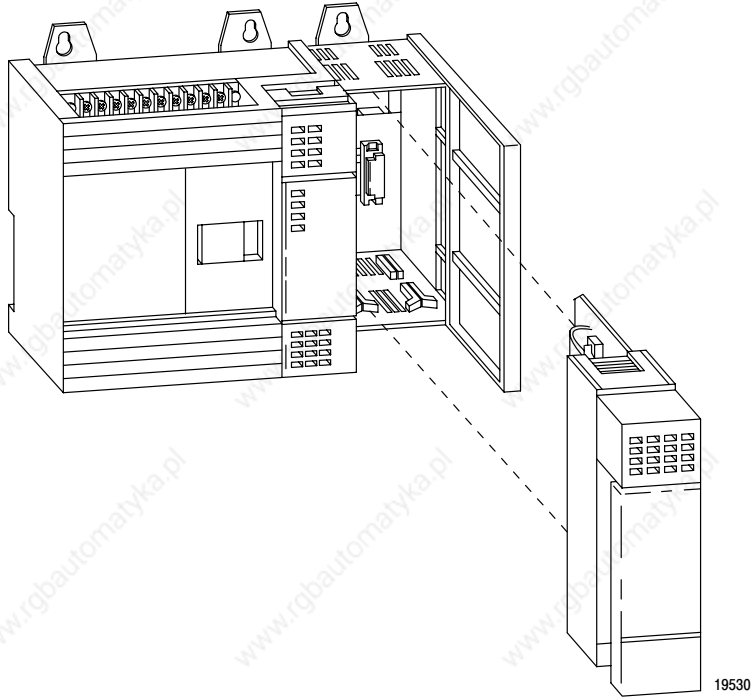

-
-
- 3. To remove the module, press the retaining clips at the top and bottom of the module and slide the module out.**

Installing Your Memory Module

Always turn off power to the controller before inserting or removing the memory module. This guards against possible damage to the module and also undesired processor faults. Memory modules are mounted in carriers and have connectors that are “keyed” to guard against improper installation.



ATTENTION: To avoid potential damage to the memory modules, handle them by the ends of the carrier or edges of the plastic housing. Skin oil and dirt can corrode metallic surfaces, inhibiting electrical contact. Also, do not expose memory modules to surfaces or areas that may hold an electrostatic charge. Electrostatic charges can alter or destroy memory.

1. Always turn off power to the controller before inserting or removing the memory module. This guards against possible damage to the module and also undesired processor faults.



ATTENTION: When power is applied to the controller hazardous electrical potentials exist under the front cover. See page 2–8 for more information.

2. Remove the processor compartment cover.
3. Locate the socket on the PC board.

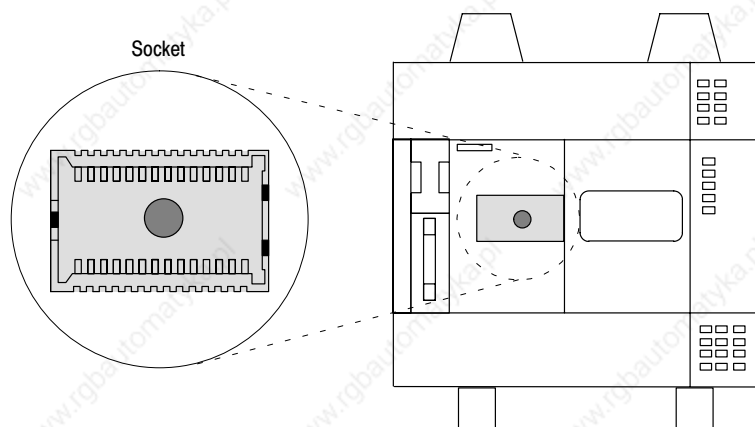

4. Position the module correctly over the socket and press it firmly in place. (The memory module is keyed.)



5. Replace the cover on the SLC controller and restore power.

Removing Your Memory Module

To remove a memory module use the following procedure:

1. Remove the power from the fixed I/O unit.
2. Remove the processor compartment cover.
3. Grasp the carrier tabs with the thumb and index fingers, then gently but firmly lift upwards on either end of the memory module carrier.
4. When the end is partially raised, begin lifting the other end in the same manner. Repeat this until the memory module has been completely removed from the socket.
5. Replace processor cover.

Using the High-Speed Counter

The fixed I/O units that have 24 VDC input circuits are also equipped with a high-speed counter. The counter is capable of counting at a rate of up to 8 kHz.

You have the option of using input 0 as a normal input or as a high-speed counter. To accommodate this dual function the input is equipped with a jumper selectable filter. You must cut the jumper for high-speed counter use. A shielded cable is recommended to reduce noise to the input.

High-Speed Counter Operation

For high-speed counter operation do the following:

1. Turn off power to the fixed controller.



ATTENTION: When power is applied to the controller hazardous electrical potentials exist under the front cover. See page 2–8 for more information.

2. Remove the SLC 500 cover.
3. Locate and cut jumper wire J2. The jumper is either beneath or to the right of the battery connector, as shown below. Do not remove completely but make certain that the ends of the cut jumper wire are not touching each other.

Chapter 4

Installing Your Hardware Components

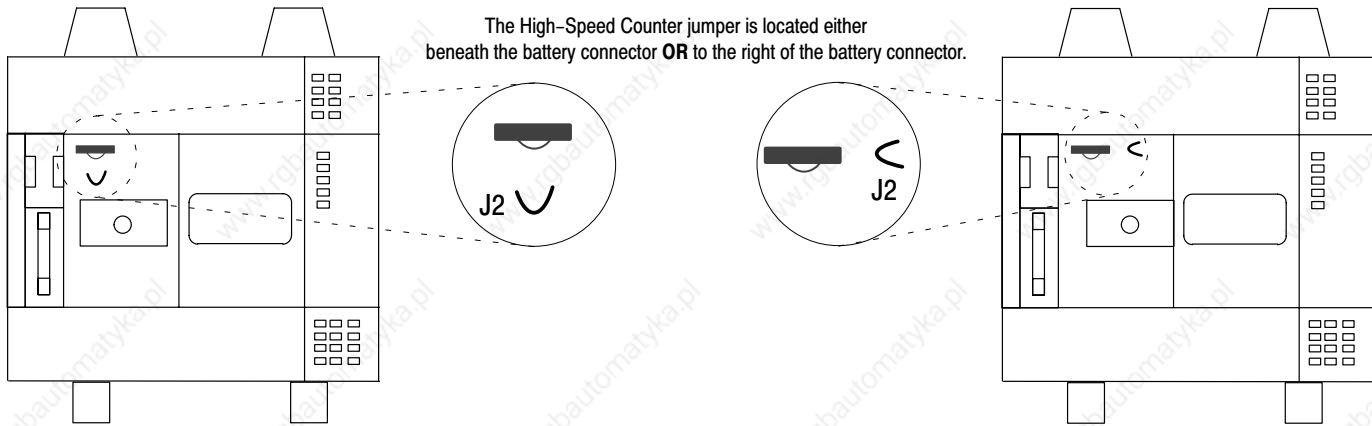

4. Replace the cover.

High-Speed Counter Input Compatibility

The high-speed counter input circuit has the following characteristics:

- nominal input impedance of $\approx 1200 \Omega$
- on-state voltage of 10–30 VDC
- nominal input current draw of 20mA
- minimum pulse width of 62.5 μsec .

Your input device or encoder must be single-ended and be compatible with the specifications of the high-speed counter input. See the table below for more information.

For an Input Device or Encoder that Is	Use an HSC Input Circuit that Is
Sourcing	Sinking
Open Collector/ Sinking	Sourcing
Open Collector with Pull-up Resistor	Sinking

Wiring Diagram of a High-Speed Counter Sinking Input Circuit

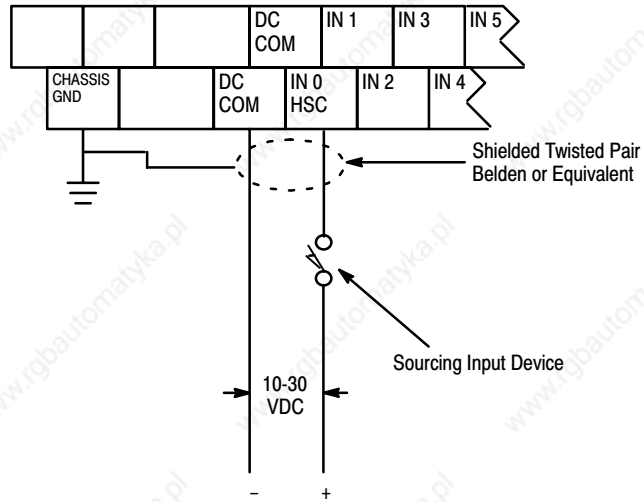

Wiring Diagram of a High-Speed Counter Sourcing Input Circuit

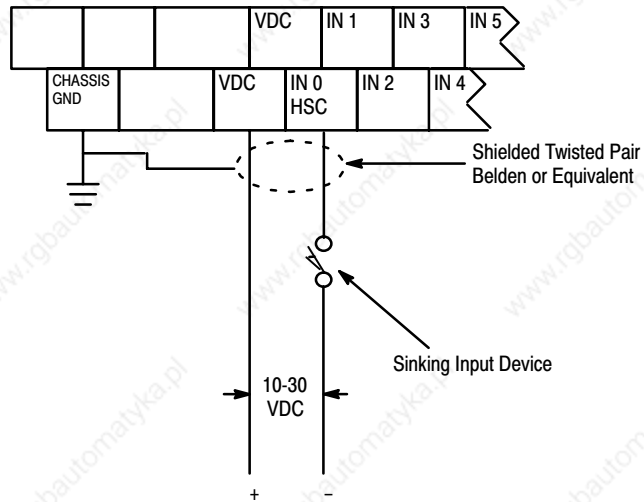

Wiring Your Control System

This chapter describes how to wire your I/O modules. It covers the following:

- defining sinking and sourcing
- determining approximate transient duration
- preparing your wiring layout
- features of an I/O module
- recommendations for wiring I/O devices
- wiring your I/O modules
- using Removable Terminal Blocks (RTBs)

Defining Sinking and Sourcing

Sinking and sourcing are terms used to describe a current signal flow relationship between field input and output devices in a control system and their power supply.

- Field devices connected to the positive side (+V) of the field power supply are sourcing field devices.
- Field devices connected to the negative side (DC Common) of the field power supply are called sinking field devices.

To maintain electrical compatibility between field devices and the programmable controller system, this definition is extended to the input/output circuits on the discrete I/O modules.

- Sourcing I/O circuits supply (source) current to sinking field devices.
- Sinking I/O circuits receive (sink) current from sourcing field devices.

Contact Output Circuits — AC or DC

Relays can be used for either AC or DC output circuits and accommodate either sinking or sourcing field devices. These capabilities are a result of the output switch being a mechanical contact closure, not sensitive to current flow direction and capable of accommodating a broad range of voltages.

This high degree of application flexibility makes contact output modules very popular and useful in control environments with a broad mix of electrical I/O circuit requirements.

Solid-State DC I/O Circuits

The design of DC field devices typically requires that they be used in a specific sinking or sourcing circuit depending on the internal circuitry of the device.

Sourcing Device with Sinking Input Module Circuit

The field device is on the positive side of the power supply between the supply and the input terminal. When the field device is activated, it sources current to the input circuit.

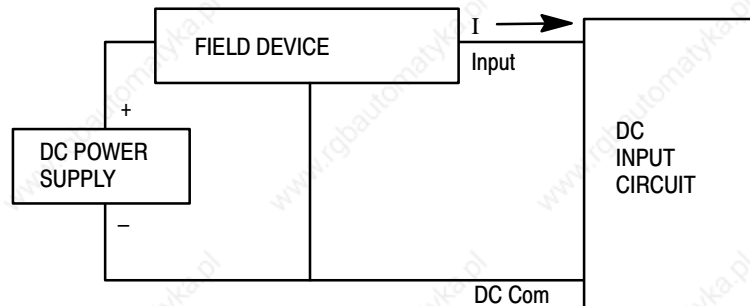

Sinking Device with Sourcing Input Module Circuit

The field device is on the negative side of the power supply between the supply and the input terminal. When the field device is activated, it sinks current from the input circuit.

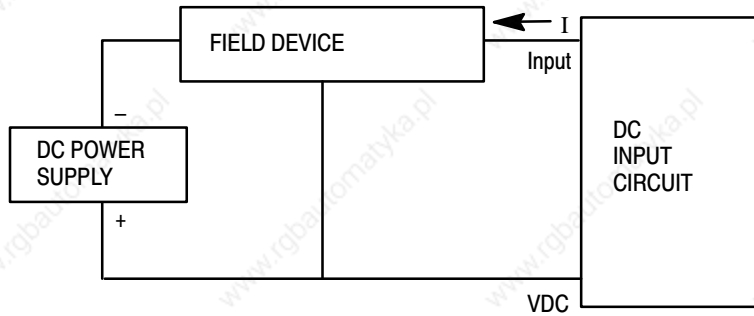

Sinking Device with Sourcing Output Module Circuit

The field device is on the negative side of the power supply between the supply and the output terminal. When the output is activated, it sources current to the field device.

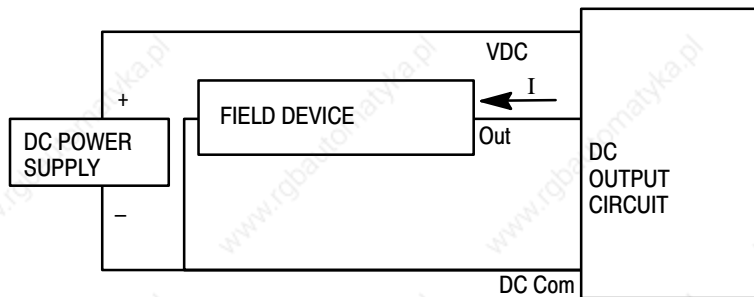

Sourcing Device with Sinking Output Module Circuit

The field device is on the positive side of the power supply between the supply and the output terminal. When the output is activated, it sinks current from the field device.

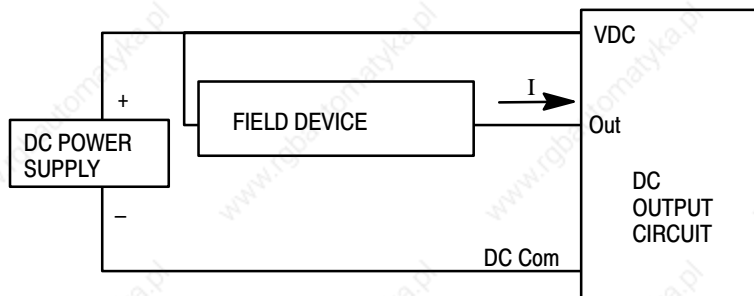

Preparing Your Wiring Layout

Careful wire routing within the enclosure helps to cut down electrical noise between I/O lines. Follow these rules for routing your wires:

- Route incoming power to the controller by a separate path from wiring to I/O devices. Where paths must cross, their intersection should be perpendicular.

Important: Do not run signal or communications wiring and power wiring in the same conduit.

- If wiring ducts are used, allow for at least two inches between I/O wiring ducts and the controller. If the terminal strips are used for I/O wiring, allow for at least two inches between the terminal strips and the controller.
- Segregate I/O wiring by signal type. Bundle wiring with similar electrical characteristics together.

Wires with different signal characteristics should be routed into the enclosure by separate paths.



ATTENTION: If the controller is being installed within a potentially hazardous environment (that is, Class I, Division 2), all wiring must comply with the requirements stated in the National Electrical Code 501-4 (b).

Features of an I/O Module

Below is an example of a combination I/O module.

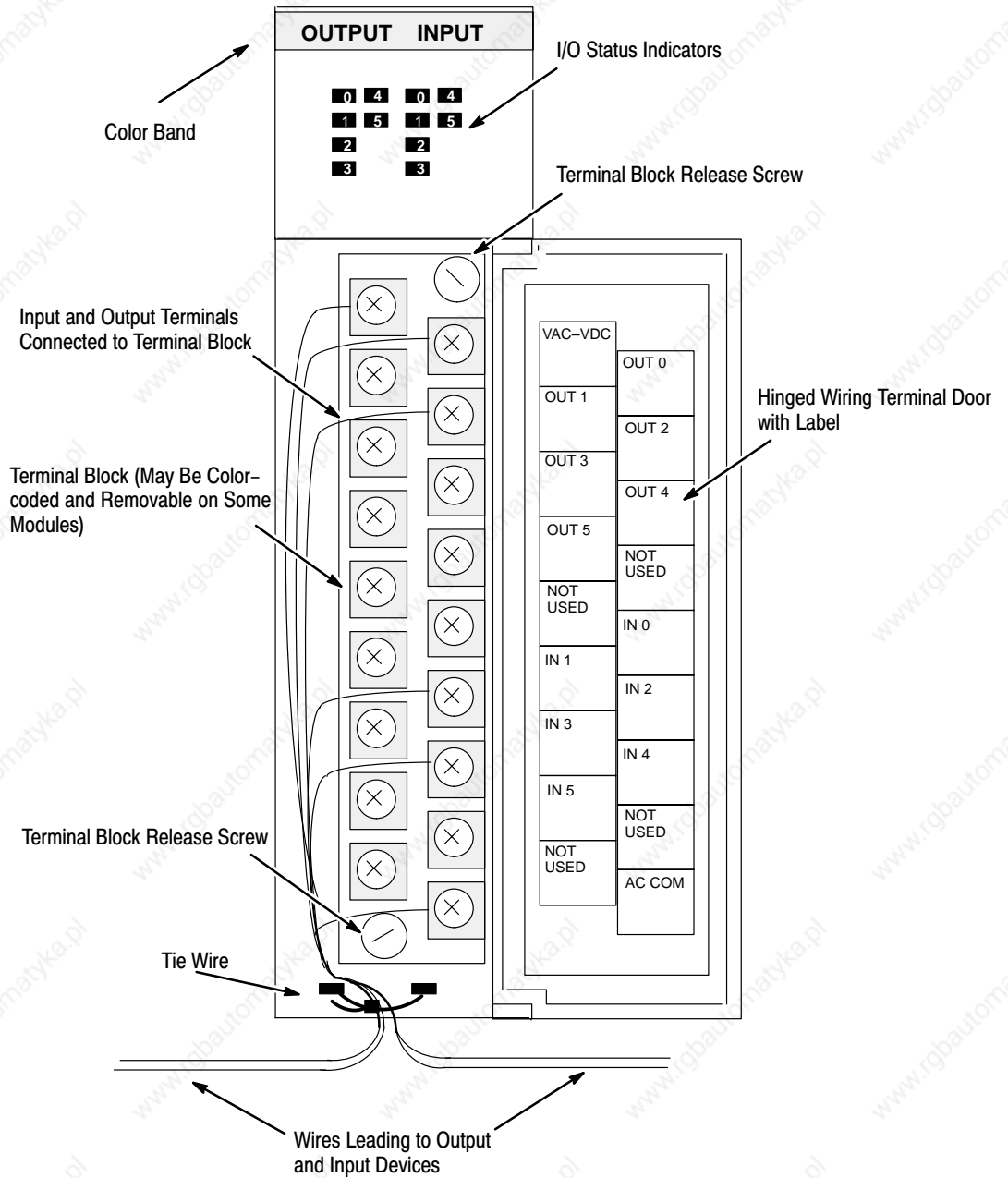

Recommendations for Wiring I/O Devices

The following are general recommendations for wiring I/O devices.



ATTENTION: Before you install and wire I/O devices, disconnect power from the controller and any other source to the I/O devices.

Use acceptable wire gauge — The I/O wiring terminals are designed to accept #14 or smaller AWG stranded wires, and two wires per terminal (maximum). Maximum torque 0.9 N·m (8 in·lb).

Label wires — Label wiring to I/O devices, power sources, and ground. Use tape, shrink-tubing, or other dependable means for labeling purposes. In addition to labeling, use colored insulation to identify wiring based on signal characteristics. For example, you may use blue for DC I/O wiring and red for AC I/O wiring.

Bundle wires — Bundle wiring for each similar I/O device together. If you use ducts, allow at least 5 cm (2 in.) between the ducts and the controller so there is sufficient room to wire the devices.

Identify terminals — Terminal cover plates have a write-on area for each terminal. Use this area to identify your I/O devices. Label the Removable Terminal Block (RTB) with appropriate slot, rack (chassis) and module identification if you have not already. Refer to page 5–8 for more information.



ATTENTION: Calculate the maximum possible current in each power and common wire. Observe all local electrical codes dictating the maximum current allowable for each wire size. Current above the maximum ratings may cause wiring to overheat, which can cause damage.

Capacitors on input modules have a stored charge that can cause a non-lethal shock. Avoid mounting the controller in a position where installation or service personnel would be in danger from startle reaction.

Wiring Your I/O Modules

Terminals on the modules have self-lifting pressure plates that accept two #14 AWG wires. Series B 12-point and 16-point and analog modules are equipped with removeable terminal blocks (RTBs) for ease of wiring. For more information on using RTBs, see the next section.

LED indicators on the front of each module display the status of each I/O point. The LED indicators turn on when the proper signal to an input terminal is applied or when the processor commands an output to be energized.

To locate the I/O module wiring diagrams, contact your Allen-Bradley sales office for the latest product data entitled *Discrete Input and Output Modules*, Publication Number 1746-2.35. Or, locate the installation instruction sheet that was sent with your I/O module; it also includes I/O wiring diagrams.

1. Install a wire tie to secure your wiring and keep it neat. (If you feed the tie into one hole, it will be routed back out through the other.)

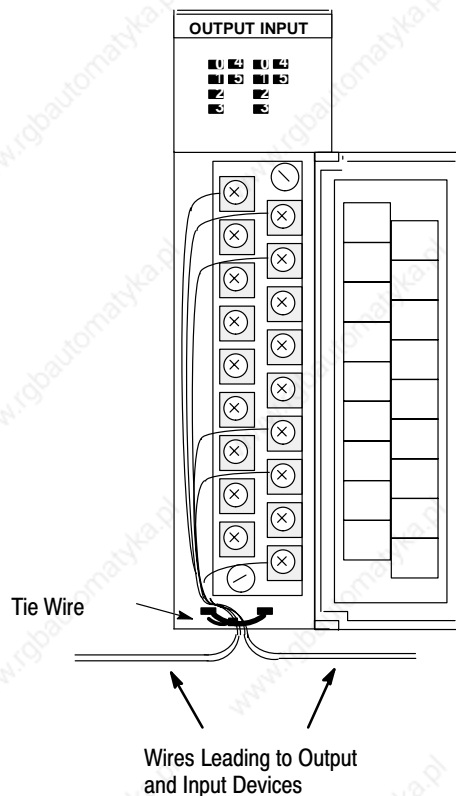

2. Cover any unused slots with card slot fillers, Catalog Number 1746-N2, to keep the chassis free from debris and dust.

Using Removable Terminal Blocks (RTBs)

Removable Terminal Blocks (RTBs) are provided on all 12–point and 16–point discrete I/O modules and analog modules. RTBs can only be used with these modules in the 2–slot expansion chassis. RTBs allow for faster and more convenient wiring of the I/O modules. The modules and RTBs are color–coded as follows:

Color	Type of I/O Removable Terminal Block
Red	AC inputs/outputs
Blue	DC inputs/outputs
Orange	relay outputs
Green	specialty modules

Replacement terminal blocks are available if they are lost or damaged. See the replacement part list in chapter 9.

Removing RTBs

Below are guidelines for removing the I/O RTBs.



ATTENTION: Never install or remove I/O modules or terminal blocks while the SLC is powered.

1. If the I/O module is already installed in the chassis, remove power to the SLC.
2. Unscrew the upper right and lower left terminal block release screws.
3. Grasp the RTB with your thumb and forefinger and pull straight out.
4. Label the RTB with appropriate slot, rack (chassis) and module identification.

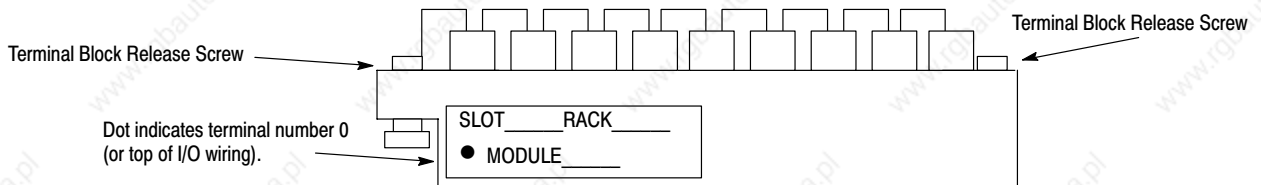

Installing RTBs

Below are guidelines for installing the I/O RTBs.

1. Label the RTB properly.
2. Match the label identification to the correct chassis, slot, and module type.



ATTENTION: Inserting a wired RTB on an incorrect module can damage the I/O module circuitry when power is applied.

-
3. Be sure the color band on the I/O module matches the color of the RTB.



ATTENTION: Never install or remove I/O modules or RTBs while the SLC 500 chassis is powered.

-
4. Remove power from the SLC 500 chassis.
 5. Line up terminal block release screws.
 6. Press the RTB firmly onto connector contacts.
 7. Tighten the RTB release screws.

Starting Up Your Control System

This chapter describes how to start up your control system. To accomplish this, you must go through eight procedures.

Procedures for Starting Up the Control System

Start-up involves the following procedures to be carried out in sequence:

1. Inspect your installation.
2. Disconnect motion-causing devices.
3. Initialize and test your processor.
4. Test your inputs.
5. Test your outputs.
6. Enter and test your program.
7. Observe control motion.
8. Conduct a dry run of your application.

These procedures isolate problems such as wiring mistakes, equipment malfunction, and programming errors in a systematic, controlled manner.

We urge you to go through these procedures very carefully. This will help you avoid possible personal injury and equipment damage.

Important: Do not attempt system start-up until you are thoroughly familiar with the controller components and programming/editing techniques. You must also be thoroughly familiar with the particular application.

For general recommendation concerning installation safety requirements and safety requirements and safety related work practices, refer to NFPA 70E, *Electrical Safety Requirements for Employee Workplaces*.

1. Inspect Your Installation

You can often prevent serious problems in later test procedures by first making a thorough physical inspection. We recommend that you do the following:

1. Make sure that the controller and all other devices in the system are securely mounted. Refer to chapter 3 and chapter 4 for more information.
2. Check all wiring including:
 - connections from the main disconnect to the controller input
 - the master control relay/emergency–stop circuit
 - input device circuits
 - output device circuits

Make certain that all wiring connections are correct and that there are no missing wires. Check the tightness of all terminals to make certain wires are secure. Refer to chapter 5 for more information.

3. Measure the incoming line voltage. Be certain that it corresponds to controller requirements and that it falls within the specified voltage range. See specifications for input voltage ranges in chapter 1.

2. Disconnect Motion-causing Devices

In the following test procedures, the controller will be energized. As a safety precaution, you must make certain that machine motion will not occur. The preferred way is to disconnect the motor wires at the motor starter or the motor itself. In this way, you can test the operation of the starter coil, verifying that your output circuit is wired correctly and functioning. Similarly, the preferred way to disconnect a solenoid is to disengage the valve, leaving the coil connected.

In some instances, you may not be able to disconnect a device the preferred way. In this case, it will be necessary to open the output circuit at some convenient point.

For circuit testing purposes, it is best to open the circuit at a point as close as possible to the motion-causing device. For example, your output might be a relay coil that in turn energizes a motor starter; if it is impractical to disconnect the motor wires, the next best thing to do is to open the circuit at a point between the motor starter and the relay contact.



ATTENTION: Machine motion during system checkout can be hazardous to personnel. During the checkout procedures 3, 4, 5, and 6, you must disconnect all devices that, when energized, might cause machine motion.

3. Initialize and Test Your Processor

When you are certain that machine motion cannot occur with the controller energized, you may begin by initializing the processor using the following steps:

1. Energize the controller. If power is supplied to the controller and the installation is correct, then:

A. The POWER LED turns on as shown in the figure below.

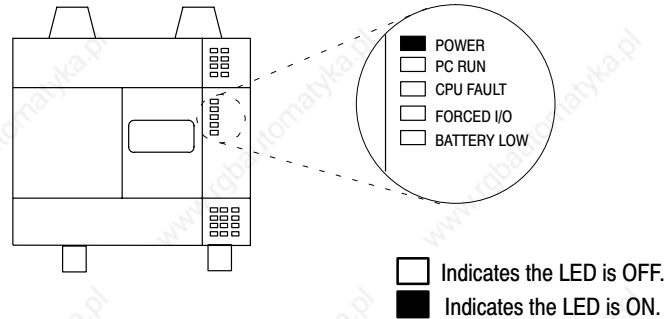

The CPU FAULT LED also turns on during power-up, but it should go off after a few seconds. If instead this LED starts flashing, it indicates you must clear the processor memory before continuing.

B. The following processor initial factory conditions apply:

- Mode = PROGRAM MODE
(S:1/0 – S:1/4 = 0 0001)
- Watchdog values = 100ms
(S:3H = 0000 1010)
- I/O Slot enables = ALL ENABLED
(S:11/1 through S:12/14 set to 1)
- Node address = 1
(S:15L = 0000 0001)
- Baud Rate = 19.2K baud
(S:15H = 0000 0100)
- Processor Name = DEFAULT

2. Power up the programming device.

Refer to the *Hand-Held Terminal User Manual*, Catalog Number 1747-NP002, for information on programming your fixed controller with the HHT.

Refer to the *Advanced Programming Software User Manual*, Catalog Number 1747-NM002 Series C, and the *Advanced Programming Software Reference Manual*, Catalog Number 1747-NR001, for information on programming your fixed controller with APS.

3. Configure the controller.

4. Name the processor file.

5. Program a sample test rung not affecting machine operation.

6. Save the program and the controller configuration.

7. Transfer the controller configuration and the sample test program to the processor. After the new program is transferred to the processor, the processor fault status should clear. (The CPU FAULT LED stops if it was flashing.)

8. Enter the Run mode.

The processor PC RUN LED should turn on indicating the controller is in the RUN mode with no processor faults. If any other processor status exists, refer to chapter 8.

9. Monitor the sample test rung.

If the sample test rung operates successfully without processor faults, you have verified that basic processor functions are properly functioning. If any other processor status exists, refer to chapter 8.

4. Test Your Inputs

After successful processor initialization and test, you may begin testing inputs following these steps:

1. Assuming you are still online with the programming device, put the controller into the Continuous Test mode. This allows the processor to scan the I/O and program, but not turn on any physical outputs.
2. Monitor the data in data File 1, the input data file. All configured inputs should be displayed.
3. Make sure the first input slot, slot 0, is shown on the monitor.
4. Select the first input device connected to Input 0 of the fixed I/O chassis.
5. Manually close and open the addressed input device.



ATTENTION: Never reach into a machine to actuate a device, unexpected machine operation could occur.

6. Observe the associated bit status using the programming device monitor function. Also, observe the input status LED on the fixed I/O chassis.
 - A. When the input device is closed verify that the voltage at the input terminal is within the specified on-state range, the input status LED is on, and the associated status bit is set to a one.

If any of these conditions are not satisfied, follow the recommended troubleshooting steps listed below.
 - B. When the input device is opened verify that the voltage at the input terminal is within the specified off-state range, the input status LED is off, and the associated status bit is reset to 0.

If any of these conditions are not satisfied, follow the recommended troubleshooting steps listed below.
7. Select the next input device and repeat steps 5 and 6 until all inputs on the fixed I/O chassis and in the 2-slot expansion rack (if used) have been tested.

Input Troubleshooting Steps

1. Make sure the processor is in the Continuous Test mode.
2. Verify that your inputs and outputs are enabled. Status file bit S:11/0 represents the inputs and outputs of the fixed controller. Status file bits S:11/1 and S:11/2 represent the inputs and outputs (slot 1 and slot 2 respectively) of the 2-slot expansion chassis. These bits must be set to one, enabling all your inputs and outputs.
3. Check your wiring and verify that all connections are tight.
 - A. Make sure that power connections have been made to your input device if needed.
 - B. Verify that the signal connection has been made from the input device to the correct input circuit of the fixed controller.
 - C. Check that all common connections have been made.
4. Check your specifications.
 - A. Make sure that the power is within the specified voltage range if your input device requires power.
 - B. Verify that your power supply is not overloaded. An overloaded supply can deliver the correct voltage when some of its loads are not energized but the voltage may fall out of range when all of its loads are energized.
 - C. Verify that your input device signal contact is specified to deliver sufficient current to the input circuit and any other loads connected to it.
 - D. Make certain that your input device does not have a minimum load specification that is greater than the input circuit current specification.
 - E. Verify that the input device is on and off longer than the specified turn-on and turn-off times for the input circuit.

5. Disconnect your input devices from the fixed controller input terminals. Make a direct connection from a power supply to the fixed controller input and common terminals. The power supply voltage must be within the specified on-state voltage range of the input circuit. If you can energize and de-energize the input circuit by turning the power supply on and off, the basic operation of the input circuit is functioning correctly. The problem is likely to be with the input device or wiring. If you cannot operate the the input circuit by a direct connection, the input circuit is not functioning and should be replaced.
6. Connect a different load to your input device. Open and close the input device and measure the voltage at the load. If your input device cannot operate other loads, the input device is not functioning properly and should be replaced.

For more information on input troubleshooting, see page 8–8.

5. Test Your Outputs

After you test all inputs, and have determined that they are functioning properly, test the outputs following these steps.

1. Refer to page 6–2 to insure that no motion will occur when any controller output is energized.
2. Place the controller in the Program mode.
3. Create an output test rung as shown below for each output slot configured. Enter your source and destination address:

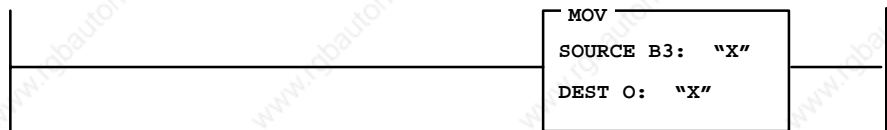

Here “X” represents the slot number of the output currently selected. This rung moves a word of data from the bit file to the output file. The slot number is 0 for outputs of the fixed controller. If the 2–slot expansion chassis is used, numbers one and two are used for the outputs in slots 1 and 2 respectively.

4. Save the output test program and controller configuration.
5. Transfer the output test program to the processor.
6. Put the controller in the Run mode.
7. Monitor the data in bit file B3 on the programming device display.
8. Enter **B3: “X”** at the address prompt to select the output slot to be tested.
9. Move the cursor to the bit position that corresponds to the specific output being tested. Set the bit to 1.

10. Observe the output status LED and the output device.

The output status LED should turn on. The output device should be energized unless you disconnected it to prevent machine motion. It may be necessary to connect a dummy load to the output to complete this test. If the LED does not turn on or if the load is not energized, follow the output troubleshooting steps listed below.

11. Reset the bit value back to zero for the selected address. Both the output status LED and the output device should de-energize. If the LED does not turn off or if the load does not de-energize, follow the output troubleshooting steps listed below.

12. Repeat steps 9 through 11 for all outputs of the selected slot.

13. Repeat steps 8 through 12 for all slots (with outputs) that are a part of the fixed controller configuration.

Output Troubleshooting Steps

1. Make sure the processor is in the Run mode.
2. Verify that the test rung recommended in the previous section has been entered correctly.
3. Check the status file I/O slot enable bits. Status file bit S:11/0 represents the inputs and outputs of the fixed controller. Status file bits S:11/1 and S:11/2 represent the inputs and outputs (slot 1 and slot 2 respectively) of the 2-slot expansion chassis. These bits must be set to one, enabling all your inputs and outputs.
4. Use a programming device to verify that the bit being tested in the output file tracks the on/off status of the corresponding bit in the bit file.

If the output file does not track the bit file, but your program has been entered correctly and the I/O are enabled, then your processor is not functioning properly and should be replaced.

If the output file tracks the bit file, then the processor is functioning properly and the output command is being sent to either the I/O section of the fixed controller, or to the output module in the 2-slot expansion chassis.

5. Check the electrical connections.
 - A. If the output being tested is in the 2-slot expansion chassis, verify that the expansion chassis connector is properly mated to the expansion connector of the fixed controller.
 - B. Turn off power to the I/O circuits. Verify that power and/or common connections are made to the proper output circuit terminals.
 - C. Verify that the power connections are made to the output load device if they are required.
 - D. Verify that the output terminal being tested is connected to the correct termination point of the load device.
 - E. Check the tightness of all terminals to make certain that all wires are secure.

6. Check your specifications.
 - A. Verify that all power supplies used are within the specified operating ranges of the I/O circuits and loads.
 - B. Check that the specified load current is greater than the minimum load current specified for the output circuit. (Leakage current from the output circuit may prevent you from turning off a low current load.)
 - C. Check that the specified load current is less than the maximum load current of the output circuit.
 - D. Make sure that the sum of all the load currents is equal to or less than the power supply capacity.
7. Restore power to the I/O circuits and test the output. If the preceding measures have not corrected the problem, turn off the I/O power and disconnect the load. Connect the load directly to the I/O power supply. You should be able to operate the load by turning the power supply on and off.

If you can operate the load, and the load is within the specified operating range of the output circuit, the output circuit is not functioning properly. Replace the fixed controller or output module as necessary.

If you cannot operate the load by turning the power supply on and off, the load is not operating properly and it should be replaced.

For more information on output troubleshooting, refer to page 8–10.

6. Enter and Test Your Program

After you test all inputs and outputs and they are functioning properly, we recommend the following steps to safely and successfully enter and test your specific application program. (For extra assistance, see the *Hand-Held Terminal User Manual* or the *Advanced Programming Software User Manual*.)

1. Verify the offline program.

After the program has been entered in the offline edit file mode, program verification may begin.

Remaining in the offline edit file mode you may use the cursor keys and/or search function of your programming device to inspect every instruction and rung for errors.

2. Check your written program, rung for rung, against the program entered into the offline memory. The most common errors found in program entry are:
 - incorrect addressing of instructions
 - omission of an instruction
 - more than one output instruction programmed using the same address

3. Transfer the program into the processor.
 - A. Place your programming device online.
 - B. Place the processor in Program mode.
 - C. Select download function when using the Hand-Held Terminal or the restore function when using Advanced Programming Software.
4. Verify the online program transfer.
 - A. Select monitor file function.
 - B. Cursor through the program to verify that you selected the right program.
5. Conduct a single-scan program test.
 - A. Select the monitor file function and place the cursor on the first rung.
 - B. Select the Test mode.
 - C. Select Single-Scan (SSN) test. In this test mode, the processor executes a single operating cycle, which includes reading the inputs, executing the ladder program, and updating all data without energizing the output circuits. However, the monitor file function will identify the output status as if the outputs were enabled.

Timers are also incremented a minimum of 10 milliseconds each single scan.
 - D. Simulate the input conditions necessary to execute the current monitored rung of the program. If it is not practical to manually activate the input device, use the force function to simulate the proper condition.



ATTENTION: Never reach into a machine to actuate a device, unexpected machine operation could occur.

- E. Activate a single operating scan as outlined in the programming device user manual.
 - F. Verify the intended effects on the output instructions for that rung and overall program logic effects.
 - G. Select the next program rung and repeat test procedures as listed above until the entire program has been tested.
6. Conduct a continuous scan program test.

Once the individual single scan rung tests have been completed and proper program operation verified, a continuous scan test might be appropriate before motion checkout.

This mode simulates the controller Run mode without energizing the external outputs.

7. Observe Control Motion

Now that program execution has been verified, checkout of control motion can begin. All persons involved with the programming, installation, layout design, machine or process design, and maintenance should be involved in making decisions for determining the best and safest way to test the total system.

The following procedures are general in nature. Individual conditions may warrant their modification. The basic approach is to initiate testing with the least amount of machine motion. Only some outputs are allowed to generate machine motion. Then additional machine motion can be gradually added, thereby allowing any problems to be detected more easily under controlled conditions. The following procedure provides the steps for testing machine motion using one output at a time.



ATTENTION: During all phases of checkout, station a person ready to operate an emergency-stop switch if necessary. The emergency-stop switch will de-energize the master control relay and remove power from the machine. This circuit must be hardwired only, it *must not* be programmed.

Use the following procedures:

1. Identify the first output device to be tested and reconnect its wiring.



ATTENTION: Contact with AC line potential may cause injury to personnel. When reconnecting wiring, make sure that AC power disconnect switch is opened.

2. Place the controller in the Run mode and observe the behavior of the output device. To do this, simulate the input conditions necessary to energize the output in the program. If it is not practical to manually activate an input device, use the force function to simulate the proper input condition.



ATTENTION: Never reach into a machine to actuate a device, unexpected machine operation could occur.

3. Repeat steps 1 and 2, testing each output device, one at a time.

8. Conduct a Dry Run



ATTENTION: During all phases of the dry run test, station a person ready to operate an emergency–stop switch if necessary. The emergency–stop switch will de–energize the master control relay and remove power from the machine. This circuit must be hardwired only, it *must not* be programmed.

After thoroughly checking out the controller system and program, proceed with a dry run of the application with all of the output devices enabled. This dry run will vary with the application. For example, a machine tool dry run might test the program with all outputs enabled but without tooling an actual part.

After you check out the entire system, and your dry run has been completed satisfactorily, we recommend that you load your program into an EEPROM memory module for back–up program storage. See chapter 3 for more information. Refer to the *Hand–Held Terminal User Manual*, Catalog Number 1747–NP002, or the *Advanced Programming Software User Manual*, Catalog Number 1747–NM002, for directions on loading the EEPROM from RAM.

This step completes the start–up procedures. Your SLC Programmable Controller is now ready for operation.

Maintaining Your Control System

This chapter covers the following:

- handling, storing, and transporting battery, Catalog Number 1747-BA
- installing or replacing your SLC 500 battery
- replacing the power supply fuse
- replacing retainer clips on a module

Refer to chapter 2 for important information on testing the master control relay circuit and preventive maintenance.

Handling, Storing, and Transporting Battery, Catalog Number 1747-BA

Follow the procedure below to ensure proper battery operation and reduce personnel hazards.

Handling

- Use only for the intended operation.
- Do not ship or dispose of batteries except according to recommended procedures.
- Do not ship on passenger aircraft.



ATTENTION: Do not charge the batteries. An explosion could result or they could overheat causing burns.

Do not open, puncture, crush, or otherwise mutilate the batteries. A possibility of an explosion exists and/or toxic, corrosive, and flammable liquids would be exposed.

Do not incinerate or expose the batteries to high temperatures. Do not attempt to solder batteries. An explosion could result.

Do not short positive and negative terminals together. Excessive heat could build up and cause severe burns.

Storing

Store the lithium batteries in a cool, dry environment, typically +20° C to +25° C (+68° F to +77° F) and 40% to 60% relative humidity. Store the batteries and a copy of the battery instruction sheet in the original container, away from flammable materials.

Transporting

One or Two Batteries – Each battery contains 0.23 grams of lithium. Therefore, up to two batteries can be shipped together within the United States without restriction. Regulations governing shipment to or within other countries may differ.

Three or More Batteries – Procedures for the transportation of three or more batteries shipped together within the United States are specified by the Department of Transportation (DOT) in the Code of Federal Regulations, CFR49, “Transportation.” An exemption to these regulations, DOT – E7052, covers the transport of certain hazardous materials classified as flammable solids. This exemption authorizes transport of lithium batteries by motor vehicle, rail freight, cargo vessel, and cargo-only aircraft, providing certain conditions are met. Transport by passenger aircraft is not permitted.

A special provision of DOT–E7052 (11th Rev., October 21, 1982, par. 8–a) provides that:

“Persons that receive cell and batteries covered by this exemption may reshipe them pursuant to the provisions of 49 CFR 173.22a in any of these packages authorized in this exemption including those in which they were received.”

The Code of Federal Regulations, 49 CFR 173.22a, relates to the use of packaging authorized under exemptions. In part, it requires that you must maintain a copy of the exemption at each facility where the packaging is being used in connection with shipment under the exemption.

Shipment of depleted batteries for disposal may be subject to specific regulation of the countries involved or to regulations endorsed by those countries, such as the IATA Restricted Articles Regulations of the International Air Transport Association, Geneva, Switzerland.

Important: Regulations for transportation of lithium batteries are periodically revised.



ATTENTION: Do not incinerate lithium batteries in general trash collection. Explosion or violent rupture is possible. Batteries should be collected for disposal in a manner to prevent against short circuiting, compacting, or destruction of case integrity and hermetic seal.

For disposal, batteries must be packaged and shipped in accordance with transportation regulations, to a proper disposal site. The U.S. Department of Transportation authorizes shipment of “Lithium batteries for disposal” by motor vehicle only in regulation 173.1015 of CRF49 (effective January 5, 1983). For additional information contact:

U.S. Department of Transportation
Research and Special Programs Administration
400 Seventh Street, S.W.
Washington, D.C. 20590

Although the Environmental Protection Agency at this time has no regulations specific to lithium batteries, the material contained may be considered toxic, reactive, or corrosive. The person disposing of the material is responsible for any hazard created in doing so. State and local regulations may exist regarding the disposal of these materials.

Installing or Replacing Your SLC 500 Battery

Back-up power for RAM is provided by a capacitor that will retain the contents of the RAM for a period of 5 to 30 days. For applications requiring memory back-up for a longer period of time an optional replaceable battery, Catalog Number 1747-BA, is required. The lithium battery provides back-up for approximately five years. A red BATTERY LOW LED turns on when the battery voltage has fallen below a threshold level.

For battery installation or replacement, do the following:

1. Back up your ladder program.
2. Disconnect power to the processor.



ATTENTION: When power is applied to the controller hazardous electrical potentials exist under the front cover. See page 2-8 for more information.

3. Remove the processor cover.
4. If you are:
 - installing a battery in a new processor** (battery never installed before), remove the jumper from the battery socket. Store jumper in safe place for possible future use without battery.
 - replacing an old battery**, unplug the battery connector from the socket. The figure below shows you where to install the battery in a fixed controller.
5. Insert a new or replacement battery in the holder making sure it is held in by the retaining clip.
6. Plug the battery connector into the socket. See the figure below.

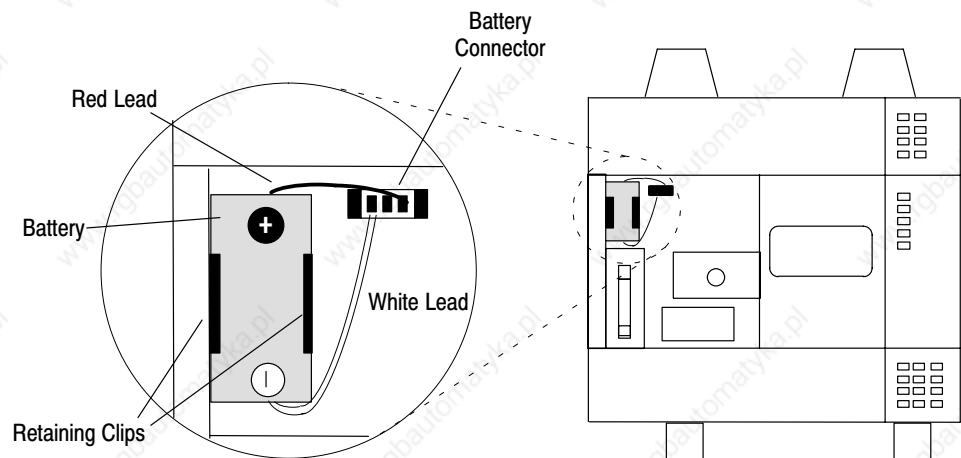

7. Replace the cover.

Replacing the Power Supply Fuse

Under normal power-up conditions, the POWER LED turns on. If a power supply fuse is blown, the POWER LED will not turn on. One of the following conditions could cause a blown power supply fuse:

- excessive line voltage
- internal power supply malfunction
- overloading 2-slot chassis



ATTENTION: Contact with AC line potential can cause injury to personnel. Remove system power before attempting fuse replacement.

Use only replacement fuses of the type and rating recommended for the unit. Improper fuse selection can result in equipment damage.

After the conditions causing the malfunction have been corrected, you can replace the fuse:

1. Disconnect power to the processor.



ATTENTION: When power is applied to the controller hazardous electrical potentials exist under the front cover. See page 2–8 for more information.

2. Remove the cover on the processor.
3. Locate the fuse. Use a miniature fuse puller to grip the fuse and remove it from its holder.
4. Discard the fuse and replace it with the recommended replacement fuse. (See chapter 9 for more information.)

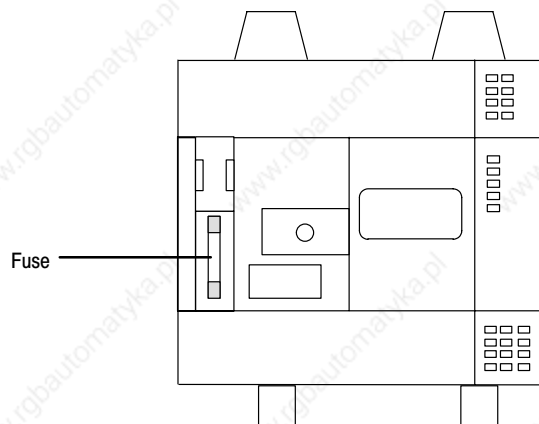

5. Replace the cover on the processor.
6. Restore power to the processor. The POWER LED should now turn on.

Replacing Retainer Clips on an I/O Module

If it becomes necessary to replace the retainer clip (also called self-locking tab), order Catalog Number 1746-R15 (4 clips per package).

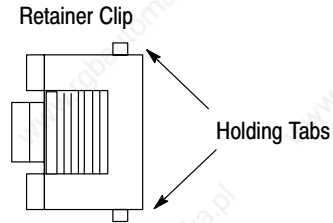

Removing Damaged Retainer Clips

If necessary, pry off the broken retainer clip from the bottom with a screwdriver. Do not twist it off. You can damage the module.

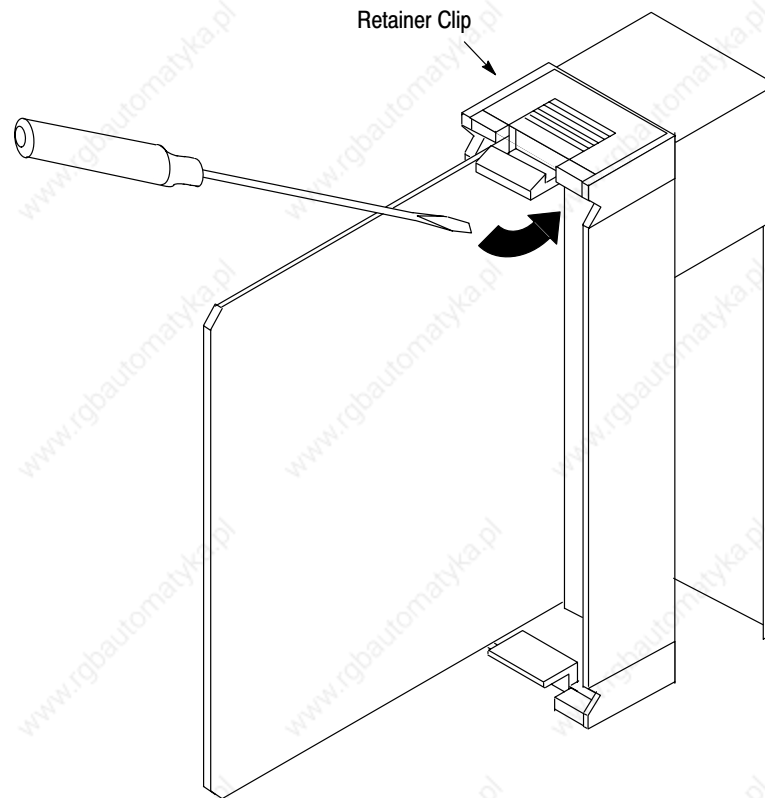

Installing New Retainer Clips

Insert one of the pins of the retainer clip into the hole in the I/O module and then snap the other end in place.

Troubleshooting

In this chapter, you will learn about:

- calling Allen–Bradley for assistance
- tips for troubleshooting your control system
- troubleshooting your fixed controller
- troubleshooting your input modules
- troubleshooting your output modules

Calling Allen–Bradley for Assistance

If you need to contact Allen–Bradley or your local distributor for assistance, it is helpful to obtain the following (prior to calling):

- processor type, series letter, and firmware (FRN) number (see label on side of processor module)
- processor LED status
- processor error codes (found in S:6 of status file)
- hardware types in system (I/O modules, chassis)
- revision of programming device (on the main menu of the Hand–Held Terminal or Advanced Programming Software)

Tips for Troubleshooting Your Control System

When troubleshooting, pay careful attention to these general warnings:



ATTENTION: Have all personnel remain clear of the controller and equipment when power is applied. The problem may be intermittent and sudden unexpected machine motion could result in injury. Have someone ready to operate an emergency-stop switch in case it becomes necessary to shut off power to the controller equipment. Also, see NFPA 70E Part II for additional guidelines for safety related work practices.

Never reach into a machine to actuate a switch since unexpected machine motion can occur and cause injury.

Remove all electrical power at the main power disconnect switches before checking electrical connections or inputs/outputs causing machine motion.

If installation and start-up procedures detailed in chapters 3, 4, and 5 were followed closely, your SLC controller will give you reliable service. If a problem should occur, the first step in the troubleshooting procedure is to identify the problem and its source.

The SLC 500 controller has been designed to simplify troubleshooting procedures. By observing the diagnostic indicators on the front of the processor unit and I/O modules, the majority of faults can be located and corrected. These indicators, along with error codes identified in the programming device user manual and programmer's monitor, help trace the source of the fault to the user's input/output devices, wiring, or the controller.

Removing Power

Before working on a SLC 500 fixed system, always remove the power supply input power at the main power disconnect switch.

The POWER LED on the power supply indicates that DC power is being supplied to the chassis. This LED could be off when incoming power is present when the:

- fuse is blown
- voltage drops below the normal operating range. Refer to chapter 1 for more information.
- power supply is defective

Replacing Fuses

When replacing a fuse, be sure to remove all power from the system.

Program Alteration

There are several causes of alteration to the user program, including extreme environmental conditions, Electromagnetic Interference (EMI), improper grounding, improper wiring connections, and unauthorized tampering. If you suspect the memory has been altered, check the program against a previously saved program on an EEPROM, UVPROM or Flash EPROM module.

Troubleshooting Your Fixed Controller

To receive the maximum benefit of this troubleshooting section, we recommend you follow these steps:

1. Match your processor LEDs with the status LEDs located in the first column in the tables on the following pages.
2. Once the status LEDs are matched to the appropriate table, simply move across the table identifying error description and probable causes.
3. Follow the recommended action steps for each probable cause until the cause is identified.
4. If recommended actions do not identify the cause, contact your local Allen–Bradley sales office or distributor.

Identifying Fixed Controller Errors

Refer to the following key to determine the status of the LED indicators:

- Indicates the LED is OFF.
- Indicates the LED is ON.
- Indicates the LED is FLASHING.

If the LEDs indicate:

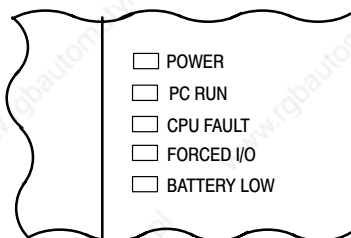

The Following Error Exists	Probable Cause	Recommended Action
Inadequate System Power	No Line Power	Verify proper line voltage and connections on the power terminals.
	Power Supply Fuse Blown	<ol style="list-style-type: none"> 1. Check the incoming power fuse, check for proper incoming power connections. Replace fuse. 2. If fuse blows again, replace the fixed controller.
	Power Supply Overloaded	This problem can occur intermittently if power supply is lightly overloaded when output loading and temperature varies. If you are using a 2-slot chassis, verify the compatibility of the modules to prevent overloading the backplane power.

If the LEDs indicate:

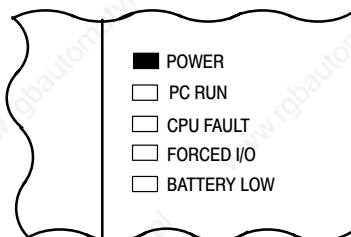

The Following Error Exists	Probable Cause	Recommended Action
Processor Not in Run Mode	Either Improper Mode Selected or User Program Logic Error	<ol style="list-style-type: none"> 1. Verify selected processor mode. 2. If in program/test modes, attempt RUN mode entry. 3. Check user program logic for suspend instructions if in suspend mode. <p>Refer to either the <i>Hand-Held Terminal User Manual</i>, Catalog Number 1747-NP002, or the <i>Advanced Programming Software User Manual</i>, Catalog Number 1747-NM002.</p>
	Line Power Out of Operating Range	<ol style="list-style-type: none"> 1. Check incoming power connections. 2. Monitor for proper line voltage at the incoming power connections.

If the LEDs indicate:

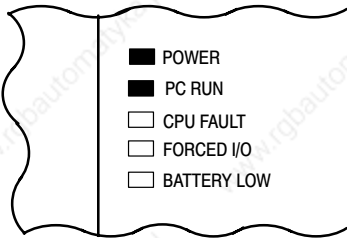

The Following Error Exists	Probable Cause	Recommended Action
System Inoperable, No Major CPU Faults Detected	User Program Logic Error	Monitor logic in Run mode and verify desired I/O status. Refer to either the <i>Hand-Held Terminal User Manual</i> , Catalog Number 1747-NP002, or the <i>Advanced Programming Software User Manual</i> , Catalog Number 1747-NM002.
	Defective I/O Devices or I/O Wiring	Test inputs and outputs according to I/O troubleshooting procedures starting on page 8-8.

If the LEDs indicate:

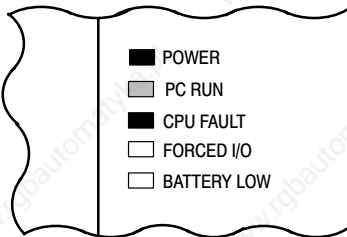

The Following Error Exists	Probable Cause	Recommended Action
CPU Fault	CPU Memory Error	Cycle power.
	Faulty Memory Module	<ol style="list-style-type: none"> 1. Remove power and then remove the memory module from the controller. 2. Re-energize the controller. If steady CPU FAULT LED changes to flashing, replace the existing memory module with a replacement module. Refer to chapter 4 for removing and installing memory modules.
	Processor Firmware Installed Incorrectly	If upgrading the processor to a different firmware level, verify that the firmware chip orientation matches the upgrade kit directions.

Refer to the following key to determine the status of the LED indicators:

- Indicates the LED is OFF.
- Indicates the LED is ON.
- Indicates the LED is FLASHING.

Chapter 8 Troubleshooting

If the LEDs indicate:

■	POWER
□	PC RUN
■	CPU FAULT
□	FORCED I/O
□	BATTERY LOW

The Following Error Exists	Probable Cause	Recommended Action
	Initial CPU Factory Power-up Condition	<ol style="list-style-type: none"> 1. Refer to chapter 6 and follow the start-up procedures. 2. Clear processor memory to get rid of the flashing CPU FAULT LED.
CPU Major Fault	<p>Hardware/Software Major Fault Detected</p> <p>Erratic repetitive power cycling can cause a processor major hardware fault.</p>	<ol style="list-style-type: none"> 1. Monitor Status File Word S:6 for major error code. 2. Refer to either the <i>Hand-Held Terminal User Manual</i>, Catalog Number 1747-NP002, or the <i>Advanced Programming Software User Manual</i>, Catalog Number 1747-NM002, for error codes and additional troubleshooting information. 3. Remove hardware/software condition causing fault. 4. Clear Status File S:1/13 major error bit, if set. 5. Clear Status File S:5 minor error bits, if set. 6. Clear Status File S:6 major error code (optional). 7. Attempt a processor Run mode entry. <p>If unsuccessful, repeat recommended action steps above.</p>

If the LEDs indicate:

■	POWER
■	PC RUN
□	CPU FAULT
■	FORCED I/O
□	BATTERY LOW

The Following Error Exists	Probable Cause	Recommended Action
System does not operate per ladder logic.	User Forced I/O Disabling Operation	<ol style="list-style-type: none"> 1. Monitor program file online and identify forced I/O. 2. Disable appropriate forces and test system conditions again. <p>Refer to either the <i>Hand-Held Terminal User Manual</i>, Catalog Number 1747-NP002, or the <i>Advanced Programming Software User Manual</i>, Catalog Number 1747-NM002.</p>

Refer to the following key to determine the status of the LED indicators:

- Indicates the LED is OFF.
- Indicates the LED is ON.
- Indicates the LED is FLASHING.

If the LEDs indicate:

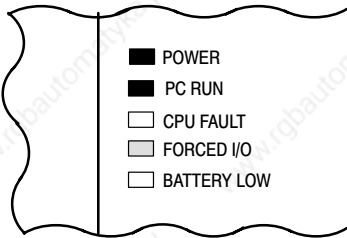

The Following Error Exists	Probable Cause	Recommended Action
System does not operate per programmed forces.	User Programmed Forces are Not Enabled	<ol style="list-style-type: none"> 1. Monitor program file online and identify programmed forces. 2. Enable appropriate forces and test system conditions again. Once forces are enabled, the FORCED I/O LED goes on steady. Refer to either the <i>Hand-Held Terminal User Manual</i> , Catalog Number 1747-NP002, or the <i>Advanced Programming Software User Manual</i> , Catalog Number 1747-NM002.

If the LEDs indicate:

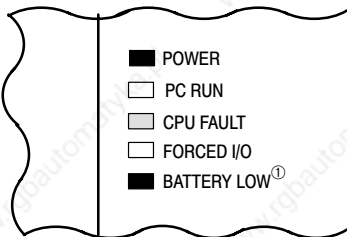

The Following Error Exists	Probable Cause	Recommended Action
CPU Major Error with Low or No Battery Back-up	Loss of RAM during Power Down Period	<ol style="list-style-type: none"> 1. Verify battery is connected. See page 7-4. 2. Replace the battery. See page 7-4. 3. Refer to processor major fault recommended action steps. Refer to either the <i>Hand-Held Terminal User Manual</i> , Catalog Number 1747-NP002, or the <i>Advanced Programming Software User Manual</i> , Catalog Number 1747-NM002.

Refer to the following key to determine the status of the LED indicators:

- Indicates the LED is OFF.
- Indicates the LED is ON.
- Indicates the LED is FLASHING.

^① Regardless of any other LED status indicator conditions, always replace the battery when the BATTERY LOW LED is on if you want RAM battery backup. If you want to back up RAM with a capacitor, add or replace the BATTERY LOW LED jumper.

Troubleshooting Your Input Modules

The following will assist you in troubleshooting your input modules.

Input Circuit Operation

An input circuit responds to an input signal in the following manner:

1. An input filter removes false signals due to contact bounce or electrical interference.
2. Optical isolation protects the backplane circuits by isolating logic circuits from input signals.
3. Logic circuits process the signal.
4. An input LED turns on or off indicating the status of the corresponding input device.

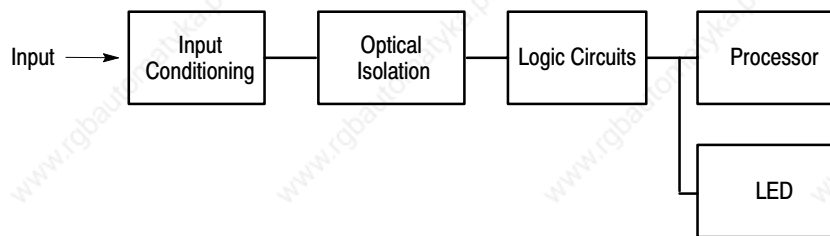

5. The processor receives the input status for use in processing the program logic.

Corrective Action

If your Input Circuit LED is	And Your Input Device is	And	Probable Cause	Recommended Action
On	On/Closed/Activated	Your input device will not turn off.	Device is shorted or damaged.	Verify device operation. Replace device.
		Your program operates as though it is off.	Input is forced off in program.	Check the FORCED I/O or FORCE LED on processor and remove forces.
			Input circuit is damaged.	Try other input circuit. Replace module.
	Off/Open/Deactivated	Your program operates as though it is on and/or the input circuit will not turn off.	Input device Off-state leakage current exceeds input circuit specification.	Check device and input circuit specifications. Use load resistor to bleed-off current.
			Input device is shorted or damaged.	Verify device operation. Replace device.
			Input circuit is miswired or damaged.	Verify proper wiring. Try other input circuit. Replace module.
Off	On/Closed/Activated	Your program operates as though it is off and/or the input circuit will not turn on.	Input circuit is incompatible.	Check specification and sink/source compatibility (if DC input).
			Low voltage across the input.	Check the voltage across input circuit and check source voltage.
			Incorrect wiring or an open circuit.	Check wiring and COMMon connections.
			Input signal turn on time too fast for input circuit.	Check timing specifications.
			Input circuit is damaged.	Verify proper wiring. Try other input circuit. Replace module.
	Off/Open/Deactivated	Your input device will not turn on.	Input device is opened or damaged.	Verify operation. Replace device.
			Your program operates as though it is on.	Input is forced on in program.
		Input circuit is damaged.		Verify proper wiring. Try other input circuit. Replace module.

Troubleshooting Your Output Modules

The following will assist you in troubleshooting your output modules.

Output Circuit Operation

An output circuit controls the output signal in the following manner:

1. The processor determines the output status.
2. Logic circuits maintain the output status.
3. An output LED indicates the status of the output signal.
4. Optical isolation separates logic and backplane circuits from field signals.
5. The output driver turns the corresponding output on or off.

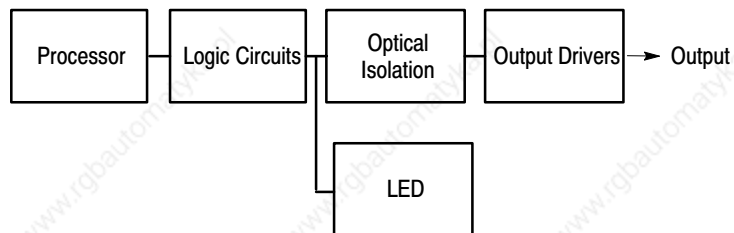

Corrective Action

If your Output Circuit LED is	And Your Output Device is	And	Probable Cause	Recommended Action
On	On/Energized	Your program indicates that the output circuit is off or the output circuit will not turn off.	Programming problem.	Check for duplicate outputs and addresses using the search function. If using subroutines, outputs are left in their last state when not executing subroutines. Use the force function to force output off. If this does not force the output off, output circuit is damaged. If the output does force off, then check again for logic/programming problem.
			Output is forced on in program.	Check processor FORCED I/O or FORCE LED and remove forces.
			Output circuit is damaged.	Use the force function to force the output off. If this forces the output off, then there is a logic/programming problem. If this does not force the output off, the output circuit is damaged. Try other output circuit. Replace module.
	Off/De-energized	Your output device will not turn on and the program indicates that it is on.	Low or no voltage across the load.	Measure the source voltage and check specifications.
			Incorrect wiring or open circuit.	Check wiring and COMmon connections.
			Output device is incompatible.	Check specifications and sink/source compatibility (if DC output).
			Output circuit is damaged.	Check wiring. Try other output circuit. Replace module.
Off	On/Energized	Your output device will not turn off and the program indicates that it is off.	Output device is incompatible.	Check specifications.
			Output circuit Off-state leakage current may exceed output device specification.	Check specifications. Use load resistor to bleed off leakage current. See output specifications.
			Incorrect wiring.	Check wiring. Disconnect from SLC and verify device operation.
			Output device is shorted or damaged.	Verify device operation. Replace device.
			Output circuit is damaged.	Check wiring. Try other output circuit. Replace module.
	Off/De-energized	Your program indicates that the output circuit is on or the output circuit will not turn on.	Programming problem.	Check for duplicate outputs and addresses using search function. If using subroutines, outputs are left in their last state when not executing subroutines. Use the force function to force output on. If this does not force the output on, output circuit is damaged. If the output does force on, then check again for logic/programming problem.
				Output is forced off in program.
			Output circuit is damaged.	Use the force function to force the output on. If this forces the output on, then there is a logic/programming problem. If this does not force the output on, the output circuit is damaged. Try other output circuit. Replace module.

Replacement Parts

This chapter provides a list of replacement parts and a list of replacement terminal blocks for your SLC 500 controller.

Replacement Parts

This table provides a list of replacement parts and their catalog numbers.

Description	Catalog Number
Pre-wired Interface Cable — Available in 1.0m, 2.5m, and 5.0m lengths.	1492-CABLE [Ⓜ] H
Replacement Fuses — Five fuses per package. Orders must be for five fuses or multiples of five.	
Replacement fuse for Fixed I/O AC units, MDL 1.25 Ampere	1746-F4
Replacement fuse for Fixed I/O DC units, MDL 1.6 Ampere	1746-F5
Modular Card Slot Fillers — Two fillers per package. Orders must be for two fillers or multiples of two.	1746-N2
Connector — Mating Connector for 32 Point user-made cable	1746-N3
Kit consisting of four replacement terminal covers and labels for 4, 8, 16 I/O modules	1746-R9
Replacement Cover for Specialty I/O Two covers per package. Orders must be for two covers or multiples of two.	1746-R13
Replacement Retainer Clips for Modules Four clips per package. Orders must be for four clips or multiples of four.	1746-R15
Lithium Battery Assembly This is an optional part used for the SLC 500 Fixed and Modular Hardware Style processors and the Hand-Held Terminal. Refer to product documentation for proper storage and handling instructions. For disposal information, consult your nearest Allen-Bradley Sales Office.	1747-BA
Processor to Peripheral Programming/Communication Cable	1747-C10
Processor to Isolated Link Coupler Cable	1747-C11
Specialty Module to Isolated Link Coupler Cable	1747-C13
EEPROM with 1K User Instructions	1747-M1
UVPR0M with 1K User Instructions	1747-M3
Adapter Sockets — Orders must be for five sockets or multiples of five.	1747-M5
Replacement Parts Kit for 20 I/O Fixed Hardware Style Processor Two Output Terminal Covers Two Input Terminal Covers Two Prom/Battery Covers One HHT/Comm Connector Cover	1747-R5
Replacement Parts Kit for 30 and 40 I/O Fixed Hardware Style Processors Two Output Terminal Covers Two Input Terminal Covers Two Prom/Battery Covers One HHT/Comm Connector Cover	1747-R7
Replacement Terminal Covers for 4, 8, & 16 I/O Modules This kit contains four blank covers and appropriate labels for replacement of any required I/O module cover.	1747-R9
HHT Keypad Replacement Overlay for English Memory Pak Firmware Releases 1.02, 1.07 and 1.10	1747-R20
HHT Keypad Replacement Overlay for French Memory Pak Firmware Releases 1.10	1747-R20F
HHT Keypad Replacement Overlay for German Memory Pak Firmware Releases 1.10	1747-R20G
HHT Keypad Replacement Overlay for Italian Memory Pak Firmware Releases 1.10	1747-R20I
HHT Keypad Replacement Overlay for English Memory Pak Firmware Releases 2.00 and Later	1747-R21
HHT Keypad Replacement Overlay for French Memory Pak Firmware Releases 2.00 and Later	1747-R21F

[Ⓜ] Insert the cable length code into the catalog number. Cable length codes are as follows: 10=1.0m, 25=2.5m, and 50=5.0m. For example, 1492-CABLE25H is a 2.5m cable.

Replacement Terminal Blocks

This table provides a list of replacement terminal blocks and their catalog numbers.

Description	Catalog Number
Replacement Terminal Block (Red) — Used with AC I/O modules, Catalog Numbers 1746-IA16, OA16, IM16	1746-RT25R
Replacement Terminal Block (Blue) — Used with DC I/O modules, Catalog Numbers 1746-IB16, IV16, OB16, OV16, IN16, IG16, OG16	1746-RT25B
Replacement Terminal Block (Orange) — Used with relay output modules, Catalog Numbers 1746-OW16, OX8	1746-RT25C
Replacement Terminal Block (Green) — Used with Specialty I/O modules, Catalog Numbers 1746-HSCE, IO12	1746-RT25G
Replacement Terminal Block — 2 position terminal block used with analog output modules, Catalog Numbers 1746-NO4I, NO4V	1746-RT26
Replacement Terminal Block — 8 position terminal block used with analog output modules, Catalog Numbers 1746-NO4I, NO4V	1746-RT27
Replacement Terminal Block — Used with analog input modules, Catalog Numbers 1746-NI4, NIO4I, NIO4V	1746-RT28
Replacement Terminal Block — Used with RIO Communication Modules, Catalog Numbers 1747-SN, DSN, DCM	1746-RT29
Replacement Terminal Block — Used with DH-485 Link Coupler, Catalog Number 1747-AIC	1746-RT30

Setting Up the DH-485 Network

The information in this appendix will help you plan, install, and operate the SLC 500 in a DH-485 network. This chapter also contains information that describes the DH-485 network functions, network architecture, and performance characteristics. It also covers:

- DH-485 network description
- DH-485 network protocol
- DH-485 token rotation
- DH-485 network initialization
- devices that use the DH-485 network
- 1747-AIC isolated link coupler for DH-485
- example system configuration
- important planning considerations
- DH-485 network installation

DH-485 Network Description

We have designed the DH-485 network to pass information between devices on the plant floor. The network monitors process parameters, device parameters, device status, process status and application programs to support data acquisition, data monitoring, program upload/download and supervisory control.

The DH-485 network offers:

- interconnection of 32 devices
- multi-master capability
- token passing access control
- the ability to add or remove nodes without disrupting the network
- maximum network length of 1219 m (4000 ft)

DH-485 Network Protocol

The following section describes the protocol used to control message transfers on the DH-485 network. The protocol supports two classes of devices: initiators and responders. All initiators on the network get a chance to initiate message transfers. To determine which initiator has the right to transmit, a token passing algorithm is used.

DH-485 Token Rotation

A node holding the token can send any valid packet onto the network. Each node is allowed only one transmission (plus two retries) each time it receives the token. After a node sends one message packet, it attempts to give the token to its successor by sending a “token pass” packet to its successor.

If no network activity occurs, the initiator sends the token pass packet again. After two retries (a total of three tries) the initiator will attempt to find a new successor.

Important: The maximum address that the initiator will search for before wrapping to zero is the value in the configurable parameter “maximum node address.” The default value for this parameter is 31 for all initiators and responders.

The allowable range of the node address of an initiator is 0 to 31. The allowable address range for all responders is 1 to 31. There must be at least one initiator on the network.

DH-485 Network Initialization

Network initialization begins when a period of inactivity exceeding the time of a link dead timeout is detected by an initiator on the network. When the time for a link dead timeout is exceeded, usually the initiator with the lowest address claims the token. When an initiator has the token it will begin to build the network. The network requires at least one initiator to initialize it.

Building a network begins when the initiator that claimed the token tries to pass the token to the successor node. If the attempt to pass the token fails, or if the initiator has no established successor (for example, when it powers up), it begins a linear search for a successor starting with the node above it in the addressing.

When the initiator finds another active initiator, it passes the token to that node, which repeats the process until the token is passed all the way around the network to the first node. At this point, the network is in a state of normal operation.

Devices that Use the DH-485 Network

Presently, the following SLC 500 devices support the DH-485 network:

- SLC 500 Fixed I/O Controller (responder)
- SLC 5/01 Modular I/O Controller (responder)
- SLC 5/02 Modular I/O Controller (initiator/responder)
- SLC 5/03 Modular I/O Controller (initiator/responder)
- Personal computer running SLC 500 Advanced Programming Software (initiator)
- Hand-Held Terminal (initiator)
- DTAM (initiator/responder)

Other devices that use the DH-485 network include those in the table below.

Catalog Number	Description	Installation Requirement	Function	Publication
1746-BAS	BASIC Module	SLC Chassis	Provides an interface for SLC 500 devices to foreign devices. Program in BASIC to interface the 3 channels (2 RS-232 and 1 DH485) to printers, modems, or the DH-485 network for data collection.	1746-ND005 1746-NM002 1746-NM001
1747-KE	DH-485/DF1 Interface Module	SLC Chassis	Provides a non-isolated DH-485 interface for SLC 500 devices to host computers over RS-232 using full- or half-duplex DF1 protocol. Enables remote programming with APS to an SLC 500 processor or the DH-485 network through modems. Ideal for low cost RTU/SCADA applications.	1747-NU001
1770-KF3	DH-485/DF1 Interface Module	Standalone ("desktop")	Provides an isolated DH-485 interface for SLC 500 devices to host computers over RS-232 using full- or half-duplex DF1 protocol. Enables remote programming with APS to an SLC 500 processor or the DH-485 network through modems.	1770-6.5.18
1784-KR	PC DH-485 Interface Module	IBM XT/AT Computer Bus	Provides an isolated DH-485 port on the back of the computer. When used with APS software, it improves communication speed and eliminates use of the Personal Interface Converter (1747-PIC). The Standard Driver allows you to write "C" programs for data acquisition applications.	1784-2.23 6001-6.5.5
1785-KA5	DH+™ /DH485 Gateway	(1771) PLC® Chassis	Provides communication between stations on the PLC-5 (DH+) and SLC 500 (DH-485) networks. Enables communication and data transfer from PLC to SLC 500 on DH-485 network. Also enables APS programming or data acquisition across DH+ to DH-485.	1785-6.5.5 1785-1.21
2760-RB	Flexible Interface Module	(1771) PLC Chassis	Provides an interface for SLC 500 (using protocol cartridge 2760-SFC3) to other A-B PLCs and devices. Three configurable channels are available to interface with Bar Code, Vision, RF, Dataliners, and PLC systems.	2760-ND001

1747-AIC Isolated Link Coupler for DH-485

The isolated link coupler (1747-AIC) is used to connect SLC 500 family devices to the DH-485 network (as shown on page A-5). The coupler provides a 6-position removable terminal block for connection to the DH-485 communication cable.

Network connections for the SLC 500 processor are provided by the Catalog Number 1747-C11, 304.8 mm (12 in.) cable supplied with the link coupler. Network connections for peripheral devices, such as the Personal Interface Converter (1747-PIC), Data Table Access Module (1747-DTAM-E), or Hand-Held Terminal (1747-PT1) are provided by the standard Catalog Number 1747-C10 1.8 m (6 ft) cable supplied with each of those devices.

To protect connected devices, the coupler provides 1500 VDC isolation between the communications cable and the attached SLC 500 controller and peripheral devices (PIC, DTAM, or HHT).

The isolated link coupler can also be used to provide connectivity between a peripheral device (APS and PIC, HHT, or DTAM) for distances greater than 1.8 m (6 ft) up to a maximum of 1219 m (4000 ft). Below is an example of a “remote” connection between a computer running APS and an SLC 500 processor.

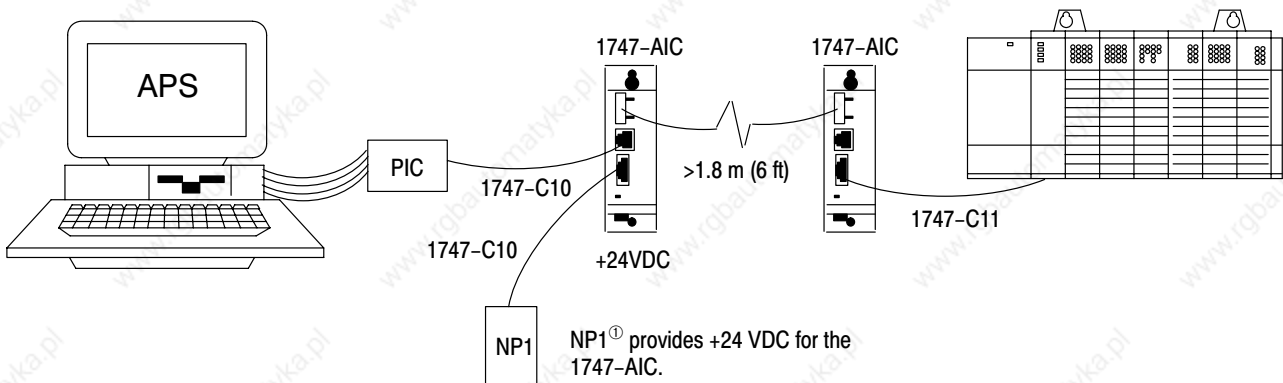

^① You can also use an NP2 desktop model.

Example System Configuration Below is an example of a DH-485 network.

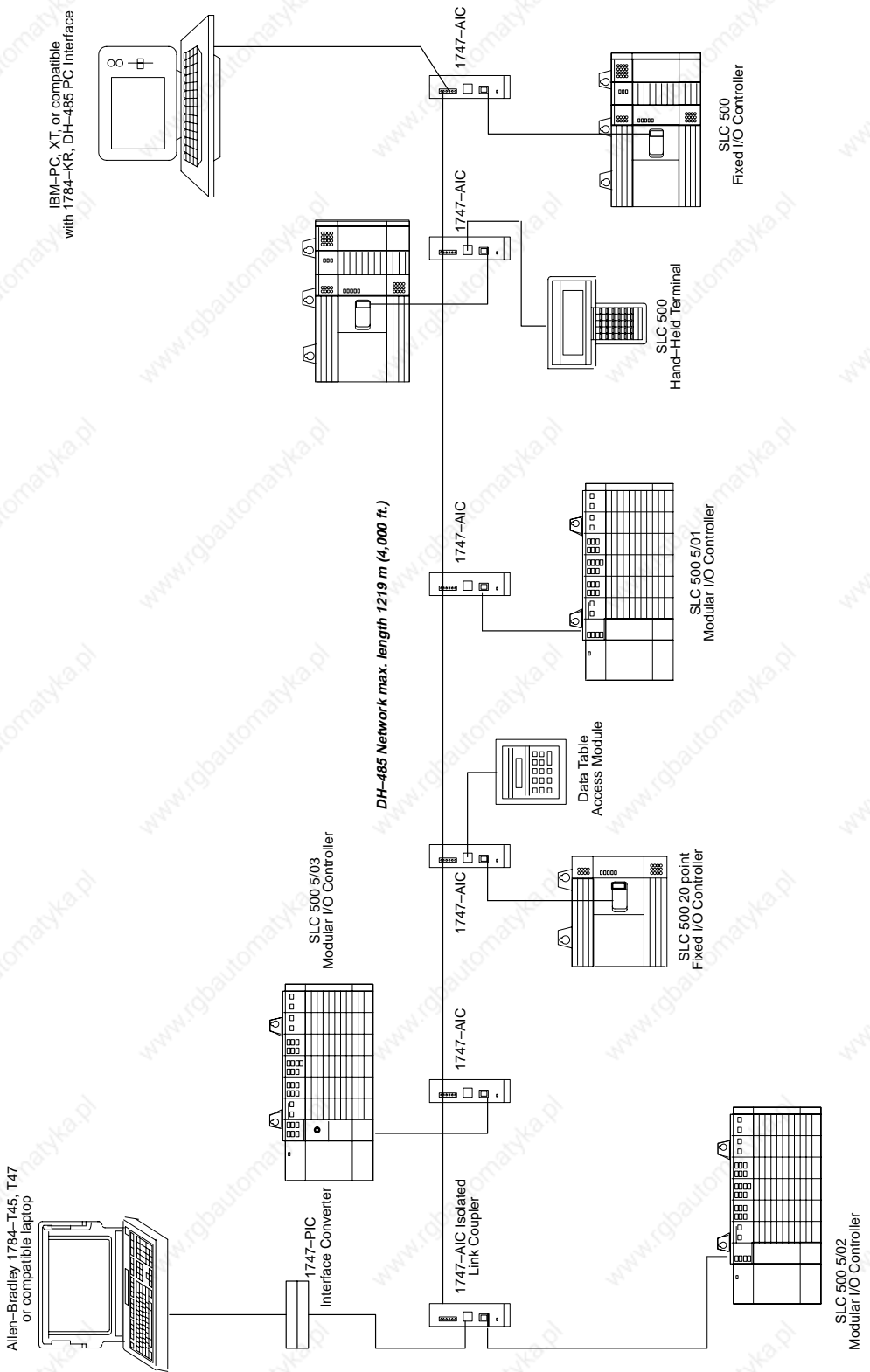

Important Planning Considerations

Carefully plan your network configuration before installing any hardware. Listed below are some of the factors that can affect system performance:

- amount of electrical noise, temperature, and humidity in the network environment
- number of devices on the network
- connection and grounding quality in installation
- amount of communication traffic on the network
- type of process being controlled
- network configuration

The major hardware and software issues you need to resolve before installing a network are discussed in the following sections.

Hardware Considerations

You need to decide the length of the communication cable, where you route it, and how to protect it from the environment where it will be installed.

When the communication cable is installed, you need to know how many devices are to be connected during installation and how many devices will be added in the future. The following sections will help you understand and plan the network.

Number of Devices and Length of Communication Cable

You must install a link coupler (1747-AIC) for each node on the network. If you plan to add nodes later, provide additional link couplers during the initial installation to avoid recabling after the network is in operation.

The maximum length of the communication cable is 1219 m (4000 ft). This is the total cable distance from the first node to the last node on the network.

Planning Cable Routes

Follow these guidelines to help protect the communication cable from electrical interference:

- Keep the communication cable at least five feet from any electric motors, transformers, rectifiers, generators, arc welders, induction furnaces, or sources of microwave radiation.
- If you must run the cable across power feed lines, run the cable at right angles to the lines.
- If you do not run the cable through a contiguous metallic wireway or conduit, keep the communication cable at least 0.15 m (6 in) from ac power lines of less than 20 A, 0.30 m (1 ft) from lines greater than 20 A, but only up to 100 kVA, and 0.60 m (2 ft) from lines of 100 kVA or more.
- If you run the cable through a contiguous metallic wireway or conduit, keep the communication cable at least 0.08 m (3 in) from ac power lines of less than 20 A, 0.15 m (6 in) from lines greater than 20 A, but only up to 100 kVA, and 0.30 m (1 ft) from lines of 100 kVA or more.

Running the communication cable through conduit provides extra protection from physical damage and electrical interference. If you route the cable through conduit, follow these additional recommendations:

- Use ferromagnetic conduit near critical sources of electrical interference. You can use aluminum conduit in non-critical areas.
- Use plastic connectors to couple between aluminum and ferromagnetic conduit. Make an electrical connection around the plastic connector (use pipe clamps and the heavy gauge wire or wire braid) to hold both sections at the same potential.
- Ground the entire length of conduit by attaching it to the building earth ground.
- Do not let the conduit touch the plug on the cable.
- Arrange the cables loosely within the conduit. The conduit should contain only serial communication cables.
- Install the conduit so that it meets all applicable codes and environmental specifications.

For more information on planning cable routes, see *Industrial Automation Wiring and Grounding Guidelines*, publication number 1770-4.1.

Software Considerations

Software considerations include the configuration of the network and the parameters that can be set to the specific requirements of the network. The following are major configuration factors that have a significant effect on network performance:

- number of nodes on the network
- addresses of those nodes
- baud rate
- maximum node address selection
- *5/03 only*: token hold factor

The following sections explain network considerations and describe ways to select parameters for optimum network performance (speed).

Number of Nodes

The number of nodes on the network directly affects the data transfer time between nodes. Unnecessary nodes (such as a second programming terminal that is not being used) slow the data transfer rate. The maximum number of nodes on the network is 32.

Setting Node Addresses

The best network performance occurs when node addresses start at 0 and are assigned in sequential order. SLC 500 processors default to node address 1. The node address is stored in the processor status file (S:15L). Processors cannot be node 0. Also, initiators such as personal computers should be assigned the lowest numbered addresses to minimize the time required to initialize the network.

If some nodes are connected on a temporary basis, do not assign addresses to them. Simply create nodes as needed and delete them when they are no longer required.

Setting Processor Baud Rate

The best network performance occurs at the highest baud rate, which is 19200. All devices must be at the same baud rate. The default baud rate for SLC 500 devices is 19200. The baud rate is stored in the processor status file (S:15H).

Maximum Node Address Setting

The maximum node address parameter should be set as low as possible. This minimizes the amount of time used in soliciting successors when initializing the network. If all nodes are addressed in sequence from 0, and the maximum node address is equal to the address of the highest addressed node, the token rotation will improve by the amount of time required to transmit a solicit successor packet plus the slot timeout value.

Note that this does not allow any node to be added to the network without affecting the response time. On the other hand, since the time required to hold an open station address is greater than the time required to pass a token, it can be useful to leave a temporary device (such as a personal computer) connected if there is only one such device. (A solicit successor packet requires the same transmission time as the token pass, but there is an added slot timeout period.)

See the *Hand-Held Terminal User Manual*, Catalog Number 1747-NP002, or the *Advanced Programming Software User Manual*, Catalog Number 1747-NM002, for the procedures to set node addresses, processor baud rate, and maximum node addresses.

Important: The SLC 500 Series A (only) processors set the maximum node address to 31 when power is cycled increasing initialization and response time of the network.

DH-485 Network Installation

To install a DH-485 network, you will need tools to strip the shielded cable and to attach the cable and terminators to the isolated link coupler. Install the DH-485 network using the following tools (or equivalent):

Description	Part Number	Manufacturer
Shielded Twisted Pair Cable	#9842	Belden
Stripping Tool	45-164	Ideal Industries
1/8" Slotted Screwdriver	NA	NA

DH-485 Communication Cable and Isolated Link Coupler

The link coupler provides a connection for each node. The isolated link coupler electrically isolates the DH-485 communication interface from the processor and peripheral connections. Electrical-optical isolation is provided to 1500 VDC.

The suggested DH-485 communication cable is Belden #9842 cable. The cable is jacketed and shielded with two twisted wire pairs and a drain wire.

One pair provides a balanced signal line, and one wire of the other pair is used for a common reference line between all nodes on the network. The shield reduces the effect of electrostatic noise from the industrial environment on the network communication.

Installing the DH-485 Communication Cable

The communication cable consists of a number of cable segments daisy-chained together. The total length of the cable segments cannot exceed 1219 m (4000 ft).

When cutting cable segments, make them long enough to route them from one link coupler to the next with sufficient slack to prevent strain on the connector. Allow enough extra cable to prevent chafing and kinking in the cable.

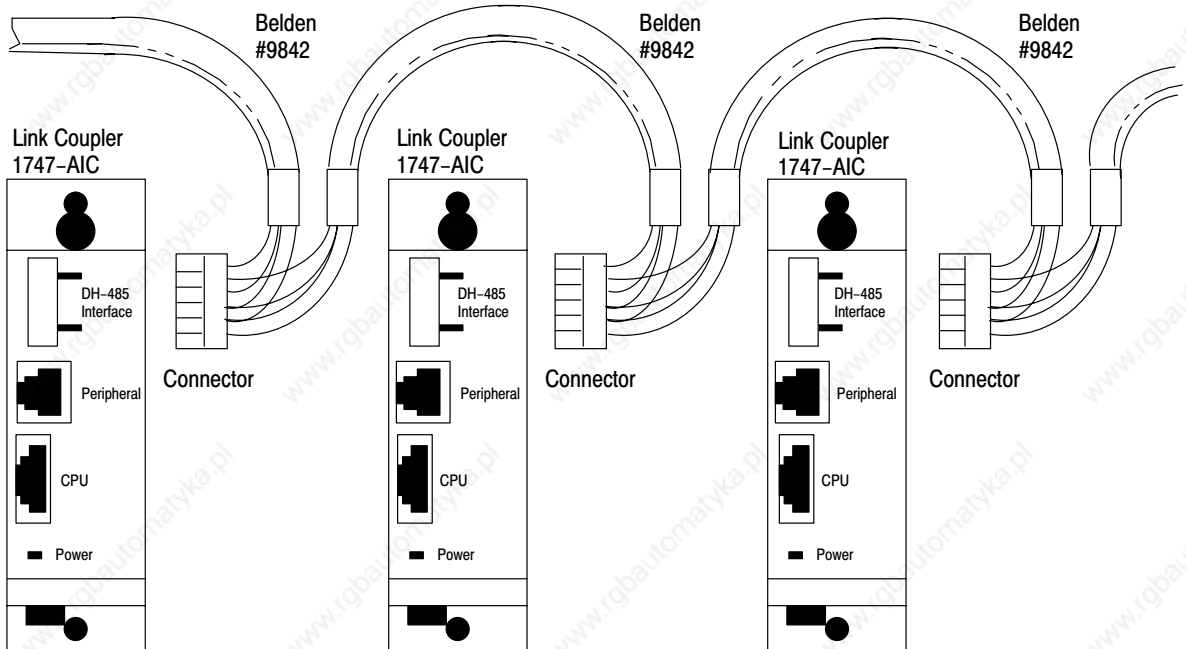

Important: We only recommend a network that is daisy-chained. For example, we do *not* recommend the following:

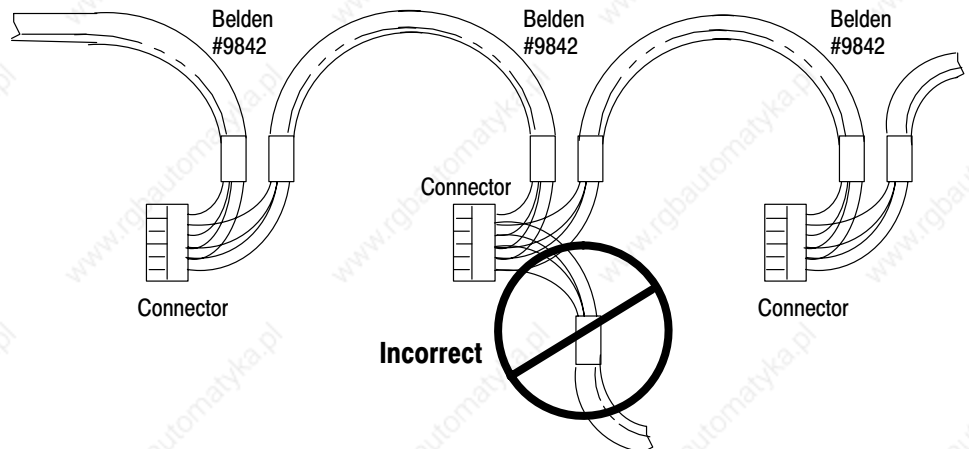

Connecting the Communication Cable to the Isolated Link Coupler

Attach the terminal block of the link coupler to the Belden #9842 cable as shown below. Additional terminal blocks are available for replacement, see chapter 9.

Single Cable Connection

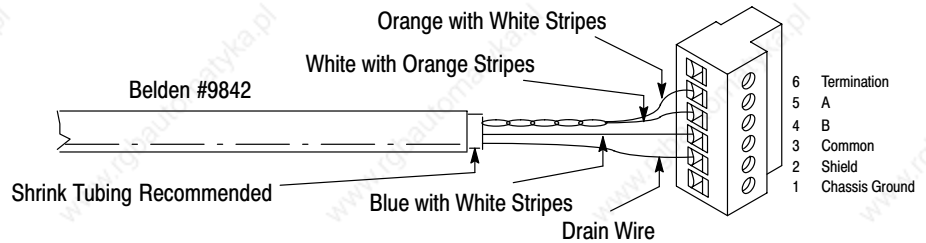

Multiple Cable Connection

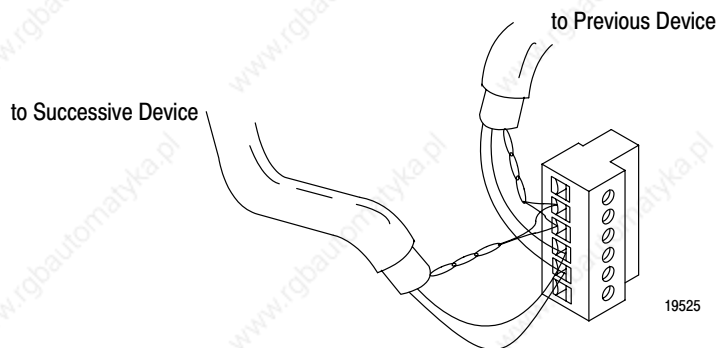

Appendix A
Setting Up the DH-485 Network

The table below shows wire/terminal connections for DH-485 connectors for *old* Belden #9842.

For this Wire/Pair	Connect this Wire	To this Terminal
Shield/Drain	Non-jacketed	Terminal 2 - Shield
Black/White	Black	Cut back - no connection ^①
	White	Terminal 3 - (Common)
Black/Red	Black	Terminal 4 - (Data B)
	Red	Terminal 5 - (Data A)

^① To prevent confusion when installing the communication cable, cut back the black wire immediately after the the insulation jacket is removed. This wire is not used by DH-485.

The table below shows wire/terminal connections for DH-485 connectors for *new* Belden #9842.

For this Wire/Pair	Connect this Wire	To this Terminal
Shield/Drain	Non-jacketed	Terminal 2 - Shield
Blue/White	White with Blue Stripe	Cut back - no connection ^①
	Blue with White Stripe	Terminal 3 - (Common)
White/Orange	White with Orange Stripe	Terminal 4 - (Data B)
	Orange with White Stripe	Terminal 5 - (Data A)

^① To prevent confusion when installing the communication cable, cut back the white with blue stripe wire immediately after the the insulation jacket is removed. This wire is not used by DH-485.

Important: In Series A 1747-AIC, terminal 5 was called DATA B and terminal 4 was called DATA A. In this case, use terminal numbers only and ignore signal names DATA B and DATA A. The internal circuitry of the Series A is the same as Series B.

Grounding and Terminating the DH-485 Network

One (only one) of the link couplers at the end of the link must have Terminals 1 and 2 of the network connector jumpered together. This provides an earth ground connection for the shield of the communication cable.

Link couplers at both ends of the network must have Terminals 5 and 6 of the link connectors jumpered together. This connects the termination impedance (of 120Ω) that is built into each link coupler as required by the DH-485 specification. See the figure below for the proper jumpering.

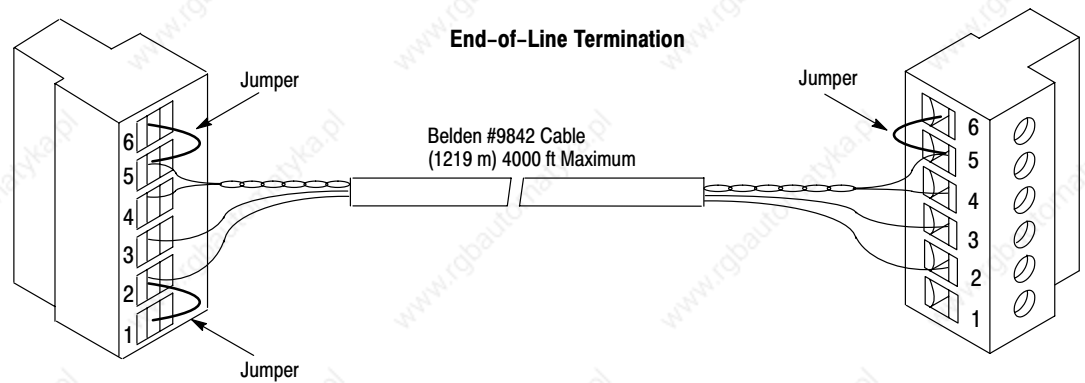

Powering the Link Coupler

In normal operation with the programmable controller connected to the link coupler, the processor powers both the link coupler and peripheral device (DTAM, PIC, HHT) — if connected — through the C11 cable.

If you do not connect the processor to the link coupler, then use a 24 VDC power supply to power the link coupler and peripheral device. The 1747-AIC requires 85mA at 24 VDC. With a peripheral device connected, the total current required is 190mA at 24 VDC.

If both the processor and external power are connected to the link coupler, only the external source is used.

Important: Always connect the CHS GND (chassis ground) terminal to the nearest earth ground. This connection must be made whether or not an external 24 VDC supply is used.

Below are three options for externally powering the 1747-AIC:

- If the link coupler is to be installed in an office environment, you can use the wall mount power supply (1747-NP1) or global desktop power supply (1747-NP2). The link coupler would be powered through either the 1747-C10 cable or by hardwiring from the supply to the screw terminals on the link coupler.
- If you use the AC chassis power supplies (1746-P1 or 1746-P2), you can use the 24 VDC user power supply (200mA maximum) built into the power supply. The link coupler would be powered through a hard-wired connection from the screw terminals on the power supply to the screw terminals on bottom of the link coupler.
- You can use an external DC power supply with the following specifications:
 - operating voltage: 24 VDC \pm 25%
 - output current: 190mA
 - rated NEC

The link coupler would be powered through a hard-wired connection from the external supply to the screw terminals on the bottom of the link coupler.



ATTENTION: If you use an external power supply, it must be 24 VDC. Permanent damage will result if miswired with the wrong power source.

The figure below shows the external wiring connections and specifications of the link coupler.

Left Side

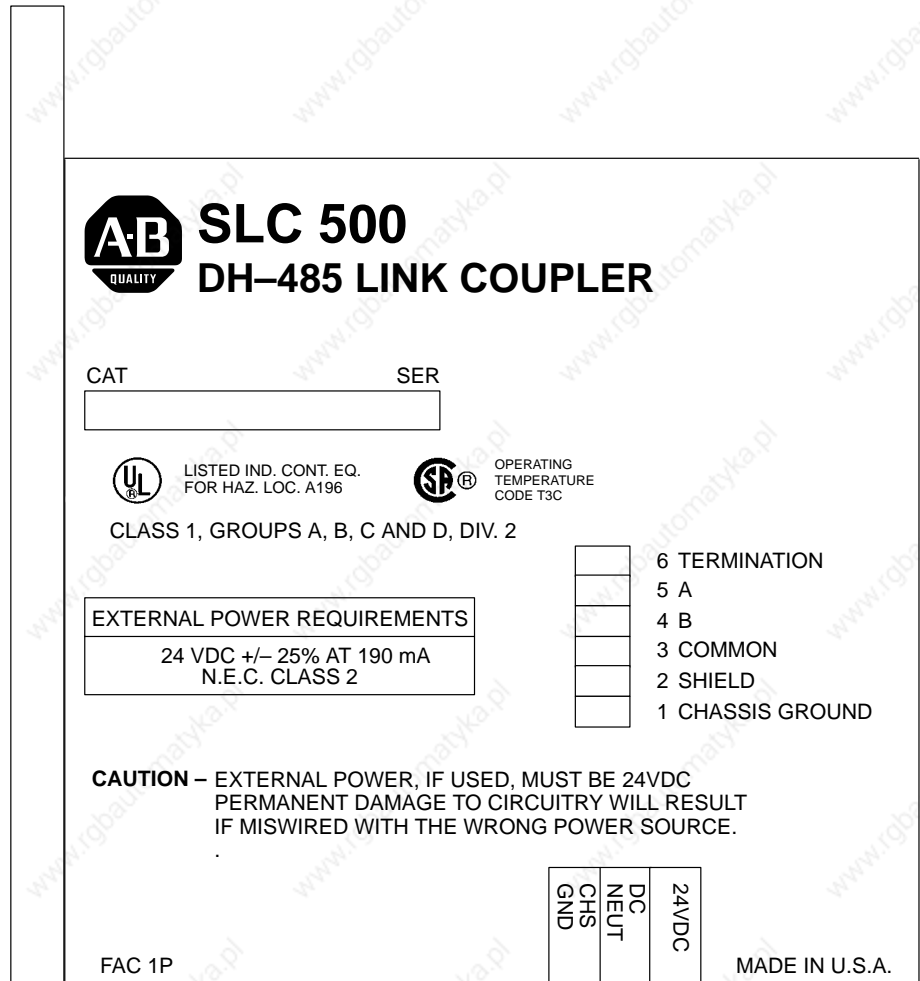

Bottom

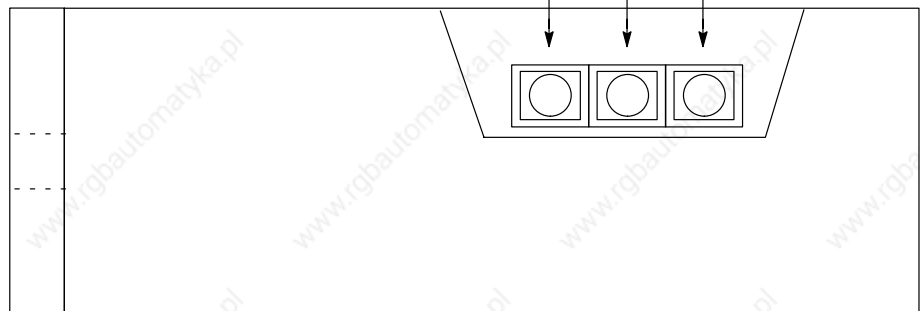

You can connect an unpowered link coupler to the DH-485 network without disrupting network activity. In addition, if an SLC 500 controller powers a link coupler that is connected to the DH-485 network, network activity will not be disrupted should the SLC 500 controller be removed from the link coupler.

Installing and Attaching the Link Couplers

1. Take care when installing the link coupler in an enclosure so that the cable connecting the SLC 500 controller to the link coupler does not hit the enclosure door.
2. Carefully plug the terminal block into the DH-485 port on the link coupler you are putting on the network. Allow enough cable slack to prevent stress on the plug.
3. Provide strain relief for the Belden #9842 cable after it is wired to the terminal block. This guards against breakage of the Belden cable wires.

The 1771-Remote I/O Network

This appendix provides a brief introduction about the 1771-Remote I/O Network. For information on the 1771-Remote I/O Network, see the *Direct Communication Module User Manual*, Catalog Number 1747-NM007 and the *Remote I/O Scanner User Manual*, Catalog Number 1747-NM005.

1771-Remote I/O Network

The Allen-Bradley 1771-Remote I/O Network enables chassis of I/O, operator interface terminals, push-button panels, blocks of I/O, message displays, drives and much more to be great distances from the host PLC processor. The SLC 500 controller (fixed, 5/01, 5/02, or 5/03) can interface to this network through the 1747-DCM module for distributed processing. The DCM allows the SLC 500 to look like another device on the network.

Below is an example of the 1771-Remote I/O Network.

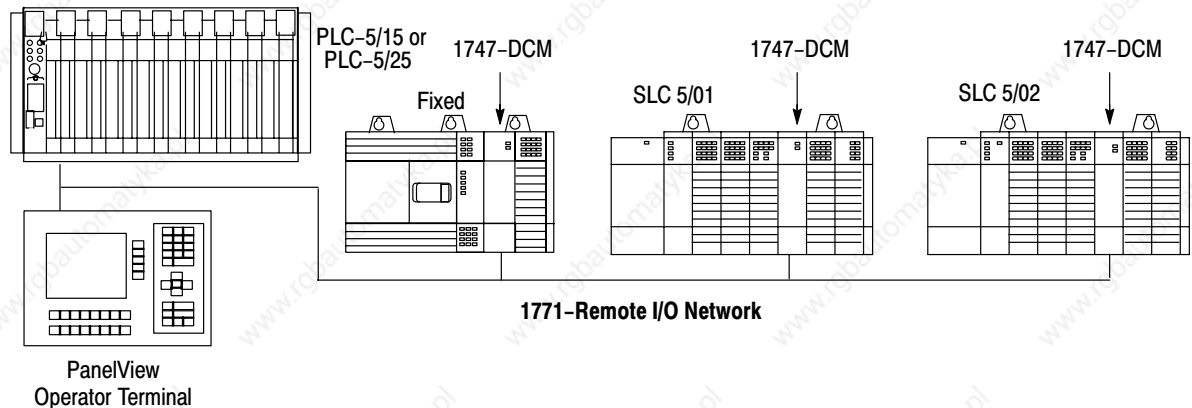

With the SLC 5/02 or 5/03 processor, a 1747-SN Remote I/O Scanner can be used as the host of the remote I/O network. With a SLC 5/02 or 5/03 and SN, a PLC is not required on the network.

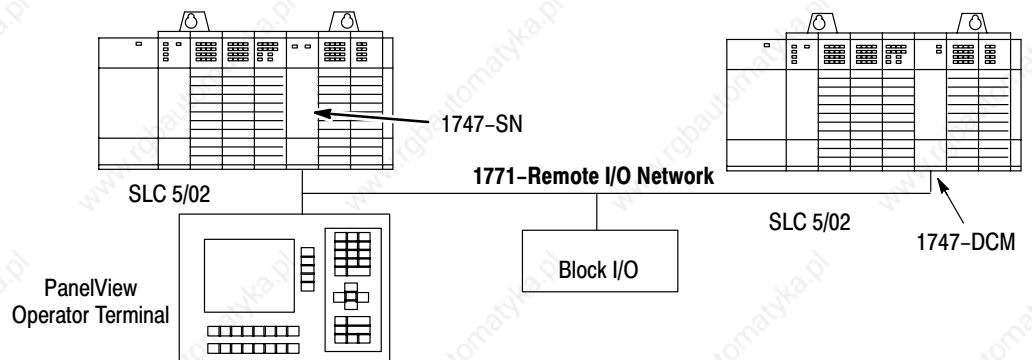

RS-232 Communication Interface

This appendix provides an overview of the RS-232 communication interface. This appendix also provides information on the following:

- RS-232 and SCADA applications
- RS-232 communication interface overview
- SLC 500 devices that support RS-232 communication
- wiring connectors for RS-232 communication

RS-232 and SCADA Applications

RS-232 is a communication interface included under SCADA (Supervisory Control and Data Acquisition) applications. SCADA is a term that refers to control applications that require communication over long distances. For more information about the use of Allen-Bradley equipment in SCADA applications, refer to the *Allen-Bradley SCADA Applications Guide*, Publication Number ICCG-11.6.

RS-232 Communication Interface Overview

RS-232 is an Electronics Industries Association (EIA) standard that specifies the electrical, mechanical, and functional characteristics for serial binary communication. It provides you with a variety of system configuration possibilities that differ from those offered by DH-485.

One of the biggest benefits of RS-232 communication is that it lets you integrate telephone and radio modems into your control system. The distance over which you are able to communicate with certain system devices is virtually limitless.

The SLC and PLC products detailed in this appendix that communicate over the RS-232 communication interface also use the DF1 serial communication protocol. DF1 protocol delimits messages, controls message flow, detects and signals errors, and retries after errors are detected.

SLC 500 Devices that Support RS-232 Communication

The SLC 500 product line has three other modules, aside from the SLC 5/03 processor, that support the RS-232 communication interface. They are the DH-485 Communication Interface (1770-KF3), the BASIC module (1746-BAS), and the DH-485/RS-232C Interface (1747-KE). All three of these modules can be used with SLC 500 Fixed Controller.

1770-KF3 Module

The 1770-KF3 module links host computers with the Allen-Bradley DH-485 Data Highway. The host computer communicates with the 1770-KF3 over an RS232 link using DF1 protocol. Through the 1770-KF3, the host computer can communicate with the nodes on the DH-485 network.

For more information on the 1770-KF3 module, see the *DH-485 Communication Interface User Manual*, Catalog Number 1770-6.5.18.

1747-KE Module

The 1747-KE is a communication interface module that acts as a bridge between DH-485 networks and devices requiring DF1 protocol. You can configure the DF1 port on the 1747-KE for RS-232/423, RS-422, or RS-485 devices. Residing in an SLC 500 chassis, the 1747-KE is ideally used as an interface module, linking remote DH-485 networks via a modem to a central host.

For more information on the 1747-KE module, see the *DH-485/RS-232 Interface Module User Manual*, Catalog Number 1747-NU001.

1746-BAS Module

The 1746-BAS module, which is programmed using the BASIC language, has two configurable serial ports for interfacing to computers, modems, printers, and other RS-232 compatible devices. You can also use it for off-loading complex math routines from an SLC 500 processor; this conserves valuable ladder logic memory.

For more information on the 1746-BAS module, see the *SLC 500 BASIC Module Design and Integration Manual*, Catalog Number 1746-ND005.

Wiring Connectors for RS-232 Communication

To connect Allen-Bradley devices with other devices over RS-232, you must wire the cable connectors so that communication can occur through the cabling, which provide the interface between devices.

Types of RS-232 Connectors

The figure below shows male connectors, and their pinout locations, for Allen-Bradley modules.

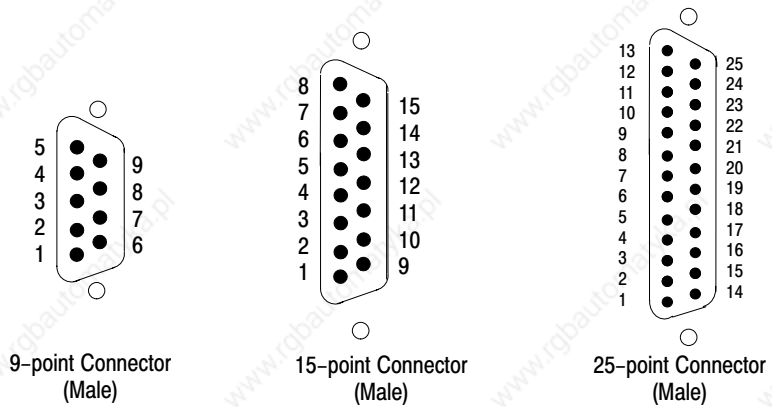

DTE Pinout

Channel 0, which the 5/03 processor has, is configured as DTE. The pinouts are the same as the 9-pin AT port.

DTE 9 pinout	Signal is	Equivalent DTE 15 pinout	Equivalent DTE 25 pinout
1 -DCD Data Carrier Detect	Input	8	8
2 -RXD Received Data	Input	3	3
3 -TXD Transmitted Data	Output	2	2
4 -DTR Data Terminal Ready	Output	11	20
5 -COM Common Return (Signal Ground)	Shared	7	7
6 -DSR Data Set Ready	Input	6	6
7 -RTS Request to Send	Output	4	4
8 -CTS Clear to Send	Input	5	5
9 -NC No Connection	Input		22 RI Ring Indicator

DCE Pinout

Devices such as a modem are DCE. The pinouts on these terminals are wired to interface with DTE.

DCE 9 pinout	Signal is	Equivalent DCE 25 pinout
1 -DCD Data Carrier Detect	Output	8
2 -RXD Received Data	Output	3
3 -TXD Transmitted Data	Input	2
4 -DTR Data Terminal Ready	Input	20
5 -COM Common Return (Signal Ground)	Shared	7
6 -DSR Data Set Ready	Output	6
7 -RTS Request to Send	Input	4
8 -CTS Clear to Send	Output	5
9 -RI Ring Indicator	Output	22

Important: DCE signal names are viewed from a DTE perspective. For example, TXD is a DTE output and also a DCE input.

Pin Assignments for Wiring Connectors

Use the following pin assignments to wire the connectors of Allen–Bradley control devices with modems and peripheral devices that support RS–232 communication. See the table below to find the wiring diagram that you need.

To Connect this Device	To this Device	Remarks	See this Page
IBM AT	Modem	Hardware Handshaking Enabled	C-6
	Peripheral DTE	Hardware Handshaking Disabled	C-6
1747-KE	Modem	Hardware Handshaking Enabled	C-7
	Peripheral DTE	Hardware Handshaking Disabled	C-7
1746-BAS	Modem	Hardware Handshaking Enabled	C-8
	Peripheral DTE	Hardware Handshaking Disabled	C-8
1770-KF3	Modem	Hardware Handshaking Enabled	C-8
2760-RB	Modem	Hardware Handshaking Enabled	C-9
	Peripheral DTE	Hardware Handshaking Disabled	C-9
1771-KGM (PLC-2)	Modem	Hardware Handshaking Enabled	C-10
	Peripheral DTE	Hardware Handshaking Disabled	C-10
1775-KA (PLC-3)	Modem	Hardware Handshaking Enabled	C-11
	Peripheral DTE	Hardware Handshaking Disabled	C-11
PLC-5 (channel 0)	Modem	Hardware Handshaking Enabled	C-12
	Peripheral DTE	Hardware Handshaking Disabled	C-12
5130-RM (PLC-5/250)	Modem	Hardware Handshaking Enabled	C-13
	Peripheral DTE	Hardware Handshaking Disabled	C-13

IBM AT to a Modem (Hardware Handshaking Enabled)

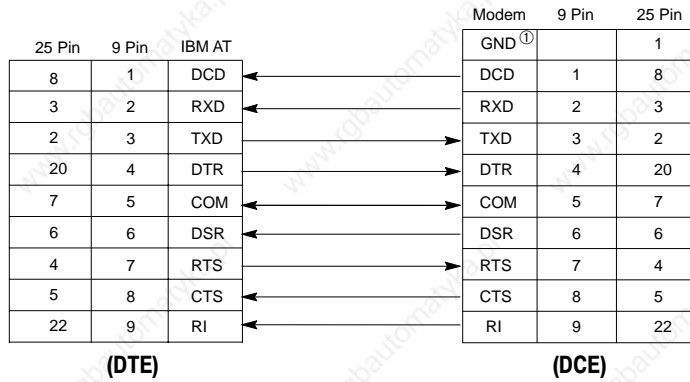

^① Connect to the shield of the cable.

IBM AT to a 5/03 Processor, 1770-KF3, 1775-KA, 1773-KA, 5130-RM, or PLC-5 (Hardware Handshaking Disabled)^①

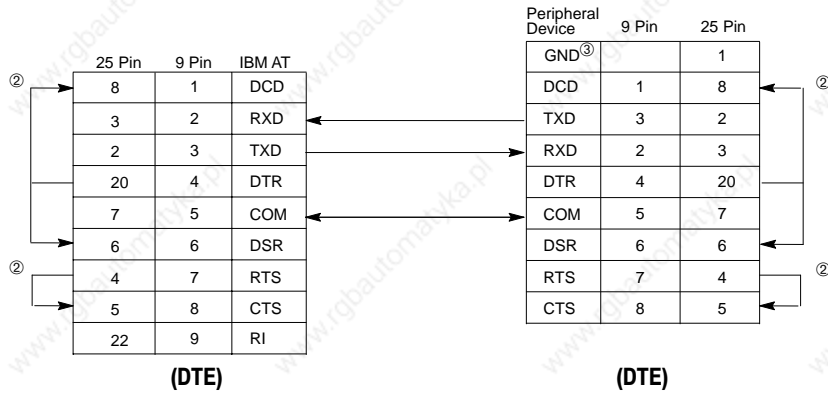

^① You can also use cable 1747-CP3.

^② Jumpers are only needed if you cannot disable the hardware handshaking on the port.

^③ Connect to the shield of the cable.

1747-KE to a Modem (Hardware Handshaking Enabled)

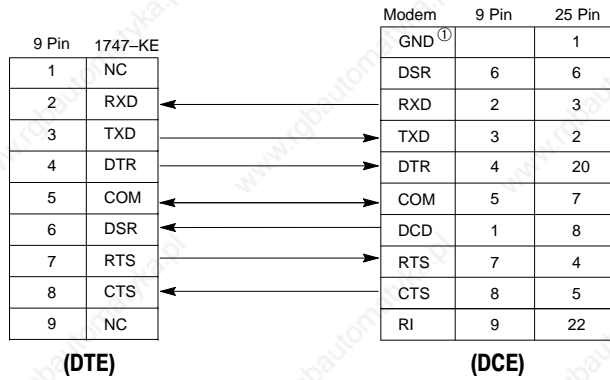

^① Connect to the shield of the cable.

1747-KE to a 5/03 Processor, IBM AT, 1770-KF3, 1775-KA, 1773-KA, 5130-RM, or PLC-5 (Hardware Handshaking Disabled)^①

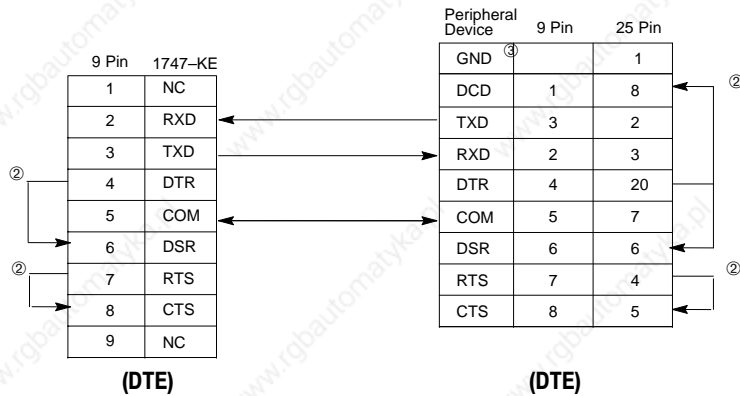

^① You can also use cable 1747-CP3.

^② Jumpers are only needed if you cannot disable the hardware handshaking on the port.

^③ Connect to the shield of the cable.

1746-BAS to a Modem (Hardware Handshaking Enabled)

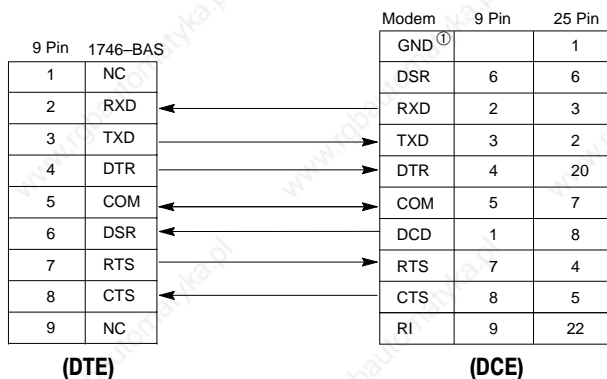

^① Connect to the shield of the cable.

1746-BAS to a 5/03 Processor, IBM AT, 1770-KF3, 1775-KA, 1773-KA, 5130-RM, or PLC-5 (Hardware Handshaking Disabled)^①

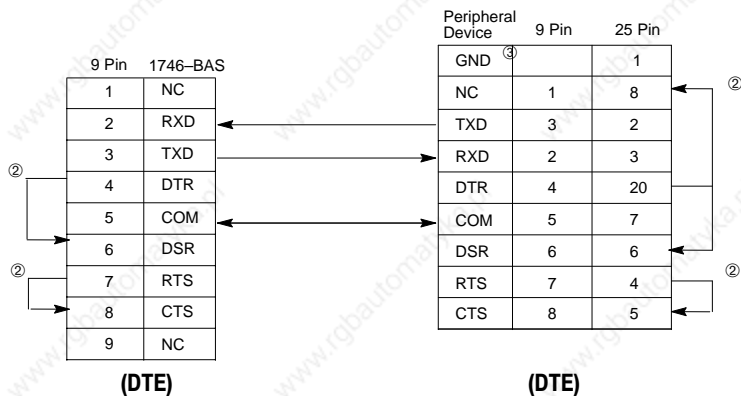

^① You can also use cable 1747-CP3.

^② Jumpers are only needed if you cannot disable the hardware handshaking on the port.

^③ Connect to the shield of the cable.

1770-KF3 to a Modem (Hardware Handshaking Enabled)

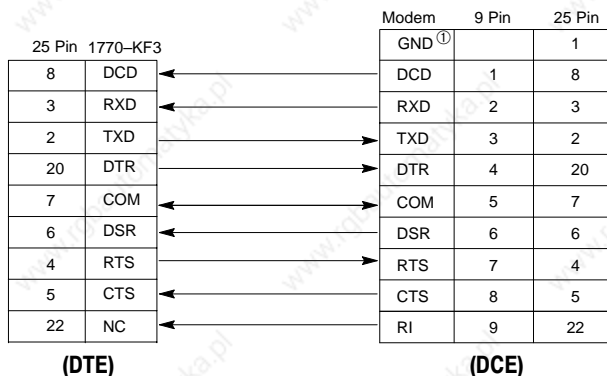

^① Connect to the shield of the cable.

2760–RB to a Modem (Hardware Handshaking Enabled)

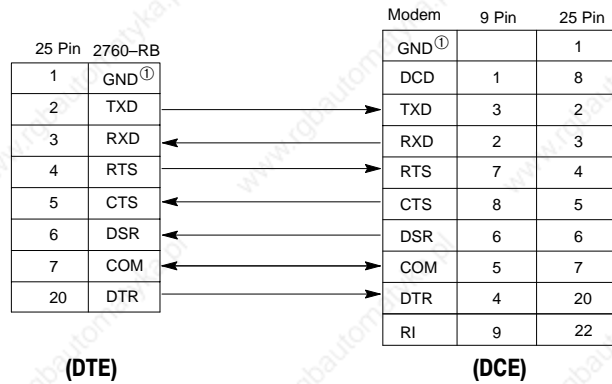

^① Connect the shield of the cable to the GND pin on one end only. Leave the other end open.

2760–RB to a 5/03 Processor, IBM AT, 1770–KF3, 1775–KA, 1773–KA, 5130–RM, or PLC–5 (Hardware Handshaking Disabled)^①

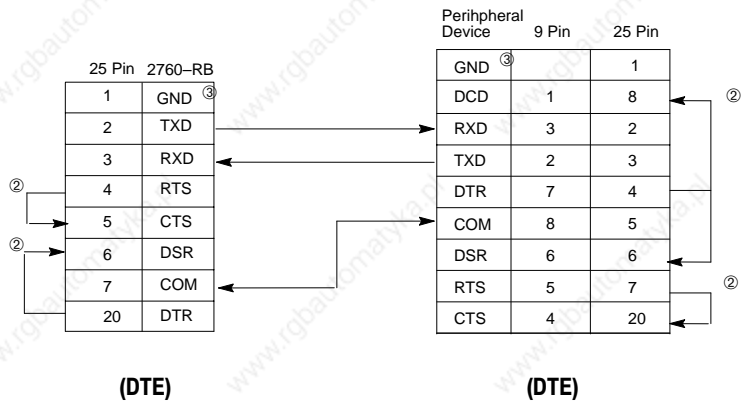

^① You can also use cable 1747–CP3.

^② Jumpers are only needed if you cannot disable the hardware handshaking on the port.

^③ Connect the shield of the cable to the GND pin on one end only. Leave the other end open.

1771-KGM to a Modem (Hardware Handshaking Enabled)

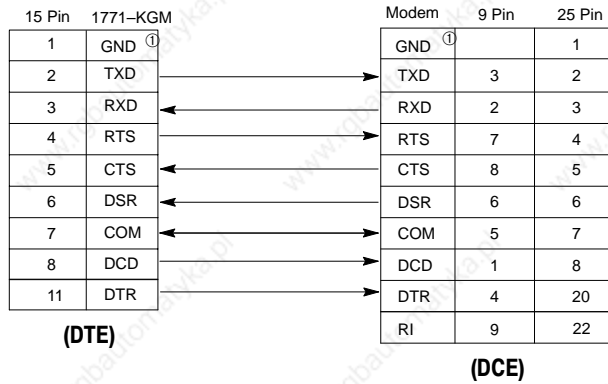

^① Connect the shield of the cable to the GND pin on one end only. Leave the other end open.

1771-KGM to a 5/03 Processor, IBM AT, 1770-KF3, 1775-KA, 1773-KA, 5130-RM, or PLC-5 (Hardware Handshaking Disabled) ^①

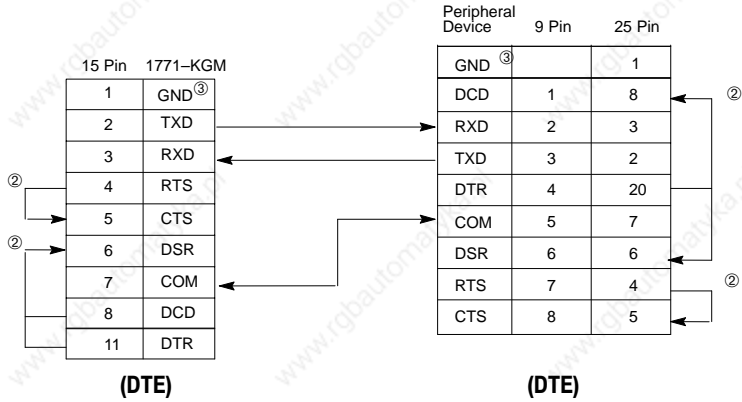

^① You can also use cable 1747-CP3.

^② Jumpers are only needed if you cannot disable the hardware handshaking on the port.

^③ Connect the shield of the cable to the GND pin on one end only. Leave the other end open.

1775-KA to a Modem (Hardware Handshaking Enabled)

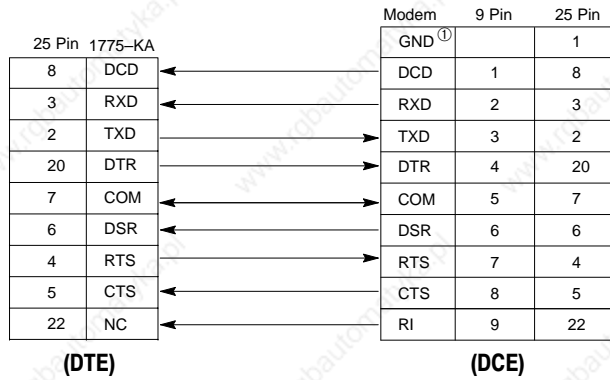

^① Connect to the shield of the cable.

1775-KA to a 5/03 Processor, IBM AT, 1770-KF3, 1773-KA, 5130-RM, or PLC-5 (Hardware Handshaking Disabled)^①

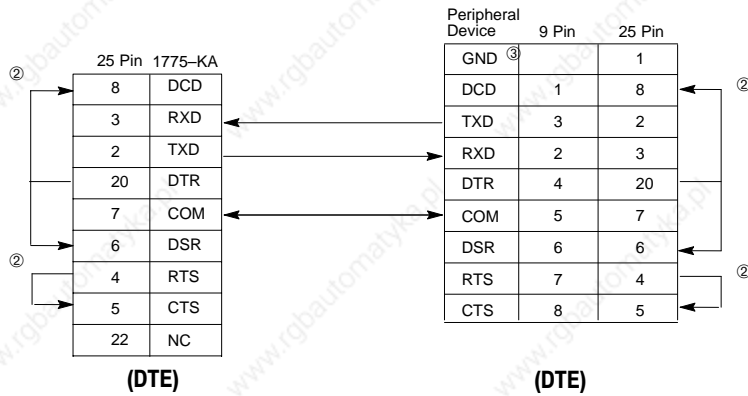

^① You can also use cable 1747-CP3.

^② Jumpers are only needed if you cannot disable the hardware handshaking on the port.

^③ Connect to the shield of the cable.

PLC-5 (Channel 0) to a Modem (Hardware Handshaking Enabled)

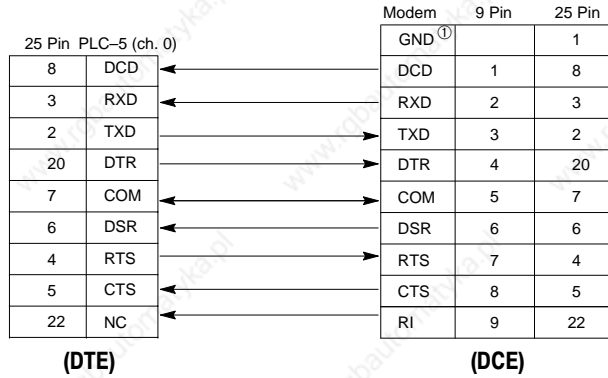

① Connect to the shield of the cable.

PLC-5 (Channel 0) to a 5/03 Processor, IBM AT, 1770-KF3, 1773-KA, 5130-RM, PLC-5, 1747-KE, or 1746-BAS (Hardware Handshaking Disabled) ①

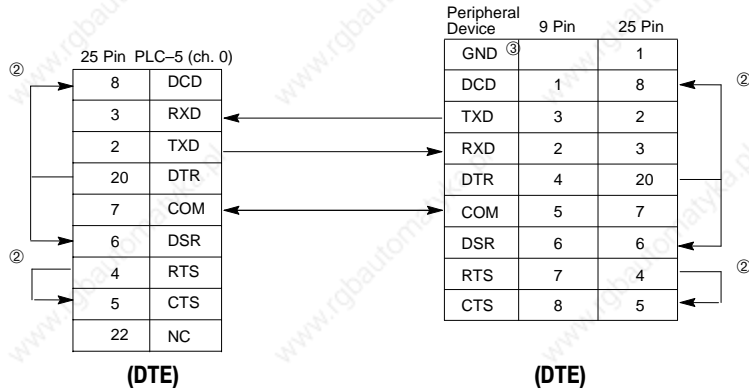

① You can also use cable 1747-CP3.

② Jumpers are only needed if you cannot disable the hardware handshaking on the port.

③ Connect to the shield of the cable.

5130–RM to a Modem (Hardware Handshaking Enabled)

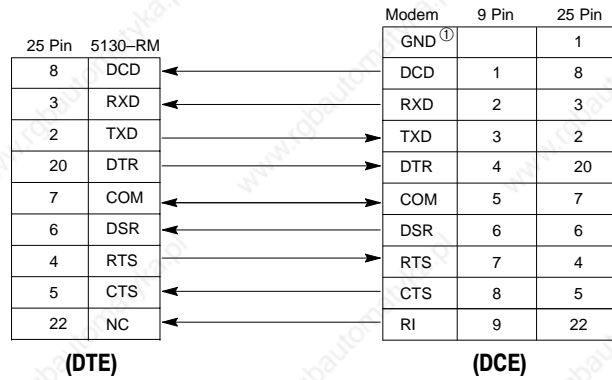

^① Connect to the shield of the cable.

5130–RM to a 5/03 Processor, IBM AT, 1770–KF3, 1773–KA, 5130–RM, PLC–5, 1747–KE, or 1746–BAS (Hardware Handshaking Disabled)^①

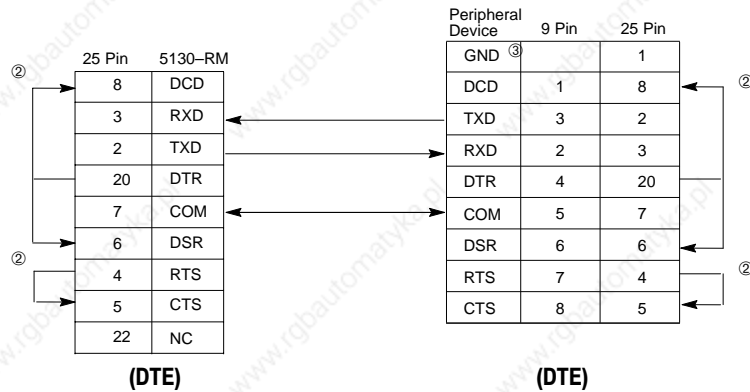

^① You can also use cable 1747–CP3.

^② Jumpers are only needed if you cannot disable the hardware handshaking on the port.

^③ Connect to the shield of the cable.

Calculating Heat Dissipation for the SLC 500 Control System

This appendix will assist you in calculating the heat dissipation of your SLC 500 control system. It consists of the following:

- definition of key terms
- table and graphs
- example heat dissipation calculation
- heat dissipation worksheet (page [D-5](#))

To select an enclosure for your SLC 500 control system, refer to chapter 1.

Definition of Key Terms

The following terms are used throughout this appendix. Familiarize yourself with them before proceeding further into the appendix.

Watts per point — maximum heat dissipation that can occur in each field wiring point when energized.

Minimum watts — amount of heat dissipation that can occur when there is no field power present.

Maximum watts — maximum amount of heat that the module generates with field power present.

Module Heat Dissipation: Calculated Watts vs. Maximum Watts

There are two ways that you can calculate heat dissipation.

Calculated Watts — if you want to determine the amount of heat generated by the points energized on your module, use the formula below for calculating the heat dissipation of each module. Then use these values for calculating the heat dissipation of your control system, which is done using the worksheet.

(number of points energized x watts per point) + minimum watts = heat dissipation of module or controller

Maximum Watts — maximum amount of heat that the module generates with field power present. Use maximum watts especially if you are not sure how many points on a module will be energized at any time.

Once you have determined which way you will calculate the heat dissipation of your modules, see the Example Worksheet for Calculating Heat Dissipation on page [D-4](#). This worksheet shows you how to calculate the heat dissipation for the example SLC control system also on page [D-4](#). Once you feel comfortable with the layout of the worksheet, go to the worksheet on page [D-5](#) and fill it out for your control system.

Appendix D**Calculating Heat Dissipation for the SLC 500 Control System****Use this Table to Calculate the Power Supply Loading**

Use the table below to calculate the power supply loading for each chassis that you have (step 1 of the worksheet).

Hardware Component	Catalog Numbers	Watts per Point	Minimum Watts	Maximum Watts
Fixed Controllers	1747-L20A	0.27	10.5	15.0
	1747-L30A	0.27	12.7	19.2
	1747-L40A	0.27	14.3	23.0
	1747-L20B	0.27	9.9	17.0
	1747-L30B	0.27	11.6	22.0
	1747-L40B	0.27	13.0	27.0
	1747-L20C	0.20	17.4	21.0
	1747-L30C	0.20	18.7	24.0
	1747-L40C	0.20	19.9	27.0
	1747-L20D	0.20	12.4	19.0
	1747-L30D	0.20	13.9	23.0
	1747-L20E	0.20	12.6	18.0
	1747-L40E	0.20	16.0	27.0
	1747-L20F	0.20	5.0	9.0
	1747-L40F	0.20	7.4	15.0
	1747-L20G	0.20	4.4	10.0
	1747-L20L	0.20	12.1	18.0
	1747-L30L	0.20	14.0	23.0
	1747-L40L	0.20	16.0	27.0
	1747-L20N	0.20	4.4	10.0
1747-L20P	0.35	8.8	17.0	
1747-L30P	0.35	10.5	23.0	
1747-L40P	0.35	11.6	28.0	
1747-L20R	0.35	10.5	16.0	
Input Modules	1746-IA4	0.27	0.175	1.30
	1746-IA8	0.27	0.250	2.40
	1746-IA16	0.27	0.425	4.80
	1746-IM4	0.35	0.175	1.60
	1746-IM8	0.35	0.250	3.10
	1746-IM16	0.35	0.425	6.00
	1746-IB8	0.20	0.250	1.90
	1746-IB16	0.20	0.425	3.60
	1746-IB32	0.20	0.530	6.90
	1746-IV8	0.20	0.250	1.90
	1746-IV16	0.20	0.425	3.60
	1746-IV32	0.20	0.530	6.90
	1746-IG16	0.020	0.700	1.00
1746-IN16	0.35	0.425	6.00	
Output Modules	1746-OA8	1.00	0.925	9.00
	1746-OA16	0.462	1.85	9.30
	1746-OB8	0.775	0.675	6.90
	1746-OB16	0.338	1.40	7.60
	1746-OB32	0.078	2.26	4.80
	1746-OV8	0.775	0.675	6.90

Appendix D**Calculating Heat Dissipation for the SLC 500 Control System**

Hardware Component	Catalog Numbers	Watts per Point	Minimum Watts	Maximum Watts
Output Modules	1746-OV16	0.388	1.40	7.60
	1746-OV32	0.078	2.26	4.80
	1746-OW4	0.133	1.31	1.90
	1746-OW8	0.138	2.59	3.70
	1746-OW16	0.033	5.17	5.70
	1746-OX8	0.825	2.59	8.60
	1746-OG16	0.033	0.900	1.50
Input & Output Modules	1746-IO4	0.27 — per input pt. 0.133 — per output pt.	0.75	1.60
	1746-IO8	0.27 — per input pt. 0.133 — per output pt.	1.38	3.00
	1746-IO12	0.27 — per input pt. 0.133 — per output pt.	2.13	4.60
Specialty Modules	1746-NI4	NA	2.17	2.2
	1746-NIO4I	NA	3.76	3.8
	1746-NIO4V	NA	3.04	3.1
	1746-NO4I	NA	4.96	5.0
	1746-NO4V	NA	3.78	3.8
	1746-BAS	NA	3.75	3.8
	1747-DCM	NA	1.8	1.8
	1747-DSN	NA	4.5	4.5
	1747-KE	NA	3.75	3.8
Peripheral Devices	1747-AIC	NA	2.0	2.0
	1747-DTAM	NA	2.5	2.5
	1747-PT1 Series A & B	NA	2.5	2.5
	1747-PIC	NA	2.0	2.0

NA — Not Applicable

Appendix D

Calculating Heat Dissipation for the SLC 500 Control System

Example Heat Dissipation Calculation

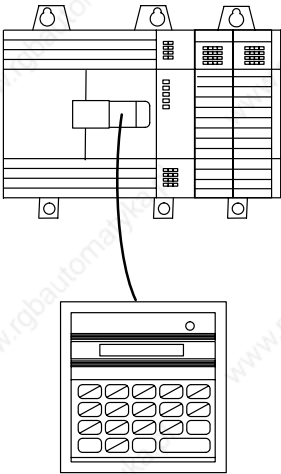

If your controller consisted of the following hardware components, you would calculate heat dissipation as shown in the *example* worksheet below.

Hardware Components	Catalog Number	Minimum Watts	Maximum Watts
Fixed Controller	1747-L20A	10.5	15.0
Input Module	1746-IA16	0.425	4.8
Output Module	1746-OA16	1.85	9.3
Peripheral Device	1747-DTAM	2.5	2.5

Example Worksheet for Calculating Heat Dissipation

Procedure	Heat Dissipation																																
<p>1. Calculate the <i>heat dissipation</i> for your fixed controller.</p> <p>Write in the watts (calculated watts or maximum watts, see page D-1) dissipated by the controller, I/O and specialty modules, and peripheral device attached to the controller. Add these values together.</p> <table style="width: 100%; border-collapse: collapse;"> <thead> <tr> <th style="width: 40%;"></th> <th style="width: 20%; text-align: center;">Catalog Number</th> <th style="width: 20%; text-align: center;">Heat Dissipation</th> <th style="width: 20%;"></th> </tr> </thead> <tbody> <tr> <td>Fixed Controller</td> <td style="text-align: center;">_____</td> <td style="text-align: center;">_____</td> <td></td> </tr> <tr> <td>Expansion Chassis</td> <td></td> <td></td> <td></td> </tr> <tr> <td style="padding-left: 20px;">Slot 1 (if applicable)</td> <td style="text-align: center;">_____</td> <td style="text-align: center;">_____</td> <td></td> </tr> <tr> <td style="padding-left: 20px;">Slot 2 (if applicable)</td> <td style="text-align: center;">_____</td> <td style="text-align: center;">_____</td> <td></td> </tr> <tr> <td>Peripheral Device</td> <td style="text-align: center;">_____</td> <td style="text-align: center;">_____</td> <td></td> </tr> <tr> <td></td> <td style="text-align: right;">Total:</td> <td style="text-align: center;">_____</td> <td></td> </tr> <tr> <td></td> <td></td> <td style="text-align: right;"><i>Place Total on this Line ----></i></td> <td style="text-align: center;">_____ W</td> </tr> </tbody> </table>		Catalog Number	Heat Dissipation		Fixed Controller	_____	_____		Expansion Chassis				Slot 1 (if applicable)	_____	_____		Slot 2 (if applicable)	_____	_____		Peripheral Device	_____	_____			Total:	_____				<i>Place Total on this Line ----></i>	_____ W	
	Catalog Number	Heat Dissipation																															
Fixed Controller	_____	_____																															
Expansion Chassis																																	
Slot 1 (if applicable)	_____	_____																															
Slot 2 (if applicable)	_____	_____																															
Peripheral Device	_____	_____																															
	Total:	_____																															
		<i>Place Total on this Line ----></i>	_____ W																														
<p>2. Convert to BTUs/hr. Multiply the total heat dissipation of your SLC 500 fixed control system by 3.414.</p>	x 3.414																																
<p>Total heat dissipation of the SLC 500 control system: _____ BTUs/hr</p>																																	

Appendix D

Calculating Heat Dissipation for the SLC 500 Control System

Worksheet for Calculating Heat Dissipation

Use this worksheet to calculate the heat dissipation for your fixed controller.

Procedure	Heat Dissipation																								
<p>1. Calculate the <i>heat dissipation</i> for your fixed controller.</p> <p>Write in the watts (calculated watts or maximum watts, see page D-1) dissipated by the controller, I/O and specialty modules, and peripheral device attached to the controller. Add these values together.</p> <table><thead><tr><th></th><th>Catalog Number</th><th>Heat Dissipation</th></tr></thead><tbody><tr><td>Fixed Controller</td><td>_____</td><td>_____</td></tr><tr><td>Expansion Chassis</td><td></td><td></td></tr><tr><td> Slot 1 (if applicable)</td><td>_____</td><td>_____</td></tr><tr><td> Slot 2 (if applicable)</td><td>_____</td><td>_____</td></tr><tr><td>Peripheral Device</td><td>_____</td><td>_____</td></tr><tr><td></td><td>Total: _____</td><td></td></tr><tr><td></td><td><i>Place Total on this Line ---></i></td><td></td></tr></tbody></table>		Catalog Number	Heat Dissipation	Fixed Controller	_____	_____	Expansion Chassis			Slot 1 (if applicable)	_____	_____	Slot 2 (if applicable)	_____	_____	Peripheral Device	_____	_____		Total: _____			<i>Place Total on this Line ---></i>		
	Catalog Number	Heat Dissipation																							
Fixed Controller	_____	_____																							
Expansion Chassis																									
Slot 1 (if applicable)	_____	_____																							
Slot 2 (if applicable)	_____	_____																							
Peripheral Device	_____	_____																							
	Total: _____																								
	<i>Place Total on this Line ---></i>																								
<p>2. Convert to BTUs/hr. Multiply the total heat dissipation of your SLC 500 fixed control system by 3.414.</p>	_____ W x 3.414																								

Total heat dissipation of the SLC 500 control system: _____ BTUs/hr





Wiring and Circuit Diagrams and Voltage Ranges for Your Fixed Controller

This appendix covers the following for your fixed controller.

- wiring diagrams
- circuit diagrams
- voltage ranges

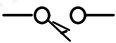
Wiring Symbols

The following table provides an explanation of the symbols used in the wiring diagrams. The symbols do not indicate the only type of I/O devices that can be connected, but rather a “typical” device. As long as your I/O device meets the I/O circuit specifications, it should be compatible.

This Symbol	Represents Typical Input Device
	Mechanical switch
	Solid-state switch
This Symbol	Represents Typical Output Device
	Solenoid
	Control relay

The connections illustrated in the wiring diagrams are shown for example purposes only.

- You can connect I/O devices in any order to the I/O circuits. If you are not going to load all of your circuits, space the connections evenly apart to help in heat dissipation.
- All the input circuits on any one fixed controller are the same with one exception: input 0 is unique for all fixed controllers which have 24 VDC input circuits. In this case, input 0 can be used as a high-speed counter. The diagrams in this appendix show the differences in operating characteristics.
- All the output circuits on any one fixed controller are the same.

In the wiring diagrams for the fixed controller with 24 VDC input circuits and 120/240 VAC line power, the User Power Source (terminals next to Power Supply terminals — “PWR OUT 24 VDC” and “PWR OUT COM”) is shown to power some input devices. This is optional. The User Power Source can provide up to 200mA at 24 VDC for input devices.

Appendix E

Wiring and Circuit Diagrams and Voltage Ranges
for Your Fixed Controller

Wiring and Circuit Diagrams and Voltage Range Locations

Use the table below to locate the appropriate wiring and circuit diagrams and voltage ranges.

Catalog Numbers	Description ^①	Wiring Diagram	Input Circuit Diagram	On/Off State Voltage	Output Circuit Diagram	Operating Voltage Range
1747-L20A	(12) 120 VAC Inputs and (8) Relay Outputs	E-4	E-5	E-5	E-5	E-5
1747-L20B	(12) 120 VAC Inputs and (8) Triac Outputs	E-6	E-7	E-7	E-7	E-7
1747-L20C	(12) 24 VDC Sinking Inputs, High-Speed Counter Input and (8) Relay Outputs	E-8	E-9	E-9	E-10	E-10
1747-L20D	(12) 24 VDC Sinking Inputs, High-Speed Counter Input and (8) Triac Outputs	E-11	E-12	E-12	E-13	E-13
1747-L20E	(12) 24 VDC Sinking Inputs, High-Speed Counter Input and (8) Transistor Sourcing Outputs	E-14	E-15	E-15	E-16	E-16
1747-L20F	(12) 24 VDC Sinking Inputs, High-Speed Counter Input and (8) Relay Outputs	E-17	E-18	E-18	E-19	E-19
1747-L20G	(12) 24 VDC Sinking Inputs, High-Speed Counter Input and (8) Transistor Sourcing Outputs	E-20	E-21	E-21	E-22	E-22
1747-L20L	(12) 24 VDC Sourcing Inputs, High-Speed Counter Input and (8) Transistor Sinking Outputs	E-23	E-24	E-24	E-25	E-25
1747-L20N	(12) 24 VDC Sourcing Inputs, High-Speed Counter Input and (8) Transistor Sinking Outputs	E-26	E-27	E-27	E-28	E-28
1747-L20P	(12) 240 VAC Inputs and (8) Triac Outputs	E-29	E-30	E-30	E-30	E-30
1747-L20R	(12) 240 VAC Inputs and (8) Relay Outputs	E-31	E-32	E-32	E-32	E-32
1747-L30A	(18) 120 VAC Inputs and (12) Relay Outputs	E-33	E-34	E-34	E-34	E-34
1747-L30B	(18) 120 VAC Inputs and (12) Triac Outputs	E-35	E-36	E-36	E-36	E-36
1747-L30C	(18) 24 VDC Sinking Inputs, High-Speed Counter Input and (12) Relay Outputs	E-37	E-38	E-38	E-39	E-39
1747-L30D	(18) 24 VDC Sinking Inputs, High-Speed Counter Input and (12) Triac Outputs	E-40	E-41	E-41	E-42	E-42
1747-L30L	(18) 24 VDC Sourcing Inputs, High-Speed Counter Input and (12) Transistor Sinking Outputs	E-43	E-44	E-44	E-45	E-45
1747-L30P	(18) 240 VAC Inputs and (12) Triac Outputs	E-46	E-47	E-47	E-47	E-47
1747-L40A	(24) 120 VAC Inputs and (16) Relay Outputs	E-48	E-49	E-49	E-49	E-49

Appendix EWiring and Circuit Diagrams and Voltage Ranges
for Your Fixed Controller

Catalog Numbers	Description ^①	Wiring Diagram	Input Circuit Diagram	On/Off State Voltage	Output Circuit Diagram	Operating Voltage Range
1747-L40B	(24) 120 VAC Inputs and (16) Triac Outputs	E-50	E-51	E-51	E-51	E-51
1747-L40C	(24) 24 VDC Sinking Inputs, High-Speed Counter Input and (16) Relay Outputs	E-52	E-53	E-53	E-54	E-54
1747-L40E	(24) 24 VDC Sinking Inputs, High-Speed Counter Input and (16) Transistor Sourcing Outputs	E-55	E-56	E-56	E-57	E-57
1747-L40F	(24) 24 VDC Sinking Inputs, High-Speed Counter Input and (16) Relay Outputs	E-58	E-59	E-59	E-60	E-60
1747-L40L	(24) 24 VDC Sourcing Inputs, High-Speed Counter Input and (16) Transistor Sinking Outputs	E-61	E-62	E-62	E-63	E-63
1747-L40P	(24) 240 VAC Inputs and (16) Triac Outputs	E-64	E-65	E-65	E-65	E-65

^① Refer to page 1-5 for line power specifications.

Appendix E

Wiring and Circuit Diagrams and Voltage Ranges
for Your Fixed Controller

Catalog Number 1747-L20A (12) 120 VAC Inputs & (8) Relay Outputs

Wiring Diagram

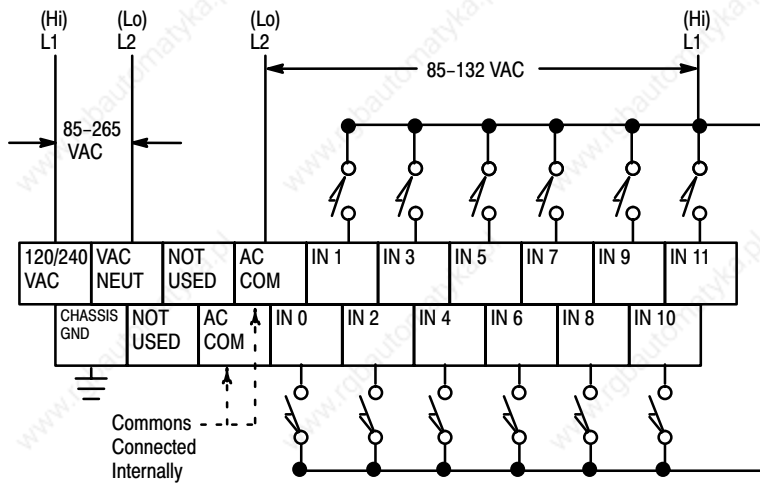
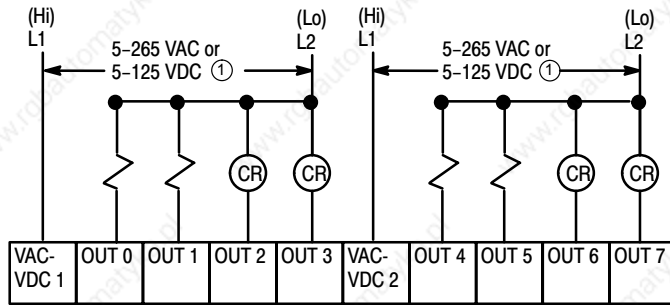

① The outputs are isolated in groups as shown. Therefore, different voltages can be applied to each group as the specific application requires.

Appendix E

Wiring and Circuit Diagrams and Voltage Ranges
for Your Fixed Controller

Input Circuit Diagram

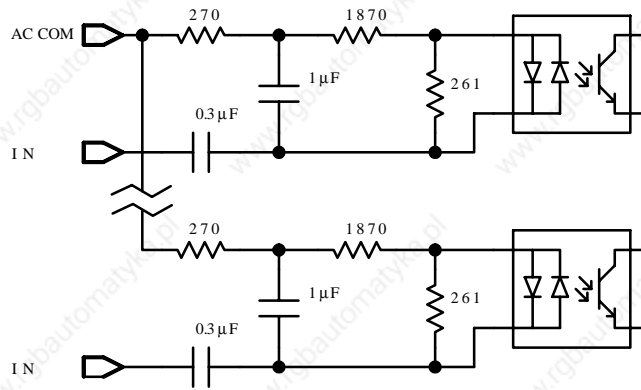

On/Off State Voltage Ranges

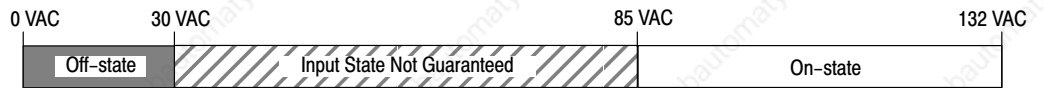

Output Circuit Diagram

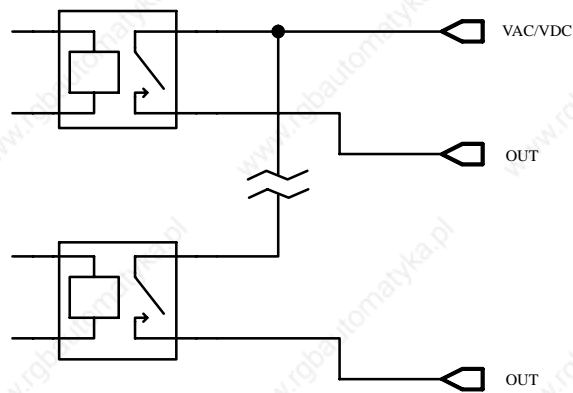

Operating Voltage Range

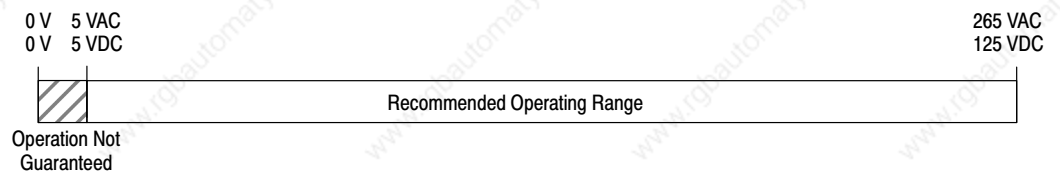

Appendix E

Wiring and Circuit Diagrams and Voltage Ranges for Your Fixed Controller

Catalog Number 1747-L20B (12) 120 VAC Inputs & (8) Triac Outputs

Wiring Diagram

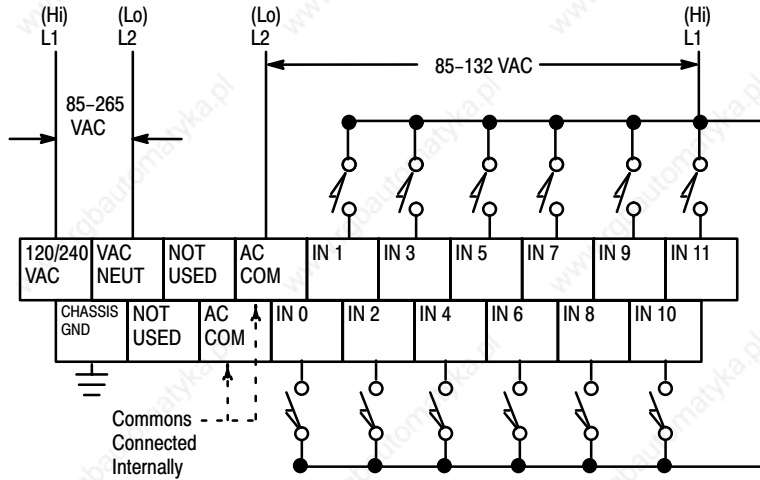
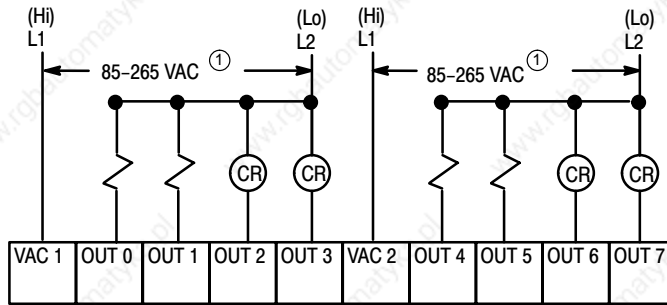

① The outputs are isolated in groups as shown. Therefore, different voltages can be applied to each group as the specific application requires.

Appendix E

Wiring and Circuit Diagrams and Voltage Ranges
for Your Fixed Controller

Input Circuit Diagram

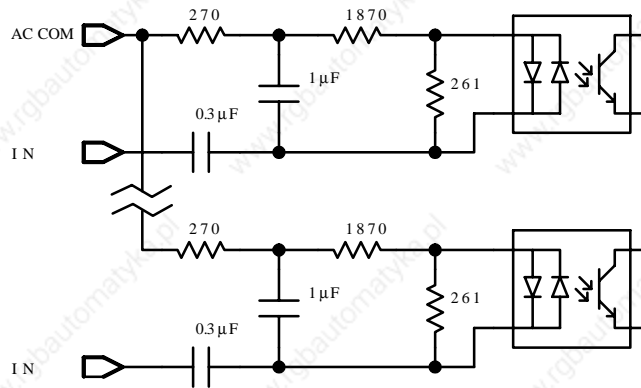

On/Off State Voltage Ranges

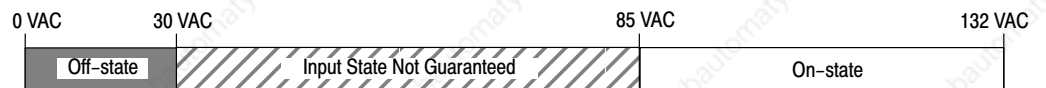

Output Circuit Diagram

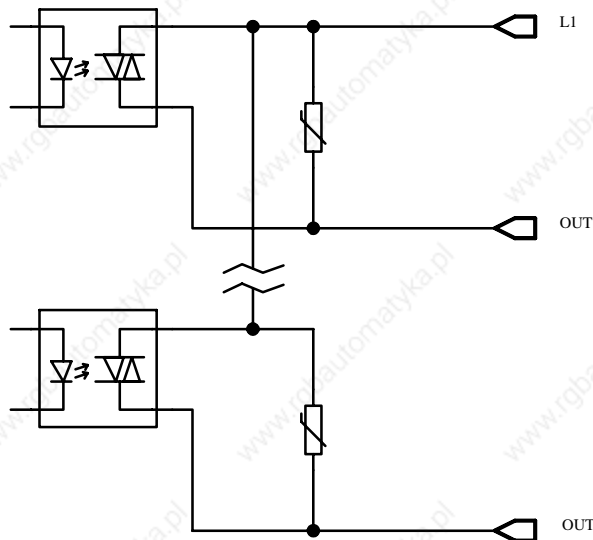

Operating Voltage Range

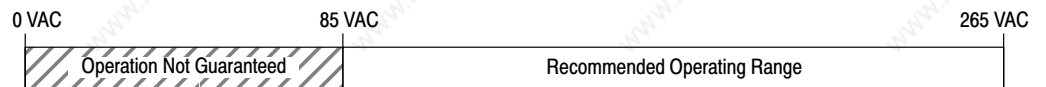

Important: If you measure the voltage at an output terminal that is not connected to a load or is connected to a high-impedance load, you may measure as much as 100 VAC even though the output is off.

Appendix E

Wiring and Circuit Diagrams and Voltage Ranges for Your Fixed Controller

Catalog Number 1747-L20C (12) 24 VDC Sinking Inputs, High-Speed Counter Input & (8) Relay Outputs

Wiring Diagram

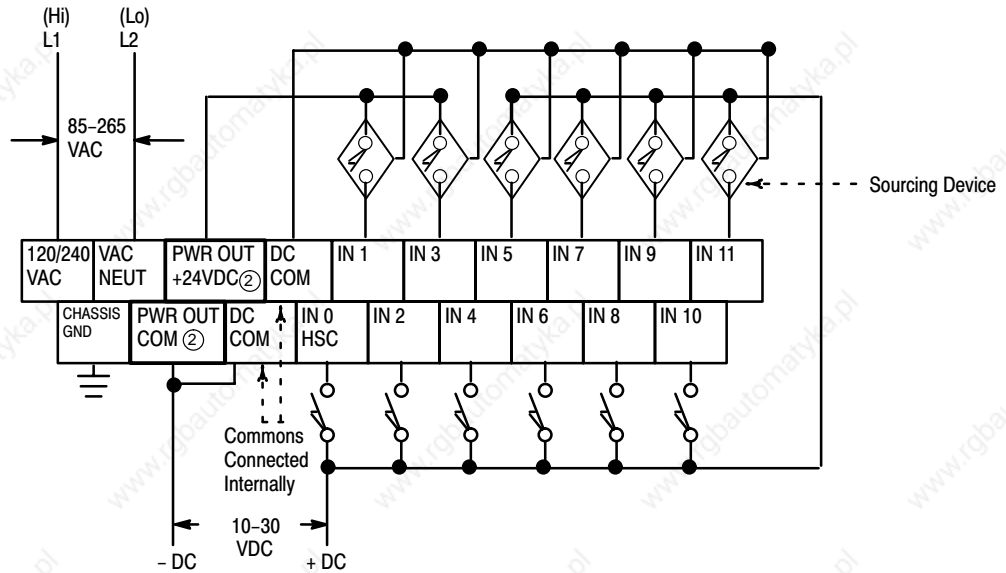
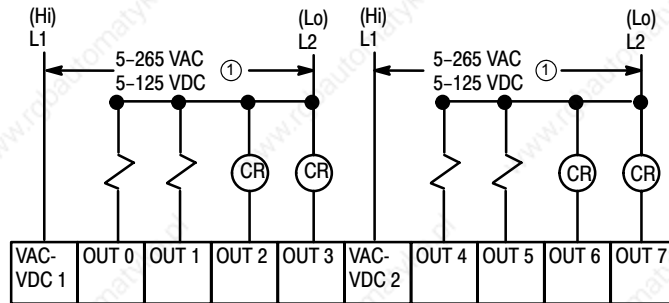

① The outputs are isolated in groups as shown. Therefore, different voltages can be applied to each group as the specific application requires.

② 24 VDC, 200mA user power is available for sensors.

Appendix E

Wiring and Circuit Diagrams and Voltage Ranges
for Your Fixed Controller

Input Circuit Diagram

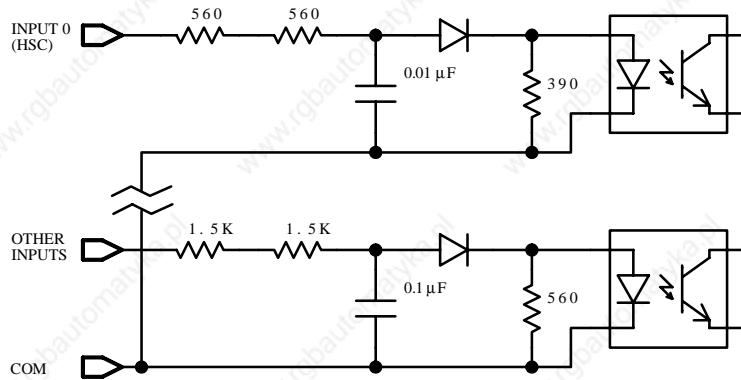

On/Off State Voltage Ranges – Input 0 (HSC)



On/Off State Voltage Ranges – All Other Inputs



Appendix E

Wiring and Circuit Diagrams and Voltage Ranges for Your Fixed Controller

Output Circuit Diagram

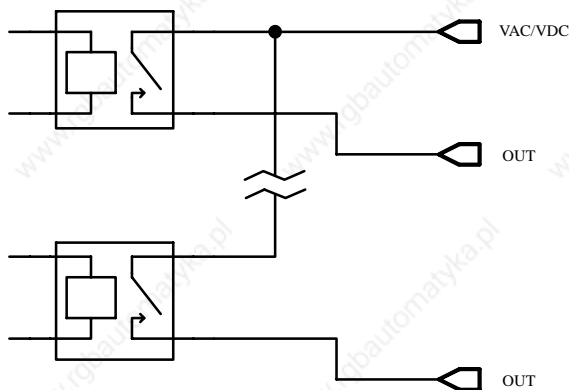

Operating Voltage Range



Appendix E

Wiring and Circuit Diagrams and Voltage Ranges
for Your Fixed Controller

Catalog Number 1747-L20D (12) 24 VDC Sinking Inputs, High-Speed Counter Input & (8) Triac Outputs

Wiring Diagram

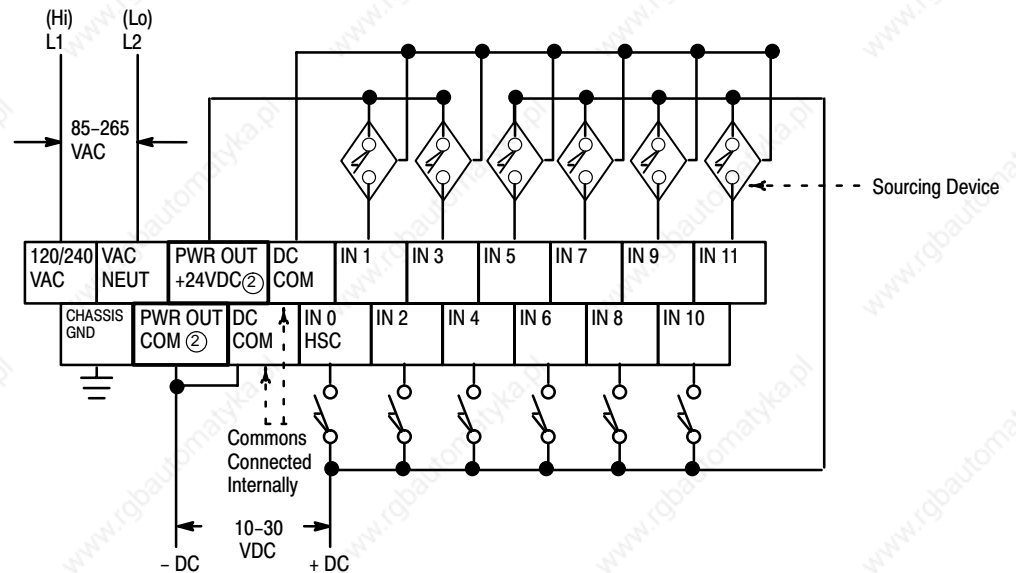
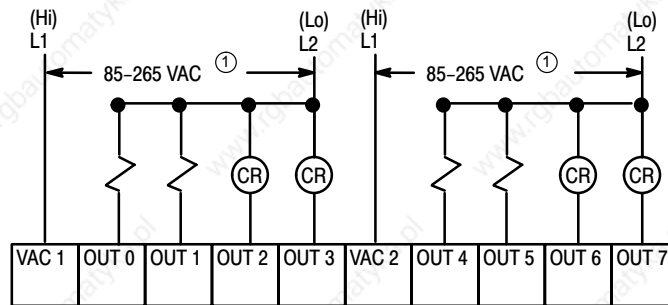

① The outputs are isolated in groups as shown. Therefore, different voltages can be applied to each group as the specific application requires.

② 24 VDC, 200mA user power is available for sensors.

Appendix E

Wiring and Circuit Diagrams and Voltage Ranges for Your Fixed Controller

Input Circuit Diagram

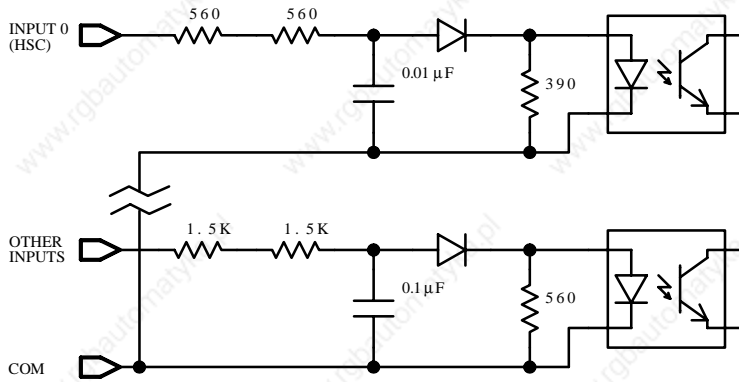

On/Off State Voltage Ranges – Input 0 (HSC)



On/Off State Voltage Ranges – All Other Inputs



Appendix E

Wiring and Circuit Diagrams and Voltage Ranges
for Your Fixed Controller

Output Circuit Diagram

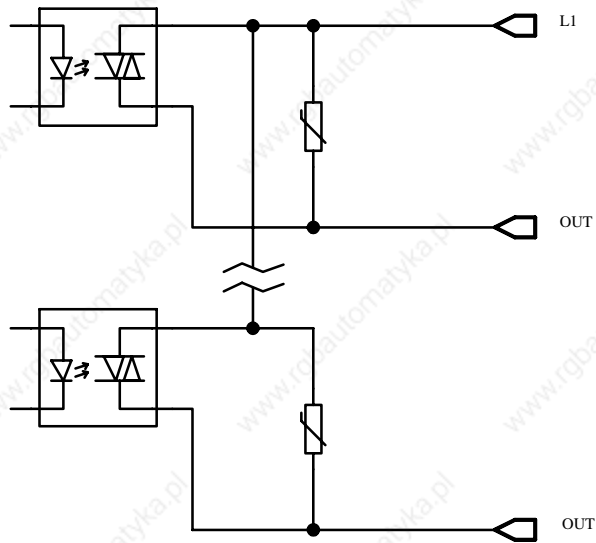

Operating Voltage Range

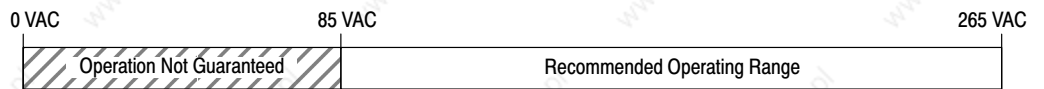

Important: If you measure the voltage at an output terminal that is not connected to a load or is connected to a high-impedance load, you may measure as much as 100 VAC even though the output is off.

Appendix E

Wiring and Circuit Diagrams and Voltage Ranges for Your Fixed Controller

Catalog Number 1747-L20E (12) 24 VDC Sinking Inputs, High-Speed Counter Input & (8) Transistor Sourcing Outputs

Wiring Diagram

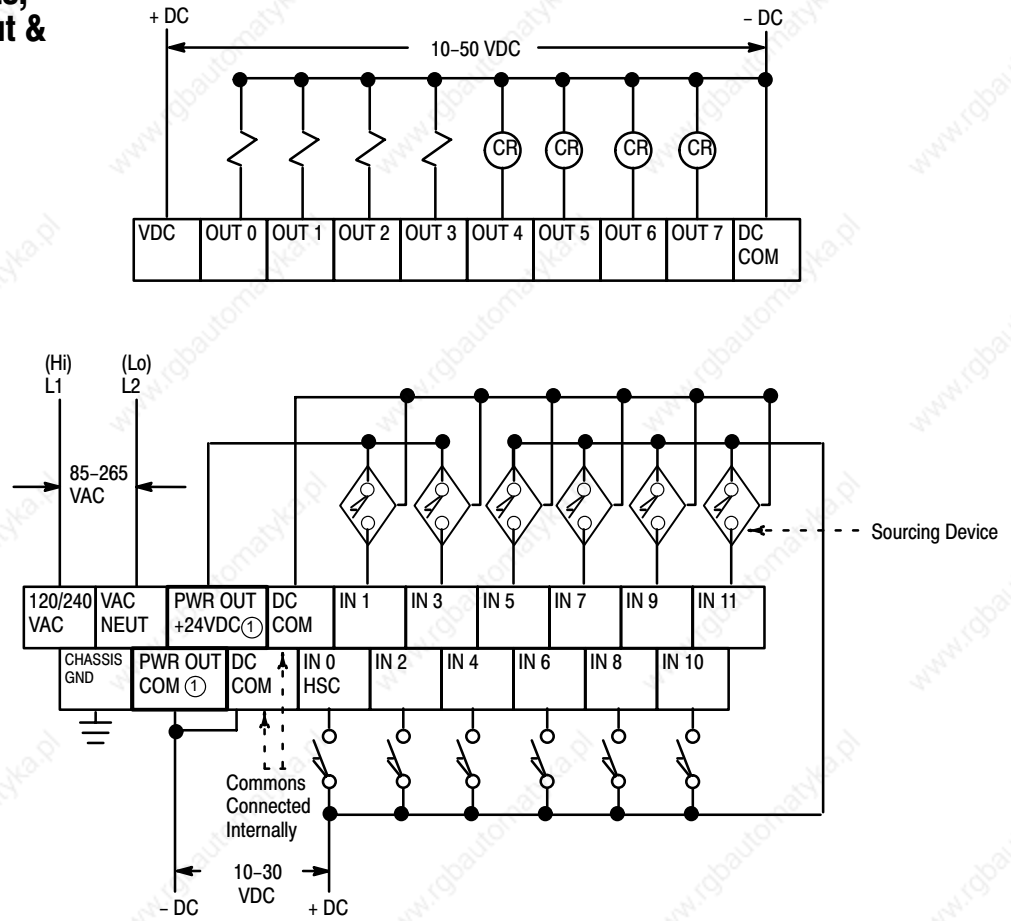

① 24 VDC, 200mA user power is available for sensors.

Appendix E

Wiring and Circuit Diagrams and Voltage Ranges
for Your Fixed Controller

Input Circuit Diagram

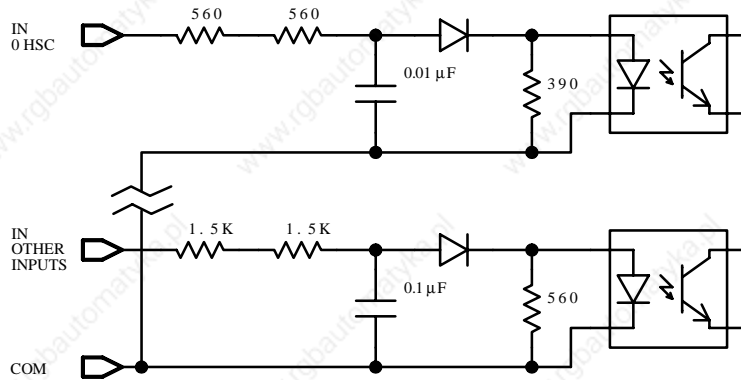

On/Off State Voltage Ranges – Input 0 (HSC)



On/Off State Voltage Ranges – All Other Inputs

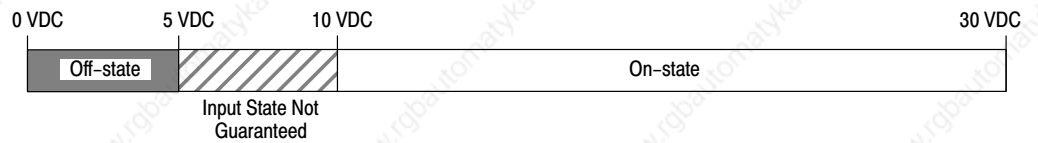

Appendix E

Wiring and Circuit Diagrams and Voltage Ranges for Your Fixed Controller

Output Circuit Diagram

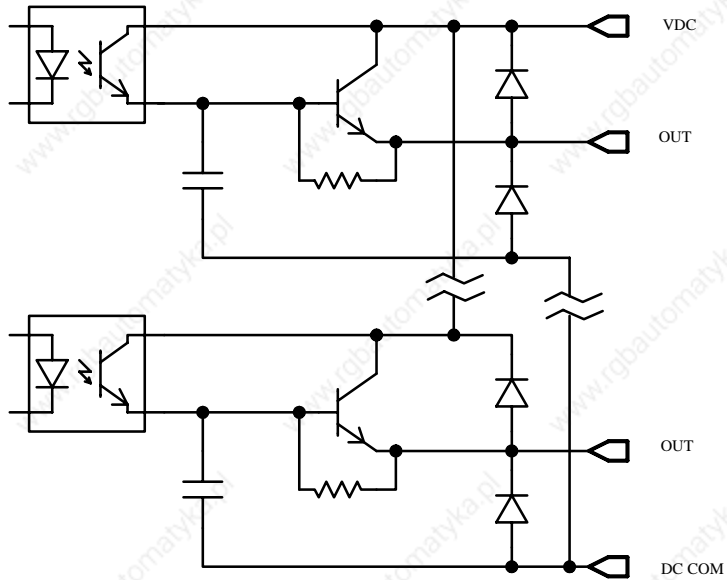

Operating Voltage Range

(Voltage is applied between +VDC and DC common.)



Appendix E

Wiring and Circuit Diagrams and Voltage Ranges for Your Fixed Controller

Catalog Number 1747-L20F (12) 24 VDC Sinking Inputs, High-Speed Counter Input & (8) Relay Outputs

Wiring Diagram

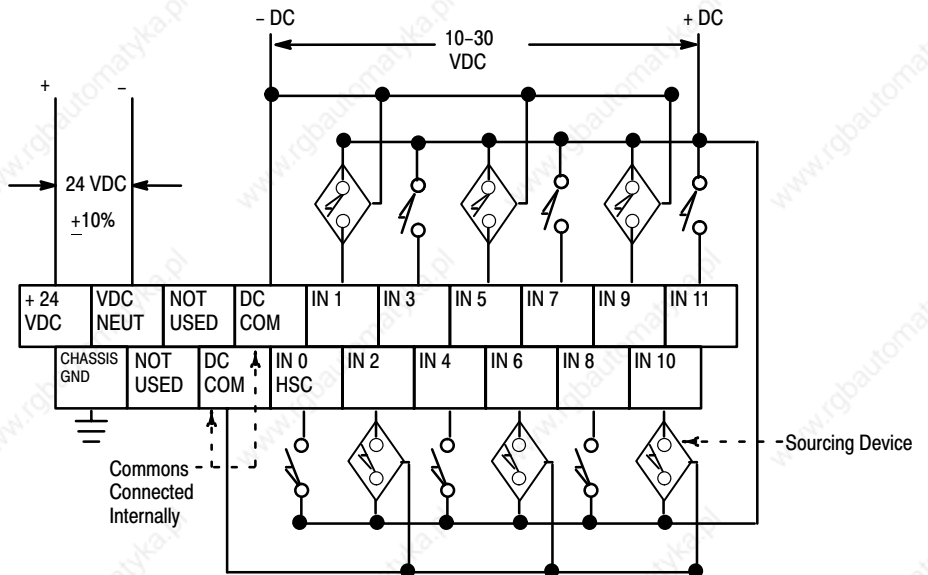
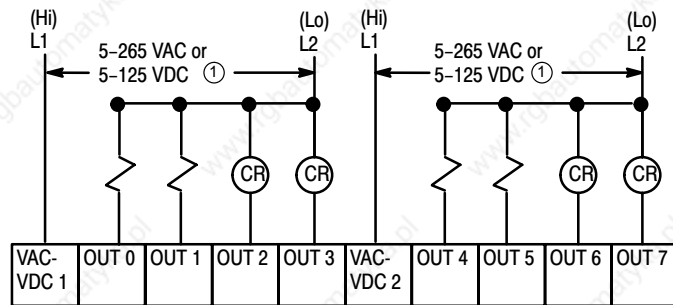

① The outputs are isolated in groups as shown. Therefore, different voltages can be applied to each group as the specific application requires.

Appendix E

Wiring and Circuit Diagrams and Voltage Ranges for Your Fixed Controller

Input Circuit Diagram

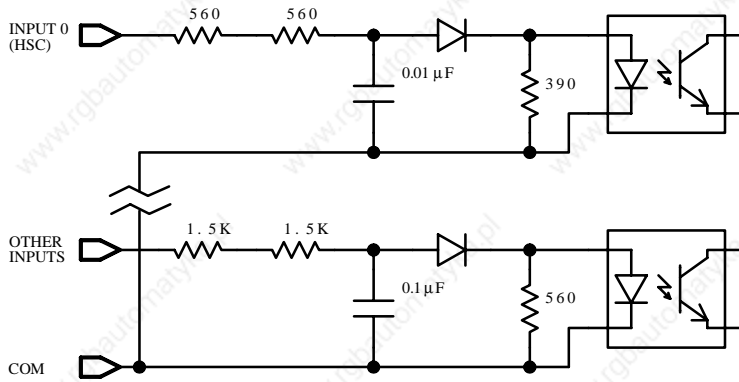

On/Off State Voltage Ranges – Input 0 (HSC)

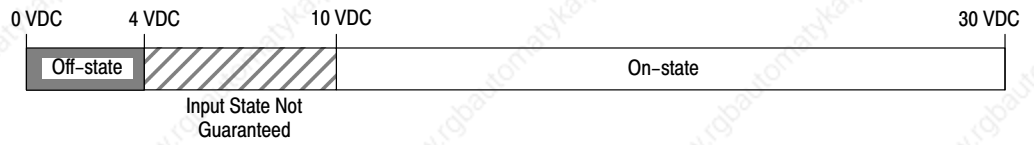

On/Off State Voltage Ranges – All Other Inputs



Appendix E

Wiring and Circuit Diagrams and Voltage Ranges
for Your Fixed Controller

Output Circuit Diagram

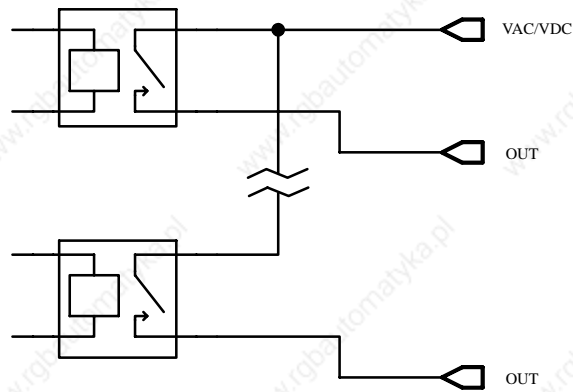

Operating Voltage Range

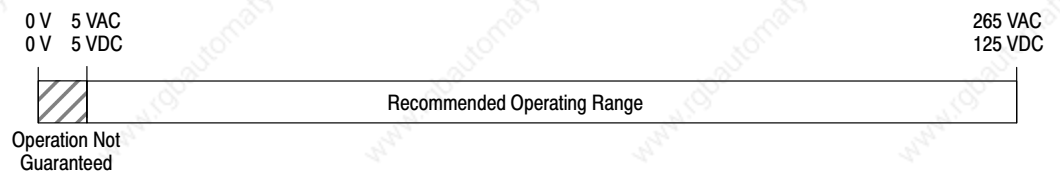

Appendix E

Wiring and Circuit Diagrams and Voltage Ranges for Your Fixed Controller

Catalog Number 1747-L20G (12) 24 VDC Sinking Inputs, High-Speed Counter Input & (8) Transistor Sourcing Outputs

Wiring Diagram

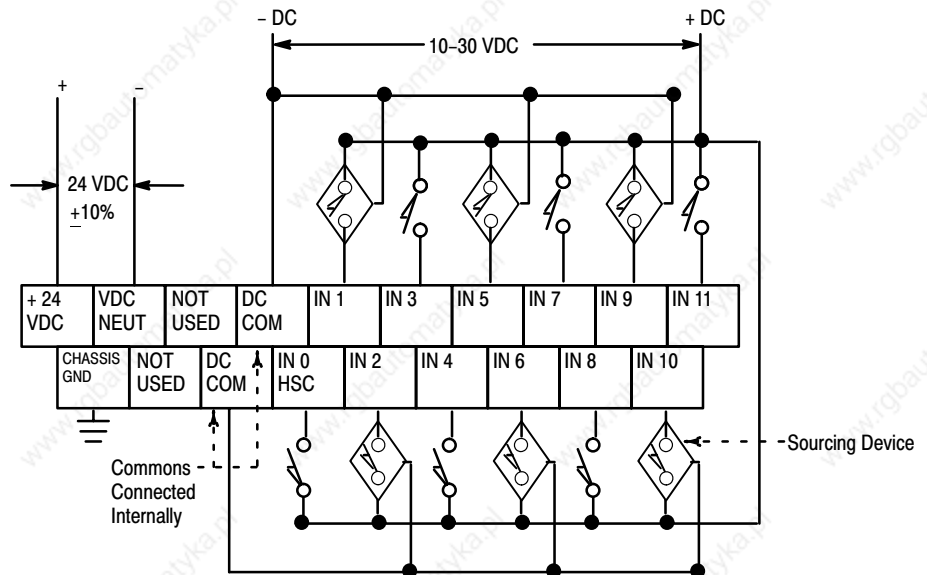
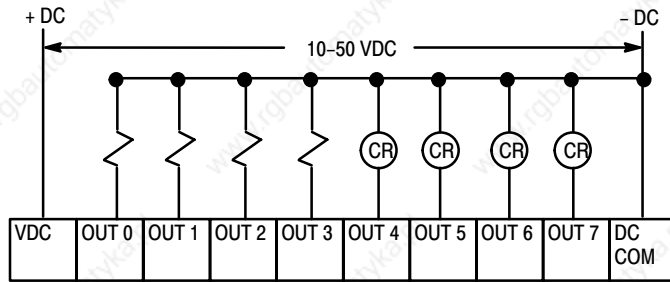

Appendix E

Wiring and Circuit Diagrams and Voltage Ranges
for Your Fixed Controller

Input Circuit Diagram

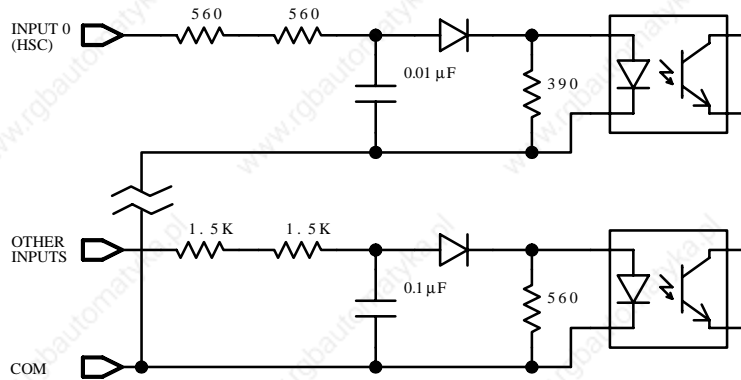

On/Off State Voltage Ranges – Input 0 (HSC)



On/Off State Voltage Ranges – All Other Inputs



Appendix E

Wiring and Circuit Diagrams and Voltage Ranges for Your Fixed Controller

Output Circuit Diagram

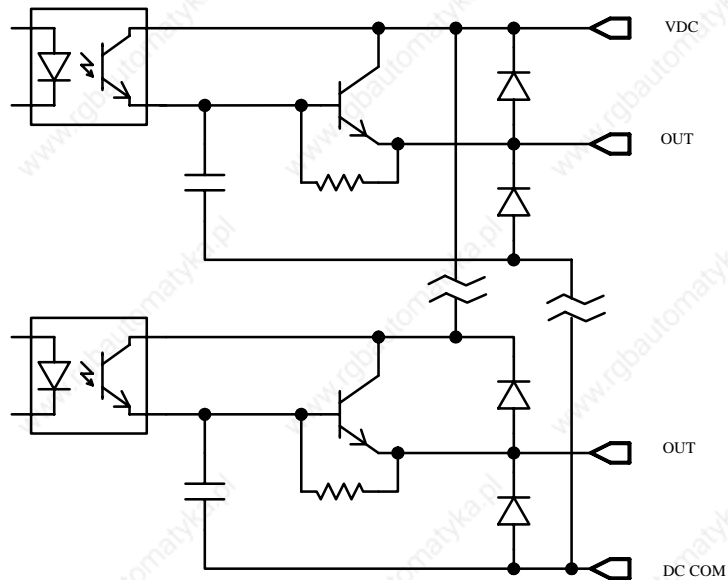

Operating Voltage Range

(Voltage is applied between +VDC and DC common.)



Appendix E

Wiring and Circuit Diagrams and Voltage Ranges for Your Fixed Controller

**Catalog Number 1747-L20L
(12) 24 VDC Sourcing Inputs,
High-Speed Counter Input &
(8) Transistor Sinking Outputs**

Wiring Diagram

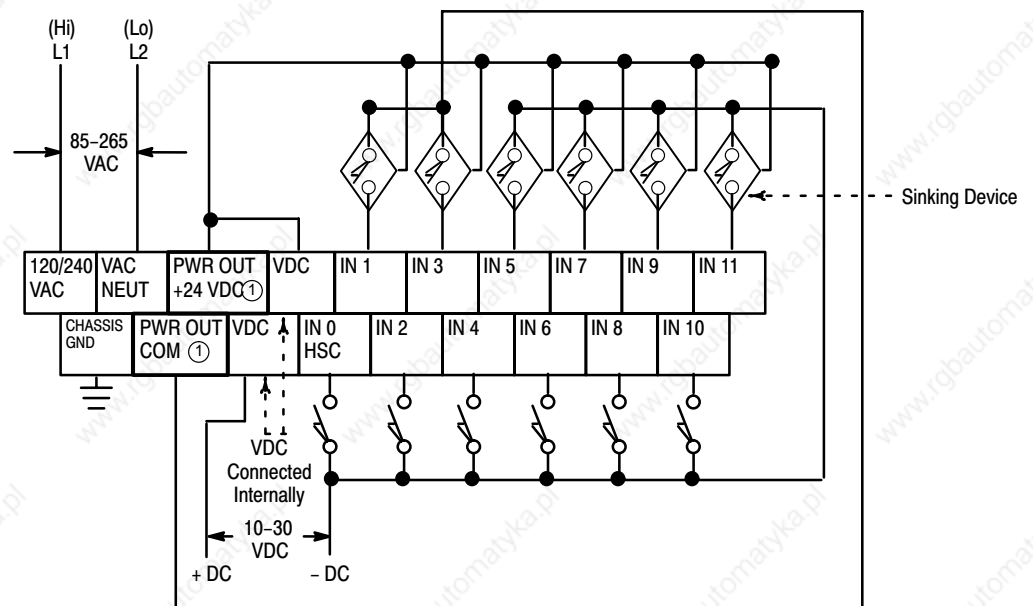
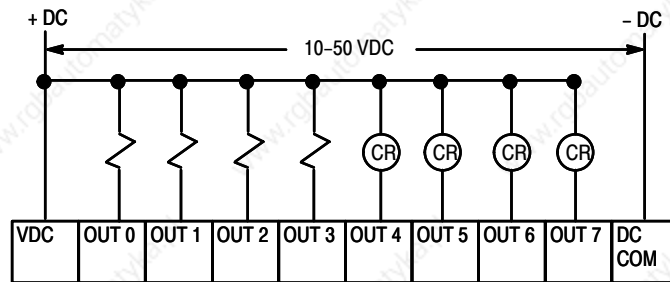

① 24 VDC, 200mA user power is available for sensors.

Appendix E

Wiring and Circuit Diagrams and Voltage Ranges for Your Fixed Controller

Input Circuit Diagram

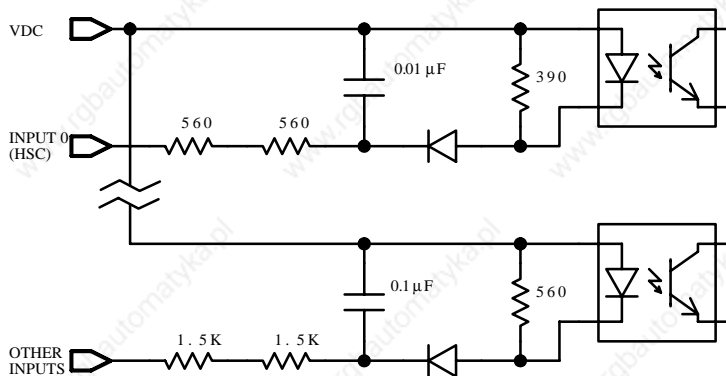

On/Off State Voltage Ranges – Input 0 (HSC)



On/Off State Voltage Ranges – All Other Inputs



Appendix E

Wiring and Circuit Diagrams and Voltage Ranges
for Your Fixed Controller

Output Circuit Diagram

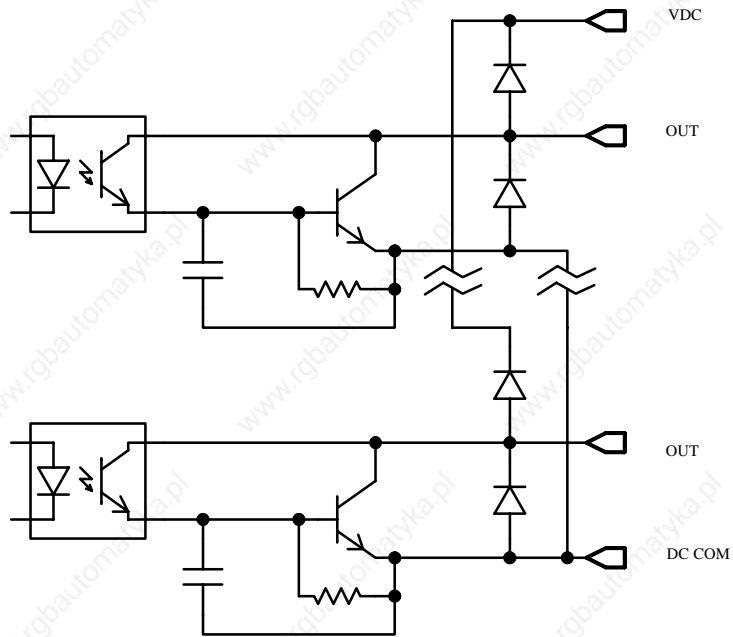

Operating Voltage Range

(Voltage is applied between +VDC
and DC common.)



Appendix E

Wiring and Circuit Diagrams and Voltage Ranges for Your Fixed Controller

Catalog Number 1747-L20N (12) 24 VDC Sourcing Inputs, High-Speed Counter Input & (8) Transistor Sinking Outputs

Wiring Diagram

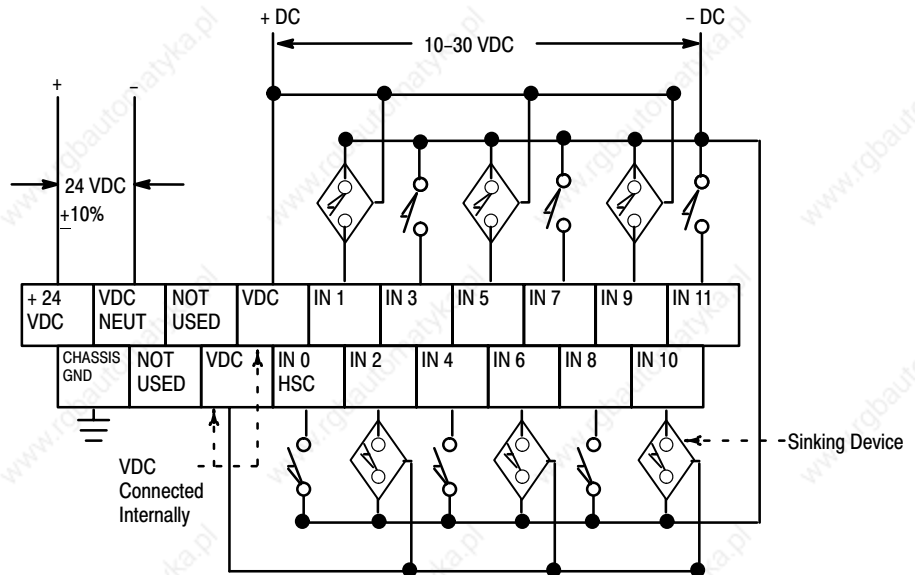
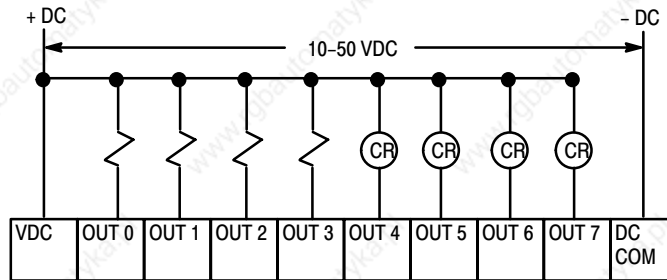

Appendix E

Wiring and Circuit Diagrams and Voltage Ranges
for Your Fixed Controller

Input Circuit Diagram

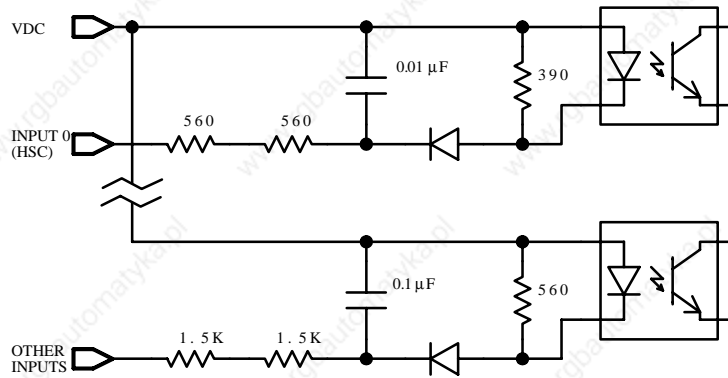

On/Off State Voltage Ranges – Input 0 (HSC)



On/Off State Voltage Ranges – All Other Inputs



Appendix E

Wiring and Circuit Diagrams and Voltage Ranges for Your Fixed Controller

Output Circuit Diagram

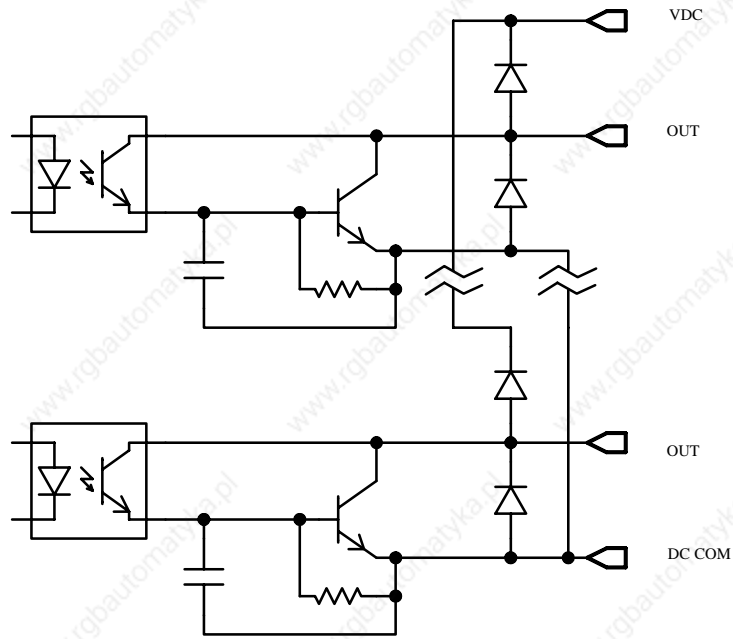

Operating Voltage Range

(Voltage is applied between +VDC and DC common.)



Appendix E

Wiring and Circuit Diagrams and Voltage Ranges for Your Fixed Controller

Catalog Number 1747-L20P (12) 240 VAC Inputs & (8) Triac Outputs

Wiring Diagram

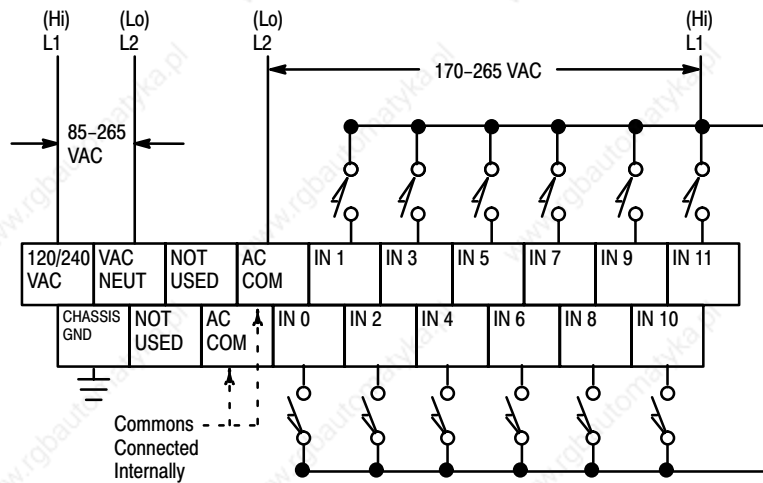
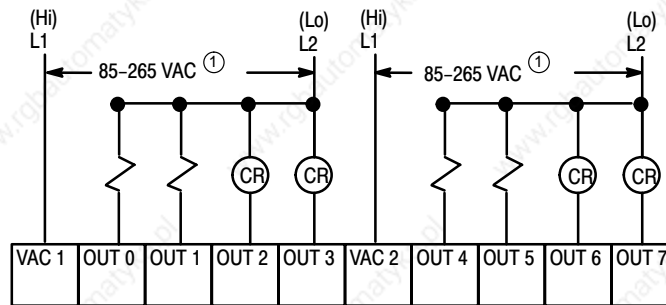

^① These outputs are isolated in groups as shown. Therefore, different voltages can be applied to each group as the specific application requires.

Appendix E

Wiring and Circuit Diagrams and Voltage Ranges for Your Fixed Controller

Input Circuit Diagram

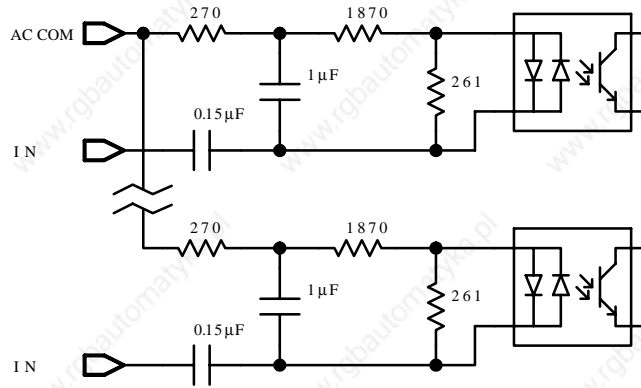

On/Off State Voltage Ranges



Output Circuit Diagram

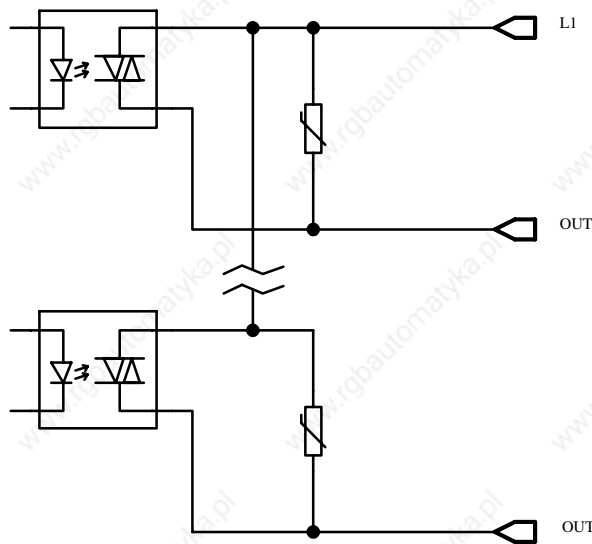

Operating Voltage Range

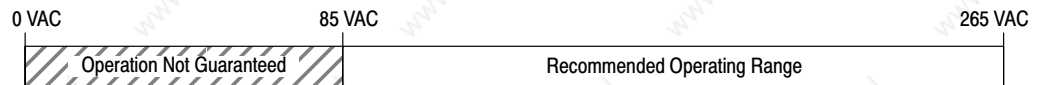

Important: If you measure the voltage at an output terminal that is not connected to a load or is connected to a high-impedance load, you may measure as much as 100 VAC even though the output is off.

Appendix E

Wiring and Circuit Diagrams and Voltage Ranges for Your Fixed Controller

Catalog Number 1747-L20R (12) 240 VAC Inputs & (8) Relay Outputs

Wiring Diagram

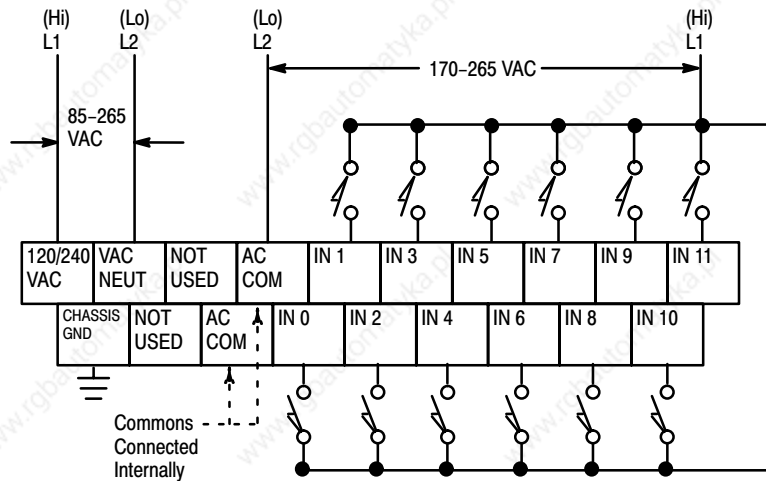
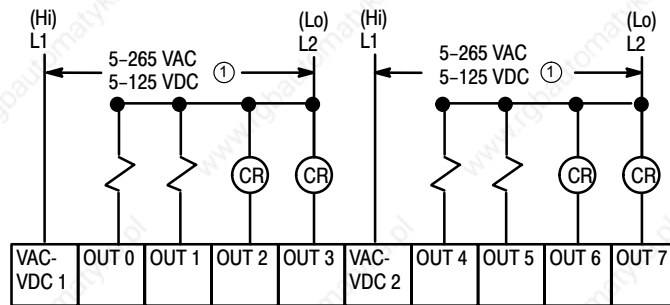

^① These outputs are isolated in groups as shown. Therefore, different voltages can be applied to each group as the specific application requires.

Appendix E

Wiring and Circuit Diagrams and Voltage Ranges for Your Fixed Controller

Input Circuit Diagram

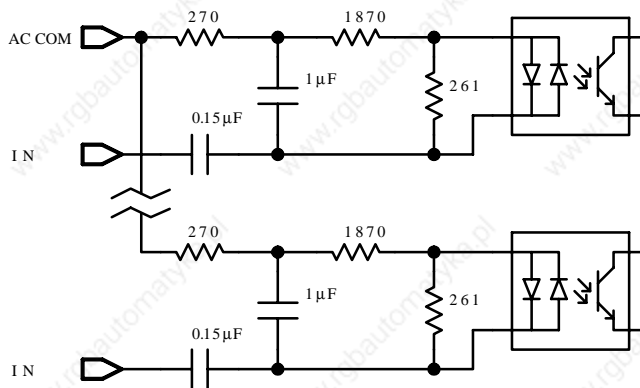

On/Off State Voltage Ranges



Output Circuit Diagram

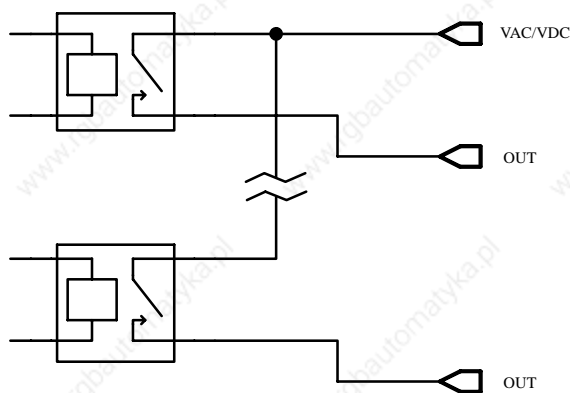

Operating Voltage Range



Catalog Number 1747-L30A **Wiring Diagram**
(18) 120 VAC Inputs & (12)
Relay Outputs

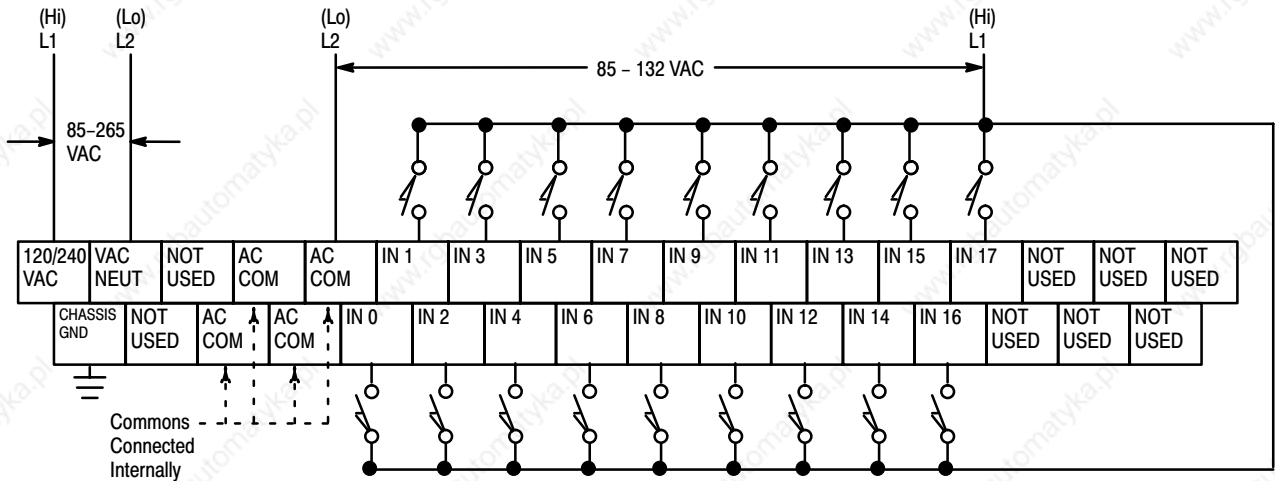
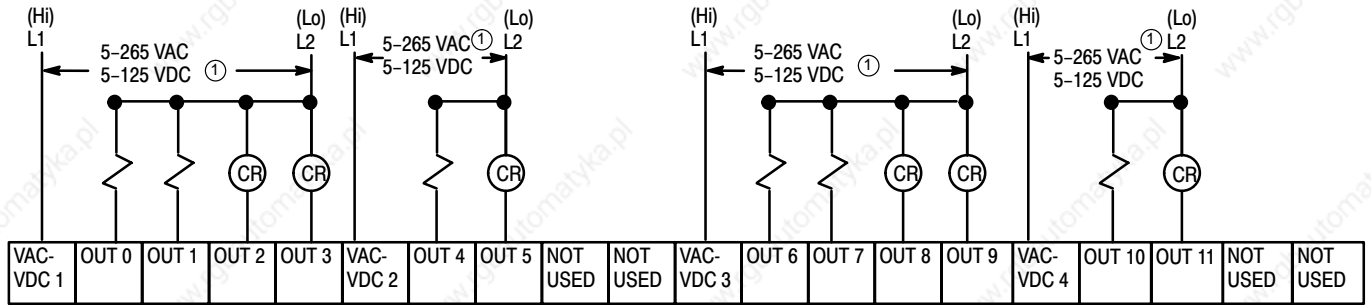

① These outputs are isolated in groups as shown. Therefore, different voltages can be applied to each group as the specific application requires.

Appendix E

Wiring and Circuit Diagrams and Voltage Ranges for Your Fixed Controller

Input Circuit Diagram

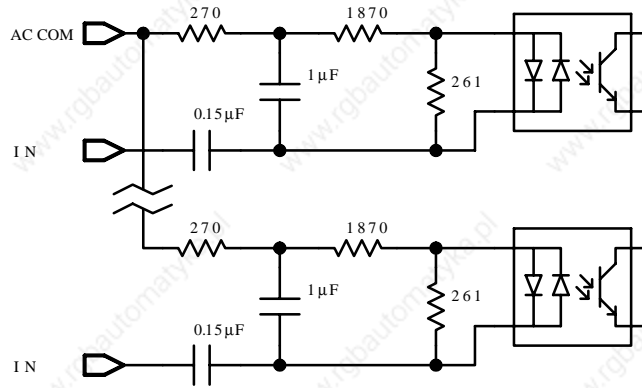

On/Off State Voltage Ranges

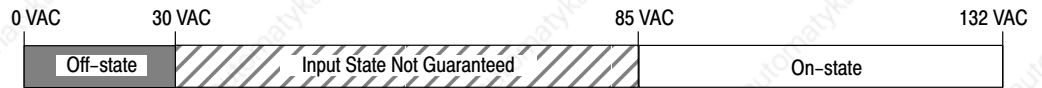

Output Circuit Diagram

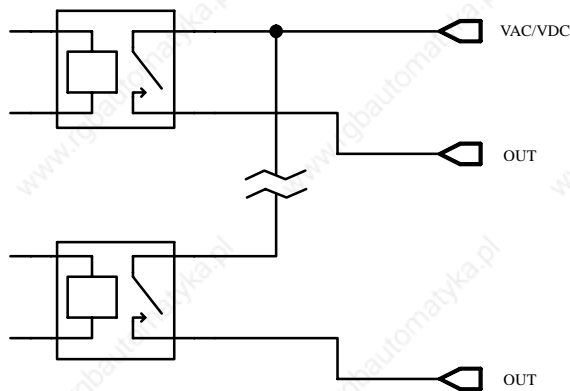

Operating Voltage Range

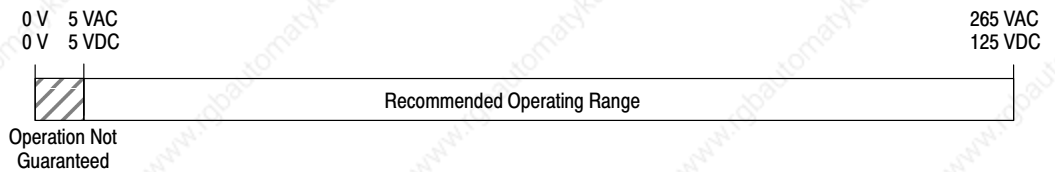

Catalog Number 1747-L30B **Wiring Diagram**
(18) 120 Vac Inputs & (12)
Triac Outputs

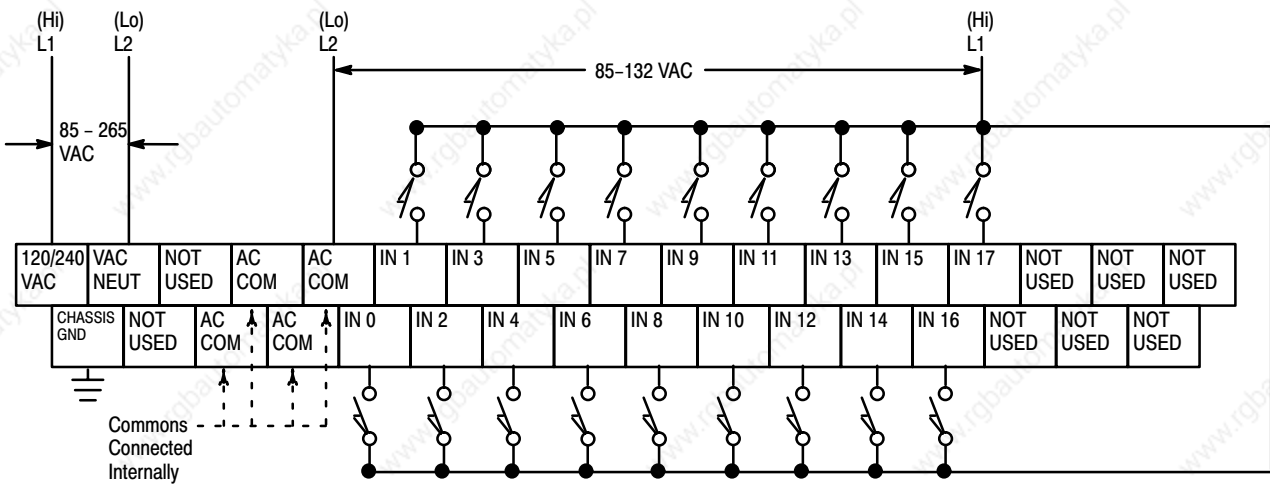
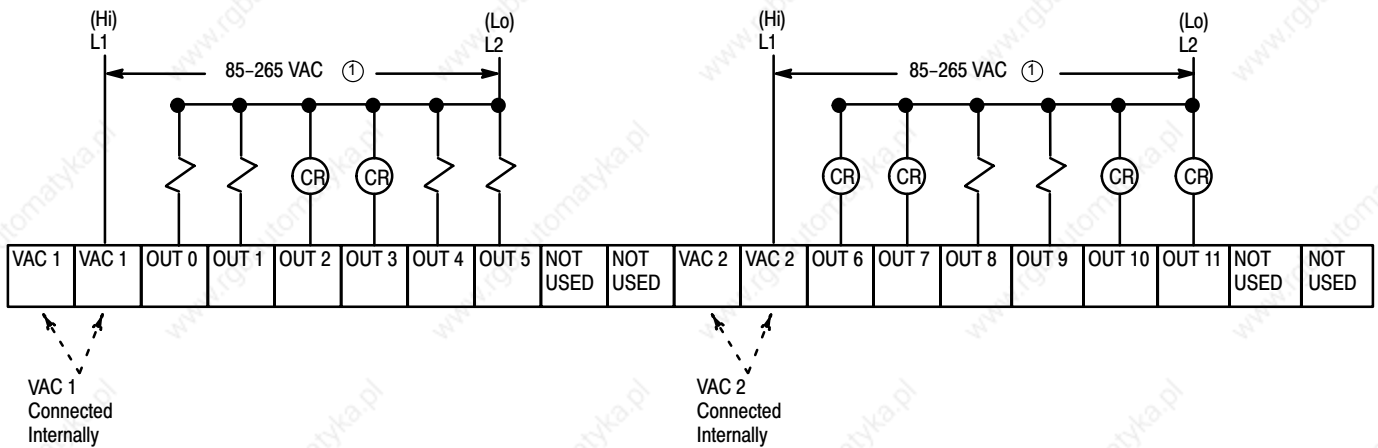

① These outputs are isolated in groups as shown. Therefore, different voltages can be applied to each group as the specific application requires.

Appendix E

Wiring and Circuit Diagrams and Voltage Ranges for Your Fixed Controller

Input Circuit Diagram

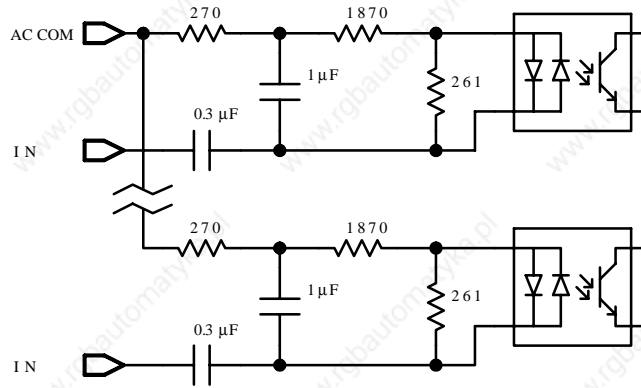

On/Off State Voltage Ranges



Output Circuit Diagram

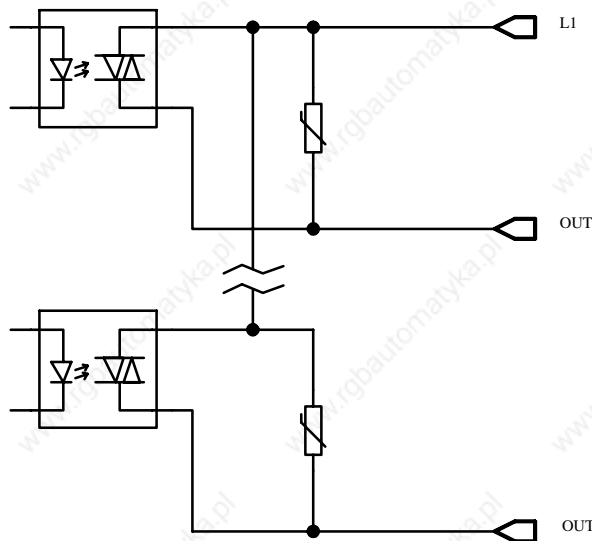

Operating Voltage Range

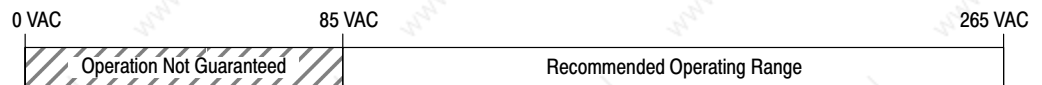

Important: If you measure the voltage at an output terminal that is not connected to a load or is connected to a high-impedance load, you may measure as much as 100 VAC even though the output is off.

Catalog Number 1747-L30C **Wiring Diagram**
(18) 24 VDC Sinking Inputs,
High-Speed Counter Input &
(12) Relay Outputs

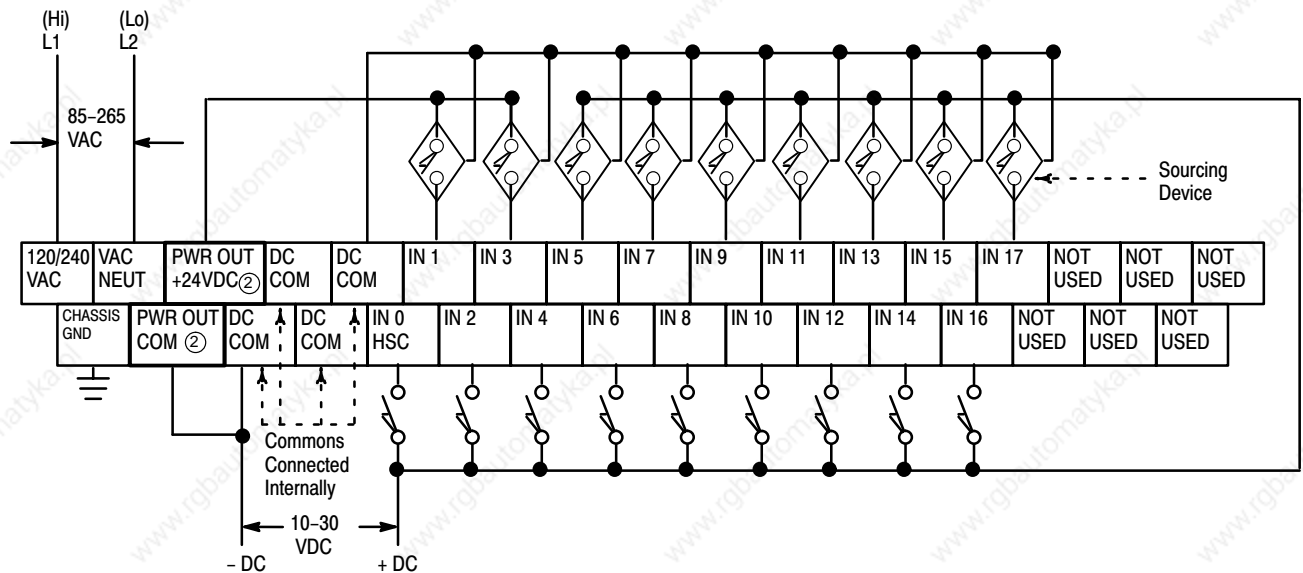
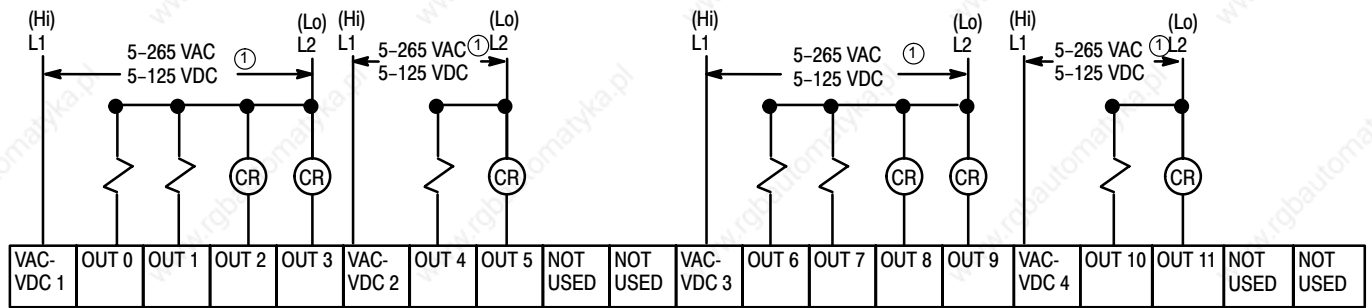

^① The outputs are isolated in groups as shown. Therefore, different voltages can be applied to each group as the specific application requires.
^② 24 VDC, 200mA user power is available for sensors.

Appendix E

Wiring and Circuit Diagrams and Voltage Ranges for Your Fixed Controller

Input Circuit Diagram

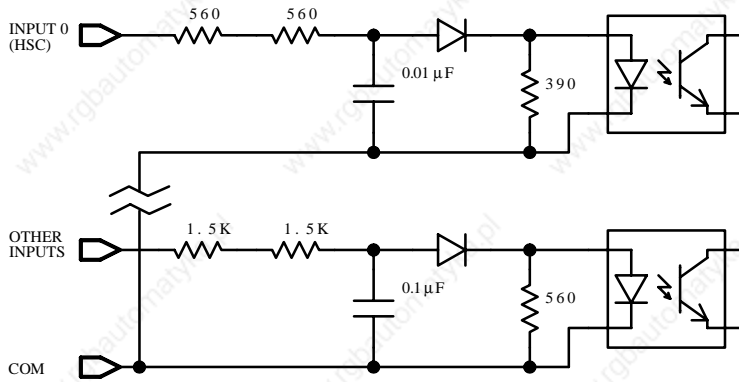

On/Off State Voltage Ranges – Input 0 (HSC)



On/Off State Voltage Ranges – All Other Inputs



Appendix E

Wiring and Circuit Diagrams and Voltage Ranges
for Your Fixed Controller

Output Circuit Diagram

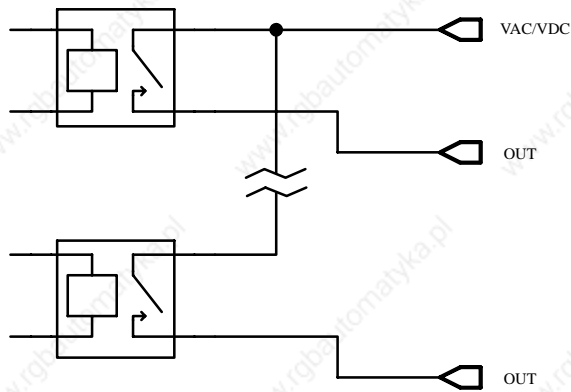

Operating Voltage Range

0 V 5 VAC
0 V 5 VDC

265 VAC
125 VDC

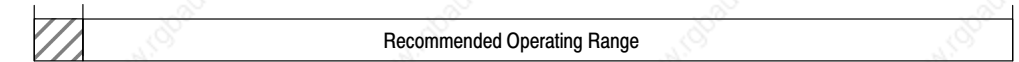

Appendix E

Wiring and Circuit Diagrams and Voltage Ranges for Your Fixed Controller

Catalog Number 1747-L30D Wiring Diagram (18) 24 VDC Sinking Inputs, High-Speed Counter Input & (12) Triac Outputs

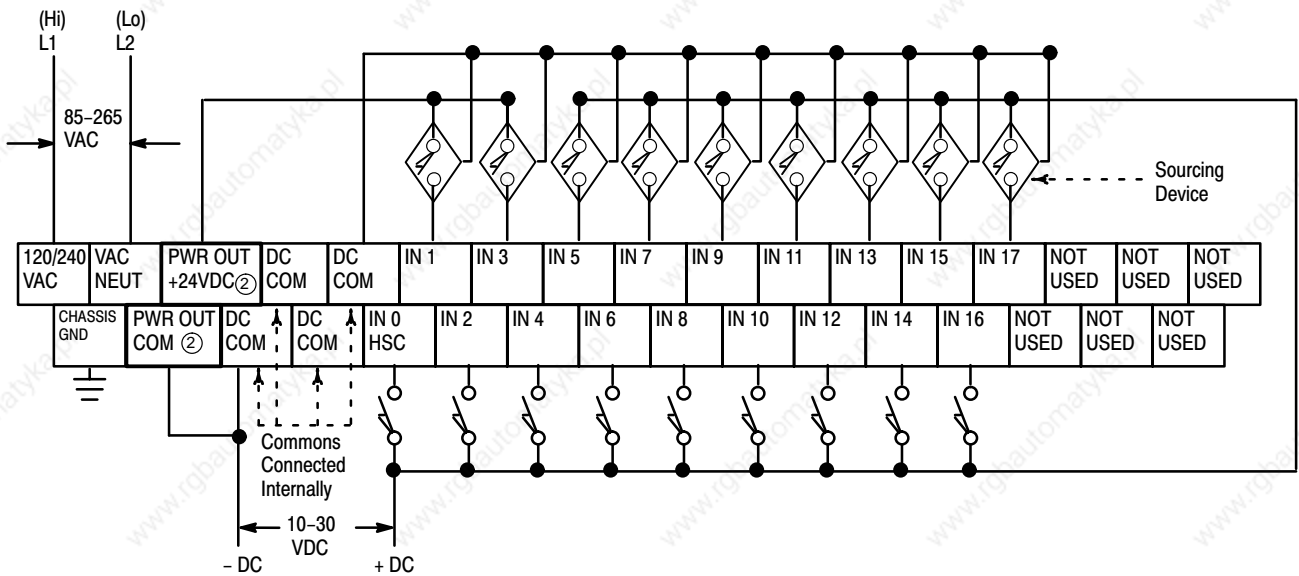
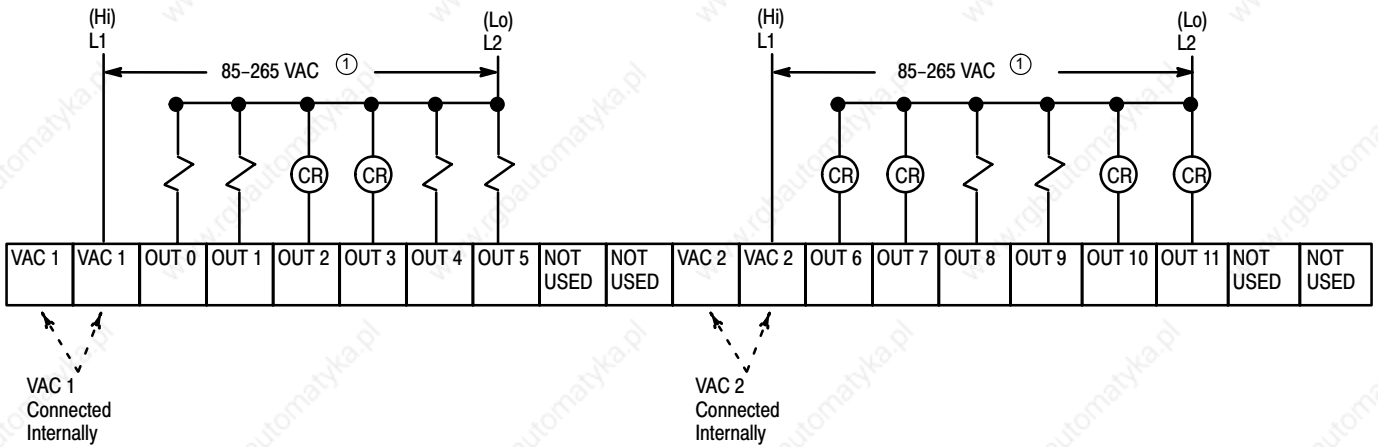

① The outputs are isolated in groups as shown. Therefore, different voltages can be applied to each group as the specific application requires.

② 24 VDC, 200mA user power is available for sensors.

Appendix E

Wiring and Circuit Diagrams and Voltage Ranges
for Your Fixed Controller

Input Circuit Diagram

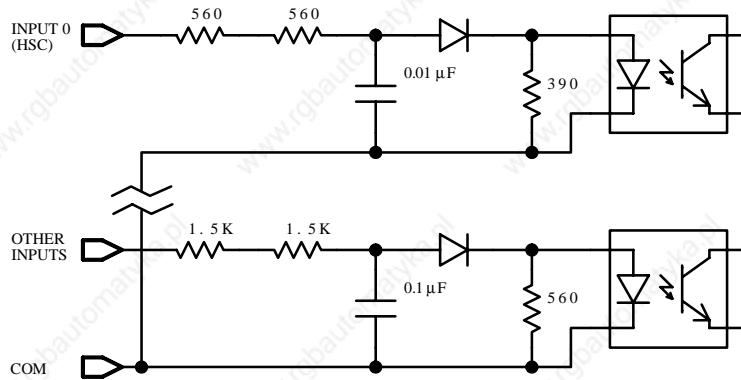

On/Off State Voltage Ranges – Input 0 (HSC)



On/Off State Voltage Ranges – All Other Inputs

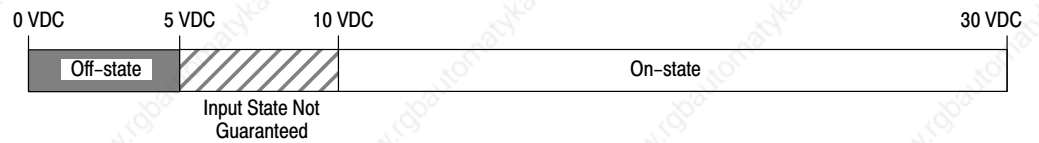

Appendix E

Wiring and Circuit Diagrams and Voltage Ranges for Your Fixed Controller

Output Circuit Diagram

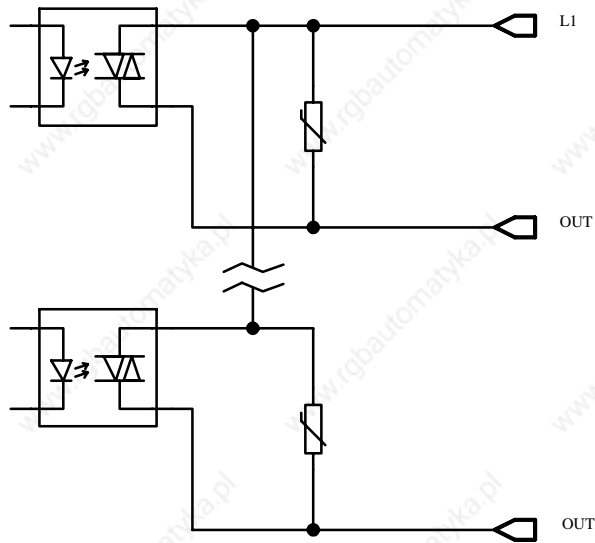

Operating Voltage Range

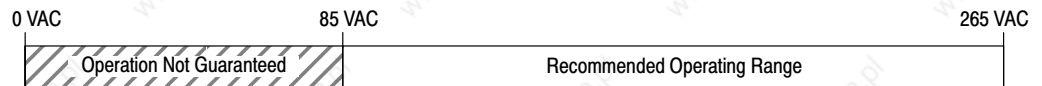

Important: If you measure the voltage at an output terminal that is not connected to a load or is connected to a high-impedance load, you may measure as much as 100 VAC even though the output is off.

Appendix E

Wiring and Circuit Diagrams and Voltage Ranges for Your Fixed Controller

Catalog Number 1747-L30L Wiring Diagram (18) 24 VDC Sourcing Inputs, High-Speed Counter Input & (12) Transistor Sinking Outputs

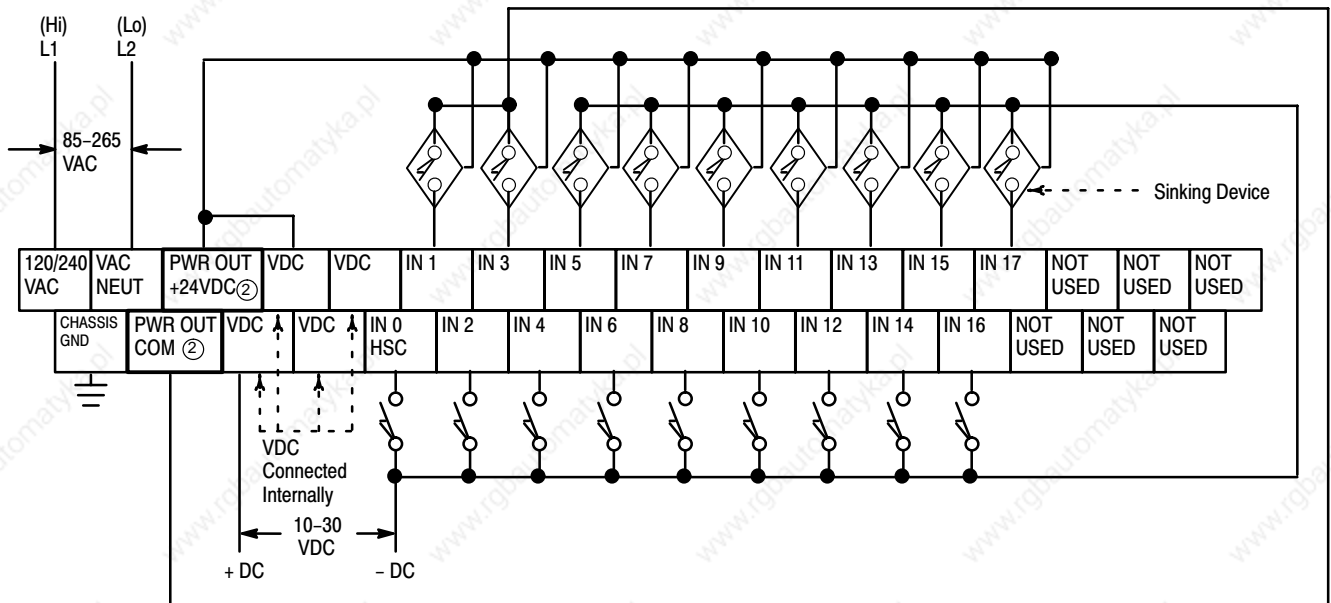
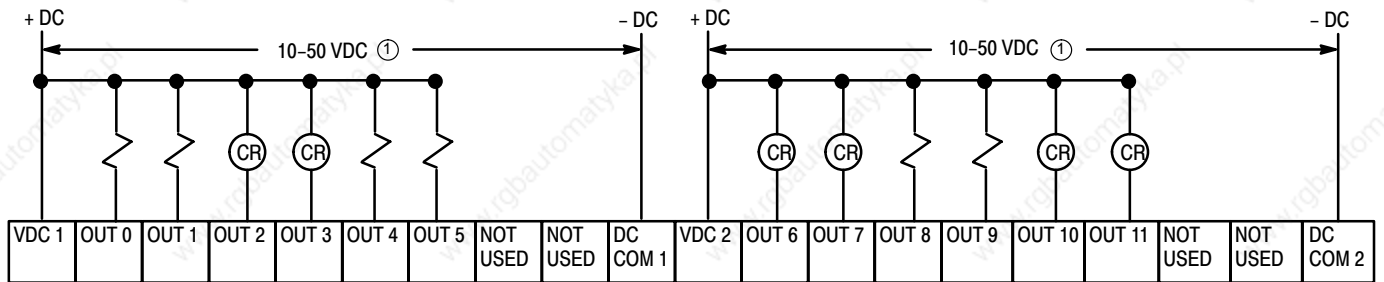

① The outputs are isolated in groups as shown. Therefore, different voltages can be applied to each group as the specific application requires.

② 24 VDC, 200mA user power is available for sensors.

Appendix E

Wiring and Circuit Diagrams and Voltage Ranges for Your Fixed Controller

Input Circuit Diagram

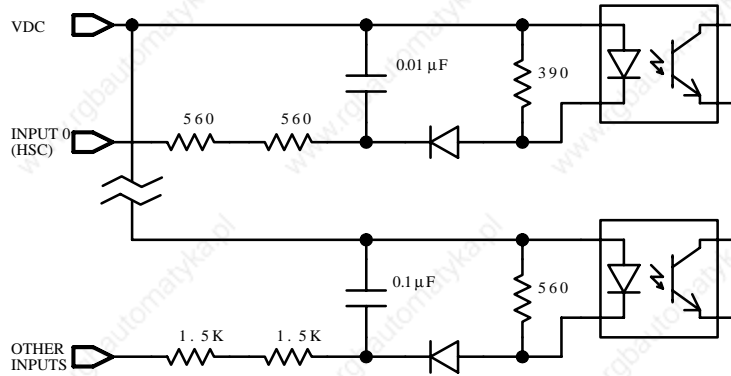

On/Off State Voltage Ranges – Input 0 (HSC)



On/Off State Voltage Ranges – All Other Inputs



Appendix E

Wiring and Circuit Diagrams and Voltage Ranges
for Your Fixed Controller

Output Circuit Diagram

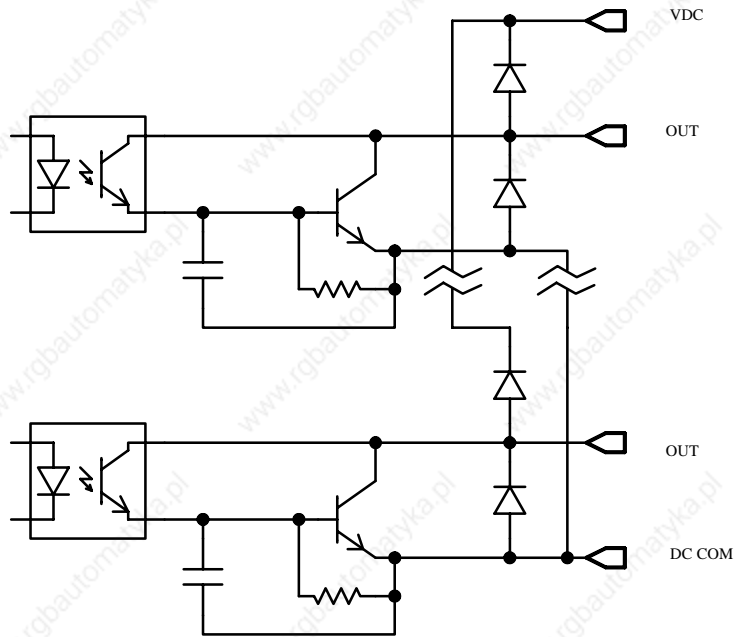

Operating Voltage Range

(Voltage is applied between +VDC
and DC common.)



Appendix E

Wiring and Circuit Diagrams and Voltage Ranges for Your Fixed Controller

Catalog Number 1747-L30P (18) 240 VAC Inputs & (12) Triac Outputs

Wiring Diagram

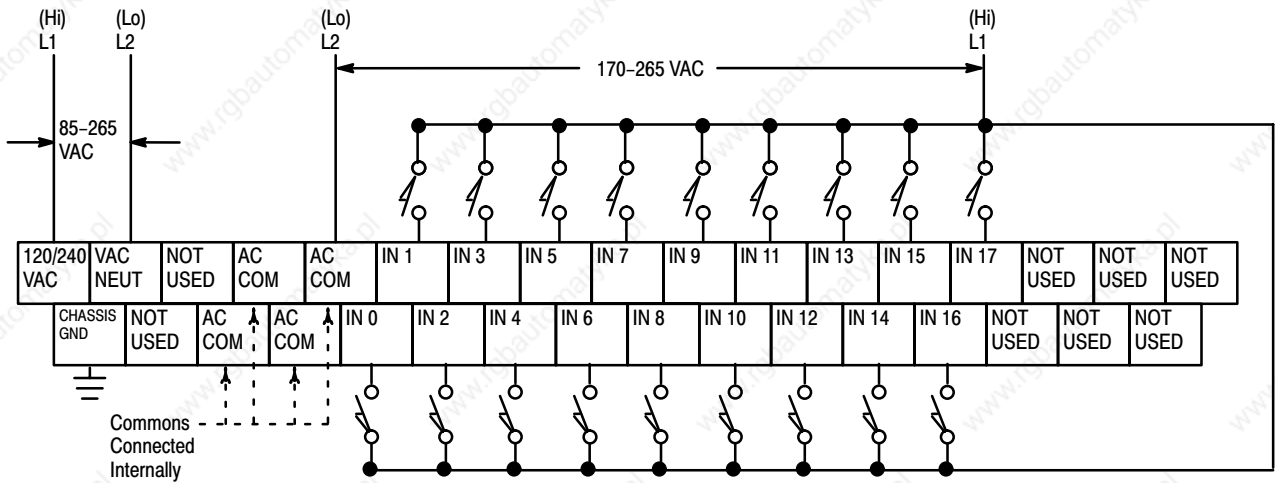
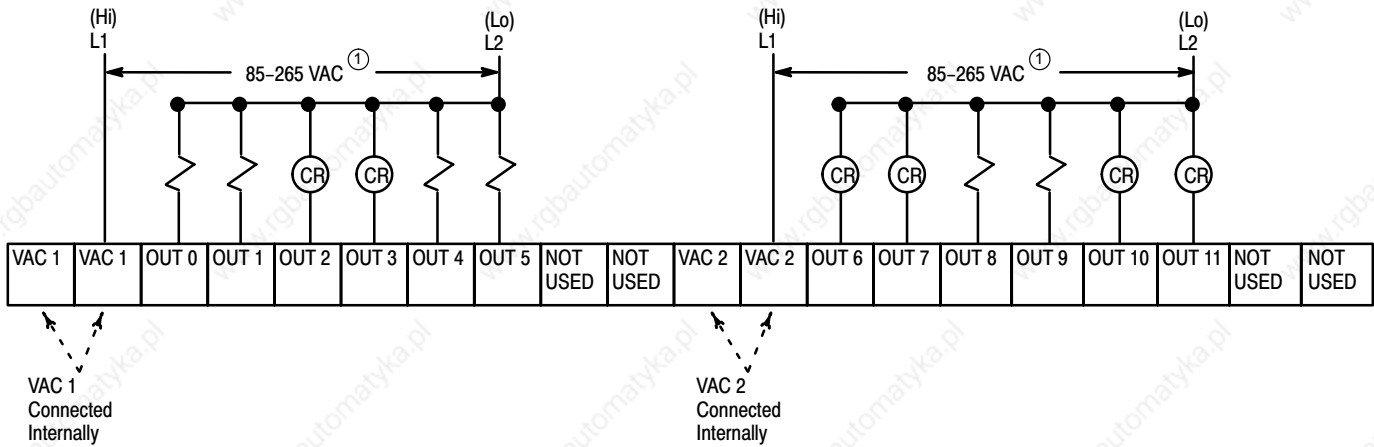

① The outputs are isolated in groups as shown. Therefore, different voltages can be applied to each group as the specific application requires.

Appendix E

Wiring and Circuit Diagrams and Voltage Ranges
for Your Fixed Controller

Input Circuit Diagram

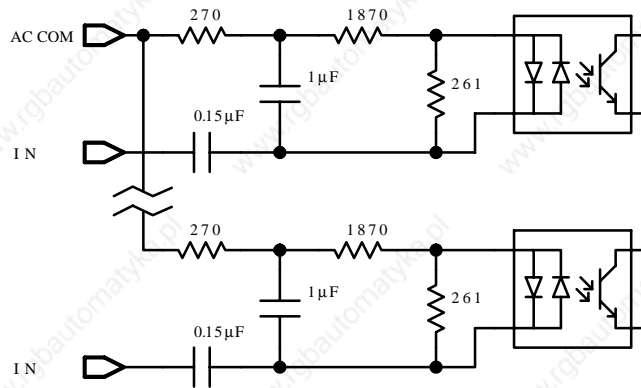

On/Off State Voltage Ranges



Output Circuit Diagram

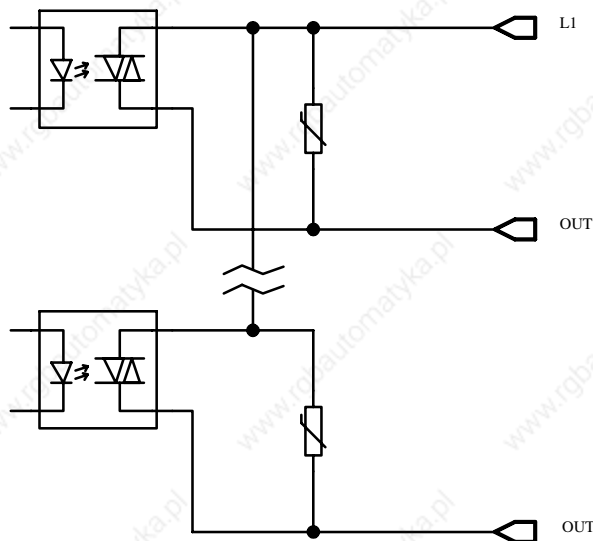

Operating Voltage Range

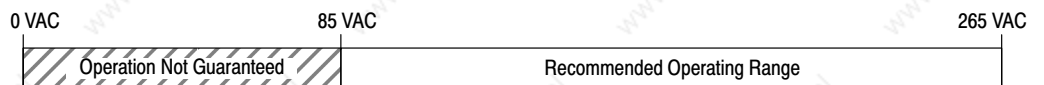

Important: If you measure the voltage at an output terminal that is not connected to a load or is connected to a high-impedance load, you may measure as much as 100 VAC even though the output is off.

Appendix E

Wiring and Circuit Diagrams and Voltage Ranges for Your Fixed Controller

Catalog Number 1747-L40A Wiring Diagram (24) 120 VAC Inputs & (16) Relay Outputs

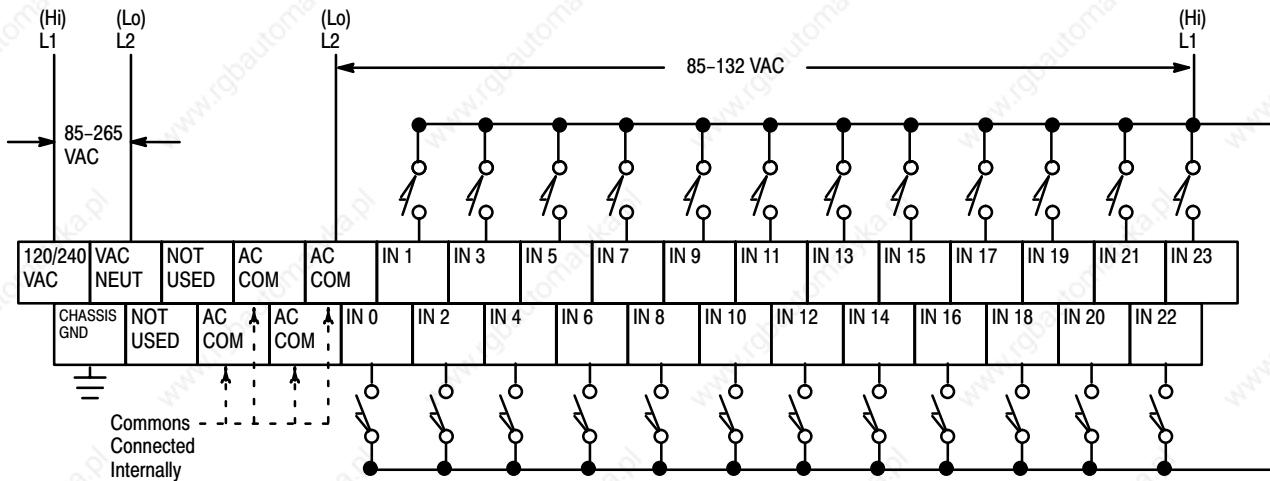
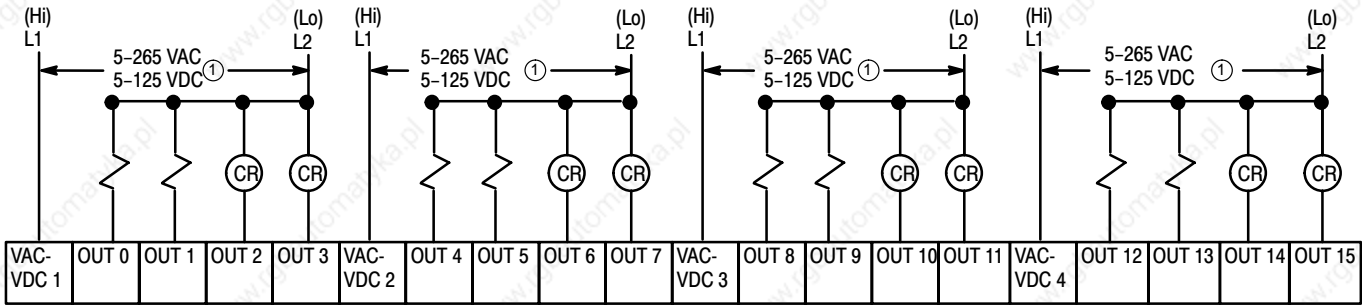

① The outputs are isolated in groups as shown. Therefore, different voltages can be applied to each group as the specific application requires.

Appendix E

Wiring and Circuit Diagrams and Voltage Ranges
for Your Fixed Controller

Input Circuit Diagram

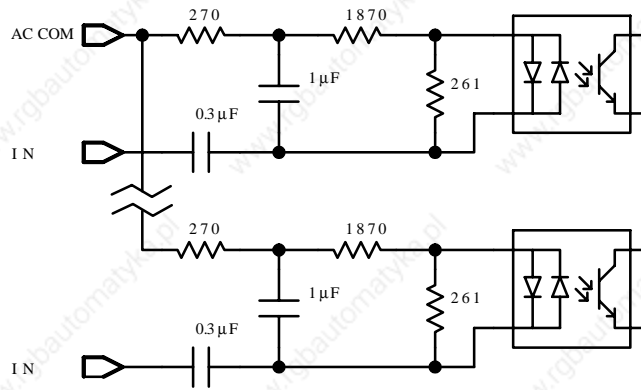

On/Off State Voltage Ranges

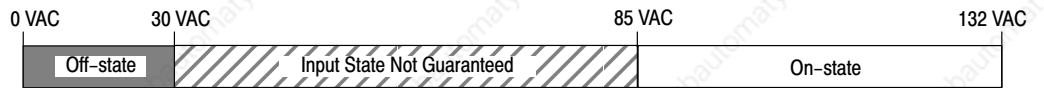

Output Circuit Diagram

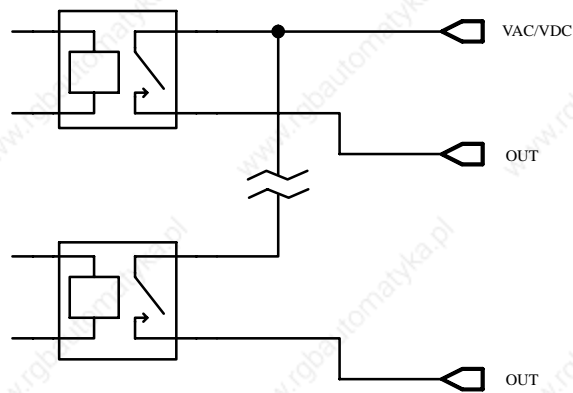

Operating Voltage Range

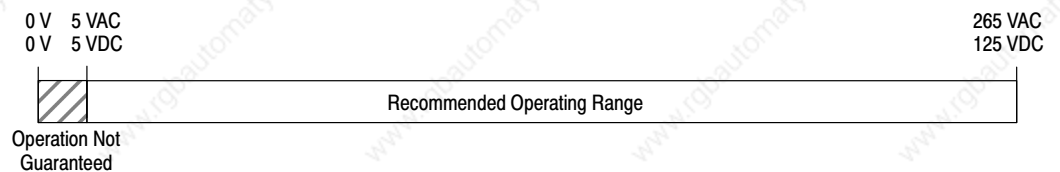

Appendix E

Wiring and Circuit Diagrams and Voltage Ranges for Your Fixed Controller

Catalog Number 1747-L40B Wiring Diagram (24) 120 VAC Inputs & (16) Triac Outputs

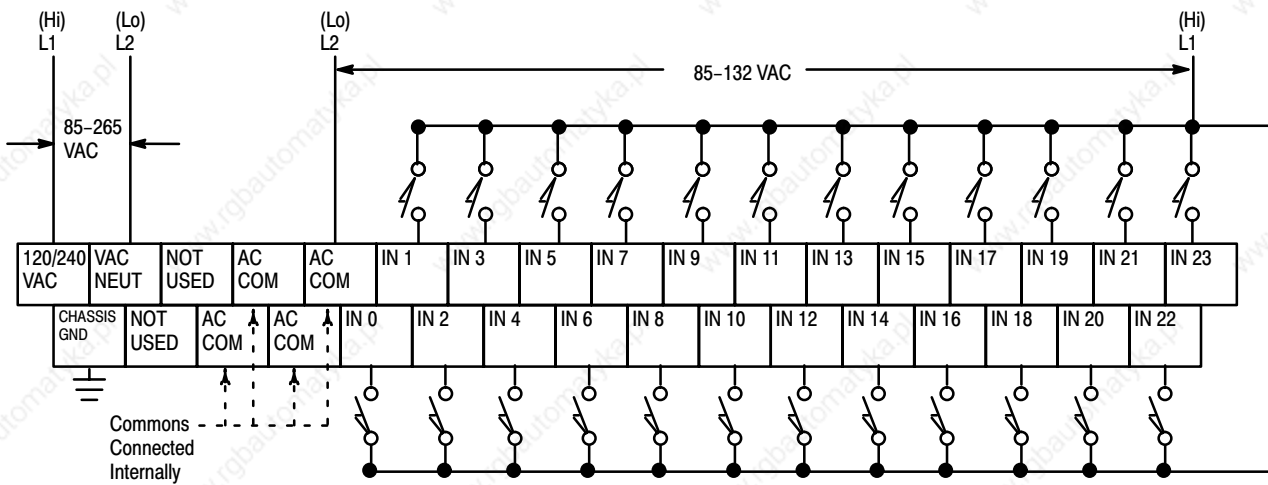
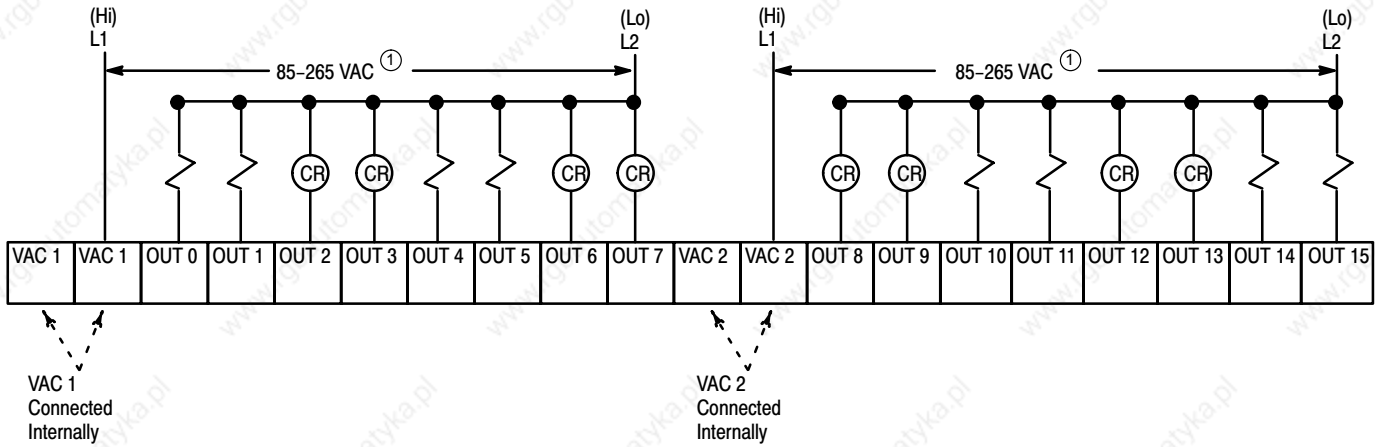

① The outputs are isolated in groups as shown. Therefore, different voltages can be applied to each group as the specific application requires.

Appendix E

Wiring and Circuit Diagrams and Voltage Ranges
for Your Fixed Controller

Input Circuit Diagram

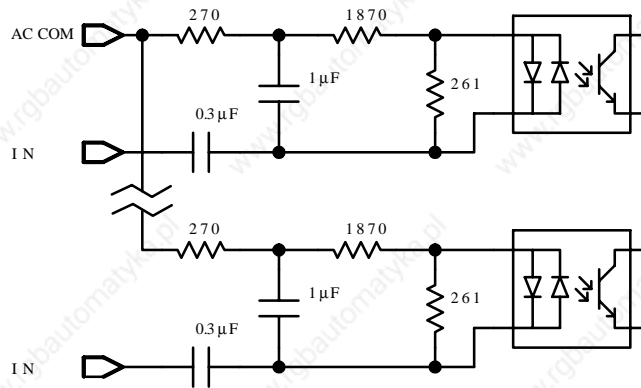

On/Off State Voltage Ranges

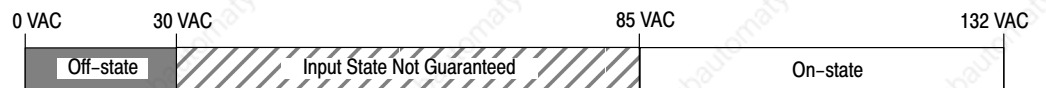

Output Circuit Diagram

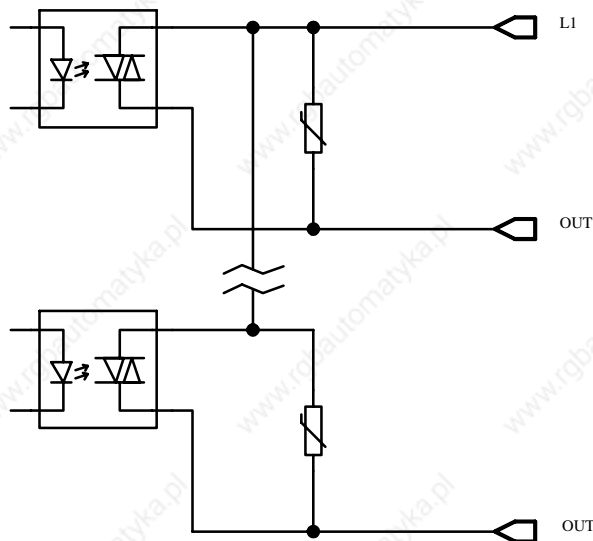

Operating Voltage Range

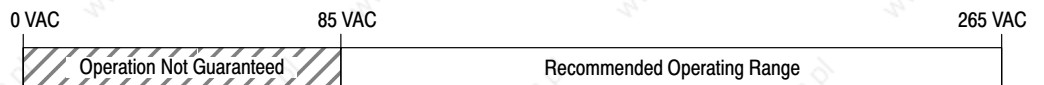

Important: If you measure the voltage at an output terminal that is not connected to a load or is connected to a high-impedance load, you may measure as much as 100 VAC even though the output is off.

Appendix E

Wiring and Circuit Diagrams and Voltage Ranges for Your Fixed Controller

Catalog Number 1747-L40C Wiring Diagram (24) 24 VDC Sinking Inputs, High-Speed Counter Input & (16) Relay Outputs

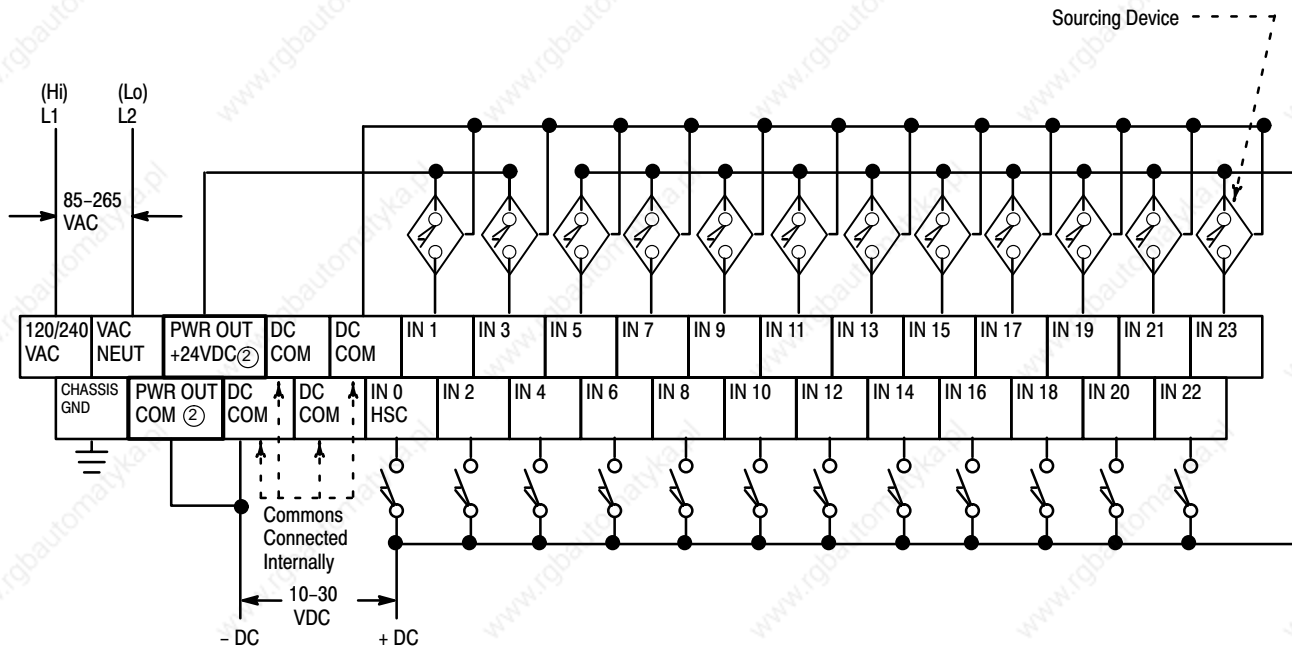
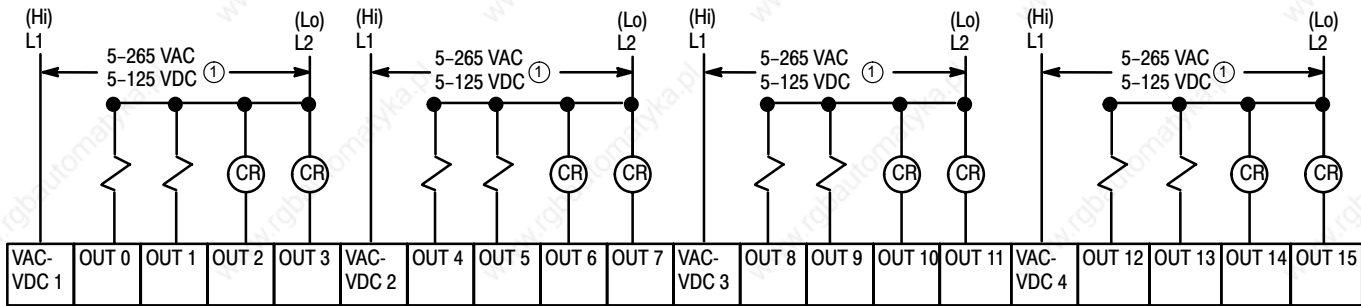

- ① The outputs are isolated in groups as shown. Therefore, different voltages can be applied to each group as the specific application requires.
- ② 24 VDC, 200mA user power is available for sensors.

Appendix E

Wiring and Circuit Diagrams and Voltage Ranges
for Your Fixed Controller

Input Circuit Diagram

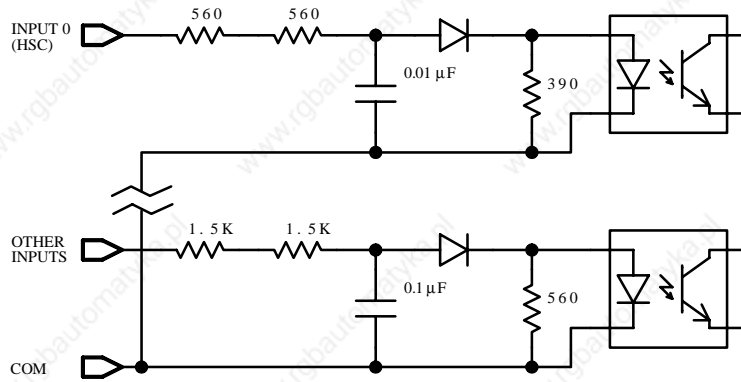

On/Off State Voltage Ranges – Input 0 (HSC)



On/Off State Voltage Ranges – All Other Inputs

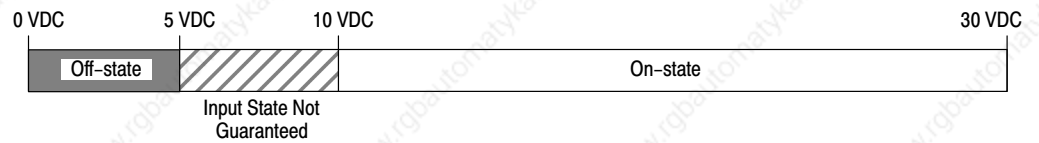

Appendix E

Wiring and Circuit Diagrams and Voltage Ranges for Your Fixed Controller

Output Circuit Diagram

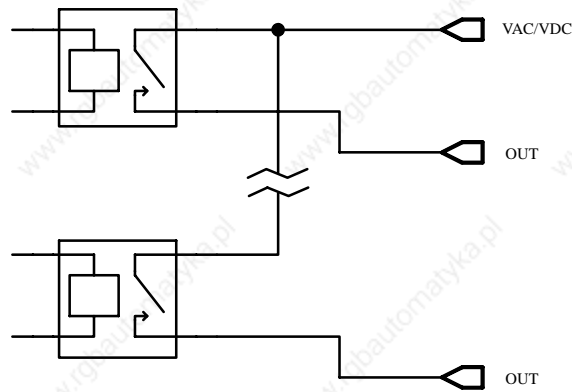

Operating Voltage Range

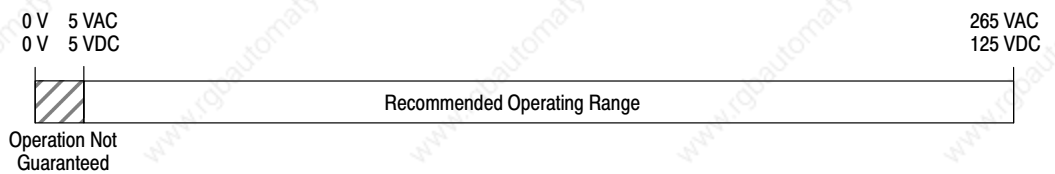

Catalog Number 1747-L40E **Wiring Diagram**
(24) 24 VDC Sinking Inputs,
High-Speed Counter Input &
(16) Transistor Sourcing
Outputs

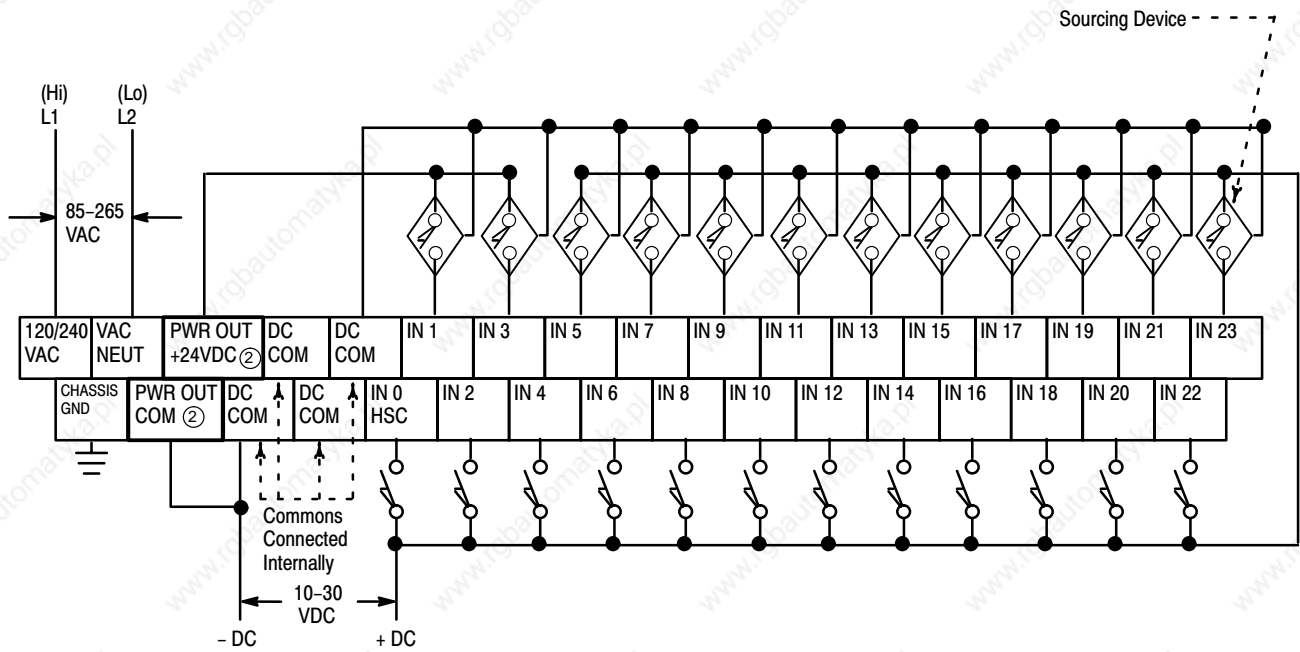
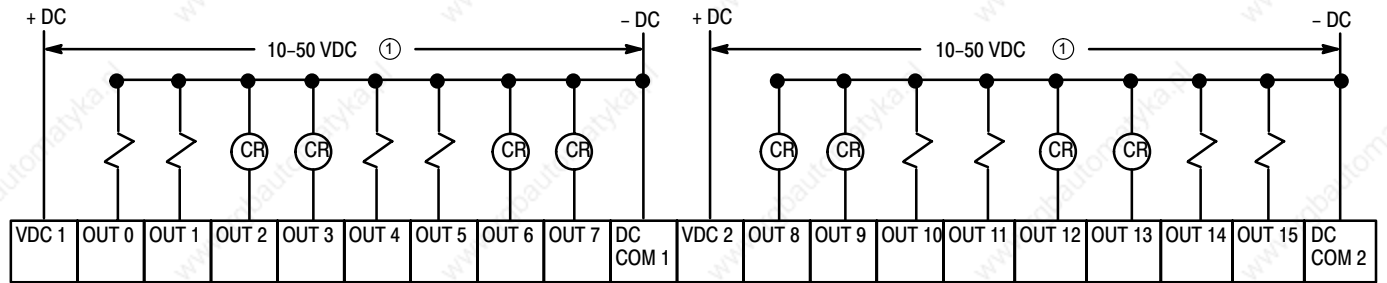

- ① The outputs are isolated in groups as shown. Therefore, different voltages can be applied to each group as the specific application requires.
- ② 24 VDC, 200mA user power is available for sensors.

Appendix E

Wiring and Circuit Diagrams and Voltage Ranges for Your Fixed Controller

Input Circuit Diagram

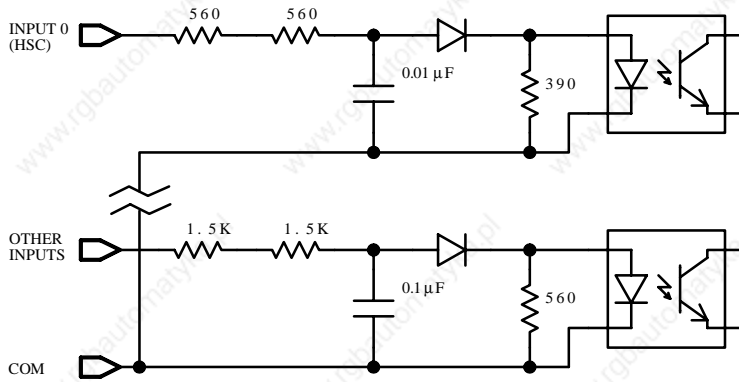

On/Off State Voltage Ranges – Input 0 (HSC)



On/Off State Voltage Ranges – All Other Inputs



Appendix E

Wiring and Circuit Diagrams and Voltage Ranges
for Your Fixed Controller

Output Circuit Diagram

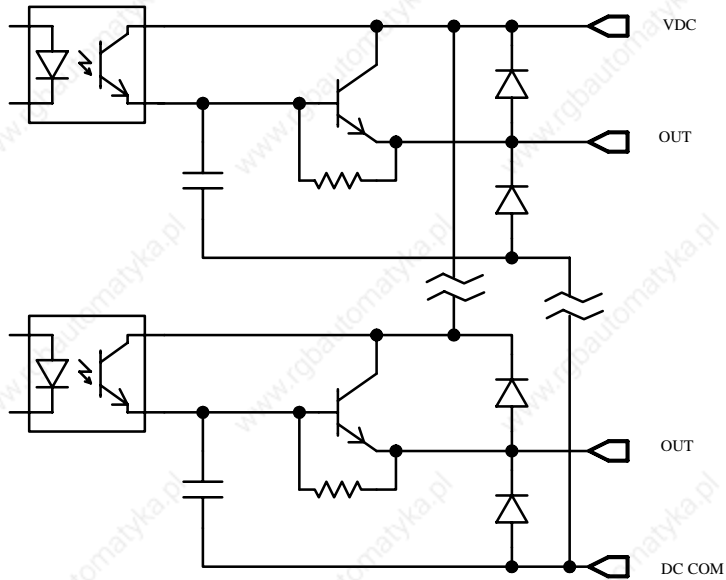

Operating Voltage Range

(Voltage is applied between +VDC
and DC common.)



Appendix E

Wiring and Circuit Diagrams and Voltage Ranges
for Your Fixed Controller

Catalog Number 1747-L40F (24) 24 VDC Sinking Inputs, High-Speed Counter Input & (16) Relay Outputs

Wiring Diagram

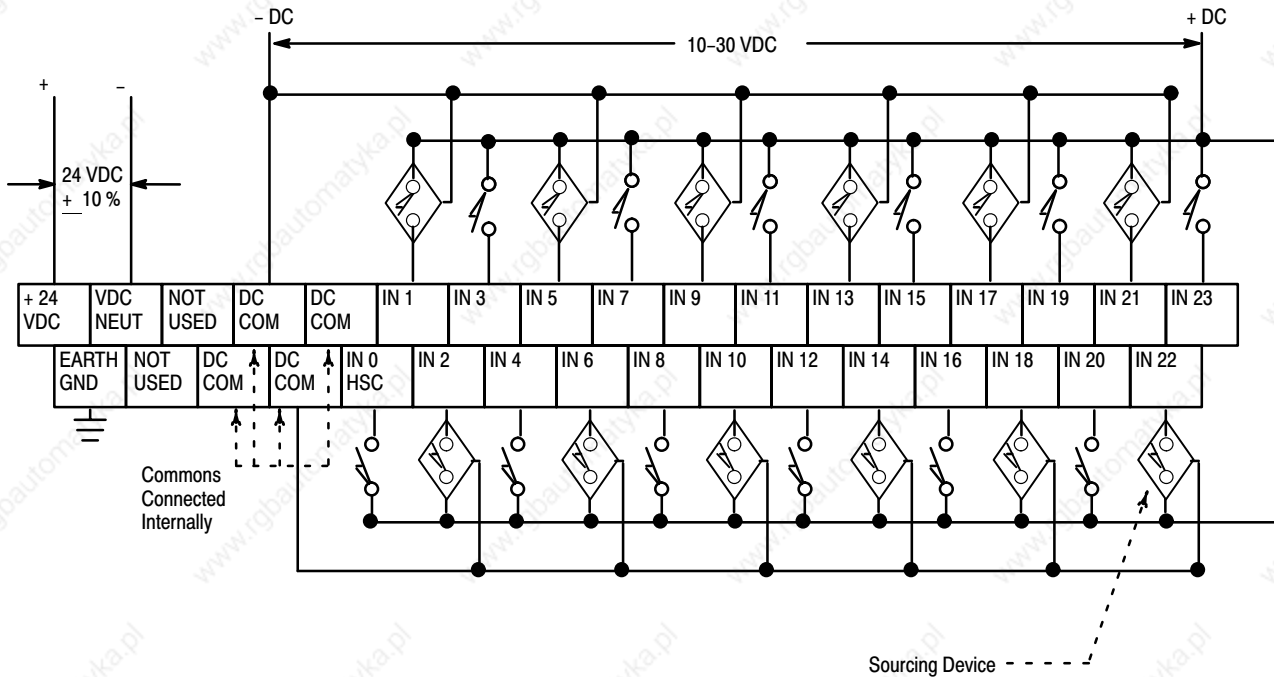
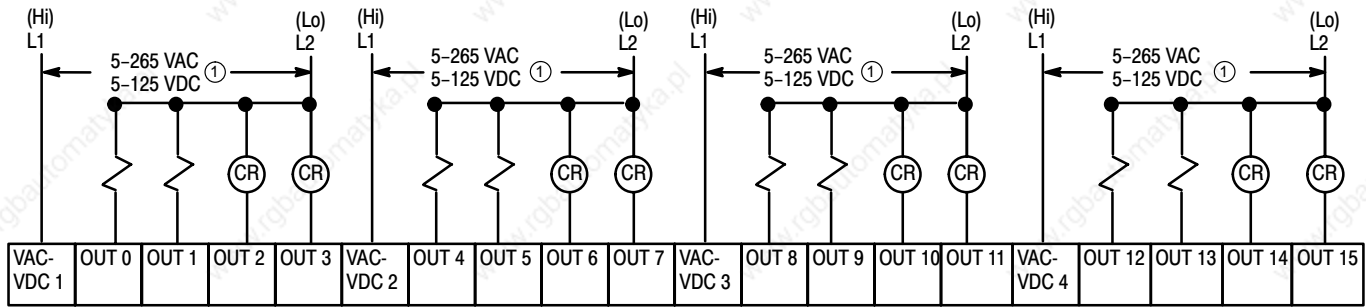

^① The outputs are isolated in groups as shown. Therefore, different voltages can be applied to each group as the specific application requires.

Appendix E

Wiring and Circuit Diagrams and Voltage Ranges
for Your Fixed Controller

Input Circuit Diagram

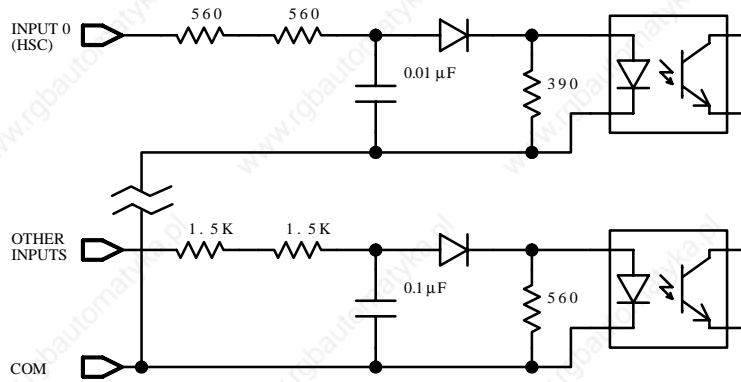

On/Off State Voltage Ranges – Input 0 (HSC)



On/Off State Voltage Ranges – All Other Inputs



Appendix E

Wiring and Circuit Diagrams and Voltage Ranges for Your Fixed Controller

Output Circuit Diagram

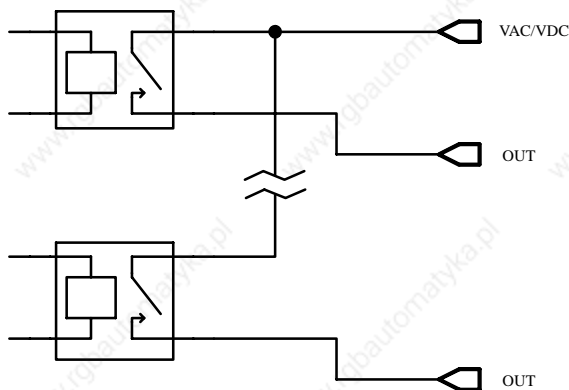

Operating Voltage Range

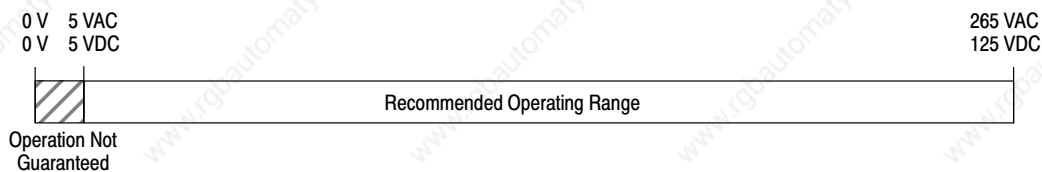

Catalog Number 1747-L40L **Wiring Diagram**
(24) 24 VDC Sourcing Inputs,
High-Speed Counter Input &
(16) Transistor Sinking
Outputs

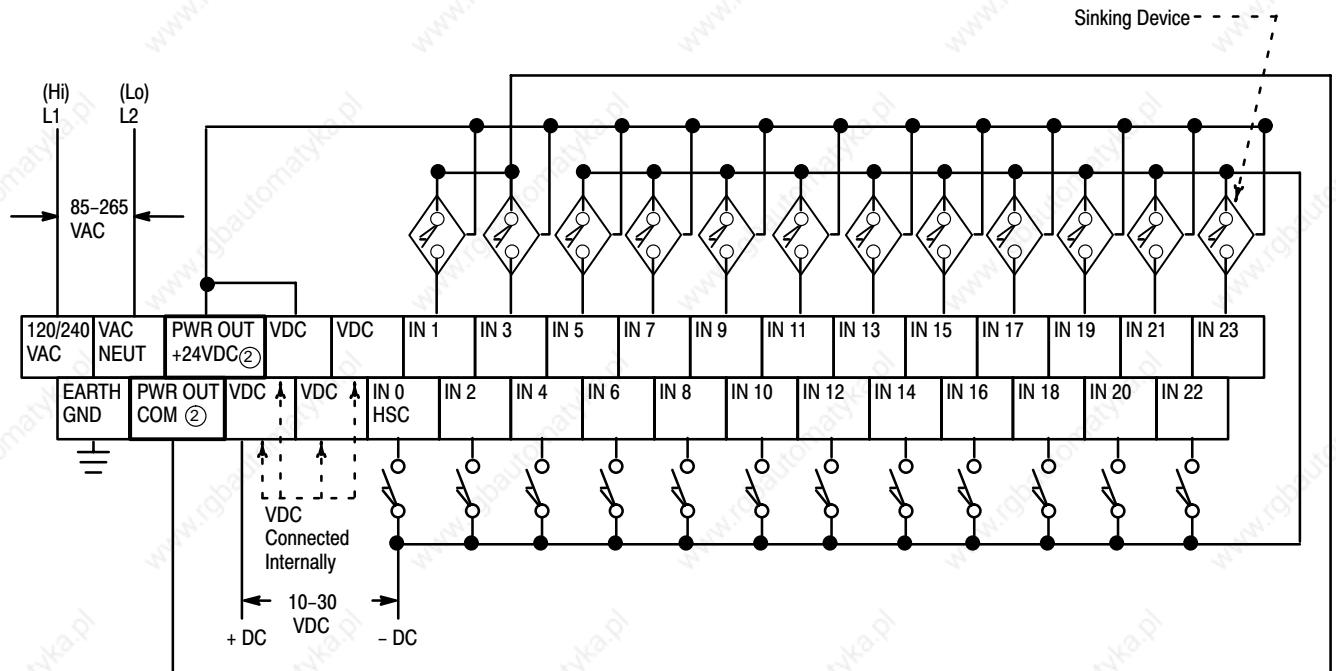
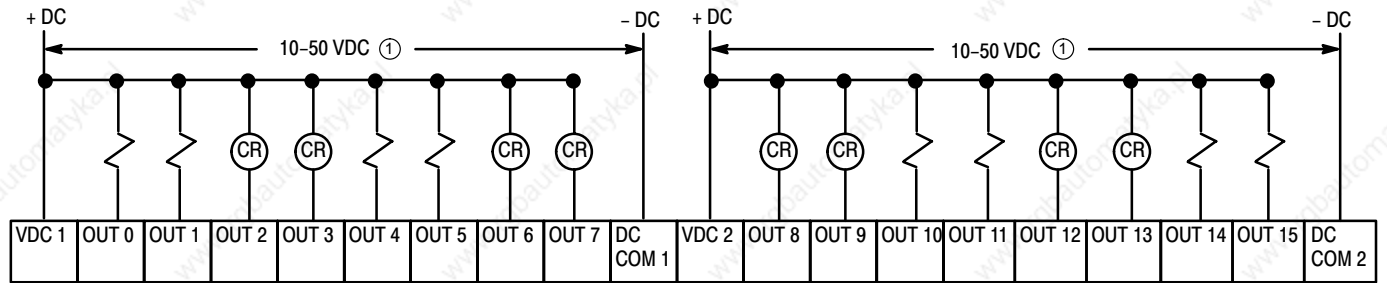

① The outputs are isolated in groups as shown. Therefore, different voltages can be applied to each group as the specific application requires.

② 24 VDC, 200mA user power is available for sensors.

Appendix E

Wiring and Circuit Diagrams and Voltage Ranges for Your Fixed Controller

Input Circuit Diagram

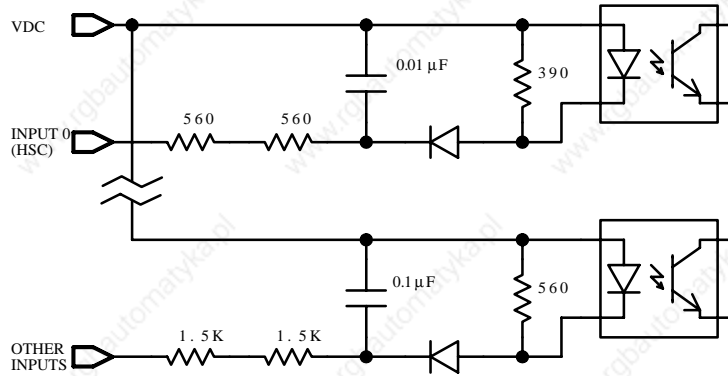

On/Off State Voltage Ranges – Input 0 (HSC)



On/Off State Voltage Ranges – All Other Inputs



Appendix E

Wiring and Circuit Diagrams and Voltage Ranges
for Your Fixed Controller

Output Circuit Diagram

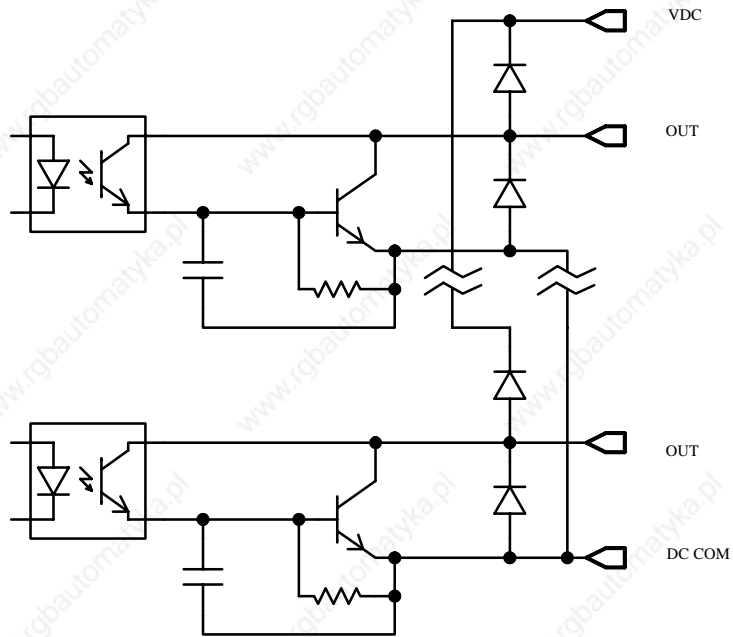

Operating Voltage Range

(Voltage is applied between +VDC
and DC common.)



Appendix E

Wiring and Circuit Diagrams and Voltage Ranges for Your Fixed Controller

Catalog Number 1747-L40P Wiring Diagram (24) 240 VAC Inputs & (16) Triac Outputs

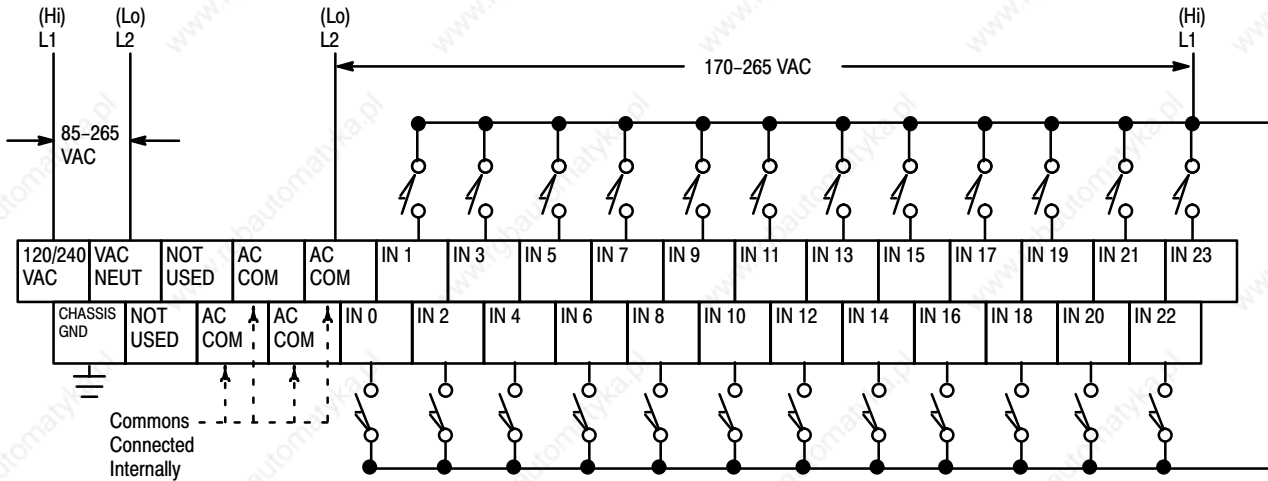
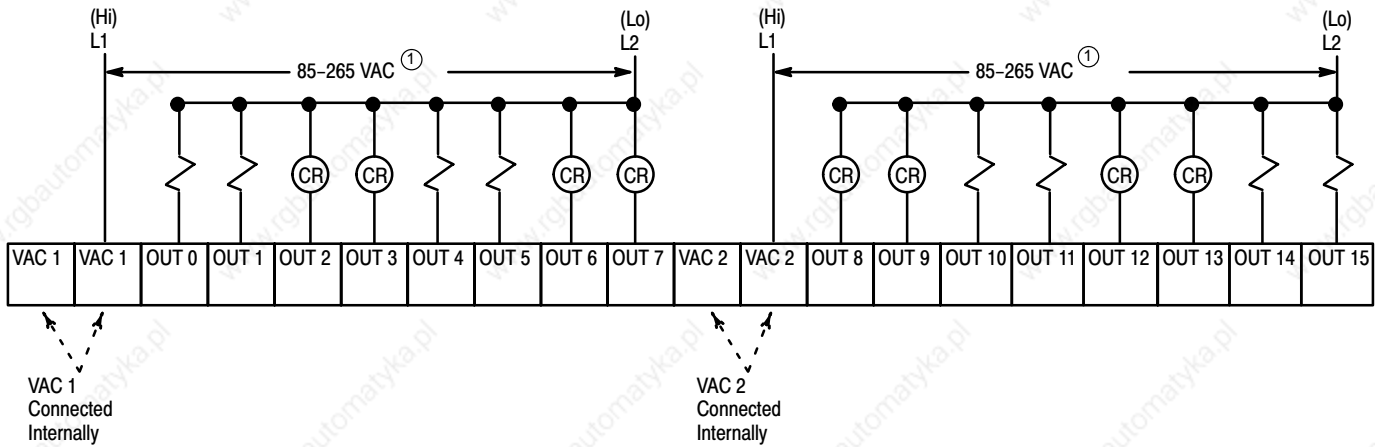

① The outputs are isolated in groups as shown. Therefore, different voltages can be applied to each group as the specific application requires.

Appendix E

Wiring and Circuit Diagrams and Voltage Ranges
for Your Fixed Controller

Input Circuit Diagram

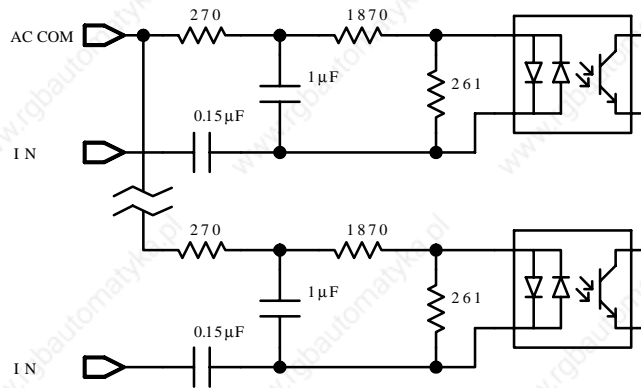

On/Off State Voltage Ranges



Output Circuit Diagram

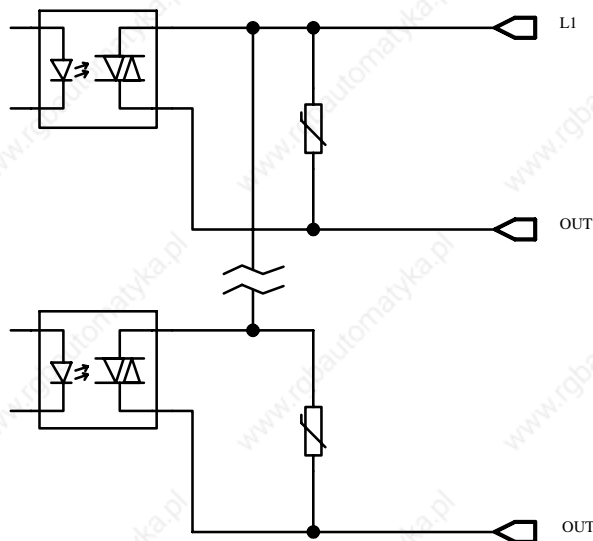

Operating Voltage Range

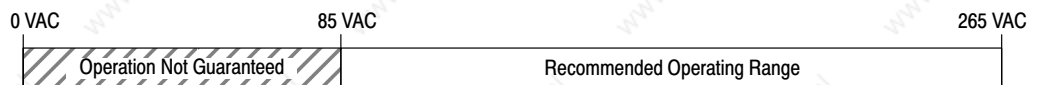

Important: If you measure the voltage at an output terminal that is not connected to a load or is connected to a high-impedance load, you may measure as much as 100 VAC even though the output is off.

Glossary

Auto Answer — The type of modem that has self-contained timeouts and tests. They can answer and hang the phone up automatically.

Backplane Current Draw — The amount of current the module requires from the backplane. The sum of the backplane current draw for all modules in a chassis is used to select the appropriate chassis power supply.

Baud Rate — The speed of communication between devices on a network. All devices must communicate at the same baud rate. For example, the DH-485 network devices default to 19,200 baud.

Calculated Watts — The amount of heat generated by those points energized on an I/O module.

Channel — Communication port on a module.

Chassis — A hardware assembly that houses devices such as I/O modules, adapter modules, processor modules, and power supplies.

Continuous Current Per Module — The maximum current for each module. The sum of the output current for each point should not exceed this value.

Continuous Current Per Point — The maximum current each output is designed to continuously supply to a load.

CPU — Central Processing Unit or processor.

DF1 protocol — A peer-to-peer link-layer protocol that combines features of ANSI X3.28-1976 specification subcategories D1 (data transparency) and F1 (two-way simultaneous transmission with embedded responses).

Direct Connect — A type of modem that is connected to a dedicated, leased phone line and is active at all times.

DH-485 Network — The DH-485 network is a collection of devices connected to the communication cable allowing information exchange. A communication network based on the EIA Standard for RS-485 using an Allen-Bradley proprietary protocol.

DTE Controlled Answer — type of modem that is unattended and is attached directly to the phone lines. The interface module or the 5/03 processor acts as the Data Terminal Equipment (DTE), which controls the modem via the DTR, DSR, and DCD signals. The module incorporates timeouts and tests to properly operate these types of modems.

DTR Dialing (5/03 only) — type of modem that lets you dial a number or end a call based on the status of the RS-232 DTR (Data Terminal Ready) signal. To program the modem initialization string and phone number into the internal memory of the modem, use a dumb terminal (or PC running terminal emulation software like Procomm, Window's Terminal, or PBASE). Once you have programmed the modem, activate the DTR signal to dial the number, or deactivate the DTR signal to end the call.

EEPROM — Electrically Erasable Programmable Read Only Memory module used to store, back up, or transfer SLC 500 programs. The SLC 500 can read and write to an EEPROM.

Flash EPROM — Flash Erasable Programmable Read Only Memory module. It combines the programming versatility of EEPROMs with the security precautions of UVEPROMs. This means that you have the option of leaving your EPROM programs write protected or unprotected.

Full-duplex — A high performance protocol that allows simultaneous two-way data transmission. For point-to-point applications only.

Half-duplex — A high performance protocol that can be used in point-to-point and multi-point applications.

Initiator — A node on the DH-485 network capable of acting as a master. When an initiator has the token it can send messages and request replies from any node on the DH-485 network. A personal computer running the SLC 500 Advanced Programming Software is an initiator on the data link. The SLC 5/02 can also be an initiator.

Input Device — A device, such as a push button or a switch, that supplies signals through input circuits to a programmable controller.

Inrush Current — The temporary surge current produced when a device or circuit is initially energized.

I/O — Inputs and Outputs

Isolated Link Coupler — The link coupler provides an electrically isolated network connection for an SLC 500 controller (processor or programming station). The link couplers connect the daisy-chained DH-485 communication cable.

LED — Light Emitting Diode. Used as status indicator for processor functions and inputs and outputs.

Manual — typically an acoustically coupled type of modem. The connection is established by a person on each end of the phone line. They then insert the handsets into an acoustic coupler to complete the connection.

Maximum Watts — The maximum amount of heat that the module generates with field power present.

Minimum Load Current — The lowest amount of current the output is designed to operate at. Operating at or below this value is not reliable.

Minimum Watts — The amount of heat dissipation that can occur when there is no field power present.

Multi-master network — A network in which more than one node has the ability to initiate communications and initialize the link.

Network — A series of stations (nodes) connected by some type of communication medium. A network may be made up of a single link or multiple links.

Node — Also called a station. An address or software location on the network.

Nominal Input Current — The current at nominal input voltage.

Off-State Current — For input circuits, the maximum amount of leakage current allowed from an input device in its Off-state.

Off-State Leakage — For output circuits, the maximum amount of (leakage) current that may flow when the output circuit is in its Off-state.

Off-State Voltage (max) — The maximum input voltage level detected as an Off condition by the input module.

On-State Voltage Drop — The voltage developed across the output driver circuit during the On state at maximum load current.

Operating Voltage — For inputs, the voltage range needed for the input to be in the On state. For outputs, the allowable range of user-supplied voltage.

Output Device — A device, such as a pilot light or a motor starter coil, that is energized by the programmable controller.

Points per Common — The number of input or output points connected to a single return (common) or supply (vcc).

Protocol — The “language” or packaging of information that is transmitted across a network.

(I/O) Rack — An I/O addressing unit that corresponds to 8 input image-table words and 8 output image-table words. A rack can contain a maximum of 8 I/O groups for up to 128 discrete I/O.

Remote I/O Network — A network where the communication between the processor and the I/O is across a serial link.

Responder — A node on the DH-485 network that acts as a slave device. A responder is not capable of initiating communications. It can only send messages in response to a request from an initiator. The SLC 5/01 and 5/02 can also be responders.

RS-232 — An EIA standard that specifies electrical, mechanical, and functional characteristics for serial binary communication circuits. A single-ended serial communication interface.

RTB —Removable Terminal Block.

Signal Delay — For inputs, the response time required to transmit the circuit status from the field wiring to the digital logic. For outputs, the time required to transmit the circuit status from digital logic to the output wiring.

Sinking — A term used to describe current flow between an I/O device and SLC I/O circuit — typically, a sinking device or circuit provides a path to ground, low, or negative side of power supply.

Sinking/Sourcing — Describes a current signal flow relationship between field input and output devices in a control system and their power supply. Sourcing I/O modules supply (or source) current to sinking field devices. Sinking I/O modules receive (or sink) current from sourcing field devices.

Sourcing — A term used to describe current flow between an I/O device and SLC I/O circuit — typically, a sourcing device or circuit provides a path to the source, high, or positive side of power supply.

Surge Current Per Point — The maximum amplitude and duration (pulse) of current allowed for a given period of time and temperature.

Surge Suppressor — A device used to absorb voltage transients created by energizing an inductive load to reduce electrical noise or to protect the output circuit. For example, an R–C network, MOV (metal oxide varistor) or diode.

Token — The logical right to initiate communications. In a multi–master network a single token is passed between initiators to make sure two nodes do not transmit at the same time.

UVPRM — An Ultra–Violet light erasable Programmable Read Only Memory module used to back up, store, or transfer SLC 500 programs. The SLC 5/01 and 5/02 can only read from a UVPRM. An external PROM programmer is used to program (write to) the device.

Voltage Category — The nominal voltage used to describe the module.

Watts Per Point — The maximum heat dissipation that can occur in each field wiring point when energized.

Numbers

1746-2.35, publication number, [5-7](#)
1746-BAS module, [A-3](#), [C-2](#)
1746-ND005, manual catalog number,
[A-3](#), [C-2](#)
1746-NM001, manual catalog number,
[A-3](#)
1746-NM002, manual catalog number,
[A-3](#)
1747-2.30, publication number, [1-1](#)
1747-AIC link coupler, [A-4](#)
1747-BA, lithium battery
assembly, [9-1](#)
handling, [7-1](#)
installing, [7-4](#)
memory backup, [1-4](#)
replacing, [7-4](#)
storing, [7-1](#)
transporting, [7-2](#)
1747-C10 cable, [A-4](#)
1747-C11 cable, [A-4](#)
1747-KE module, [A-3](#)
as an RS-232 communication device,
[C-2](#)
1747-NU001, manual catalog number,
[A-3](#), [C-2](#)
1770-4.1, publication number, [2-3](#)
1770-6.5.18, manual catalog number, [C-2](#)
1770-6.5.18, publication number, [A-3](#)
1770-KF3 module, [A-3](#), [C-2](#)
1771-Remote I/O Network, [B-1](#)
1784-2.23, publication number, [A-3](#)
1784-KR module, [A-3](#)
1785-1.21, publication number, [A-3](#)
1785-6.5.5, publication number, [A-3](#)
1785-KA5 module, [A-3](#)
1K User Words EEPROM
definition, [G-2](#)
installing, [4-4](#)
overview, [1-11](#)
replacement part, [9-1](#)
1K User Words UVPRM
definition, [G-4](#)
installing, [4-4](#)
overview, [1-11](#)
replacement part, [9-1](#)

2-Slot Expansion Chassis
dimensions, [3-4](#)
mounting, [4-1](#)
selecting, [1-8](#)
20 I/O Fixed Controller
Configuration Options, [1-5](#)
dimensions, [3-2](#)
general specifications, [1-3](#)
high-speed counter setup, [4-5](#)
Input Specifications, [1-6](#)
installation, [2-1](#)
memory module installation, [4-4](#)
Output Specifications, [1-7](#)
selecting the 2-slot expansion chassis,
[1-8](#)
Troubleshooting, [8-1](#)
Wiring and Circuit Diagrams and Voltage
Range Locations, [E-2](#)
2760-ND001, publication number, [A-3](#)
2760-RB module, [A-3](#)
30 and 40 I/O Fixed Controller
Configuration Options, [1-5](#)
dimensions, [3-3](#)
general specifications, [1-3](#)
high-speed counter setup, [4-5](#)
Input Specifications, [1-6](#)
installation, [2-1](#)
memory module installation, [4-4](#)
Output Specifications, [1-7](#)
selecting the 2-slot expansion chassis,
[1-8](#)
Troubleshooting, [8-1](#)
Wiring and Circuit Diagrams and Voltage
Range Locations, [E-2](#)
4K User Words EEPROM
definition, [G-2](#)
installing, [4-4](#)
overview, [1-11](#)
4K User Words UVPRM
definition, [G-4](#)
overview, [1-11](#)
6001-6.5.5, publication number, [A-3](#)

A

Adaptor Socket, [1-11](#)
Advanced Programming Software,
1747-PA2E
overview, [1-10](#)
using, [6-3](#)

Allen-Bradley, contacting for assistance, [P-4](#), [8-1](#)

Article 70B of the NFPA, [2-9](#)

B

BASIC programming language, [C-2](#)

Belden #9842

connecting to link coupler, [A-11](#)

new wire/terminal connections, [A-12](#)

old wire/terminal connections, [A-12](#)

overview, [A-9](#)

C

cable routes, planning, [A-6](#)

cables

1747-C10, [A-4](#)

1747-C11, [A-4](#)

Belden #9842, [A-9](#), [A-11](#), [A-12](#)

calculated watts

definition, [G-1](#)

overview, [D-1](#)

circuit operation

input, [8-8](#)

output, [8-10](#)

Common Power Source, [2-7](#)

communication interface, RS-232, [C-1](#)

Configuration Options, [1-5](#)

contact protection

diodes, [1-16](#)

RC network, [1-16](#)

reducing high transient arcing, [1-16](#)

surge suppressor, [1-16](#)

varistor, [1-16](#)

contacting Allen-Bradley for assistance,

[P-4](#), [8-1](#)

CPU fault, [8-5](#)

CPU major error with low or no battery

back-up, [8-7](#)

CPU major fault, [8-6](#)

D

DCE Pinout, [C-4](#)

DH-485, token rotation, [A-2](#)

DH-485 Communication Interface user's manual, [C-2](#)

DH-485 interface converter, [1-10](#)

DH-485 network

description, [A-1](#), [G-1](#)

devices that use the, [A-3](#)

example system configuration, [A-5](#)

grounding and terminating, [A-13](#)

initialization, [A-2](#)

installation, [A-9](#)

isolated link coupler, [A-4](#)

protocol, [A-1](#)

token rotation, [A-2](#)

DH-485/RS-232 Interface Module user's manual, [C-2](#)

diode, 1N4004, [1-16](#)

discrete I/O modules

features, [5-5](#)

installing, [4-2](#)

replacing retainer clips, [7-6](#)

selecting, [1-8](#)

troubleshooting, [8-8](#), [8-10](#)

wiring, [5-7](#)

documents referenced in this manual

1746-2.35, publication number, [5-7](#)

1746-ND005, catalog number, [A-3](#)

1746-NM001, catalog number, [A-3](#)

1746-NM002, catalog number, [A-3](#)

1747-2.30, publication number, [1-1](#)

1747-NU001, catalog number, [A-3](#)

1770-4.1, publication number, [2-3](#)

1770-6.5.18, publication number, [A-3](#)

1784-2.23, publication number, [A-3](#)

1785-1.21, publication number, [A-3](#)

1785-6.5.5, publication number, [A-3](#)

2760-RB module, publication number, [A-3](#)

6001-6.5.5, publication number, [A-3](#)

DTAM

dimensions, [3-5](#)

monitoring with, [1-10](#)

DTE

controlled answer, [G-1](#)

pinout, [C-4](#)

DTR dialing, [G-2](#)

E

EEPROM memory module

definition, [G-2](#)

installing, [4-4](#)

overview, [1-11](#)

replacement part, [9-1](#)

Electronics Industries Association (EIA), [C-1](#)

Emergency-Stop Switches, [2-6](#)

enclosures

grounding, [2-3](#)

selecting, [1-9](#)

spacing within, [2-2](#)

errors, [8-4](#)

Excessive Line Voltage Variations, [1-13](#)

Excessive Noise, [1-13](#)

F

fuse replacement, [7-5](#), [8-3](#), [9-1](#)

G

ground bus, [2-4](#)

grounding guidelines, [2-3](#)

H

Hand-Held Terminal, programming with, [1-9](#)

heat dissipation

for control system, [D-1](#)

from enclosures, [2-2](#)

worksheet for calculating, [D-5](#)

High-Speed Counter

configurable controllers, [1-5](#)

input compatibility, [4-6](#)

operation, [4-5](#)

sinking input circuit diagram, [4-7](#)

sourcing input circuit diagram, [4-7](#)

How to Use this Manual, [P-2](#)

I

I/O modules, wiring, [5-7](#)

IBM AT connector pin assignment, [C-6](#)

IBM compatible computer, programming with, [1-9](#)

ICCG-11.6, publication number, [C-1](#)

inadequate system power, [8-4](#)

input circuit diagrams

1747-L20A (12) 120 VAC inputs & (8) relay outputs, [E-5](#)

1747-L20B (12) 120 VAC inputs & (8) triac outputs, [E-7](#)

1747-L20C (12) 24 VDC sinking inputs, high-speed counter input & (8) relay outputs, [E-9](#)

1747-L20D (12) 24 VDC sinking inputs, high-speed counter input & (8) triac outputs, [E-12](#)

1747-L20E (12) 24 VDC sinking inputs, high-speed counter input & (8) transistor sourcing outputs, [E-15](#)

1747-L20F (12) 24 VDC sinking inputs, high-speed counter input & (8) relay outputs, [E-18](#)

1747-L20G (12) 24 VDC sinking inputs, high-speed counter input & (8) transistor sourcing outputs, [E-21](#)

1747-L20L (12) 24 VDC sourcing inputs, high-speed counter input & (8) transistor sinking outputs, [E-24](#)

1747-L20N (12) 24 VDC sourcing inputs, high-speed counter input & (8) transistor sinking outputs, [E-27](#)

1747-L20P (12) 24 VAC inputs & (8) triac outputs, [E-30](#)

1747-L20R (12) 240 VAC inputs & (8) relay outputs, [E-32](#)

1747-L30A (18) 120 VAC inputs & (12) relay outputs, [E-34](#)

1747-L30B (18) 120 VAC inputs & (12) triac outputs, [E-36](#)

1747-L30C (18) 24 VDC sinking inputs, high-speed counter input & (12) relay outputs, [E-38](#)

1747-L30D (18) 24 VDC sinking inputs, high-speed counter input & (12) triac outputs, [E-41](#)

1747-L30L (18) 24 VDC sourcing inputs, high-speed counter input & (12) transistor outputs, [E-44](#)

1747-L30P (18) 240 VDC inputs & (12) triac outputs, [E-47](#)

1747-L40A (24) 120 VAC inputs & (16) relay outputs, [E-49](#)

1747-L40B (24) 120 VAC inputs & (16) triac outputs, [E-51](#)

1747-L40C (24) 24 VDC sinking inputs, high-speed counter input & (16) relay outputs, [E-53](#)

1747-L40E (24) 24 VDC sinking inputs, high-speed counter input & (16) transistor sourcing outputs, [E-56](#)

1747-L40F (24) 24 VDC sinking inputs, high-speed counter input & (16) relay outputs, [E-59](#)

1747-L40L (24) 24 VDC sourcing inputs, high-speed counter input & (16) transistor sinking outputs, [E-62](#)

1747-L40P (24) 240 VAC inputs (16) triac outputs, [E-65](#)

Input Circuit Operation, [8-8](#)

input modules, troubleshooting, [8-8](#)

Input Specifications, [1-6](#)
 Input States on Power Down, [2-7](#)
 installation
 2-slot expansion chassis, [4-1](#)
 control system, [2-1](#)
 I/O and speciality modules, [4-2](#)
 lithium battery, [7-4](#)
 memory module, [4-4](#)
 interface converter (1747-PIC), [1-10](#)
 isolated link coupler
 definition, [G-2](#)
 installing, [A-16](#)
 overview, [A-4](#)
 powering, [A-14](#)
 isolation transformers, [1-12](#)

L

LEDs
 BATTERY LOW, [1-3](#), [8-3](#)
 CPU FAULT, [1-3](#), [8-3](#)
 FORCED I/O, [1-3](#), [8-3](#)
 PC RUN, [1-3](#), [8-3](#)
 POWER, [1-3](#), [8-3](#)
 link coupler
 definition, [G-2](#)
 installing, [A-16](#)
 overview, [A-4](#)
 powering, [A-14](#)
 lithium battery
 assembly, [9-1](#)
 handling, [7-1](#)
 installing, [7-4](#)
 memory backup, [1-4](#)
 replacing, [7-4](#)
 storing, [7-1](#)
 transporting, [7-2](#)
 Loss of Power Source, [2-7](#)

M

machine motion, preventing, [6-2](#)
 maintenance, preventive, [2-9](#)
 master control relay, [2-5](#)
 mating connector for 32 point user-made
 cable, [9-1](#)
 maximum watts
 definition, [G-2](#)
 overview, [D-1](#)
 memory modules
 1K User Words EEPROM, [1-11](#), [4-4](#),
 [G-2](#)

1K User Words UVPROM, [1-11](#), [4-4](#),
 [G-4](#)
 4K User Words EEPROM, [1-11](#), [4-4](#),
 [G-2](#)
 4K User Words UVPROM, [1-11](#), [G-4](#)
 minimum watts, [D-1](#), [G-3](#)
 modem
 auto answer, [G-1](#)
 direct connect, [G-1](#)
 manual, [G-2](#)
 modules
 discrete, [1-8](#), [4-2](#), [5-5](#), [5-7](#), [7-6](#),
 [8-8](#), [8-10](#)
 memory, [1-11](#), [4-4](#), [9-1](#), [G-2](#),
 [G-4](#)
 specialty, [1-8](#), [4-2](#), [5-5](#), [7-6](#)
 mounting
 2-slot expansion chassis, [3-4](#), [4-1](#)
 Data Table Access Module (DTAM), [3-5](#)
 fixed hardware units, [3-1](#)
 link coupler (AIC), [3-5](#)

O

on/off state voltages
 1747-L20A (12) 120 VAC inputs & (8)
 relay outputs, [E-5](#)
 1747-L20B (12) 120 VAC inputs & (8)
 triac outputs, [E-7](#)
 1747-L20C (12) 24 VDC sinking inputs,
 high-speed counter input & (8) relay
 outputs, [E-9](#)
 1747-L20D 12 (24) VDC sinking inputs,
 high-speed counter input & (8) triac
 outputs, [E-12](#)
 1747-L20E (12) 24 VDC sinking inputs,
 high-speed counter input & (8)
 transistor sourcing outputs, [E-15](#)
 1747-L20F (12) 24 VDC sinking inputs,
 high-speed counter input & (8) relay
 outputs, [E-18](#)
 1747-L20G (12) 24 VDC sinking inputs,
 high-speed counter input & (8)
 transistor sourcing outputs, [E-21](#)
 1747-L20L (12) 24 VDC sourcing inputs,
 high-speed counter input & (8)
 transistor sinking outputs, [E-24](#)
 1747-L20N (12) 24 VDC sourcing inputs,
 high-speed counter input & (8)
 transistor sinking outputs, [E-27](#)
 1747-L20P (12) 24 VAC inputs & (8) triac
 outputs, [E-30](#)
 1747-L20R (12) 240 VAC inputs & (8)
 relay outputs, [E-32](#)
 1747-L30A (18) 120 VAC inputs & (12)
 relay outputs, [E-34](#)

- 1747-L30B (18) 120 VAC inputs & (12) triac outputs, [E-36](#)
- 1747-L30C (18) 24 VDC sinking inputs, high-speed counter input & (12) relay outputs, [E-38](#)
- 1747-L30D (18) 24 VDC sinking inputs, high-speed counter input & (12) triac outputs, [E-41](#)
- 1747-L30L (18) 24 VDC sourcing inputs, high-speed counter input & (12) transistor outputs, [E-44](#)
- 1747-L30P (18) 240 VDC inputs & (12) triac outputs, [E-47](#)
- 1747-L40A (24) 120 VAC inputs & (16) relay outputs, [E-49](#)
- 1747-L40B (24) 120 VAC inputs & (16) triac outputs, [E-51](#)
- 1747-L40C (24) 24 VDC sinking inputs, high-speed counter input & (16) relay outputs, [E-53](#)
- 1747-L40E (24) 24 VDC sinking inputs, high-speed counter input & (16) transistor sourcing outputs, [E-56](#)
- 1747-L40F (24) 24 VDC sinking inputs, high-speed counter input & (16) relay outputs, [E-59](#)
- 1747-L40L (24) 24 VDC sourcing inputs, high-speed counter input & (16) transistor sinking outputs, [E-62](#)
- 1747-L40P (24) 240 VAC inputs (16) triac outputs, [E-65](#)
- operating voltage ranges
 - 1747-L20A (12) 120 VAC inputs & (8) relay outputs, [E-5](#)
 - 1747-L20B (12) 120 VAC inputs & (8) triac outputs, [E-7](#)
 - 1747-L20C (12) 24 VDC sinking inputs, high-speed counter input & (8) relay outputs, [E-10](#)
 - 1747-L20D (12) 24 VDC sinking inputs, high-speed counter input & (8) triac outputs, [E-13](#)
 - 1747-L20E (12) 24 VDC sinking inputs, high-speed counter input & (8) transistor sourcing outputs, [E-16](#)
 - 1747-L20F (12) 24 VDC sinking inputs, high-speed counter input & (8) relay outputs, [E-19](#)
 - 1747-L20G (12) 24 VDC sinking inputs, high-speed counter input & (8) transistor sourcing outputs, [E-22](#)
 - 1747-L20L (12) 24 VDC sourcing inputs, high-speed counter input & (8) transistor sinking outputs, [E-25](#)
 - 1747-L20N (12) 24 VDC sourcing inputs, high-speed counter input & (8) transistor sinking outputs, [E-28](#)
 - 1747-L20P (12) 24 VAC inputs & (8) triac outputs, [E-30](#)
 - 1747-L20R (12) 240 VAC inputs & (8) relay outputs, [E-32](#)
 - 1747-L30A (18) 120 VAC inputs & (12) relay outputs, [E-34](#)
 - 1747-L30B (18) 120 VAC inputs & (12) triac outputs, [E-36](#)
 - 1747-L30C (18) 24 VDC sinking inputs, high-speed counter input & (12) relay outputs, [E-39](#)
 - 1747-L30D (18) 24 VDC sinking inputs, high-speed counter input & (12) triac outputs, [E-42](#)
 - 1747-L30L (18) 24 VDC sourcing inputs, high-speed counter input & (12) transistor outputs, [E-45](#)
 - 1747-L30P (18) 240 VDC inputs & (12) triac outputs, [E-47](#)
 - 1747-L40A (24) 120 VAC inputs & (16) relay outputs, [E-49](#)
 - 1747-L40B (24) 120 VAC inputs & (16) triac outputs, [E-51](#)
 - 1747-L40C (24) 24 VDC sinking inputs, high-speed counter input & (16) relay outputs, [E-54](#)
 - 1747-L40E (24) 24 VDC sinking inputs, high-speed counter input & (16) transistor sourcing outputs, [E-57](#)
 - 1747-L40F (24) 24 VDC sinking inputs, high-speed counter input & (16) relay outputs, [E-60](#)
 - 1747-L40L (24) 24 VDC sourcing inputs, high-speed counter input & (16) transistor sinking outputs, [E-63](#)
 - 1747-L40P (24) 240 VAC inputs (16) triac outputs, [E-65](#)
- operator interface
 - DTAM, [1-10](#)
 - HHT, [1-9](#)
 - IBM compatible computer, [1-9](#)
- output circuit diagrams
 - 1747-L20A (12) 120 VAC inputs & (8) relay outputs, [E-5](#)
 - 1747-L20B (12) 120 VAC inputs & (8) triac outputs, [E-7](#)
 - 1747-L20C (12) 24 VDC sinking inputs, high-speed counter input & (8) relay outputs, [E-10](#)
 - 1747-L20D (12) 24 VDC sinking inputs, high-speed counter input & (8) triac outputs, [E-13](#)
 - 1747-L20E (12) 24 VDC sinking inputs, high-speed counter input & (8) transistor sourcing outputs, [E-16](#)
 - 1747-L20F (12) 24 VDC sinking inputs, high-speed counter input & (8) relay outputs, [E-19](#)

1747-L20G (12) 24 VDC sinking inputs, high-speed counter input & (8) transistor sourcing outputs, [E-22](#)

1747-L20L (12) 24 VDC sourcing inputs, high-speed counter input & (8) transistor sinking outputs, [E-25](#)

1747-L20N (12) 24 VDC sourcing inputs, high-speed counter input & (8) transistor sinking outputs, [E-28](#)

1747-L20P (12) 24 VAC inputs & (8) triac outputs, [E-30](#)

1747-L20R (12) 240 VAC inputs & (8) relay outputs, [E-32](#)

1747-L30A (18) 120 VAC inputs & (12) relay outputs, [E-34](#)

1747-L30B (18) 120 VAC inputs & (12) triac outputs, [E-36](#)

1747-L30C (18) 24 VDC sinking inputs, high-speed counter input & (12) relay outputs, [E-39](#)

1747-L30D (18) 24 VDC sinking inputs, high-speed counter input & (12) triac outputs, [E-42](#)

1747-L30L (18) 24 VDC sourcing inputs, high-speed counter input & (12) transistor outputs, [E-45](#)

1747-L30P (18) 240 VDC inputs & (12) triac outputs, [E-47](#)

1747-L40A (24) 120 VAC inputs & (16) relay outputs, [E-49](#)

1747-L40B (24) 120 VAC inputs & (16) triac outputs, [E-51](#)

1747-L40C (24) 24 VDC sinking inputs, high-speed counter input & (16) relay outputs, [E-54](#)

1747-L40E (24) 24 VDC sinking inputs, high-speed counter input & (16) transistor sourcing outputs, [E-57](#)

1747-L40F (24) 24 VDC sinking inputs, high-speed counter input & (16) relay outputs, [E-60](#)

1747-L40L (24) 24 VDC sourcing inputs, high-speed counter input & (16) transistor sinking outputs, [E-63](#)

1747-L40P (24) 240 VAC inputs (16) triac outputs, [E-65](#)

Output Circuit Operation, [8-10](#)

output contact protection, selecting, [1-16](#)

output modules, troubleshooting, [8-10](#)

Output Specifications, [1-7](#)

P

parts, replacement, [9-1](#)

personal computer requirements, [1-9](#)

planning considerations
hardware, [A-6](#)

overview, [A-6](#)
software, [A-7](#)

Power Considerations

Common Power Source, [2-7](#)

Input States on Power Down, [2-7](#)

line conditions, other types of, [2-7](#)

Loss of Power Source, [2-7](#)

power source, loss of, [2-7](#)

power, removing, [8-2](#)

Preparing Your Wiring Layout, [5-4](#)

preventing machine motion, [6-2](#)

Preventive Maintenance, [2-9](#)

processor not in run mode, [8-4](#)

Program Alteration, [8-3](#)

programming the controller
APS, [1-9](#)
HHT, [1-9](#)

pulses, transient, [1-17](#)

R

RC network, [1-16](#)

Related Publications, [P-3](#)

Relay Contact Ratings, [1-8](#)

remote I/O network
definition, [G-3](#)
overview, [B-1](#)

removable terminal blocks
installing, [5-9](#)
overview, [5-8](#)
removing, [5-8](#)
using, [5-8](#)

Removing Power, [8-2](#)

Replacement Parts, [9-1](#)

replacement terminal covers for 4, 8, & 16 I/O modules, [9-1](#)

retainer clips
replacement part, [9-1](#)
replacing, [7-6](#)

RS-232 Communication Interface
definition, [G-3](#)
overview, [C-1](#)
SLC 500 supportive devices, [C-2](#)
wiring connectors, [C-3](#)

RS-232 connector pin assignments
1746-BAS, [C-8](#)
1747-KE, [C-7](#)
1770-KF3, [C-8](#)
1771-KGM, [C-10](#)
1775-KA, [C-11](#)
2760-RB, [C-9](#)

5130-RM, [C-13](#)
IBM AT, [C-6](#)
PLC-5, [C-12](#)

RS-232 supportive devices
1746-BAS module, [C-2](#)
1747-KE module, [C-2](#)
1770-KF3 module, [C-2](#)

S

Safety Considerations

Disconnecting Main Power, [2-8](#)
Distributing Power, [2-9](#)
Testing the Master Control Relay Circuit,
[2-9](#)
Wiring Safety Circuits, [2-9](#)

SCADA applications, [C-1](#)

selecting

2-slot expansion chassis, [1-8](#)
contact protection, [1-16](#)
discrete I/O modules, [1-8](#)
enclosures, [1-9](#)
fixed controller, [1-1](#)
isolation transformers, [1-12](#)
operator interfaces, [1-9](#)
specialty I/O modules, [1-8](#)
surge suppressors, [1-14](#)

sinking and sourcing

contact output circuits, [5-2](#)
definition, [G-4](#)
overview, [5-1](#)
Sinking Device with Sourcing Input
Module Circuit, [5-3](#)
Sinking Device with Sourcing Output
Module Circuit, [5-3](#)
Solid-State DC I/O Circuits, [5-2](#)
Sourcing Device with Sinking Input
Module Circuit, [5-2](#)
Sourcing Device with Sinking Output
Module Circuit, [5-3](#)

SLC 500 BASIC Module Design and
Integration Manual, [C-2](#)

SLC 500 Family of Small Programmable
Controllers, system overview, [1-1](#)

Spacing Your Components, [2-2](#)

Special Considerations

Excessive Line Voltage Variations, [1-13](#)
Excessive Noise, [1-13](#)
Selecting Contact Protection, [1-16](#)
Selecting Surge Suppressors, [1-14](#)
Transistor Output Transient Pulses,
[1-17](#)

specialty I/O modules
features, [5-5](#)
installing, [4-2](#)
replacing retainer clips, [7-6](#)
selecting, [1-8](#)

specifications

1747-AIC link coupler electrical-optical
isolation, [1-3](#)
24 VDC user power output tolerance,
[1-3](#)
ambient temperature rating, [1-3](#)
bit execution, [1-3](#)
certification, [1-3](#)
humidity, [1-3](#)
I/O electrical-optical isolation, [1-3](#)
LED indicators, [1-3](#)
maximum power requirement, [1-3](#)
memory backup options, [1-3](#)
noise immunity, [1-3](#)
power supply fuse protection, [1-3](#)
power supply inrush rating, [1-3](#)
power supply operating voltage, [1-3](#)
program memory, [1-3](#)
program scan hold-up time after loss of
power, [1-3](#)
scan time, [1-3](#)
vibration, [1-3](#)
wire size, [1-3](#)

specifications for inputs, [1-6](#)

specifications for outputs, [1-7](#)

surge suppressor

definition, [G-4](#)
selecting, [1-14](#)

system does not operate per ladder logic,
[8-6](#)

system does not operate per programmed
forces, [8-7](#)

system inoperable, no major CPU faults
detected, [8-5](#)

T

testing

inputs, [6-4](#)
outputs, [6-6](#)
processor, [6-3](#)
program, [6-8](#)

Transistor Output Transient Pulses, [1-17](#)

Troubleshooting

Calling Allen-Bradley for Assistance,
[8-1](#)

control system, [8-2](#)
fixed controller, [8-3](#)
input modules, [8-8](#)
output modules, [8-10](#)

U

UVPROM memory module
definition, [G-4](#)
installing, [4-4](#)
overview, [1-11](#)
replacement part, [9-1](#)

V

varistor, [1-16](#)

W

watts per point, [D-1](#), [G-4](#)
Who Should Use this Manual, [P-1](#)
wire/terminal connections
for new Belden #9842, [A-12](#)
for old Belden #9842, [A-12](#)
wiring diagrams
1747-L20A (12) 120 VAC inputs & (8)
relay outputs, [E-4](#)
1747-L20B (12) 120 VAC inputs & (8)
triac outputs, [E-6](#)
1747-L20C (12) 24 VDC sinking inputs,
high-speed counter input & (8) relay
outputs, [E-8](#)
1747-L20D 12 (24) VDC sinking inputs,
high-speed counter input & (8) triac
outputs, [E-11](#)
1747-L20E (12) 24 VDC sinking inputs,
high-speed counter input & (8)
transistor sourcing outputs, [E-14](#)
1747-L20F (12) 24 VDC sinking inputs,
high-speed counter input & (8) relay
outputs, [E-17](#)
1747-L20G (12) 24 VDC sinking inputs,
high-speed counter input & (8)
transistor sourcing outputs, [E-20](#)
1747-L20L (12) 24 VDC sourcing inputs,
high-speed counter input & (8)
transistor sinking outputs, [E-23](#)
1747-L20N (12) 24 VDC sourcing inputs,
high-speed counter input & (8)
transistor sinking outputs, [E-26](#)

1747-L20P (12) 24 VAC inputs & (8) triac
outputs, [E-29](#)
1747-L20R (12) 240 VAC inputs & (8)
relay outputs, [E-31](#)
1747-L30A (18) 120 VAC inputs & (12)
relay outputs, [E-33](#)
1747-L30B (18) 120 VAC inputs & (12)
triac outputs, [E-35](#)
1747-L30C (18) 24 VDC sinking inputs,
high-speed counter input & (12)
relay outputs, [E-37](#)
1747-L30D (18) 24 VDC sinking inputs,
high-speed counter input & (12)
triac outputs, [E-40](#)
1747-L30L (18) 24 VDC sourcing inputs,
high-speed counter input & (12)
transistor outputs, [E-43](#)
1747-L30P (18) 240 VDC inputs & (12)
triac outputs, [E-46](#)
1747-L40A (24) 120 VAC inputs & (16)
relay outputs, [E-48](#)
1747-L40B (24) 120 VAC inputs & (16)
triac outputs, [E-50](#)
1747-L40C (24) 24 VDC sinking inputs,
high-speed counter input & (16)
relay outputs, [E-52](#)
1747-L40E (24) 24 VDC sinking inputs,
high-speed counter input & (16)
transistor sourcing outputs, [E-55](#)
1747-L40F (24) 24 VDC sinking inputs,
high-speed counter input & (16)
relay outputs, [E-58](#)
1747-L40L (24) 24 VDC sourcing inputs,
high-speed counter input & (16)
transistor sinking outputs, [E-61](#)
1747-L40P (24) 240 VAC inputs (16) triac
outputs, [E-64](#)
sinking input circuit – high-speed
counter, [4-7](#)
sourcing input circuit – high-speed
counter, [4-7](#)
wiring I/O devices
bundling, [5-6](#)
identifying terminals, [5-6](#)
labeling, [5-6](#)
recommendations for, [5-6](#)
wire gauge, [5-6](#)
wiring layout preparation, [5-4](#)
Wiring Your I/O Modules, [5-7](#)



ALLEN-BRADLEY
A ROCKWELL INTERNATIONAL COMPANY

Allen-Bradley has been helping its customers improve productivity and quality for 90 years. A-B designs, manufactures and supports a broad range of control and automation products worldwide. They include logic processors, power and motion control devices, man-machine interfaces and sensors. Allen-Bradley is a subsidiary of Rockwell International, one of the world's leading technology companies.



With major offices worldwide.

Algeria • Argentina • Australia • Austria • Bahrain • Belgium • Brazil • Bulgaria • Canada • Chile • China, PRC • Colombia • Costa Rica • Croatia • Cyprus • Czech Republic • Denmark • Ecuador • Egypt • El Salvador • Finland • France • Germany • Greece • Guatemala • Honduras • Hong Kong • Hungary • Iceland • India • Indonesia • Israel • Italy • Jamaica • Japan • Jordan • Korea • Kuwait • Lebanon • Malaysia • Mexico • New Zealand • Norway • Oman • Pakistan • Peru • Philippines • Poland • Portugal • Puerto Rico • Qatar • Romania • Russia-CIS • Saudi Arabia • Singapore • Slovakia • Slovenia • South Africa, Republic • Spain • Switzerland • Taiwan • Thailand • The Netherlands • Turkey • United Arab Emirates • United Kingdom • United States • Uruguay • Venezuela • Yugoslavia

World Headquarters, Allen-Bradley, 1201 South Second Street, Milwaukee, WI 53204 USA, Tel: (1) 414 382-2000 Fax: (1) 414 382-4444