

BERGER LAHR

Catalogue

Motion Controller



a company of
Schneider
Electric

Berger Lahr Motion Control	2
Motion Control solutions	4
Available products	7
TLCC Cell Controller	
Product description	8
Technical data	10
Dimensional drawings	11
Mounting and installation	12
Order data/accessories	13
TLM2 multi-axis Motion Controller	
Product description	14
Technical data	16
Dimensional drawings	17
Mounting and installation	18
Order data/accessories	19
SMC Smart Motion Controller	
Product description	20
Technical data	22
Dimensional drawings	23
Mounting and installation	23
Order data/accessories	24
TLC6 Motion Controller with drive booster	
Product description	25
Technical data	29
Dimensional drawings	33
Mounting and installation	36
Options for TLC6•P with degree of protection IP54	39
Type code	40
Interfaces for communication	42
Programming	
Run-time system TLCC_V3	44
Operating system RT-Linux	45
Programming system	
Introduction	46
Programming languages	48
Components	50
SoftMotion	53
Block libraries	56
Accessories	
Terminals for TLCC and TLM2	64
For TLC6	68
Appendix	
Conversion tables	72

Berger Lahr Motion Control

Complete range of available products and services

Berger Lahr offers a complete range of products and services for almost all automation tasks.

Motion Controllers

All Motion Controllers from Berger Lahr are controllers with user-programmable PLC and motion functions. Programming is performed on the basis of known standards in accordance with IEC 61131-3 and PLCOpen.

Drives

Berger Lahr offers a wide range of drive technology: stepper motor, DC brushless motor and AC servo drives. Motors and drives are optimally matched to one another. The booster is integrated in the motor in IclA intelligent compact drives.

Linear motion

The product range is supplemented by linear axes and axis combinations with spindle or toothed belt drive.

Global support

Qualified sales partners support customers all over the world, from selecting the appropriate products through to commissioning. The range of services includes: Consulting > Project planning > Programming > Commissioning > Training > Support
Berger Lahr sales agencies receive round-the-clock hotline support from headquarters in Lahr.

Successful solutions in many industries

Products from Berger Lahr are used in many industries, such as printing and paper, textiles, beverages and foodstuffs, wood, metal, pharmaceuticals, semi-conductor production, automobile production. The Motion Controllers are used for controlling movements in machines or systems, such as synchronous material handling, pick & place, format adjustment, cutting (e.g. with rotating blade), sawing (e.g. flying saw), glue application (2½-D interpolation).

Development partner for customer-specific solutions

Standard products do not always provide customers with the optimum solution. As a result, Berger Lahr offers manufacturers of standard machines the opportunity to adapt their standard products to customer-specific requirements. Together with the customer, we specify the functions and then develop and produce the appropriate product. If necessary, Berger Lahr can take over the design of the product based on the customer's corporate design.

Berger Lahr product structure

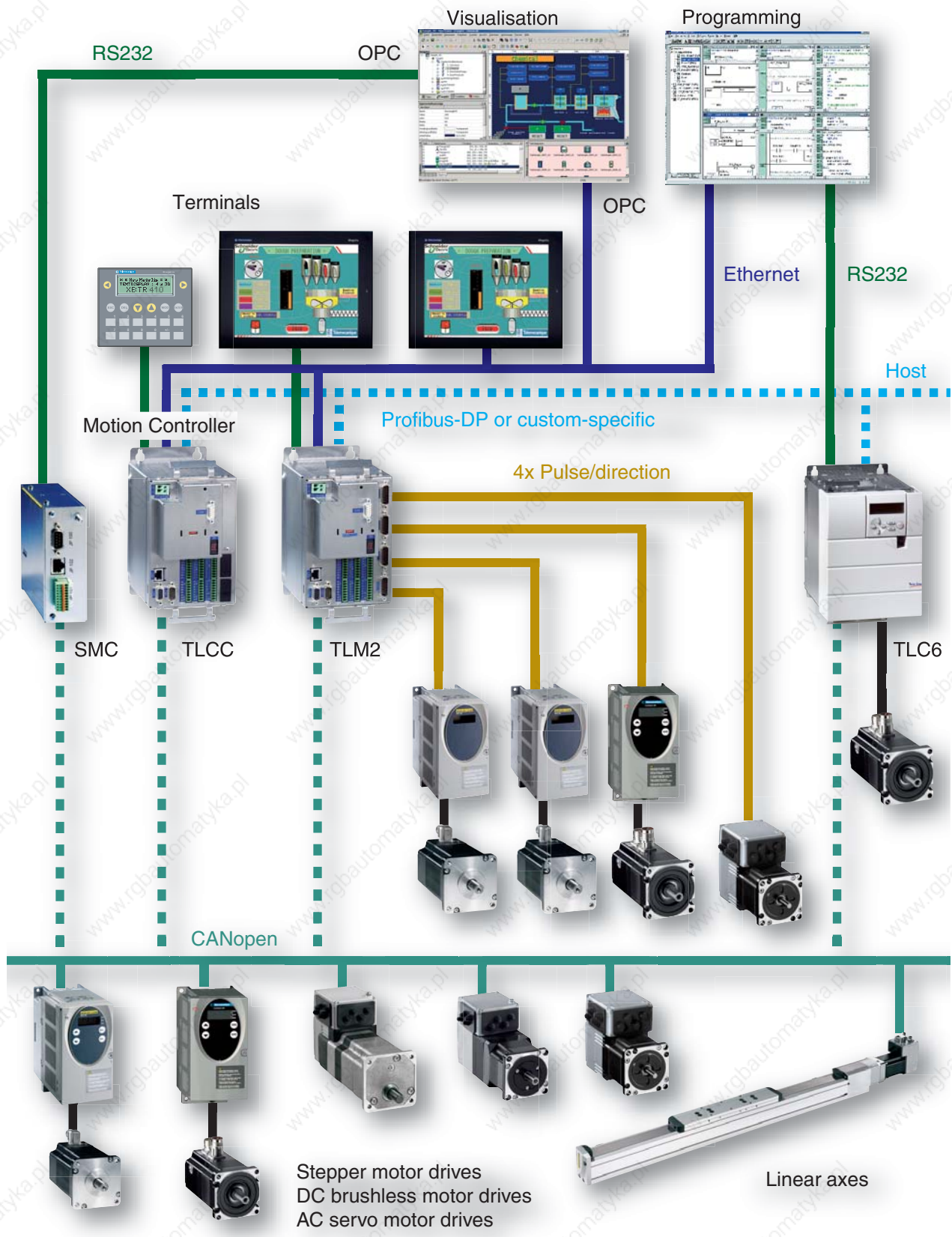

Highly synchronous material handling in a printing machine

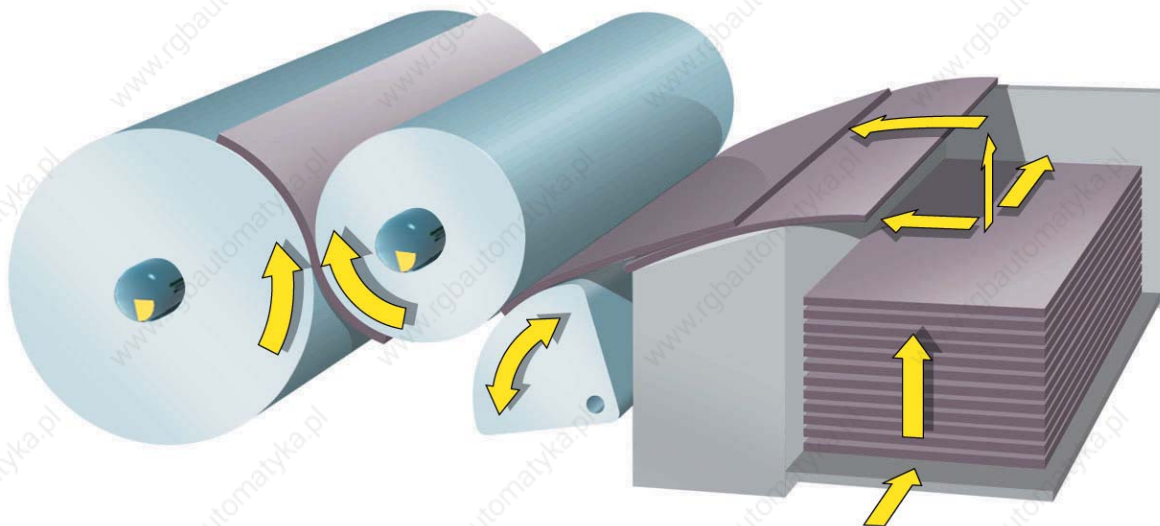

2½-D interpolation in a cutting robot

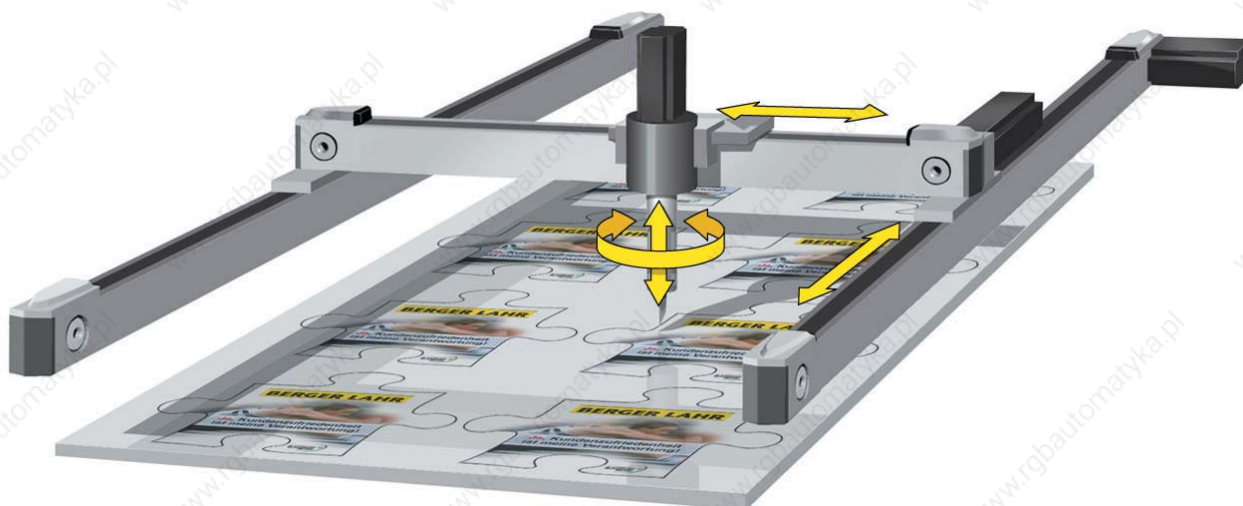

Cutting of endless material with a rotating blade

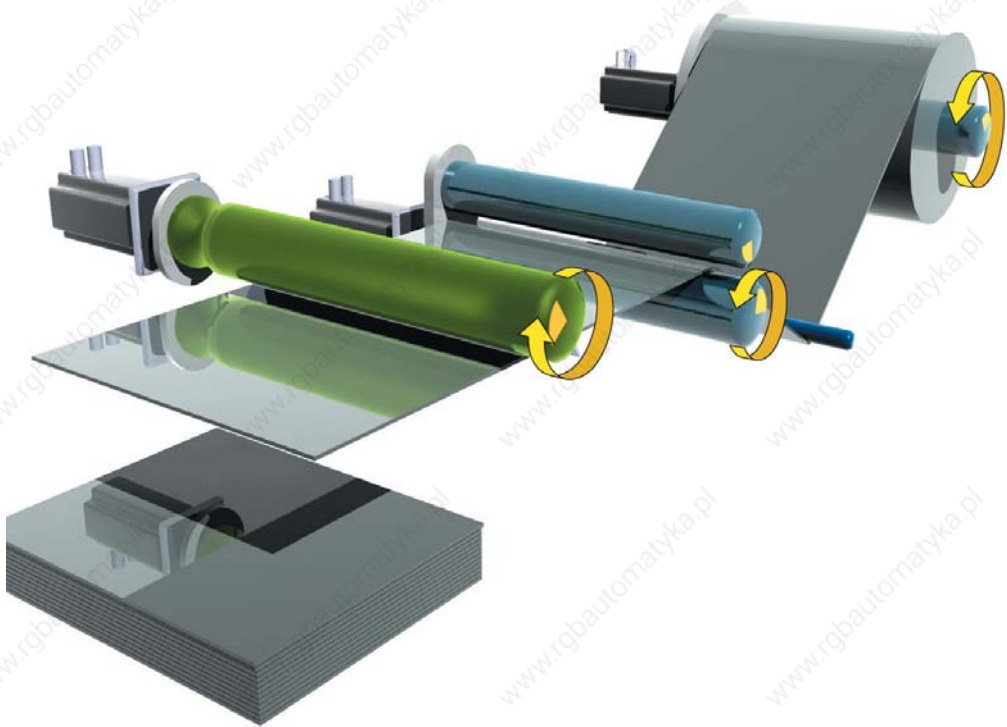

Labeling on the fly

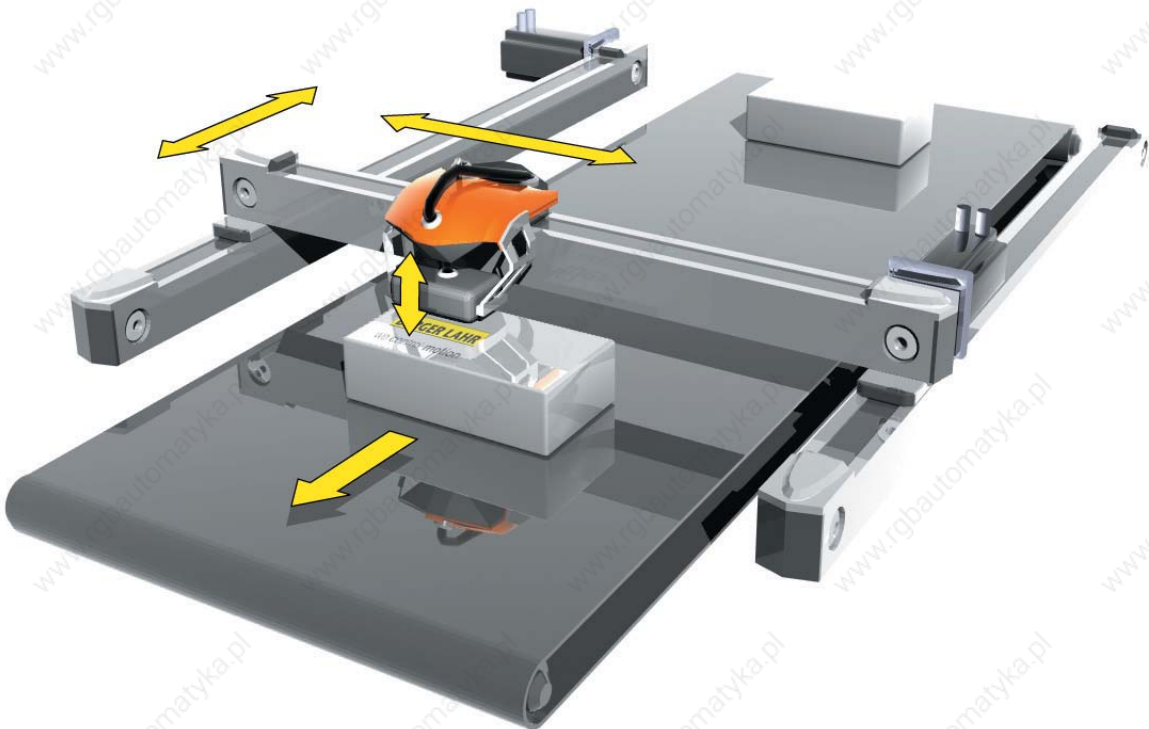



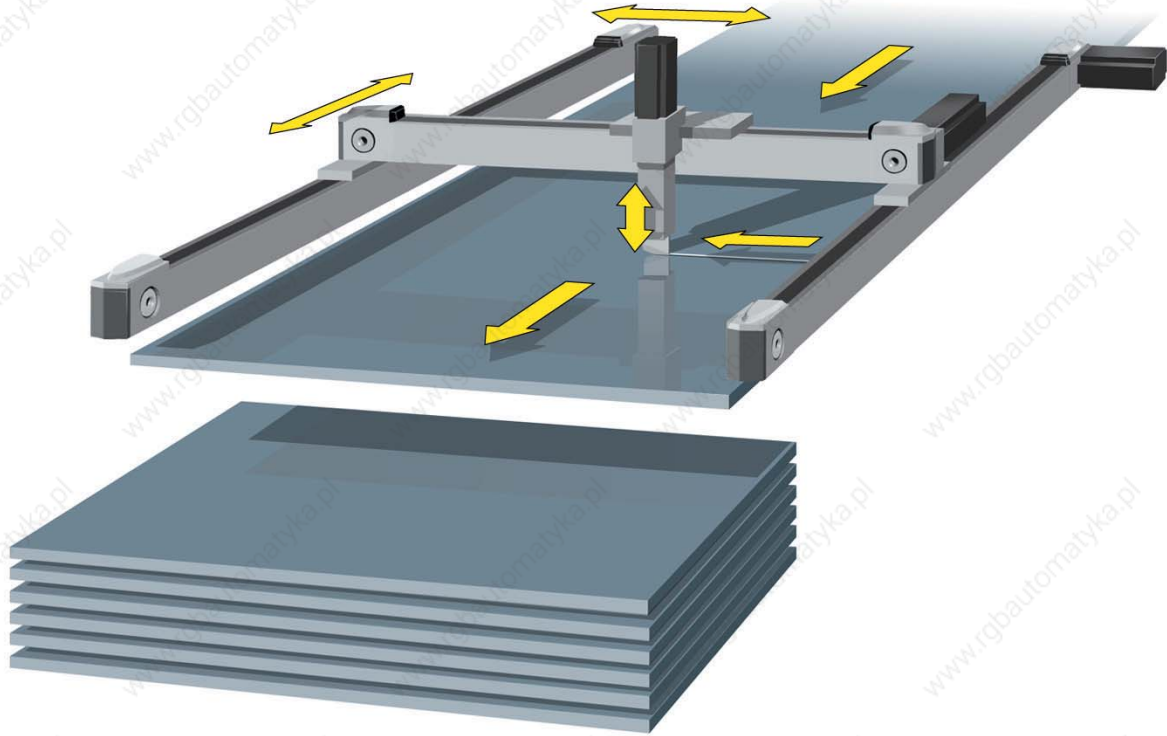

Flying saw

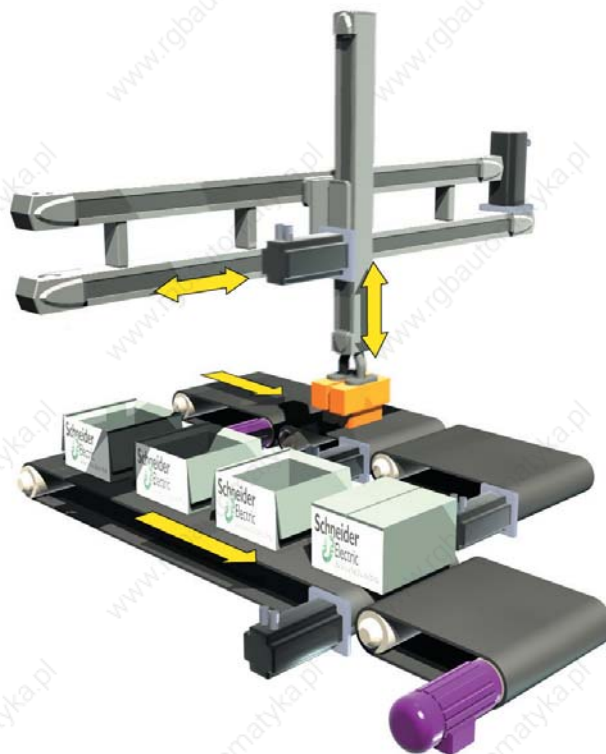

Pick & place robot



Available products					
	Motion Controllers				
	Without drive booster			With drive booster	
	TLCC	TLM2	SMC	TLC61	TLC63
					
Drive interfaces	CANopen master (max. 126 drives)	4 x pulse/direction CANopen master (max. 126 drives)	CANopen master (max. 32 drives)	Connection for stepper motor CANopen master (max. 126 drives)	Connection for AC servomotor and CANopen master (max. 126 drives)
User-defined inputs/outputs	32 / 16	32 / 16	8, bidirectional	14 / 5	
Programming and operating interface	Ethernet TCP/IP, RS232	Ethernet TCP/IP, RS232	RS232 ¹⁾	RS-232	
Communication via OPC	Ethernet TCP/IP	Ethernet TCP/IP	RS232 ¹⁾	RS-232	
Fieldbus interface (optional)	Profibus-DP slave ²⁾	Profibus-DP slave ²⁾	None	Profibus-DP slave, CANopen slave, Modbus, RS485	
Berger Lahr programming system	Yes	Yes	Yes	Yes	
PLCopen single-axis function blocks	Yes	Yes	Yes	Yes	
PLCopen multi-axis function blocks	No	Yes	No	Yes	
NC editors	No	Yes	No	No	
Cam profile editor	No	Yes	No	Yes	
Motion functions	<ul style="list-style-type: none"> Reference movement Manual mode Point-to-point mode Coordinated movements of several axes 	<ul style="list-style-type: none"> Reference movement Manual mode Point-to-point mode 2½-D interpolation Electronic cam profile with up to four axes Cam index gear Synchronous angle running with up to four axes Highly synchronous movements of up to four axes 	<ul style="list-style-type: none"> Reference movement Manual mode Point-to-point mode Speed mode 	<ul style="list-style-type: none"> Reference movement Manual mode Point-to-point mode Speed mode Teach-in of position values Cam index gear Electronic gear Oscillator mode Safety functions 	

¹⁾ The SMC has an RS485 interface. An RS485/RS232 adapter is required for connection to a PC, see SMC accessories.

²⁾ other fieldbus interfaces on request



TLCC Cell Controller

Product description

Introduction

The Twin Line Cell Controller TLCC is a Motion Controller with an integrated, very high-performance software PLC. The TLCC has a web server. In addition, a Modbus server is integrated to facilitate connection to Magelis terminals of the XBT series from Schneider Electric via RS232 or Ethernet.

Application fields

- Autonomous production cells that require motion and PLC functions. The TLCC can replace a conventional PLC to a certain extent in production cells such as these.
- Applications that require coordinated or independent movements, e.g. pick & place, handling, assembly and testing.
- Applications that need a connection to a company network.
- Intelligent gateway

Motion functions

- Reference movement
- Manual mode
- Peer-to-peer
- Coordinated movements of several axes

Programming system

All Motion Controllers described in this catalogue can be programmed using the Berger Lahr programming system in accordance with IEC 61131-3. The programming system is available on CD-ROM, see page 46.

The following interfaces can be used in order to transfer the user programmes onto the TLCC.

- RS-232
- Ethernet

Features

Drive interfaces	CANopen (max. 126 drives)
User-defined inputs/outputs	32 / 16
Programming and operating interface	Ethernet TCP/IP, RS232
Communication via OPC	Ethernet TCP/IP
Fieldbus interface (optional)	Profibus-DP slave ¹⁾
Berger Lahr programming system	Yes
PLCopen single-axis function blocks	Yes
PLCopen multi-axis function blocks	No
NC editors	No
Cam profile editor	No

¹⁾ other fieldbus interfaces on request

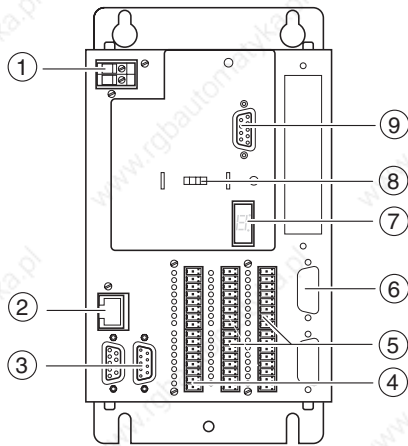

Overview of devices

- (1) 24 V supply voltage
- (2) Ethernet
- (3) CAN IN/OUT
- (4) 16 outputs
- (5) 32 Inputs
- (6) Profibus-DP interface (optional)
- (7) 7-segment display
- (8) RS232 interface changeover: programming/communication
- (9) RS232 serial interface

Interfaces

CAN interface

The TLCC is a CANopen master and controls a maximum of 126 slave devices.

RS 232 interface

The RS232 interface is used for transmitting application programmes to the Motion Controller. In addition, the RS232 interface can be used as a communications interface to other devices, e.g. terminals. It is possible to changeover between the two functions using a switch on the front of the Motion Controller.

Ethernet interface

The Ethernet interface is used for remote control of the Motion Controller as well as for transmission or debugging of user programmes. Amongst other functions, this includes updating the operating system and exchanging process data with higher-level host systems via OPC.

Profibus-DP slave interface (optional)

On request, the TLCC can be equipped with a Profibus-DP slave interface.

Inputs and Outputs

The freely useable, process-capable 32 inputs and 16 outputs of the TLCC also contribute to reducing the number of additional components and therefore to saving costs.

Technical data		
Electrical data		
Electrical power supply		PELV power supply unit in accordance with DIN 19240, with reverse polarity protection
Input voltage	V _{DC}	21 ... 28
Minimum current consumption	mA	1000
Output voltage	V _{DC}	5 ±5%
Overcurrent protection	A	>10 on the output side (5 V)
Max. mains failure bridging	ms	10
RS 232 interface		
Max. baud rate	kbaud	115
Max. cable length	m	15
Ethernet interface		
		RJ45 female connector; Ethernet TCP/IP protocol, programming or communication with the host system
CANopen interface		
		CiA DS 301 V4.02 CANopen application layer and communication profile; CiA DS 405 V2.0 CANopen interface and device profile for IEC 61131-3 programmable devices
Max. baud rate	Mbaud	1 (default setting 500 kbaud)
Max. number of slaves		126
Profibus-DP slave interface (optional)		
Specification		EN 50170
Max. baud rate	Mbaud	12
Min. baud rate	kbaud	9.6
Cable specification		Profibus cable, preferably type A
Digital inputs		
		Short-circuit protected, filtered, over-voltage protection
Number of inputs		32, freely useable
Max. input voltage	V _{DC}	30
Switching threshold low -> high	V _{DC}	≥10
Switching threshold high -> low	V _{DC}	≤5
Input resistance (pull-down to VM)	kΩ	3.3 ±0.5
Debounce time	μs	500
Max. cable length with 0.25 mm ² cross-sectional area	m	100
Digital outputs		
		Short-circuit protected, over-voltage protection
Number of outputs		16, freely useable
Max. residual voltage at signal mode low	mV	<200
Max. output voltage	V _{DC}	28
Max. output current	mA	500
Voltage drop when loaded with 500 mA	V _{DC}	<2
Memory		
Main memory:		
• Main memory (RAM)	MB	64
• Memory for CoDeSys application (flash)	MB	32
• Application data (RAM)	MB	13
• Non-volatile data of the application (flash)	kB	32
Programme processing time		
Processor type: Intel Pentium II 266 MHz, average processing time for 1000 lines of an IL code	μs	25.6
Mechanical data		
Weight	kg	2.0
Index of protection to DIN EN 60529:2000-09		IP20
Ambient conditions		
Ambient temperature	°C	0 ... +50
Transport and storage temperature	°C	-40 ... +70
Rel. humidity	%	15 ... 85 (no condensation permitted)
Max. installation altitude	m above sea level	1000

Dimensional drawings

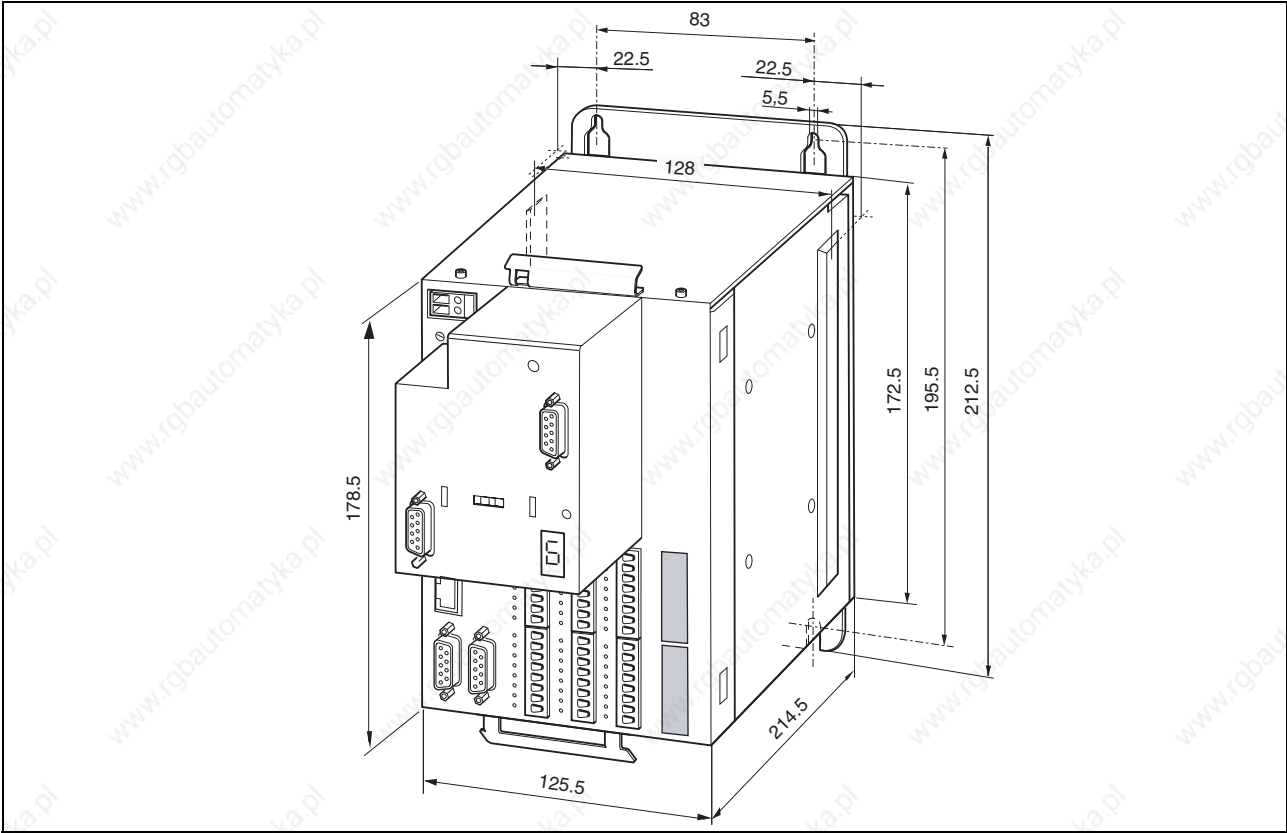

TLCC dimensional drawing

Mounting and installation

EMC-compliant installation

EMC-installation is essential for compliance with the specified limit values. Better results can be achieved using the following measures, depending on the application:

- Connecting mains reactors ahead in series. Specifications for current harmonics are available on request.
- Connecting mains filter ahead in series, in particular to comply with limit values for the first environment (living area, category C2)
- Installation in an enclosed control cabinet with 15 dB attenuation of the emitted radiation

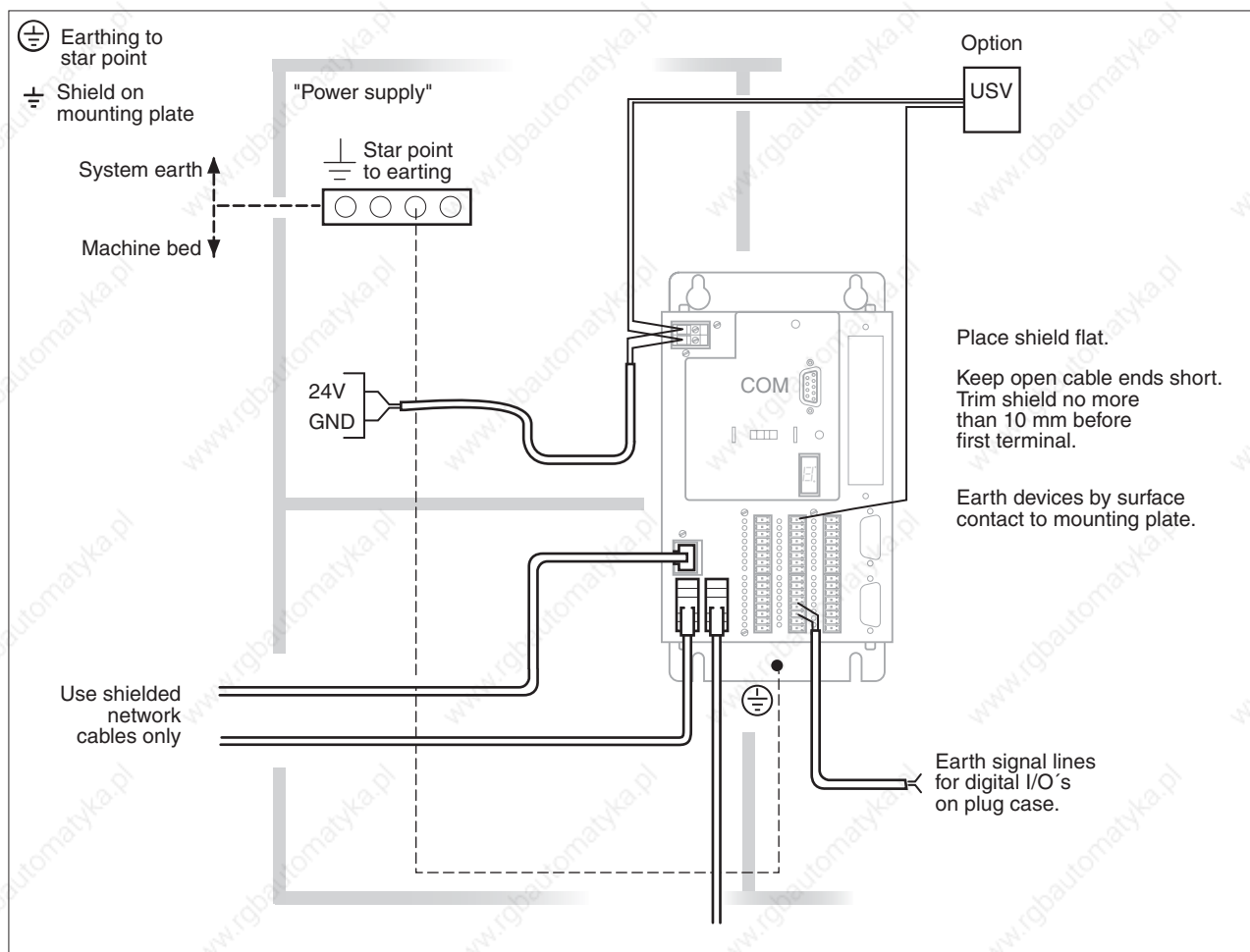

EMC measures TLCC

Mechanical installation

Control cabinet

The size of the control cabinet must be such that all devices and components can be firmly installed in it and wired up in accordance with EMC regulations.

The control cabinet ventilation must be capable of evacuating the heat losses by all devices and components installed in the control cabinet.

Position the Motion Controller in the control cabinet so that the heated air flow from other devices, e.g. an external ballast resistor, does not result in undesirable heating of the device cooling air.

Install the Motion Controller vertically with the 24 V_{DC} connection at the top.

Secure the Motion Controller to a galvanized metal plate. The back wall of the Motion Controller must make good contact with the metal plate over a wide area.

Installation clearances

The ventilation openings on and underneath the device must be at least 70 mm away from adjacent devices or walls.

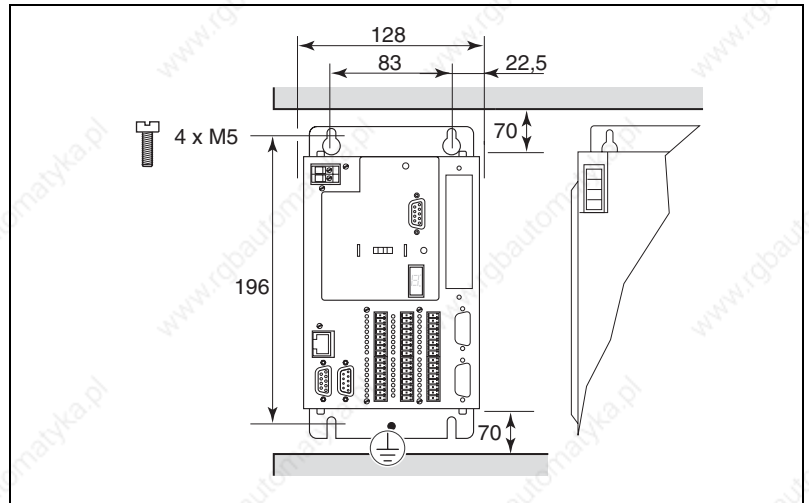

Installation clearances, dimensions in mm

Order data

Designation	Description	Order number
TLCC	TLCC RS232/ETH/CANopen	008650500007
TLCC with Profibus-DP slave interfaces	TLCC RS232/ETH/CANopen/Profibus slave	008650500008

Accessories

Designation	Description	Order number
TLCC/TLM connector set ACC3CS004NNNN	Scope of delivery: <ul style="list-style-type: none"> • 1 SubD adapter with CAN terminating resistor • 6 plug connectors 	0086300901002
CD-ROM with programming software ACC4PACDS0001XX	The CD-ROM contains: <ul style="list-style-type: none"> • Installation files • Block libraries • Online help and documentation 	0062501102600

Note: Information about additional accessories can be found from page 64 onwards.



TLM2 Multi-Axis Motion Controller

Product description

Introduction

The Twin Line Multi-Axis Controller is a Motion Controller with an integrated, very high-performance software PLC. The TLM2 has a web server. In addition, a Modbus server is integrated to facilitate connection to Magelis terminals of the XBT series from Schneider Electric via RS232 or Ethernet. This very high-performance multi-axis controller performs not only motion coordination but also highly synchronous motion functions.

The TLM2 can control up to four drives highly synchronously via the pulse/direction interface. This allows even inexpensive drives – such as Twin Line, Lexium 05 and IclA with pulse/direction inputs – to be used for demanding motion profiles. In addition, an incremental encoder (RS422) can be connected to the TLM2 for supplying the value set.

Application fields

- Autonomous production cells that require motion and PLC functions. The TLM2 can usually replace a conventional PLC to a certain extent in production cells such as these.
- Applications that require coordinated or independent movements, e.g. pick & place, handling, assembly and testing
- Applications that need a connection to a company network
- Applications that require track movement by 2½-D interpolation, such as applying glue, cutting forms and figures, axis portals
- Applications in which technology functions are required, such as cam profile, cam switching, synchronous angle running
- Coordination of demanding axis movements in master/slave synchronisation or as NC axes with spline, parabola, circle or linear interpolation
- Intelligent gateway

Motion functions

- Reference movement
- Manual mode
- Point-to-point mode
- 2½-D interpolation
- Electronic cam profile with up to four axes
- Cam index gear
- Synchronous angle running with up to four axes
- Electronic gear
- Highly synchronous movements of up to four axes

Programming system

All Motion Controllers described in this catalogue can be programmed using the Berger Lahr programming system in accordance with IEC 61131-3. The programming system is available on CD-ROM, see page 46.

The following interfaces can be used for transmitting the user programmes to the TLM2.

- RS-232
- Ethernet

Features

Drive interfaces	4 x pulse/direction; CANopen (max. 126 drives)
User-defined inputs/outputs	32 / 16
Programming and operating interface	Ethernet TCP/IP, RS232
Communication via OPC	Ethernet TCP/IP
Fieldbus interface (optional)	Profibus-DP slave ¹⁾
Berger Lahr programming system	Yes
PLCopen single-axis function blocks	Yes
PLCopen multi-axis function blocks	Yes
NC editors	Yes
Cam profile editor	Yes

¹⁾ other fieldbus interfaces on request

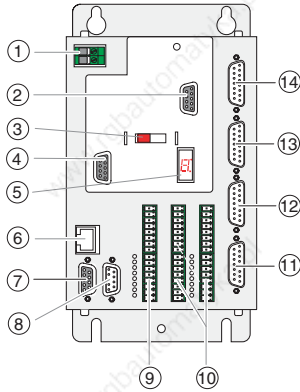

Overview of devices

- (1) 24 V supply voltage
- (2) RS-232 serial interface
- (3) Changeover RS232: Programming/communication
- (4) Profibus-DP slave interface (optional)
- (5) 7-segment display
- (6) Ethernet
- (7) RS422 encoder
- (8) CAN
- (9) 16 outputs
- (10) 32 Inputs
- (11) Axis 4
- (12) Axis 3
- (13) Axis 2
- (14) Axis 1

Interfaces

Pulse/direction interfaces

The TLM2 has four mutually independent pulse/direction interfaces for implementing highly synchronous movements.

CANopen interface

The TLM2 is a CANopen master and controls a maximum of 126 slave devices

RS 232 interface

The RS232 interface is used for transmitting application programmes to the Motion Controller. In addition, the RS232 interface can be used as a communications interface to other devices, e.g. terminals. It is possible to changeover between the two functions using a switch on the front of the Motion Controller.

Ethernet interface

The Ethernet interface is used for remote control of the Motion Controller as well as for transmission or debugging of user programmes. Amongst other functions, this includes updating the operating system and exchanging process data with higher-level host systems via OPC.

RS422 encoder interface

The TLM2 is equipped with an RS422 encoder interface for providing the guidance parameters via an incremental encoder.

Profibus-DP slave interface (optional)

On request, the TLM2 can be equipped with a Profibus-DP interface.

Technical data		
Electrical data		
Electrical power supply		PELV power supply unit in accordance with DIN 19240, with reverse polarity protection
Input voltage	V _{DC}	21 ... 28
Minimum current consumption	mA	1000
Output voltage	V _{DC}	5 ±5%
Overcurrent protection	A	>10 on the output side (5 V)
Max. mains failure bridging	ms	10
RS 232 interface		
Max. baud rate	kbaud	115
Max. cable length	m	15
Ethernet interface		RJ45 female connector; Ethernet TCP/IP protocol, programming or communication with the host system
CANopen interface		CiA DS 301 V4.02 CANopen application layer and communication profile; CiA DS 405 V2.0 CANopen interface and device profile for IEC 61131-3 programmable devices
Max. baud rate	Mbaud	1 (default setting 500 kbaud)
Max. number of slaves		126
Pulse/direction interfaces		
Specification		RS-422
Number of interfaces		4
Max. switching voltage	V	4
Min. residual voltage	mV	220
Max. output current	mA	16
Signals		Pulse, direction gate, current control, ready
PWM (pulse width modulation)		
• Frequency of the signal	kHz	15.625
• Resolution	bit	8 (256 steps)
Encoder interface		
Specification		RS-422
Max. frequency	MHz	1
Max. cable length	m	30
Signal level	V	5
Power supply for encoder	V	5
Profibus-DP slave interface (optional)		
Specification		EN 50170
Max. baud rate	Mbaud	12
Min. baud rate	kbaud	9.6
Cable specification		Profibus cable, preferably type A
Digital inputs		
		Short-circuit protected, filtered, over-voltage protection
Number of inputs		32, freely useable
Max. input voltage	V _{DC}	30
Switching threshold low -> high	V _{DC}	≥10
Switching threshold high -> low	V _{DC}	≤5
Input resistance (pull-down to VM)	kΩ	3.3 ±0.5
Debounce time	μs	500
Max. cable length with 0.25 mm ² cross-sectional area	m	100
Digital outputs		
		Short-circuit protected, over-voltage protection
Number of outputs		16, freely useable.
Max. residual voltage at signal mode low	mV	200
Max. output voltage	V _{DC}	28
Max. output current	mA	500
Voltage drop when loaded with 500 mA	V _{DC}	<2

Technical data

Memory		
Main memory:		
• Main memory (RAM)	MB	64
• Memory for CoDeSys application (flash)	MB	32
• Application data (RAM)	MB	13
• Non-volatile data of the application (flash)	kB	32
Programme processing time		
Average processing time for 1000 lines of an IL code	µs	25.6
Mechanical data		
Weight	kg	2.0
Index of protection to DIN EN 60529:2000-09		IP20
Ambient conditions		
Ambient temperature	°C	0 ... +50
Transport and storage temperature	°C	-40 ... +70
Rel. humidity	%	15 ... 85 (no condensation permitted)
Max. installation altitude	m above sea level	1000

Dimensional drawings

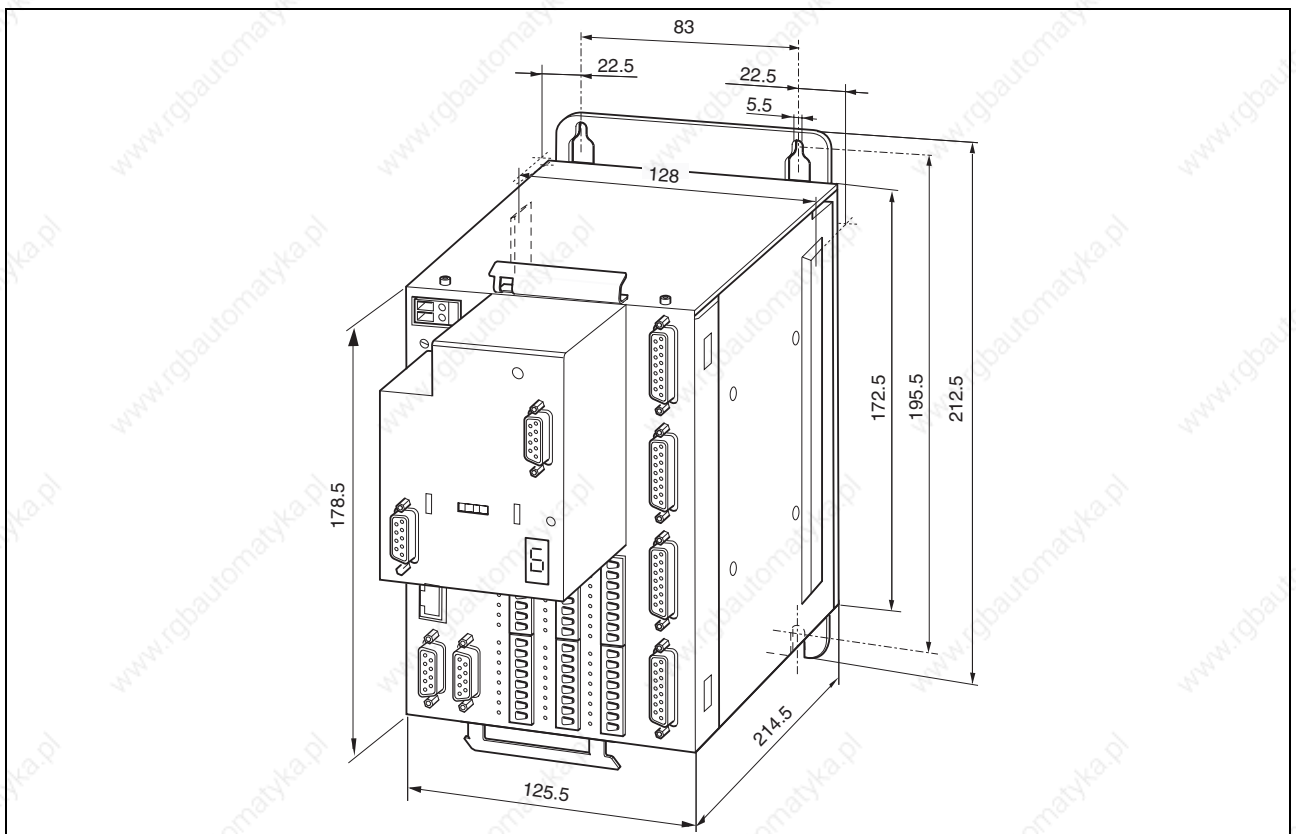

Dimensional drawing TLM2

Mounting and installation

EMC-compliant installation

EMC-installation is essential for compliance with the specified limit values. Better results can be achieved using the following measures, depending on the application:

- Connecting mains reactors ahead in series. Specifications for current harmonics are available on request.
- Connecting mains filter ahead in series, in particular to comply with limit values for the first environment (living area, category C2)
- Installation in an enclosed control cabinet with 15 dB attenuation of the emitted radiation

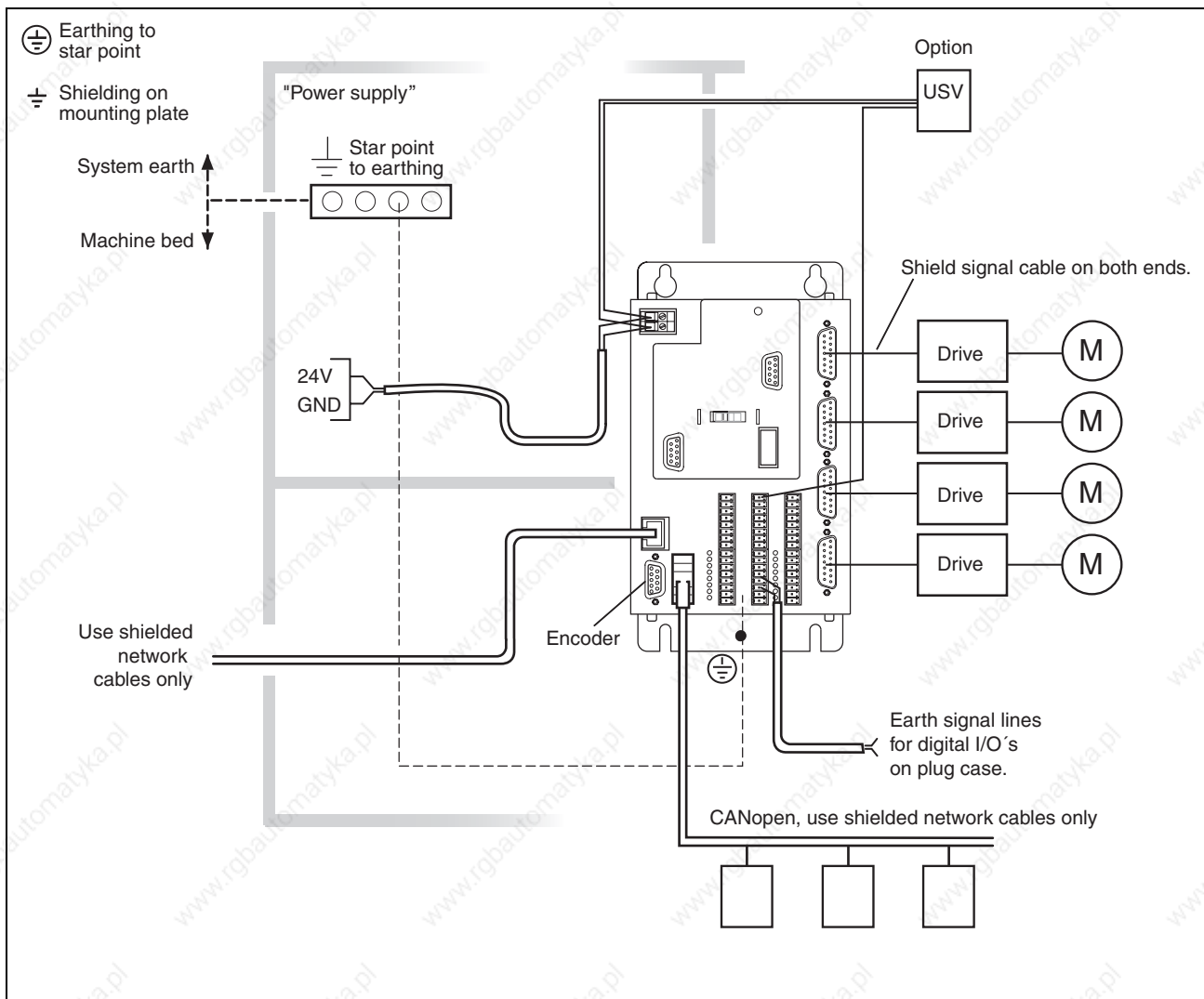

EMC measures TLM2

Mechanical installation

Control cabinet

The size of the control cabinet must be such that all devices and components can be firmly installed in it and wired up in accordance with EMC regulations.

The control cabinet ventilation must be capable of evacuating the heat losses by all devices and components installed in the control cabinet.

Position the Motion Controller in the control cabinet so that the heated air flow from other devices, e.g. an external ballast resistor, does not result in undesirable heating of the device cooling air.

Install the Motion Controller vertically with the 24 V_{DC} connection at the top.

Secure the Motion Controller to a galvanized metal plate. The back wall of the Motion Controller must make good contact with the metal plate over a wide area.

Installation clearances

The ventilation openings on and underneath the device must be at least 70 mm away from adjacent devices or walls.

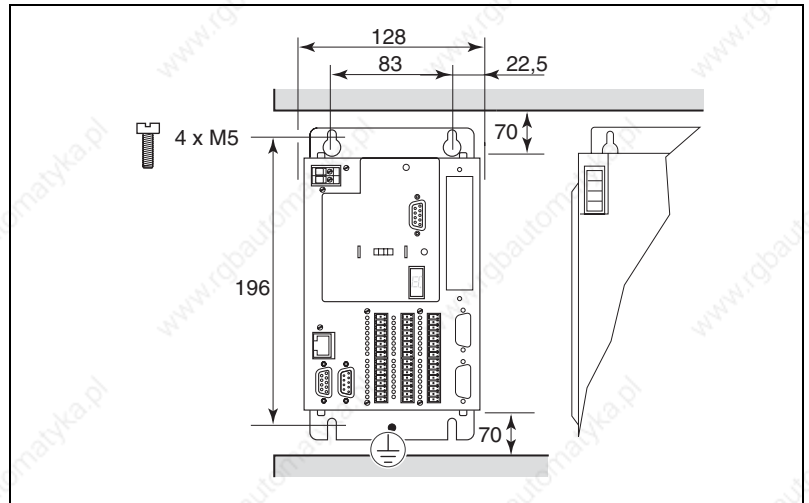

Installation clearances, dimensions in mm

Order data

Designation	Description	Order number
TLM2	TLM 271TCNA4PE version 3	0086505000106
TLM2 with Profibus-DP slave interface	TLM 271TCPA4PE version 3 with Profibus slave	0086505000105

Accessories

Designation	Description	Order number
Encoder adapter cable ACC2RKBBDE003	15-pin sub-D female, 9-pin sub-D male 0.3 m	0086300901000
TLCC/TLM connector set ACC3CS004NNNN	Scope of delivery: <ul style="list-style-type: none"> • 1 sub-D adapter with CAN terminating resistor • 6 plug connectors 	0086300901002
CD-ROM with programming software ACC4PACDS0001XX	The CD-ROM contains: <ul style="list-style-type: none"> • Installation files • Block libraries • Online help and documentation 	0062501102600

Note: Information about additional accessories can be found from page 64 onwards



SMC Smart Motion Controller

Product description

Introduction

The SMC is a Motion Controller with an integrated software PLC for performing simple motion sequences. As CANopen master, the controller can control up to 32 drives or slave devices, e.g. I/O sub-assemblies.

Application fields

- Motion and control functions for automated production cells
- Applications that require coordinated or independent movements, for example
 - Format adjustments
 - Material feed
 - Measure
 - Installation
 - Packaging manufacture
 - Pick & place
 - Check
 - Feed movements

Motion functions

- Reference movement
- Manual mode
- Point-to-point mode
- Speed mode

Programming system

All Motion Controllers described in this catalogue can be programmed using the Berger Lahr programming system in accordance with IEC 61131-3. The programming system is available on CD-ROM, see page 46. The SMC is programmed via the RS485 interface.

Features

Drive interfaces	CANopen master (max. 32 drives)
User-defined inputs/outputs	8, bidirectional
Programming and operating interface	RS232 ¹⁾
Communication via OPC	RS232 ¹⁾
Fieldbus interface (optional)	None
Berger Lahr programming system	Yes
PLCopen single-axis function blocks	Yes
PLCopen multi-axis function blocks	No
NC editors	No
Cam profile editor	No

¹⁾ The SMC has an RS485 interface. An RS485/RS232 adapter is required for connection to a PC, see SMC accessories.

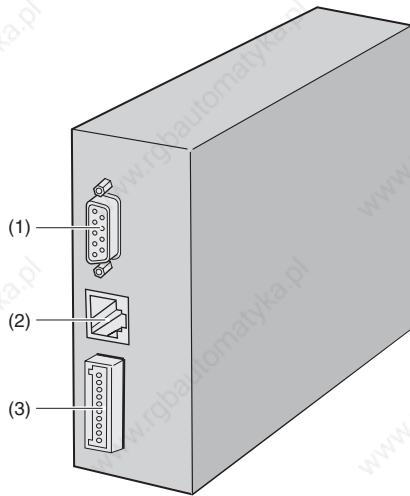

Overview of devices

- (1) CANopen interface
- (2) RS485 interface for programming control
- (3) 24 V_{DC} power supply
8 digital, bidirectional inputs/outputs

Interfaces

CANopen interface

The SMC is a CANopen master according to CiA DS 405 for communication with max. 32 drives or slave devices, e.g. I/O sub-assemblies.

RS485 interface

The RS485 interface is used for transmitting user programmes to the Motion Controller. In addition, the RS485 interface can be used as a communication interface to other devices. An RS485/RS232 adapter is available as an accessory together with the programming cable.

Inputs and Outputs

The device has eight freely useable, bidirectional inputs/outputs. Additional I/O sub-assemblies can be controlled via CANopen.

Technical data		
Electrical data		
Electrical power supply		
Voltage range	V _{DC}	20 ... 28
Nominal supply voltage	V _{DC}	24
Nominal value of current consumption	mA	80
Minimum current consumption	mA	70
RS-485 interface		
Baud rate	baud	≤115.200
CANopen fieldbus interface		
Transfer rate	kbit/s	125 / 250 / 500 / 1000
Max. number of slaves		32
Digital inputs		
Debounce time	µs	200
Max. switching threshold low -> high	V _{DC}	12 ... 24
Max. switching threshold high -> low	V _{DC}	≤5
Input resistance (pull-down to VM)	kΩ	3.1 ±0.5
Limit frequency counter input	kHz	5
Max. cable length with 0.25 mm ² wire cross-section	m	100
Digital outputs		
Max. output current	mA	<200
Max. output voltage	V _{DC}	28
Max. residual voltage at signal mode low	mV	200
Main memory		
of which	MB	1
for user programs	kB	312
for application data	kB	126
for non-volatile application data	kB	8
Real-time clock		
Real-time clock with resolution accurate to the second, with backup battery, read out and set by the user programme		
Program processing time		
Average processing time for 1000 lines of an IL code	µs	570
Mechanical data		
Weight	kg	0.6
Index of protection to DIN EN 60529:2000-09		IP20
Ambient conditions		
Ambient temperature	°C	0 ... 50
Transport and storage temperature	°C	-40 ... +70
Rel. humidity	%	15 ... 85, no condensation permitted
Max. installation altitude	m above sea level	1000

Dimensional drawings

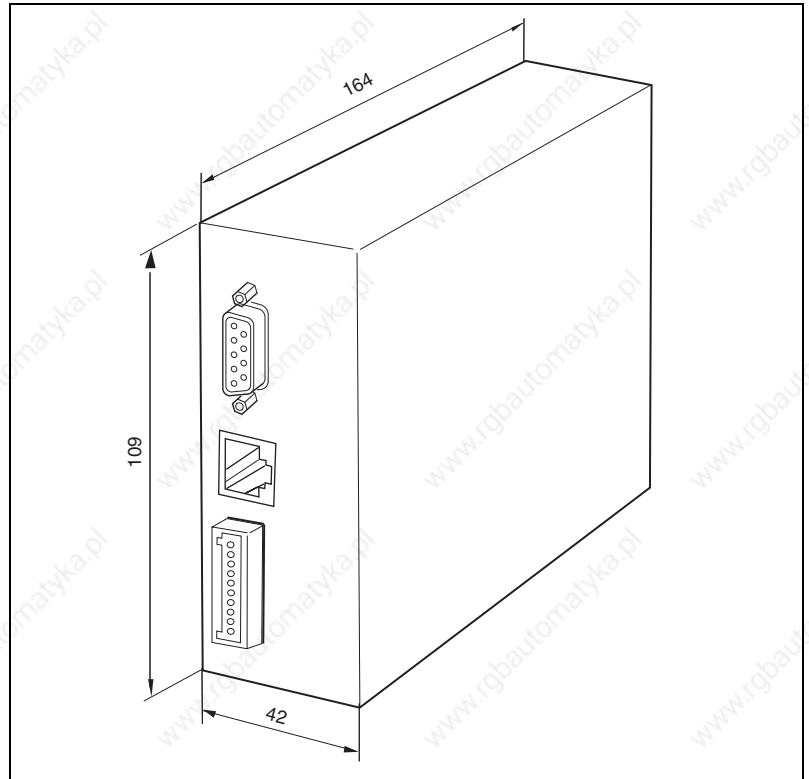

Dimensional drawing of SMC

Dimensions do not include the connectors or the top-hat rail mounting bracket

Add 20 mm to depth D for the 10-pin connection plug JP101.

14 mm must be added to the depth D or the height H for top-hat rail mounting – depending on the mounting position.

Mounting and installation

EMC-compliant installation

A low-resistance connection must be made between the SMC and protective earth (PE) in order to comply with the EMC Directive.

There is a pin for the protective conductor connection on the front of the SMC. This pin is an M4 threaded pin with a length of 20 mm.

Mechanical installation

The SMC is mounted on a top-hat rail. A bracket for top-rail mounting is supplied for this purpose. The mounting position can be selected as required. There are no minimum clearance requirements.

Order data

Designation	Description	Order number
Smart Motion Controller SMC SMC120NCNNB8D	Scope of delivery: <ul style="list-style-type: none"> • 1 Smart Motion Controller SMC • 1 matching connector for JP101 • 1 top-hat rail section including 2 screws • Installation instructions 	0086200227001

Accessories

Designation	Description	Order number
Programming cable with RS232/RS485 adapter SMC129CPB003	Scope of delivery: <ul style="list-style-type: none"> • RS232/RS485 adapter: RS232 with 9-pin sub-D connector RS485 with RJ45 connector • Programming cable 3 m 	0086300901001
CD-ROM with programming software ACC4PACDS0001XX	The CD-ROM contains: <ul style="list-style-type: none"> • Installation files • Block libraries • Online help and documentation 	0062501102600



TLC6 Motion Controller with drive

Product description

Introduction

TLC6• are adaptable single-axis Motion Controllers with integrated drive boosters for 3-phase stepper motors (TLC61) or AC synchronous servomotors (TLC63). The Motion Controllers function as intelligent actuators in an automation system. The TLC61 Motion Controller for 3-phase stepper motors is available in two power classes up to 750 W. The TLC63 Motion Controller for AC synchronous servomotors is available in four power classes up to 8 kW. The electrical connections and range of functions are identical.

The TLC6• controllers are available with two degrees of protection:

- IP20 for use in a control cabinet
- IP54, category 2, for use without a control cabinet, close to the motor

Application fields

- Single-axis positioning movements
- Control of a motor movement with simultaneous monitoring and control of sequences
- Cyclical processing of the inputs and outputs in parallel with the axis movement
- Configuration of motion sequences
- Movements coupled to external events and synchronized accordingly

Motion functions

- Reference movement
- Manual movement
- Point-to-point mode
- Speed mode
- Teach-in of position values
- Cam index gear
- Electronic gear
- Oscillator mode
- Safety functions

Programming system

All Motion Controllers described in this catalogue can be programmed using the Berger Lahr programming system in accordance with IEC 61131-3. The programming system is available on CD-ROM, see page 46.

The TLC6 is programmed via the RS232 interface

Operation

Operation is performed via:

- pluggable Twin Line HMI (Human Machine Interface) operating unit
- Twin Line CT (Control Tool) operating software
- Higher-level control system

Features

Drive interfaces	Connection for stepper motor (TLC61) or AC servomotor (TLC63) and CANopen master (max. 126 drives)
User-defined inputs/outputs	14 / 5
Programming and operating interface	RS-232
Communication via OPC	RS-232
Fieldbus interface (optional)	Profibus-DP slave, CANopen slave, Modbus, RS485
Berger Lahr programming system	Yes
PLCopen single-axis function blocks	Yes
PLCopen multi-axis function blocks	Yes
NC editors	No
Cam profile editor	Yes, additional tool

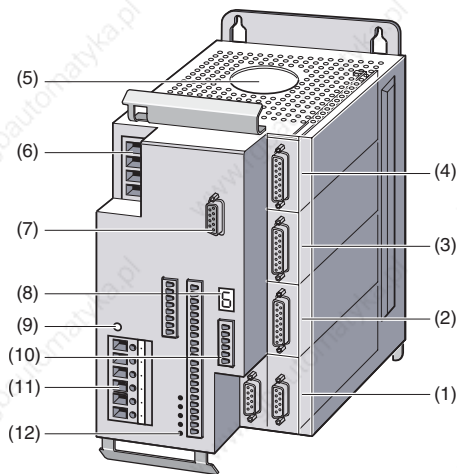

Overview of devices

- (1) Module slot M4 for communication; for the micro-modules:
 - CAN-C (can be configured as CANopen DS402 or DeviceNet)
 - IBS-C (Interbus)
 - MODB-C (can be configured as Modbus ASCII or Modbus RTU)
 - PBDP-C (Profibus-DP)
 - RS-485
- (2) Module slot M3 for encoder simulation; for the micro-modules:
 - ESIM3-C (encoder simulation, prerequisite with TLC61: M2 (3) equipped with micro-module RM-C)
 - SAM-C (safety module, prerequisite with TLC61: M2 (3) equipped with micro-module RM-C)
- (3) Module slot M2 for motor position acquisition; for the micro-modules:
 - RM-C with TLC61 (rotation monitoring for encoder)
 - HIFA-C with TLC63 (for SinCos absolute encoder)
 - RECO-C with TLC63 (for resolver, 12 bit)
- (4) Module slot M1 for position set points; for the micro-modules:
 - IOM-C (analogue module)
 - PULSE-C (for "electronic gear" operating mode via pulse/direction signals)
 - RS422-C (for "electronic gear" operating mode via A/B signals)
- (5) Air exit
- (6) Mains connection
- (7) RS 232 interface
- (8) Status display
- (9) LED for DC bus voltage
- (10) Signal interface
- (11) DC bus and motor connection
- (12) 5 LEDs for operating signals

Interfaces

Motor connection

The motor connection is short-circuit protected and is tested for earth fault at the power amplifier enable.

Electrical power supply

The supply voltage for the power amplifier is connected at the mains connection. TLC6• controllers with built-in mains filter can be operated without further interference suppression measures on the mains side.

The power supply for the electronics and fan control must be provided via an external 24 V_{DC} power supply.

RS 232 interface

The RS232 interface is a communication interface of the TLC61 for connecting a PC or the HMI hand-held operating unit.

Signal interface

The signal interface of the TLC6 has 14 freely useable inputs and 5 freely useable outputs. In addition, an analogue signal can be supplied via a ± 10 V input.

Micro-modules (optional)**IOM-C input and output module**

The IOM-C analogue module records and generates analogue and digital voltage values. The analogue outputs can be set by the user. The IOM-C micro-module expands the functions of the Motion Controller with two analogue and two digital inputs/outputs.

RS422-C for "electronic gear" via A/B signals

The RS422-C encoder module records encoder signals that are supplied as A/B signals. In addition, the index pulse is recorded and evaluated. The "electronic gear" operating mode is a typical application.

PULSE-C for "electronic gear" via pulse/direction signals

The PULSE-C module records the positioning data as a pulse/direction signal or a pulse forward/pulse backward signal. The "electronic gear" operating mode is a typical application.

RM-C for connecting an encoder for rotation monitoring (only with TLC61)

The RM-C module detects the position deviations of a stepper motor movement. The actual position signaled by the rotary encoder is compared to the nominal position. A tracking error is signaled if the deviation exceeds a defined value.

HIFA-C for connecting a SinCos absolute encoder (only with TLC63)

The HIFA-C module records the motor position of AC synchronous servomotors that are equipped with a SinCos® absolute encoder.

In the motor, the position of the rotor is detected optically and transferred to the HIFA-C module as analogue and digital position data. The module resolves the signals with 14 bit accuracy, corresponding to 16384 pulses/revolution. The absolute encoder integrated in the motor can be configured as a single-turn or multi-turn encoder. The multi-turn encoder has its absolute position within 4096 revolutions after being switched on. In addition to the motor position data, the motor parameter set (electronic motor type plate) from the SinCos® memory is transferred to the HIFA-C module via the integrated RS485 interface.

RESO-C for connecting a resolver (only with TLC63)

Resolver connection for position response of the motor position to the controller. The controller sends an exciter voltage to the resolver. Depending on the rotor position, the amplitude of the signal is modulated and sent back to the controller as a sine/cosine signal. The resolver module resolves the signals with 12-bit accuracy into a digital A/B signal.

The RESO-C module can only be used with resolvers that record a revolution with the absolute method. The transformation ratio of the resolver must be 0.5 ± 0.005 .

ESIM3-C for encoder simulator

The ESIM3-C module outputs the position data of the motor in form of incremental signals on a 15-pin sub-D socket. The incremental signals are two signals with a 90° electrical phase shift (A/B tracks).

The transmitted resolution can be set between 125 and 4000 increments per revolution, no index pulse is available. Prerequisite with TLC61: The M2 slot must have the RM-C module fitted in order for this module to be used.

A typical application for this module includes following axes in "electronic gear" operating mode.

RS485-C for serial data exchange

The RS485-C module is an asynchronous 4-wire interface with RS485 level. The module provides a short-circuit protected voltage to supply the Berger Lahr MP923 interface converter (RS232 to RS485).

MODB-C for connection to ModBus

The MODB-C is an asynchronous 4-wire interface with RS485 level. The user can configure ModBus ASCII or ModBus RTU alternatively.

PBDP-C for connection to Profibus-DP

The PBDP-C module uses the Profibus-DP as a fast cyclical communication bus. The module has a 2-wire interface with RS485 level.

CAN-C for connection to CAN bus

The CAN-C module works via the CAN bus. The CAN bus is a serial sensor/actuator bus. The module has a 2-wire connection for the CAN low and CAN high cables. The user can configure additional profiles alternatively: Berger Lahr profile, CANopen DS402 profile and DeviceNet.

IBS-C for connection to Interbus-S

The IBS-C module works via the Interbus. The Interbus is a sensor/actuator bus that operates according to the shift register principle.

SAM-C safety module

The SAM-C Safety Monitor Module adds integrated safety functions to the Motion Controller for protection of personnel, e.g. by safe operation stop and reduced speed. Prerequisite with TLC61: The M2 slot must have the RM-C module fitted in order for this module to be used.

Technical data of TLC61			
Motion Controller with drive booster for 3-phase stepper motors		TLC611	TLC612
Electrical data			
Mains connection			
Mains voltage not variable, mains filter integrated	V _{AC}	230 -20% ... 230 +15%	
Mains voltage, variable, without mains filter	V _{AC}	155 -20% ... 115 +15% 230 -20% ... 230 +15%	
Mains frequency	Hz	47 ... 63	
Current consumption at 230 V	A	2	5
Current consumption at 115 V	A	4	10
Inrush current	A	<60	
Fuse protection, external in 230 V	A	10 (C or K-characteristic or similar)	
Fuse protection, external in 230 V	A	10 (C or K-characteristic or similar)	
Motor connection			
Nominal power at nominal current	kW _{rms}	0.35	0.75
Rated current	A _{rms}	3	7
Switching frequency	kHz	16	
Max. speed of rotation	rpm	3000	
Motor cables			
Cable length	m	≤20 (standard, >20 m on request)	
Shield connection		On both sides	
Cross-section	mm ²	1.5	
24-V_{DC} system supply voltage			
Voltage range of the input	V	20 ... 30	
Ripple of the input	V _{SS}	<2	
Input current of the outputs without load	A	<2.5	
Digital inputs			
		Reverse polarity protection, no electrical isolation	
Number of inputs		18, of which 14 can be used as required	
Debounce time	μs	700 ... 1500	
Max. switching threshold low -> high	V _{DC}	12 ... 30 (I ≥3 mA)	
Max. switching threshold high -> low	V _{DC}	≤5 (I ≤0.5 mA)	
Current	mA	≤7 at 24 V	
Digital outputs			
		Short-circuit protected	
Number of outputs		7, of which 5 can be used as required	
Inductive load capacity	mH/W	150/11	
Max. output voltage	V _{DC}	30	
Max. output current	mA	400	
Voltage drop at 400 mA	V _{DC}	≤1	
analogue signal input			
Voltage range	V	-10 ... +10	
Input resistance	kΩ	5	
Resolution	bit	10	
Main memory available for use by the user programme			
Non-volatile memory for the user programme	kB	256	
Non-volatile memory for data (flash PROM)	kB	8	
Non-volatile memory for power fail data (retain)	kB	100	
Volatile memory for data	kB	128	
Mechanical data			
Weight	kg	2.7 (IP20) 8.0 (IP54)	
Degree of protection according to DIN EN 60529: 1991		IP20 (TLC6**) IP54 (TLC6*P)	
Ambient conditions			
Ambient temperature	°C	0 ... +45	
Transport and storage temperature	°C	-40 ... +70	
Rel. humidity	%	15 ... 85, no condensation permitted	
Installation altitude without derating	m above sea level	<1000	
UL-508C approval		The limit values are listed in the device documentation.	

Technical data TLC63

Motion Controller with drive booster for AC synchronous servomotors		TLC632	TLC634	TLC636	TLC638
Electrical data					
Mains connection					
Mains voltage	V _{AC}	230 -20% ... 240 +10% ¹⁾	230 -20% ... 480 +10%		
Number of mains phases		1	3		
Mains frequency	Hz	47 ... 63			
Current consumption	A	6.5	4	7.5	20
Inrush current	A	<60			
Fuse protection, external (B characteristics)	A	10	25		
Motor connection					
Nominal power at nominal current (230 V/1 or 400 V/3)	kW _{rms}	0.75	1.5	3	8
Nominal current rms value	A _{rms}	3	3	6	16
Nominal current amplitude value	A _S	4.24	4.24	8.48	22.63
Peak current for max. 5 s	A _S	11.31	11.31	28.28	45.26
Switching frequency	kHz	8/16		4/8	
Max. speed of rotation	rpm	12000			
Motor cables					
Cable length	m	≤20 (standard, >20 on request)			
Shield connection		On both sides			
Cross-section length-dependent	mm ²	1.5	1.5 ... 2.5		4
DC bus connection		Max. two devices in the same power class can be connected in parallel			
Internal ballast circuit					
Sustained power	W	60	100	200	80
Max. energy per braking procedure	Ws	350	600	100	130
24 VDC system supply voltage					
Input voltage range	V	20 ... 30			
Input ripple	V _{SS}	<2			
Input current of the outputs without load	A	<2.5			
Digital inputs					
		Reverse polarity protection, no electrical isolation			
Number of inputs		18, of which 14 can be used as required			
Debounce time	ms	0,7 ... 1,5			
DC voltage U _{high}	V	12 ... 30 (I ≥ 3 mA)			
DC voltage U _{low}	V	≤5 (I ≤ 0.5 mA)			
Current	mA	≤7 at 24 V			
Digital outputs					
		Short-circuit protected			
Number of outputs		7, of which 5 can be used as required			
Accepts inductive load	mH/W	150/11			
DC voltage	V	≤30			
Switching current	mA	≤400			
Voltage drop at 400 mA	V	≤1			
analogue signal input					
Voltage range	V	-10 ... +10			
Input resistance	kΩ	5			
Resolution	bit	10			
Main memory available for use by the user programme					
Non-volatile memory for the user programme	kB	256			
Non-volatile memory for data (flash PROM)	kB	8			
Non-volatile memory for power fail data (retain)	kB	100			
Volatile memory for data	kB	128			
Mechanical data					
Weight	kg	2.7 (IP20), 8.0 (IP54)			
Degree of protection according to DIN EN 60529: 1991		IP20 (TLC6**), IP54 (TLC6*P)			
Ambient conditions					
Ambient temperature	°C	0 ... +50			
Transport and storage temperature	°C	-40 ... +70			
Rel. humidity ²⁾	%	15 ... 85			
Installation altitude without derating	m above sea level	<1000			
UL-508C approval		The limit values are listed in the device documentation			

¹⁾ Optional 115 V -20% ... 115 V +10%

²⁾ No condensation permitted

Technical data of micro-modules (optional)		
IOM-C		
Number of inputs/outputs		2 inputs each / 2 A
Digital signal inputs		Reverse polarity protection, no electrical isolation, debounced
• DC voltage U_{high}	V	12 ... 30
• DC voltage U_{low}	V	<5
• Current at 24 V	mA	<7
• Debounce time	ms	0.7 ... 1.5
Digital signal outputs		Accepts inductive load 50 mH, short-circuit protected, reverse polarity protection
• DC voltage	V	12 ... 30
• Inhibit current	μ A	<100
• Switching current	mA	<50
• Voltage drop at 50 mA	V	≤ 2
Analogue signal inputs		
• Voltage range	V	-10 ... +10
• Input resistance	k Ω	50
• Resolution	bit	10
Analogue signal outputs		
• Voltage range	V	-10 ... +10
• Max. output current	mA	5
• Resolution	bit	12
RS422-C		
Inputs		RS422 voltage-compatible, electrically connected with 24 V _{GND}
• Input frequency	kHz	≤ 400
Outputs		
• Supply of the control rotary encoder		5 V $\pm 5\%$, 300 mA max. SENSE control, short-circuit protected, protected against overload
Signal cable		
• Max. length	m	100
• Minimum cross-section	mm ²	0.5 (supply voltage 5 V _{DC} and 5 V _{GND}) 0.25 (for other signals)
PULSE-C		
Inputs		
• Control		Symmetrical RS422; asymmetrical 4.5 ... 30 V; electrically connected with 24 V _{GND}
• Input resistance	k Ω	5
• Input frequency of the pulse signals	kHz	≤ 200
• Input frequency ENABLE	kHz	≤ 1
Outputs		Open collector, short-circuit protected
• Output voltage	V	≤ 30
• Output current	mA	≤ 50
Signal cable		
• Max. length with RS422 connection	m	100
• Max. length with open collector connection	m	10
• Minimum cross-section of the signal conductors	mm ²	0.14
RM-C (only with TLC 61)		
Signal inputs (A, B)		RS422 level, electrically connected with 24 V _{GND}
• Input frequencies	kHz	≤ 400
	Inc/s	160000
• Resolution of the rotary encoder	Marks	1000
Rotary encoder supply output (SENSE)		SENSE control, short-circuit protected and with overload protection
• Output voltage	V	5 $\pm 5\%$
• Output current	mA	≤ 300
HIFA-C (only with TLC 63)		
Supply voltage, output for encoder		+10 V / 150 mA, short-circuit protected, with overload protection, not protected against interference voltage
Signal inputs		
• Sine/cosine (SIN, COS)	V _{SS}	1 with 2.5 V offset, 0.5 with 100 kHz
• Input resistance against GND	k Ω	2 x 1
• Monitoring of motor temperature (T_MOT)		NTC / PTC
RS-485		Asynchronous, half-duplex

Technical data of micro-modules (optional)

RESO-C (only with TLC 63)		
Exciter voltage output		3.5 V _{rms} ±10%, 60 mA max., short-circuit protected, protected against overload, not protected against interference voltage
Exciter frequencies ¹⁾	kHz	3.5 / 5 / 6.5 / 10 ±20%
Monitoring of motor temperature (T_MOT)		NTC / PTC
Sine/cosine inputs		Symmetrical with GND
• Input resistance	kΩ	2.15
• Input voltage	V _{rms}	1.75 ±10%
ESIM3-C		
Digital signal outputs A/B		RS422 voltage-compatible, electrically connected with 24 V _{GND}
RS485-C		
Transmission rates	kbaud	1200 / 2400 / 4800 / 9600 / 19200 / 38400
Supply voltage output	V	+12 (9 ... 15 V)
MODB-C		
Transmission rates	kbaud	1200 / 2400 / 4800 / 9600 / 19200
Supply voltage output	V	+12 (9 ... 15 V)
PBDP-C		
Max. transmission rate	Mbaud	12
Supply voltage output	V	+5 (max. 10 mA), only for terminating resistor
Max. cable length to next station	m	400
CAN-C		
Max. transmission rate	Mbaud	≤1, adjustable
Max. cable length		
• At 125 kbaud	m	500
• At 500 kbaud	m	100
Level CAN-L/CAN-H		According to ISO 11898
Terminating resistor on both ends	Ω	120
IBS-C		
Transfer rate	kbaud	500
Max. cable length to next station	m	400
SAM-C		
24 V _{DC} supply voltage		PELV, DIN 19240, reverse polarity protection
• Input voltage range	V	20 ... 30
• Input ripple	V _{SS}	<2
• Input current of the outputs without load	A	<0.02
Digital signal inputs		
• Time window for simultaneous switching of both signals of a switching pair	s	10
• DC voltage U _{high}	V	15 ... 30 (I ≥ 3 mA)
• DC voltage U _{low}	V	≤5 (I ≤ 0.5 mA)
• Current at 24 V (5 kΩ against GND)	mA	≤0.5
• Debounce time	ms	>1
Digital signal outputs		
		Accepts inductive load (150 mH / 11 W), accepts capacity load (C ≤ 1 μF), short-circuit protected
• DC voltage	V	≤30
• Switching current RELAY_A, RELAY_B, INTERLOCK-OUT	A	≤0.5
• Switching current SAFETY24VDC-A, SAFETY24VDC-B	A	≤0.3
• Switching current AUXOUT-1, AUXOUT-2	A	≤0.1

¹⁾ can be programmed with parameters

Dimensional drawings

TLC61• (IP20 + IP54)

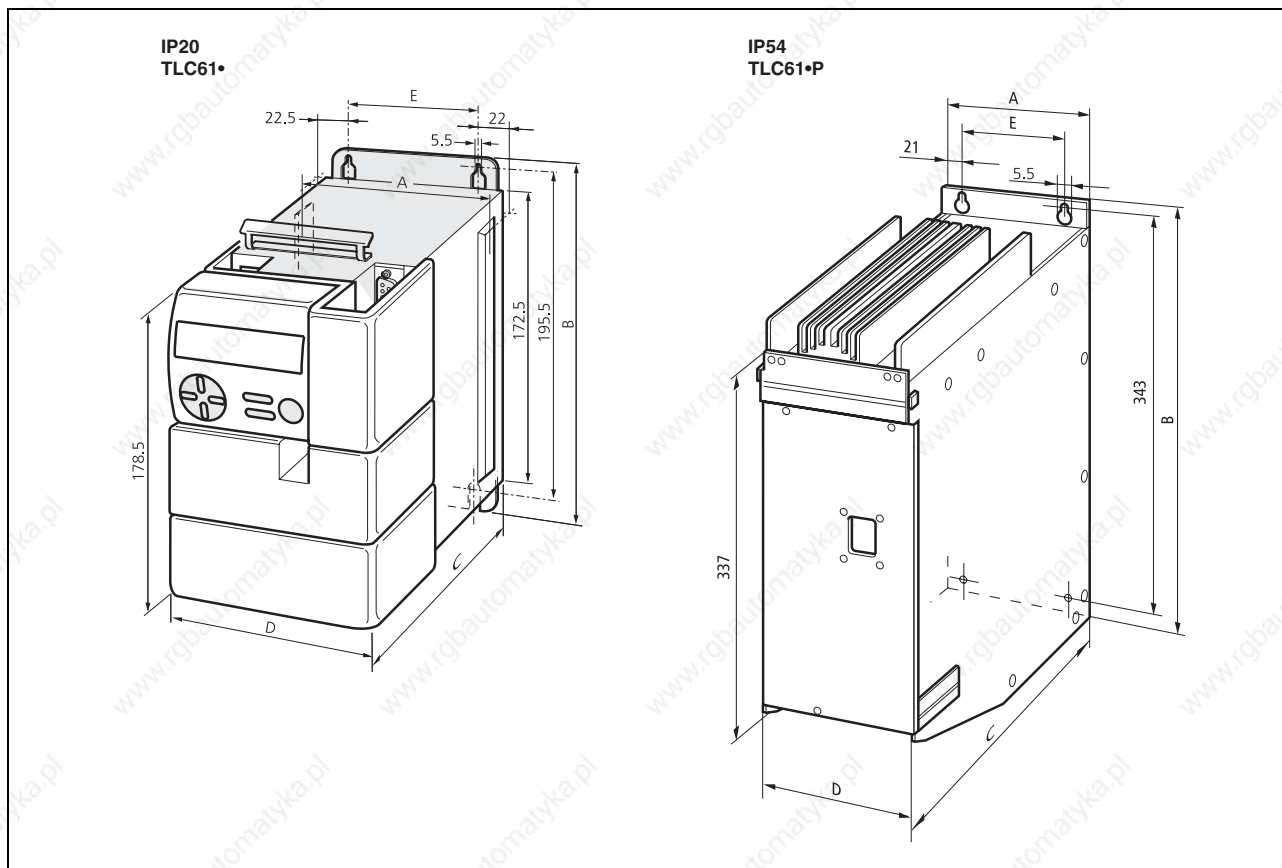

Dimensional drawing of Motion Controllers TLC61• (IP20) and TLC61•P (IP54)

	TLC61•	TLC61•P
Width A [mm]	108	127
Height B [mm]	212.5	360
Depth C [mm]	184.5	245
Front width D [mm]	105.5	127
Connection dimension E [mm]	63	80

Dimensional drawings

TLC63• (IP20)

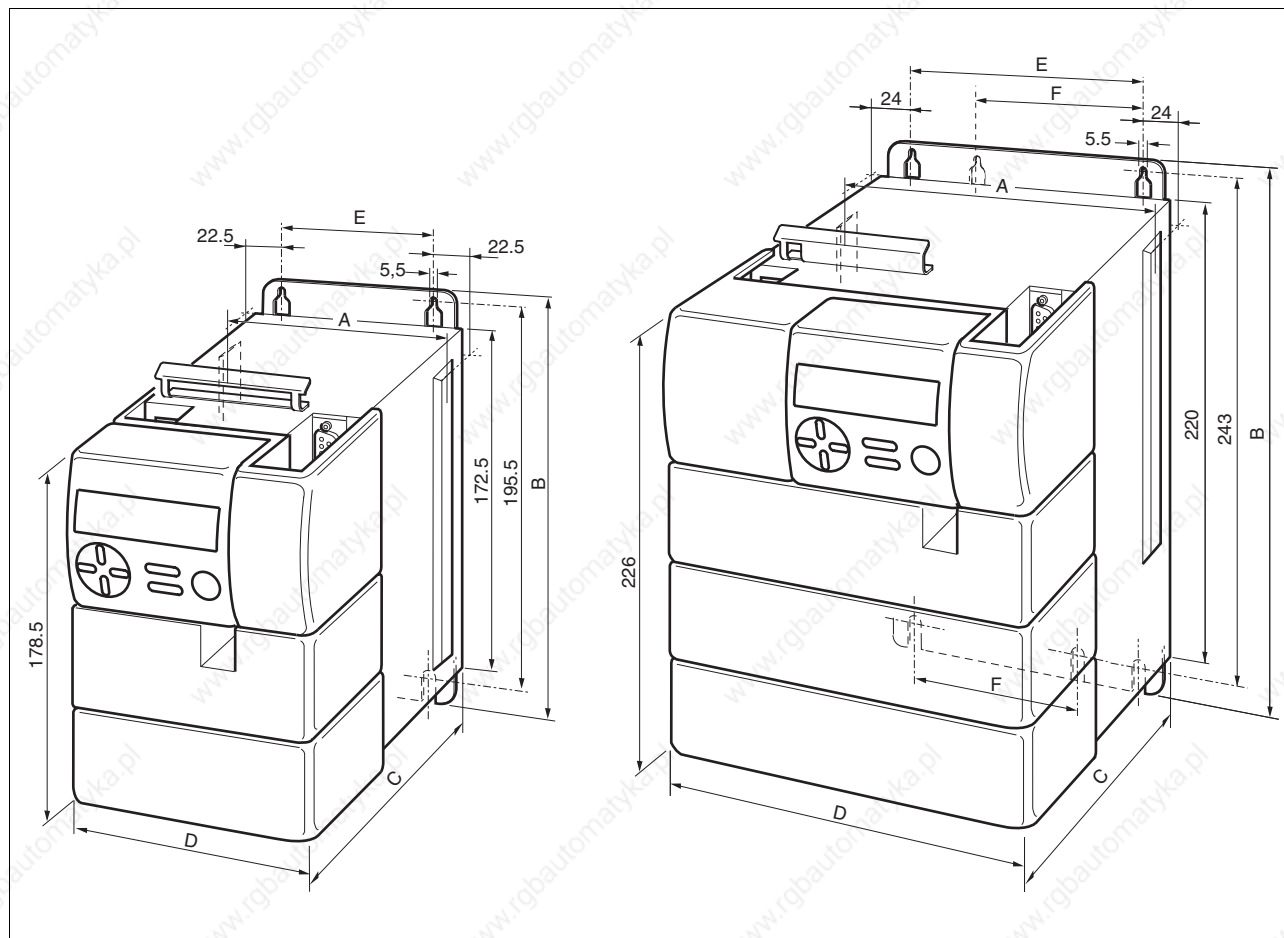

Dimensional drawing of TLC63• (IP20)

	TLC632	TLC634	TLC636	TLC638
Width A [mm]	108	128	178	248
Height B [mm]	212.5	212.5	260	260
Depth C [mm]	184.5	214.5	244.5	244.5
Front width D [mm]	105.5	125.5	176	246
Connection dimension E [mm]	63	83	130	200
Additional dimension F [mm]	-	-	-	120

Dimensional drawings

TLC63•P (IP54)

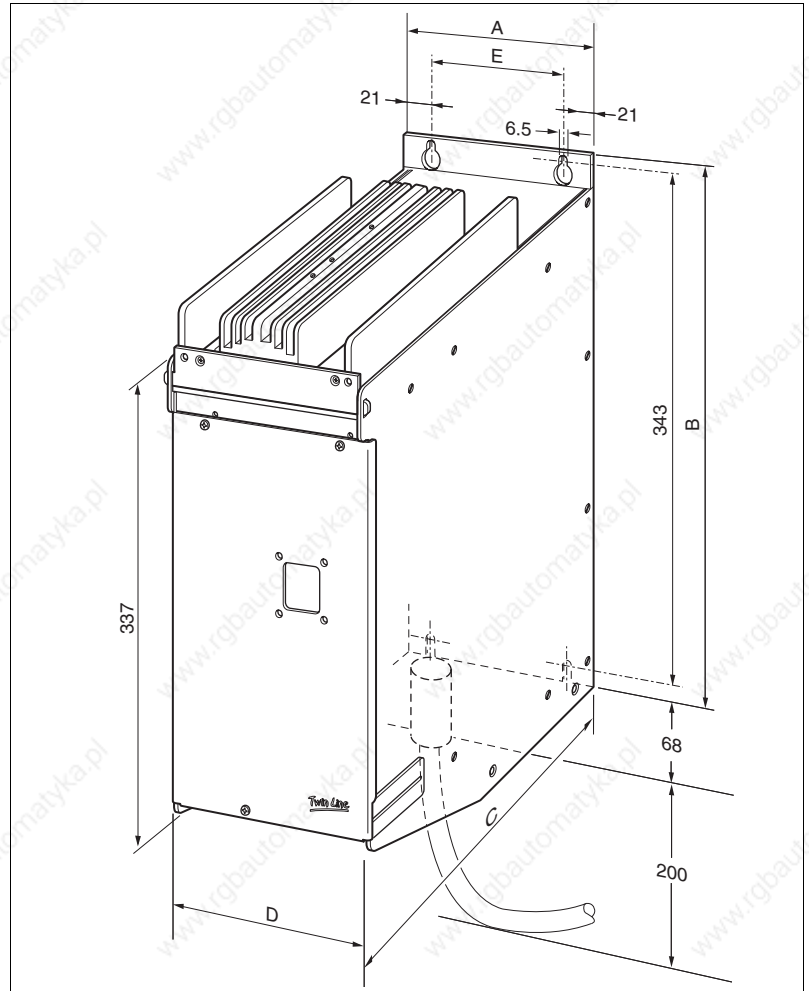

Dimensional drawing of TLC63•P (IP54)

	TLC632P	TLC634P
Width A [mm]	127	147
Height B [mm]	360	360
Depth C [mm]	245	275
Front width D [mm]	127	127
Connection dimension E [mm]	80	100

Mounting and installation

EMC-compliant installation

TLC6 Motion Controllers satisfy the EMC requirements for the second environment according to IEC 61800-3.

EMC-installation is essential for compliance with the specified limit values. Better results can be achieved using the following measures, depending on the application:

- Connecting mains reactors ahead in series, specifications for current harmonics are available on request.
- Connecting mains filter ahead in series, in particular to comply with limit values for the first environment (living area, category C2).
- Particularly EMC-compliant installation, e.g. in an enclosed control cabinet with 15 dB attenuation of the emitted radiation.

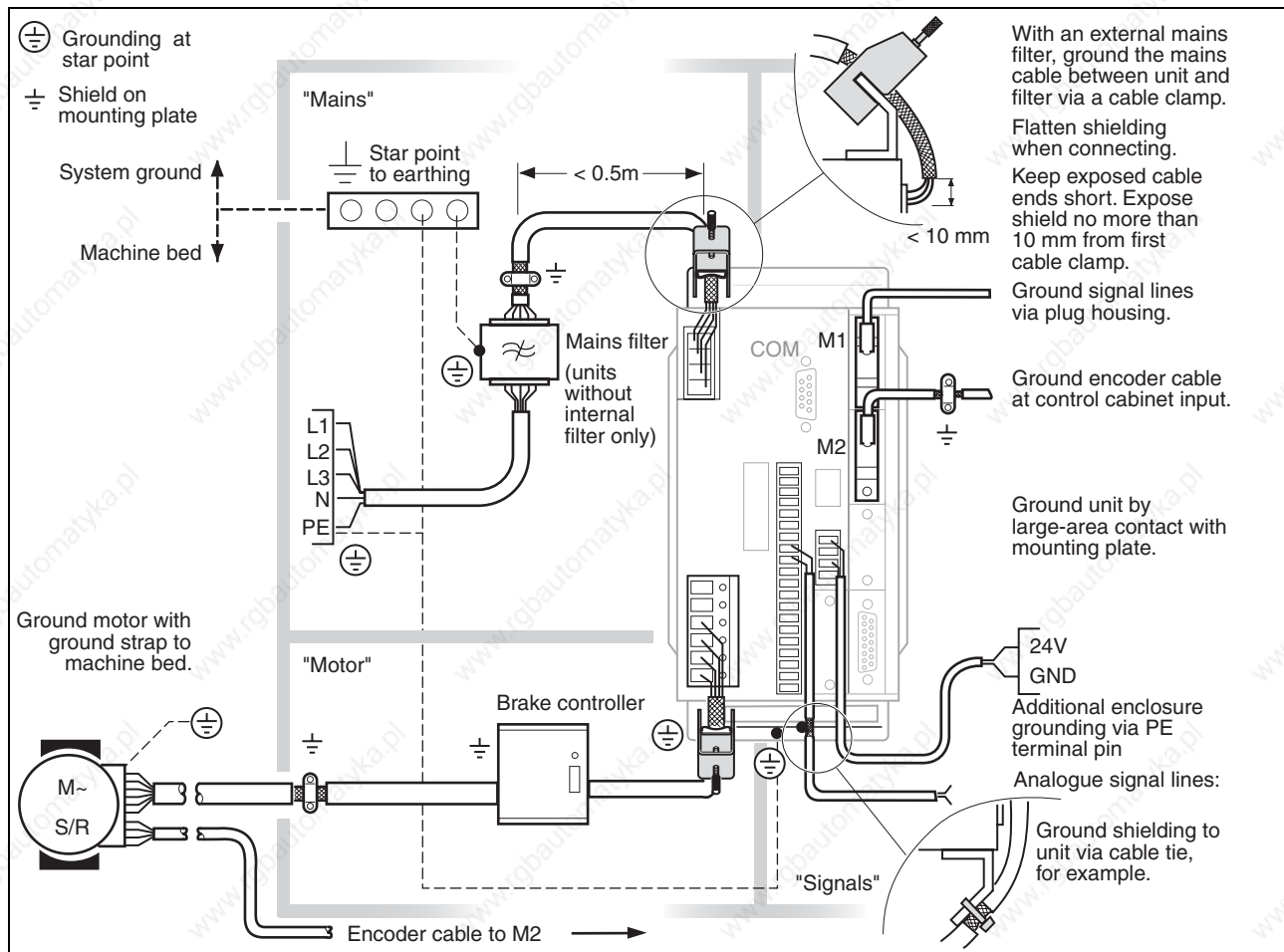

EMC measures and sub-division of the control cabinet

Mechanical installation

Installation in the control cabinet

Motion Controllers and accessories such as ballast resistor and holding brake controllers must be securely mounted in the control cabinet and wired up in accordance with EMC regulations.

The control cabinet ventilation must be capable of evacuating the heat losses by the Motion Controller and its components as well as the ballast resistors.

Installation clearances

The Motion Controller is equipped with a fan. The ventilation openings must be kept clear to a distance of 70 mm at all times.

The connections of the Motion Controller are located on the bottom of the housing. A space of 20 cm must be left under the Motion Controller so that the connections can be routed without kinking.

There is a ventilation element on the underside. Do not remove the protective flap. The Motion Controller must be installed vertically in order to guarantee protection against water.

TLC61• (IP20)

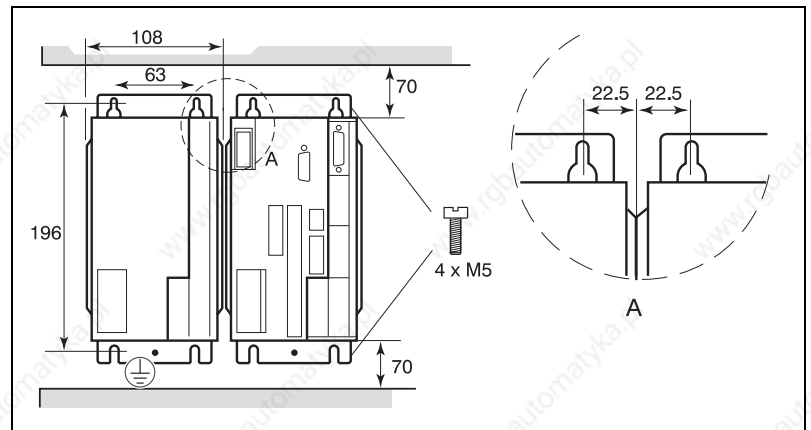

Installation clearances of TLC61 (IP20), dimensions in mm

TLC61•P (IP54)

The Motion Controller in the P version (IP54) must be mounted with a minimum clearance of 10 mm from adjacent devices.

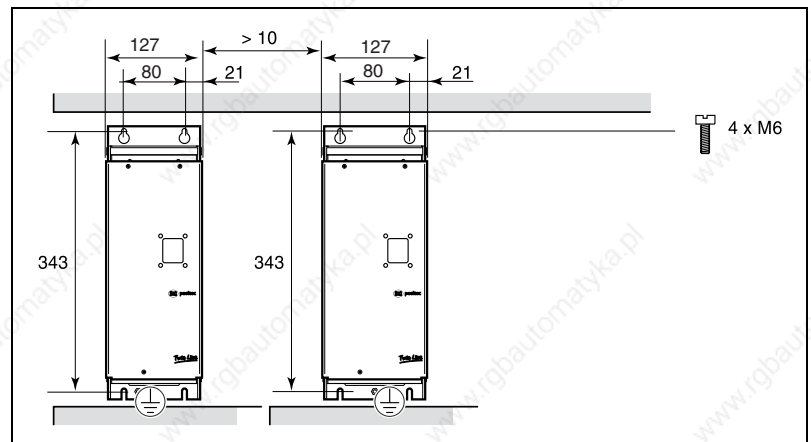

Installation clearances of TLC61P (IP54), dimensions in mm

TLC63•

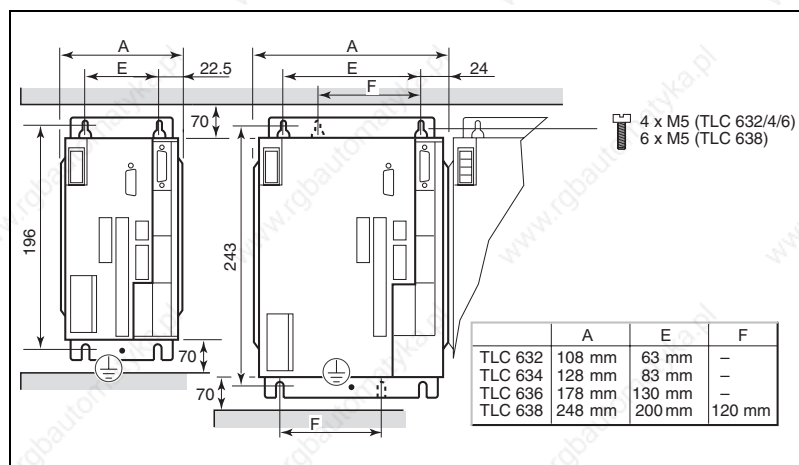

Installation clearances of TLC63 with degree of protection (IP20), dimensions in mm

TLC63•P

The TLC63 •P Motion Controller must be installed with a minimum clearance of 10 mm from adjacent devices.

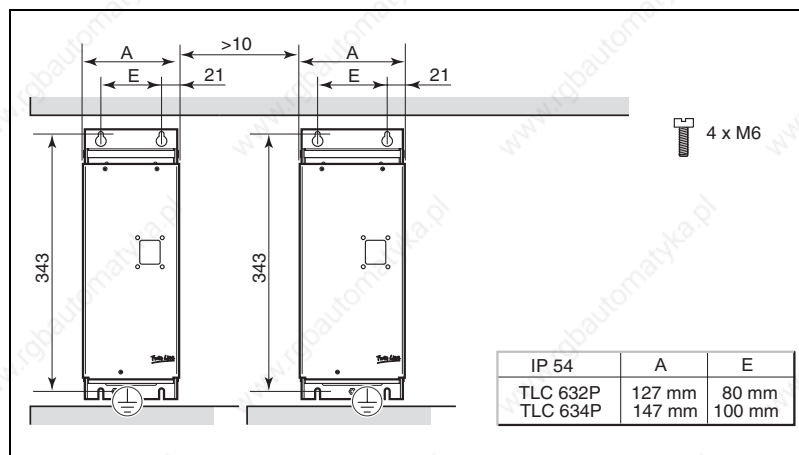

Installation clearances of TLC63P with degree of protection (IP54), dimensions in mm

Options for TLC6•P with degree of protection IP54

Integrated holding brake controller

Motion Controllers with degree of protection IP54 can be configured with a holding brake controller HBC (**H**olding **B**rake **C**ontroller) in addition to the micro-modules. The integrated holding brake controller boosts the brake signal of the signal interface and activates the holding brake so that it closes quickly and generates as little heat as possible. When the power amplifier is enabled, the holding brake is automatically released and it is automatically applied when the power amplifier is switched off. The connection for holding brake activation is on the underside of the housing.

Passage grommets

The cables and connectors are passed through the housing. A set of passage grommets is available as an option in order to achieve degree of protection IP54.

Clamping bracket

A clamping bracket with top-hat rail TS 15 for a snap-on mini-modular terminal block with max. 1.5 mm cross-section is optionally available in order to permit additional wiring and possibly to dispense with external terminal boxes. The clamping bracket is installed inside the Motion Controller housing.

Please refer to the Twin Line accessories catalogue for information and technical data about available accessories

Order data of TLC6• (IP20)

Type code (example):	TLC	6	1	1	F	IOM	RM	–	MODB
Product family TLC = Twin Line Controller	TLC	6	1	1	F	IOM	RM	–	MODB
Device function 6 = programmable according to IEC 61131-3	TLC	6	1	1	F	IOM	RM	–	MODB
Drive booster 1 = for stepper motors 3 = for AC synchronous servomotors	TLC	6	1	1	F	IOM	RM	–	MODB
Nominal power 1 = 350 W (TLC61 only) 2 = 750 W (TLC61 and TLC63) 4 = 1500 W (TLC63 only) 6 = 3000 W (TLC63 only) 8 = 8000 W (TLC63 only)	TLC	6	1	1	F	IOM	RM	–	MODB
Mains filter F = with built-in mains filter, 230 V _{AC} NF = without mains filter, 230 V _{AC} (with TLC61: 115 V / 230 VAC, can be switched over) LV = without mains filter, 115 V _{AC} (only possible with TLC632)	TLC	6	1	1	F	IOM	RM	–	MODB
Position set points on module slot M1 – = not connected IOM = I/O module (2 analogue and digital inputs/outputs each) PULSE = for electronic gear, P/R or P _V /P _R signals RS422 = for electronic gear, A/B signals	TLC	6	1	1	F	IOM	RM	–	MODB
Motor position acquisition on module slot M2 – = not connected RM = rotation monitoring encoder, 1000 marks (TLC61 only) HIFA = SinCos = absolute encoder single or multi-turn (TLC63 only) RESO = resolver, 12 bit evaluation (TLC63 only)	TLC	6	1	1	F	IOM	RM	–	MODB
Encoder simulation on module slot M3 – = not connected ESIM3 = encoder simulation SAM = safety module	TLC	6	1	1	F	IOM	RM	–	MODB
Communication on module slot M4 – = not connected CAN = CAN bus IBS = Interbus MODB = Modbus ASCII or Modbus RTP can be configured PBDP = Profibus-DP RS485 = RS485 ESIM1 = encoder simulation, 1 signal connection, A/B signals ESIM2 = encoder simulation, 2 signal connections, A/B signals	TLC	6	1	1	F	IOM	RM	–	MODB

Order data for TLC6•P (IP54)												
Type code (example):	TLC	6	1	1	P	S	F	IOM	RM	-	MODB	HBC
Product family TLC = Twin Line Controller	TLC	6	1	1	P	S	F	IOM	RM	-	MODB	HBC
Device function 6 = programmable according to IEC 61131-3	TLC	6	1	1	P	S	F	IOM	RM	-	MODB	HBC
Drive booster 1 = for stepper motors 3 = for AC synchronous servomotors	TLC	6	1	1	P	S	F	IOM	RM	-	MODB	HBC
Nominal power 1 = 350 W (TLC61 only) 2 = 750 W (TLC61 and TLC63) 4 = 1500 W (TLC63 only)	TLC	6	1	1	P	S	F	IOM	RM	-	MODB	HBC
Degree of protection P = degree of protection IP54	TLC	6	1	1	P	S	F	IOM	RM	-	MODB	HBC
Mains voltage _ = 230 V _{AC} (TLC63 only) S = mains voltage can be switched between 115 / 230 V _{AC} (TLC61 only) L = 115 V _{AC} devices (TLC632 only)	TLC	6	1	1	P	S	F	IOM	RM	-	MODB	HBC
Mains filter F = with built-in mains filter	TLC	6	1	1	P	S	F	IOM	RM	-	MODB	HBC
Position set points on module slot M1 _ = not connected IOM = I/O module (2 analogue and digital inputs/outputs each) PULSE = for electronic gear, P/R or P _v /P _R signals RS422 = for electronic gear, A/B signals	TLC	6	1	1	P	S	F	IOM	RM	-	MODB	HBC
Motor position acquisition on module slot M2 _ = not connected RM = rotation monitoring for encoder, 1000 marks (TLC61 only) HIFA = absolute encoder single or multi-turn (TLC63 only) RESO = resolver, 12 bit evaluation (TLC63 only)	TLC	6	1	1	P	S	F	IOM	RM	-	MODB	HBC
Encoder simulation on module slot M3 _ = not connected ESIM3 = encoder simulation SAM = safety module	TLC	6	1	1	P	S	F	IOM	RM	-	MODB	HBC
Communication on module slot M4 _ = not connected CAN = CAN bus IBS = Interbus MODB = Modbus ASCII or Modbus RTP can be configured PBDP = Profibus-DP RS485 = RS485 ESIM1 = encoder simulation, 1 signal connection, A/B signals ESIM2 = encoder simulation, 2 signal connections, A/B signals	TLC	6	1	1	P	S	F	IOM	RM	-	MODB	HBC
Holding brake controller _ = not installed HBC = holding brake controller integrated, cannot be retrofitted	TLC	6	1	1	P	S	F	IOM	RM	-	MODB	HBC

Interfaces for communication

Ethernet

Ethernet is a hard-wired data network technology for local data networks (LAN = Local Area Network). Ethernet permits data to be exchanged in the form of data frames between all devices connected to the local data network (computers, printers, etc.). Nowadays, Ethernet technology also links devices over long distances.

The main constituents of Ethernet are:

- Definitions of cable types and connectors
- Description of signalling for bit transmission layer
- Definition of package formats and protocols

In terms of the OSI model (Open Systems Interconnections), Ethernet specifies OSI layer 1 (physical layer) and OSI layer 2 (data link layer). To a large extent, Ethernet is standardised in the IEEE standard 802.3. It became the biggest selling LAN technology in the 1990s and has displaced other LAN standards such as Token Ring, FDDI and ARCNET. For Berger Lahr, Ethernet forms the basis of the TCP/IP network protocol that permits data to be exchanged beyond local networks.

Application	FTP	SMTP	HTTP	DNS	DHCP	...
Transport	TCP			UDP		
Network	IP					ARP
Network access	Ethernet					

Ethernet in the OSI layer model

CANopen

CANopen is a communication protocol based on CAN (Controller Area Network) for the OSI layer 7 (application layer) that is chiefly used in automation engineering. CANopen has been the responsibility of the CiA Organization (CiA = CAN in Automation) since 1995 and has now been standardized in European Standard EN 50325-4. The communication protocol is based on the principle of a message distribution system and, thanks to its particular performance characteristics and the inexpensive protocol blocks, permits a wide variety of innovative system solutions.

Important properties of CANopen:

- The data transmission rate depends on the length of a network cable: 40 m at 1 Mbit/s; 1000 m at 50 kbit/s etc.
- Inexpensive twisted-pair 2-wire cable with terminating resistors
- Object-oriented messages, broad and multitasking with acceptance check
- Maximum data transmission rate 1 Mbit/s
- Very high data security (HK=6); error detection and signalling, automatic switch-off of defective stations
- Open system (ISO 11898 and CiA DS 301, DS 405)

Profibus-DP

PROFIBUS (Process Field Bus) is a recognised standard for fieldbus communication in automation engineering, and was initially promoted by the German Federal Ministry for Research and Technology.

Berger Lahr uses PROFIBUS-DP (DP = Decentralized Peripherals) because it provides many diagnostic possibilities as standard.

The most important area of application for PROFIBUS-DP is networking several controllers together (distributed intelligence). PROFIBUS permits data transmission rates of up to 12 Mbit/s on twisted 2-wire cables.

Important properties of Profibus-DP

- Maximum length of a PROFIBUS: With electrical structure up to 9.6 km, with optical structure up to 90 km
- The data transmission rate depends on the length of a network cable and the number of repeaters (signal regenerators):
- 93.75 kbit/s with 9.6 km and 7 repeaters
- 1.5 Mbit/s with 1.2 km and 4 repeaters
- 1.5 Mbit/s with 200 m without repeaters
 - 12 Mbit/s with 100 m without repeaters
- Electrical structure with shielded twisted 2-wire cable and RS485 interface
- Bus access using token passing procedure: Master forwarding in the logical token ring with subordinate master/slave access (polling); normal mode with only one master and polling.
- Maximum 32 Profibus-DP slaves on one master

Serial port

In general, serial port refers to a digital input and output of a computer or a peripheral device. Serial data transmission involves bits being sent one after the other along a single line. On the TLCC and TLM2, the RS232 interface cannot only communicate with the peripheral equipment (e.g. Magelis terminals), but also serves as a programming interface alongside Ethernet.

Important properties of RS232:

- Transmission is in words (8 databits).
- Data transmission is asynchronous.
- RS232 is a voltage interface.
- 9-pin sub-D plug and socket connection
- Data transmission in handshake

The Soft Motion Controller SMC has an RS485 serial port with RJ45 female connector. A programming cable with RS485/RS232 adapter can be ordered as an accessory item for connecting to a PC.

Pulse/direction interface

The pulse/direction interface is suitable for controlling stepper motors and servomotors. The power amplifiers are controlled according to the principle of 1 pulse = 1 step, i.e. the motor turns by precisely one increment for each voltage pulse. The direction of rotation and release of the power amplifier are handled on other cables. At the same time, the power amplifier signals operating readiness and malfunctions via the interface.

Important properties of the pulse/direction interface:

- sub-D 15-pin plug and socket connection
- Shielded cable, twisted-pair lines, minimum cross-section of the signal conductors 0.14 mm²
- Grounding of the shield on both ends
- Maximum cable length 100 m

Customer-specific interfaces

Customer-specific interface solutions are possible for the TLCC and TLM2 Motion Controllers. This means our customers can continue to use their existing control concepts. For example, the control technology can implement an intelligent gateway or multiply the aforementioned interfaces.

Programming

Run-time system TLCC_V3

The Berger Lahr run-time system TLCC_V3 has been specially developed for the TLCC and TLM2 Motion Controllers from Berger Lahr and provides the application programmer with function blocks for straightforward hardware configuration. TLCC_V3 makes it possible to develop application programmes independent of hardware and operating system.

User programmes written for the Berger Lahr TLCC Motion Controller, for example, can be run on the Berger Lahr TLM2 Motion Controller without modifications.

The run-time system TLCC_V3 from Berger Lahr is based on the run-time system CoDeSys SP. CoDeSys SP is a software layer located between the application layer and the operating system layer.

CoDeSys SP provides necessary basic functions for user programmes, for example:

- Reading and writing files
- Transporting data via networks
- Controlling input and output devices
- Handling, sorting and searching for data

CoDeSys

Application programme

Berger Lahr PLCopen-blocks

Berger Lahr run-time system TLCC_V3

IEC 61131-3

Run-time system CoDeSys SP

Real-time expansion RT-Linux

Operating system Linux

Berger Lahr Hardware

Control architecture

Technical features

- 32 different tasks with prioritization
- Handling of 32 kB retain variables
- 13 MB free flash memory
- 64 MB RAM for applications
- Handling of a CANopen stack for up to five independent CANopen masters, each with 126 stations
- Processing speed 1000 lines of IL code in 25.6 μ s

Operating system RT-Linux

Description

The operating system is the software that makes it possible to use a computer. The operating system controls hardware components such as the memory, hard disk or input/output devices. In addition, it controls the execution of programmes.

RT-Linux expands the Linux operating system into a real-time operating system. RT-Linux was originally developed by Professor Victor Yodaiken and his student Michael Barabanov at the University of New Mexico.

A real-time operating system, also referred to as RTOS (real-time operating system), is an operating system with additional real-time functions for complying with time conditions and the predictability of process behaviour.

Most applications must have real-time behaviour. The software must respond to the procedures within a defined time frame, otherwise the application does not function or the quality is unsatisfactory.

RT-Linux is excellently suited to fulfilling unusually high real-time requirements. The current limits of what is technically feasible based on Intel architecture are one or two microseconds of inaccuracy (jitter) in periodic tasks and maximum 25 microseconds response time during interrupt handling.

Linux is a freely available operating system. The source code of its core is covered by the GNU General Public License, which means it is accessible to everybody. The global availability of Linux has meant that an ever increasing number of programmers have developed the operating system into a high-performance and stable platform. Nowadays, Linux offers an extensive pool of applications, some of which are also available at no cost.

Advantages

The RT-Linux operating system offers the following advantages:

No license fees

Embedded Linux utilises the GNU toolchain. This is often available as a binary version for various platforms, and does not need to be written specially. The development environments are free and freely available.

There are no license fees for using Embedded Linux.

Simple implementation of customer-specific modifications

Often, applications can be used in a new hardware design without extensive modifications. This means customer-specific modifications can be implemented quickly.

High-performance network support

An important strength of Linux is its high-performance network support

Low risks

As a rule, there is a reference implementation (driver, communication, network) for each task in Linux that can be used for independent developments. This minimizes not only the costs but also the risks.

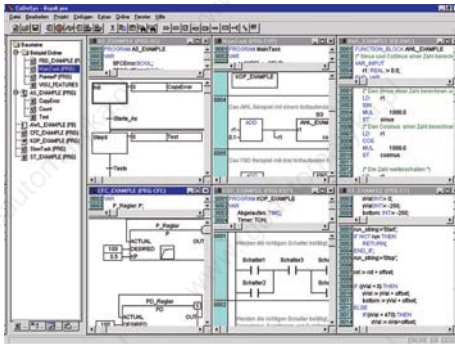

Programming system

Introduction

The Berger Lahr programming system is based on the programming software CoDeSys of the independent software company, 3S Smart Software Solutions GmbH. CoDeSys corresponds to the PLC standard IEC 61131-3. CoDeSys is one of the leading development tools for programmable automation components. More than 100 manufacturers of hardware components are now using CoDeSys for industrial automation.

Berger Lahr is expanding the basic functions of CoDeSys with a large number of function blocks. Some of the function blocks correspond to PLC open standards 1 and 2, the rest are specific developments for Berger Lahr Motion Controllers.

Advantages

Using CoDeSys as the basis for the Berger Lahr programming system offers decisive advantages for application programming:

- Non-proprietary programming of different control systems with a single tool
- Installation of only one programming environment for programming all products from the more and 100 system partners of the CoDeSys Automation Alliance
- No dependency on a single supplier
- Reduced training costs
- Continuous further development of the programming system, independently of the ongoing developments by individual hardware manufacturers

CD-ROM with programming system

The CD-ROM with the Berger Lahr programming system contains:

- CoDeSys installation files and configuration files for all Berger Lahr Motion Controllers
- Block libraries including SoftMotion and PLCopen blocks for CANopen drives from Berger Lahr as well as blocks for CANopen based on CiA DS405 for linking any CANopen devices
- Online help (German, English) for each Motion Controller and for each function block
- Documentation (PDF) for Berger Lahr Motion Controllers and drives
- CoDeSys runs on a PC with MS Windows 2000, NT and XP Professional operating system.

The online help and the documentation can be viewed without installing the programming system.

Online help

The context-sensitive online help from Berger Lahr is available to provide support throughout the programming procedure.

The online help describes the following points for each block:

- General introductory information as well as instructions that must be followed with the corresponding machine functions.
- Which blocks are required for implementation.
- All inputs and outputs as well as control signals, including declaration and value range.
- Signal diagrams as well as examples of the signal behaviour.

The screenshot shows the 'Motion I/Fx' help window. On the left is a navigation tree with categories like 'Initialisation', 'Manual movement', 'Referencing', 'Point-to-point mode', 'Velocity mode', 'Electronic Gear', 'Stop', 'Fast position capture', 'Read parameters', 'Write parameters', 'Inputs/outputs', and 'Error handling'. The 'Electronic Gear' category is selected. The main content area displays the 'MC_GearIn_IFx' block documentation, which includes a signal diagram, a 'CommandAborted' variable definition, and a detailed 'Function of the block' section.

MC_GearIn_IFx

Execute InGear
SyncMode Busy
RatioNumerator CommandAborted
RatioDenominator Error
Axis >

CommandAborted
Type: BOOL
Value range: FALSE, TRUE
Initial value: FALSE

Inputs/outputs

Function of the block
Enables the electronic gear.

Notes

- This function is not available.
- **Synchronisation:** before taking up the electronic gear operating mode, there is no synchronisation between guidance signals and motor.

With a compensation movement (*SyncMode* = TRUE) the motor movement is limited only by maximum current (device parameter "Settings.I_max", see [manual](#)) and the maximum rotational speed of the drive. As soon as gear processing is enabled, the control deviation that is caused by the expiring pulses must not be greater than the lag error threshold value (device parameter "Settings.p_maxDif2", see [manual](#)). Otherwise the positioning controller will report a lag error.

Programming languages

The programming system supports all five programming languages of the IEC 61131-3 standard, and generates machine code for all commonly used processes. This means the programming system combines the advantages of higher-level programming languages such as C and PASCAL with the straightforward handling and functions of a PLC programming system.

Instruction list (IL)

An instruction list is a text-oriented programming language and consists of a sequence of instructions. Each instruction starts in a new line and contains an operator and – depending on the type of operation – one or more operands separated from one another by a comma.

There may be an identifier mark before an instruction, followed by a colon. The identifier mark is used for identifying the instruction, and can be used as a jump target, for example.

Example:

```
LD 17
ST lint (* Remark *)
GE 5
JMPC next
LD idword
EQ instruct.sdword
STNtest
next:
```

Structured text (ST)

Structured text is a text-oriented programming language based on the PASCAL high-level language. As in PASCAL, for example, ST also includes conditional programme branches (IF ... THEN ... ELSE) and loops (WHILE ... DO).

Example:

```
IF value < 7 THEN
WHILE value < 8 DO
    value := value + 1;
END_WHILE;
END_IF;
```

Sequential function chart (SFC)

Sequential function chart is a graphically oriented programming language that makes it possible to describe the time sequence of various actions within a programme. For this purpose, step elements are used which can have certain actions assigned to them and the sequence of which is controlled using transition elements.

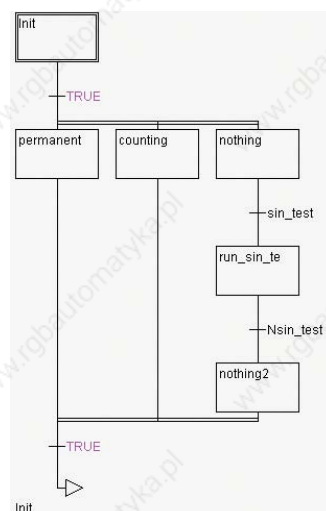

Example of SFC programming language

Ladder diagram (LD)

Ladder diagram is a graphically oriented programming language based on the circuit diagram of an electrical circuit.

Ladder diagram is suitable for constructing logical sequential circuits and creating networks. Therefore, ladder diagram is extremely well suited for controlling calls of other blocks.

Ladder diagram consists of a sequence of networks that are limited on the left and right by vertical current conductors. In between the current conductors, there is a circuit diagram comprising contacts, coils and connection lines.

Each network is made up of a sequence of contacts on the left, which pass on the status "ON" or "OFF" from left to right. There is a Boolean variable for each contact. The status of the variables is passed on to the right.

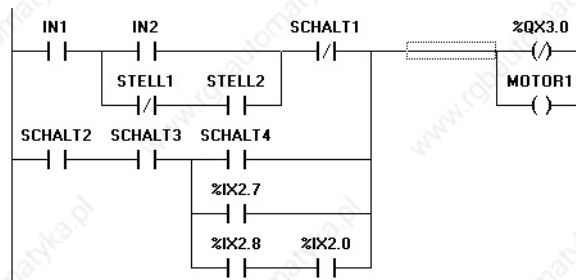

Example of LAD programming language

Function block diagram (FBD)

Function block diagram is a graphically oriented programming language. Function block diagram works with a list of networks, with each network having one structure: This structure can represent the following:

- Logical or arithmetical expression
- Function call
- Jump
- Return instruction

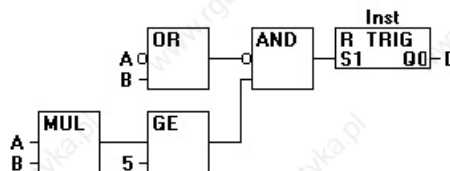

Example of FBD programming languages

Continuous function chart (CFC)

Continuous function chart is based on function block diagram, but works with freely positionable elements instead of with networks. This enables return links, for example.



Example of CFC programming language

Components

Complete offline simulation

All user programmes can be tested offline before being loaded onto the controller.

Online functions

The most important online functions are:

- Breakpoints for tracking programming bugs.
- Sequence check for checking the programme lines as they are run through
- Log book for chronological recording of user actions and internal procedures during an online session
- Trace recording for true-to-cycle recording and display of variable sequences

Monitoring of variables

In online mode, the current values of all variables visible on the screen are read out of the controller and displayed.

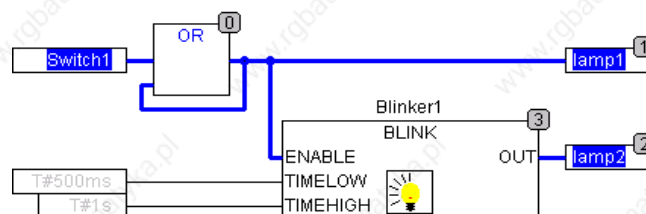

Writing and forcing variables in the controller

One or more variables are permanently set to user-defined values. In this case, setting takes place at the start and finish of a programme cycle in the run-time system (forcing) or once at the beginning of a programme cycle (writing).

```

a = GELB
lebt = 340 <:= 123>
SG
├── r1 = 34.10005
│   ├── sinus = 529.0374
│   └── cosinus = -848.5985
├── Sinus = -848.5985
├── Cosinus = 529.0374
├── r1 = 0
├── by1 = 84
├── by2 = 168
├── by3 = 252
├── bResult = FALSE
└── XY = TRUE
  
```

Writing and forcing variables

Debugging

Programme bugs can be located quickly by setting breakpoints and subsequently running through the programme line-by-line. In single-cycle mode, it is possible to track the sequence of changes within a complete cycle. The "sequence check" function enables programme sections that have been run and, depending on the editor used, also additional information such as temporary values or the accumulator content to be displayed in the instruction list.

```

0001 run_string:='Start';
0002 IF NOT run THEN
0003     RETURN;
0004 END_IF;
0005 run_string:='Stop';
0006
0007 rot := rot + offset;
0008
0009 IF (yVal < 0) THEN
0010     yVal := yVal + offset;
0011     bottom := yVal + offset;
0012 ELSE
0013     IF (xVal < 470) THEN
0014         xVal := xVal+offset;
    
```

```

run_string = 'Stop'
run = TRUE

run_string = 'Stop'

rot = 252

yVal = 0
yVal = 0
bottom = 2

xVal = 0
xVal = 0
    
```

Debugging in CoDeSys

Online change

Online change makes it possible to make changes to the programme whilst it is running on the controller. In this case, it is also possible to make changes to several blocks as well as variables and data types.

Power Flow

In Power Flow, the command lines and/or networks that have been run within the last controller cycle are marked in colour. This reduces the time needed to find out whether a particular code has been run at all. In addition, temporary values within the network or element are displayed in the FBD and CFC editors. The same applies to the accumulator content of blocks in the IL editor.

Trace recording

In trace recording, the sequence of variable values is logged during a particular period. The values are written into a ring memory (trace buffer). When this ring memory is full, the values are overwritten again beginning with the start of the memory. It is possible to record a maximum of 20 variables, each with up to 500 values, at the same time.

Trace recording can be used for testing the application, recording data during commissioning or for triggering events.

The digital memory oscilloscope integrated in the programming system provides a means of presenting data optically.

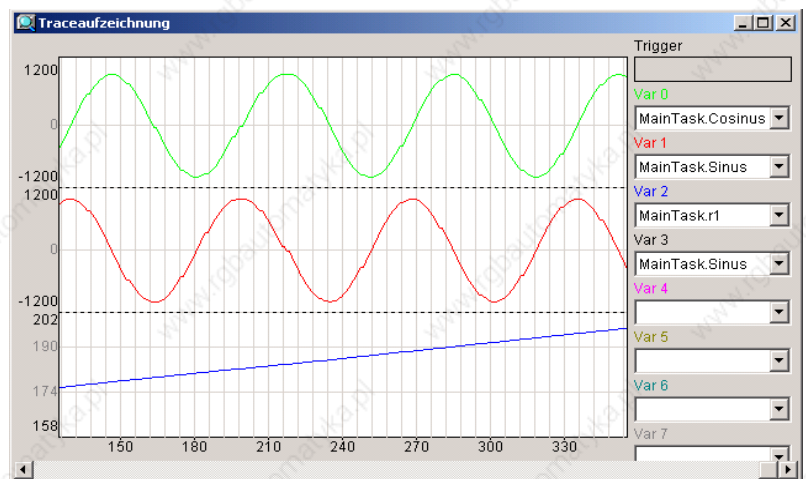

Trace recording

OPC server

The OPC server (OLE for Process Control, OLE: Object Linking and Embedding) is contained in the programming system as standard. It complies with OPC specification 2.0 and runs under MS Windows NT, 2000 and XP.

OPC is a standardised interface for accessing process data. The interface is based on the Microsoft COM/DCOM standard and has been expanded to meet the requirements of data access in automation. In automation, the interface is predominantly used for reading and writing values from the controller.

OPC clients include visualisation systems, programmes for production data acquisition, etc.

OPC servers are provided for PLC systems and fieldbus cards, for example.

The OPC server is not a passive sub-programme library, but a runnable programme

that is started when a connection is established between the client and controller. Therefore, the OPC server can inform the OPC client whenever the value or status of a variable changes.

The properties of DCOM means that it is possible to access an OPC server running on a different computer. In addition, several clients can access the data source at the same time.

Another advantage of using the COM standard is the ability to use different programming languages (C++, Visual, Basic, Delphi, Java).

OPC server 2.0 is capable of communicating with all controllers that can be programmed with CoDeSys.

Library manager

The library manager displays all libraries that are connected to the current project.

The blocks, data types and global variables of the libraries can be used as self-defined blocks, data types and global variables.

Hierarchical graphic PLC configuration

The structure of the blocks is hierarchical, similar to Windows Explorer.

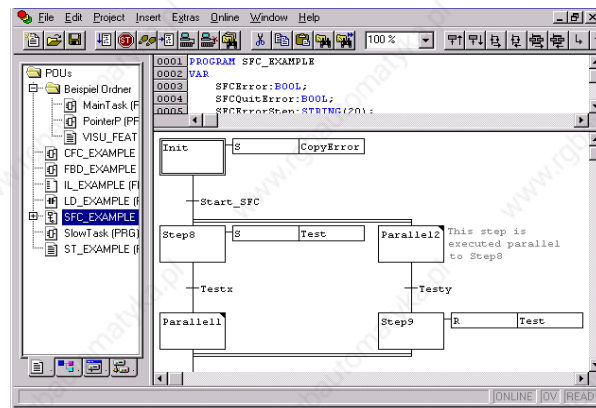

Visualisation

By visualising project variables, geometrical elements can be drawn in offline mode and then their shape, colour or text output can be changed in online mode depending on certain variable values. A visualisation system can also be used as an exclusive user interface for a project with a HMI (Human Machine Interface) or, depending on the target system, also as a web or target visualisation system via the internet or on the target system.

Simulation

In the case of simulation, the generated controller programme is not processed on the controller, but on the computer on which CoDeSys is running. All online functions are available. This means it is possible to check the logical correctness of the programme without having the controller hardware available

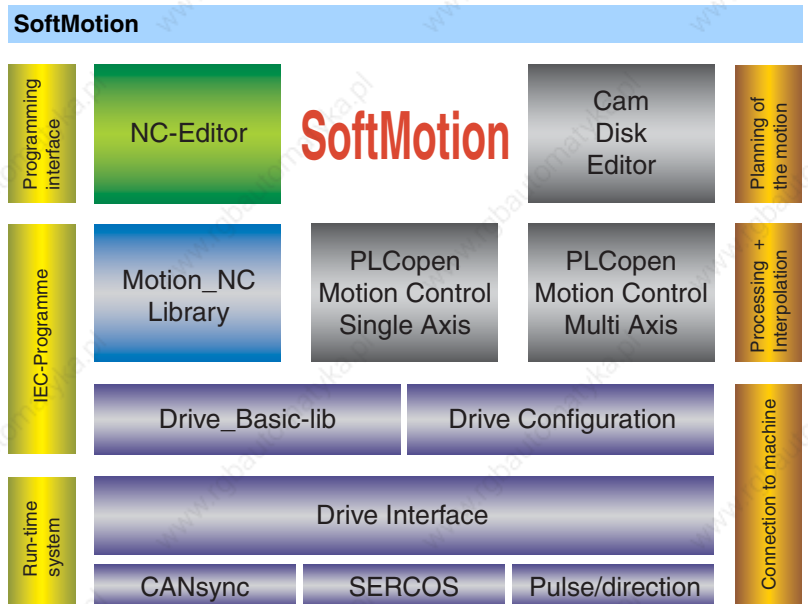

SoftMotion is a part of the programming system and makes it possible to programme highly synchronous movements in controllers with a pulse/direction interface, e.g. TLM2, or in controllers with synchronous fieldbus interfaces such as CANSync or SERCOS.

The possible applications range from single-axis travel movements through to NC track interpolations.

In contrast to other solutions that perform motion tasks with uniform (monolithic) hardware-dependent control systems, SoftMotion provides the motion functions in the form of a modular system. Solutions with any degree of complexity can be created from this.

The axes are made available in an abstract form as a data structure. Drivers from Berger Lahr provide the specific connection to the drive interface.

A configuration tool is available for configuring the drives. The configuration tool integrates the drive interfaces and assigns one or more drive groups to each drive interface.

Various models of the Motion Controller are offered as a modular system based on this concept:

- PLCopen motion blocks
- Electronic cam profile
- Electronic gear
- Various single-axis processes
- 2½-D NC controller

Advantages

Motion programming independent of the drive

Motion programming is largely independent of the drive used. The drives can be replaced by others with a similar power without modifying the software – simply by swapping over the corresponding basic libraries. The motion programme does not need to be changed.

Portability

All motion libraries, with the exception of the ones close to the system, are written in the structured text programming language, which means they can easily be transferred to all platforms supported by the programming system. SoftMotion can currently be used under MS Windows XP and CE, Linux and on embedded platforms with FPU (Floating Point Unit).

Integration in the programming system

SoftMotion is integrated in the programming system. This means the user can benefit from the familiar use of programming in Berger Lahr Motion Controllers. The control programme, motion programming and the associated HMI (Human Machine Interface) can be created with a development environment.

Modular structure

The modular structure means the motion programme can be changed over very easily. For example, it is possible to insert a block for edge rounding or tool radius correction in between the decoder and interpolator.

CNC programming independent of kinematics

The entire CNC programme can be created independently of the kinematics used. The only block that has to be swapped over is the one that handles the transformation, in order to change from a portal robot to a SCARA robot (Selective Compliance Assembly Robot Arm), for example.

No fixed limited

The number of axes or the update rate are only limited by the available computing power, the fieldbus used and the available memory.

Solutions

SoftMotion offers solutions for the following problems:

- Processing machines with NC section
- Special machines with a high PLC proportion
- "Automatic machines" (NC machines without NC programming on the controller)
- Connection to PPS systems
- Production of variants
- Status-dependent drive assignment
- Non-standard transformations
- Non-standard user interfaces

Components

SoftMotion offers the following components:

- A block library with all function blocks for controlling motion as defined by the PLCopen user organisation. This block library is particularly suitable for Master-Slave- axis control.
- An NC block library offering everything from the interpolator to track pre-processing in order to build up a Motion Controller.

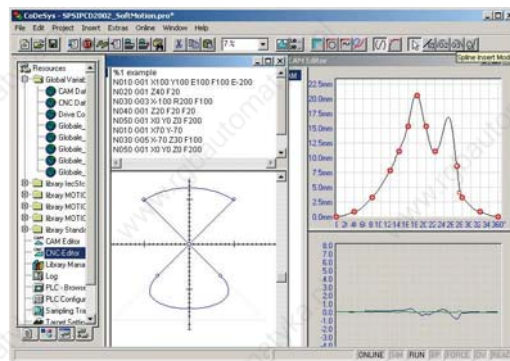

- Drivers from Berger Lahr for the pulse/direction, CANsync and SERCOS drive interfaces (Control with Sercos Master on request)
- Visualisation elements for designing tailor-made interfaces for the application
- Graphic editors with DXF import for planning and entering movements
- Cam profile editor (CAM)

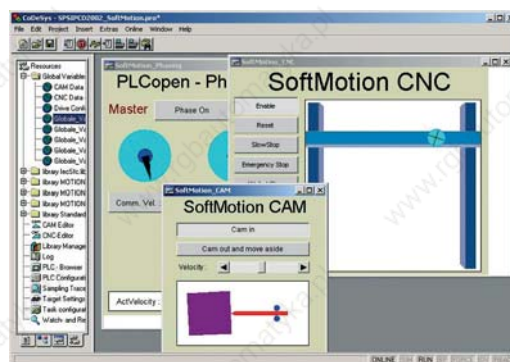

- Visualisation templates for all library functions in order to generate operating and test screens rapidly

Block libraries

There are special block libraries for most Berger Lahr drives in order to assist the work of the application programmer.

All blocks are based on the standards or recommendations of the PLCopen organization.

PLCopen block library

PLCopen is an organization active in the industrial control technology field. PLCopen defines standard blocks for improving the efficiency of application development and for reducing the costs of software maintenance.

PLCopen has as its objective to define international standards that are independent of manufacturers and products, and to promote its widespread use in the area of industrial controller programming.

PLCopen was founded in 1992 and has its headquarters in the Netherlands.

Advantages of Berger Lahr function blocks based on PLCopen:

- The PLCopen Organization supports IEC 61131-3, irrespective of the programming tool.
- PLCopen is a worldwide organization with more than 100 sites in Europe, the USA and Japan.
- All its members are active in process automation.
- It provides non-proprietary function blocks.
- Berger Lahr reduces the programming work required with PLCopen function blocks. This applies in particular to complex motion functions.
- PLCopen blocks are available for each Berger Lahr drive in the Berger Lahr programming system.
- High performance of the function blocks, because it is never the case that all lines are run in one cycle.
- By "encapsulating" internal status transitions and dealing with bugs in the function blocks, Berger Lahr reduces the probability of errors during application programming.

Additional Berger Lahr block library

The Berger Lahr block library contains additional function blocks for controlling Berger Lahr drives. These are not (yet) described in the PLCopen standards.

SoftMotion block library

The SoftMotion block library contains function blocks for programming highly synchronous motion sequences for controllers with pulse/direction, CANsync or SERCOS drive interfaces.

CNC function blocks

CNC function blocks are used for programming CNC-specific functions

Combinations of drives and Motion Controllers

Motion Controllers	Drives						
	ATV31; ATV71	Lexium 05; SD3 28	SD3 26	IcIA IF•	IcIA IDS	TLC4; TLC5; TLC6	TLD
TLC61	CANopen	CANopen	–	CANopen	–	CANopen	–
TLC63	CANopen	CANopen	–	CANopen	–	CANopen	–
SMC	CANopen	CANopen	–	CANopen	–	CANopen	–
TLCC	CANopen	CANopen	–	CANopen	–	CANopen	–
TLM2	CANopen	CANopen, Pulse/direction	Pulse/direction	CANopen	Pulse/direction	CANopen	Pulse/direction

The following table contains a list of block libraries and the function blocks for drives from Berger Lahr and Schneider Electric. Please contact us for information about the block libraries for other Berger Lahr drives.

The function of the individual function blocks is explained briefly at the end.

Overview of function blocks

Single-axis function blocks

For drives with interface Drive type ...	CANopen				TLC4; TLC5; TLC6	Pulse/direction Lexium 05; SD3 2•; IcIA IDS; TLD
	ATV31; ATV71	Lexium 05; SD3 28	IcIA IF•			
PLCopen blocks						
MC_Power	Yes	Yes	Yes	Yes	Yes	Yes
MC_ReadStatus	Yes	Yes	Yes	Yes	Yes	Yes
MC_ReadAxisError	Yes	Yes	Yes	Yes	Yes	Yes
MC_Reset	Yes	Yes	Yes	Yes	Yes	Yes
MC_TouchProbe	No	Yes	Yes	Yes	Yes	Yes
MC_AbortTrigger	No	Yes	Yes	Yes	Yes	Yes
MC_ReadParameter	Yes	Yes	Yes	Yes	Yes	Yes
MC_ReadBoolParameter	No	No	No	No	No	Yes
MC_WriteParameter	Yes	Yes	Yes	Yes	Yes	Yes
MC_WriteBoolParameter	No	No	No	No	No	Yes
MC_ReadActualPosition	No	Yes	Yes	Yes	Yes	Yes
MC_ReadDigitalInput	Yes	Yes	Yes	Yes	Yes	No
MC_ReadDigitalOutput	Yes	Yes	Yes	Yes	Yes	No
MC_WriteDigitalOutput	Yes	Yes	Yes	Yes	Yes	No
MC_SetPosition	No	Yes	Yes	Yes	Yes	Yes
MC_SetOverride	No	No	No	No	No	No
MC_ReadActualVelocity	Yes	Yes	Yes	Yes	Yes	Yes
MC_ReadActualTorque	No	No	No	No	No	Yes
MC_TorqueControl	No	No	No	No	No	Yes
MC_MoveAbsolute	No	Yes	Yes	Yes	Yes	Yes
MC_MoveRelative	No	Yes	No	No	No	Yes
MC_MoveAdditive	No	Yes	Yes	Yes	Yes	Yes
MC_MoveSuperimposed	No	No	No	No	No	Yes
MC_MoveVelocity	Yes	Yes	Yes	Yes	Yes	Yes
MC_Home	No	Yes	Yes	Yes	Yes	Yes
MC_Stop	Yes	Yes	Yes	Yes	Yes	Yes
MC_PositionProfile	No	No	No	No	No	Yes
MC_VelocityProfile	No	No	No	No	No	Yes
MC_AccelerationProfile	No	No	No	No	No	Yes
MC_Jog	No	Yes	Yes	Yes	Yes	Yes
Berger Lahr blocks						
Read parameter						
BL_GetVersion	No	Yes	Yes	Yes	Yes	No
BL_ReadRefPosition	No	Yes	Yes	Yes	Yes	No
BL_ReadRefVelocity	No	Yes	Yes	Yes	Yes	No
BL_ReadRefPositionInc	No	Yes	No	No	No	No
BL_ReadActualMasterPosition	No	Yes	Yes	Yes	Yes	No

Single-axis function blocks

For drives with interface	CANopen				Pulse/direction
Drive type ...	ATV31; ATV71	Lexium 05; SD3 28	IcIA IF•	TLC4; TLC5; TLC6	Lexium 05; SD3 2•; IcIA IDS; TLD
BL_ReadActualMasterVelocity	No	Yes	Yes	Yes	No
BL_ReadActualPositionInc	No	Yes	No	No	No
BL_ReadAnalogInputs	No	Yes	No	Yes	No
BL_ReadActualOffsetPosition	No	No	No	Yes	No
BL_ReadActualOffsetVelocity	No	No	No	Yes	No
Write parameter					
BL_SetDriveRamp	No	Yes	Yes	Yes	No
BL_ResetParameters	No	Yes	Yes	No	No
BL_StoreParameters	No	Yes	Yes	No	No
BL_ConfigureIO	No	No	Yes	No	No
BL_ControlIO	No	No	Yes	No	No
BL_SetLimitSwitch	No	Yes	No	No	No
Motion					
BL_CurrentControl	No	Yes	No	Yes	No
BL_VelocityControl	No	Yes	No	Yes	No
BL_GearOffset	No	No	No	Yes	No
List processing					
BL_ListWriteData	No	No	No	Yes	No
BL_ListAssignType	No	No	No	Yes	No
BL_ListControl	No	No	No	Yes	No
BL_ListReadStatus	No	No	No	Yes	No
Data set processing					
BL_DataSetControl	No	No	No	Yes	No
BL_DataSetPTP	No	No	No	Yes	No
BL_DataSetVelocity	No	No	No	Yes	No
BL_DataSetRamp	No	No	No	Yes	No
BL_DataSetType	No	No	No	Yes	No
BL_DataSetChange	No	No	No	Yes	No
Blocks for ATV31 and ATV71					
BL_DownloadDriveParameter_ATV31	Yes	No	No	No	No
BL_DownloadDriveParameter_ATV71	Yes	No	No	No	No
BL_GetVersion_ATV	Yes	No	No	No	No
BL_ReadAnalogInput_ATV	Yes	No	No	No	No
BL_ResetParameters_ATV	Yes	No	No	No	No
BL_SetDriveRamp_ATV	Yes	No	No	No	No
BL_SetFrequencyRange_ATV	Yes	No	No	No	No
BL_UploadDriveParameter_ATV31	Yes	No	No	No	No
BL_UploadDriveParameter_ATV71	Yes	No	No	No	No
BL_VelocityControlAnalogInput_ATV	Yes	No	No	No	No
BL_VelocityControlSelectAI_ATV	Yes	No	No	No	No

Multi-axis function blocks					
For drives with interface	CANopen				Pulse/direction
Drive type ...	ATV31; ATV71	Lexium 05; SD3 28	IcIA IF•	TLC4; TLC5; TLC6	Lexium 05; SD3 2•; IcIA IDS; TLD
PLCopen blocks					
MC_CamTableSelect	No	No	No	No	Yes
MC_CamIn	No	No	No	No	Yes
MC_CamOut	No	No	No	No	Yes
MC_GearIn	No	Yes	No	Yes	Yes
MC_GearOut	No	Yes	No	Yes	Yes
MC_Phasing	No	No	No	No	Yes
MC_DigitalCamSwitch	No	No	No	No	No
SoftMotion blocks					
SMC_ErrorString	No	No	No	No	Yes
SMC_Error	No	No	No	No	Yes
SMC_GetCamSlaveSetPosition	No	No	No	No	Yes
SMC_CAMEditor	No	No	No	No	Yes
SMC_CAMRegister	No	No	No	No	Yes
SMC_GetTappetValue	No	No	No	No	Yes
SMC_ReadSetPosition	No	No	No	No	Yes
SMC_SetTorque	No	No	No	No	Yes
SMC_CAMVisu	No	No	No	No	Yes
SMC_ReadCAM	No	No	No	No	Yes
SMC_AxisDiagnosticLog	No	No	No	No	Yes
SMC_ReadNCQueue	No	No	No	No	Yes
SMC_ReadNCFile	No	No	No	No	Yes
SMC_VARLIST_Struktur	No	No	No	No	Yes
CNC function blocks					
For drives with interface	CANopen				Pulse/direction
Drive type ...	ATV31; ATV71	Lexium 05; SD3 28	IcIA IF•	TLC4; TLC5; TLC6	Lexium 05; SD3 2•; IcIA IDS; TLD
SoftMotion blocks					
SMC_NCDecoder	No	No	No	No	Yes
SMC_ToolCorr	No	No	No	No	Yes
SMC_AvoidLoop	No	No	No	No	Yes
SMC_SmoothPath	No	No	No	No	Yes
SMC_RoundPath	No	No	No	No	Yes
SMC_CheckVelocities	No	No	No	No	Yes
SMC_LimitCircularVelocities	No	No	No	No	Yes
SMC_Interpolator	No	No	No	No	Yes
SMC_ShowCNCREF	No	No	No	No	Yes
SMC_ShowQueue	No	No	No	No	Yes

In addition, a block library is available that makes it easier for the programmer to perform the transformation (including spatial transformations) and checking of the axes (position, position/speed, speed).

The block library contains, on the one hand, blocks that control the drives with nominal values, simultaneously monitored the nominal values and can detect jumps.

On the other hand, there are blocks available for mathematical forwards and backwards transformations for certain common kinematics. Instances of the forwards transformation blocks can be linked with visualisation templates that are also included, permitting instant and straightforward representation.

The following systems are supported:

- Portal systems
- Portal systems with tool offset
- H-portal system with stationary drives
- 2-link SCARA systems
- 3-link SCARA systems
- Parallel kinematics

Description of the function blocks

Single-axis function blocks

PLCopen blocks

MC_Power	Switches the controller on or off.
MC_ReadStatus	Reads out the motion type of the axis.
MC_ReadAxisError	Reads out an error message.
MC_Reset	Gets the axis out of error status and acknowledges all error messages.
MC_TouchProbe	An axis position is saved on the selected trigger input edge. This is a highly accurate measurement with a time resolution of 50 μ s. This function block is suitable for recording a fiducial position, for example. Depending on the application, it is possible to calculate a position correctly from this but can then be input back into the system using the MC_Phasing function block.
MC_AbortTrigger	The trigger input function MC_TouchProbe is cancelled.
MC_ReadParameter	Reads out the specified parameter.
MC_ReadBoolParameter	Reads out the specified parameter of the type BOOL.
MC_WriteParameter	Writes out the specified parameter.
MC_WriteBoolParameter	Writes out the specified parameter of the type BOOL.
MC_ReadActualPosition	Reads out the current axis position.
MC_SetPosition	Sets the current position of the axis to the specified value without thereby triggering a movement.
MC_ReadActualVelocity	Reads the value of the current speed.
MC_ReadActualTorque	Reads the value of the current torque.
MC_TorqueControl	Controls the current torque.
MC_MoveAbsolute	Movement takes place to a target position at a specified speed and acceleration. Motion parameters such as target position, speed and acceleration can be modified in real time. The axis then continues moving with the new parameters without interrupting movement. Changing to another single-axis movement (MC_MoveAdditive, MC_MoveVelocity) is possible at any time.
MC_MoveRelative	A specified distance is covered starting from the current actual position of the axis, with a specified speed and acceleration. Motion parameters such as target position, speed and acceleration can be modified in real time. The axis then continues moving with the new parameters without interrupting movement. Changing to another single-axis movement (MC_MoveAbsolute, MC_MoveAdditive) is possible at any time.
MC_MoveAdditive	The specified distance is added to the original target position of the axis. Movement takes place to the new target position immediately, with a specified speed and acceleration. Motion parameters such as target position, speed and acceleration can be modified in real time. The axis then continues moving with the new parameters without interrupting movement. Changing to another single-axis movement (MC_MoveAbsolute, MC_MoveAdditive) is possible at any time.
MC_MoveSuperimposed	The current movement (also at standstill) has a relative movement superimposed on it. The original movement is not cancelled.
MC_MoveVelocity	A movement is started with the specified speed and acceleration. Movement takes place to the new target position immediately, with a specified speed and acceleration. The axis then continues moving with the new parameters without interrupting movement. Changing to another single-axis movement (MC_MoveAdditive, MC_MoveVelocity) is possible at any time.
MC_Home	The axis is referenced on a specified position.
MC_Stop	Movement is stopped with a specified deceleration ramp.
MC_PositionProfile	Starts processing of a motion profile that is described by time/position value pairs $(T_1, P_1 \dots T_n, P_n)$. For each value pair, it is the case that the axis is moved at the specified time T_i through the specified position P_i and then activates the next point T_{i+1}, P_{i+1} .
MC_VelocityProfile	Starts processing of a motion profile that is described by time/speed value pairs $(T_1, v_1 \dots T_n, v_n)$. For each value pair, it is the case that the axis adopts the specified speed v_i at the specified time T_i and changes to the speed v_{i+1} at the time T_{i+1} .
MC_AccelerationProfile	Starts processing of a motion profile that is described by time/acceleration value pairs $(T_1, a_1 \dots T_n, a_n)$. For each value pair, it is the case that the axis adopts the specified acceleration a_i at the specified time T_i , maintains it and changes to the acceleration a_{i+1} at the time T_{i+1} .

Single-axis function blocks

Berger Lahr blocks

Read parameter

BL_GetVersion	Returns the version of the block library.
BL_ReadRefPosition	Reads the value of the current position of the motion profile generator.
BL_ReadRefVelocity	Reads the value of the current speed of the motion profile generator.
BL_ReadRefPositionInc	Reads the value of the current position of the motion profile generator in increments.
BL_ReadActualMasterPosition	Reads the current position of the external encoder.
BL_ReadActualMasterVelocity	Reads the current speed of the external encoder.
BL_ReadActualPositionInc	Reads the current position of the motor in increments.
BL_ReadAnalogInputs	Reads the current voltages at the analogue inputs.
BL_ReadActualOffsetPosition	Reads the current nominal position of the motion profile generator during offset positioning in electronic gear mode.
BL_ReadActualOffsetVelocity	Reads the current actual speed of the motion profile generator during offset positioning in electronic gear mode.

Write parameter

BL_SetDriveRamp	Writes the steepness of the acceleration and deceleration ramp.
BL_ResetParameters	Resets the parameter to the factory setting.
BL_StoreParameters	Save all parameters in a non-volatile memory (EEPROM).
BL_ConfigureIO	Configures the inputs/outputs and enables them.
BL_ControlIO	Programmes the inputs and outputs configured with the BL_ConfigureIO block as "programmable".
BL_SetLimitSwitch	Activates / deactivates the limit switches. Activates the limit switches as normally closed or normally open contacts.

Motion

BL_CurrentControl	Starts the "current control" operating mode. The motor current is specified by a parameter or, alternatively, by an analogue input.
BL_VelocityControl	Starts the "speed control" or "oscillator mode" operating mode. The motor speed is specified by a parameter (not in TLC6*) or optionally via an analogue input.
BL_GearOffset	Start offset positioning in electronic gear mode.

List processing

List-controlled operation takes place in the background whilst a movement is being performed and can be used together with all operating modes. When the motor moves past an axis position that is stored in the list, the TRIGGER interface signal of the drive is changed or a new speed is activated.

BL_ListWriteData	Writes the list entries.
BL_ListAssignType	Selects list type: Position/signal list or position/speed list.
BL_ListControl	Starts list processing. A movement that ensures the motor reaches the positions stored in the list must be triggered by a motion block.
BL_ListReadStatus	Reads the current status of list processing.

Data set processing

In data set mode, the drive processes programmed travel data sets. It is possible to select between 50 user-programmable travel data sets for a movement which start a movement in point-to-point or speed mode. Each data set contains entries for position, speed, system of dimensions (absolute or relative) and ramp selection.

BL_DataSetControl	Starts a movement in data set mode.
BL_DataSetPTP	Writes a data set for "point-to-point" mode.
BL_DataSetVelocity	Writes a data set for "profile velocity" mode.
BL_DataSetRamp	Defines acceleration and deceleration ramps for data set mode.
BL_DataSetType	Selects whether the data set data for a movement is used in "point-to-point" or "profile velocity" mode.
BL_DataSetChange	Switches to another data set during movement in data set mode, the new data set being performed immediately.

Multi-axis function blocks

PLCopen blocks

MC_CamTableSelect	Drives with Sercos or pulse/direction interface use polynomial cam profiles. The polynomial cam profiles are calculated by SoftMotion on the controller. The MC_CamTableSelect function block is used for transferring these cam profiles to the drive in order to use the cam profile for a connection.
MC_CamIn	A cam profile connection to a master axis is started by a selected cam profile. The position of the cam profile in relation to the master or slave position is set by "offsets". Expansion factors make it possible to adapt the cam profile dimensions at any time. The cam profile can also be changed at any time even when a connection is active. This involves the currently active cam profile being brought to completion and then the changeover to the new cam profile takes place. This procedure ensures synchronicity is maintained between periodic axes (e.g. packaging machines).
MC_CamOut	An active cam profile connection is terminated and the axis continues moving at the current speed.
MC_GearIn	A speed connection to a master axis is started. If the master is already moving, a smooth approach movement is calculated in order to reach the speed of the master axis as quickly as possible – whilst maintaining the specified limit values. The gear ratio can be modified at any time when a connection is active. As at the start of the connection, a smooth transitional movement to the new connection ratio is calculated automatically.
MC_GearOut	An active speed gear is terminated. The axis continues to move at the current speed.
MC_Phasing	A master-side phase shift for the gear and cam profile connection is established with the specified speed and acceleration.



SoftMotion blocks

SMC_ErrorString	The SMC_ErrorString function returns a string representation of the error depending on the entries for ErrorID (SMC_Error) and Language (SMC_LANGUAGE_TYPE (English, German)).
SMC_Error	The SMC_Error enumeration contains all error numbers generated by SoftMotion FBs.
SMC_GetCamSlaveSetPosition	This block calculates the current nominal position of an axis (slave) if it were connected to the movement of another axis (master) with a cam profile. However, neither of the axes is moved or influenced. This block calculates the current nominal position of an axis (slave) if it were connected to the movement of another axis (master) with a cam profile. However, neither of the axes is moved or influenced.
SMC_CAMEditor	These blocks enable an online cam profile editor to be created.
SMC_CAMRegister	This block represents a cam index gear. It operates – like MC_CamIn – on an MC_CAM_REF structure, although it negates the actual cam profile information and only reads out the cam information.
SMC_GetTappetValue	This block evaluates the tappets output of the MC_CamIn and outputs the current status of a cam.
SMC_ReadSetPosition	This block of the SM_PLCOpen.lib reads out the current nominal position of the drive.
SMC_SetTorque	A nominal torque can be generated with this block if the drive is in "torque" control mode.
SMC_CAMVisu	This block enables an online cam profile to be displayed.
SMC_ReadCAM	This block is used for loading a cam profile at run time and providing the MC_CAMTableSelect and MC_CAMIn blocks. The cam profile must have been created with the CAM editor and saved in a *.CAM file.
SMC_AxisDiagnosticLog	This block can be used for writing selected values of an axis into a file cyclically. The file obtained in this way lends itself ideally to diagnostic purposes.





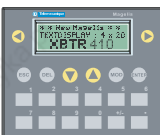

CNC function blocks

SoftMotion blocks

SMC_NCDecoder	The function of the block is to convert a CNC programme created in the CNC editor into a list of SoftMotion-GEOINFO structural objects.
SMC_ToolCorr	The block is used for track preparation: The block generates an offset track based on a specified track, in which each point of each position object is located at a specified distance from its original and its direct neighbour (tool radius correction). It is therefore guaranteed that each of the points in the track generated in this way has a fixed distance from the original track. A typical application involves cutting a programmed contour using a router of a specific thickness. The router bit needs to move along an appropriately offset track – that can be generated with the help of the SMC_ToolCorr block – in order to compensate for the radius of the bit.
SMC_AvoidLoop	The block is used for track preparation: The block uses a specified track to generate a loop-free copy of this track. This means if there is a point in the original track where the track intersects itself, the track is cut out at this point, the loop omitted and movement continues with the rest of the track. This results in a loop-free, uninterrupted track.
SMC_SmoothPath	The block can be used for track preparation. The block rounds off corners in the track and thereby produces a smooth track (corner rounding). The purpose is as follows: if accuracy of movement is less important than speed, this makes it possible to avoid corners at which, of course, it is necessary to decelerate to speed 0.
SMC_RoundPath	The block is very similar to the SMC_SmoothPath block. The block rounds off corners that occur at the intersection of two straight lines, replacing them with arcs.
SMC_CheckVelocities	This block checks the speeds of the individual track segment. It must always be called directly before the interpolator in case the OutQueue was generated in the IEC programme (e.g. by SMC_NCDecoder) instead of by the editor. The main task of this function is to investigate the track for dog-legs and to reduce the speed to 0 there.
SMC_LimitCircularVelocities	This block checks the individual elements of the OutQueue and limits the track speeds of circular elements depending on their radii.
SMC_Interpolator	The SMC_Interpolator block has the task of transferring an existing, uninterrupted track described by GEOINFO objects into discrete track points with consideration for a specified profile velocity and time grid. These position specifications are then normally transformed by the IEC programme (e.g. into the drive axis positions) and sent to the drives via the drive interface.
SMC_ShowCNCREF	This function block (SM_CNCDiagnostic.lib) can display the first 10 lines of an NC programme in text form (DIN 66025). The NC programme must be in form of an SMC_CNC_REF data structure (defined in SM_DriveBasic.lib). An array of string is created as the output (cnostr) containing the text lines. The VISU_SMC_ShowCNCRef visualization template can display these outputs.
SMC_ShowQueue	This function block (SM_CNCDiagnostic.lib) provides the first 10 SMC_GeoInfo objects of an OutQueue in the form of an ARRAY OF POINTER TO SMC_GeoInfo. Some important elements of this can be displayed by the VISU_SMC_ShowQueue visualization template. These include: Object number, line number, object type, start position (X/Y/Z), end position (X/Y/Z), nominal speed and final speed.
SMC_ReadNCQueue	This block reads an OutQueue file from the file system of the controller and provides an OutQueue structure that is typically processed by the interpolator. The OutQueue file must have been generated by the CNC editor.
SMC_ReadNCFile	This block reads an NC-ASCII file from the file system of the controller in order to provide it to the SMC_NCDecoder block. This enables an NC programme to be read in and converted during run time.
SMC_VARLIST_Struktur	IEC1131-3 does not provide a way of obtaining the value of the associated variable from the symbolic variable name that exists as a string, for example. However, this possibility is necessary in order to use the variable functions that are provided to the user with the "programme variable" translation variant when reading in the CNC programme via a file. The SMS_VARLIST structure is therefore used as a solution.

Accessories				
Terminals for TLCC and TLM2				
Alphanumerical terminals				
Terminal	XBT N200	XBT N400	XBT N401	XBT N410
				
Display	Alphanumeric		Matrix display	
• Type	LCD with back lighting		LCD with back lighting, 122 x 32 pixels	
• Colour	Green		Green / orange / red	
• Capacitance	2 x 20 characters		4 x 20 ... 1 x 5 characters (large)	
• Text size	5.55 x 3.2 mm		4.34 x 2.96 ... 17.36 x 11.8 mm	
• Active display area	74 x 12 mm		72 x 20 mm	
Keyboard	8 keys, 4 of which can have new labels			
LED signalling	No LED			6 LEDs, 4 of which are for the 4 central keys
Max. number of pages				
• Application pages	128		200	
• Alarm pages	-		256	
Interfaces				
Serial port	RS232 C, RS485			
	RJ45 female connector (RS232 / RS485)		25-pin sub-D socket	RJ45 female connector (RS232 / RS485)
Protocols	Modbus master, Uni-Telway		Modbus master and slave, Uni-Telway, Sysmac-way	
Electrical power supply	Via the Motion Controller connection cable		Pluggable terminal strip, 3 screw terminals (5.08), securing capacity: 1.5 mm ²	Via the Motion Controller connection cable
Printer port	No printer connection		MiniDin	No printer connection
Terminal	XBT R400	XBT R410	XBT R411	
				
Display	Matrix display			
• Type	LCD with back lighting, 122 x 32 pixels			
• Colour	Green		Green / orange / red	
• Capacitance	4 x 20 ... 1 x 5 characters (large)			
• Text size	4.34 x 2.96 ... 17.36 x 11.8 mm			
• Active display area	72 x 20 mm			
Keyboard	20, 12 of which can have new labels			
LED signalling	No LED		16 LEDs, 14 of which are for the central keys	
Max. number of pages				
• Application pages	200			
• Alarm pages	256			
Interfaces				
Serial port	RS232 C, RS485			
	RJ45 socket (RS232 / RS485)		25-pin sub-D socket	
Protocols	Modbus master, Uni-Telway	Modbus master, Uni-Telway, Sysmac-way	Modbus master and slave, Uni-Telway, Sysmac-way	
Electrical power supply	Via the Motion Controller connection cable	Pluggable terminal strip, 3 screw terminals (5.08), securing capacity: 1.5 mm ²		
Printer port	No printer connection		MiniDin	
Approvals				
Degree of protection according to IEC 60529	CE, UL, CSA, class 1 area 2 (UL and CSA)			
Front panel	IP65, Nema 4X (outdoor use)			
Back panel	IP20			
Visualization software	XBT L1001M (under MS Windows 98SE, 2000 and XP Professional), see page 66 for description			

The terminals can be ordered from Schneider Electric and are described in the Telemechanique catalog "ZXXHMI".

Graphical terminals									
Terminal	XBT GT1100	XBT GT1130	XBT GT2110	XBT GT2120	XBT GT2130	XBT GT2220	XBT GT2230		
									
	XBT GT1100		XBT GT2110			XBT GT2220			
Screen diagonals	3.8"		5.7"						
Resolution	QVGA								
Display type	STN amber + red		STN blue mode	STN black and white		STN colour	TFT colour		
Number of colours	8 gray scales		16 graduations			4096	65536		
Backlighting									
• Type	LEDs		CFL			CFL	CFL		
• Service life	50000 h		58000 h			75000 h	50000 h		
Data input	Matrix touchscreen 8 x 6 and 6 function keys		Analogue touchscreen, resolution 1024 x 1024 pixels						
Memory									
• Application	8 MB		16 MB						
• Backup	512 kB		128 kB	512 kB					
• Supplement	-		Compact Flash Card: 128 MB ... 1 GB						
Electrical power supply	24 V _{DC}								
Interfaces									
Serial port	COM1: RJ45 (RS485-232C)		COM1: 9-pin sub-D (RS232C-422) COM2: RJ45 (RS485)						
USB	No								
Ethernet	No	1 port 10 Base T	No	1 port 10/100 Base T	No	1 port 10/100 Base T			
External dimensions	130 x 104 x 41 mm		168 x 135 x 60 mm						
Terminal	XBT GT4230	XBT GT4330	XBT GT4340	XBT GT5230	XBT GT5330	XBT GT5340	XBT GT6330	XBT GT6340	XBT GT7340
									
	XBT GT4330		XBT GT5330			XBT GT6330			
Screen diagonals	7.5-inch			10.4-inch		12.1-inch		15-inch	
Resolution	VGA					SVGA		XGA	
Display type	STN colour	TFT colour		STN colour	TFT colour				
Number of colors	4096	65536		4096	65536				
Backlighting									
• Type	CFL								
• Service life	54000 h			50000 h					
Data input	Analogue touchscreen, resolution 1024 x 1024 pixel								
Memory									
• Application	32 MB								
• Backup	512 kB								
Interfaces									
Serial port	COM1: 9-pin sub-D (RS232C-422) COM2: RJ45 (RS485)								
USB	1 interface type A master			2 interfaces type A master					
Ethernet	1 port 10/100 Base T								
Inputs/outputs	3 digital outputs, 1 digital input, 1 audio output								
External dimensions	215 x 170 x 60 mm			313 x 219 x 56 mm	271 x 213 x 57 mm		313 x 239 x 56 mm		395 x 239 x 60 mm
Approvals	CE, cULus, CSA, UL class 1 area 2 T4A or T5								
Degree of protection according to IEC 60529									
Front panel	IP65, Nema 4X (outdoor use, indoor use only with holders for screw mounting)								
Back panel	IP20								
Visualization software	Vijeo Designer (under MS Windows 98SE, 2000 and XP Professional), see page 67 for description								

The terminals can be ordered from Schneider Electric and are described in the Telemechanique catalogue "ZXKHMI".

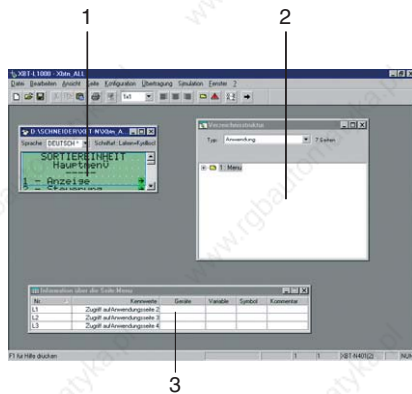

Configuration software XBT L1001M

Description

The configuration software XBT L1001M enables dialog applications to be developed for control panels of the Magelis XBT N and XBT R series. The software XBT L1001M runs on an IBM compatible PC with the MS Windows 98, 2000 and XP operating system. The applications written with the software XBT L1001M are independent of the protocol used; a user application can be used together with various controllers from Berger Lahr.

Structure of the configuration software XBT L1001M:

- (1) Application window (page)
- (2) Navigation window (tree structure of the pages)
- (3) Window with information about the fields of the displayed page

Configuration with XBT L1001M

The configuration software XBT L1001M makes it easy to create various pages, for example:

- Applications pages that can be linked together
- Alarm pages
- Help pages
- Recipe pages

The pages can contain all kinds of variables and graphic objects, that are either defined with the software XBT L1001M or are created and imported with other applications. The following properties can be assigned to the variables and objects, for example:

- Min./max. limit values
- Colour
- Transfer
- Weighting

XBT L1001M can be used for configuring function keys by means of which commands can be issued to the machine or application pages called up. In addition, the PLC symbol databases PL7, Concept or Unity are imported with fully graphic control panels.

Minimum requirements

- IBM-compatible PC with Pentium II processor 350 MHz
- 30 MB free hard disk space
- 64 MB RAM with Windows 98 operating system
- 128 MB RAM with Windows 2000 or XP operating system

Order data		
Designation	Description	Order number
Configuration software XBT L1001M	Scope of delivery: <ul style="list-style-type: none"> • CD-ROM with software for Windows 98, 2000 or XP • Multilingual documentation (de, en, fr, it, es) • Connection cable 	XBTL1001M

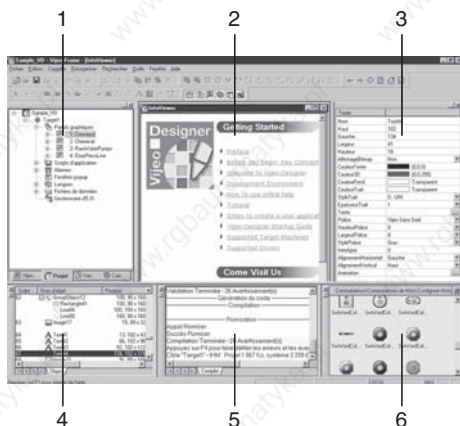

Configuration software Vijeo Designer

Description

The configuration software Vijeo Designer enables dialog applications to be developed for controlling automation systems for control panels in the Magelis XBT GT series.

The software Vijeo Designer runs on an IBM compatible PC with the MS Windows 98, 2000 and XP operating system.

Structure of the configuration software Vijeo Designer:

- (1) Navigator
- (2) Information
- (3) Object properties
- (4) Object list
- (5) Reports
- (6) Library of animated objects

Configuration with Vijeo Designer

The configuration software Vijeo Designer makes it quick and easy to create operator dialog projects. Vijeo Designer is extremely user-friendly because of its six configurable windows:

- Navigator
- Object properties
- Object list
- Library of animated graphic objects
- Information
- Reports

In addition, this software offers extensive tools for managing applications:

- Development of projects consisting of one or more applications
- Cross references of variables
- Documentation of block diagrams
- Simulation mode for testing the application in the design office

Vijeo Designer can be used for configuring function keys by means of which commands can be issued to the machine or application pages called up. In addition, the PLC symbol databases PL7, Concept or Unity Pro are imported with fully graphic control panels.

Minimum requirements

- IBM-compatible PC with Pentium III processor, 800 MHz
- 800 MB free hard disk space
- 256 MB RAM with Windows 2000 or XP Professional operating system

Order data				
Designation	License type	Transmission cable		Order number
		PC-side	Terminal-side Magelis XBT	
Configuration software Vijeo Designer CD-ROM with: • Software • User's manual • Multimedia training (de, en) • Communication protocols	Individual station (1 station)	-	(1)	VJD SND TGS V44M
		USB	XBT G/GT11	VJD SUD TGS V44M
			XBT GT2 ... GT73 Magelis Smart IPC Magelis Compact iPC	VJD SUD TGA V44M
	Group license (3 stations)			VJD GND TGS V44M
	Team license (10 stations)			VJD TND TGS V44M
	Location license (unlimited number of stations at a geographical location)			VJD FND TGS V44M

(1) Individual components: Data transmission cable for transferring the application from the PC to the Magelis XBT control panel

Accessories for terminals			
Designation	Description		Order number
Cable for programming the terminals			
RS232 to Magelis XBT N401, N410, R410, R411	XBTZ915		XBTZ915
RS232 to Magelis XBT N200, N400, N401, N410, R400	XBTZ945 (1/2); XBTZ945 (2/2)		XBTZ945 (1/2) XBTZ945 (2/2)
RS232 to Magelis XBT GT1100	XBTZG915		XBTZG915
Ethernet to Magelis XBT GT1130, 2130, 2230, 2330	Directly connected, a crossed cable must be used. USB cable is supplied with Vijeo Designer.		Is not offered
Ethernet to Magelis XBT GT4230, 4330, 4340			
Ethernet to Magelis XBT GT5230, 5330, 5340, 6330, 6340, 7340			
USB to Magelis XBT GT2110, 2120, 2220	USB cable is supplied with Vijeo Designer.		Included with Vijeo Designer.
USB to Magelis XBT GT1130, 2130, 2330			
USB to Magelis XBT GT4230, 4330, 4340			
USB to Magelis XBT GT5230, 5330, 5340, 6330, 6340, 7340			
Cable for communication between TLCC/TLM2 and terminals			
RS232 to Magelis XBT R400, R410, R411	Cable set for connection		86300901007
RS232 to Magelis XBT N200, N400, N401, N410	Cable set for connection		86300901008
RS232 to Magelis XBT GT1100	Cable set for connection		86300901009
RS232 to Magelis XBT GT2110, 2120, 2220	Standard cable, 9-pin sub-D socket on 9-pin sub-D connector for 1:1 wiring		Is not offered
Ethernet to Magelis XBT GT1130, 2130, 2230, 2330	Standard CAT5 Ethernet cable		
Ethernet to Magelis XBT GT4230, 4330, 4340	Standard CAT5 Ethernet cable		
Ethernet to Magelis XBT GT5230, 5330, 5340, 6330, 6340, 7340	Standard CAT5 Ethernet cable		
Other accessories			
Compact Flash cards	128 MB		XBTGM128
	256 MB		XBTZGM256
	512 MB		MPCYN00CFE00N
	1 GB		MPCYN00CF100N
Spring cage terminals			XBTZ3002
RS232 transmission cable from PC to terminal	For series XBT GT1***		XBTZG925
USB transmission cable from PC to terminal	For series XBT GT2*** ... XBT GT7***		XBTZG935
CAN cable			
Designation	Description		Order number
CAN cable for communication between Motion Controller and Berger Lahr drives			
lclA lxx installation set	Material set for installing a compact drive Contents: 4 pcs. connector housing (supply, signals), crimp contacts, 2 cable entries incl. shield foil strain relief		62501521001
lclA lFx cable	Prepared on the drive side incl. cable entry and strain relief; for supply, CANin and CANout; other cable end: Supply open, CAN 9-pin sub-D		62501462030
CAN cable for TLC•	For connecting the CAN-C module of a TLC• with another CAN station; Equipped with 9-pin sub-D connector and 9-pin sub-D socket.	0.5 m	62501446005
		1.5 m	62501446015
		3 m	62501446030
		5 m	62501446050
		10 m	62501446100

For TLC6				
Designation	Description		Order number	
TL HMI	Twin Line Human Machine Interface for TLC6*; 4 languages (DE, EN, FR, IT)		62501101503	
Operating software TL CT	Twin Line Control Tool for TLC6*; 4 languages (DE, EN, FR, IT)		62501101803	
Ballast Resistor Controller TL BRC	Twin Line Ballast Resistor Controller for TLC63		62501101706	
Ballast resistor	Ballast resistor for TLC63 in connection with the ballast resistor controller TL BRC			
	BWG 250072	100 W / 72 Ω	59060100001	
	BWG 250150	100 W / 150 Ω	59060100002	
	BWG 500072	200 W / 72 Ω	59060100003	
	BWG 500150	200 W / 150 Ω	59060100004	
Holding brake controller TL HBC	For TLC6*		62501101606	
Line filter	For TLC61 without integrated mains filter			
	Mains filter for TLC611	350 W	59051100200	
	Mains filter for TLC612	700 W	62501101900	
Motor cable for 3-phase stepper motors	For connecting a 3-phase stepper motor with TLC61. 3 x 1.5 mm ² + 2 x 1 mm ² , motor-side with 6-pin circular plug, open on device side	3 m	62501317003	
		5 m	62501317005	
		10 m	62501317010	
		15 m	62501317015	
		20 m	62501317020	
		>20 m	On request	
Motor cable for AC synchronous servomotors	For connecting an AC synchronous servomotor with TLC63; Motor-side with 12-pin circular plug, open on device side, shielded Note: The wire diameter of the motor cable must be at least that of the mains power cable. Otherwise, fuses on the supply side may not respond correctly in case of a fault.			
		for TLC632 3 x 1.5 mm ² + 2 x 1 mm ²		
			3 m	62501322003
			5 m	62501322005
			10 m	62501322010
			15 m	62501322015
			20 m	62501322020
			>20 m	On request
			for TLC634 and TLC636 3 x 2.5 mm ² + 2 x 1 mm ²	
			3 m	62501319003
			5 m	62501319005
			10 m	62501319010
			15 m	62501319015
			20 m	62501319020
			>20 m	On request
			for TLC638 3 x 4 mm ² + 2 x 1 mm ²	
			3 m	62501320003
			5 m	62501320005
			10 m	62501320010
			15 m	62501320015
	20 m	62501320020		
	>20 m	On request		
Rotary encoder cable for 3-phase stepper motors	For connecting a 3-phase stepper motor with the RM-C module of the TLC61. 5 x (2 x 0.25 mm ²) + 1 x (2 x 0.5 mm ²), motor-side with 12-pin round encoder plug, device-side with 15-pin sub-D plug with lateral cable output, shielded	3 m	62501440003	
		5 m	62501440005	
		10 m	62501440010	
		15 m	62501440015	
		20 m	62501440020	
		>20 m	On request	

Designation	Description		Order number	
Rotary encoder cable for AC synchronous servomotors	For connecting an AC synchronous servomotor with the RESO-C or the HIFA-C module of the TLC63. 5 x (2 x 0.25 mm ²) + 1 x (2 x 0.5 mm ²), motor-side with 12-pin round encoder plug, device-side with 15-pin sub-D plug with lateral cable output, shielded	3 m	62501439003	
		5 m	62501439005	
		10 m	62501439010	
		15 m	62501439015	
		20 m	62501439020	
		>20 m	On request	
PC interface cable RS232	The TLC6 is connected to the PC for operation and programming via the PC interface cable RS232. Equipped on the device side with 9-pin sub-D connector and 9-pin sub-D socket on the PC side, with lateral cable output	5 m	62501441050	
		10 m	62501441100	
HMI interface cable RS232	The TLC6 is connected to the TL HMI with the HMI interface cable RS232. Equipped on the device side with 9-pin sub-D connector and 9-pin sub-D socket on the PC side, with lateral cable output	1.5 m	62501442015	
		3 m	62501442030	
		5 m	62501442050	
		10 m	62501442100	
Analogue signal cable	For connecting the TLC63 to a higher-level controller.	1.5 m	62501443015	
		3 m	62501443030	
		5 m	62501443050	
		10 m	62501443100	
Ballast cable	Suitable for TLC63			
	For connecting the TLC63 with the ballast resistor controller TL HBC. The wire diameter must be greater than or equal to the mains cable diameter. 2 x 2.5 mm ²	0.5 m	62501444005	
		1.5 m	62501444015	
		3 m	62501444030	
		5 m	62501444050	
		2 x 4 mm ²	0.5 m	62501445005
			1.5 m	62501445015
3 m	62501445030			
CAN cable	For connecting the CAN-C module of a TLC6 with another CAN station; Equipped with 9-pin sub-D connector and 9-pin sub-D socket.	0.5 m	62501446005	
		1.5 m	62501446015	
		3 m	62501446030	
		5 m	62501446050	
		10 m	62501446100	
Terminating connector for CAN cable	The version that is required depends on the output of the CAN module or the CAN master. If the CAN master has a male connector as its output, the CAN terminating connector must be a female connector.	Female connector	62501518002	
		Plug	62501518003	
Pulse-C cable	For connecting a Berger Lahr controller with the PULSE-C module of a TLC6. With 15-pin sub-D connector on the device and controller sides	0.5 m	62501447005	
		1.5 m	62501447015	
		3 m	62501447030	
		5 m	62501447050	
	With 15-pin sub-D female connector on the device side, other cable end open	0.5 m	62501452005	
		1.5 m	62501452015	
		3 m	62501452030	
		5 m	62501452050	
RS422-C cable	For connecting the TLC6* with RS422-C module with an incremental encoder. With 15-pin sub-D connector on the device side, encoder side open	0.5 m	62501448005	
		1.5 m	62501482015	
		3 m	62501482030	
		5 m	62501482050	
Shield connection terminal	For connecting the cable shield of a Twin Line cable with TLC6		62501101400	

Designation	Description		Order number
ESIM-C/RS422-C cable	For connecting the ESIM-C module of a TLC6• with the RS422 interface of another drive for controlling a following axis. With 15-pin sub-D connector on both sides	0.5 m	62501453005
		1.5 m	62501453015
		3 m	62501453030
		5 m	62501454050
ESIM-C cable	For connecting a TLC6• with ESIM-C module with a higher-level position controller or a following axis or a following device. With 15-pin sub-D connector on the device side, other cable end open.	0.5 m	62501449005
		1.5 m	62501449015
		3 m	62501449030
		5 m	62501449050
IBS-C cable	For connecting an INTERBUS-S station with the IBS-C module of a TLC6. Cable with 9-pin sub-D connector and 9-pin sub-D socket.	0.5 m	62501451005
		1.5 m	62501451015
		3 m	62501451030
		5 m	62501451050
Connector set for module slots M1 ... M4	Connector set for self-prepared cables; the connector set contains the necessary sub-D mating plug, hoods and screws for the module slots as well as the RS232 interface.		62501519002
Documentation	Twin Line documentation, CD-ROM	DE / EN / FR / IT	98441113138
	Twin Line Control Tool TLCT	DE	98441113095
		EN	98441113096
		FR	98441113105
		IT	98441113106
	Profibus-DP	DE	98441113126
		EN	98441113125
		FR	98441113127
		IT	98441113128
	CAN, Berger-Lahr profile	DE	98441113122
		EN	98441113121
		FR	98441113123
		IT	98441113124
	CAN, CANopen, DS-402 profile	DE	98441113140
		EN	98441113141
		FR	98441113142
		IT	98441113143
	Interbus-S, IBS	DE	98441113131
		EN	98441113130
		FR	98441113132
		IT	98441113133
	RS-485 interface	DE	98441113135
		EN	98441113134
FR		98441113136	
IT		98441113137	
	Twin Line Human Machine Interface TL HMI	DE / EN / FR / IT	98441113091

Note: Please refer to the Twin Line accessories catalog for a detailed description of the accessories for TLC6.

Appendix

Conversion tables

Rotor mass moment of inertia

	lb-in ²	lb-ft ²	lb-in-s ²	lb-ft-s ² slug-ft ²	kg-cm ²	kg-cm-s ²	g-cm ²	g-cm-s ²	oz-in ²	oz-in-s ²
lb-in ²	–	6.94 x 10 ⁻³	2.59 x 10 ⁻³	2.15 x 10 ⁻⁴	2.926	2.98 x 10 ⁻³	2.92 x 10 ³	2.984	16	4.14 x 10 ⁻²
lb-ft ²	144	–	0.3729	3.10 x 10 ⁻²	421.40	0.4297	4.21 x 10 ⁵	429.71	2304	5.967
lb-in-s ²	386.08	2.681	–	8.33 x 10 ⁻²	1.129 x 10 ³	1.152	1.129 x 10 ⁶	1.152 x 10 ³	6.177 x 10 ³	16
lb-ft-s ² slug-ft ²	4.63 x 10 ³	32.17	12	–	1.35 x 10 ⁴	13.825	1.355 x 10 ⁷	1.38 x 10 ⁴	7.41 x 10 ⁴	192
kg-cm ²	0.3417	2.37 x 10 ⁻³	8.85 x 10 ⁻⁴	7.37 x 10 ⁻⁶	–	1.019 x 10 ⁻³	1000	1.019	5.46	1.41 x 10 ⁻²
kg-cm-s ²	335.1	2.327	0.8679	7.23 x 10 ⁻²	980.66	–	9.8 x 10 ⁵	1000	5.36 x 10 ³	13.887
g-cm ²	3.417 x 10 ⁻⁴	2.37 x 10 ⁻⁶	8.85 x 10 ⁻⁷	7.37 x 10 ⁻⁸	1 x 10 ⁻³	1.01 x 10 ⁻⁶	–	1.01 x 10 ⁻³	5.46 x 10 ⁻³	1.41 x 10 ⁻⁶
g-cm-s ²	0.335	2.32 x 10 ⁻³	8.67 x 10 ⁻⁴	7.23 x 10 ⁻⁵	0.9806	1 x 10 ⁻³	980.6	–	5.36	1.38 x 10 ⁻²
oz-in ²	0.0625	4.3 x 10 ⁻⁴	1.61 x 10 ⁻⁶	1.34 x 10 ⁻⁶	0.182	1.86 x 10 ⁻⁴	182.9	0.186	–	2.59 x 10 ⁻³
oz-in-s ²	24.3	0.1675	6.25 x 10 ⁻²	5.20 x 10 ⁻³	70.615	7.20 x 10 ⁻²	7.06 x 10 ⁴	72	386.08	–

Torque

	lb-in	lb-ft	oz-in	Nm	kg-m	kg-cm	g-cm	dyne-cm
lb-in	–	8.333 x 10 ⁻²	16	0.113	1.152 x 10 ⁻²	1,152	1.152 x 10 ³	1.129 x 10 ⁶
lb-ft	12	–	192	1.355	0.138	13.825	1.382 x 10 ⁴	1.355 x 10 ⁷
oz-in	6.25 x 10 ⁻²	5.208 x 10 ⁻³	–	7.061 x 10 ⁻³	7.200 x 10 ⁻⁴	7.200 x 10 ⁻²	72,007	7.061 x 10 ⁴
Nm	8.850	0.737	141.612	–	0.102	10.197	1.019 x 10 ⁴	1 x 10 ⁷
kg-m	86.796	7.233	1.388 x 10 ³	9.806	–	100	1 x 10 ⁵	9.806 x 10 ⁷
kg-cm	0.8679	7.233 x 10 ⁻²	13.877	9.806 x 10 ⁻²	10 ⁻²	–	1000	9.806 x 10 ⁵
g-cm	8.679 x 10 ⁻⁴	7.233 x 10 ⁻⁵	1.388 x 10 ⁻²	9.806 x 10 ⁻⁵	1 x 10 ⁻⁵	1 x 10 ⁻³	–	980,665
dyne-cm	8.850 x 10 ⁻⁷	7.375 x 10 ⁻⁸	1.416 x 10 ⁻⁵	10 ⁻⁷	1.019 x 10 ⁻⁸	1.0197 x 10 ⁻⁶	1.019 x 10 ⁻⁶	–

Power

	H.P.	W
H.P.	–	745.7
W	1.31 x 10 ⁻³	–

Length

	in	ft	yd	m	cm	mm
in	–	0.0833	0.028	0.0254	2.54	25.4
ft	12	–	0.333	0.3048	30.48	304.8
yd	36	3	–	0.914	91.44	914.4
m	39.37	3.281	1.09	–	100	1000
cm	0.3937	0.03281	1.09 x 10 ⁻²	0.01	–	10
mm	0.03937	0.00328	1.09 x 10 ⁻³	0.001	0.1	–

Engine speed

	rpm	rad/sec	deg./sec
rpm	–	0.105	6.0
rad/sec	9.55	–	57.30
deg./sec	0.167	1.745 x 10 ⁻²	–

Mass

	lb	oz	slug	kg	g
lb	–	16	0.0311	0.453592	453.592
oz	6.35 x 10 ⁻²	–	1.93 x 10 ⁻³	0.028349	28.35
slug	32.17	514.8	–	14.5939	1.459 x 10 ⁴
kg	2.20462	35.274	0.0685218	–	1000
g	2.205 x 10 ⁻³	3.527 x 10 ⁻³	6.852 x 10 ⁻⁵	0.001	–

Temperature

	°F	°C
°F	–	(9 - 32) x 5/9
°C	9/5 + 32	–

Force

	lb	oz	gf	dyne	N
lb	–	16	453.592	4.448 x 10 ⁵	4.4482
oz	0.0625	–	28.35	2.780 x 10 ⁴	0.27801
gf	2.205 x 10 ⁻³	0.03527	–	980.665	N.A.
dyne	2.248 x 10 ⁻⁶	3.59 x 10 ⁻⁶	1.02 x 10 ⁻³	–	0.0001
N	0.22481	3.5967	N.A.	100,000	–

Conversion example:

Conversion from length value 10 inches into meters. In the "Length" table, look for "in" (= inch) in the left column and "m" (= meter) in the header line. The table cell at the intersection of the column and the row indicates the conversion factor: "0.0254". Multiply 10 inches by 0.0254 to obtain the value in meters: 10 in x 0.0254 = 0.254 m.

BERGER LAHR



Berger Lahr offers you the positioning and automation solutions you need, based on our technology and proven series of products. Our comprehensive engineering and consulting service is ready to support and advise you every step of the way.

Berger Lahr is a member company of the Schneider Electric Group. With its Merlin Gerlin, Square D and Telemecanique brands, Schneider Electric is one of the leading providers of electrical and automation-engineering solutions.

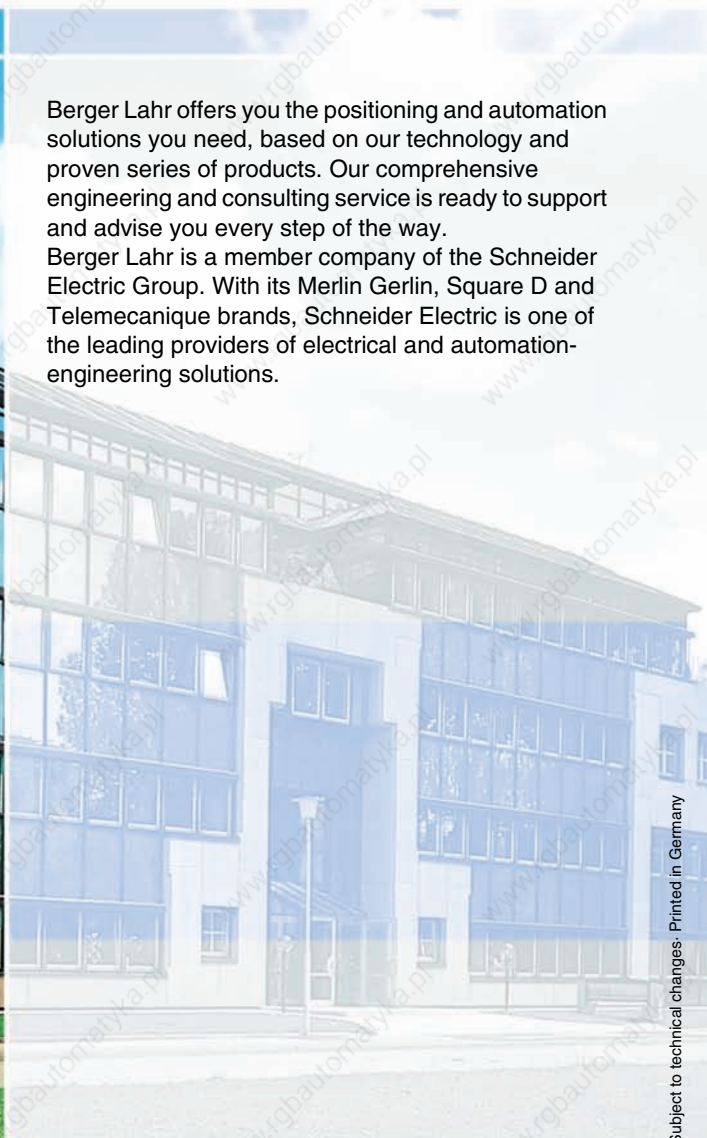

Berger Lahr GmbH & Co. KG
Breslauer Str. 7, D-77933 Lahr
www.berger-lahr.com

