



GE Fanuc Automation

Programmable Control Products

PANELWARE™ Hardware Installation

User's Manual

GFK - 0848A

June 1995

Warnings, Cautions, and Notes as Used in this Publication

Warning

Warning notices are used in this publication to emphasize that hazardous voltages, currents, temperatures, or other conditions that could cause personal injury exist in this equipment or may be associated with its use.

In situations where inattention could cause either personal injury or damage to equipment, a Warning notice is used.

Caution

Caution notices are used where equipment might be damaged if care is not taken.

Note

Notes merely call attention to information that is especially significant to understanding and operating the equipment.

This document is based on information available at the time of its publication. While efforts have been made to be accurate, the information contained herein does not purport to cover all details or variations in hardware or software, nor to provide or every possible contingency in connection with installation, operation, or maintenance. Features may be described herein which are not present in all hardware and software systems. GE Fanuc Automation assumes no obligation of notice to holders of this document with respect to changes subsequently made.

GE Fanuc Automation makes no representation or warranty, expressed, implied, or statutory with respect to, and assumes no responsibility for the accuracy, completeness, sufficiency, or usefulness of the information contained herein. No warranties of merchantability or fitness for purpose shall apply.

The following are trademarks of GE Fanuc Automation North America, Inc.

Alarm Master	Field Control	Modelmaster	Series One
CIMPLICITY	GENet	ProLoop	Series Six
CIMPLICITY	Genius	PROMACRO	Series Three
PowerTRAC	Genius PowerTRAC	Series Five	VuMaster
CIMPLICITY 90-ADS	Helpmate	Series 90	Workmaster
CIMSTAR	Logicmaster		

This manual provides a description of the PANELWARE™ Operator Panels, including Display modules, Keyblock modules, and Panel Controllers. It contains technical data, installation instructions and general information on using PANELWARE Operator Panel applications.

Some of the products mentioned or illustrated in this manual may not be released when this document is published. Please do not rely on any references made to these units. Your local GE Fanuc distributor will inform you of any new product releases.

Revisions to This Manual

- Changes made to this manual describe new features of the PANELWARE system hardware. Additionally, corrections have been made where necessary. The following list describes the major revisions in this manual, as compared to the previous version (GFK-0848).
- Availability of the Genius Panel Controller (C400) — Refer to *PANELWARE Application Manual for Genius Protocol User's Manual* (GFK-1115) for more information.
- To aid in sizing the bulk +24 VDC power supply, a consolidated list of power consumption figures for all PANELWARE components has been added (See appendix C).
- Revision B of the Keyswitch module (IC750KBL920C) has a *normally closed* OFF switch, as compared to Revision A of this module, which has a *normally open* OFF switch.

Content of This Manual

Chapter 1. System Overview outlines the basics of the PANELWARE Operator Panels and provides an overview of possible PANELWARE configurations.

Chapter 2. Assembling System Components describes the modular mechanical structure of PANELWARE panels and illustrates how to assemble a combination to suit the required application. It contains directions for installing the unit in a cabinet or a rack as well as removing and dismantling it, and illustrates the packing contents of each shipped component.

Chapter 3. Display Modules provides a description of the display modules available and explains how to connect them to the panel controller.

Chapter 4. Keyblock Modules describes and explains how to connect the various Keyblock modules to each other and to the panel controller in order to create the required unit.

Chapter 5. Panel Controllers describes the various panel controllers, their connections (interfaces) and all operational elements for which hardware must be configured on the modular panel.

Chapter 6. Accessories illustrates and describes the accessories set and various other optional and replacement PANELWARE components.

Chapter 7. Printers explains the configurations and connections between the serial printer and the C200 panel controller.

Chapter 8. Troubleshooting / Error Diagnosis provides an overview of possible PANELWARE errors, including their causes and possible corrections.

Appendix A. Cabling Information (Connection to the PC) describes the connection and the interface cable required to allow communication between the PANELWARE panel and the PC.

Appendix B. Character Sets lists the two character sets that are available for use on the display modules.

Appendix C. Power Consumption provides a list of power requirements for PANELWARE components to assist in sizing the +24 VDC bulk power supply for the system.

Related Publications

GFK-0849 ***PANELWARE™ Configuration Software Reference Manual***

Describes the PANELWARE Configuration Software and provides the program setups for Panels that are equipped with a programmable controller.

GFK-0850 ***PANELWARE™ MMI Application Manual for GE Fanuc Series 90™ Protocol (SNP)***

Contains specific information on the configuration of PANELWARE Panels that communicate by means of GE Fanuc Series 90 Protocol.

GFK-1112 ***PANELWARE™ Application Manual for Siemens SINEC L1 Driver***

Contains specific information on the configuration of PANELWARE Panels that communicate with Siemens controllers by means of the SINEC L1 protocol.

GFK-1113 ***PANELWARE™ Application Manual for the Modicon MODBUS (RTU/ASCII) Driver***

Contains specific information on the configuration of PANELWARE Panels that communicate with MODICON controllers by means of the MODBUS protocol.

GFK-1115 ***PANELWARE Application Manual for Genius Protocol User's Manual***

This manual contains specific information on the configuration of PANELWARE Panels that communicate with GE Fanuc controllers by means of the Genius protocol.

GFK-1142 *PANELWARE™ Configuration Software Quick Start Guide*

This guide, a companion to the *PANELWARE Configuration Software Reference Manual* (GFK-0849), provides basic information for configuring and using PCS.

GFK-0898 *Series 90-30 Programmable Controller I/O Module Specifications*

Describes the discrete and analog I/O modules for the GE Fanuc Series 90-30 PLC. Contains descriptions of each I/O module and provides specifications and wiring information for each module.

We Welcome Your Comments and Suggestions

At GE Fanuc Automation, we strive to produce quality technical documentation. After you have used this manual, please take a few moments to complete and return the Reader's Comment Card located on the next page.

Libby Allen
Senior Technical Writer

Chapter 1	System Overview.....	1-1
	Operator Interface Panel Basics.....	1-2
	General Information.....	1-2
	PANELWARE Panel Ratings.....	1-3
	Interface Panel Components.....	1-4
	Operation.....	1-4
	PANELWARE Operator Panels.....	1-5
	The Modular Concept.....	1-5
	Display Modules.....	1-6
	Keyblock Modules.....	1-8
	Panel Controllers.....	1-11
	PANELWARE Operator Panel Hook-up.....	1-13
	Programming PANELWARE Operator Panels.....	1-14
	Ordering Information.....	1-15
 Chapter 2	 Assembling System Components.....	 2-1
	General Information.....	2-2
	Tools Required for Assembly.....	2-2
	Component Descriptions.....	2-2
	Assembly Tips.....	2-3
	NEMA 12 and IP54 Ratings.....	2-4
	Power Connection and Grounding Recommendations.....	2-4
	Panel Configurations.....	2-4
	Cleaning the Display and Keys.....	2-4
	Installation Options.....	2-5
	Cutout Dimensions and Installation.....	2-5
	Mounting Bezels.....	2-6
	Package Contents.....	2-9
	Display Module Type 1 (20 Character).....	2-9
	Display Module Type 2 (40 Character).....	2-9
	Standard Keyblock Modules.....	2-10
	Special Keyblock Modules.....	2-10
	Panel Controllers.....	2-11
	Keyblock Label Insertion/Exchange.....	2-12
	Installation Procedure.....	2-15
	Panel Assembly.....	2-15
	Panel Installation.....	2-19
	Panel Removal.....	2-21
	Panel Disassembly.....	2-23
	Controller Battery Installation/Replacement.....	2-26

Chapter 3	Display Modules: Overview.....	3-1
	General Information	3-2
	Backlight (LCD Displays Only)	3-2
	Contrast (LCD Displays Only).....	3-2
	Connection to the Panel Controller	3-3
	Display Modules with LCD Displays	3-4
	Display Module 2 x 20 LCD.....	3-4
	Display Module 4 x 20 LCD.....	3-5
	Display Module 4 x 40 LCD.....	3-6
	Display Module 8 x 40 LCD.....	3-7
	Display Modules with VFD Displays.....	3-8
	Display Module 2 x 20 VFD.....	3-8
	Display Module 2 x 40 VFD.....	3-9
	Accessories	3-10
Chapter 4	Keyblock Modules	4-1
	General Information	4-2
	Dimensions.....	4-2
	Standard and Special Keyblock Modules.....	4-3
	Keyblock Labels	4-3
	Keyblock Cables.....	4-4
	Standard Keyblock Modules.....	4-5
	Connection to Panel Controller or Another Keyblock Module	4-5
	Keyblock Module 16 Keys	4-7
	Keyblock Module Numeric (12+4 Keys)	4-8
	Keyblock Module 8 Keys.....	4-9
	Keyblock Module 4 Keys.....	4-10
	Special Modules.....	4-11
	Blank Module	4-11
	Emergency Stop Switch	4-12
	Key Switch Module	4-13
	Start/Stop	4-15
	Accessories/Replacement Components.....	4-16
Chapter 5	Panel Controllers.....	5-1
	General Information	5-2
	24 VDC Power Requirement.....	5-2
	Connecting Power to Controller.....	5-2
	Setting Number Switches	5-2
	Basic Panel Controller (C200).....	5-3
	Specifications	5-3
	Overview of Connections and Operational Elements	5-4

	Genius Panel Controller (C400).....	5-8
	Specifications	5-8
	Overview of Connections and Operational Elements	5-9
	Operating the Controllers	5-13
	FlashPROM	5-13
	RESET Modes.....	5-13
	Loading and Starting Panel Programs.....	5-14
	Update Mode/Reloading the Operating System	5-15
	Accessories.....	5-15
Chapter 6	Accessories.....	6-1
	Accessories Set (Spare Parts)	6-2
	Lithium Battery.....	6-3
	Label Sheets	6-4
	Mounting Bezels	6-5
	Serial Cables and Adapter	6-5
	Lamps for Special Keyblock Modules	6-5
Chapter 7	Printers.....	7-1
	Printer to Panel Controller.....	7-2
	Printer to C200.....	7-2
	Printer to C400.....	7-2
	Interface Selection	7-2
	Cabling Schematic	7-3
Chapter 8	Troubleshooting/Error Diagnosis.....	8-1
	General Information	8-2
	Visual Check	8-2
	Powering On for the First Time.....	8-2
	Starting an Application	8-2
	Error Messages on Panel Displays with C200 or C400 Controllers	8-3
	Other Errors.....	8-4
Appendix A	Cabling Information	A-1
	Panel Controller to PC Connections.....	A-2
	Cabling Schematic	A-3
Appendix B	Character Sets.....	B-1
	Character Set for VFD and Graphics-Capable LCD Displays	B-2
	Character Set for Character-Oriented LCD Displays.....	B-6
Appendix C	Power Consumption.....	C-1

Chapter 1

System Overview

This chapter provides a basic description of PANELWARE Operator Interface Panels and gives an overview of possible configurations. It includes the following information:

- Operator Interface Panel Basics1-2
 - General Information1-2
 - PANELWARE Panel Ratings1-3
 - Interface Panel Components.....1-4
 - Operation.....1-4
- PANELWARE Operator Panels.....1-5
 - The Modular Concept1-5
 - Display Modules1-6
 - Keyblock Modules1-8
 - Panel Controllers1-11
- PANELWARE Operator Panel Hook-up1-13
- Programming PANELWARE Operator Panels.....1-14
- Ordering Information1-15

Operator Interface Panel Basics

General Information

The visualization of applications and their creation using software has become one of the most important developing factors in automation technology. Operator interface (Man-machine interface — MMI) devices provide the means of entering accurate machine parameters as well as displaying the status of various operations throughout a process application. Applications involving visualization and automation tasks can be completed effectively using a wide range of devices — from full terminals to moderate and low cost smaller Operator Interface Panels.

Table 1 - 1. MMI Device Comparison (Panels vs Terminals)

	Panel	Terminal
Display Type	Primarily line displays LCD, VFD, EL or TFT displays	Usually semi or full-graphic monitors CRT, EL or TFT displays
Size	Depends on the number of lines	Mainly 12-inch or 14-inch CRT screens
Character size	Approx. 4 to 15 mm (.15 to .59 inches)	----
Unit size	Panels are smaller and more compact than terminals.	
Unit depth	Panels generally have a shallower depth than terminals. The mounting depth of terminals with an EL or TFT display averages somewhere between that of Panels and of terminals with CRT displays.	
Weight	Panels are usually lighter.	

The advantages of Operator Panels include:

- Compact structure
- Light weight
- Shallow mounting depth
- Sturdier than terminals

A wide range of Operator Panels is required to visualize and control industrial applications. Cost, size and efficiency are a few of the criteria examined when choosing the right Panels for an application. The largest Panel does not always provide the best solution; modular Panels that can be configured and combined to suit your needs might provide the optimal solution.

PANELWARE Panel Ratings

All PANELWARE Operator Panels are rated for NEMA 12 and IP54 operation once they are properly sealed and mounted in a panel cutout. These ratings are not guaranteed if the included sealant is not used to install the Panel.

Table 1-2 lists the PANELWARE components that have UL and C-UL listings.

Table 1 - 2. PANELWARE Components That Have UL and C-UL Listings

Component	Catalog Number	Revision*
C200 Controller	IC750CTR200	B
C400 Controller	IC750CTR400	-
16 Key, 16 LED Keyblock	IC750KBL160	B
Numeric Keyblock	IC750KBL400	B
4 Key, 4 LED Keyblock	IC750KBL440	B
8 Key, 4 LED Keyblock	IC750KBL840	B
Emergency Stop Block	IC750KBL910	B
Key Switch Block	IC750KBL920	C
Start/Stop Block	IC750KBL930	B
20 x 20 LCD Display	IC750LCD220	B
4 x 20 LCD Display	IC750LCD420	B
4 x 40 LCD Display	IC750LCD440	B
2 x 20 VFD Display	IC750VFD220	B
2 x 40 VFD Display	IC750VFD240	B
8 x 40 CFL Display	IC750CFL840	B

*For each component, the revision level shown and all subsequent revisions have UL and C-UL listings

Interface Panel Components

Operator Panels are comprised of two main external components — **keys** and a **display**. The keys on a Keyblock module are used to make function selections that cause actions to occur and messages to appear on the display. The number of keys on a module and the number of lines and characters that can appear on a display vary from device to device.

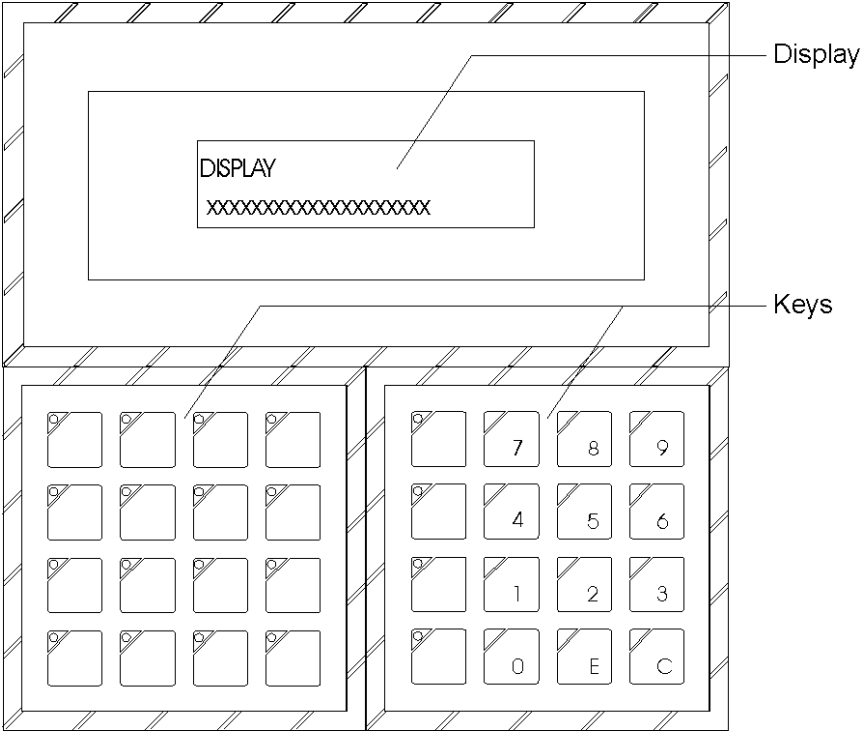

Figure 1 - 1. Interface Panel Components

Operation

Intelligent Panels are completely self-sufficient in their Keyblock and display management. A dedicated processor takes over the task of data display. This processor handles the visualization of PLC data in the form of animated bar graphs, lists, numeric values or messages. The Panel responds when programmed keys are pressed and the resulting data is either displayed on the Panel or sent to the PLC.

The PLC only sends the data; the Panel modifies that data into the desired format and delivers it to the operator over the display. In this way, intelligent Panels save on PLC processing requirements.

PANELWARE Operator Panels

The Modular Concept

PANELWARE Operator Panels are based upon a “modular” structure, which permits combinations of different display sizes, different numbers of keys, and processing power. This modular structure provides an abundance of Panel variations that can be configured to fit the requirements of industrial applications.

Every PANELWARE Panel consists of three basic elements, which are described in detail in the following pages and illustrations:

- one Display module
- one Panel Controller
- Keyblock modules (maximum seven)

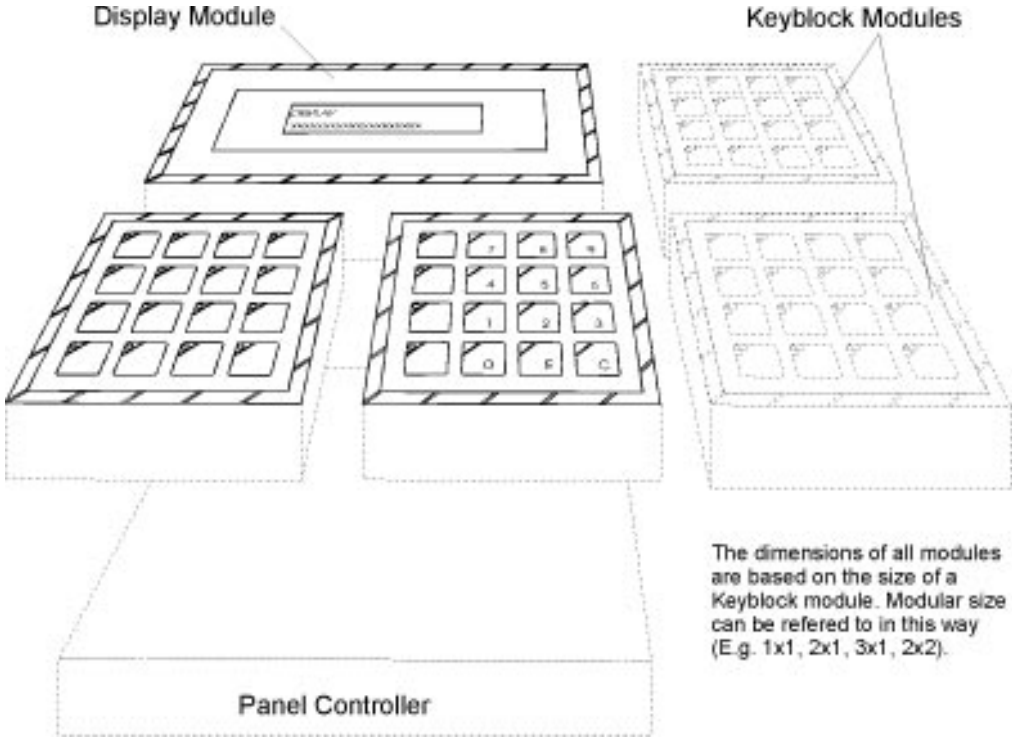

Figure 1 - 2. PANELWARE Panel Elements

Display Modules

Table 1 - 3. Display Module Descriptions (Type 1 = 2 Wide; Type 2 = 3 Wide)







Display Module 2 x 20 LCD (Type 1)	
	<p>Catalog number: IC750LCD220 Size: 2 lines of 20 characters Type: Back-lit LCD display Character height: 5.0 mm Graphics capability: No</p>
Display Module 4 x 20 LCD (Type 1)	
	<p>Catalog number: IC750LCD420 Size: 4 lines of 20 characters Type: Back-lit LCD display Character height: 8.0 mm Graphics capability: No</p>
Display Module 4 x 40 LCD (Type 2)	
	<p>Catalog number: IC750LCD440 Size: 4 lines of 40 characters Type: Back-lit LCD display Character height: 4.3 mm Graphics capability: No</p>
Display Module 8 x 40 LCD Graphic CFL (Type 2)	
	<p>Catalog number: IC750CFL820 Size: 8 lines of 40 characters Type: Back-lit LCD display Character height: 4.0 mm Graphics capability: Yes</p>

Table 1 - 3. - Continued

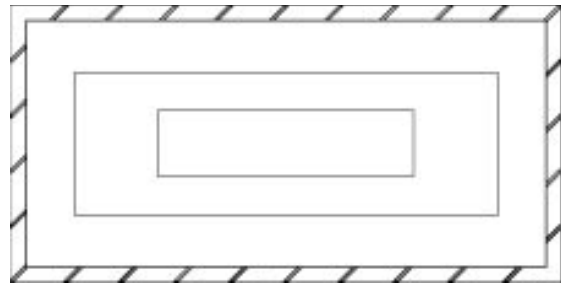
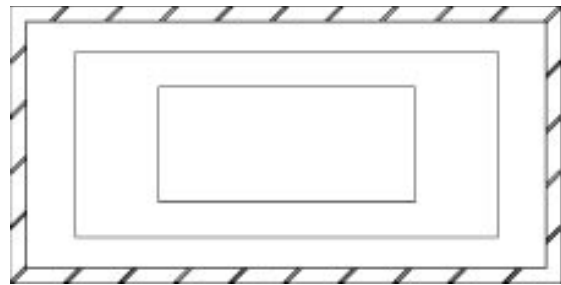
Display Module 2 x 20 VFD (Type 1)	
	<p>Catalog number: IC750VFD220</p> <p>Size: 2 lines of 20 characters</p> <p>Type: VFD display</p> <p>Character height: 5.0 mm</p> <p>Graphics capability: No</p>
Display Module 2 x 40 VFD (Type 2)	
	<p>Catalog number: IC750VFD240</p> <p>Size: 2 lines of 40 characters</p> <p>Type: VFD display</p> <p>Character height: 5.0 mm</p> <p>Graphics capability: No</p>

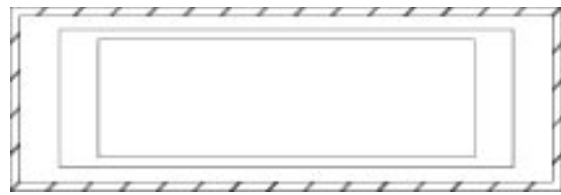
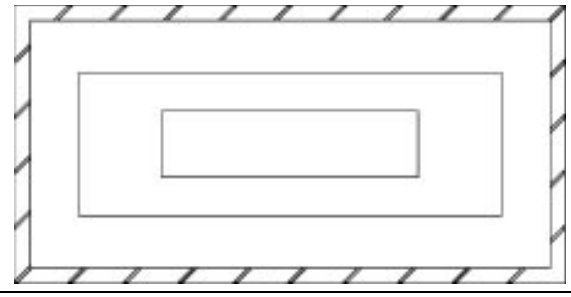
Keyblock Modules

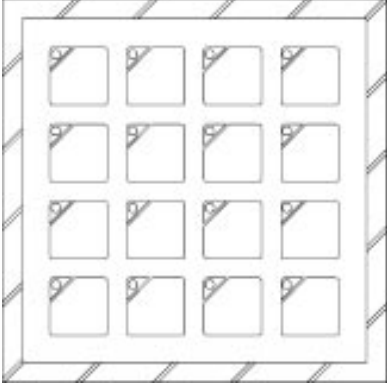
Table 1 - 4. Keyblock Module Descriptions

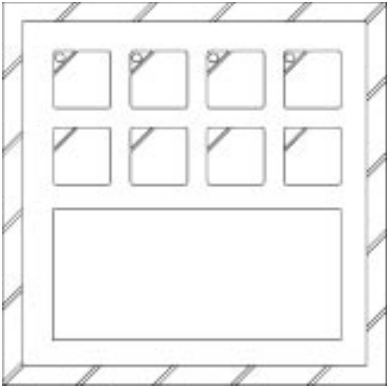
16 Keys	
	<p>Catalog number: IC750KBL160</p> <p>Keys: 16</p> <p>LEDs: 16</p>
Numeric (12 + 4 Keys)	
	<p>Catalog number: IC750KBL400</p> <p>Keys: 16</p> <p>LEDs: 4</p>
8 Keys	
	<p>Catalog number: IC750KBL840</p> <p>Keys: 8</p> <p>LEDs: 4</p> <p>Label fields: 1</p>

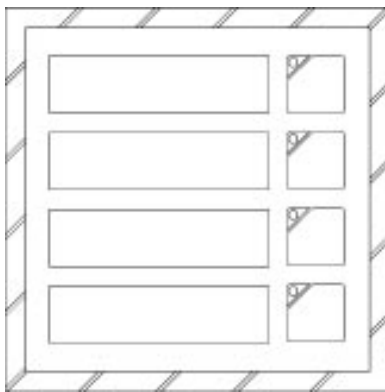
4 Keys	
	<p>Catalog number: IC750KBL440</p> <p>Keys: 4</p> <p>LEDs: 4</p> <p>Label fields: 4</p>

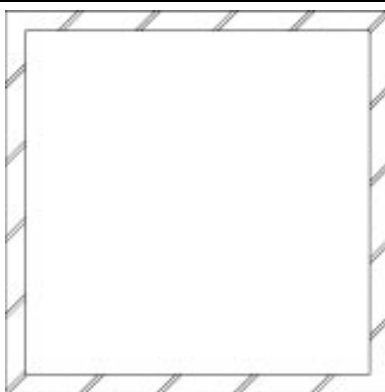
Blank Module	
	<p>Catalog number: IC750KBL000</p> <p>Keys: None</p> <p>LEDs: None</p>

Emergency stop	
	<p>Catalog number: IC750KBL910</p> <p>EMERGENCY</p> <p>STOP</p> <p>2 normally closed high-current contacts</p>

Key Switch	
	<p>Catalog number: IC750KBL920</p> <p>Key switch: 1</p> <p>Key switch high current contacts: 1 normally open and 1 normally closed</p> <p>ON switch: normally open high-current contact</p> <p>OFF switch: normally closed high current contact</p>

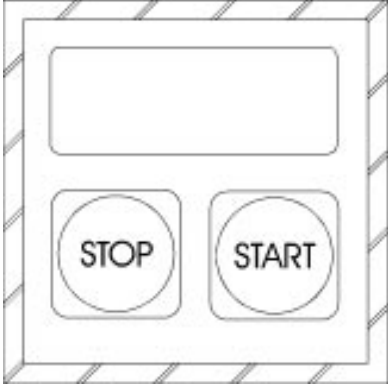
Start/Stop	
	<p>Catalog number: IC750KBL930</p> <p>Keys: 2</p> <p>Label fields: 1</p> <p>1 normally open/1 normally closed high-current contact</p>

The **Emergency Stop**, **Key Switch**, and **Start/Stop** modules are special modules that conform to the same mechanical standards and design as all other PANELWARE modules. They cannot, however, be connected electrically to other Keyblock modules or to the Panel Controller. They must be connected to their respective functions by a qualified electrician. The **Blank Module** falls in a separate class altogether, as it has no electrical connections whatsoever.

Panel Controllers

Table 1 - 5. Basic (C200) Panel Controller Description

Basic Panel Controller (C200)	
	
Catalog number: IC750CTR200	
Interfaces: RS-422/485 RS-232 RS-232	
Programming software: PANELWARE Configuration Software (PCS)	

Table 1 - 6. Genius (C400) Panel Controller Description

C400 Panel Controller	
	
Catalog number: IC750CTR400	
Interfaces: RS-232 GENIUS	
Programming software: PANELWARE Configuration Software (PCS)	

PANELWARE Operator Panel Hook-up

Panel to PLC

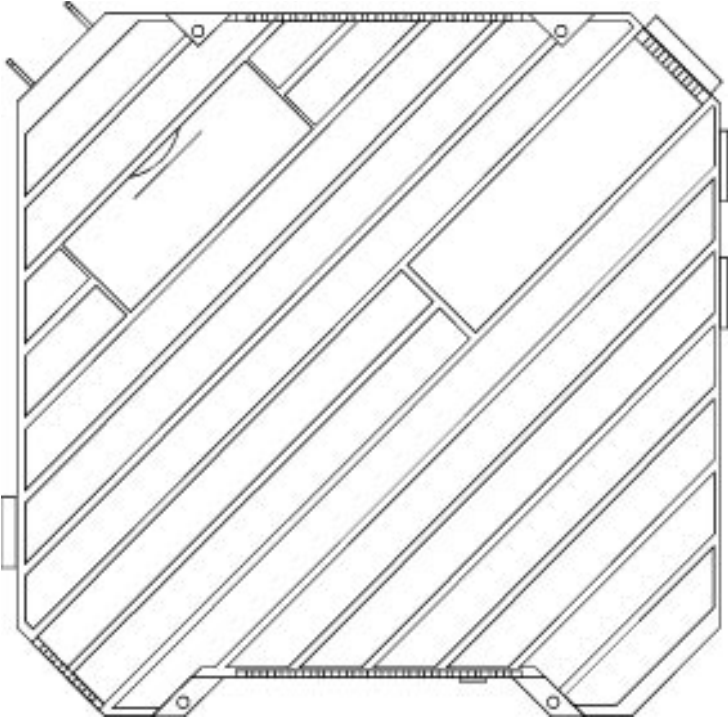
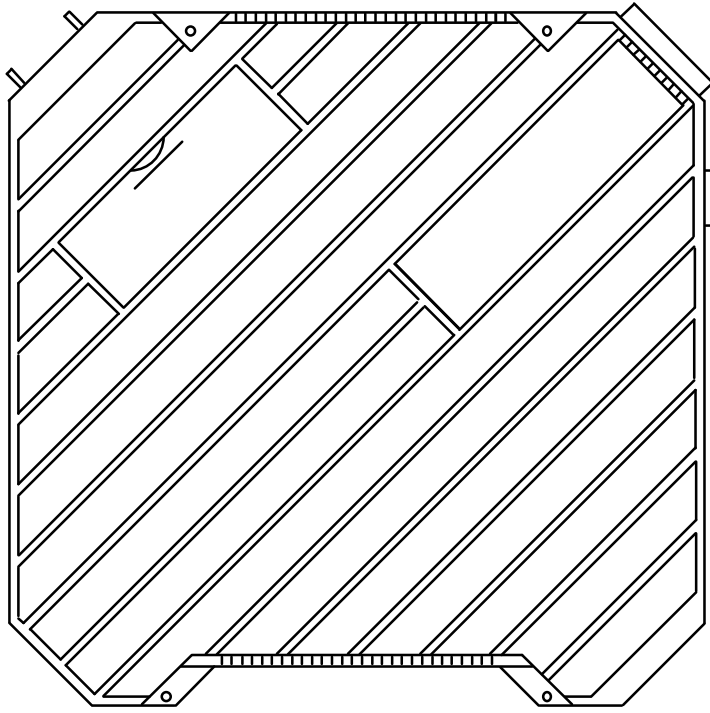
Panels with Controller C200 or C400 can be linked directly to a PLC, as shown below.

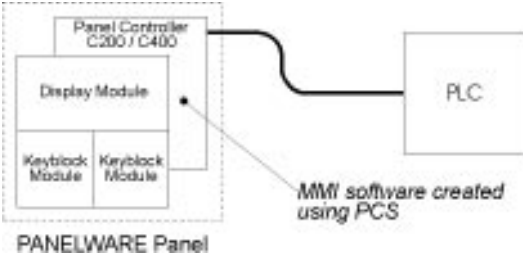

Figure 1 - 3. PANELWARE Panel Connection to PLC

Programming PANELWARE Operator Panels

The complete visualization and management of Keyblock functionality is handled by the Panel Controller. A program is created using PCS running on a PC, then transferred to the Panel. This program takes care of the PLC data exchange (data is written to or read from the PLC) to the display and from the keys.

Note

For information on loading and running PCS, see the PANELWARE Configuration Software Reference Manual (GFK-0849). For information specific to the Genius (C400) Panel Controller, refer to the *PANELWARE™ MMI Application Manual for GE Fanuc Genius™ Protocol User's Manual* (GFK-1115).

Ordering Information

Table 1 - 7. Product Catalog Numbers

Product	Catalog Number
Display Modules	
Display Module 2 x 20 LCD	IC750LCD220
Display Module 4 x 20 LCD	IC750LCD420
Display Module 4 x 40 LCD	IC750LCD440
Display Module 8 x 40 LCD	IC750CFL840
Display Module 2 x 20 VFD	IC750VFD220
Display Module 2 x 40 VFD	IC750VFD240
Keyblock Modules	
Keyblock Module - 16 keys	IC750KBL160
Keyblock Module - Numeric (12 + 4 keys)	IC750KBL400
Keyblock Module - 8 keys	IC750KBL840
Keyblock Module - 4 keys	IC750KBL440
Keyblock Module - Blank module	IC750KBL000
Keyblock Module - Emergency Stop - key	IC750KBL910
Keyblock Module - Key switch	IC750KBL920
Keyblock Module - Start/Stop	IC750KBL930
Panel Controllers	
Basic Panel Controller, C200	IC750CTR200
Genius Panel Controller, C400	IC750CTR400
Accessories	
Accessories set (spare parts kit)	IC750ACC004
Lithium battery (RENATA CR2477N)	IC750ACC002
Label sheets	IC750ACC005
Mounting bezel, 2X3 configuration	IC750ACC230
Mounting bezel, 2X2 configuration	IC750ACC220
RS-232 serial cable (with 25-pin to 9-pin adapter)	IC750CBL002
RS-422 serial cable	IC750CBL001

The components that are delivered with each module are listed in the corresponding chapters in this manual (“Display Modules,” “Keyblock Modules,” “Panel Controllers,” and “Accessories”).

Chapter 2

Assembling System Components

This chapter describes how to assemble PANELWARE system components to suit the required application. Illustrated, easy-to-follow steps are provided, as well as general information on system components and maintenance. (In addition to the general information provided in this chapter, please refer to installation instruction sheets that are packaged with some individual components.)

- General Information 2-2
 - Tools Required for Assembly 2-2
 - Component Descriptions 2-2
 - Assembly Tips 2-3
 - NEMA 12 and IP54 Ratings 2-4
 - Cleaning the Display and Keys 2-4
 - Power Connection and Grounding Recommendations 2-4
 - Panel Configurations 2-4
- Installation Options 2-5
 - Cutout Dimensions and Installation 2-5
 - Mounting Bezels 2-6
- Package Contents 2-9
 - Display Module Type 1 (20 Character) 2-9
 - Display Module Type 2 (40 Character) 2-9
 - Standard Keyblock Modules 2-10
 - Special Keyblock Modules 2-10
 - Panel Controllers 2-11
- Keyblock Label Insertion/Exchange 2-12
- Installation Procedure 2-15
 - Panel Assembly 2-15
 - Panel Installation 2-19
- Panel Removal 2-21
- Panel Disassembly 2-23
- Controller Battery Installation/Replacement 2-26

General Information

Tools Required for Assembly

Each PANELWARE Operator Panel module (Display, Keyblock or Panel Controller) is shipped with all components and accessories necessary for assembly. The following tools (not provided) are required for assembly and maintenance of the Panel:

- 1 Phillips-head screwdriver (#1 size)
- 1 small, flat-head screwdriver

Component Descriptions

Each of the components/accessories required to connect and install PANELWARE modules is described briefly below.

- Purple plastic *mounting pins* that resemble keys are inserted at an angle (with the tab fitting into the corner of the hole) in the corners of modules, then turned to the left or right to lock into place. These are used to mount the spring clips.
- A 1-inch *ribbon cable* (30-pin) connects the Panel Controller to the Display module. Small tabs in the middle of each connector must be aligned (tabs up) for insertion.
- Purple plastic *spring clips* are fastened around the edges of the installed Panel to snug it up to the cutout or mounting bezel.
- Short *Keyblock cables* with telephone-type connectors on each end connect Keyblock modules to each other and to the Panel Controller, input to output. These cables are held in place by cable covers once they are installed. A longer Keyblock cable is provided with each Controller unit.
- *Module connectors* are placed between Keyblock modules when a multi-Keyblock configuration is created to connect the units to one another.
- Purple plastic *cable covers* (approximately 1.5 inches long) are snapped into place over Keyblock cables to keep them in place.
- A *termination resistor* (with one telephone-type connector) is plugged into the output of the last Keyblock module.
- A *lithium battery* allows the Controller to store data such as historical alarm lists. A battery cover on the back of the Controller lifts off to provide access to the housed battery.
- A tube of *sealant* (with application nozzle and squeezing tool) is provided to install the assembled Panel into a cutout or ungasketed mounting bezel (**this sealant must be used to maintain the NEMA 12 and IP54 ratings**).
- Paper *Keyblock label sheets* are written on and inserted into each Keyblock module to indicate programmed key functions. A blank label sheet comes pre-installed in every Keyblock module; extras are provided with each Controller and can be ordered separately.
- Four metal *screws* are provided for attaching the Controller (Phillips #1).

Assembly Tips

The following assembly tips and comments should make Panel assembly and installation easier:

Caution

Failure to observe these assembly tips may result in damaged equipment and/or additional assembly time.

Caution

Handle plastic parts gently; using force may cause plastic to break.

- Insert and remove the ribbon cable carefully. Do not use a screwdriver or other metal object to remove the cable as this could strip insulation off of the wires.
- When applying sealant, observe the following guidelines:
 - Use sealant in a well ventilated area; do not inhale vapors for prolonged periods.
 - Make sure the mounting surface is clean and free of grease.
 - Remove sealant cap and attach the application nozzle, then use the squeezing tool (if necessary) to expel sealant.
 - Applied sealant requires approximately 2 hours at room temperature to cure.
 - Squeeze out a thin line of sealant and try not to create clumps. If too much sealant is applied, it may ooze onto front of unit.
 - If applying sealant around the mounting bezel, take care not to place sealant too close to the spring clips. Place the sealant around each mounting bolt as well.
 - If you are using a gasket around the mounting bezel, do not use sealant on the gasket or the bezel.
 - To remove sealant, rub/lift it off with a spatula, a rag, or paper. Wash off any residue using benzene or a similar solvent.
- Write on and insert Keyblock labels **prior to unit assembly** if functions are programmed.
- The metal Controller screws self-tap into plastic and can only be inserted and removed a limited number of times before the plastic will begin to lose grip.
- Insert mounting pins at an angle, lining up the pin tab with the groove in the insertion point.
- Set the Panel Controller number switch settings (operating mode) before installing the unit into the cutout. If possible, leave enough room to access these settings with a screwdriver after installation.
- Units should not be permanently installed until programming has been completed.
- Make sure all cable connections and any other protrusions are tucked inside the Panel, flush against the unit, before installing in a cutout or mounting bezel.

NEMA 12 and IP54 Ratings

All PANELWARE Operator Panels are rated for NEMA 12 and IP54 operation once they are properly sealed and mounted in a Panel/cutout.

- A NEMA 12 rating indicates that the enclosure provides a degree of protection against dust, falling dirt, and dripping non-corrosive liquids. It is designed to meet drip, dust, and rust-resistance tests.
- An IP54 rating indicates that the enclosure is protected against dust (dust may not interfere with operation) and splashing water.

These ratings are not guaranteed if the included sealant is not used to install the Panel.

Power Connection and Grounding Recommendations

The 24 VDC power connector on the Controller is located on the top left corner of the unit. It is an orange 4-pin connector.

Caution

Do not try to run PANELWARE off a Series 90-30 power supply revision M or earlier. Although some configurations might function under this setup, it is not recommended. Damage to the 90-30 power supply could result.

The suitability of a Series 90-30, revision N or later power supply depends on the +24VDC isolated load requirements of the modules in your PLC. Refer to the *Series 90-30 Programmable Controller I/O Module Specifications (GFK-0898)* to determine additional load requirements of your system.

All components of a PLC and the devices it is controlling must be properly grounded. This is particularly important for the reasons listed below:

- A low-resistance path from all parts of a system to earth ground minimizes exposure to shock in the event of short circuits or equipment malfunction.
- PANELWARE Operator Panels require proper grounding for correct operation.

The importance of grounding can not be over emphasized.

Panel Configurations

When you are laying out the configuration for a Panel, keep in mind that the unit must be rectangular in shape. Any empty spaces must be filled by blank Keyblock modules.

Configurations that include special modules can not be mounted in a 2 X 2 mounting bezel. In addition, because of their depth, some special Keyblocks will only work in a few of the possible Keyblock locations.

Cleaning the Display and Keys

To keep the display and Keyblocks free from dust and smudges, simply wipe them down gently using a damp, soft cloth.

Installation Options

Once a Panel unit is assembled, it can be installed either directly into a precisely cut out opening in a panel, or into a mounting bezel that is then installed in the cutout (certain configurations only). These pre-cut bezels are available as an accessory and provide the benefit of allowing a less precise cutout to suffice for installation.

The following sections outline the two installation options.

Cutout Dimensions and Installation

The cutouts that will house the operator Panels must be precision-cut rectangles with tolerances of -0; +0.5mm per dimension.

Cutout size should be calculated as follows:

$$\text{Dimension (mm)} = 96 * \text{number of blocks} - 4\text{mm} \text{ (-0; +0.5mm tolerance/dimension)}$$

Table 2 - 1. Product and Cutout Dimensions

Matrix Size	Product Dimensions	Cutout Dimensions ¹⁾
1	96 mm/3.78 inch	92 mm/3.63 inch
2	192 mm/7.56 inch	188 mm/7.41 inch
3	288 mm/11.34 inch	284 mm/11.19 inch
4	384 mm/15.12 inch	380 mm/14.97 inch
1)	Tolerances: -0 mm +0.5 mm (0 inch + 0.02 inch)	

The following figure shows an example cutout for a 2 X 3 operator Panel.

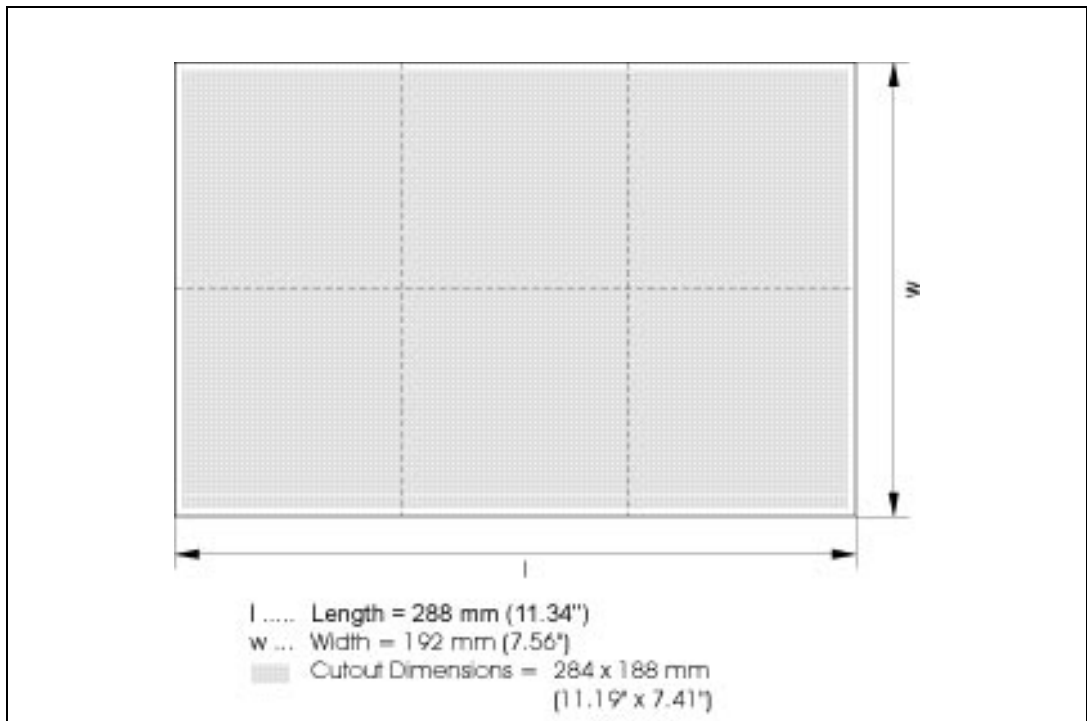

Figure 2 - 1. Cutout Example for a 2 X 3 Panel

Mounting Bezels

A pre-cut, stainless steel mounting bezel can be used for installing two specific configurations of PANELWARE Panels — units that are 2 X 3 (2 high by 3 wide) and units that are 2 X 2 (2 high by 2 wide). Each bezel has mounting bolts welded to it and the remaining installation hardware (captive locking washers and nuts) is provided as well.

The mounting bezel can be installed in a less precise cut, making Panel installation simpler and less costly. The assembled Panel is sealed into the bezel, then the entire unit is installed and sealed into the system cutout.

Note

If you are using a gasket on the bezel, do not apply sealant to either the gasket or the bezel.

The 2 X 3 bezel can be ordered using catalog number IC750ACC230; the 2 X 2 bezel can be ordered using order number IC750ACC220. See chapter 6, "Accessories" for more information. The mounting bezel's dimensions and cutout information are provided in figures 2-2 and 2-3:

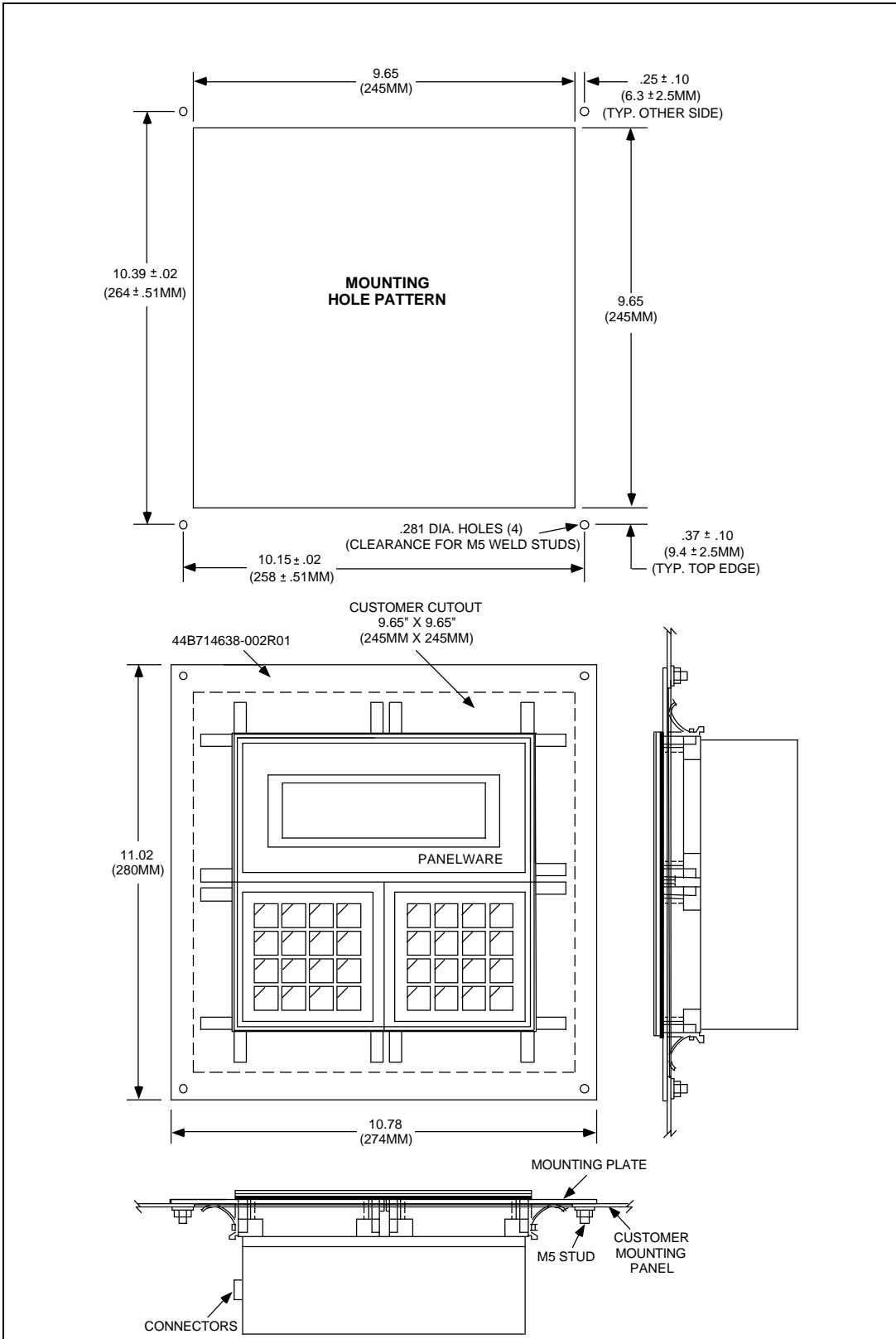

Figure 2 - 2. Mounting Bezel Configuration - 2 X 2 Bezel

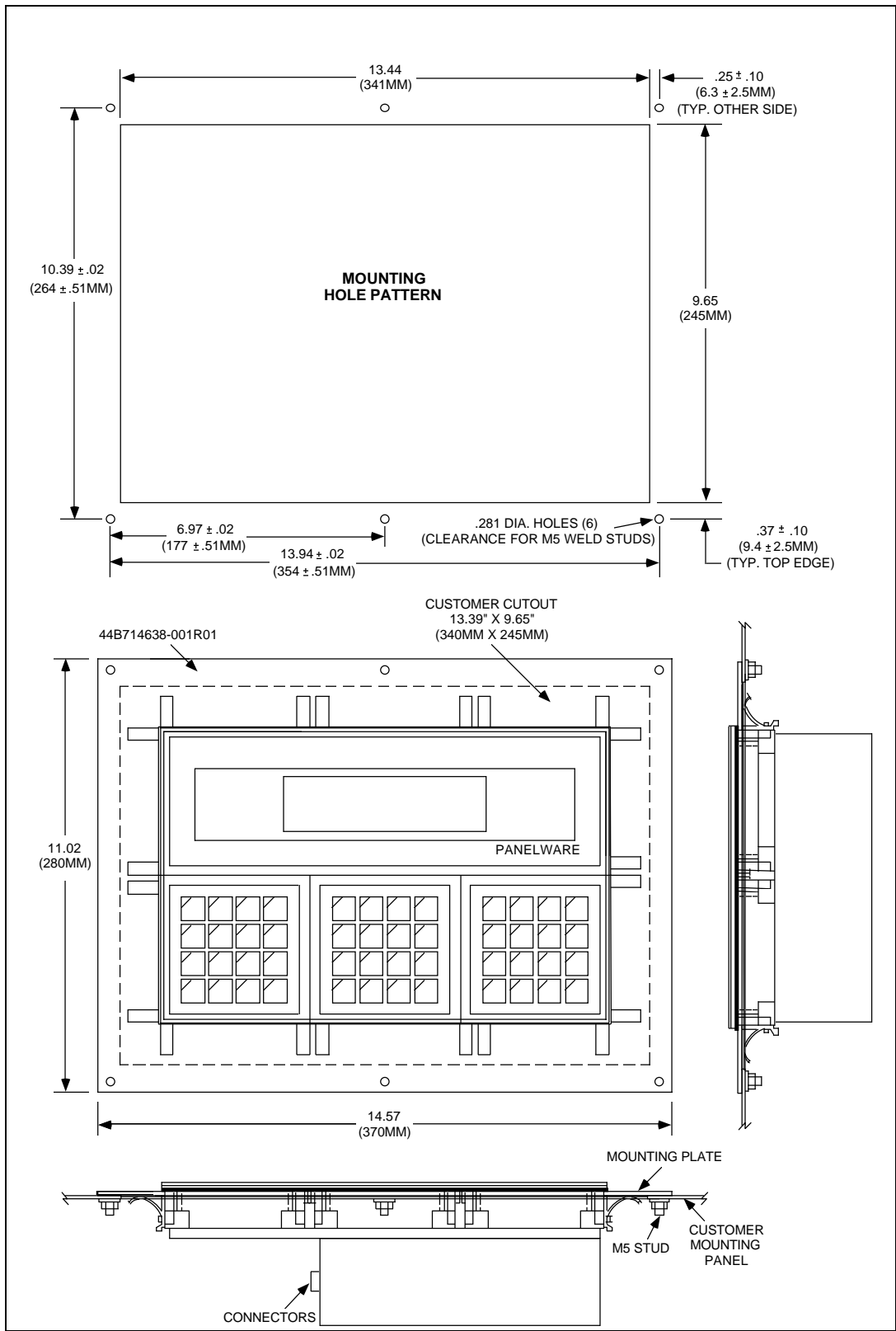
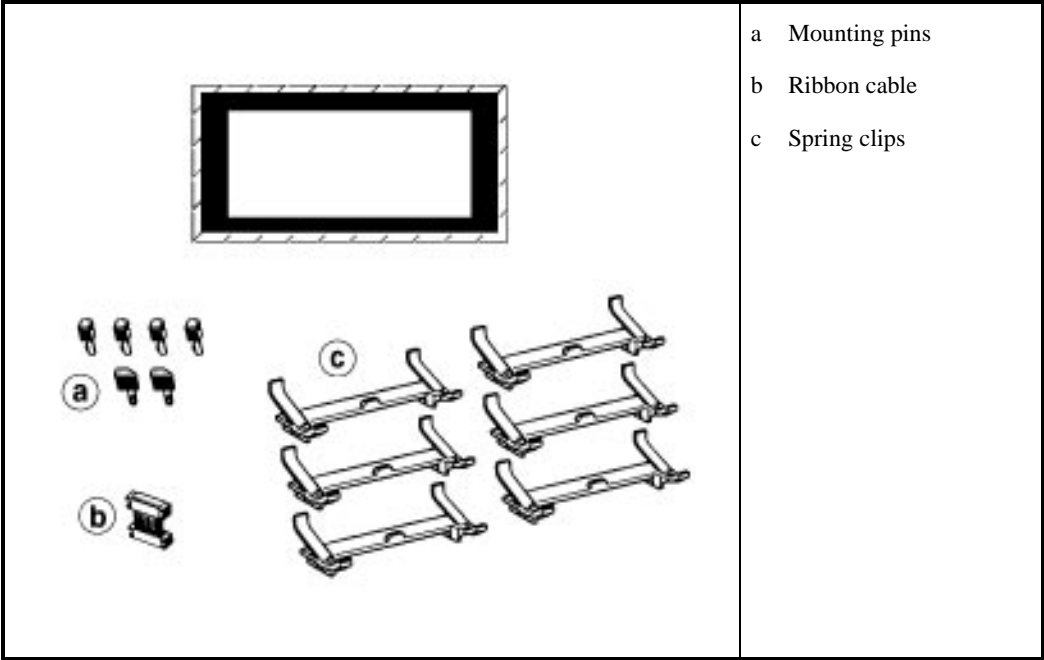

Figure 2 - 3. Mounting Bezel Configuration - 2 X 3 Bezel

Package Contents

Display Module Type 1 (20 Character)



- a Mounting pins
- b Ribbon cable
- c Spring clips

Display Module Type 2 (40 Character)

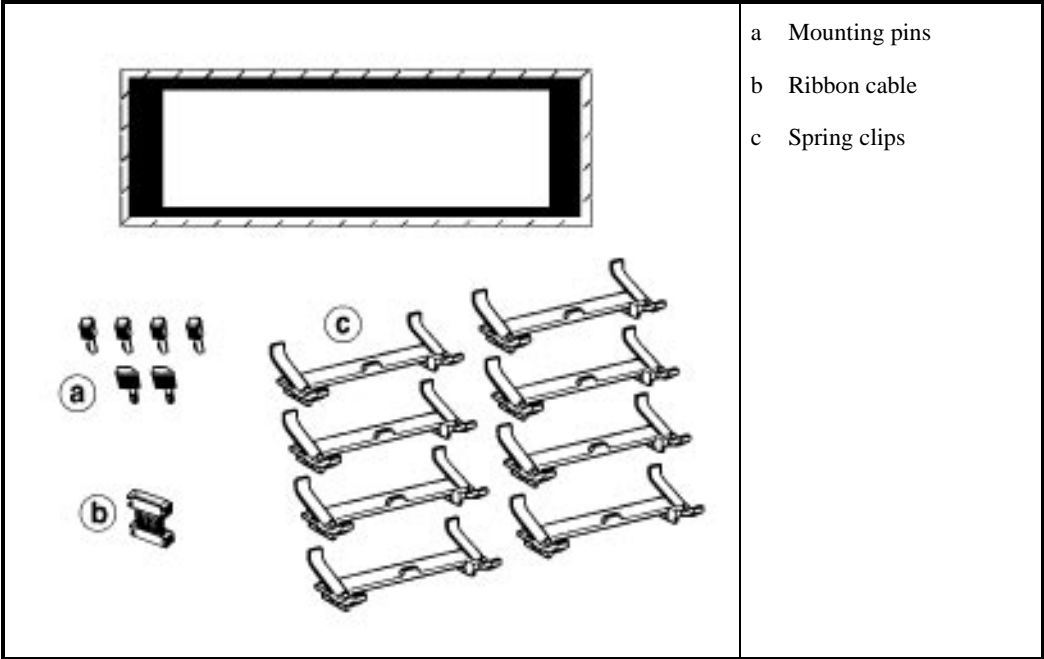

- a Mounting pins
- b Ribbon cable
- c Spring clips

Standard Keyblock Modules

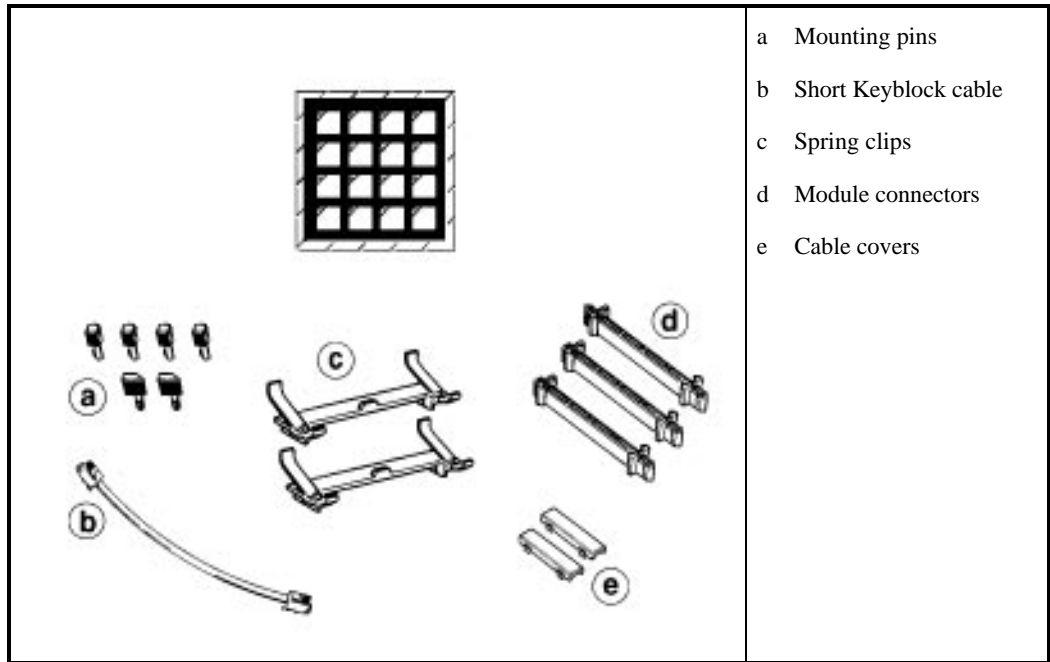

Special Keyblock Modules

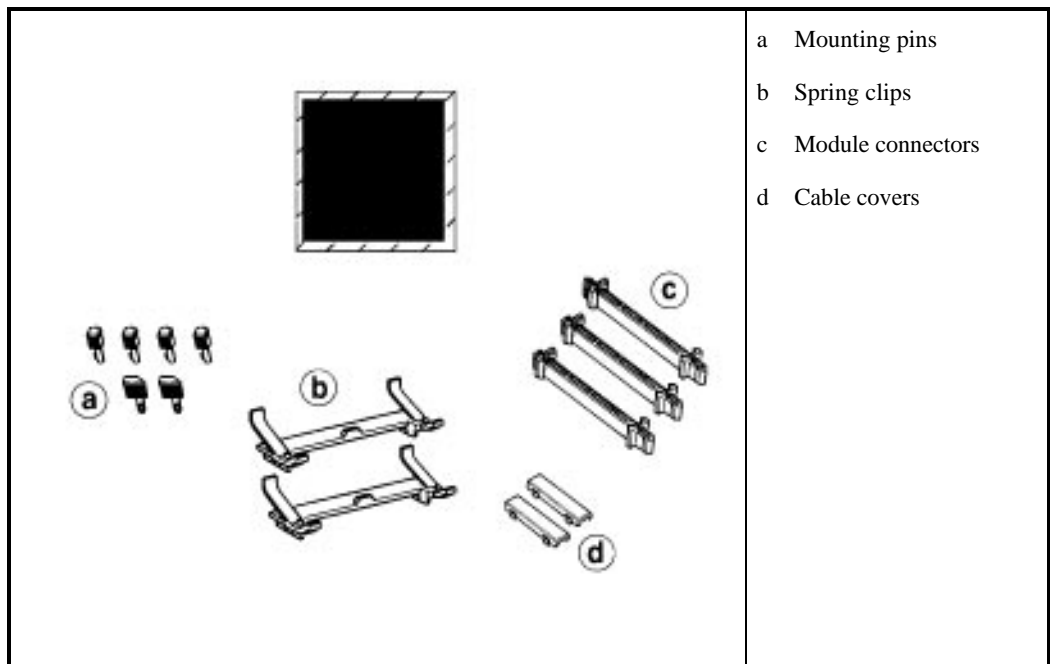

Panel Controllers

Please refer to the instruction sheet that is packaged with your Panel Controller for detailed installation instructions. (The C200 Controller is shown in the figure below.)

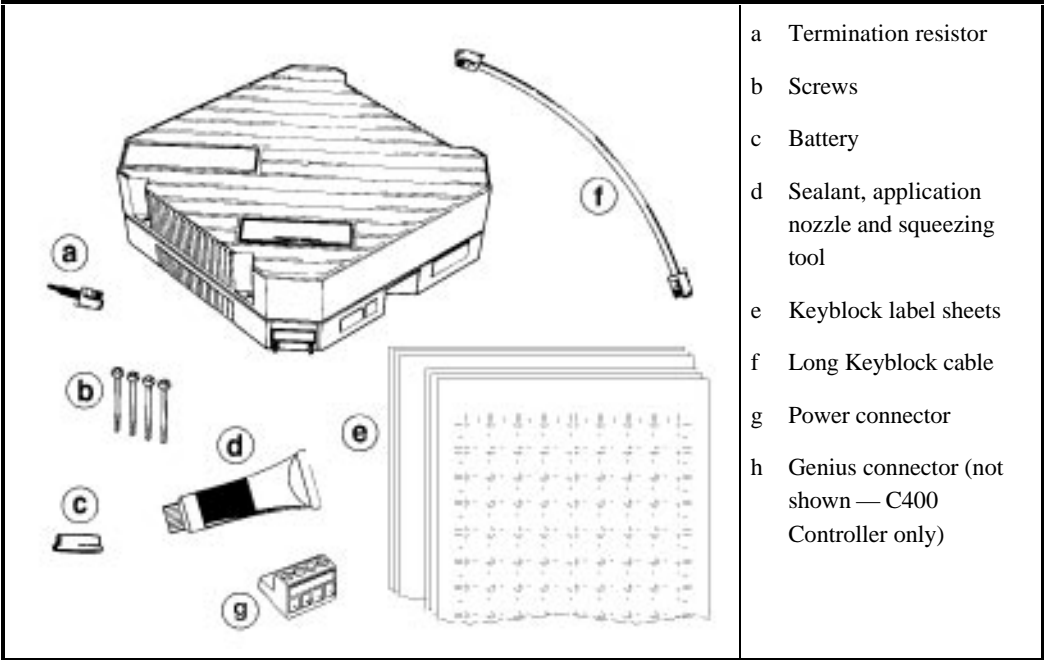

- a Termination resistor
- b Screws
- c Battery
- d Sealant, application nozzle and squeezing tool
- e Keyblock label sheets
- f Long Keyblock cable
- g Power connector
- h Genius connector (not shown — C400 Controller only)

Keyblock Label Insertion/Exchange

The following procedure is for use on an **uninstalled** Keyblock module. To change the label in an installed Panel Keyblock module, the entire unit may need to be disassembled. You may, however, be able to remove the Controller and the cable covers, then continue with the following procedure.

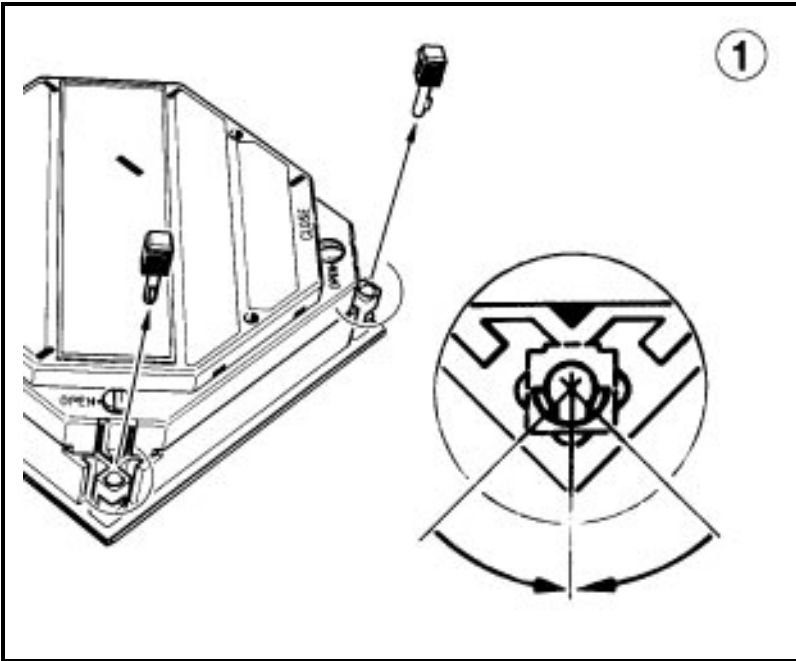
	<p>① Remove mounting pins (if desired) by turning each pin to the middle and pulling up (this is not necessary, but sometimes makes the process easier)/</p>
-------------------------------------------------------------------------------------	--------------------------------------------------------------------------------------------------------------------------------------------------------------

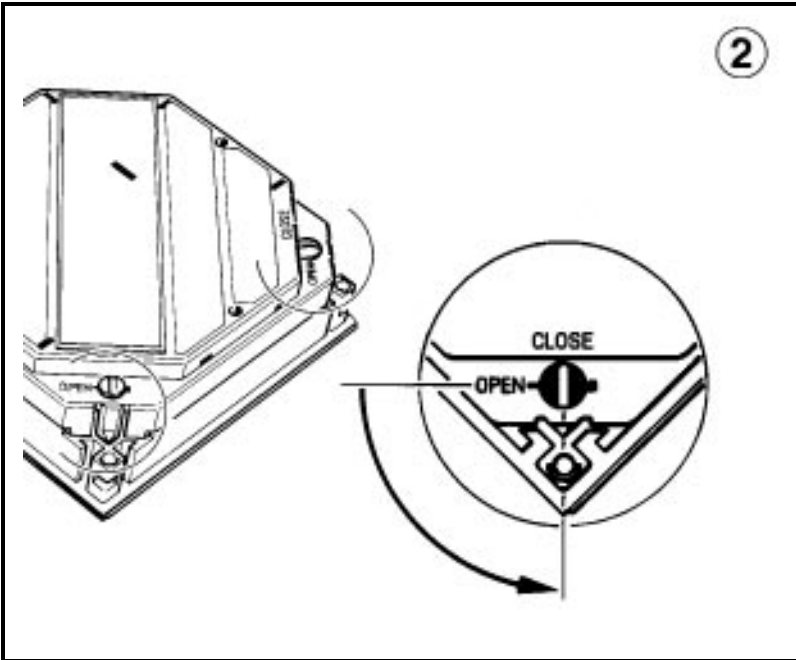
	<p>② Gently turn both screw locks to the OPEN position as shown using a small flathead screwdriver.</p>
--------------------------------------------------------------------------------------	----------------------------------------------------------------------------------------------------------------

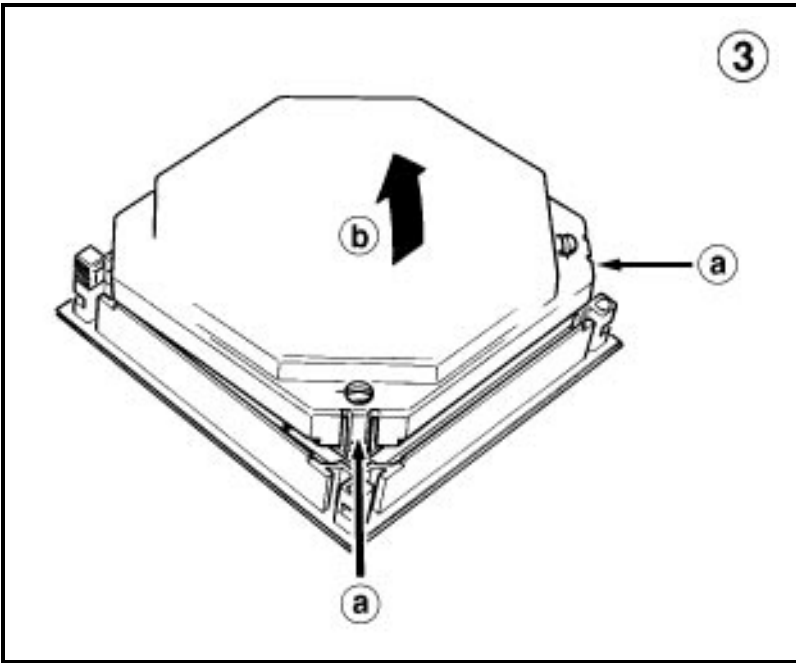
 <p>Diagram 3 shows a top-down view of a square module with a lid. The lid is being lifted upwards, as indicated by a large black arrow labeled 'b'. At the corners of the lid, there are small protrusions labeled 'a'. Arrows point from these labels to the text instructions on the right. A circled number '3' is in the top right corner of the diagram area.</p>	<p>a Press corner locks inward using a small, flathead screwdriver or your finger.</p> <p>b Remove the module bottom by lifting out and up.</p>
-----------------------------------------------------------------------------------------------------------------------------------------------------------------------------------------------------------------------------------------------------------------------------------------------------------------------------------------------------------------------------------------------------------------------------------------------------------	-------------------------------------------------------------------------------------------------------------------------------------------------

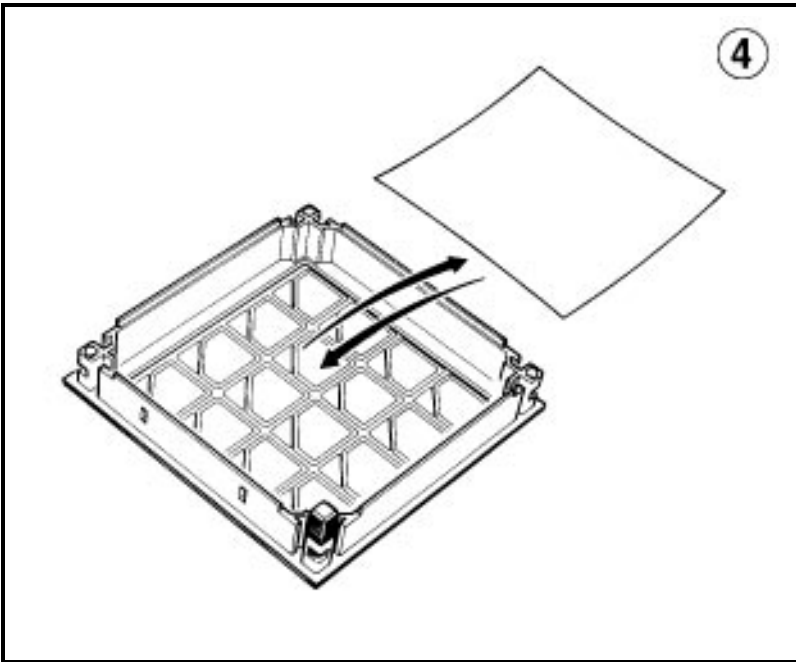
 <p>Diagram 4 shows the underside of the module, which has a grid of key positions. A printed label sheet is being inserted into the grid, as indicated by a curved black arrow. The label sheet is shown as a separate piece above the grid. A circled number '4' is in the top right corner of the diagram area.</p>	<p>Insert/exchange the printed label sheet, making sure the label alignment matches the Keyblock layout, and the key function labels are visible through the keys.</p>
-----------------------------------------------------------------------------------------------------------------------------------------------------------------------------------------------------------------------------------------------------------------------------------------------------------------------------------------------------------------------------------------------------------	------------------------------------------------------------------------------------------------------------------------------------------------------------------------

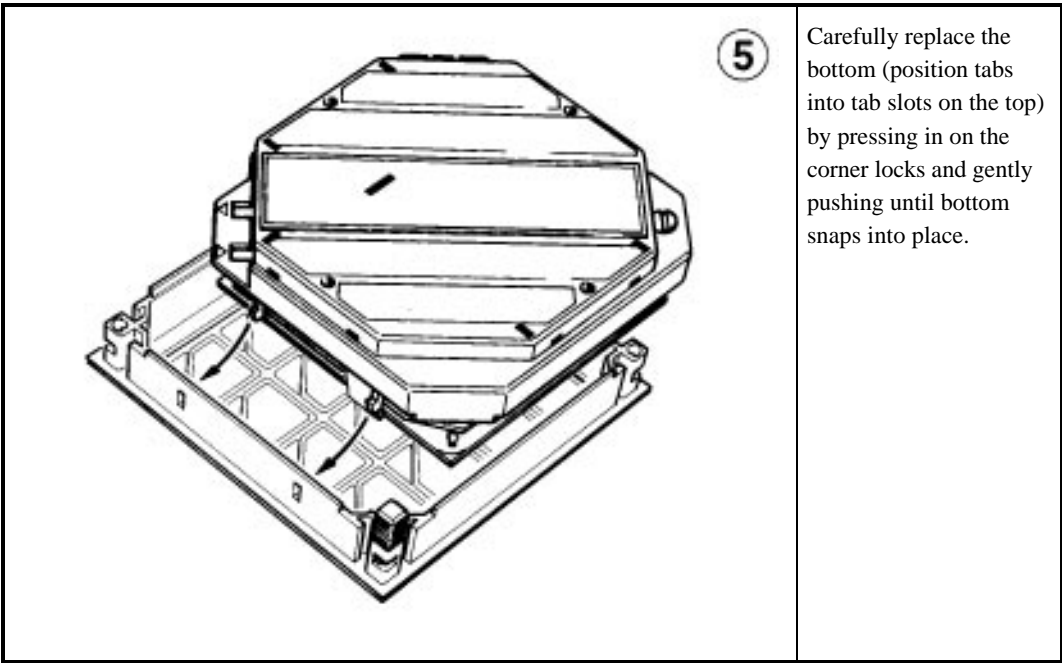

Carefully replace the bottom (position tabs into tab slots on the top) by pressing in on the corner locks and gently pushing until bottom snaps into place.

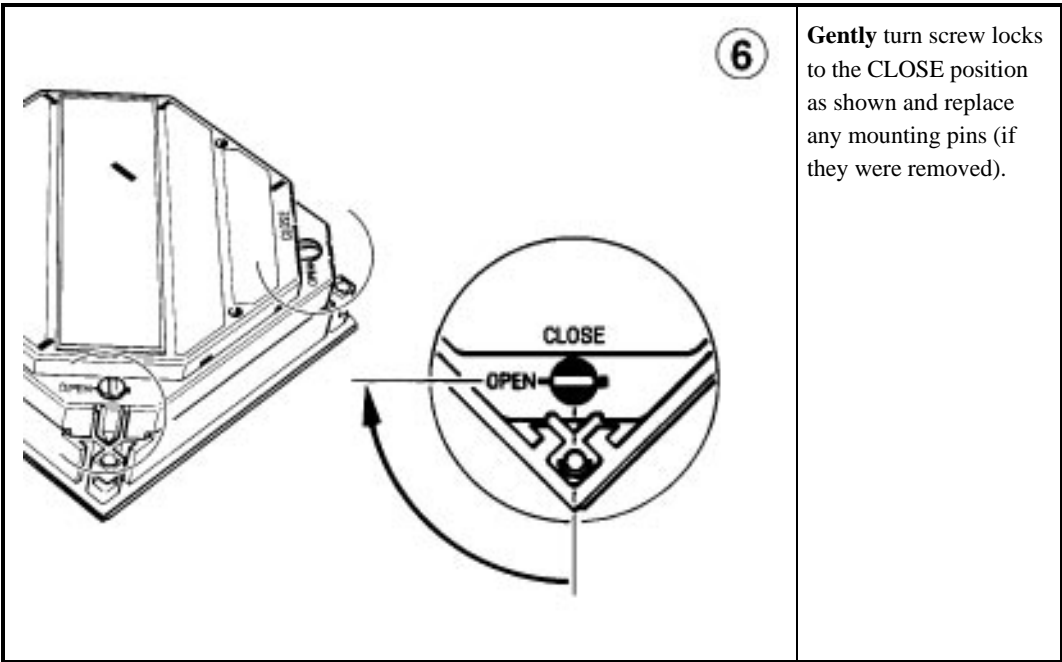

Gently turn screw locks to the CLOSE position as shown and replace any mounting pins (if they were removed).

Installation Procedure

Panel Assembly

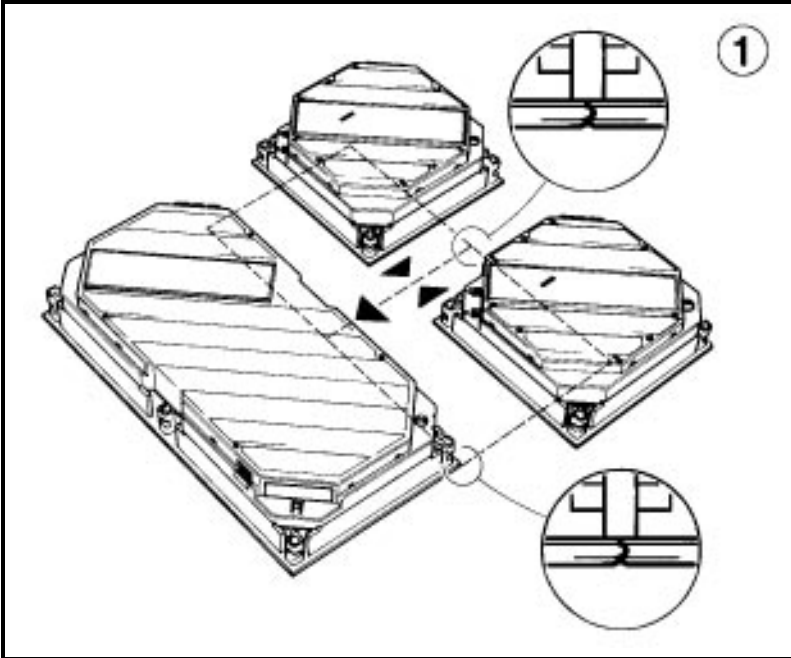

1

Place Keyblock and Display modules upside down in the desired positions on a soft, relatively flat surface, making sure to fit beveled edges together.

The diagonal lines should line up from module to module.

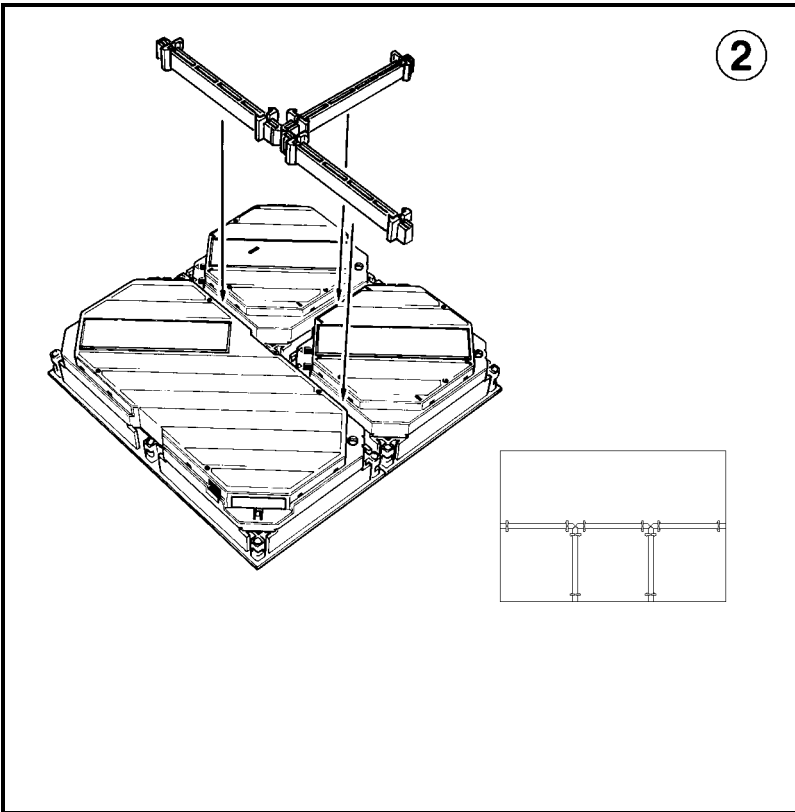

Insert the module connectors between the modules as shown and press firmly into place.

Note:
Two of the module connectors have one flat end and one triangular-shaped end; the third connector has two triangular-shaped ends. Make sure the flat ends of the connectors are located at the edges of the Panel, and the triangular edges meet each other in the middle.

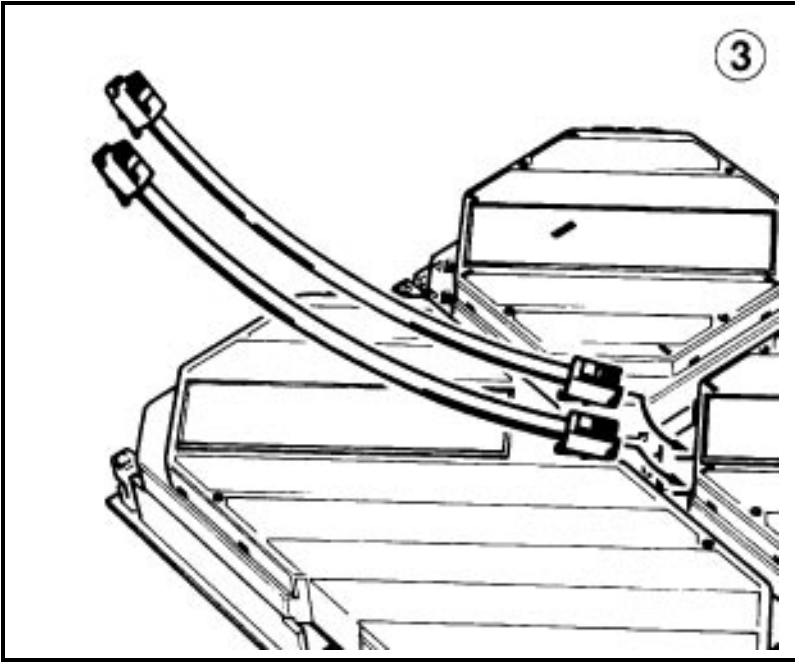

Connect Keyblock cables for the top right module as shown (clips should point down and away) by pushing in until they snap into place. The output from this module should be left unattached to connect to the Panel Controller later.

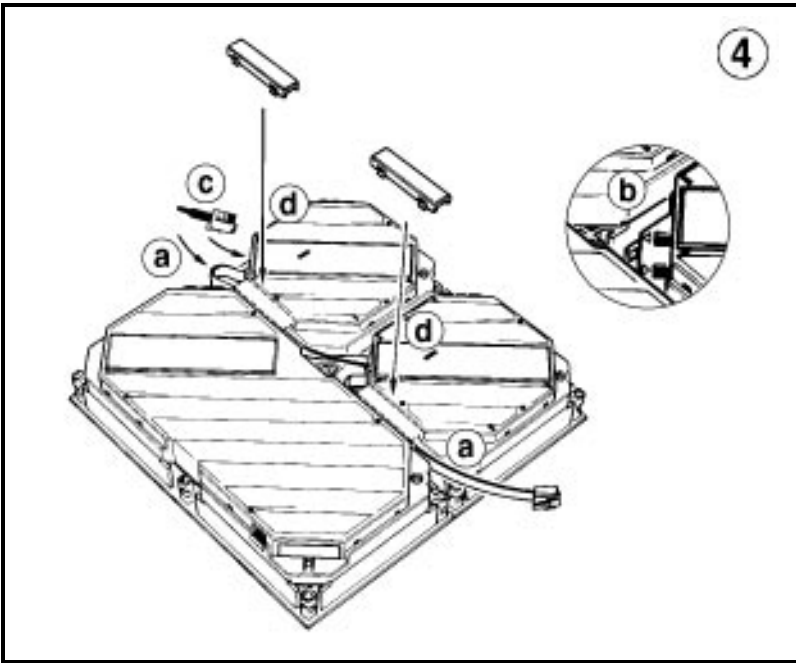

4

- a Connect all Keyblock modules.
- b Use care to connect inputs to outputs and vice versa (see triangular markings).
- c Insert termination resistor into the output of the last Keyblock module.
- d Insert cable covers as shown by lining up the tabs in the middle and gently adjusting until they snap into place.

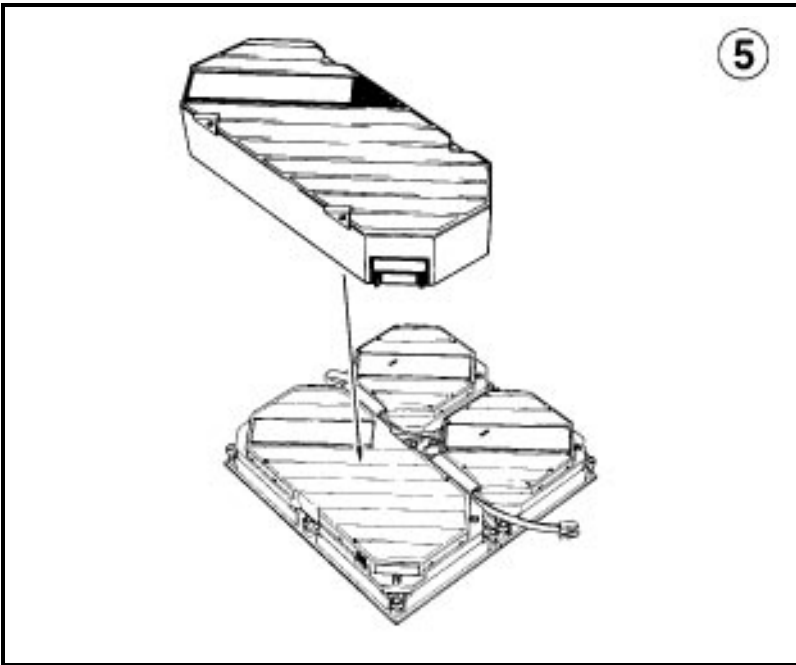

5

Set Controller in place, making sure the ribbon cable connectors from the Controller and the display are aligned atop one another.

Note:
If possible, set number switch settings at this time, before the unit is installed in a Panel.

Note:
Your Controller may have different dimensions from the model shown.

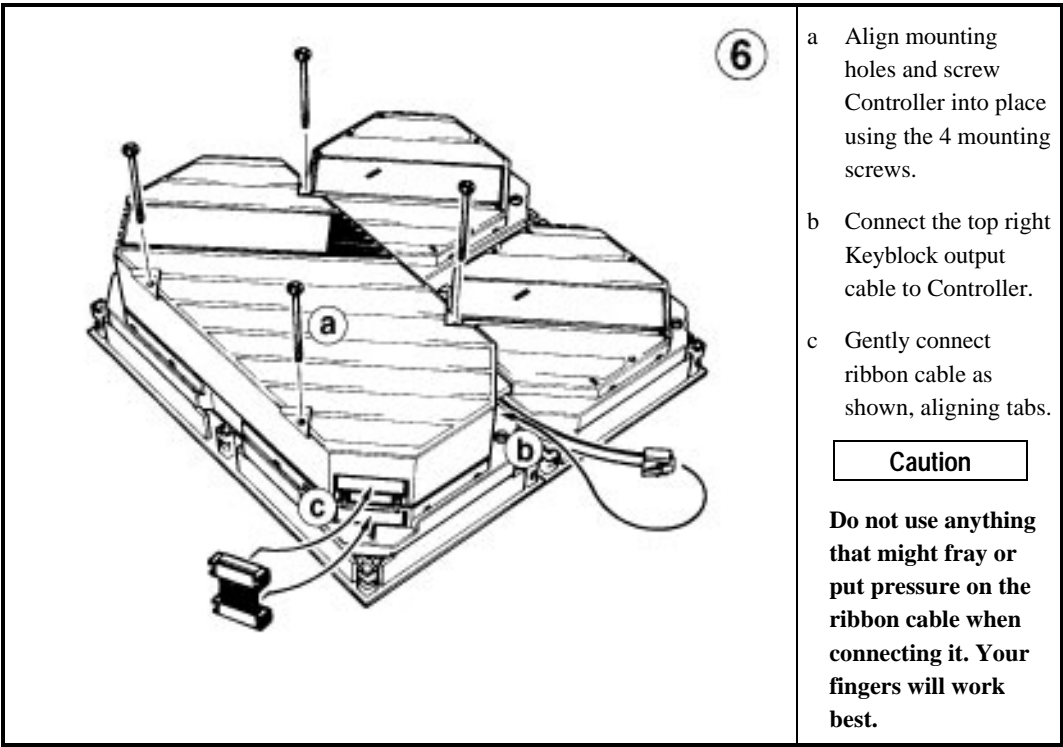

Note

After assembly, the termination resistor connector and the Keyblock cables should not extend beyond the outer edges of the unit.

Once the Panel is assembled, 24V power can be connected.

Panel Installation

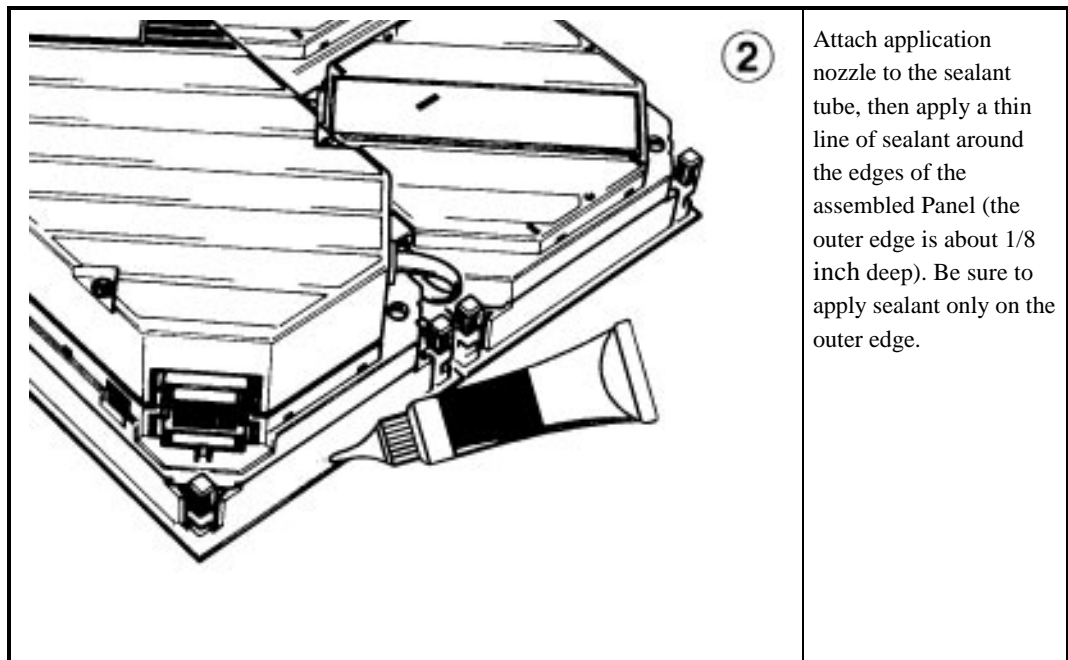
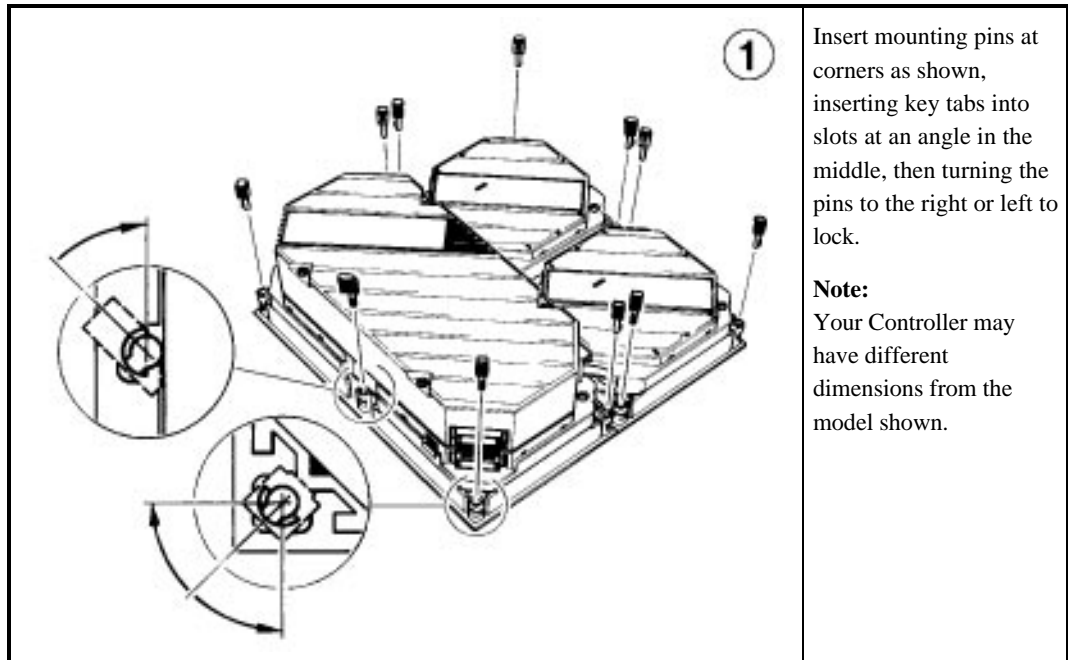

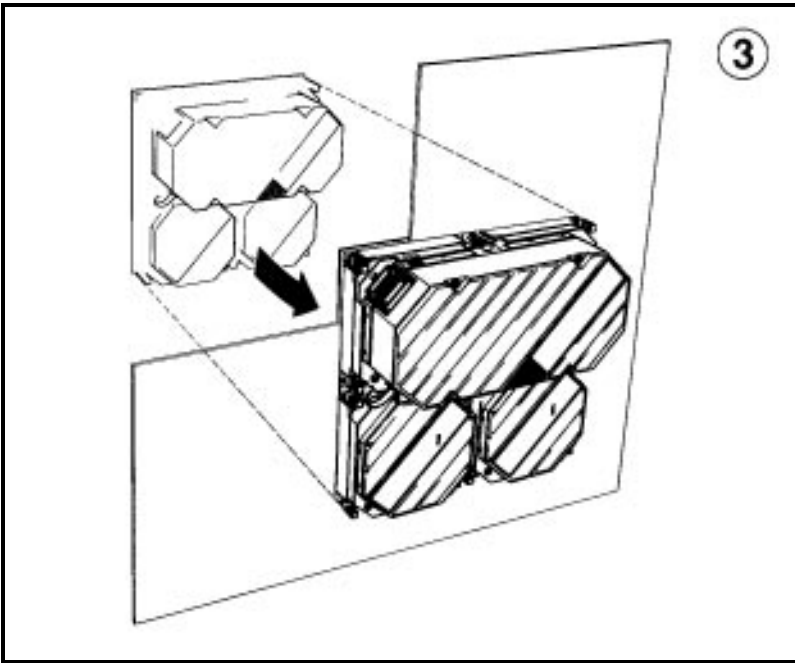

Quickly install Panel in cutout or bezel location (see “Installation Options” in this chapter) by pushing Panel through the front of the cutout or bezel and pressing on edges to make a seal.

Note:
Sealant curing time is 2 hours at room temperature.

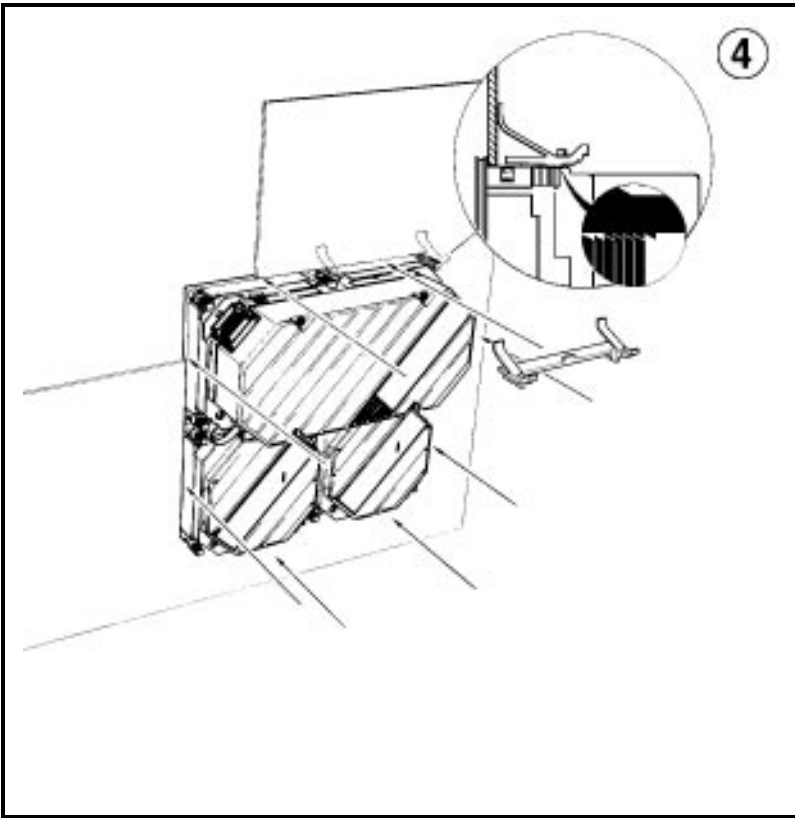

- a Install spring clips around edges of unit as shown by aligning grooves with tabs and pushing until the clips snap into place.
- b If the Panel is mounted in a bezel, apply sealant around the outer edges and bolts, then bolt the entire assembly into the cutout.

Note:
If a gasket is placed between the bezel and the cutout, do not apply sealant to either the gasket or the bezel.

- c Connect 24 V power to the unit.

Panel Removal

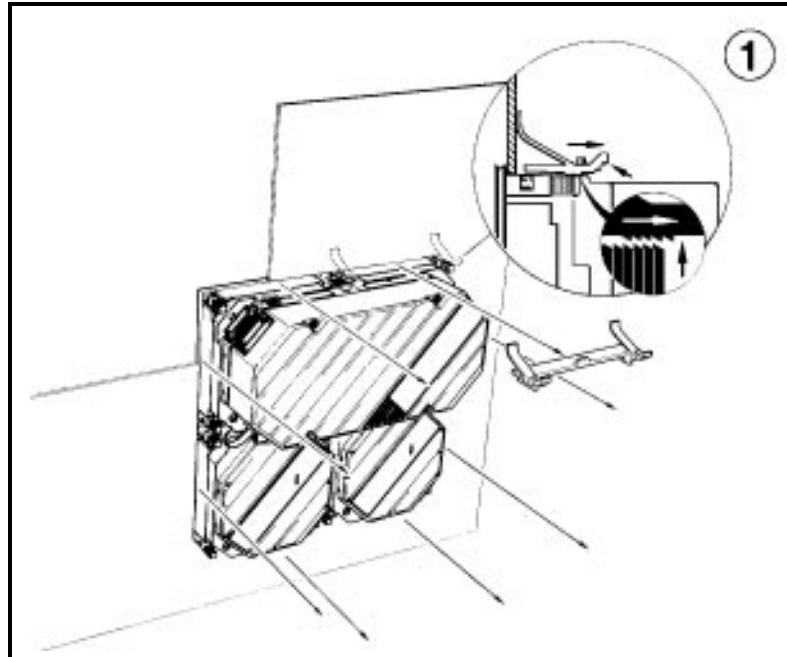

Carefully remove spring clips by pulling out with fingers or prying loose using a small screwdriver.

Caution

Take care not to break plastic parts during Panel removal.

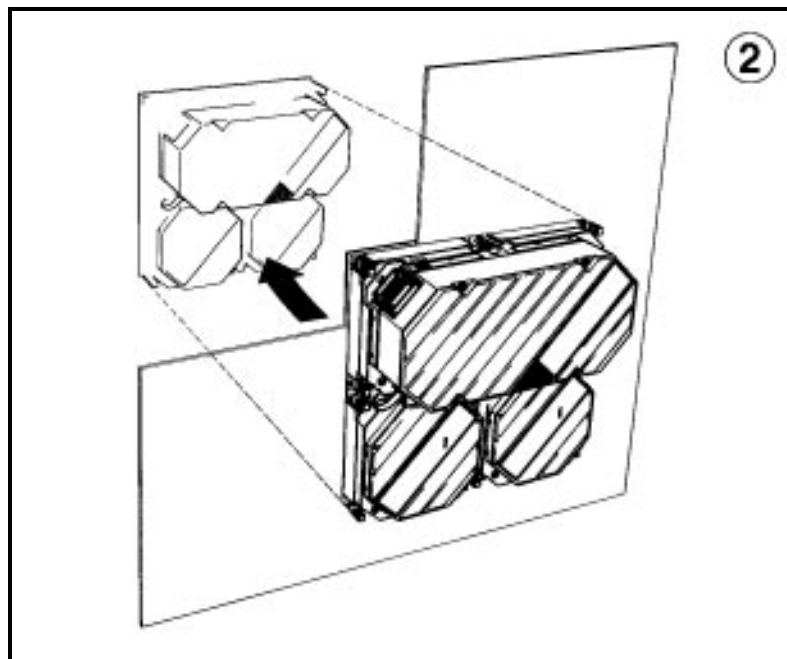

Remove Panel from cutout location or bezel by pushing firmly on the back of unit and gently prying up the sealed edges.

Note:

If the Panel is installed in a bezel, the mounting bezel may need to be removed from the cutout as described above.

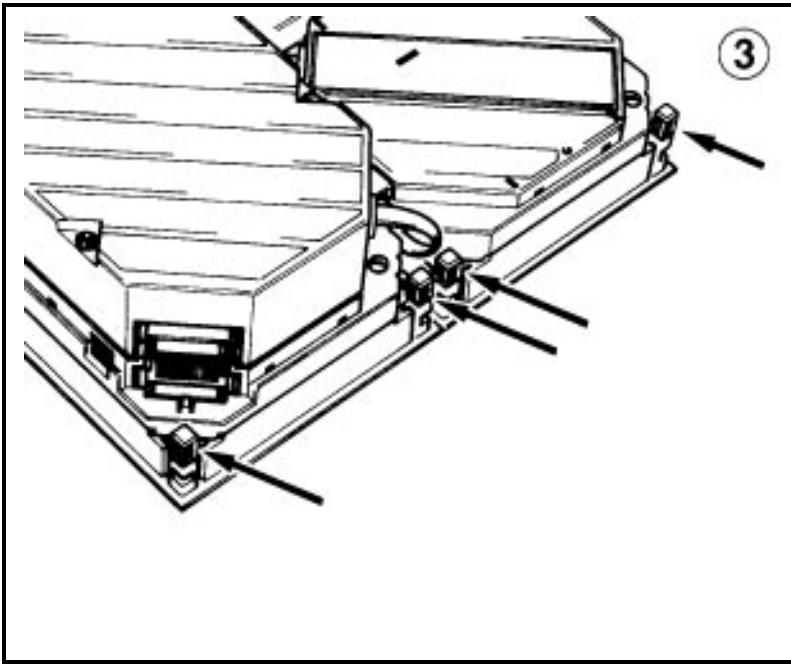

DO NOT remove mounting pins.

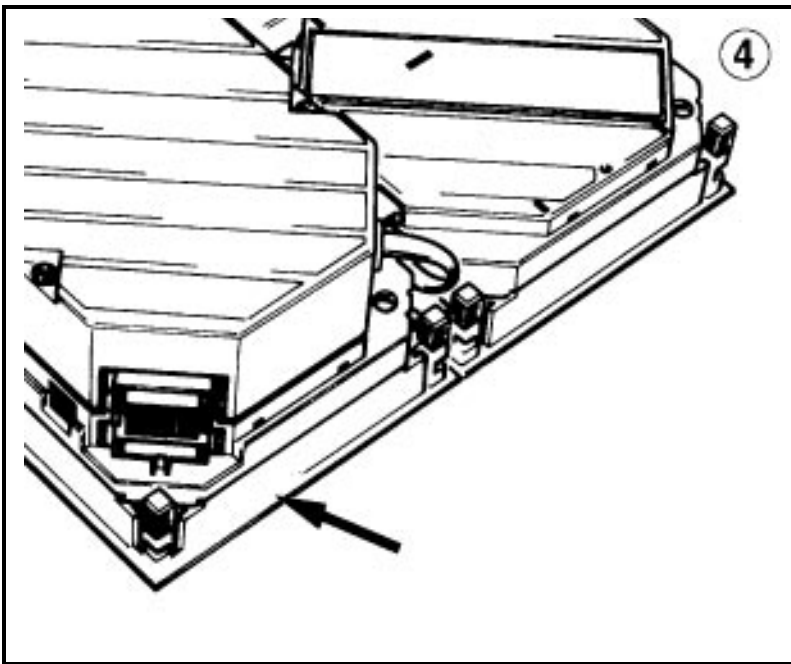

Before reinstalling the Panel, remove remaining sealant from around Panel and cutout (or bezel) edges using a spatula, a rag, or paper.

Note:
Remember to apply new sealant before reinstalling the unit.

Panel Disassembly

Caution

Use extreme care when removing plastic parts. Plastic may break if force is used.

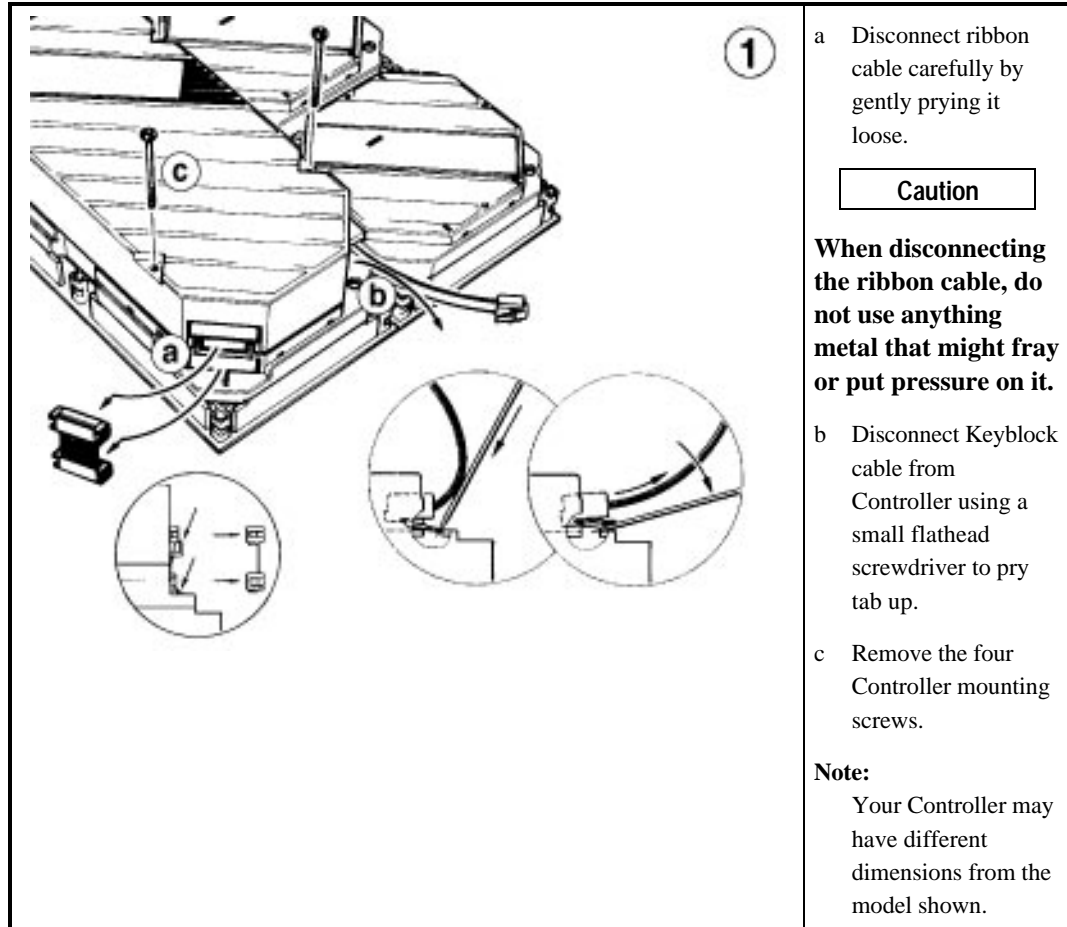

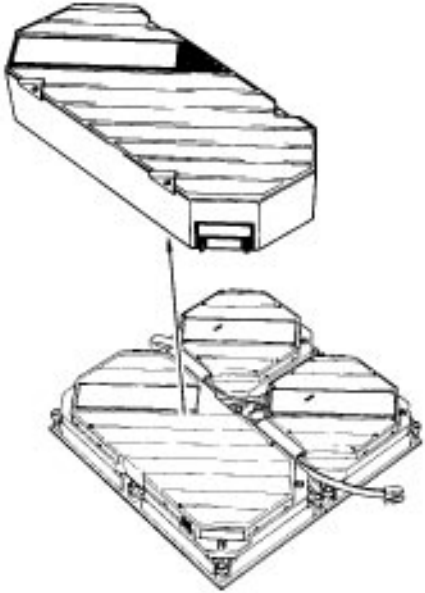

② Remove Controller and set aside.

Note:
The metal Controller screws self-tap into plastic and can only be removed a limited number of times before the plastic will begin to lose grip.

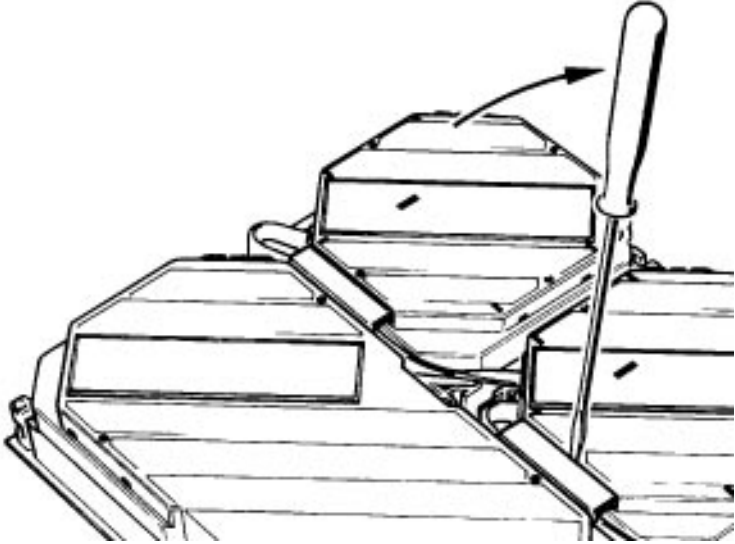

③ Remove cable covers using a small flathead screwdriver to pry them loose.

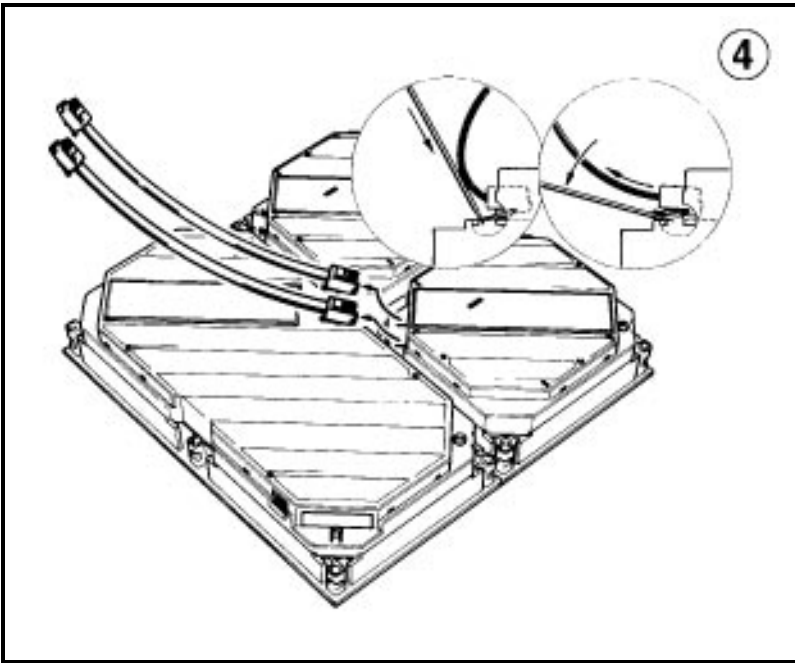

Disconnect and remove remaining Keyblock cables and the termination resistor using a small flathead screwdriver to pry tabs up.

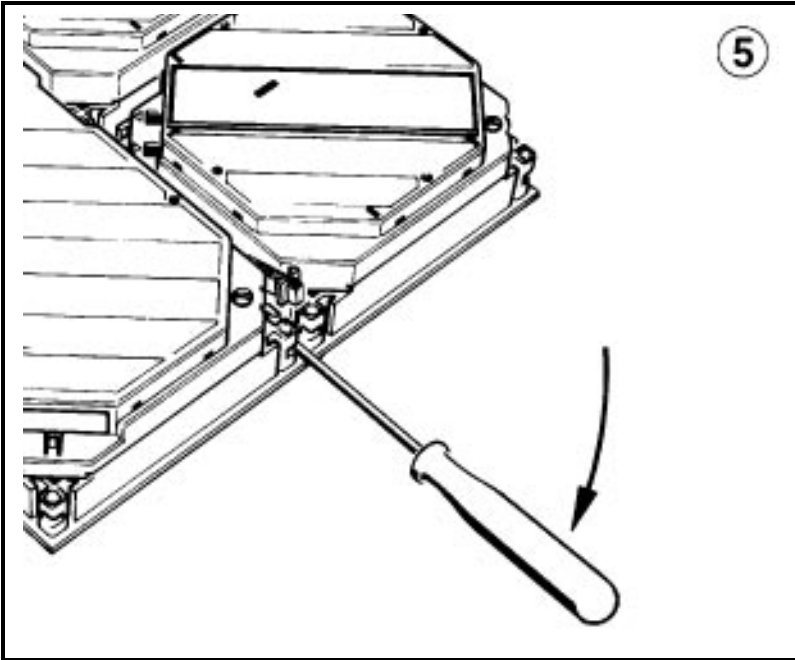

Remove module connectors using a small flathead screwdriver to pry them up.

Controller Battery Installation/Replacement

Each Controller is delivered with a lithium battery in a plastic bag inside the box. This battery should be installed before unit operation and replaced every two years (or as needed).

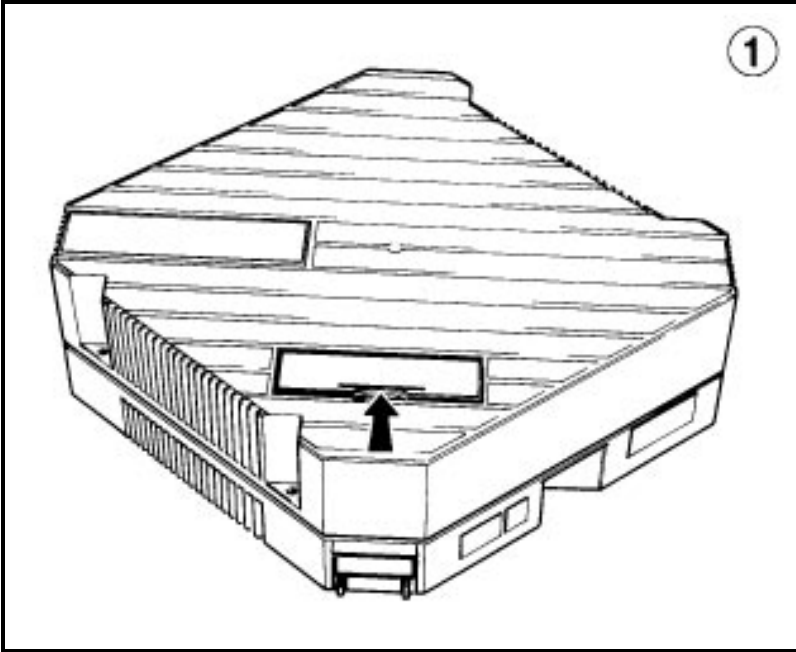
	<p>① Remove the battery cover on the back of the Controller by inserting a fingernail into the slot and pushing back to lift cover off.</p>
-------------------------------------------------------------------------------------	---------------------------------------------------------------------------------------------------------------------------------------------

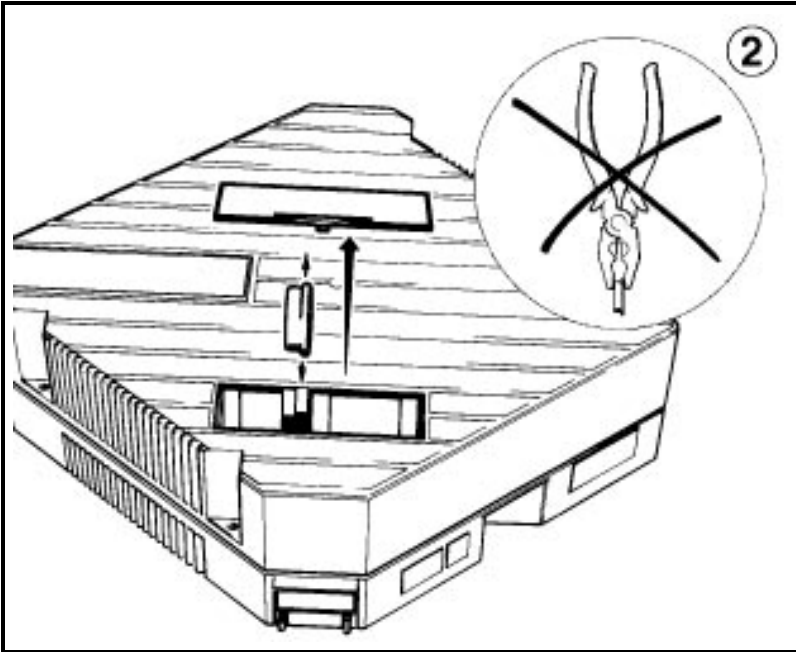
	<p>② Install/exchange battery using fingers; do not touch battery with a conductive device.</p> <p>Use the following battery type.</p> <p>RENATA CR2477N; GE catalog number IC750ACC002.</p> <p>Note: Dispose of old battery in accordance with the MSDS sheet provided.</p>
--------------------------------------------------------------------------------------	---------------------------------------------------------------------------------------------------------------------------------------------------------------------------------------------------------------------------------------------------------------------------------------------

Chapter 3

Display Modules: Overview

This chapter describes the various PANELWARE Display Modules and explains how to connect them. It provides the following information:

- General Information 3-2
 - Backlight (LCD Displays Only) 3-2
 - Contrast (LCD Displays Only) 3-2
 - Connection to the Panel Controller 3-3
- Display Modules with LCD Displays 3-4
 - Display Module 2 x 20 LCD 3-4
 - Display Module 4 x 20 LCD 3-5
 - Display Module 4 x 40 LCD 3-6
 - Display Module 8 x 40 LCD 3-7
- Display Modules with VFD Displays 3-8
 - Display Module 2 x 20 VFD 3-8
 - Display Module 2 x 40 VFD 3-9
- Accessories 3-10

General Information

Backlight (LCD Displays Only)

All LCD Display Modules are equipped with backlights as described below.

Table 3 - 1. Backlights on Display Modules

Display Module	Backlight	Color
Display Module 2 x 20 LCD; 2 x 40 LCD; 4 x 40 LCD	LED-Back Lit	Black on yellow
Display Module 8 x 40 LCD	CFL-Back Lit	Black on white

Contrast (LCD Displays Only)

All LCD Display Modules are equipped with a potentiometer for adjusting screen contrast. The contrast adjustment is located on the top of the module (see view A). For best results, contrast adjustments should be made after the display has warmed up but before the display is mounted in a unit. Turn the potentiometer gently.

Caution

Use a very small Phillips-head screwdriver to adjust the potentiometer. Do not push on the potentiometer because it may come loose from the board.

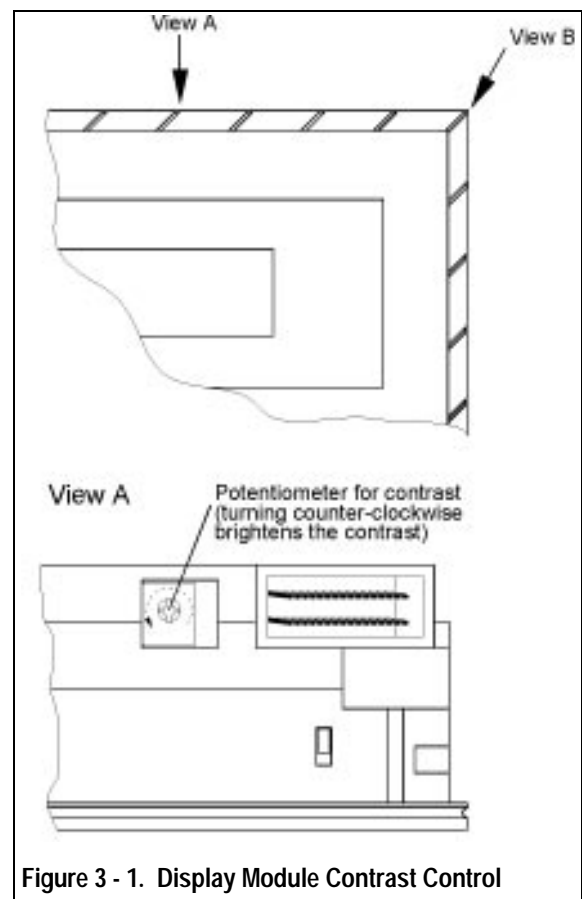

Figure 3 - 1. Display Module Contrast Control

Connection to the Panel Controller

A connector on the top right-hand side of the module allows connection to the Panel Controller (see view B). A ribbon cable is delivered with every Display Module.

Caution

You must use the ribbon cable provided. Do not try to use a longer, different ribbon cable.

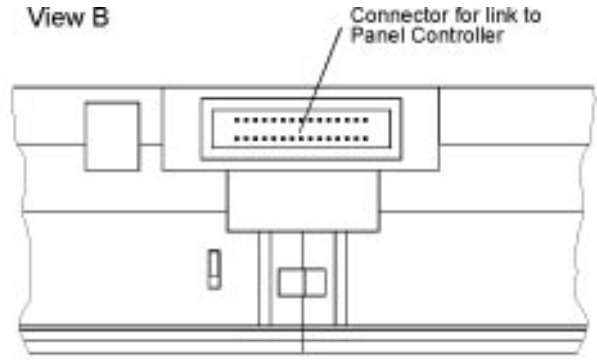

Figure 3 - 2. Display Module Connection to Panel Controller

Caution

During operation, do not disconnect the ribbon cable that connects the Display Module to the Panel Controller. When connecting or disconnecting the ribbon cable, do not use anything that might fray or put pressure on the cable.

Be sure power is off before connecting or disconnecting the ribbon cable.

Display Modules with LCD Displays

Display Module 2 x 20 LCD

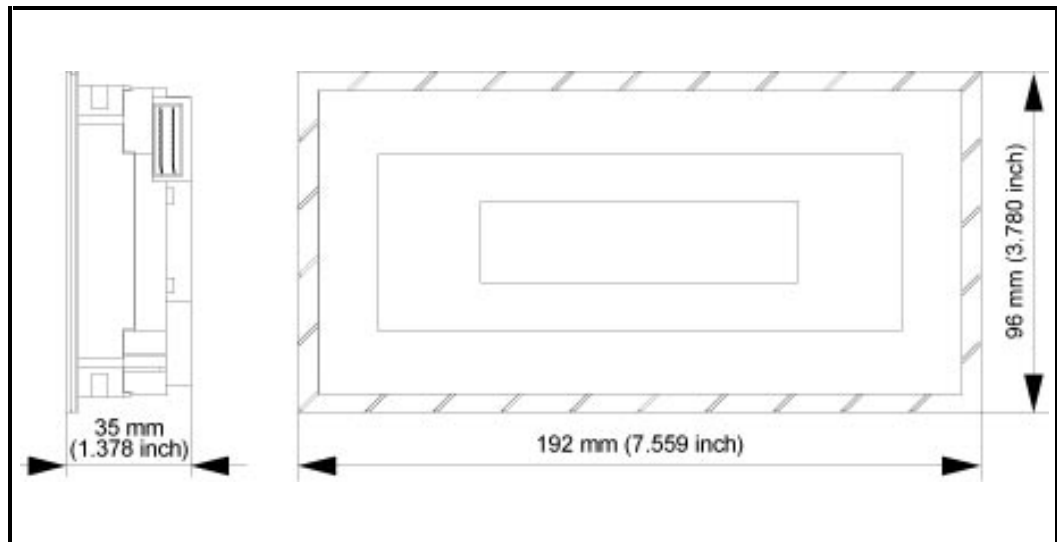

Figure 3 - 3. Display Module with 2 X 20 LCD

Table 3 - 2. Specifications for Display Module with 2 X 20 LCD

Catalog number	IC750LCD220
Display type	LCD
Lines x characters	2 x 20
Character height	5.0 mm (0.1969 inch)
Background lighting	LED
Color	black on yellow
Temperature	
Operating	0 to 50 °C (32 to 122 °F)
Storage	-20 to 60 °C (-4 to 140 °F)
Relative humidity	
Operating	10 to 90 % (non-condensing)
Storage	10 to 90 % (non-condensing)
Shock	conforms to IEC 68-2-27 15g equivalent, 150 m/sec ² , 11 msec, 3 axes (positive and negative)
Vibration	conforms to IEC 68-2-6 1g equivalent, 10-58 Hz; 0.075 mm 58-150 Hz; 9.8m/sec ² 20 cycles per axis
24 VDC power requirements	100 mA
Sealing	NEMA 12 and IP54, when properly mounted in a panel
Noise immunity	conforms to IEC 801.2; IEC 801.3; IEC 801.4

Display Module 4 x 20 LCD

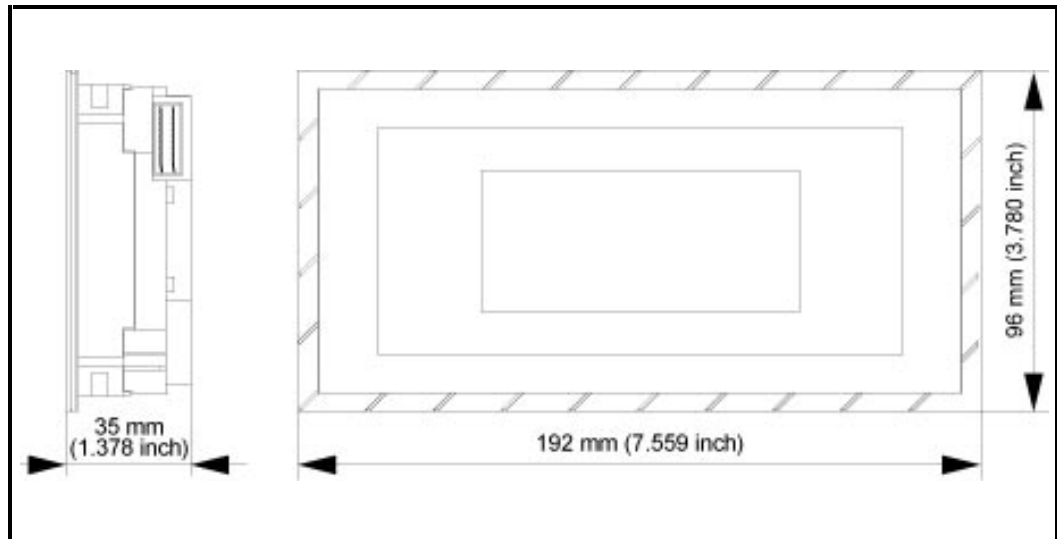

Figure 3 - 4. Display Module with 4 X 20 LCD

Table 3 - 3. Specifications for Display Module with 4 X 20 LCD

Catalog number	IC750LCD420
Display type	LCD
Lines x characters	4 x 20
Character height	8.0 mm (0.3150 inch)
Background lighting	LED
Color	black on yellow
Temperature	
Operating	0 to 50 °C (32 to 122 °F)
Storage	-20 to 60 °C (-4 to 140 °F)
Relative humidity	
Operating	10 to 90 % (non-condensing)
Storage	10 to 90 % (non-condensing)
Shock	conforms to IEC 68-2-27 15g equivalent, 150 m/sec 11 msec, 3 axes (positive and negative)
Vibration	conforms to IEC 68-2-6 1g equivalent, 10-58 Hz; 0.075 mm 58-150 Hz; 9.8m/sec ² 20 cycles per axis
24 VDC power requirements	200 mA
Sealing	NEMA 12 and IP54, when properly mounted in a panel
Noise immunity	conforms to IEC 801.2; IEC 801.3; IEC 801.4

Note

If the front panel of the display is touched immediately after power-up, black lines may appear on the display temporarily. This effect is minimal after the display has warmed up.

Display Module 4 x 40 LCD

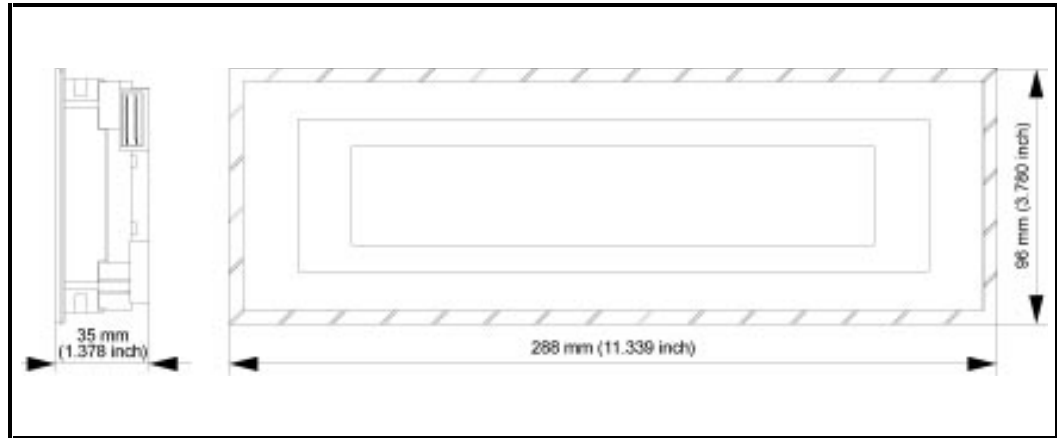

Figure 3 - 5. Display Module with 4 X 40 LCD

Table 3 - 4. Specifications for Display Module with 4 X 40 LCD

Catalog number	IC750LCD440
Display type	LCD
Lines x characters	4 x 40
Character height	4.3 mm (0.1693 inch)
Background lighting	LED
Color	black on yellow
Temperature	
Operating	0 to 50 °C (32 to 122 °F)
Storage	-20 to 60 °C (-4 to 140 °F)
Relative humidity	
Operating	10 to 90 % (non-condensing)
Storage	10 to 90 % (non-condensing)
Shock	conforms to IEC 68-2-27 15g equivalent, 150 m/sec ² , 11 msec, 3 axes (positive and negative)
Vibration	conforms to IEC 68-2-6 1g equivalent, 10-58 Hz; 0.075 mm 58-150 Hz; 9.8m/sec ² 20 cycles per axis
24 VDC power requirements	250 mA
Sealing	NEMA 12 and IP54, when properly mounted in a panel
Noise immunity	conforms to IEC 801.2; IEC 801.3; IEC 801.4

Display Module 8 x 40 LCD

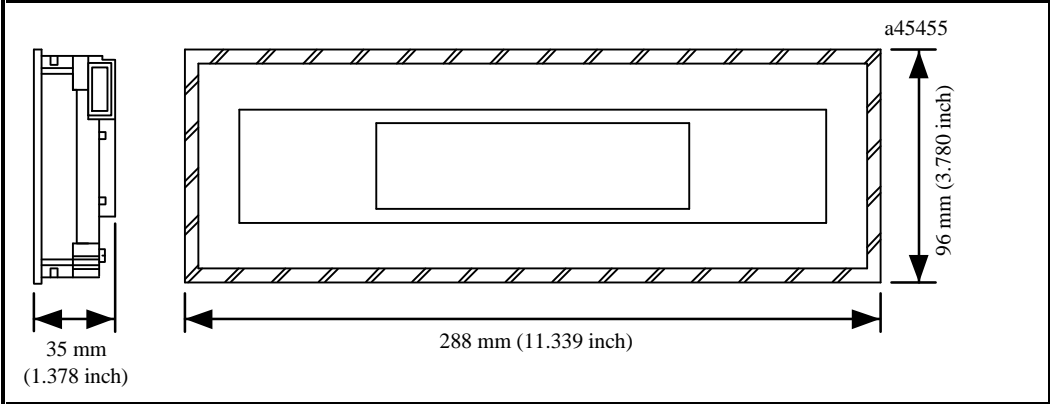

Figure 3 - 6. Display Module with 8 X 40 LCD

Table 3 - 5. Specifications for Display Module with 8 X 40 LCD

Catalog number	IC750CFL840
Display type	LCD, graphics capable
Lines x characters	8 x 40
Pixel Resolution	64 vertical x 240 horizontal (Each character cell consists of 8 x 6 pixels.)
Character height	4.0 mm (0.1575 inch)
Character sizes	single, double and quadruple size
Background lighting	CFL (miniature fluorescent lamp)
Color	black on white
Temperature	
Operating	0 to 50 °C (32 to 122 °F)
Storage	-20 to 60 °C (-4 to 140 °F)
Relative humidity	
Operating	10 to 90 % (non-condensing)
Storage	10 to 90 % (non-condensing)
Shock	conforms to IEC 68-2-27 15g equivalent, 150 m/sec ² , 11 msec, 3 axes (positive and negative)
Vibration	conforms to IEC 68-2-6 1g equivalent, 10-58 Hz; 0.075 mm 58-150 Hz; 9.8m/sec ² 20 cycles per axis
24 VDC power requirements	200 mA
Sealing	NEMA 12 and IP54, when properly mounted in a panel
Noise immunity	conforms to IEC 801.2; IEC 801.3; IEC 801.4

Display Modules with VFD Displays

Display Module 2 x 20 VFD

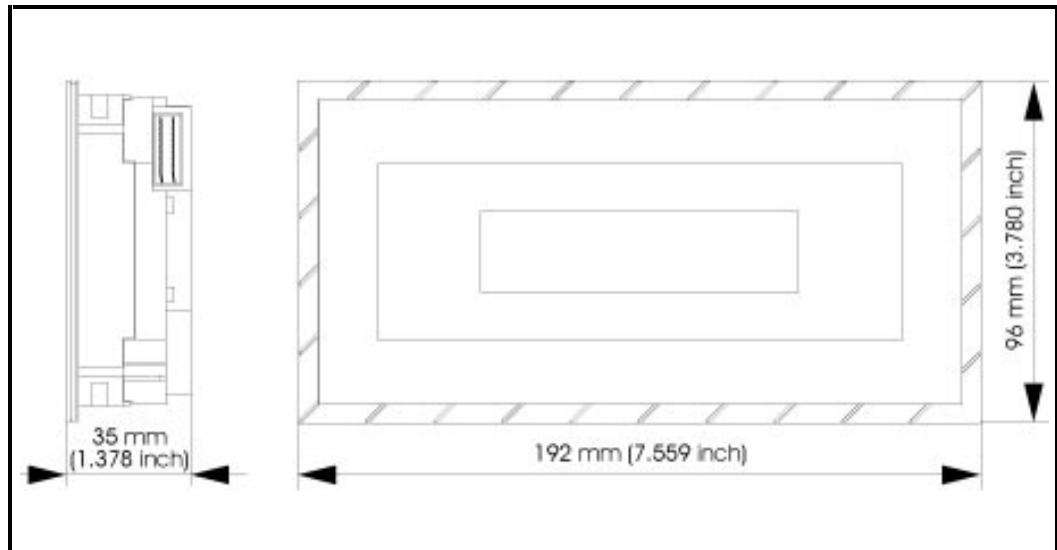

Figure 3 - 7. Display Module with 2 X 20 VFD

Table 3 - 6. Specifications for Display Module with 2 X 20 VFD

Catalog number	IC750VFD220
Display type	VFD
Lines x characters	2 x 20
Character height	5.0 mm (0.1969 inch)
Background lighting	none
Color	green (505 nm)
Temperature	
Operating	0 to 50 °C (32 to 122 °F)
Storage	-20 to 60 °C (-4 to 140 °F)
Relative humidity	
Operating	20 to 85 % (non-condensing)
Storage	20 to 90 % (non-condensing)
Shock	conforms to IEC 68-2-27 15g equivalent, 150 m/sec ² , 11 msec, 3 axes (positive and negative)
Vibration	conforms to IEC 68-2-6 1g equivalent, 10-58 Hz; 0.075 mm 58-150 Hz; 9.8m/sec ² 20 cycles per axis
24 VDC power requirements	200 mA
Sealing	NEMA 12 and IP54, when properly mounted in a panel
Noise immunity	conforms to IEC 801.2; IEC 801.3; IEC 801.4

Display Module 2 x 40 VFD

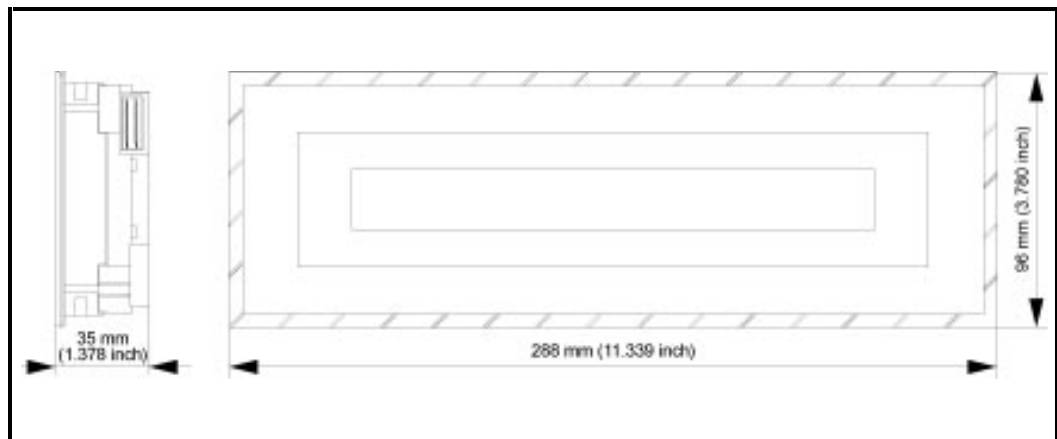

Figure 3 - 8. Display Module with 2 X 40 VFD

Table 3 - 7. Specifications for Display Module with 2 X 40 VFD

Catalog number	IC750LCD240
Display type	VFD
Lines x characters	2 x 40
Character height	5.0 mm (0.1969 inch)
Background lighting	none
Color	green (505 nm)
Temperature	
Operating	0 to 50 °C (32 to 122 °F)
Storage	-20 to 60 °C (-4 to 140 °F)
Relative humidity	
Operating	20 to 85 % (non-condensing)
Storage	20 to 90 % (non-condensing)
Shock	conforms to IEC 68-2-27 15g equivalent, 150 m/sec ² , 11 msec, 3 axes (positive and negative)
Vibration	conforms to IEC 68-2-6 1g equivalent, 10-58 Hz; 0.075 mm 58-150 Hz; 9.8m/sec ² 20 cycles per axis
24 VDC power requirements	200 mA
Sealing	NEMA 12
Noise immunity	conforms to IEC 801.2; IEC 801.3; IEC 801.4

Accessories

Accessory components are required for connecting and installing each Display Module. These accessories are shipped in the same package as the Display Module in the quantities indicated below.

Table 3 - 8. Display Module Accessory Components

Accessory Components	Quantity	
	1 x 2 Display	1 x 3 Display
Ribbon cable (connects Display Module to Panel Controller)	1	1
Spring clips	6	8
Mounting pins	1 bag (4 small, 2 large)	1 bag (4 small, 2 large)
Keyblock cables	N/A	N/A
Module connectors	N/A	N/A

Chapter 4

Keyblock Modules

This chapter explains how to connect the various Keyblock modules to each other and to the Panel Controller in order to create the desired unit. It contains the following information:

- General Information4-2
 - Dimensions.....4-2
 - Standard and Special Keyblock Modules.....4-3
 - Keyblock Labels.....4-3
 - Keyblock Cables4-4
- Standard Keyblock Modules4-5
 - Connection to Panel Controller or to Other Keyblock Modules.....4-5
 - Keyblock Module 16 Keys4-7
 - Keyblock Module Numeric (12+4 Keys)4-8
 - Keyblock Module 8 Keys4-9
 - Keyblock Module 4 Keys4-10
- Special Modules4-11
 - Blank Module4-11
 - Emergency Stop Switch4-12
 - Key Switch4-13
 - Start/Stop.....4-15
- Accessories4-16

General Information

Dimensions

All standard Keyblock modules (and some special modules) have the following (identical) dimensions, regardless of the number/layout of the keys:

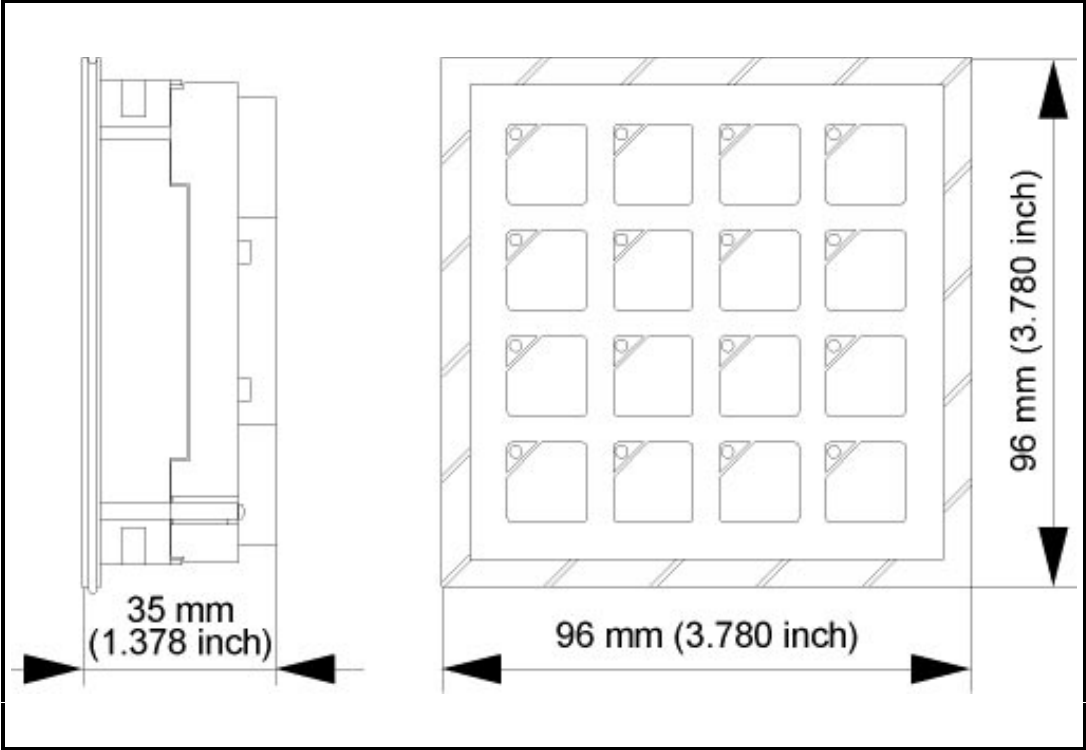

Figure 4 - 1. Keyblock Module Dimensions

Standard and Special Keyblock Modules

Keyblock modules provide keys that are pressed to activate the panel's individual programmed functions. Removable label sheets allow each key to be identified by a name or an icon. If a key has an associated LED, the LED is located in the top left corner.

Keyblock modules are divided into two categories:

- Up to seven *Standard Keyblock Modules* can be cascaded and connected to a Panel Controller.
- *Special Keyblock Modules* are identical in design (and sometimes dimension) to the standard Keyblock modules. They cannot, however, be connected electrically to a Panel Controller or a standard Keyblock module. Special modules must be connected to their respective functions by a qualified electrician (e.g., linking the Emergency Stop switch to the emergency stop security chain).

All panel configurations must be rectangular in shape. Any empty spaces must be filled by blank Keyblock modules.

Note

Configurations that include special modules can not be mounted in a 2 X 2 configuration. In addition, some special Keyblocks will only work in a few physical locations because of their depth. See the descriptions that follow.

Caution

Do not press Keyblock keys with a sharp or pointed object.

Keyblock Labels

Keyblock modules can perform different application functions depending on how the key assignments are programmed. Removable sheets allow you to switch key labels whenever you change the panel program. A separate label sheet can be used for each application, with individual key functions written or typed on the corresponding key template. Each label sheet consists of six perforated legend layouts with triangular cutouts that allow an LED to show through on the Keyblock. Each Keyblock module is shipped with a blank label sheet already in place.

Label sheets come in two sizes—A4 and US letter (8.5 inches X 11 inches). See chapter 6 for information on ordering additional label sheets.

To remove an individual label from a label sheet, locate one of the six perforated squares and tear gently along the perforated lines. Write (using non-smearing ink) or type the desired key functions or identifying icons on the corresponding keys (you may wish to create a word processing template for this function), making sure the writing will be clearly visible from behind the plastic key cover.

Gently insert the label behind the plastic Keyblock cover in the orientation that matches the Keyblock layout. For more instructions on removing or inserting labels, see chapter 2.

Keyblock Cables

Each Keyblock module is shipped with a short Keyblock cable for connecting it to either the Controller or another Keyblock module. The short cable's length is that required to connect one Keyblock module to another when they are side by side.

To accommodate Keyblock configurations that require a longer cable (e.g., two Keyblock modules separated by a blank module), each Controller is shipped with a long (230 mm) Keyblock cable. You may or may not need to use this cable.

Standard Keyblock Modules

Connection to Panel Controller or Another Keyblock Module

Standard Keyblock modules are connected to the Panel Controller or to another Keyblock module using the cable(s) provided (maximum length is 230mm), as shown in figure 4-2. Two telephone connectors on each module (figure 4-3, view A) are indicated as input or output (see view B). An output on the Controller must be connected to an input of a Keyblock module, and so forth. A termination resistor must be plugged into the output connection of the last Keyblock module in the chain.

Warning

Do not connect a Keyblock module input to another Keyblock module input or an output to another output.

Caution

The use of custom length cables is not encouraged. If custom cables are used, their total connection length should not exceed 230 mm.

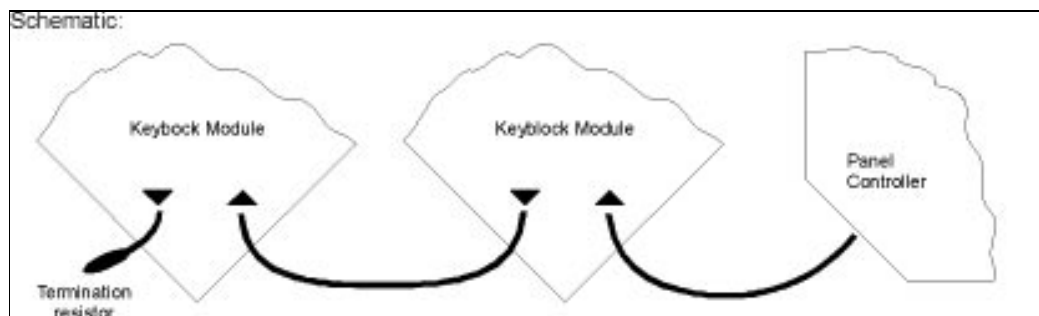

Figure 4 - 2. Keyblock Module Connection Schematic

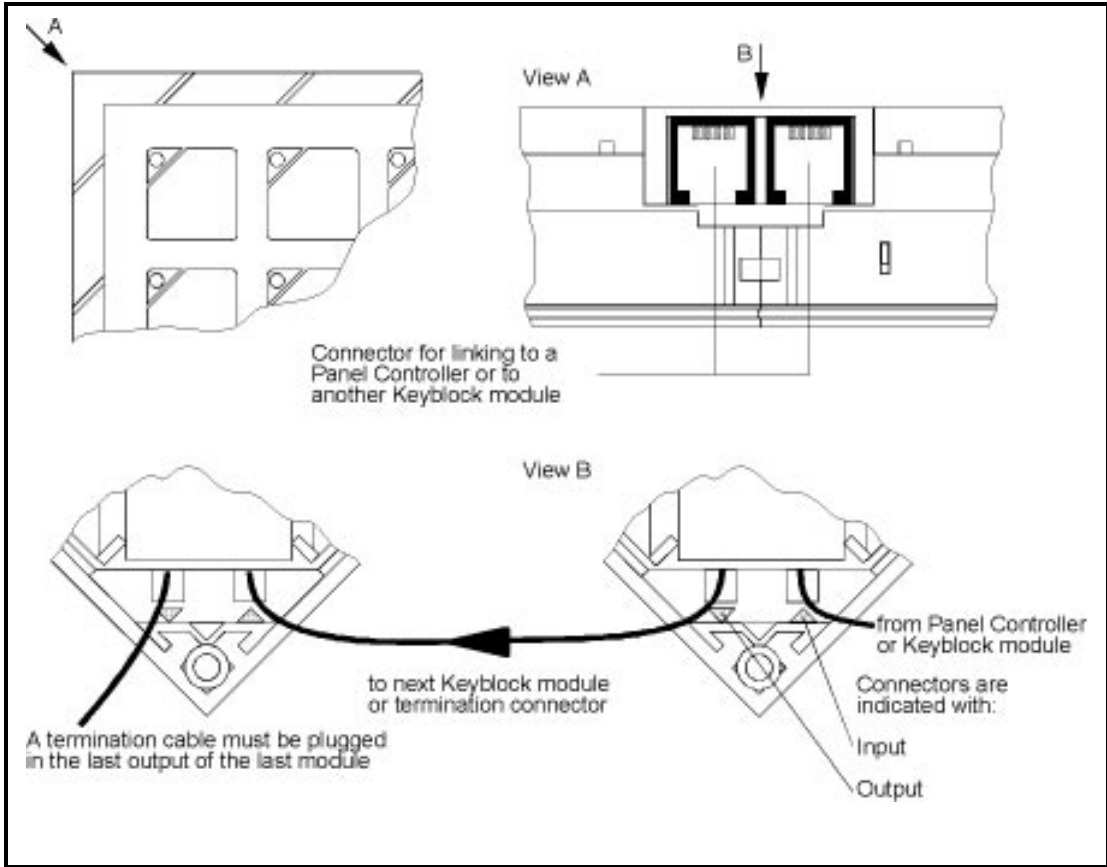

Figure 4 - 3. Keyblock Module Connection Details

Keyblock Module 16 Keys

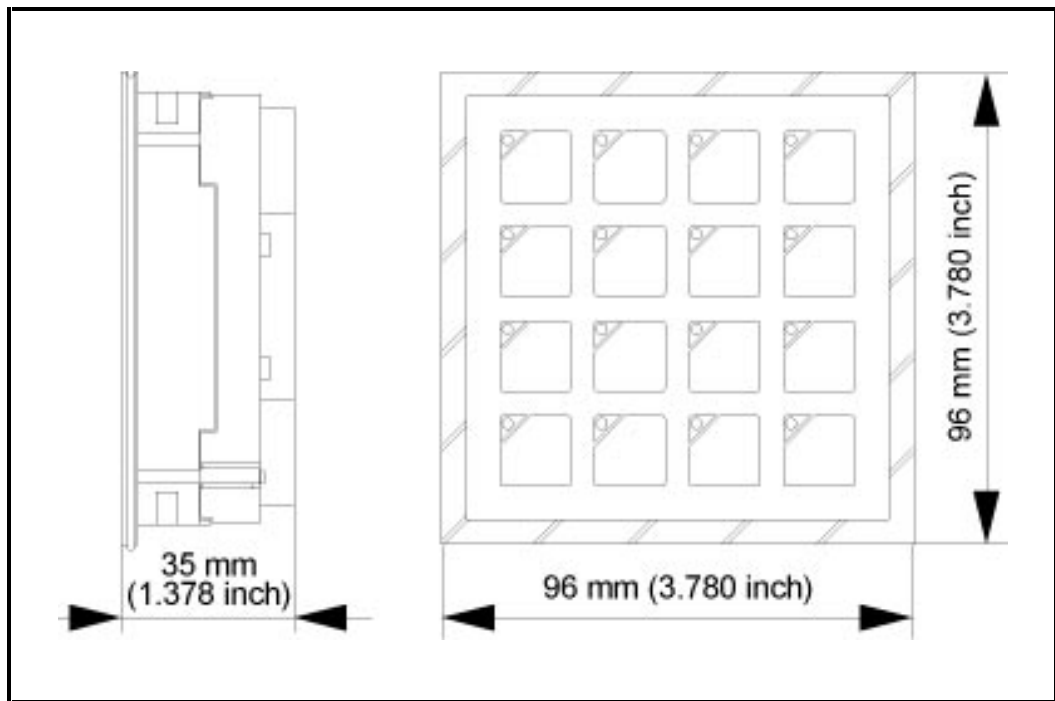

Figure 4 - 4. Keyblock Module with 16 Keys

Table 4 - 1. Specifications for Keyblock Module with 16 Keys

Catalog number	IC750KBL160
Number of keys	16 short-stroke keys
Number of LEDs	16 (yellow)
Labeling	label strips are provided for creating application-specific key labels
Temperature	
Operating	0 to 50 °C (32 to 122 °F)
Storage	-20 to 60 °C (-4 to 140 °F)
Relative humidity	
Operating	5 to 95 % (non-condensing)
Storage	5 to 95 % (non-condensing)
Shock	conforms to IEC 68-2-27 15g equivalent, 150 m/sec ² , 11 msec, 3 axes (positive and negative)
Vibration	conforms to IEC 68-2-6 1g equivalent, 10-58 Hz; 0.075 mm 58-150 Hz; 9.8m/sec ² 20 cycles per axis
24 VDC power requirements	50 mA
Sealing	NEMA 12 and IP54, when properly mounted in a panel
Noise immunity	conforms to IEC 801.2; IEC 801.3; IEC 801.4
Switch rating	rated for 1 million operations, minimum

Keyblock Module Numeric (12+4 Keys)

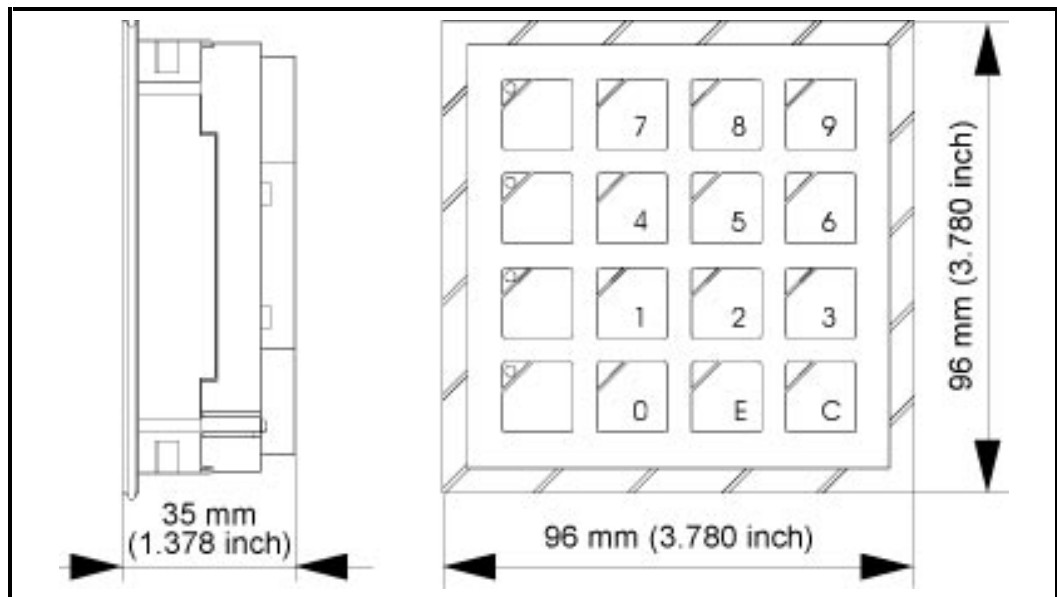

Figure 4 - 5. Keyblock Module Numeric (12+4 Keys)

Note

Your numeric Keyblock module may not have the E and C keys. Instead, the E key (ENTER) may be the ↵ symbol and the C key (CLEAR) may be the ← symbol.

Table 4 - 2. Specifications for Numeric Keyblock Module

Catalog number	IC750KBL400
Number of keys	16 short-stroke keys
Number of LEDs	4 (yellow)
Labeling	12 keys are labeled as a numeric block 4 keys can be labeled using the labels provided
Temperature	
Operating	0 to 50 °C (32 to 122 °F)
Storage	-20 to 60 °C (-4 to 140 °F)
Relative humidity	
Operating	5 to 95 % (non-condensing)
Storage	5 to 95 % (non-condensing)
Shock	conforms to IEC 68-2-27 15g equivalent, 150 m/sec ² , 11 msec, 3 axes (positive and negative)
Vibration	conforms to IEC 68-2-6 1g equivalent, 10-58 Hz; 0.075 mm 58-150 Hz; 9.8m/sec ² 20 cycles per axis
24 VDC power requirements	12 mA
Sealing	NEMA 12 and IP54, when mounted in a panel properly
Noise immunity	conforms to IEC 801.2; IEC 801.3; IEC 801.4
Switch rating	rated for 1 million operations, minimum

Keyblock Module 8 Keys

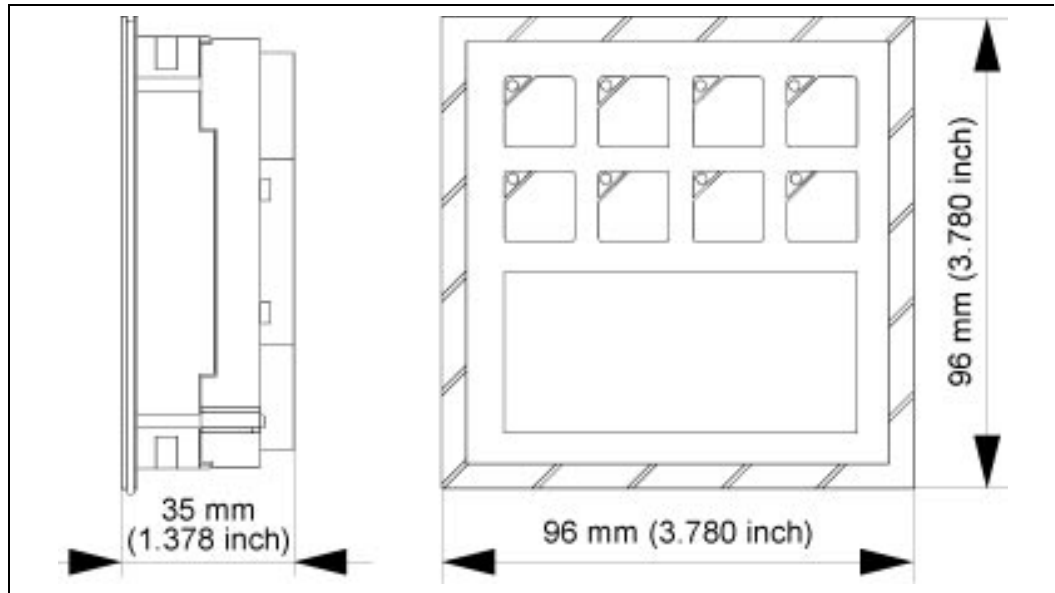

Figure 4 - 6. Keyblock Module with 8 Keys

Table 4 - 3. Specifications for Keyblock Module with 8 Keys

Catalog number	IC750KBL840
Number of keys	8 short-stroke keys
Number of LEDs	4 (yellow) Note: PANELWARE Configuration Software allows configuration of 8 LEDs for this module. This capability is provided for future expansion.
Labeling	label strips are provided for creating application-specific key labels
Label fields	1 field for additional information
Temperature	
Operating	0 to 50 °C (32 to 122 °F)
Storage	-20 to 60 °C (-4 to 140 °F)
Relative humidity	
Operating	5 to 95 % (non-condensing)
Storage	5 to 95 % (non-condensing)
Shock	conforms to IEC 68-2-27 15g equivalent, 150 m/sec ² , 11 msec, 3 axes (positive and negative)
Vibration	conforms to IEC 68-2-6: 1g equivalent, 10-58 Hz; 0.075 mm 58-150 Hz; 9.8m/sec ² 20 cycles per axis
24 VDC power requirements	12 mA
Sealing	NEMA 12 and IP54, when mounted in a panel properly
Noise Immunity	conforms to IEC 801.2; IEC 801.3; IEC 801.4
Switch rating	rated for 1 million operations, minimum

Keyblock Module 4 Keys

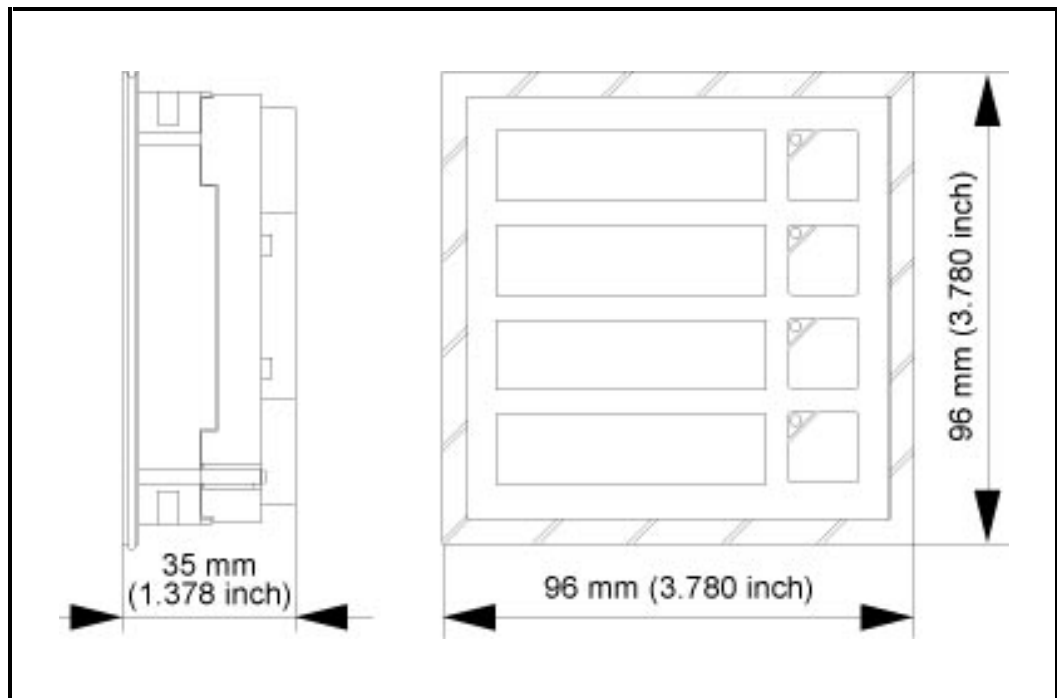

Figure 4 - 7. Keyblock Module with 4 Keys

Table 4 - 4. Specifications for Keyblock Module with 4 Keys

Catalog number	IC750KBL440
Number of keys	4 short-stroke keys
Number of LEDs	4 (yellow)
Labeling	label strips are provided for creating application-specific key labels
Label fields	4 fields for additional information
Temperature	
Operating	0 to 50 °C (32 to 122 °F)
Storage	-20 to 60 °C (-4 to 140 °F)
Relative humidity	
Operating	5 to 95 % (non-condensing)
Storage	5 to 95 % (non-condensing)
Shock	conforms to IEC 68-2-27 15g equivalent, 150 m/sec ² , 11 msec, 3 axes (positive and negative)
Vibration	conforms to IEC 68-2-6 1g equivalent, 10-58 Hz; 0.075 mm 58-150 Hz; 9.8m/sec ² 20 cycles per axis
24 VDC power requirements	12 mA
Sealing	NEMA 12 and IP54, when mounted in a panel properly
Noise immunity	conforms to IEC 801.2; IEC 801.3; IEC 801.4
Switch rating	rated for 1 million operations, minimum

Special Modules

Blank Module

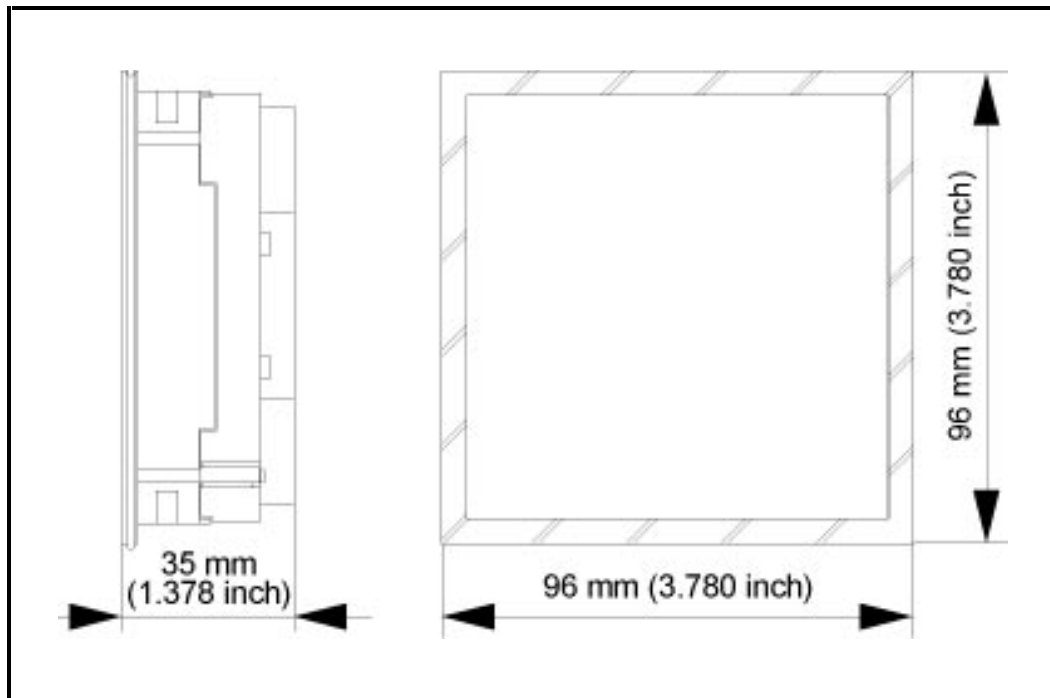

Figure 4 - 8. Blank Keyblock Module

Table 4 - 5. Specifications for Blank Keyblock Module

Catalog number	IC750KBL000
Number of keys	none
Number of LEDs	none
Temperature	
Operating	0 to 50 °C (32 to 122 °F)
Storage	-20 to 60 °C (-4 to 140 °F)
Relative humidity	
Operating	5 to 95 % (non-condensing)
Storage	5 to 95 % (non-condensing)
Shock	conforms to IEC 68-2-27 15g equivalent, 150 m/sec ² , 11 msec, 3 axes (positive and negative)
Vibration	conforms to IEC 68-2-6 1g equivalent, 10-58 Hz; 0.075 mm 58-150 Hz; 9.8m/sec ² 20 cycles per axis
Sealing	NEMA 12 and IP54, when mounted in a panel properly

Emergency Stop Switch

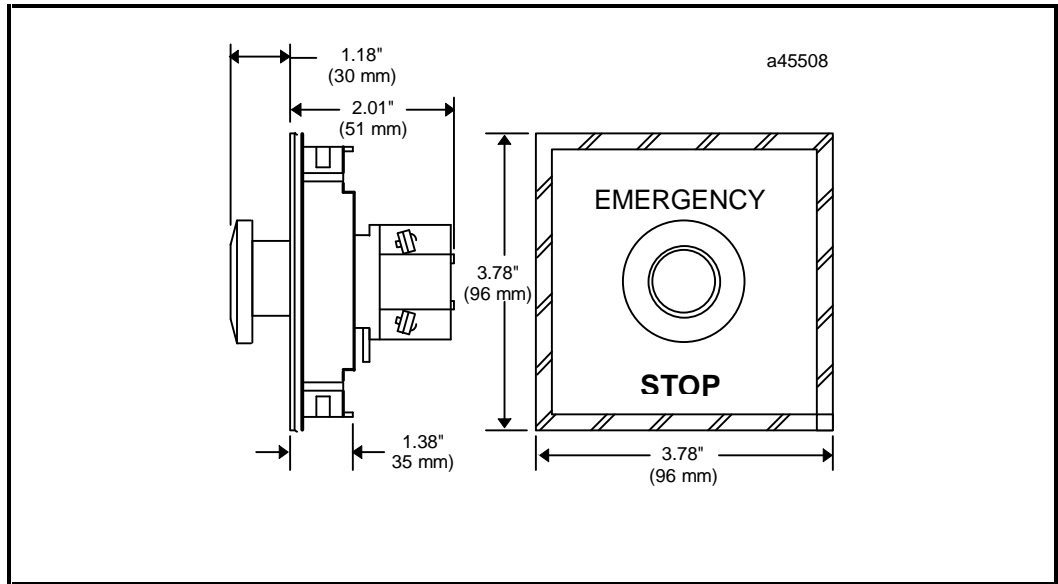

Figure 4 - 9. Emergency Stop Switch Module

Caution

It is not possible to place a Controller directly behind this Keyblock module due to the module's depth.

Table 4 - 6. Specifications for Emergency Stop Switch Module

Catalog number	IC750KBL910
Number of switches	1 EMERGENCY STOP switch
Temperature Operating Storage	0 to 50 °C (32 to 122 °F) -20 to 60 °C (-4 to 140 °F)
Relative humidity Operating Storage	5 to 95 % (non-condensing) 5 to 95 % (non-condensing)
Shock	conforms to IEC 68-2-27 15g equivalent, 150 m/sec ² , 11 msec, 3 axes (positive and negative)
Vibration	conforms to IEC 68-2-6 1g equivalent, 10-58 Hz; 0.075 mm 58-150 Hz; 9.8m/sec ² 20 cycles per axis
Contacts	2 X NORMALLY CLOSED 10 Amps @ 220 VAC; 7.5 Amps @ 380 VAC
Sealing	NEMA 12 and IP54, when mounted in a panel properly
Switch rating	rated for 1 million operations, minimum

Key Switch Module

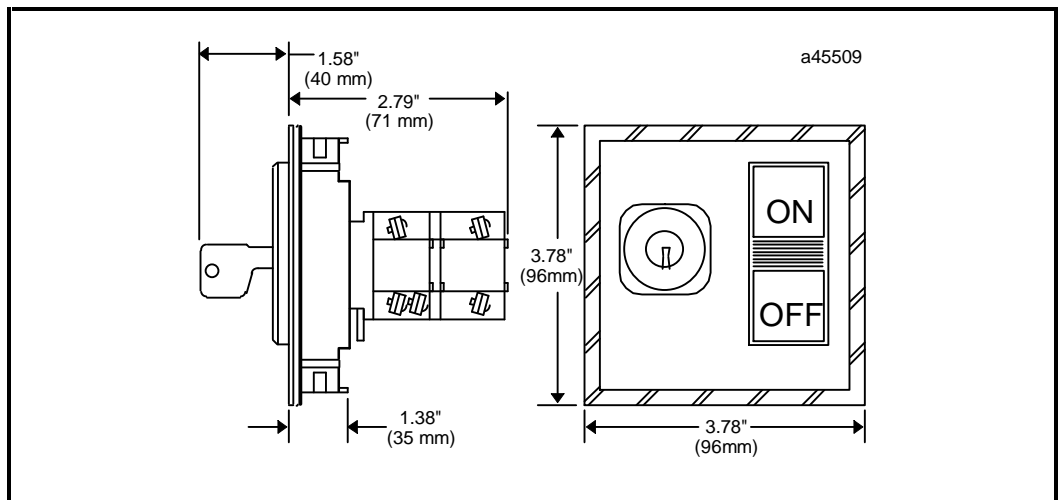

Figure 4 - 10. Key Switch Module

Warning

Revision B and later Key Switch modules *not* interchangeable with revision A Key Switch Modules. Because the type of OFF switch has been changed, the two versions operate differently. If you replace an A version of the module with a B or later version (or vice-versa), you must also modify your system configuration accordingly before powering up.

Revision B	OFF contacts are <i>normally closed</i> and open momentarily when the OFF switch is pressed.
Revision A	OFF contacts are <i>normally open</i> and close momentarily when the OFF switch is pressed

Caution

It is not possible to place a Controller directly behind this Keyblock module due to the module's depth.

Table 4 - 7. Specifications for Key Switch Module

Catalog number	IC750KBL920
Number of switches	1 Key switch 1 ON/OFF switch
Temperature Operating Storage	0 to 50 °C (32 to 122 °F) -20 to 60 °C (-4 to 140 °F)
Relative humidity Operating Storage	5 to 95 % (non-condensing) 5 to 95 % (non-condensing)
Shock	conforms to IEC 68-2-27 15g equivalent, 150 m/sec ² , 11 msec, 3 axes (positive and negative)
Vibration	conforms to IEC 68-2-6 1g equivalent, 10-58 Hz; 0.075 mm 58-150 Hz; 9.8m/sec ² 20 cycles per axis
Contacts	
Key switch	1- NORMALLY CLOSED, 1 - NORMALLY OPEN 10 amps @ 220 VAC; 7.5 amps @ 380 VAC
ON switch	1 NORMALLY OPEN 10 amps @ 220 VAC; 7.5 amps @ 380 VAC
OFF switch	1 NORMALLY CLOSED (Revision B and later — see WARNING on page 4-13) 10 amps @ 220 VAC; 7.5 amps @ 380 VAC
Sealing	NEMA 12 and IP54, when mounted in a panel properly
Switch rating	rated for 1 million operations, minimum

Start/Stop

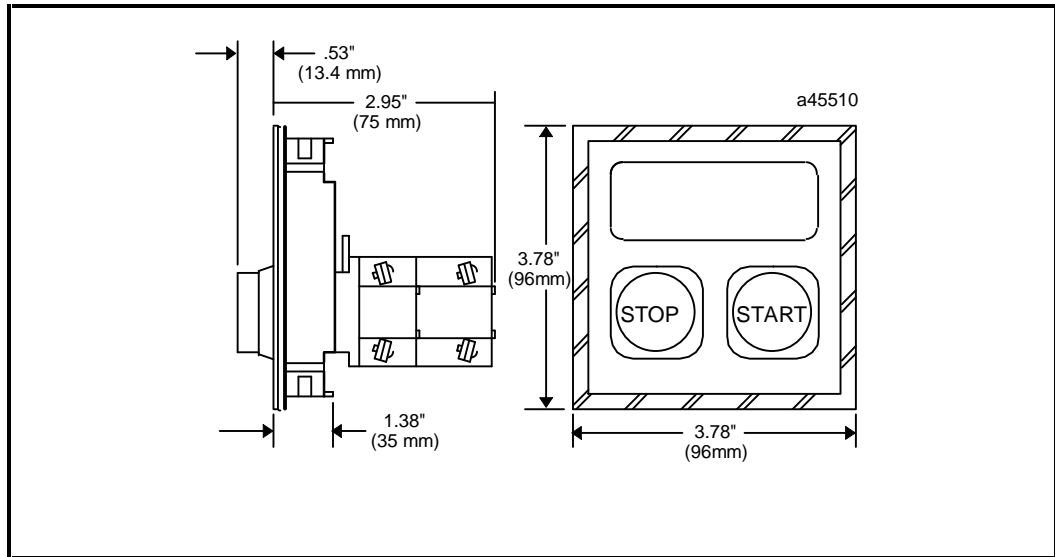

Figure 4 - 11. Start/Stop Module

Caution

It is not possible to place a Controller directly behind this Keyblock module due to the module's depth.

Table 4 - 8. Specifications for Start/Stop Module

Catalog number	IC750KBL930
Number of keys	2 keys (labeled START and STOP)
Labeling	a label strip is provided for creating an application-specific key label
Label fields	1 field for additional information
Relative humidity	
Operating	5 to 95 % (non-condensing)
Storage	5 to 95 % (non-condensing)
Shock	conforms to IEC 68-2-27 15g equivalent, 150 m/sec ² , 11 msec, 3 axes (positive and negative)
Vibration	conforms to IEC 68-2-6 1g equivalent, 10-58 Hz; 0.075 mm 58-150 Hz; 9.8m/sec ² 20 cycles per axis
Contacts	1 - NORMALLY CLOSED, 1 - NORMALLY OPEN 10 Amps @ 220 VAC; 7.5 Amps @ 380 VAC
Sealing	NEMA 12 and IP54, when mounted in a panel properly
Noise immunity	conforms to IEC 801.2; IEC 801.3; IEC 801.4
Switch rating	rated for 1 million operations, minimum

Accessories/Replacement Components

Accessory components are required for connecting and installing each Keyblock module. The accessories are shipped in the same package as the Keyblock module in the quantities indicated in table 4-9. Table 4-10 lists ordering information for replacement lamps.

Table 4 - 9. Keyblock Module Accessory Components

Accessories	Quantity	
	Standard Keyblock Modules	Special Keyblock Modules
Module connectors (one double-nosed and two single-nosed)	3	3
Cable covers	2	2
Short Keyblock cable (connects Panel Controller to Keyblock module, or connects Keyblock module to Keyblock module)	1	---
Spring clips	2	2
Mounting pins	1 bag	1 bag

Table 4 - 10. Replacement Lamps

Type	Catalog Number
24 — 30 VAC, 2 W, BA9S	RAFI 1.90060.133
110 — 130 VAC, 2 W, BA9S	RAFI 1.90060.137

Chapter 5

Panel Controllers

Two Panel Controllers, C200 (basic) and C400 (Genius), are available for use with the PANELWARE system. This chapter presents specifications, connections (interfaces) and describes the hardware configuration for both units. The hardware information for the C400 Panel Controller is duplicated, for your convenience, in the *PANELWARE MMI Application Manual for GE Fanuc Genius Protocol User's Manual* (GFK 1115). Refer to GFK-1115 for additional information about operating the PANELWARE system with Genius protocol. For other protocols, refer to the appropriate *Application Manual* (listed in the “Preface”).

- General Information5-2
 - VDC Power Requirement.....5-2
 - Connecting Power to Controller.....5-2
 - Setting Number Switches.....5-2
- Basic Panel Controller (C200)5-3
 - Specifications5-3
 - Overview of Connections and Operational Elements.....5-4
- Genius Panel Controller (C400).....5-8
 - Specifications5-8
 - Overview of Connections and Operational Elements5-9
- Operating the Panel Controllers.....5-13
 - FlashPROM.....5-13
 - RESET Modes5-13
 - Loading and Starting Panel Programs.....5-14
 - Update Mode/Reloading the Operating System5-15
- Accessories5-15

General Information

24 VDC Power Requirement

+24 VDC power must be supplied to the PANELWARE Controller unit. The Controller, in turn, supplies the Keyblock and Display modules with power.

When estimating the total +24 VDC power consumption for a system, add up the 24 VDC power supply requirements for all of the PANELWARE components being used, then add an additional 30% to allow for power-on surge currents. Appendix C lists power requirements for PANELWARE components.

Connecting Power to Controller

The 24 VDC power connector on the Controller is located on the top left corner of the unit. The mating connector is supplied with each Controller.

Caution

Do not try to run PANELWARE off a Series 90-30 power supply revision M or earlier. Although some configurations might function under this setup, it is not recommended. Damage to the 90-30 power supply could result.

The suitability of a Series 90-30 revision N or later power supply depends on the +24VDC isolated load requirements of the modules in your PLC. Refer to the *Series 90-30 Programmable Controller I/O Module Specifications* (GFK-0898) to determine additional load requirements of your system.

All components of a PLC and the devices it is controlling must be properly grounded. This is particularly important for the reasons listed below:

- A low-resistance path from all parts of a system to ground minimizes exposure to shock in the event of short circuits or equipment malfunction.
- PANELWARE Operator Panels require proper grounding for correct operation.

The importance of grounding can not be over emphasized.

Setting Number Switches

Number switch settings on the Panel Controller can be set using a small flathead screwdriver to turn the switch dial to the desired setting (the arrow will point at the current setting).

The assembled Panel configuration provides minimal space to reach the number switches once the Panel is installed. If possible, these settings should be made before the Controller is installed.

Basic Panel Controller (C200)

Specifications

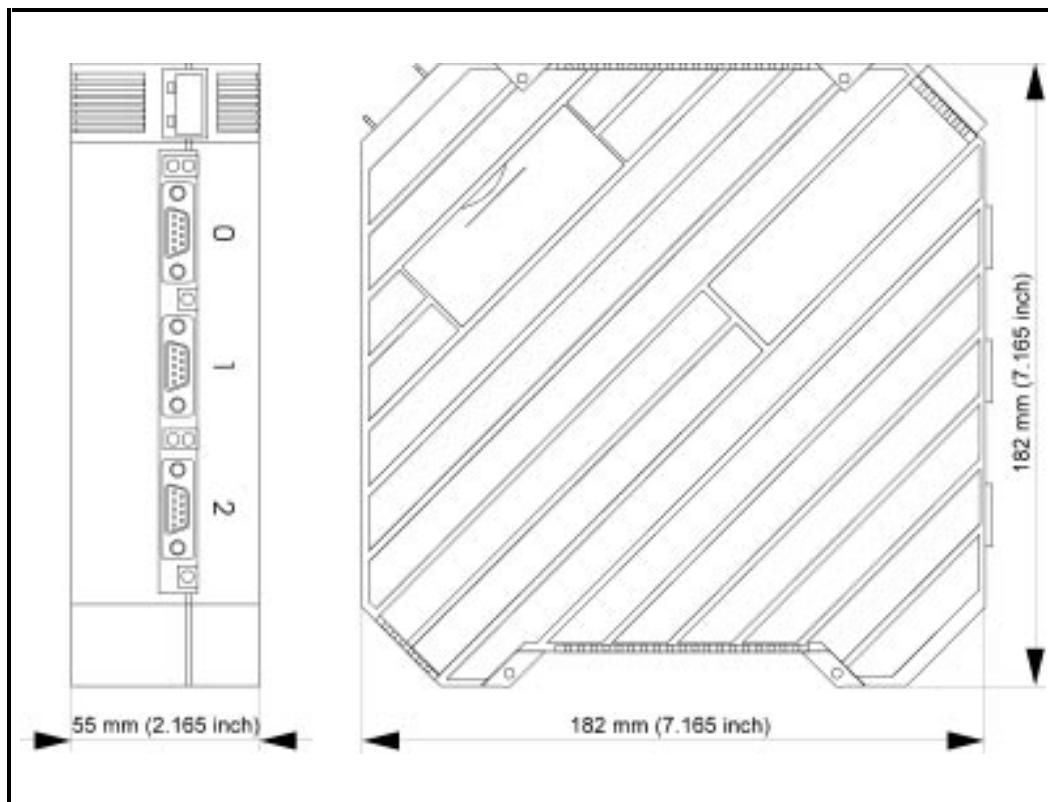

Figure 5 - 1. Basic Panel Controller (C200)

Table 5 - 1. Specifications for Basic Panel Controller (C200)

Catalog number	IC750CTR200
Interfaces	IF0: RS-232 (not galvanically isolated) IF1: RS-232 (not galvanically isolated) IF2: RS-422/RS-485 (galvanically isolated)
Programming	PANELWARE Configuration Software
Power supply	24 VDC (min. 18 VDC, max. 30 VDC)
Real-time clock	YES with battery installed (non-volatile)
Connection of ... Display modules Keyblock modules	1 maximum of 7
Temperature	
Operating	0 to 50 °C (32 to 122 °F)
Storage	-20 to 60 °C (-4 to 140 °F)
Relative humidity	
Operating	10 to 95 % (non-condensing)
Storage	10 to 95 % (non-condensing)

Table 5 - 1. - Continued

Shock	conforms to IEC 68-2-27 15g equivalent, 150 m/sec ² , 11 msec, 3 axes (positive and negative)
Vibration	conforms to IEC 68-2-6 1g equivalent, 10-58 Hz; 0.075 mm 58-150 Hz; 9.8m/sec ² 20 cycles per axis
Processor	Motorola 68302 @ 16 MHz
24 VDC power requirements	150 mA
Sealing	NEMA 12 and IP54 when mounted in a panel properly
Noise immunity	conforms to IEC 801.2; IEC 801.3; IEC 801.4

Overview of Connections and Operational Elements

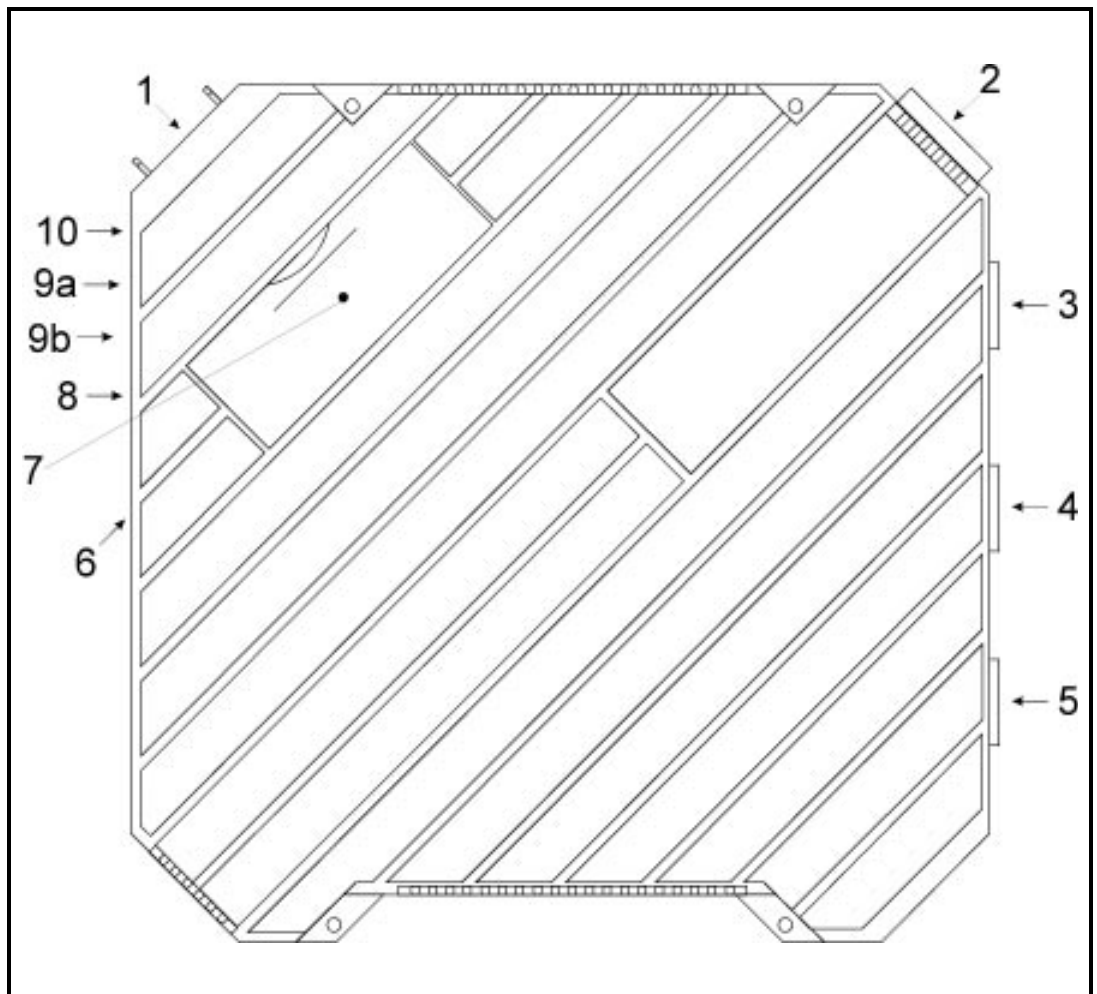
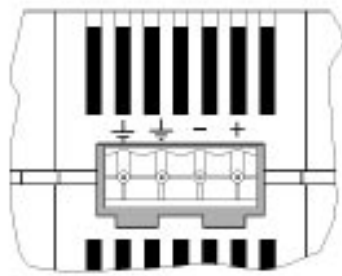

Figure 5 - 2. Basic Panel Controller (C200) Elements/Connections

1. Display Module Connector (ribbon cable)
2. 24 V Power Supply Connector
3. IF0: RS-232 (to PC), labeled 0
4. IF1: RS-232, labeled 1
5. IF2: RS-422/RS-485, labeled 2
6. Keypad Module Connector
7. Cover for Lithium Battery
8. Mode Switch - Operating Mode
9. (9a and 9b) Ventilation Holes
10. Reset Button

24 V Power Supply (item 2, figure 5-2)



Pin	Description
+	+24 V
-	0 V
⏏	Ground
⏏	Ground

The ⏏ pins are to be connected using as short a cable as is possible. If the Panel is mounted in a cabinet, the connecting cable should be as short as possible.

IF0 - RS-232, Non-isolated (item 3, figure 5-2)

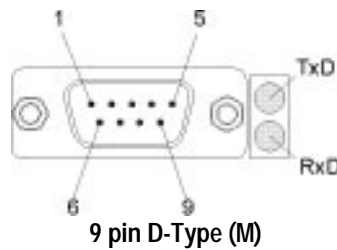

LED	Meaning
TxD	Send data over interface
RxD	Receive data over interface

Pin	Description	
1	NC	
2	RxD	Receive Data (Input)
3	TxD	Transmit Data (Output)
4	+ 5 V	Power Supply (200 mA available to user)
5	GND	Signal Ground
6	NC	
7	RTS	Request To Send (Input)
8	CTS	Clear To Send (Output)
9	NC	

IF1 - RS-232, Non-isolated (item 4, figure 5-2)

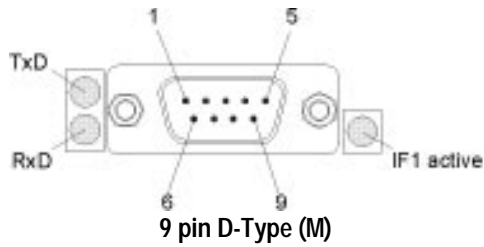

LED	Meaning
TxD	Send data over interface
RxD	Receive data over interface
IF1 active	Interface IF1 is active and IF2 is inactive.

Pin	Description	
1	NC	
2	RxD	Receive Data (Input)
3	TxD	Transmit Data (Output)
4	12 V	200 mA available to user
5	GND	Signal Ground
6	NC	
7	RTS	Request To Send (Input)
8	CTS	Clear To Send (Output)
9	NC	

IF2 - RS-422/RS-485, Isolated (item 5, figure 5-2)

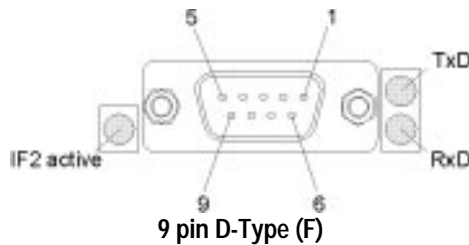

LED	Meaning
TxD	Send data over interface
RxD	Receive data over interface
IF2 active	Interface IF2 is active and IF1 is inactive.

Pin	Description	
	RS-422	RS-485
1	Shield	
2	SD (B)	NC
3	RD (B')	DATA
4	NC	NC
5	GND	
6	+5V _{DC} (200 mA available to user) galvanic isolation	
7	SD (A)	NC
8	RD (A')	$\overline{\text{DATA}}$
9	NC	NC

Interfaces IF1 and IF2 comprise only one interface. However, because of their triple assignment to different interface types, they are routed through one male and one female connector. This means that only one of the interfaces can be active at any given time. The active interface is indicated by an LED. Interface selection is made automatically by the software depending on the PLC protocol being used (i.e., SNP = IF2; L1 = IF1).

Lithium Battery (item 7, figure 5-2)

The lithium battery is stored in its own compartment in the Controller and covered for its own and the user's protection. It should be replaced every two years, or whenever the software indicates that the battery is low.

Instructions for replacing the battery are provided in chapter 2.

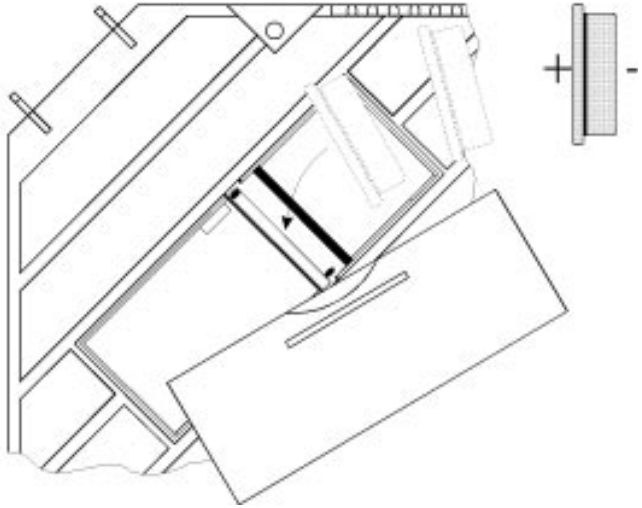

Warning

Lithium batteries are considered harmful waste. Please dispose of them in accordance with the instructions in the Material Safety Data Sheet (MSDS) that accompanied the battery, and in accordance with local regulations.

Mode Switch (item 8, figure 5-2)

The mode of operation for the Panel Controller is set using the Operating Mode switch (see table 5-2 for operating modes).

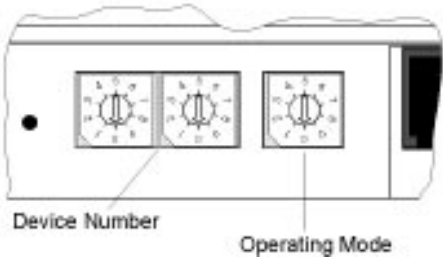

Reset Button (see 10, figure 5-2)

A hardware reset can be executed by pressing this button. Depending on the mode switch settings and the boot selection switch setting, different functions can be executed. These functions are explained in the descriptions of the connections and operational elements that follow.

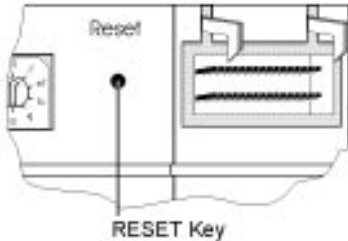

Genius Panel Controller (C400)

Specifications

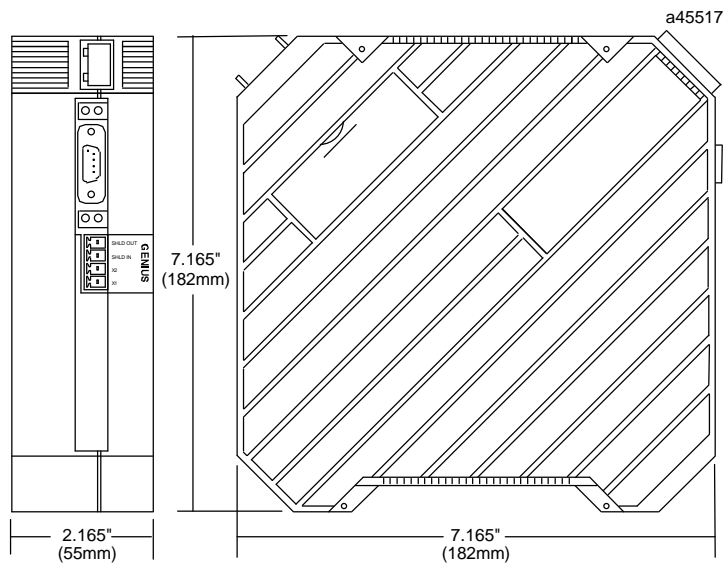

Figure 5 - 3. Genius Panel Controller (C400)

Table 5 - 2. Specifications for Genius Panel Controller (C400)

Catalog number	IC750CTR400
Interfaces	IF0: RS-232 (not galvanically isolated) GENIUS: (isolated)
Programming	PANELWARE Configuration Software
Power supply	24 VDC (min. 18 VDC, max. 30 VDC)
Real-time clock	YES with battery installed (non-volatile)
Connection of Display modules Keyblock modules	1 maximum of 7
Temperature	
Operating	0 to 50 °C (32 to 122 °F)
Storage	-20 to 60 °C (-4 to 140 °F)
Relative humidity	
Operating	10 to 95 % (non-condensing)
Storage	10 to 95 % (non-condensing)

Table 5 - 2. - Continued

Shock	conforms to IEC 68-2-27 15g equivalent, 150 m/sec ² , 11 msec, 3 axes (positive and negative)
Vibration	conforms to IEC 68-2-6 1g equivalent, 10-58 Hz; 0.075 mm 58-150 Hz; 9.8m/sec ² 20 cycles per axis
Processor	Motorola 68302 @ 16 MHz
24 VDC power requirements (typical)	185 mA, 24 VDC 260 mA, 18 VDC (minimum power voltage) 150 mA, 30 VDC (maximum power voltage)
Sealing	NEMA 12 and IP54 when properly mounted in a Panel
Noise immunity	conforms to IEC 801.2; IEC 801.3; IEC 801.4

Overview of Connections and Operational Elements

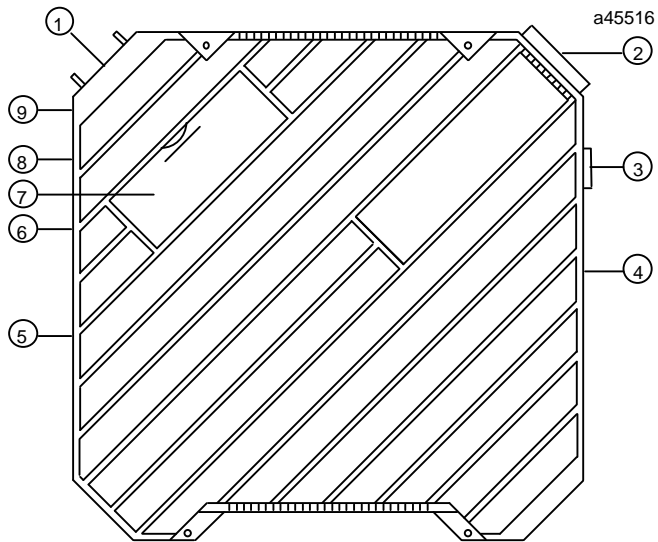
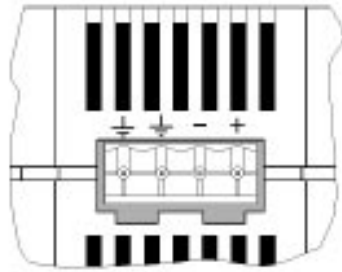

Figure 5 - 4. Genius Panel Controller (C400) Elements/Connections

- | | |
|--------------------------------------------|---------------------------------|
| 1. Display Module Connector (ribbon cable) | 6. Mode Switch - Operating Mode |
| 2. 24 VDC Power Supply Connector | 7. Cover for Lithium Battery |
| 3. IF0: RS-232 (to PC), labeled 0 | 8. Device Number Switches |
| 4. Genius Bus Connector | 9. Reset Button |
| 5. Keyblock Module Connector | |

24 VDC Power Supply (item 2, figure 5-5)



Pin	Description
+	+24 V
-	0 V
⏏	Ground
⏏	Ground

The ⏏ pins are to be connected using as short a cable as possible. If the Panel is mounted in a cabinet, the connecting cable should be as short as possible.

IF0 - RS-232, Non-isolated (item 3, figure 5-5)

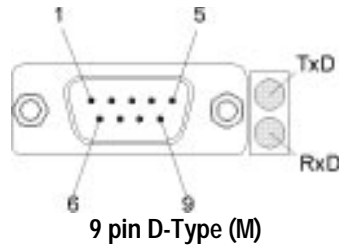

LED	Meaning
TxD	Send data over interface
RxD	Receive data over interface

Pin	Description	
1	NC	
2	RxD	Receive Data (Input)
3	TxD	Transmit Data (Output)
4	+ 5 V	Power Supply (200 mA available to user)
5	GND	Signal Ground
6	NC	
7	RTS	Request To Send (Input)
8	CTS	Clear To Send (Output)
9	NC	

Genius Bus Connector, Isolated (item 4, figure 5-5)

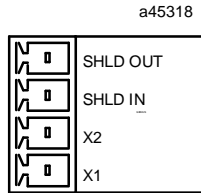

Pin	Description
SHLD OUT	Shield Out (to next physical device on bus)
SHLD IN	Shield In (from previous physical device on bus)
X2	Serial 2
X1	Serial 1

Mode Switch (item 6, figure 5-5)

The mode of operation for the Panel Controller is selected by setting the Operating Mode switch (see Table 2-2 for operating modes).

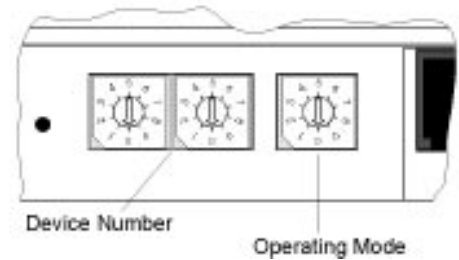

Device Number Switches (item 8, figure 5-5)

The Genius bus address for the C400 Controller is set using the Device Number switches. Valid device numbers are 00 to 31, inclusive.

Lithium Battery (item 7, figure 5-5)

The lithium battery is stored in its own compartment in the Controller and covered for its own and the user's protection. It should be replaced every two years, or whenever the software indicates that the battery is low.

Instructions for replacing the battery are provided in chapter 2.

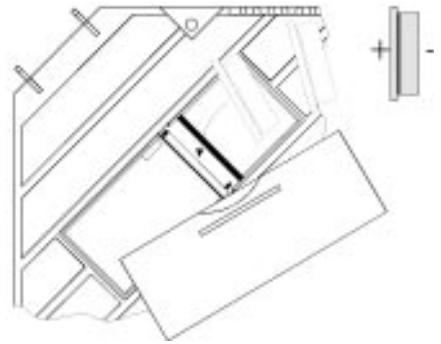

Warning

Lithium batteries are considered harmful waste. Dispose of them in accordance with the instructions in the Material Safety Data Sheet (MSDS) that accompany the battery, and in accordance with local regulations.

Reset Button (item 9, figure 5-3)

A hardware reset can be executed by pressing this button. Depending on the setting of the mode selection switch, different functions can be executed. These functions are explained in the descriptions of the connections and operational elements that follow.

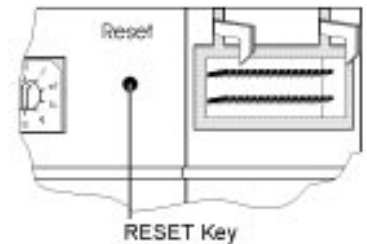

Operating the Controllers

Unless indicated otherwise, the information in this section applies to both types of Controller (C200 and C400).

FlashPROM

The Panel Controller has non-volatile memory called FlashPROM, which is split into two separate areas (banks):

The **System Bank** contains the operating system, which is necessary for the Panel program to be processed. You **can not** delete the system bank. *Routine operating system updates* to a higher revision level are performed with PCS in *Update-Mode*.

The **User Bank** contains the Panel program that controls and is used by the Display and Keyblock modules. The Panel program is created using PCS on a standard PC and sent in *Teach-Mode*.

RESET Modes

The operating mode that is entered after a Reset or power-on, depends on the setting of the mode switch (operating mode). The mode switch is used to select *run*, *update*, or *teach* mode. In addition, for the Genius (C400) Controller, settings 1 — 5 select the baudrate in *run* mode. The following tables list the operating modes:

Table 5 - 3. C200 Controller Mode Switch Settings (See item 4, figure 5-2)

Switch Setting	Description
1 - 4	Reserved for future applications
5	<i>RUN Mode:</i> The Panel Controller starts the operating system from the FlashPROM (Bank 0). Existing Panel programs (in FlashPROM User Bank) are started automatically.
6	<i>Update Mode:</i> An update of the operating system can be performed using PCS.
7	<i>Teach Mode:</i> Panel programs that are created by means of PCS are transferred to the FlashPROM (User Bank).
8 - 9	Not allowed

Table 5 - 4. C400 Controller Mode Switch Settings (See item 6, figure 5-3)

Switch Setting	Description
1*	<i>Run Mode</i> , 153.6 kBaud extended
2*	<i>Run Mode</i> , 76.8 kBaud
3*	<i>Run Mode</i> , 38.4 kBaud
4*	<i>Run Mode</i> , 153.6 kBaud standard
5*	<i>Run Mode</i> , 153.6 kBaud standard, or the baudrate set in PCS
6	<i>Update Mode</i> : An update of the operating system can be performed with PCS.
7	<i>Teach Mode</i> : Panel programs that are created by means of PCS are transferred to the FlashPROM (User Bank)
8-9	<i>Not allowed</i>

* Run Mode: The Panel Controller starts the operating system from the FlashPROM (Bank 0). Existing Panel programs (in FlashPROM User Bank) are started automatically.

Loading and Starting Panel Programs

A Panel program is created using PCS and then transferred (loaded) to the Panel through the serial interface when *Teach Mode* is selected. To start an application, *RUN Mode* must be selected. The following sections outline how to load, start, and reload the operating system.

Loading the Panel Program

Note

If you are using a printer with either the C200 or C400 Controller, the printer must be disconnected while the Panel program is loaded.

1. Connect the PC (COM1 or COM2) to the Panel Controller (always IF0) using the appropriate serial cable (see appendix A).
2. Select Teach Mode (position 7).
3. Press the Reset button.
4. Wait until *Teach-Mode* is displayed.
5. Start the transfer from PCS.
6. Wait until PCS acknowledges that the entire Panel program has been transferred.

Starting the Panel Program

1. Select *Run Mode* (position 5). (If you are using a C400 Controller select position 1 — 5, as appropriate.)
2. Connect the PLC to the Panel Controller (see the *Application Manual* that pertains to the PLC protocol you are using).
3. Press the Reset button.

Update Mode/Reloading the Operating System

The Panel Controller's operating system can be reloaded from PCS. The steps for accomplishing this transfer are identical to those in "Loading the Panel Program," except that *Update Mode* (position 6) is selected.

Note

The *Update Mode* is required only to support a future operating system upgrade.

To update in this mode, proceed as follows:

1. Select *Update Mode* (position 6).
2. Press the Reset button.
3. In PCS, begin the update operation.
4. Wait until PCS acknowledges that the update is complete.
5. Select *Run Mode* (position 5). (If you are using a C400 Controller select position 1 — 5, as appropriate.)
6. Press the Reset button to start the existing Panel program.

Accessories

Accessory components are required for connecting and installing each Panel Controller. These accessories are shipped in the same package as the Panel Controller in the quantities indicated below.

Table 5 - 5. Panel Controller Accessory Components

Accessories	Quantity
Termination resistor (connected in the output of the last Keyblock module)	1
Sealant for creating a seal between the panel and the cutout or bezel	1 tube with nozzle and squeezing tool
Lithium battery	1, plus MSDS sheet
Label sheets (1 @ A4 size; 1 @ 8.5 X 11) for Keyblock modules with 4 keys, 8 keys, and 16 keys (12+4)	1 set
Power connector	1
Long keyboard cable	1
Screws (#1 Phillips) for connecting Panel Controller to Display or Keyblock modules	4

Chapter 6

Accessories

This chapter describes and illustrates the accessories that are included in the accessories set for use as replacement parts, and those that can be purchased individually. It includes the following information:

- Accessories Set (Spare Parts)6-2
- Lithium Battery6-3
- Label Sheets6-4
- Mounting Bezels.....6-5
- Serial Cables and Adapter6-5
- Lamps for Special Keyblock Modules6-5

Accessories Set (Spare Parts)

The standard accessories set contains replacement parts for every type of module. The following illustration and table show the contents of an accessories set.

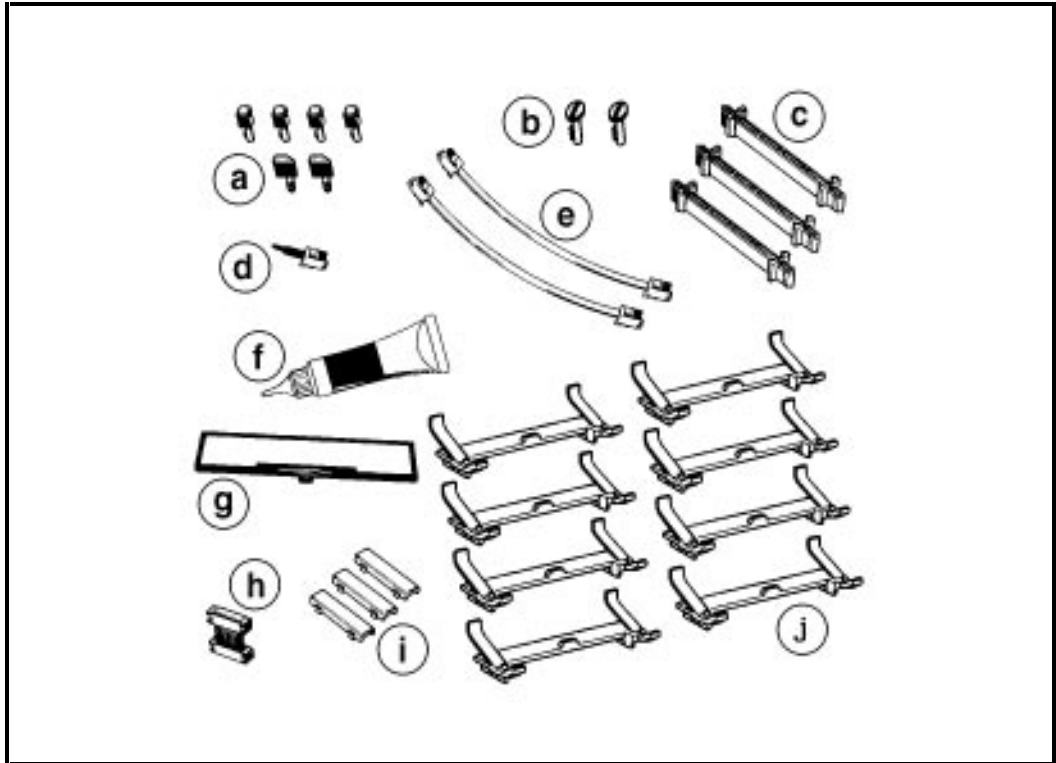

Figure 6 - 1. Accessories Set

Table 6 - 1. Contents of Accessories Set

Item	Catalog Number
1 Accessory Set Contents: a 1 set of mounting pins b 2 mounting pins c 3 module connectors d 1 termination resistor e 2 Keyblock cables f 1 tube of sealant with application nozzle and squeezing tool g 1 battery compartment cover h 1 ribbon cable i 3 cable covers j 8 spring clips k 4 Controller screws l 1 power connector 1 PANELWARE assembly and installation sheet	IC750ACC004

Lithium Battery

The lithium battery for the Controller can be ordered separately as a replacement part or purchased locally using the ordering information below.

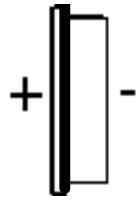

Figure 6 - 2. Lithium Battery (RENATA CR2477N)

Warning

Used lithium batteries are considered hazardous waste and should be disposed of in accordance with the MSDS guidelines that accompany each battery, and in accordance with local regulations.

Caution

Pick up the battery using your fingers only; do not touch any conductive material to the battery (e.g., pliers).

Table 6 - 2. Lithium Battery Ordering Information

Item	Catalog Number
1 lithium battery	IC750ACC002 (Renata # CR2477N type battery)
For details on installing or changing the lithium battery, see Chapter 2, "Assembling System Components."	

Label Sheets

Packages of label sheets for each Keyblock module can be ordered separately for creating new applications. Sheets are delivered in two sizes—A4 and US letter (8.5" X 11").

Each label sheet consists of six perforated legend layouts that allow an LED to show through on the Keyblock. To remove an individual label from the sheet, simply locate one of the six perforated squares and tear gently along the perforated lines. Gently insert the label behind the plastic Keyblock cover as outlined in Chapter 2, “Assembling System Components.”



Figure 6 - 3. Label Sheets

Table 6 - 3. Label Sheets for Keyblock Modules — Ordering Information

Item	Catalog Number
1 set of label sheets Contents: 5 label sheets for 4-key modules (A4 size) 5 label sheets for 8-key modules (A4 size) 5 label sheets for 16 or 12+4 key-modules (A4 size) 5 label sheets for 4-key modules (US letter size) 5 label sheets for 8-key modules (US letter size) 5 label sheets for 16 or 12+4-key modules (US letter size)	IC750ACC005

Mounting Bezels

For easier Panel installation, two different mounting bezel configurations can be ordered separately — one for a 2 X 3 unit (2 high by 3 wide), and one for a 2 X 2 unit (2 high by 2 wide). Mounting bolts are welded to the bezels, with mounting captive locking washers and nuts provided. An assembled PANELWARE unit is mounted and sealed inside the bezel, which is then mounted and sealed into the cutout.

The cutout and mounting holes for the bezels must match the dimensions provided in the “Installation Options” section of chapter 2.

Table 6 - 4. Mounting Bezel Ordering Information

Item	Catalog Number
1 mounting bezel for a 2 X 2 unit	IC750ACC220
1 mounting bezel for a 2 X 3 unit	IC750ACC230
Mounting bezels include the necessary mounting hardware to install the unit into the cutout.	

Serial Cables and Adapter

Two cables can be ordered separately, an RS-232 cable and an RS-422 cable. A 25-pin-to-9-pin adapter accompanies the RS-232 cable.

Table 6 - 5. Serial Cables Ordering Information

Function	Item	Catalog Number
Connects Panel to Series 90	1 RS-422 serial cable	IC750CBL001
Connects PC to Panel	1 RS-232 serial cable, with 25-pin to 9-pin adapter	IC750CBL002
See chapter 8 and appendix A for details on connecting the serial cables.		

Lamps for Special Keyblock Modules

Lamps in the Keyswitch, Start/Stop, and Emergency Stop Keyblock modules may need to be replaced. Ordering information for replacement lamps is provided in table 6-7.

Table 6 - 6. Ordering Information for Replacement Lamps

Type	Catalog Number
24 — 30VAC, 2W, BA9S	RAFI 1.90060.133
110 — 130VAC, 2W, BA9S	RAFI 1.90060.137

Chapter 7

Printers

This chapter describes and illustrates the connections from the printer to the C200 and C400 Panel Controllers as follows:

- Printer to Panel Controller.....7-2
 - Printer to C2007-2
 - Printer to C4007-2
 - Interface Selection7-2
- Cabling Schematic.....7-3

Printer to Panel Controller

A printer can be connected to the IF0 serial interface of the Panel Controller as illustrated below. The printer must be run through an RS-232 serial interface.

Printer to C200

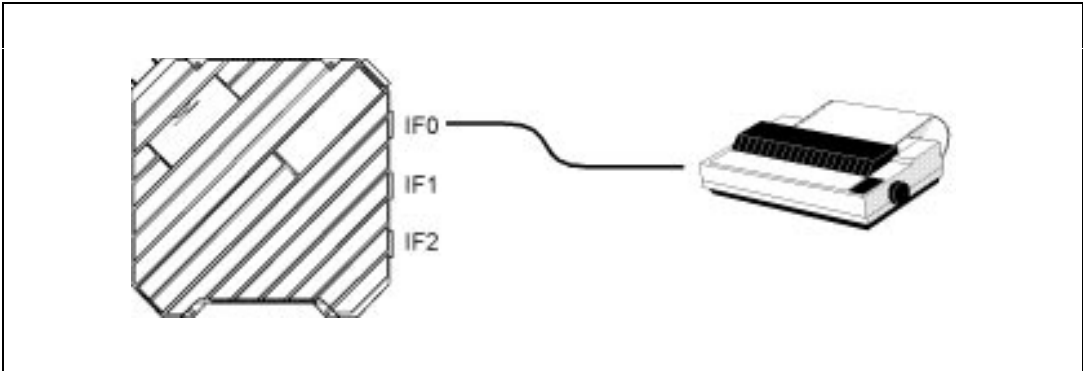

Figure 7 - 1. Printer Connections to C200

Printer to C400

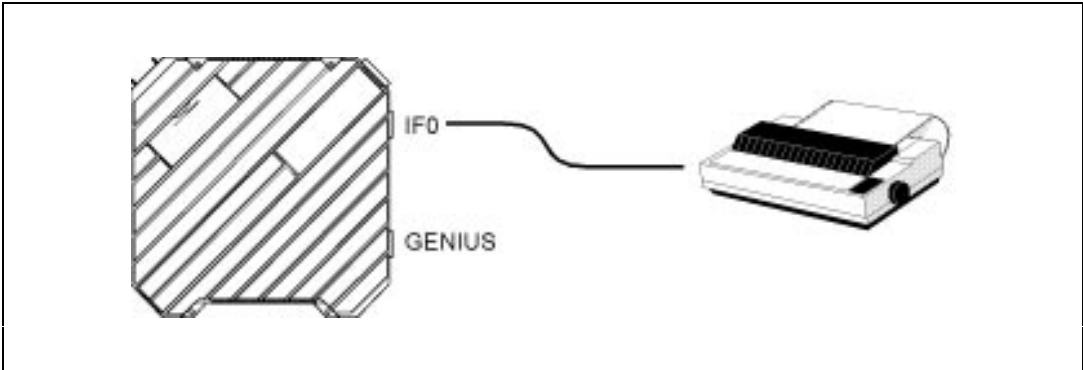

Figure 7 - 2. Printer Connections to C400

Interface Selection

The desired serial interface (IF0) and the baud rate that should be used by the Panel Controller must be selected via the Panelware Configuration Software.

Cabling Schematic

The serial printer cable can be connected to the IF0 serial interface on the Panel Controller as illustrated below:

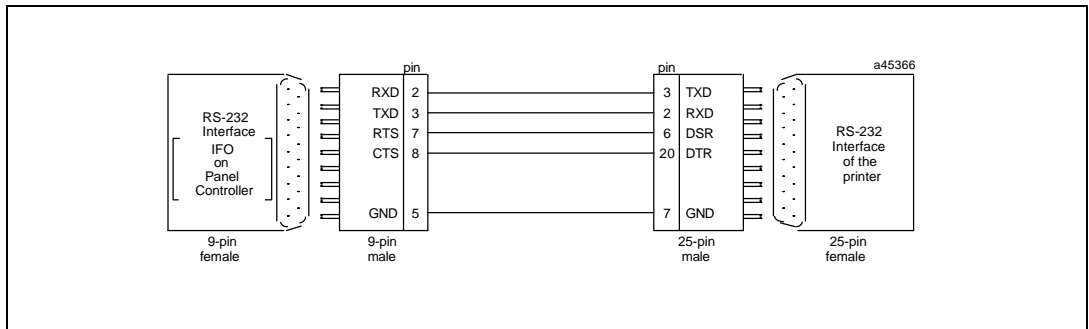

Figure 7 - 3. Serial Printer Cable Connections

Chapter 8

Troubleshooting/Error Diagnosis

This chapter provides guidelines for finding and diagnosing unit errors relating to the hardware installation. (Refer to the *PANELWARE Configuration Software Reference Manual* — GFK-0849 and to the appropriate *Application Manual* for the protocol you are using for troubleshooting/diagnosis information relating to software operation.) This chapter includes the following information:

- General Information8-2
 - Visual Check8-2
 - Powering On for the First Time8-2
 - Starting an Application.....8-2
- Error Messages on Panel Displays with C200 or C400 Controllers8-3
- Other Errors8-4

General Information

Before a completed Panel is installed into a cabinet, a rack or a machine, it must be fully tested as outlined below.

Visual Check

Before connecting power to and powering up the unit, the following visual checks should be performed:

- Are mechanical attachments making a good connection?
- Is the ribbon cable correctly connected between the display module and the Panel Controller?
- Are Keyblock connections made properly?

Caution

The cables between Keyblock modules must be connected from the output of one to the input of another, otherwise module failure may result.

- Are all cables that will come in contact with the bezel located inside the Panel lip?
- Is the termination resistor attached to the last Keyblock module?
- If necessary, check number switch settings.

Powering On for the First Time

With 24 V power connected to the Panel, the LEDs will be illuminated and run a test pattern, then a message should appear on the display.

See the following sections for information on error messages.

Starting an Application

In order to test a Panel completely, an entire application can be started before the installation is finished, thereby ensuring the modular unit is functional.

Error Messages on Panel Displays with C200 or C400 Controllers

Caution

The cables between Keyblock modules must be connected from the output of one to the input of another, otherwise module failure may result.

To test a PANELWARE Panel, the 24 V supply is connected to the designated connector. After a brief delay, a status message appears on the display. This status message may be overwritten immediately by the following messages or by the Panel program:

Keyboard Error Code 7511

- The daisy chain connecting the keyboard units in your system is incomplete. Check the following items:

Caution

Remove power from the system before disconnecting and connecting cables.

- Make sure all Keyblock cables are securely installed and fully seated. (A simple click does not mean secure installation.)
- Verify that the Keyblock cable termination plug is installed (it is shipped in the Controller box).
- Use the process of elimination to detect a failed keyboard module: Move the termination to the first Keyblock in the daisy chain and check for the error code. If the first Keyblock is OK, add one Keyblock at a time, checking for the error code each time, to determine if one of them (or its connecting cable) is defective.

The cables between Keyblock modules must be connected from the output of one to the input of another, otherwise module failure may result.

No program

A Panel tries to start a user-created Panel program after a power-on (or Reset). If no Panel program exists, the **No program** message appears on the screen.

- Transfer a Panel program from a PC (using PCS). See the *PANELWARE Configuration Software Reference Manual* (GFK-0849), and the appropriate *Application Manual* for the protocol you are using, for details.

Other Errors

The following problems may occur with no error message displayed. If one of these problems is encountered, take the appropriate action outlined below.

Display is dark

- Is the ribbon cable connected correctly between the display module and the Panel Controller?
- Is the power switched on?
- In order to locate the error, exchange the display module with one that is functioning:
 - If the replacement display is also dark, check the Panel Controller and its operating system.
 - If the status message is seen on the replacement display, the initial display is defective.

Display is illuminated, but no text is seen

- Is the ribbon cable connected correctly between the display module and the Panel Controller?

LEDs do not light on the Keyblock module

After a power-on (or a Reset) the LEDs on the Keyblock modules must illuminate briefly and run a test pattern. If this does not occur, check the following:

- Is the termination resistor attached to the last Keyblock module?
- Are Keyblock connections made properly?

Caution

The cables between Keyblock modules must be connected from the output of one to the input of another, otherwise module failure may result.

- Test individual Keyblock modules with only one module connected to the Controller at a time (with termination resistor connected) in order to locate the defective module.

Cannot make connection with PC

The Panel must be connected through interface IF0 to the PC on which PCS is installed. If no Panel program can be transferred to or from the Panel, check the following:

- Is the operating mode set correctly on the Panel Controller (*Teach Mode*)?
- Is the proper serial cable connected, connected properly and in good shape?
- Is the serial cable connected to interface IF0 of the Panel Controller?
- Is the proper PC interface defined for communication in PCS?

This appendix explains and illustrates the connection cabling between the C200 Panel Controller and the PC as follows:

- Panel Controllers to PC ConnectionsA-2
- Cabling Schematic.....A-3

Note

For Panel Controller-to-PLC cabling information, refer to the appropriate *Application Manual* for the protocol that you are using.

Panel Controller to PC Connections

The Basic Panel Controller (C200) or Genius Panel Controller (C400) is connected to the PC via a serial interface. The Panel Controller's IF0 interface is connected to the RS-232 or the RS-422 interface of the PC (COM1 or COM2) using a serial cable as illustrated in figures A-1 and A-2.

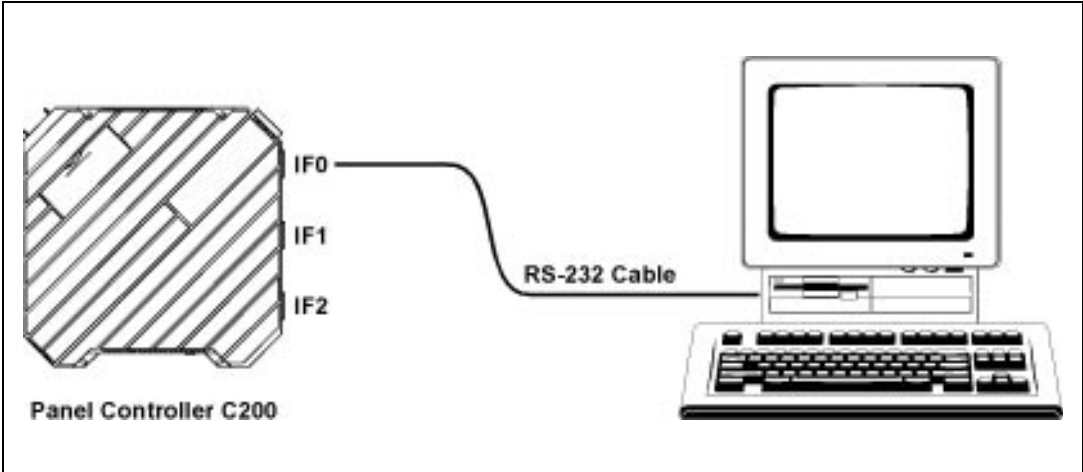

Figure A - 1. C200 Controller Connection to PC

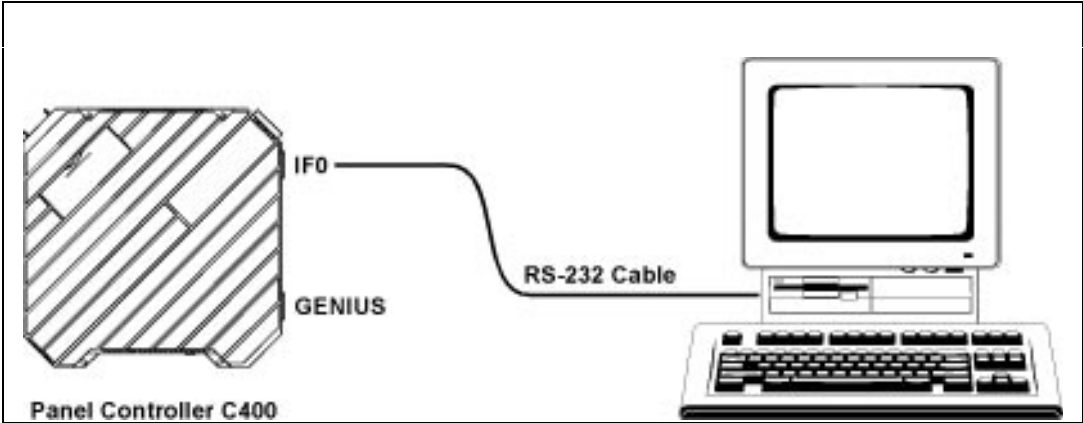

Figure A - 2. C400 Controller Connection to PC

Cabling Schematic

The serial cable that connects the Panel Controller to the PC can be ordered separately using catalog number IC750CBL002 (see chapter 6 for ordering details).

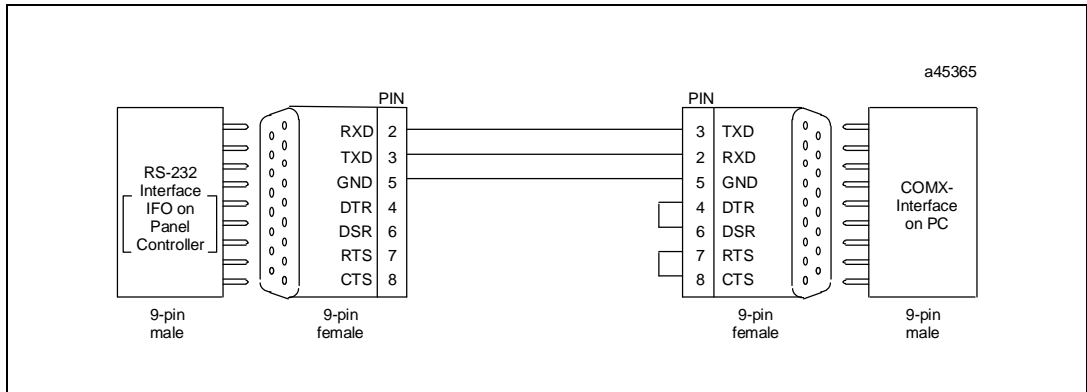

Figure A - 3. Serial Connection Between Controller and PC

If the PC has a 25-pin connector instead of a 9-pin D-Type male serial interface, an adapter is necessary. This adapter is provided when you order the RS-232 cable.

Appendix

B

Character Sets

This appendix lists the following character sets that are available for use on the PANELWARE display modules:

- Character Set for VFD and Graphics-Capable LCD Displays B-2
- Character Set for Character-Oriented LCD Displays B-6

Character Set for VFD and Graphics-Capable LCD Displays

Dec.	Hex.	Character	Control Character	Dec.	Hex.	Character	Control Character
000	\$00			032	\$20		SPC
001	\$01			033	\$21	!	
002	\$02			034	\$22	"	
003	\$03			035	\$23	#	
004	\$04			036	\$24	\$	
005	\$05			037	\$25	%	
006	\$06			038	\$26	&	
007	\$07			039	\$27	'	
008	\$08		BS	040	\$28	(
009	\$09			041	\$29)	
010	\$0A		LF	042	\$2A	*	
011	\$0B			043	\$2B	+	
012	\$0C			044	\$2C	,	
013	\$0D			045	\$2D	-	
014	\$0E			046	\$2E	.	
015	\$0F			047	\$2F	/	
016	\$10			048	\$30	0	
017	\$11		XON	049	\$31	1	
018	\$12		DC2	050	\$32	2	
019	\$13		XOFF	051	\$33	3	
020	\$14		DC4	052	\$34	4	
021	\$15			053	\$35	5	
022	\$16		SYN	054	\$36	6	
023	\$17			055	\$37	7	
024	\$18			056	\$38	8	
025	\$19			057	\$39	9	
026	\$1A			058	\$3A	:	
027	\$1B		ESC	059	\$3B	;	
028	\$1C			060	\$3C	<	
029	\$1D			061	\$3D	=	
030	\$1E			062	\$3E	>	
031	\$1F			063	\$3F	?	

Dec.	Hex.	Character	Control Character	Dec.	Hex.	Character	Control Character
064	\$40	@		096	\$60	`	
065	\$41	A		097	\$61	a	
066	\$42	B		098	\$62	b	
067	\$43	C		099	\$63	c	
068	\$44	D		100	\$64	d	
069	\$45	E		101	\$65	e	
070	\$46	F		102	\$66	f	
071	\$47	G		103	\$67	g	
072	\$48	H		104	\$68	h	
073	\$49	I		105	\$69	i	
074	\$4A	J		106	\$6A	j	
075	\$4B	K		107	\$6B	k	
076	\$4C	L		108	\$6C	l	
077	\$4D	M		109	\$6D	m	
078	\$4E	N		110	\$6E	n	
079	\$4F	O		111	\$6F	o	
080	\$50	P		112	\$70	p	
081	\$51	Q		113	\$71	q	
082	\$52	R		114	\$72	r	
083	\$53	S		115	\$73	s	
084	\$54	T		116	\$74	t	
085	\$55	U		117	\$75	u	
086	\$56	V		118	\$76	v	
087	\$57	W		119	\$77	w	
088	\$58	X		120	\$78	x	
089	\$59	Y		121	\$79	y	
090	\$5A	Z		122	\$7A	z	
091	\$5B	[123	\$7B	{	
092	\$5C	\		124	\$7C	 	
093	\$5D]		125	\$7D	}	
094	\$5E	^		126	\$7E	~	
095	\$5F	_		127	\$7F		DEL

Dec.	Hex.	Character	Control Character	Dec.	Hex.	Character	Control Character
128	\$80	Ç		160	\$A0	á	
129	\$81	ü		161	\$A1	í	
130	\$82	é		162	\$A2	ó	
131	\$83	â		163	\$A3	ú	
132	\$84	ä		164	\$A4	ñ	
133	\$85	à		165	\$A5	Ñ	
134	\$86	å		166	\$A6	ª	
135	\$87	ç		167	\$A7	º	
136	\$88	ê		168	\$A8	¿	
137	\$89	ë		169	\$A9	⌈	
138	\$8A	è		170	\$AA	⌋	
139	\$8B	ï		171	\$AB	½	
140	\$8C	î		172	\$AC	¼	
141	\$8D	ì		173	\$AD	¡	
142	\$8E	Ä		174	\$AE	«	
143	\$8F	Å		175	\$AF	»	
144	\$90	É		176	\$B0	α	
145	\$91	æ		177	\$B1	Ⓜ	
146	\$92	Æ		178	\$B2	γ	
147	\$93	ô		179	\$B3	Δ	
148	\$94	ö		180	\$B4	ε	
149	\$95	ò		181	\$B5	η	
150	\$96	û		182	\$B6	θ	
151	\$97	ù		183	\$B7	λ	
152	\$98	ÿ		184	\$B8	μ	
153	\$99	Ö		185	\$B9	π	
154	\$9A	Ü		186	\$BA	ρ	
155	\$9B		CSI	187	\$BB	σ	
156	\$9C	£		188	\$BC	τ	
157	\$9D	¥		189	\$BD	φ	
158	\$9E	₣		190	\$BE	Ω	
159	\$9F	f		191	\$BF	Σ	

Dec.	Hex.	Character	Control Character	Dec.	Hex.	Character	Control Character
192	\$C0	§		224	\$E0	Й	
193	\$C1	Е		225	\$E1	Ђ	
194	\$C2	Р		226	\$E2	П	
195	\$C3	Ј		227	\$E3	У	
196	\$C4	Ћ		228	\$E4	Ф	
197	\$C5	1		229	\$E5	Ц	
198	\$C6	2		230	\$E6	Ч	
199	\$C7	3		231	\$E7	Ш	
200	\$C8	х		232	\$E8	Щ	
201	\$C9	√		233	\$E9	Ъ	
202	\$CA	±		234	\$EA	Ы	
203	\$CB	¢		235	\$EB	Э	
204	\$CC		FREE	236	\$EC	Ю	
205	\$CD		FREE	237	\$ED	Я	
206	\$CE		FREE	238	\$EE		FREE
207	\$CF		FREE	239	\$EF	□	
208	\$D0	А		240	\$F0	≤	
209	\$D1	É		241	\$F1	≥	
210	\$D2	Ù		242	\$F2	≠	
211	\$D3	È		243	\$F3	⊥	
212	\$D4	Ì		244	\$F4	∞	
213	\$D5	Â		245	\$F5	~	
214	\$D6	Ê		246	\$F6	≡	
215	\$D7	Î		247	\$F7	⊕	
216	\$D8	Ô		248	\$F8	⊖	
217	\$D9	Ù		249	\$F9	←	
218	\$DA	Ь		250	\$FA	→	
219	\$DB	Г		251	\$FB	↩	
220	\$DC	Д		252	\$FC	→	
221	\$DD	Ж		253	\$FD		
222	\$DE	З		254	\$FE		FREE
223	\$DF	И		255	\$FF		FREE

Character Set for Character-Oriented LCD Displays

Dec.	Hex.	Character	Control Character	Dec.	Hex.	Character	Control Character
000	\$00			032	\$20		SPC
001	\$01			033	\$21	!	
002	\$02			034	\$22	"	
003	\$03			035	\$23	#	
004	\$04			036	\$24	\$	
005	\$05			037	\$25	%	
006	\$06			038	\$26	&	
007	\$07			039	\$27	'	
008	\$08		BS	040	\$28	(
009	\$09			041	\$29)	
010	\$0A		LF	042	\$2A	*	
011	\$0B			043	\$2B	+	
012	\$0C			044	\$2C	,	
013	\$0D			045	\$2D	-	
014	\$0E			046	\$2E	.	
015	\$0F			047	\$2F	/	
016	\$10			048	\$30	0	
017	\$11		XON	049	\$31	1	
018	\$12		DC2	050	\$32	2	
019	\$13		XOFF	051	\$33	3	
020	\$14		DC4	052	\$34	4	
021	\$15			053	\$35	5	
022	\$16		SYN	054	\$36	6	
023	\$17			055	\$37	7	
024	\$18			056	\$38	8	
025	\$19			057	\$39	9	
026	\$1A			058	\$3A	:	
027	\$1B		ESC	059	\$3B	;	
028	\$1C			060	\$3C	<	

Dec.	Hex.	Character	Control Character	Dec.	Hex.	Character	Control Character
029	\$1D			061	\$3D	=	
030	\$1E			062	\$3E	>	
031	\$1F			063	\$3F	?	
064	\$40	@		096	\$60	`	
065	\$41	A		097	\$61	a	
066	\$42	B		098	\$62	b	
067	\$43	C		099	\$63	c	
068	\$44	D		100	\$64	d	
069	\$45	E		101	\$65	e	
070	\$46	F		102	\$66	f	
071	\$47	G		103	\$67	g	
072	\$48	H		104	\$68	h	
073	\$49	I		105	\$69	i	
074	\$4A	J		106	\$6A	j	
075	\$4B	K		107	\$6B	k	
076	\$4C	L		108	\$6C	l	
077	\$4D	M		109	\$6D	m	
078	\$4E	N		110	\$6E	n	
079	\$4F	O		111	\$6F	o	
080	\$50	P		112	\$70	p	
081	\$51	Q		113	\$71	q	
082	\$52	R		114	\$72	r	
083	\$53	S		115	\$73	s	
084	\$54	T		116	\$74	t	
085	\$55	U		117	\$75	u	
086	\$56	V		118	\$76	v	
087	\$57	W		119	\$77	w	
088	\$58	X		120	\$78	x	
089	\$59	Y		121	\$79	y	
090	\$5A	Z		122	\$7A	z	
091	\$5B	[123	\$7B	{	

B

Dec.	Hex.	Character	Control Character	Dec.	Hex.	Character	Control Character
092	\$5C	¥		124	\$7C		
093	\$5D]		125	\$7D	}	
094	\$5E	^		126	\$7E	→	
095	\$5F	_		127	\$7F	←	
128	\$80		FREE	160	\$A0		FREE
129	\$81	ü		161	\$A1	▣	
130	\$82		FREE	162	\$A2	┌	
131	\$83		FREE	163	\$A3	└	
132	\$84	ä		164	\$A4	、	
133	\$85		FREE	165	\$A5	・	
134	\$86		FREE	166	\$A6	マ	
135	\$87		FREE	167	\$A7	ア	
136	\$88		FREE	168	\$A8	イ	
137	\$89		FREE	169	\$A9	ウ	
138	\$8A		FREE	170	\$AA	エ	
139	\$8B		FREE	171	\$AB	オ	
140	\$8C		FREE	172	\$AC	カ	
141	\$8D		FREE	173	\$AD	キ	
142	\$8E	Ä		174	\$AE	ヨ	
143	\$8F		FREE	175	\$AF	ツ	
144	\$90		FREE	176	\$B0	ー	
145	\$91		FREE	177	\$B1	ア	
146	\$92		FREE	178	\$B2	イ	
147	\$93		FREE	179	\$B3	ウ	
148	\$94	ö		180	\$B4	エ	
149	\$95		FREE	181	\$B5	オ	
150	\$96		FREE	182	\$B6	カ	
151	\$97		FREE	183	\$B7	キ	
152	\$98		FREE	184	\$B8	ク	
153	\$99	Ö		185	\$B9	ケ	
154	\$9A	Ü		186	\$BA	コ	
155	\$9B		CSI	187	\$BB	サ	
156	\$9C		FREE	188	\$BC	シ	
157	\$9D		FREE	189	\$BD	ス	

Dec.	Hex.	Character	Control Character	Dec.	Hex.	Character	Control Character
158	\$9E		FREE	190	\$BE	㇗	
159	\$9F		FREE	191	\$BF	㇘	
192	\$C0	㇑		224	\$E0		FREE
193	\$C1	㇒		225	\$E1		FREE
194	\$C2	㇓		226	\$E2		FREE
195	\$C3	㇔		227	\$E3		FREE
196	\$C4	㇕		228	\$E4		FREE
197	\$C5	㇖		229	\$E5		FREE
198	\$C6	㇗		230	\$E6		FREE
199	\$C7	㇘		231	\$E7		FREE
200	\$C8	㇙		232	\$E8		FREE
201	\$C9	㇚		233	\$E9		FREE
202	\$CA	㇛		234	\$EA		FREE
203	\$CB	㇜		235	\$EB		FREE
204	\$CC	㇝		236	\$EC		FREE
205	\$CD	㇞		237	\$ED		FREE
206	\$CE	㇟		238	\$EE		FREE
207	\$CF	㇠		239	\$EF		FREE
208	\$D0	㇡		240	\$F0		FREE
209	\$D1	㇢		241	\$F1		FREE
210	\$D2	㇣		242	\$F2		FREE
211	\$D3	㇤		243	\$F3		FREE
212	\$D4	㇥		244	\$F4		FREE
213	\$D5	㇦		245	\$F5		FREE
214	\$D6	㇧		246	\$F6		FREE
215	\$D7	㇨		247	\$F7		FREE
216	\$D8	㇩		248	\$F8		FREE
217	\$D9	㇪		249	\$F9		FREE
218	\$DA	㇫		250	\$FA		FREE
219	\$DB	㇬		251	\$FB		FREE
220	\$DC	㇭		252	\$FC		FREE
221	\$DD	㇮		253	\$FD		FREE
222	\$DE	㇯		254	\$FE		FREE
223	\$DF	ㇰ		255	\$FF		FREE

Power Consumption

The PANELWARE Controller unit requires +24 VDC power. The Controller, in turn, supplies the Keyblock and display modules with power. Table C-1 summarizes +24 VDC power requirements for PANELWARE modules.

Note

When estimating the total 24 VDC power consumption for a system, add up the rated power requirements for all PANELWARE components being used, then add an additional 30% to allow for power-on surge currents.

Table C - 1. Power Requirements

Module	Catalog Number	+24 VDC Power Consumption	
		(mA)	(Watts)
Display Module 2 x 20 LCD	IC750LCD220	100	2.4
Display Module 4 x 20 LCD	IC750LCD420	200	4.8
Display Module 4 x 40 LCD	IC750LCD440	250	6.0
Display Module 8 x 40 LCD	IC750LCD840	200	4.8
Display Module 8 x 40 CFL	IC750CFL840	200	4.8
Display Module 2 x 20 VFD	IC750VFD220	200	4.8
Display Module 2 x 40 VFD	IC750VFD240	200	4.8
Keyblock Module - 16 keys	IC750KBL160	50	1.2
Keyblock Module - Numeric (12 + 4 keys)	IC750KBL400	12	0.3
Keyblock Module - 8 keys	IC750KBL840	12	0.3
Keyblock Module - 4 keys	IC750KBL440	12	0.3
Keyblock Module - Blank module	IC750KBL000	N/A	N/A
Keyblock Module - Emergency Stop - key	IC750KBL910	N/A	N/A
Keyblock Module - Key switch	IC750KBL920	N/A	N/A
Keyblock Module - Start/Stop	IC750KBL930	N/A	N/A
Basic Panel Controller C200	IC750CTR200	150	3.6
Genius Panel Controller C400	IC750CTR400	185	4.4

2

- 24 VDC power requirements
 - Panel Controller, 5-2
- 24 VDC power supply
 - C200, 5-5

A

- Accessories
 - Display modules, 3-10
 - Keyblock label sheets, 6-4
 - Keyblock modules, 4-16
 - lamps for Keyblock modules, 6-5
 - lithium battery, 6-3
 - mounting bezels, 6-5
 - Panel Controllers, 5-15
 - RS-232/RS-422 serial cables, 6-5
- Accessories set, 6-2
- Assembly tips, 2-3

B

- Backlight, 3-2
- Basic Panel Controller (C200)
 - 24 VDC power supply, 5-5
 - connections and operational elements, 5-4
 - IF0 - RS-232, 5-5
 - IF1 - RS232, 5-6
 - IF2 - RS-422 / RS-485, 5-6
 - Lithium Battery, 5-7
 - number switch, 5-7
 - overview, 5-3
 - Reset button, 5-7
- Blank module, 4-11

C

- Cables
 - RS-232 serial, 6-5
 - RS-422 serial, 6-5
- Cabling schematic
 - Controller to PC, A-3
 - for printers, 7-3
- Catalog numbers
 - accessories set, 6-2
 - bezels, 2-6
 - lithium battery, 2-26, 6-3
 - mounting bezels, 6-5
 - PANELWARE modules, 1-15
 - replacement lamps, 4-16
 - serial cables, 6-5, A-3
- Character sets
 - character-oriented LCD displays, B-6

- for character-oriented LCD Displays, B-6
- Cleaning the display and keys, 2-4
- Connecting power to Controller, 5-2
- Connections
 - C200, 5-4
 - C400, 5-9
 - cabling, A-2
 - Display Module to Panel Controller, 3-3
 - Keyblock module to Keyblock module, 4-5
 - Keyblock module to Panel Controller, 4-5
 - Panel Controller to PC, A-2
 - printer to Panel Controller, 7-2
- Contrast, 3-2
- C-UL listing, 1-3
- Cutouts for system, 2-5

D

- Device number switch
 - C400, 5-11
- Dimensions of Keyblock modules, 4-2
- Display Modules
 - 2 x 20 LCD, 3-4
 - 2 x 20 VFD, 3-8
 - 2 x 40 VFD, 3-9
 - 4 x 20 LCD, 3-5
 - 4 x 40 LCD, 3-6
 - 8 x 40 LCD, 3-7
 - accessories, 3-10
 - Backlight, 3-2
 - Connection to the Panel Controller, 3-3
 - contrast, 3-2
 - Overview, 1-6
 - With LCD Displays, 3-4
 - With VFD Displays, 3-8

E

- Emergency Stop switch module, 4-12
- Error messages, 8-3

F

- FlashPROM, 5-13

G

- General Information
 - Controllers, 5-2
 - Display Modules, 3-2
 - Keyblock modules, 4-2
 - Operator Interface Panels, 1-2
 - system assembly, 2-2
 - troubleshooting / error diagnosis, 8-2
- GENIUS bus connector
 - C400, 5-11

Genius Panel Controller (C400)
24 VDC power supply, 5-10
connections and operational elements, 5-9
device number switch, 5-11
GENIUS bus connector, 5-11
IF0 - RS-232, 5-10
lithium battery, 5-12
operating mode switch, 5-11
reset button, 5-12
Grounding recommendations, 2-4

I

IF0 - RS-232
C200, 5-5
C400, 5-10
IF1 - RS-232
C200, 5-6
IF2 - RS-422 / RS-485
C200, 5-6
Inserting/exchanging Keyblock labels, 2-12
Installation options, 2-5
Installing/replacing the Controller battery, 2-26
Interface Panels
Components, 1-4
Intelligent Panels, 1-4
Operation, 1-4
IP54 rating, 1-3, 2-4

K

Key switch module, 4-13
Keyblock
cables, 4-4
Keyblock cables, 4-4
Keyblock labels, 4-3
inserting/exchanging, 2-12
ordering information, 6-4
Keyblock Modules
16 Keys, 4-7
4 keys, 4-10
8 keys, 4-9
accessories, 4-16
blank, 4-11
connections, 4-5
dimensions, 4-2
Emergency Stop switch, 4-12
general information, 4-2
key switch, 4-13
labels, 4-3
numeric, 4-8
Overview, 1-8
special, 4-11
Start/Stop, 4-15
types, 4-3

L

Lamps for Keyblock modules
ordering information, 4-16, 6-5
Lithium battery, 5-7
C400, 5-12
installing/replacing, 2-26
ordering information, 6-3

M

Mounting bezels
ordering information, 6-5
overview, 2-6

N

NEMA 12 rating, 1-3, 2-4
Number switch
C200, 5-7

O

Operating mode switch
C400, 5-11
Operating system
reloading, 5-15
Operational elements
C200, 5-4
C400, 5-9
Operator Interface Panel Basics, 1-2
Operator Panel Hook-up
Panel to PLC, 1-13
Operator Panels
Hook-up, 1-13
Programming, 1-14
Ordering information, 1-15

P

Package contents, 2-9
display module type 1, 2-9
display module type 2, 2-9
Panel Controller C200, 2-11
special Keyblock modules, 2-10
standard Keyblock modules, 2-10
Panel assembly, 2-15
Panel Components, 1-4
Panel configurations, 2-4
Panel Controllers
24 VDC power, 5-2
accessories, 5-15
C200, 5-3
C400, 5-8
connecting power, 5-2

- connecting to printers, 7-2
- FlashPROM, 5-13
- loading panel program, 5-14
- loading/starting Panel programs, 5-14
- Overview, 1-11
- reloading the operating system, 5-15
- RESET modes, 5-13
- setting number switches, 5-2
- starting panel program, 5-14
- update mode, 5-15
- Panel disassembly, 2-23
- Panel installation, 2-19
- Panel programs
 - loading, 5-14
 - overview, 5-14
 - starting, 5-14
- Panel removal, 2-21
- PANELWARE Operator Panels, 1-5
 - Basic Elements, 1-5
 - Hook-up, 1-13
 - Modular Concept, 1-5
 - Programming, 1-14
- PANELWARE Panel Ratings, 1-3
- PC connections
 - to Panel Controller, A-2
- Power connection, 2-4
- Power supply
 - 24 VDC, 5-10
- Powering on for the first time, 8-2
- Printers
 - cabling schematic, 7-3
 - connecting to Panel Controller, 7-2
- Programming Operator Panels, 1-14

R

- Reloading the operating system, 5-15
- Reset button
 - C200, 5-7
 - C400, 5-12
- RESET modes, 5-13

S

- Serial cables
 - ordering information, 6-5
- Setting number switches, 5-2
- Special Keyblock module, 4-11
- Start/Stop module, 4-15
- Starting an application, 8-2
- System assembly
 - component descriptions, 2-2
 - cutouts, 2-5
 - general information, 2-2
 - inserting/exchanging Keyblock labels, 2-12
 - installation options, 2-5

- installing/replacing the Controller battery, 2-26
- mounting bezels, 2-6
- Panel assembly, 2-15
- panel disassembly, 2-23
- Panel installation, 2-19
- panel removal, 2-21
- tips, 2-3
- tools required, 2-2

T

- Tools required for assembly, 2-2
- Troubleshooting/error diagnosis
 - other errors, 8-4
 - powering on for the first time, 8-2
 - starting an application, 8-2
 - visual check, 8-2

U

- UL listing, 1-3
- Update mode, 5-15

V

- Visual check, 8-2