



DIAX04 HDD and HDS Drive Controllers 2nd Generation

Project Planning Manual

SYSTEM200

Title	DIAX04 HDD and HDS Drive Controller 2nd Generation
Type of Documentation	Project Planning Manual
Document Typecode	DOK-DIAX04-HDD+HDS**G2-PR03-EN-P
Internal File Reference	<ul style="list-style-type: none"> 120-0800-B330-03/EN

Purpose of Documentation This documentation describes:

- to develop the electro-construction
- to assist in mounting the drive controller into the control cabinet
- to assist in the installation of the drive package

Record of Revisions

Description	Release Date	Notes
DOK-DIAX04-HDD+HDS**G2-PRJ1-EN-P	06.1998	1 st release
DOK-DIAX04-HDD+HDS**G2-PR02-EN-P	03.2000	1 st revision
DOK-DIAX04-HDD+HDS**G2-PR03-EN-P	01.2001	2 nd revision

Copyright © 2001 Rexroth Indramat GmbH

Copying this document, giving it to others and the use or communication of the contents thereof without express authority, are forbidden. Offenders are liable for the payment of damages. All rights are reserved in the event of the grant of a patent or the registration of a utility model or design (DIN 34-1).

Validity All rights are reserved with respect to the content of this documentation and the availability of the product.

Published by Rexroth Indramat GmbH
Bgm.-Dr.-Nebel-Str. 2 • D-97816 Lohr a. Main
Telephone 09352/40-0 • Tx 689421 • Fax 09352/40-4885
<http://www.rexroth.com/indramat>
Dept. ECD (jg/hp)

Note This document has been printed on chlorine-free bleached paper..

Supplementary documentation

Note: The following documentation is not required in its entirety for the correct use of the drive controllers HDD and HDS.

"List of Connecting Cables for DIAX04 and ECODRIVE03"

- Selection lists -

DOK-CONNEX-CABLE*STAND-AUxx-EN-P

"LWL - Handling"

- Application Manual -

DOK-CONNEX-CABLE*LWL-AWxx-EN-P

"Electromagnetic Compatibility (EMC) in Drive and Control Systems"

- Project Planning Manual -

DOK-GENEERL-EMV*****-PRxx-EN-P

DIAX04 Drive With Electric Gear Function

- Functional Description

DOK-DIAX04-ELS-05VRS**FKB1-EN-P

DIAX04 Drive With Electric Gear Function

- Troubleshooting Guide

DOK-DIAX04-ELS-05VRS**-WAR1-EN-P

DIAX04 Drive With Servo Function

- Functional Description

DOK-DIAX04-SSE-01VRS**FKB1-EN-P

DIAX04 Drive With Servo Function

- Troubleshooting Guide

DOK-DIAX04-SSE-01VRS**-WAR1-EN-P

DIAX04 Drive With Servo Function

- Functional Description

DOK-DIAX04-SSE-02VRS**FKB1-EN-P

DIAX04- Drive With Servo Function

- Troubleshooting Guide

DOK-DIAX04-SSE-02VRS**-WAR1-EN-P

-DIAX04 Drive With Servo Function

- Functional Description

DOK-DIAX04-SSE-03VRS**-FK01-EN-P

-DIAX04 Drive With Servo Function
- Troubleshooting Guide
DOK-DIAX04-SSE-03VRS**-WA01-EN-P

DIAX04 Drive With Main Spindle Function, SERCOS interface
- Functional Description
DOK-DIAX04-SHS-03VRS**-FK01-EN-P

DIAX04 Drive With Main Spindle Function, SERCOS interface
-Troubleshooting Guide
DOK-DIAX04-SHS-03VRS**-WA01-EN-P

DIAX04 Drive With Servo Function, Analog- and Parallelinterface
- Functional Description
DOK-DIAX04-ASE-02VRS**FKB1-EN-P

DIAX04 Drive With Servo Function, Analog- and Parallelinterface
-Troubleshooting Guide
DOK-DIAX04-ASE-02VRS**-WAR1-EN-P

DIAX04 Drive With Main Spindle Function, Analog And
Parallelinterface
- Functional Description
DOK-DIAX04-AHS-03VRS**FKB1-EN-P

DIAX04 Drive With Main Spindle Function, Analog And
Parallelinterface
-Troubleshooting Guide
DOK-DIAX04-AHS-03VRS**-WAR1-EN-P

"Digital AC Motors MKD"
- Project Planning Manual -
DOK-MOTOR*-MKD*****-PRxx-EN-P

"Digital AC Motors MHD"
- Project Planning Manual -
DOK-MOTOR*-MHD*****-PRxx-EN-P

"MKE Digital AC Motors for potentially explosive areas"
- Project Planning Manual -
DOK-MOTOR*-MKE*****-PRxx-EN-P

"2AD AC Motor"
- Project Planning Manual -
DOK-MOTOR*-2AD*****-PRxx-EN-P

"ADF Main Spindle Motors"
- Project Planning Manual -
DOK-MOTOR*-ADF*****-PRxx-EN-P

"1MB Frameless Spindle Motor"
- Project Planning Manual -
DOK-MOTOR*-1MB*****-PRxx-EN-P

"Synchronous MBS Kit Spindle Motors"
- Project Planning Manual -
DOK-MOTOR*-MBS*****-PRxx-EN-P

LAR 070-132 Housing Linear Motor
- Selection and Project Planning -
DOK-MOTOR*-LAR*****-AWxx-EN-P

"LAF050 – 121 Linear Motors"
- Selection and Project Planning -
DOK-MOTOR*-LAF*****-AWxx-EN-P

"Linear Synchronous Direct Drives LSF"
- Project Planning Manual -
DOK-MOTOR*-LSF*****-PRxx-EN-P

"AC Drive Units in Personnel Conveyor Systems"
- Application Manual -
DOK-GENERL-ANTR*PERSON-ANxx-EN-P

"AC Drive Units in Hazardous Areas (Expl. Protection)"
- Application Manual -
DOK-GENERL-ANTR*EXPLOS-ANxx-EN-P

Changes from previous Version:**DOK-DIAX04-HDD+HDS**-PRJ1-EN-P**

Where?	What?
Chapter 2	Safety Instructions inserted
Chapter 3	Important directions for use inserted
Chapter 5	restructured
Page: 5-3	Illustration reworked
Page: 5-4	Illustration reworked
Page: 5-5	X1 Illustration and Description added
Page: 5-6	X2 Illustration and Description added
Page: 5-9	X3 Illustration and Description added
Page: 5-11	X4 Illustration and Description added
Page: 5-12	X5 Illustration and Description added
Page: 5-15	X6 Illustration and Description added
Page: 6-2	Dimensional sheet HDD02.2 reworked
Page: 6-3	Dimensional sheet HDS02.2 reworked
Page: 6-4	Dimensional sheet HDS03.2 reworked
Page: 6-5	Dimensional sheet HDS04.2 reworked
Page: 6-6	Dimensional sheet HDS05.2 added
Chapter 6-2	Calculation of the drive controller losses added
Chapter 4-6	HDS 5.2 included

Fig. : Changes from previous Version:

Changes from previous Version:**DOK-DIAX04-HDD+HDS**-PR02-EN-P**

Where?	What?
Chapter 1	Fig. 1-1: Graphical diagram, updated
Chapter 4	Technical data, adjusted
Chapter 5	Drive controller HDD02.2-W40N-HD32 added
Chapter 6	HDS connector assignment, updated
Chapter 7	X7.1/X7.2: positioning interface for sinusoidal signals included
Chapter 7	X10 / X11: SERCOS interface included
Chapter 7	X12.1 / X12.2: external inputs included
Chapter 10	Type labels of the HDD drive controller added

Fig. : Changes from previous Version

Note: The list may be incomplete. The author witholds the right to make small changes which do not appear in this list.

Contents

1	Introducing the system	1-1
1.1	Drive package - DIAX04.....	1-1
1.2	The individual components of the digital DIAX04 drive	1-2
1.3	Supply units.....	1-2
1.4	Additional units.....	1-2
2	Safety Instructions for Electric Servo Drives and Controls	2-1
2.1	Introduction.....	2-1
2.2	Explanations.....	2-1
2.3	Hazards by inappropriate use	2-2
2.4	General Information	2-3
2.5	Protection against contact with electrical parts.....	2-4
2.6	Protection by protective low voltage (PELV) against electrical shock	2-6
2.7	Protection against dangerous movements.....	2-6
2.8	Protection against magnetic and electromagnetic fields during operations and mounting.....	2-8
2.9	Protection against contact with hot parts	2-9
2.10	Protection during handling and installation	2-9
2.11	Battery safety	2-10
2.12	Protection against pressurized Systems.....	2-10
3	Important directions for use	3-1
3.1	Appropriate use.....	3-1
	Introduction	3-1
	Areas of use and application.....	3-2
3.2	Inappropriate use	3-2
4	Drive controllers HDS	4-1
4.1	Configured drive controller	4-1
4.2	Drive controller, basic unit.....	4-2
4.3	Command communication modules.....	4-2
4.4	Software module	4-2
4.5	Additional plug-in modules	4-2
4.6	Configuration type plate	4-4
4.7	Type codes of the configured drive controller	4-5
4.8	Technical data - an overview	4-6
4.9	Ambient conditions and installation elevation	4-8
5	Drive Controller HDD02.2-W040N-HD32	5-1
5.1	General information.....	5-1
5.2	Type codes of the HDD02.2-W040-HD32	5-2
5.3	Technical data - (an overview).....	5-2

5.4	Ambient conditions and installation elevation	5-2
6	Planning the electrical connections	6-1
6.1	General information.....	6-1
4.2	Connecting the basic unit.....	6-2
	X1, Connector for integrated bus connections from the neighboring unit	6-7
	X2, Serial interface.....	6-8
	X3 Analog outputs, ready to operate, starting lockout.....	6-11
	X4, Motor feedback connector (encoder 1)	6-13
	X5 Intermediate circuit, motor, and power connections.....	6-15
	X6 Holding brake, motor temperature monitoring.....	6-18
	X7.1/X7.2 Motor feedback connector (encoder 2).....	6-20
	X10/X11: SERCOS interface (HDD).....	6-23
	X12.1/X12.2 External inputs (HDD)	6-25
7	Planning the design of the control cabinet	7-1
7.1	Dimensional sheet.....	7-1
7.2	Calculation of the drive controller losses	7-1
7.3	The use of cooling system in the control cabinet.....	7-6
7.4	Connection lines.....	7-8
4.5	Measures against interference sources in the control cabinet.....	7-9
8	Accessories	8-1
8.1	Optic Fiber (OF)	8-1
9	Transport and storage	9-1
9.1	General instructions	9-1
10	Identifying the merchandise	10-1
10.1	Delivery note and barcode sticker.....	10-1
10.2	Type plates of the drive controller HDS	10-2
10.3	Type plates of the drive controller HDD	10-3
10.4	Other type plates.....	10-4
11	Mounting and installation	11-1
11.1	Mounting the drive controller.....	11-1
11.2	Installation	11-3
12	Service and testing	12-1
12.1	Error diagnoses.....	12-1
12.2	Repairs and replacements	12-1
12.3	High voltage check and insulation check.....	12-2
13	Index	13-1
14	Service & Support	14-1

14.1 Helpdesk 14-1

14.2 Service-Hotline..... 14-1

14.3 Internet - Worldwide Web 14-1

14.4 Vor der Kontaktaufnahme... ..before contacting us 14-1

14.5 Kundenbetreuungsstellen Sales & Service Facilities..... 14-2

Notes

1 Introducing the system

1.1 Drive package - DIAX04

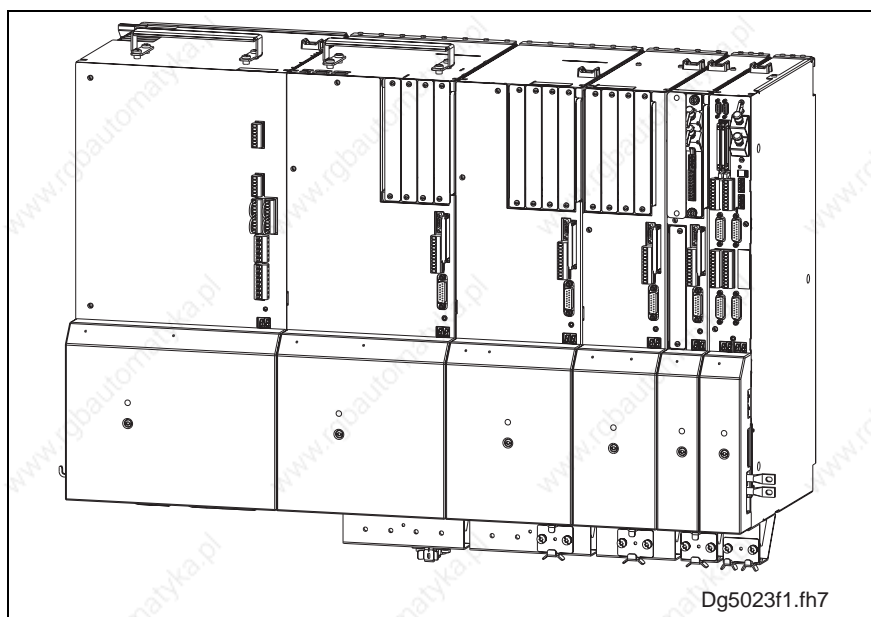

Fig. 1-1: Digital intelligent drive system - DIAX04

The modular concept of the DIAX04 Rexroth Indramat drive enables a flexible combination of AC drives to create compact drive packages implementing but one supply unit.

Together with MKD, MHD, 1MB and 2AD AC motors, HDD and HDS drives are rapid-response drives, suitable as servo and main drives, capable of being used in such tasks as machine tools, textile, printing and packaging machines, or in robotics and handling machines.

1.2 The individual components of the digital DIAX04 drive

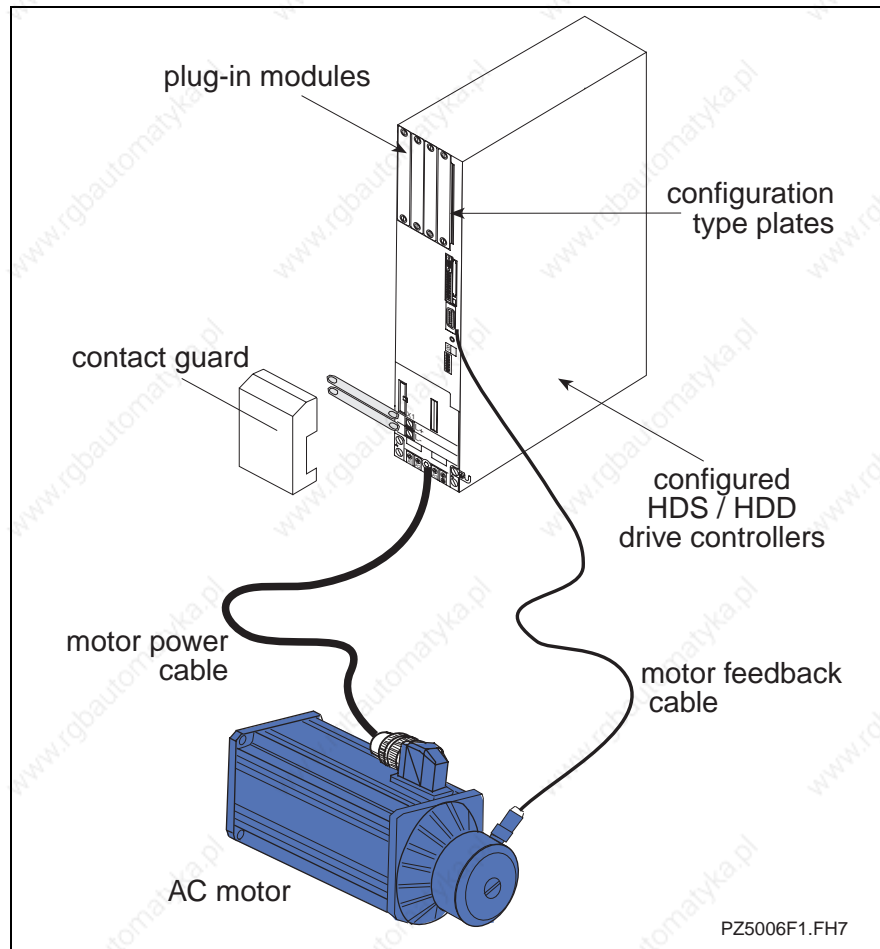

Fig. 1-2: Individual components of the digital drive

1.3 Supply units

HDD and HDS drive controllers are intended for connection to a HVE or HVR supply module. These modules supply all the signal and power voltages which the controller requires.

See also documentation "DOK-POWER*-HVE+HVR**G2-AWXX-XX-P"

1.4 Additional units

If a power supply system is not capable of regeneration and if the drive performance required is high, an additional brake resistor HZB may be necessary to control the energy generated from breaking.

If the number of start-stop cycles is high, it may be necessary to use an additional capacitor module HZK.

Moreover, a power connection module HZF is available.

Information on these products can be found in the following documentation: "DOK-POWER*-HVE+HVR**G2-AWXX-XX-P"

2 Safety Instructions for Electric Servo Drives and Controls

2.1 Introduction

Read these instructions before the equipment is used and eliminate the risk of personal injury or property damage. Follow these safety instructions at all times.

Do not attempt to install, use or service this equipment without first reading all documentation provided with the product. Read and understand these safety instructions and all user documentation of the equipment prior to working with the equipment at any time. If you do not have the user documentation for your equipment contact your local Rexroth Indramat representative to send this documentation immediately to the person or persons responsible for the safe operation of this equipment.

If the product is resold, rented or transferred or passed on to others, then these safety instructions must be delivered with the product.



Inappropriate use of this equipment, failure to follow the safety instructions in this document or tampering with the product, including disabling of safety devices, may result in product damage, personal injury, severe electrical shock or death!

2.2 Explanations

The safety warnings in this documentation describe individual degrees of hazard seriousness in compliance with ANSI:



Warning symbol with signal word	Degree of hazard seriousness
 DANGER	The degree of hazard seriousness describes the consequences resulting from non-compliance with the safety guidelines. Bodily harm or product damage will occur.
 WARNING	Death or severe bodily harm may occur.
 CAUTION	Death or severe bodily harm may occur.

Fig. 2-1: Classes of danger with ANSI

2.3 Hazards by inappropriate use



DANGER

**High voltage and high discharge current!
Danger to life, risk of severe electrical shock
and risk of injury!**



DANGER

**Dangerous movements! Danger to life and risk
of injury or equipment damage by unintentional
motor movements!**



WARNING

**High electrical voltage due to wrong
connections! Danger to life, severe electrical
shock and severe bodily injury!**



WARNING

**Health hazard for persons with heart
pacemakers, metal implants and hearing aids in
proximity to electrical equipment!**



CAUTION

**Surface of machine housing could be extremely
hot! Danger of injury! Danger of burns!**



CAUTION

**Risk of injury due to inappropriate handling!
Bodily injury caused by crushing, shearing,
cutting and mechanical shock or improper
handling of pressurized systems!**



CAUTION

**Risk of injury due to inappropriate handling of
batteries!**

2.4 General Information

Rexroth Indramat GmbH is not liable for damages resulting from failure to observe the warnings given in these documentation.

Order operating, maintenance and safety instructions in your language before starting up the machine. If you find that due to a translation error you can not completely understand the documentation for your product, please ask your supplier to clarify.

Proper and correct transport, storage, assembly and installation as well as care in operation and maintenance are prerequisites for optimal and safe operation of this equipment.

Trained and qualified personnel in electrical equipment:

Only trained and qualified personnel may work on this equipment or within its proximity. Personnel are qualified if they have sufficient knowledge of the assembly, installation and operation of the product as well as an understanding of all warnings and precautionary measures noted in these instructions.

Furthermore, they should be trained, instructed and qualified to switch electrical circuits and equipment on and off, to ground them and to mark them according to the requirements of safe work practices and common sense. They must have adequate safety equipment and be trained in first aid.

Only use spare parts and accessories approved by the manufacturer.

Follow all safety regulations and requirements for the specific application as practiced in the country of use.

The equipment is designed for installation on commercial machinery.

European countries: see directive 89/392/EEC (machine guideline).

The ambient conditions given in the product documentation must be observed.

Use only safety features that are clearly and explicitly approved in the Project Planning manual.

For example, the following areas of use are not allowed: Construction cranes, Elevators used for people or freight, Devices and vehicles to transport people, Medical applications, Refinery plants, the transport of hazardous goods, Radioactive or nuclear applications, Applications sensitive to high frequency, mining, food processing, Control of protection equipment (also in a machine).

Start-up is only permitted once it is sure that the machine, in which the product is installed, complies with the requirements of national safety regulations and safety specifications of the application.

Operation is only permitted if the national EMC regulations for the application are met.

The instructions for installation in accordance with EMC requirements can be found in the INDRAMAT document "EMC in Drive and Control Systems".

The machine builder is responsible for compliance with the limiting values as prescribed in the national regulations and specific EMC regulations for the application.

European countries: see Directive 89/336/EEC (EMC Guideline).

U.S.A.: See National Electrical Codes (NEC), National Electrical Manufacturers Association (NEMA), and local building codes. The user of this equipment must consult the above noted items at all times.

Technical data, connections and operational conditions are specified in the product documentation and must be followed at all times.

2.5 Protection against contact with electrical parts

Note: This section refers to equipment with voltages above 50 Volts.

Making contact with parts conducting voltages above 50 Volts could be dangerous to personnel and cause an electrical shock. When operating electrical equipment, it is unavoidable that some parts of the unit conduct dangerous voltages.



DANGER

High electrical voltage! Danger to life, severe electrical shock and severe bodily injury!

- ⇒ Only those trained and qualified to work with or on electrical equipment are permitted to operate, maintain or repair this equipment.
- ⇒ Follow general construction and safety regulations when working on electrical installations.
- ⇒ Before switching on power the ground wire must be permanently connected to all electrical units according to the connection diagram.
- ⇒ Do not operate electrical equipment at any time if the ground wire is not permanently connected, even for brief measurements or tests.
- ⇒ Before working with electrical parts with voltage potentials higher than 50 V, the equipment must be disconnected from the mains voltage or power supply.
- ⇒ The following should be observed with electrical drives, power supplies, and filter components:
Wait five (5) minutes after switching off power to allow capacitors to discharge before beginning work. Measure the voltage on the capacitors before beginning work to make sure that the equipment is safe to touch.
- ⇒ Never touch the electrical connection points of a component while power is turned on.
- ⇒ Install the covers and guards provided with the equipment properly before switching the equipment on. Prevent contact with live parts at any time.
- ⇒ A residual-current-operated protective device (r.c.d.) must not be used on an electric drive! Indirect contact must be prevented by other means, for example, by an overcurrent protective device.
- ⇒ Equipment that is built into machines must be secured against direct contact. Use appropriate housings, for example a control cabinet.

European countries: according to EN 50178/1998, section 5.3.2.3.

U.S.A: See National Electrical Codes (NEC), National Electrical Manufacturers Association (NEMA) and local building codes. The user of this equipment must observe the above noted instructions at all times.

To be observed with electrical drives, power supplies, and filter components:



DANGER

**High electrical voltage! High leakage current!
Danger to life, danger of injury and bodily harm
from electrical shock!**

- ⇒ Before switching on power for electrical units, all housings and motors must be permanently grounded according to the connection diagram. This applies even for brief tests.
- ⇒ Leakage current exceeds 3.5 mA. Therefore the electrical equipment and units must always be firmly connected to the supply network.
- ⇒ Use a copper conductor with at least 10 mm² cross section over its entire course for this protective connection!
- ⇒ Prior to startups, even for brief tests, always connect the protective conductor or connect with ground wire. High voltage levels can occur on the housing that could lead to severe electrical shock and personal injury.

European countries: EN 50178/1998, section 5.3.2.1.

USA: See National Electrical Codes (NEC), National Electrical Manufacturers Association (NEMA), and local building codes. The user of this equipment must maintain the above noted instructions at all times.

2.6 Protection by protective low voltage (PELV) against electrical shock

All connections and terminals with voltages between 5 and 50 Volts on INDRAMAT products are protective low voltages designed in accordance with the following standards on contact safety:

International: IEC 364-4-411.1.5

EU countries: see EN 50178/1998, section 5.2.8.1.



WARNING

High electrical voltage due to wrong connections! Danger to life, severe electrical shock and severe bodily injury!

- ⇒ Only equipment, electrical components and cables of the protective low voltage type (PELV = Protective Extra Low Voltage) may be connected to all terminals and clamps with 0 to 50 Volts.
- ⇒ Only safely isolated voltages and electrical circuits may be connected. Safe isolation is achieved, for example, with an isolating transformer, an opto-electronic coupler or when battery-operated.

2.7 Protection against dangerous movements

Dangerous movements can be caused by faulty control or the connected motors. These causes are be various such as:

unclean or wrong wiring of cable connections

inappropriate or wrong operation of equipment

malfunction of sensors, encoders and monitoring circuits

defective components

software errors

Dangerous movements can occur immediately after equipment is switched on or even after an unspecified time of trouble-free operation.

The monitors in the drive components make faulty operation almost impossible. Regarding personnel safety, especially the danger of bodily harm and property damage, this alone should not be relied upon to ensure complete safety. Until the built-in monitors become active and effective, it must be assumed in any case that some faulty drive movements will occur. The extent of these faulty drive movements depends upon the type of control and the state of operation.

**DANGER****Dangerous movements! Danger to life and risk of injury or equipment damage!**

⇒ Personnel protection must be secured for the above listed reason by means of superordinate monitors or measures.

These are instituted in accordance with the specific situation of the facility and a danger and fault analysis conducted by the manufacturer of the facility. All the safety regulations that apply to this facility are included therein. By switching off, circumventing or if safety devices have simply not been activated, then random machine movements or other types of faults can occur.

Avoiding accidents, injury or property damage:

⇒ Keep free and clear of the machine's range of motion and moving parts. Prevent people from accidentally entering the machine's range of movement:

- use protective fences
- use protective railings
- install protective coverings
- install light curtains or light barriers

⇒ Fences must be strong enough to withstand maximum possible momentum.

⇒ Mount the emergency stop switch (E-stop) in the immediate reach of the operator. Verify that the emergency stop works before startup. Don't operate the machine if the emergency stop is not working.

⇒ Isolate the drive power connection by means of an emergency stop circuit or use a start-inhibit system to prevent unintentional start-up.

⇒ Make sure that the drives are brought to standstill before accessing or entering the danger zone.

⇒ Secure vertical axes against falling or slipping after switching off the motor power by, for example:

- Mechanically securing the vertical axes
- Adding an external brake / clamping mechanism
- Balancing and thus compensating for the vertical axes mass and the gravitational force

The standard equipment motor brake or an external brake controlled directly by the servo drive are not sufficient to guarantee the safety of personnel!

- ⇒ Disconnect electrical power to the equipment using a master switch and secure the switch against reconnection for:
 - maintenance and repair work
 - cleaning of equipment
 - long periods of discontinued equipment use
 - ⇒ Avoid operating high-frequency, remote control and radio equipment near electronics circuits and supply leads. If use of such equipment cannot be avoided, verify the system and the plant for possible malfunctions at all possible positions of normal use before the first start-up. If necessary, perform a special electromagnetic compatibility (EMC) test on the plant.
-

2.8 Protection against magnetic and electromagnetic fields during operations and mounting

Magnetic and electromagnetic fields generated by current-carrying conductors and permanent magnets in motors represent a serious health hazard to persons with heart pacemakers, metal implants and hearing aids.



WARNING

Health hazard for persons with heart pacemakers, metal implants and hearing aids in proximity to electrical equipment!

- ⇒ Persons with pacemakers, metal implants and hearing aids are not permitted to enter following areas:
 - Areas in which electrical equipment and parts are mounted, being operated or started up.
 - Areas in which parts of motors with permanent magnets are being stored, operated, repaired or mounted.
 - ⇒ If it is necessary for a person with a pacemaker to enter such an area, then a physician must be consulted prior to doing so. Pacemakers, that are already implanted or will be implanted in the future, have a considerable deviation in their resistance to interference. Due to the unpredictable behavior there are no rules with general validity.
 - ⇒ Persons with hearing aids, metal implants or metal pieces must consult a doctor before they enter the areas described above. Otherwise health hazards will occur.
-

2.9 Protection against contact with hot parts



CAUTION

Housing surfaces could be extremely hot! Danger of injury! Danger of burns!

- ⇒ Do not touch surfaces near the source of heat! Danger of burns!
- ⇒ Wait ten (10) minutes before you access any hot unit. Allow the unit to cool down.
- ⇒ Do not touch hot parts of the equipment, such as housings, heatsinks or resistors. Danger of burns!

2.10 Protection during handling and installation

Under certain conditions inappropriate handling and installation of parts and components may cause injuries.



CAUTION

Risk of injury through incorrect handling! Bodily harm caused by crushing, shearing, cutting and mechanical shock!

- ⇒ Observe general instructions and safety regulations during handling installation.
- ⇒ Use only appropriate lifting or moving equipment.
- ⇒ Take precautions to avoid pinching and crushing.
- ⇒ Use only appropriate tools. If specified by the product documentation, special tools must be used.
- ⇒ Use lifting devices and tools correctly and safely.
- ⇒ Wear appropriate protective clothing, e.g. safety glasses, safety shoes and safety gloves.
- ⇒ Never stay under suspended loads.
- ⇒ Clean up liquids from the floor immediately to prevent personnel from slipping.

2.11 Battery safety

Batteries contain reactive chemicals in a solid housing. Inappropriate handling may result in injuries or equipment damage.



CAUTION

Risk of injury through incorrect handling!

- ⇒ Do not attempt to reactivate discharged batteries by heating or other methods (danger of explosion and corrosion).
- ⇒ Never charge batteries (danger from leakage and explosion).
- ⇒ Never throw batteries into a fire.
- ⇒ Do not dismantle batteries.
- ⇒ Handle with care. Incorrect extraction or installation of a battery can damage equipment.

Note: Environmental protection and disposal! The batteries contained in the product should be considered as hazardous material for land, air and sea transport in the sense of the legal requirements (danger of explosion). Dispose batteries separately from other refuse. Observe the legal requirements given in the country of installation.

2.12 Protection against pressurized Systems

Certain Motors (ADS, ADM, 1MB etc.) and drives, corresponding to the information in the Project Planning manual, must be provided with and remain under a forced load such as compressed air, hydraulic oil, cooling fluid or coolant. In these cases, improper handling of the supply of the pressurized systems or connections of the fluid or air under pressure can lead to injuries or accidents.



CAUTION

Danger of injury when pressurized systems are handled by untrained personnel!

- ⇒ Do not attempt to disassemble, to open or to cut a pressurized system.
- ⇒ Observe the operation restrictions of the respective manufacturer.
- ⇒ Before the disassembly of pressurized systems, lower pressure and drain off the fluid or gas.
- ⇒ Use suitable protective clothing (for example protective eyewear, safety shoes and gloves)
- ⇒ Remove any fluid that has leaked out onto the floor immediately.

Note: Environmental protection and disposal! The fluids used in the operation of the pressurized system equipment is not environmentally compatible. Fluid that is damaging to the environment must be disposed of separate from normal waste. Observe the national specifications of the country of installation.

3 Important directions for use

3.1 Appropriate use

Introduction

Rexroth Indramat products represent state-of-the-art developments and manufacturing. They are tested prior to delivery to ensure operating safety and reliability.

The products may only be used in the manner that is defined as appropriate. If they are used in an inappropriate manner, then situations can develop that may lead to property damage or injury to personnel.

Note: Rexroth Indramat, as manufacturer, is not liable for any damages resulting from inappropriate use. In such cases, the guarantee and the right to payment of damages resulting from inappropriate use are forfeited. The user alone carries all responsibility of the risks.

Before using Rexroth Indramat products, make sure that all the prerequisites for an appropriate use of the products are satisfied:

- Personnel that in any way, shape or form uses our products must first read and understand the relevant safety instructions and be familiar with appropriate use.
- If the product takes the form of hardware, then they must remain in their original state, in other words, no structural changes are permitted. It is not permitted to decompile software products or alter source codes.
- Do not mount or put into operation damaged or faulty products.
- Make sure that the products have been installed in accordance with the regulations mentioned in the relevant documentation.

Areas of use and application

Drive controllers made by Rexroth Indramat are designed to control electrical motors and monitor their operation.

Control and monitoring of the motors may require additional sensors and actuators.

Note: The drive controllers may only be used with the accessories and parts specified in this document. If a component has not been specifically named, then it may not be either mounted or connected. The same applies to cables and lines.

Operation is only permitted in the specified configurations and combinations of components using the software and firmware as specified in the relevant function descriptions.

Every drive controller has to be programmed before starting it up, making it possible for the motor to execute the specific functions of an application.

The drive controllers of the DIAX04 family are designed for use in single or multiple-axis drive and control applications.

To ensure an application-specific use, the drive controllers are available with different drive power and different interfaces.

Typical applications of drive controllers belonging to the DIAX04 family are:

- handling and mounting systems,
- packaging and food processing machines,
- printing and paper processing machines and
- machine tools.

The drive controllers may only be operated under the assembly, installation and ambient conditions as described here (temperature, system of protection, humidity, EMC requirements, etc.) and in the position specified.

3.2 Inappropriate use

Using the drive controllers outside of the above-referenced areas of application or under operating conditions other than described in the document and the technical data specified is defined as "inappropriate use".

Drive controllers may not be used if

- they are subject to operating conditions that do not meet the above specified ambient conditions. This includes, for example, operation under water, in the case of extreme temperature fluctuations or extremely high maximum temperatures or if
- Rexroth Indramat has not specifically released them for that intended purpose. Please note the specifications outlined in the general safety instructions!

4 Drive controllers HDS

4.1 Configured drive controller

The structure of the drive controllers is modular. The basic unit is adapted to a respective function by outfitting it with different plug-in modules.

Rexroth Indramat supplies the drive controllers configured. The configuration is determined by the required functions.

A configured drive controller is made up of the following components:

- drive controller - basic unit
- command communications module
- software module
- additional plug-in modules
- configuration type plate

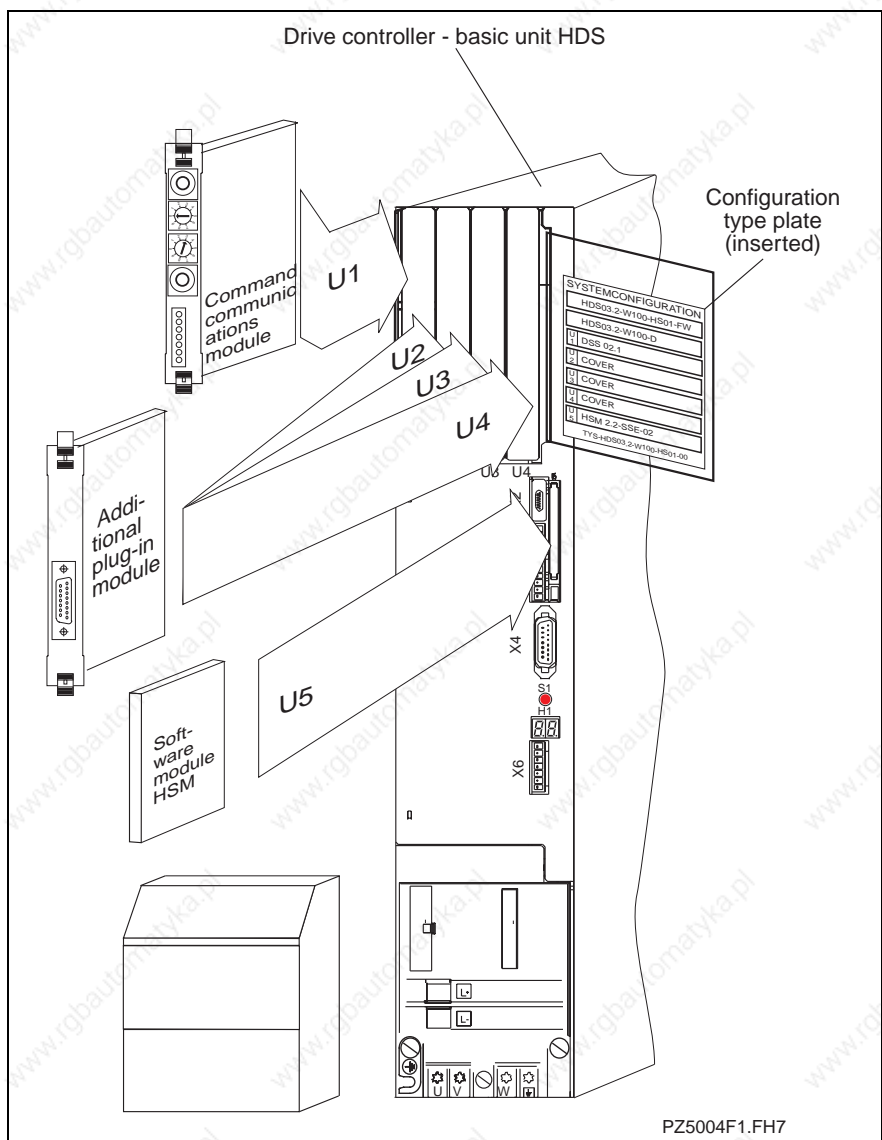

Fig. 4-1: Components of a configured drive controller

4.2 Drive controller, basic unit

The slots in the basic unit are empty.

4.3 Command communication modules

The term "Command communication module" defines various plug-in modules.

These plug-in modules are the interface to the control.

The following command communication modules are available:

- SERCOS interface type DSS02.1M
- ANALOG interface type DAE02.1M

4.4 Software module

Type: HSM

The software module contains the firmware of the drive (operating software) and stores all drive parameters. The firmware depends on the selected configuration and the desired functions.

In the event that the unit must be replaced, the drive parameters can simply be transferred to the replacement unit by inserting the software module. The drive is then immediately available again with its specified features.

4.5 Additional plug-in modules

The following plug-in modules are defined by the term "Additional plug-in module":

Digital I/O cards

Type: DEA04.1M, DEA05.1M, DEA06.1M

Digital interface cards for a bi-directional exchange of data, e.g. with a PLC. Each interface has 15 inputs and 16 outputs. The individual types are differentiated in terms of the internally set address.

Type: DEA08.1M, DEA09.1M, DEA10.1M

Type: DEA28.1M, DEA29.1M, DEA30.1M

Every interface has 32 inputs and 24 outputs as well as a CLC Bb-output.

Interface card for different measuring systems

Type: DEF01.1M, DEF02.1M

for connecting incremental measuring systems with square-wave signal output

Type: DLF01.1M

for connecting incremental measuring systems with sinusoidal signal output 1Vpp/11uApp

Type: DFF01.1M

for connecting singleturn GDS 1.1 measuring systems

Type: DAG01.2M

for connecting multiturn absolute encoders with SSI signal output

Type: DZF02.1M, DZF03.1M

for connecting Rexroth Indramat gear-type encoders

Type: DRF01.1M

for connecting measuring systems with analog output signals (e.g., resolver; maximum input voltage: +/-10V)

Note: Only one plug-in module, i.e. a DLF, DZF or DRF, may be used at one time. It is not possible to combine these cards!

Interface card

Type: DAK01.1M

The "ARCNET coupler card" is a plug-in card for use with the CLC-D control card and represents the interface to an ARCNET bus system.

Type: DAK02.1M

The DAQ02 plug-in module is a plug-in card for use with the CLC-D control card. With it, it is possible to link several CLCs in an application implementing several master axes.

This link can be a simple system, i.e. a primary ring only, or a redundant system, i.e., both a primary and secondary ring.

Type: DSA01.1M

The plug-in module "Absolute encoder emulator" generates absolute actual position values that correspond to SSI standards (Synchronous serial interface).

Integrated control

Type: CLC-D02.3M

Supports a centralized control of digital drive controllers in SYNAX applications. (For details see document "SYNAX - Synchronization of Machine Axes".)

Note: All plug-in modules are described in detail in the document "Plug-in modules for digital intelligent drive controllers"; documentation type DOK-DIAX04-PLUG*IN*MOD-PRxx-xx-P.

4.6 Configuration type plate

The configuration type plate records the type designations of

- the configured drive controller
- the basic unit
- the software module
- and the plug-in modules in slots
 - U1 to U4 in HDS
 - U1 to U2 in HDD

These type designations help identify which components are in which slots.

In the event of a problem, these type designations on the configuration type plate can be used to quickly identify the replacement parts needed.

Note: The configuration type plate identifies the modules the drive controller is equipped with. Prior to start-up, check to make sure that the drive controller is equipped with what is listed on the plate.

Any changes in the configuration should also be noted on the configuration type plate!

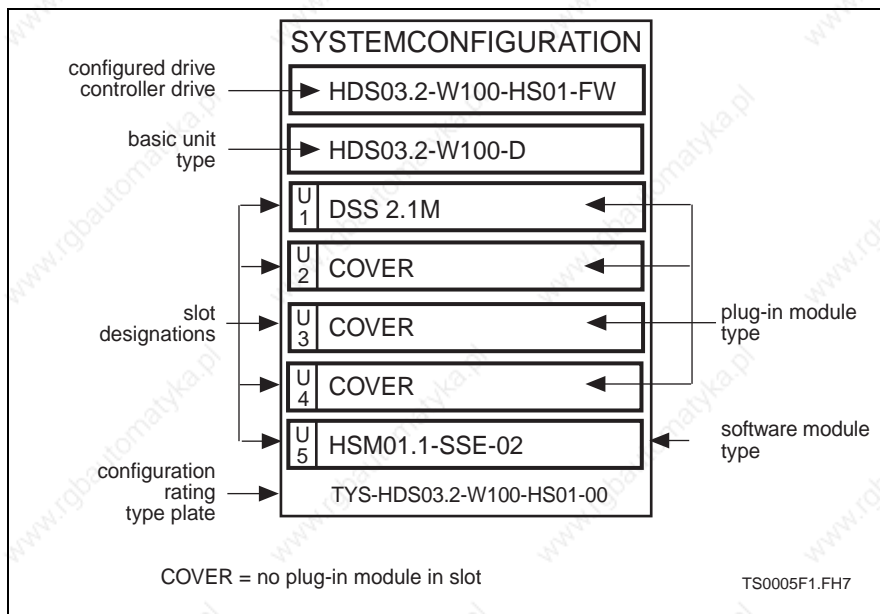

Fig. 4-2: An example of a configuration type plate HDS

4.7 Type codes of the configured drive controller

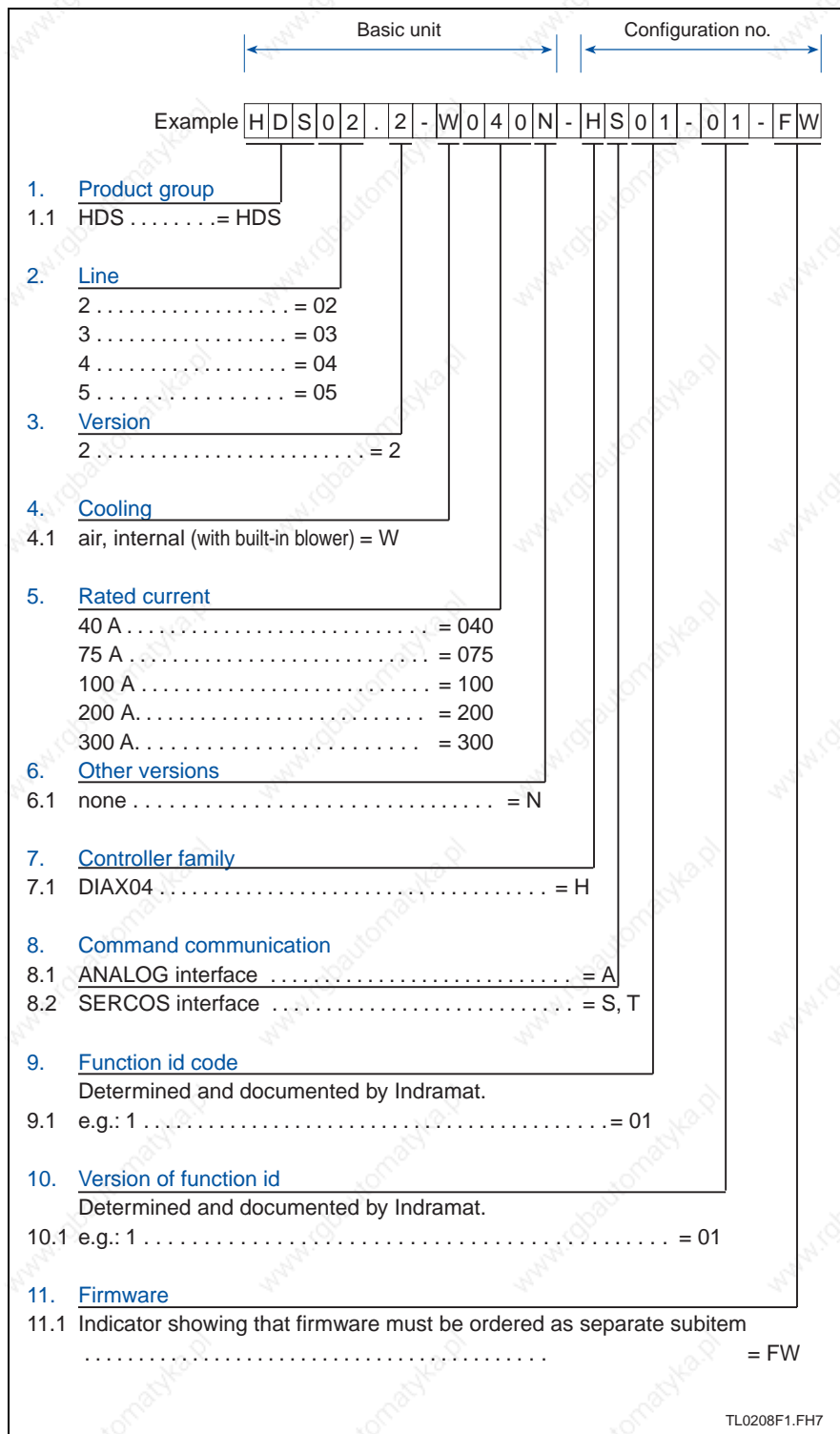

Fig. 4-3: Type codes HDS

4.8 Technical data - an overview

Designation	Symbol	Unit	HDD02.2- W040N -HD32	HDS02.2 -W040N	HDS03.2 -W075N	HDS03.2 -W100N	HDS04.2 -W200N	HDS05.2 -W300N
Rated current	I_{rated}	A	40	40	75	100	200	300
Peak current	I_{peak}	A	40 per axis	40	75	100	200	300
Continuous current (4kHz/8kHz)*	I_{cont}	A	15 / 10 per axis	20 / 15	40 / 30	50 / 35	120 / 80	175/100
Power loss with I_{cont}	P_v	W	110 per axis	125	220	280	800	1200
Weight	m	kg	8	6.5	11	11	19	25
Power consumption for signal processing from +/-26V-source	P_{26V}	W	40	20**)	25**)	25**)	30**)	55**)

*) Clock frequency of the power section

**) basic unit only; slide-in modules (configurations)
see also chapter 4.1 Drive controllers HDS

Ambient application		
Permissible ambient temperature range with rated data	° C	+5 ... +45
Maximum permissible ambient temperature with de-rated data	° C	+55
Storage and transport temperature	° C	-30 ... +85
Installation elevation without reduction of rated data	meters above sea level	max. 1000
Insulation classification		C as per DIN VDE 0110
Protection category		IP 10 per DIN 40 050

Fig. 4-4: Technical data of HDD and HDS

Power consumption of the plug-in modules

Plug-in module type	Power consumption (in W)
CLC-D02.3M-FW	6,0
DAE02.1M	1,2
DAG01.2M	3,3
DAK01.1M	2,1
DAQ02.1M	3,0
DBS03.1M-FW	3,0
DEA04.2M	1,6
DEA05.2M	1,6
DEA06.2M	1,6
DEA08.1M	1,6
DEA09.1M	1,6
DEA10.1M	1,6
DEA28.1M	1,6
DEA29.1M	1,6
DEA30.1M	1,6
DEF01.1M	4,5
DEF02.1M	4,5
DFF01.1M	3,6
DLF01.1M	5,4
DRF01.1M	3,4
DSA01.1M	8,0
DSS02.1M	1,5
DPF05.1M-FW	1,2
DZF02.1M	5,9
DZF03.1M	5,9

Fig. 4-5: Power consumption of the plug-in modules

4.9 Ambient conditions and installation elevation

- Rated data** The rated data of the controllers apply to
- ambient temperatures of +5° to +45° C
 - Installation elevations from 0 to 1000 meters above sea level.

Exceeding rated data If the controllers are to be used outside of the indicated range, then it is necessary to take the "load factors" into consideration. This reduces the output data.

⇒ In such cases as these, check whether the output data suffice for your application. To determine the load factors, please see Fig. 4-6. Values for temperature and installation exceeding those indicated are not permissible!



WARNING

Damage to units and loss of guarantee!

⇒ Controllers operated outside of specified ambient conditions could be damaged. The guarantee is also forfeited in such cases.

⇒ Please, therefore, note the following instructions!

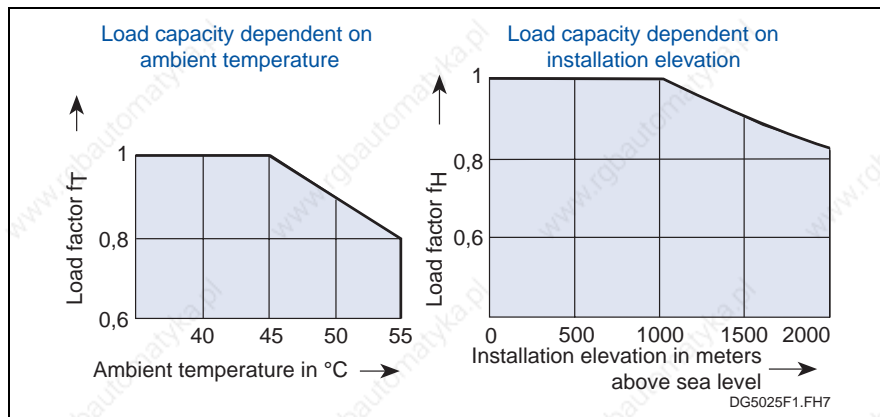

Fig. 4-6: Load factors as dependent on ambient temperature and installation elevation

If either the ambient temperature or the installation elevation exceed rated data:

- ⇒ Multiply the rated data listed in the technical data with the determined load factor.
- ⇒ Ascertain that the de-rated data still meets your application requirements.

If both the ambient temperature and the installation elevation exceed rated data:

- ⇒ Multiply the determined load factors f_T and f_H .
- ⇒ Multiply the resulting value with the rated data of the controller listed in the technical data.
- ⇒ Ascertain that your application requirements do not exceed the de-rated data .

Protection category The controller satisfies protection category IP10 as per EN 60 529, edition dated 10.91 (DIN VDE 0470-1).

It has been designed for mounting into a control cabinet or closed housing (as per EN 50175/1988, section 6.1.3).

5 Drive Controller HDD02.2-W040N-HD32

5.1 General information

The drive controller has a fixed configuration; it is able of activating two motors.

As regards the HDD02.2-W040-HD32, the SERCOS interface guide communication module (same as plug-in module DSS02.1M) and an additional connection for an incremental measuring system with 1-Vpp sinusoidal output is integrated per axis.

5.2 Type codes of the HDD02.2-W040-HD32

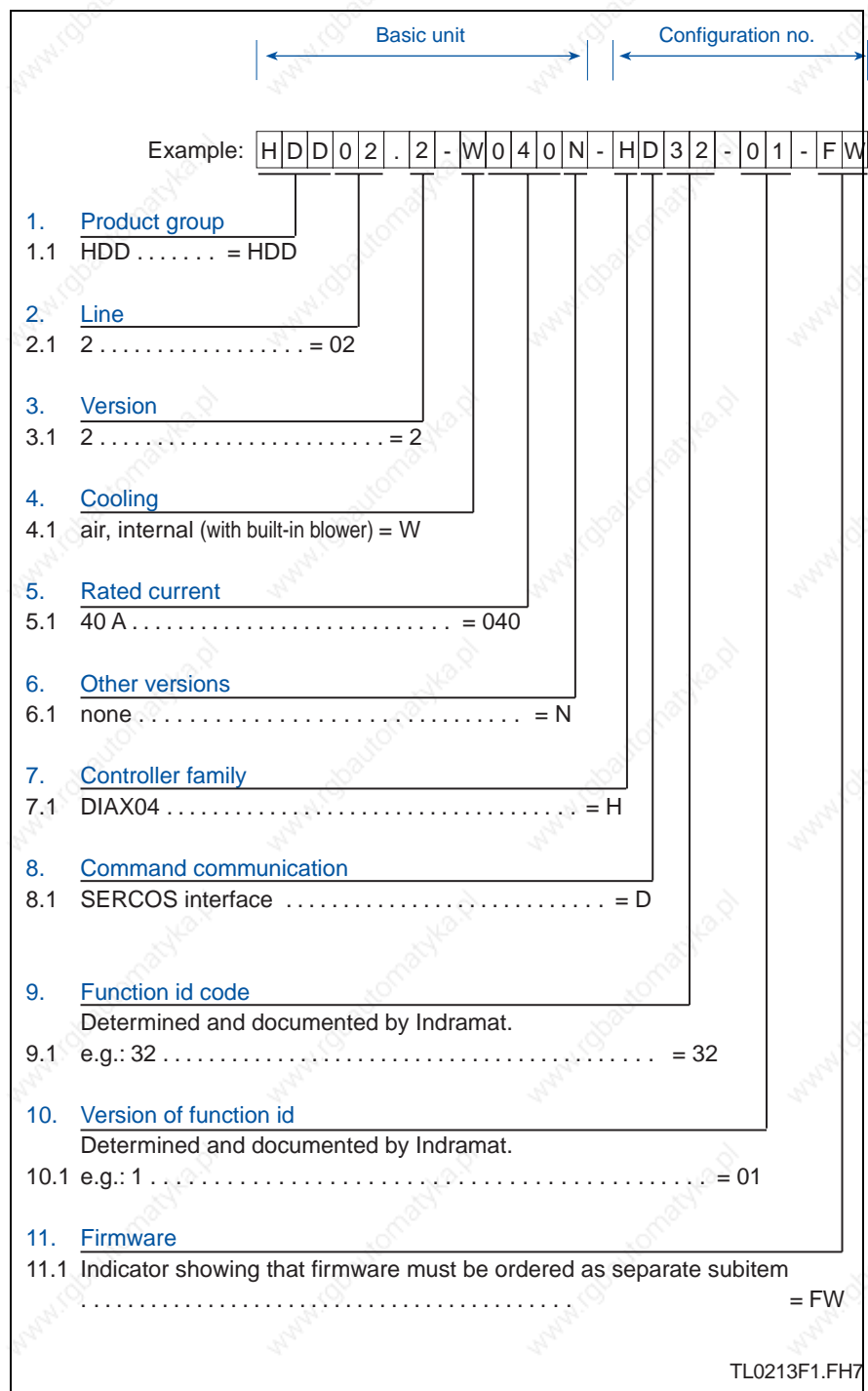

Fig. 5-1 Type codes HDD

5.3 Technical data - (an overview)

See also 4.8 Technical data - an overview

5.4 Ambient conditions and installation elevation

See also 4.9 Ambient conditions and installation elevation

6 Planning the electrical connections

6.1 General information

The electrostatic loads of persons and/or tools could damage either drive controllers or PCBs when discharging over such. Therefore, please note the following:



CAUTION

Damage to electronic components and interference with their safety of operation caused by electrostatic charges!

⇒ Objects coming into contact with components and circuit boards must be discharged by means of grounding. Otherwise errors may occur when triggering motors and moving elements.

These objects can be:

- the soldering iron used for soldering
- the human body (ground by touching a conductive, grounded object)
- parts and tools (placed on a conductive surface)

Parts at risk may only be stored or transported in conductive packaging.

Note: Rexroth Indramat's terminal diagrams exclusively support the development of the machine terminal diagrams. When wiring the machine, use the terminal diagrams of the machine manufacturer!

General notes

- Route signal supply lines separate of load supply lines due to interference.
- Analog signals (e.g. command and actual values) must be fed via shielded supply lines.
- Mains, DC bus and power wires may not be connected with control voltages or be permitted to come into contact with such.
- During the conduction of a high voltage check or insulation check of the electrical equipment of the machine, release or remove all connections of the machine to avoid damaging the electronic components within the machine (permissible as per VDE 0113). Rexroth Indramat drive components are high-voltage and insulation checked as per VDE 0160.

6.2 Connecting the basic unit

Overview

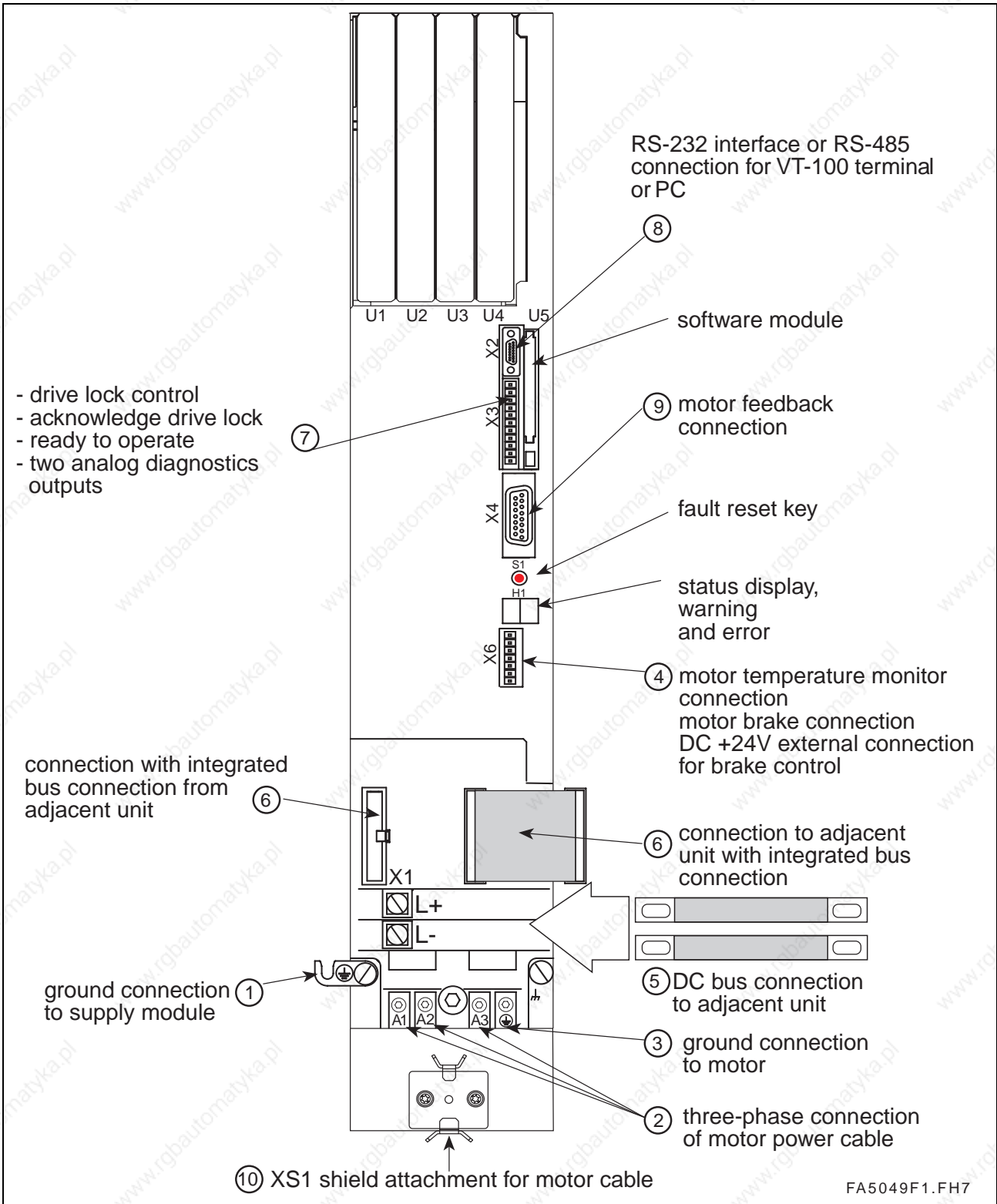

Fig. 6-1: Front view of the basic unit with connections labelled HDS

For explanation on points ① ⑩ see the following pages.

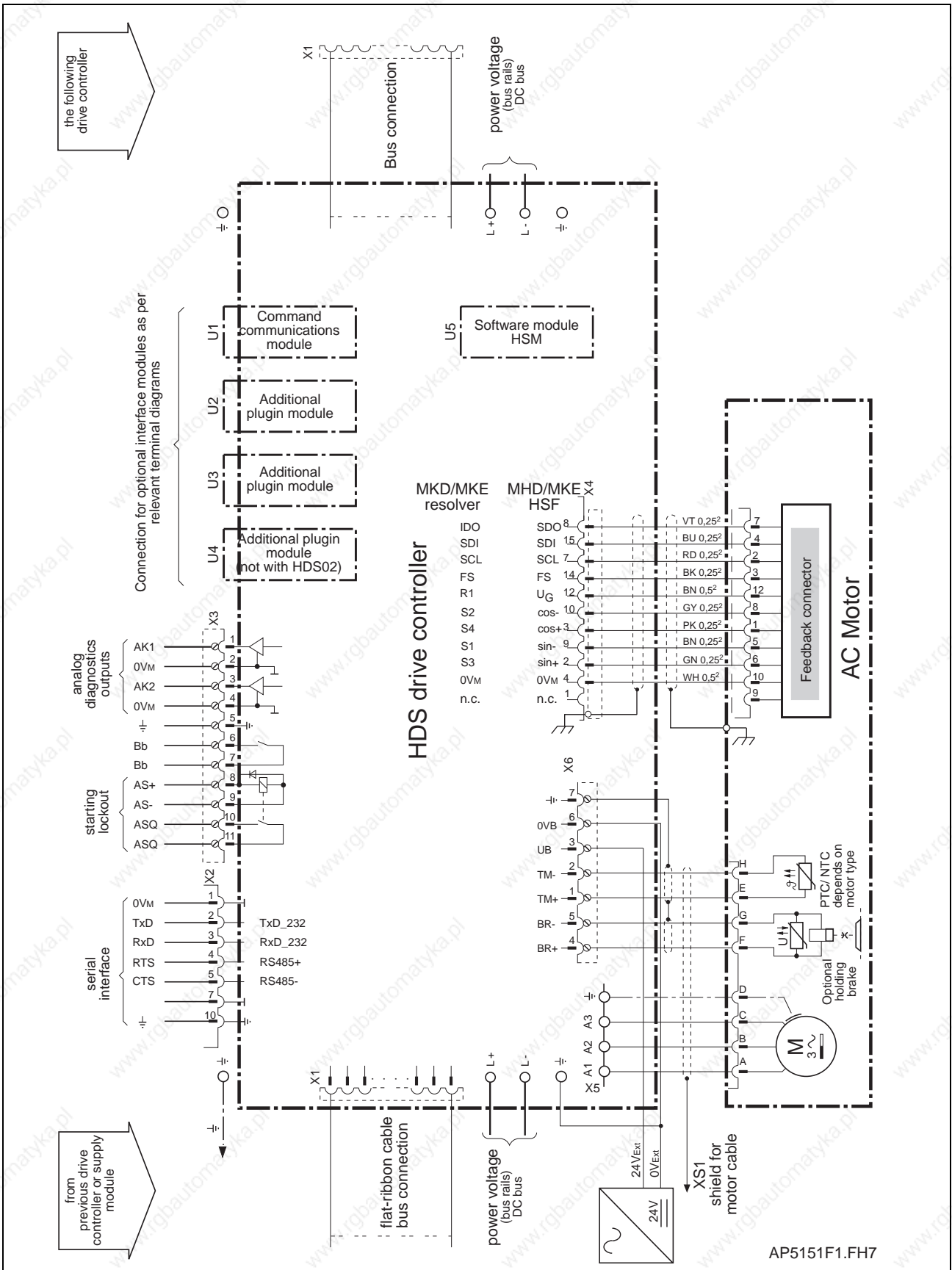

Fig. 6-2: Connections of a HDS drive controller labelled

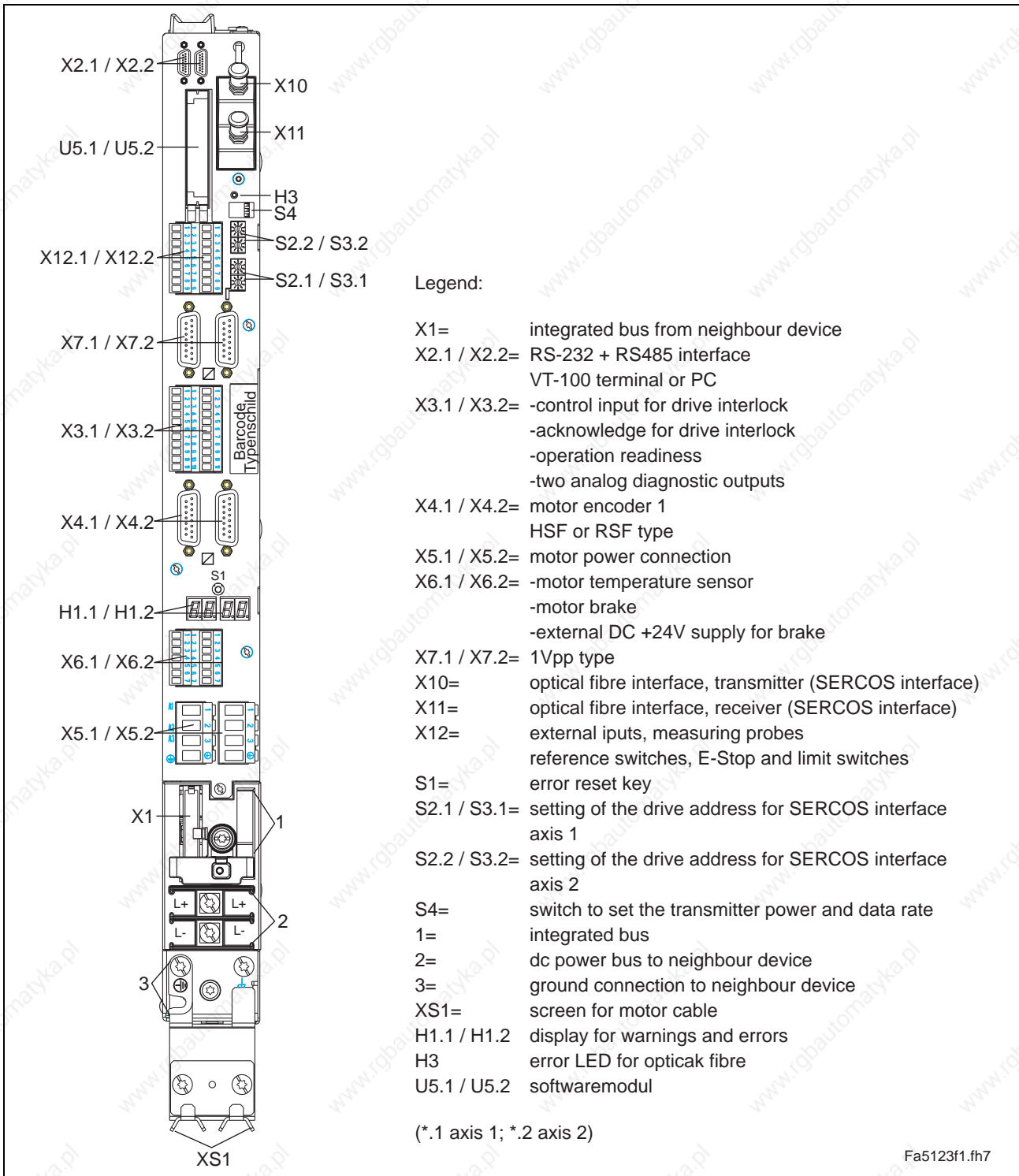

Fig. 6-3: Connections of a HDD drive controller labelled



Abb. 6-4: Connections of a HDD drive controller labelled



Abb. 6-5: Connections of a HDD drive controller labelled

X1, Connector for integrated bus connections from the neighboring unit

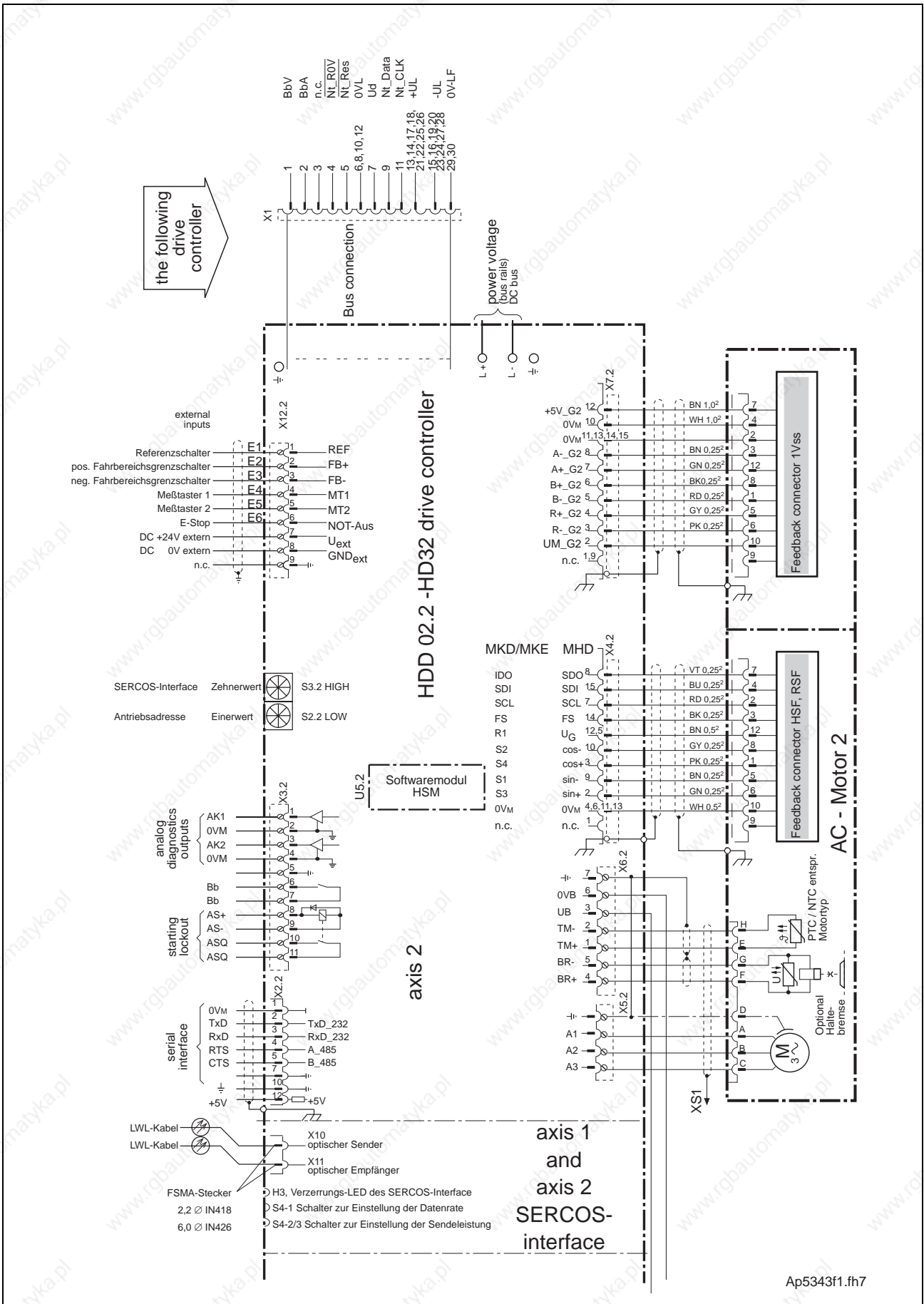
Technical data of connector

⑥ **Connector X1, bus connection**

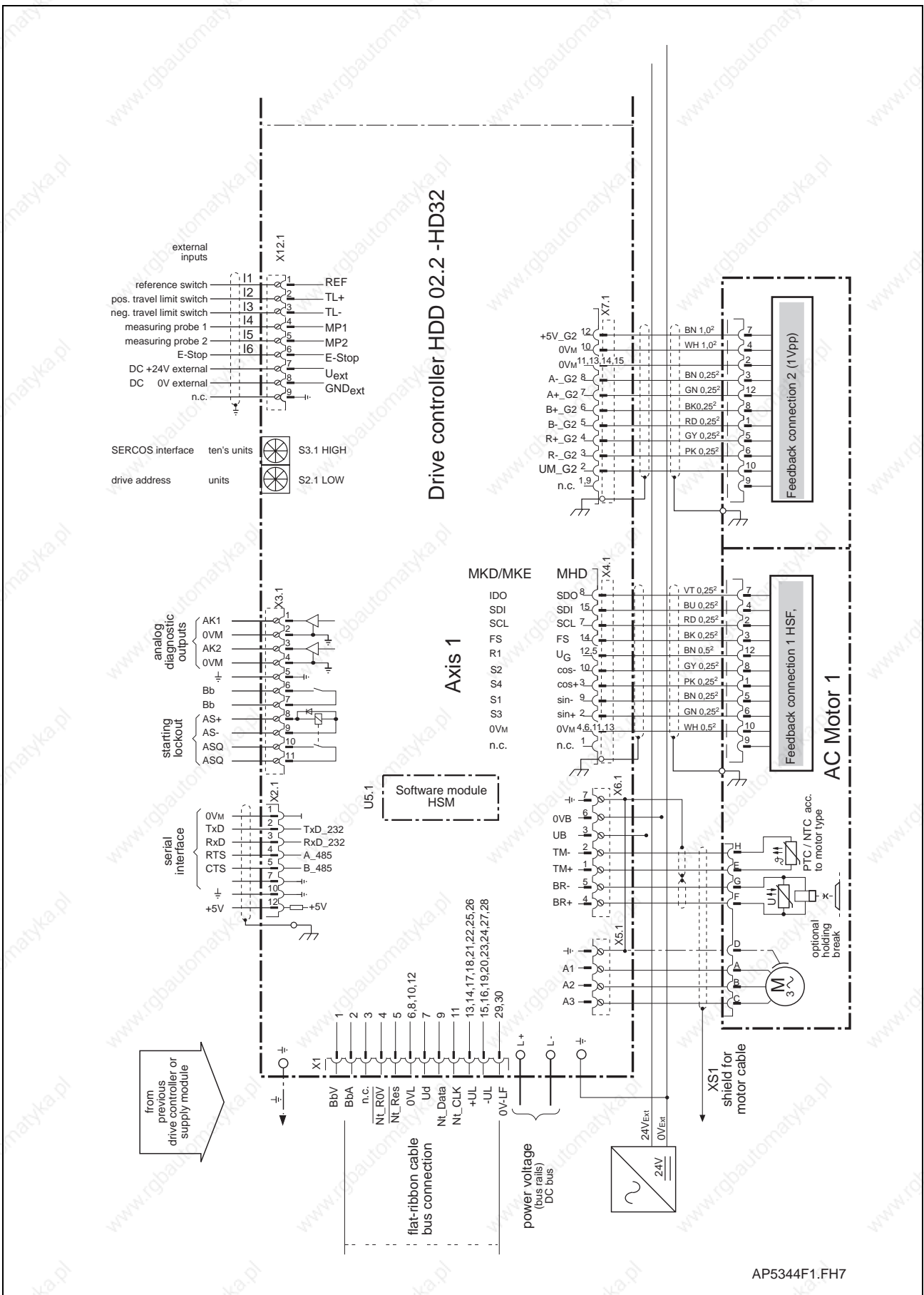
The control electronics of the drive controller receive their power via connector X1. The connection starts at the supply unit and runs to the drive controller with the help of the flat-ribbon cable integrated into the units. Maximum length here also equals one meter (if extensions are used)!

Illustration:

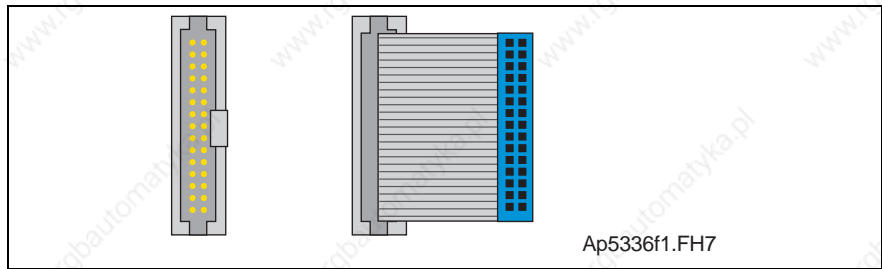

Fig. 6-6: Connector X1

Design

Type	No. of pins	Design
FBK connector	30	connector at the unit
FBK bushing	30	bushing at the FBK

Fig. 6-7: Design

Note: This is an internal connection between the supply unit and the drive controller.

X2, Serial interface

⑧ Connector X2, serial interface

Technical data of connector

This serial interface supports the communication of the controller with a PC with the help of suitable software (e.g., SERCTOP or DRIVETOP).

Note: Serial interfaces are generally used for programming, parameterization and diagnoses upon commissioning and during service. It can be operated either as RS 232 or RS 485.

Illustration:

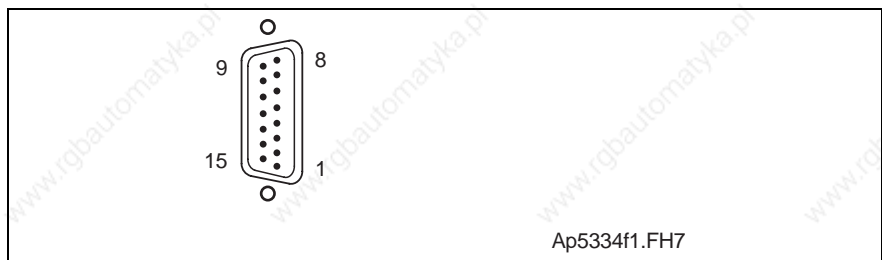

Fig. 6-8: Connector X2

Design:

Type	No. of pins	Design
D-SUB	15	bushings on unit

Fig. 6-9: Design

Connection cross section:

Cross section single wire [mm ²]	Cross section multi core wire [mm ²]	Cross section in AWG gauge no.
--	--	26 - 30

Fig. 6-10: Connection cross section

RS 232 interface

The RS 232 interface is used for programming, parameterization and diagnoses at start up and service.

It makes possible:

- a participant number of maximum 1
- a transmission length of up to 15 m
- transmission rates of 9600/19200 baud

Using an RS 232 interface only one drive at a time can be parameterized with the DriveTop start-up program.

Connection RS232:

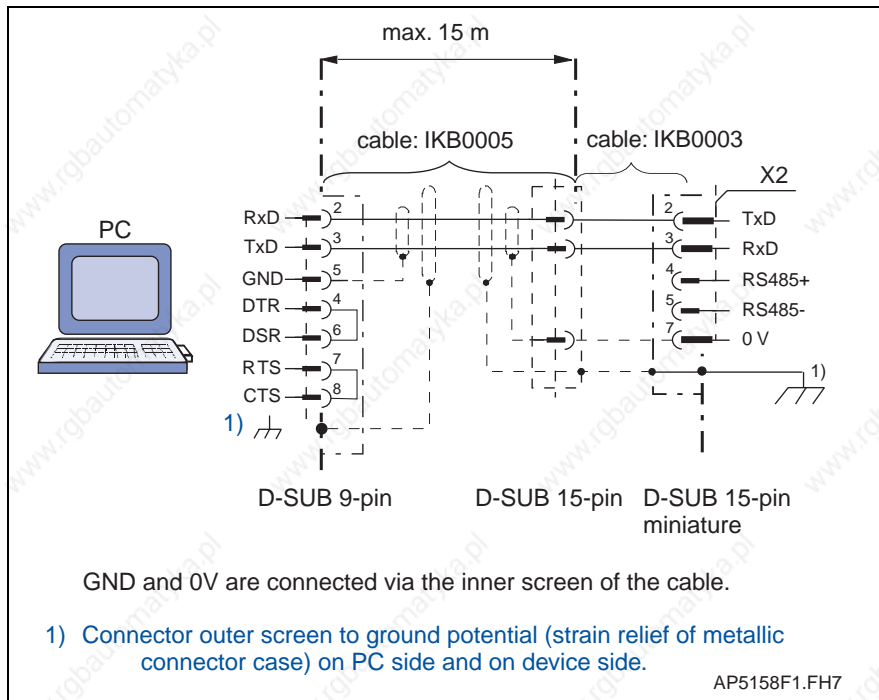

Fig. 6-11: Connecting a PC to the RS 232 interface on a DKC

RS 485 interface

The RS 485 interface is used for programming, parametrization and diagnoses at start up and service.

It makes possible:

- the implementation of a serial bus with up to 31 participants connected via a two-wire cable (half duplex mode).
- A transmission length of up to 500 m
- Transmission rates of 9600/19200 baud.
- The use of a centrally PC supported visualization unit.

Using an RS 485 makes possible the commissioning of several DKCs with DriveTop without changing the interface cables.

The following options for working with RS485 are available

- RS232/RS485 converter between PC and drives
- RS485 plug-in card in PC

Please contact your PC supplier to help find the appropriate solution for your application.

Installation notes for RS485 – cables

Note: Details are listed in "Electromagnetic compatibility (EMC) and control systems", DOK.-Type
DOK-GENEERL-EMV*****-PRXX-EN-P

Connector for RS485 interface

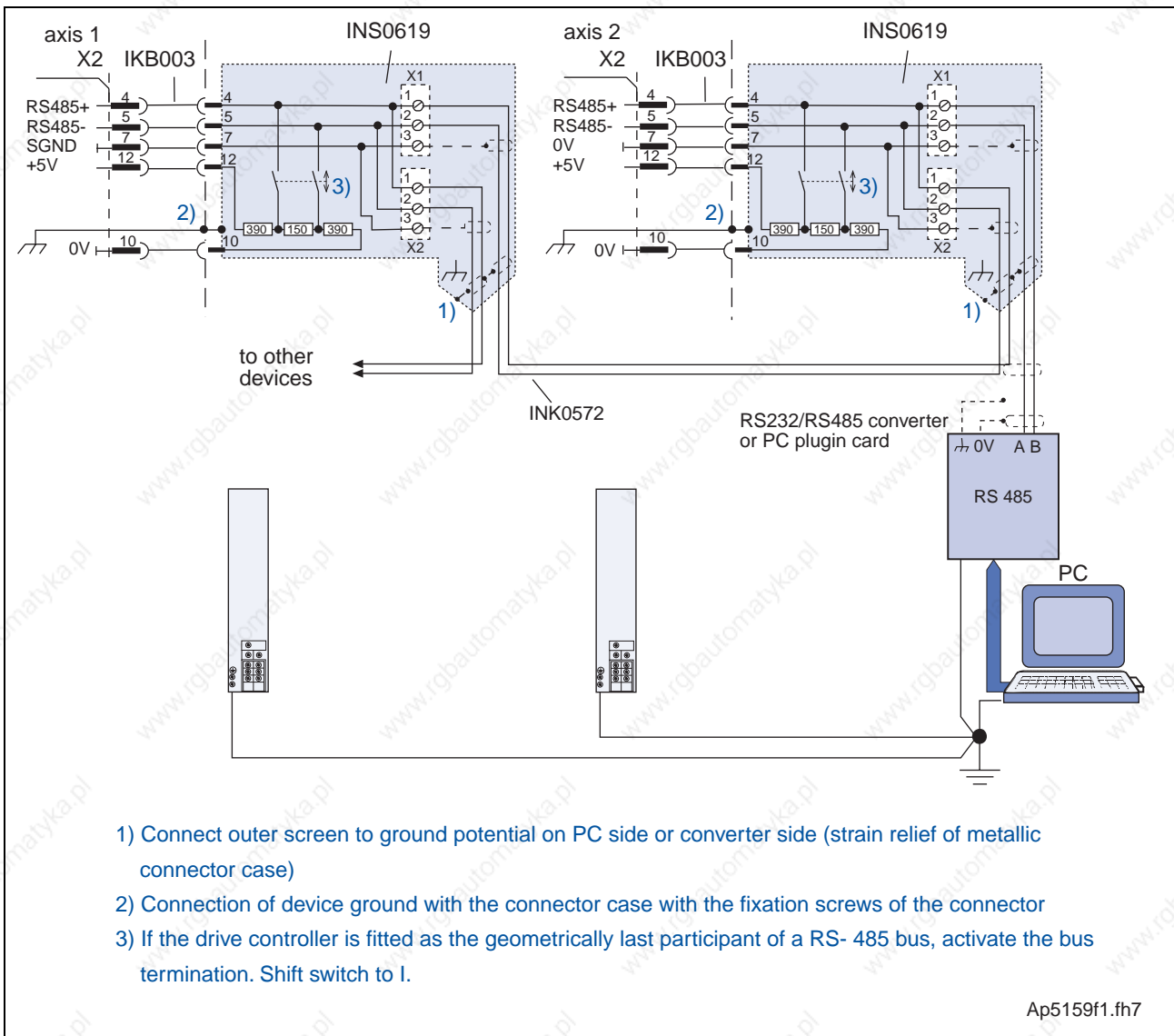

Fig. 6-12: Connection example of RS485 interface

X3 Analog outputs, ready to operate, starting lockout

Technical data of connector

Illustration:

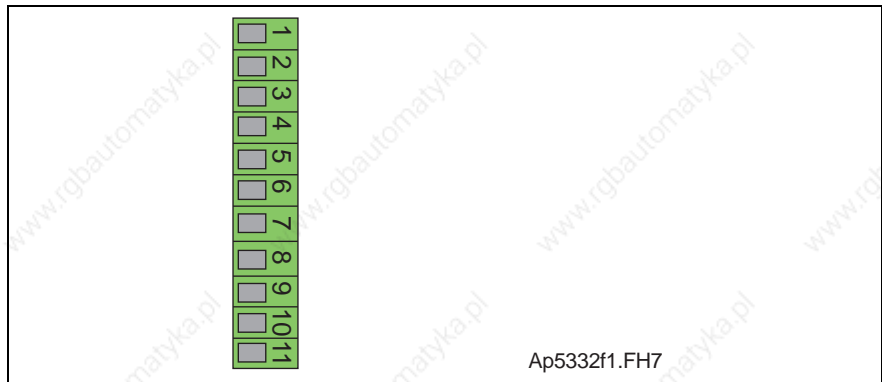

Fig. 6-13: Connector X3

Design:

Type	No. of pins	Design
screw-type terminal	11	pins at the unit

Fig. 6-14: Design

Connection cross section:

Cross section single wire [mm ²]	Cross section multi core wire [mm ²]	Cross section in AWG gauge no.
0,14 - 1,5	0,14 - 1,5	28 - 16

Fig. 6-15: Connection cross section

⑦ Connector X3, analog outputs, ready to operate, starting lockout

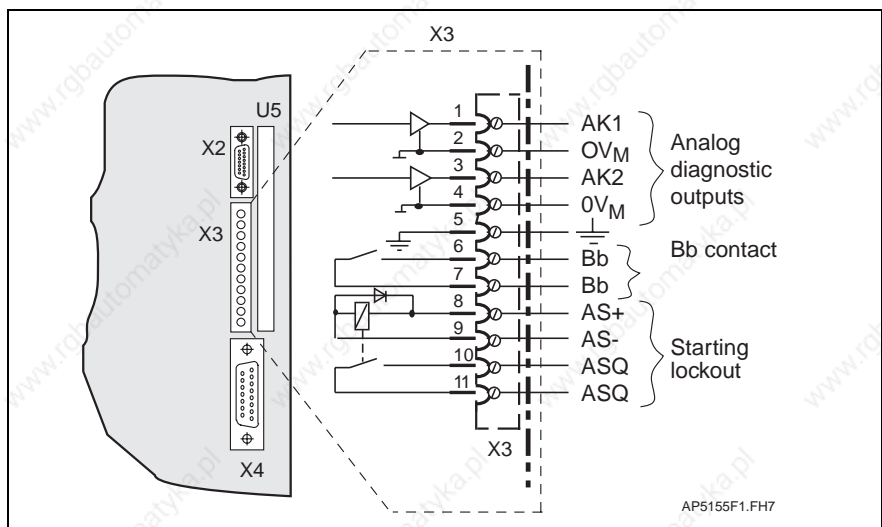

Fig. 6-16: Connector assignment - X3

Analog diagnostic outputs, AK1 AK2

Analog diagnostic outputs are outputs over which drive-internal variables can be generated for test purposes (e.g., with startups). For detailed information on analog diagnostic outputs, see documentation "DIAX04 Function Description".

Current load capacity: 4 mA

Output voltage: DC +/-10 V

Ready to operate contact Bb

Once the ready to operate contact "Bb" closes, then the drive controller is ready to receive power.

Contact "Bb" closes once power voltage is on and all monitoring functions have signalled they are operational.

Contact "Bb" can be evaluated, e.g., in the control system so that it can recognize, in the event a unit, in hardware terms, is defective, which drive controller in the drive package has failed.

Circuit load: DC 24 V, 1 A (maximum = continuous)

Minimum load of contact: 10 mA

Note: The direct connection of a mains contactor via contact Bb is only permissible if the ON current does not exceed 1A. Higher currents can cause the relay to fail. The use of varistors as protective circuits is not recommended as these age. This can, in turn, cause an early failure of the connected components and thus of the unit itself as well.

Starting lockout AS+, AS-, ASQ, ASQ

The starting lockout is a safety mechanism to secure against unintentional startups of the connected motor in the event an error occurs. It serves to securely switch off separate working areas within a machine or plant.

Note: A starting lockout does not bring moving axis to a standstill.

Supplementary information on starting lockouts is outlined in the description "Starting lockout function in DDS drive controllers" DOK-DIAX02-DDS*ANL*FKT-AWXX-EN-P.

AS+, AS-:

- control inputs for relay coils
- voltage: DC 20 30 V
- power: 1.5 W

ASQ, ASQ:

Potential-free feedback contact which acknowledges the actuating of the starting lockout to an external control.

Breaking capacity: DC 24 V, 1 A (maximum = continuous)

The actuation of the relay of the starting lockout in the drive controller is confirmed by the closing of the potential-free feedback contact (output ASQ - ASQ) to the external control.

To activate the starting lockout, apply a voltage of DC 20 to 30 volts between AS+, AS-.

X4, Motor feedback connector (encoder 1)

⑨ Connector X4, motor feedback

Technical data of connector



An HSF or RSF Rexroth Indramat motor feedback is connected at X4 in compliance with the terminal diagram of the motor implemented. If any other type of motor encoder is connected, then it is necessary to use an appropriate additional plug-in module.

Note: The same guidelines as apply to the power cable (see section 7.1 Dimensional sheet) also apply to the connection between drive controller and motor feedback.



CAUTION

The connectors X4.1/X4.2, feedback 1 (HSF, resolver) and the connectors X7.1/X7.2, feedback 2 (1 Vpp) may not be mistaken for each other!

Illustration:

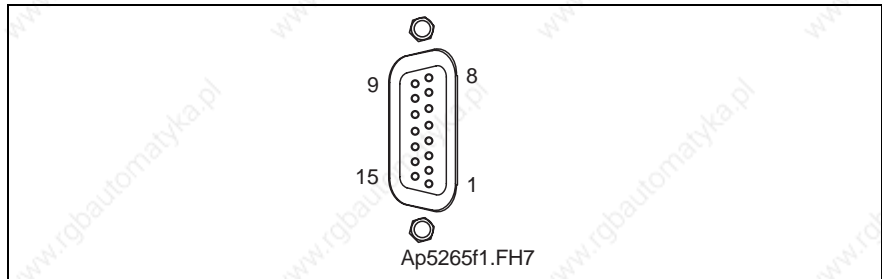

Fig. 6-17: Connector X4

Design:

Type	No. of pins	Design
D-SUB	15	bushing on unit

Fig. 6-18: Design

Connection cross section:

Cross section single wire [mm ²]	Cross section multi core wire [mm ²]	Cross section in AWG gauge no.
--	0.25-0.5	--

Fig. 6-19: Connection cross section

**Connection
Encoder 1:**

Encoder 1

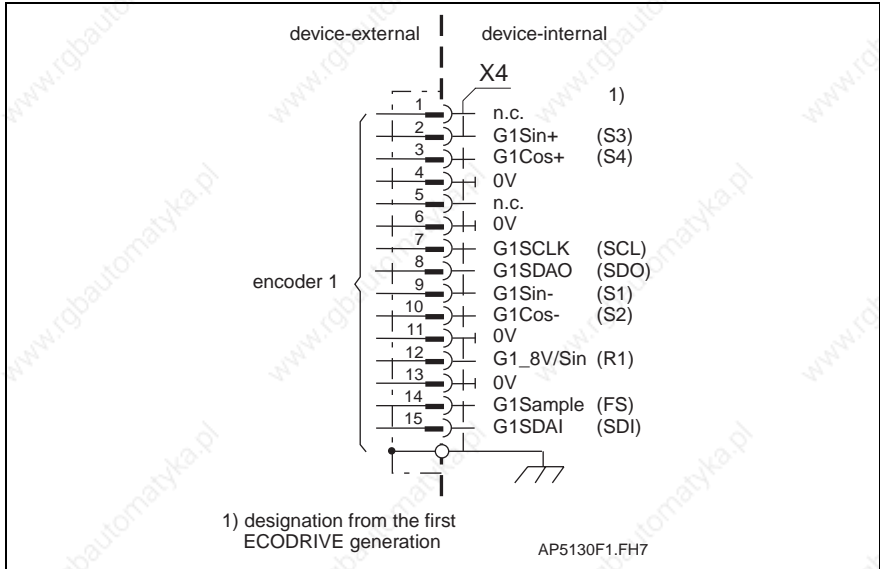

Fig. 6-20: Encoder 1

Note: If a standard Rexroth Indramat feedback cable is used, then the cable should exit the connector towards the top of the drive.

X5 Intermediate circuit, motor, and power connections

Technical data of connector

Illustration:

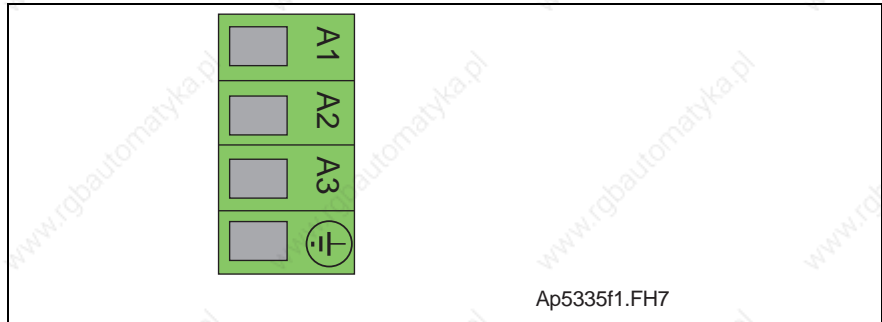

Fig. 6-21: Connector X5 HDD02, HDS02

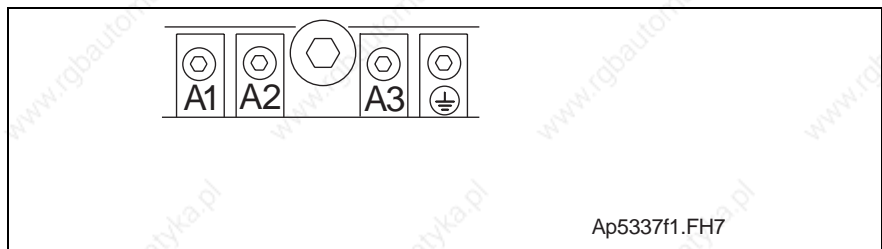

Fig. 6-22: Connector X5 HDS03, HDS04

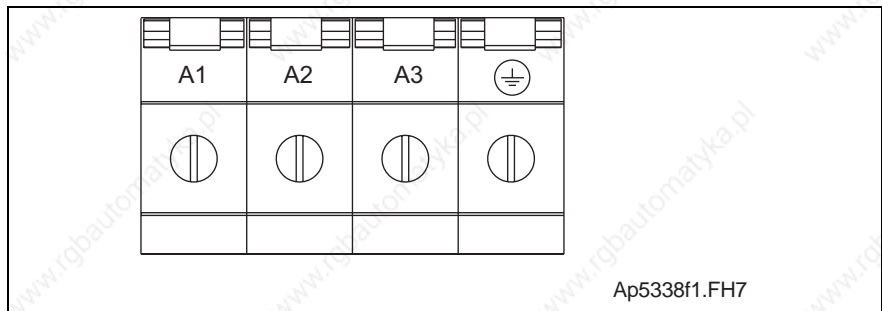

Fig. 6-23: Connector X5 HDS05

Design:

Type	No. of pins	Design
Screw-type terminal	4	pins at the unit

Fig. 6-24: Design

Connection cross section:

	Cross section single wire [mm ²]	Cross section multi core wire [mm ²]	Cross section in AWG gauge no.
HDD02, HDS02	0,2-4	0,2-4	24-10
HDS03	2,5-10	4-16	12-4
HDS04	2,5-16	2,5-35	12-2
HDS05	16-50	16-50	6-0

Fig. 6-25: Connection cross section: X5

Tightening torque:

	DC Bus	Motor connection
HDD02, HDS02	3 Nm	0,5 - 0,6 Nm
HDS03	3 Nm	2 Nm
HDS04	3 Nm	4 Nm
HDS05	3 Nm	6 Nm

Fig. 6-26: Tightening torques: X5

① **Ground connections to the supply module**

HDD and HDS drive controllers are equipped with two ground connections (grounding system) to the supply module:

- back wall of the unit and the mounting rails as well as
- grounding clips in the front of the unit (see illustration)

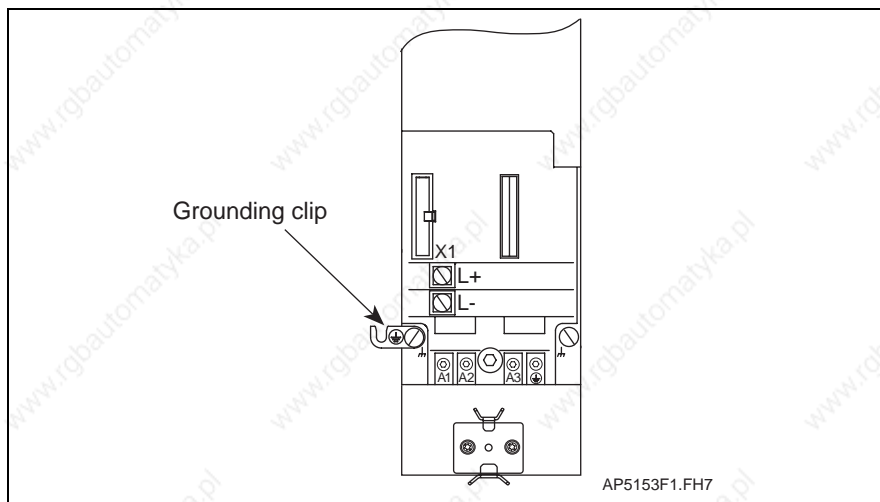

Fig. 6-27: Ground connections - controller

Also see section 11.1 Mounting the drive controller" for supplementary information.

②+③+④ **Motor power cable connection**

Rexroth Indramat motor power cables should be used to connect drive controller and motor.

The Rexroth Indramat motor power cable contains:

- three supply wires for the motor power connection
- a wire for the grounded conductor connection
- a separately shielded pair of wires for the motor temperature monitor
- a separately shielded pair of wires for the motor holding brake
- a complete shield mounted to shield attachment

The motor power cable is available as a ready-made cable from Rexroth Indramat. The cable can also be made of four twisted individual supply wires (3 phases, 1 grounded conductor) with a separately conducted, shielded supply wire for temperature monitoring and the brake connection.

For supplementary technical data on connections and diameters, see the relevant motor description.

Line length Maximum cable lengths equals 75 meters if Rexroth Indramat cables are used (see also section 7.1 Dimensional sheet).

⑤ **DC bus voltage connection** Adjacent drive controllers are generally connected via the connection wires (supplied with the drive).

If a connection with the connection wires should not be possible, then establish the connection using twisted supply lines that are as short as possible (maximum length equals one meter, minimum cross section 25mm²).

⑩ **Connector XS1, shield attachment of motor cable**

The entire shield of the motor cable is mounted to shield attachment XS1 using the enclosed clamp fitting. It is matched to the diameter of the cable by simply selecting the relevant clamp base on the mounting panel. The cable output direction can be either horizontal or vertical and is achieved by adjusting the mounting panel.

X6 Holding brake, motor temperature monitoring

Technical data of connector

Illustration:

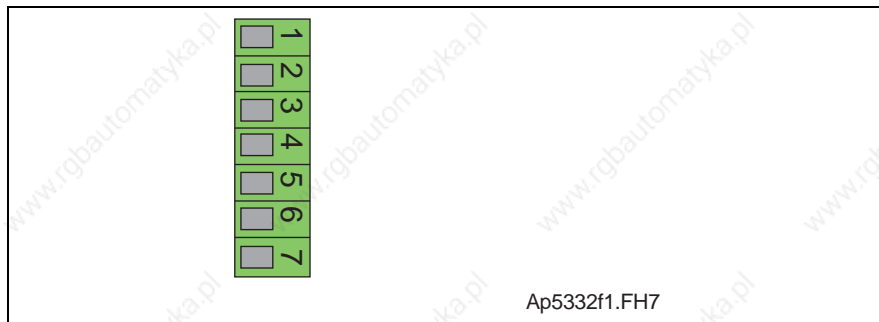

Fig. 6-28: Connector X6

Design:

Type	No. of pins	Design
screw-type terminal	7	pins at the unit

Fig. 6-29: Design

Connection cross section:

Cross section single wire [mm ²]	Cross section multi core wire [mm ²]	Cross section in AWG gauge no.
0,14 - 1,5	0,14 - 1,5	28 - 16

Fig. 6-30: Connection cross section



DANGER

Dangerous movements! Persons at risk by falling or dropping axles!

- ⇒ The standard motor holding brake as delivered, or any external motor holding brake activated by the drive controller by itself does not provide adequate personal protection!
- ⇒ Personal protection must be ensured by primary failsafe measures:
The dangerous zone must be blocked off by a safety fence or safety grates.
After the motor is switched off, vertical axes must be additionally protected from falling or dropping, e.g. as follows:
 - by mechanically locking the vertical axis,
 - by an external braking, catching or clamping unit,
 - by adequately counterbalancing the weight of the load.

④ Connector X6, holding brake, for temperature monitor

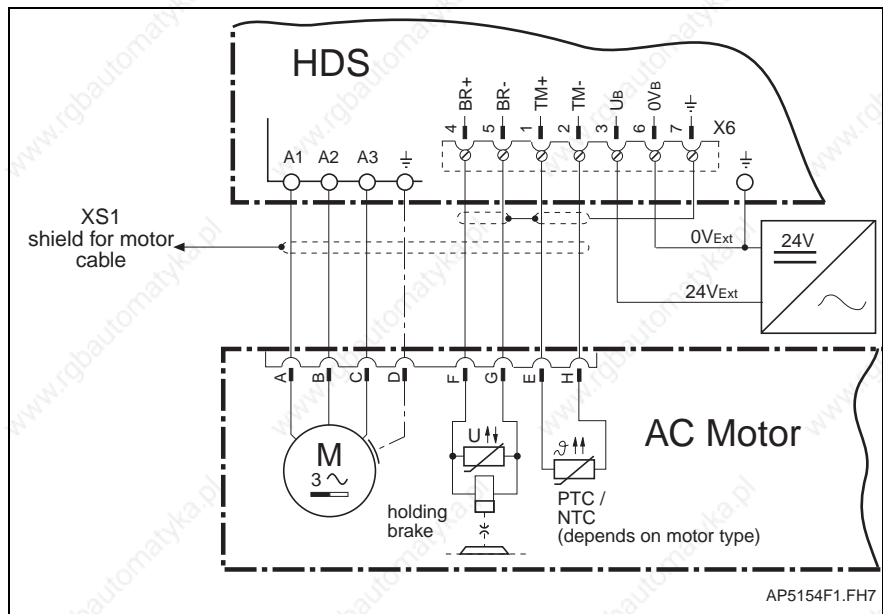

Fig. 6-31: Motor cable, holding brake and temperature monitor connection



ATTENTION

If a motor holding brake is used, then it is necessary to connect an external 24V three-phase voltage source. The 0V_{Ext} (= 0V_B) must be galvanically connected with the reference potential or housing of the drive controllers!

Maximum permissible brake current: 2A

If the brake currents exceed this value, the motor holding brake must be actuated via an external switching device

Current consumption of the holding brake is listed in the Project Planning Manual of AC motors.

The AC motor holding brake is not a dynamic brake. It wears down after about 20,000 motor revolutions against the closed brake disc.

Note:

To release a holding brake in the MHD/MKD servo motors, an external +24V DC / +10 % must be supplied to the drive. The voltage to release the brake is applied to X6/3 (+24V) and X6/6 (0V). It must be ensured that the brake will release even if longer motor power cables are used (voltage drop with long motor power cables can be compensated by increasing supply voltage (up to DC +26.5V) and/or with a regulated voltage supply at X6/3 and X6/6).

Control of the motor holding brake

The drive controller controls the holding brake.

X7.1/X7.2 Motor feedback connector (encoder 2)

Technical data of the connecting terminal

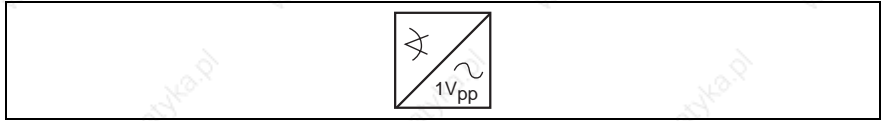

Note: The connector X7.1 / X7.2 is present in the **HDD** drive controller **with fixed configuration** only.

Measuring system

The "high-resolution positioning interface" is provided for taking over of sinusoidal signals for detecting the position of an external measuring system which is directly attached to the moving machine element.

The high-resolution positioning interface evaluates measuring systems with

- sinusoidal **voltage** signals (feedback 2 (1 Vpp)).



Abb. 6-32: Connector X7



CAUTION

The connectors X7.1/X7.2, feedback 2 (1 Vpp) and the connectors X4.1/X4.2, feedback 1 (HSF, resolver) may not be mistaken for each other!

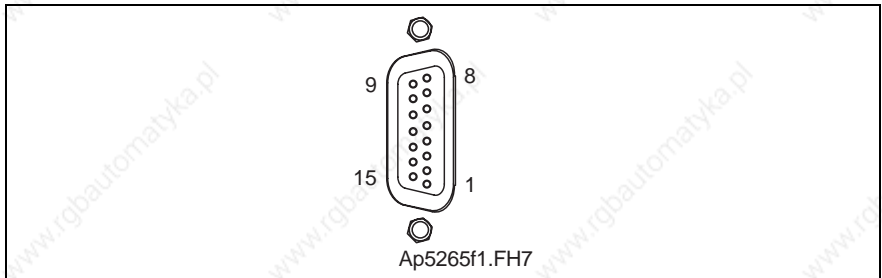
For delivery the second encoder (connector X7.1/7.2) is covered by a cap.

Connection diagram for measuring systems with voltage signals

Connection diagram

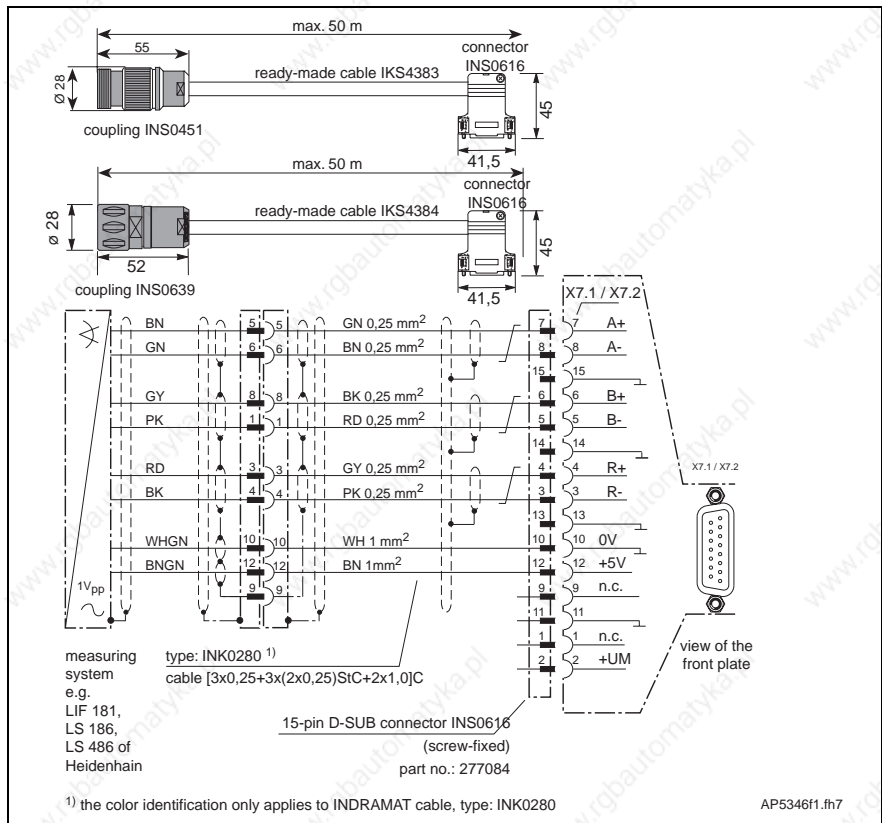

Fig. 6-33: Connection diagram for measuring systems with voltage signals

Signal assignment of measuring systems with voltage signals

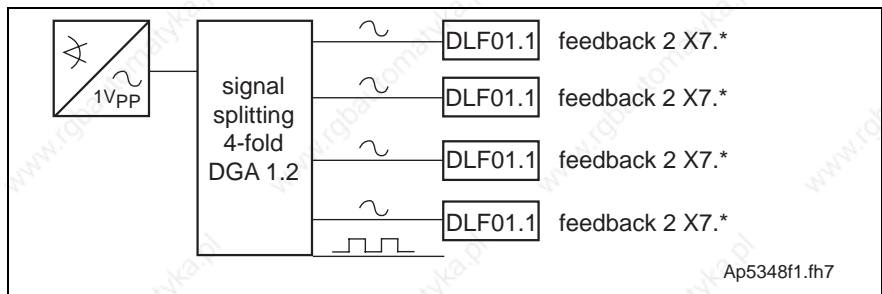

Fig. 6-34: Signal assignment of measuring systems with voltage signals

Also see the encoder branching DGA01.2 in the DIAX04 project plan, plug-in modules for digital intelligent drives.

Connection of measuring systems with current signals

Using the power driver DGV01.1, measuring systems can also be operated with current signals.

Also see the power driver DGV01.1 in the DIAX04 project plan, plug-in modules for digital intelligent drives.

Supply voltage for external measuring system

Output voltage X7.1 / X7.2: DC +5 V (±5%)
 max. load of the output X7.1 / X7.2: 150 mA

Signal shape	approximately sinusoidal signals.		
Resolution	The resolution of the signal period supplied by the measuring system is 2048-fold.		
Voltage signals	Signal voltage:	A, B, R 1	V_{SS}
	max. frequency for meas. system signals:	A, B 500	kHz
	max. frequency for reference signal:	R 15	kHz

Signal input circuit

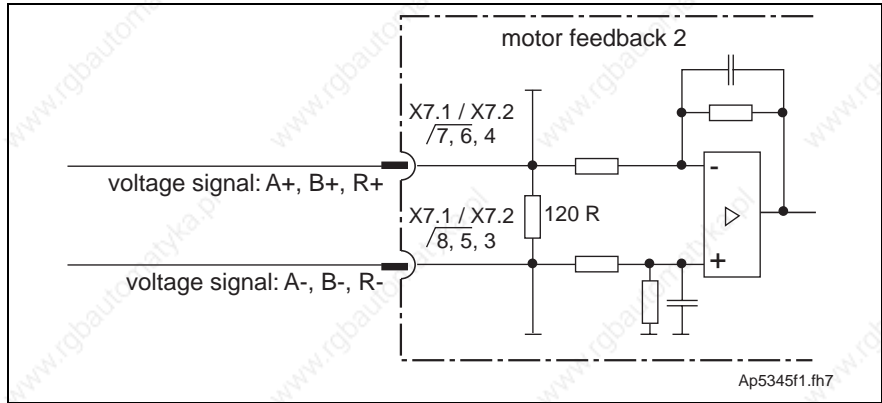

Fig. 6-35: Signal input circuit

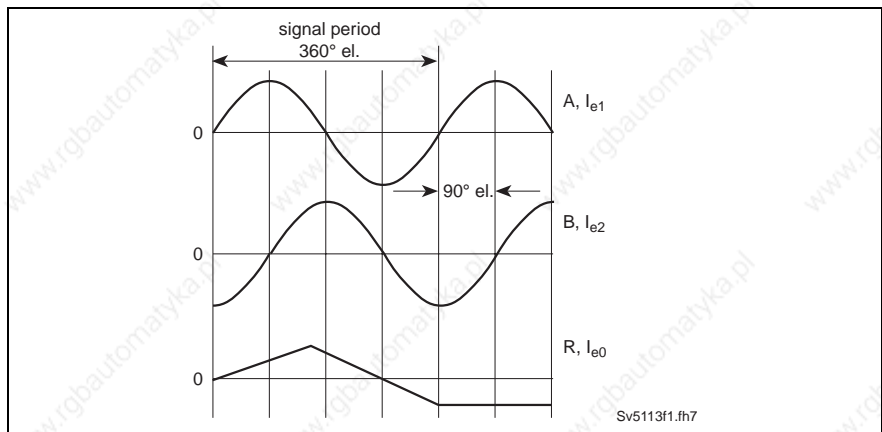

Fig. 6-36: Block diagram of the signal courses

X10/X11: SERCOS interface (HDD)

Technical data of the terminal connector

Note: The connector X10 / X11 is present in the **HDD** drive controller with **fixed configuration** only.

The “SERCOS interface” permits operation of the digital drives with SERCOS-interface-compatible control units via optical fibers. The optical connection (X10 / X11) complies with the requirements of the SERCOS interface specification IEC/EN 61491.

Excerpt from the SERCOS interface: specification of the optical interface:

	Description	Abbreviation	Unit	Low transmitter power	High transmitter power
Transmitter data Tx	max. transmitter power with optical low level	P_{SmaxL}	dBm/ μ W	-31.2/0.75	-28.2/1.5
	min. transmitter power with optical high level	P_{SminH}	dBm/ μ W	-10.5/90	-7.5/180
	max. transmitter power with optical high level	P_{SmaxH}	dBm/ μ W	-5.5/280	0/1000
	wavelength of the transmitter diode: peak wavelength spectral bandwidth	λ_p λ_p	nm nm	640...675 nm (0 °C..55 °C) - 30 nm (25 °C)	
Receiver data Rx	max. input power for optical low level	P_{EmaxL}	dBm/ μ W	-31.2/0.75	
	min. input power for optical high level	P_{EminH}	dBm/ μ W	-20/10	
	max. input power for optical high level	P_{EmaxH}	dBm/ μ W	-5/320	
	max. attenuation of the transmission path	$P_{SminH} \dots P_{EminH}$	dB	9.5	12.5

Fig. 6-37: Excerpt from IEC/EN 61491

Setting of the transmitter power

Switch position S4			Transmitter power with optical high level	
Stage	Switch S4 / 2	Switch S4 / 3	in dBm	In μ W
1	OFF	OFF	-7	200
2	ON	OFF	-4.5	350
3	OFF	ON	-1	800
4	ON	ON	0	1000

Fig. 6-38: Setting of the transmitter power

Upon delivery, a transmitter power with optical high level of -4.5 dBm is set.

Data rate The data rate can be selected using the switch S4/1 on the printed circuit board.

Switch position S4/1	Data rate in Mbauds
OFF	2
ON	4

Fig. 6-39: Data rate

Upon delivery, a data rate of 2 Mbauds is set.

The optical receiver circuit meets the requirements of the SERCOS interface specification (IEC/EN 61491).

In stage 1, the optical transmitter circuit corresponds to the low transmitter power and in stage 2 to the high transmitter power, thus meeting the requirements of the SERCOS interface specification (IEC/EN 61491).

X12.1/X12.2 External inputs (HDD)

Technical data of the connecting terminal

Note: The connectors X12.1 / X12.2 is present in the **HDD** drive controller **with fixed configuration** only.



Abb. 6-40: Connector X12

Inputs for the evaluation of reference switches, travel limit switches, measuring probes, and one E-stop input.

Voltage level

Description	Unit	Min.	Type/value	Max.
External voltage supply +U _{ext}	V	18	24	32
Current consumption of +U _{ext}	mA			100
Inputs U _{High}	V	16	24	32
E1...E6 U _{Low}	V	0		5.5

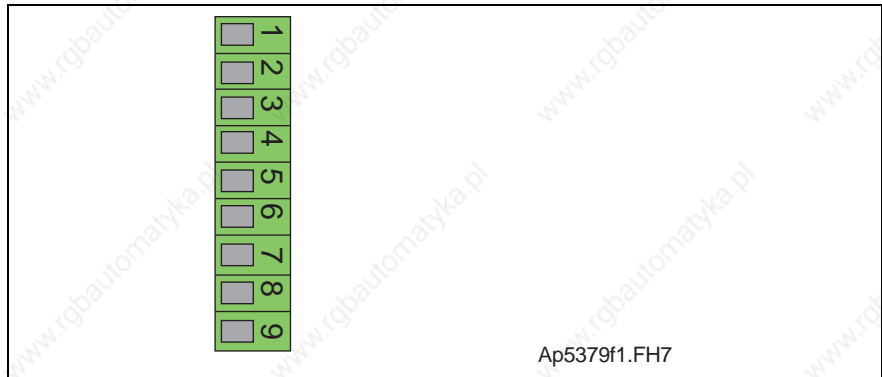
Fig. 6-41: Voltage level of DSS02.1M

Block diagram of the digital input circuit

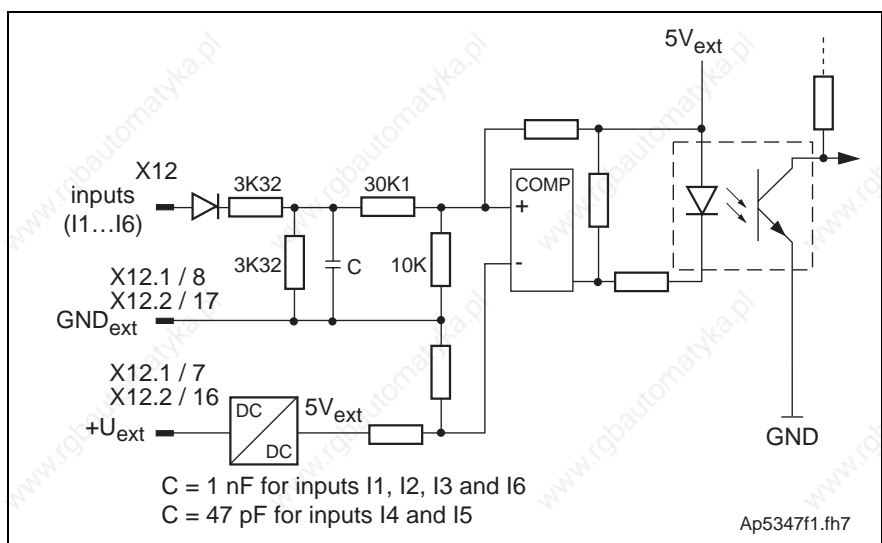

Fig. 6-42: Block diagram of the digital input circuit

Notes

7 Planning the design of the control cabinet

Note: When designing the control cabinet, the valid safety regulations with regard to shock-hazard protection (see e.g. EN 60204 / DIN VDE 0113, Part 1, for industrial equipment) must be observed.

7.1 Dimensional sheet

The mounting rail with type designation SUP-M01-HD (Part number: 271274) should be used to fasten the drive controller into the control cabinet. It is only available in a length of 750 mm and must be shortened as needed at delivery.

The mounting rails are screwed onto the mounting panel. Screwing it into place using every other slot is sufficient to fasten it.



Unit can be damaged as a result of incorrect mounting orientation!

Danger of overheating.

⇒ Operate units in the mounting orientations indicated only.

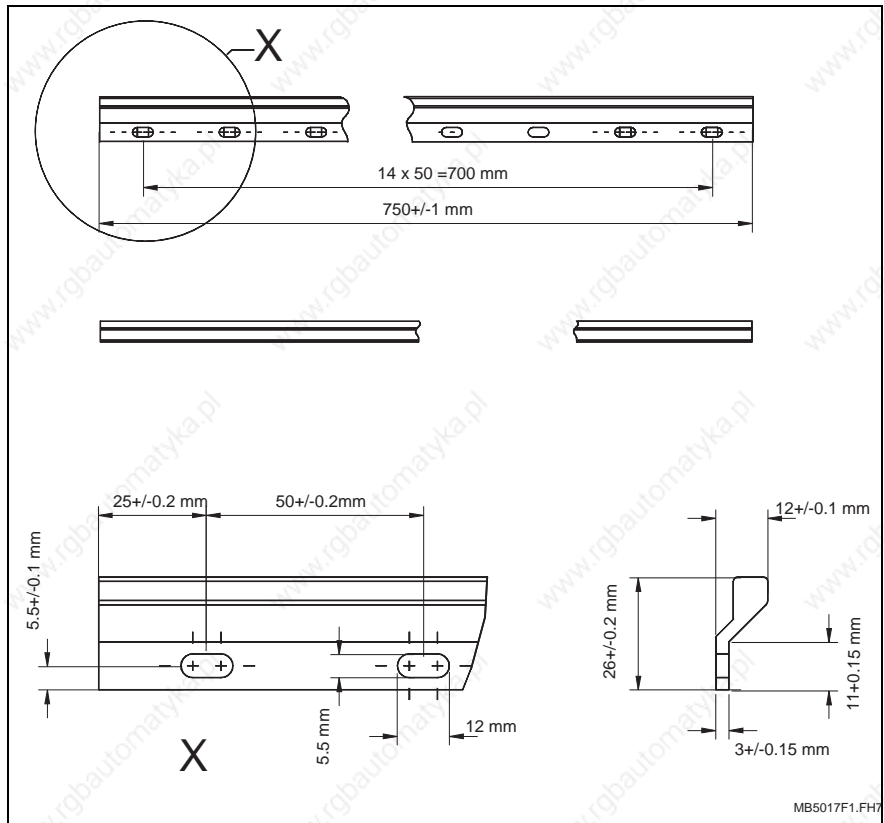

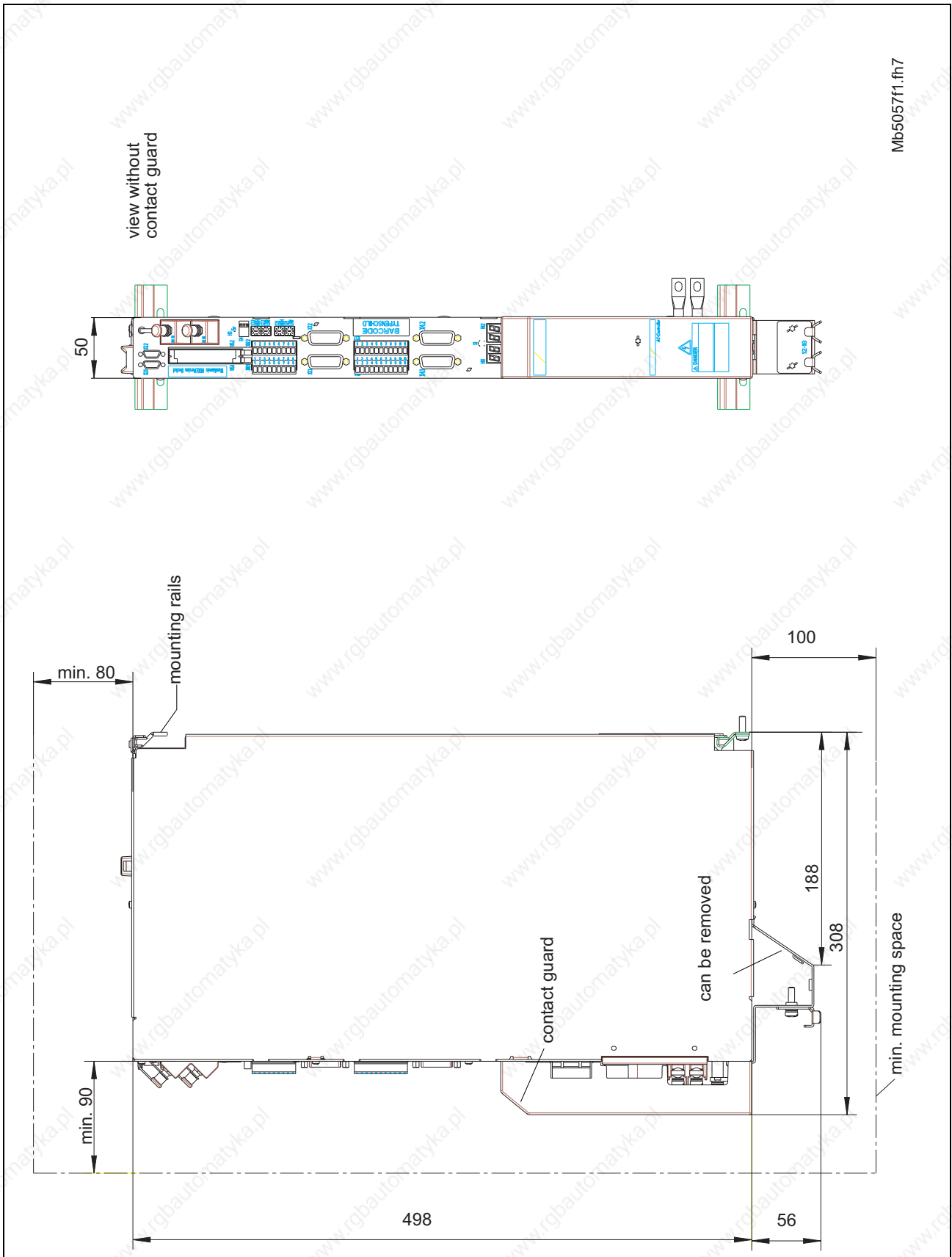

Fig. 7-2: Dimensional sheet - HDD02.2

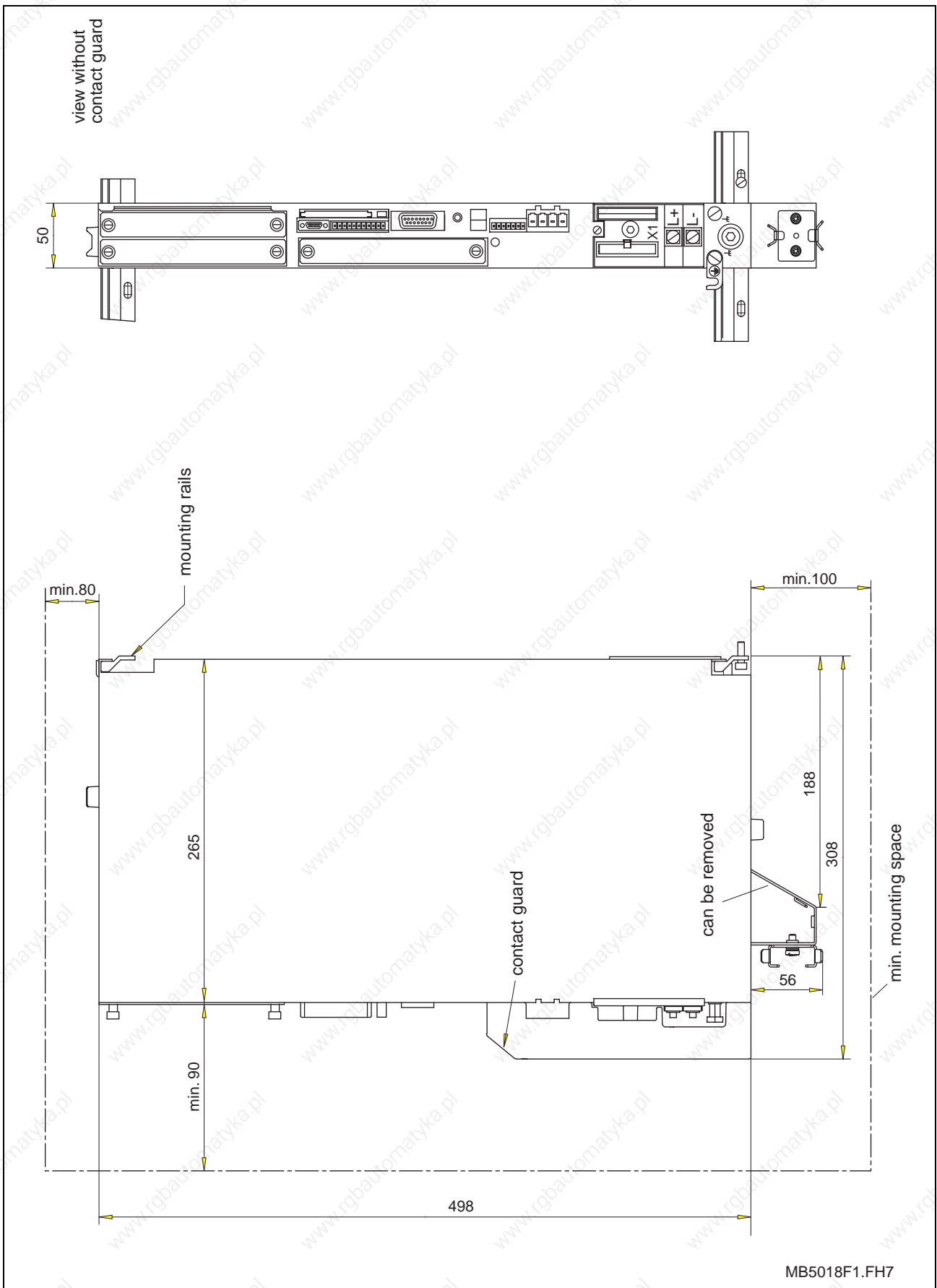

Fig. 7-3: Dimensional sheet - HDS02.2

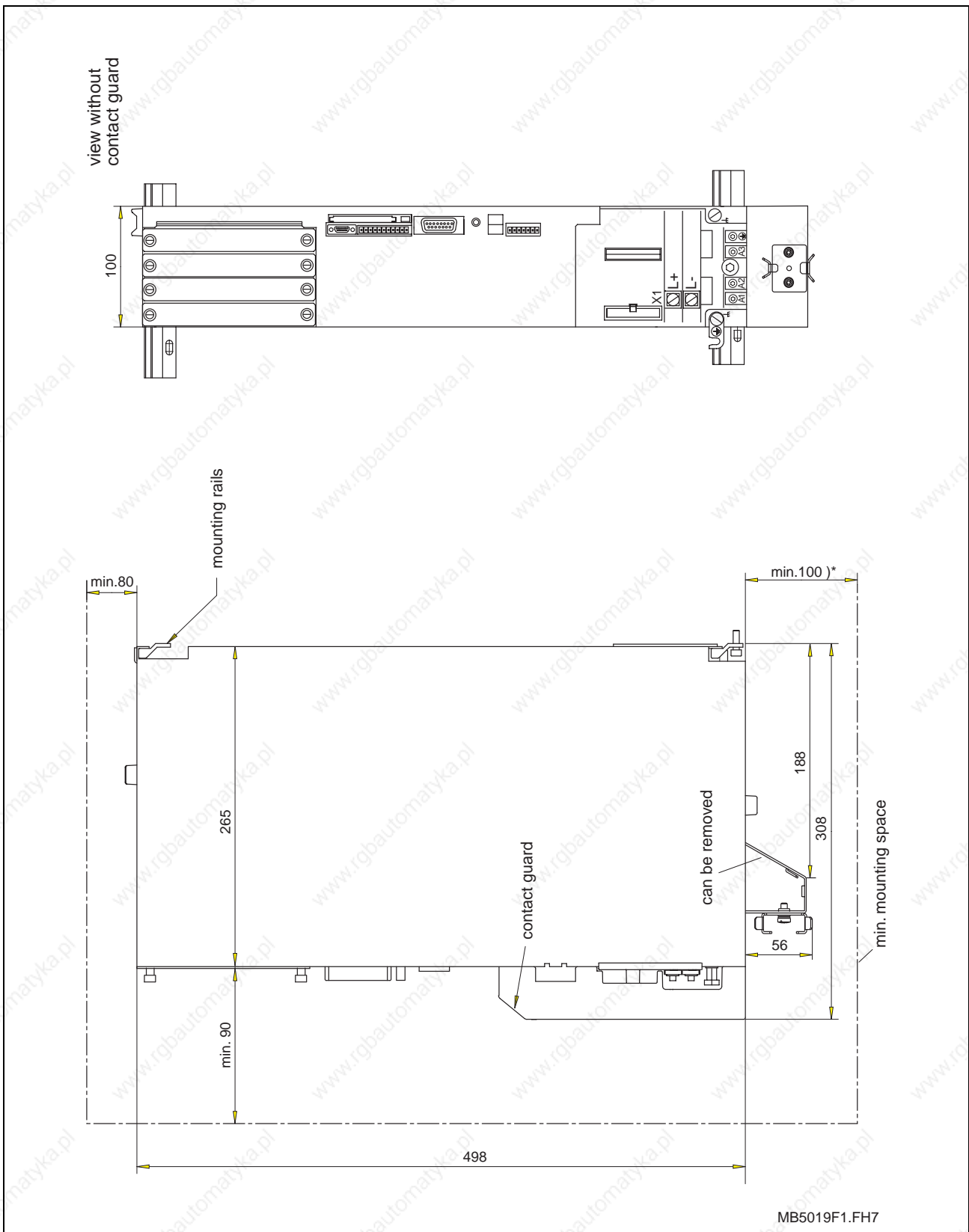

Fig. 7-4: Dimensional sheet - HDS03.2

*) A minimum clearance of 100 mm is required below the unit. In addition, the mounting clearance depends on the bending radius of the motor power cable.

See also: DOK-CONNEX-CABLE*xxxxx-Auxx-xx-P

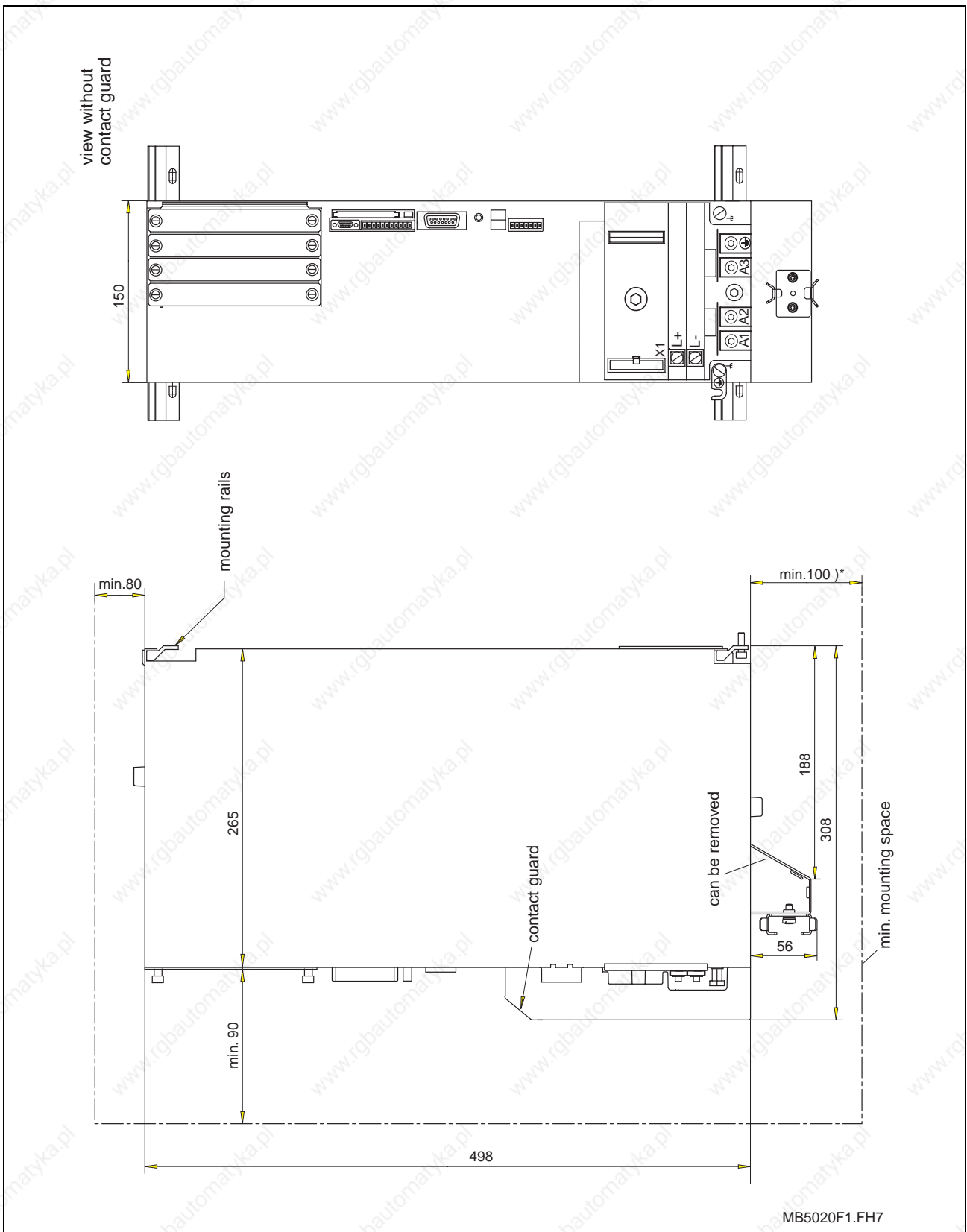

Fig. 7-5: Dimensional sheet - HDS04.2

*) A minimum clearance of 100 mm is required below the unit. In addition, the mounting clearance depends on the bending radius of the motor power cable.

See also: DOK-CONNEX-CABLE*xxxxx-Auxx-xx-P

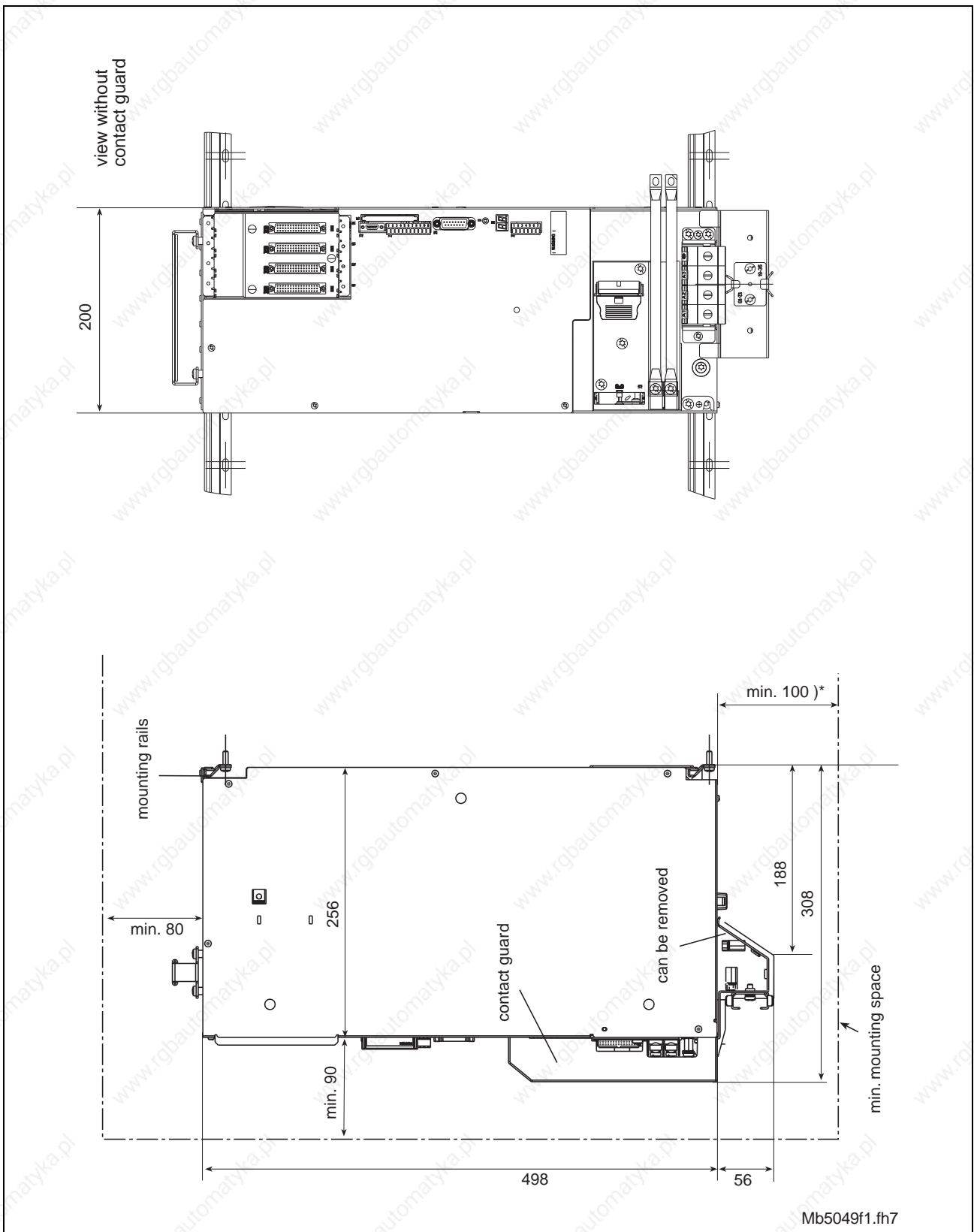

Fig. 7-6: Dimensional sheet - HDS05.2

*) A minimum clearance of 100 mm is required below the unit. In addition, the mounting clearance depends on the bending radius of the motor power cable.

See also: DOK-CONNEX-CABLE*xxxxx-Auxx-xx-P

7.2 Calculation of the drive controller losses

The power loss of a drive system radiated to the control cabinet is calculated from the sum of the losses of the supply unit, the losses of the series switching device, and the losses of each drive controller.

Please observe the documentation "DOK-POWER*-HVE+HVR**G2-ANW2-EN-P" when determining the losses of the supply unit and those of the series switching devices.

The power loss of a drive controller is composed of the losses for the control unit, the configuration-related losses, the basic losses of the power section, and the current-related losses of the power section.

The power loss of the control unit and configuration-related losses are determined as specified in chapter 4.8 Technical data - an overview.

The power loss of the power section is calculated using the mean continuous current of the controller on the basis of the following diagrams.

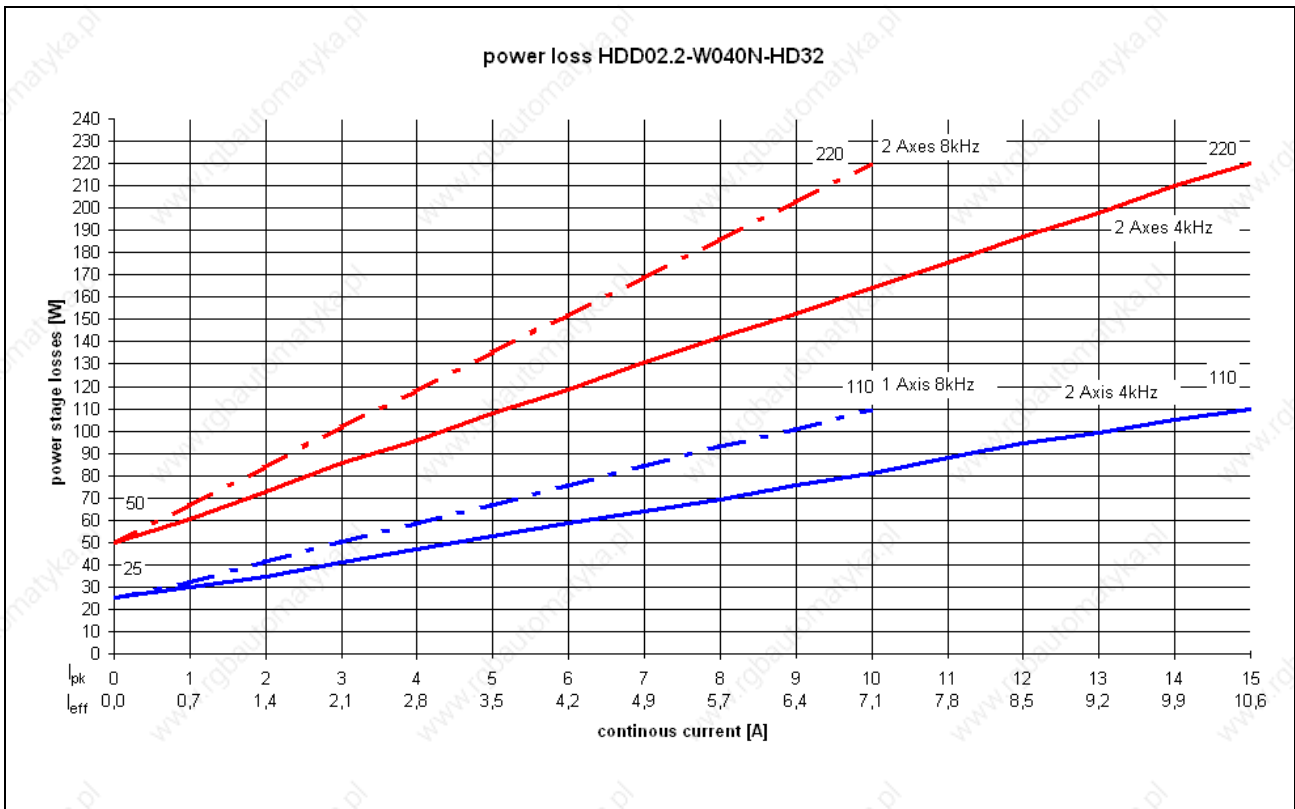

Fig. 7-1: Power loss HDD02.2-W040N-HD32

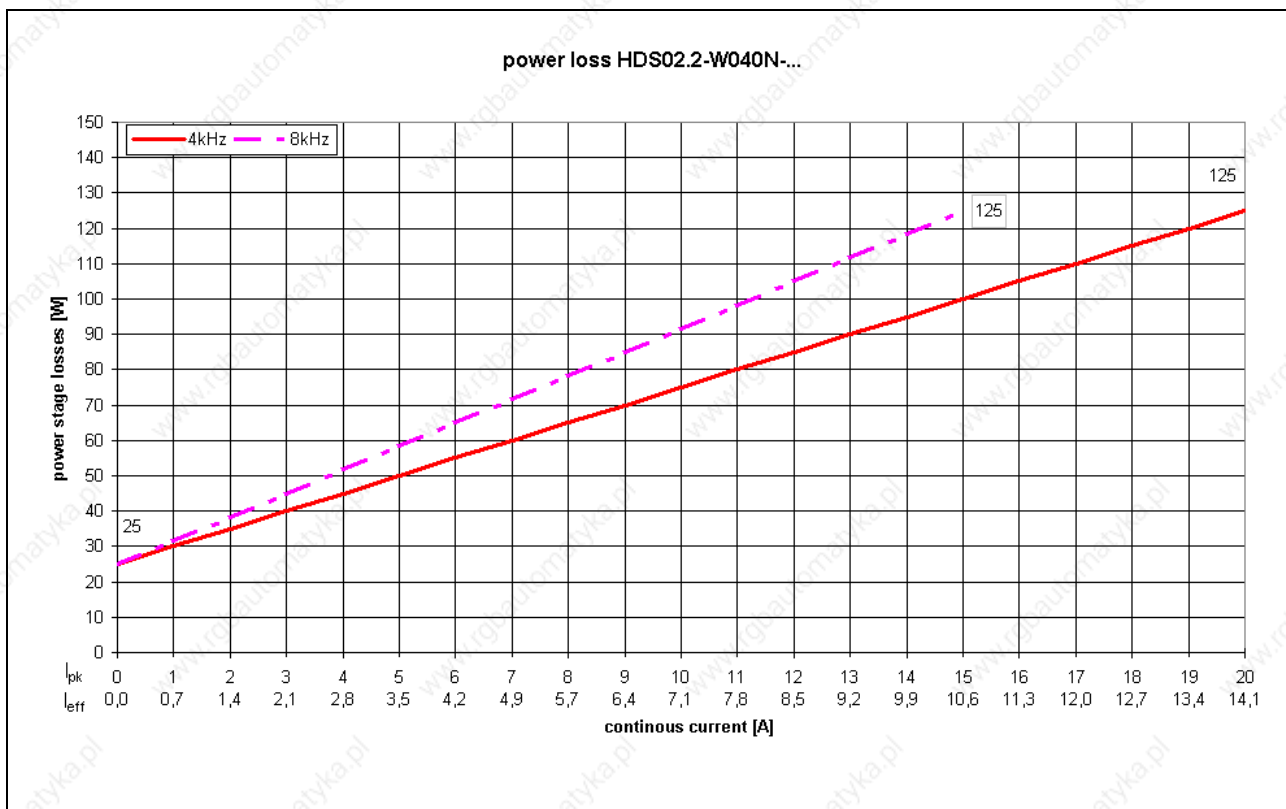

Fig. 7-2: Power loss HDS02.2W040N-

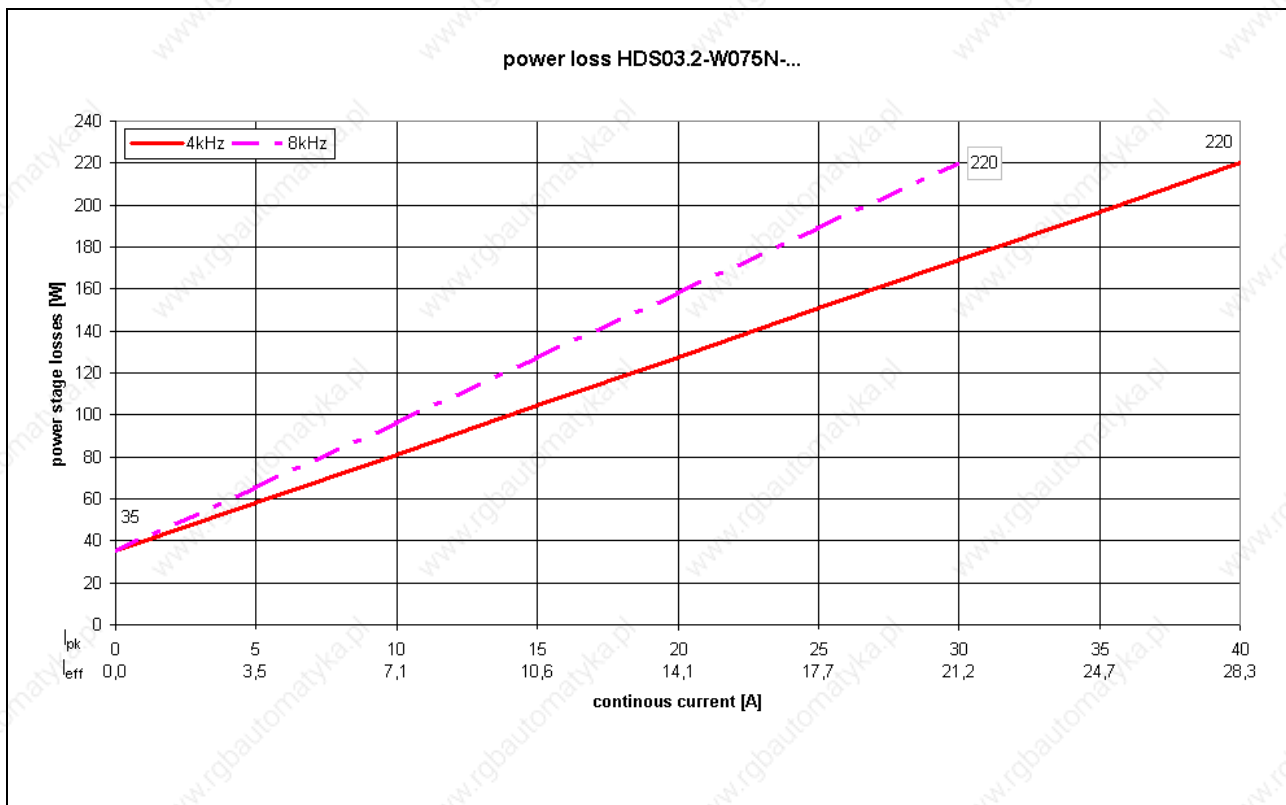

Fig. 7-3: Power loss HDS03.2W075N-



Fig. 7-4: Power loss HDS03.2W0100N-

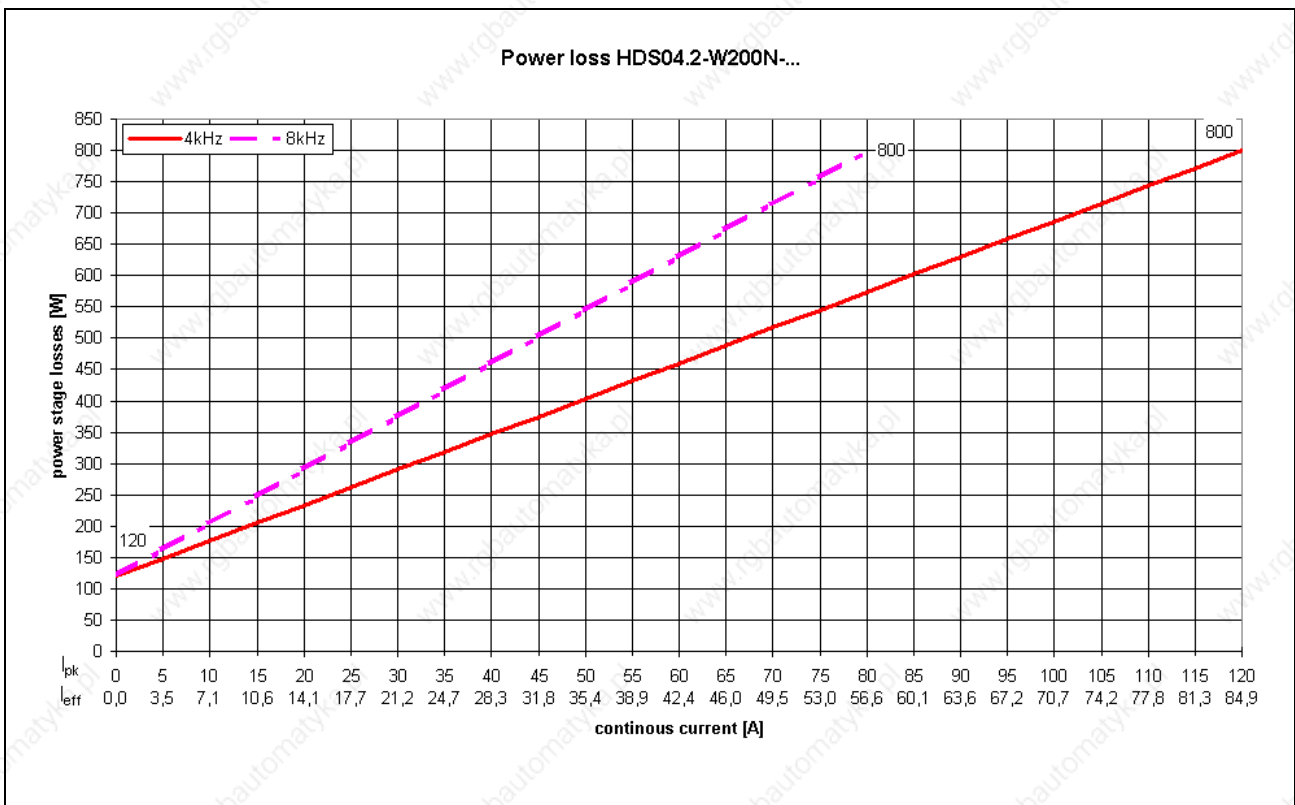

Fig. 7-5: Power loss HDS04.2W0200N-

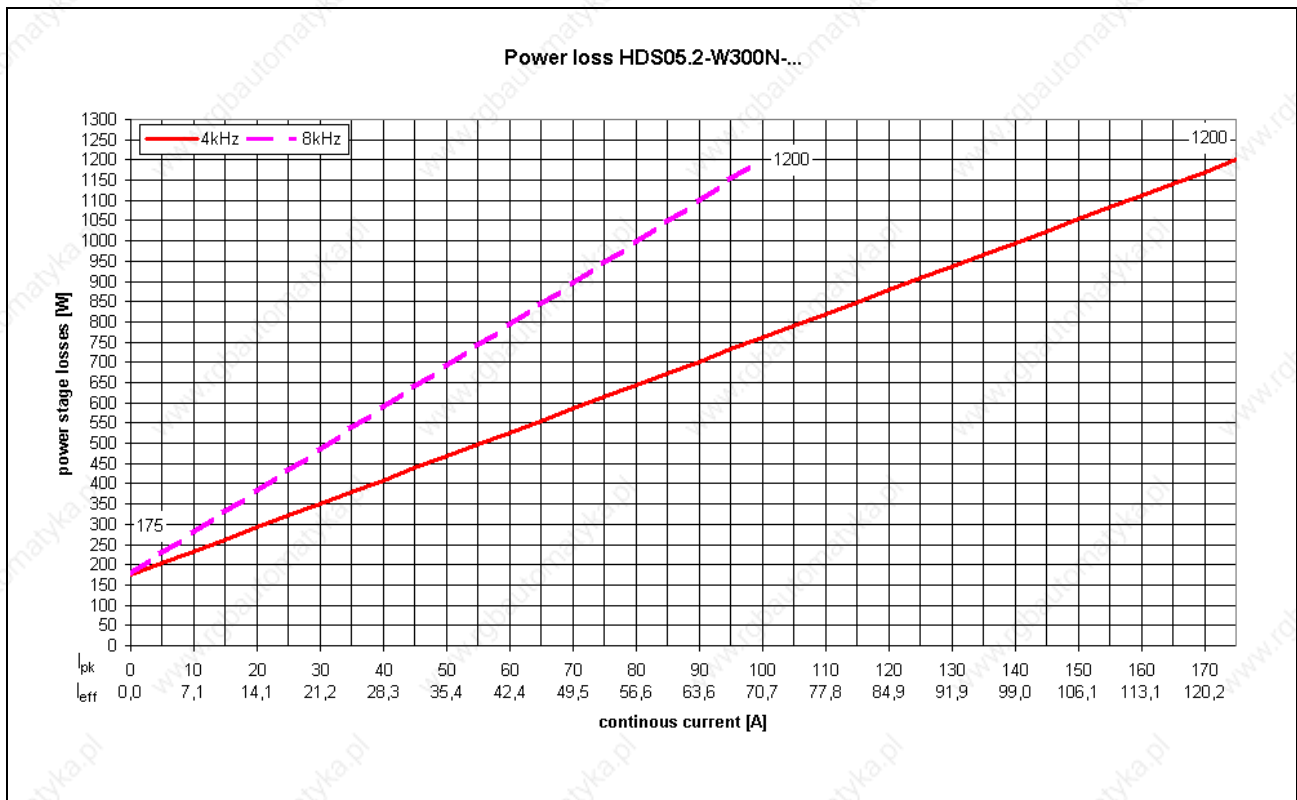

Fig. 7-6: Power loss HDS05.2W0300N-

Example calculation for a 4-axis drive system.

1st Drive	HDS04.2-W200N-HS32	continuous current	53A rms
	(Spindle)		
		controller power loss	30,0W
		system power loss	
		DSS02.1M	1,5W
		DLF01.1M	5,4W
		drive stage power loss (4kHz)	545W
		total 1	581,9W
2nd Drive	HDS03.2-W100N-HS30	continuous current	30Apk
		controller power loss	25,0W
		system power loss	
		DSS02.1M	1,5W
		DEA04.2M	1,6W
		DFF01.1M	3,6W
		drive stage power loss (4kHz)	188,0W
		Total 2	219,7W
3rd Drive	HDD02.2-W040N-HD32	Axis 1	continuous current 6Apk
		Axis 2	continuous current 3Apk
		controller power loss	45,0W
		loss Axis 1 (4kHz)	58,0W
		loss Axis 2 (4kHz)	40,0W
		total 3	143,0W
		Total drive controller losses	944,6W
		Total losses from supply-units	950,0W
		Power to be dissipated by the control cabinet	1894,6W

These power losses must be dissipated either via the metal structure of the cabinet itself or by means of a built-in cooling system.

7.3 The use of cooling system in the control cabinet

The controller may only be operated without a reduction of rated data up to an ambient temperature of 45° C. Therefore it may be necessary to use a cooling system.



CAUTION

Damage to controller is possible!

The operating safety of the machine is at risk.

⇒ Note the following instructions!

Avoid dripping or spraying water

The use of a cooling system results in water condensation. The following instructions must therefore be complied with:

- Cooling systems must always be arranged so that water condensation cannot drip onto the electronic equipment within the control cabinet.
- Cooling systems must be placed so that the water condensation collecting on the blower of the cooling system is not sprayed onto electronic equipment.

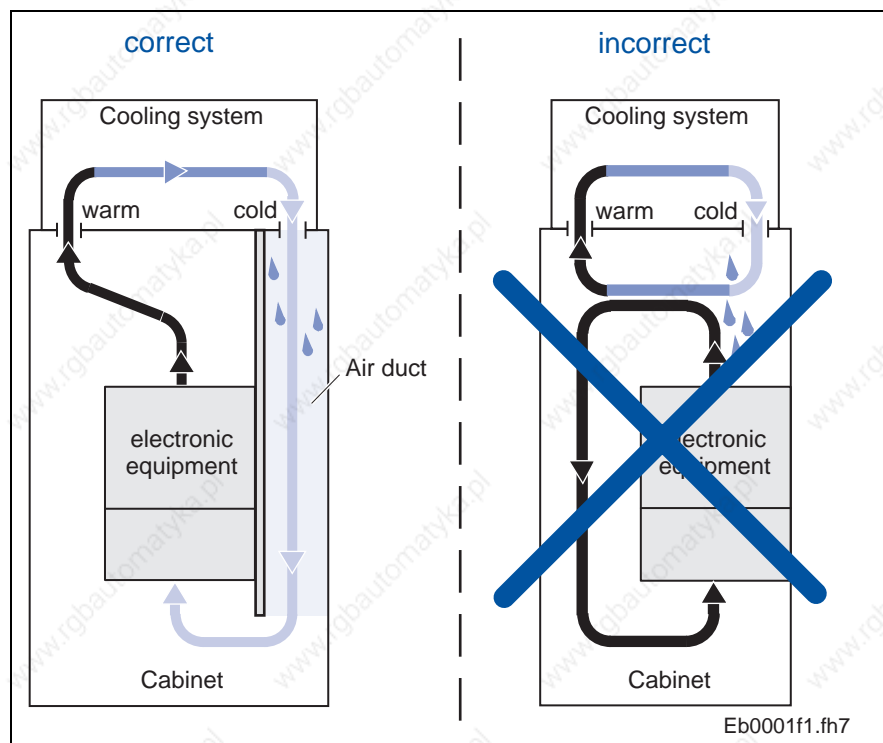

Fig. 7-7: Arranging the cooling system on the control cabinet

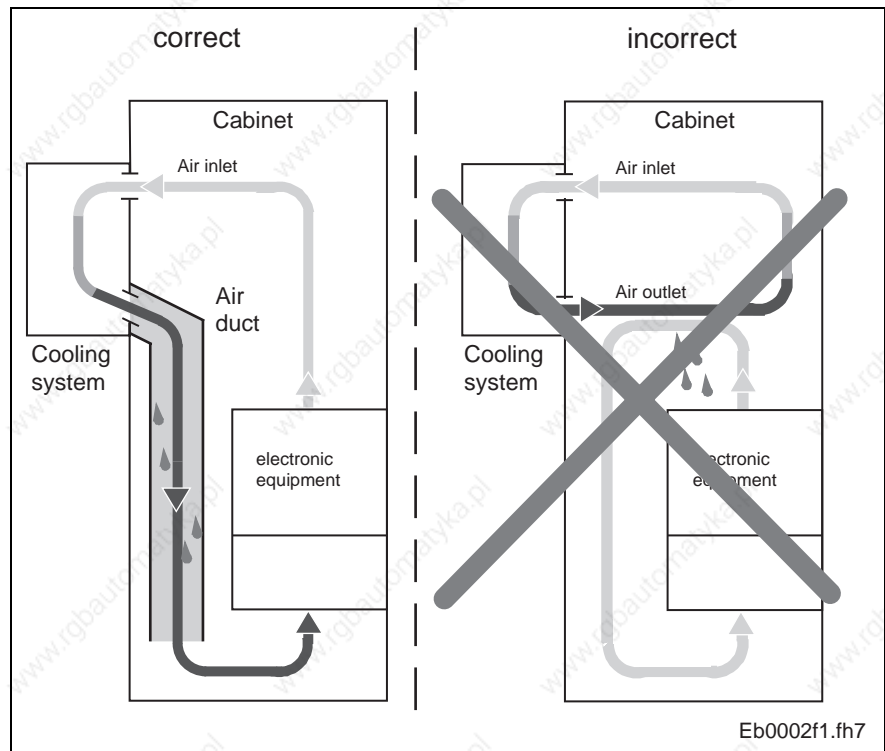

Fig. 7-8: Arranging the cooling system on the front of the control cabinet

Avoiding condensation

- Cooling systems must be set at 40° C and no lower!
- Cooling systems with self-adjusting temperature must be set so that the inside temperature of the control cabinet is not lower than that of outside. Temperature limit must be set at 40° C!
- Use only well-sealed control cabinet to avoid formation of condensation by humid air entering the cabinet.
- If the system must be operated with the control cabinet doors open (start-ups, servicing, etc.), then it must be ensured that, after the doors are closed, the controller is at no time cooler than the air in the cabinet. This could cause condensation. It is, therefore, necessary to run the cooling system even when the machine is off until the temperature of the air inside the control cabinet and that of the installed units is the same.

7.4 Connection lines

- Supply line routing**
- Observe a distance of at least 100 mm between power and control or signal cables (e.g. feedback cables) or
 - use a metal cable duct to isolate (see drawing)

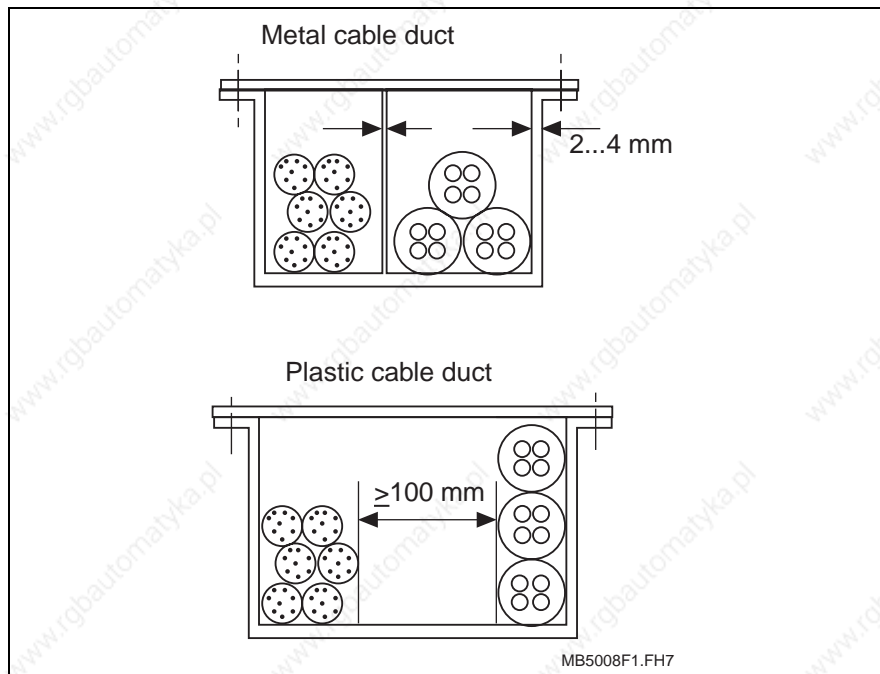

Fig. 7-9: Cable duct variants

- Do not route control or signal cables near high frequency units, magnetic fields (transformers, chokes, etc.) or high-voltage supply lines.

Line lengths

- Maximum motor cable length: 75 m
- Maximum feedback connection length: 75 m



CAUTION

Errors when controlling motors and moving components

Mechanical injuries!

⇒ Clamping points or couplings reduce the maximum line length. Note the following!

The line lengths specified apply to:

- direct connections between drive controller and motor
- ready-made cables from Rexroth Indramat and
- an ambient temperature of $\leq 40^\circ$ C per EN 60 204

7.5 Measures against interference sources in the control cabinet

To maintain the limits of class B (rf interference level N) per DIN VDE 0470-1, ed. 11.92 and table 1 per DIN EN 55014, ed. 12.93 at the machine (in particular when operating within a residential and light industrial area), the following applies:

- route motor power cable shielded or use a shielded motor power cable
- use shield attachment at the controller
- use a suitable interference suppression filter in the mains supply line of the machine or plant and make sure it is properly mounted and operated

If inductive loads (e.g. chokes, contactors or relays) are switched on and off by means of a contactor or semi-conductor, then these loads must be interference suppressed:

- use freewheeling diodes with three-phase current actuation
- use a contactor type-related RC-interference suppression module with alternating current actuation
- interference suppression elements must be mounted at the inductive load (e.g., contactor coil). The suppression effect could otherwise be considerably reduced.
- do not use varistors

If high-frequency equipment is to be used (e.g., components of anodizing devices):

- locate and wire such equipment outside of the control cabinet (depending on local conditions, a separate control cabinet may be necessary).

Note: For details see the Project Planning Manual "Electromagnetic Compatibility (EMC) in AC drives", documentation type: DOK-GENERL-EMV*****-PRXX-XX-P

Only the machine manufacturer can check whether the limit values are being maintained or not.

Notes

8 Accessories

8.1 Optic Fiber (OF)

Drives with SERCOS interface are connected via OF to the associated control.

The optic Fiber (cable, connector and/or ready-made OF) must be ordered separately.

Supplementary information about optic Fiber is outlined in the document "LWL Handling" (documentation number: 209-0090-4101-XX).

This document discusses the following points:

- OF in general
- basic plans for optical transmission systems
- routing instructions for OF
- dampening measurements of ready-made OF
- available OF-FSMA plug-in connectors and OF
- instructions on making an FSMA connector
- tools for making OF

Use the illustration below to determine the order information for the OF in the entire system.

Selecting OF connections

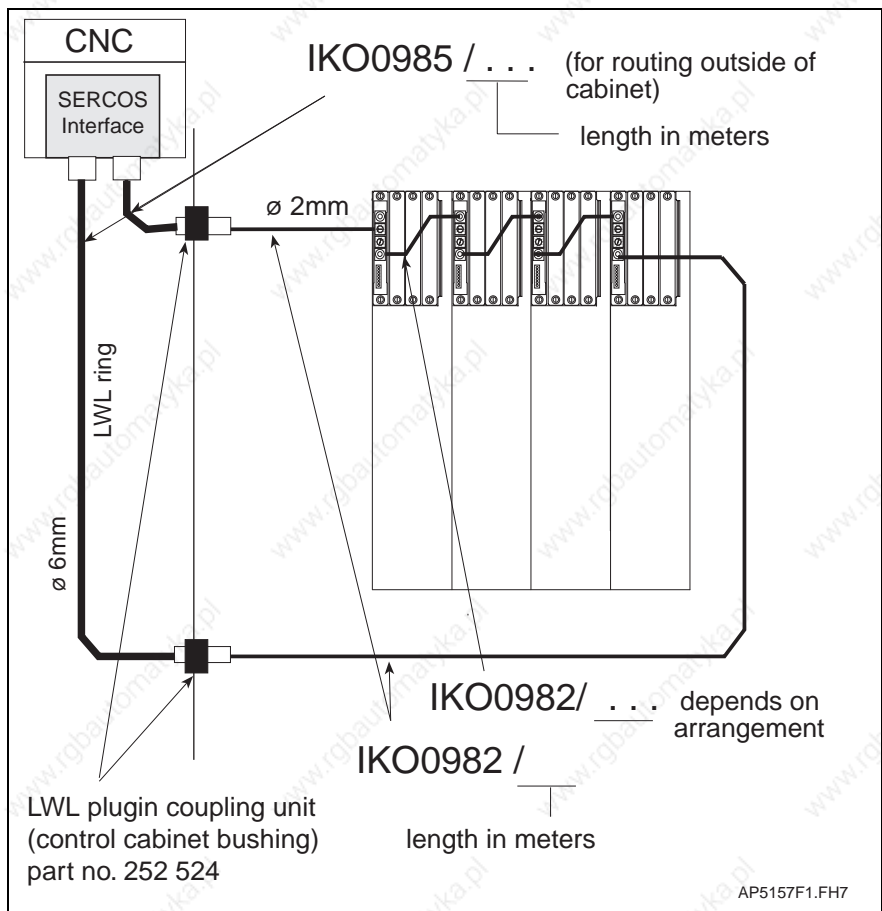

Fig. 8-1: Selecting ready-made OF

Notes

9 Transport and storage

9.1 General instructions

Transportation

- Use suitable transportation equipment.
- Use shock-absorbing supports, if excessive shocks and vibrations could occur during transport.
- Components that can be damaged by electrostatic discharge (e.g. plug-in modules) may only be transported in conductive packaging.

Storage

- Permissible temperature range for storage and transport: -30° C to +85° C
- Store dry, dust and shock free.
- Components that can be damaged by electrostatic discharge (e.g. plug-in modules) may only be stored in conductive packaging.

Notes

10 Identifying the merchandise

10.1 Delivery note and barcode sticker

The delivery note lists the merchandise of the entire delivery by name and order designation.

On the packaging of the controller itself there are barcode stickers which identifies it.



Fig. 10-1: Barcode sticker on the packaging of a HDD / HDS (Example)

10.2 Type plates of the drive controller HDS

- Position of the type plate** The controller is clearly identified by two type plates (see Fig. 10-2) :
- type plate of the basic unit (on the top of the unit)
 - type plate of the complete configuration (on the inserted card, next to the plug-in modules)

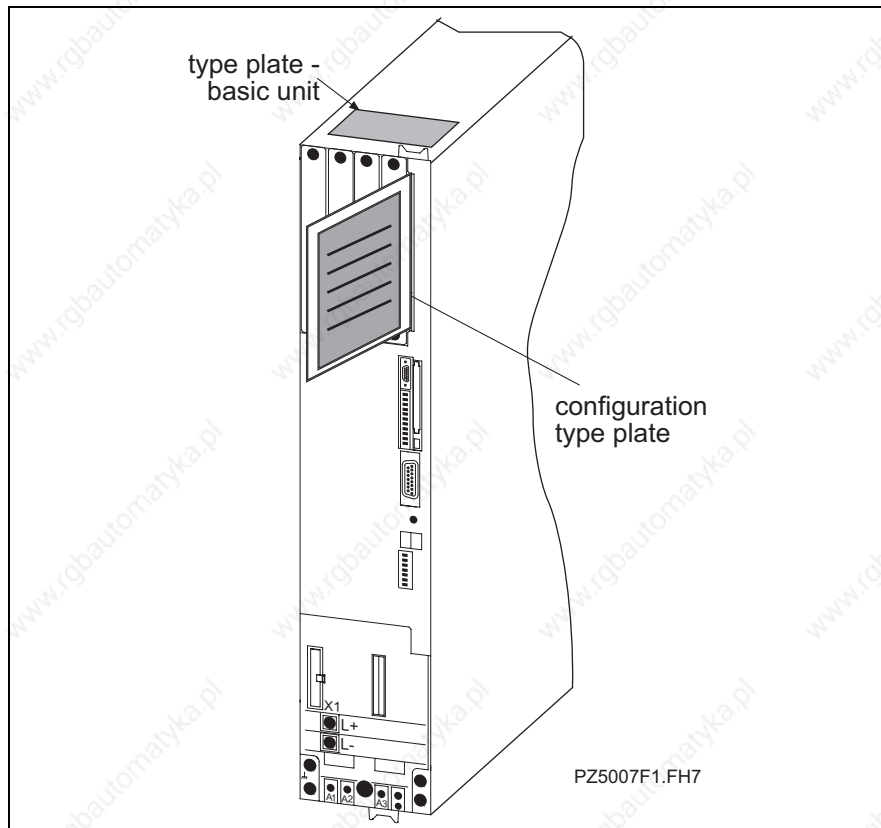

Fig. 10-2: Position of the type plates (HDS)

10.3 Type plates of the drive controller HDD

The controller is clearly identified by two type plates (see 10.3) :

- type plate of the basic unit (on the top of the unit)
- type plate (on the front plate)
- firmware

Position of the type plate



Abb. 10-3: Position of the type plates (HDD)

10.4 Other type plates

Firmware type plate The firmware type plate offers information on the type of firmware used (= drive operating software). Like the configuration type plate, it is situated on the inserted card, next to the plug-in modules.

Both firmware type plates are situated on the top of the HDD02.2-W40N-HD32 unit.

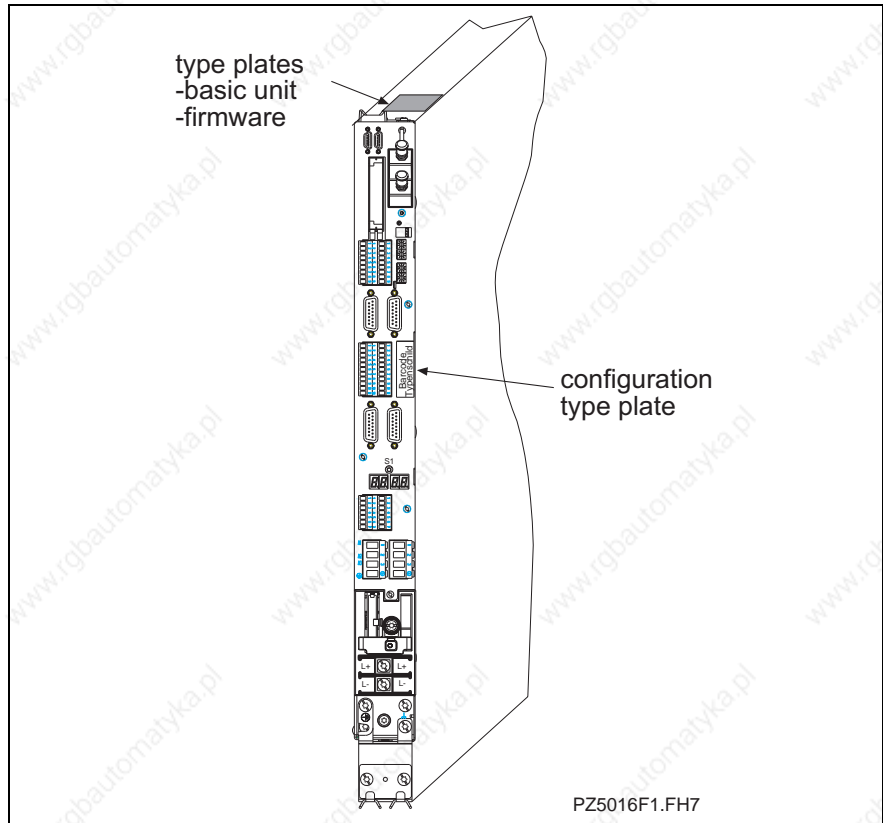
Ready-made cables The order number and the length of the cable are to be found on the cable label (cable marker).

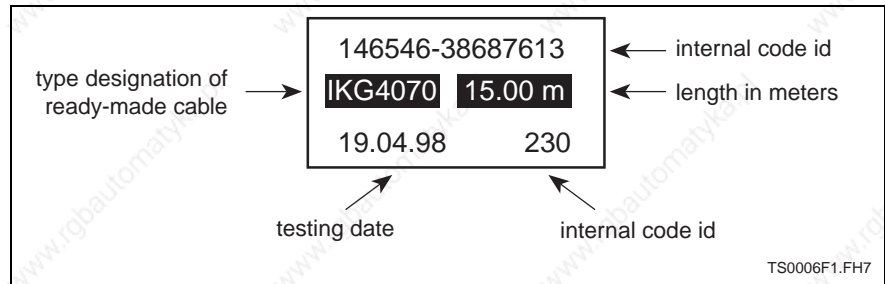

Fig. 10-4: Example: ready-made cable label

Cable parts Order designations for cable parts are printed on the cables.

11 Mounting and installation

11.1 Mounting the drive controller

Note: Please note permissible mounting conditions (see chapter 7 Planning the design of the control cabinet)

Arranging the controller

Arrange the drives with higher power needs and high currents as close to the supply unit as possible.

Ideally the axes should be distributed equally to the left and right side of the power supply.

If the total power $P_{m \text{ total}} > 36 \text{ kW}$ then the axes must be distributed equally on the left and right side corresponding to their individual power requirements i.e. 18 kW on each side of the supply.

(Exception: Single axis with $P_m > 36 \text{ kW}$)

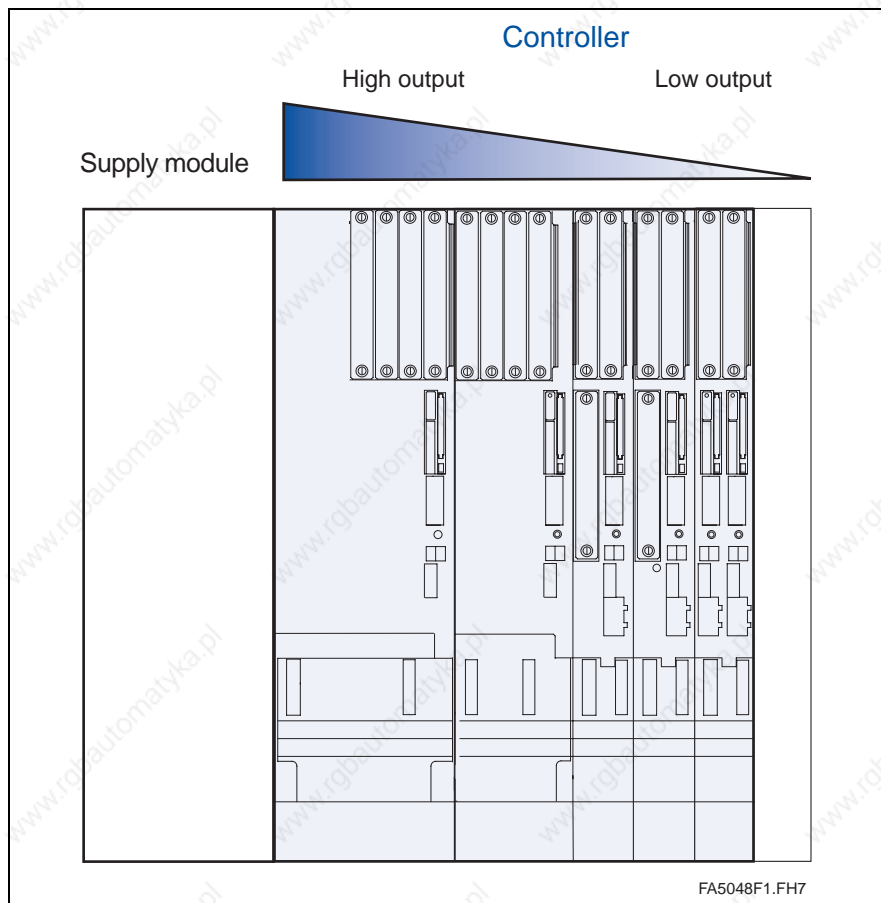

Fig. 11-1: Preferred arrangement of units in the control cabinet

Mounting position

After mounting the drive controller vertically, the motor connection has to be situated on the bottom of the unit.

Fastening the mounting rails

Mounting rails support the entire drive package. To be able to take up the corresponding forces it is necessary to fasten the rails in at least every second slot using an M5 screw.

As the mounting rails also conduct the potential compensation of the drives, there must be good contact of the mounting rails and the mounting panel. Therefore, it may be necessary to remove any paints or finishes on the mounting panel within the area of mounting!

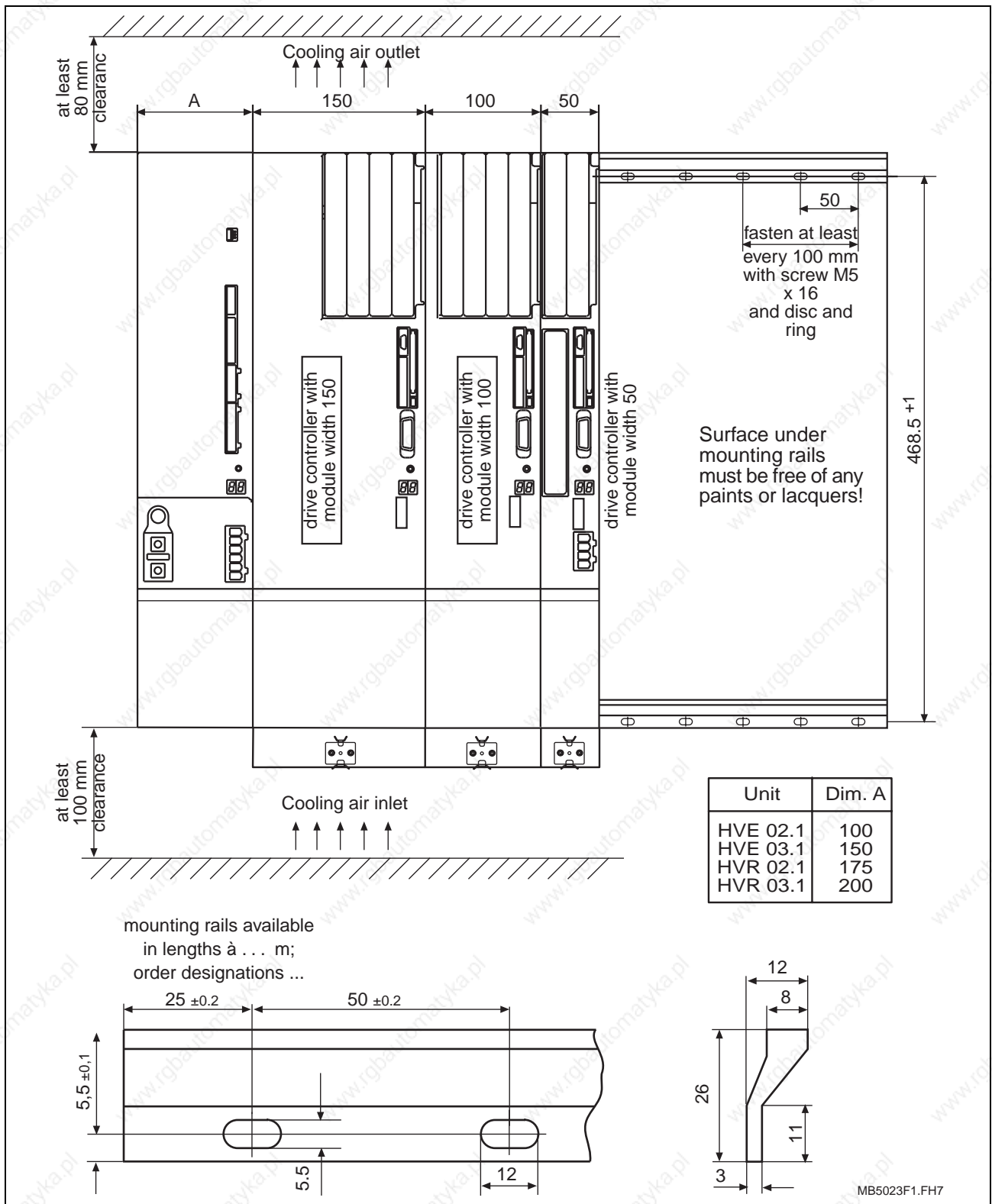

Fig. 11-2: Mounting and fastening the mounting rails

Mounting the drive controllers

1. Hang the drive controller onto the mounting rails.
2. Push drive controller to the adjacent unit.
3. Tighten clamping screw (see Fig. 11-3). 4 tightening torque Nm.

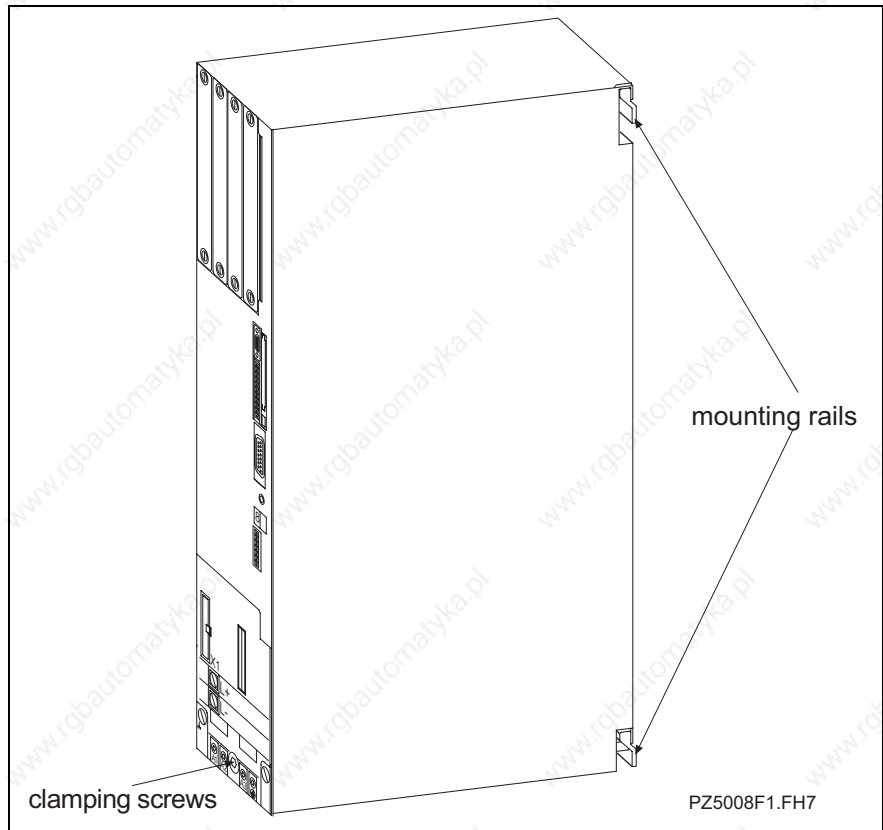

Fig. 11-3: Mounting the drive controller

11.2 Installation

- Establish ground connection with a grounding clip on the lower edge of the drive controller.
- DC bus screws for the power connections must be unscrewed on the bottom half of the unit and power connection to adjacent unit or supply unit must be connected.
- Close bus connection to adjacent unit using the integrated flat-ribbon cable.
- Connect motor power cable with protective conductor and shield.
- Connect motor temperature sensor and holding brake (optional).
- Connect motor feedback.

Notes

12 Service and testing

12.1 Error diagnoses

The controller generates drive error messages via

- the SERCOS interface and
- the status display H1 on the front of the unit

Diagnostic notes in the documentation In all controllers of the DIAX04 line, the meaning of the error messages and notes on fault clearance are identical. In the event of questions, just check the relevant function description.

Diagnostics via the Hotline If a problem cannot be dealt with by the user, then please feel free to contact our Rexroth Indramat customer service office nearest your location.

See also Supplement: Customer Service Locations - Sales & Service Facilities

Phone number Rexroth Indramat's customer service can be reached from Mondays to Fridays from 7.00 a.m. to 5 p.m. at the following phone number:
+49/9352/40 - 4894 and +49/9352/40 - 4922

Service Hotline The Service Hotline can be reached at **0172 / 66 00 406** or **0171 / 333 8826** during the following hours:

Monday to Friday:	5.00 am to 11.00 pm CET
Saturday:	8.00 am to 8.00 pm CET
Sundays and holidays:	9.00 am to 7.00 pm CET

Fig. 12-1: Rexroth Indramat hotline hours

To ensure a quick elimination of problems and errors, we would request you to note of the following prior to calling Rexroth Indramat customer service office:

- type data of the relevant controllers, motors and gears
- the failure status
- any error or diagnostics displays
- the software status.

12.2 Repairs and replacements

Repairs If the drive needs to be repaired, then:

- repairs may only be conducted by Rexroth Indramat customer service or appropriately trained personnel.

Unit or component replacement Unit and component replacement for all DIAX04 units is outlined in the document "DIAX04 - Troubleshooting Guide". After a unit is replaced, it is necessary to conduct a restart.

12.3 High voltage check and insulation check

Rexroth Indramat drive components are tested as per DIN VDE 0160 for high-voltage and insulation.

13 Index

A

Accessories 8-1
Additional plug-in module 4-2
Additional units 1-2
AK1 6-11
AK2 6-11
Ambient conditions 4-8
Ambient temperatures 4-8
Analog diagnostic outputs 6-11
ANALOG interface 4-2
analog outputs 6-11
Appropriate use
 Introduction 3-1
Appropriate uses
 Uses 3-2
Arrangement of cooling system 7-6
Arranging the controller 11-1
ASQ 6-12

B

barcode sticker 10-1
Basic unit 4-1, 4-2
Bb 6-12
Block diagram of the digital input circuit 6-25
Bus connection 6-7

C

Cable duct 7-8
Calculation of the drive controller losses 7-1
CLC-D02.3M 4-3
Command communication module 4-2
Complete shield 6-16
Component replacement 12-1
Condensation 7-7
Configuration 4-1
Configuration type plate 4-4
configuration type plate HDS 4-4
Configured drive controller 4-1
Connecting a PC to the RS 232 interface on a DKC 6-9
Connection cross section
 X2 6-8, 6-11
 X4 6-18
 X4 6-13
 X5 6-15
Connection diagram for measuring systems with voltage signals 6-21
Connection example of RS485 interface 6-10
Connection labelling 6-3, 6-4, 6-5, 6-6
Connection labelling HDS 6-2
Connector assignment - X3 6-11
Connector for integrated bus connections from the neighboring unit 6-7
Connector for RS485 interface 6-10
Connector X1 6-7
Connector X10/X11 6-23
Connector X12.1 / X12.2 6-25
Connector X2 6-8
Connector X3 6-11
Connector X4 6-13
Connector X5 6-15
Connector X7 6-20
Connector X7.1/X7.2 6-20

Control 4-3
control cabinet 7-1
Cooling system 7-6

D

DAG01.2M 4-3
DAK01.1M 4-3
DAK02.1M 4-3
DC Bus 6-16
DC bus voltage 6-17
DEA04.1M 4-2
DEA05.1M 4-2
DEA06.1M 4-2
DEA08.1M 4-2
DEA09.1M 4-2
DEA10.1M 4-2
DEA28.1M 4-2
DEA29.1M 4-2
DEA30.1M 4-2
DEF01.1M 4-2
DEF02.1M 4-2
Delivery slip 10-1
DFF01.1M 4-3
Diagnostic notes 12-1
Diagnostics 12-1
DIAX04 1-1
Digital I/O cards 4-2
Dimensional sheet HDS02.2 7-2, 7-3
Dimensional sheet HDS03.2 7-4
Dimensional sheet HDS04.2 7-5
Dimensional sheet HDS05.2 7-6
Dimensional sheets 7-1
DLF 01.1M 6-20
DLF01.1M 4-2
DRF01.1M 4-3
drive controller 4-1
Drive controllers HDS 4-1
Drive Package - DIAX04 1-1
DSA01.1M 4-3
DZF02.1M 4-3
DZF03.1M 4-3

E

Encoder 1 6-14
Error diagnoses 12-1
Example calculation for a 4-axis drive system 7-5
Exceeding rated data 4-8
External voltage tests 12-2

F

feedback cables 7-8
Firmware 4-2
Firmware type plate 10-4

G

Ground connections 6-16
Ground connections - controller 6-16
Grounded conductor connection 6-16
Grounding clip 6-16

H

HDD02.2-W040N-HD32 5-1
High-resolution positioning interface for sinusoidal signals 6-20
Holding brake 6-19

Holding brake control 6-19
Hotline 12-1
HSM 4-2

I

Inappropriate use 3-2
 Consequences, Discharge of liability 3-1
Individual components 1-2
Inputs (HDD) 6-25
Installation 11-1, 11-3
Installation elevation 4-8
Interface card 4-2
Interfacekarten 4-3
interference sources 7-9
Interference sources 7-9
Intermediate circuit, motor, and power connections 6-16

L

Line lengths 6-17, 7-8

M

Measures against interference sources in the control cabinet 7-9
Measuring system 4-2
Motor cable 6-19
Motor connection 6-16
motor feedback 6-13
Motor holding brake 6-16
Motor power cable 6-16
Motor power cable connection 6-16
Motor temperature monitor 6-16
Mounting 11-1
Mounting and fastening the mounting rails 11-2
Mounting position 11-1
Mounting rail 7-1
Mounting rails 11-1
Mounting the drive controllers 11-3

O

OF (Optic Fiber) 8-1
Operating software 4-2
optic Fiber 8-1

P

Packaging 10-1
Phone number 12-1
plug-in module 4-2
Plug-in modules 4-1
Position of the type plate 10-2, 10-3
Potential-free feedback contact 6-12
Power consumption of the plug-in modules 4-7
Power loss HDD02.2W040N 7-1
Power loss HDS02.2W040N- 7-2
Power loss HDS03.2W0100N- 7-3
Power loss HDS03.2W075N- 7-2
Power loss HDS04.2W0200N- 7-3
Power loss HDS05.2W0300N- 7-4
Preferred arrangement of units in the control cabinet 11-1
Protection category 4-8

R

Rated data 4-8
ready to operate 6-11
Ready to operate contact 6-12

ready-made cable label 10-4
Ready-made cables 10-4
Repairs 12-1
Replacements 12-1
RS 232 interface 6-9
RS 485 Interface 6-9

S

Safety Instructions for Electric Servo Drives and Controls 2-1
Selecting OF connections 8-1
Selecting ready-made OF 8-1
SERCOS interface 4-2, 6-23
serial bus 6-9
Serial interface 6-8
Service 12-1
Setting of the transmitter power 6-23
Signal assignment of measuring systems with voltage signals 6-21
signal cables 7-8
Sinusoidal signals 6-20
Software module 4-2
starting lockout 6-11
Starting lockout AS 6-12
Sticker 10-1
Storage 9-1
Supply line routing 7-8
Supply lines 7-8
Supply module 1-2
System 1-1

T

Technical data 4-6
Technical data of connector 6-7, 6-8, 6-11, 6-18
 X4 6-13
Technical data of connector X5 6-16
Technical data of HDD and HDS 4-6
Technical data of the connecting terminal X10 / X11 6-23
Technical data of the connecting terminal X12.1 / X12.2 6-25
Technical data of the connecting terminal X7.1 / X7.2 6-20
Temperature monitor 6-19
Testing 12-1
The use of cooling system in the control cabinet 7-6
Tightening
 X5 6-16
Tightening torques
 X5 6-16
Transport and Storage 9-1
Transportation 9-1
Type codes HDD HDD02.2-W040-HD32 5-2
Type codes HDS 4-5
type designations 4-4
Type plate 10-2, 10-3
type plates (HDD) 10-3
type plates (HDS) 10-2

U

Use *See appropriate use and see inappropriate use*

X

X12.1/X12.2 6-25
X4, Motor Feedback Connector 6-13
X6 Holding brake, motor temperature monitoring 6-18
X7.1/X7.2 6-20

Notes

14 Service & Support

14.1 Helpdesk

Unser Kundendienst-Helpdesk im Hauptwerk Lohr am Main steht Ihnen mit Rat und Tat zur Seite. Sie erreichen uns

- telefonisch: **+49 (0) 9352 40 50 60**
über Service-Call Entry Center Mo-Fr 07:00-18:00
- per Fax: **+49 (0) 9352 40 49 41**
- per e-Mail: **service@indramat.de**

Our service helpdesk in the head factory Lohr am Main is assisting you in all kind of queries. You may contact us

- by phone: **+49 (0) 9352 40 50 60**
via Service-Call Entry Center Mo-Fr 07:00-18:00
- by fax: **+49 (0) 9352 40 49 41**
- by e-mail: **service@indramat.de**

14.2 Service-Hotline

Außerhalb der Helpdesk-Zeiten ist der Service direkt ansprechbar unter

+49 (0) 171 333 88 26
oder **+49 (0) 172 660 04 06**

Beyond the helpdesk hours, our service is directly contactable under

+49 (0) 171 333 88 26
or **+49 (0) 172 660 04 06**

14.3 Internet - Worldwide Web

Weitere Hinweise zu Service, Reparatur und Training finden Sie im Internet unter

www.indramat.de

Außerhalb Deutschlands nehmen Sie bitte zuerst Kontakt mit Ihrem lokalen Ansprechpartner auf. Die Adressen sind im Anhang aufgeführt.

Further hints about service, repairs and training are available in the worldwide web under

www.indramat.de

Please don't hesitate to contact first the sales & service agencies in your area. Refer to the addresses are on the following pages.

14.4 Vor der Kontaktaufnahme...

...before contacting us



Wir können Ihnen schnell und effizient helfen wenn Sie folgende Informationen bereithalten:



1. detaillierte Beschreibung der Störung und der Umstände.
2. Angaben auf dem Typenschild der betreffenden Produkte, insbesondere Typenschlüssel und Seriennummern.
3. Telefon-/Faxnummern und e-Mail-Adresse, unter denen Sie für Rückfragen zu erreichen sind.

To enable us for quick and efficient help, please prepare the following information:

1. most detailed description of the failure appearance.
2. Indications on the typelabel of the concerned products, especially typecodes and serialnumbers.
3. Telephone-/faxnumbers and e-mail address by which we can attend you in case of queries.

14.5 Kundenbetreuungsstellen Sales & Service Facilities

 Verkaufsniederlassungen
 Niederlassungen mit Kundendienst

 sales agencies
 agencies providing service

Deutschland – Germany

vom Ausland: (0) nach Landeskennziffer weglassen!!
from abroad: don't dial (0) after country code!

Vertriebsgebiet Mitte Germany Centre Rexroth Indramat GmbH Bgm.-Dr.-Nebel-Str. 2 97816 Lohr am Main Kompetenz-Zentrum Europa Telefon: +49 (0)9352 40-0 Telefax: +49 (0)9352 40-4885	SERVICE CALL ENTRY CENTER MO – FR von 07:00 - 18:00 Uhr from 7 am – 6 pm Tel. +49 (0) 9352 40 50 60 service@indramat.de	SERVICE HOTLINE MO – FR von 17:00 - 07:00 Uhr from 5 pm - 7 am + SA / SO Tel.: +49 (0)172 660 04 06 oder / or Tel.: +49 (0)171 333 88 26	SERVICE ERSATZTEILE / SPARES verlängerte Ansprechzeit - extended office time - ♦ nur an Werktagen - only on working days - ♦ von 07:00 - 18:00 Uhr - from 7 am - 6 pm - Tel. +49 (0) 9352 40 42 22
Vertriebsgebiet Süd Germany South Rexroth Indramat GmbH Ridlerstraße 75 80339 München Telefon: +49 (0)89 540138-30 Telefax: +49 (0)89 540138-10 indramat.mue@t-online.de	Gebiet Südwest Germany South-West Mannesmann Rexroth AG Vertrieb Deutschland – VD-BI Geschäftsbereich Rexroth Indramat Regionalzentrum Südwest Ringstrasse 70 / Postfach 1144 70736 Fellbach / 70701 Fellbach Tel.: +49 (0)711 57 61-100 Fax: +49 (0)711 57 61-125	Vertriebsgebiet Ost Germany East Rexroth Indramat GmbH Beckerstraße 31 09120 Chemnitz Telefon: +49 (0)371 35 55-0 Telefax: +49 (0)371 35 55-333	Vertriebsgebiet Nord Germany North Mannesmann Rexroth AG Vertriebsniederlassung Region Nord Gesch.ber. Rexroth Indramat Walsroder Str. 93 30853 Langenhagen Telefon: +49 (0) 511 72 66 57-0 Telefax: +49 (0) 511 72 66 57-93
Vertriebsgebiet West Germany West Mannesmann Rexroth AG Vertrieb Deutschland Regionalzentrum West Borsigstrasse 15 40880 Ratingen Telefon: +49 (0)2102 409-0 Telefax: +49 (0)2102 409-406	Vertriebsgebiet Mitte Germany Centre Mannesmann Rexroth AG Gesch.ber. Rexroth Indramat Lilistraße 14-18 63067 Offenbach Telefon: +49 (0) 69 82 00 90-0 Telefax: +49 (0) 69 82 00 90-80	Vertriebsgebiet Ost Germany East Mannesmann Rexroth AG GB Rexroth Indramat GmbH Holzhäuser Str. 122 04299 Leipzig Telefon: +49 (0)341 86 77-0 Telefax: +49 (0)341 86 77-219	Vertriebsgebiet Nord Germany North Rexroth Indramat GmbH Kieler Straße 212 22525 Hamburg Telefon: +49 (0)40 85 31 57-0 Telefax: +49 (0)40 85 31 57-15

Europa – Europe

vom Ausland: (0) nach Landeskennziffer weglassen, **Italien:** 0 nach Landeskennziffer mitwählen
from abroad: don't dial (0) after country code, **Italy:** dial 0 after country code

Austria Mannesmann Rexroth Ges.m.b.H. Gesch.ber. Rexroth Indramat Hägelingasse 3 1140 Wien Telefon: +43 (0)1 9852540-400 Telefax: +43 (0)1 9852540-93	Austria Mannesmann Rexroth G.m.b.H. Gesch.ber. Rexroth Indramat Industriepark 18 4061 Pasching Telefon: +43 (0)7221 605-0 Telefax: +43 (0)7221 605-21	Belgium Mannesmann Rexroth N.V.-S.A. Gesch.ber. Rexroth Indramat Industrielaan 8 1740 Ternat Telefon: +32 (0)2 5830719 Telefax: +32 (0)2 5830731 indramat@rexroth.be	Denmark BEC AS Zinkvej 6 8900 Randers Telefon: +45 (0)87 11 90 60 Telefax: +45 (0)87 11 90 61
Czech Republic Mannesmann-Rexroth, spol.s.r.o. Hviezdoslavova 5 627 00 Brno Telefon: +420 (0)5 48 126 358 Telefax: +420 (0)5 48 126 112	England Mannesmann Rexroth Ltd. Rexroth Indramat Division Broadway Lane, South Cerney Cirencester, Glos GL7 5UH Telefon: +44 (0)1285 863000 Telefax: +44 (0)1285 863030	Finland Rexroth Mecman Oy Rexroth Indramat division Ansatie 6 017 40 Vantaa Telefon: +358 (0)9 84 91-11 Telefax: +358 (0)9 84 91-13 60	France Mannesmann Rexroth S.A. Division Rexroth Indramat Parc des Barbanniers 4, Place du Village 92632 Gennevilliers Cedex Telefon: +33 (0)141 47 54 30 Telefax: +33 (0)147 94 69 41 Hotline: +33 (0)608 33 43 28
France Mannesmann Rexroth S.A. Division Rexroth Indramat 270, Avenue de Lardenne 31100 Toulouse Telefon: +33 (0)5 61 49 95 19 Telefax: +33 (0)5 61 31 00 41	France Mannesmann Rexroth S.A. Division Rexroth Indramat 91, Bd. Irène Joliot-Curie 69634 Vénissieux – Cedex Telefon: +33 (0)4 78 78 53 65 Telefax: +33 (0)4 78 78 53 62	Hungary Mannesmann Rexroth Kft. Angol utca 34 1149 Budapest Telefon: +36 (1) 364 00 02 Telefax: +36 (1) 383 19 80	Italy Mannesmann Rexroth S.p.A. Divisione Rexroth Indramat Via G. Di Vittoria, 1 20063 Cernusco S/N.MI Telefon: +39 02 2 365 270 Telefax: +39 02 700 408 252378
Italy Mannesmann Rexroth S.p.A. Divisione Rexroth Indramat Via Borgomanero, 11 10145 Torino Telefon: +39 011 7 50 38 11 Telefax: +39 011 7 71 01 90	Italy Mannesmann Rexroth S.p.A. Divisione Rexroth Indramat Via del Progresso, 16 (Zona Ind.) 35020 Padova Telefon: +39 049 8 70 13 70 Telefax: +39 049 8 70 13 77	Italy Mannesmann Rexroth S.p.A. Rexroth Indramat Via Mascia, 1 80053 Castellammare di Stabia NA Telefon: +39 081 8 71 57 00 Telefax: +39 081 8 71 68 85	Italy Mannesmann Rexroth S.p.A. Divisione Rexroth Indramat Viale Oriani, 38/A 40137 Bologna Telefon: +39 051 34 14 14 Telefax: +39 051 34 14 22
Netherlands Rexroth B.V. Kruisbroeksestraat 1 (P.O. Box 32) 5281 RV Boxtel Telefon: +31 (0)411 65 19 51 Telefax: +31 (0)411 65 14 83 indramat@hydraudyne.nl	Netherlands Rexroth Hydrocare B.V. Kruisbroeksestraat 1 (P.O. Box 32) 5281 RV Boxtel Telefon: +31 (0)411 65 19 51 Telefax: +31 (0)411 67 78 14	Norway Rexroth Mecman AS Divisione Rexroth Indramat Berghagan 1 or: Box 3007 1405 Ski-Langhus 1402 Ski Telefon: +47 (0)64 86 41 00 Telefax: +47 (0)64 86 90 62	Poland Mannesmann Rexroth Sp.zo.o. Biuro Poznan ul. Dabrowskiego 81/85 60-529 Poznan Telefon: +48 061 847 67 99 Telefax: +48 061 847 64 02
Rumania Mannesmann Rexroth Sp.zo.o. Str. Drobety nr. 4-10, app. 14 70258 Bucuresti, Sector 2 Telefon: +40 (0)1 210 48 25 +40 (0)1 210 29 50 Telefax: +40 (0)1 210 29 52	Russia Tschudnenko E.B. Arsenia 22 153000 Ivanovo Telefon: +7 093 223 96 33 oder/or +7 093 223 95 48 Telefax: +7 093 223 46 01	Spain Mannesmann Rexroth S.A. Division Rexroth Indramat Centro Industrial Santiga Obradors s/n 08130 Santa Perpetua de Mogoda Barcelona Telefon: +34 9 37 47 94 00 Telefax: +34 9 37 47 94 01	Spain Goimendi S.A. Division Rexroth Indramat Parque Empresarial Zuatzu C/ Francisco Montagne no.2 20018 San Sebastian Telefon: +34 9 43 31 84 21 - service: +34 9 43 31 84 56 Telefax: +34 9 43 31 84 27 - service: +34 9 43 31 84 60 satindramat-goimendi@adegi.es
Sweden Rexroth Mecman Svenska AB Rexroth Indramat Division Varuvägen 7 125 81 Stockholm Telefon: +46 (0)8 727 92 00 Telefax: +46 (0)8 647 32 77	Slowenia Rexroth Indramat elektromotorji d.o.o. Otoki 21 64 228 Zelezniki Telefon: +386 64 61 73 32 Telefax: +386 64 64 71 50	Switzerland -East- Mannesmann Rexroth Schweiz AG Gesch.ber. Rexroth Indramat Gewerbstraße 3 8500 Frauenfeld Telefon: +41 (0)52 720 21 00 Telefax: +41 (0)52 720 21 11	Switzerland -West- Mannesmann Rexroth Suisse SA Département Rexroth Indramat Rue du village 1 1020 Renens Telefon: +41 (0)21 632 84 20 Telefax: +41 (0)21 632 84 21
Turkey Mannesmann Rexroth Hidropar A.S. Fevzi Cakmak Cad No. 3 34630 Sefaköy Istanbul Telefon: +90 212 541 60 70 Telefax: +90 212 599 34 07			

Africa, Asia, Australia – incl. Pacific Rim

vom Ausland:
from abroad:

(x) nach Landeskenziffer weglassen!
don't dial (x) after country code!

Australia AIMS - Australian Industrial Machinery Services Pty. Ltd. Unit 3/45 Horne ST Campbellfield, VIC 3061 Melbourne Telefon: +61 (0)3 93 59 02 28 Telefax: +61 (0)3 93 59 02 86	Australia Mannesmann Rexroth Pty. Ltd. No. 7, Endeavour Way Braeside Victoria, 31 95 Melbourne Telefon: +61 (0)3 95 80 39 33 Telefax: +61 (0)3 95 80 17 33 mel@rexroth.com.au	China Shanghai Mannesmann Rexroth Hydraulics & Automation Ltd. Wai Gaoqiao Free Trade Zone No.122, Fu Te Dong Yi Road Shanghai 200131 - P.R.China Telefon: +86 21 58 66 30 30 Telefax: +86 21 58 66 55 23	China Mannesmann Rexroth (China) Ltd. 15/F China World Trade Center 1, Jianguomenwai Avenue Beijing 100004, P.R.China Telefon: +86 10 65 05 03 80 Telefax: +86 10 65 05 03 79
China Mannesmann Rexroth (China) Ltd. A-5F., 123 Lian Shan Street Sha He Kou District Dalian 116 023, P.R.China Telefon: +86 411 46 78 930 Telefax: +86 411 46 78 932	China Mannesmann Rexroth (China) Ltd. Guangzhou Repres. Office Room 1014-1016, Metro Plaza, Tian He District, 183 Tian He Bei Rd Guangzhou 510075, P.R.China Telefon: +86 20 8755-0030 +86 20 8755-0011 Telefax: +86 20 8755-2387	Hongkong Rexroth (China) Ltd. 1/F., 19 Cheung Shun Street Cheung Sha Wan, Kowloon, Hongkong Telefon: +852 22 62 51 00 Telefax: +852 27 41 33 44	India Mannesmann Rexroth (India) Ltd. Rexroth Indramat Division Plot. A-58, TTC Industrial Area Thane Turbhe Midc Road Mahape Village Navi Mumbai - 400 701 Telefon: +91 (0)22 7 61 46 22 Telefax: +91 (0)22 7 68 15 31
India Mannesmann Rexroth (India) Ltd. Rexroth Indramat Division Plot. 96, Phase III Peenya Industrial Area Bangalore - 560058 Telefon: +91 (0)80 8 39 73 74 Telefax: +91 (0)80 8 39 43 45	Indonesia PT. Rexroth Wijayakusuma Jl. Raya Bekasi Km 21 Pulogadung Jakarta Timur 13920 Telefon: +62 21 4 61 04 87 +62 21 4 61 04 88 Telefax: +62 21 4 60 01 52	Japan Rexroth Automation Co., Ltd. Service Center Japan Yutakagaoka 1810, Meito-ku, NAGOYA 465-0035, Japan Telefon: +81 (0)52 777 88 41 +81 (0)52 777 88 53 +81 (0)52 777 88 79 Telefax: +81 (0)52 777 89 01	Japan Rexroth Automation Co., Ltd. Rexroth Indramat Division 1F, I.R. Building Nakamachidai 4-26-44, Tsuzuki-ku YOKOHAMA 224-0041, Japan Telefon: +81 (0)45 942 72 10 Telefax: +81 (0)45 942 03 41
Korea Mannesmann Rexroth-Korea Ltd. Rexroth Indramat Division 1500-12 Dadae-Dong- Saha-Ku Pusan, 604-050 Republic of South Korea Telefon: +82 (0)51 26 00 741 Telefax: +82 (0)51 26 00 747 gyhan@rexrothkorea.co.kr	South Africa TECTRA Automation (Pty) Ltd. 28 Banfield Road, Industria North RSA - Maraisburg 1700 Telefon: +27 (0)11 673 20 80 Telefax: +27 (0)11 673 72 69	Taiwan Rexroth Uchida Co., Ltd. No.17, Lane 136, Cheng Bei 1 Rd., Yungkang, Tainan Hsien Taiwan, R.O.C. Telefon: +886 (0)6 25 36 565 Telefax: +886 (0)6 25 34 754	Thailand NC Advance Technologies Co. Ltd. 59/76 Moo 9 Soi Ramintra 34 Ramintra Road, Tharang, Bangkhen Bangkok 10220 Telefon: +66 2 943 70 62 +66 2 943 71 21 Telefax: +66 2 509 23 62 sonkawin@hotmail.com

Nordamerika – North America

<p>USA</p> <p>Mannesmann Rexroth Corporation Rexroth Indramat Division 5150 Prairie Stone Parkway Hoffman Estates, IL 60192-3707</p> <p>Competence Centre America</p> <p>Telefon: +1 847 6 45 36 00 Telefax: +1 847 6 45 62 01 service@indramat.com</p>	<p>USA</p> <p>Mannesmann Rexroth Corporation Rexroth Indramat Division Central Region Technical Center Auburn Hills, MI 48326</p> <p>Telefon: +1 248 3 93 33 30 Telefax: +1 248 3 93 29 06</p>	<p>USA</p> <p>Mannesmann Rexroth Corporation Rexroth Indramat Division Southeastern Technical Center 3625 Swiftwater Park Drive Suwanee, Georgia 30174</p> <p>Telefon: +1 770 9 32 32 00 Telefax: +1 770 9 32 19 03</p>	<p>USA</p> <p>HOTLINE</p> <p>- 7 days x 24hrs -</p> <p>+1-800-860-1055</p>
<p>USA</p> <p>Mannesmann Rexroth Corporation Rexroth Indramat Division Charlotte Regional Sales Office 14001 South Lakes Drive Charlotte, North Carolina 28273</p> <p>Telefon: +1 704 5 83 97 62 +1 704 5 83 14 86</p>	<p>USA</p> <p>Mannesmann Rexroth Corporation Rexroth Indramat Division Northeastern Technical Center 99 Rainbow Road East Granby, Connecticut 06026</p> <p>Telefon: +1 860 8 44 83 77 Telefax: +1 860 8 44 85 95</p>	<p>Canada East</p> <p>Basic Technologies Corporation Burlington Division 3426 Mainway Drive Burlington, Ontario Canada L7M 1A8</p> <p>Telefon: +1 905 335 55 11 Telefax: +1 905 335-41 84</p>	<p>Canada West</p> <p>Basic Automation Burnaby 5345 Goring St. Burnaby, British Columbia Canada V7J 1R1</p> <p>Tel. +1 604 205-5777 Fax +1 604 205-6944 dave.gunby@basic.ca</p>

Südamerika – South America

<p>Argentina</p> <p>Mannesmann Rexroth S.A.I.C. Division Rexroth Indramat Acassusso 48 41/7 RA - 1605 Munro (Buenos Aires)</p> <p>Telefon: +54 (0)11 4756 01 40 Telefax: +54 (0)11 4762 6862 mannesmann@mannesmannsaic.com.ar</p>	<p>Argentina</p> <p>NAKASE Servicio Tecnico CNC Calle 49, No. 5764/66 RA - 1653 Villa Balester Prov. - Buenos Aires</p> <p>Telefon: +54 (0) 11 4768 36 43 Telefax: +54 (0) 11 4768 24 13 nakase@usa.net nakase@infovia.com.ar</p>	<p>Brazil</p> <p>Mannesmann Rexroth Automação Ltda. Divisão Rexroth Indramat Rua Georg Rexroth, 609 Vila Padre Anchieta BR - 09951-270 Diadema-SP [Caixa Postal 377] [BR-09901-970 Diadema-SP]</p> <p>Telefon: +55 (0)11 4075 90 60 +55 (0)11 4075 90 70 Telefax: +55 (0)11 4075 35 52 awittwer@rexroth.com.br</p>	<p>Brazil</p> <p>Mannesmann Rexroth Automação Ltda. Divisão Rexroth Indramat R. Dr.Humberto Pinheiro Vieira, 100 Distrito Industrial BR - 89220-390 Joinville - SC [Caixa Postal 1273]</p> <p>Tel./Fax: +55 (0)47 473 58 33 Mobil: +55 (0)47 974 66 45 prochnow@zaz.com.br</p>
<p>Mexico</p> <p>Mannesmann Rexroth Mexico S.A. de C.V. Calle Neptuno 72 Unidad Ind. Vallejo MEX - 07700 Mexico, D.F.</p> <p>Telefon: +52 5 754 17 11 +52 5 754 36 84 +52 5 754 12 60 Telefax: +52 5 754 50 73 +52 5 752 59 43</p>			

Notes



2 8 0 4 4 6



Printed in Germany