

Frequency inverters | Dematik EPU-V-H and DPU-V-H
for AC motors up to 1.5 kW

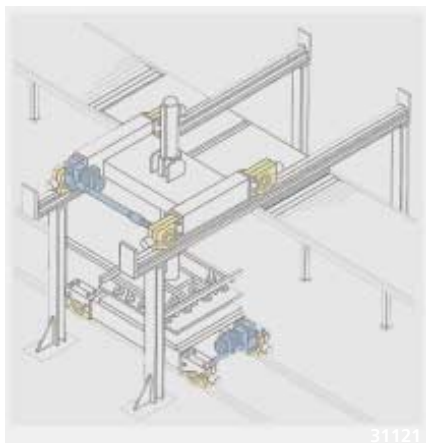

Dematik EPU/DPU-V-H frequency inverters: major advantages for small motors



Years of drive engineering experience, control technology expertise and state-of-the-art electronic design are now incorporated in frequency inverters for demanding variable-speed starting and stopping and travel drive applications in the low output range up to 1.5 kW.

In addition to the benefits offered by infinitely variable speed control, the Dematik EPU/DPU-V-H range also features high dynamics combined with precision and reliability. The interface arrangement provides a maximum of performance for a minimum space requirement, while offering a variety of practical features and advantages.

Features and advantages

- compact design
- hat rail mounting acc. to IEC or 19" rack inserts
- quiet-running operation due to 16 kHz switching frequency
- serial interface
- integrated chopper electronics
- state-of-the-art IGBT components
- operation by removable control unit

Comprehensive protective functions facilitate simple commissioning and problem-free, reliable operation of the unit. Rapid elimination of faults is supported by an automatic fault diagnosis facility, thus guaranteeing high reliability and operating safety for the Dematik EPU/DPU-V-H frequency inverter range.

Delivery form

As standard, frequency inverters of the Dematik EPU/DPU-V-H range are supplied as the basic unit with the PLC interface. The units can also be supplied with an optional control unit and an InterBus-S interface.

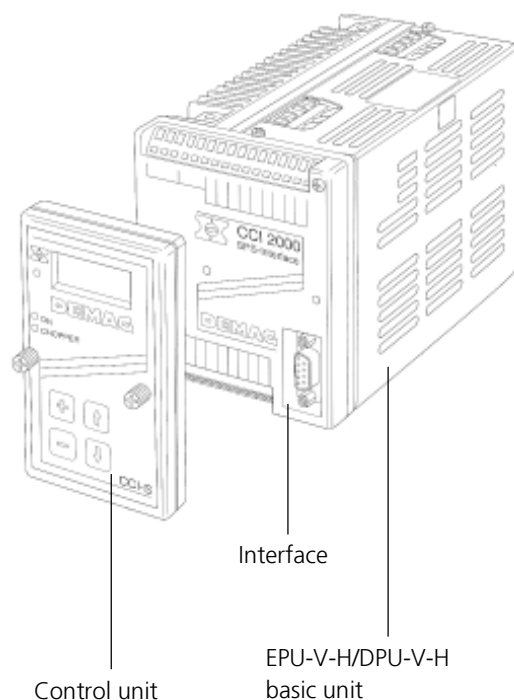
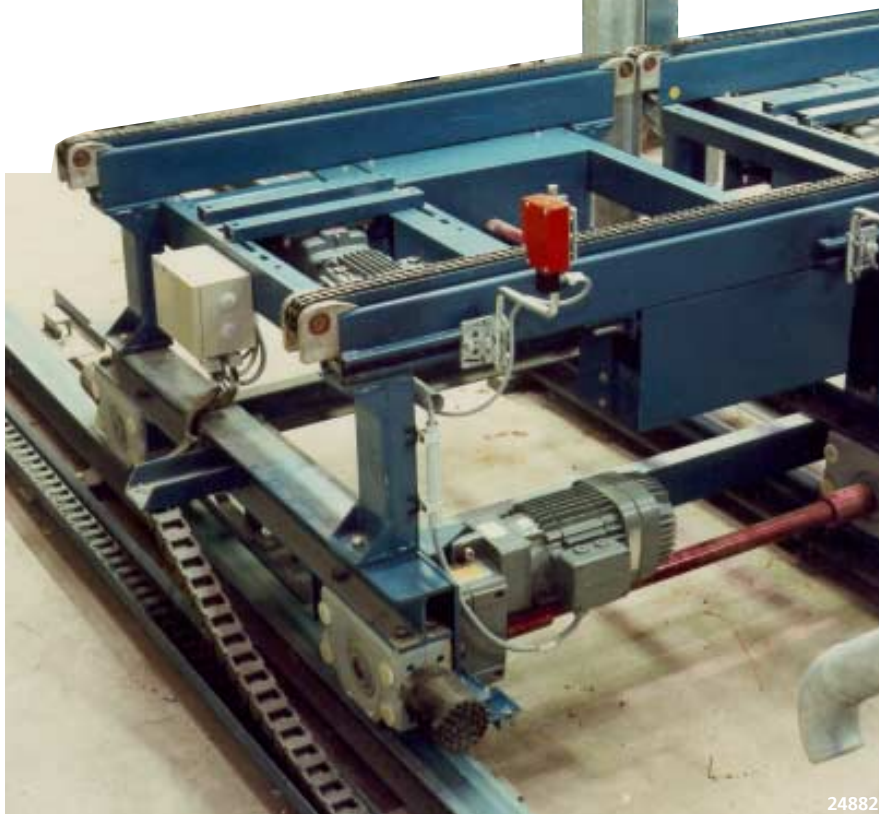

Practical and cost effective: interfaces and control unit

InterBus-S interface

Dematik EPU/DPU-V-H frequency inverters can be connected to this field bus system via the InterBus-S interface, with support provided for DRIVECOM profile 21. This type of connection requires little cabling and wiring: simply connect the bus cable and apply the supply voltage.

Connections

- 1 plug connector for the incoming bus
- 1 socket connector for the outgoing bus

Features and advantages

- simple installation
- low cabling and wiring costs



PLC interface

The PLC interface enables you to specify analog setpoint values via a PLC. In addition to the 24 V control inputs, it also features two freely programmable relay outputs and a serial interface. All control connections including the interface are insulated.

Connections

- 7 PLC compatible control inputs
- 2 relay outputs as changeover contacts
- 1 serial interface
- 1 pulse generator connection

Features and advantages

- simple installation
- low cabling and wiring costs
- configurable outputs

Control unit

The optional control unit can be plugged onto each of the two interfaces for direct programming of Dematik EPU/DPU-V-H frequency inverters.

The two-line LC display provides legible cleartext information in various languages or in coded form.

Features and advantages

- simple menu operation
- language can be selected by the user – German, English, French, Spanish
- parameters can be saved in the control unit



Distinct type designations

Dematik EPU/DPU-V-H frequency inverter type designations define all important features and data:

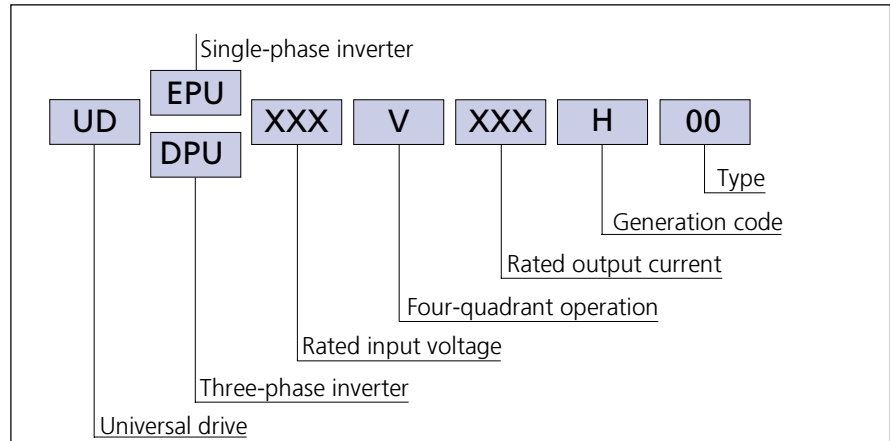

And for larger outputs: Dematik DPU-V-E frequency inverters



High rates of acceleration, high braking capacity and large load reserves in daily operation – tasks to be performed by state-of-the-art variable speed drives. Dematik DPU-V-E frequency inverters for AC motors up to 75 kW and supply voltages of 380 to 500 V meet these demanding requirements. And our load-dependent speed control, the Demag ProHub version, is available for hoist applications.



The main features and advantages of the Dematik DPU-V-E range include:

- integrated output filter
- high performance, integrated brake chopper
- fully digital unit
- electrical isolation
- IGBT power stage
- selectable clock frequencies from 1 to 16 kHz
- dynamic line voltage tolerance
- monitoring and protection functions
- PLC compatibility
- field bus connection via optional InterBus-S card

Technical data and further options

| Basisgerät | | | | |
|---------------|--|---|---------------|---------------------|
| Type | UD-EPU/DPU-... | 230V 003H | 230V 005H | 400V 004H |
| | | CCI-2101 ¹⁾ | CCI-2102 | CCI-2303 |
| Output | Rated output | 1200 VA | 2000 VA | 2700 VA |
| | Recom. motor output | 0.12 – 0.75 kW | 0.75 – 1.1 kW | 1.1 – 1.5 kW |
| | Rated current | 3.5 eff. | 5.6 eff. | 4.2 eff. |
| | Peak current ²⁾ | | | |
| | Frequency range | 0 Hz – 544 Hz | | |
| | Switching frequency | 8 kHz, 16 kHz (adjustable) | | |
| | Efficiency | 93 % | | |
| Brake chopper | Transistor and measuring circuit | $I_{max} = 2 \text{ A für } 10 \text{ S}^3)$ | | |
| | Ext. resistance (minimal) | 200 V | | 330 V |
| Line input | Voltage | 230 V ± 10 % AC | | 400 V ± 10 % AC |
| | Frequency | 47 Hz – 63 Hz | | |
| | Fusing | ext. 8 AT | ext. 16 AT | ext. 10 AT |
| Environment | Temperature | 0 – 40 °C | | |
| | Power loss | 55 W | 85 W | 110 W |
| | Installation height | up to 1000 m above sea level | | |
| Protection | Overcurrent | Current limitation for each bridge transistor adjustable I ² T limitation 2-stage limit current cut-off | | |
| | Overtemperature | Switch-off at overtemperature | | |
| | Voltage monitoring | Switch-off at overvoltage and undervoltage; frequency boost at overvoltage | | |
| Parameters | Characteristics | U/f: linear or 3 characteristic points, programmable | | |
| | Accel./braking ramp | separately programmable; 0.1 – 544 Hz/s | | |
| | Min./max. frequency | programmable | | |
| | Starting voltage (boost) | 0 – 42 V | 0 – 42 V | 0 – 68 V |
| Mech. design | Enclosure | IP 20 | | |
| | Cooling | matched cooling system | | integrated fan |
| | Dimensions (L x W x H) | Inverter module: 186 x 95 x 110 mm | | |
| | Mounting | Mounted on hat rail for installation in switchgear cabinet with bracket for 19" insert with bracket for wall mounting | | |
| Norms | DIN VDE 0160, VDE 0106; IEC 801; EN 50 081; EN 50 082; EN 55 011 | | | |

| PLC interface | | | | |
|--------------------------------------|------------------------|---|--|-----------------------|
| Control inputs (Level: 13 – 30 V) | Setpoint value analog | 0 – 10 V 0 – 20 mA | | 2 – 10 V 4 – 20 mA |
| | Setpoint value digital | SIO 20 mA – passive current loop; 6 digital PLC inputs 24 V; control unit | | |
| | Enable | PLC input 24 V | | |
| | Electrical design | digital, PLC compatible | | |
| | Pulse generator | $f_{max} = 10 \text{ kHz}$ | | |
| Control outputs | Voltage source | 24 V / 80 mA for PLC control inputs 10 V / 4 mA for analog input 5 V / 5 mA for pulse generator | | |
| | Speed display | 0 – 5 V DC | | |
| | Control outputs | 2 relays, 1 changeover unit each: max. 250 V / max. 2 A, 12 configurable functions | | |

InterBus-S-Interface

Features supports DRIVECOM profile 21 connection to the peripheral bus

- ¹⁾ other voltages on request
²⁾ for 60 s, every 10 min
³⁾ I = 0,5 A in continuous duty

Control unit

Optional features multi-lingual display; for setting, saving and transferring parameters

Further options

Extension cable for the control unit, 1 m long
 Braking resistor 220 V or 330 Ω
 Radio interference suppression filter according to EN 55 011 (limit curve B)

Demag Cranes & Components GmbH

P.O. Box 67 · D-58286 Wetter

Telephone (+49/2335) 92-0

Telefax (+49/2335) 927676

www.demagcranes.com