



ECODRIVE DKC03.1 Drive Controller

Project Planning Manual

DOK-ECODRV-DKC03.1****-PRJ4-EN-P



Title	ECODRIVE DKC03.1 Drive Controller
Type of documentation	Project Planning Manual
Type	DOK-ECODRV-DKC03.1****-PRJ4-EN-P
Internal file reference	<ul style="list-style-type: none"> 209-0069-4392-04

Revision order

Documentation description past editions	Date	Comments
DOK-ECODRV-DKC03.1****-PRJ1-EN-P	Sept. '97	1st edition
DOK-ECODRV-DKC03.1****-PRJ2-EN-P	Nov. '97	new edition
DOK-ECODRV-DKC03.1****-PRJ3-EN-P	Dec. '97	new edition
DOK-ECODRV-DKC03.1****-PRJ4-EN-P	Feb. '98	new edition

Copyright © INDRAMAT GmbH, 1996

Distribution and reproduction of this documentation as well as processing and communicating its contents without the expressed written consent of the publisher are prohibited. Violators are liable for damages incurred. All rights reserved in the event a patent is granted or a utility model is registered. (DIN 34-1)

Published by INDRAMAT GmbH • Bgm.-Dr.-Nebel-Str. 2 • 97816 Lohr/Main, Germany
Phone +49 (9352) 40-0 • Tx 689421 • Fax +49 (9352) 40-4885
Dept. ENA (HB)

Validity The contents of this documentation and the availability of the products described herein are subject to change.

The purpose of this documentation

It supplies information:

- for planning the mechanical control cabinet construction
- for planning the electrical control cabinet construction
- for the logistical handling of the equipment
- preparing the necessary equipment for startup operation

Supplementary documentation

"ECODRIVE Servo drives DKC with MKD"

- Selection Data -

DOK-ECODRV-DKC+MKD****-AUS1-EN-P

for selecting the motor/drive combination.

"ECODRIVE Digital Servomotors MKD"

- Project Planning Manual -

DOK-MOTOR*-MKD*****-PRJ2-EN-P

for a detailed description of the servomotors and for selecting the required cables.

"ECODRIVE DKC03.1 Drive"

- Function Description -

DOK-ECODRV-PDP-XXXXX**-FKB1-EN-P

for testing and selecting functions.

"EMC in Drive and Control Systems"

- Project Planning Manual -

DOK-GENERL-EMV*****-PRJ1-EN-P

for planning and installing drive systems in compliance with EMC requirements (EMC = electromagnetic compatibility).

Notes

Table of Contents

1 Introducing the System	1-1
1.1 Application features.....	1-1
1.2 An overview of the functions	1-1
2 Safety Instructions for Electrical Drives	2-1
2.1 General	2-1
2.2 Protection against contact with electrical parts	2-2
2.3 Protection against electrical shock from protective low voltage (PELV)	2-3
2.4 Protection against dangerous movements.....	2-4
2.5 Protection against magnetic and electromagnetic fields during operation and assembly	2-6
2.6 Protection during handling and assembly	2-7
2.7 Using batteries safely.....	2-7
3 Selecting the Components	3-1
3.1 Overview of the required components	3-1
3.2 Selection procedure	3-2
3.3 Compiling the required data	3-3
4 ECODRIVE DKC Drives	4-1
4.1 Hardware.....	4-1
Dimensional sheet and installation dimensions	4-1
Technical specifications	4-2
Type code and rating plate.....	4-5
4.2 Firmware	4-6
4.3 An overview of the electrical connections	4-7
Front view with connecting terminals	4-7
Overall connection diagram	4-8
4.4 Electrical connection on the connection terminal strips	4-9
Serial interface X1	4-9
X3 Control inputs and analog outputs	4-13
X4 Connections for the control circuit	4-14
X5, X6, X7 Motor connections.....	4-15
X9 DC Bus	4-15
X10 PROFIBUS-DP Connection	4-15

5 BZM Auxiliary Bleeder Module	5-1
5.1 Dimensioning the components for regeneration	5-1
5.2 Dimensional sheet and installation dimensions	5-5
5.3 Technical specifications	5-6
5.4 Front view.....	5-6
5.5 Electrical connection	5-7
5.6 Type code and rating plate.....	5-7
6 CZM Auxiliary Capacitance Module	6-1
6.1 Dimensioning	6-1
6.2 Dimensional sheet and installation dimensions	6-3
6.3 Front view.....	6-4
6.4 Electrical connection	6-4
6.5 Type codes and rating plate.....	6-5
7 DC24V NTM Power Supplies	7-1
7.1 Application recommendation.....	7-1
7.2 Technical specifications	7-1
7.3 Dimensional sheets and installation dimensions	7-2
7.4 Front view.....	7-2
7.5 Electrical connection	7-3
7.6 Type code	7-4
8 NFD / NFE Mains Filter	8-1
8.1 Selection	8-1
8.2 Dimensional sheet and installation dimensions	8-2
8.3 Electrical connection	8-3
8.4 Mains Filter for DC24V NTM Power Supplies.....	8-4
8.5 Type code	8-5
9 DST / DLT Transformers	9-1
9.1 Selection	9-1
9.2 Autotransformers for DKC**.*-040-7-FW	9-1
9.3 Electrical connections of the DKC using a transformer	9-4
9.4 Type code	9-4
10 Planning the Control cabinet Construction	10-1
10.1 Notes on installing the control cabinet	10-1
Power dissipation	10-1
10.2 Using heat-exchanger units in the control cabinets	10-2

11 Power Connection	11-1
11.1 Direct mains connection.....	11-1
11.2 Mains contactor/fuse protection	11-2
Calculating the phase current at the mains.....	11-2
Selecting fuse protection Q1 and mains contactor K1	11-3
11.3 Control circuit to the power connection.....	11-4
11.4 Protection against indirect contact.....	11-6
12 Preparing for Initial Startup	12-1
Required equipment.....	12-1
13 Delivery Condition of the Drive Components	13-1
Packaging	13-1
Shipping documents.....	13-1
Identification of the components	13-1
14 Index	14-1

Notes

1 Introducing the System

1.1 Application features

A drive system implementing ECODRIVE drive controllers is the most cost-effective solution offering highest functionality for almost any area of application in which translatory or rotary motions are to be automated.

Outstanding performance data, an extensive range of functions as well as the excellent price to performance ratio represent the salient features of this drive system.

Product features in terms of the technical applications are:

- universal implementation
- ease of operation
- digital drive concept
- highly dynamic operation
- cost-effective direct connections to the power outlet
- software limits for travel range
- absolute or incremental position detection
- holding brake controls are integrated
- increased operating safety
- adjustable error reactions
- easy startup operation

1.2 An overview of the functions

The DKC is used as a servo drive with integrated position control.

The connection between the DKC03.1 drive controller and the higher-level control is realised with a PROFIBUS-DP.

Servo drive with integrated position control and PROFIBUS-DP Interface

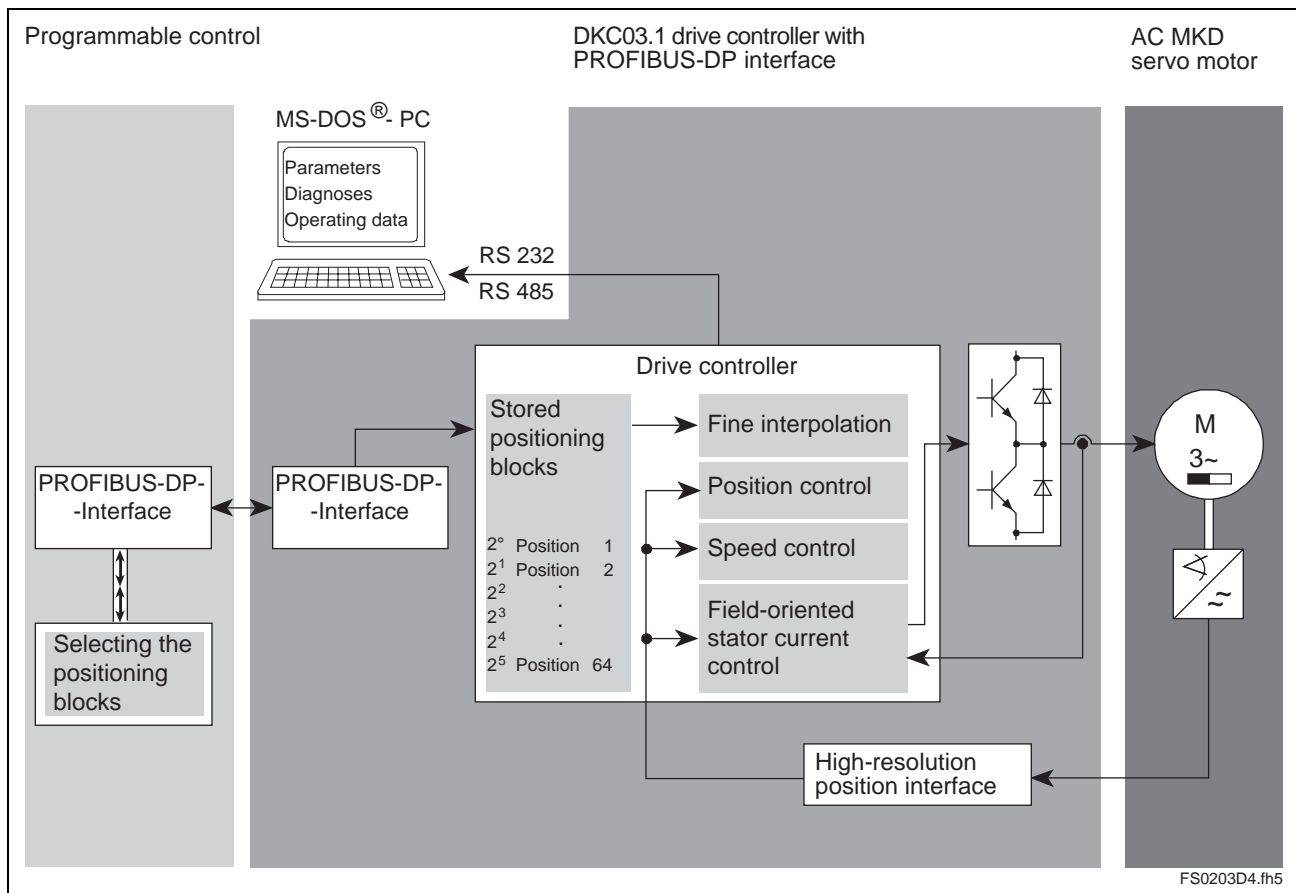

Fig. 1-1: Servo drive with integrated position control and PROFIBUS-DP interface

- Up to 64 positioning blocks can be stored in the drive. They can be selected from a PLC using the PROFIBUS-DP interface. The positioning block is executed independently.
- Mechanical translatory elements such as gear ratios or infeed constants are adapted in the drive.
- All position, speed and acceleration data can be weighted independent of axis kinematics in a rotary or translatory manner.
- A drive-internal referencing procedure is available for creating a reference dimension.
- The axis can be moved with the jogging function during setup mode.
- The positioning speed can be influenced via the feedrate override.
- Travel zone end switch inputs and parametric axis limit values are available for limiting the travel range.
- The drive status can be established via status outputs.
- The drive is equipped with extensive diagnoses capabilities.
- Various travel range modes can be parameterized for the positioning blocks.
- The positioning blocks are processed depending on the sensor signals.
- Parameter handling is easy using of the startup program Drive-Top, and the serial interfaces RS-232 or RS-485.

2 Safety Instructions for Electrical Drives

Please read the following instructions carefully before initial startup. These safety instructions must be observed.

If the product is transferred to a third-party, the safety instructions must be included.



WARNING

Improper use of this equipment and non-compliance with the safety instructions provided here can result in damage, personal injury or, in extreme cases, death.

2.1 General

INDRAMAT GmbH is not liable for any damages resulting from failure to observe the safety instructions in this documentation.

- Documentation in the relevant language should be obtained before initial startup if the language in this documentation is not perfectly understood.
- Proper transport, correct storage, assembly, and installation as well as care in operation and maintenance are prerequisites for optimum and safe operation of this unit.
- Qualified personnel:
Only qualified personnel should be permitted to operate this unit or work in its immediate vicinity. Personnel is considered qualified if it has sufficient knowledge of the assembly, installation, and operation of the product as well as all warnings and precautionary measures in this documentation.

Furthermore, personnel should be trained, instructed or authorised to switch electrical circuits on and off and to ground and mark them in accordance with the requirements of safety engineering. Personnel should possess adequate safety equipment and be trained in first aid.

- Use only spare parts approved by the manufacturer.
- All safety regulations and requirements for the specific application must be followed.
- The equipment is designed to be installed in machines for commercial use.
- Startup operation is only permitted after it has been ascertained that the machine in which the products are installed complies with the national safety regulations and safety instructions. European countries: EC Directive 89/392/EEC (Machine Guideline)
- Operation is only permitted if the national EMC regulations for the specific application have been met. European countries: EC Directive 89/336/ECC (EMC Guideline)

The instructions for installation in accordance with EMC requirements can be found in the documentation "EMC Drive and Control Systems."

The responsibility for adherence to the limiting values required by national regulations lies with the manufacturer of the equipment or machine.

- Technical specifications as well as the connection and installation requirements can be found in the product documentation and must be observed under all circumstances.

2.2 Protection against contact with electrical parts

Note: Only relevant for equipment and drive components with voltages over 50 volts.

Touching parts with voltages in excess of 50 volts is dangerous. When operating electrical equipment, certain components have dangerous voltages applied to them.



DANGER

High Voltage!

Danger! May cause serious injury or death!

- ⇒ Observe general installation and safety regulations when working on electrical power installations.
 - ⇒ Before switching on power, be sure that the protective conductor is permanently connected to all electrical units according to the connection diagram.
 - ⇒ At no time may electrical equipment be operated if the protective conductor is not permanently connected to the intended points, even for brief measurements or tests.
 - ⇒ Disconnect the unit from the mains or the voltage source before accessing parts with voltages greater than 50 volts. Secure the equipment from being switched on again inadvertently.
 - ⇒ Wait 5 minutes after switching off power to allow capacitors to discharge before beginning work. Measure the voltage of the capacitors before beginning work to prevent injuries caused by touching the equipment.
 - ⇒ Never touch the electrical connection points of a component while power is turned on.
 - ⇒ Cover live parts properly before switching the equipment to prevent contact with them. Use only the provided covers as protection.
 - ⇒ A current operated ELCB device must not be used for AC drives! Indirect contact must be ensured by other means, for example, by using an overcurrent protection device which complies to the relevant standards. European countries: in accordance with EN 50178/1994, section 5.3.2.3
 - ⇒ Installation equipment must be secured against indirect contact with electrical parts by enclosing them in a housing such as a control cabinet. European countries: in accordance with EN 50178/1994, section 5.3.2.3
-

**High discharge current!**

Danger! May cause serious injury or death!

- ⇒ All units and the motors must be connected to a grounding point with the protective conductor or must be grounded themselves before switching on power.
 - ⇒ The discharge current is greater than 3.5 mA. A permanent connection to the supply system is therefore required for all equipment. European countries: according to EN 50178/1994, section 5.3.2.3; USA: _____
European countries (EN 50178/1994, section 5.3.2.3).
 - ⇒ Before startup operation, always earth or connect the protective conductor, even for testing purposes. Otherwise, high voltages may be present at the housing.
-

2.3 Protection against electrical shock from protective low voltage (PELV)

All connections and terminals on INDRAMAT products with voltages ranging from 5 to 50 volts are protective low voltages designed in accordance with the following standards:

- international: IEC 364-4-411.1.5
- European countries in the EC: EN 50178/1994, section 5.2.8.1

**High electrical voltages due to incorrect connections!**

Danger! May cause serious injury or death!

- ⇒ Only equipment, electrical components and cables of the low protective type (PELV = Protective Extra Low Voltage) may be connected to connectors and terminals with voltages from 0 to 5 volts
 - ⇒ Only connect voltages and electrical circuits safely isolated from dangerous voltages. Safe isolation can be achieved, for example, by using an isolating transformer, a reliable optoelectronic coupler or during battery operation.
-

2.4 Protection against dangerous movements

Dangerous movements are caused if the connected motors are interfaced incorrectly.

There are various causes of dangerous movements:

- faulty wiring or cable connections
- equipment is not being operated correctly
- Errors in the measured-value transmitter and primary detector.
- components are defective
- software errors

These errors can occur directly after the equipment was switched on or after an unspecified time of operation.

The monitoring circuits in the drive components practically eliminates faulty operation in the connected drives. However, personnel safety requires that additional measures be taken to ensure correct operation. Faulty drive motions which are influenced by the type of control and the operating status cannot be entirely excluded until the installed monitors take effect.

**Dangerous movements!**

Danger! May cause equipment damage, personal injury or death!

⇒ Personal safety must be ensured by higher-level, plant-dependent monitoring or precautionary measures for the reasons listed above. These are provided by the plant manufacturer according to the specific conditions of the plant based on a danger and malfunction analysis. The safety regulations in effect for the plant are included herein.

Avoiding accidents:

- ⇒ Keep clear of the machine's movement area. Possible measures to be taken to prevent unauthorised access by persons:
 - protective fences
 - protective railings
 - protective coverings
 - light barrier
- ⇒ Fences and covers should be strong enough to withstand the maximum possible momentum.
- ⇒ Mount the emergency stop switch at an easily accessible place in the immediate vicinity. Verify that the emergency stop switch works before starting operation.
- ⇒ Isolate the drive power connection by means of an emergency stop circuit or use a starting lock-out to prevent unintentional startup.
- ⇒ Make sure that the drives have been shut down before accessing or entering the danger zone.
- ⇒ Disable electrical power to the equipment using a master switch and secure against the unit being switched on inadvertently for:
 - maintenance and repair work
 - equipment cleaning
 - long periods of non-operation
- ⇒ Avoid operating high-frequency, remote control, and radio equipment near electrical equipment and their supply leads. If the use of such equipment cannot be avoided, verify that the system and plant are in perfect working order in all working situations before initial startup operation. If necessary, the plant must undergo special EMC testing.

2.5 Protection against magnetic and electromagnetic fields during operation and assembly

Magnetic and electromagnetic fields near live conductors and permanent magnets pose a serious health hazard for persons with pacemakers, metal implants and hearing aids.



WARNING

Health hazard for persons with pacemakers, metal implants and hearing aids near electrical equipment.

⇒ Persons with pacemakers and metal implants must not be permitted access to the following areas:

- Areas in which electrical equipment and parts are mounted, operated or put into operation.
- Areas in which motor parts with permanent magnets are stored, repaired or mounted.

⇒ If it becomes necessary for a person with a pacemaker to enter such an area, this must be approved by a physician beforehand.

Implanted pacemakers or those to be implanted exhibit varying degrees of resistance to interference, making it impossible to establish any general guidelines.

⇒ Persons with metal implants or metal splinters as well as hearing aids should consult a physician before entering such areas since they represent a health hazard.

2.6 Protection during handling and assembly

Handling or assembling drive components improperly may lead to personal injury.



CAUTION

Risk of injury due to improper handling!

Bodily injury may be caused by crushing, shearing, cutting and pounding.

- ⇒ Observe general installation and safety regulations when working on electrical installations.
- ⇒ Use suitable mounting and transport equipment.
- ⇒ Take precautions to prevent pinching and crushing.
- ⇒ Use only suitable tools. Use special tools as prescribed.
- ⇒ Employ lifting devices and tools according to the manufacturers' instructions.
- ⇒ If necessary, use suitable protective equipment (for example goggles, safety shoes, protective gloves).
- ⇒ Do not stand under suspended loads.
- ⇒ Remove any liquids on the floor immediately to prevent slipping.

2.7 Using batteries safely

Batteries consist of reactive chemicals in a solid case. Improper use can therefore lead to injuries or equipment damage.



CAUTION

Risk of injury due to improper handling!

- ⇒ Do not attempt to reactivate empty batteries by heating them or by any other means (danger of explosion or corrosion).
- ⇒ Do not recharge batteries because they may leak or explode.
- ⇒ Do not dispose of batteries by incinerating them.
- ⇒ Do not attempt to disassemble batteries.
- ⇒ Do not damage the electrical components installed in the equipment.

Note: Environmental protection and disposal! The batteries contained in the product are considered hazardous material for land, sea, and air transport according to legal regulations. Dispose used batteries separately from other waste. Observe the national regulations in the country of installation.

Notes

3 Selecting the Components

3.1 Overview of the required components

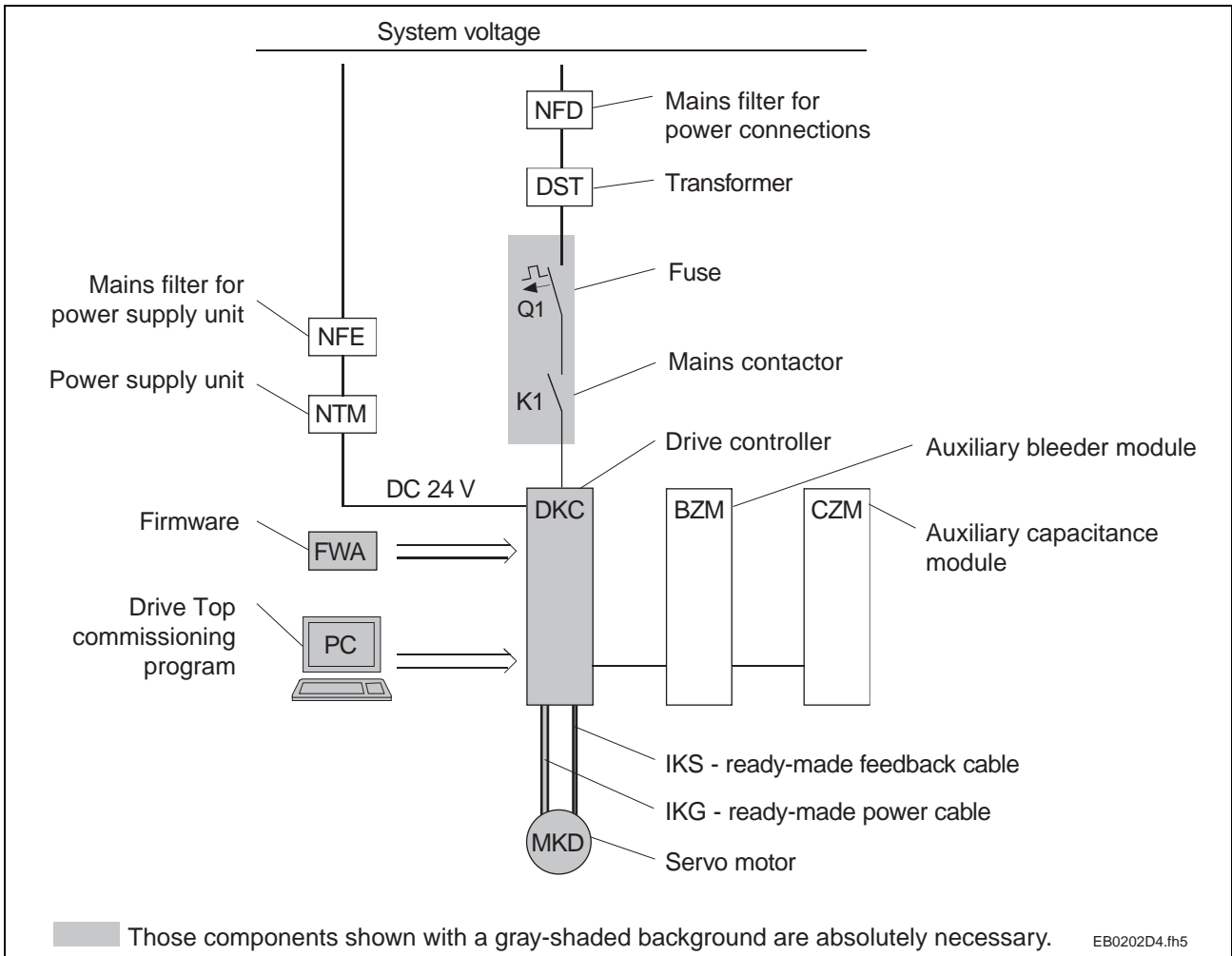

Fig. 3-1: Overview of the required components

3.2 Selection procedure

- Dimensioning and selecting the servo drive**
- ⇒ Dimension the drive according to how it is to be used. A documentation for this is presently being prepared.
 - ⇒ Select motor/drive combination (DKC + MKD) using the "Selection Data" documentation (see pg. 3, supplementary documentation).
- Compiling the required data**
- ⇒ Enter the values obtained from dimensioning and selecting the drives in table Fig. 3-2.
 - ⇒ Calculate the continuous regenerative power according to the specifications in Chapter 5, and enter them in table Fig. 3-2.
- Selecting the required components**
- ⇒ For DKC03.1**** use firmware "FWA-ECODRV-PDP-03VRS-MS".
 - ⇒ Select ready-made cables for a DKC and MKD by using the documentation MKD motors - Project Planning Manual (see pg. 3 of supplementary documentation).
 - ⇒ Select fuse protection Q1 (see Chapter 11).
 - ⇒ Select fuse protection Q1 (see Chapter 11).
- Determining components which may be additionally required**
- ⇒ Check the rated mains voltage. If, in the case of the DKC**.*-040-7, the rated mains voltage exceeds 3xAC (380-460)V (10%, then select a DST transformer (see Chapter 9).
 - ⇒ Check the DC24V control voltage supply for the DKC. If DC24 Volt \pm 20 % is not available, then select a suitable NTM (see Chapter 7).
 - ⇒ Check the DC24V voltage for the motor holding brake. If DC24 Volt \pm 10 % is not available, then select a suitable NTM (see Chapter 7).
 - ⇒ Check the continuous regenerative power. If it exceeds 0.15 kW, then consider option with BZM auxiliary bleeder module (see Chapter 5).
 - ⇒ Check the continuous regenerative peak power. If it exceeds 10 kW, then consider option with BZM auxiliary bleeder module (see Chapter 5).
 - ⇒ If the continuous regenerative power exceeds approx. 0.1 kW and the drive system energy content is less than 200W, using an auxiliary module CZM can be economical. This makes it possible to reduce the dissipated energy for the control cabinet by an amount equal to the continuous regenerative power (see Chapter 6).
 - ⇒ Check the EMC conditions. INDRAMAT recommends the use of NFD or NFE mains filters to maintain EMC values (see Chapter 8).

3.3 Compiling the required data

Designation	Symbol	Values/Units
Effective load torque	M_{EFF} in Nm
Acceleration torque	M_{ACC} in Nm
Operating torque	M_{BEARB} in Nm
Motor speed used	n_{NUTZ} in min^{-1}
Load moment of inertia	J_{LAST} in kgm^2
Maximum rotary energy in the mechanical system (emergency stop)	$W_{ROT,MAX}$ in Ws
Continuous regenerative power	P_{RD} in kW
Continuous torque at standstill	M_{DN} in Nm
Maximum torque	M_{MAX} in Nm
Short-term operation torque	M_{KB} in Nm
Maximum motor speed	n_{MAX} in min^{-1}
Required mains connection power	S_{AN} in kVA
Required rated mains voltage	U_N in V
Motor/controller combination		DKC..... MKD.....
Motor moment of inertia	J_M in kgm^2
DKC current consumption	$I_{N,DC}$	0.7 in A
Power consumed by motor holding brake (if fitted)	$I_{N,HB}$ in A

Fig. 3-2: Data required for selecting the component

Notes

4 ECODRIVE DKC Drives

4.1 Hardware

Dimensional sheet and installation dimensions

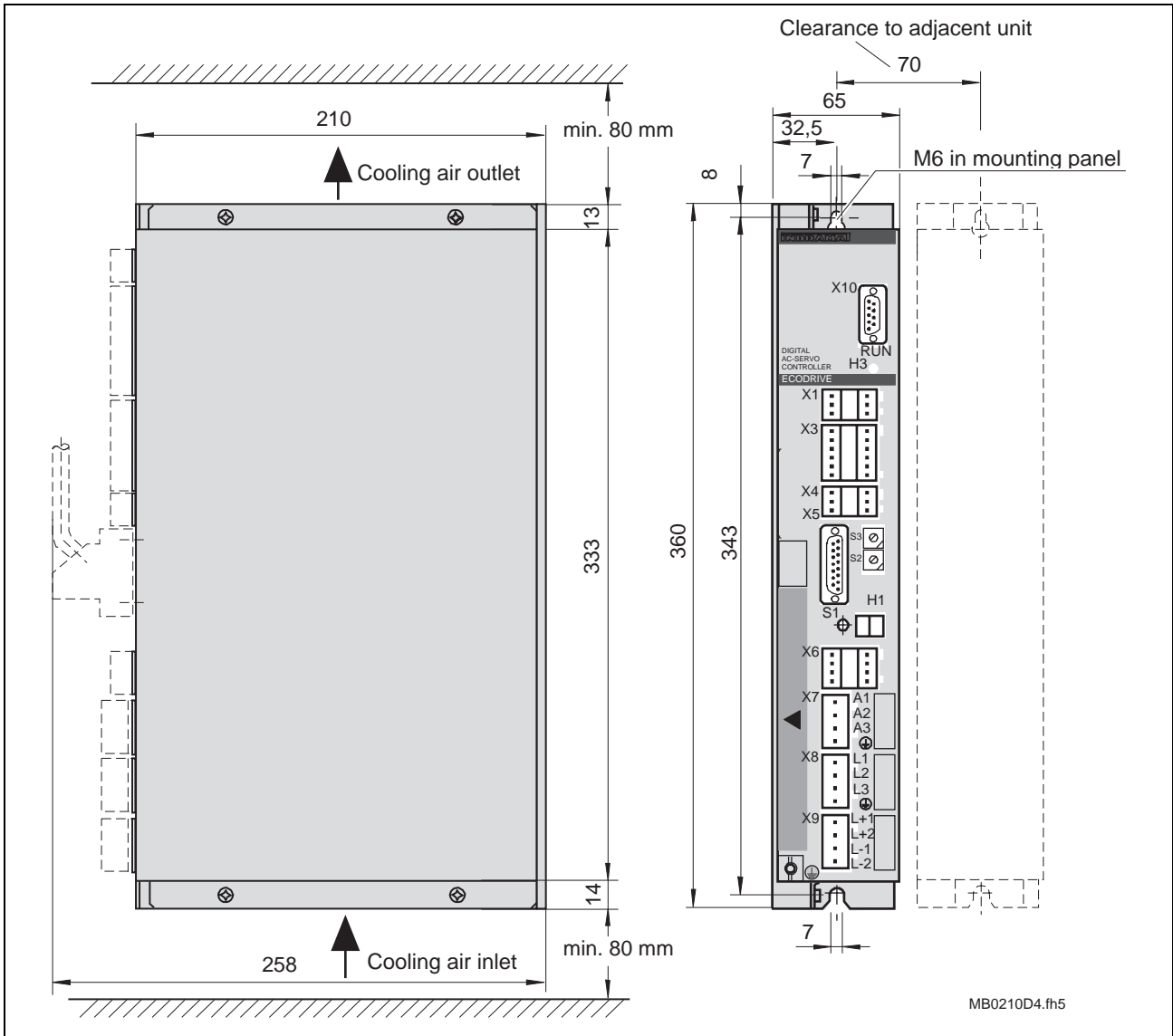

Fig. 4-1: Dimensional sheet and installation dimensions DKC03.1

Technical specifications

Mains supply / Power section

Designation	Symbol	Unit	DKC03.1-040-7-FW
Operating mode at the mains			three-phase
Mains input voltage	U_N	V	3 x AC (380 ... 480) \pm 10%
Maximum conn. voltage	S_{MAX}	kVA	4,8 ... 9
Making current	I_{EIN}	A	9 ... 12
Mains frequency	f_N	Hz	50...60
Switching frequency (selectable)	f_S	kHz	4 or 8
Continuous current at $f_S = 4$ kHz ¹⁾	I_{CONT}	A	16
Continuous current at $f_S = 8$ kHz ¹⁾	I_{CONT}	A	12,5
Rated current	I_{TYP}	A	40
Peak current	I_{PEAK}	A	40
Power dissipation, without bleeder dissipation	P_V	W	180
Peak bleeder output DKC	$P_{BM,DKC}$	kW	10 (Permissible load cycle equals 0.5 sec. on, 33 sec. off.)
Continuous bleeder output DKC	$P_{BD,DKC}$	kW	0,15
Maximum feedback energy DKC	$W_{MAX,DKC}$	kWs	5,0
Storage energy DKC	$W_{ZW,DKC}$	Ws	15
DC bus capacitance	C_{DKC}	mF	0,15
DC bus voltage ²⁾	U_{ZW}	V	DC 500...800

1) The drive data for 4 and 8 kHz switching. frequencies are listed in the document "ECODRIVE DKC servo drive" - Selection Data.
2) Value dependent on power input voltage

TB0206D4.fh5

Fig. 4-2: Technical specifications - mains supply and power section

DC24V Power supply

Designation	Symbol	Unit	DKC03.1-040-7-FW
Control voltage connection for DKC			
Input voltage	$U_{N,DC}$	V	DC (19,2 ... 28,8) V
Maximum ripple content	w	%	must not exceed the input voltage range
Current consumption	$I_{N,DC}$	A	0,7
Voltage connection for holding brake			
Input voltage	$U_{N,HB}$	V	DC (21,6 ... 26,4) V
Maximum ripple content	w	%	must not exceed the input voltage range
Current consumption	$I_{N,HB}$	A	please see MKD dokumentation

TB0208D4.fh5

Fig. 4-3: Technical specifications DC24V power supply

Additional connection of the DC24 power supply

The DKC drives should be firmly connected to the DC24V power supply; preferred method Fig. 4-4

They can also be connected to the DC24V power supply in a switchable manner Fig. 4-5

**Preferred method:
The power supply is firmly
connected to the attached DKC**

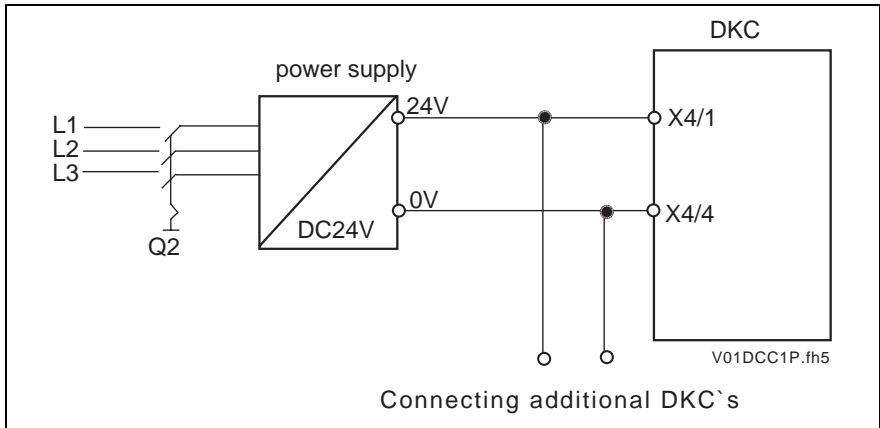

Fig. 4-4: Principle for connecting the DC24V control voltage by switching on the power supply via Q2, **preferred method**

**The power supply is connected
to the attached DKC in a
switchable manner**

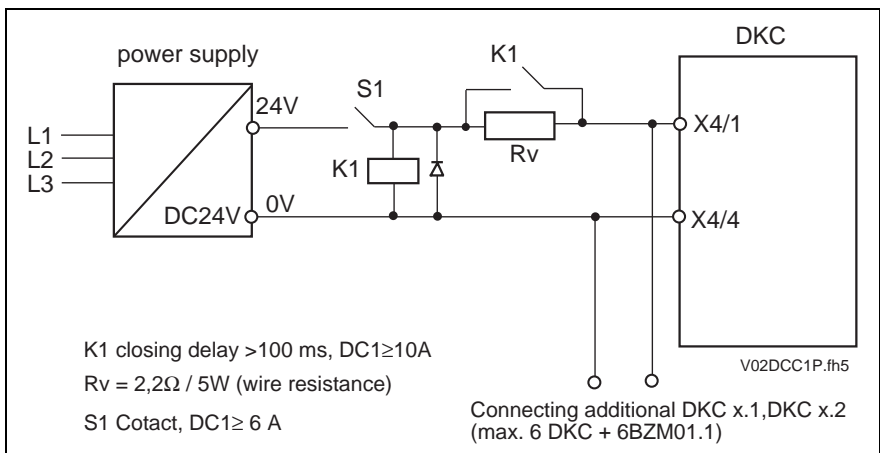

Fig. 4-5: Principle for connection the 24V via S1 with a starting current limiter

Ambient and application conditions

Ambient temperature and installation altitude

Selection data are specified for each motor/drive documentation. Please refer to the documentation "ECODRIVE Servo Drive DKC with MKD - Selection Data -

The selection data apply within the given ambient and applications conditions (see Fig. 4-7).

For different conditions, the short-term operating torque M_{KB} is diminished according to the diagrams (see Fig. 4-6). If ambient temperatures and higher installation altitudes deviate simultaneously, both load factors must be multiplied.

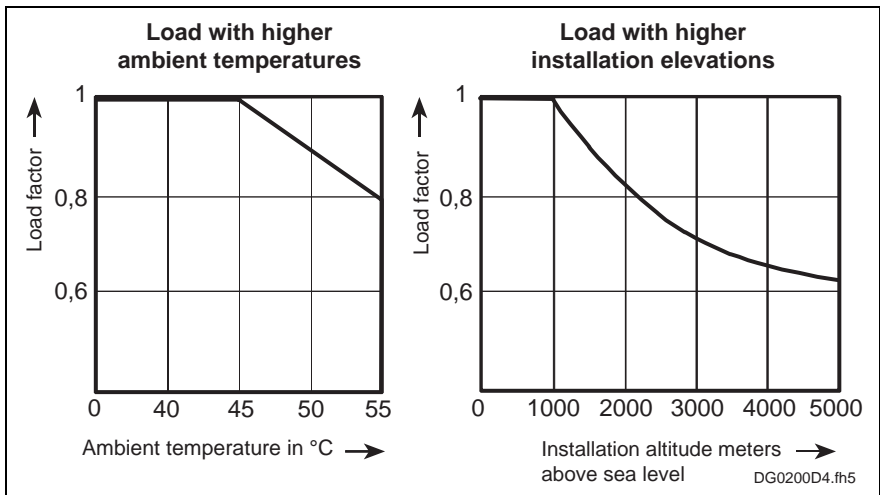

Fig. 4-6: Load utilisation dependent on ambient temperature and installation altitude

Designation	Symbol	Unit	DKC03.1-040-7-FW
Ambient and installation conditions			
Cooling the power section			internal blower cooling
Permissible ambient temperature with nominal data	T_{UM}	°C	+0...+45
Max. permissible ambient temperature with reduced nominal data	$T_{UM,MAX}$	°C	+55 The values indicated in the selection data for M_{DN} and M_{KB} drop in the range of +45 to +55°C by 2% per °C of rise in temperature.
Storage and transport temperature	T_L	°C	-30...+85
Max. installation elevation with nominal data		m	1000
Max. permissible relative humidity		%	95
Max. permissible absolute humidity		g/m ³	25
Degree of contamination			Non-conductive dirt contamination, no condensation
Protection category			IP20, as per EN 60529 = DIN VDE 0470-1-1992 (IEC 529-1989) stationary use in control cabinets
Weight	m	kg	4.4

Fig. 4-7: Ambient and application conditions

Type code and rating plate

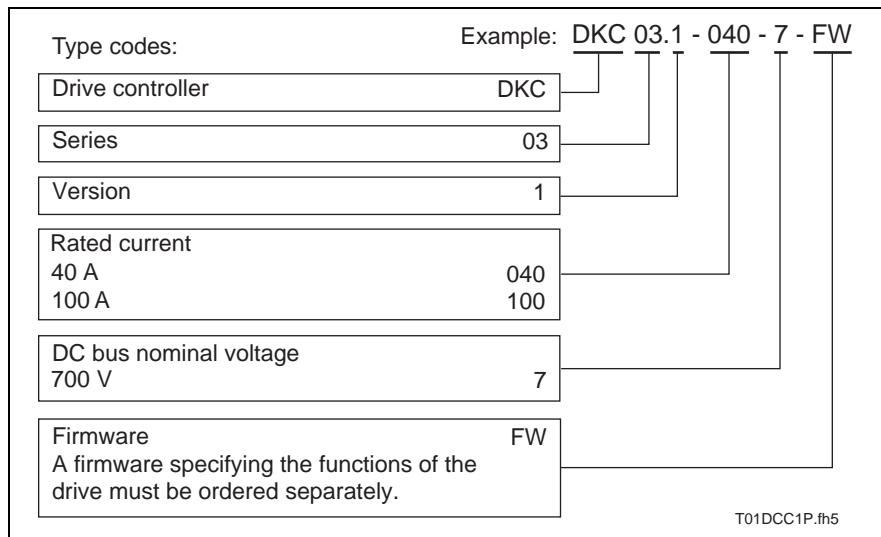

Fig. 4-8: Type code DKC

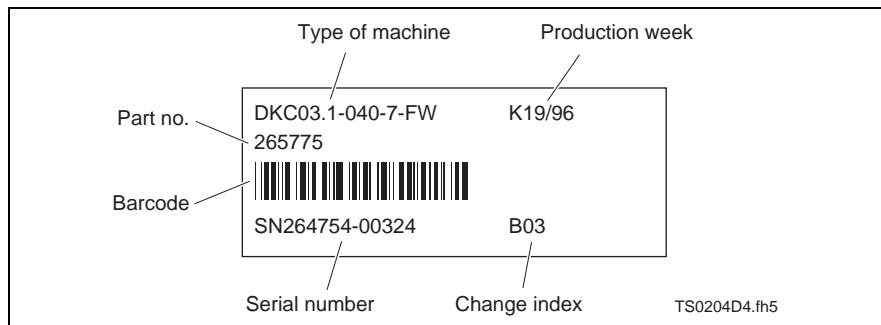

Fig. 4-9: Rating plate DKC

4.2 Firmware

The firmware integral to the drive controller determines the functional features of the ECODRIVE drive controller.

Firmware "FWA-ECODRV-PDP-03VRS-MS" is available for the DKC03.1-***.

The firmware has its own order number. This means that it is always possible to order the identical firmware version.

The firmware is continuously updated to eliminate any possible errors without altering the functionality. It is identified in the type code as the firmware release version.

If newer functions are added, then the index of the firmware version is incremented (see type codes).

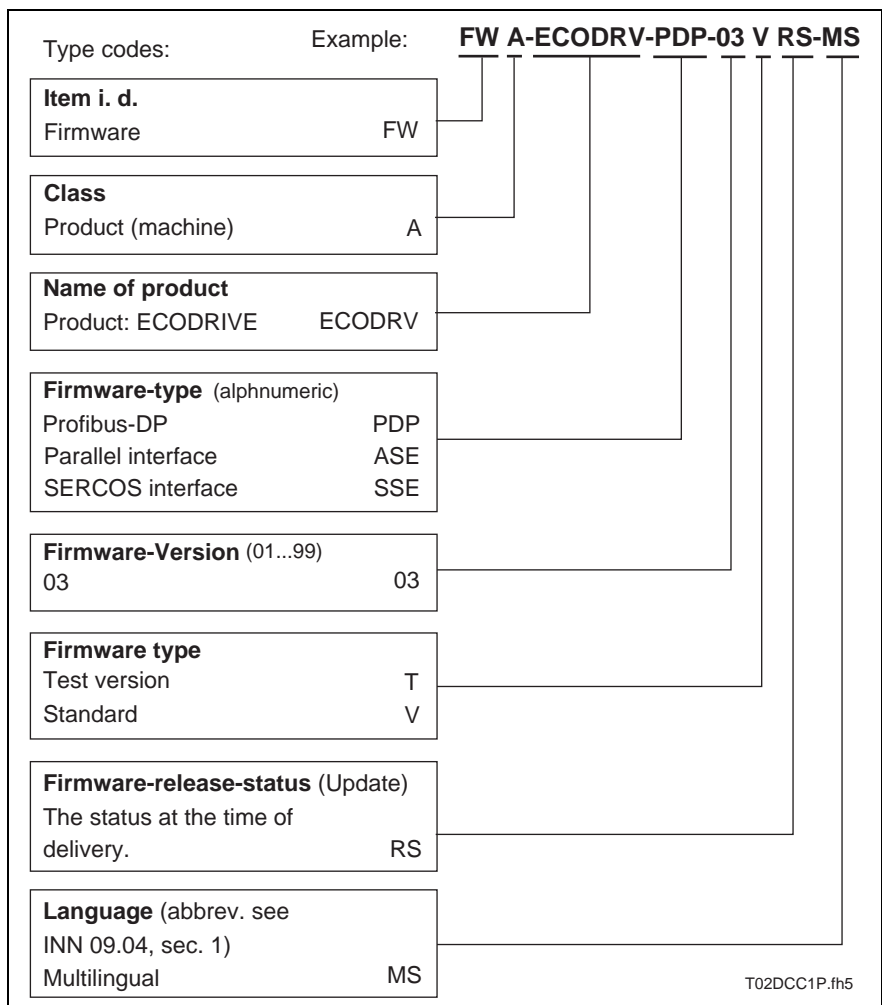

Fig. 4-10: Type code firmware ECODRIVE

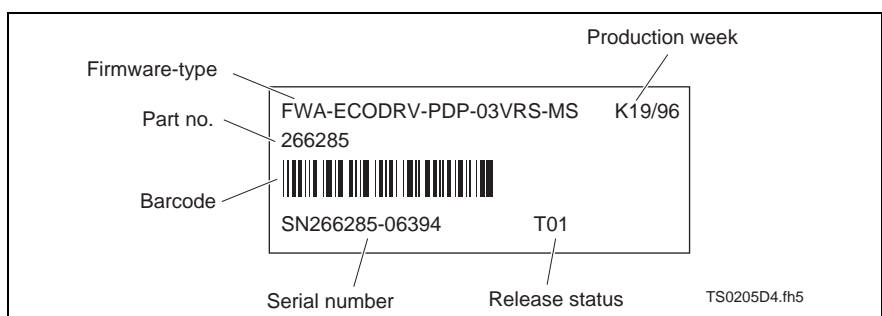

Fig. 4-11: Rating plate firmware

4.3 An overview of the electrical connections

Front view with connecting terminals

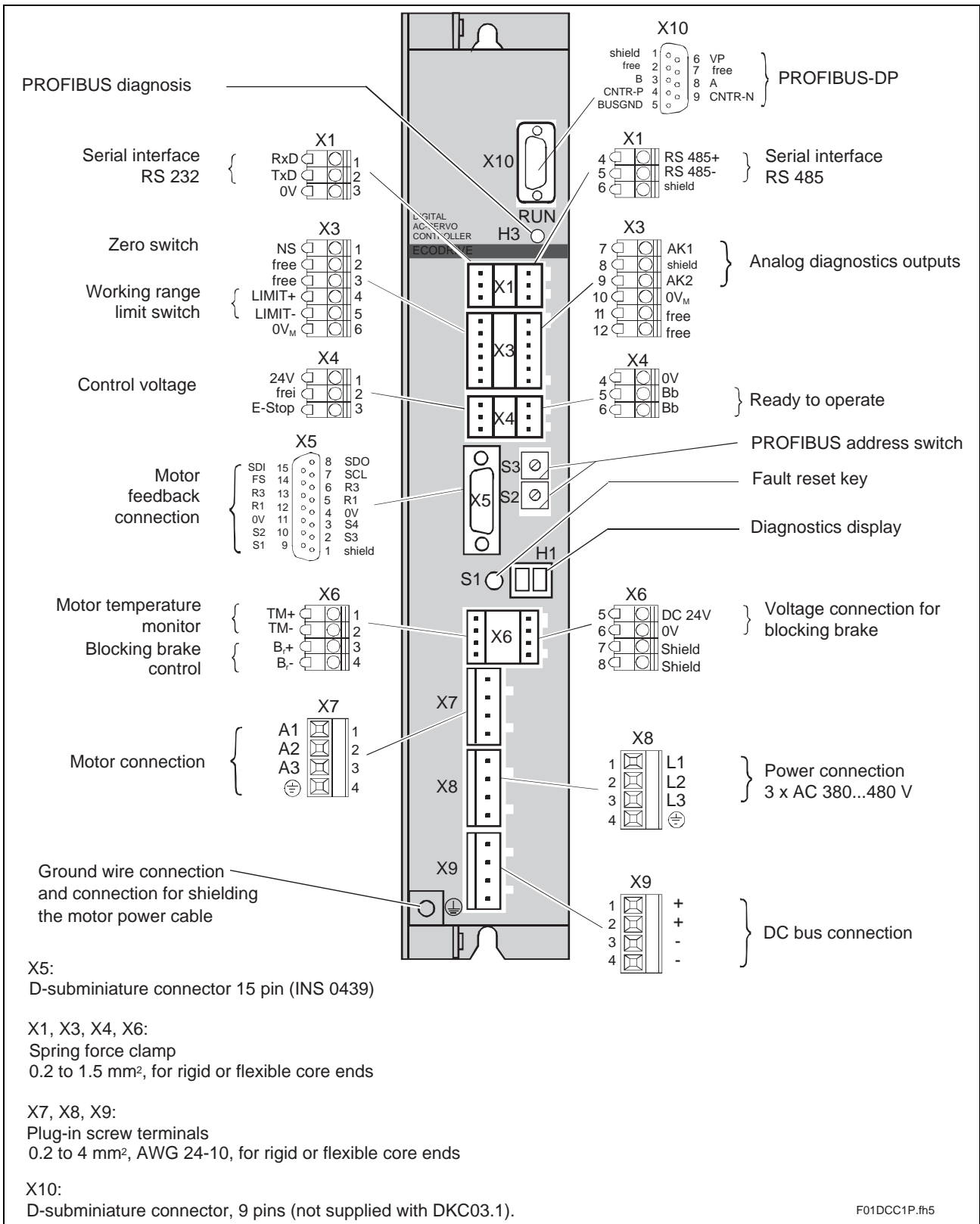

Fig. 4-12: Front view DKC with connection terminals

Overall connection diagram

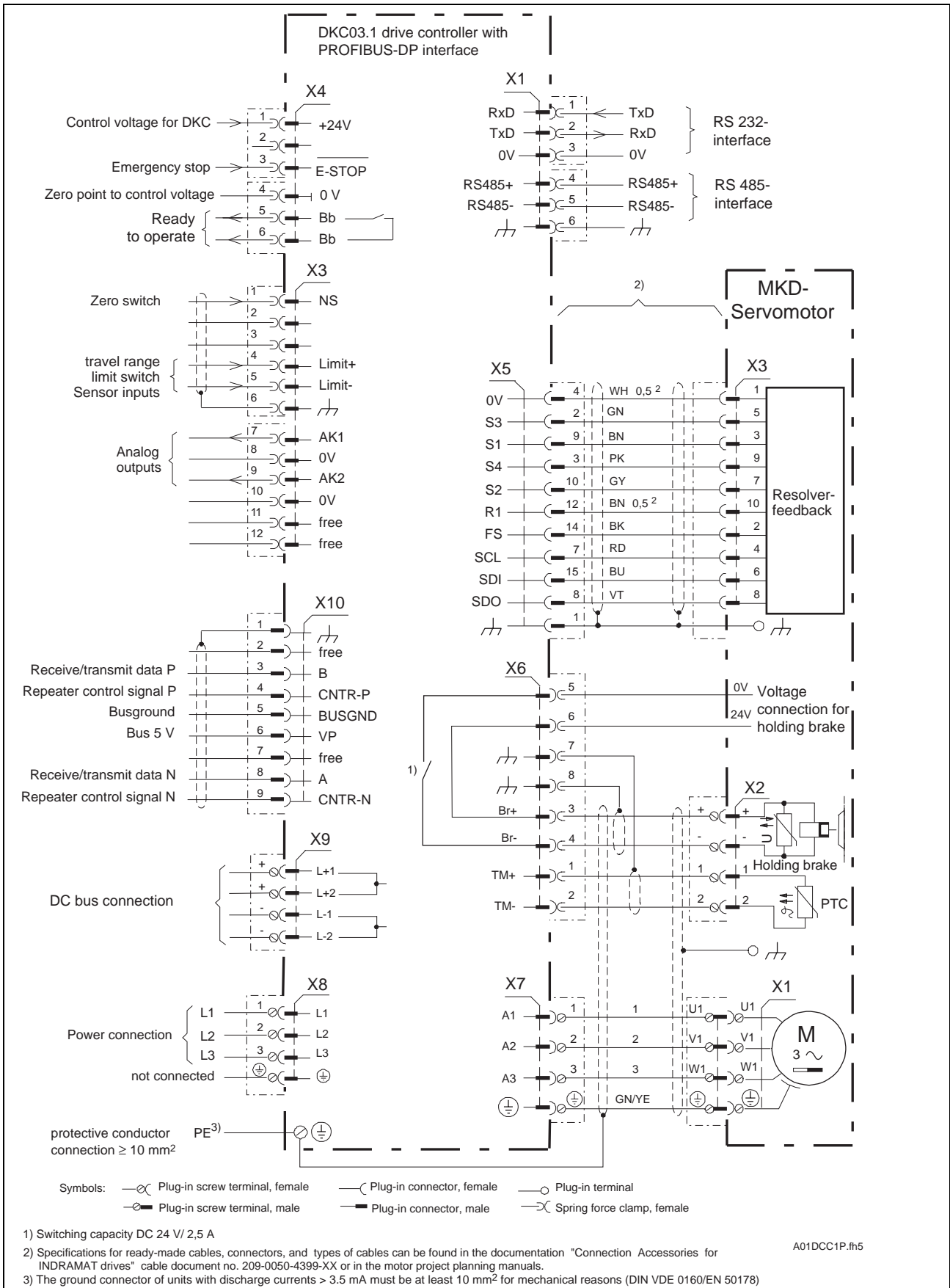

Fig. 4-13: Overall connection diagram DKC03.1 with PROFIBUS-DP

4.4 Electrical connection on the connection terminal strips

The electrical connections are described below:

- grouped according to the numbers of the connection terminal strip (for example, X1, X2 etc.) and
- according to the lower-level functions.

Serial interface X1

The serial interface is generally used for programming, parameterization and diagnostics during startup operation and service.

It can be alternatively operated as a RS-232 or RS-485.

RS-232 interface

The RS-232 interface is needed for programming, parameterizing and diagnosis during startup operation and service.

It is also used when setting the drive addresses as a prerequisite for operation via RS-485.

With the RS-232, it is possible to parameterize only one drive at a time when using the DriveTop startup program.

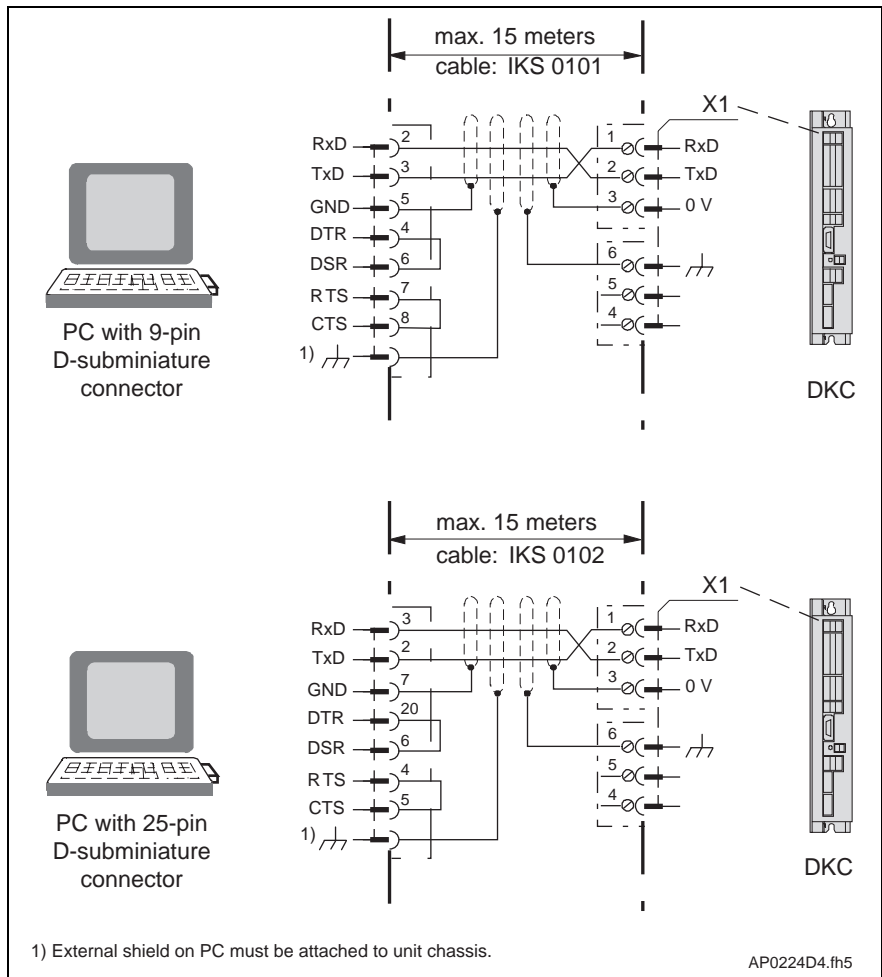

Fig. 4-14: Connecting a PC to an RS-232 interface on a DKC

RS-485 interface The RS-485 interface is needed for programming, parameterizing and diagnosis during startup operation and service.

The RS-485 interface allows :

- the implementation of a serial bus with up to 31 stations, connected by means of a two-wire cable (half duplex mode),
- a transmission length of up to 500 meters
- data rates of 9600/19200 baud and
- the implementation of a central PC-based visualisation unit.

Several DKCs can be put into operation with DriveTop without re-connecting the interface cable via the RS-485.

To operate DriveTop with several ECODRIVES, a RS-232/485 converter is required between the PC and the drives.

The following application example displays a tested assembly with RS-485 connection using the Phoenix Contact converter PSM-EG-RS-232/RS-485-P/2D.

Interface converter PSM-EG-RS-232/RS-485-P/2D

The Phoenix Contact interface converter PSM-EG-RS-232/RS-485-P/2D implements the interface in a way suited for industrial use and for assembly in control cabinets.

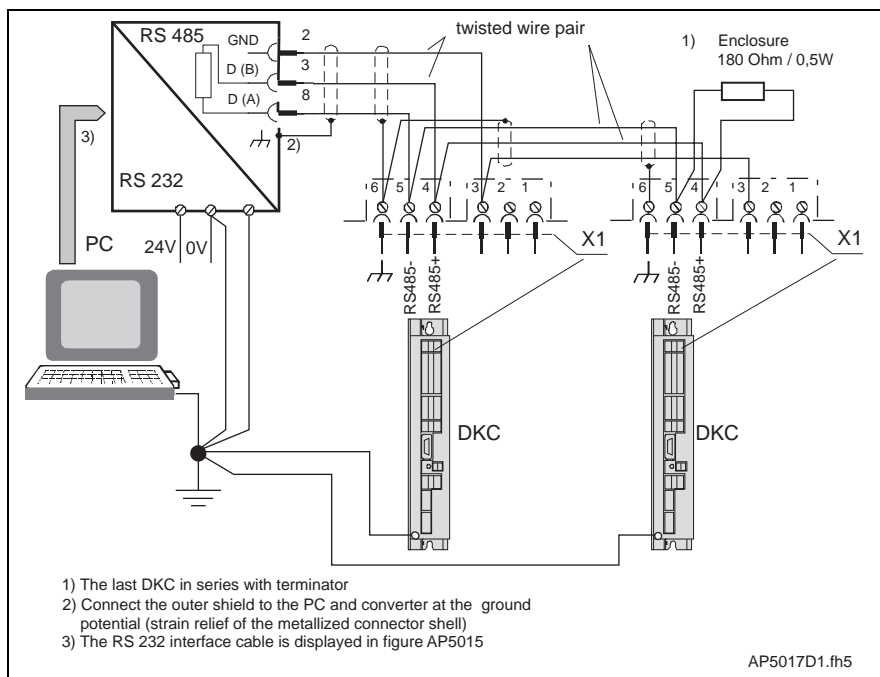

Fig. 4-15: RS-485 Connection of several DKCs

Note: The cable connection to the equipment must not be arranged in a star-shaped configuration but instead individually from one DKC to the next.

The RS-485 requires a terminator on both ends. Both the terminator integrated into the interface converter (180 Ohms) and the Pull-up and pull-down resistors (470 Ohms each) must be activated. The other end of the cable must also be terminated with a 180 Ohm / 0.5W resistor. The terminator is connected directly to the DKC, plug X1, pins 4 and 5.

Switch position in the interface converter

The converter can be modified for various peripherals using specific switch positions.

The switch positions shown here must be used for the following wiring diagrams.

- Switch RS-485 to **ON**
 ⇒ 180 Ohm circuit termination and 470 Ohms pull-up/down are connected
- Switch RS-232 to **DTE** (Data Terminal Equipment)
 data direction change-over for RS-485 via RTS
 ⇒ pin 2: TxD, pin 3: RxD,
- Set the jumper connection to 3 and 4
 data direction change-over polarity
 ⇒ transmit mode: signal to RTS +3V to +15V
 ⇒ receive mode: signal to RTS -3V to -15V

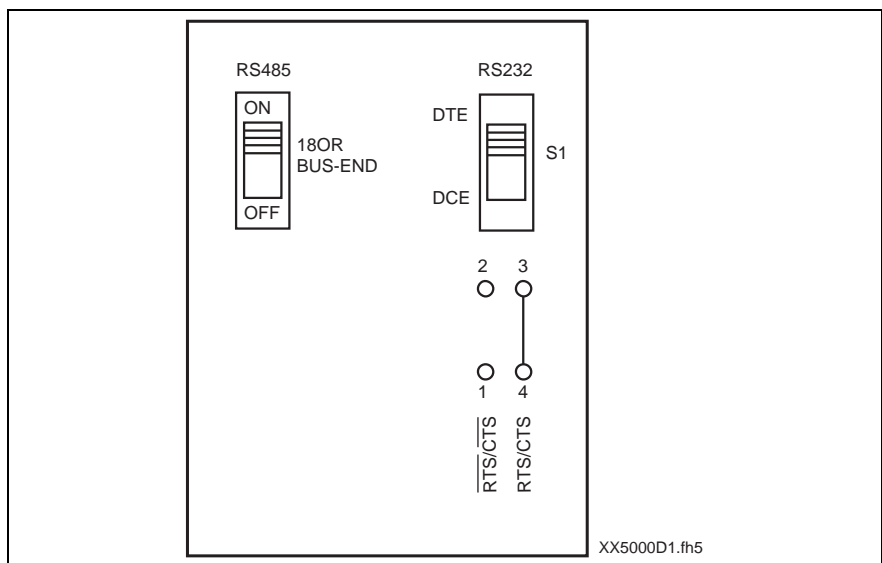

Fig. 4-16: Switch position /jumper position in the interface converter PSM-EG-RS-232 / RS-485-P / 2D

Connecting the RS-232 of the PCs to the interface converter

The interface converter must be connected via the D-SUB male connector because of the effects of interference.

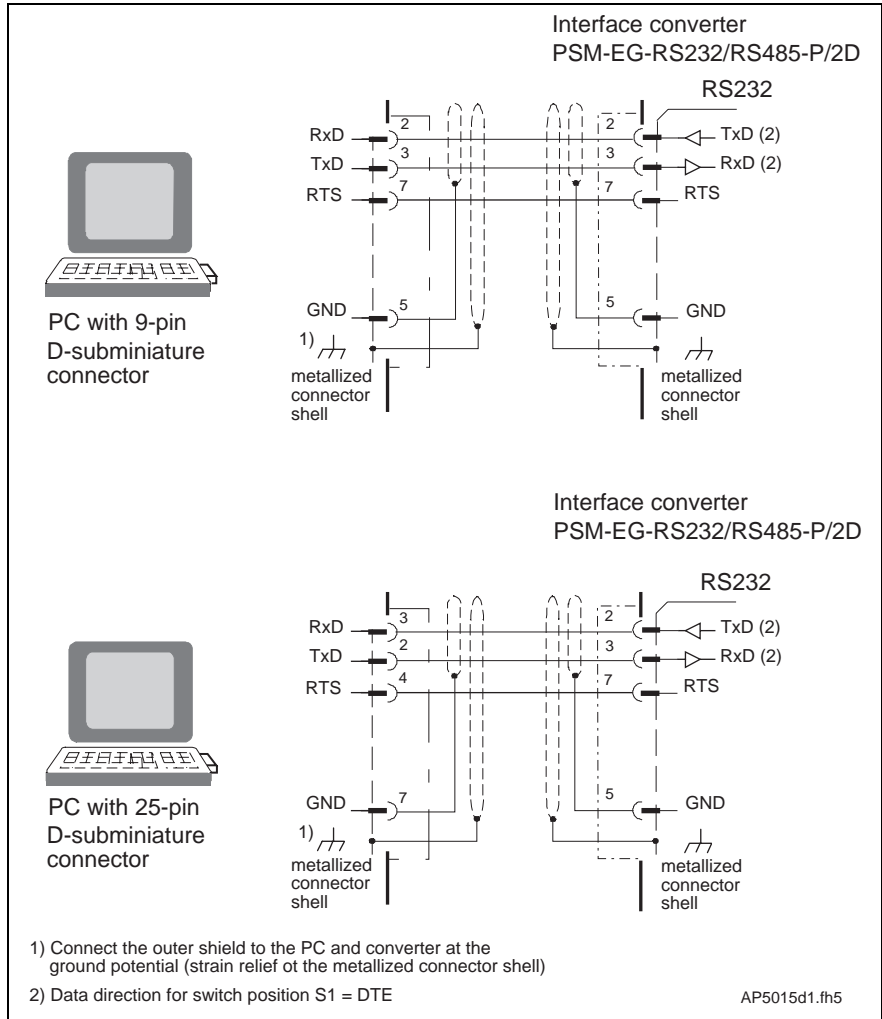

Fig. 4-17: RS-232 cable (PC interface converter)

Connecting the RS-485 of the interface converter to the DKC

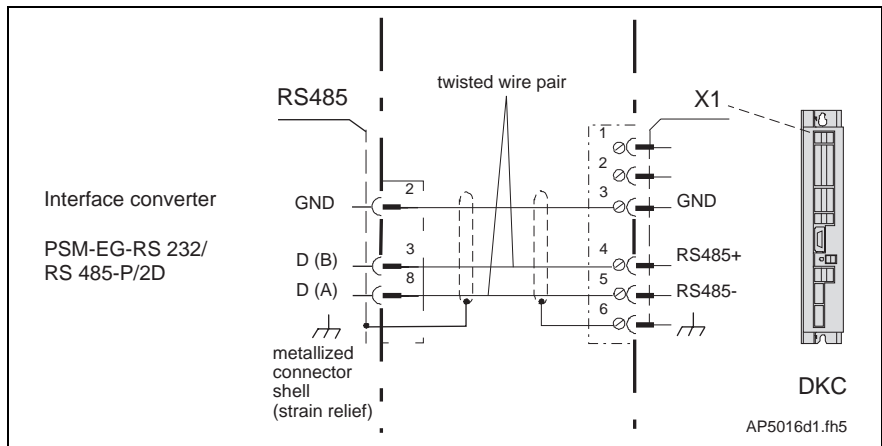

Fig. 4-18: RS-485 cable (interface converter - DKC)

X3 Control inputs and analog outputs

Control inputs for referencing

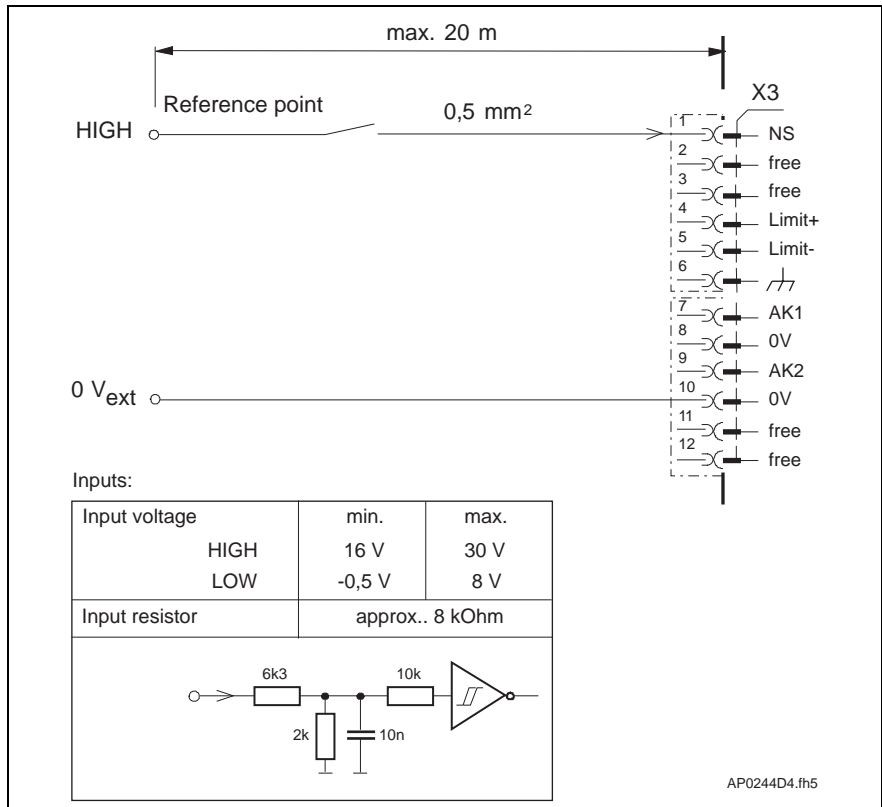

Fig. 4-19: Inputs for referencing

Travel range limit switches
Sensor inputs

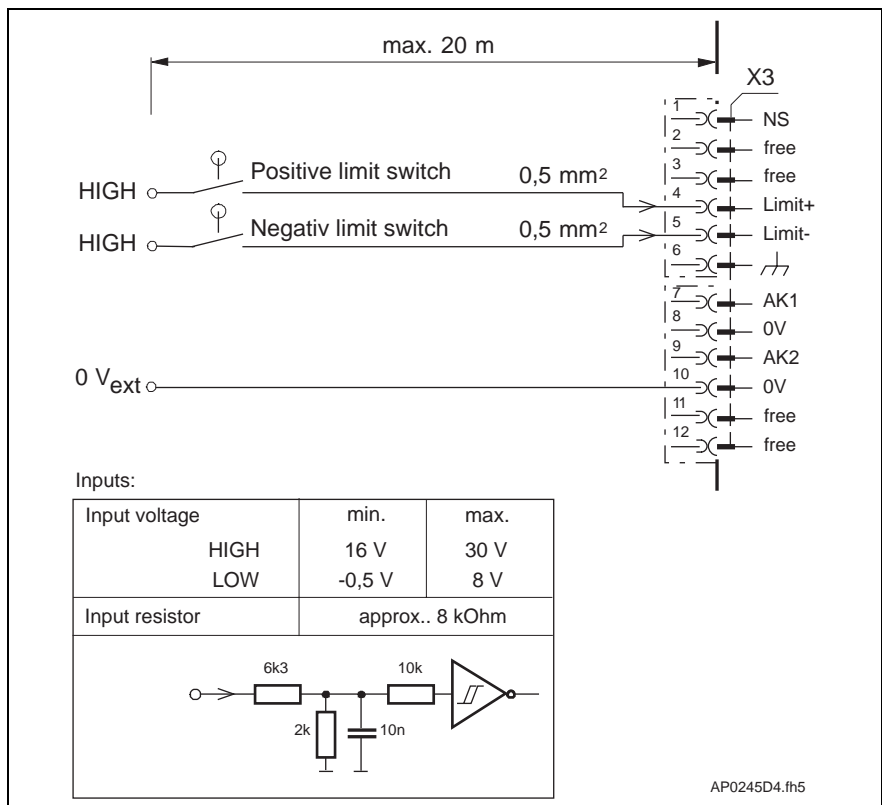

Fig. 4-20: Travel range limit switches / Sensor inputs

Diagnostic Outputs

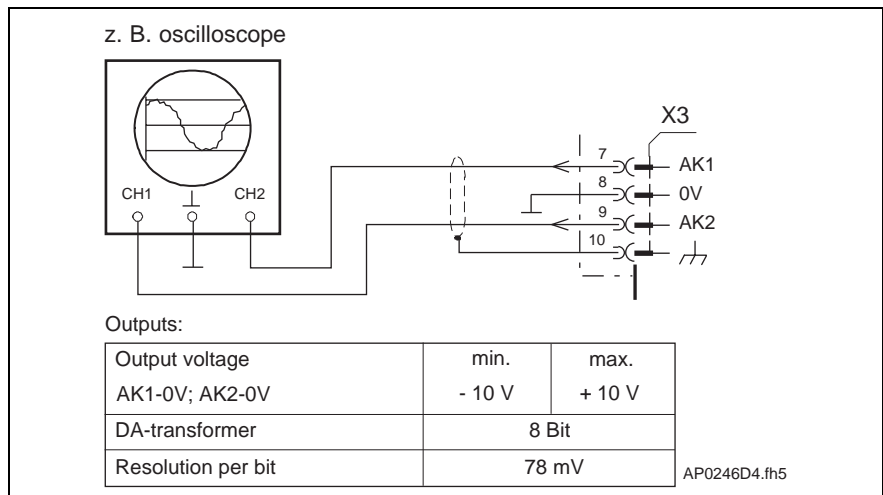

Fig. 4-21: Connection assignments for the diagnostic outputs

X4 Connections for the control circuit

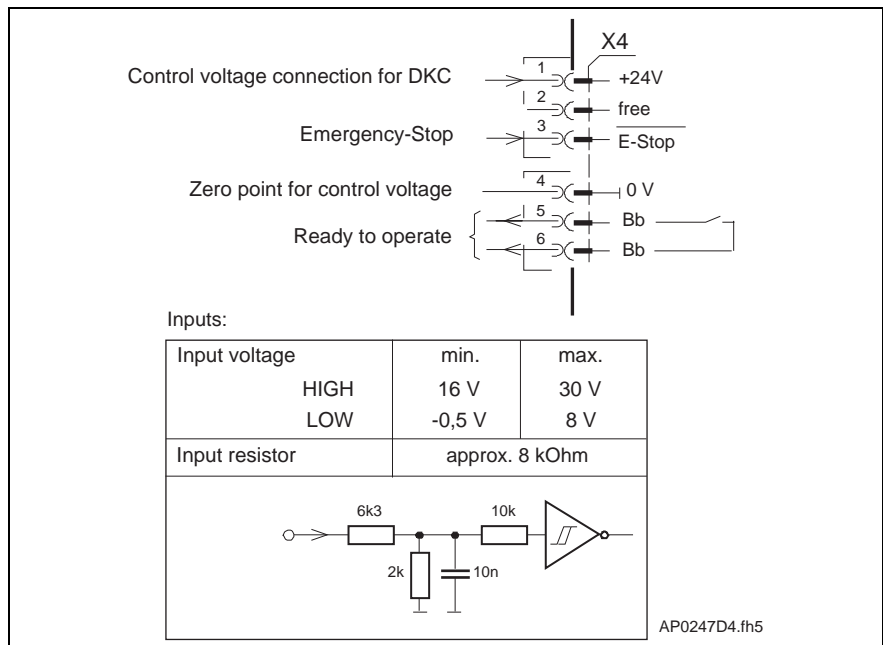

Fig. 4-22: Connections for the control inputs, control voltage, ready contacts, and emergency stop

X5, X6, X7 Motor connections

See the overall connection diagram in Fig. 4-13 for terminal connection assignment to the motor connections.

For further information, please see the documentation "ECODRIVE servomotors MKD" - Project Planning Manual -.

X9 DC Bus

DC bus connection to:
 an auxiliary bleeder module BZM01.1

- or -

an additional capacitance module CZM01.1

- or -

other DKC drives

See the overall connection diagram Fig. 4-13 for the connection assignment.

X10 PROFIBUS-DP Connection

The PROFIBUS cable is connected to this connector. The connector is not included in the delivery contents of the DKC03.1. It can be ordered separately. Drive control words are transmitted from the control to the drive via the PROFIBUS-DP. Drive status words are transmitted from the drive to the control.

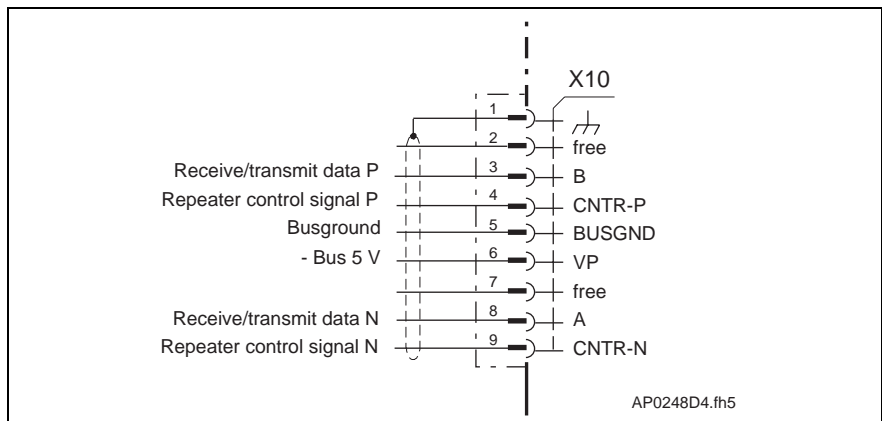

Fig. 4-23: PROFIBUS-DP connection

Bus Connector

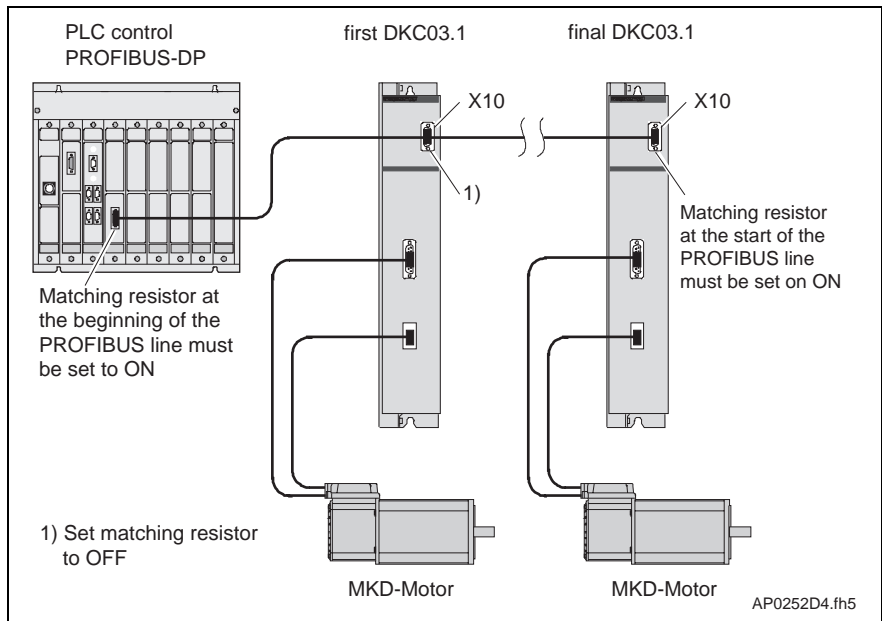

Fig. 4-24: An example of connecting a DKC03.1 to the PLC control via the PROFIBUS-DP

The PROFIBUS connectors each have a connectable terminator. The terminator must always be active at both the first and last bus stations. Do not interchange the A and B wires. Perform the connection as shown in the figures below.

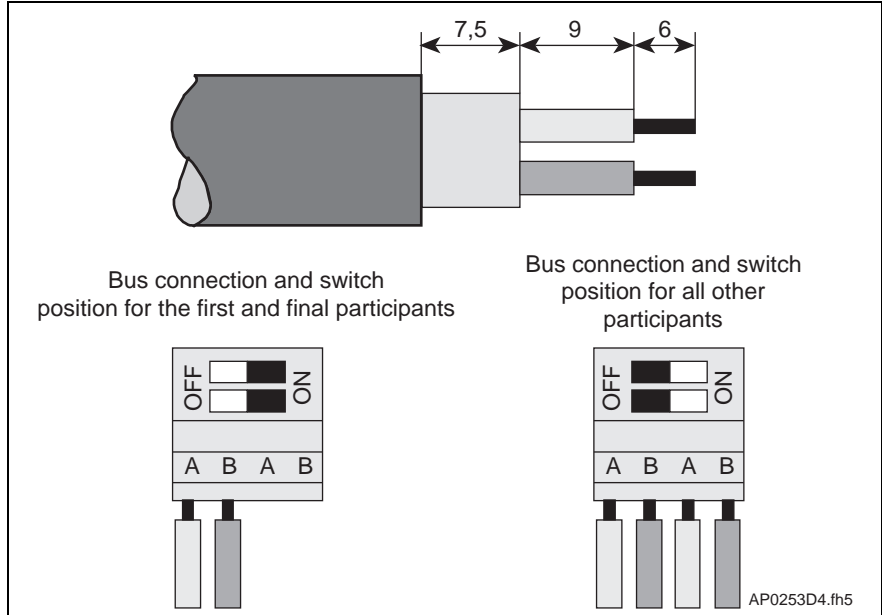

Fig. 4-25: Preparing the cable of a bus connector.

To prepare the cable, proceed as follows:

- Strip the cable (Fig. 4-25).
- Put the green and red wires into the terminal screw block.
- Press the cable sheath between both terminal connectors.
- Screw the green and red wires firmly in the terminals screws.

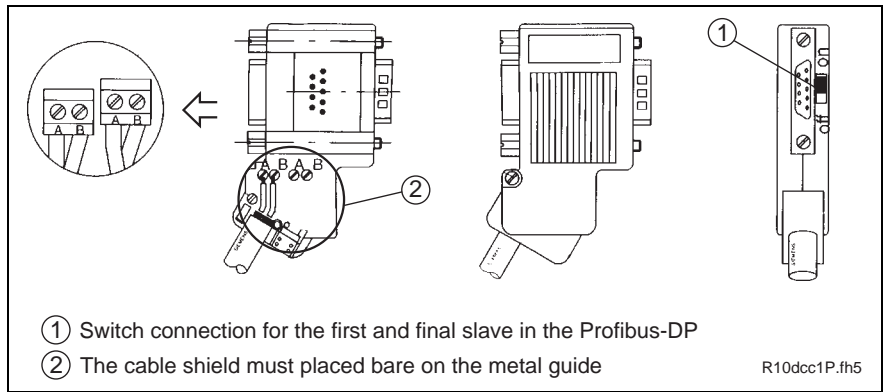

Fig. 4-26: Bus connection for the first and last slave, bus connector **with** 9-pin D-SUB socket, INS 0541

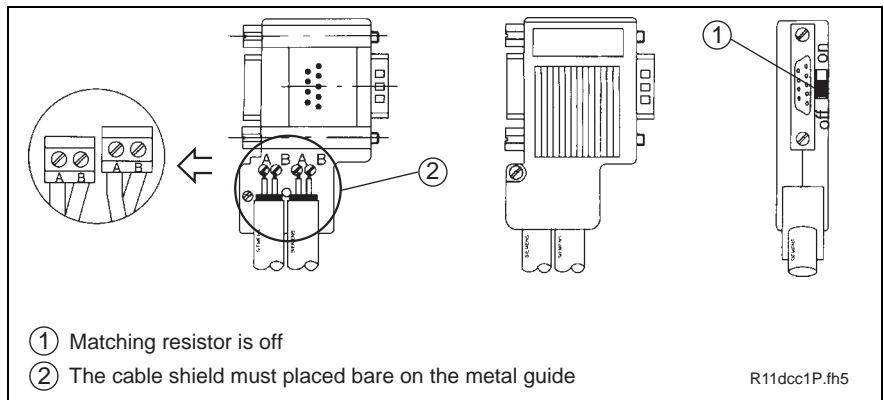

Fig. 4-27: Bus connection for all other slaves, bus connector **with** 9-pin D-SUB socket, INS 0541

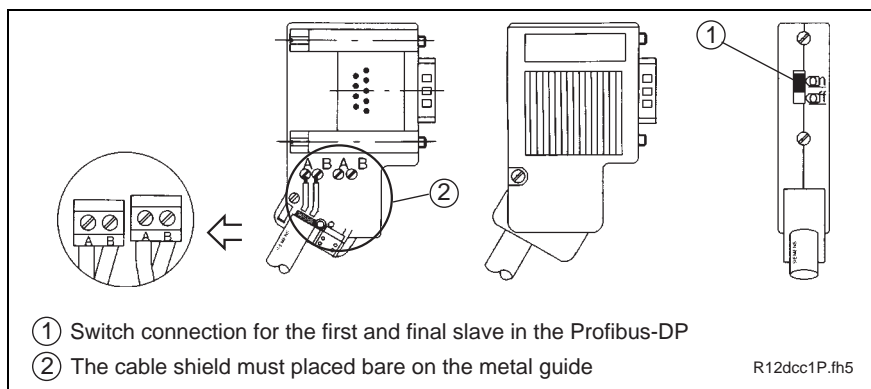

Fig. 4-28: Bus connection for the first and last slave **without** 9-pin D-sub socket, INS 0540

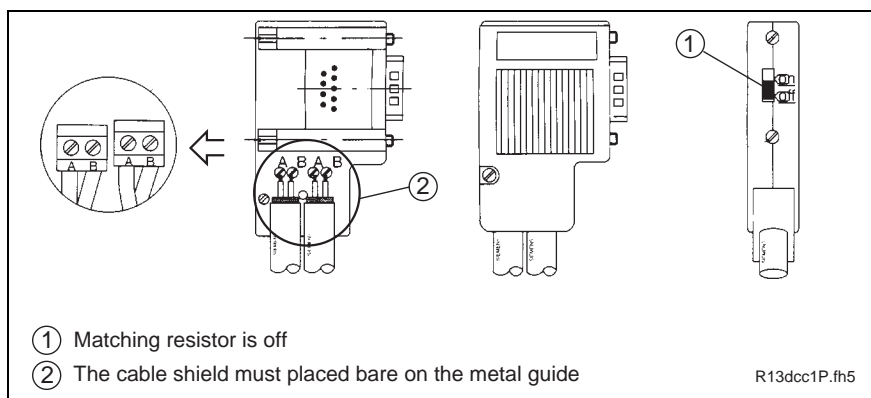

Fig. 4-29: Bus connection for all other slaves **without** 9-pin D-sub socket, INS 0540

Connect the DKC03.1 to a control unit using a shielded two-wire cable in accordance with DIN 19245/section 1.

5 BZM Auxiliary Bleeder Module

5.1 Dimensioning the components for regeneration

For each servo application, it is necessary to check whether the

- continuous regenerative power
- peak regenerative power
- regenerative energy

needed for the application can be sufficiently absorbed by the bleeder (brake resistance).

If the available regenerative power and energy from the mechanics exceeds the absorbing capabilities of the bleeder built into the unit, then this capability can be increased on the DKC**.*-040-7-FW with the use of the following hardware configurations.

- A drive controller and auxiliary bleeder module connected via the DC bus circuit. (1 DKC+BZM)
- Several drive controllers connected via the DC bus circuit. (up to 6 DKCs)
- Several drive controllers and auxiliary bleeder modules connected via the DC bus circuit. (up to 6 DKC+BZM)

1 DKC + BZM

1. Continuous regenerated power

$$P_{RD} \leq P_{BD, DKC} + P_{BD, BZM}$$

$$P_{RD} = \frac{\sum W_{ROT} + \sum W_{POT}}{t_z \cdot 1000}$$

$$W_{ROT} = \frac{(J_{LAST} + J_M)}{2} \cdot \left(n_{NUTZ} \cdot \frac{2 \cdot \pi}{60} \right)^2 \cdot z_{DEC}$$

$$W_{POT} = m_{LAST} \cdot g \cdot h \cdot z_{AB}$$

2. Peak regenerative power

$$P_{RS} \leq P_{BM, DKC} + P_{BM, BZM}$$

P_{RS} - > see selection data of the servo drives

3. Regenerative energy (a single braking in emergency stop)

$$W_{POT, MAX} + W_{ROT, MAX} \leq W_{MAX, DKC} + W_{MAX, BZM}$$

$W_{MAX, DKC}$ - > see Fig. Technical specifications DKC

$W_{MAX, BZM}$ - > see Fig. Technical specifications BZM

P_{RD} :	Continuous regenerative power from the mechanical system during operation in kW
$P_{BD, DKC}$:	Continuous regenerative power that the drive controller can process in continuous operation in kW
$P_{BD, BZM}$:	Continuous regenerative power that the auxiliary module can process in continuous operation, in kW
P_{RS} :	Peak regenerative power in kW
W_{ROT} :	Rotary energy in Ws
W_{POT} :	Potential energy in Ws
$W_{ROT, MAX}$:	Max. rotary energy released in an emergency stop in Ws
$W_{POT, MAX}$:	Max. potential energy released in an emergency stop in Ws
t_z :	Cycle time in sec.
J_{LAST} :	Load moment of inertia in kgm ²
J_M :	Motor moment of inertia, in kgm ²
m_{LAST} :	Load weight in kg
$W_{MAX, BZM}$:	Storable energy in BZM in kW
$W_{MAX, DKC}$:	Storable energy in DKC in kW
g :	Gravitational acceleration 9.81 ms ⁻²
h :	Lowering dimension in m
n_{NUTZ} :	Motor speed used in min ⁻¹
z_{AB} :	Number of drops per cycle
z_{DEC} :	Number of braking actions per cycle

Fig. 5-1: Check the conditions for regenerative power and regenerative energy in a DKC connected to a BZM via a DC bus

up to 6 DKCs

1. Continuous regenerated power

$$\sum P_{RD} \leq 0,8 \cdot \sum P_{BD,DKC}$$

$$P_{RD} = \frac{\sum W_{ROT} + \sum W_{POT}}{t_z \cdot 1000}$$

$$W_{ROT} = \frac{(J_{LAST} + J_M)}{2} \cdot (n_{NUTZ} \cdot \frac{2 \cdot \pi}{60})^2 \cdot z_{DEC}$$

$$W_{POT} = m_{LAST} \cdot g \cdot h \cdot z_{AB}$$

2. Peak regenerative power

$$\sum P_{RS} \leq 0,8 \cdot P_{BM,DKC}$$

P_{RS} -> see selection data of the servo drives

3. Regenerative energy (a single braking in emergency stop)

$$\sum W_{POT,MAX} + \sum W_{ROT,MAX} \leq 0,8 \cdot \sum W_{MAX,DKC}$$

$W_{MAX,DKC}$ -> see Fig. Technical specifications DKC

P_{RD} :	Continuous regenerative power from the mechanical system in continuous operation in kW
$P_{BD,DKC}$:	Continuous regenerative power that the drive controller can process in kW
P_{RS} :	Peak regenerative power in kW
W_{ROT} :	Rotary energy in Ws
W_{POT} :	Potential energy in Ws
$W_{ROT,MAX}$:	Max. rotary energy released in an emergency stop in Ws
$W_{POT,MAX}$:	Max. potential energy released in an emergency stop in Ws
t_z :	Cycle time in s
J_{LAST} :	Load moment of inertia in kgm ²
J_M :	Motor moment of inertia, in kgm ²
m_{LAST} :	Load weight in kg
$W_{MAX,BZM}$:	Storable energy in BZM 01.1 in kW
$W_{MAX,DKC}$:	Storable energy in DKC in kW
g :	9.81 ms ²
h :	Lowering dimension in m or number of braking actions
n_{NUTZ} :	Motor speed used in min ⁻¹
z_{AB} :	Number of drops per cycle
z_{DEC} :	Number of braking actions per cycle

Fig. 5-2: Check the conditions for regenerative power and regenerative energy with several DKCs connected via a DC bus

up to 6 DKCs + BZM

1. Continuous regenerated power

$$\sum P_{RD} \leq 0,8 \cdot \sum P_{BD,DKC} + \sum P_{BD,BZM}$$

$$P_{RD} = \frac{\sum W_{ROT} + \sum W_{POT}}{t_z \cdot 1000}$$

$$W_{ROT} = \frac{(J_{LAST} + J_M)}{2} \cdot (n_{NUTZ} \cdot \frac{2 \cdot \pi}{60})^2 \cdot z_{DEC}$$

$$W_{POT} = m_{LAST} \cdot g \cdot h \cdot z_{AB}$$

2. Peak regenerative power

$$\sum P_{RS} \leq 0,8 \cdot P_{BM,DKC} + P_{BM,BZM}$$

P_{RS} -> see selection data of the servo drives

3. Regenerative energy (a single braking in emergency stop)

$$\sum W_{POT,MAX} + \sum W_{ROT,MAX} \leq 0,8 \cdot \sum W_{MAX,DKC} + \sum W_{MAX,BZM}$$

$W_{MAX,DKC}$ -> see Fig. Technical specifications DKC

$W_{MAX,BZM}$ -> see Fig. Technical specifications BZM

P_{RD} :	Continuous regenerative power from the mechanical system in continuous operation in kW
$P_{BD,DKC}$:	Continuous regenerative power that the drive controller can process in continuous operation in kW
P_{RS} :	Peak regenerative power in kW
W_{ROT} :	Rotary energy in Ws
W_{POT} :	Potential energy in Ws
$W_{ROT,MAX}$:	Max. rotary energy released in an emergency stop in Ws
$W_{POT,MAX}$:	Max. potential energy released in an emergency stop in Ws
t_z :	Cycle time in sec.
J_{LAST} :	Load moment of inertia in kgm ²
J_M :	Motor moment of inertia, in kgm ²
m_{LAST} :	Load weight in kg
$W_{MAX,BZM}$:	Storable energy in BZM 01.1 in kW
$W_{MAX,DKC}$:	Storable energy in DKC in kW
g :	9.81 ms ²
h :	Lowering dimension in m or number of braking actions
n_{NUTZ} :	Motor speed used in min ⁻¹
z_{AB} :	Number of drops per cycle
z_{DEC} :	Number of braking actions per cycle

Fig. 5-3: Check the conditions for regenerative power and regenerative energy in a DKC connected to a BZM via a DC bus

5.2 Dimensional sheet and installation dimensions

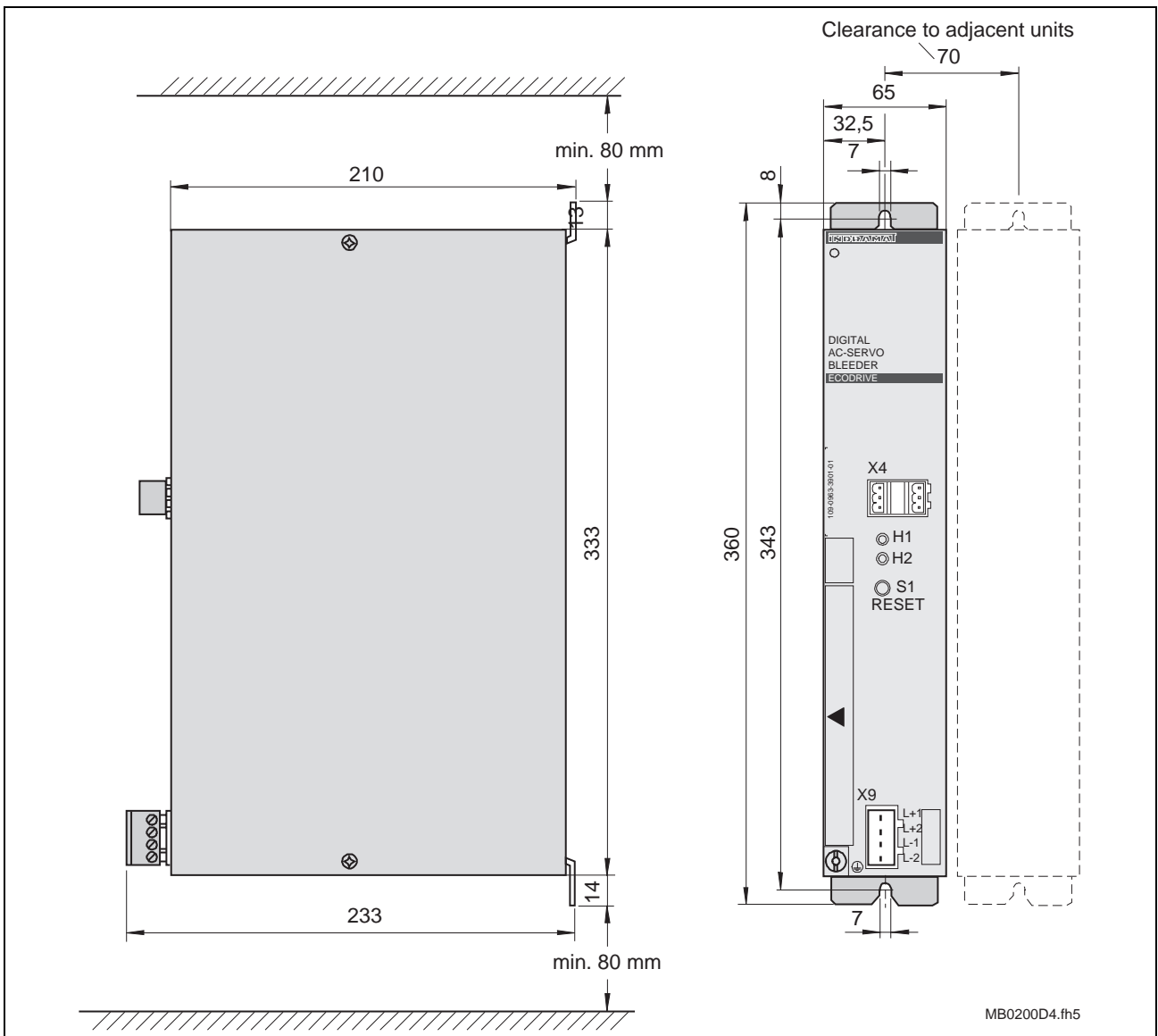

Fig. 5-4: Dimensions for the auxiliary bleeding module BZM01.1

The BZM is delivered with attached terminal screws. Spring-tension terminals are additionally enclosed for the X4 connection.

5.3 Technical specifications

Designation	Symbol	Unit	Value
Continuous bleeder output	$P_{BD,BZM}$	kW	1
Peak bleeder output	$P_{BM,BZM}$	kW	40 (perm. load cycle on for 1s, off for 40s)
Maximum feedback energy	$W_{MAX,BZM}$	kWs	40
Control voltage	$U_{N,BZM}$	V	DC 24 V \pm 20%
Current consumption of the 24 V connection	$I_{N,BZM}$	mA	90

TB0209D4.fh5

Fig. 5-5: Technical specifications BZM

5.4 Front view

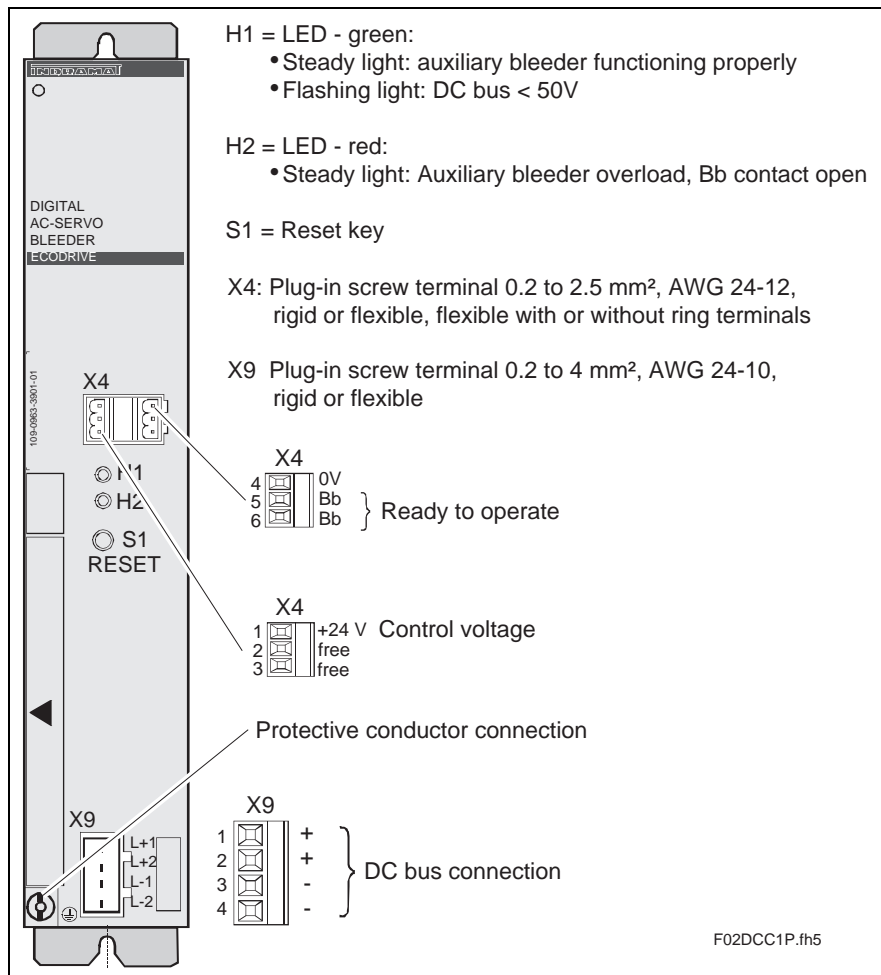

Fig. 5-6: Front view auxiliary bleeder module BZM01.1 with connection terminals

5.5 Electrical connection

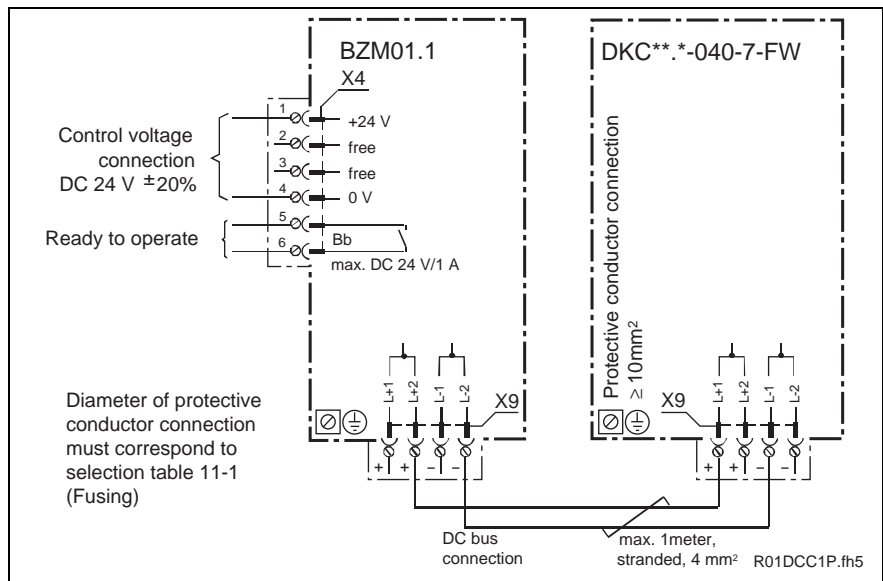

Fig. 5-7: Connection assignment auxiliary bleeding module BZM01.1

5.6 Type code and rating plate

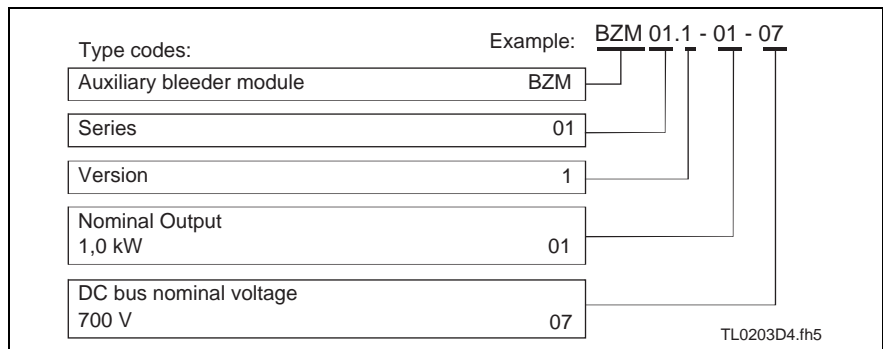

Fig. 5-8: Type code

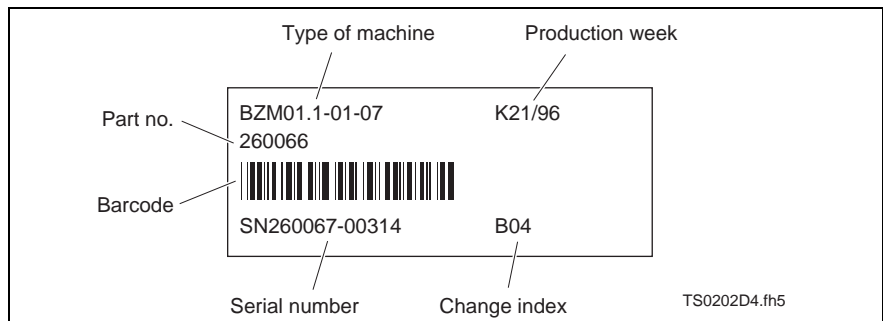

Fig. 5-9: Rating plate

Notes

6 CZM Auxiliary Capacitance Module

6.1 Dimensioning

When the drive is braked, the rotational energy available in the mechanics is released as regenerative energy in the DC bus of the DKC. It can be

- released in the form of heat loss in the bleeder module or auxiliary bleeder built into the DKC

- or -

- stored as energy in the DKC with a connected auxiliary capacitance module and re-used for subsequent acceleration procedures. This reduces the power dissipated in the control cabinet and lowers, and its own energy consumption is reduced.

To successfully implement it while avoiding unnecessary power loss in the control cabinet, note the following:

$$W_{ROT} \leq W_{ZW, DKC+CZM}$$

Fig. 6-1: Avoiding power loss from regenerative energy

Calculating the rotary energy of an application

$$W_{ROT} = \frac{(J_{LAST} + J_M)}{2} \cdot (n_{NUTZ} \cdot \frac{2 \cdot \pi}{60})^2$$

W_{ROT} : Rotary energy of the application in Ws
 n_{NUTZ} : Maximum usable speed in min^{-1}
 J_{LAST} : Load moment of inertia of the application in kgm^2
 J_M : Motor moment of inertia

Fig. 6-2: Calculating the rotary energy

Storable energy in a DKC with a connected CZM01.1

$$W_{ZW, DKC+CZM} = \frac{(C_{DKC} + C_{CZM})}{2} \cdot (U_B^2 - U_{ZW}^2) \cdot 10^{-3}$$

$W_{ZW, DKC+CZM}$: Storable energy in DKC with CZM in Ws
 C_{CZM} : Capacity of the CZM in mF (value = 1.0 mF)
 C_{DKC} : DC bus capacitance of the DKC in mF (value = 0.15 mF)
 U_B : U_B : Response threshold of the bleeder in DKC in V (value = 820)
 U_{ZW} : Nominal voltage (DC bus) in V ($U_{ZW} = \sqrt{2} \cdot 0.98 U_N$)
 U_N : Mains voltage (effective value) in V

Fig. 6-3: Calculating the storable energy with a CZM01.1

Application Example DKC01.-40-7 with Servomotor MKD 071 B with the following data:

Designation	Value
Rotor moment of inertia of the MKD 071 B	$J_M = 0.00087 \text{ kgm}^2$
Maximum usable motor speed	$n_{\text{Nutz}} = 3200 \text{ min}^{-1}$
Load inertia of the application	$J_{\text{LAST}} = 0.00261 \text{ kgm}^2$
Cycle time	$t_Z = 0.8 \text{ s}$
Mains voltage	$U_N = 400 \text{ V}$

Fig. 6-4: Technical specifications for application example with DKC01.1 with MKD

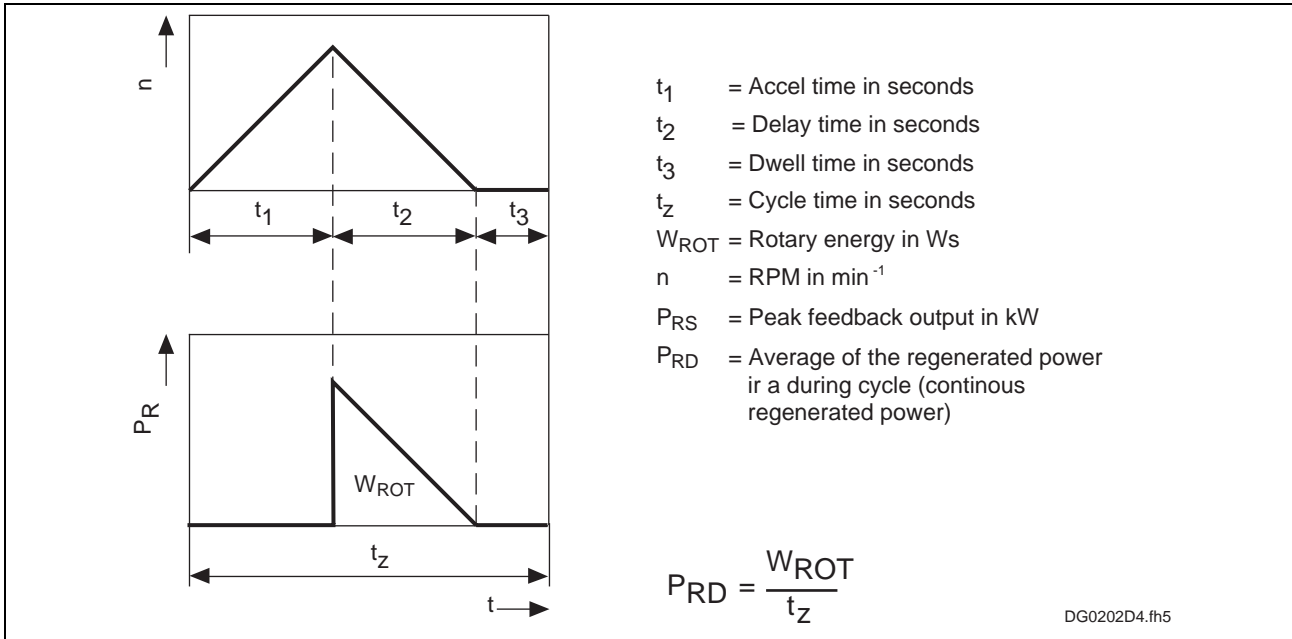

Fig. 6-5: Calculating the regenerative power in the processing cycle

This produces the following results:

$$W_{\text{ROT}} = 195 \text{ Ws}$$

$$W_{\text{ZW, DKC+CZM}} = 209 \text{ Ws}$$

This means that the condition $W_{\text{ROT}} \leq W_{\text{ZW, DKC+CZM}}$ has been fulfilled. If the same amount of energy were released via a bleeder, then, due to the cycle time, a continuous regenerative power of 243 Watts would result. This would remain within the control cabinet in the form of dissipated power.

6.2 Dimensional sheet and installation dimensions

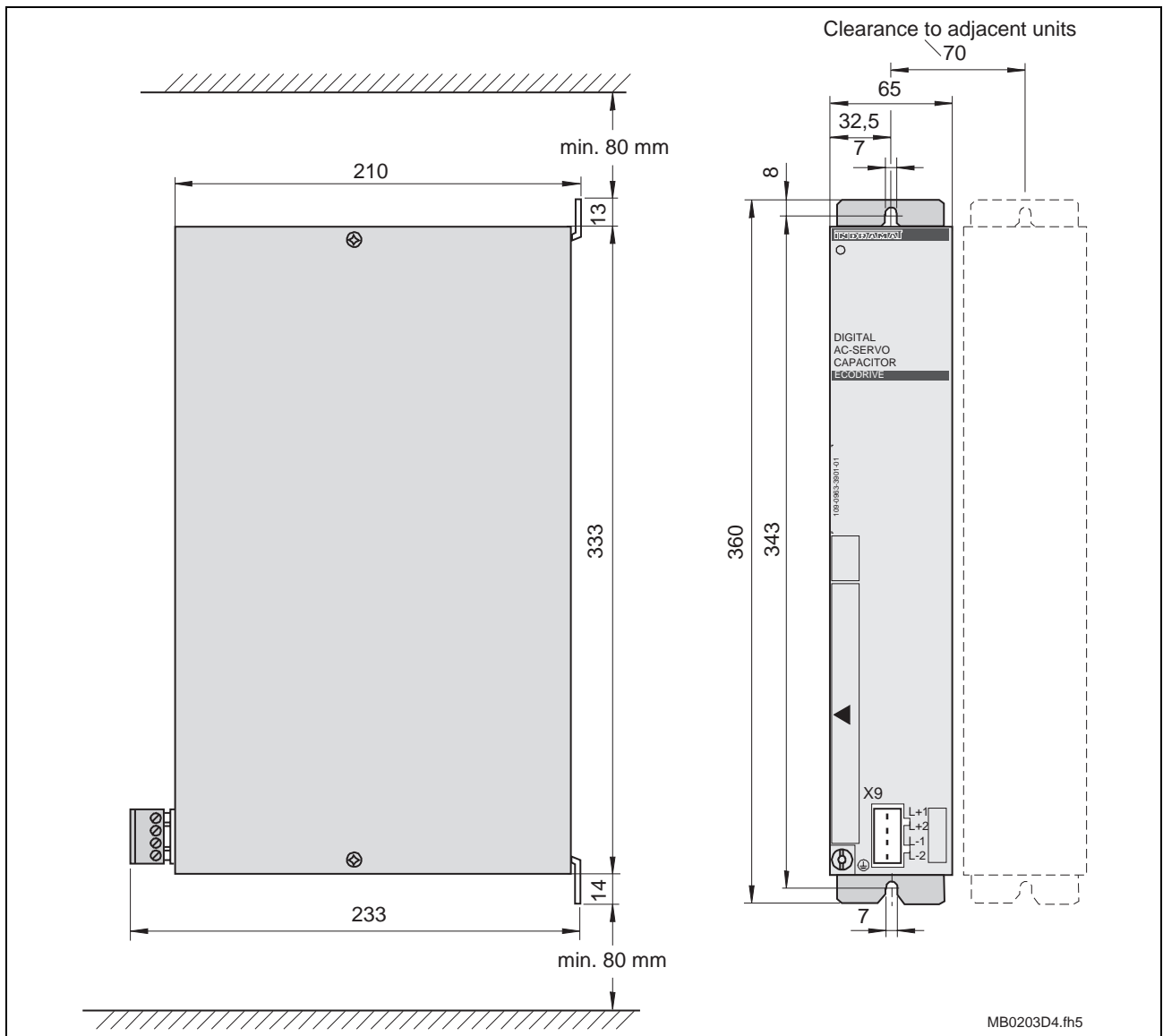

Fig. 6-6: Dimensions for the auxiliary capacitance modules CZM01.1

6.3 Front view

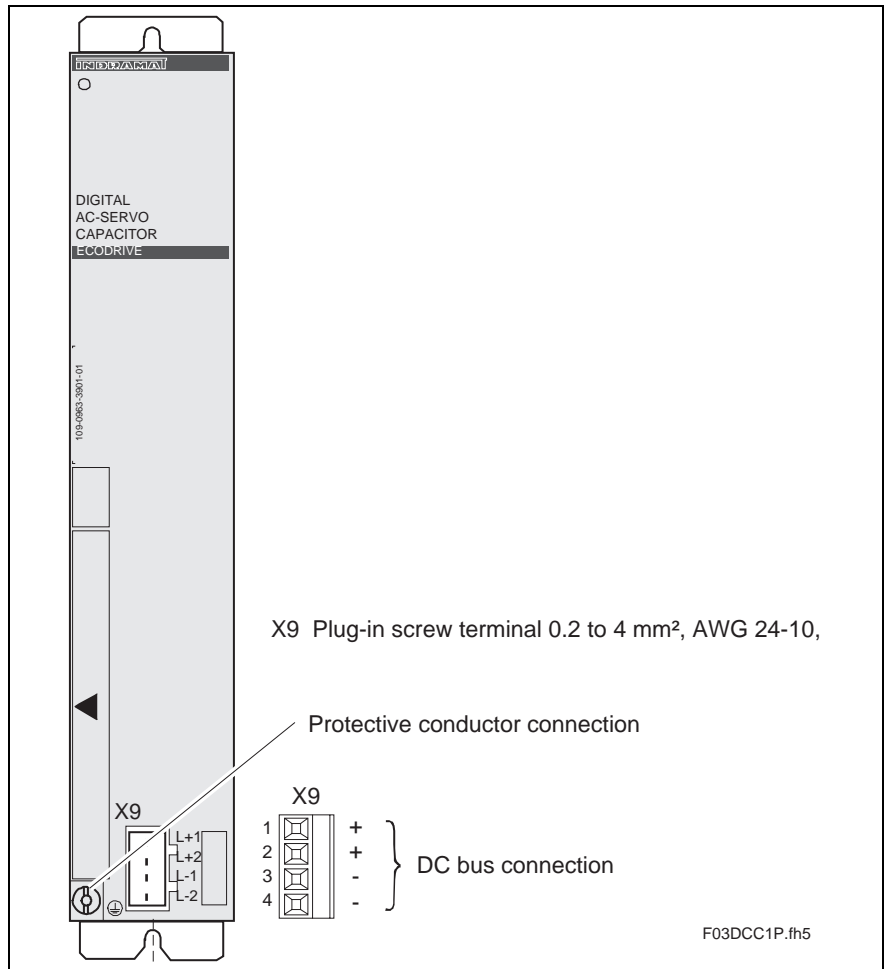

Fig. 6-7: Dimensions for the auxiliary capacitance modules CZM01.1

6.4 Electrical connection

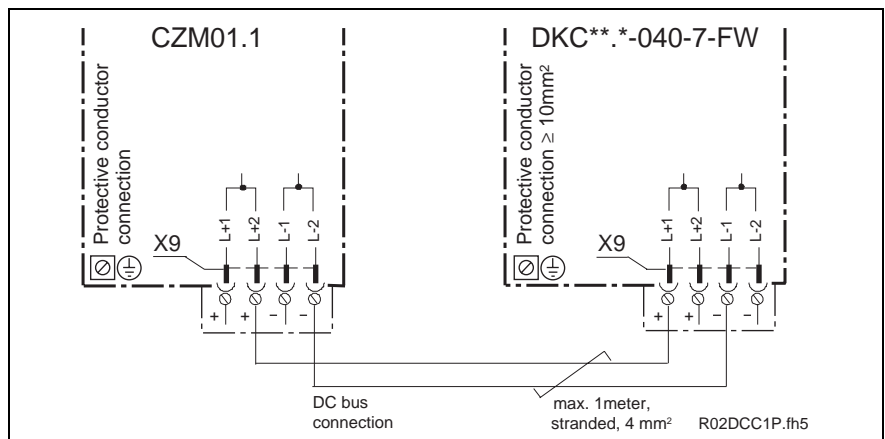

Fig. 6-8: Dimensions for the auxiliary capacitance modules CZM01.1

6.5 Type codes and rating plate

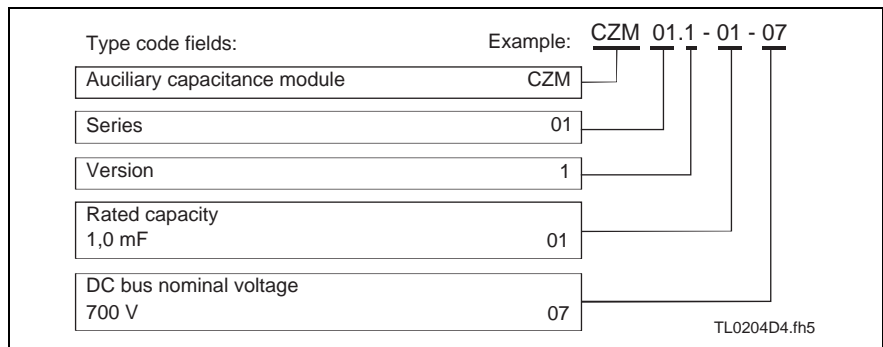

Fig. 6-9: Type code

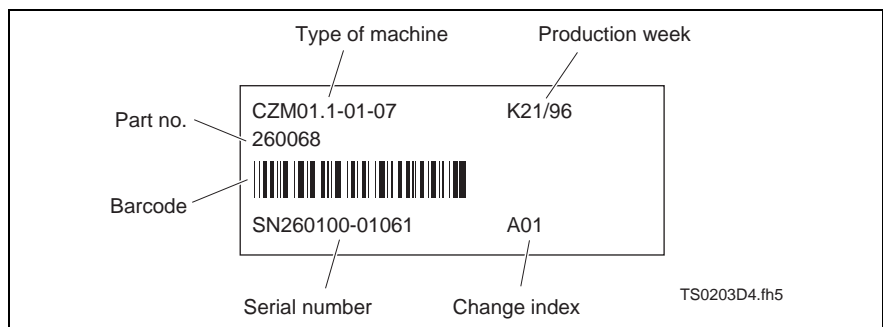

Fig. 6-10: Rating plate

Notes

7 DC24V NTM Power Supplies

7.1 Application recommendation

If there is no external DC24V control voltage available, then INDRAMAT recommends the use of NTM power supplies.

- Features**
- The power supplies contain an overvoltage safety switch with automatic shutdown. After the automatic shutdown device responds, operation can be restarted by switching the power supply off and on again briefly.
 - The power supplies always function with a starting current limiter. However, if you switch the power supplies off and on again within a period of ten seconds, the starting current limiter may not work!
 - The power supplies NTM01.1-024-004 and NTM01.1-024-006 make it possible to measure the voltage applied to the load via sensor cables. If there is a voltage drop, the power supply will increase the output voltage accordingly.

Fuse protection Q2 INDRAMAT recommends a 10A automatic circuit breaker of 10 A with tripping characteristics for DC24V NTM power supplies.

Interference suppression Use mains filter NFE01.1-250-006 for interference suppression.

7.2 Technical specifications

Designation	Symbol	Unit	NTM01.1-024-002	NTM01.1-024-004	NTM01.1-024-006
Nominal current of the 24 V output for the 45°C ambient temperature	I_N	A	2.1	3.8	5.5
Output for 45°C ambient temperature	P_{OUT}	W	50	100	150
Input current at 230 (115) V	I_{IN}	A	0.61 (1.2)	1.2 (2.2)	1.9 (3.2)
Inrush current at 230 (115) V in the mains supply lead when powering up. Make sure fuse has proper size.	I_{EIN}	A	32 (16)	32 (16)	32 (16)
Input voltage	U_N	V	Standard AC 170 to 265 by rearranging a bridge AC 85...132		
RF interference suppression filter			NFE01.1-250-006 (recommended interference suppression filter to maintain EMC values)		

TB0201D4.th5

Fig. 7-1: Technical specifications for DC24V NTM power supplies

7.3 Dimensional sheets and installation dimensions

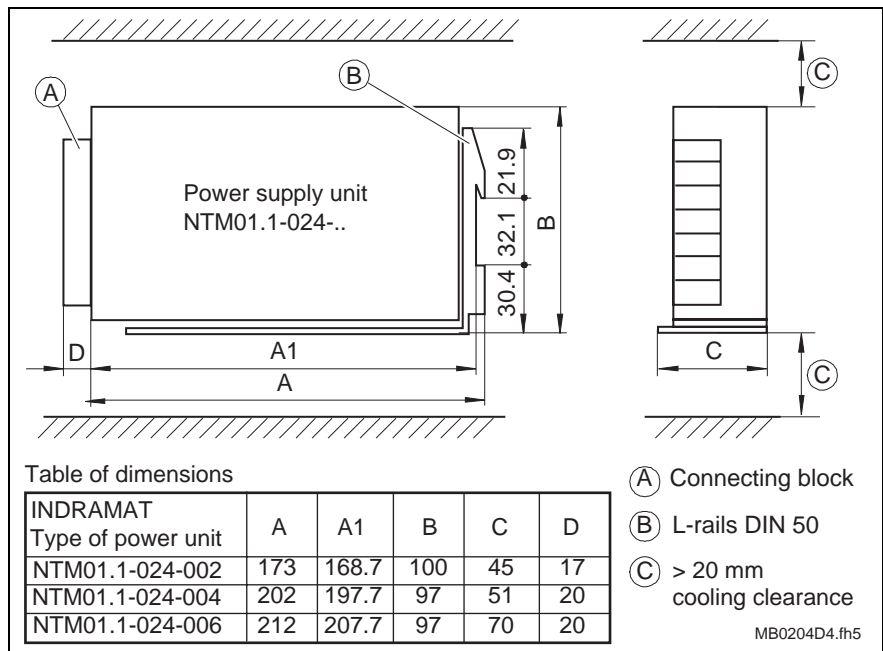

Fig. 7-2: Dimensional sheet DC24V NTM power supplies

7.4 Front view

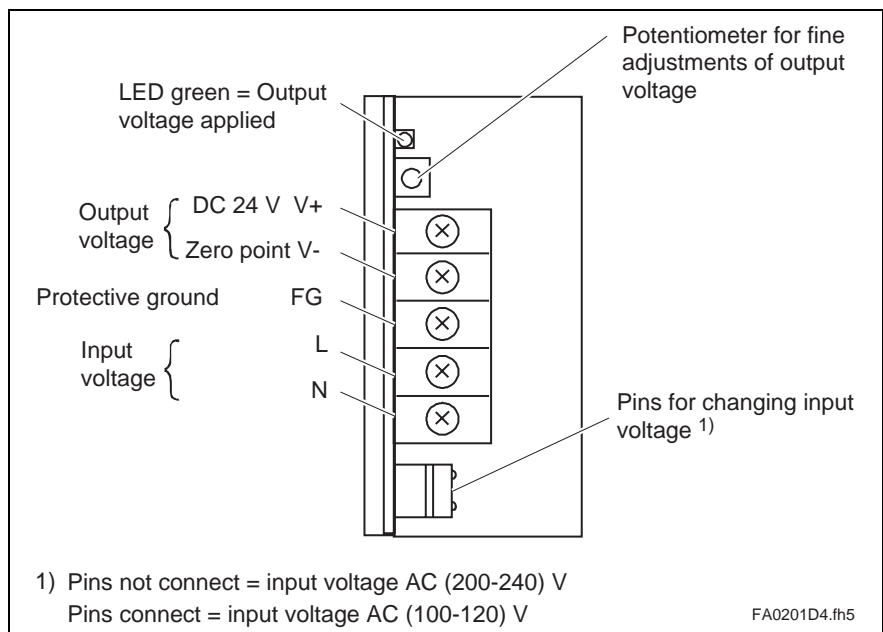

Fig. 7-3: Front view and terminal designations of the power supply NTM01.1-024-002

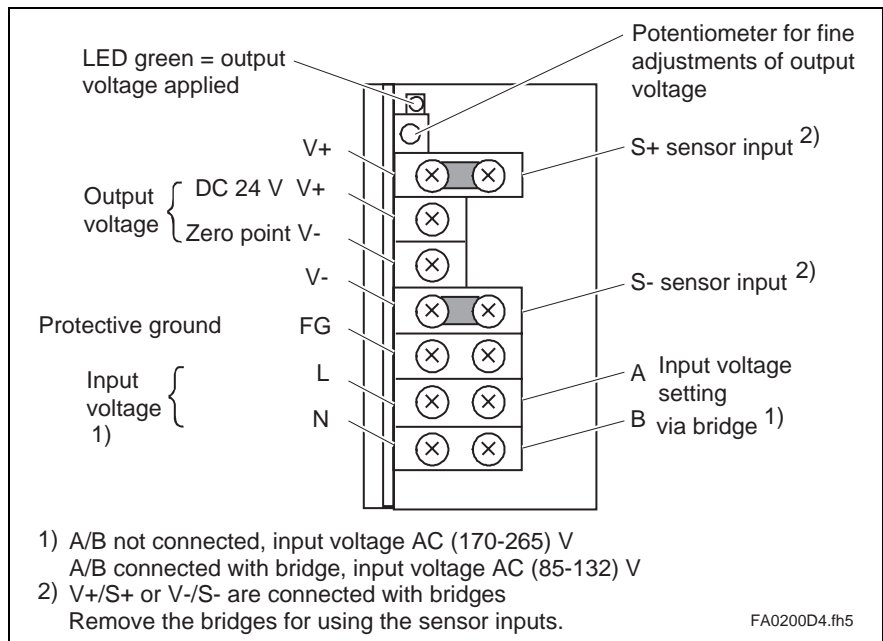

Fig. 7-4: Front view and terminal designations for the power supplies NTM01.1-024-004 and NTM01.1-024-006

7.5 Electrical connection

Note: Always connect the 0V connection on the secondary side of the CD24V power supplies to the central earth point in the control cabinet. (See also 8.3 Electrical connection)

Always use the NTM together with the NFE01.1-230-006 mains filter.

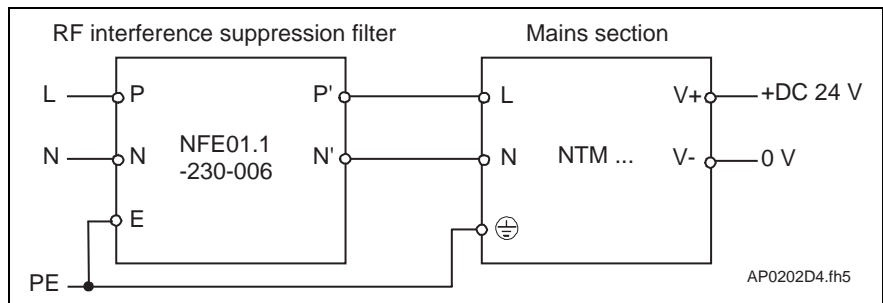

Fig. 7-5: Connecting the power supply to a mains filter

Note: The bridge circuits V+/S+ and V-/S- must be removed if sensor inputs are used.

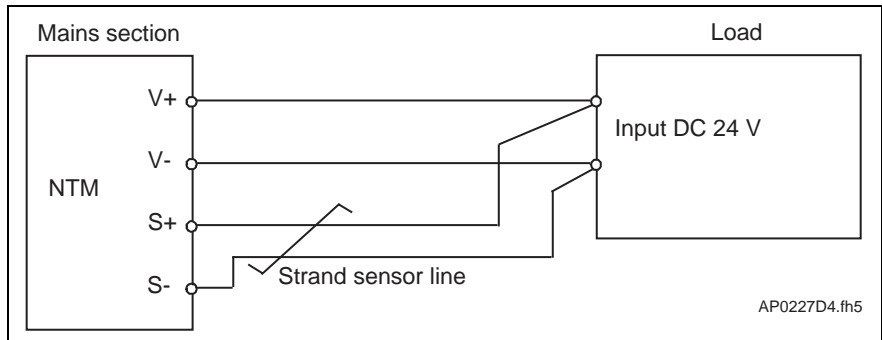

Fig. 7-6: Connecting the sensor leads NTM01.1-024-004 and NTM01.1-024-006

7.6 Type code

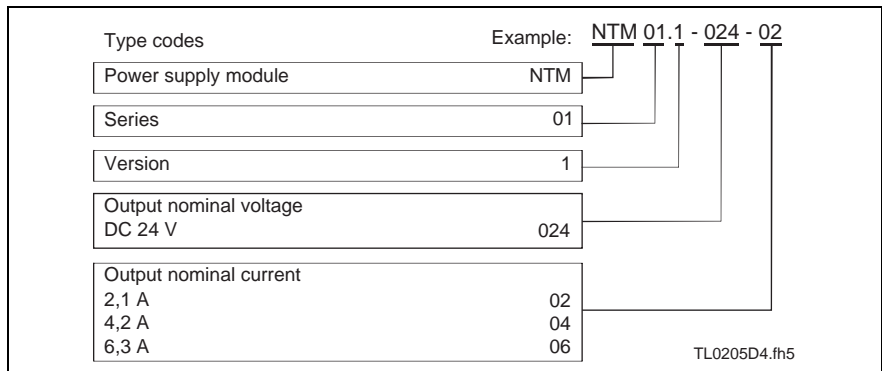

Fig. 7-7: Type code

8 NFD / NFE Mains Filter

8.1 Selection

The filters listed here are designed for the DKC drive controller power connection.

Please see Chapter 8.4, for details about the mains filter for interference suppression on the DC24V NTM power supply.

Max. mains connection voltage of the mains 50...60 Hz Un in V	Rated mains current (1) in A	No. of phases	Type of mains filter	Connection terminals			Brush shunt		Power dissipation W	Weight kg
				flexible mm ²	rigid mm ²	AWG	mm ²	AWG		
AC 480 V +10%	7,5	3	NFD 02.1-480-008	4	6	AWG 10	----		8,7	1,5
AC 480 V +10%	16	3	NFD 02.1-480-016	4	6	AWG 10	1,34	16	9	1,7
AC 480 V +10%	30	3	NFD 02.1-480-030	10	16	AWG 6	5,37	10	14	1,8
AC 480 V +10%	55	3	NFD 02.1-480-055	25	35	AWG 3	6	13,5	20	3,1
AC 480 V +10%	75	3	NFD 02.1-480-075	25	35	AWG 3	----	----	20	4
AC 480 V +10%	130	3	NFD 02.1-480-130	50	50	AWG 1/0	----	----	40	7,5
AC 480 V +10%	180	3	NFD 02.1-480-180	95	95	AWG 4/0	----	----	61	11
AC 230 V +10%	7,5	1	NFD 02.1-230-008	4	6	AWG 10	----	----	7,2	1,1

(1) = max. continuous powers in the main lines at an ambient temperature of 45°C

Fig. 8-1: Types of mains filters

Operating frequency	from DC to 60 Hz at 40 °C
Power Dissipation	measured 2 or 3 x RI ² _{Nenn} DC
Temperature range	-25...+85°C
Overload	1,5 I _{Nenn} 1 min per hour
Saturation reaction	Reduction of the filter attenuation by & dB at 2.5 to 3 times the rated current.
Test voltage	L/N -> PE or L -> PE: 2800 VDC 2s at 25°C L -> PE or L -> L: 2125 VDC 2s at 25°C
Reduction in current at over-temperatures	$I = I_N * \sqrt[2]{(85 - \Theta) / 40}$; Θ Ambient temperature in °C ; I _N referring to 45°C
Degree of protection	IP 10

Fig. 8-2: Technical specifications mains filter

8.2 Dimensional sheet and installation dimensions

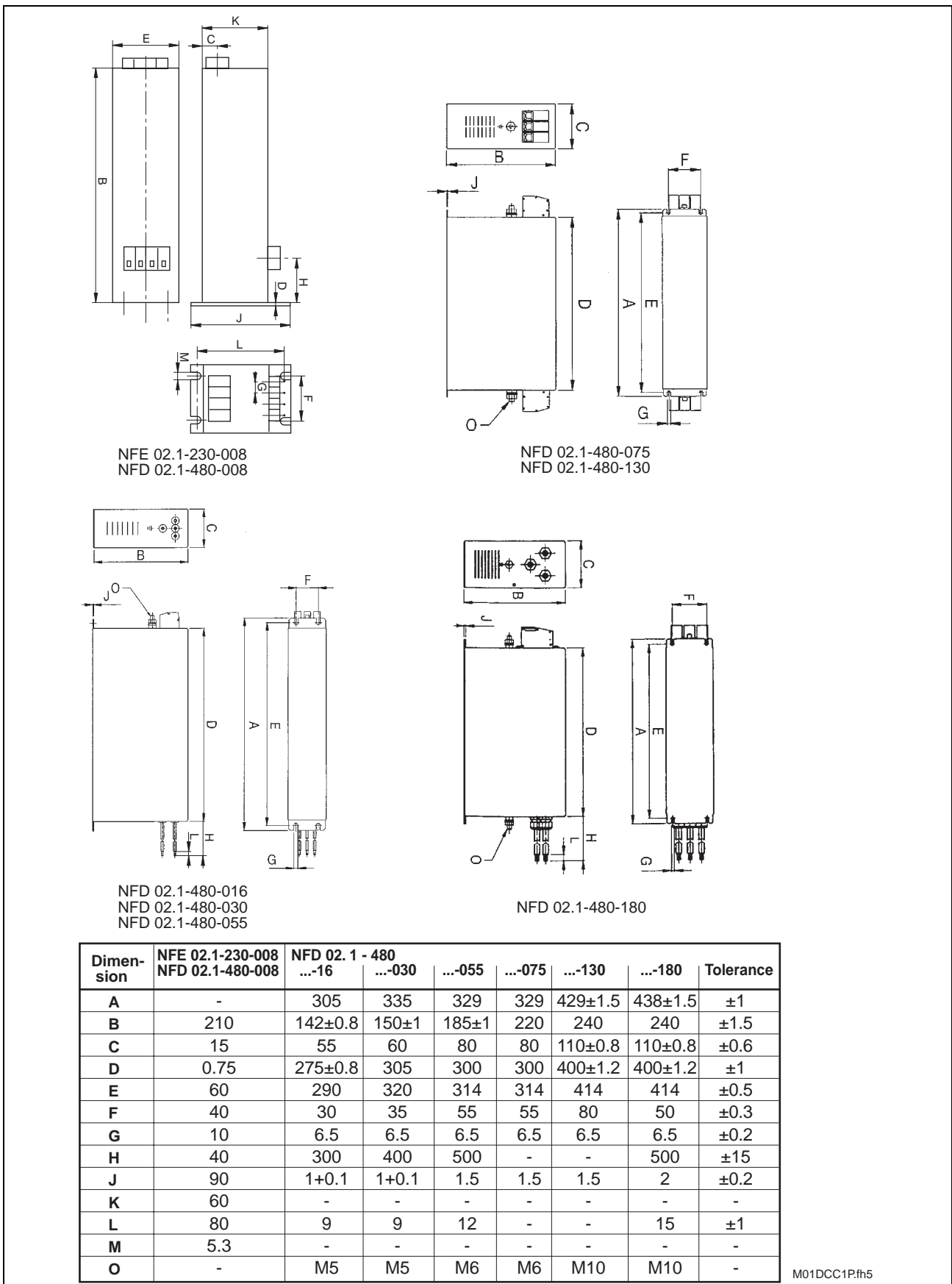

Fig. 8-3: Dimensional sheet ,installation dimensions of the NFD, NFE mains filters

Notes on Assembly

The mounting panel or the housing of the control cabinet to which the DKC is mounted are the preferred locations for assembly.



Live parts (greater than 50 V)!

Electric shock on contact!

- ⇒ Before startup operation, the protective earth conductor must first be permanently connected to the filter and then earthed!
- ⇒ Before touching bare connection cables and terminals, disconnect the filter and connected consumers from the mains or switch off unit. Allow time for discharging. Do not carry out work on connecting cables until then!
- ⇒ Due to the high discharge current of the filter, operation is not permitted without a connected protective conductor!
- ⇒ Thus, the filter may only be operated with a permanently connected protective conductor having a cross section $\geq 10 \text{ mm}^2$!
- ⇒ Remove any coats of paints from the mounting points of the filter.
- ⇒ Use a toothed lock washer with galvanised or tin-plated screws.

8.3 Electrical connection

Observe the recommendations made in the documentation "EMC in Drive and Control Systems" - Project Planning Manual, when mounting and installing the mains filter!

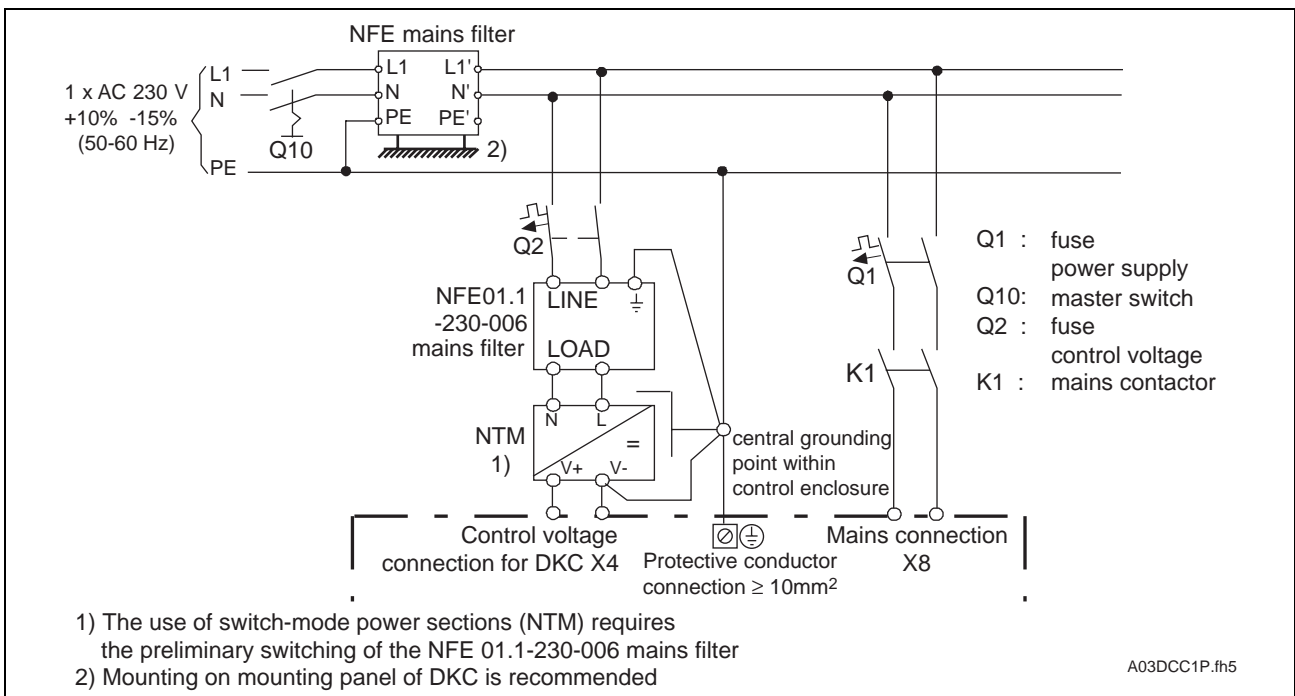

Fig. 8-4: Single-phase mains filter connection with NFE02.1-230-008

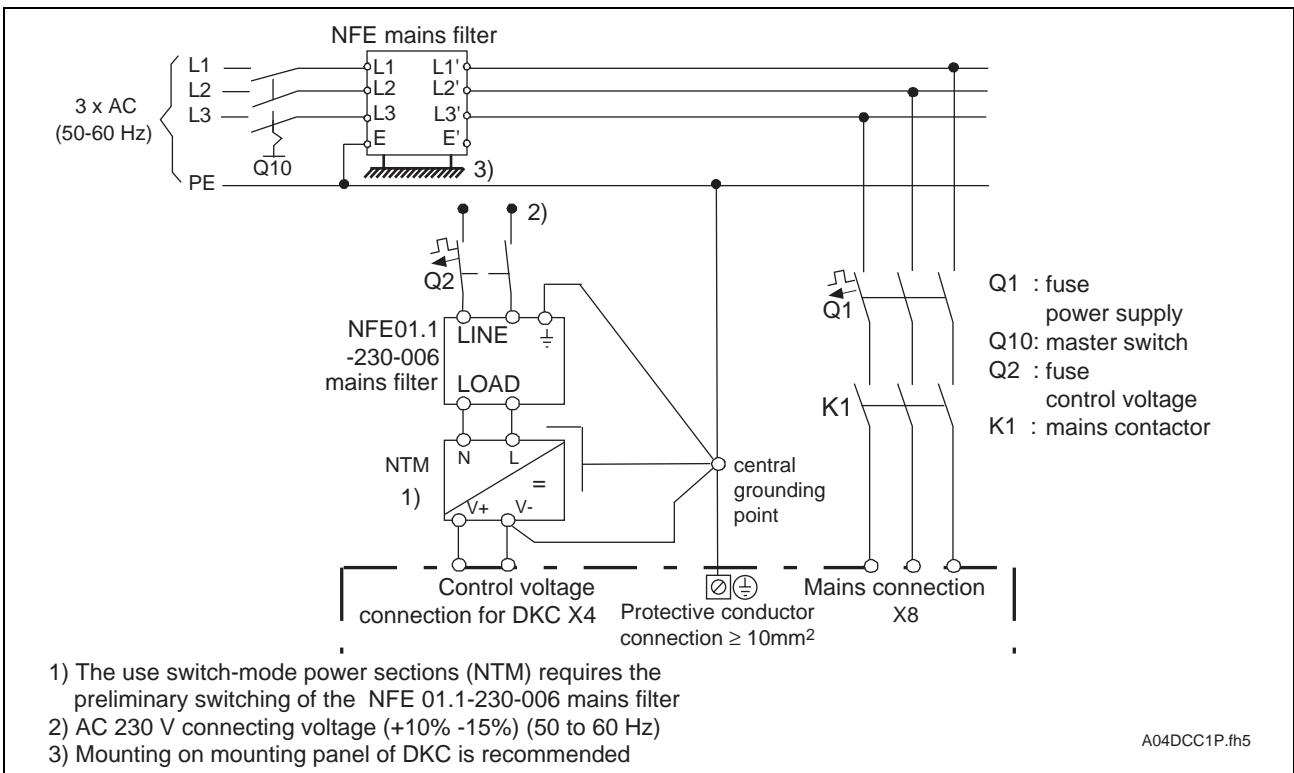

Fig. 8-5: Three-phase mains filter connection with NFD01.1 or NFD02.1

8.4 Mains Filter for DC24V NTM Power Supplies

When using an NTM, it is advisable to use the NFE01.1-250-006 mains filter for interference suppression.

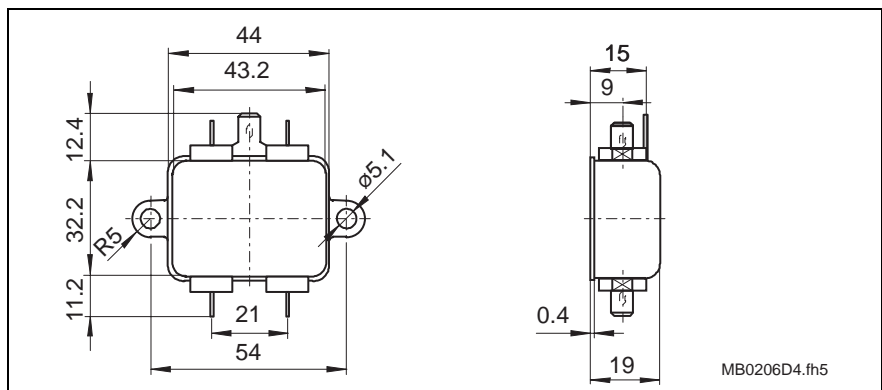

Fig. 8-6: Dimensional diagram: Mains filter NFE01.1-250-006

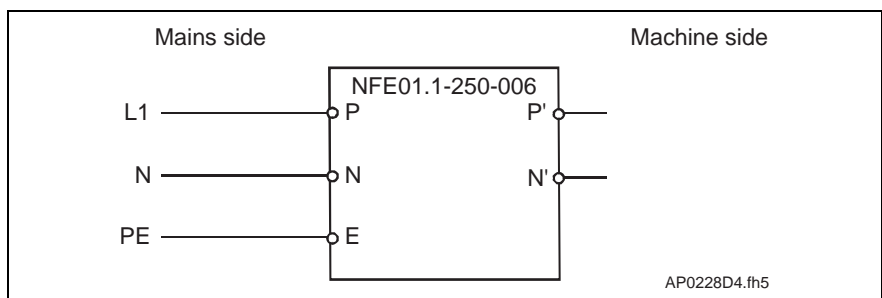

Fig. 8-7: Mains filter contact assignments NFE01.1-250-006

The mains filter is connected via 6.3-1 tab receptacles, as per DIN 462 545.

8.5 Type code

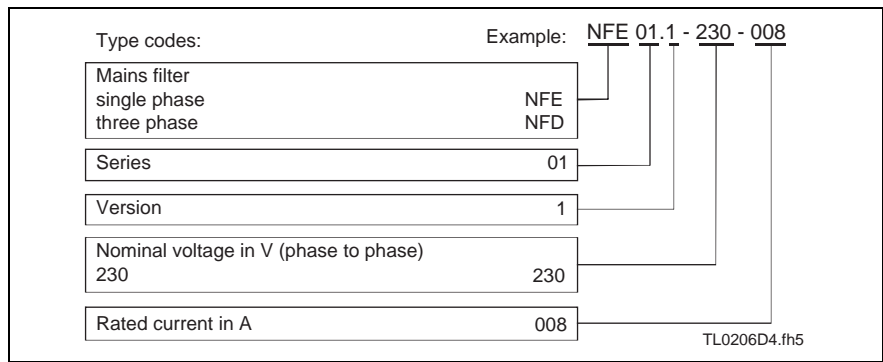

Fig. 8-8: Type code

Notes

9 DST / DLT Transformers

9.1 Selection

Transformers are only needed if the systems voltage exceeds the permitted rated voltage of the DKC.

Earthed mains With earthed mains, the mains voltage is matched to the rated voltage of the unit using autotransformers which are suitable for **this output voltage range** (see Fig. 9-1).

Unearthed mains To match the voltage with unearthed mains, always connect an isolating transformer to prevent overvoltages between the outer conductor and earth.

This documentation does not offer a product program to select suitable isolating transformers. (The documentation must be requested as needed).

9.2 Autotransformers for DKC^{**.*-040-7-FW}

Select an autotransformer suited to both the mains voltage and the power requirements of the plant.

Proceed with the selection as follows:

- ⇒ Determine the rating group using the required rated mains voltage range as shown in the diagram in Fig. 9-1, locate transformer ratio "i".
- ⇒ Calculate the actual transformer output voltage using the rated mains voltage and transformer ratio "i".
- ⇒ Check drive data. The output voltage of the transformer affects the drive data. See the documentation "ECODRIVE Servo Drives DKC with MKD"- Selection Data -.
- ⇒ Select a three-phase autotransformer using the required connected load.

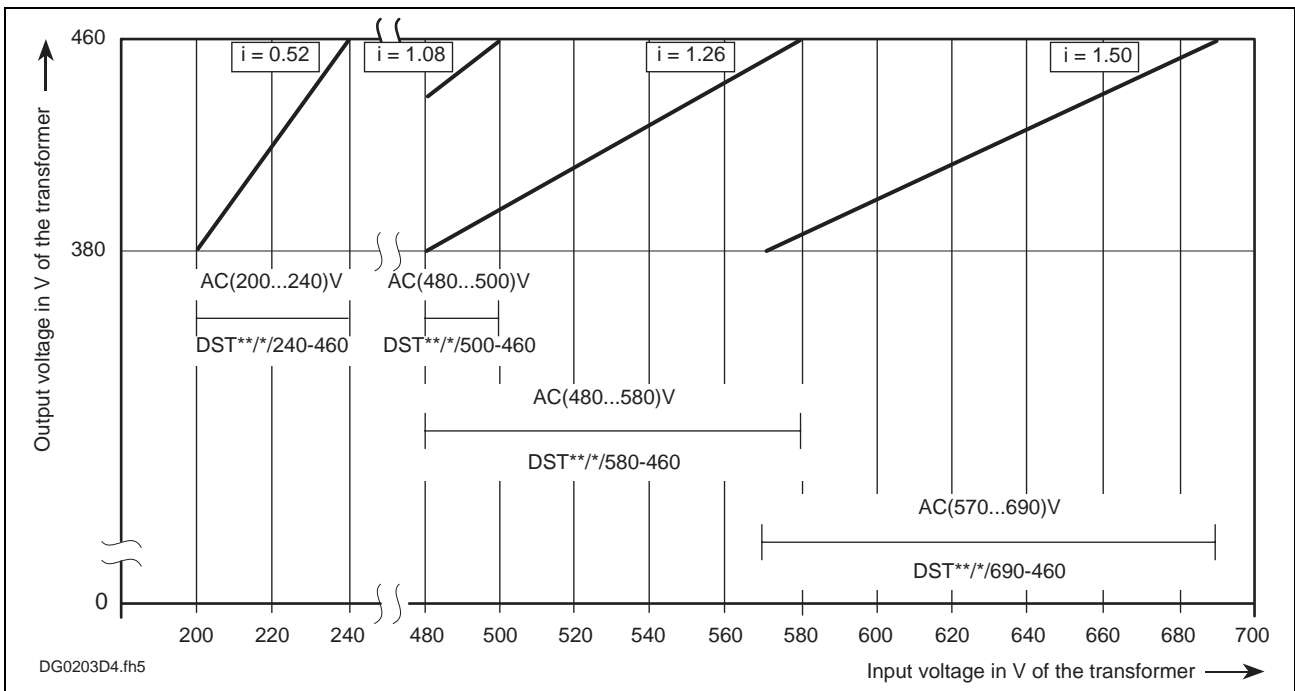
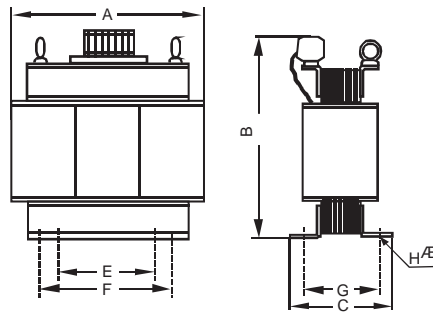

Fig. 9-1: Classification of three-phase autotransformers into types

DST autotransformer with secondary or output voltage AC (380 to 460) V

Standing version for mounting with base: DST.../S



Rating plate (example)

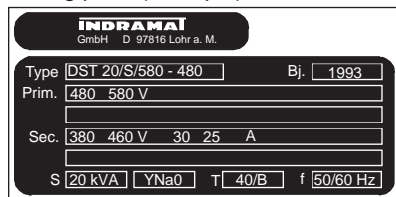

Block diagram

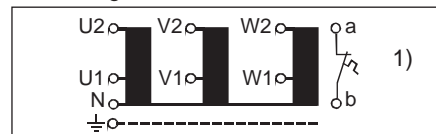

1) Temperature switch max. load:
DC 24V/1A; AC 230V/1A

Type designation DST...	Conn. output in KVA	Trans- mission ratio	Dimensions in mm							Power loss in W	max. conn. dia. in mm ²	Weight in kg
			A	C	B	F	E	G	H \varnothing			
Input voltage: AC (200...240) V $\pm 10\%$												
4/S/240-460	4		240	150	260	170	110	120	11	120	10	24.5
7,5/S/240-460	7.5		335	175	365	230	160	145	11	225	10	55
12,5/S/240-460	12.5	0.52	360	190	395	250	170	160	11	310	10	70
25/S/240-460	25		480	195	500	356	-----	158	13	500	35	135
50/S/240-460	50		580	265	540	400	270	215	18	750	70	195
Input voltage: AC (480...500) V $\pm 10\%$												
4/S/500-460	4		180	105	190	125	80	75	7	160	4	8.5
7,5/S/500-460	7.5		205	130	210	145	95	95	7	260	4	13
12,5/S/500-460	12.5	1.08	240	140	260	170	110	110	11	440	10	22
25/S/500-460	25		300	155	325	210	140	125	11	750	16	36
50/S/500-460	50		335	175	365	230	160	145	11	1050	35	53
Input voltage: AC (480...580) V $\pm 10\%$												
4/S/580-460	4		240	130	260	170	110	100	11	140	4	18
7,5/S/580-460	7.5		240	140	260	170	110	110	11	260	4	22
12,5/S/580-460	12.5	1.26	300	155	325	210	140	125	11	375	10	37
25/S/580-460	25		360	190	395	250	170	160	11	625	10	72
50/S/580-460	50		420	215	450	280	190	155	14	1000	35	95
Input voltage: AC (570...690) V $\pm 10\%$												
4/S/690-460	4		240	140	260	170	110	110	11	140	10	22
7,5/S/690-460	7.5		300	155	325	210	140	125	11	225	10	37
12,5/S/690-460	12.5	1.5	335	175	365	230	160	145	11	375	10	57
25/S/690-460	25		420	205	450	280	190	145	14	500	16	88
50/S/690-460	50		480	222	500	356	-----	185	13	750	35	178

MB0207D4.fh5

Fig. 9-2: DST autotransformers on DKC**.1-40-7-FW for matching system voltage

9.3 Electrical connections of the DKC using a transformer

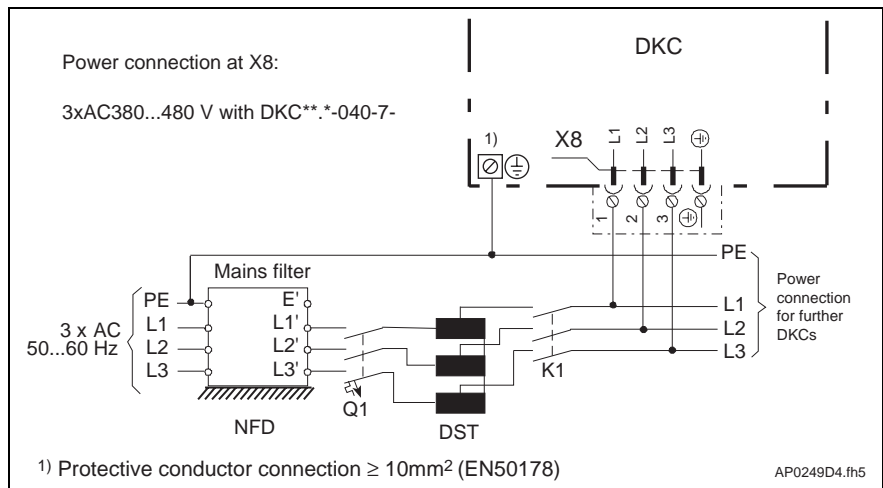

Fig. 9-3: Mains connection with three-phase autotransformer

9.4 Type code

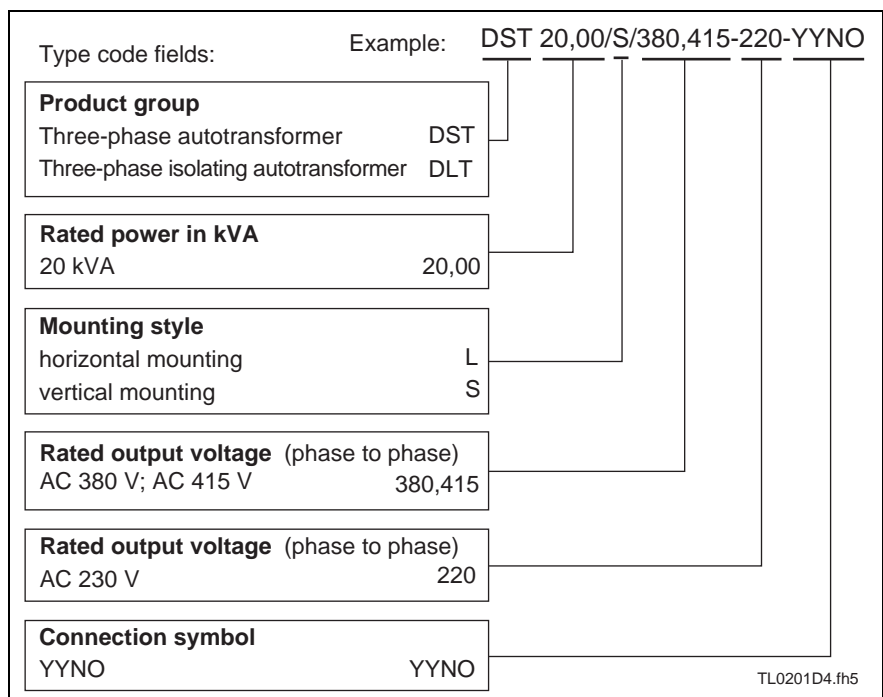

Fig. 9-4: Type code for transformers

10 Planning the Control cabinet Construction

10.1 Notes on installing the control cabinet

All ECODRIVE drive components -- with the exception of the motors -- are designed to be installed into a control cabinet. When planning the control cabinet, it is necessary to take the technical specifications of the drive components into account.

Power dissipation

Power dissipation is determined by the current load and the continuous regenerative power. The actual power dissipation is dependent on the respective cycle load. The servomotor has been designed for this load cycle.

On the average, the maximum continuous current at standstill I_{dN} will flow through the drive controller.

Determining power dissipation

- ⇒ Locate the amount of continuous current at standstill I_{dN} listed in the motor documentation. See the respective documentation "ECODRIVE servomotors MKD" - Project Planning Manual.
- ⇒ Using the I_{dN} value of the motor selected, find the value in the diagram in Fig. 10-1 for the current-dependent power dissipation $P_{V,DKC}$.
- ⇒ Convert the continuous regenerative power found in table Fig. 3-1 with the factor 0.8. This is the power dissipated by the bleeder $P_{V,Bleeder}$ in the DKC.
- ⇒ Add both dissipation values ($P_{V,DKC}$ and $P_{V,Bleeder}$). Use the total ($P_{V,ges}$) for planning the control cabinet.

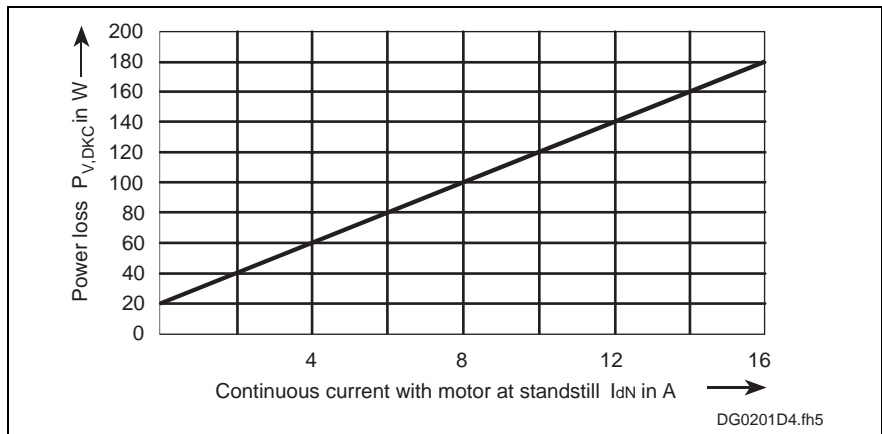

Fig. 10-1: Determining the power dissipated in the control cabinet

10.2 Using heat-exchanger units in the control cabinets

Improperly installed and operated heat-exchanger units represent a risk to the drive components installed in the control cabinet due to the moisture condensation and condensed water which these may cause!

Risk of moisture condensation Humid air enters the control cabinet and, as it cools, condenses onto the installed drive components.

Risk of condensation water If the heat-exchanger unit is not properly situated in the control cabinet, the continuously condensed water can drip into the installed drive components or be sprayed into them by the cold air current.

Avoiding moisture condensation

Properly using heat-exchanger units:

- When using heat heat-exchanger units, the control cabinets must be well sealed so that moisture cannot form caused by humid outside air entering the control cabinets!
- In the event that the control cabinets are operated with open doors (initial operation, servicing, etc.), ensure that the drive components, after the doors have been closed, are never cooler than the air in the control cabinets. Otherwise, moisture condensation may occur. For this reason, it is important that the heat-exchanger unit continues to operate when the plant has been shut down to ensure that the temperature within the control cabinet does not deviate from that of the drive components.
- Set the heat-exchanger unit temperature permanently to 40 °C. Not lower!
- Heat-exchangers with follow-up temperature must be set so that the temperature inside the control cabinet is never lower than the outside temperature. Set the temperature limit to 40 °C!

Avoiding dripping and sprayed water

The heat-exchanger units must be arranged in such a way that condensed water cannot fall into the installed drive components. Units on top of the control cabinet require a special design!

Make sure that the control cabinet is constructed in such a way that the blower of the cooling unit cannot spray condensed water which may have collected on the drive components!

Summary

- Make sure that no condensed water can drip into the installed drive components!
- Ensure that the temperature of the heat-exchanger unit has been properly set!

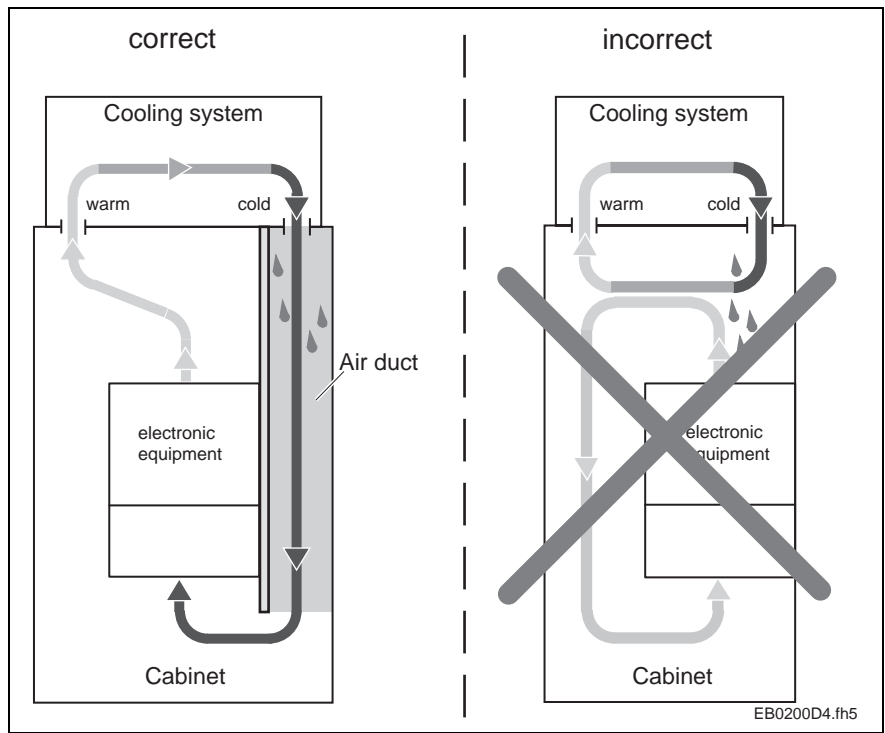

Fig. 10-2: Arranging the heat-exchanger unit on the top of the control cabinet

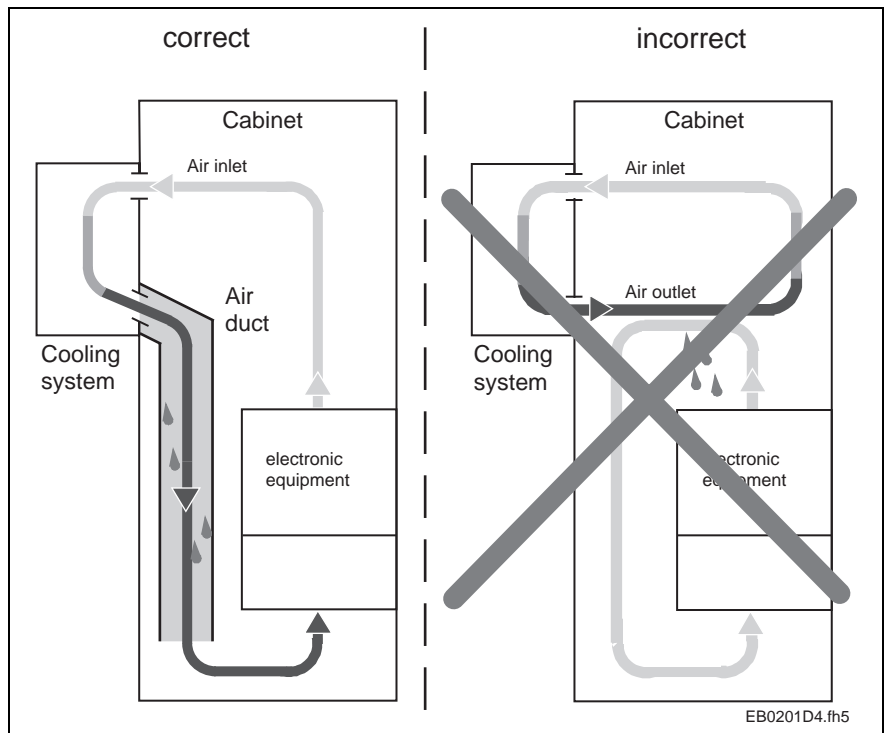

Fig. 10-3: Arranging the heat-exchanger unit on the front of the control cabinet

Notes

11 Power Connection

11.1 Direct mains connection

DKC.1-040-7-FW**

It is possible to connect these drives directly to earthed three-phase systems with AC 380...480 V, ±10 %. Only fuse protection Q1, a mains contactor K1, and normally a mains filter are required in the mains input line.

If the mains voltage exceeds the permitted input voltage range, then the voltage must be matched by means of an autotransformer which, in turn, has also been designed for a specified voltage range (see Chapter 9-1).

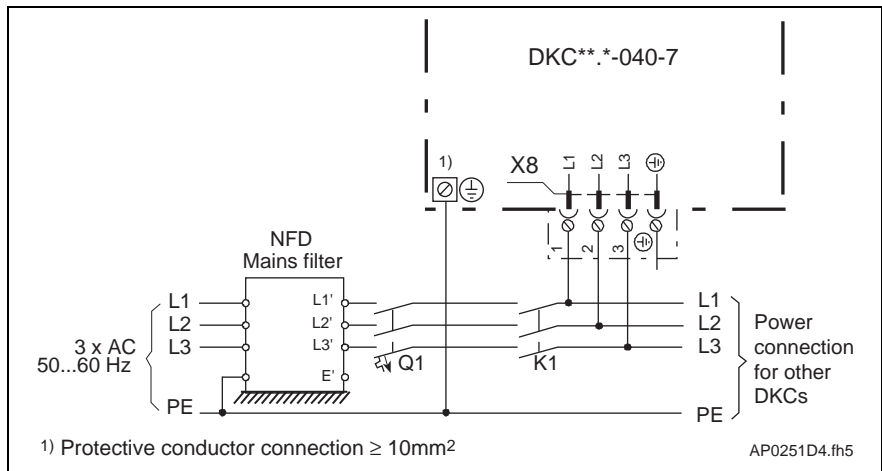

Fig. 11-1: Direct three-phase mains connection

11.2 Mains contactor/fuse protection

A selection table (Fig. 11-5) is available to facilitate the selection of a suitable mains contactor and fuse protection for the power connection.

Calculating the phase current at the mains

To be able to select a suitable mains contactor and suitable power connection fuse protection, the phase current I_N at the mains must first be calculated.

The apparent power S is used to determine the mains phase current I_N .

Use the apparent power in the selection table of the drive components, or calculate it according to formula Fig. 11-3. For several drive controllers, add the individual apparent power values.

$$P_{DC} = \frac{M_{EFF} \cdot n_{MITTEL} \cdot 2\pi}{60} \cdot k$$

P_{DC} : DC bus power in W
 M_{EFF} : Effective torque in Nm
 n_{MITTEL} : Average speed in min^{-1}
 k : Factor for motor and controller efficiency = 1.25

Fig. 11-2: Calculating the DC bus power

$$S_{AN} = P_{DC} \cdot F$$

F : Factor for the connected load
 F : 2.6 for $P_{DC} = 500 \text{ W}$
 F : 1.95 for $P_{DC} = 2000 \text{ W}$

Fig. 11-3: Berechnung der Netzanschußleistung

Three-phase connection:
$$I_N = \frac{S_{AN}}{U_N \cdot \sqrt{3}}$$

I_N : Phase current at mains in A
 S_{AN} : Mains connection power in VA
 U_N : Voltage between the phases of the system in V

Fig. 11-4: Calculating the phase current at the mains

Selecting fuse protection Q1 and mains contactor K1

Fuse protection Q1 The fuse protection must be rated 1.5 times higher than the actual mains current I_N .

Fuse protection can be implemented using:

- an automatic circuit breaker (power circuit breaker) or
- a power circuit breaker or
- safety fuses.

Mains contactor K1 Select the mains contactor according to the phase current at the mains and the rated mains voltage.

The rated current of the mains contactor must be 1.5 times higher than the actual phase current at the mains.

For a rated mains voltage of 3 x 400 V, 50 Hz, , the mains contactors listed in the selection table are recommended depending on the phase current I_N .

Selection table The types specified in the selection table are from Siemens Corp. and are used as examples. Similar products from other manufacturers can also be used.

Phase current I_N in A	Line cross section (1) mm ²	Recommended fuse protection							Recommended mains contactor		
		Automatic circuit breaker (tripping charact. C)		Power circuit breaker			Safety fuse (class gl)		(for $U_N = 3 \times 400 \text{ V}$, 50 Hz)		
		Current in A	N (3)	Siemens type	Set value in A	N (3)	Current in A	N (3)	Siemens type	Nominal operating current	N (3)
to 8.7	1,0	10	5	3VU1300 -.ML00	10	12	10	4	3TF40	12	7
to 11	1,5	16	7	3VU1300 -.MM00	16	19	16	6	3TF41	16	10
to 15	2,5	20	9	3VU1300 -.MP00	20	24	20	9	3TF42	22	13
to 21	4,0	32	15	3VU1300 -.MP00	25	30	32	14	3TF43	32	19

(1) Values apply to PVC insulated multi-wire cables in protective pipes and installation ducts with an ambient temperature of 45 °C (per EN 60204-1/1992)

(2) The current was fixed based on operating mode AC 3 for a mains voltage of AC 400 V, 50 Hz.

(3) N = maximum number of connectable drives taking the starting current into consideration. If more drives are connected than indicated, a fuse or mains contactor with a higher current rating must be selected.

Fig. 11-5: Selection table for fuse protection Q1 and mains contactor K1

11.3 Control circuit to the power connection

The control circuit recommended by INDRAMAT specifies the function principle.

The choice of interface unit and its efficiency depends on the range of functions and the course of efficiency of the entire plant or machine. Therefore, it is the manufacturer's responsibility to make this choice.

Emergency stop

The input is used to monitor communication between a connected control and the DKC03.1. In the event of an error, a parameterized drive reaction is actuated. The units are delivered with activated emergency stop, i.e. 24V must be present at the input when the DKC is put into operation. Only then will the ready contact close. Removing the 24V will lead to an error message.

Signal contact ready for operation Bb

The ready to operate message is output over a relay contact (make contact). If the ready to operate contact Bb closes, the drive is then ready for input power. It is thus used as a condition for connecting the mains contactor (see Fig. 11-6)

Note: The direct contactor connection via the Bb contact is permitted. The permitted contact load must be met.

Switching states

The Bb contact opens when:

- the control voltage for the DKC is not present,
- 24 V are not present at the emergency stop input or
- if there are faults in the drive.

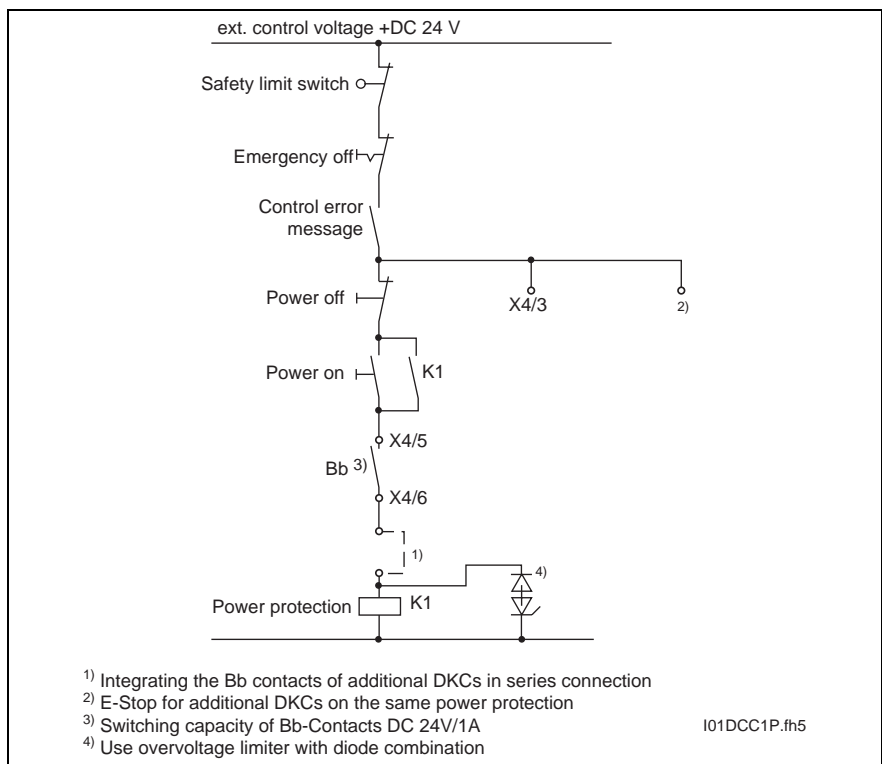

Fig. 11-6: Principal control switch to the DKC

11.4 Protection against indirect contact

As a result of the high capacitive leakage currents via the cable insulation, it is not possible to install a current operated ELCB. device into the power supply line (compliant to DIN VDE 0160, section 6.5).

Thus, protection against indirect contact must be achieved by other means.

The drive system components have a protective earthed housing. This makes protection against indirect contact with the protective multiple earthing possible.

12 Preparing for Initial Startup

Required equipment

The following equipment is necessary for startup operation of an ECODRIVE drive system:

- measuring instruments
- a personal computer (PC)
- connecting cables (PC-DKC)
- a PLC with PROFIBUS-DP (master)

Measuring instruments

The following measuring instruments are required so that torque, current and speed can be measured as analog signals at the analog outputs:

- a multimeter for measuring voltage (sufficient for series startup operation) and
- an oscilloscope or recorder (only needed for recording the signal sequences during startup operation for prototypes).

Personal Computer (PC)

The PC is needed for programming, parameterization and diagnostics during startup and servicing operations.

Hardware requirements:

- IBM compatibility
- 80386-SX microprocessor (80486 recommended)
- at least 4 MB RAM memory (8 MB recommended)
- harddisk with at least 2.5 MB of free storage space
- 3.5" floppy disk drive with a capacity of 1.44 MB
- one free serial RS-232 interface in the PC (COM 1 or COM 2)
- an EGA monitor or monitor with higher resolution
- a mouse or compatible pointing device

Software requirements:

- The operating system DOS 5.0 or higher
- Windows 3.1 or higher
- DriveTop startup program (floppy disk is included with ECODRIVE)

Connecting cables (PC-DKC)

To connect a PC with a 9-pin D-SUB connector, use cable type IKS101.
To connect a PC with a 25-pin D-SUB connector, use cable type IKS102.
Pin assignment of the cable Fig. 4-14.

Notes

13 Delivery Condition of the Drive Components

Packaging

- Packaging units** ECODRIVE components are delivered in separate packaging units. Accessories are fastened to the unit.
- Packaging materials** INDRAMAT will take back packaging materials free of charge. The customer is liable for return transport costs.
- Packaging labels** The barcode label on the packaging identifies the enclosed components and order number.

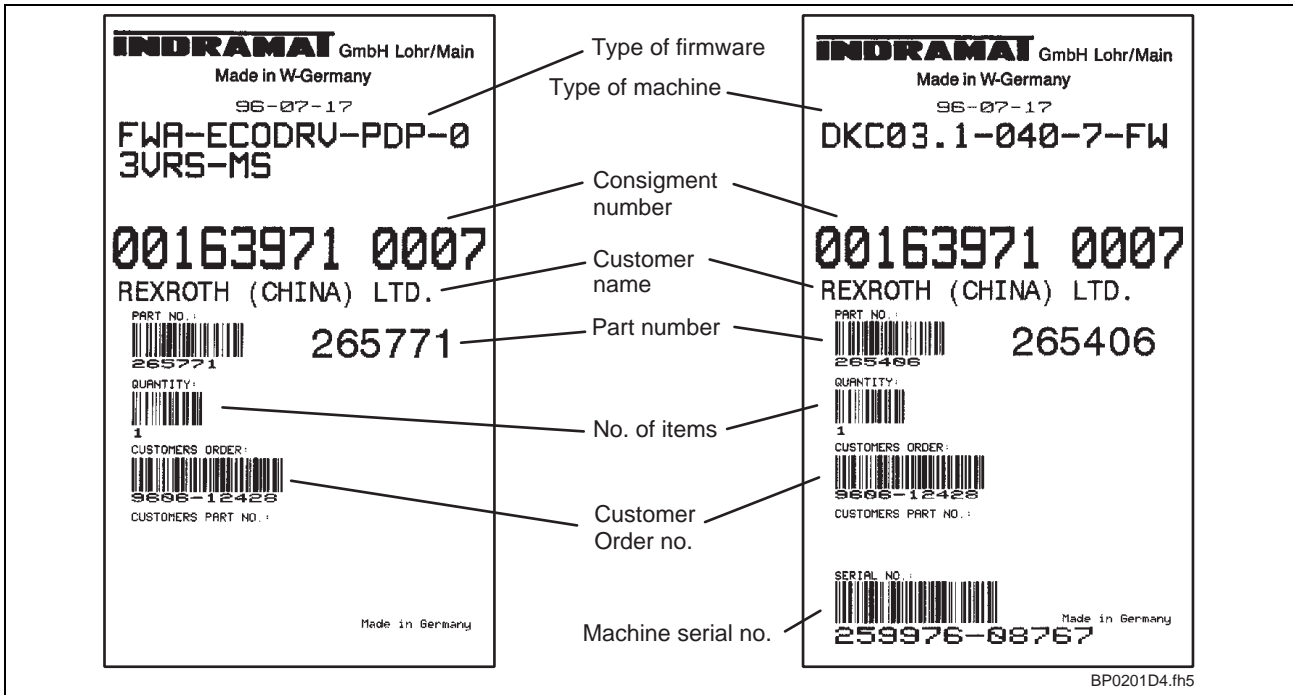

Fig. 13-1: Structure of the barcode label on the packaging

Shipping documents

One of the delivered packages has an envelope attached to it containing a delivery note in duplicate. These are the only shipping documents unless special arrangements were made when the order was placed.

Either the delivery note or the freight papers will list the total number of packages or transport containers included in the shipment.

Identification of the components

- Each drive component is identified by a type designation.
- There is a rating plate on all pieces of equipment, including the motor.
- A label (cable tag) is wrapped around the ready-made cable. The type designation and the length is indicated on the label. The actual cable designation -- without connector-- is printed on the cable sheath.
- The accessories packed in bags are identified either by a printed label on the bags or by an additional enclosed slip.

Notes

14 Index

A

Autotransformer 9-1

B

Bus connector 4-16

C

Condensation 10-2

Connecting cable 4-16

Connecting terminals 4-7

Continuous regenerated power
5-1, 5-2, 5-3, 5-4

Control switch 11-4

D

DC bus capacitance 6-1

DC bus connection 4-15

DC24V Power supply 4-2

Diagnostic Outputs 4-14

Dimensional sheet and installation
dimensions 6-3

Drive control words 4-15

Drive status word 11-5

Drive status words 4-15

E

Earthed mains 9-1

Emergency stop 4-14, 11-4

F

Firmware 4-6

Fuse protection Q1 11-2, 11-3

Fuse protection Q2 7-1

M

Mains connection 11-1

Mains contactor K1 11-3

Measuring instruments 12-1

P

Packaging 13-1

Packaging labels 13-1

Peak regenerative power 5-1

Phase current at the mains 11-2

Power dissipation 10-1

PROFIBUS-DP connection 4-8, 4-15

R

Ready for operation Bb 11-4

Regenerative energy 5-1

Rotary energy 6-1

RS-232 interface 4-9

RS-485 interface 4-10

S

Sensor inputs 4-13

Serial bus 4-10

Shipping documents 13-1

Single-phase mains filter connection 8-3

Slave 4-18

Storable energy 6-1

Switch-on sequence 11-5

T

Terminator 4-16

Three-phase mains filter connection 8-4

Transformers 9-1

Travel range limit switches 4-13

Two-wire cable 4-18

U

Unearthed mains 9-1

Notes

Directory of customer service locations

Germany

Sales Region Central INDRAMAT GmbH D-97816 Lohr am Main Bgm.-Dr.-Nebel-Str. 2 Telephone: 09352/40-0 Telefax: 09352/40-4885	Sales Region East INDRAMAT GmbH D-09120 Chemnitz Beckerstraße 31 Telephone: 0371/3555-0 Telefax: 0371/3555-230	Sales Region West INDRAMAT GmbH D-40849 Ratingen Hansastraße 25 Telephone: 02102/4318-0 Telefax: 02102/41315	Sales Region North INDRAMAT GmbH D-22085 Hamburg Fährhausstraße 11 Telephone: 040/227126-16 Telefax: 040/227126-15
Sales Region South INDRAMAT GmbH D-80339 München Ridlerstraße 75 Telephone: 089/540138-30 Telefax: 089/540138-10	Sales Region Southwest INDRAMAT GmbH D-71229 Leonberg Böblinger Straße 25 Telephone: 07152/972-6 Telefax: 07152/972-727		INDRAMAT Service Hotline INDRAMAT GmbH Telephone: D-0172/660 040 6 -oder- Telephone: D-0171/333 882 6

Customer service locations in Germany

Europe

Austria G.L.Rexroth Ges.m.b.H. Geschäftsbereich INDRAMAT A-1140 Wien Hägelingasse 3 Telephone: 1/9852540-400 Telefax: 1/9852540-93	Austria G.L.Rexroth Ges.m.b.H. Geschäftsbereich INDRAMAT A-4061 Pasching Randlstraße 14 Telephone: 07229/64401-36 Telefax: 07229/64401-80	Belgium Mannesmann Rexroth N.V.-S.A. Geschäftsbereich INDRAMAT B-1740 Ternat Industrielaan 8 Telephone: 02/5823180 Telefax: 02/5824310	Denmark BEC Elektronik AS DK-8900 Randers Zinkvej 6 Telephone: 086/447866 Telefax: 086/447160
England Mannesmann Rexroth Ltd. INDRAMAT Division Cirencester, Glos GL7 1YG 4 Esland Place, Love Lane Telephone: 01285/658671 Telefax: 01285/654991	Finnland Rexroth Mecman OY SF-01720 Vantaa Riihimiehentie 3 Telephone: 0/848511 Telefax: 0/846387	France Rexroth - Sigma S.A. Division INDRAMAT F-92632 Gennevilliers Cedex Parc des Barbanniers 4, Place du Village Telephone: 1/41475430 Telefax: 1/47946941	France Rexroth - Sigma S.A. Division INDRAMAT F-69634 Venissieux - Cx 91, Bd 1 Joliot Curie Telephone: 78785256 Telefax: 78785231
France Rexroth - Sigma S.A. Division INDRAMAT F-31100 Toulouse 270, Avenue de Iardenne Telephone: 61499519 Telefax: 61310041	Italy Rexroth S.p.A. Divisione INDRAMAT I-20063 Cernusco S/N.MI Via G. Di Vittoria, 1 Telephone: 02/92365-270 Telefax: 02/92108069	Italy Rexroth S.p.A. Divisione INDRAMAT Via Borgomanero, 11 I-10145 Torino Telephone: 011/7712230 Telefax: 011/7710190	Netherlands Hydraudyne Hydrauliek B.V. Kruisbroeksestraat 1a P.O. Box 32 NL-5280 AA Boxtel Telephone: 04116/51951 Telefax: 04116/51483
Spain Rexroth S.A. Centro Industrial Santiago Obradors s/n E-08130 Santa Perpetua de Mogoda (Barcelona) Telephone: 03/718 68 51 Telex: 591 81 Telefax: 03/718 98 62	Spain Goimendi S.A. División Indramat Jolastokieta (Herrera) Apartado 11 37 San Sebastian, 20017 Telephone: 043/40 01 63 Telex: 361 72 Telefax: 043/39 93 95	Sweden AB Rexroth Mecman INDRAMAT Division Varuvägen 7 S-125 81 Stockholm Telephone: 08/727 92 00 Telefax: 08/64 73 277	Switzerland Rexroth SA Département INDRAMAT Chemin de l'Ecole 6 CH-1036 Sullens Telephone: 021/731 43 77 Telefax: 021/731 46 78
Switzerland Rexroth AG Geschäftsbereich INDRAMAT Gewerbestraße 3 CH-8500 Frauenfeld Telephone: 052/720 21 00 Telefax: 052/720 21 11	Russia Tschudnenko E.B. Arsenia 22 153000 Ivanovo Rußland Telephone: 093/22 39 633		

Other European customer service locations

Other international locations

<p>Argentina</p> <p>Mannesmann Rexroth S.A.I.C. Division INDRAMAT Acassusso 48 41/7 1605 Munro (Buenos Aires) Argentina</p> <p>Telephone: 01/756 01 40 01/756 02 40 Telex: 262 66 rexro ar Telefax: 01/756 01 36</p>	<p>Argentina</p> <p>Nakase Asesoramiento Tecnico Diaz Velez 2929 1636 Olivos (Provincia de Buenos Aires) Argentina Argentina</p> <p>Telephone 01/790 52 30</p>	<p>Australia</p> <p>Australian Industrial Machinery Services Pty. Ltd. Unit 3/45 Horne ST Campbellfield VIC 2061 Australia</p> <p>Telephone: 03/93 59 0228 Telefax: 03/93 59 02886</p>	<p>Brazil</p> <p>Mannesmann Rexroth Automação Ltda. Divisão INDRAMAT Rua Georg Rexroth, 609 Vila Padre Anchieta BR-09.951-250 Diadema-SP Caixa Postal 377 BR-09.901-970 Diadema-SP</p> <p>Telephone: 011/745 90 65 011/745 90 70 Telefax: 011/745 90 50</p>
<p>Canada</p> <p>Basic Technologies Corporation Burlington Division 3426 Mainway Drive Burlington, Ontario Canada L7M 1A8</p> <p>Telephone: 905/335-55 11 Telefax: 905/335-41 84</p>	<p>China</p> <p>Rexroth (China) Ltd. Shanghai Office Room 206 Shanghai Intern. Trade Centre 2200 Yanan Xi Lu Shanghai 200335 P.R. China</p> <p>Telephone: 021/627 55 333 Telefax: 021/627 55 666</p>	<p>China</p> <p>Rexroth (China) Ltd. Shanghai Parts & Service Centre 199 Wu Cao Road, Hua Cao Minhang District Shanghai 201 103 P.R. China</p> <p>Telephone: 021/622 00 058 Telefax: 021/622 00 068</p>	<p>China</p> <p>Rexroth (China) Ltd. 1430 China World Trade Centre 1, Jianguomenwai Avenue Beijing 100004 P.R. China</p> <p>Telephone: 010/50 50 380 Telefax: 010/50 50 379</p>
<p>China</p> <p>Rexroth (China) Ltd. A-5F., 123 Lian Shan Street Sha He Kou District Dalian 116 023 P.R. China</p> <p>Telephone: 0411/46 78 930 Telefax: 0411/46 78 932</p>	<p>Honkong</p> <p>Rexroth (China) Ltd. 19 Cheung Shun Street 1st Floor, Cheung Sha Wan, Kowloon, Honkong</p> <p>Telephone: 741 13 51-54 und 741 14 30 Telex: 3346 17 GL REX HX Telefax: 786 40 19 786 07 33</p>	<p>India</p> <p>Mannesmann Rexroth (India) Ltd. INDRAMAT Division Plot. 96, Phase III Peenya Industrial Area Bangalore - 560058</p> <p>Telephone: 80/839 21 01 80/839 73 74 Telex: 845 5028 RexB Telefax: 80/839 43 45</p>	<p>Japan</p> <p>Rexroth Co., Ltd. INDRAMAT Division I.R. Building Nakamachidai 4-26-44 Tsuzuki-ku, Yokohama 226 Japan</p> <p>Telephone: 045/942-72 10 Telefax: 045/942-03 41</p>
<p>Korea</p> <p>Rexroth-Seki Co Ltd. 1500-12 Da-Dae-Dong Saha-Gu, Pusan, 604-050</p> <p>Telephone: 051/264 90 01 Telefax: 051/264 90 10</p>	<p>Korea</p> <p>Seo Chang Corporation Ltd. Room 903, Jeail Building 44-35 Yoido-Dong Youngdeungpo-Ku Seoul, Korea</p> <p>Telephone: 02/780-82 07 -9 Telefax: 02/784-54 08</p>	<p>Mexico</p> <p>Motorización y Diseño de Controles, S.A. de C.V. Av. Dr. Gustavo Baz No. 288 Col. Parque Industrial la loma Apartado Postal No. 318 54060 Tlalnepantla Estado de Mexico</p> <p>Telephone: 5/397 86 44 Telefax: 5/398 98 88</p>	
<p>USA</p> <p>Rexroth Corporation INDRAMAT Division 5150 Prairie Stone Parkway Hoffman Estates, Illinois 60192</p> <p>Telephone: 847/645-36 00 Telefax: 857/645-62 01</p>	<p>USA</p> <p>Rexroth Corporation INDRAMAT Division 2110 Austin Avenue Rochester Hills, Michigan 48309</p> <p>Telephone: 810/853-82 90 Telefax: 810/853-82 90</p>		

Other international customer service locations

Notes

