

Compax3 Installation Manual

Single axis devices

Paper version



192-120102 N7 - February 2004

- 890-130001 Compax3
 Unterlagen / Software
 user guides / tools
 manuels / tools:
- ◆ Compax3 - CD (english, deutsch, français)
 - +
 - ◆ Compax3 Installations-Handbuch deutsch
 - ◆ Compax3 Installation Manual english
 - ◆ Manuel technique Compax3 français

Release 1/2004 (as from firmware V2.03)

Copyright © 2003 Parker Hannifin GmbH EME
All rights reserved.

Microsoft Word, Microsoft Office, Windows®, Window 95™, Window 98™, Windows NT®, Window 2000™, Window XP™ and MS-DOS™ are trademarks of Microsoft Corporation.

EME - Electromechanical Automation Europe

Germany: Parker Hannifin GmbH
Electromechanical Automation
Postfach: 77607-1720
Robert-Bosch-Str. 22
D-77656 Offenburg
Tel.: +49 (0)781 509-0
Fax: +49 (0)781 509-176

E-mail: sales.hauser@parker.com mailto:sales.hauser@parker.com

Internet: www.parker-eme.com http://www.parker-eme.com

England: Parker Hannifin plc
Electromechanical Automation
21 Balena Close
Poole, Dorset England, BH17 /DX UK
Tel.: +44 (0)1202 69 9000
Fax: +44 (0)1202 69 5750

E-mail: sales.digiplan@parker.com mailto:sales.digiplan@parker.com

Internet: www.parker-eme.com http://www.parker-eme.com

Italy: Parker Hannifin S. p. A
Electromechanical Automation
Via Gounod 1
I-20092 Cinisello Balsamo (MI), Italy
Tel.: +39 (0)2660 12459
Fax: +39 (0)2660 12808

E-mail: sales.sbc@parker.com mailto:sales.sbc@parker.com

Internet: www.parker-eme.com http://www.parker-eme.com

EMN - Electromechanical Automation North America

USA: Parker Hannifin Corporation
Electromechanical Automation
5500 Business Park Drive
Rohnert Park, CA 94928
Phone #: (800) 358-9068
FAX #: (707) 584-3715

E-mail: CMR_help@parker.com mailto:CMR_help@parker.com

Internet: www.compumotor.com http://www.compumotor.com

1. Notes on the Documents Supplied

Compax3 – Installation manual The present manual contains the installation instructions for the associated Compax3 device series (refer to Chapter “Device Assignment”).

Compax3 CD

C3 ServoManager The enclosed self-starting* CD contains the “C3 ServoManager” software tool for configuring, optimizing etc. Compax3.
Please use always the latest C3 ServoManager version, which can be found on the latest Compax3 CD enclosed.

Online help system The installation of ServoManager also copies an online help system to your PC that can be started directly from ServoManager. You will find the complete description of the selected device type in these online help files.

Manuals The CD also contains additional help files as well as manuals in PDF format that can be printed to compile a complete hardcopy version of the respective manual.
Please note that the help files and the manuals are associated with defined device and software versions.

Catalogs The catalogs supplied provide an overview of and information on the Compax3 device series.

Adobe Acrobat Reader® The "Adobe Acrobat Reader®" is also included on the CD. It is free software that lets you view and print "Adobe Portable Document Format" (PDF) files and it is distributed and generally accepted throughout the world. You can also download it directly from the Adobe website at: www.adobe.com/products/acrobat.

* If your PC has not been set up accordingly, start the "default.htm" file on the CD.

1.1 C3 ServoManagers

Installation of the C3 ServoManager

The Compax3 ServoManager can be installed directly from the Compax3 CD. Click on the appropriate hyperlink or start the installation program "C3Mgr Setup V.... .exe" and follow the instructions.

Minimum requirements

For successful installation, your PC must meet the following minimum requirements:

- ◆ Windows 98, Windows Me, Windows NT 4.0 (Intel) with Service Pack 6, Windows 2000 or Windows XP.
- ◆ Administrator authorization* on the system
- ◆ Microsoft Internet Explorer 4.01 (SP2) or higher
- ◆ Pentium-PC (300 MHz or faster is recommended)
- ◆ 64 MB RAM (128 MB recommended)
- ◆ Required HD capacity
 - ◆ CD-Installation: 350 MB before installation, 200 MB after installation
- ◆ Super VGA-Monitor (with a resolution of at least 800 x 600, setting: small fonts)

* you do not need administrator authorization for an update version!

Connection between PC and Compax3

Your PC is connected with Compax3 over an RS232 cable (SSK1) (COM 1/2 interface on the PC based on X10 Compax3).

Start the Compax3 ServoManager and make the setting for the selected interface in the menu Options: Port (RS232) COM 1 or COM 2.

Device selection

In the menu tree under device selection you can read the device type of the connected device (Online Device Identification) or select a device type (Device Selection Wizard).

Configuration

Then you can double click on "Configuration" to start the configuration wizard. The wizard will lead you through all input windows of the configuration.

Contents

| | |
|---|-----------|
| 1. Notes on the Documents Supplied | 3 |
| 1.1 C3 ServoManagers..... | 4 |
| 2. Introduction | 7 |
| 2.1 Device assignment | 7 |
| 2.2 Type specification plate | 8 |
| 2.3 Release 1/2004 | 9 |
| 2.3.1. New Compax3 functions | 9 |
| 2.3.1.1 Direct drives | 9 |
| 2.3.1.2 Switching frequency of the power output stage can be set | 9 |
| 2.3.1.3 Optimization of the predefined external setpoint via the analog input | 9 |
| 2.3.1.4 UL - certification | 9 |
| 2.3.1.5 New machine zero modes | 10 |
| 2.3.1.6 RS485 / RS232 - interface | 10 |
| 2.3.2. New functions of the Compax3 - Software - tools..... | 10 |
| 2.3.2.1 C3 ServoManager: configuring Compax3 , setup and optimization | 10 |
| 2.3.2.2 C3 MotorManager: configuration of almost any motor | 11 |
| 2.3.2.3 C3 IEC61131-3 - Debugger | 11 |
| 2.3.2.4 CoDeSys - IEC61131-3 – development tool..... | 11 |
| 2.3.2.5 CamEditor: cam creation for C3 T40 | 11 |
| 2.3.3. Complements/corrections in manual and online help..... | 11 |
| 2.4 Safety Instructions..... | 12 |
| 2.4.1. General hazards | 12 |
| 2.4.2. Safety-conscious working | 12 |
| 2.4.3. Special safety instructions | 13 |
| 2.5 Warranty conditions | 13 |
| 2.6 Conditions of utilization | 14 |
| 2.6.1. Conditions of utilization for CE-conform operation..... | 14 |
| 2.6.2. Conditions of utilization for UL certification..... | 16 |
| 2.7 Manufacturer's Declaration of Conformity..... | 17 |
| 3. Compax3 device description | 18 |
| 3.1 State of delivery | 18 |
| 3.2 Plug and connector assignment Compax3..... | 19 |
| 3.2.1. Function of the LEDs on the front panel | 20 |
| 3.2.2. Power supply plug X1 for 230VAC devices..... | 20 |
| 3.2.3. Power supply plug X1 for 400 VAC devices..... | 21 |

New Compax3 functions

| | | |
|------------|---|-----------|
| 3.2.4. | Ballast resistor / high voltage supply plug X2 for 230VAC devices | 21 |
| 3.2.5. | Ballast resistor / high voltage supply plug X2 for 400VAC devices | 22 |
| 3.2.6. | Motor / Motor brake (plug X3)..... | 23 |
| 3.2.7. | Control voltage 24VDC / enable (plug X4)..... | 24 |
| 3.2.8. | RS232 / RS485 interface (plug X10) | 25 |
| 3.2.9. | Analog / Encoder (plug X11)..... | 26 |
| 3.2.9.1 | Wiring of analog outputs | 26 |
| 3.2.9.2 | Wiring of the analog input | 27 |
| 3.2.10. | Digital inputs/outputs (plug X12) | 27 |
| 3.2.10.1 | Output wiring of digital outputs..... | 28 |
| 3.2.10.2 | Input wiring of digital inputs..... | 28 |
| 3.2.11. | Resolver / Feedback (connector X13)..... | 29 |
| 3.3 | Installation and dimensions Compax3..... | 30 |
| 3.3.1. | Installation and dimensions of Compax3 S0xx V2..... | 30 |
| 3.3.2. | Installation and dimensions of Compax3 S038 and S075 V4..... | 31 |
| 3.3.3. | Installation and dimensions of Compax3 S150 V4..... | 32 |
| 3.3.4. | Installation and dimensions of Compax3 S300 V4..... | 33 |
| 3.4 | Safety function – safe standstill - | 34 |
| 3.4.1. | Safety instructions for the “safe standstill” function | 36 |
| 3.4.2. | Application examples for “safe standstill” | 37 |
| 3.4.2.1 | Sample circuit example of Compax3 devices without fieldbus option | 37 |
| 3.4.2.2 | Sample circuit example of Compax3 devices with fieldbus option | 43 |
| 3.4.2.3 | Sample circuit for C3 powerPLmC multi-axis application | 46 |
| 4. | Technical Data..... | 51 |
| 5. | Index..... | 57 |

2. Introduction

You can read about the following in this chapter:

| | |
|--|----|
| Device assignment | 7 |
| Type plate | 8 |
| Release 1/2004 | 9 |
| Safety instructions | 12 |
| Warranty conditions | 13 |
| Conditions of utilization | 14 |
| Manufacturer's declaration of conformity | 17 |

2.1 Device assignment

This manual applies to the following devices:

- ◆ Compax3 S025 V2 + supplement
- ◆ Compax3 S063 V2 + supplement
- ◆ Compax3 S038 V4 + supplement
- ◆ Compax3 S075 V4 + supplement
- ◆ Compax3 S150 V4 + supplement
- ◆ Compax3 S300 V4 + supplement

2.2 Type specification plate

You will find the exact description of the device on the type specification plate, which is located on the right side of the device:

Compax3 - Type specification plate:

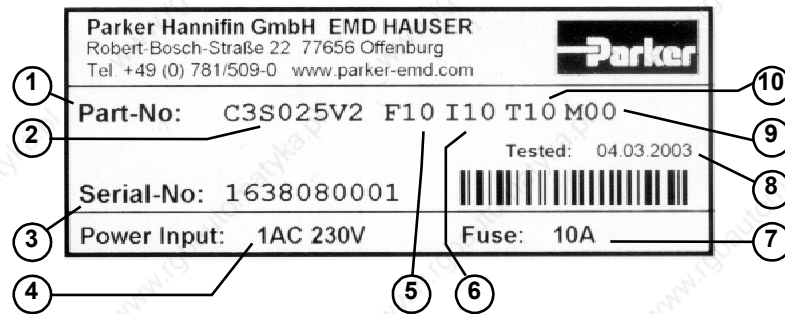

Explanation:

| | |
|----|--|
| 1 | Type designation The complete order designation of the device (2, 5, 6, 10, 9) |
| 2 | C3S025V2 C3: Abbreviation for Compax3 S: Single axis device with direct AC mains power supply 025: Device current drain in 100mA (025=2.5A) V2: 230VAC (single phase); V4: 400VAC (three phase) |
| 3 | Unique number of the particular device |
| 4 | Nominal power supply voltage of the device |
| 5 | Designation of the feedback system F10: Resolver F11: SinCos© / Single- or Multiturn F12: Feedback module for direct drives |
| 6 | Device interface I10: Analog, Step/Direction and Encoder Input I11: Digital inputs/outputs I20: Profibus DP I21: CANopen |
| 7 | Corresponding fuse protection |
| 8 | Date of factory test |
| 9 | Options |
| 10 | Technology function T10: Servo Controller T11: Positioning T30: Motion control programmable according to IEC61131-3 T40: Electronic cam control |

2.3 Release 1/2004

You can read about the following in this chapter:

| | |
|---|----|
| New Compax3 functions..... | 9 |
| New functions of the Compax3 software tools | 10 |
| Complements / corrections in manual and online help | 11 |

2.3.1. New Compax3 functions

You can read about the following in this chapter:

| | |
|--|----|
| Direct drives | 9 |
| Switching frequency of the power output stage can be set..... | 9 |
| Optimization of the predefined external setpoint via the analog input..... | 9 |
| UL certification..... | 9 |
| New machine zero modes | 10 |
| RS485 / RS232 interface | 10 |

2.3.1.1 Direct drives

The feedback module F12 supports the following feedback systems:

- ◆ Distance coding with 1VSS - Interface
- ◆ Distance coding with RS422 - Interface (Encoder)

2.3.1.2 Switching frequency of the power output stage can be set

The switching frequency of the power output stage can be increased if necessary. This helps mainly to reduce motor sounds.

Please note that power output stage losses increase with rising switching frequency. Therefore the nominal device currents must be reduced.

2.3.1.3 Optimization of the predefined external setpoint via the analog input

Given an external discrete signal read in via the analog input (possible with I10 T10 and T40), signal steps can only be avoided by averaging.

2.3.1.4 UL - certification

Compax3 now with **UL certification**. (see on page 16)

2.3.1.5 New machine zero modes

- ◆ Several new machine zero modes with limit switch: MN-Mode 1,2 7-10, 11-14, 17,18, 23-26, 27-30
- ◆ New machine zero modes in connection with the feedback module F12 F12 (direct drives) and distance coded feedback system: MN-Mode 130 - 133
- ◆ Limit switch can be configured

2.3.1.6 RS485 / RS232 - interface

Compax3 objects can be read and written in via RS232 and RS485.

2.3.2. New functions of the Compax3 - Software - tools

You can read about the following in this chapter:

| | |
|--|----|
| C3 ServoManager: configuring Compax3, setup and optimization | 10 |
| C3 MotorManager: configuration of almost any motors | 11 |
| C3 IEC61131-3 - Debugger | 11 |
| CoDeSys - IEC61131-3 – development tool | 11 |
| CamEditor: Cam creation for C3 T40 | 11 |

2.3.2.1 C3 ServoManager: configuring Compax3 , setup and optimization

A modified recipe array can be loaded separately (without complete download) into the device.

Firmware - Download

The Compax3 firmware can only be modified resp. updated with the aid of the C3 ServoManager.

For this you will need a so-called “firmware-package” (File: *.fwp).

Setup - support

You can set up all Compax3 technology functions easily in the optimization window.

2.3.2.2 C3 MotorManager: configuration of almost any motor

New:

- ◆ Integration of distance coded feedback systems
- ◆ Export / Import of user defined (customer's) motor
- ◆ Calibration of commutation also for linear motors with small travel path

Changes

- ◆ Linear motors with brakes can be configured
- ◆ Calculation of the recommended number of poles was corrected
- ◆ Calibration of SinCos motors was corrected
- ◆ The minimum moment of inertia was reduced from 10kgmm² to 1kgmm²
- ◆ Configuration of rotatory motors with analog hall sensors was completed

2.3.2.3 C3 IEC61131-3 - Debugger

Forcing of the inputs for T30 and T40 is possible.

2.3.2.4 CoDeSys - IEC61131-3 – development tool

New CoDeSys version 2.3.2.6

2.3.2.5 CamEditor: cam creation for C3 T40

-

2.3.3. Complements/corrections in manual and online help

New structure of the manual:

- ◆ All technology functions are described in a help.
- ◆ Manuals (PDF files) have a new structure:
 - ◆ I10 T10 manual
 - ◆ I11 T11 manual
 - ◆ I20 T11 manual
 - ◆ I21 T11 manual
- ◆ A single manual for all devices programmable according to IEC (I11 T30, I20 T30, I21 T30, I11 T40, I20 T40, I21 T40)
The assignment of the respective chapters is indicated.

2.4 Safety Instructions

You can read about the following in this chapter:

| | |
|-----------------------------------|----|
| General hazards | 12 |
| Working safely | 12 |
| Special safety instructions | 13 |

2.4.1. General hazards

General Hazards on Non-Compliance with the Safety Instructions

The device described in this manual is designed in accordance with the latest technology and is safe in operation. Nevertheless, the device can entail certain hazards if used improperly or for purposes other than those explicitly intended.

Electronic, moving and rotating components can

- ◆ constitute a hazard for body and life of the user, and
- ◆ cause material damage

Usage in accordance with intended purpose

The device is designed for operation in electric power drive systems (VDE0160). Motion sequences can be automated with this device. Several motion sequences can be combined by interconnecting several of these devices. Mutual interlocking functions must be incorporated for this purpose.

2.4.2. Safety-conscious working

This device may be operated only by qualified personnel.

Qualified personnel in the sense of these operating instructions consists of:

- ◆ Persons who, by virtue to their training, experience and instruction, and their knowledge of pertinent norms, specifications, accident prevention regulations and operational relationships, have been authorized by the officer responsible for the safety of the system to perform the required task and in the process are capable of recognizing potential hazards and avoiding them (definition of technical personnel according to VDE105 or IEC364),
- ◆ Persons who have a knowledge of first-aid techniques and the local emergency rescue services.
- ◆ Persons who have read and will observe the safety instructions.
- ◆ Those who have read and observe the manual or help (or the sections pertinent to the work to be carried out).

This applies to all work relating to setting up, commissioning, configuring, programming, modifying the conditions of utilization and operating modes, and to maintenance work.

This manual and the help information must be available close to the device during the performance of all tasks.

2.4.3. Special safety instructions

- ◆ Check the correct association of the device and its documentation.
- ◆ Never detach electrical connections while voltage is applied to them.
- ◆ Safety devices must be provided to prevent human contact with moving or rotating parts.
- ◆ Make sure that the device is operated only when it is in perfect condition.
- ◆ Implement and activate the stipulated safety functions and devices.
- ◆ Operate the device only with the housing closed.
- ◆ Ensure that motors and any linear drives present are mounted securely.
- ◆ Check that all live terminals are secured against contact. Fatal voltage levels of to 750V occur.

2.5 Warranty conditions

- ◆ The device must not be opened.
- ◆ Do not make any modifications to the device, except for those described in the manual.
- ◆ Make connections to the inputs, outputs and interfaces only in the manner described in the manual.
- ◆ When installing the device, make sure the heat dissipater receives sufficient air.
- ◆ Attach the devices according to the mounting instructions, using the provided fixing holes. We cannot provide any guarantee for any other mounting methods.

Note on exchange of options

Compax3 options must be exchanged in the factory to ensure hardware and software compatibility.

2.6 Conditions of utilization

2.6.1. Conditions of utilization for CE-conform operation

- Industry and trade -

The EC guidelines for electromagnetic compatibility 89/336/EEC and for electrical operating devices for utilization within certain voltage limits 73/23/EEC are fulfilled when the following boundary conditions are observed:

Operation of the devices only in the condition in which they were delivered, i.e. with all housing panels.

Mains filter: A mains filter is required in the mains input line if the motor cable exceeds a certain length. Filtering can be provided centrally at the plant mains input or separately at the mains input to each device.

Commercial and residential area (limit values of Class A in accordance with EN 61800-3)

The following mains filters are available for independent utilization:

| Device: Compax3 | Order No.: | Condition: |
|----------------------|------------|--------------------------------------|
| S0xx V2: | NFI01/01 | Only for motor lines longer than 10m |
| S038, S075, S150 V4: | NFI01/02 | Only for motor lines longer than 10m |
| S300 | NFI01/03 | Only for motor lines longer than 10m |

Industrial area (limit values in accordance with EN 61800-3)

Longer motor cable lengths are possible in industrial areas without a mains power filter.

Connection length: connection between mains filter and device:

unscreened: < 0,5m
shielded: < 5m (fully shielded on ground – e.g. ground of control cabinet)

Motor and resolver cable:

Operation of the devices only with Parker motor and resolver cables (their plugs contain a special full surface area screening).

The following cable lengths are permitted:

Motor cable < 100 m (the cable should not be rolled up!)
A motor output filter is required for motor cables >20 m.

- ◆ MDR01/04 (max. 6.3A rated motor current)
- ◆ MDR01/01 (max. 16A rated motor current)
- ◆ MDR01/02 (max. 30A rated motor current)

Screening connection of the motor cable

The motor cable should be fully screened and connected to the Compax3 housing. We offer a special shield connecting terminal as accessory item.

Resolver cable < 100 m

Motors: Operation with standard motors.

Control: Use only with aligned controller (to avoid control loop oscillation).

Grounding: Connect the filter housing and the Compax3 (grounding screw on the underside) to the cabinet frame, making sure that the contact area is adequate and that the connection has low resistance and low inductance.

Never mount the filter housing and the device on paint-coated surfaces!

Cable installation: Signal lines and power lines should be installed as far apart as possible. Signal leads should never pass close to excessive sources of interference (motors, transformers etc.).

Accessories: Make sure to use only the accessories recommended by Parker

Connect all cable shields at both ends, ensuring large contact areas!

Warning:

This is a product in the restricted sales distribution class according to EN 61800-3. In a domestic area this product can cause radio frequency disturbance, in which case the user may be required to implement appropriate remedial measures.

2.6.2. Conditions of utilization for UL certification

UL certification

| | |
|-----------------------|------------------------|
| conform to UL: | ◆ according to UL508C |
| Certified | ◆ E-File_No.: E235 342 |

The UL certification is documented by a UL logo on the device (type specification plate)

"UL" - logo:



Conditions of utilization

- ◆ The devices are only to be installed in a degree of contamination 2 environment (maximum).
- ◆ The devices must be appropriately protected (e.g. by a switching cabinet).
- ◆ The terminals are suitable for field wiring.
- ◆ Tightening torque of the field wiring terminals (green Phoenix plugs)

| | | |
|----------------------------|-------------|--------------|
| ◆ C3SxxxV2 | 0.57-0.79Nm | 5 - 7Lb.in |
| ◆ C3SxxxV4 exsept C3S300V4 | 0.57-0.79Nm | 5 - 7Lb.in |
| ◆ C3S300V4 | 1.25-1.7Nm | 11 - 15Lb.in |
- ◆ Temperature rating of field installed conductors shall be at least 60°C Use copper conductors only. Please use the cables described in the accessories chapter; they do have a temperature rating of at least 60°C
- ◆ Maximum ambient temperature: 45°C.
- ◆ Suitable for use on a circuit capable of delivering not more than 500 rms symmetrical amperes, 400 volts maximum.



ATTENTION

Danger of electric shock.

Discharge time of the bus capacitor is 5 minutes.

- ◆ The drive provides internal motor overload protection.
This must be set so that 200% of the nominal motor current are not exceeded.
- ◆ Cable cross-sections
- ◆ Mains input: corresponding to the recommended **fuses** (see on page 51)
- ◆ Motor cables: corresponding to the **nominal output currents** (see on page 51)
- ◆ Maximum cross-section limited by the terminals mm² / AWG

| | | |
|----------------------------|--------------------|--------|
| ◆ C3SxxxV2 | 2.5mm ² | AWG 12 |
| ◆ C3SxxxV4 exsept C3S300V4 | 4.0mm ² | AWG 10 |
| ◆ C3S300V4 | 6.0mm ² | AWG 7 |
- ◆ Circuit protection
In addition to the branch circuit protection, the devices have to be protected with the supplementary protector S 261 L, manufactured by ABB.
- ◆ C3S025V2: ABB, nominal 400V 10A, 6kA
- ◆ C3S063V2: ABB, nominal 400V, 16A, 6kA
- ◆ C3S038V4: ABB, nominal 400V, 10A, 6kA
- ◆ C3S075V4: ABB, nominal 400V, 16A, 6kA
- ◆ C3S150V4: ABB, nominal 400V, 20A, 6kA
- ◆ C3S300V4: ABB, nominal 400V, 25A, 6kA
- ◆ C3S300V4: ABB, nominal 400V, 25A, 6kA

2.7 Manufacturer's Declaration of Conformity

As defined by the EC Electromagnetic Compatibility (EMC) Directive 89/336/EEC and

the EC Directive relating to electrical equipment designed for use within certain voltage limits (Low Voltage Directive) 73/23/EEC

We (the manufacturer)

Parker Hannifin GmbH

hereby declare that the product(s) listed below:

Device type: intelligent servo drives

Model: Compax3

to which this declaration relates, including the product model placed on the market by us, have been designed and manufactured in conformity with the essential requirements of the Standards and other Normative Documents listed in the following.

Applied harmonized Standards, especially:

Electromagnetic Compatibility

EN 61 800-3

VDE 0160 part 100

EMC product standard for adjustable speed electrical power drive systems including special testing procedures

Safety

EN 50 178/

VDE 0160

Electronic equipment for use in power installations.

Caution!

The present Manufacturer's Declaration of Conformity is valid only if the master conditions for operation described in the "Conditions of Use" section have been met.

In the case of non-conformity with these conditions or upon modification of the product, the present declaration will become invalid.

3. Compax3 device description

You can read about the following in this chapter:

| | |
|--|----|
| State of delivery..... | 18 |
| Plug and connector assignment Compax3..... | 19 |
| Installation and dimensions Compax3..... | 30 |
| Safety function – safe standstill | 34 |

3.1 State of delivery

Compax3 is delivered without configuration!

After switching on the 25VDC supply, the red LED is flashing while the green LED is dark.

Please configure the device with the help of the Windows-Software “Compax3 – ServoManager”!

3.2 Plug and connector assignment Compax3

You can read about the following in this chapter:

| | |
|--|----|
| Function of the LEDs on the front panel..... | 20 |
| Power supply plug X1 for 230VAC devices..... | 20 |
| Power supply plug X1 for 400VAC devices..... | 21 |
| Ballast resistor / High voltage supply plug X2 for 230VAC devices..... | 21 |
| Ballast resistor / High voltage supply plug X2 for 400VAC devices..... | 22 |
| Motor / Motor brake (plug X3)..... | 23 |
| Control voltage 24 VDC / enable (plug X4)..... | 24 |
| RS 232 / RS485 interface (plug X10)..... | 25 |
| Analog / Encoder (plug X11)..... | 26 |
| Digital inputs /outputs (plug X12)..... | 27 |
| Resolver / Feedback (plug X13)..... | 29 |

Connection assignment based on the example of Compax3 S025 V2:

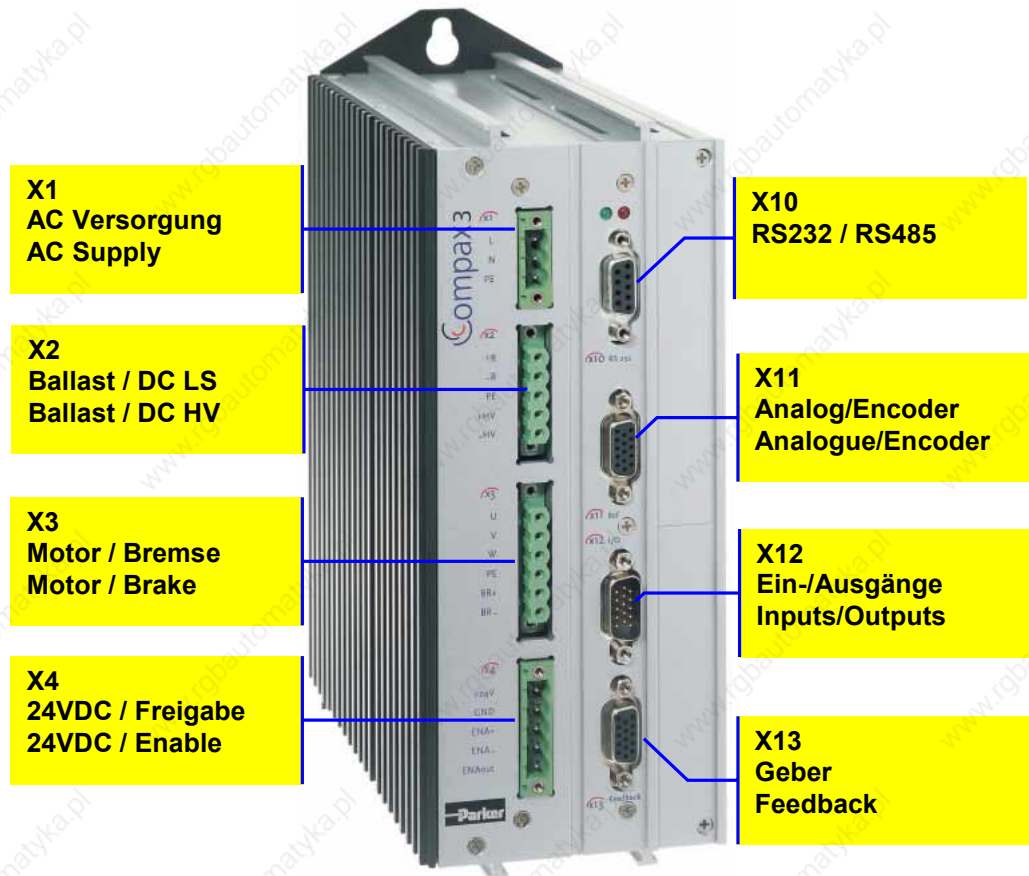

Always switch devices off before wiring them!

Dangerous voltages are still present until 5 minutes after switching off the power supply!

Function of the LEDs on the front panel

Caution!

When the control voltage is missing there is no indication whether or not high voltage supply is available.

3.2.1. Function of the LEDs on the front panel

| State | LED red | LED green |
|---|----------------------|-----------------|
| Voltages missing | off | off |
| While booting | alternately flashing | |
| <ul style="list-style-type: none"> ◆ No configuration present. ◆ SinCos feedback not detected. ◆ IEC program not compatible with the firmware. ◆ For F12: Hall signals invalid. | flashing | off |
| Axis without current excitation | off | Flashes slowly |
| Power supplied to axis; commutation calibration running | off | Flashes quickly |
| Axis with current excitation | off | on |
| Axis in fault status / fault present | on | off |

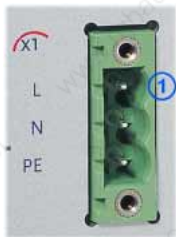
3.2.2. Power supply plug X1 for 230VAC devices

| PIN | Description |
|-----|-------------|
| 1 | L |
| 2 | N |
| 3 | PE |

Mains connection: Compax3 S0xx V2

| Controller type | S025 V2 | S063 V2 |
|--------------------------------|--|------------------------------------|
| Mains voltage | Single phase 230VAC + 10% 80-230VAC+10% / 50-60Hz | |
| Rated input current | 6Aeff | 16Aeff |
| Maximum fuse rating per device | 10A (automatic circuit breaker K) | 16 A (automatic circuit breaker K) |



Always switch devices off before wiring them!

Dangerous voltages are still present until 5 minutes after switching off the power supply!

3.2.3. Power supply plug X1 for 400 VAC devices

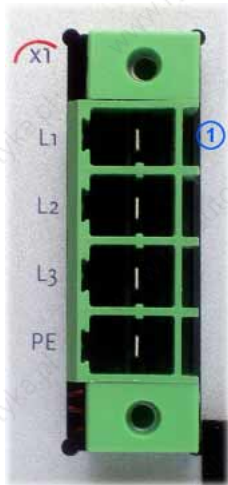

| PIN | Description |
|-----|-------------|
| 1 | L1 |
| 2 | L2 |
| 3 | L3 |
| 4 | PE |

Mains connection Compax3 Sxxx V4

| Controller type | S038 V4 | S075 V4 | S150 V4 | S300 V4 |
|--------------------------------|---|------------------------------------|---------|-----------------------------------|
| Mains voltage | Three-phase 3*400VAC 80-480 VAC+10% / 50-60 Hz | | | |
| Rated input current | 6Aeff | 10 Aeff | 16Aeff | 22Aeff |
| Maximum fuse rating per device | 10A (automatic circuit breaker K) | 16 A (automatic circuit breaker K) | | 25A (automatic circuit breaker K) |



Always switch devices off before wiring them!

Dangerous voltages are still present until 5 minutes after switching off the power supply!

3.2.4. Ballast resistor / high voltage supply plug X2 for 230VAC devices

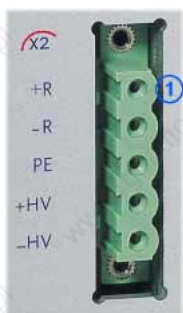

| PIN | Description |
|-----|--------------------------|
| 1 | + Ballast resistor |
| 2 | - Ballast resistor |
| 3 | PE |
| 4 | + DC high voltage supply |
| 5 | - DC high voltage supply |



Caution! The connector assignment of X2 is changed!

Please note the screen printing on the front plate of the device: this is valid

Brake operation Compax3 Sxxx V2

| Controller type | S025 V2 | S063 V2 |
|----------------------------------|--------------------|---------------------|
| Capacitance / storable energy | 560 μ F / 15Ws | 1120 μ F / 30Ws |
| Minimum ballast - resistance | 100 Ω | 56 Ω |
| Recommended nominal power rating | 20 ... 60W | 60 ... 180W |
| Pulse power rating for 1s | 1kW | 2.5kW |

Caution!

The power voltage DC of two Compax3 V2 devices (230V devices) must not be connected.

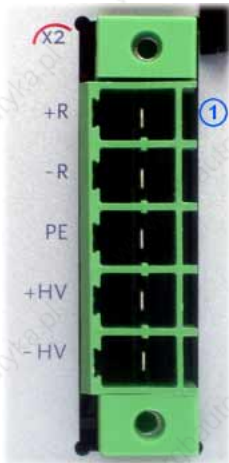
3.2.5. Ballast resistor / high voltage supply plug X2 for 400VAC devices

| PIN | Description |
|-----|--------------------------|
| 1 | + Ballast resistor |
| 2 | - Ballast resistor |
| 3 | PE |
| 4 | + DC high voltage supply |
| 5 | - DC high voltage supply |



Caution! The connector assignment of X2 is changed!

Please note the screen printing on the front plate of the device: this is valid

Compax3 Sxxx V4 brake operation

| Controller type | S038 V4 | S075 V4 | S150 V4 | S300 V4 |
|----------------------------------|--------------------|--------------------|---------------------|----------------------|
| Capacitance / storable energy | 235 μ F / 37Ws | 470 μ F / 75Ws | 690 μ F / 110Ws | 1100 μ F / 176Ws |
| Minimum ballast - resistance | 100 Ω | 56 Ω | 22 Ω | 15 Ω |
| Recommended nominal power rating | 60 ... 250W | 60 ... 500 W | 60 ... 1000 W | 60 ... 1000 W |
| Pulse power rating for 1s | 2.5kW | 5kW | 10 kW | 42kW |

Connection of the power voltage of 2 Compax3 V4 devices (400V devices)

In order to improve the conditions during brake operation, the DC power voltage of 2 devices may be connected.

The capacity as well as the storable energy are increased; furthermore the braking energy of one device may be utilized by a second device, depending on the application.

Please connect as follows:

Device 1 X2/4 to device 2 X2/4

Device 1 X2/5 to device 2 X2/5

Please note the following:

Caution! In case of non-compliance with the following instructions, the device may be destroyed!

- ◆ You can only connect two similar devices (same power supply; same rated currents)
- ◆ Connected devices must always be fed separately via the AC power supply.

3.2.6. Motor / Motor brake (plug X3)



| PIN | Description | |
|-----|-------------|---------------------|
| 1 | U (motor) | |
| 2 | V (motor) | |
| 3 | W (motor) | |
| 4 | PE (motor) | |
| 5 | BR+ | Motor holding brake |
| 6 | BR- | Motor holding brake |

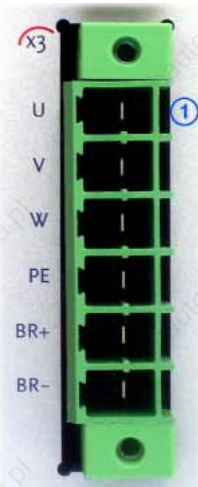

Screening connection of the motor cable

The motor cable should be fully screened and connected to the Compax3 housing. We offer a special shield connecting terminal as accessory item.



Connect the brake only on motors which have a holding brake! Otherwise make no brake connections at all.

Motor holding brake output

| | |
|--|------------|
| Controller type | Compax3 |
| Voltage range | 21 – 27VDC |
| Maximum output current (short circuit proof) | 1.6 A |

3.2.7. Control voltage 24VDC / enable (plug X4)



| PIN | Description |
|-----|--------------|
| 1 | +24 V |
| 2 | Gnd24 V |
| 3 | Enable_in |
| 4 | Enable_out_a |
| 5 | Enable_out_b |

Control voltage 24 VDC

| | |
|--|---|
| Controller type | Compax3 |
| Voltage range | 21 - 27VDC |
| Current drain of the device | 0.8 A |
| Total current drain | 0.8 A + Total load of the digital outputs + current for the motor holding brake |
| Ripple | 0.5Vpp |
| Requirement according to safe extra low voltage (SELV) | yes |

Power stage enable: X4/3=24 VDC

Tolerance range: 18.0 V – 33.6 V / 720 Ω

The +24V supply can be taken, for example, from Pin 1.

Safe standstill (X4/3=0V)

For implementation of the "Safe standstill" safety feature in accordance with the "protection against unexpected start-up" described in EN1037. Please refer to the respective **chapter** (see on page 34) (can be found in the paper version "installation manual Compax3) with the circuitry examples!

The energy supply to the drive is reliably shut off, the motor has no torque.

A relay contact is located between X4/4 and X4/5 (normally closed contact)

| Enable_out_a - Enable_out_b | Power output stage is |
|-----------------------------|-----------------------|
| Contact opened | activated |
| Contact closed | deactivated |

Series connection of these contacts permits certain determination of whether all drives are de-energized.

Relay contact data:

Switching voltage (AC/DC): 100 mV – 60 V

Switching current: 10 mA – 0.3 A

3.2.8. RS232 / RS485 interface (plug X10)



Interface selectable by contact functions assignment of X10/1:

X10/1=0V RS232

X10/1=5V RS485

RS232

| PIN X10 | RS232 (Sub D) |
|---------|-------------------|
| 1 | (Enable RS232) 0V |
| 2 | RxD |
| 3 | TxD |
| 4 | DTR |
| 5 | GND |
| 6 | DSR |
| 7 | RTS |
| 8 | CTS |
| 9 | +5V |

RS485 2-wire

| PIN X10 | RS485 two wire (Sub D) Pin 1 and 9 jumpered externally |
|---------|---|
| 1 | Enable RS485 (+5V) |
| 2 | res. |
| 3 | TxD_RxD/ |
| 4 | res. |
| 5 | GND |
| 6 | res. |
| 7 | TxD_RxD |
| 8 | res. |
| 9 | +5V |

RS485 4-wire

| PIN X10 | RS485 four wire (Sub D) Pin 1 and 9 jumpered externally |
|---------|--|
| 1 | Enable RS485 (+5V) |
| 2 | RxD |
| 3 | TxD/ |
| 4 | res. |
| 5 | GND |
| 6 | res. |
| 7 | TxD |
| 8 | RxD/ |
| 9 | +5V |

3.2.9. Analog / Encoder (plug X11)



| PIN X11 | Reference | |
|---------------------------|---|-------------------------------------|
| High Density Sub D | | |
| 1 | +24V (output for encoder) max. 70mA | |
| 2 | Ain1 -: analogue input - (14-bit) | |
| 3 | D/A monitor channel 1 ($\pm 10V$, 8-bit resolution) | |
| 4 | D/A monitor channel 0 ($\pm 10V$, 8-bit resolution) | |
| 5 | +5V (output for encoder) max. 150mA | |
| 6 | - Input: steps RS422 (5V - level) | A/ (encoder input/emulation) |
| 7 | + Input: steps RS422 (5V - level) | A (encoder input/emulation) |
| 8 | + Input: direction RS422 (5V - level) | B (encoder input/emulation) |
| 9 | Ain0 +: analogue input + (14-bit) | |
| 10 | Ain1 +: analogue input + (14-bit) | |
| 11 | Ain0 -: analogue input - (14-bit) | |
| 12 | - Input: direction RS422 (5V - level) | B/ (encoder input/emulation) |
| 13 | Reserved | N/ (Encoder simulation) |
| 14 | Reserved | N (Encoder simulation) |
| 15 | GND | |

The exact assignment depends on the the device type!

You will find the description of the device-specific assignment in the online help which can be opened from the Compax3 – ServoManager.

3.2.9.1 Wiring of analog outputs

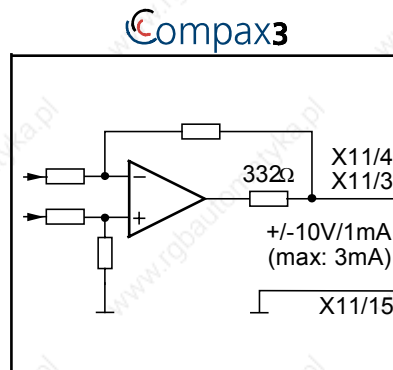

3.2.9.2 Wiring of the analog input

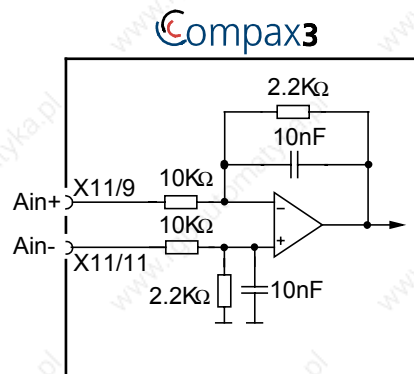

3.2.10. Digital inputs/outputs (plug X12)



| PIN X12/ | Input/output | I/O /X12 High density/Sub D |
|----------|--------------|---|
| 1 | O | +24VDC output (max. 400mA) |
| 2 | O0 | Output 0 (max. 100mA) |
| 3 | O1 | Output 1 (max. 100mA) |
| 4 | O2 | Output 2 (max. 100mA) |
| 5 | O3 | Output 3 (max. 100mA) |
| 6 | I0 | Input 0 |
| 7 | I1 | Input 1 |
| 8 | I2 | Input 2 |
| 9 | I3 | Input 3 |
| 10 | I4 | Input 4 |
| 11 | I | 24V input for the digital outputs Pins 2 to 5 |
| 12 | I5 | Input 5 |
| 13 | I6 | Input 6 |
| 14 | I7 | Input 7 |
| 15 | O | Gnd 24 V |

All inputs and outputs have 24V level.

Maximum capacitive load on the outputs: 50 nF (max. 4 Compax3 inputs)

The exact assignment depends on the the device type!

You will find the description of the device-specific assignment in the online help which can be opened from the Compax3 – ServoManager.

3.2.10.1 Output wiring of digital outputs

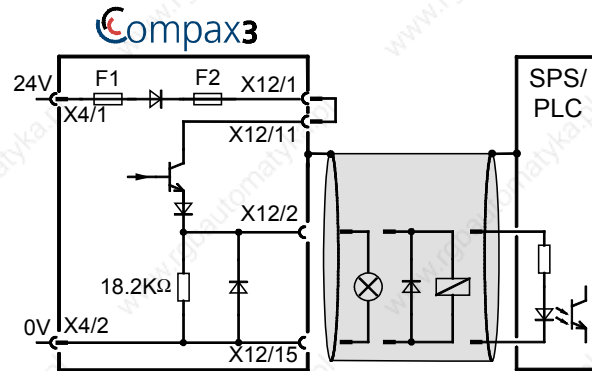

The circuit example is valid for all digital outputs!

The outputs are short circuit proof; a short circuit generates an error.

F1: Delayed action fuse

F2: Quick action electronic fuse; can be reset by switching the 24VDC supply off and on again.

3.2.10.2 Input wiring of digital inputs

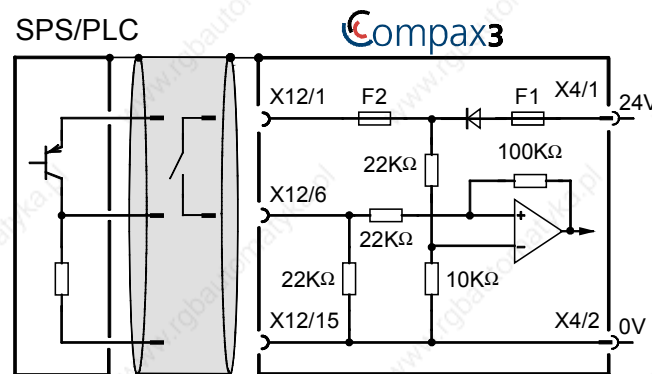

The circuit example is valid for all digital inputs!

F1: Delayed action fuse

F2: Quick action electronic fuse; can be reset by switching the 24VDC supply off and on again.

3.2.11. Resolver / Feedback (connector X13)



| PIN X13 | Feedback /X13 High Density /Sub D (dependent on the Feedback Module) | | |
|---------|---|--------------|--|
| | Resolver (F10) | SinCos (F11) | Direct drives (F12) |
| 1 | res. | res. | Sense - |
| 2 | res. | res. | Sense + |
| 3 | GND | GND | Hall1 |
| 4 | REFres+ | Vcc (+8V) | Vcc (+5V) (controlled on the encoder side) max. 200mA load |
| 5 | +5V (for temperature sensor) | | +5V (for temperature and hall sensors) |
| 6 | CLKfbk | CLKfbk | Hall2 |
| 7 | SIN- | SIN- | SIN- / A- (Encoder) |
| 8 | SIN+ | SIN+ | SIN+ / A+ (Encoder) |
| 9 | CLKfbk/ | CLKfbk/ | Hall3 |
| 10 | Tmot | Tmot | Tmot |
| 11 | COS- | COS- | COS- / B- (Encoder) |
| 12 | COS+ | COS+ | COS+ / B+ (Encoder) |
| 13 | res. | DATAfbk | N+ |
| 14 | res. | DATAfbk/ | N- |
| 15 | REFres- | GND (Vcc) | GND (Vcc) |

Note on F12:

+5V (Pin 4) is measured and controlled directly at the end of the line via Sense – and Sense +.

Maximum length of cable: 100m

Caution! Pin 4 and Pin 5 must under no circumstances be connected!

Resolver cable

SinCos cable

3.3 Installation and dimensions Compax3

You can read about the following in this chapter:

| | |
|--|----|
| Installation and dimensions Compax3 S0xx V2..... | 30 |
| Installation and dimensions Compax3 S038 and S075 V4 | 31 |
| Installation and dimensions Compax3 S150 V4 | 32 |
| Installation and dimensions Compax3 S300 V4 | 33 |

3.3.1. Installation and dimensions of Compax3 S0xx V2

Mounting:

3 socket head screws M5

Mounting spacing:

Device separation 15 mm

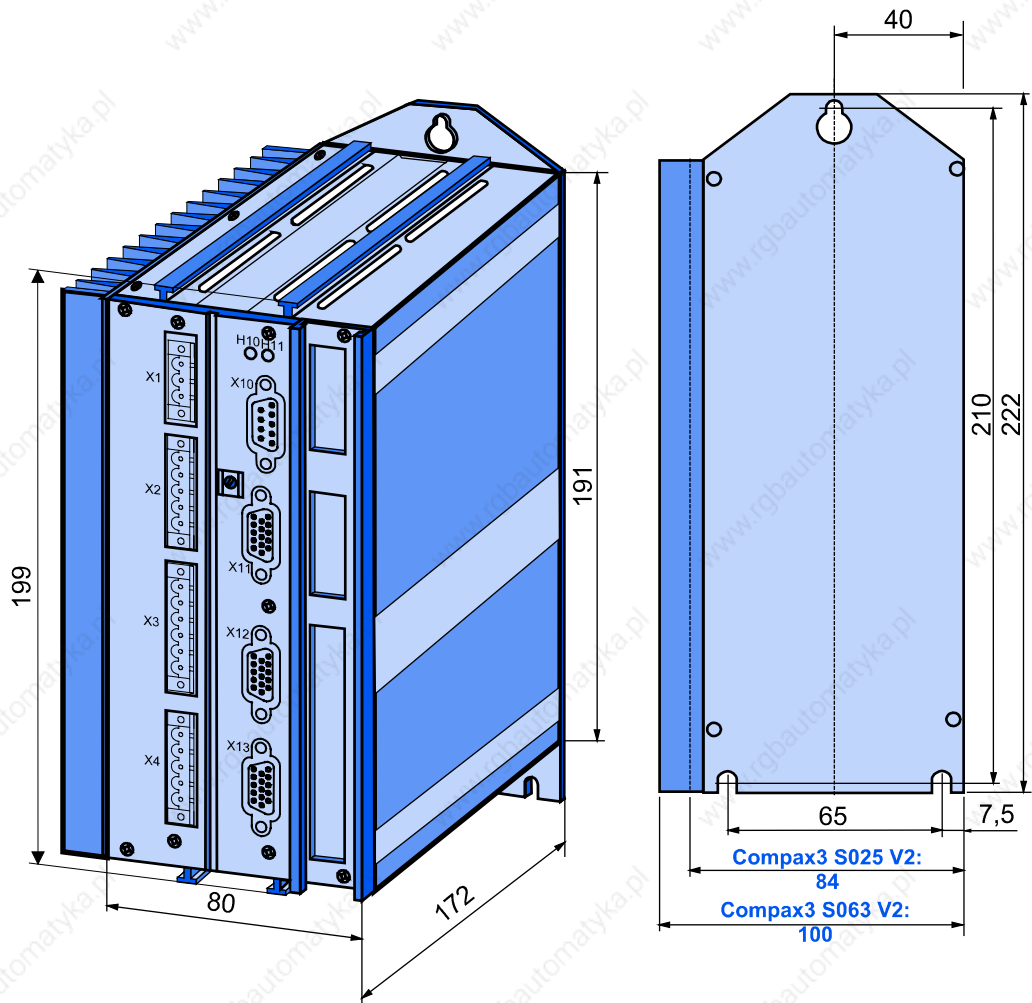

3.3.2. Installation and dimensions of Compax3 S038 and S075 V4

Mounting:

3 socket head screws M5

Mounting spacing:

Device separation 15 mm

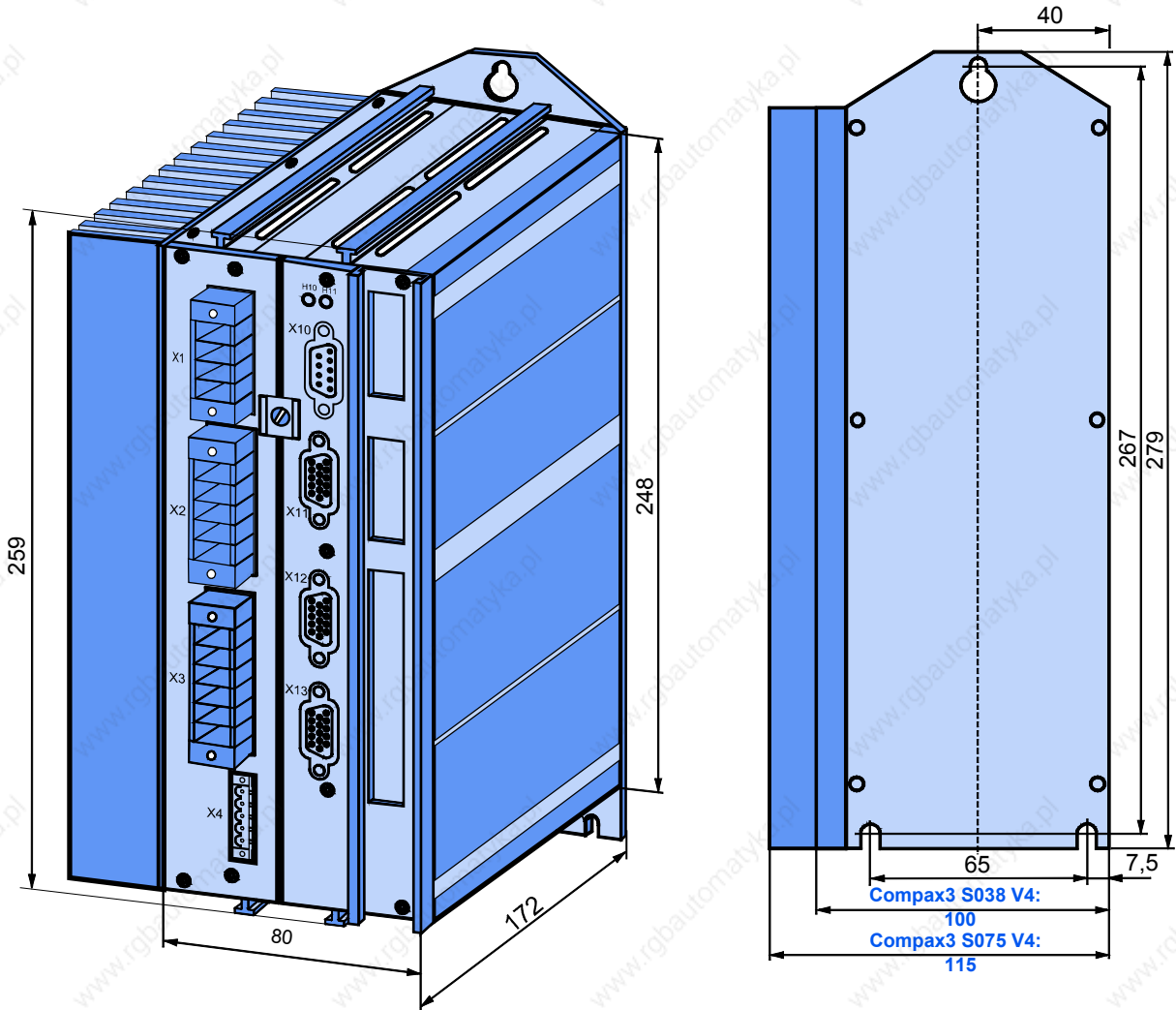

3.3.3. Installation and dimensions of Compax3 S150 V4

Mounting:

4 socket head screws M5

Mounting spacing:

Device separation 15 mm

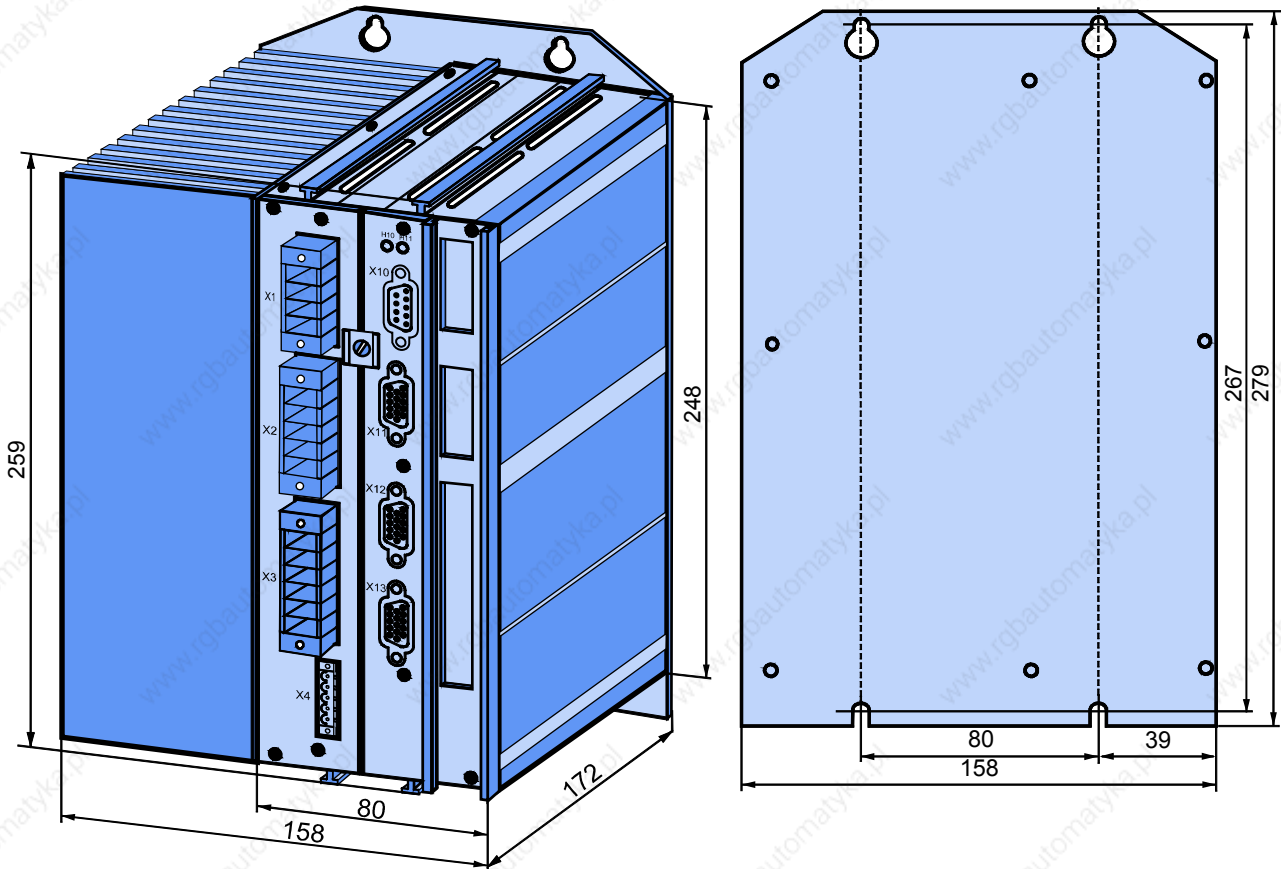

3.3.4. Installation and dimensions of Compax3 S300 V4**Mounting:**

4 socket head screws M5

Mounting spacing:

Device separation 15 mm

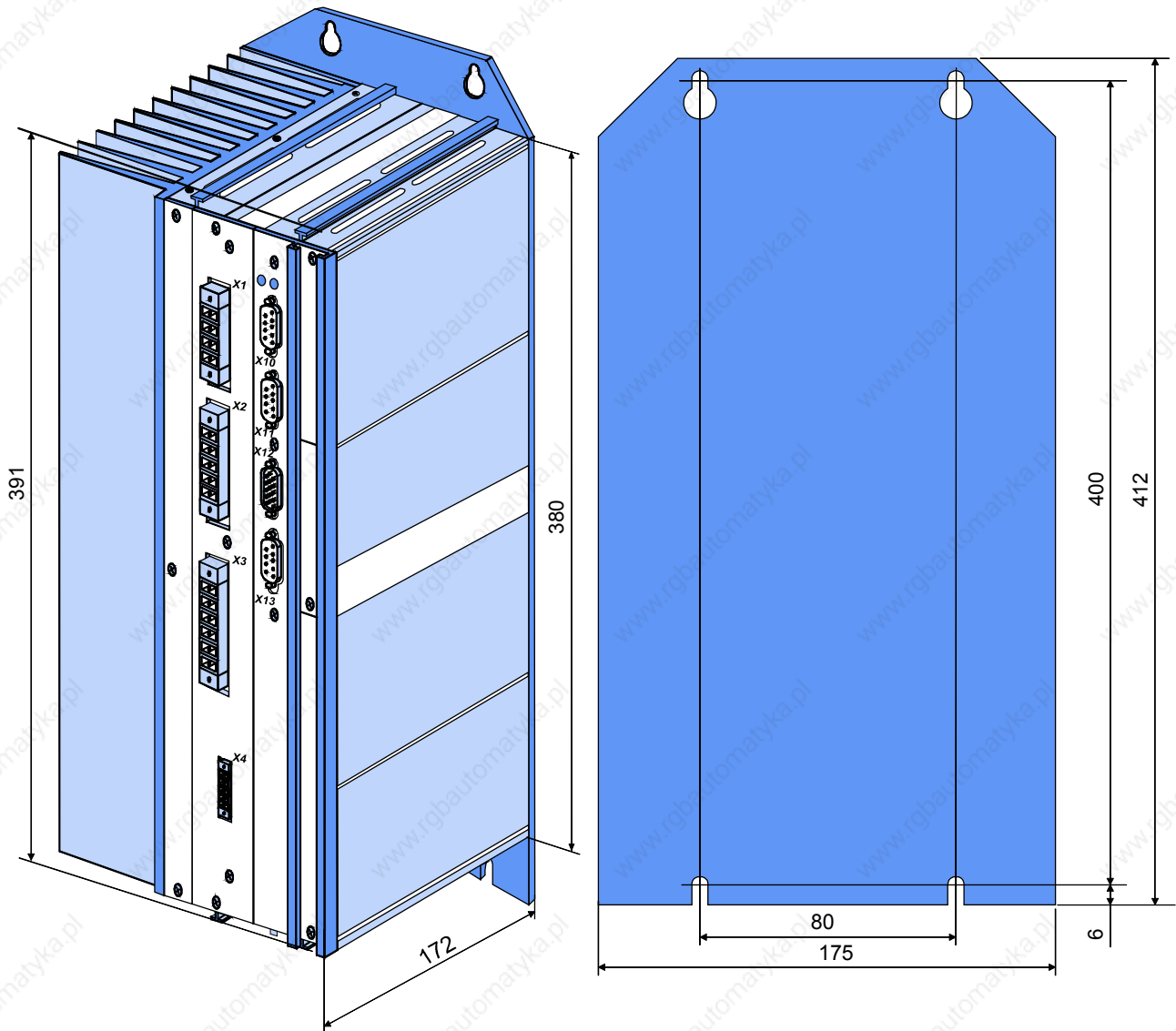

Compax3 S300 V4 is force-ventilated via a fan integrated into the heat dissipater!

3.4 Safety function – safe standstill -

You can read about the following in this chapter:

| | |
|---|----|
| Safety instructions concerning the function „Safe Standstill“ | 36 |
| Application examples „Safe Standstill“ | 37 |

Compax3 is equipped with the "Safe Standstill" safety feature.

The "protection against unexpected start-up" described in EN1037 can be implemented with this feature.

Principle:

To ensure safe protection against a motor starting up unexpectedly, the flow of current to the motor and thus to the power output stage must be prevented.

This is accomplished for Compax3 with two measures independent of each other (Channel 1 and 2), without disconnecting the drive from the power supply:

Channel 1:

Activation of the power output stage can be disabled in the Compax3 controller by means of a digital input or with a fieldbus interface (depending on the Compax3 device type) (deactivation of the energize input).

Channel 2:

The power supply for optocouplers and drivers of power output stage signals is disconnected by a safety relay activated by the "ENABLE" (X4/3) input and equipped with force-directed contacts. This prevents control signals from being transferred to the power output stage.

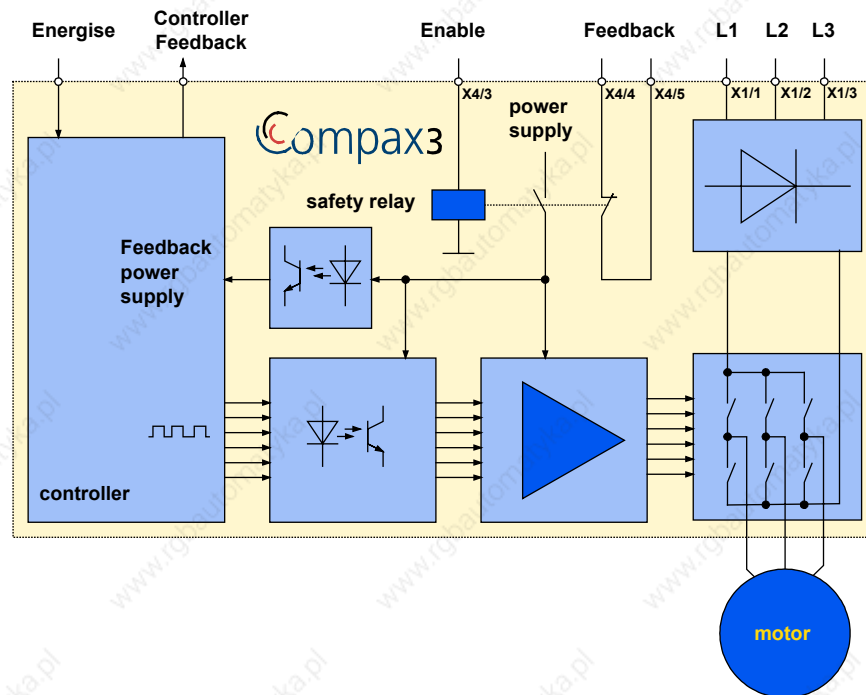

The „Safe Standstill“ safety function as defined by EN 954-1 Category 3 is only possible if both channels are used.

Circuit diagram illustrating working principle:**Notes**

- ◆ In normal operation of Compax3, 24 V DC of power is supplied to the "Enable" input (X4/3). The drive is then controlled by the inputs/outputs or the fieldbus.
- ◆ When used properly, the "Safe standstill" safety function is only used when the motor is at a standstill, since it is not capable of braking a motor or bringing it to a standstill by itself.

Compax3-specific inputs and outputs

The "Energize" input and the "Controller Feedback" output depend on the Compax3 device type:

- ◆ Compax3 I10 T10, I11 T11: a permanently assigned digital input and output (see in the application examples).
- ◆ Compax3 T30, T40: "Energize" and "Controller Feedback" are applied to the I/Os by way of the IEC program.
- ◆ Compax3 with Fieldbus: "Energize" and "Controller Feedback" are activated or queried by the fieldbus (via control and status word).

3.4.1. Safety instructions for the “safe standstill” function

- ◆ Safety functions must be tested 100%.
- ◆ Only qualified staff members are permitted to install the „Safe Standstill“ feature and place it in service.
- ◆ For all applications in which the first channel of the „Safe Standstill“ is implemented by means of a PLC, care must be taken that the part of the program that is responsible for current flowing to or not flowing to the drive is programmed with the greatest possible care. The „Safe Standstill“ application example of Compax3 with fieldbus should be considered.
The designer and operator responsible for the system and machine must refer programmers who are involved to these safety-related points.
- ◆ Terminal X4/2 (GND 24 V and at the same time the reference point for the safety relay bobbin) must be connected with the PE protective lead. This is the only way to ensure protection against incorrect operation through earth faults (EN60204-1 Section 9.4.3)!
- ◆ All conditions necessary for **CE-conform operation** (see on page 14 must be observed).
- ◆ It should be noted in connection with the „Safe Standstill“ application example illustrated here that after the Emergency Power-off switch has been activated, no galvanic isolation in accordance with EN 60204-1 Section 5.5 is guaranteed. This means that the entire system must be disconnected from the mains power supply with an additional main switch or mains power contactor for an “Emergency Power-off” (for example for repair jobs). Please note in this regard that even after the power is disconnected, dangerous electrical voltages may still be present in the Compax3 drive for about 5 minutes.
- ◆ When using an external Emergency Stop module with adjustable delay time, (as illustrated in the „Safe Standstill“ application example), it must be ensured that the delay time cannot be adjusted by persons not authorized to do so (for example by applying a lead seal).
The adjustable delay time on the Emergency Power-off module must be set to a value greater than the duration of the braking ramp controlled by the Compax3 with maximum load and maximum speed.
If the setting range for the specified Emergency power-off module is not sufficient, the Emergency power-off module must be replaced by another comparable module.
- ◆ All safety-related external leads (for example the control lead for the safety relay and feedback contact) must absolutely be laid so they are protected, for example in a cable duct. Short circuits and crossed wires must be reliably excluded!
- ◆ If there are external forces operating on the drive axes, additional measures are required (for example additional brakes). Please note in particular the effects of gravity on suspended loads!
- ◆ If the power fails, the possibility must be considered that for the application with stop category K1, such as is described in the application example, it will no longer be possible to execute the braking ramp controlled to speed 0.
- ◆ It is important to note that if the drive is being activated (Energize) by the RS232 (RS485) interface, it may not be possible to execute switch-off by a controlled braking ramp. For example, this is true when the set-up window of the C3 ServoManager is used. If set-up mode is turned on, the digital I/O interface and fieldbus interface are automatically disabled.

3.4.2. Application examples for “safe standstill”

You can read about the following in this chapter:

| | |
|---|----|
| Circuit example for Compax3 – devices without bus option..... | 37 |
| Circuit example for Compax3 devices with bus option | 43 |
| Circuit example for C3 powerPLmC – multi-axis application | 46 |

The application examples described here correspond to Stop Category 1 as defined by EN60204-1.

A Stop Category 0 in accordance with EN 60204-1 can be implemented, for example by setting the delay time on the Emergency power-off switch to 0. The Compax3 drive will then be turned off immediately in 2 channels and will not be able to generate any more torque. Please take into consideration that the motor will not brake and a coasting down of the motor may result in hazards. If this is the case, then a „Safe Standstill“ is not permitted in Stop Category 0.

3.4.2.1 Sample circuit example of Compax3 devices without fieldbus option

Sample circuit for the following Compax3 devices:

Compax3 I10 T10

- ◆ Input "Energize": I0: X12/6
- ◆ Output "Controller Feedback": O2: X12/4



The Stop Category 1 described here cannot be used in the „Torque Controller“ operating mode.

At least Firmware Version V02.01.12 is required to be able to implement the application described here for the Compax3 I10T10 device (the Firmware Version of Compax3 can be seen with the C3 ServoManager under "Online Device Identification").

Compax3 I11 T11:

- ◆ Input "Energize": I2: X12/8
- ◆ Output "Controller Feedback": O2: X12/4

Compax3 Ixx T30 and Compax3 Ixx T40:

- ◆ Input "Energize": apply the Enable Input of the MC_Power - module (IEC-program) to a Compax3 input.
- ◆ Output "Controller Feedback": apply the Status output of the MC_Power - module (IEC-program) to a Compax3 output.



If the Compax3 „Safe Standstill“ feature is required or used for a system or machine, the two error messages „Motor Stalled“ and „Tracking“ must not be turned off for a programmable Compax3 drive (T30, T40) with the „C3 Errormask“ function module.

Structure of Compax3 devices without fieldbus option:

- ◆ 2 Compax3 devices (the sample circuit also applies to one or more devices with appropriate adjustments)
- ◆ 1 Emergency Power-off module (BH5928.47)
- ◆ 1 safety door monitor (BD5985N)
Note: With safety door monitor BD5985N, the safety door must be opened and closed again every time after turning on the 24 V power supply so that the Emergency power-off module can be acknowledged and reset. To avoid this, safety door monitors with an additional simulation entry can also be used.
- ◆ 4 relays (K1, ... K4)
- ◆ 1 Emergency power-off switch
- ◆ Hazardous area accessible via a safety door with safety door switch S1 and S2
- ◆ 3 buttons (S3, ... S5)

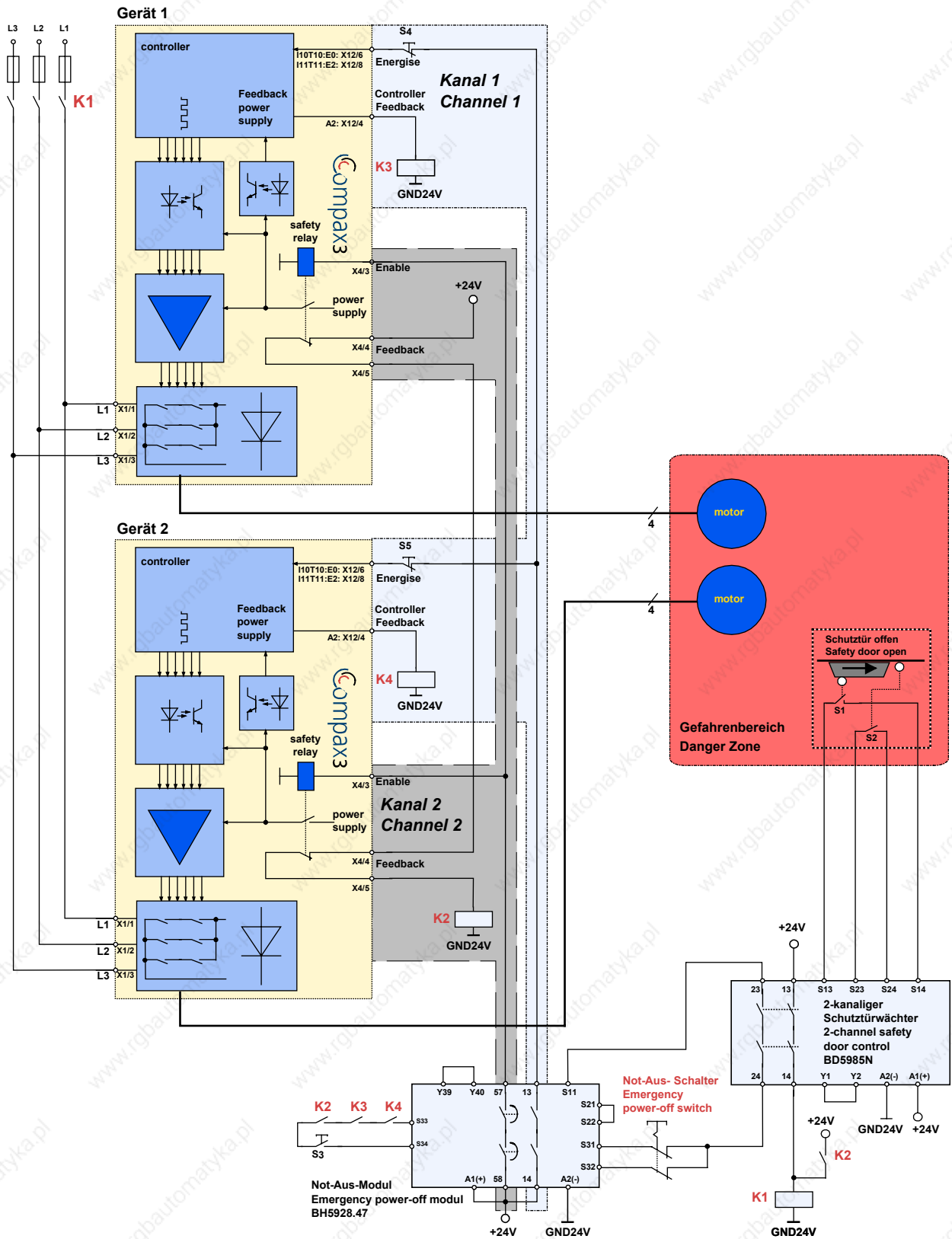

Switches and buttons:

| | |
|-----|---------------------------------------|
| S1: | Closed when the safety door is closed |
| S2: | Closed when the safety door is closed |
| S3: | Activate Emergency power-off module |
| S4: | Guide Device 1 to a currentless state |
| S5: | Guide Device 2 to a currentless state |

Basic functions:**Compax3 devices disabled by:**

Channel 1: Energize – input to “0” through open contacts of Emergency Power-off Module (13-14)

Channel 2: Enable input to "0" through open contacts of Emergency power-off module (57 -58)

Activate Emergency power-off module

Before the Compax3 can be placed in operation, the Emergency power-off module must be activated by a pulse to Input S33/S34.

Prerequisite:

- ◆ S3 closed
- ◆ Safety door closed: This is required before the safety door monitor enables the Emergency power-off module via Input S11 (by closing the contacts between 23 and 24).
- ◆ Current to K2, K3 and K4
- ◆ K2: receives current if all Compax3's are currentless (contact closed in currentless state) = Channel 2 feedback
- ◆ K3: receives current if Compax3 Device 1 is currentless (output = „1“ in currentless state) = Channel 1 feedback
- ◆ K4: receives current if Compax3 Device 2 is currentless (output = „1“ in currentless state) = Channel 1 feedback

If S33 and S34 of the Emergency power-off module are briefly connected (pulse) the contacts will be closed (between 13 and 14 and between 57 and 58)

Supplying current to Compax3

- ◆ Compax3 devices are enabled by the Energize input and the Enable input via the Emergency power-off module. (If a fault is still pending on Compax3, it must previously be reset. The acknowledge/reset function depends on the type of the Compax3 device).
- ◆ Power is supplied to K1 and the mains power voltage is switched on by a K2 contact or by the closed safety door.
- ◆ The motors are energized with current.

Summary: Compax3 is not energized with current unless the feedback functions via K2, K3 and K4 are capable of functioning.

Case 1: Normal access to the hazardous area**Activate Emergency power-off switch**

Disconnecting the connection between S11 and S31 /S32 (2 channels) deactivates the Emergency power-off module and causes Contacts 13 - 14 to open immediately.

Channel 1: Compax3 devices receive the command via the Energize input to guide the drive to a currentless state (using the ramp configured in the C3 ServoManager for "drive disable").

Channel 1 feedback: The "Controller Feedback" Compax3 outputs supply current to Relays K3 and K4.

Channel 2: After the delay time set in the Emergency power-off module, (this time must be set so that all drives are stopped after it has elapsed) the contacts

between 57 and 58 open, which in turn deactivates the Enable inputs of the Compax3 devices.

Channel 2 feedback: Power is only supplied to the K2 relay via the series circuit of the Feedback contacts if all Compax3's are currentless: "Safe standstill" state reached.

Now the safety door can be opened and access to the hazardous area is possible.

After the safety door is opened, the safety door monitor opens its contacts.

Mains power continues to be supplied to Compax3 devices if the K2 relay is receiving current (so that current is supplied to K1) and the "Safe Standstill" is thus acknowledged.

Case 2: Opening the safety door directly

After the safety door is opened, the safety door monitor opens its contacts.

The supply of mains power is disconnected by the safety door monitor.

After the storage capacity of the power DC bus is used up, the motors gradually come to a standstill.

Caution! The mains power voltage is turned on again by the feedback from Channel 2, since the feedback contacts are closed in the basic state. A "Safe Standstill" is nevertheless still ensured after the motors have come to a standstill.

Function of the K1 relay

The effect of the K1 relay in the event of a fault is as follows: If the Feedback contact (Channel 2 feedback) cannot be closed because of a defective Compax3 device, the supply of mains power is interrupted when the safety door is open (safety door monitor contacts open; no feedback via Channel 2).

3.4.2.2 Sample circuit example of Compax3 devices with fieldbus option

Sample circuit for the following Compax3 devices:

Compax3 I20 T11

Compax3 I20 T11

Layout:

- ◆ 2 Compax3 devices
- ◆ 1 Emergency Power-off module (BH5928.47)
- ◆ 1 safety door monitor (BD5985N)
Note: With safety door monitor BD5985N, the safety door must be opened and closed again every time after turning on the 24 V power supply so that the Emergency power-off module can be acknowledged and reset. To avoid this, safety door monitors with an additional simulation entry can also be used.
- ◆ 3 relays (K1, ... K3)
- ◆ 1 Emergency power-off switch
- ◆ Hazardous area accessible via a safety door with safety door switch S1 and S2
- ◆ 1 button (S3)

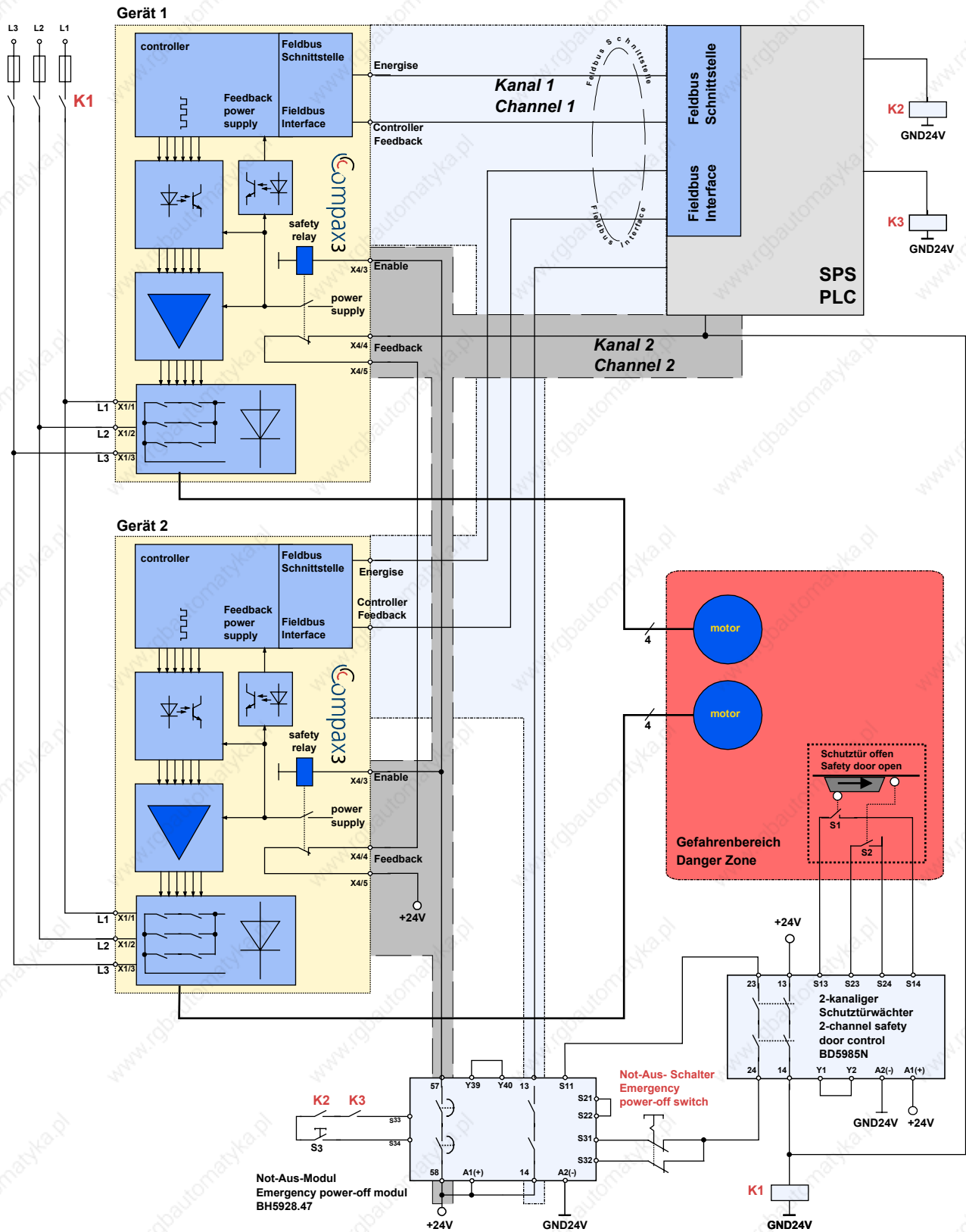

Switches and buttons:

| | |
|-----|---------------------------------------|
| S1: | Closed when the safety door is closed |
| S2: | Closed when the safety door is closed |
| S3: | Activate Emergency power-off module |

Basic functions:**Compax3 devices disabled by:**

Channel 1: Energize deactivated by PLC due to open contacts of the Emergency power-off module (13 -14)

Channel 2: Enable input to "0" through open contacts of Emergency power-off module (57 -58)

Activate Emergency power-off module

Before the Compax3 can be placed in operation, the Emergency Power-off module must be activated by a pulse to Input S33/S34.

Prerequisite:

- ◆ S3 closed
- ◆ Safety door closed: This is required before the safety door monitor enables the Emergency power-off module via Input S11 (by closing the contacts between 23 and 24).
- ◆ K2 and K3 via PLC program:
- ◆ K2: receives current if Compax3 Device 1 and 2 are currentless (evaluation of Compax3 status word) = Channel 1 feedback
- ◆ K3: receives current if Compax3 Device 1 and 2 are currentless (evaluation of Channel 2 feedback) = Channel 2 feedback

If S33 and S34 of the Emergency power-off module are briefly connected (pulse) the contacts will be closed (between 13 and 14 and between 57 and 58).

Supplying current to Compax3

- ◆ The PLC enables the Compax3 devices by means of the control word and the Emergency power-off module enables the Compax3 devices by means of the Enable input. (if a fault is still pending on Compax3, it must be previously acknowledged/reset)
- ◆ Power is supplied to K1 and the mains power voltage is switched on by the feedback output (Channel 2) or by the closed safety door.
- ◆ The motors are energized with current.

Summary: Compax3 is not energized with current unless the feedback functions via K2 and K3 are capable of functioning.

Case 1: Normal access to the hazardous area**Activate Emergency power-off switch**

Disconnecting the connection between S11 and S31 /S32 (2 channels) deactivates the Emergency power-off module and causes Contacts 13 - 14 to open immediately.

The PLC evaluates this and responds as follows:

Channel 1: Compax3 devices receive the command via the control word ¹to guide the drive to a currentless state (using the ramp configured in the C3 ServoManager for "drive disable").

Channel 1 feedback: The Compax3 feedback via the status word ² is evaluated by the PLC.

¹ Example for the assignment of the control word (CW) to guide the drive to a stop and switch: Profibus: CW.2 = "0" (OFF3) standstill via ramp (FSTOP3) and then currentless-switch. CANopen: CW.3 = "0" standstill via STOP ramp, then with CW.0 currentless-switch.

² Example for the assignment of the status word (SW) to guide the drive to a standstill and switch: Profibus: SW.6 = "1" switch-on disable (motor currentless). CANopen: SW.1 = "02" Ready to Switch on (motor currentless).

Channel 2: After the delay time set in the Emergency power-off module, (this time must be set so that all drives are stopped after it has elapsed) the contacts between 57 and 58 open, which in turn deactivates the Enable inputs of the Compax3 devices.

Channel 2 feedback: „Safe Standstill“ is reported back as feedback through the series circuit of the Feedback contacts if all Compax3's are currentless. The PLC evaluates this and activates the K2 and K3 relays if the feedback was from Channel 1 and 2.

Now the safety door can be opened and access to the hazardous area is possible. After the safety door is opened, the safety door monitor opens its contacts. Compax3 devices continue to receive mains power via the feedback from Channel 2.

Case 2: Opening the safety door directly

After the safety door is opened, the safety door monitor opens its contacts.

The supply of mains power is disconnected by the safety door monitor.

After the storage capacity of the power DC bus is used up, the motors gradually come to a standstill.

Caution! The mains power voltage is turned on again by the feedback from Channel 2, since the feedback contacts are closed in the basic state. A "Safe Standstill" is nevertheless still ensured after the motors have come to a standstill.

Function of the K1 relay

The effect of the K1 relay in the event of a fault is as follows: If the Feedback contact (Channel 2 feedback) cannot be closed because of a defective Compax3 device, the supply of mains power is interrupted when the safety door is open (safety door monitor contacts open; no feedback via Channel 2).

3.4.2.3 Sample circuit for C3 powerPLmC multi-axis application



If the Compax3 "Safe Standstill" feature is required or used for a system or machine, the two error messages "Motor Stalled" and "Tracking" must not be turned off with the "C3 Errormask" function module.

Layout:

- ◆ 1 Compax3 with powerPLmC
- ◆ n Compax3 devices
- ◆ 1 Emergency Power-off module (BH5928.47)
- ◆ 1 safety door monitor (BD5985N)
Note: With safety door monitor BD5985N, the safety door must be opened and closed again every time after turning on the 24 V power supply so that the Emergency power-off module can be acknowledged and reset. To avoid this, safety door monitors with an additional simulation entry can also be used.
- ◆ 3 relays (K1, ... K3)
- ◆ 1 Emergency power-off switch
- ◆ Hazardous area accessible via a safety door with safety door switch S1 and S2
- ◆ 1 button S3

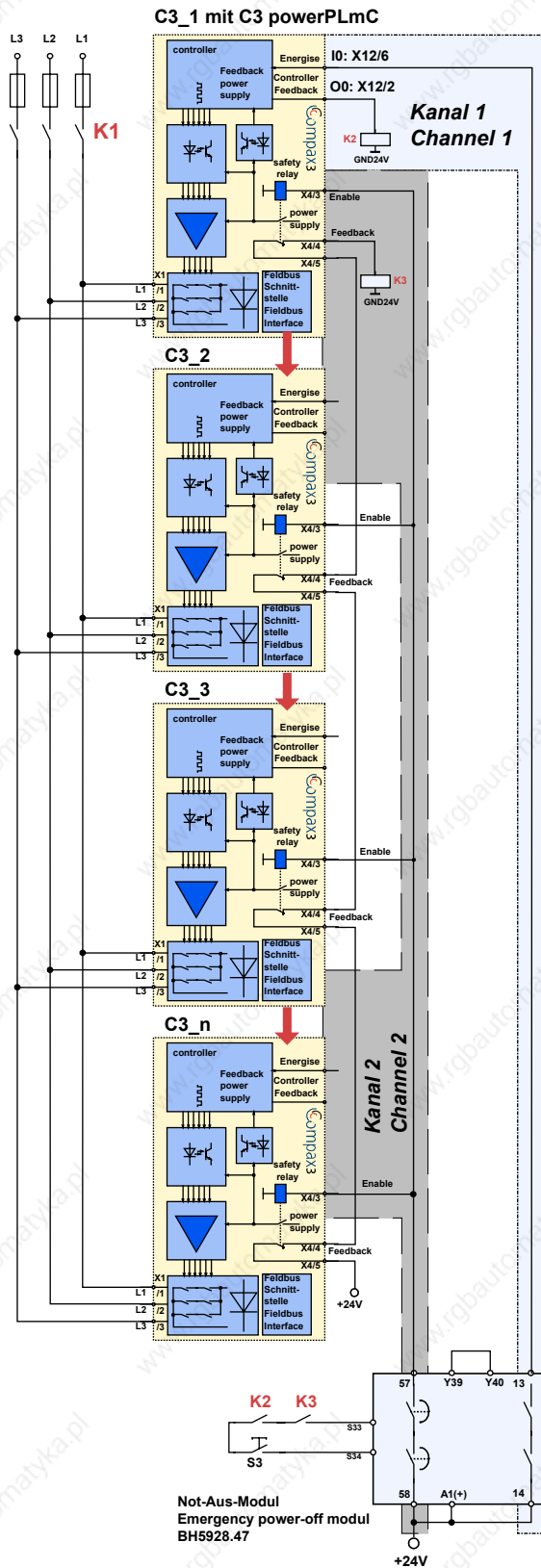

C3_1 powerPLmC Program (Kanal 1; Channel 1)

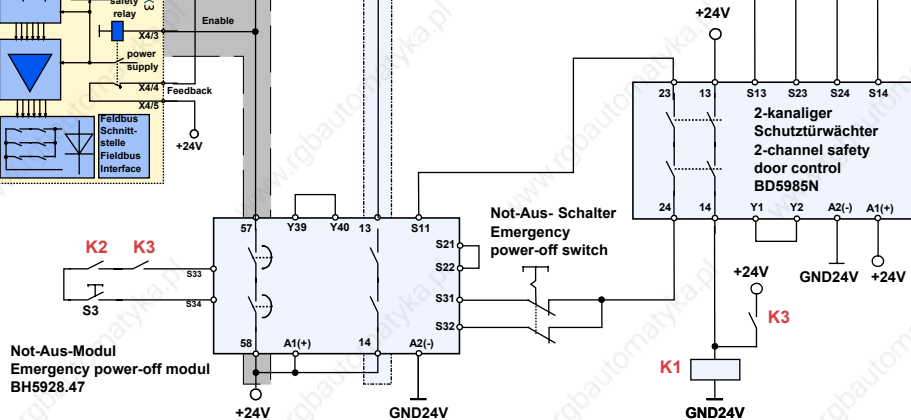
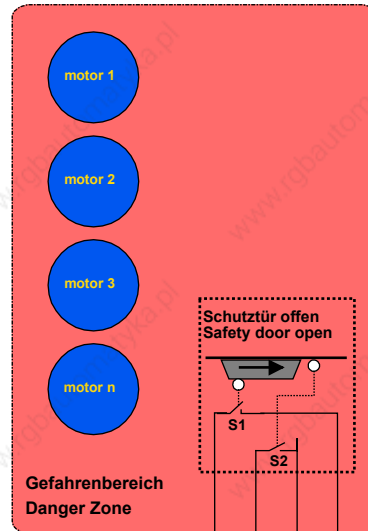
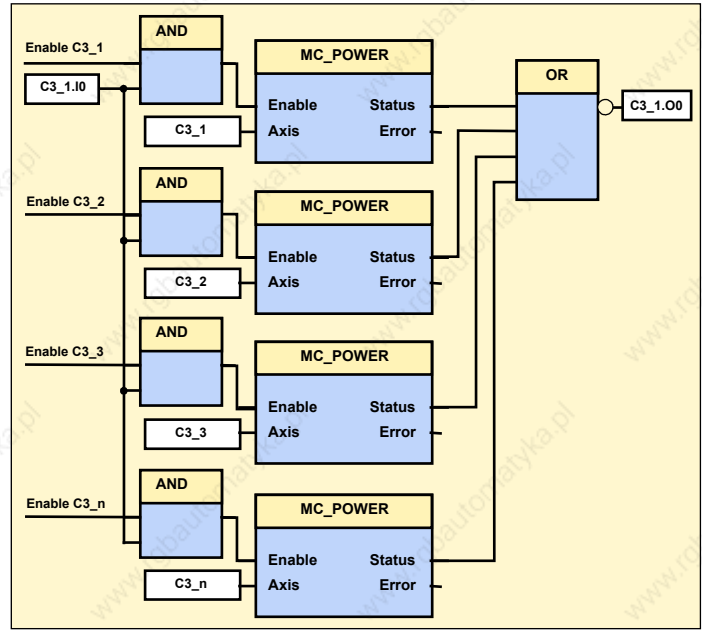

Switches and buttons:

| | |
|-----|---------------------------------------|
| S1: | Closed when the safety door is closed |
| S2: | Closed when the safety door is closed |
| S3: | Activate Emergency power-off module |

Basic functions:**Compax3 devices disabled by:**

Channel 1: Energize input (I0) to C3_1 (with powerPLmC) to "0" through open contacts of Emergency power-off module (13 -14)

Channel 2: Enable inputs of individual Compax3's to "0" through open contacts of Emergency power-off module (57 -58)

Activate Emergency power-off module

Before the Compax3 can be placed in operation, the Emergency power-off module must be activated by a pulse to Input S33/S34.

Prerequisite:

- ◆ S3 closed
- ◆ Safety door closed: This is required before the safety door monitor enables the Emergency power-off module via Input S11 (by closing the contacts between 23 and 24).
- ◆ Current flowing to K2 and K3
- ◆ K3: receives current if all Compax3's are currentless (contact closed in currentless state) = Channel 2 feedback
- ◆ K2: receives current if all Compax3 devices are currentless (Output O0 = "1" if the MC_POWER components of all devices have the status „FALSE“.) = Channel 1 feedback

If S33 and S34 of the Emergency power-off module are briefly connected (pulse) the contacts will be closed (between 13 and 14 and between 57 and 58)

Supplying current to Compax3

- ◆ The Enable input is activated on all Compax3's by the Emergency power-off module.
- ◆ Input I0 is also activated (= "1") on Compax3 C3_1, which makes it possible to activate the ENABLE inputs of the MC_Power modules with the AND modules. (If a fault is still pending on Compax3, it must previously be reset. The acknowledge/reset function depends on the type of the Compax3 device).
- ◆ Power is supplied to K1 and the mains power voltage is switched on by a K2 contact or by a closed safety door.
- ◆ The motors are energized with current.

Summary: Compax3 is not energized with current unless the feedback functions via K2 and K3 are capable of functioning.

Case 1: Normal access to the hazardous area**Activate Emergency power-off switch**

Disconnecting the connection between S11 and S31 /S32 (2 channels) deactivates the Emergency power-off module and causes Contacts 13 - 14 to open immediately.

Channel 1: The MC_POWER modules are deactivated for all Compax3's by Input I0 = "0" on device C3_1 (with powerPLmC) via the AND modules. Compax3 devices are guided to a standstill and the current is switched off (by means of the ramp for "drive disable) configured in the C3 ServoManager.

Channel 1 feedback: Output O0 = "1" if the MC_POWER components of all devices have the status „FALSE“.

Channel 2: After the delay time set in the Emergency power-off module, (this time must be set so that all drives are stopped after it has elapsed) the contacts between 57 and 58 open, which in turn deactivates the Enable inputs of the Compax3 devices.

Channel 2 feedback: Power is only supplied to the K3 relay via the series circuit of the Feedback contacts if all Compax3's are currentless: "Safe standstill" state reached.

Now the safety door can be opened and access to the hazardous area is possible.

After the safety door is opened, the safety door monitor opens its contacts.

Mains power continues to be supplied to Compax3 devices if the K3 relay is receiving current (so that current is supplied to K1) and the "Safe Standstill" is thus acknowledged.

Case 2: Opening the safety door directly

After the safety door is opened, the safety door monitor opens its contacts.

The supply of mains power is disconnected by the safety door monitor.

After the storage capacity of the power DC bus is used up, the motors gradually come to a standstill.

Caution! The mains power voltage is turned on again by the feedback from Channel 2, since the feedback contacts are closed in the basic state. A "Safe Standstill" is nevertheless still ensured after the motors have come to a standstill.

Function of the K1 relay

The effect of the K1 relay in the event of a fault is as follows: If the Feedback contact (Channel 2 feedback) cannot be closed because of a defective Compax3 device, the supply of mains power is interrupted when the safety door is open (safety door monitor contacts open; no feedback via Channel 2).

4. Technical Data

Mains connection: Compax3 S0xx V2

| Controller type | S025 V2 | S063 V2 |
|--------------------------------|--|------------------------------------|
| Mains voltage | Single phase 230VAC + 10% 80-230VAC+10% / 50-60Hz | |
| Rated input current | 6Aeff | 16Aeff |
| Maximum fuse rating per device | 10A (automatic circuit breaker K) | 16 A (automatic circuit breaker K) |

Mains connection Compax3 Sxxx V4

| Controller type | S038 V4 | S075 V4 | S150 V4 | S300 V4 |
|--------------------------------|---|------------------------------------|---------|-----------------------------------|
| Mains voltage | Three-phase 3*400VAC 80-480 VAC+10% / 50-60 Hz | | | |
| Rated input current | 6Aeff | 10 Aeff | 16Aeff | 22Aeff |
| Maximum fuse rating per device | 10A (automatic circuit breaker K) | 16 A (automatic circuit breaker K) | | 25A (automatic circuit breaker K) |

Output data: Compax3 S0xx V2

| Controller type | S025 V2 | S063 V2 |
|-----------------------------------|--------------|-----------------|
| Output voltage (at 1*230 V) | 3x 0-230V | 3x 0-230V |
| Rated output current (at 1*230 V) | 2.5Aeff | 6.3Aeff |
| Pulse current | 5Aeff for 5s | 12.6Aeff for 5s |
| Power [hp] | 1kVA | 2.5kVA |
| Switching frequency | 8kHz | 8kHz |
| Power loss for In [Pv] | 30W | 60W |
| Efficiency | 95% | 96% |

The currents are valid for the power output stage clock frequency of 8kHz normally set.

Output data Compax3 Sxxx V4

| Controller type | S038 V4 | S075 V4 | S150 V4 | S300 V4 |
|-------------------------------------|----------------|---------------|---------------|---------------|
| Output voltage (at 3*400 VAC) | 3x 0-400V | | | |
| Rated output current (at 3*400 VAC) | 3.8Aeff | 7.5Aeff | 15Aeff | 30Aeff |
| Pulse current (at 400VAC) | 7.5Aeff for 5s | 15Aeff for 5s | 30Aeff for 5s | 60Aeff for 5s |
| Power [hp] (at 400VAC) | 2.5kVA | 5kVA | 10kVA | 20kVA |
| Switching frequency | 8kHz | 8kHz | 4kHz | 4kHz |
| Power loss for In | 80 W | 120W | 160W | 350W |
| Efficiency | 94% | 95% | 97% | 97% |

Resulting nominal and peak currents depending on the switching frequency of the power output stage

Compax3 S0xx V2 at 230VAV

| Power output stage switching frequency | | S025 V2 | S063 V2 |
|--|--------------------|---------------------------|----------------------------|
| 8kHz pre-set | $I_{nominal}$ | 2.5A_{eff} | 6.3A_{eff} |
| | $I_{peak} (<5s)$ | 5.5A_{eff} | 12.6A_{eff} |
| 16kHz | $I_{nominal}$ | 2.5A _{eff} | 5.5A _{eff} |
| | $I_{peak} (<2,5s)$ | 5.5A _{eff} | 12.6A _{eff} |

Compax3 S0xx V4 at 3*400VAC

| Power output stage switching frequency | | S038 V4 | S075 V4 | S150 V4 | S300 V4 |
|--|--------------------|---------------------------|----------------------------|--------------------------|--------------------------|
| 4kHz pre-set | $I_{nominal}$ | - | - | 15A_{eff} | 30A_{eff} |
| | $I_{peak} (<5s)$ | - | - | 30A_{eff} | 60A_{eff} |
| 8kHz | $I_{nominal}$ | 3.8A_{eff} | 7.5A_{eff} | 10.0A _{eff} | 26A _{eff} |
| | $I_{peak} (<2,5s)$ | 9.0A_{eff} | 15.0A_{eff} | 20.0A _{eff} | 52A _{eff} |
| 16kHz | $I_{nominal}$ | 2.5A _{eff} | 3.7A _{eff} | 5.0A _{eff} | 14A _{eff} |
| | $I_{peak} (<2,5s)$ | 5.0A _{eff} | 10.0A _{eff} | 10.0A _{eff} | 28A _{eff} |

Compax3 S0xx V4 at 3*480VAC

| Power output stage switching frequency | | S038 V4 | S075 V4 | S150 V4 | S300 V4 |
|--|--------------------|---------------------------|----------------------------|----------------------------|--------------------------|
| 4kHz pre-set | $I_{nominal}$ | - | - | 13.9A_{eff} | 30A_{eff} |
| | $I_{peak} (<5s)$ | - | - | 30A_{eff} | 60A_{eff} |
| 8kHz | $I_{nominal}$ | 3.8A_{eff} | 6.5A_{eff} | 8.0A _{eff} | 21.5A _{eff} |
| | $I_{peak} (<2,5s)$ | 7.5A_{eff} | 15.0A_{eff} | 16.0A _{eff} | 43A _{eff} |
| 16kHz | $I_{nominal}$ | 2.0A _{eff} | 2.7A _{eff} | 3.5A _{eff} | 10A _{eff} |
| | $I_{peak} (<2,5s)$ | 4.0A _{eff} | 8.0A _{eff} | 7.0A _{eff} | 20A _{eff} |

The values marked with grey re the pre-set values (standard values)!

Accuracy at the motor

| | |
|---------------------------------|--|
| For option F10: Resolver | <ul style="list-style-type: none"> ◆ Position resolution: 16 bits (= 0.005°) ◆ Absolute accuracy: ±0.167° |
| For option F11: SinCos | <ul style="list-style-type: none"> ◆ Position resolution: 19 bits (= 0.0002°) ◆ Absolute accuracy: ±0.005° |

| | |
|--------------------------------------|--|
| For option F12: Direct drives | <ul style="list-style-type: none"> ◆ Position resolution per pitch resp. per revolution (max. 24bit): <ul style="list-style-type: none"> ◆ the analog hall sensors: 13 bits ◆ For Sine-Cosine: 13Bit + log₂ (Strokes / Pitch) ◆ For TTL (ES422): 2 + log₂ (Strokes / Pitch) <p>For rotational motors you have to use revolutions instead of pitch.</p> <ul style="list-style-type: none"> ◆ Accuracy: The accuracy depends on the accuracy of the encoders used. |
|--------------------------------------|--|

Control voltage 24 VDC

| | |
|---|---|
| Controller type | Compax3 |
| Voltage range | 21 - 27VDC |
| Current drain of the device | 0.8 A |
| Total current drain | 0.8 A + Total load of the digital outputs + current for the motor holding brake |
| Ripple | 0.5Vpp |
| Requirement according to safe extra low voltage (SELV) | yes |

Motors and feedback systems supported

| | |
|--|---|
| Motors | <ul style="list-style-type: none"> ◆ Sinusoidal commutated synchronous motors up to maximum rotation speed of 9000 rpm. ◆ 3 phase synchronous direct drives ◆ Maximum rotating field frequency 600Hz |
| Direct drives | |
| <ul style="list-style-type: none"> ◆ Linear motors ◆ Torque motors | |
| Position encoder (Feedback) | Option F10: Resolver |
| Litton: | <ul style="list-style-type: none"> ◆ JSSBH-15-E-5 ◆ JSSBH-21-P4 ◆ RE-21-1-A05 ◆ RE-15-1-B04 |
| Tamagawa: | ◆ 2018N321 E64 |
| Siemens: | ◆ 23401-T2509-C202 |
| | Option F11: SinCos® |
| | <ul style="list-style-type: none"> ◆ Singleturn (Stegmann) ◆ Multiturn (Stegmann) Absolute position up to 4096 motor revolutions. |

| Special encoder systems for direct drives | Option F12 |
|---|--|
| Analog hall sensors | <ul style="list-style-type: none"> ◆ Sine - cosine signal (max. $5V_{ss}^3$; typical 1V_{ss}) 90° offset ◆ U-V Signal (max. $5V_{ss}^4$; typical 1V_{ss}) 120° offset. ◆ |
| Encoder (linear or rotatory) | <ul style="list-style-type: none"> ◆ Sine-cosine (max. $5V_{ss}^5$; typical 1V_{ss}) (max. 400kHz) or ◆ TTL (RS422) (max. 5MHz) with the following modes of commutation: <ul style="list-style-type: none"> ◆ Automatic commutation or ◆ Digital hall sensors |
| Distance coded feedback systems | <ul style="list-style-type: none"> ◆ Distance coding with 1V_{SS} - Interface ◆ Distance coding with RS422 - Interface (Encoder) |

Interfaces

Interface selection by external plug contact assignment

| | |
|----------------------------|--|
| RS232 | <ul style="list-style-type: none"> ◆ 115200 baud ◆ Word length: 8 bits, 1 start bit, 1 stop bit ◆ Hardware handshake XON, XOFF |
| RS485 (2 or 4-wire) | <ul style="list-style-type: none"> ◆ 9600, 19200, 38400, 57600 or 115200 baud ◆ Word length 7/8 bit, 1 start bit, 1 stop bit ◆ Parity (can be switched off) even/odd ◆ 2 or 4-wire |

Motor holding brake output

| | |
|---|----------------|
| Controller type | Compax3 |
| Voltage range | 21 – 27VDC |
| Maximum output current (short circuit proof) | 1.6 A |

Brake operation Compax3 Sxxx V2

| Controller type | S025 V2 | S063 V2 |
|---|--------------|---------------|
| Capacitance / storable energy | 560µF / 15Ws | 1120µF / 30Ws |
| Minimum ballast - resistance | 100Ω | 56Ω |
| Recommended nominal power rating | 20 ... 60W | 60 ... 180W |
| Pulse power rating for 1s | 1kW | 2.5kW |

³ Max. differential input between SIN- (X13/7) and SIN+ (X13/8).

⁴ Max. differential input between SIN- (X13/7) and SIN+ (X13/8).

⁵ Max. differential input between SIN- (X13/7) and SIN+ (X13/8).

Compax3 Sxxx V4 brake operation

| Controller type | S038 V4 | S075 V4 | S150 V4 | S300 V4 |
|----------------------------------|--------------------|--------------------|---------------------|----------------------|
| Capacitance / storable energy | 235 μ F / 37Ws | 470 μ F / 75Ws | 690 μ F / 110Ws | 1100 μ F / 176Ws |
| Minimum ballast - resistance | 100 Ω | 56 Ω | 22 Ω | 15 Ω |
| Recommended nominal power rating | 60 ... 250W | 60 ... 500 W | 60 ... 1000 W | 60 ... 1000 W |
| Pulse power rating for 1s | 2.5kW | 5kW | 10 kW | 42kW |

Ballast resistors for Compax3

| Ballast resistor | Device | sustained | dynamic |
|-------------------------|------------------------------------|-----------|---------------------------------------|
| BRM8/01 (100 Ω) | Compax3 S025 V2 Compax3 S038 V4 | 60W | 250W (<1s; \geq 10s cooling time) |
| BRM5/01 (56 Ω) | Compax3 S063 V2 Compax3 S075 V4 | 180W | 2300W (<0.4s; \geq 8s cooling time) |
| BRM6/02 (33 Ω) | Compax3 S150 V4 | 570W | 6900 W (<1s; \geq 20s cooling time) |
| BRM4/01 (15 Ω) | Compax3 S300 V4 | 570W | 6900 W (<1s; \geq 20s cooling time) |
| BRM4/02 (15 Ω) | Compax3 S300 V4 | 740W | 8900W (<1s; \geq 20s cooling time) |
| BRM4/03 (15 Ω) | Compax3 S300 V4 | 1500W | 18kW (<1s; \geq 20s cooling time) |

Mechanical data

| Controller type | Dimensions HxWxD [mm] | Weight [kg] |
|-----------------|--------------------------|-------------|
| Compax3 S025 V2 | 199 x 84 x 172 | 2.0 |
| Compax3 S063 V2 | 199 x 100 x 172 | 2.5 |
| Compax3 S038 V4 | 260 x 100 x 172 | 3.5 |
| Compax3 S075 V4 | 260 x 115 x 172 | 4.3 |
| Compax3 S150 V4 | 260 x 160 x 172 | 6.8 |
| Compax3 S300 V4 | 380 x 175 x 172 | 10.9 |

Protection type IP20

Safety

| | |
|--|--|
| Safe standstill as per EN954-1, category 3 | <ul style="list-style-type: none"> ◆ For implementation of the "protection against unexpected start-up" function described in EN1037. ◆ Please note the circuit examples in the paper manual supplied. Circuit examples (see on page 34). |
|--|--|

UL certification

| | |
|----------------|------------------------|
| conform to UL: | ◆ according to UL508C |
| Certified | ◆ E-File_No.: E235 342 |

The UL certification is documented by a UL logo on the device (type specification plate)

"UL" - logo: 

Insulation requirements

| | |
|---|---|
| Protection class | Protection class I according to EN 50 178 (VDE 0160 part 1) |
| Protection against human contact with dangerous voltages | According to DIN VDE 0106, part 100 |
| Overvoltage category | Voltage class III according to HD 625 (VDE 0110-1) |
| Degree of contamination | Degree of contamination 2 according to HD 625 (VDE 0110 part 1) and EN 50 178 (VDE 0160 part 1) |

Ambient conditions

| | | |
|---|---|-------------------------------------|
| General ambient conditions | In accordance with EN 60 721-3-1 to 3-3 Climate (temperature/humidity/barometric pressure): Class 3K3 | |
| Permissible ambient temperature: | | |
| Operation Storage Transport | 0 to +45 C -25 to +70 C -25 to +70 C | Class 3K3 Class 2K3 Class 2K3 |
| Tolerated humidity: | No condensation | |
| Operation Storage Transport | <= 85% Class 3K3 <= 95% Class 2K3 <= 95% Class 2K3 | (Relative humidity) |
| Elevation of operating site | <=1000m above sea level for 100% load ratings Please inquire for greater elevations | |
| Cooling mode | Compax3 S025 V2 ... S150 V4: convection Compax3 S300 V4: force-ventilation via fan in the heat dissipator | |
| Sealing | IP20 protection class according to EN 60 529 | |
| EMC interference emission | Limit values according to EN 61 800-3, Class 'A' with integrated mains filter for up to 10 m cable length, otherwise with external mains filter | |
| EMC disturbance immunity | Limit values for industrial utilization according to EN 61 800-3 (includes EN 50 081-2 and EN 50 082-2) | |

EC directives and harmonised EC norms

| | |
|--|---|
| EC low voltage directive 73/23/EEC and RL 93/68/EEC | EN 50 178, General industrial safety norm Equipping electric power systems with electronic operating equipment HD 625, general electrical safety Insulation principles for electrical operating equipment EN 60 204-1, Machinery norm , partly applied |
| EC-EMC directive 89/336/EEC | EN 61 800-3, EMC norm Product standard for variable speed drives EN 50 081-2 ... 50 082-2, EN 61 000-4-2 ...61 000-4-5 |

5. Index

A

Analog / Encoder (plug X11) • 30

B

Ballast resistor • 23, 59

Ballast resistor / high voltage supply plug X2 for 230VAC devices • 23

Ballast resistor / high voltage supply plug X2 for 400VAC devices • 24

C

C3 IEC61131-3 - Debugger • 11

C3 MotorManager
configuration of almost any motor • 11

C3 ServoManager
configuring Compax3 , setup and optimization
• 10

C3 ServoManagers • 4

CamEditor
cam creation for C3 T40 • 11

CoDeSys - IEC61131-3 – development tool • 11

Compax3 device description • 19

Complements/corrections in manual and online help • 11

conditions of usage for the UL-certification • 9

Conditions of utilization • 15

Conditions of utilization for CE-conform operation • 15, 41

Conditions of utilization for UL certification • 17

Control voltage 24 VDC • 27

Control voltage 24VDC / enable (plug X4) • 27

D

Device assignment • 7

Digital inputs/outputs (plug X12) • 31

Direct drives • 9

F

Firmware - Download • 10

Function of the LEDs on the front panel • 21

G

General hazards • 12

I

Input wiring of digital inputs • 32

Installation and dimensions Compax3 • 34

Installation and dimensions of Compax3 S038 and S075 V4 • 36

Installation and dimensions of Compax3 S0xx V2 • 35

Installation and dimensions of Compax3 S150 V4 • 37

Installation and dimensions of Compax3 S300 V4 • 38

Introduction • 7

M

Manufacturer's Declaration of Conformity • 18

Motor / Motor brake (plug X3) • 26

Motor Connection • 26

Motor holding brake • 26

N

New Compax3 - functions • 9

New functions of the Compax3 - Software - tools • 10

New machine zero modes • 10

Notes on the Documents Supplied • 3

O

Optimization of the predefined external setpoint via the analog input • 9

Output wiring of digital outputs • 32

P

Plug and connector assignment Compax3 • 20

Plug assignment Compax3S0xx V2 • 20, 21, 23, 26, 27, 29, 33

Power supply • 20, 21

Power supply plug X1 for 230VAC devices • 21

Power supply plug X1 for 400 VAC devices • 22

R

Release 1/2004 • 9

Resolver • 33

Resolver / Feedback (connector X13) • 33

RS232 / RS485 interface (plug X10) • 29

RS232 plug assignment • 29

RS485 / RS232 - interface • 10

RS485 plug assignment • 29

S

Safe standstill • 39

Safe Standstill application example • 42

Safety function – safe standstill - • 27, 39

Safety function – Safe standstill - • 60

Safety Instructions • 12

Safety notes on the Safe standstill feature • 41

Safety-conscious working • 13

Sample circuit example of Compax3 devices with fieldbus option • 48

Sample circuit example of Compax3 devices without fieldbus option • 42

Sample circuit for C3 powerPLmC multi-axis application • 51

Setup - support • 10

Special safety instructions • 13
State of delivery • 19
Switching frequency of the power output stage
can be set • 9

T

Technical Data • 56
Type specification plate • 8

U

UL - certification • 9
Usage in accordance with intended purpose •
12

W

Warranty conditions • 14
Wiring of analog outputs • 30
Wiring of the analog input • 31

X

X1 • 21
X10 • 29
X11 • 30
X12 • 31
X13 • 33
X2 • 23
X3 • 26
X4 • 27