

SANMOTION

DC SERVO SYSTEMS

T



SANYO DENKI

Ver.3

CONCEPT
1

Simplified Setup Process for Optimum Operating Conditions

Auto-Tuning

A new auto-tuning algorithm improves system response by providing functions such as inertia identification, 5 auto-tuning modes, 30 levels of response, and parameter setting auto-save.

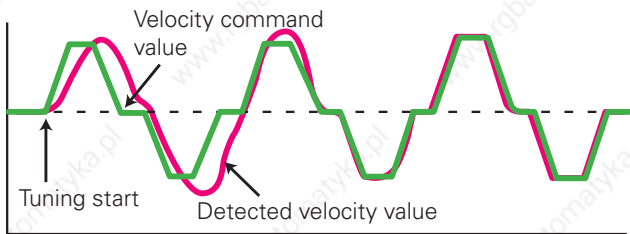

Test Function (JOG)

On-board JOG operation function is available for testing servo motor and servo amplifier connection without the need to connect to host device.

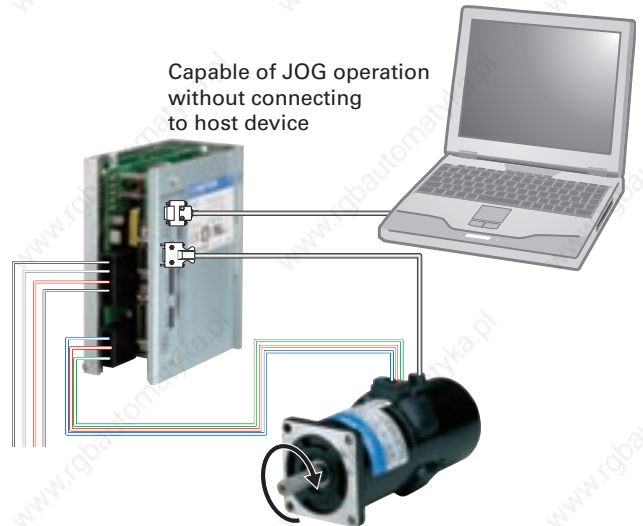

Setup Software is required.

Conformance to Overseas Standards

Our standard servo amplifier has attained the UL, c-UL and EN standards. You can also employ servo motors that have attained the EN standards.



All-in-One Control

Configurable parameters allow you to switch between control modes for torque, position or velocity.

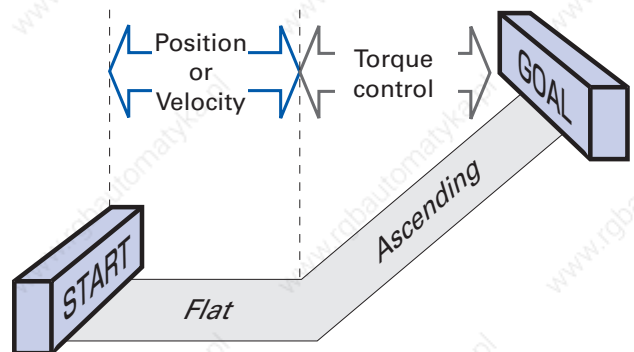

Setup Software

The setup software allows you to set parameters, view graphical displays of monitored position, velocity or torque waveforms, and perform system analysis.

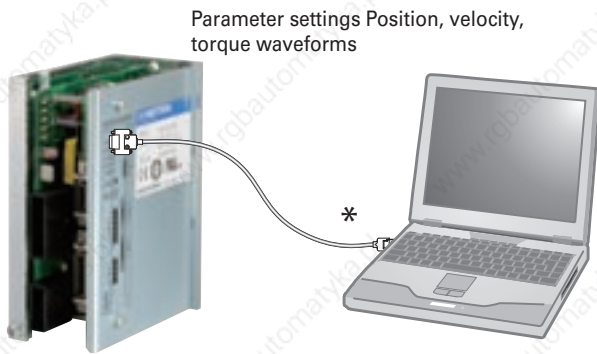

*Use optional cable AL-00490833-01 for PC connection

Multiaxial Monitor Function

The setup software allows up to 15 servo amplifiers to be monitored.



*Use optional cable For PC connection

Protection Code IP43

Protection code is IP43 for all models.



Shaft feedthrough and cable end are excluded.

Features and Functions

Model Number Nomenclature

System Configuration

Standard Specifications

External Wiring Diagram

Dimensions

Setup Software

Optional Equipment

CONCEPT
2

Improved Systems Precision and Shortened Cycle Time

High Response

A 4th-order notch filter reduces phase delay to suppress mechanical resonance and improve velocity response of equipment.

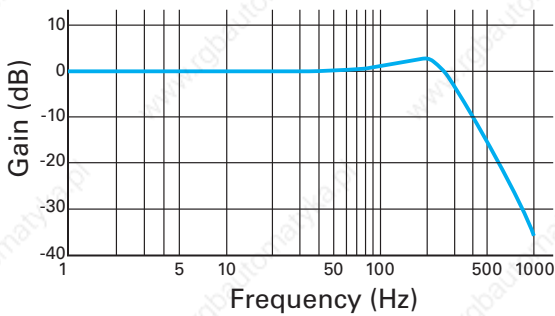

Vibration-damping Control

With feed-forward vibration suppression control, vibrations at the processing point and base of a machine can be suppressed through simple tuning procedures. Up to 4 types of vibration control frequencies can be selected.

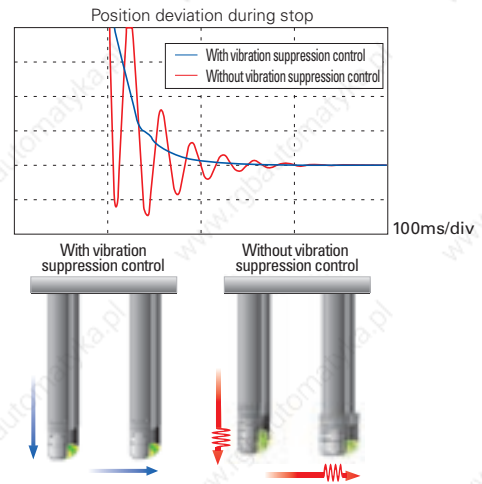

17-bit absolute encoder is required.

Shorter Position Settling Time

A new algorithm drastically shortens positioning settling time for equipment.

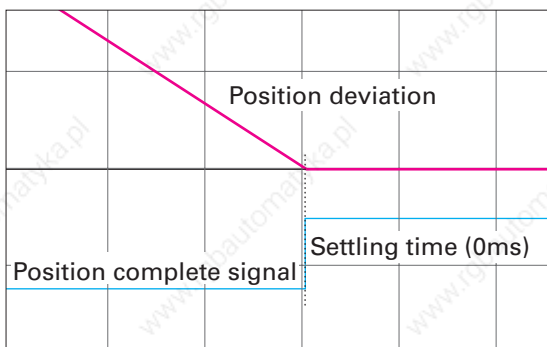

Example of positioning settling time 5ms/div in highly rigid machinery

Disturbance Suppression

It is possible to control impacts from other axes in case of multiaxial constitution, by using the new disturbance observer with extended applicable frequency.

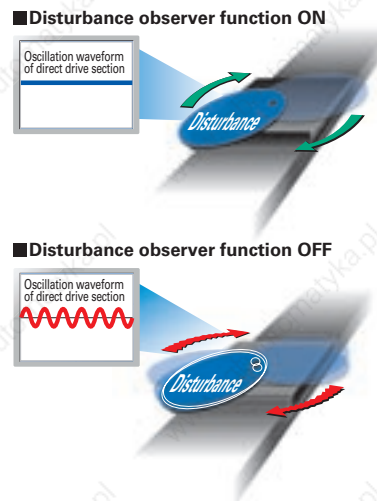

17-bit encoder is required.

CONCEPT
3

Curtailed Running Cost

High Resolution

Control suitable for the high-resolution incremental encoder and absolute encoder can be performed.

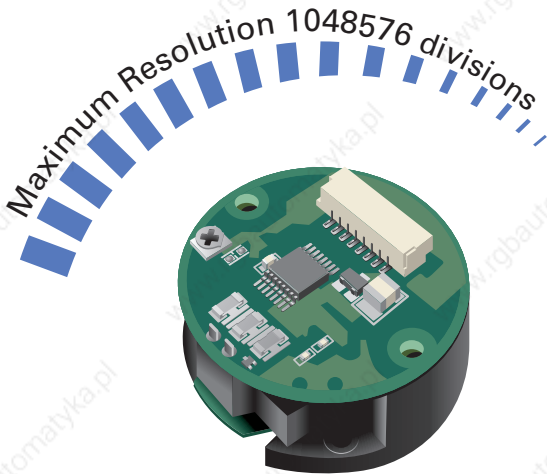

30% Reduction in Power Loss

A low-power loss module has been employed to reduce the power loss in the main circuit by 30%.

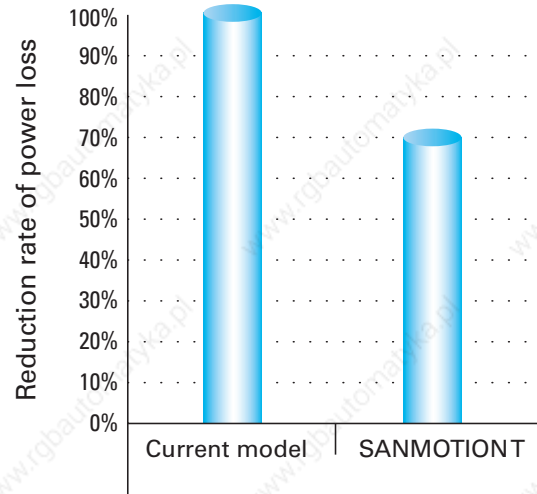

Features and Functions

Model Number Nomenclature

System Configuration

Standard Specifications

External Wiring Diagram

Dimensions

Setup Software

Optional Equipment

Servo Motor Standard Model Number List

| Rated Output | Outer diameter of motor | Encoder | Tachometer generator | Winding specifications | Model No. |
|--------------|-------------------------------------|-------------------------------------|----------------------|------------------------|-------------|
| 23W | φ41mm | — | — | 24V System | T402-011 |
| | | — | With | | T402T-011 |
| | | Incremental encoder (PP031) 1000P/R | — | | T402-011EL8 |
| 40W | φ41mm | — | — | 24V System | T404-011 |
| | | — | With | | T404T-011 |
| | | — | — | | T404-012 |
| | | — | With | 75V System | T404T-012 |
| | | Incremental encoder (PP031) 1000P/R | — | 24V System | T404-011EL8 |
| | | — | — | 75V System | T404-012EL8 |
| 60W | φ41mm | — | — | 24V System | T406-011 |
| | | — | — | 75V System | T406-012 |
| | | — | With | 24V System | T406T-011 |
| | | — | With | 75V System | T406T-012 |
| | φ51mm | Incremental encoder (PP031) 1000P/R | — | 24V System | T406-011EL8 |
| | | — | — | 75V System | T406-012EL8 |
| | | — | — | 24V System | T506-011 |
| | | — | — | 75V System | T506-012 |
| φ51mm | — | — | 24V System | T506T-011 | |
| | — | With | 75V System | T506T-012 | |
| | Incremental encoder (PP031) 1000P/R | — | 24V System | T506-011EL8 | |
| | — | — | 75V System | T506-012EL8 | |
| 110W | φ51mm | — | — | 75V System | T511-012 |
| | | — | With | | T511T-012 |
| | | Incremental encoder (PP031) 1000P/R | — | | T511-012EL8 |
| 200W | φ76mm | — | — | 75V System | T720-012 |
| | | — | With | | T720T-012 |
| | | Incremental encoder (PP031) 1000P/R | — | | T720-012EL8 |
| 300W | φ76mm | — | — | 75V System | T730-012 |
| | | — | With | | T730T-012 |
| | | Incremental encoder (PP031) 1000P/R | — | | T730-012EL8 |
| 400W | φ87.5mm | — | — | 75V System | T840-012 |
| | | — | With | | T840T-012 |
| | | Incremental encoder (PP031) 1000P/R | — | | T840-012EL8 |
| 500W | φ87.5mm | — | — | 75V System | T850-012 |
| | | — | With | | T850T-012 |
| | | Incremental encoder (PP031) 1000P/R | — | | T850-012EL8 |

For specifications on other model, please contact us.

Servo Amplifier Standard Model Number List

| Main power | Control power | Control system | Amp. capacity | Detector | Model No. |
|------------|---------------|----------------------------|---------------|--|----------------------|
| DC140V | DC24V | Pulse train, Speed, Torque | 20A | Incremental encoder | TS1A02AA |
| | | | 25A | Incremental encoder | TS1AA2AA |
| | | | 30A | Incremental encoder | TS1A03AA |
| | | Speed, Torque | 20A | Tachometer generator (Motor model T4) Tachometer generator (Motor model T5) | TS1A02AN TS1A02AP |
| | | | 25A | Tachometer generator (Motor model T5, T7) | TS1AA2AP |
| | | | 30A | Tachometer generator (Motor model T8) | TS1A03AP |
| DC50V | DC24V | Pulse train, Speed, Torque | 20A | Incremental encoder | TS1B02AA |
| | | | 25A | Incremental encoder | TS1BA2AA |
| | | Speed, Torque | 20A | Tachometer generator (Motor model T4) | TS1B02AN |
| | | | 25A | Tachometer generator (Motor model T4) Tachometer generator (Motor model T5) | TS1BA2AN TS1BA2AP |

For specifications on other model, please contact us.

Power unit

| Output capacity | Model No. |
|-----------------|-----------|
| 5A | TS1PA0500 |
| 10A | TS1PA1000 |
| 15A | TS1PA1500 |

Features and Functions

Model Number Nomenclature

System Configuration

Standard Specifications

External Wiring Diagram

Dimensions

Setup Software

Optional Equipment

Servo Motor / Power Unit Model Number Nomenclature

Servo Motor

Example : The model number is as follows when 200W rated output, 76mm outer diameter, incremental encoder (1000P/R), a brake, tachometer generator, gear (1/15 gear ratio), and 75V series voltage specification are selected for "SANMOTION" servo motor:

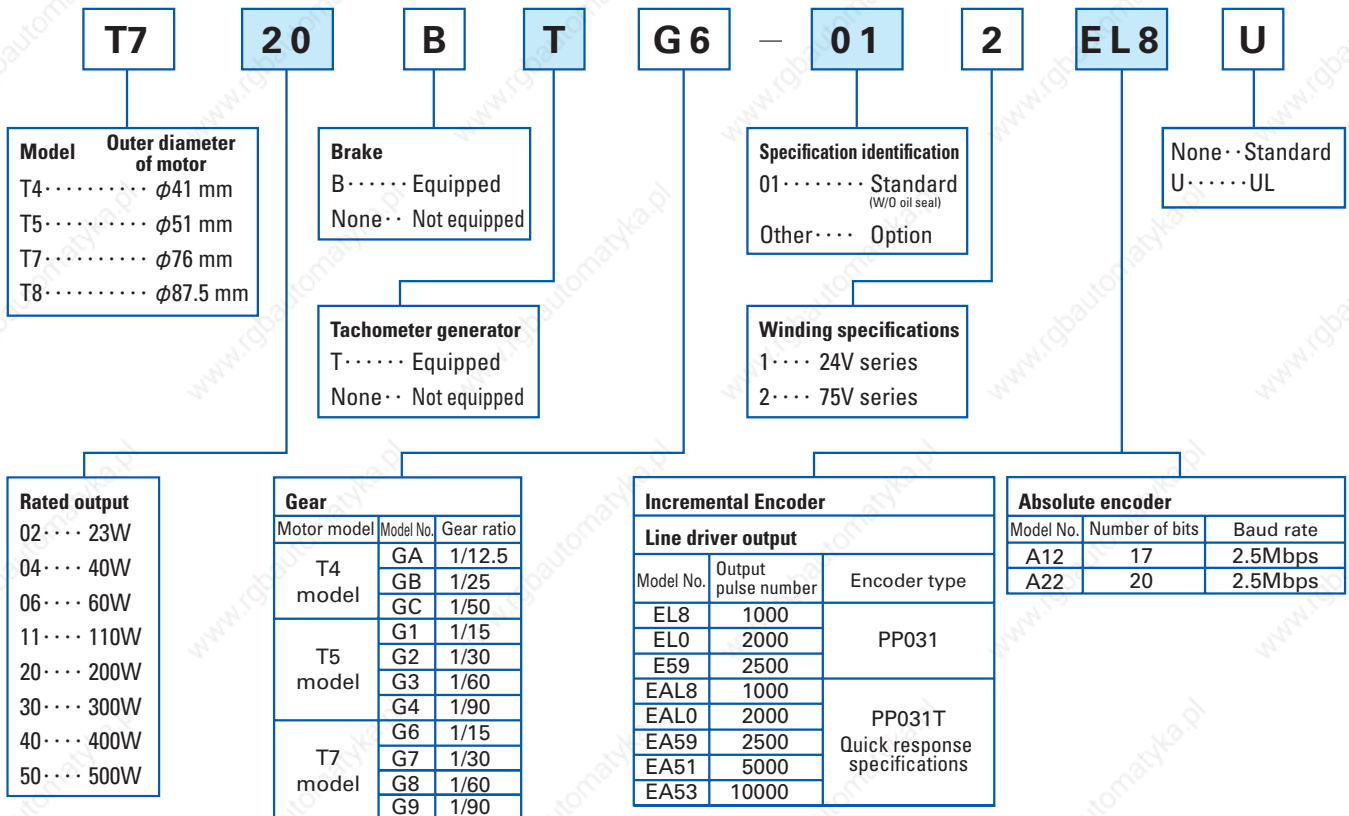

·No indication: No encoder

※T4 type can be equipped with either tacho-generator or encoder only. It cannot be equipped with brake oil seal.

※Motors with a rated output of 23W, 40W, and 60W support the 24V winding specification.

Power Unit

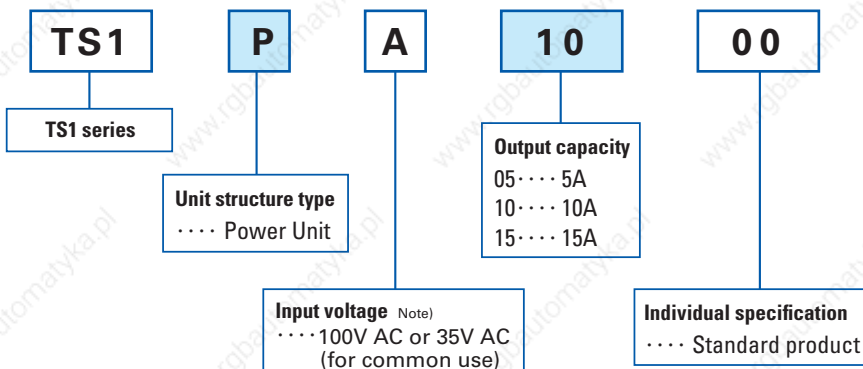

Note) Supply AC100V if the motor winding specification is 75V series and supply AC35V if it is 24V series.

Servo Amplifier Model Number Nomenclature

Servo Amplifier

Example: The model number is as follows when "SANMOTION T" series servo amplifier with input voltage of DC140V, 20A capacity, and incremental encoder (1000P/R).

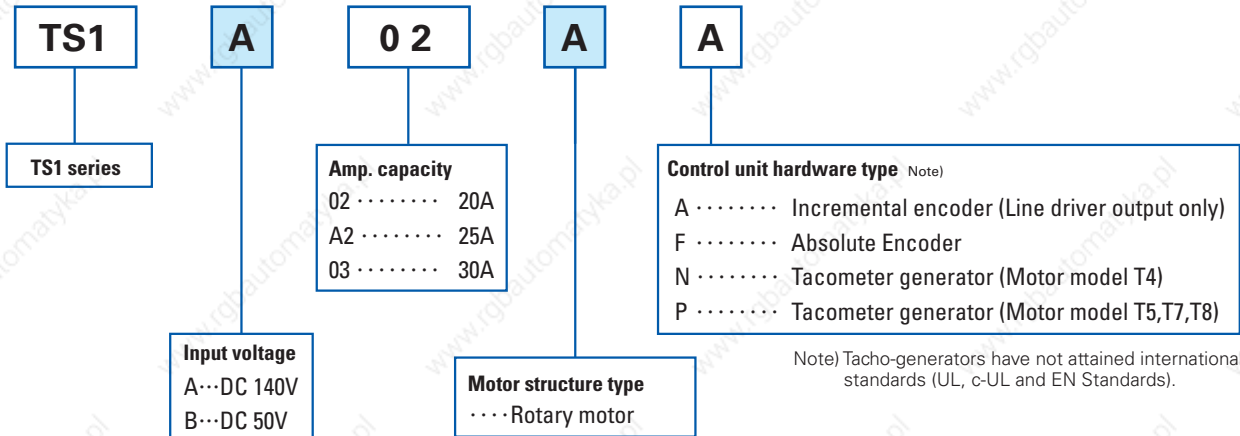

1) Compatible servo motor type ^{Note)}

| Input voltage-140V DC | | |
|-----------------------|---------------|------------------|
| Type of Amplifier. | Type of Motor | Factory settings |
| TS1A02A | T404-012 | √ |
| | T406-012 | |
| | T506-012 | |
| TS1AA2A | T511-012 | √ |
| | T720-012 | |
| | T730-012 | |
| TS1A03A | T840-012 | √ |
| | T850-012 | |

| Input voltage-50V DC | | |
|----------------------|---------------|------------------|
| Type of Amplifier. | Type of Motor | Factory settings |
| TS1B02A | T402-011 | √ |

2) Compatible encoder type ^{Note)}

| Incremental encoder | | | | |
|---------------------|------------------------------|---------------|------------|------------------|
| Format | Divisions per rotation [P/R] | Addressiation | Hard type. | Factory settings |
| Optical | 1000 | INC-E | A | √ |
| Optical | 2000 | INC-E | A | |
| Optical | 2500 | INC-E | A | |

| Absolute encoder | | | | | | | |
|------------------|---|------------------------------|-------------------|---------------|------------|---------|------------------|
| Format | Transmission format | Divisions per rotation [P/R] | Multiple rotation | Addressiation | Hard type. | Remarks | Factory settings |
| Optical | Half duplex start-stop synchronization 2.5M | 17bit | 16bit | PA035C-2.5MH | F | | √ |

3) Compatible tacometer generator

| Motor Model | Tacometer generator Model | Hard type |
|-------------|----------------------------|-----------|
| T4 | 3V / 1000min ⁻¹ | N |
| T5, T7, T8 | 7V / 1000min ⁻¹ | P |

4) Interface for control section ^{Note)}

| Control type | Factory settings |
|---------------------------------|------------------|
| Velocity control type | √ |
| Torque control type | |
| Position control type | |
| Velocity - Torque switch type | |
| Position - Torque switch type | |
| Position - Velocity switch type | |
| Internal velocity control type | |

Note) Please change the compatible servo motor, compatible encoder and the interface for control section using the set-up software.

Features and Functions

Model Number Nomenclature

System Configuration

Standard Specifications

External Wiring Diagram

Dimensions

Setup Software

Optional Equipment

System Configuration

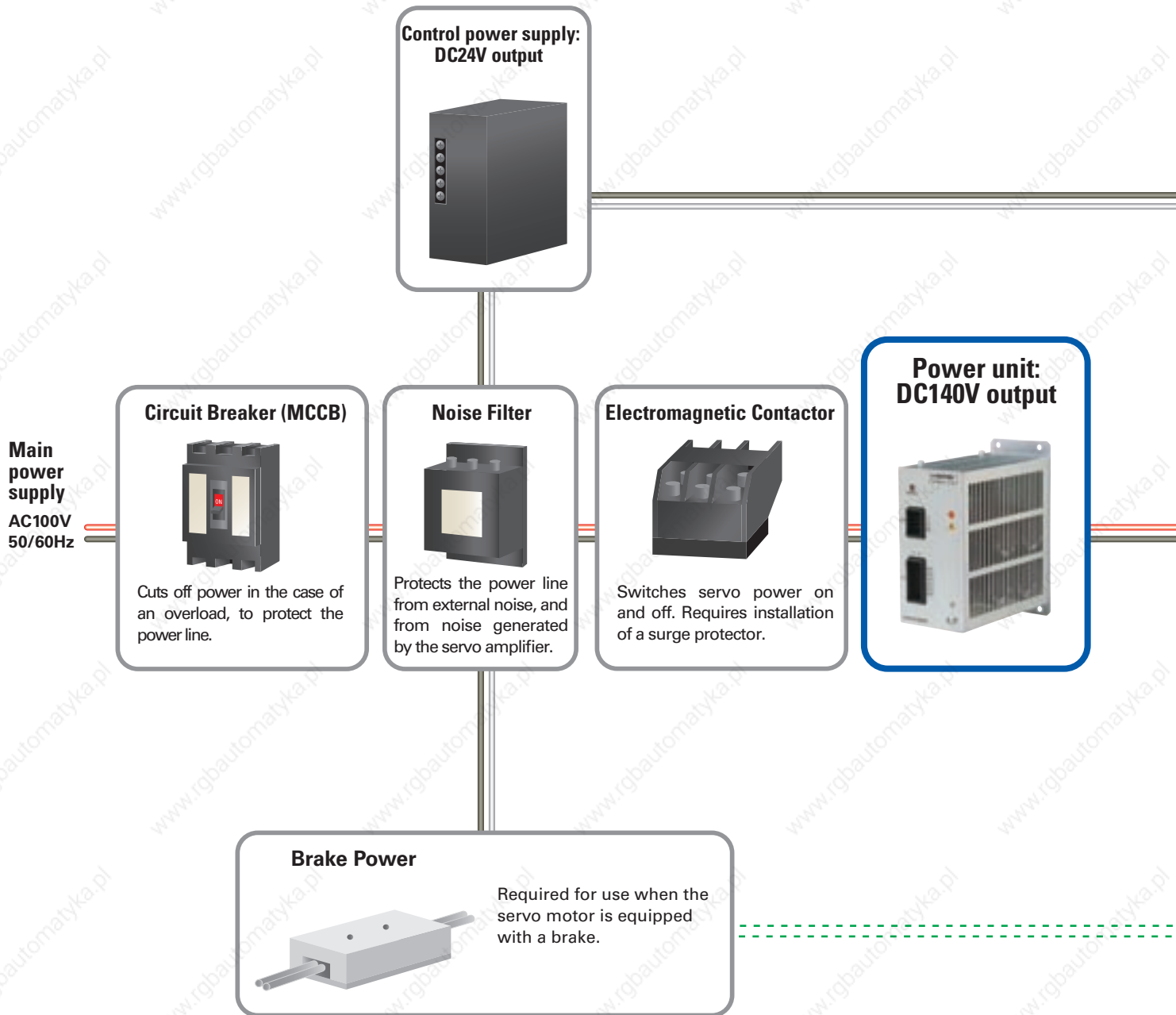

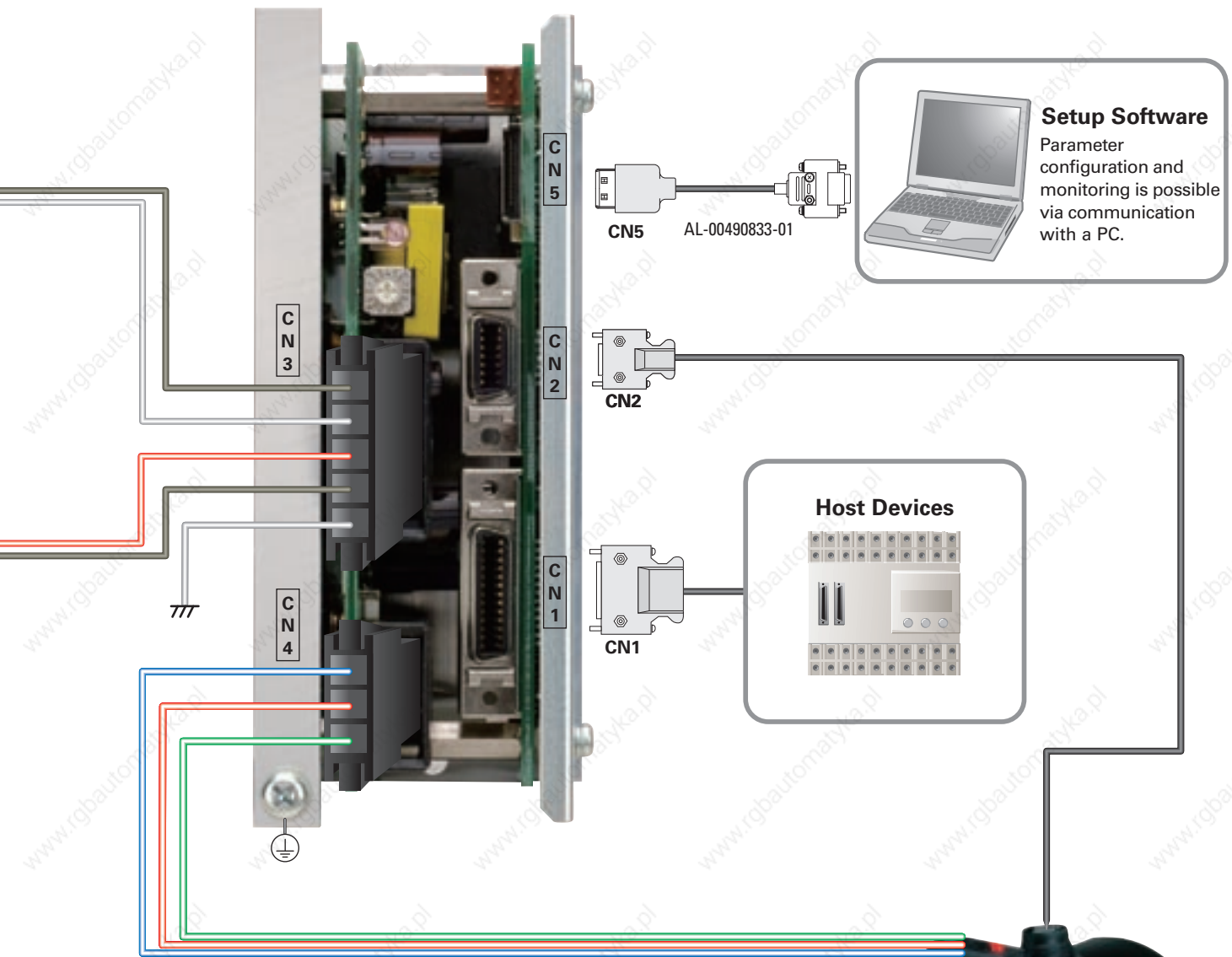

Wiring required for brake.

Setup Software
 Parameter configuration and monitoring is possible via communication with a PC.

Host Devices

- Features and Functions
- Model Number Nomenclature
- System Configuration**
- Standard Specifications
- External Wiring Diagram
- Dimensions
- Setup Software
- Optional Equipment

Specification

Servo amplifier + Servo motor

| Applicable amplifier model No. | | | | TS1B02AA | TS1A02AA |
|--|-----------|------------------|---|--|------------------------|
| Motor Model No. | | | | T402-011EL8 | T404-012EL8 |
| | Condition | Symbol | Unit (SI) | | |
| Servo amplifier Input power(Control circuit) | | | | DC24V +10, -15% | |
| Servo amplifier Input power(Main circuit) | | | | DC50V +10, -15% | DC140V +10, -15% |
| Amplifier operation temperature and humidity | | | | Temperature: 0 to 55°C Humidity: Maximum 90% (no condensation) | |
| Power capacity(Rated) | | | kVA | 0.2 | 0.2 |
| Amplifier mass | | | kg | 0.45 | |
| Rated output | ★ | P_R | W | 23 | 40 |
| Rated speed | ★ | N_R | min^{-1} | 3000 | |
| Maximum speed | ★ | N_{max} | min^{-1} | 3000 | |
| Rated torque | ★ | T_R | $\text{N} \cdot \text{m}$ | 0.061 | 0.080 |
| Continuous stall torque | ★ | T_S | $\text{N} \cdot \text{m}$ | 0.070 | 0.120 |
| Instantaneous maximum stall torque | ★ | T_{PS} | $\text{N} \cdot \text{m}$ | 0.206 | 0.319 |
| Rated armature voltage | ★ | E_R | V | 20 | 72 |
| Rated armature current | ★ | I_R | A | 1.9 | 1.0 |
| Continuous stall armature current | ★ | I_S | A | 1.9 | 0.9 |
| Instantaneous maximum stall armature current | ★ | I_P | A | 4.9 | 2.1 |
| Torque constant | ☆ | K_T | $\text{N} \cdot \text{m/A}$ | 0.047 | 0.174 |
| Voltage constant per phase | ☆ | K_E | V/kmin^{-1} | 4.9 | 18.2 |
| Phase resistance | ☆ | R_b | Ω | 3.2 | 18.6 |
| Rated power rate | ★ | O_R | kW/s | 1.2 | 2.1 |
| Electrical time constant | ☆ | t_c | ms | 0.35 | 0.35 |
| Mechanical time constant | ☆ | t_m | ms | 7.1 | 4.8 |
| Load inertia | | J_L | $\text{kg} \cdot \text{m}^2(\text{GD}^2/4)$ | 0.16×10^{-4} | 0.27×10^{-4} |
| Encoder pulse number (output circuit system) | | | P/R | 1000(Line driver) | |
| Rotor inertia (including sensor) | | J_M | $\text{kg} \cdot \text{m}^2(\text{GD}^2/4)$ | 0.055×10^{-4} | 0.092×10^{-4} |
| Motor mass (including sensor) | | | kg | 0.55 | 0.65 |
| Break-holding torque | ★ | T_B | $\text{N} \cdot \text{m}$ | — | — |
| Break excitation voltage | ☆ | V_B | V | — | — |
| Break excitation current | ☆ | I_B | A | — | — |
| Break inertia | | J_B | $\text{kg} \cdot \text{m}^2(\text{GD}^2/4)$ | — | — |
| Break mass | | | kg | — | — |
| Motor operation temperature and humidity | | | | Temperature: 0 to 40°C Humidity: Maximum 90% (no condensation) | |

- ★ mark indicates a typical value after temperature increased and saturated in the combination with the standard amplifier
 ☆ mark indicates a typical value when the winding temperature is at 25°C.

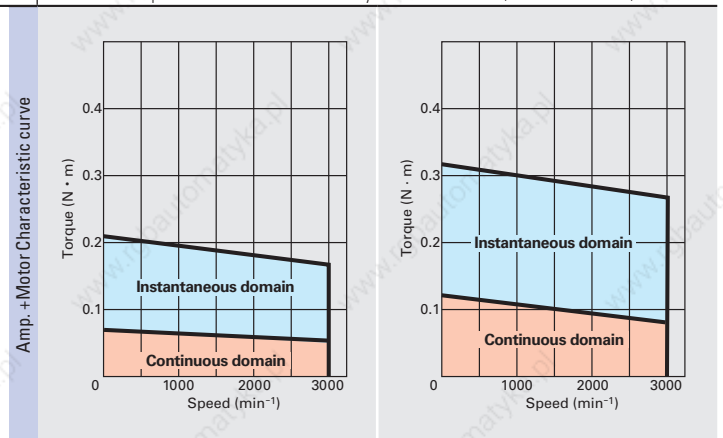

| TS1A02AA | | TS1AA2AA | |
|--|------------------------|------------------------|------------------------|
| T406-012EL8 | T506-012EL8 | T511-012EL8 | T720-012EL8 |
| DC24V +10, -15% | | | |
| DC140V +10, -15% | | | |
| Temperature: 0 to 55°C Humidity: Maximum 90% (no condensation) | | | |
| 0.3 | 0.3 | 0.4 | 0.6 |
| 0.45 | | | |
| 60 | 60 | 110 | 200 |
| 3000 | | | |
| 3000 | | | |
| 0.137 | 0.156 | 0.270 | 0.605 |
| 0.175 | 0.192 | 0.358 | 0.658 |
| 0.441 | 0.441 | 0.784 | 1.47 |
| 70 | 75 | 75 | 80 |
| 1.4 | 1.2 | 2.0 | 3.4 |
| 1.4 | 1.3 | 2.2 | 3.7 |
| 2.9 | 2.8 | 4.5 | 7.7 |
| 0.177 | 0.183 | 0.21 | 0.23 |
| 18.5 | 19.1 | 21.8 | 24.2 |
| 11.8 | 12.1 | 5.1 | 2.8 |
| 3.2 | 1.7 | 3.2 | 2.7 |
| 0.37 | 0.47 | 0.63 | 1.1 |
| 4.1 | 7.4 | 4.3 | 7.8 |
| 0.34×10^{-4} | 0.68×10^{-4} | 1.13×10^{-4} | 4.43×10^{-4} |
| 1000(Line driver) | | | |
| 0.116×10^{-4} | 0.228×10^{-4} | 0.378×10^{-4} | 1.478×10^{-4} |
| 0.75 | 0.9 | 1.2 | 2.05 |
| — | 0.29 | | 1.47 |
| — | 90 | | 90 |
| — | 0.06 | | 0.11 |
| — | 0.01×10^{-4} | | 0.09×10^{-4} |
| — | 0.26 | | 0.59 |

Temperature: 0 to 40°C Humidity: Maximum 90% (no condensation)

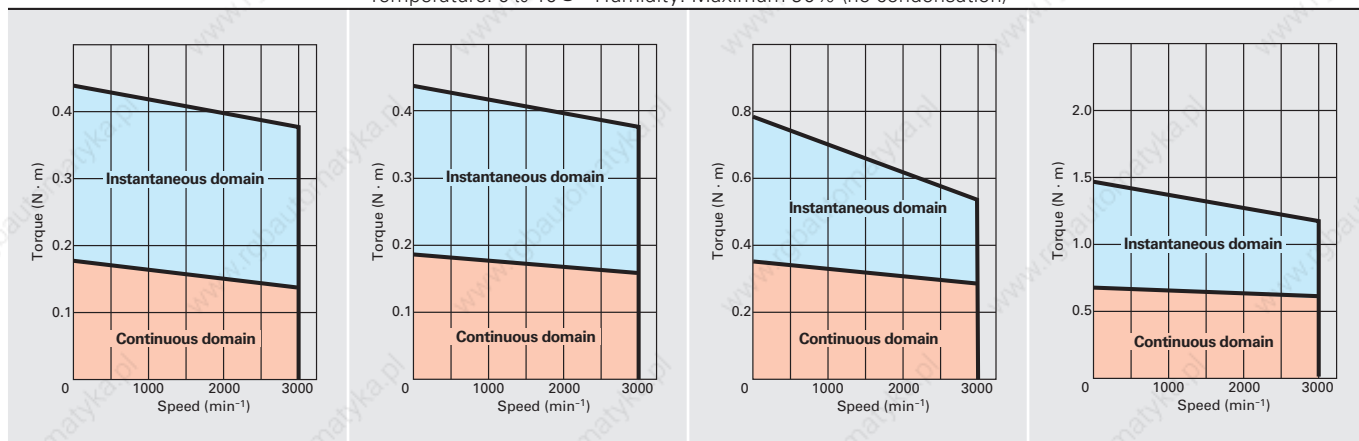

- Features and Functions
- Model Number Nomenclature
- System Configuration
- Standard Specifications
- External Wiring Diagram
- Dimensions
- Setup Software
- Optional Equipment

Specification

Servo amplifier + Servo motor

| Applicable amplifier model No. | | | | TS1AA2AA | TS1A03AA |
|--|-----------|------------|---|--|------------------------|
| Motor Model No. | | | | T730-012EL8 | T840-012EL8 |
| | Condition | Symbol | Unit (SI) | | |
| Servo amplifier Input power(Control circuit) | | | | DC24V +10, -15% | |
| Servo amplifier Input power(Main circuit) | | | | DC140V +10, -15% | |
| Amplifier operation temperature and humidity | | | | Temperature: 0 to 55°C Humidity: Maximum 90% (no condensation) | |
| Power capacity(Rated) | | | kVA | 0.9 | 1.0 |
| Amplifier mass | | | kg | 0.45 | 0.65 |
| Rated output | ★ | P_R | W | 300 | 400 |
| Rated speed | ★ | N_R | min^{-1} | 2500 | |
| Maximum speed | ★ | N_{\max} | min^{-1} | 2500 | |
| Rated torque | ★ | T_R | $\text{N} \cdot \text{m}$ | 1.00 | 1.66 |
| Continuous stall torque | ★ | T_S | $\text{N} \cdot \text{m}$ | 1.05 | 1.70 |
| Instantaneous maximum stall torque | ★ | T_{PS} | $\text{N} \cdot \text{m}$ | 2.45 | 3.72 |
| Rated armature voltage | ★ | E_R | V | 75 | 85 |
| Rated armature current | ★ | I_R | A | 5.2 | 5.8 |
| Continuous stall armature current | ★ | I_S | A | 5.5 | 6 |
| Instantaneous maximum stall armature current | ★ | I_P | A | 10.9 | 13.7 |
| Torque constant | ☆ | K_T | $\text{N} \cdot \text{m}/\text{A}$ | 0.273 | 0.31 |
| Voltage constant per phase | ☆ | K_E | $\text{V}/\text{kmin}^{-1}$ | 28.6 | 32.9 |
| Phase resistance | ☆ | R_b | Ω | 1.1 | 0.95 |
| Rated power rate | ★ | O_R | kW/s | 5.1 | 5.0 |
| Electrical time constant | ☆ | t_c | ms | 1.5 | 2.0 |
| Mechanical time constant | ☆ | t_m | ms | 4.0 | 5.2 |
| Load inertia | | J_L | $\text{kg} \cdot \text{m}^2(\text{GD}^2/4)$ | 8.12×10^{-4} | 15×10^{-4} |
| Encoder pulse number (output circuit system) | | | P/R | 1000(Line driver) | |
| Rotor inertia (including sensor) | | J_M | $\text{kg} \cdot \text{m}^2(\text{GD}^2/4)$ | 2.708×10^{-4} | 5.008×10^{-4} |
| Motor mass (including sensor) | | | kg | 2.75 | 3.65 |
| Break-holding torque | ★ | T_B | $\text{N} \cdot \text{m}$ | 1.47 | 1.96 |
| Break excitation voltage | ☆ | V_B | V | 90 | 90 |
| Break excitation current | ☆ | I_B | A | 0.11 | 0.11 |
| Break inertia | | J_B | $\text{kg} \cdot \text{m}^2(\text{GD}^2/4)$ | 0.09×10^{-4} | 0.2×10^{-4} |
| Break mass | | | kg | 0.59 | 0.79 |
| Motor operation temperature and humidity | | | | Temperature: 0 to 40°C Humidity: Maximum 90% (no condensation) | |

- ★ mark indicates a typical value after temperature increased and saturated in the combination with the standard amplifier
- ☆ mark indicates a typical value when the winding temperature is at 25°C.

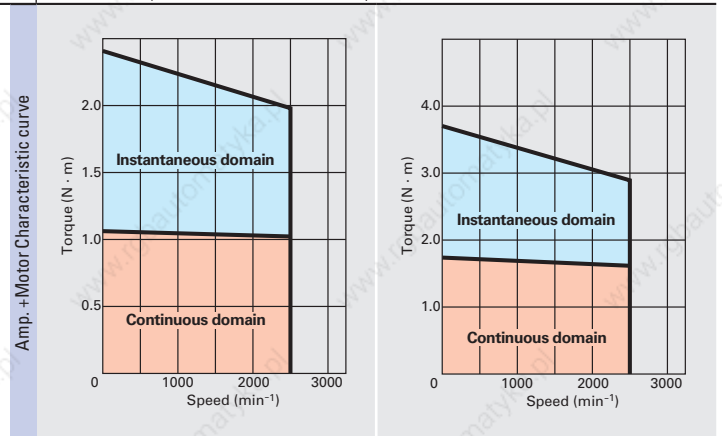

| TS1A03AA |
|------------------------|
| T850-012EL8 |
| DC24V +10, -15% |
| DC140V +10, -15% |
| The same as the left |
| 1.3 |
| 0.65 |
| 500 |
| 2500 |
| 2500 |
| 1.76 |
| 1.90 |
| 4.21 |
| 80 |
| 7.6 |
| 7.6 |
| 17.6 |
| 0.287 |
| 30 |
| 0.56 |
| 6.4 |
| 1.9 |
| 4.1 |
| 18×10^{-4} |
| 1000(Line driver) |
| 6.008×10^{-4} |
| 4.25 |
| 1.96 |
| 90 |
| 0.11 |
| 0.2×10^{-4} |
| 0.79 |
| The same as the left |

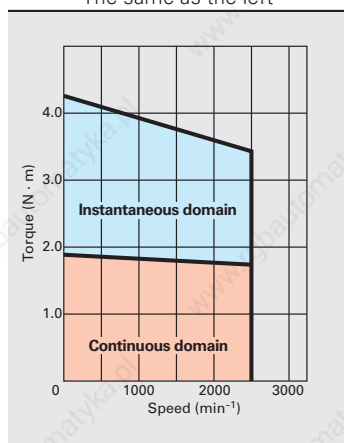

Power Unit specifications

| Applicable Power unit model No. | Unit | TS1PA05 | TS1PA10 | TS1PA15 |
|---|------|--|---------|---------|
| Power unit Input voltage | V | AC100V +10%,-15% or AC35V +10%,-15% | | |
| Power unit rated output current | A | 5 | 10 | 15 |
| Power unit operation temperature and humidity | | Temperature: 0 to 55°C Humidity: Maximum 90% (no condensation) | | |
| Power capacity(Rated) at AC100V input | KVA | 1.4 | 2.8 | 4.2 |
| Power unit weight | Kg | 0.70 | 0.75 | 0.80 |

Features and Functions

Model Number Nomenclature

System Configuration

Standard Specifications

External Wiring Diagram

Dimensions

Setup Software

Optional Equipment

Specification

Servo motor

| Model | | | | | T402-011 | T404-012 |
|------------------------------|--|----------------------------------|-----------|-------------------------------|-------------------------|-------------------------|
| | Condition | Symbol | Unit (SI) | | | |
| Motor | Rated output | ☆☆ | PR | W | 23 | 40 |
| | Rated armature voltage | ☆☆ | VR | V | 20 | 72 |
| | Rated torque | ☆☆ | TR | N·m | 0.074 | 0.13 |
| | Rated armature current | ☆☆ | IR | A | 1.9 | 1.0 |
| | Rated rotating speed | ☆☆ | NR | min ⁻¹ | 3000 | |
| | Continuous stall torque | ☆☆ | TS | N·m | 0.08 | 0.14 |
| | Instantaneous maximum torque | ☆☆ | TP(N) | N·m | 0.42 | 0.76 |
| | Stall armature current | ☆☆ | IS | A | 1.9 | 0.9 |
| | Instantaneous maximum armature current | ☆☆ | IP(N) | A | 10 | 4.7 |
| | Maximum rotating speed | | Nmax | min ⁻¹ | 5000 | |
| | Friction torque | ☆ | Tf | N·m | 0.015 | 0.019 |
| | Rated power rate | ☆☆ | QR | kW/S | 1.2 | 2.1 |
| | Instantaneous maximum angular acceleration | ☆☆ | αP | rad/s ² | 89.4×10 ³ | 90.5×10 ³ |
| | Viscous braking constant | ☆ | Fd | N·m/min ⁻¹ | 0.003×10 ⁻³ | 0.006×10 ⁻³ |
| | Torque constant | ☆ | KT | N·m/A | 0.047 | 0.174 |
| | Voltage constant | ☆ | KE | V/min ⁻¹ | 4.9×10 ⁻³ | 18.2×10 ⁻³ |
| | Rotor inertia | | JM | kg·m ² | 0.0047×10 ⁻³ | 0.0084×10 ⁻³ |
| | Armature winding resistance | ☆ | Ra | Ω | 3.2 | 18.6 |
| | Armature inductance | ☆ | Ja | mH | 1.1 | 6.6 |
| | Mechanical time constant | ☆ | tm | ms | 7.1 | 4.8 |
| | Electrical time constant | ☆ | te | ms | 0.35 | 0.35 |
| | Thermal time constant | ☆☆ | tθ | min | 15 | 20 |
| | Thermal resistance | ☆☆ | Rθ | K/W | 4.9 | 3.6 |
| | Heatup limit | ☆☆ | θ | K | 105 | |
| | Mass | | W/M | kg | 0.3 | 0.4 |
| | Tachogenerator | Coefficient of voltage generated | ☆ | KEG | V/min ⁻¹ | 3×10 ⁻³ ±10% |
| Effective (rms) ripple | | ☆ | εs | % | 2 | |
| Peak-to-peak ripple | | ☆ | εs | % | 5 | |
| Linearity | | ☆ | δL | % | 1 | |
| Armature winding resistance | | ☆ | Ri | Ω | 37 | |
| Armature inductance | | ☆ | Li | mH | 5 | |
| Minimum load resistance | | ☆ | RL | kΩ | 10 | |
| Rotor inertia | | | JTG | kg·m ² | 0.0011×10 ⁻³ | |
| Mass | | | WT | kg | 0.09 | |
| Holding brake | | Holding torque | ☆☆ | TB | N·m | — |
| | Voltage | ☆ | VB | V DC | — | |
| | Current | ☆ | IB | A | — | |
| | Resistance | ☆ | RB | Ω | — | |
| | Inertia | | JB | kg·m ² | — | |
| | Mass | | WB | kg | — | |
| Optical encoder pulse number | Open collector | | | 200 500 1000 P/R | | |
| | Line driver | | | 1000 2000 2500 5000 10000 P/R | | |
| Gear | | | | | 1/12.5 1/25 1/50 | |
| Oil seal | | | | | — | |

- Note 1) The mark * in the "Condition" column is a value that applies when the ambient temperature and armature winding temperature are 25°C. The mark * is a value that applies when the temperature has risen to the limit.
- 2) The figures in the above table apply when a smooth DC power supply is used at an ambient temperature of no more than 40°C.
- 3) The characteristics of the tachogenerator are based on the use of a test circuit illustrated below.

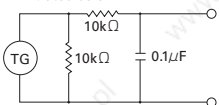

- 4) The values in the above table were measured when a specific device was mounted on an aluminum plate. T4 type, T5 type (200mm Height × 200mm width × 12mm thick), and T7 and T8 type (305mm Height × 305mm width × 12mm thick).
- 5) No encoder can be installed on a T4 type equipped with a tachogenerator.
- 6) Do not use a holding brake for quick braking.
- 7) The T404 and T406 series are compatible with products having a rated voltage ER of 24V.
- 8) The brake can be of the 24V type (optional).

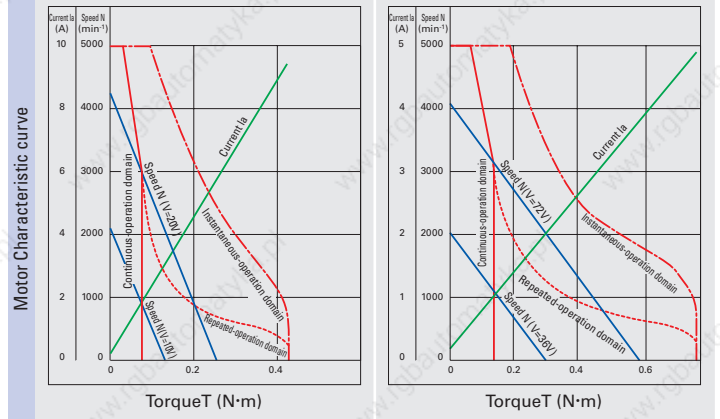

| T406-012 | T506-012 | T511-012 | T720-012 |
|-----------------------------|------------------------|---------------------------------|------------------------|
| 60 | 60 | 110 | 200 |
| 70 | | 75 | 80 |
| 0.19 | 0.19 | 0.34 | 0.64 |
| 1.4 | 1.2 | 2.0 | 3.4 |
| 3000 | | 3000 | 3000 |
| 0.20 | 0.24 | 0.42 | 0.77 |
| 1.2 | 1.8 | 3.4 | 5.4 |
| 1.4 | 1.3 | 2.2 | 3.7 |
| 7.6 | 10 | 18 | 25 |
| 5000 | | 5000 | 5000 |
| 0.020 | 0.02 | 0.022 | 0.04 |
| 3.2 | 1.7 | 3.2 | 2.7 |
| 111×10^3 | 81.8×10^3 | 91.9×10^3 | 36.7×10^3 |
| 0.008×10^{-3} | 0.009×10^{-3} | 0.013×10^{-3} | 0.020×10^{-3} |
| 0.177 | 0.183 | 0.21 | 0.23 |
| 18.5×10^{-3} | 19.1×10^{-3} | 21.8×10^{-3} | 24.2×10^{-3} |
| 0.0108×10^{-3} | 0.022×10^{-3} | 0.037×10^{-3} | 0.147×10^{-3} |
| 11.8 | 12.1 | 5.1 | 2.8 |
| 4.4 | 5.7 | 3.2 | 3.0 |
| 4.1 | 7.4 | 4.3 | 7.8 |
| 0.37 | 0.47 | 0.63 | 1.1 |
| 25 | 20 | 30 | 30 |
| 3.0 | 2.8 | 2.4 | 1.2 |
| 105 | | 105 | 105 |
| 0.5 | 0.65 | 0.95 | 1.8 |
| $3 \times 10^{-3} \pm 10\%$ | | $7 \times 10^{-3} \pm 10\%$ | |
| 2 | | 1 | |
| 5 | | 3 | |
| | | 1 | |
| 37 | | 26 | |
| 5 | | 4.1 | |
| | | 10 | |
| 0.0011×10^{-3} | | 0.012×10^{-3} | |
| 0.09 | | 0.26 | 0.35 |
| — | | 0.29 | 1.47 |
| — | | 90 | 90 |
| — | | 0.06 | 0.11 |
| — | | 1600 | 820 |
| — | | 0.001×10^{-3} | 0.009×10^{-3} |
| — | | 0.26 | 0.59 |
| | | 200 500 1000 P/R | |
| | | 1000 2000 2500 5000 10000 P/R | |
| 1/12.5 1/25 1/50 | | 1/15 1/30 1/60 1/90 | |
| — | | Installable | |

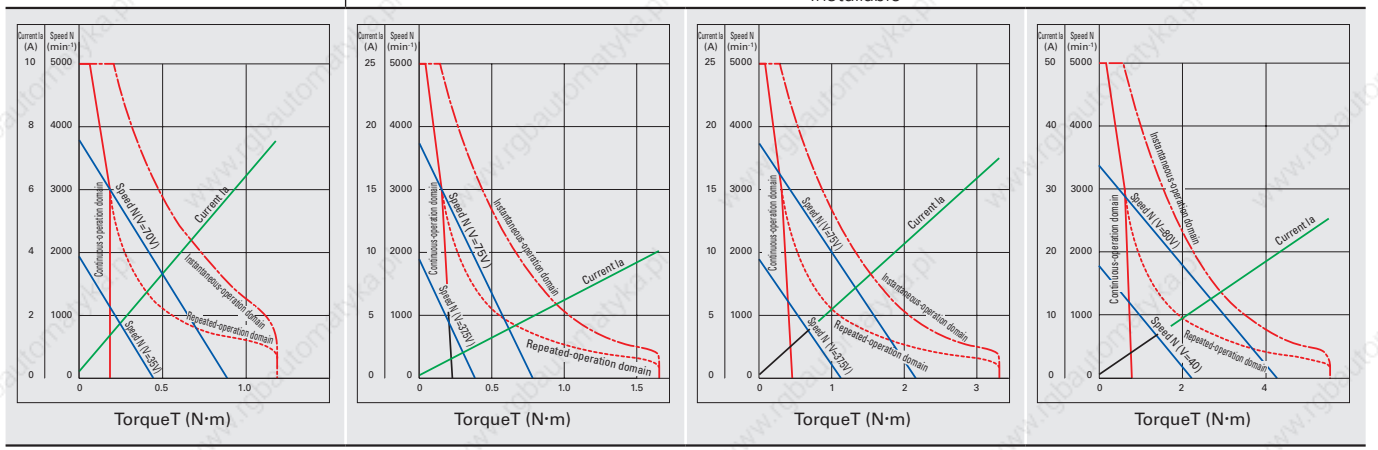

- Features and Functions
- Model Number Nomenclature
- System Configuration
- Standard Specifications
- External Wiring Diagram
- Dimensions
- Setup Software
- Optional Equipment

Specification

Servo motor

| Model | | | | | T730-012 | T840-012 |
|------------------------------|--|----------------|-----------|-----------------------|-------------------------------|------------------------|
| | Condition | Symbol | Unit (SI) | | | |
| Motor | Rated output | ☆☆ | PR | W | 300 | 400 |
| | Rated armature voltage | ☆☆ | VR | V | 75 | 85 |
| | Rated torque | ☆☆ | TR | N·m | 1.18 | 1.57 |
| | Rated armature current | ☆☆ | IR | A | 5.2 | 5.8 |
| | Rated rotating speed | ☆☆ | NR | min ⁻¹ | 2500 | |
| | Continuous stall torque | ☆☆ | TS | N·m | 1.43 | 1.70 |
| | Instantaneous maximum torque | ☆☆ | TP(N) | N·m | 9.8 | 12.0 |
| | Stall armature current | ☆☆ | IS | A | 5.5 | 6.0 |
| | Instantaneous maximum armature current | ☆☆ | IP(N) | A | 40 | 40 |
| | Maximum rotating speed | | Nmax | min ⁻¹ | 4000 | 4000 |
| | Friction torque | ☆ | Tf | N·m | 0.05 | 0.06 |
| | Rated power rate | ☆☆ | QR | kW/S | 5.1 | 5.0 |
| | Instantaneous maximum angular acceleration | ☆☆ | αP | rad/s ² | 38.4×10 ³ | 24×10 ³ |
| | Viscous braking constant | ☆ | Fd | N·m/min ⁻¹ | 0.039×10 ⁻³ | 0.045×10 ⁻³ |
| | Torque constant | ☆ | KT | N·m/A | 0.273 | 0.314 |
| | Voltage constant | ☆ | KE | V/min ⁻¹ | 28.6×10 ⁻³ | 32.9×10 ⁻³ |
| | Rotor inertia | | JM | kg·m ² | 0.270×10 ⁻³ | 0.50×10 ⁻³ |
| | Armature winding resistance | ☆ | Ra | Ω | 1.1 | 0.95 |
| | Armature inductance | ☆ | Ja | mH | 1.6 | 1.9 |
| | Mechanical time constant | ☆ | tm | ms | 4.0 | 5.2 |
| | Electrical time constant | ☆ | te | ms | 1.5 | 2.0 |
| | Thermal time constant | ☆☆ | tθ | min | 30 | 30 |
| | Thermal resistance | ☆☆ | Rθ | K/W | 1.2 | 1.1 |
| | Heatup limit | ☆☆ | θ | K | 105 | 105 |
| Mass | | W/M | kg | 2.5 | 3.4 | |
| Tachogenerator | Coefficient of voltage generated | ☆ | KEG | V/min ⁻¹ | 7×10 ⁻³ ±10% | |
| | Effective (rms) ripple | ☆ | εs | % | 1 | |
| | Peak-to-peak ripple | ☆ | εs | % | 3 | |
| | Linearity | ☆ | δL | % | 1 | |
| | Armature winding resistance | ☆ | Ri | Ω | 26 | |
| | Armature inductance | ☆ | Li | mH | 4.1 | |
| | Minimum load resistance | ☆ | RL | kΩ | 10 | |
| | Rotor inertia | | JTG | kg·m ² | 0.012×10 ⁻³ | |
| | Mass | | WT | kg | 0.35 | 0.45 |
| | Holding brake | Holding torque | ☆☆ | TB | N·m | 1.47 |
| Voltage | | ☆ | VB | V DC | 90 | 90 |
| Current | | ☆ | IB | A | 0.11 | 0.11 |
| Resistance | | ☆ | RB | Ω | 820 | 820 |
| Inertia | | | JB | kg·m ² | 0.009×10 ⁻³ | 0.02×10 ⁻³ |
| Mass | | | WB | kg | 0.59 | 0.79 |
| Optical encoder pulse number | | Open collector | | | 200 500 1000 P/R | |
| | | Line driver | | | 1000 2000 2500 5000 10000 P/R | |
| Gear | | | | | 1/15 1/30 1/60 1/90 | |
| Oil seal | | | | | Installable | |

- Note 1) The mark * in the "Condition" column is a value that applies when the ambient temperature and armature winding temperature are 25°C. The mark * is a value that applies when the temperature has risen to the limit.
 2) The figures in the above table apply when a smooth DC power supply is used at an ambient temperature of no more than 40°C.
 3) The characteristics of the tachogenerator are based on the use of a test circuit illustrated below.

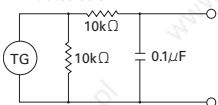

- 4) The values in the above table were measured when a specific device was mounted on an aluminum plate. T4 type, T5 type (200mm Height × 200mm width × 12mm thick), and T7 and T8 type (305mm Height × 305mm width × 12mm thick).
 5) No encoder can be installed on a T4 type equipped with a tachogenerator.
 6) Do not use a holding brake for quick braking.
 7) The T404 and T406 series are compatible with products having a rated voltage ER of 24V.
 8) The brake can be of the 24V type (optional).

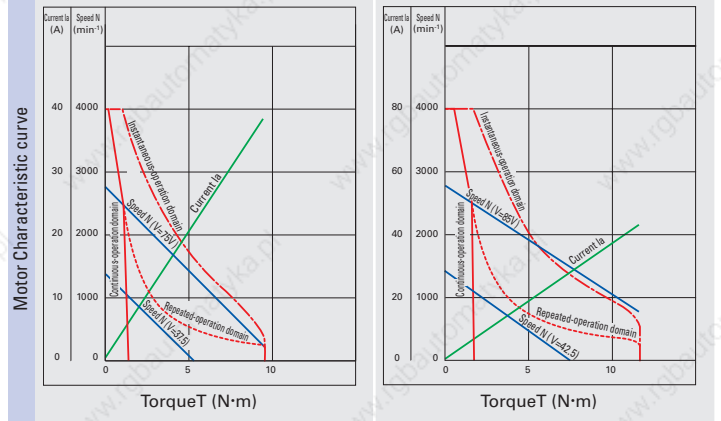

| T850-012 | |
|---------------------------------|--|
| 500 | |
| 80 | |
| 1.96 | |
| 7.6 | |
| 2500 | |
| 2.16 | |
| 16.7 | |
| 7.6 | |
| 62 | |
| 3000 | |
| 0.07 | |
| 6.4 | |
| 27.8×10^{-3} | |
| 0.058×10^{-3} | |
| 0.287 | |
| 30.0×10^{-3} | |
| 0.60×10^{-3} | |
| 0.56 | |
| 1.1 | |
| 4.1 | |
| 1.9 | |
| 40 | |
| 1.0 | |
| 105 | |
| 4.0 | |
| $7 \times 10^{-3} \pm 10\%$ | |
| 1 | |
| 3 | |
| 1 | |
| 26 | |
| 4.1 | |
| 10 | |
| 0.012×10^{-3} | |
| 0.45 | |
| 1.96 | |
| 90 | |
| 0.11 | |
| 820 | |
| 0.02×10^{-3} | |
| 0.79 | |
| 200 500 1000 P/R | |
| 1000 2000 2500 5000 10000 P/R | |

Installable

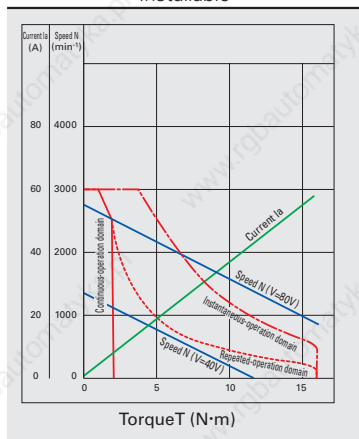

Connection method

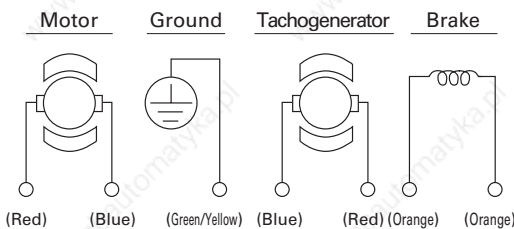

How to run the motor
Counterclockwise as viewed from the output axis when (red) + (blue) –
Tachogenerator polarity
(Red) + (blue) – in counterclockwise rotation as viewed from the output axis

Common specifications

| | |
|-----------------------|---|
| Rating | Continuous ("S1") |
| Heat resistance class | F (Type A for UL-compliance models) |
| Excitation system | Permanent magnet |
| Insulation resistance | 10MΩ or more (with a 500 VDC megger) |
| Dielectric strength | 50Hz, 1,500 VAC (600V for 24V and TG types, 1 minute (but do not perform an insulation test between the system and encoder.)) |
| Rotation method | Normal/reverse rotations possible |
| Ambient temperature | 0 to 40°C |
| Humidity | 20 to 90%RH (non-condensing) |
| Paint color | Black |
| Protection system | Fully closed (IP43) |
| Lead wire length | 1000mm |

Gear Rating

| Model No. | Motor nameplate marking | | G6 gear | GA | GB | GC |
|----------------------------|-------------------------|-----|---------|-------|-------|-------|
| | Gear model | | | G6-12 | G6-25 | G6-50 |
| Reduction ratio (nominal) | | | 1/12.5 | 1/25 | 1/50 | |
| Reduction ratio (detailed) | | | 1/12.5 | 1/25 | 1/50 | |
| Rated torque | TRG | N·m | 0.5 | 1.0 | 2.0 | |
| Instantaneous | TPG | N·m | 1.5 | 3.0 | 6.0 | |
| Mass | WG | kg | 0.4 | | | |
| Applicable motor | T4 model | | | | | |

| Model No. | Motor nameplate marking | | G8 gear | G1 | G2 | G3 | G4 |
|----------------------------|-------------------------|-----|----------|----------|----------|----------|-------|
| | Gear model | | | G8-15 | G8-30 | G8-60 | G8-90 |
| Reduction ratio (nominal) | | | 1/15 | 1/30 | 1/60 | 1/90 | |
| Reduction ratio (detailed) | | | 1/15.004 | 1/31.155 | 1/60.227 | 1/89.588 | |
| Rated torque | TRG | N·m | 1.0 | 2.0 | 4.0 | 4.0 | |
| Instantaneous | TPG | N·m | 3.0 | 6.0 | 12.0 | 12.0 | |
| Mass | WG | kg | 0.6 | | | | |
| Applicable motor | T5 model | | | | | | |

| Model No. | Motor nameplate marking | | G10 gear | G6 | G7 | G8 | G9 |
|----------------------------|-------------------------|-----|----------|----------|----------|----------|--------|
| | Gear model | | | G10-15 | G10-30 | G10-60 | G10-90 |
| Reduction ratio (nominal) | | | 1/15 | 1/30 | 1/60 | 1/90 | |
| Reduction ratio (detailed) | | | 1/15.303 | 1/30.066 | 1/60.132 | 1/90.198 | |
| Rated torque | TRG | N·m | 3.8 | 7.5 | 15.0 | 15.0 | |
| Instantaneous | TPG | N·m | 12.0 | 23.0 | 45.0 | 45.0 | |
| Mass | WG | kg | 1.5 | | | | |
| Applicable motor | T7 model | | | | | | |

Note 1) Do not apply any value exceeding the appropriate rated torque or instantaneous maximum torque.
2) Applying a value exceeding the appropriate instantaneous maximum torque causes an abnormal thrust load, perhaps resulting in affecting the encoder and other equipment.

Features and Functions

Model Number Nomenclature

System Configuration

Standard Specifications

External Wiring Diagram

Dimensions

Setup Software

Optional Equipment

Encoder specifications

Standard specifications

| Encoder type | | PP031T(Quick response specifications) | PP031 | |
|--------------------------------|-------------------|---|--|---|
| Applicable motor type | Unit | T4 ·T5 ·T7 ·T8 model | T4 ·T5 ·T7 ·T8 model | |
| Output pulse number | P/R | 1000 1024 1250 2000 2048 2500 4000 4096 5000 8000 8192 10000 | 200 500 1000 | 200 500 1000 2000 2500 |
| Rotating disk Slit number | | 500 512 625 | 200 500 1000 | 200 500 1000 2000 2500 |
| Multiplication number | | ×2 ×4 ×8 ×16 | ×1 | |
| Output circuit system | | Line driver | Open collector | Line driver |
| Channel number | | 3 | 3 | |
| Input voltage | V.DC | +5±10% | +5±10% | |
| Power demand | mA | 160max | 70max | 160max |
| Output circuit voltage | V.DC | $V_{OH}=2.4min, V_{OL}=0.5max$ at $I_o=\pm 20mA$ | +30max (When output transistor off) | $V_{OH}=2.4min, V_{OL}=0.5max$ at $I_o=\pm 20mA$ |
| Output circuit current | mA | 20max | 20max | 20max |
| Response frequency | kHz | 0 to 800 | 0 to 300 | 0 to 300 |
| Pulse duty cycle | | — | $T_1=1/2T_0\pm 1/8T_0$ | |
| Output mutual phase difference | | R1 to Rn=10 to 50% | $T_{2\text{ to }5}=1/4T_0\pm 1/8T_0$ $(T_{0max}-T_{0min})/T_0\leq 0.08$ | |
| Flutter | | — | | |
| Working temperature | °C | -10 to +85(at encoder atmosphere) | -10 to +85(at encoder atmosphere) | |
| Light emitting element | | Infrared light emitting diode | Infrared light emitting diode | |
| Light receiving element | | Photo IC | Photo diode | |
| Inertia | kg·m ² | 0.00008×10 ⁻³ | 200 P/R : 0.00003×10 ⁻³ , 500 ·1000 ·2000 ·2500 P/R : 0.00008×10 ⁻³ | |
| Weight | kg | 0.25 | 0.25 | |

External leads

| Lead color | Open collector | Line driver |
|------------|------------------|--------------------------|
| Red | +DC5V | +DC5V |
| Black | GND(0V) | GND(0V) |
| Shield | Case earth | Case earth |
| Blue | A channel output | A channel output |
| Brown | — | \bar{A} channel output |
| Green | B channel output | B channel output |
| Purple | — | \bar{B} channel output |
| White | — | C channel output |
| Yellow | C channel output | \bar{C} channel output |

Notice

- 1) Never apply shock in the thrust direction when handling the encoder.
- 2) Do not test encoder insulation resistance and dielectric strength to avoid damaging the electronic circuits.
- 3) With respect to line connection for the open collector type, among the colored lead wires, the brown, purple and white lead wires have not been connected.

Output waveform

●Open collector output

(When the encoder rotates counterclockwise viewed from the motor output shaft side)

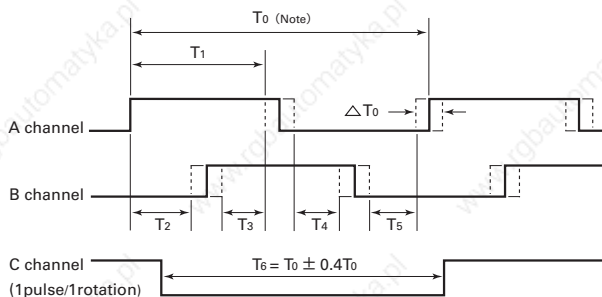

Output waveform (PP031T Quick response specifications)

●Line driver output

(when rotating in a counterclockwise direction viewed from the motor output axis)

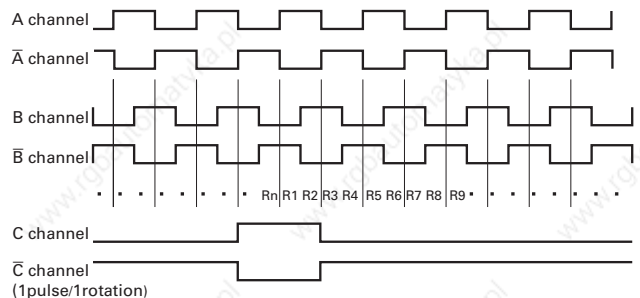

Output cross-phase difference: Rn (n=1 to pulse number x 4)
(Indicate the output cross-phase difference in percentage terms assuming 360 degrees/pulse number to be 100%.)

●Line driver output

(When the encoder rotates counterclockwise viewed from the motor output shaft side)

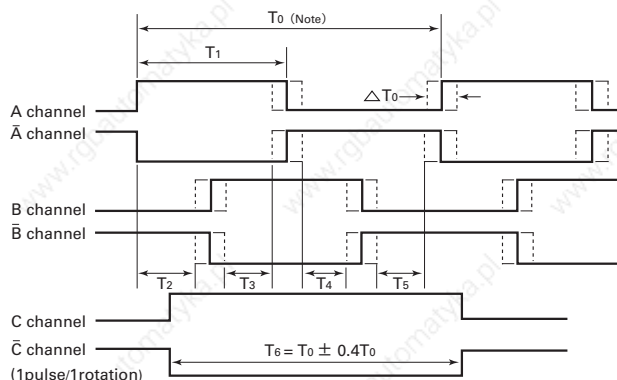

Notice) T_0^* is the average value of each cycle during one encoder rotation at a constant speed.
 T_0 : 360-degree electrical angle.

Characteristics of overload duty cycle

When repeatedly driving "SANMOTION T" under an overload as illustrated in the right-hand figure, calculate the operable time t_R on the basis of the characteristic curve of overload duty cycle.

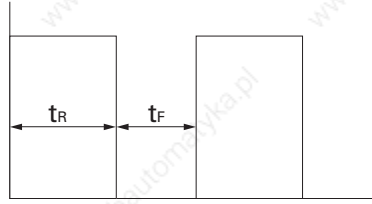

- T_S : Continuous stall torque
- T_L : Load torque
- t_R : Load time (minutes)
- t_F : Rest time (minutes)

$$\text{Load factor} = \frac{T_L}{T_S} \times 100 = \frac{\text{Armature current}}{\text{Stall armature current}} \times 100$$

$$\text{Load time factor, \%ED} = \frac{t_R}{t_R + t_F} \times 100$$

$$\text{Rest time } t_F = t_R \left(\frac{100}{\%ED} - 1 \right)$$

Typical calculations (V850-012)

Supposing that the load factor is 150% and the percentage of ED is 40%, the load time $t_R = 3$ (minutes), from the characteristic curve of overload duty cycle. Therefore,

$$\text{Rest time } t_F = t_R \left(\frac{100}{\%ED} - 1 \right) = 3 \left(\frac{100}{40} - 1 \right) = 4.5 \text{ (minutes)}$$

This means that, if you run the system at an overload of 150% with regard to the continuous stall torque for three minutes, you need a rest time of 4.5 minutes.

T402

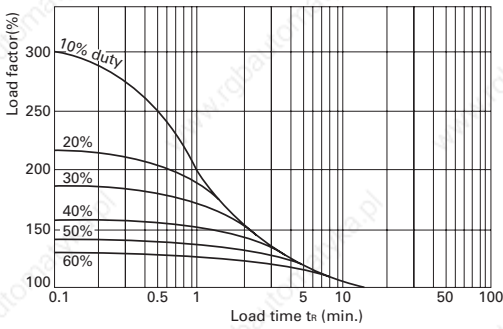

T404, T506

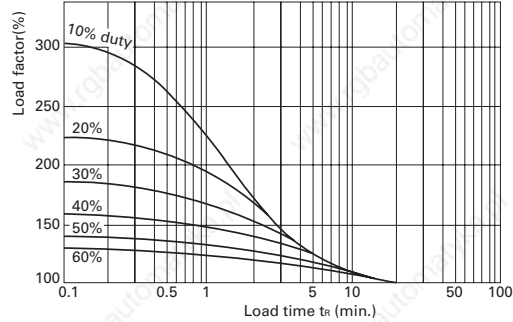

T406

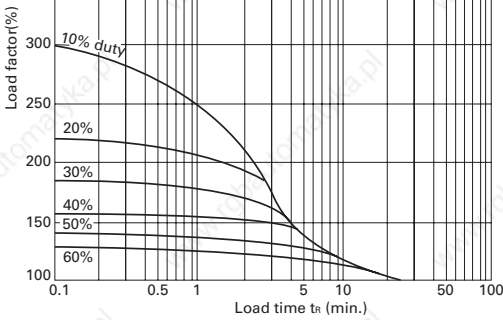

T511, T720, T730, T840

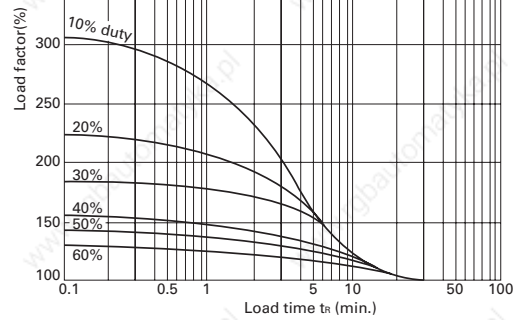

T850

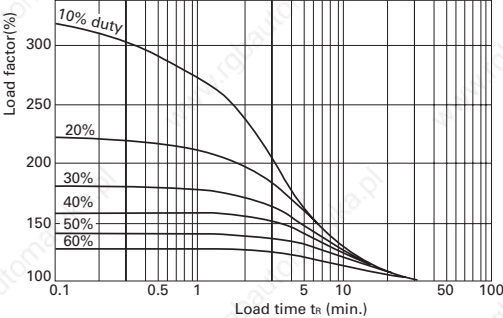

- Features and Functions
- Model Number Nomenclature
- System Configuration
- Standard Specifications
- External Wiring Diagram
- Dimensions
- Setup Software
- Optional Equipment

External Wiring Diagram

Position command Type

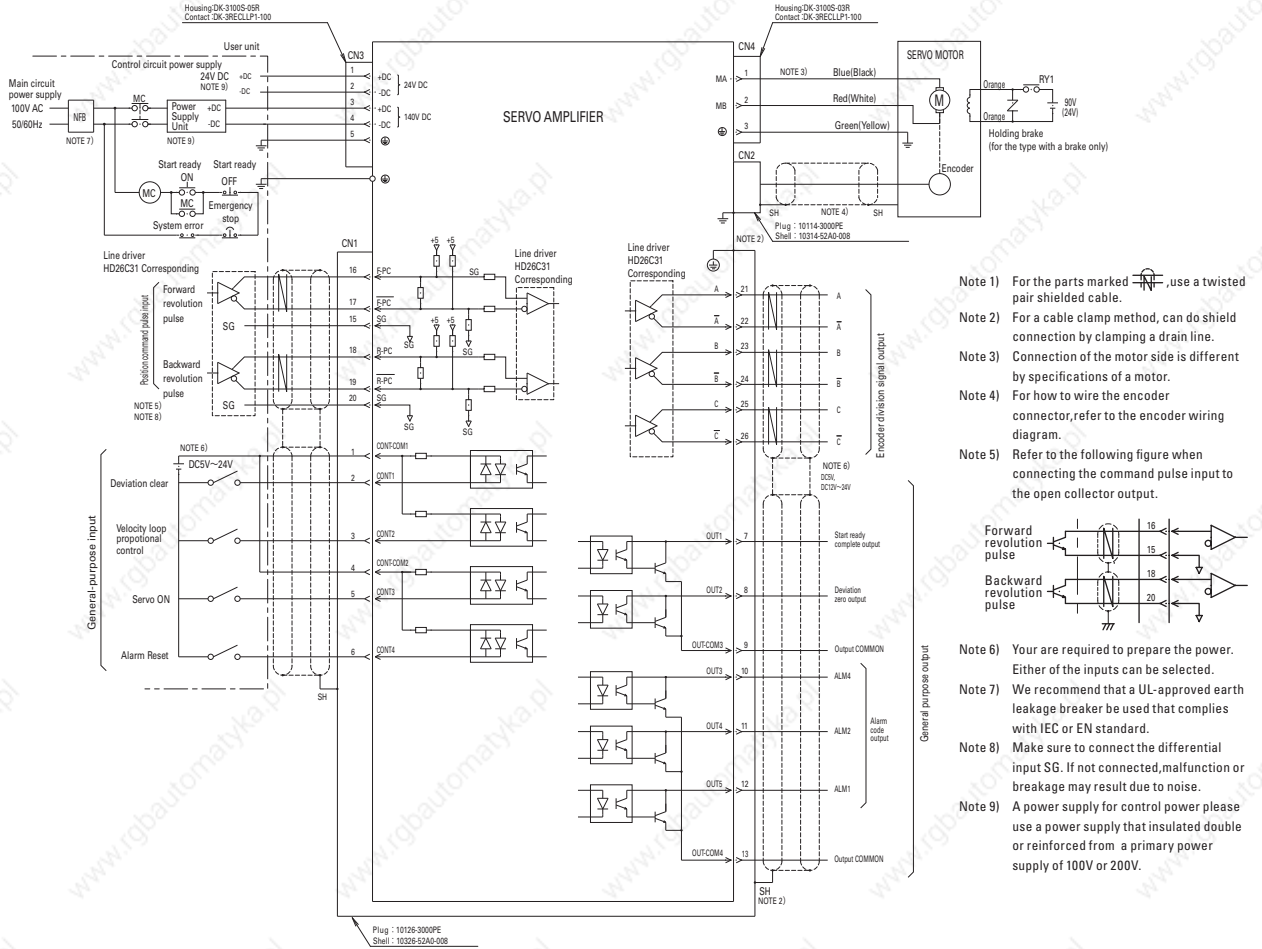

Velocity command/Torque command Type

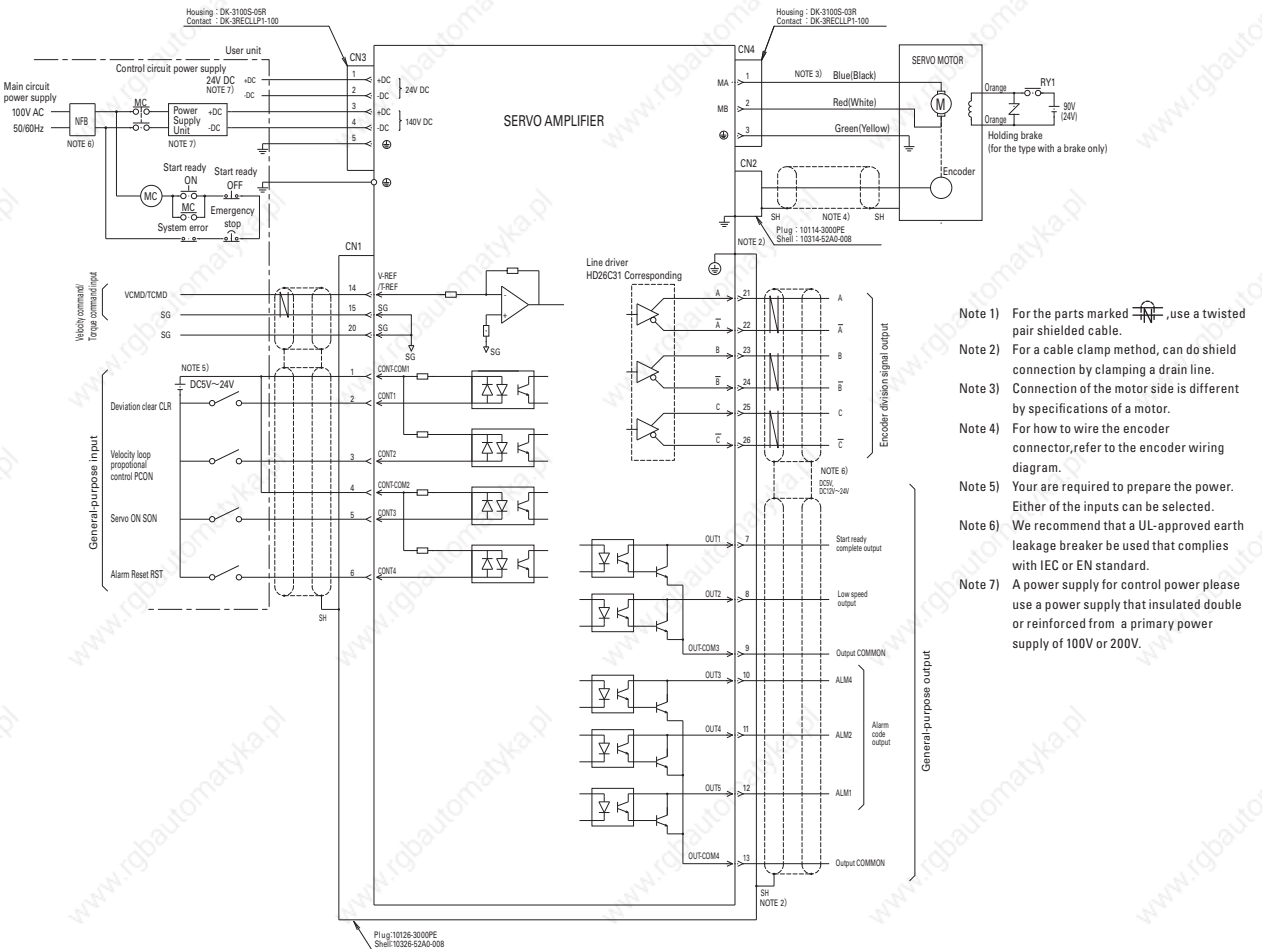

Power Unit / Encoder / Tacometer generator Wiring Diagram

Power Unit

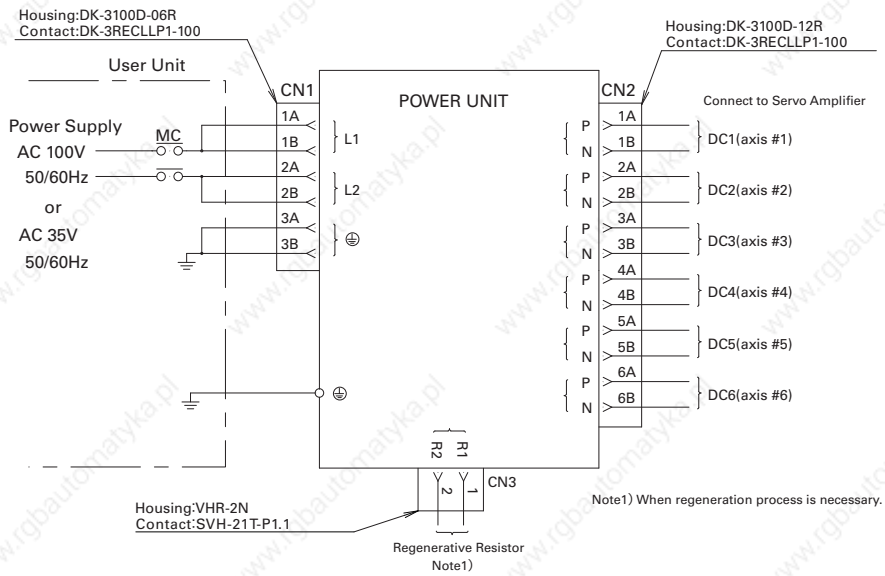

Encoder

Incremental encoder Lead wire type

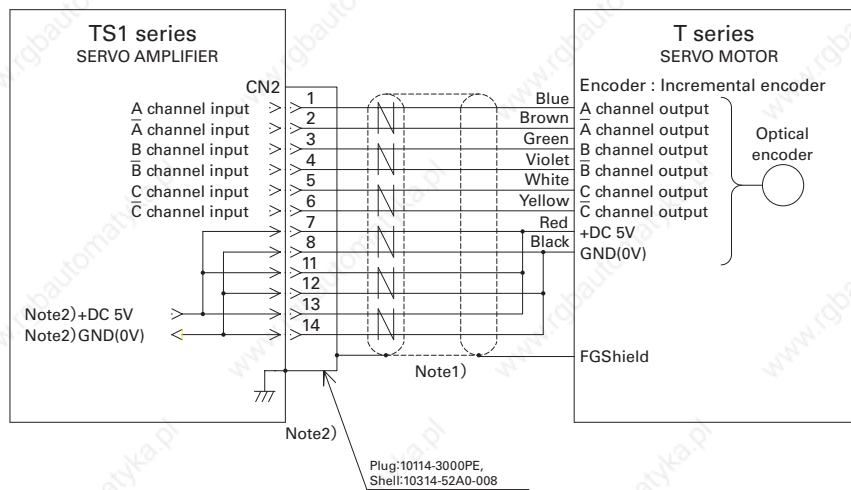

Note 1) For the parts marked , use a twisted pair shielded cable.

Note 2) The encoder power connection differs depending on the cable length. Refer to the following table.

| Encoder cable length | 5m or less | 10m or less | 20m or less |
|----------------------|--|--|-------------------------------|
| +DC 5V wiring | 13-pin connection (7 and 11 pins need not be connected) | 11- and 13-pin connection (7 pin need not be connected) | 7-, 11- and 13-pin connection |
| GND (0V) wiring | 14-pin connection (6 and 12 pins need not be connected) | 12- and 14-pin connection (8 pin need not be connected) | 8-, 12- and 14-pin connection |

Tacometer generator

Tacometer generator

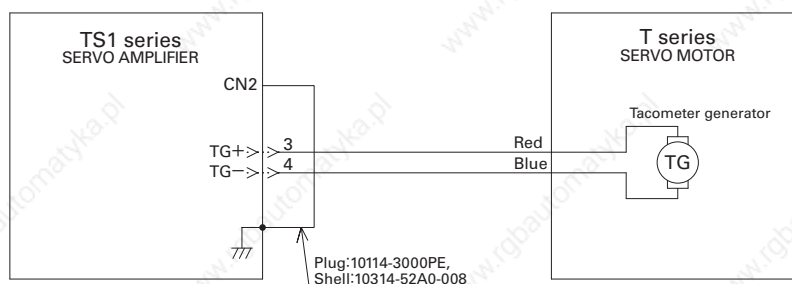

Features and Functions

Model Number Nomenclature

System Configuration

Standard Specifications

External Wiring Diagram

Dimensions

Setup Software

Optional Equipment

Servo Motor dimensions

Servo motors

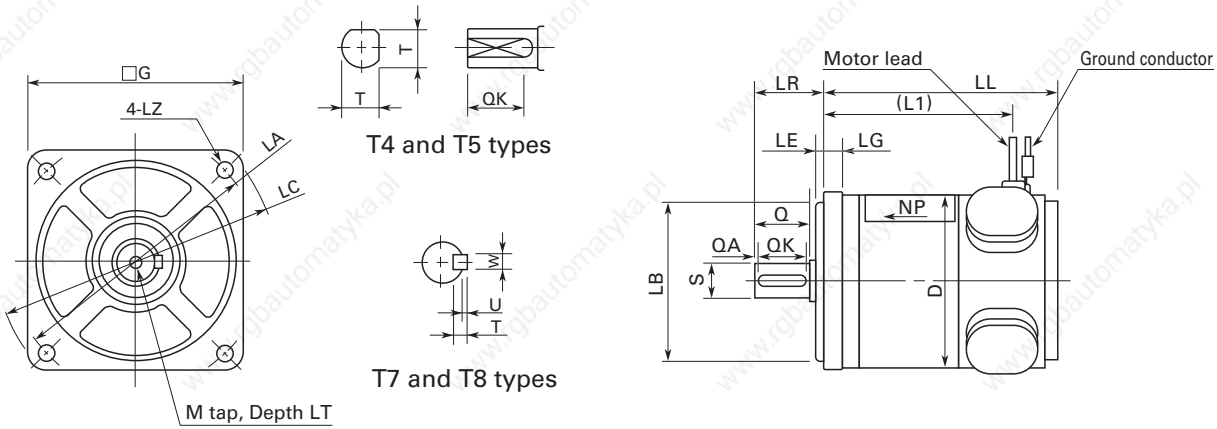

Unit : mm

| Model | LL | LG | L1 | LA | LB | LE | LC | G | LZ | LR | D | S | Q | QA | QK | W | T | U | M | LT |
|-------|-------|----|-----|-----------|-----------------------|-----|-----|----|-----|----------|------|-----------------------|----|----|----|-----------------|---|---|----|----|
| T402 | 55 | 5 | 42 | 48 ± 0.2 | 34-0.025 ⁰ | 2 | 56 | 42 | 3.5 | 24 ± 0.5 | 41 | 7-0.009 ⁰ | 20 | — | 15 | w/ 2 slots, 6.5 | | | — | — |
| T404 | 69 | | 55 | | | | | | | | | | | | | | | | | |
| T406 | 82 | | 68 | | | | | | | | | | | | | | | | | |
| T506 | 81 | 5 | 67 | 60 ± 0.3 | 50-0.025 ⁰ | 2.5 | 69 | 54 | 4.5 | 24 ± 0.5 | 51 | 7-0.009 ⁰ | 20 | — | 15 | w/ 2 slots, 6.5 | | | — | — |
| T511 | 101 | | 87 | | | | | | | | | | | | | | | | | |
| T720 | 100.5 | 8 | 83 | 90 ± 0.3 | 70-0.030 ⁰ | 3 | 100 | 76 | 5.5 | 30 ± 0.8 | 76 | 14-0.011 ⁰ | 25 | 2 | 20 | 5 | 5 | 2 | M5 | 8 |
| T730 | 124.5 | | 107 | | | | | | | | | | | | | | | | | |
| T840 | 134 | 8 | 113 | 100 ± 0.3 | 80-0.030 ⁰ | 3 | 112 | 88 | 6.6 | 35 ± 0.8 | 87.5 | 16-0.011 ⁰ | 30 | 2 | 25 | 5 | 5 | 2 | M6 | 10 |
| T850 | 149 | | 128 | | | | | | | | | | | | | | | | | |

Encoder-equipped servo motors

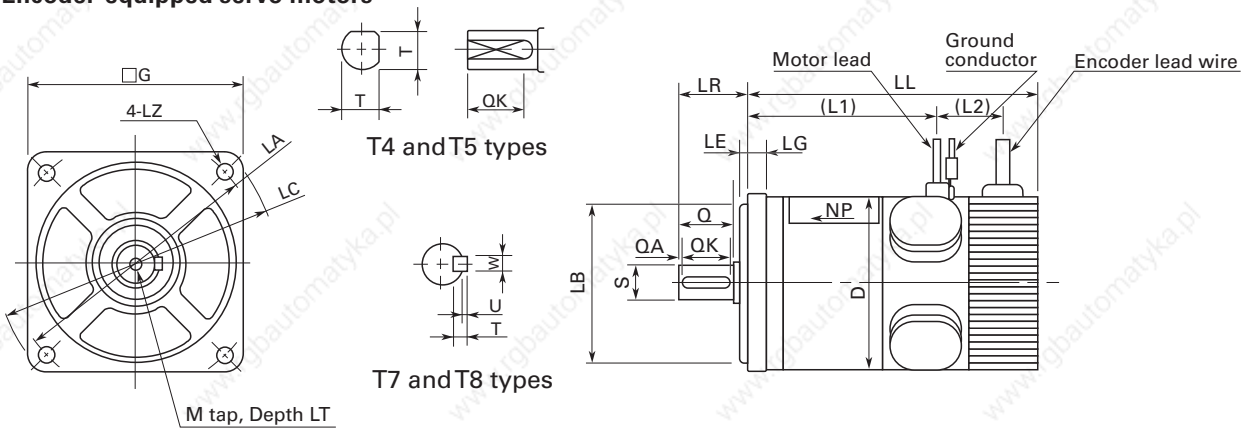

Unit : mm

| Model | LL | LG | L1 | L2 | LA | LB | LE | LC | G | LZ | LR | D | S | Q | QA | QK | W | T | U | M | LT |
|-------|-------|----|-----|----|-----------|-----------------------|-----|-----|----|-----|----------|------|-----------------------|----|----|----|-----------------|---|---|----|----|
| T402 | 83 | 5 | 42 | 18 | 48 ± 0.2 | 34-0.025 ⁰ | 2 | 56 | 42 | 3.5 | 24 ± 0.5 | 41 | 7-0.009 ⁰ | 20 | — | 15 | w/ 2 slots, 6.5 | | | — | — |
| T404 | 96 | | 55 | | | | | | | | | | | | | | | | | | |
| T406 | 109 | | 68 | | | | | | | | | | | | | | | | | | |
| T506 | 110.5 | 5 | 67 | 22 | 60 ± 0.3 | 50-0.025 ⁰ | 2.5 | 69 | 54 | 4.5 | 24 ± 0.5 | 51 | 7-0.009 ⁰ | 20 | — | 15 | w/ 2 slots, 6.5 | | | — | — |
| T511 | 130.5 | | 87 | | | | | | | | | | | | | | | | | | |
| T720 | 134.5 | 8 | 83 | 36 | 90 ± 0.3 | 70-0.030 ⁰ | 3 | 100 | 76 | 5.5 | 30 ± 0.8 | 76 | 14-0.011 ⁰ | 25 | 2 | 20 | 5 | 5 | 2 | M5 | 8 |
| T730 | 159 | | 107 | | | | | | | | | | | | | | | | | | |
| T840 | 166 | 8 | 113 | 38 | 100 ± 0.3 | 80-0.030 ⁰ | 3 | 112 | 88 | 6.6 | 35 ± 0.8 | 87.5 | 16-0.011 ⁰ | 30 | 2 | 25 | 5 | 5 | 2 | M6 | 10 |
| T850 | 181 | | 128 | | | | | | | | | | | | | | | | | | |

Tachometer generator-equipped servo motors

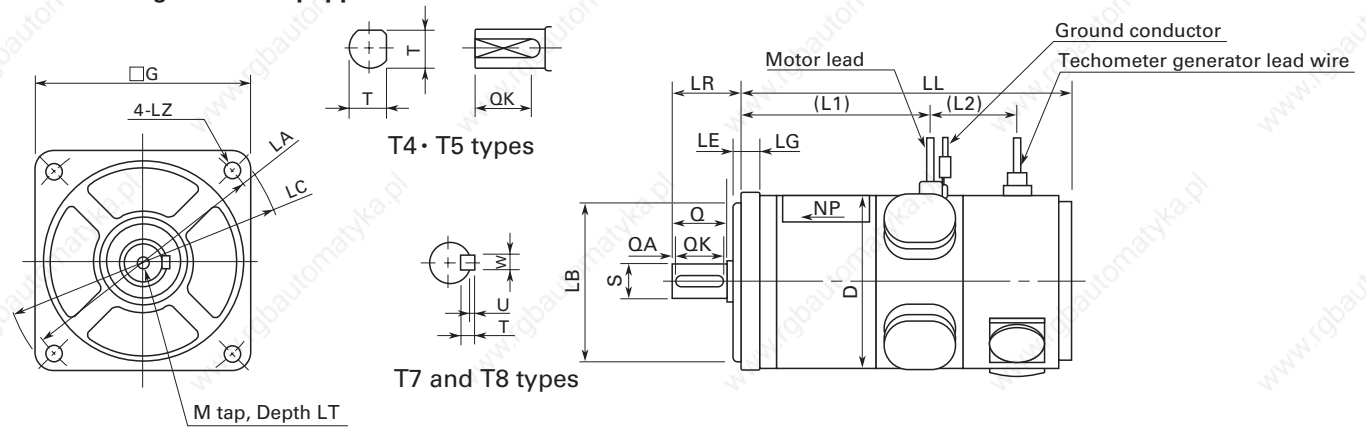

Unit : mm

| Model | LL | LG | L1 | L2 | LA | LB | LE | LC | G | LZ | LR | D | S | Q | QA | QK | W | T | U | M | LT |
|-------|-------|----|-----|----|-----------|---------------|-----|-----|----|-----|----------|------|---------------|----|----|----|-----------------|---|---|----|----|
| T402 | 87.5 | 5 | 42 | 18 | 48 ± 0.2 | 0 34-0.025 | 2 | 56 | 42 | 3.5 | 24 ± 0.5 | 41 | 0 7-0.009 | 20 | — | 15 | w/ 2 slots, 6.5 | | | — | — |
| T404 | 98 | | 55 | | | | | | | | | | | | | | | | | | |
| T406 | 111 | | 68 | | | | | | | | | | | | | | | | | | |
| T506 | 124.5 | 5 | 67 | 22 | 60 ± 0.3 | 0 50-0.025 | 2.5 | 69 | 54 | 4.5 | 24 ± 0.5 | 51 | 0 7-0.009 | 20 | — | 15 | w/ 2 slots, 6.5 | | | — | — |
| T511 | 144.5 | | 87 | | | | | | | | | | | | | | | | | | |
| T720 | 148.5 | 8 | 83 | 36 | 90 ± 0.3 | 0 70-0.030 | 3 | 100 | 76 | 5.5 | 30 ± 0.8 | 76 | 0 14-0.011 | 25 | 2 | 20 | 5 | 5 | 2 | M5 | 8 |
| T730 | 172.5 | | 107 | | | | | | | | | | | | | | | | | | |
| T840 | 183 | 8 | 113 | 38 | 100 ± 0.3 | 0 80-0.030 | 3 | 112 | 88 | 6.6 | 35 ± 0.8 | 87.5 | 0 16-0.011 | 30 | 2 | 25 | 5 | 5 | 2 | M6 | 10 |
| T850 | 198 | | 128 | | | | | | | | | | | | | | | | | | |

Brake-equipped servo motors

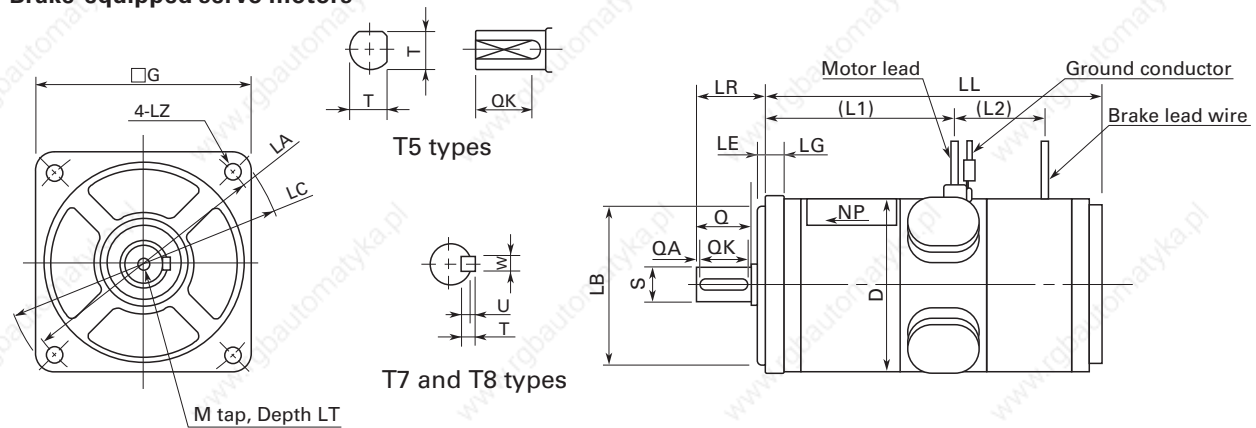

Unit : mm

| Model | LL | LG | L1 | L2 | LA | LB | LE | LC | G | LZ | LR | D | S | Q | QA | QK | W | T | U | M | LT |
|-------|-------|----|-----|----|-----------|---------------|-----|-----|----|-----|----------|------|---------------|----|----|----|-----------------|---|---|----|----|
| T506 | 118 | 5 | 67 | 36 | 60 ± 0.3 | 0 50-0.025 | 2.5 | 69 | 54 | 4.5 | 24 ± 0.5 | 51 | 0 7-0.009 | 20 | — | 15 | w/ 2 slots, 6.5 | | | — | — |
| T511 | 144.5 | | 87 | | | | | | | | | | | | | | | | | | |
| T720 | 138.5 | 8 | 83 | 40 | 90 ± 0.3 | 0 70-0.030 | 3 | 100 | 76 | 5.5 | 30 ± 0.8 | 76 | 0 14-0.011 | 25 | 2 | 20 | 5 | 5 | 2 | M5 | 8 |
| T730 | 162.5 | | 107 | | | | | | | | | | | | | | | | | | |
| T840 | 169.5 | 8 | 113 | 40 | 100 ± 0.3 | 0 80-0.030 | 3 | 112 | 88 | 6.6 | 35 ± 0.8 | 87.5 | 0 16-0.011 | 30 | 2 | 25 | 5 | 5 | 2 | M6 | 10 |
| T850 | 184.5 | | 128 | | | | | | | | | | | | | | | | | | |

Features and Functions

Model Number Nomenclature

System Configuration

Standard Specifications

External Wiring Diagram

Dimensions

Setup Software

Optional Equipment

Servo Motor dimensions

Encoder brake-equipped servo motors

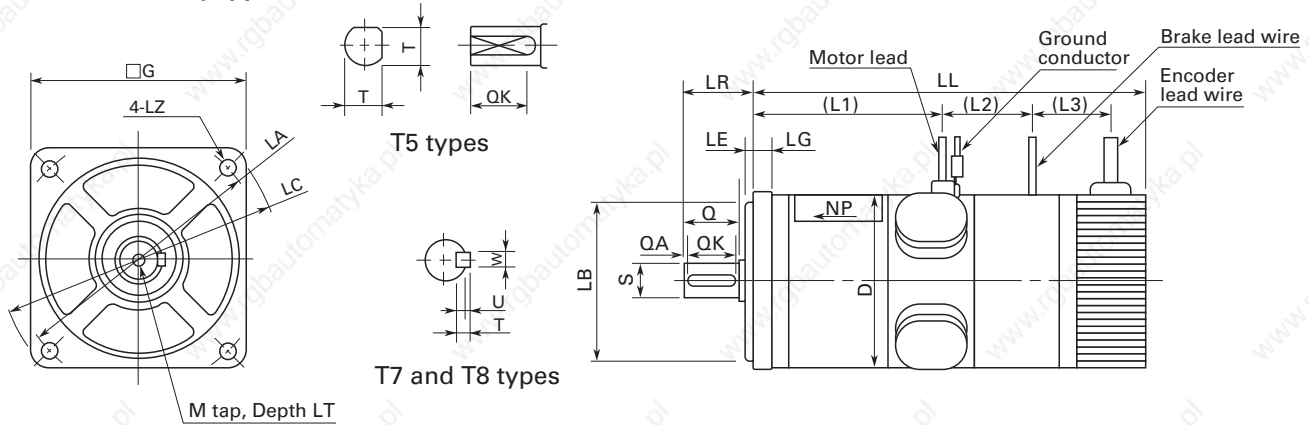

Unit : mm

| Model | LL | LG | L1 | L2 | L3 | LA | LB | LE | LC | G | LZ | LR | D | S | Q | QA | QK | W | T | U | M | LT |
|-------|-------|----|-----|----|----|-----------|---------------|-----|-----|----|-----|----------|------|---------------|----|----|----|-----------------|---|---|----|----|
| T506 | 147 | 5 | 67 | 36 | 22 | 60 ± 0.3 | 0 50-0.025 | 2.5 | 69 | 54 | 4.5 | 24 ± 0.5 | 51 | 0 7-0.009 | 20 | — | 15 | w/ 2 slots, 6.5 | | | — | — |
| T511 | 167 | | 87 | — | — | — | — | — | — | — | — | — | — | — | — | — | — | — | — | — | — | — |
| T720 | 172.5 | 8 | 83 | 38 | 35 | 90 ± 0.3 | 0 70-0.030 | 3 | 100 | 76 | 5.5 | 30 ± 0.8 | 76 | 0 14-0.011 | 25 | 2 | 20 | 5 | 5 | 2 | M5 | 8 |
| T730 | 196.5 | | 107 | — | — | — | — | — | — | — | — | — | — | — | — | — | — | — | — | — | — | — |
| T840 | 203 | 8 | 113 | 40 | 35 | 100 ± 0.3 | 0 80-0.030 | 3 | 112 | 88 | 6.6 | 35 ± 0.8 | 87.5 | 0 16-0.011 | 30 | 2 | 25 | 5 | 5 | 2 | M6 | 8 |
| T850 | 218 | | 128 | — | — | — | — | — | — | — | — | — | — | — | — | — | — | — | — | — | — | — |

Tachometer generator brake-equipped servo motors

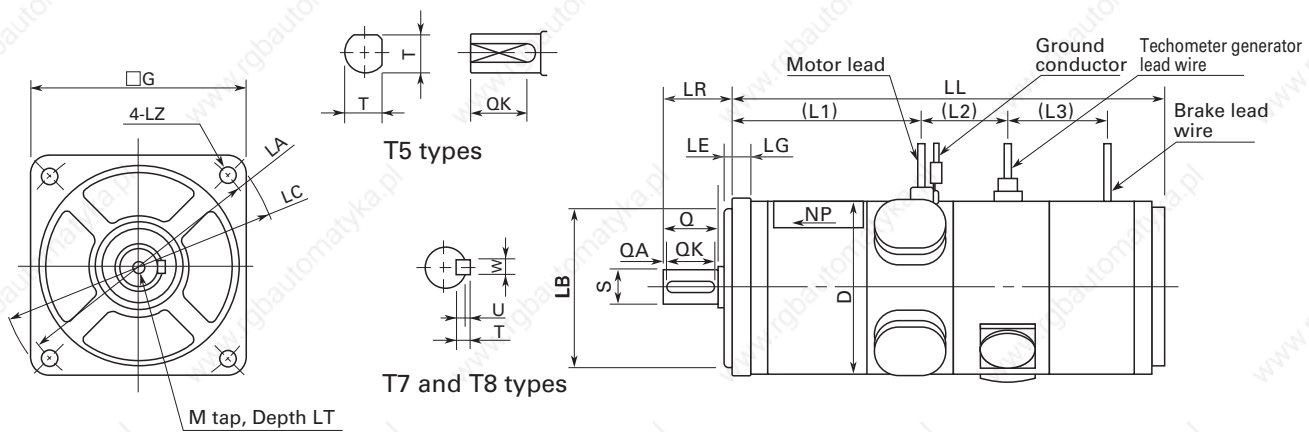

Unit : mm

| Model | LL | LG | L1 | L2 | L3 | LA | LB | LE | LC | G | LZ | LR | D | S | Q | QA | QK | W | T | U | M | LT |
|-------|-------|----|-----|----|----|-----------|---------------|-----|-----|----|-----|----------|------|---------------|----|----|----|-----------------|---|---|----|----|
| T506 | 161 | 5 | 67 | 38 | 42 | 60 ± 0.3 | 0 50-0.025 | 2.5 | 69 | 54 | 4.5 | 24 ± 0.5 | 51 | 0 7-0.009 | 20 | — | 15 | w/ 2 slots, 6.5 | | | — | — |
| T511 | 181 | | 87 | — | — | — | — | — | — | — | — | — | — | — | — | — | — | — | — | — | — | — |
| T720 | 186.5 | 8 | 83 | 40 | 44 | 90 ± 0.3 | 0 70-0.030 | 3 | 100 | 76 | 5.5 | 30 ± 0.8 | 76 | 0 14-0.011 | 25 | 2 | 20 | 5 | 5 | 2 | M5 | 8 |
| T730 | 210.5 | | 107 | — | — | — | — | — | — | — | — | — | — | — | — | — | — | — | — | — | — | — |
| T840 | 219.5 | 8 | 113 | 38 | 44 | 100 ± 0.3 | 0 80-0.030 | 3 | 112 | 88 | 6.6 | 35 ± 0.8 | 87.5 | 0 16-0.011 | 30 | 2 | 25 | 5 | 5 | 2 | M6 | 8 |
| T850 | 234.5 | | 128 | — | — | — | — | — | — | — | — | — | — | — | — | — | — | — | — | — | — | — |

Encoder tachometer generator-equipped servo motors

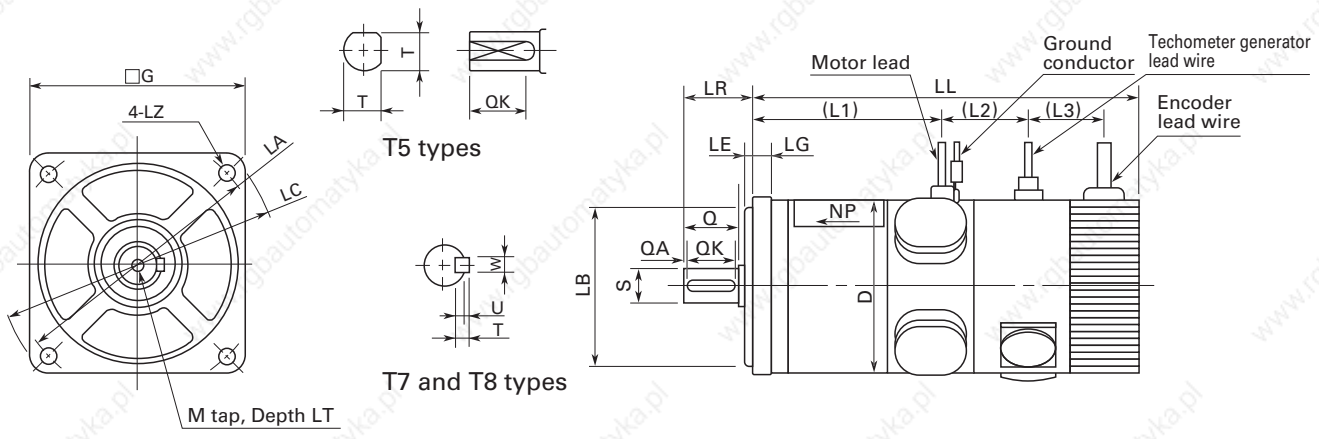

Unit : mm

| Model | LL | LG | L1 | L2 | L3 | LA | LB | LE | LC | G | LZ | LR | D | S | Q | QA | QK | W | T | U | M | LT |
|-------|-------|----|-----|----|----|-----------|----|-----|-----|----|-----|----------|------|---|----|----|----|-----------------|---|---|----|----|
| T506 | 153.5 | 5 | 67 | 38 | 27 | 60 ± 0.3 | 0 | 2.5 | 69 | 54 | 4.5 | 24 ± 0.5 | 51 | 0 | 20 | — | 15 | w/ 2 slots, 6.5 | | | — | — |
| T511 | 173.5 | | 87 | | | | | | | | | | | | | | | | | | | |
| T720 | 182 | 8 | 83 | 38 | 40 | 90 ± 0.3 | 0 | 3 | 100 | 76 | 5.5 | 30 ± 0.8 | 76 | 0 | 25 | 2 | 20 | 5 | 5 | 2 | M5 | 8 |
| T730 | 206 | | 107 | | | | | | | | | | | | | | | | | | | |
| T840 | 216 | 8 | 113 | 38 | 42 | 100 ± 0.3 | 0 | 3 | 112 | 88 | 6.6 | 35 ± 0.8 | 87.5 | 0 | 30 | 2 | 25 | 5 | 5 | 2 | M6 | 8 |
| T850 | 223.5 | | 128 | | | | | | | | | | | | | | | | | | | |

Encoder tachometer generator brake-equipped servo motors

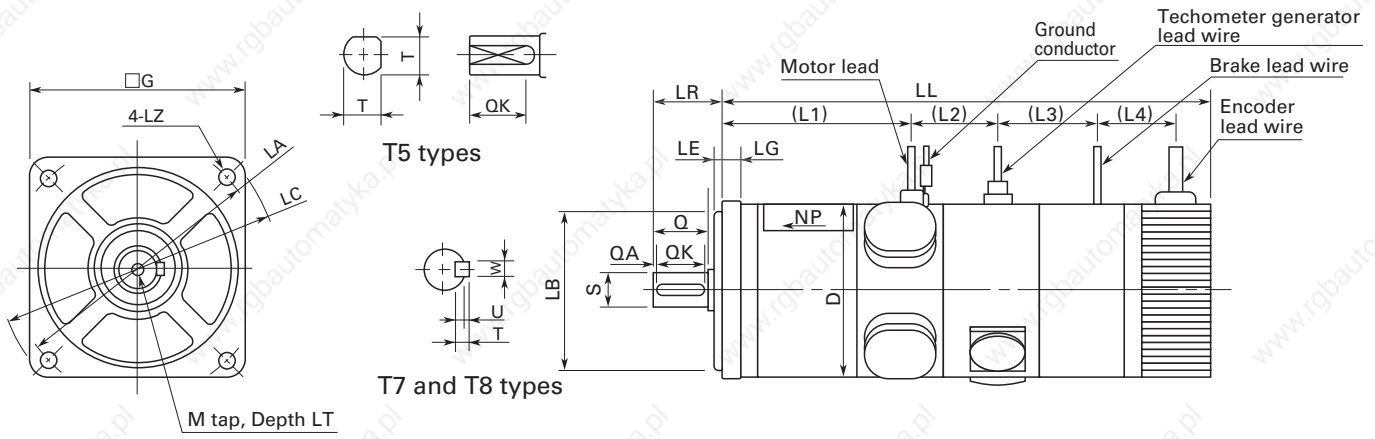

Unit : mm

| Model | LL | LG | L1 | L2 | L3 | L4 | LA | LB | LE | LC | G | LZ | LR | D | S | Q | QA | QK | W | T | U | M | LT |
|-------|-------|----|-----|----|----|----|-----------|----|-----|-----|----|-----|----------|------|---|----|----|----|-----------------|---|---|----|----|
| T506 | 190 | 5 | 67 | 38 | 42 | 22 | 60 ± 0.3 | 0 | 2.5 | 69 | 54 | 4.5 | 24 ± 0.5 | 51 | 0 | 20 | — | 15 | w/ 2 slots, 6.5 | | | — | — |
| T511 | 210 | | 87 | | | | | | | | | | | | | | | | | | | | |
| T720 | 220 | 8 | 83 | 38 | 44 | 35 | 90 ± 0.3 | 0 | 3 | 100 | 76 | 5.5 | 30 ± 0.8 | 76 | 0 | 25 | 2 | 20 | 5 | 5 | 2 | M5 | 8 |
| T730 | 246 | | 107 | | | | | | | | | | | | | | | | | | | | |
| T840 | 253.5 | 8 | 113 | 38 | 44 | 35 | 100 ± 0.3 | 0 | 3 | 112 | 88 | 6.6 | 35 ± 0.8 | 87.5 | 0 | 30 | 2 | 25 | 5 | 5 | 2 | M6 | 8 |
| T850 | 268.5 | | 128 | | | | | | | | | | | | | | | | | | | | |

- Features and Functions
- Model Number Nomenclature
- System Configuration
- Standard Specifications
- External Wiring Diagram
- Dimensions
- Setup Software
- Optional Equipment

Gear dimensions

Dimensions of a typical gear for T4

Unit : mm

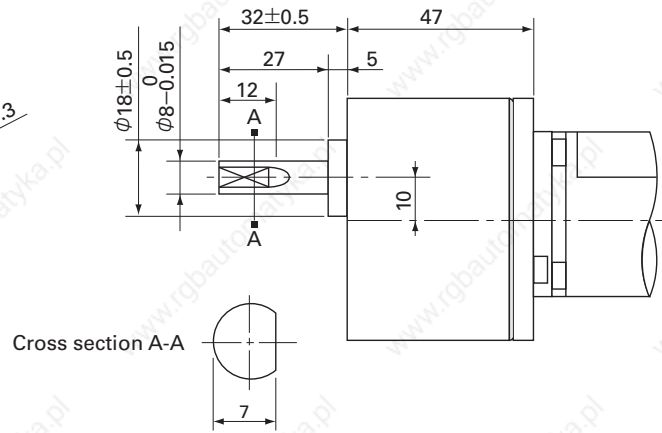
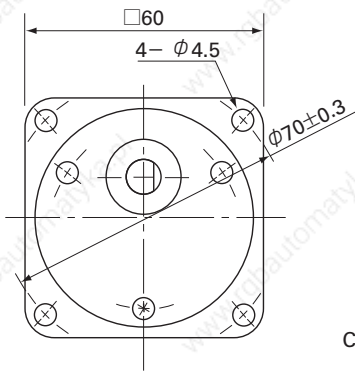

Dimensions of a typical gear for T5

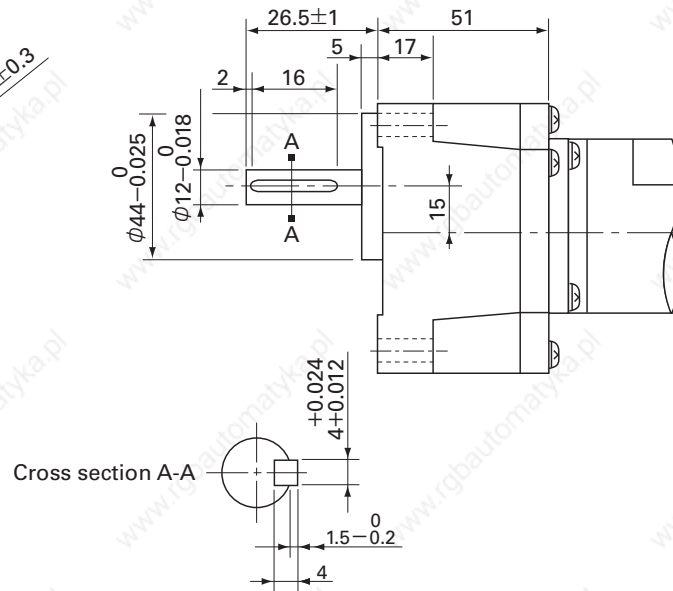
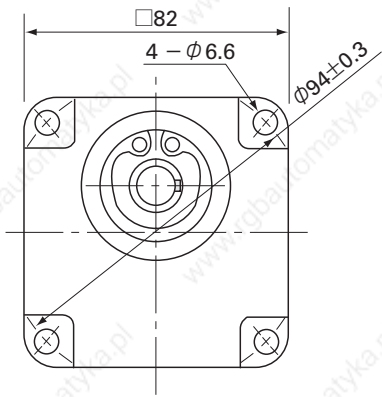

Dimensions of a typical gear for T7

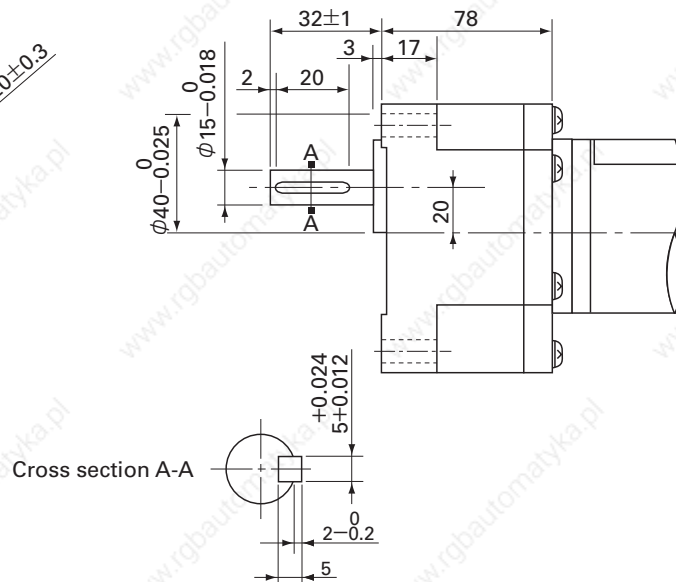
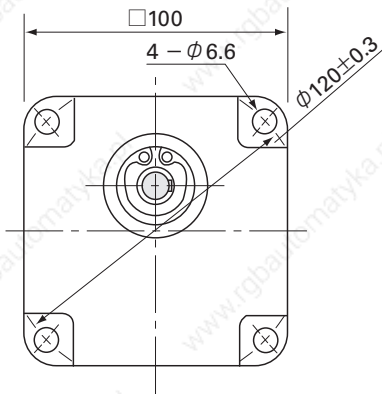

Servo Amplifier / Power Unit Dimensions

Servo amplifier

Unit : mm

TS1 □ 02 □ / TS1 □ A2 □

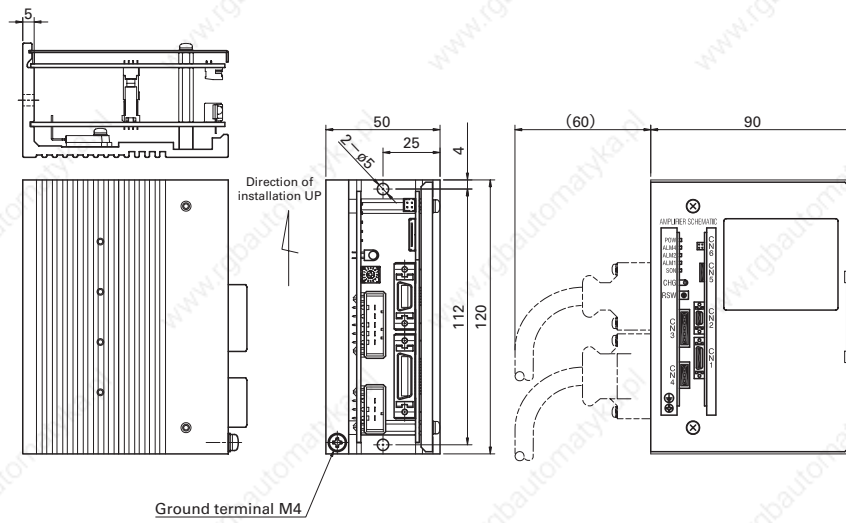

TS1 □ 03 □

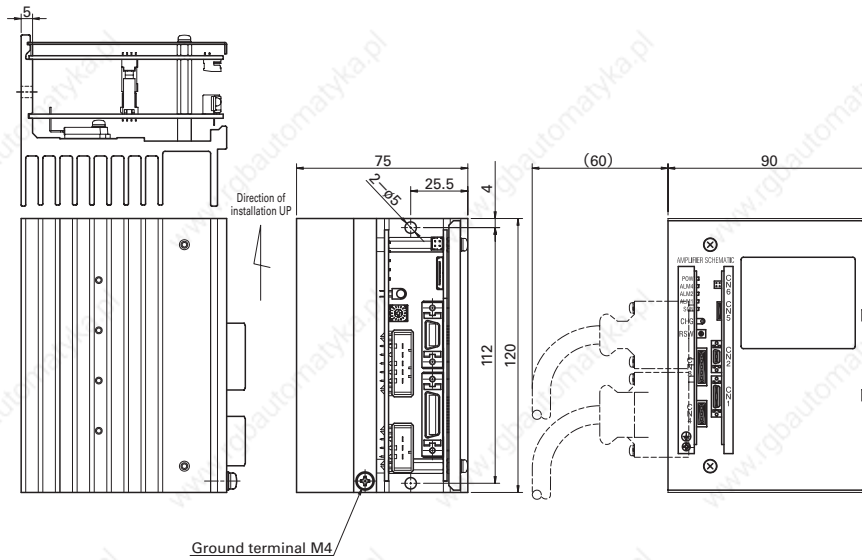

Power Unit

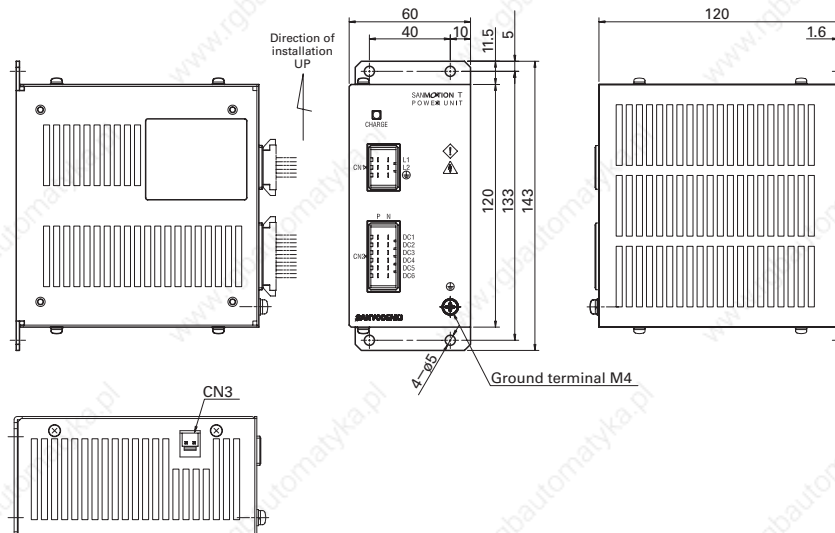

Features and Functions

Model Number Nomenclature

System Configuration

Standard Specifications

External Wiring Diagram

Dimensions

Setup Software

Optional Equipment

Setup Software

(1) Setup Software Start-up Screen



(2) Main Screen

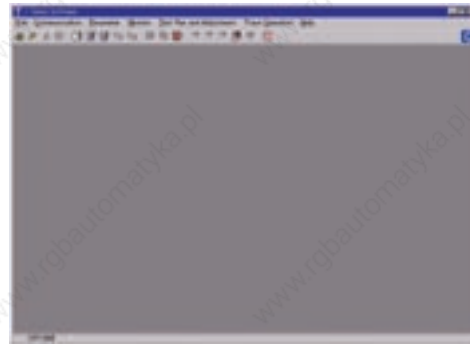

(3) Parameter Configuration Screen

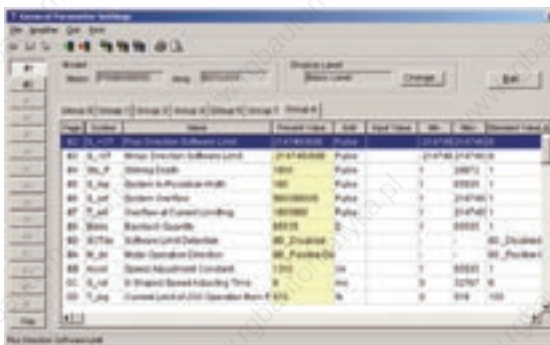

Configuration of General Parameters: Enables parameter loading, saving, etc., via PC connection

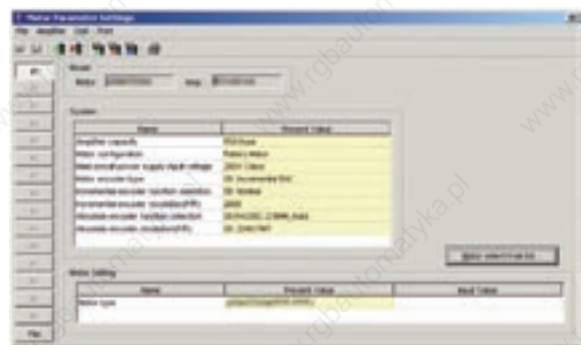

Configuration of Motor Parameters: Combined motors can be configured via PC connection

(4) Monitor Functions

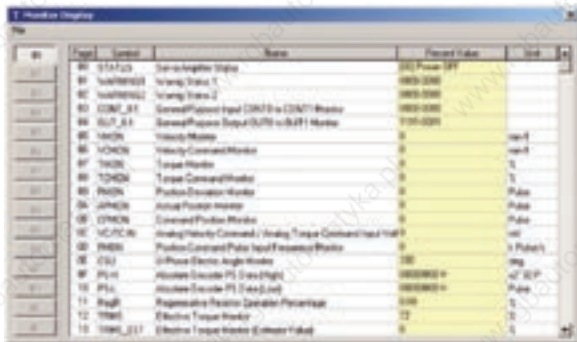

Monitor Display: Observe Operation and Input/Output signal status

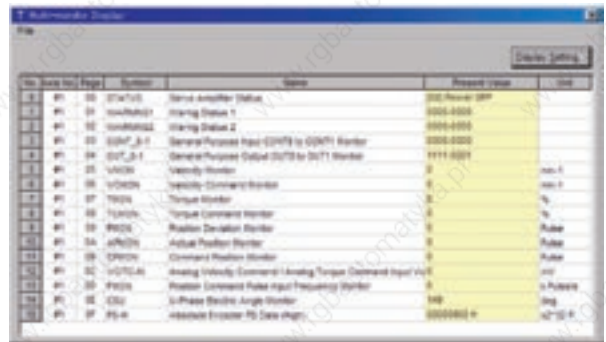

Multi-monitor Display: Simultaneous monitoring of operational status of multiple servo amplifiers networked to a PC.

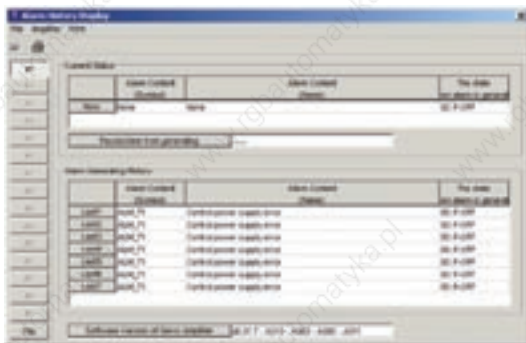

Alarm Record Display: (Current and past alarm occurrence can be checked.)

(5) Test Run and Adjustment Function

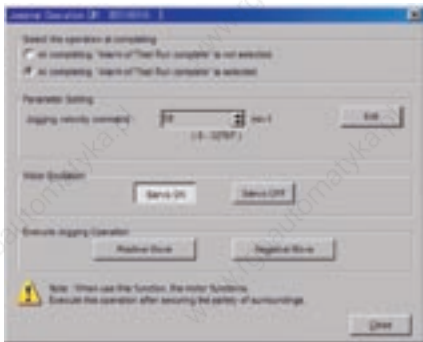

Speed Jogging:
Simplifies motor operation and the issuing of velocity commands from a PC



Pulse Feed Jogging:
Simplifies motor operation and the entering of distance and travel speed data from a PC

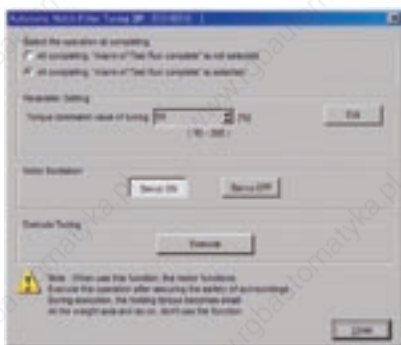

Automatic Notch Filter Tuning:
Configures the appropriate notch filter settings

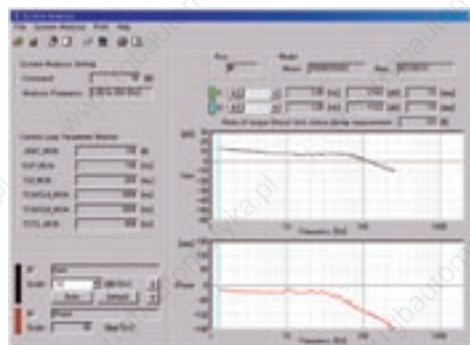

System Analysis:
Analyzes servo system frequency characteristics

(6) Trace Operation

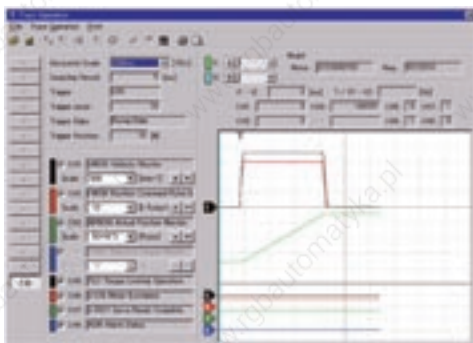

Graphically displays servo motor speed, current, and internal status

Features and Functions

Model Number Nomenclature

System Configuration

Standard Specifications

External Wiring Diagram

Dimensions

Setup Software

Optional Equipment

Optional Equipment

PC Interface Cable

Unit : mm

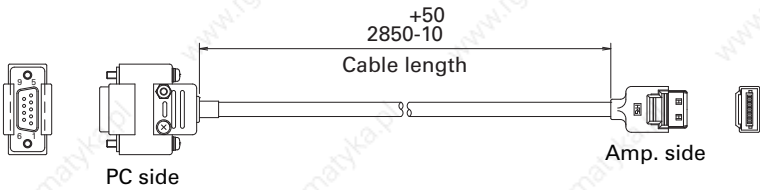

Model No.: AL-00490833-01

A note regarding RS-232C communications:
The user must provide a PC for computer interface.
Parameter settings may require adjustment.

Connector list (For Amplifier)

| | Contents | Model number | Manufacturer | Manufacturer's model number |
|------------------|-----------------------------|--------------|--|--|
| Single connector | CN1 (Plug and housing) | AL-00608709 | Sumitomo 3M Ltd./Molex Ltd. | 10126-3000PE + 10326-52A0-008/ 54306-2619 + 54331-0261 |
| | CN2 (Plug and housing) | AL-00608710 | Sumitomo 3M Ltd./Molex Ltd. | 10114-3000PE + 10314-52A0-008/ 54306-1419 + 54331-0141 |
| | CN3 (Housing and contact) | AL-00608711 | DDK Ltd./ Tyco Electronics AMP K.K. | DK-3100S-05R + DK-3RECLLP1-100/ 1-178288-5 + 1-175218-2 |
| | CN4 (Housing and contact) | AL-00608712 | DDK Ltd./ Tyco Electronics AMP K.K. | DK-3100S-03R + DK-3RECLLP1-100/ 1-178288-3 + 1-175218-2 |
| Standard set | CN1,2 (Plug and housing) | AL-00608713 | Sumitomo 3M Ltd./Molex Ltd. | 10126-3000PE + 10326-52A0-008/ 10114-3000PE + 10314-52A0-008/ 54306-2619 + 54331-0261 54306-1419 + 54331-0141 |
| | CN3,4 (Housing and contact) | | DDK Ltd./ Tyco Electronics AMP K.K. | DK-3100S-05R + DK-3RECLLP1-100/ DK-3100S-03R + DK-3RECLLP1-100/ 1-178288-5 + 1-175218-2 1-178288-3 + 1-175218-2 |

Note1) CN1,2 ... Sumitomo 3M company product and Molex company product are standardized goods.

Note2) CN3,4 ... DDK company product and Tyco electronics AMP company product are standardized goods.

* Hand crimp tool for contacts can be used for both.

Connector list (For Power Unit)

| | Contents | Model number | Manufacturer | Manufacturer's model number |
|------------------|-----------------------------|--------------|--|--|
| Single connector | CN1 (Housing and contact) | AL-00632983 | DDK Ltd./ Tyco Electronics AMP K.K. | DK-3100D-06R + DK-3RECLLP1-100/ 178289-3 + 1-175218-2 |
| | CN2 (Housing and contact) | AL-00632984 | DDK Ltd./ Tyco Electronics AMP K.K. | DK-3100D-12R + DK-3RECLLP1-100/ 178289-6 + 1-175218-2 |
| | CN3 (Housing and contact) | AL-00632985 | J.S.T Mfg Co Ltd. | VHR-2N + SVH-21T-P1.1 |
| Standard set | CN1,2 (Housing and contact) | AL-00632986 | DDK Ltd./ Tyco Electronics AMP K.K. | DK-3100D-06R + DK-3RECLLP1-100/ DK-3100D-12R + DK-3RECLLP1-100/ 178289-3 + 1-175218-2 178289-6 + 1-175218-2 |
| | CN3 (Housing and contact) | | J.S.T Mfg Co Ltd. | VHR-2N + SVH-21T-P1.1 |

Note1) CN1,2 ... DDK company product and Tyco electronics AMP company product are standardized goods.

* Hand crimp tool for contacts can be used for both.

Note2) Standard set(AL-00632986) is attached to the Power Unit.

Brush (Maintenance components)

| Applicable motor | Model number |
|---|---------------|
| For T4 model motor | S441898-1A-02 |
| For T5 model motor | S441899-1A-02 |
| For T7 model motor | S442425-1A-02 |
| For T8 model motor | S442427-1A-02 |
| For T4 model tachometer generator-equipped motor | S813053-1A-87 |
| For T5 model tachometer generator-equipped motor | S782281-1A-87 |
| For T7 and T8 model tachometer generator-equipped motor | S782279-1A-87 |

Regenerative Resistor

| Regenerative power [PM] | Model number | Resistance | Allowable power [PRO] | Thermostat |
|-------------------------|-------------------|------------|-----------------------|------------|
| 10W Max. | REGIST-080W50B | 50 Ω | 10W | b contact |
| 30W Max. | REGIST-120W50B | 50 Ω | 30W | |
| Less than 55W | REGIST-220W50B | 50 Ω | 55W | |
| | REGIST-220W20B | 20 Ω | | |
| 55W Min. | Please contact us | | | |

External Regenerative Resistor Dimensions

(Unit: mm)

REGIST-080W50B

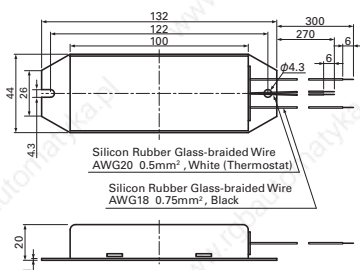

Mass : 0.19kg

REGIST-120W50B

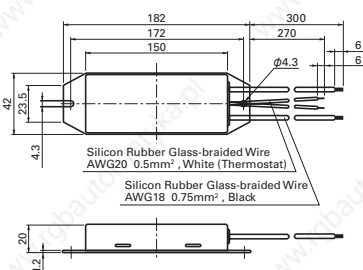

Mass : 0.24kg

REGIST-220W20B, REGIST-220W50B

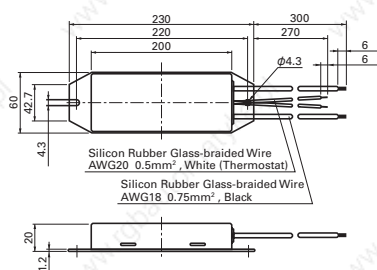

Mass : 0.44kg

www.rgbautomatyka.pl

Features and Functions

Model Number Nomenclature

System Configuration

Standard Specifications

External Wiring Diagram

Dimensions

Setup Software

Optional Equipment

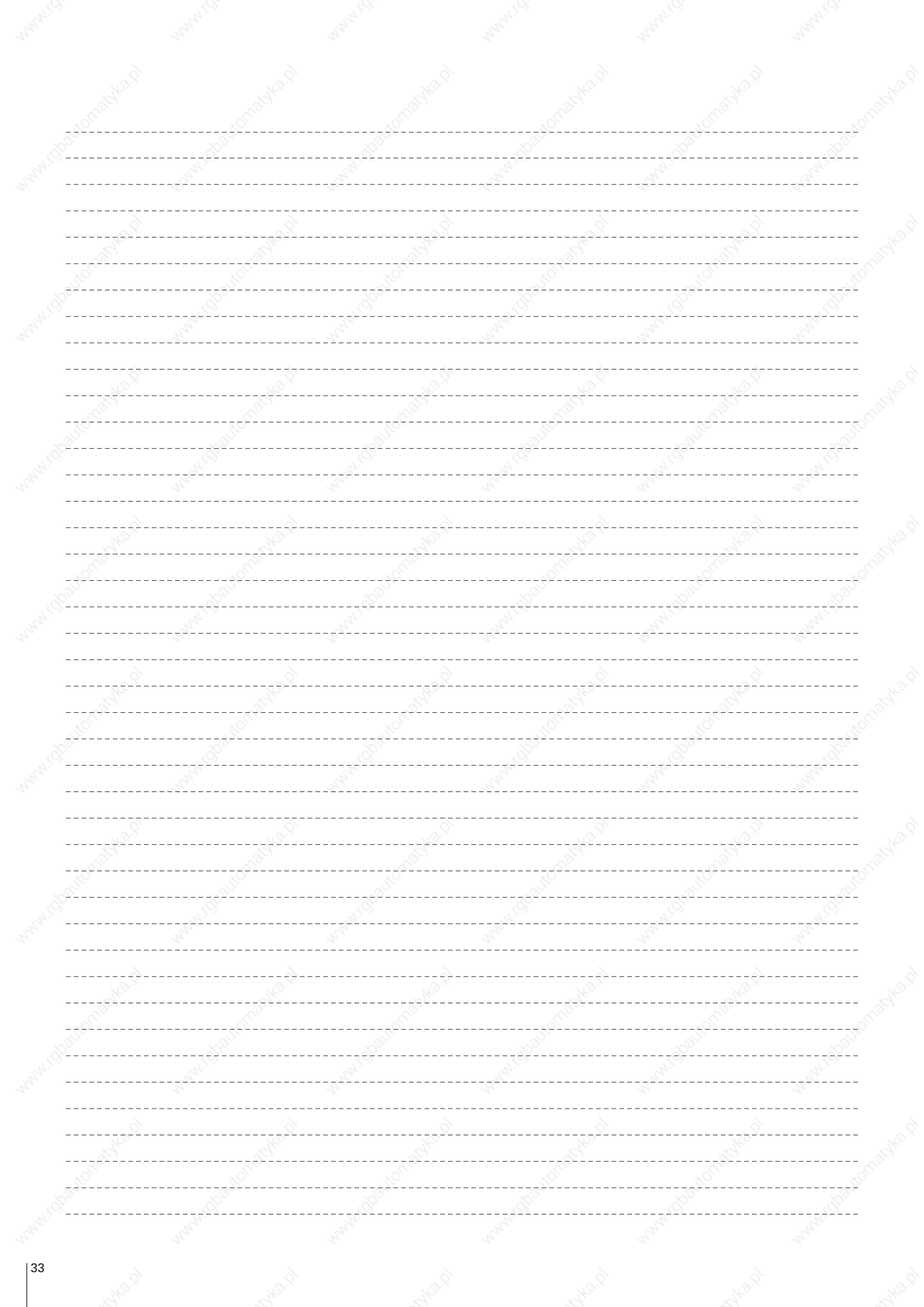

Inquiry Check Sheet

Please provide the following information when placing an order or making an inquiry.
Also feel free to include any questions that require our attention.

Company Name : _____

Date : _____

Department : _____

To contact us : _____

Telephone : _____

Phone : +81 3 3917 4141

Fax : _____

FAX : +81 3 5394 3427

1) Application : _____

2) Name of Machinery : _____

3) Number of Units : _____

| Item | Contents | | | | | | | | | | | | | | | | | | | | | | | | | | | | | | | | | | | | | | | | | | | | | | | | | | | | | | | | | | | | | | | | | | | | | | | | | | | | | | | | | | | | | | | | | | |
|---|--|--|--------------------|---|--------------------|--------------------------------|----|----------------|----|----------------------|----|--------------------------|----|-------------------------------------|---|-------------------------|---|------------------------|---|--------------------------------|----|-----------------------------------|----|--|--|------------------------------|----|---------------------------------|----|---------------------|--|----------------------------|-------------------|-----------------------|-------------------|--|--|------------------|-------------------|--|-------------------|--|--|--------------------------|----|------------------------------|----|----------------------|----|-----------------------------|----|--------------------------|----|-----------------------|----|---------------------|----|-----------------------------|----|---------------------------|----|---------------------------|----|-------------------------|----|--|--|--|--|--|--|--|--------------------|---|--|--|--------------------|---|--|--------------------------------|--|--|--|--|-------------------|---|-----|--|--|--|-----|
| ① | Name of target equipment Equipment name, category (transport, processing, test, other) | | | | | | | | | | | | | | | | | | | | | | | | | | | | | | | | | | | | | | | | | | | | | | | | | | | | | | | | | | | | | | | | | | | | | | | | | | | | | | | | | | | | | | | | | | |
| ② | Name of servo axis Axis name, axial mechanism (horizontal/vertical), brake mechanism (yes/no) | | | | | | | | | | | | | | | | | | | | | | | | | | | | | | | | | | | | | | | | | | | | | | | | | | | | | | | | | | | | | | | | | | | | | | | | | | | | | | | | | | | | | | | | | | |
| ③ | Current condition of above axis Manufacturer Name () Series Name () Motor Capacity () Hydraulic, Mechanical, or New System () | | | | | | | | | | | | | | | | | | | | | | | | | | | | | | | | | | | | | | | | | | | | | | | | | | | | | | | | | | | | | | | | | | | | | | | | | | | | | | | | | | | | | | | | | | |
| ④ | Positioning accuracy \pm mm \pm μ m | | | | | | | | | | | | | | | | | | | | | | | | | | | | | | | | | | | | | | | | | | | | | | | | | | | | | | | | | | | | | | | | | | | | | | | | | | | | | | | | | | | | | | | | | | |
| ⑤ | Operation pattern <div style="display: flex; align-items: center;"> <div style="flex: 1;"> <p style="font-size: small;">Acceleration α: ___ G ___ [m/s²] Feeding Speed V: ___ [m/s] Moving Distance D: ___ [m] (Stroke)</p> <p style="font-size: x-small;"> ← t1 () → ← t2 () → ← t3 () → Time [sec]</p> </div> <div style="flex: 1; padding-left: 10px;"> <p>[Reference formula] $1G = 9.8 [m/s^2], 1 [m/s^2] \approx 0.1G$ $\alpha [m/s^2] = V [m/sec] \div t1 [sec]$ $D [m] = V [m/sec] \times (t1 + t2) [sec]$</p> </div> </div> | | | | | | | | | | | | | | | | | | | | | | | | | | | | | | | | | | | | | | | | | | | | | | | | | | | | | | | | | | | | | | | | | | | | | | | | | | | | | | | | | | | | | | | | | | |
| ⑥ | Mechanism Ball-screw/screw-rotation type (horizontal), ball-screw/nut-rotation type (horizontal), rack and pinion (horizontal), belt/chain (horizontal), rotary table, roll feed, instability | | | | | | | | | | | | | | | | | | | | | | | | | | | | | | | | | | | | | | | | | | | | | | | | | | | | | | | | | | | | | | | | | | | | | | | | | | | | | | | | | | | | | | | | | | |
| ⑦ | Mechanical structure <table style="width: 100%; font-size: x-small; border-collapse: collapse;"> <tr> <td>WT (table mass)</td><td>kg</td><td>WL (work mass)</td><td>kg</td><td>WA (mass of other drive parts)</td><td>kg</td> </tr> <tr> <td>WR (rack mass)</td><td>kg</td><td>WB (belt/chain mass)</td><td>kg</td><td>WC (counterbalance mass)</td><td>kg</td> </tr> <tr> <td>Fa (external force axial direction)</td><td>N</td><td>Fb (ball-screw preload)</td><td>N</td><td>T (roll pushing force)</td><td>N</td> </tr> <tr> <td>Dr1 (drive-side roll diameter)</td><td>mm</td><td>Dr2 (follower-side roll diameter)</td><td>mm</td><td></td><td></td> </tr> <tr> <td>Lr1 (drive-side roll length)</td><td>mm</td><td>Lr2 (follower-side roll length)</td><td>mm</td><td>G (reduction ratio)</td><td></td> </tr> <tr> <td>JG (speed-reducer inertia)</td><td>kg·m²</td><td>JC (coupling inertia)</td><td>kg·m²</td><td></td><td></td> </tr> <tr> <td>JN (nut inertia)</td><td>kg·m²</td><td>JO (other motor-axis conversion inertia)</td><td>kg·m²</td><td></td><td></td> </tr> <tr> <td>Db (ball-screw diameter)</td><td>mm</td><td>Lb (ball-screw axial length)</td><td>mm</td><td>Pb (ball-screw lead)</td><td>mm</td> </tr> <tr> <td>Dp (pinion/pulley diameter)</td><td>mm</td><td>Lp (pinion axial length)</td><td>mm</td><td>tp (pulley thickness)</td><td>mm</td> </tr> <tr> <td>Dt (table diameter)</td><td>mm</td><td>Dh (table-support diameter)</td><td>mm</td><td>LW (load shift from axis)</td><td>mm</td> </tr> <tr> <td>Ds (table shaft diameter)</td><td>mm</td><td>Ls (table shaft length)</td><td>mm</td><td></td><td></td> </tr> <tr> <td>ρ (specific gravity of ball-screw/pinion/pulley/table-shaft material)</td><td></td><td>$\rho 1$ (specific gravity of roll-1 material)</td><td></td><td></td><td>kg/cm³</td> </tr> <tr> <td>μ (friction coefficient between sheet and sliding-surface/support-section/roll)</td><td></td><td>$\rho 2$ (specific gravity of roll-2 material)</td><td>kg/cm³</td><td>κ (internal friction coefficient of preload nut)</td><td></td> </tr> <tr> <td>η (mechanical efficiency)</td><td></td><td>JL (load inertia of motor-axis conversion)</td><td></td><td></td><td>kg·m²</td> </tr> <tr> <td>TF (friction torque of motor axis conversion)</td><td>N·m</td><td>Tu (imbalance torque of motor axis conversion)</td><td></td><td></td><td>N·m</td> </tr> </table> | WT (table mass) | kg | WL (work mass) | kg | WA (mass of other drive parts) | kg | WR (rack mass) | kg | WB (belt/chain mass) | kg | WC (counterbalance mass) | kg | Fa (external force axial direction) | N | Fb (ball-screw preload) | N | T (roll pushing force) | N | Dr1 (drive-side roll diameter) | mm | Dr2 (follower-side roll diameter) | mm | | | Lr1 (drive-side roll length) | mm | Lr2 (follower-side roll length) | mm | G (reduction ratio) | | JG (speed-reducer inertia) | kg·m ² | JC (coupling inertia) | kg·m ² | | | JN (nut inertia) | kg·m ² | JO (other motor-axis conversion inertia) | kg·m ² | | | Db (ball-screw diameter) | mm | Lb (ball-screw axial length) | mm | Pb (ball-screw lead) | mm | Dp (pinion/pulley diameter) | mm | Lp (pinion axial length) | mm | tp (pulley thickness) | mm | Dt (table diameter) | mm | Dh (table-support diameter) | mm | LW (load shift from axis) | mm | Ds (table shaft diameter) | mm | Ls (table shaft length) | mm | | | ρ (specific gravity of ball-screw/pinion/pulley/table-shaft material) | | $\rho 1$ (specific gravity of roll-1 material) | | | kg/cm ³ | μ (friction coefficient between sheet and sliding-surface/support-section/roll) | | $\rho 2$ (specific gravity of roll-2 material) | kg/cm ³ | κ (internal friction coefficient of preload nut) | | η (mechanical efficiency) | | JL (load inertia of motor-axis conversion) | | | kg·m ² | TF (friction torque of motor axis conversion) | N·m | Tu (imbalance torque of motor axis conversion) | | | N·m |
| WT (table mass) | kg | WL (work mass) | kg | WA (mass of other drive parts) | kg | | | | | | | | | | | | | | | | | | | | | | | | | | | | | | | | | | | | | | | | | | | | | | | | | | | | | | | | | | | | | | | | | | | | | | | | | | | | | | | | | | | | | | |
| WR (rack mass) | kg | WB (belt/chain mass) | kg | WC (counterbalance mass) | kg | | | | | | | | | | | | | | | | | | | | | | | | | | | | | | | | | | | | | | | | | | | | | | | | | | | | | | | | | | | | | | | | | | | | | | | | | | | | | | | | | | | | | | |
| Fa (external force axial direction) | N | Fb (ball-screw preload) | N | T (roll pushing force) | N | | | | | | | | | | | | | | | | | | | | | | | | | | | | | | | | | | | | | | | | | | | | | | | | | | | | | | | | | | | | | | | | | | | | | | | | | | | | | | | | | | | | | | |
| Dr1 (drive-side roll diameter) | mm | Dr2 (follower-side roll diameter) | mm | | | | | | | | | | | | | | | | | | | | | | | | | | | | | | | | | | | | | | | | | | | | | | | | | | | | | | | | | | | | | | | | | | | | | | | | | | | | | | | | | | | | | | | | |
| Lr1 (drive-side roll length) | mm | Lr2 (follower-side roll length) | mm | G (reduction ratio) | | | | | | | | | | | | | | | | | | | | | | | | | | | | | | | | | | | | | | | | | | | | | | | | | | | | | | | | | | | | | | | | | | | | | | | | | | | | | | | | | | | | | | | |
| JG (speed-reducer inertia) | kg·m ² | JC (coupling inertia) | kg·m ² | | | | | | | | | | | | | | | | | | | | | | | | | | | | | | | | | | | | | | | | | | | | | | | | | | | | | | | | | | | | | | | | | | | | | | | | | | | | | | | | | | | | | | | | |
| JN (nut inertia) | kg·m ² | JO (other motor-axis conversion inertia) | kg·m ² | | | | | | | | | | | | | | | | | | | | | | | | | | | | | | | | | | | | | | | | | | | | | | | | | | | | | | | | | | | | | | | | | | | | | | | | | | | | | | | | | | | | | | | | |
| Db (ball-screw diameter) | mm | Lb (ball-screw axial length) | mm | Pb (ball-screw lead) | mm | | | | | | | | | | | | | | | | | | | | | | | | | | | | | | | | | | | | | | | | | | | | | | | | | | | | | | | | | | | | | | | | | | | | | | | | | | | | | | | | | | | | | | |
| Dp (pinion/pulley diameter) | mm | Lp (pinion axial length) | mm | tp (pulley thickness) | mm | | | | | | | | | | | | | | | | | | | | | | | | | | | | | | | | | | | | | | | | | | | | | | | | | | | | | | | | | | | | | | | | | | | | | | | | | | | | | | | | | | | | | | |
| Dt (table diameter) | mm | Dh (table-support diameter) | mm | LW (load shift from axis) | mm | | | | | | | | | | | | | | | | | | | | | | | | | | | | | | | | | | | | | | | | | | | | | | | | | | | | | | | | | | | | | | | | | | | | | | | | | | | | | | | | | | | | | | |
| Ds (table shaft diameter) | mm | Ls (table shaft length) | mm | | | | | | | | | | | | | | | | | | | | | | | | | | | | | | | | | | | | | | | | | | | | | | | | | | | | | | | | | | | | | | | | | | | | | | | | | | | | | | | | | | | | | | | | |
| ρ (specific gravity of ball-screw/pinion/pulley/table-shaft material) | | $\rho 1$ (specific gravity of roll-1 material) | | | kg/cm ³ | | | | | | | | | | | | | | | | | | | | | | | | | | | | | | | | | | | | | | | | | | | | | | | | | | | | | | | | | | | | | | | | | | | | | | | | | | | | | | | | | | | | | | |
| μ (friction coefficient between sheet and sliding-surface/support-section/roll) | | $\rho 2$ (specific gravity of roll-2 material) | kg/cm ³ | κ (internal friction coefficient of preload nut) | | | | | | | | | | | | | | | | | | | | | | | | | | | | | | | | | | | | | | | | | | | | | | | | | | | | | | | | | | | | | | | | | | | | | | | | | | | | | | | | | | | | | | | |
| η (mechanical efficiency) | | JL (load inertia of motor-axis conversion) | | | kg·m ² | | | | | | | | | | | | | | | | | | | | | | | | | | | | | | | | | | | | | | | | | | | | | | | | | | | | | | | | | | | | | | | | | | | | | | | | | | | | | | | | | | | | | | |
| TF (friction torque of motor axis conversion) | N·m | Tu (imbalance torque of motor axis conversion) | | | N·m | | | | | | | | | | | | | | | | | | | | | | | | | | | | | | | | | | | | | | | | | | | | | | | | | | | | | | | | | | | | | | | | | | | | | | | | | | | | | | | | | | | | | | |
| ⑧ | Speed reducer Customer-provided (/) Sanyo denki standard (planet/spur/no-backlash-planet /) other (/) | | | | | | | | | | | | | | | | | | | | | | | | | | | | | | | | | | | | | | | | | | | | | | | | | | | | | | | | | | | | | | | | | | | | | | | | | | | | | | | | | | | | | | | | | | |
| ⑨ | Types of detector Encoder type specified (yes / no) Yes: (incremental encoder, absolute encoder) Resolution () Tachometer generator | | | | | | | | | | | | | | | | | | | | | | | | | | | | | | | | | | | | | | | | | | | | | | | | | | | | | | | | | | | | | | | | | | | | | | | | | | | | | | | | | | | | | | | | | | |
| ⑩ | Input format Position, velocity, torque, other () | | | | | | | | | | | | | | | | | | | | | | | | | | | | | | | | | | | | | | | | | | | | | | | | | | | | | | | | | | | | | | | | | | | | | | | | | | | | | | | | | | | | | | | | | | |
| ⑪ | Host equipment (controller) Sequencer, laptop, customer-developed product, Sanyo denki-provided, other () | | | | | | | | | | | | | | | | | | | | | | | | | | | | | | | | | | | | | | | | | | | | | | | | | | | | | | | | | | | | | | | | | | | | | | | | | | | | | | | | | | | | | | | | | | |
| ⑫ | Usage environment and other requirements Cutting, clean-room use, anti-dust measures, other () | | | | | | | | | | | | | | | | | | | | | | | | | | | | | | | | | | | | | | | | | | | | | | | | | | | | | | | | | | | | | | | | | | | | | | | | | | | | | | | | | | | | | | | | | | |
| ⑬ | Estimated production Single product: () units/month () units/year | | | | | | | | | | | | | | | | | | | | | | | | | | | | | | | | | | | | | | | | | | | | | | | | | | | | | | | | | | | | | | | | | | | | | | | | | | | | | | | | | | | | | | | | | | |
| ⑭ | Development schedule Prototype period: () Year () Month Production period: () Year () Month | | | | | | | | | | | | | | | | | | | | | | | | | | | | | | | | | | | | | | | | | | | | | | | | | | | | | | | | | | | | | | | | | | | | | | | | | | | | | | | | | | | | | | | | | | |
| ⑮ | Various measures Related documentation (already submitted; send later by mail) Visit/PR desired (yes / no) Meeting desired (yes / no) | | | | | | | | | | | | | | | | | | | | | | | | | | | | | | | | | | | | | | | | | | | | | | | | | | | | | | | | | | | | | | | | | | | | | | | | | | | | | | | | | | | | | | | | | | |
| ⑯ | Miscellaneous (questions, pending problems, unresolved issues, etc.) | | | | | | | | | | | | | | | | | | | | | | | | | | | | | | | | | | | | | | | | | | | | | | | | | | | | | | | | | | | | | | | | | | | | | | | | | | | | | | | | | | | | | | | | | | |

■ Precautions For Adoption

Failure to follow the precautions on the right may cause moderate injury and property damage, or in some circumstances, could lead to a serious accident. Always follow all listed precautions.

Cautions

- Read the accompanying Instruction Manual carefully prior to using the product.
- If applying to medical devices and other equipment affecting people's lives, please contact us beforehand and take appropriate safety measures.
- If applying to equipment that can have significant effects on society and the general public, please contact us beforehand.
- Do not use this product in an environment where vibration is present, such as in a moving vehicle or shipping vessel.
- Do not perform any retrofitting, re-engineering, or modification to this equipment.
- The products presented in this catalog are meant to be used for general industrial applications. If using for special applications related to aviation and space, nuclear power, electric power, submarine repeaters, etc., please contact us beforehand.

*For any question or inquiry regarding the above, contact our Sales Department.

SANYO DENKI CO., LTD.

1-15-1, Kita-Otsuka, Toshima-ku, Tokyo 170-8451, Japan

<http://www.sanyodenki.com>

Phone: +81 3 3917 5157

SANYO DENKI AMERICA, INC.

468 Amapola Avenue Torrance, CA 90501 U.S.A.

Phone: +1 310 783 5400

SANYO DENKI EUROPE SA.

P.A. Paris Nord II 48 Allee des Erables-VILLEPINTE BP.57286 F-95958 ROISSY CDG Cedex France

Phone: +33 1 48 63 26 61

SANYO DENKI GERMANY GmbH

Frankfurter Strasse 92, 65760 Eschborn Germany

Phone: +49 6196 76113 0

SANYO DENKI KOREA CO., LTD.

9F 5-2, Sunwha-dong Jung-gu Seoul, 100-130, Korea

Phone: +82 2 773 5623

SANYO DENKI SHANGHAI CO., LTD.

Rm2107-2109, Bldg A, Far East International Plaza, No.319, Xianxia Rd., Shanghai, 200051, China

Phone: +86 21 6235 1107

SANYO DENKI TAIWAN CO., LTD.

Room 1208, 12F, No.96 Chung Shan N, Rd., Sec.2, Taipei 104, Taiwan, R.O.C.

Phone: +886 2 2511 3938

SANYO DENKI (H.K.) CO., LIMITED

Room 2305, 23/F, South Tower, Concordia Plaza, 1 Science Museum Rd., TST East, Kowloon, Hong Kong

Phone: +852 2312 6250

SANYO DENKI SINGAPORE PTE. LTD.

10 Hoe Chiang Road #14-03A/04 Keppel Towers Singapore 089315

Phone: +65 6223 1071

The names of companies and/or their products specified in this catalogue are the trade names, and/or trademarks and/or registered trademarks of such respective companies.

*Remarks : Specifications Are Subject To Change Without Notice.

CATALOG NO. S0767B008 '12.12.A