

**Datex-Ohmeda**  
**S/5™ Light Monitor, F-LM1, F-LMP1**  
**Technical Reference Manual**



All specifications are subject to change without notice.

Document No. 8000060-2

October 2004

Datex-Ohmeda, Inc.  
P.O. Box 7550, Madison  
WI 53707-7550, USA  
Tel. +1-608-221-1551  
Fax +1-608-222-9147  
[www.us.datex-ohmeda.com](http://www.us.datex-ohmeda.com)

GE Healthcare Finland Oy  
Helsinki, Finland  
P.O. Box 900  
FI-00031 GE  
Tel: +358 10 39411, Fax: +358 9 1463310  
[www.datex-ohmeda.com](http://www.datex-ohmeda.com)  
[www.gehealthcare.com](http://www.gehealthcare.com)

© General Electric company. All rights reserved.

## Intended purpose

Datex-Ohmeda S/5 Light Monitor is intended for stationary and mobile monitoring of patient's ECG, SpO<sub>2</sub>, non-invasive and invasive blood pressure, temperature, respiration and CO<sub>2</sub> in hospitals and ambulances. When used outdoors, the monitor must be in the protective case.

The monitor is intended for use by qualified medical personnel only.

The S/5 Light Monitor is intended for patients with weight from 5 kg (11 lb.) up.

Respiration monitoring is intended for patients three years old and up.

## Classification according to IEC 60601-1

- CLASS I EQUIPMENT and INTERNALLY POWERED EQUIPMENT according to the type of protection against electrical shock.
- TYPE BF or CF equipment according to the degree of protection against electric shock is indicated with a symbol beside each patient connector.
- Degree of protection against harmful ingress of water as detailed in the IEC 60529:  
Monitor: IPX1, vertically falling water drops shall have no harmful effects (applicable when the monitor is in upright position, or tilted backwards). In the protective case IPX4, splash proof, when the case is closed properly, the monitor is intact and operates on battery power.  
Power adapter: IPX0, ordinary equipment.  
Power adapter for Transport Vehicles: IPX1.
- EQUIPMENT not suitable for use in the presence of a FLAMMABLE ANESTHETIC MIXTURE with air or with oxygen or nitrous oxide.
- CONTINUOUS OPERATION according to the mode of operation.
- CISPR 11: Group 1 class A

## Classification according to EU Medical Device Directive

- The monitor is classified as IIb.

## Responsibility of the manufacturer

Instrumentarium Corp. is responsible for the effects on safety, reliability and performance of the equipment only if:

- assembly, operations, extensions, readjustments, modifications, service and repairs are carried out by authorized personnel.
- the electrical installation of the relevant room complies with appropriate requirements.
- the equipment is used in accordance with the User's Reference Manual and serviced and maintained in accordance with the Technical Reference Manual.

The CO<sub>2</sub> measuring option (N-LCM) is manufactured for Instrumentarium Corp. by Pryon Corp., 8500 S.W. Creekside Place, Beaverton, OR 97008-7107 USA.

The Nellcor option (N-LNSAT) is manufactured for Instrumentarium Corp. by Mallinckrodt Inc., 675 McDonnell Boulevard, P.O. Box 5840, St. Louis, MO 63134 USA.

## Trademarks

ComWheel, Datex-Ohmeda S/5, Datex-Ohmeda AS/3, Datex-Ohmeda CS/3, Light, EarSat, FingerSat and Flexlite are trademarks of Instrumentarium Corp.

## Storage and transport

For allowed storage and transport conditions refer to the documentation delivered with the monitor.

All specifications subject to change without notice.

© 2004 General Electric Company. All rights reserved.

## Datex-Ohmeda S/5™ Light Monitor Technical Reference Manual, 8000060-2

### PART I, General Service Guide

Document No.	Updated	Updated	Description	
8000060-2			Introduction, Safety, Architecture, Functional check, Service check, General troubleshooting, Service Menu, General specifications	1
8001934-1			Planned Maintenance Instructions	2

### PART II, Product Service Guide

8000060-1			CPU	1
8000060-1			Power Supply Unit	2
8000060-1			Hemodynamic Unit	3
8000060-1			CO <sub>2</sub> Unit	4
8000060-1			Isolation Power Supply Unit for CO <sub>2</sub> Unit	5
890201-5			Datex-Ohmeda Light Monitor Recorder, N-LREC	6
890202-5			Datex-Ohmeda Light Monitor Power Adapter, N-LPOW and N-LPOWT	7
890200-5			Datex-Ohmeda Light Monitor Battery Module, F-LBAT	8
896192-1			Datex-Ohmeda External Battery Charger, N-LGHR	9
8000060-1			DataCard and Network Options, N-LDATA, N-NET, N-LDNET	10
8000060-1			Spare Parts, Upgrade Kits and Exploded Views	11
896551-2			Optional N-LCM Upgrade for Light Monitor	
896552-2			Optional N-LDNET Upgrade for Light Monitor	
896553-2			Optional N-LDATA Upgrade for Light Monitor	
896554-2			Optional N-LNET Upgrade for Light Monitor	





# TABLE OF CONTENTS

## PART 1 - GENERAL SERVICE GUIDE

<b>TABLE OF CONTENTS</b>	<b>i</b>
<b>Part 1 - General Service Guide</b>	<b>i</b>
<b>1 INTRODUCTION</b>	<b>1</b>
1.1 Notes to the reader.....	2
1.1.1 Intended purpose .....	2
1.1.2 Trademarks .....	2
1.1.3 Copyright.....	2
1.2 About this manual .....	3
1.3 Related documents .....	3
1.4 Installation .....	3
1.4.1 Choosing the location .....	3
1.5 Symbols .....	4
1.5.1 Symbols on equipment .....	4
1.5.2 Symbols on transport packaging.....	6
<b>2 SAFETY</b>	<b>7</b>
2.1 Equipment classification .....	7
2.1.1 Classification according to IEC 60601-1 .....	7
2.1.2 Classification according to EU Medical Device Directive.....	7
2.1.3 Responsibility of the manufacturer.....	7
2.2 Safety precautions .....	8
2.2.1 Warnings .....	8
2.2.2 Cautions.....	11
2.3 Safety test .....	12
<b>3 ARCHITECTURE</b>	<b>13</b>
3.1 Monitor structure.....	13
3.2 Power supply unit.....	15
3.3 CPU .....	15
3.4 NIBP unit .....	16
3.5 ECG unit .....	16
3.6 STP unit .....	16
3.7 CO <sub>2</sub> unit.....	16
3.8 Display unit.....	17
3.8.1 Slave display .....	17
3.9 Power adapters .....	17
3.9.1 N-LPOW.....	17
3.9.2 N-LPOWT .....	17
3.10 Host serial communications .....	17
3.10.1 Module bus .....	17
3.10.2 Computer interface (RS-232) .....	17
3.10.3 CO <sub>2</sub> module.....	18
3.10.4 Nellcor compatible SpO <sub>2</sub> -module .....	18
3.10.5 Power board .....	18
3.10.6 Recorder .....	18
<b>4 CLEANING</b>	<b>19</b>

<b>5</b>	<b>FUNCTIONAL CHECK</b>	<b>21</b>
5.1	General functional inspection .....	22
5.1.1	Recorder test.....	23
5.1.2	PCMCIA card test.....	23
5.1.3	Network test.....	24
5.1.4	ECG board tests.....	25
5.1.5	STP board tests .....	25
5.1.6	NIBP board test .....	26
5.1.7	Mainstream CO <sub>2</sub> test.....	26
5.2	Performance checks.....	27
<b>6</b>	<b>SERVICE CHECK</b>	<b>31</b>
6.1	General service information .....	31
6.2	Service check procedure .....	31
6.2.1	Visual inspection .....	32
6.2.2	Recorder test.....	35
6.2.3	PCMCIA card test.....	36
6.2.4	Network test .....	36
6.2.5	ECG measurement.....	36
6.2.6	Respiration measurement.....	38
6.2.7	Temperature measurement .....	40
6.2.8	Invasive blood pressure measurement.....	40
6.2.9	SpO <sub>2</sub> measurement .....	41
6.2.10	Non Invasive Blood Pressure measurement .....	42
6.2.11	Mainstream CO <sub>2</sub> measurement .....	44
6.2.12	For Light Monitor.....	45
<b>7</b>	<b>Adjustments and calibrations</b>	<b>47</b>
7.1	Pressure safety level detection "OFFSET" .....	47
7.2	NIBP calibrations .....	47
7.2.1	Calibration check.....	47
7.2.2	Calibration .....	48
7.3	Temperature calibration .....	49
7.4	Invasive pressure calibration .....	50
<b>8</b>	<b>GENERAL TROUBLESHOOTING</b>	<b>51</b>
8.1	Troubleshooting flowchart .....	51
<b>9</b>	<b>SERVICE MENU</b>	<b>53</b>
9.1	SW version / unit ID .....	53
9.2	Language selection .....	54
9.3	Monitor configuration .....	54
<b>10</b>	<b>GENERAL SPECIFICATIONS</b>	<b>55</b>
10.1	Parameter specifications.....	55
10.1.1	ECG .....	55
10.1.2	Impedance respiration.....	55
10.1.3	Pulse oximetry (SpO <sub>2</sub> )/Pleth.....	56
10.1.4	Temperature.....	56
10.1.5	Non-invasive blood pressure .....	57
10.1.6	Invasive blood pressure (LMP1 models only).....	57
10.1.7	CO <sub>2</sub> (option N-LCM) .....	59
10.2	General .....	59
10.2.1	Environmental conditions .....	60
10.3	Option codes .....	60

---

10.4	Display .....	60
10.4.1	Slave display .....	60
10.4.2	Trends .....	61
10.4.3	Alarms .....	61
10.5	Light Monitor battery module (optional) (w/2 battery slots) .....	61
10.6	Light Monitor backup battery (optional) .....	61
10.7	External power adapter .....	61
10.8	Power adapter for transport vehicles (optional) .....	61
10.9	Light External Battery Charger (optional) .....	61
10.10	Output specifications .....	62
10.10.1	Nurse Call and Defibrillator Synchronization Signals .....	62
<b>FUNCTIONAL CHECK form</b>		<b>A-1</b>
<b>SERVICE CHECK form</b>		<b>B-1</b>
<b>EMC Guidance</b>		<b>C-1</b>

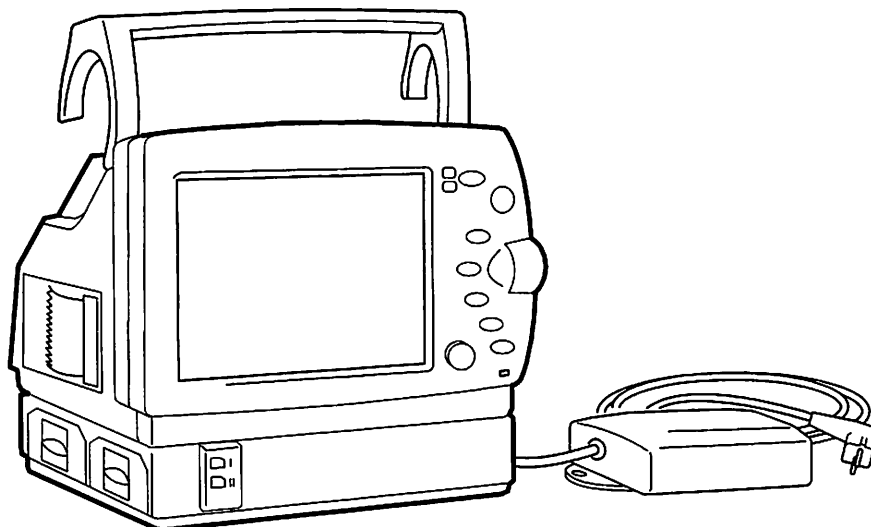
## TABLE OF FIGURES

Figure 1	S/5 Light Monitor with battery module and power adapter	1
Figure 2	Main block diagram of Light Monitor, revision 00	13
Figure 3	General troubleshooting chart	51



# 1 INTRODUCTION

The S/5 Light Monitor is a portable factory configured compact monitor designed for stationary and mobile indoor monitoring of a patient's vital signs. The monitor is available in two configurations; F-LM1 and F-LMP1. The difference between the configurations is illustrated in [table 1](#). Additionally, the monitor can be equipped with an optional recorder and battery module. An external power adapter is provided for power supply. The Light Monitor has also data card option and Ethernet interface which enables connecting the monitor to the network for remote monitoring the patient and data collection.



**Figure 1** S/5 Light Monitor with battery module and power adapter

**Table 1** Basic parameter configurations

	Parameters				
	ECGR	NIBP	SpO <sub>2</sub>	TEMP	InvBP
<b>F-LM1</b>	•	•	•	1 <sup>1)</sup>	-
<b>F-LMP1</b>	•	•	•	1 <sup>1)</sup>	2 <sup>1)</sup>

<sup>1)</sup> number of channels

Parameter explanations:

<b>ECGR</b>	ECG and respiration
<b>NIBP</b>	Non-invasive blood pressure
<b>SpO<sub>2</sub></b>	Pulse oximetry
<b>TEMP</b>	Temperature
<b>InvBP</b>	Invasive blood pressure

The following factory configurable parameters and functions are available:

- **N-LNET**; Network option
- **N-LDATA**; DataCard option
- **N-LDNET**; Network and DataCard options
- **N-LCM**; Mainstream CO<sub>2</sub> option
- **N-LNSAT**; Nellcor SpO<sub>2</sub> measurement

To all monitors following options are available:

- **N-LREC**; Thermal printer
- **N-LPOW**; External power supply, input: 110/230 VAC
- **N-LPOWT**; Vehicle power supply, input: 12...32 VDC
- **F-LBAT**; Battery Module w/ two batteries
- **N-LCHGR**; External battery charger w/ two batteries
- **N-LBB**; Rechargeable built-in backup battery

## 1.1 Notes to the reader

Datex-Ohmeda reserves the right to make changes in product specifications without prior notice. The information in this manual is believed to be accurate and reliable; however, the manufacturer assumes no responsibility for its use.

Datex-Ohmeda assumes no responsibility for the use or reliability of its software on equipment that is not furnished by Datex-Ohmeda.

### 1.1.1 Intended purpose

Datex-Ohmeda Light Monitor is intended for stationary and mobile monitoring of patient's ECG, SpO<sub>2</sub>, non-invasive and invasive blood pressure, temperature, respiration and CO<sub>2</sub> in hospitals and ambulances. When used outdoors, the monitor must be in the protective case.

The monitor is intended for use by qualified medical personnel only.

The Light Monitor is intended for patients with weight from 5 kg (11 lb.) up.

### 1.1.2 Trademarks

ComWheel, Datex-Ohmeda S/5, Datex-Ohmeda AS/3, Datex-Ohmeda CS/3, Light, EarSat, FingerSat and Flexlite are trademarks of Instrumentarium Corp.

### 1.1.3 Copyright

© Datex-Ohmeda Division, Instrumentarium Corp., 1996. All rights reserved. Printed in Finland.

The manual is protected by copyright. No part of this document may be photocopied, reproduced, or translated to another language without the prior written consent of Datex-Ohmeda.

## 1.2 About this manual

This technical reference manual is intended for service personnel who will perform service and maintenance procedures on the Light Monitor.

This technical reference manual is divided into two parts:

- **Part I** contains a general description of the monitor and service procedures.
- **Part II** contains detailed descriptions of the component parts of the monitor.

## 1.3 Related documents

### S/5 Light Monitor User's Reference Manual

The User's Reference Manual provides detailed instructions and references for the operation and configuration of the monitor. Everyday service, maintenance procedures and troubleshooting hints are also included.

### Light Monitor Schematic Diagrams

The Schematic Diagrams provide schematic diagrams and part layouts for the monitor.

### Patient Monitor Supplies and Accessories

The Patient Monitor Supplies and Accessories Catalogue provides information on all supplies and accessories available for the monitor.

## 1.4 Installation

### 1.4.1 Choosing the location

The monitor can be placed on a flat surface or hung with the handle from the bed or wall rails. Make sure that the surface or rail holds up to at least 10 kg/22 lb.

**WARNING** The monitor or its components should not be used adjacent to or stacked with other equipment. If adjacent or stacked use is necessary, the monitor and its components should be observed to verify normal operation in the configuration in which it will be used.

When choosing the location, refer to the appendix C later in this document.

## 1.5 Symbols

### 1.5.1 Symbols on equipment



on the rear panel indicates the warning:

Attention, consult accompanying documents.

Electric shock hazard. Do not open monitor frame. Refer servicing to qualified personnel.  
Do not touch any part of monitor or patient connections during defibrillation procedure.  
Disconnect power supply before servicing.

on the rear panel dust filter indicates the reminder:

Check rear panel dust filter regularly, and clean at least once a month.

on the patient connector panel indicates the cautions:

Use only the specified cables and accessories.  
Ensure proper contact of the return electrode of the electrosurgery unit to your patient to avoid possible burns at ECG electrode or other probe sites.

on the external power adapter indicates the cautions:

For continued protection against fire hazard, replace only with same type and rating of fuse.

Make sure voltage selector is set according to local voltage.

For indoor use only. For patient transport outdoors use the monitor in protective case and battery powered.

Do not immerse in liquid or allow any liquid to enter the interior.

on the battery unit indicates the warnings and cautions:

Do not put in fire.

Do not short-circuit any terminals.

Do not disassemble or mutilate.

Use only with Battery Module or External Battery Charger.

Discharge and charge batteries fully in every 3 months to restore full capacity.

Sealed NiCd battery must be recycled or disposed of properly. Discharge before disposing.

on the CPU board indicates the caution:

There is a lithium battery on the CPU board. Discard useless battery according to local regulations.



SpO<sub>2</sub>: Type BF (IEC-60601-1) protection against electrical shock, not defibrillation proof.



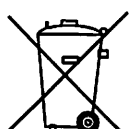
T<sub>1</sub>: Type CF (IEC-60601-1) protection against electrical shock, not defibrillation proof.



NIBP: Type BF (IEC-60601-1) defibrillator-proof protection against electrical shock.



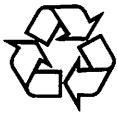
ECG, P<sub>1</sub>, P<sub>2</sub>: Type CF (IEC-60601-1) defibrillator-proof protection against electrical shock.



**Ni-Cd**

Battery packs contain heavy metal cadmium (chemical symbol Cd) and, in case of disposal, must be separated from other waste according to local regulations.





Battery packs contain Ni-Cd and they can be recycled.

**Ni-Cd**



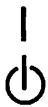
Protective earth terminal



Power input



Power output



Power ON/STANDBY



Alternating current



Direct current

IPX-class:

Degree of protection against harmful ingress of water as detailed in the IEC 60529:

IPX0

- ordinary equipment

IPX1

- vertically falling water drops shall have no harmful effects.

IPX4

- splash proof

SN, S/N

Serial number



Battery charging LEDs: LEDs will blink while batteries are being charged, and will stay illuminated when batteries are fully charged and the monitor is connected to mains.



The monitor is connected to the network (optional).



The DataCard (option) is inserted. If symbol is blinking the card is faulty, or it is not inserted properly.



Ethernet connectors



Printer connector



ESD warning symbol for electrostatic sensitive devices. Pins of connectors identified with the ESD warning symbol should not be touched. Connections should not be made to these connectors unless ESD precautionary procedures are used. See "Safety precautions: ESD precautionary procedures" in the User's Reference Manual for details.



Symbol for non-ionizing electromagnetic radiation. Interference may occur in the vicinity of equipment marked with this symbol.

### 1.5.2 Symbols on transport packaging



The contents of the transport package are fragile and have to be handled with care.



This symbol indicates the correct upright position of the transport package.



The transport package must be kept in a dry environment.



This symbol is to indicate the temperature limitations within which the transport package should be kept and handled.

## 2 SAFETY

### 2.1 Equipment classification

#### 2.1.1 Classification according to IEC 60601-1

- CLASS I EQUIPMENT and INTERNALLY POWERED EQUIPMENT according to the type of protection against electrical shock.
- TYPE BF or CF equipment according to the degree of protection against electric shock is indicated by a symbol beside each patient connector.
- Degree of protection against harmful ingress of water as detailed in the IEC 60529:  
Monitor: IPX1, vertically falling water drops shall have no harmful effects (applicable when the monitor is in upright position, or tilted backwards). In the protective case IPX4, splash proof, only when the case is closed properly, the monitor is intact and operates on battery power.  
Power adapter: IPX0, ordinary equipment.  
Power adapter for Transport Vehicles: IPX1.
- EQUIPMENT not suitable for use in the presence of a FLAMMABLE ANAESTHETIC MIXTURE with air or with oxygen or nitrous oxide.
- CONTINUOUS OPERATION according to the mode of operation.
- CISPR: Group 1, Class A.  
Group 1 contains all ISM (Industrial, scientific and medical) equipment in which there is intentionally generated and/or used conductively coupled radio-frequency energy which is necessary for the internal functioning of the equipment itself.  
Class A equipment is suitable for use in all establishments other than domestic and those directly connected to the public low-voltage power supply network that supplies buildings used for domestic purposes.

#### 2.1.2 Classification according to EU Medical Device Directive

- The monitor is classified as IIb.

#### 2.1.3 Responsibility of the manufacturer

Instrumentarium Corp. is responsible for the effects of safety, reliability and performance of the equipment only if:

- assembly, operations, extensions, readjustments, modifications, service and repairs are carried out by authorized personnel
- the electrical installation of the relevant room complies with appropriate requirements
- the equipment is used in accordance with the User's Reference Manual and serviced and maintained in accordance with the Technical Reference Manual.

The CO<sub>2</sub> measuring option (N-LCM) is manufactured for Instrumentarium Corp. by Pryon Corp., 8500 S.W. Creekside Place, Beaverton, OR 97008-7107.

The Nellcor option (N-LNSAT) is manufactured for Instrumentarium Corp. by Mallinckrodt Inc., 675 McDonnell Boulevard, P.O. Box 5840, St. Louis, MO 63134 USA.

## 2.2 Safety precautions

### 2.2.1 Warnings

**WARNING** indicates situations in which the user or the patient may be in danger of injury or death.

#### Explosion hazard

- Do not use the monitor in presence of flammable anesthetics.

#### Electrical shock hazard

- Use only hospital grade grounded electrical outlets and power cord. Grounding reliability can only be achieved when the equipment is connected to a receptacle marked 'hospital grade'.
- Do not remove cover. Refer servicing to qualified service personnel.
- Avoid any conductive contact to the probes and sensors.
- Disconnect the monitor from the electrical outlet before cleaning. Let it dry completely before reconnecting it to the electrical outlet.
- Do not autoclave any part of the monitor with steam or ethylene oxide. Do not immerse in liquid or allow liquid to enter the interior of any part.
- Make sure that external equipment is hospital grade grounded before connecting it to the monitor.
- When connecting external equipment to the monitor, make sure that the whole combination complies with safety standard IEC 601-1-1 for the medical electrical systems and with the requirements of local authorities.  
Non-medical electrical equipment connected to the monitor shall be supplied from an extra isolating transformer which has a protectively earthed outlet.
- Do not leave loose any sensor cables connected to patient. Either connect them to the monitor or detach them from the patient.
- Do not use the monitor, any parts thereof or any accessories, if they have become wet or exposed to liquid.
- Where the integrity of the external protective conductor installation or arrangement is in doubt, equipment shall be operated from its internal power source.

#### Patient safety

- Always make sure that necessary alarm limits are set and operative when you start monitoring.
- When the alarms are suppressed, observe the patient frequently.
- Connect only one patient to one monitor at a time.
- Constant attention by a qualified professional is needed whenever a patient is under anesthesia or connected to a ventilator. Some equipment malfunctions may pass unnoticed in spite of the monitor alarm.

- Do not use antistatic or electrically conductive breathing tubes. They may increase the risk of burns when electrosurgery unit is utilized.
- Do not use the monitor during magnetic resonance imaging (MRI).
- ECG, Impedance Respiration, InvBP: Ensure proper contact of the return electrode of the electrosurgery unit to your patient to avoid possible burns at sensor sites.
- ECG, Impedance Respiration, InvBP: Make sure that no part of the patient connections touches any electrically conductive material including earth.
- Impedance Respiration: In obstructive apnea, thoracic movements and impedance variations may continue.
- NIBP: The monitor sets the inflation pressure automatically according to the first measurement. Reset the case to reset the inflation limit before measuring a new patient.
- PATIENTS WITH PACEMAKERS OR ARRHYTHMIAS: Monitor may count the pacemaker pulses as heart beats during cardiac arrest, some arrhythmias, and with certain types of pacemakers particularly in ON R mode. Do not rely entirely upon rate meter alarms. Keep patients with pacemakers and arrhythmias under close surveillance.
- PACEMAKER PATIENTS: The impedance respiration measurement may cause rate changes in Minute Ventilation Rate Responsive Pacemakers. Set the pacemaker rate responsive mode off or turn the impedance respiration measurement off on the monitor.
- SpO<sub>2</sub>: A damaged sensor, or a sensor soaked in liquid, may cause burns during electrosurgery.
- SpO<sub>2</sub>: Change measuring site frequently. Change sensor site and check skin and circulatory status every 2-4 hours with adults, and every hour with small children.
- The output signals are not floating and they must not be connected directly to a patient.
- Do not use delayed signals for defibrillator synchronization.
- The monitor is intended for use by qualified medical personnel only.
- InvBP: All invasive procedures involve risks to the patient. Use aseptic technique. Follow catheter manufacturer's instructions.
- The monitor or its components should not be used adjacent to or stacked with other equipment. If adjacent or stacked use is necessary, the monitor and its components should be observed to verify normal operation in the configuration in which it will be used.

**WARNING Use only approved accessories, mounts and defibrillator-proof cables and invasive pressure transducers. For a list of approved supplies and accessories, see the "Supplies and Accessories" catalog. Other cables, transducers and accessories may cause a safety hazard, damage the equipment or system, result in increased emissions or decreased immunity of the equipment or system or interfere with the measurement. Protection against cardiac defibrillator discharge is due in part to the accessories for pulse oximetry (SpO<sub>2</sub>), temperature (T) and invasive pressure (P) measurement. Single-use accessories are not designed to be re-used. Re-use may cause a risk of contamination and affect the measurement accuracy.**

## Service

- Only trained personnel with proper tools and test equipment should perform the tests and repairs described in this manual. Unauthorized service may void the monitor warranty.
- Switch the power off, unplug the power cord, and remove the batteries before service.
- The monitor is always energized with 12 V when the batteries are connected, even though the power cord is removed and ON/STBY switch is in STBY position.
- Do not touch any exposed wire or conductive surface while covers are off and the monitor is energized. The voltages present can cause injury or death.
- Electrostatic discharge through the PC boards may damage the components. Before replacing PC boards, wear a static control wrist strap. Handle all PC boards by their non-conductive edges and use anti static containers when transporting them.
- Do not break or bypass the patient isolation barrier when testing LM-STP and LM-ECG boards.
- Do not perform any testing or maintenance on the monitor while they are being used on a patient.
- There are special components used in this monitor, which are vital to assure reliability and safety. Datex-Ohmeda assumes no responsibility for damage if replacement components not approved by Datex-Ohmeda are used.
- Replace the fuse with a fuse of the same type and the same rating.
- Perform electrical safety checks and current leakage tests to the monitor after service.

## 2.2.2 Cautions

**CAUTION** indicates situations in which the unit or devices connected to it may be damaged.

- Use licensed patient cables and accessories only, see Datex-Ohmeda Catalogue Patient Monitor supplies and accessories. Other cables and accessories may damage the system or interfere with measurement.
- Before connecting power cord, ensure that the input voltage selector is set correctly in the external power adapter.
- Use the monitor outdoors with the battery power only.
- Do not store the monitor beyond the specified temperature range.
- Do not use hypochlorite, ammonia-, phenol- or acetone-based cleaners. They may damage the monitor.
- Clean rear panel fan dust filter once a month or whenever needed.
- Leave space around the monitor for ventilation to prevent the monitor from overheating.
- Do not apply pressurized air to any outlet, or tubing connected to the monitor. Pressure may destroy sensitive elements.
- When used in moving vehicle mount the monitor properly.
- Dispose of the device and parts thereof in accordance with local regulations.
- Vibrations during transport may disturb SpO<sub>2</sub>, ECG, impedance respiration and NIBP measurements.
- CO<sub>2</sub>, SpO<sub>2</sub>: Do not apply force to sensors or sensor cables.
- CO<sub>2</sub>: Do not force the water-trap into place.
- DataCards: Do not subject cards to excessive heat, bending, or magnetic fields.
- InvBP: Mechanical shock to invasive blood pressure transducer may cause severe shifts in zero balance and calibration, and produce erroneous readings.

### Battery cautions

- Do not put in fire.
- Do not short-circuit any terminals
- Do not use damaged or leaking batteries.
- Do not disassemble or break the batteries.
- Use only with Battery Module.
- Charge and discharge batteries fully once in three months to restore full capacity.
- Sealed NiCd battery must be recycled or disposed properly. Discharge before disposing.

### Points to note

Medical electrical equipment needs special precautions regarding electromagnetic compatibility and needs to be installed and put into service by qualified personnel according to the electromagnetic compatibility information provided in the Appendix C.

Portable and mobile RF communications equipment can affect the medical electrical equipment.

Service and reparations are allowed for authorized service personnel only.

## **2.3 Safety test**

Measure leakage current according to following procedures:

- Connect the GND electrode of the test device to the body of the 9-pin D-connector of the Light Monitor. The nuts that are for locking the male cable connector can be used as well.



### 3 ARCHITECTURE

The Light Monitor is a compact patient monitor with fixed configuration. The monitor is designed for stationary and mobile indoor monitoring of a patient's vital signs. The monitor can be equipped with an optional recorder and battery module. An external power adapter is provided for power supply.

#### 3.1 Monitor structure

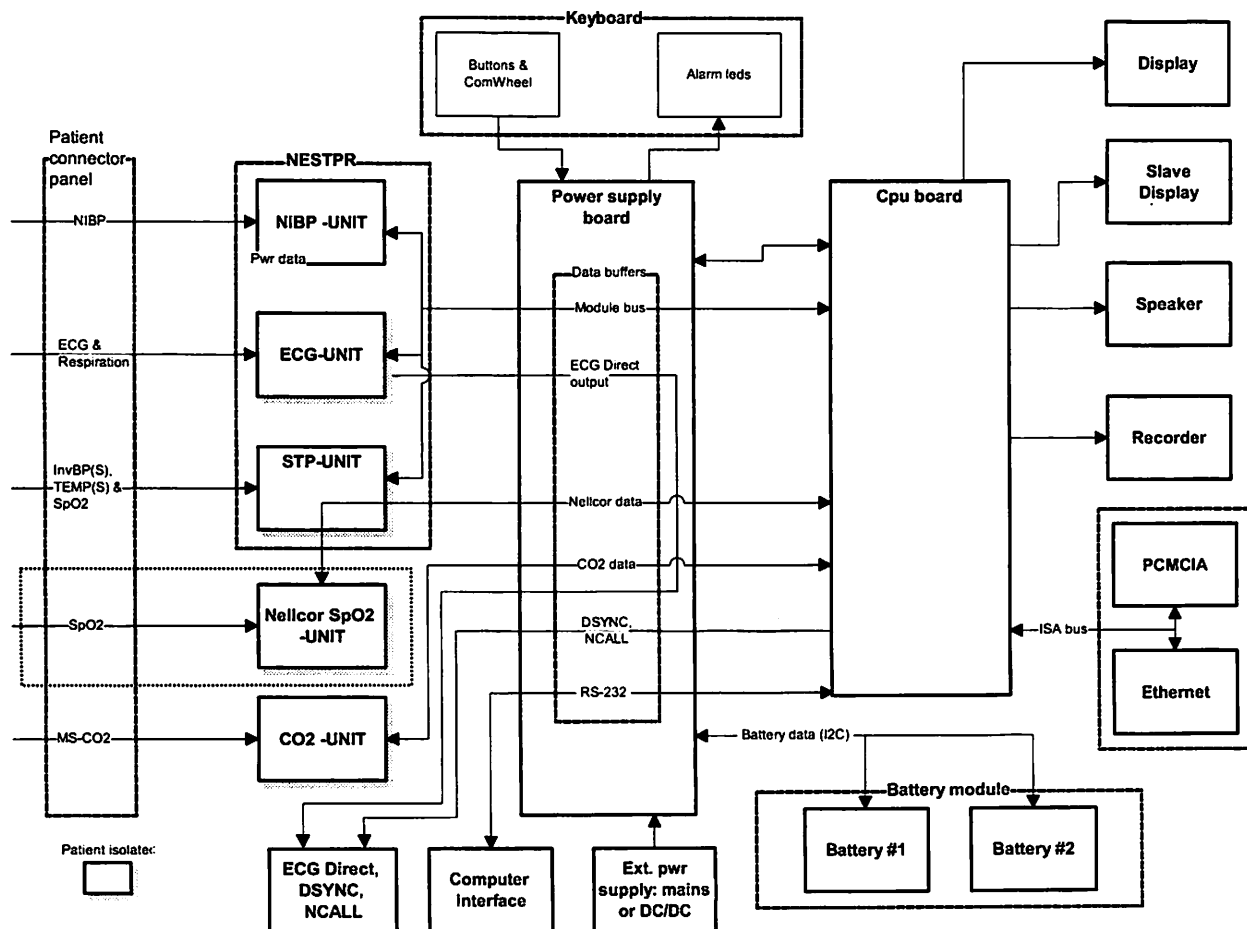


Figure 2 Main block diagram of Light Monitor, revision 00

The monitor can be divided to the following parts:

1. **CPU board**  
The CPU board controls display and slave display, loudspeaker and recorder according the data collected from the other units.
2. **STP - unit**  
The STP-unit is a parameter board that measures invasive blood pressure(s), body temperature and oxygen saturation of the blood (SpO2).
3. **ECG -unit**  
The ECG-unit is a parameter board that measures 3-lead ECG.

4. **NIBP-unit**  
The NIBP-unit is a parameter board that measures non-invasive blood pressure.
5. **CO<sub>2</sub> -unit**  
The CO<sub>2</sub>-unit measures carbon dioxide concentration of the respiration gases. Measurement is performed by an OEM product manufactured by Pryon Corp.
6. **Nellcor compatible SpO<sub>2</sub> -unit**  
The SpO<sub>2</sub>-unit measures oxygen saturation of the blood. Measurement is performed by an OEM product manufactured by Nellcor-PB. This is optional with on-board SpO<sub>2</sub> measurement in the STP-unit.
7. **Network unit**  
The unit enables connecting the Light Monitor to the network for remote monitoring the patient and data collection.
8. **Memory unit**  
The memory unit is an optional data storage module. It is used for storing patient related physiological data by removable PC-card.
9. **Power supply board**  
Board delivers power from one of the power sources, external power supply or one of the two batteries. The other operations are:
  - battery management: secondary battery charge/discharge control and capacity gauge
  - keyboard and ComWheel reading
  - alarm and charge led control/drive
  - buffering serial communication
10. **Display**  
The display is VGA compatible 9" high-resolution electroluminescent (EL) flat panel display. The resolution is 600 x 400 pixels.
11. **Printer**  
The built-in thermal printer provides a real time waveform printing, numerical data and trend data printout up to 24 hours.
12. **Battery module**  
Two rechargeable and removable secondary batteries are located in the separate battery module.
13. **Keyboard and Comwheel**  
Keyboard and ComWheel actions are read by the power supply board.
14. **Backup Battery**  
Built-in NiCd battery is located inside the monitor. It provides typically up to 30 min operation time to the monitor.

## 3.2 Power supply unit

The power supply board functions can be summarized as follows:

- Charge the batteries.
- Choose between battery and mains operation.
- Distribute power to the CPU, CO<sub>2</sub>, STP, ECG, and NIBP boards.
- Control the alarm LEDs.
- Read the input from the keyboard and ComWheel.

The CPU, CO<sub>2</sub>, STP, ECG, and NIBP boards are connected to the power supply board for centrally distributed power. Thus all signals transmitted between these boards are transmitted via the power supply board. The power supply board controls the reset of the CPU board via the startup key.

## 3.3 CPU

The CPU board functions can be summarized as follows:

- Process the data transmitted from the CO<sub>2</sub>, STP, ECG, NIBP and power supply boards.
- Control the CO<sub>2</sub>, STP, ECG, and NIBP boards.
- Control the display, loudspeaker and recorder.
- Generate alarm signals.
- Generate nurse call signal.

The display, the loudspeaker and the recorder, are all connected directly to the CPU board. The CPU board includes the circuitry required to control these units. The CPU board communicates with the power supply board over a 9600 baud serial communication channel. The ESTP and NIBP boards are connected to the CPU board via the power supply board. The CPU board communicates with these boards over a 500 kbaud serial communications channel. The reset of the ESTP and NIBP boards are controlled separately.

The CPU board generates a nurse call signal in the event of an alarm situation. The signal is transmitted via the power supply board to the serial I/O connector on the monitor rear panel.

### 3.4 NIBP unit

The NIBP unit consists of the NIBP board, an air pump, and pneumatic valves. The NIBP board functions can be summarized as follows:

- Control the function of the air pump and the pneumatic valves.
- Measure the pressure variation of the NIBP cuff.

The pressure variation of the NIBP cuff is analyzed on the NIBP board and transmitted to the CPU board over a serial communication channel.

### 3.5 ECG unit

The ESTP board functions can be summarized as follows:

- Measure ECG
- Generate defibrillation synchronization signal

The ECG signal is monitored and analyzed on the ECG board and transmitted to the CPU board over a serial communication channel.

The ECG board is electrically patient isolated. The operating voltage 10...16 V is generated from the + 12 V received from the power supply board. The ECG board is reset by the CPU board.

The ECG board generates a defibrillation synchronization signal. The signal is transmitted via the CPU and power supply board to the serial I/O connector on the monitor rear panel. The defibrillation synchronization signal is available also on the patient connector on the patient connector panel.

### 3.6 STP unit

The STP board functions can be summarized as follows:

- Measure SpO<sub>2</sub>, temperature and invasive blood pressure.

The signals from the parameters being monitored are analyzed on the STP board and transmitted to the CPU board over a serial communication channel.

The STP board is patient isolated. The operating voltage is generated from the +12 V voltage received from the power supply board. The STP board is reset by the CPU board.

### 3.7 CO<sub>2</sub> unit

The CO<sub>2</sub> unit consists of the CO<sub>2</sub> board, an isolated power supply, and a pump. The CO<sub>2</sub> board functions can be summarized as follows:

- Process the CO<sub>2</sub> waveform generated by the mainstream CO<sub>2</sub> sensor.
- Generate end tidal and inspiratory CO<sub>2</sub> values, and breaths per minute data.
- Control the Mainstream CO<sub>2</sub> sensor motor and heater.

The waveform data is processed on the CO<sub>2</sub> board and transmitted to the CPU board over a serial communication channel.

## 3.8 Display unit

The display unit consists of an electroluminescence display with 640 × 400 resolution, a power converter and control logic. The unit is equipped with a protective plate. The unit is directly connected to the CPU board.

### 3.8.1 Slave display

Internal VGA compatible display controller with 640 × 480 resolution. The slave display can be connected to external VGA connector, X7.

## 3.9 Power adapters

### 3.9.1 N-LPOW

The external power adapter **N-LPOW** is connected to the power connector on the monitor rear panel. The adapter includes a switch for the voltage range and a LED indicating energization. The power adapter supplies 12.5 V to operate the monitor and 18.5 V to charge the batteries. Fuses are located on the primary side of the adapter for overvoltage protection. See the part II/7 for more information.

### 3.9.2 N-LPOWT

Power adapter for transport vehicles, **N-LPOWT**, is designed to provide the Light Monitor with electric power in medical transport vehicle environment and ensure battery charging. See the part II/7 for more information.

## 3.10 Host serial communications

### 3.10.1 Module bus

The module bus is a asynchronous, CMOS-level serial communication between host processor and Datex-Ohmeda -based parameter modules and CO<sub>2</sub> measurement by Pryon. Only TXDM and RXDM signals are used. The TXDM signal is module bus transmit line from host to modules and the RXDM signal is a receive line from modules to host. Modules are wired-OR connected to RXDM line.

The module communication link is also provided in the D15 male connector on rear panel.

### 3.10.2 Computer interface (RS-232)

The computer interface is a asynchronous, RS-232-level serial communication between the Light Monitor and external device e.g. PC. External device is connected to the D15 male connector on rear panel.

### **3.10.3 CO<sub>2</sub> module**

The CO<sub>2</sub> module, manufactured by Pryon Corp, is used in the Light Monitor for CO<sub>2</sub> mainstream measurement. Communication with the host is provided by an asynchronous serial link. Signals used in the communication are TXDC, RXDC. The TXDC signal is transmit line from host to CO<sub>2</sub> module and the RXDC signal is a receive line from CO<sub>2</sub> module to host.

### **3.10.4 Nellcor compatible SpO<sub>2</sub> -module**

A Nellcor compatible SpO<sub>2</sub> measurement unit communicates with the host by a asynchronous serial link. Signals used are TXDS, RXDS and CTSS#. The TXDS signal is transmit line from host to SpO<sub>2</sub> module and the RXDS signal is a receive line from SpO<sub>2</sub> unit to host. The CTSS# signal allows host to suspend transmission from the module if needed.

### **3.10.5 Power board**

Host communicates with the power board on an asynchronous serial link. TXDP and RXDP signals are used. The TXDP signal is transmit line from host to power board and the RXDP signal is a receive line from power board to host.

### **3.10.6 Recorder**

The host sends data to the printer via asynchronous serial link. TXDR, RXDR, CTSR and RTSR signals are used. The TXDR signal is transmit line from host to recorder and the RXDR signal is a receive line from recorder to host CTSR and RTSR lines are used for hand-shaking.

## 4 CLEANING

Before cleaning:

- Turn the power to Standby
- Disconnect the power cord from the mains power supply

After cleaning:

- Let dry completely
- Reconnect the power cord and turn the power ON

<b>CLEANING CASING / SURFACE when needed</b>	<b>CLEANING DUST FILTER at least once a month</b>	<b>CLEANING PATIENT ACCESSORIES</b>
Wipe gently with a cloth, moistured with a mild detergent.  Let dry completely before reconnecting the power cord.	Pull out the filter frame on the rear panel. Do not remove any screws!  Shake the filter and blow out the dust.  If the filter is damaged, replace it with a new one (p/n 888260).	See the instructions delivered with the accessory.
<b>PERMITTED CLEANERS</b>	<b>PERMITTED DISINFECTANTS</b>	<b>NOT ALLOWED</b>
Datex-Ohmeda cleaning fluid  Other mild detergents	Ethanol  Isopropyl alcohol  Chlorite compounds  Glutaraldehyde	Do not use Hypochlorite, acetone-, phenol- or ammonia based cleaners.  Do not autoclave the device.  Do not immerse the device in liquids or allow liquids to enter the interior of any part.

For more detailed information see User's Reference Manual.





## 5 FUNCTIONAL CHECK


These instructions include complete procedures for **functional check (FC)** for Datex-Ohmeda Light monitors. The functional check is recommended to be performed after monitor installation and after long storage.

The first part of the instructions contain check procedures that are done through the service menu. These checks are especially recommended if the monitor has been stored for a long time without using it.

When installing a new monitor the **performance checks** with a simulator and accessories are typically enough to ensure the correct function of the monitor. We recommend however always performing the complete check to confirm that no hardware failures occurred during transportation.

The instructions are planned for the maximum functional configuration. Perform the procedures in the ascending order and skip the items that do not correspond to your monitor configuration.

The instructions include a **check form** (Appendix A) to be filled in when performing the corresponding procedures.

The symbol  in the instructions means that the performed procedure should be signed in the check list.

All menu selections related to  Datex-Ohmeda products are written in following typeface:

**Monitor Setup - Install/Service** (password 16-4-34) -  
**Service** (password 26-23-8) - **Modules - ESTP - ECG**

Menu selections related to other products e.g. simulators are written in following typeface:

RESP - WAVE - NORM  
- RATE - 20

### Recommended tools:

Tool	Order No.
Simulator capable of simulating ECG, RESP and invBP	-
SpO <sub>2</sub> finger probe	SAS-F4
Adult NIBP cuff	572435
Adult NIBP hose	877235
MemCard- Data(only for monitors with data card option)	
Temperature test plug set	884515
Mainstream CO <sub>2</sub> sensor (only for monitors with CO <sub>2</sub> option)	902300
Mainstream CO <sub>2</sub> airway adapter (only for monitors with CO <sub>2</sub> option)	902301/902302/902303

## 5.1 General functional inspection

1. Connect the power cord to the power adapter and the power adapter cable to the Light Monitor.  
Check that the green LED turns on in the power adapter and the LED on the lower right-hand corner of the monitor turns on or starts flashing.  
If the monitor contains a battery module, check that both battery charge status LEDs turn on or start flashing.
  
2. Switch the monitor on. Check that the monitor starts up properly, i.e.
  - both alarm LED's turn on and off
  - the fan starts running
  - the start-up sound is heard from the loudspeaker
  - the normal monitoring screen appears
  - no error messages appear onto the screen \*)
  - If the monitor contains a recorder, two lines of start-up information should be recorded
  - check that the time and date are correct, adjust if necessary
  - if the monitor contains a F-LBAT or N-LBB check that the battery symbol is displayed

\*) NOTE: "Check network connectors" will appear if the N-LNET or N-LDNET option is installed.

3. Check the loudspeaker by adjusting the alarm volume in the **Alarms Setup** menu:

Press the **Menu** button.

Select **Alarms Setup - Alarm Volume**

Test the whole volume scale from 1 to 10 by turning the ComWheel and check that the alarm volume changes correspondingly. The alarm sound should be clear and audible at all settings.

Select **Main Menu**

4. Select **Service View - Keyboard - Dummy Press**.  
Press the function keys one by one. Check that each key generates a sound from the loudspeaker and the corresponding text.
  
5. Check that the time and date are correct, adjust if necessary.

Select **Monitor Setup - Set Time and Date**

NOTE: You cannot change the monitor's time settings after a case has started. This prevents losing the trend data.

NOTE: If the clock shows time 0:00 continuously after start-ups, the SRAM/Timekeeper's battery on the CPU board needs to be replaced.

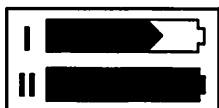
Return to **Main Menu** by selecting **Previous Menu - Main Menu**

6. Check the battery (If F-LBAT or N-LBB option included):

Disconnect the power cord (without switching the monitor to standby).

Check that the monitor continues to run normally with battery. The battery indicator should appear onto the upper right hand corner of the screen:

Reconnect the power cord and check that during charging, the charging symbol is displayed and the Battery charge status LED starts flashing:



### 5.1.1 Recorder test

7. Open the paper compartment cover. Check that the message "Recorder: Cover open" appears on the screen, then close the cover.

8. Select **Main Menu - Record/Print- Record Wave** and check that the recorder starts recording. Select **Stop Wave** to stop recording. Check that the quality of the recordings is acceptable.




### 5.1.2 PCMCIA card test

9. Insert the Memory card labeled "Data" in the DataCard slot. Check that the message "Data Card inserted" appears onto the message field and the white data card symbol on the upper right hand corner of the screen appears within one minute.



### 5.1.3 Network test

12. Connect the Mon-Net cable and the Identification plug to the monitor
13. Check that the monitor connects to the Datex-Ohmeda Network, i.e. the network symbol  is displayed on the upper right-hand corner of the screen.

A message regarding the connection to Datex-Ohmeda Information Center should appear in the message field on the screen.

14. Press the **Menu** button to enter the **Network** service menu:

**Monitor Setup - Install/Service** (Password 16-4-34) -  
**Service View** (Password 26-23-8) - **Monitor - Communication**

Check that:

- the "location ID number" matches with the ID plug connected to X3
- the packets and bytes IN is increasing slowly
- the packets and bytes OUT is increasing quickly.
- the "connections" shows the names of the connected networks
- the counters for data errors ("CRC", "Frame", "Transm.") are stable

NOTE: The counters may show values greater than 0. However, any values increasing continuously indicates a problem.

15. Check that the counters for hardware errors ("Intern.", "Missed", "FIFO", "Overrun") all show 0. If any of the counters show a value greater than 0, it indicates a problem on the CPU board.

Return to the **Monitor Setup** menu by selecting **Previous Menu** repeatedly.



### 5.1.4 ECG board tests

16. Enter the **ESTP : ECG** service menu:

Press the **Menu** button and select:

**Monitor Setup - Install/Service** (Password 16-4-34) -

**Service View** (Password 26-23-8) - **Modules - ESTP : ECG**

Check from the Service Data that:

- the "Timeouts", "Bad checksums" and "Bad c-s by mod" values are not increasing faster than by 50 per second.
  - the ECG/RESP board memories have passed the internal memory test, i.e. "RAM", "ROM" and "EEPROM" all state **OK**.
17. Check that the module mains power frequency "Power Freq" value has been set according to the supply frequency. If necessary change the setting by selecting **Power Freq**.
18. Check that the "Resp Available" and "Resp measurement" both show **ON**.

NOTE: The Resp measurement shows **OFF**, if **Resp** is not selected to the screen setup. To setup the screen, press the **Menu** key and select: **Monitor Setup - Waveform Fields or Digit Fields**.



### 5.1.5 STP board tests

19. Enter the **ESTP : STP** service menu:

- Check that the "Timeouts", "Bad checksums" and "Bad c-s by mod" values are not increasing faster than by 50 per second.
  - Check that the STP board memories have passed the internal memory test, i.e. "RAM", "ROM" and "EEPROM" all show OK.
20. Check that the protection for temperature calibration is on:

"Protect key" text in the menu should state **OFF**

"Protect mode" text should state **ON**.

If necessary change the protection mode in the **Calibrations** menu.



### 5.1.6 NIBP board test

21. Enter the **NIBP** service menu:

Check that the "Timeouts", "Bad checksums" and "Bad c-s by mod" values are not increasing faster than by 50 per second.

Check that the NIBP board memories have passed the internal memory test, i.e. "RAM", "ROM" and "EEPROM" all show **OK**.



### 5.1.7 Mainstream CO<sub>2</sub> test

19. Enter the **CO2** service menu:

Press the **Menu** button and select:

**Monitor Setup - Install/Service** (Password 16-4-34) -

**Service View** (Password 26-23-8) - **Modules - CO2**

Check from the Service Data that: "Timeouts", "Bad checksums" and "send queue full" values are not increasing faster than by 50 per second.

A value increasing faster than this indicates a failure in Module Bus communication.



## 5.2 Performance checks

1. Connect a 5-lead cable to the monitor. Configure the monitor screen so that all parameter information is displayed, for example for the maximum configuration:

Press the **Menu** button to enter the **Main Menu** and select:  
**Monitor Setup - Waveform Fields/Digit Fields**

<b>Waveform Fields</b>	<b>Digit Fields</b>
<b>Field 1 - ECG1</b>	<b>Field 1 -Temp</b>
<b>Field 2 - P1</b>	<b>Field 2 - NIBP</b>
<b>Field 3 - P2</b>	<b>Field 3 - Pleth</b>
<b>Field 4 - Resp</b>	<b>Field 4 - CO<sub>2</sub></b>

Return to **Normal Screen**.

Connect the patient simulator and check that all parameter information is displayed as configured on the screen.

NOTE: InvBP waveforms are not shown without a patient simulator.

Preset measurement settings for parameters, for example as follows:

**ECG & Resp - ECG Setup - HR Source - AUTO**  
 - Resp Setup - Size - 1.0  
 - Resp Rate Source - AUTO  
 - Detection Limit - AUTO

NOTE: The RESP waveform or Digit Field have to be selected on the screen before the respiration measurement can be turned on.

**NIBP & Inv. Press - P1 Setup&Alarm - Label - ART**  
 - P2 Setup&Alarm - Label - CVP

Press the **Menu** button to enter the **SpO2 & Temp** and select  
 - Pleth Scale - AUTO



2. Connect the patient simulator to the ECG and InvBP connectors, SpO<sub>2</sub> probe to the SpO<sub>2</sub> connector and temperature test plug to the Temp connector. Attach the SpO<sub>2</sub> probe on your finger and check that:
  - the simulated waveforms are good
  - the SpO<sub>2</sub> value is in expected range
  - the Pleth waveform is normal.



3. Set the InvBP simulator to +100 mmHg static pressure. Push the Zero All button and check that:
  - the InvBP waveforms set on the baseline
  - the digital values go to zero

Set the simulator to 0 mmHg and press **Zero All** button. After the monitor has completed the zeroing turn the simulator to dynamic mode and check that the waveform is normal.



4. Check that the message "No probe" is displayed when there is no SpO<sub>2</sub> sensor connected. Connect a SpO<sub>2</sub> finger probe to the monitor and check that the message "Probe off" is displayed when the probe is not connected to finger.



5. Attach the SpO<sub>2</sub> sensor to your finger and check that after the message "Pulse search" the pleth waveform is displayed and the SpO<sub>2</sub> value is in the expected range (95-99 %). Check that the HR value is calculated from SpO<sub>2</sub> when ECG and InvBP (P1) cables are not connected.



6. Remove the SpO<sub>2</sub> sensor from your finger and check that the message "Probe off" is displayed. Disconnect the sensor from the monitor and check that "No probe" message is displayed.



7. Attach an adult NIBP cuff onto your arm and perform one NIBP measurement. Check that the module identifies the cuff, i.e. the text "Adult" appears in the NIBP digit field for a short time.

Check that the module gives a reasonable measurement result.





8. Check that the message "No CO<sub>2</sub> sensor" is displayed when there is no CO<sub>2</sub> sensor connected. Connect a CO<sub>2</sub> sensor to the monitor and check that the message "warming" is displayed.



9. Wait until the "warming" message disappears and the CO<sub>2</sub> value appears to the screen. Breathe at least 5 times to the CO<sub>2</sub> sensor adapter and make sure that the measured values are reasonable and the Respiratory value is calculated.



Fill in all necessary documents.



## 6 SERVICE CHECK

### 6.1 General service information

Field service of the Light Monitor is limited to replacing faulty printed circuit boards or mechanical parts. Faulty printed circuit boards should be returned to Datex-Ohmeda for repair.

Datex-Ohmeda is always available for service advice. Please provide the unit serial number, full type designation, and a detailed description of the fault.

The instructions are planned for the maximum functional configuration. Perform the procedures in the ascending order and skip the items that do not correspond to your monitor configuration.

**CAUTION** Only trained personnel with appropriate equipment should perform the tests and repairs outlined in this section. Unauthorized service may void warranty of the unit.

### 6.2 Service check procedure

These instructions include complete procedures for service check. **The service check is recommended to be performed after any service repair**, however, the service check procedures can be used also for determining possible failures.


The procedures should be performed in ascending order.

The instructions include a **check form** (Appendix B) which should be filled in when performing the procedures.

Names of the keys are written in bold Helvetica typeface, for example **Normal Screen**.

Selectable menu items are written in bold and italic typeface, for example ***Previous Menu***.

Informative messages displayed on the screen are written in normal typeface, but separated with quotation mark, for example 'Please wait'.

The mark  in the instructions means that the performed procedure should be signed in the check form.

The procedures are designed for monitors with monitor software of level 894727-4.1. However, for the most part they apply to monitors with older monitor software as well.

#### Recommended tools

Tool	Order No.
Patient simulator for ECG, Impedance Resp and BP	-
Pressure manometer	-
Temperature test set	884515
3- and 5-lead ECG cable	-
SpO <sub>2</sub> finger probe	SAS-F4
InvBP transducer	-
Adult NIBP cuff	572435
Adult NIBP hose	877235
Infant NIBP hose	877514
Infant NIBP cuff	877407
Mainstream CO <sub>2</sub> sensor (only for monitors with	902300

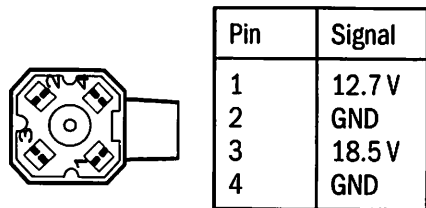
Tool	Order No.
CO2 option)	
Mainstream CO2 airway adapter (only for monitors with CO2 option)	902301/902302/ 902303
Screwdriver -Poizdrive- type	
MemCard- Data (only for monitors with data card option)	

**Recommended parts**

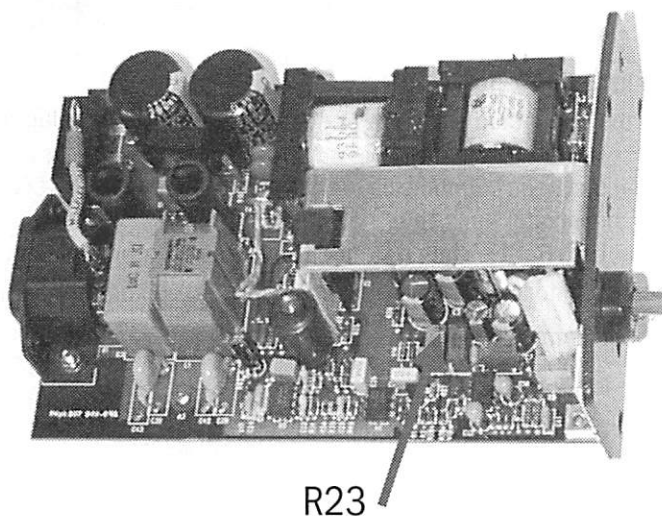
Part	Order No.	Notes
Fan filter	886841	
Recorder paper	74205	if N-LREC option installed

**6.2.1 Visual inspection**

- Switch the monitor to standby
  - Disconnect all the connection cables from the monitor's rear panel.
1. Check internal parts:
    - Make visual inspection for all external parts of the monitor. Check e.g. that the power cord receptacle is intact in the power adapter.
    - Connect the power cord to the power adapter and check the supply voltage from the power adapter's connector. PIN 1 voltage must be 12.7 V without load (Figure 1). If necessary adjust the 12.7 V with trimmer R23 (Figure 2).

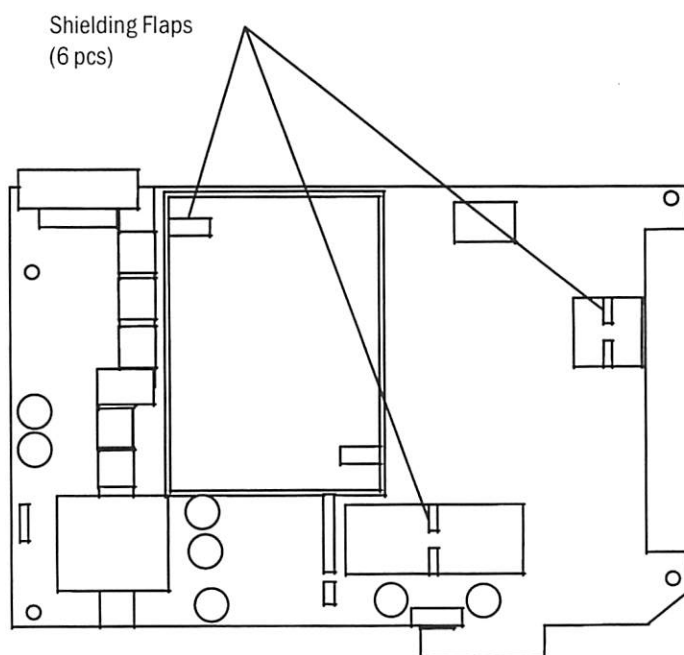


**Figure 1 Power adapter's voltages**



**Figure 2** Adjustment trimmer R23 in N-LPOW

- Clean or replace the fan filter.
- Clean the recorder unit, if necessary.
- Check that all shielding flaps (6 pcs) are properly closed. (Figure 3)



**Figure 3** LM1-STP board EMC covers

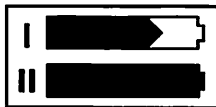


2. Check external parts:
  - the patient panel sticker is intact
  - all connectors are intact and are attached properly
  - both screws on the patient panel are tightened properly



3. General functional inspection

- Connect the power cord to the Power Adapter and the Power Adapter cable to the Light Monitor.  
Check that the green LED turns on in the power adapter and the LED on the lower right-hand corner of the monitor turns on or starts flashing.  
Check that both Battery charge status LEDs turn on or start flashing.
- Switch the monitor on. Check that the monitor starts up properly, i.e.
  - both alarm LED's turn on and off
  - the fan starts running
  - the start-up sound is heard from the loudspeaker
  - the normal monitoring screen appears
  - no error messages appear onto the screen \*)
  - if the monitor contains a recorder, two lines of start-up information should be recorded
  - check that the time and date are correct, adjust if necessary
  - if the monitor contains a F-LBAT or N-LBB check that the battery symbol is displayed:



\*) NOTE: "Check network connectors" will appear if the N-LNET or N-LDNET option is installed.

- Enter the service menu and select Dummy Press.  
Press the function keys one by one. Check that each key generates a sound from the loudspeaker and the corresponding text.



4. Screen setup

- Configure the monitor screen according to the monitor configuration so that all necessary parameter information is displayed, for example as follows:

**Menu - Monitor Setup- Waveform Fields - Field 1 - ECG1**

**- Field 2 - P1**

**- Field 3 - P2**

**- Field 4 - Resp**

**- Digit Fields - Lower Field 1 - NIBP**

**- Lower Field 2 - CO2**

**- Lower Field 3 - Pleth**

**- Lower Field 4 - Temp**

- Connect the patient simulator to the monitor and check that all needed parameter information is showed on the screen.

NOTE: The RESP waveform or Digit Field has to be selected on the screen before the respiration measurement can be turned on.

5. Preset ECG, Respiration, InvBP and SpO<sub>2</sub> measurement settings:

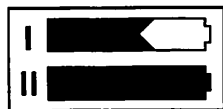
- ECG & Resp** - *ECG Setup - Hr Source - Auto*  
- *Pacemaker - Show*
- *Resp Setup - Size - 1.0*  
- *Resp Rate Source - Auto*  
- *Measurement - On*  
- *Detection Limit - Auto*
- NIBP & Inv. Press** - *P1 Setup&Alarm - Label - Art*  
*P2 Setup&Alarm - Label - Cvp*
- SpO2 & Temp** - *Pleth Scale - Auto*

6. Press the **Menu** button and check the loudspeaker by adjusting the alarm volume in the **Alarms Setup** menu:
- Test the whole volume scale from 1 to 10 by turning the ComWheel and check that the alarm volume changes correspondingly. The alarm sound should be clear and audible at all settings.
7. Select **Service View - Keyboard - Dummy Press**. Press the function keys one by one. Check that each key generates a sound from the loudspeaker and the corresponding text.



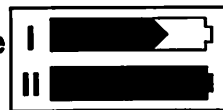
8. Check that the time and date are correct, adjust if necessary:  
**Menu - Monitor Setup - Set Time and Date**
- NOTE: You cannot change the monitor's time settings after a case has started. This prevents losing the trend data.
  - NOTE: If the clock shows time 0:00 continuously after start-ups, the SRAM/Timekeeper's battery on the CPU board, needs to be replaced.
9. Check the battery (If F-LBAT or N-LBB option included):  
Disconnect the power cord (without switching the monitor to standby).

Check that the monitor continues to run normally with battery. The battery indicator should appear onto the upper right hand corner of the screen:



Reconnect the power cord and check that during charging, the charging symbol is displayed and the Battery charge status LED starts flashing:

### 6.2.2 Recorder test

10.  partment cover. Check that the message "Recorder: Cover open" appears on the screen, then close the cover.
11. Select **Main Menu - Record/Print- Record Wave** and check that the recorder starts recording. Select **Stop Wave** to stop recording.

Check that the quality of the recordings is acceptable.




### 6.2.3 PCMCIA card test

12. Insert the Memory card labeled "Data" in the DataCard slot. Check that the message "Data Card inserted" appears onto the message field and the white data card symbol on the upper right hand corner of the screen appears within one minute.



### 6.2.4 Network test

13. Connect the Mon-Net cable and the Identification plug to the monitor.
14. Check that the monitor connects to the Datex-Ohmeda Network, i.e. the network symbol  is displayed on the upper right-hand corner of the screen.

A message regarding the connection to Datex-Ohmeda Information Center should appear in the message field on the screen.

15. Press the **Menu** button to enter the **Network** service menu:

**Monitor Setup - Install/Service** (Password 16-4-34) -  
**Service View** (Password 26-23-8) - **Monitor - Communication**

Check that:

- the "location ID number" matches with the ID plug connected to X3
- the packets and bytes IN is increasing slowly
- the packets and bytes OUT is increasing quickly.
- the "connections" shows the names of the connected networks
- the counters for data errors ("CRC", "Frame", "Transm.") are stable

NOTE: The counters may show values greater than 0. However, any values increasing continuously indicates a problem.

16. Check that the counters for hardware errors ("Intern.", "Missed", "FIFO", "Overrun") all show 0. If any of the counters show a value greater than 0, it indicates a problem on the CPU board.

Return to the **Monitor Setup** menu by selecting **Previous Menu** repeatedly.



### 6.2.5 ECG measurement

17. Enter the service menu:

**Menu - Monitor Setup - Install/Service** (Password 16-4-34) -



**Service View** (Password 26-23-8)

Take down the information regarding monitor software and unit id by selecting **Scroll Vers** and turning the ComWheel or choose **Record Vers** if the recorder is installed.



18. Enter the ESTP:ECG service menu:

**Menu - Monitor Setup - Install/Service** (Password 16-4-34) -  
**Service View** (Password 26-23-8) - **Modules - ESTP : ECG**

Check that the "Timeouts", "Bad checksums" and "Bad c-s by mod" values are not increasing faster than by 50 per second. Check also that the ECG/RESP board memories have passed the internal memory test, i.e. the "RAM", "ROM" and "EEPROM" state all OK.

19. Check that the power frequency value has been set according to the current mains power frequency. Change the setting by selecting **Power Freq**, if necessary.
20. Connect a 5-lead ECG cable to the module. Check that the "Cable type" shows 5 lead. If it shows 3 lead, make sure the used 5-lead ECG cable contains the necessary wiring for cable recognition (pins 0, 8 and 9 connected together).
21. Check that all the electrodes show OFF in the service menu and the message "Leads Off" is shown on the screen.

Connect all the leads together, for example to a suitable screwdriver. Check that all the electrodes show ON and the message "Asystole" appears.

Disconnect one of the leads and check that the corresponding electrode in the service menu shows OFF within 10 seconds from the disconnection, then reconnect the lead. Check the rest of the leads using the same method.

NOTE: When the ground lead (black) is disconnected all the electrodes should show OFF.

NOTE: The asystole and different leads off -messages are shown using certain priority, so even one of the leads is disconnected, the lead related leads off -message may not appear onto the screen.



22. Connect a 3-lead cable to the monitor.

Connect the leads together (e.g. to a screwdriver).

Select one lead (I, II or III) for display.

Detach a lead from the screw driver, and see that the monitor responds as described in the table below. Connect the lead again and check that "Leads off" message disappears.

Lead selection	Lead to be detached	Message
Lead I	L/LA R/RA	Leads off Leads off

	N/LL	Leads off
Lead II	L/LA R/RA N/LL	Leads off Leads off Leads off
Lead III	L/LA R/RA N/LL	Leads off Leads off Leads off

Check that in any case the correspondence electrode (RA, LA or LL) shows off. Electrodes V and RL shows off all the time. In cases I and N, II and R, III and L all electrodes shows off.

23. Connect the leads to a patient simulator.  
The settings and checks with Dynatech Nevada MedSim 300 Patient Simulator:

ECG - BASE - BPM - 160  
PACE - WAVE - NSR

Check that normal ECG waveform is shown, the HR -value is 160 ( $\pm 5$ ) and the "Pacer count" -value is not increasing in the service menu

ECG - PACE - WAVE - ASNC

Check that pacemaker spikes are shown on the ECG waveform, the HR -value changes to 75 ( $\pm 5$ ) and the "Pacer count" -value is increasing according to shown pacemaker spikes.

Set the pacemaker option off:

ECG - PACE - WAVE - NSR



### 6.2.6 Respiration measurement

24. Check that the "Resp Available" and "RESP Measurement" show both ON in the ESTP:ECG service menu.

Do the following settings:

**Menu - ECG & Resp - ECG Lead - II**

and use 3-lead ECG cable.

25. Check the respiration measurement with a patient simulator.

The settings and checks with Dynatech Nevada MedSim 300 Patient Simulator:

BASELINE IMPEDANCE -switch - 500

LEAD SELECT-switch - II/RL-LL

RESP - WAVE - NORM

RATE - 20

OHMS - 1.0

RATIO - 1/1

APNEA - OFF

SHIFT - OFF

Check that the Resp waveform is shown and the RR -value is 20 ( $\pm 5$ ). Change the position of the BASELINE IMPEDANCE -switch and check that appropriate RESP waveform and RR -value are shown again within 30 seconds.

RESP - APNEA - 32 S

Check that the monitor gives the APNEA -alarm.

NOTE: Make sure that only the ECG leads are connected to the simulator during the apnea -test. If other cables are connected at the same time, the respiration signal from the simulator may be disturbed, and therefore, the APNEA -alarm may not be activated.

NOTE: When you have ECG service menu open, spikes will appear on the respiration waveform. These spikes represent the threshold level for detecting inspiration and expiration.



## 6.2.7 Temperature measurement

26. Enter the ESTP : STP service menu:

### **Modules - ESTP : STP**

Check that the "Timeouts", "Bad checksums" and "Bad c-s by mod" values are not increasing faster than by 50 per second. Check also that the STP board memories have passed the internal memory test, i.e. the "RAM", "ROM" and "EEPROM" show all OK.

27. Check that the "Cable" and "Probe" show OFF for channel T1 when no probe is connected.

Connect a temperature test plug into the connector T1. Check that the "Cable" and "Probe" for T1 show ON and the corresponding temperature value appears onto the monitor screen.

28. Check the temperature calibrations using temperature test plugs.  
If the deviation on a temperature reading on the screen is more than 0.1 °C, calibrate the temperature channels according to the instructions in the Technical Reference Manual.
29. Activate the temperature test by selecting **Temp Test** from the menu and pressing the ComWheel twice. When the message "Performing temp test" disappears from the digit field, check that no error messages appear and "Temp error" shows OFF for both channels in the service menu.
30. Check that the module configuration has been set correctly. The configuration in use is shown beside the text "Configuration" in the service menu and it can be either STP, ST or TP. Change the configuration in the **Calibrations** menu, if necessary.

## 6.2.8 Invasive blood pressure measurement

31. Check that the "Cable" and "Probe" for P1 show OFF. Plug a cable with an invasive blood pressure transducer into the front panel connector P1 and check that the "Cable" and "Probe" show ON and the corresponding pressure waveform appears onto the screen.

Perform the same check also for the InvBP channel P2.

32. Calibrate the InvBP channels P1 and P2 according to the instructions in the Technical Reference Manual.

33. Check the InvBP channels with a patient simulator.

The settings and checks with Dynatech Nevada MedSim 300 Patient Simulator:

SENSITIVITY -switch - 5  $\mu\text{V}/\text{V}/\text{mmHg}$

ECG - BASE - BPM - 60 - BP - 1 - WAVE - ATM  
2 - WAVE - ATM

Restore the normal monitoring screen by pressing the key **Normal Screen**.

Connect cables from the channels BP1 and BP2 to the patient connectors P1 and P2. Zero the InvBP channels by pressing the key ZERO ALL button on the monitor front panel.

BP - 1 - WAVE - ART  
2 - WAVE - CVP

Check that appropriate InvBP waveforms are shown and the InvBP values are approximately 120/80 ( $\pm 3$  mmHg) for the channel P1 and 15/10 ( $\pm 2$  mmHg) for the channel P2.

Check that HR- value is calculated from P1 when ECG is not measured (ECG cable disconnected).



### 6.2.9 SpO<sub>2</sub> measurement

34. Check that the message "No probe" is shown when no SpO<sub>2</sub> sensor is connected to the module. Connect a SpO<sub>2</sub> finger probe to the module. Check that the message "Probe off" is shown when the probe is not connected to a finger.
35. Connect the SpO<sub>2</sub> probe onto your finger. Check that the reading of 95-99 and SpO<sub>2</sub> waveform appear. Check that HR- value is calculated from SpO<sub>2</sub> when ECG and InvBP (P1) are not measured.



## 6.2.10 Non Invasive Blood Pressure measurement

36. Enter the NIBP module service menu:

**Monitor Setup - Install/Service** (Password 16-4-34) -  
**Service** (Password 26-23-8) - **Modules - NIBP**

Check that the "Timeouts", "Bad checksums" and "Bad c-s by mod" values are not increasing faster than by 50 per second. Check also that the NIBP board memories have passed the internal memory test, i.e. the "RAM", "ROM" and "EEPROM" show all OK.

37. Check the pump and valves.

Highlight **Pneumatics** from the NIBP menu. Connect a pressure manometer to the NIBP module cuff connector.

Select **Start Pump** and press the ComWheel. Check that the pump turns on and the pressure inside the tubing system starts to increase. Stop the pump by pressing the ComWheel again when the pressure reaches 280 mmHg.

Highlight **Open Exh1**. Press the ComWheel and check that the pressure inside the tubing system starts to drop then press the ComWheel again. Check the other exhaust valve by the same way by selecting **Open Exh2** from the menu.

If necessary, turn the pump on again for a moment to increase the pressure inside the tubing system.

Highlight **SET VALVE**. Press the ComWheel and set the value under the text "Pulse Valve" to number 120 by turning the ComWheel. Press the ComWheel again and check that the pressure inside the tubing system starts to drop. Finish the test by selecting **Previous Menu**.

38. Check the NIBP tubing system for leakages.

Select **Calibrations** from the NIBP service menu.

Connect the pressure manometer to the NIBP module cuff connector. Start the active leak test from the menu by pressing the ComWheel. The module pumps a pressure of about 265 mmHg and then the pump stops.

Wait for 15 seconds for the pressure to stabilize then check that the pressure does not drop more than 6 mmHg per one minute. Release the pressure by pressing the ComWheel once more.

39. Calibration check.

Recalibrate the NIBP measurement. Remember to set the calibration protection back on after calibration.

Disconnect the pressure manometer. Select **Calibrations** and then highlight **Calibration Check**. Press the ComWheel and take down the zero offset values for both pressure transducers, B1 and B2. The values should be within  $\pm 10$  mmHg.

Connect the pressure manometer to the cuff connector and check the calibration with pressures 100 mmHg, 200 mmHg and 260 mmHg. The zero offset value must be added to

---

the displayed pressure value in order to determine the real pressure.

40. Check the watchdog timer activation pressure.

Select **Pneumatics** from the NIBP service menu.

Keep the pressure manometer connected to the cuff connector. Pump up the pressure very slowly and note the value on the manometer when you hear a signal from the loudspeaker. The pressure at where the watchdog timer should activate with an audible signal is

13 mmHg (11...15 mmHg).

Adjust the limit with the trimmer on the NIBP board, if necessary.

41. Check the watchdog timer.

Select **Watchdog** from the NIBP service menu.

Check the watchdog timer in the adult mode. Activate the timer by highlighting **Test Adult** and then pressing the ComWheel. Check that the time beside the text "Watchdog Interval" starts to run. Wait until you hear a signal from the loudspeaker and then check the time again. The time from the adult test should fall within 120-140 seconds.

Check the watchdog timer also in the infant mode by first selecting **Test Infant** from the menu. The time from the infant test should fall within 60-70 seconds.

42. Check the safety valve.

Select **Safety Valve** from the NIBP service menu.

Keep the pressure manometer connected to the cuff connector.

NOTE: Make sure your pressure manometer can be used to measure pressures over 300 mmHg. If such a pressure manometer is not available, perform the check with an adult cuff that is connected around some round object, for example a calibration gas bottle.

Highlight **Start Test**. Start the adult safety valve test by pressing the ComWheel. Wait until the pump stops and the pressure is deflated. Check the pressure values "Max press" and "2 s after stop" for both transducers. All the values should be within 290 - 330 mmHg.

Highlight **Adult**. Press the ComWheel and check that the text changes now to INFANT. Select **Start Test** and wait until the pump stops and the pressure values on the screen have been updated. Check that the values "Max press" and "2 s after stop" are all now within 154...165 mmHg.

Return to the normal monitoring mode by pressing **Normal Screen**.

43. Connect an adult NIBP cuff to the cuff connector and disconnect one of its hoses. Start NIBP measurement by pressing the key **NIBP**, highlight **Start Manual** and press the ComWheel and check that the message "Cuff loose" appears on the screen within 30 seconds. Reconnect the hose and then bend it with your fingers. Restart the measurement and check

that the message “Cuff occlusion” appears on the screen within 30 seconds.

Check that automatic inflation limits are in use:

**Menu – NIBP & Inv.Press - NIBP Setup&Alarm - Inflation Limits – Auto Previous Menu**

44. Connect the cuff onto your arm, highlight START VEN.STASIS in the **NIBP & Inv.Press** menu and press the ComWheel. Check the module identifies the cuff, i.e. the text “Adult” appears into the NIBP digit field for a short moment.

Keep the pressure inside the cuff for about half a minute in order to see that the cuff is not leaking, then press the ComWheel again. Select **Normal Screen**.

45. Keep the cuff on your arm and perform one NIBP measurement. Check that the monitor gives a reasonable measuring result.
46. Connect an infant cuff to cuff connector and wrap it around your fingers. Start NIBP measurement and check that the module identifies the cuff, i.e. the text “Infant” appears into the NIBP digit field. Cancel the measurement after the cuff identification.



### 6.2.11 Mainstream CO<sub>2</sub> measurement

47. Enter the CO<sub>2</sub> service menu and check that the “Timeouts”, “Bad checksums” and “send queue full” values are not increasing faster than by 50 per second.
48. Check that the message “No CO<sub>2</sub> sensor” is displayed when there is no CO<sub>2</sub> sensor connected. Connect a CO<sub>2</sub> sensor to the monitor and check that the message “warming” is displayed.
49. Wait until the “warming” message disappears and the CO<sub>2</sub> value appears to the screen. Breathe at least 5 times to the CO<sub>2</sub> sensor adapter and make sure that the measured values are reasonable and the Respiratory value is calculated.
50. Perform the CO<sub>2</sub> calibration check if necessary.





### 6.2.12 For Light Monitor

51. Perform electrical safety check and leakage current test.



52. Check that the monitor functions normally after the performed electrical safety check.



53. Clean the monitor with suitable detergent.



- Fill in all necessary documents.



## 7 ADJUSTMENTS AND CALIBRATIONS

### 7.1 Pressure safety level detection "OFFSET"

Check from the service view (**Modules - NIBP**) that  $AD0 = 0 \pm 1$ . If it is not: remove the back panel and adjust the trimmer located NIBP boards upper edge AD0 to zero. Pump up the pressure very slowly and check that the value of AD5 changes from negative value to positive value under pressure 11..15 mmHg.

### 7.2 NIBP calibrations

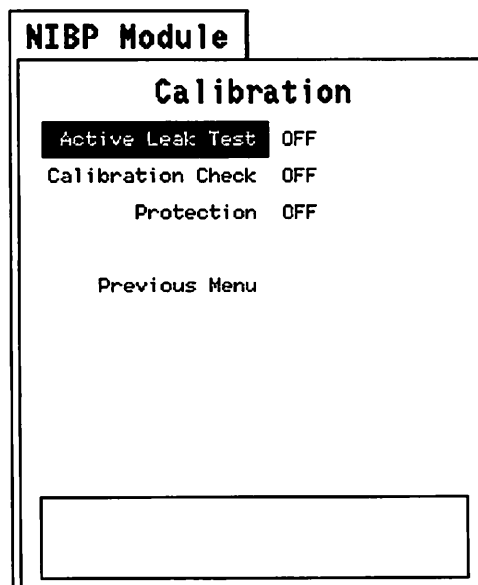
The electronics of NIBP pressure measurement is calibrated at the factory. Zeroing pressure is automatically maintained by the processor. If the zero point of the pressure transducer drifts more than specified, an error message is given and the NIBP board should be recalibrated or replaced.

The calibration can be checked and recalibrated in the NIBP service menu.

The calibration of the primary pressure channel can also be checked from the NIBP setup menu (NIBP, NIBP Setup, Calibration Check). In this case the auto zeroing is performed at start - remove hose before entering to ensure atmospheric pressure to the pressure transducers - the primary pressure is displayed. The zero-offset value should then be zero.

#### 7.2.1 Calibration check

1. Enter **Calibration** menu.



2. Select **Calibration Check** and press the ComWheel.
3. Connect an external precision manometer to the monitor.

- Pump the following pressures to manometer and check the difference between the manometer and monitor pressure display:

**Table 2 NIBP calibration check pressures**

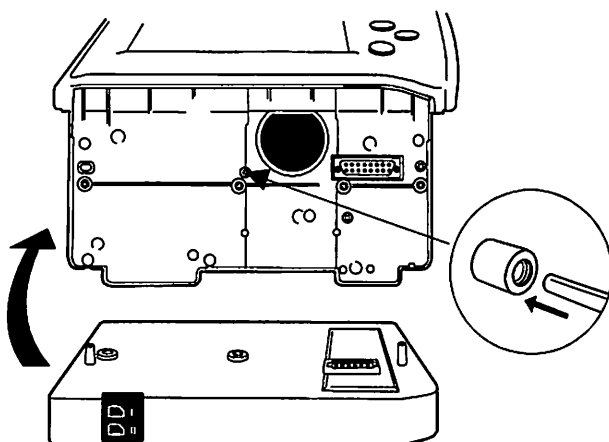
Pressure	Max. error	Example
0 mmHg	$\pm 9$ mmHg (=zero offset)	-2
100 mmHg	100 + zero offset $\pm 2$ mmHg	98 $\pm 2$
200 mmHg	200 + zero offset $\pm 3$ mmHg	198 $\pm 2$

If the error of pressure channel B1 is larger than specified above, the module should be recalibrated. The error of B2 is allowed to be even twice as large because it has no effect on blood pressure measurement accuracy. However, it is recommended to recalibrate the module also when the error of B2 is larger than specified above to ensure best possible operation.

### 7.2.2 Calibration

- Enter **Calibration** menu.
- Remove hoses from front panel connector to enable proper zeroing.
- Select **Calibration**. If it is not available, perform the steps A, B, and C.

NOTE: If there is the battery module in the monitor do remove it before calibration.



- Push the switch at the bottom (marked with the **N** letter) of the device to enable the calibration. This enables menu selection "Protection". The message "Calibration switch ON!" appears.
  - Select **Protection OFF** in the Calibration menu and push the ComWheel while pressing the calibration switch.
  - Release the switch. Menuselection "Calibration" is now enabled, and "Protection" is disabled. When the calibration is enabled, a message "Calibration not protected" appears.
- Start Calibration by pressing the ComWheel. Messages "ZEROING" and "ZEROED" will appear in the NIBP message field. After this a pressure bar will appear.

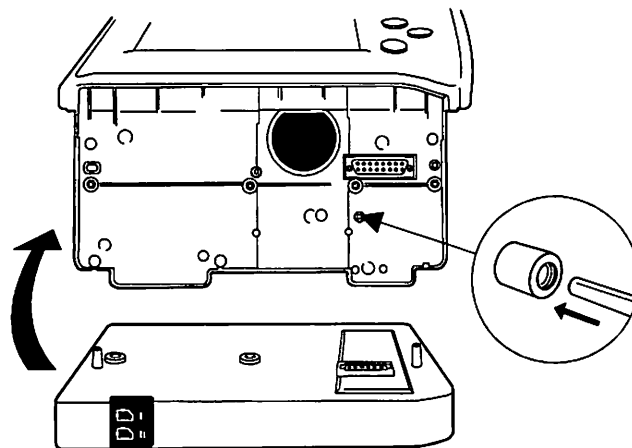
- Connect an external mercury manometer with pump to device through the both tubes of the hose - both transducers B1 and B2 must be calibrated simultaneously. Pump up to a pressure about 200 mmHg according to the manometer. Calibration is possible in the range 150 to 300 mmHg.
- Verify that both pressure values in the prompt field match the manometer reading. If not, adjust by turning the ComWheel. When the values of the pressure bar and the manometer are equal, press the ComWheel to confirm the calibration. The message "Calibrating" will appear onto the NIBP digit field. After a few seconds it is followed by "Calibrated", which means that the calibration has succeeded, and the new calibration data has been saved into EEPROM.
  - To set the protection on:  
Push the calibration switch to the bottom and keep it at the bottom. Select "Protection" ON, push the ComWheel and release the switch.
- Switch off the monitor and then turn it on. Then perform Calibration Check (see the preceding page) to verify the new calibration.

### 7.3 Temperature calibration

NOTE: For the temperature calibration, separate, accurate test plugs (25 °C and 45 °C) are needed. A test set of two plugs is available from Datex-Ohmeda, order code 884515.

Calibrate temperature when measured test values deviate more than  $\pm 0.1$  °C, and always after LM-STP board replacement.

1. Enter ESTP: STP service menu.  
**(Monitor Setup - Install/Service (password 16-4-34), Service (password 26-23-8), Modules).**
2. Enter **Calibrations** menu.
3. Press the protect button at the bottom of the monitor and choose OFF in protect mode. Release the button.



4. Select **Calibrate T1** in the service view.
5. Insert calibration plug (25 °C) into Temp connector.
6. Press the ComWheel two times.
7. Insert calibration plug (45 °C) into Temp connector.

8. Press the ComWheel two times.
9. Press in the protect button at the bottom of the module and choose ON in protect mode. Release the button.

## 7.4 Invasive pressure calibration

Calibrate invasive pressure when the pressure transducer (probe) is replaced with a different type of transducer, and when LM-STP board is replaced.

1. Enter ESTP: STP service menu.  
**(Monitor Setup - Install/Service (password 16-4-34) - Service (password 26-23-8) - Modules).**
2. Enter **Calibrations** menu.
3. Connect a pressure transducer with a pressure manometer to the P1/P2 connector. Choose Calibrate P1 or Calibrate P2. Leave the transducer to room air pressure.
4. Press the ComWheel to start zeroing.
5. Supply a pressure of 100 mmHg to 300 mmHg to the transducer. The recommended pressure is 200 mmHg.
6. Set the pressure on the display to match the pressure reading on the manometer and press the ComWheel. A tolerance of  $\pm 1$  mmHg is allowed.

The text "Calibrated" will appear on the display.

## 8 GENERAL TROUBLESHOOTING

### 8.1 Troubleshooting flowchart

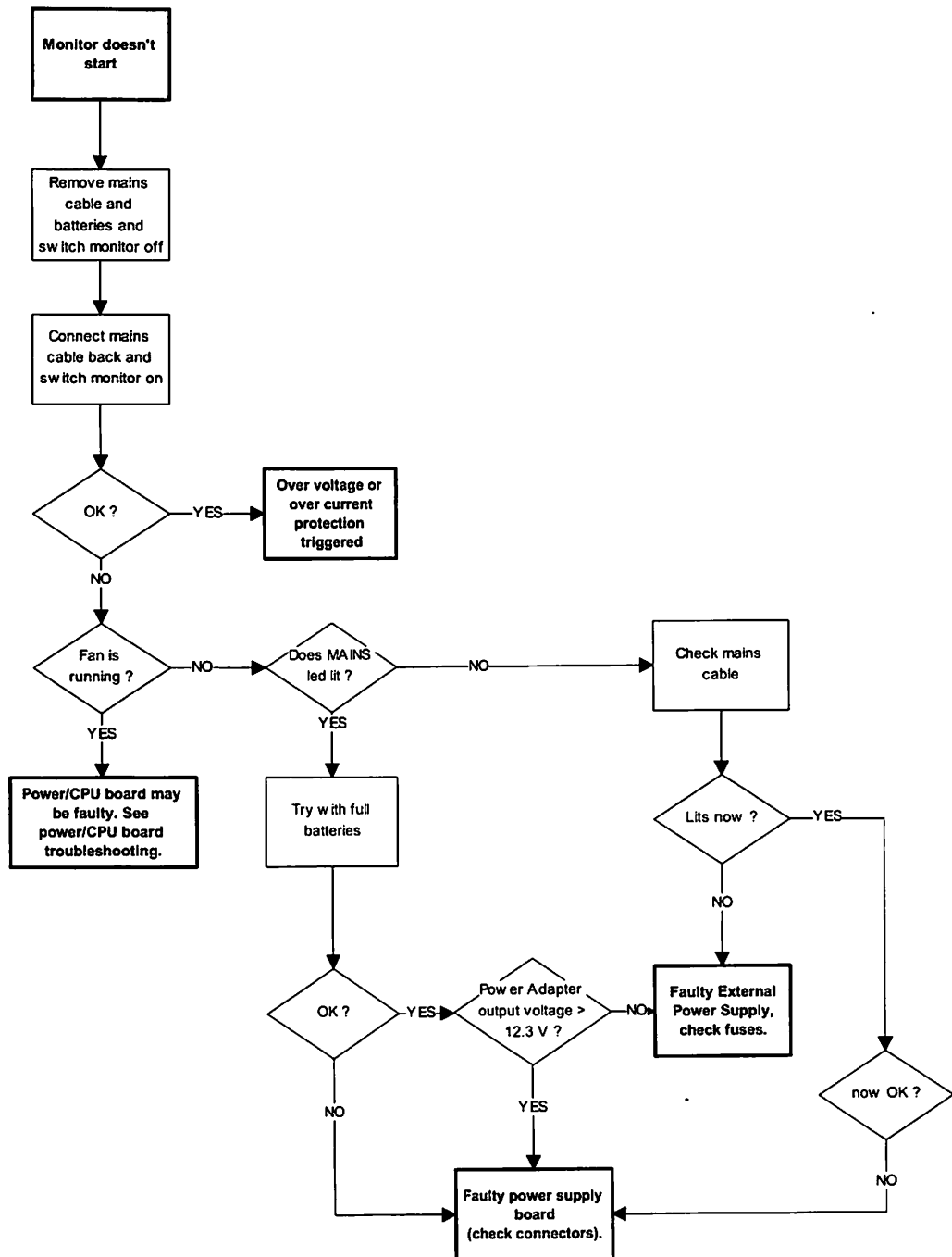


Figure 3 General troubleshooting chart









## 9 SERVICE MENU

### 9.1 SW version / unit ID

Software version and Unit ID are shown in the Service View menu.

1. Press **Menu** key.
2. Enter **Monitor Setup - Install/Service** (password 16-4-34) - **Service View** (password 26-23-8).

Service View	SW version / Unit id
Monitor 	Monitor Frame ----- MAIN sw pr. 891263-3.0 1997-12-08
Keyboard 	? ?
Modules 	Power Board ----- ? ?
Service Log 	ECG ----- ? ?
Scroll Vers	STP ----- ? ?
Previous Menu	NIBP ----- ? ?

Software strings have the following format:

XXXX SW PPPPP-N.N YYYY-MM-DD

where:

XXXX = [MAIN] / [ESTP] / [NIBP] / [BOOT] / [PWR]

PPPPPP = Program code

N.N = Program version

YYYY = Year

MM = Month

DD = Day

Hardware strings have the following format:

XXXXXXXX YYYY-MM-DD NNNNNNNN LLL

where:

XXXXXXXX = Control number of the board

YYYY = Year

MM = Month

DD = Day

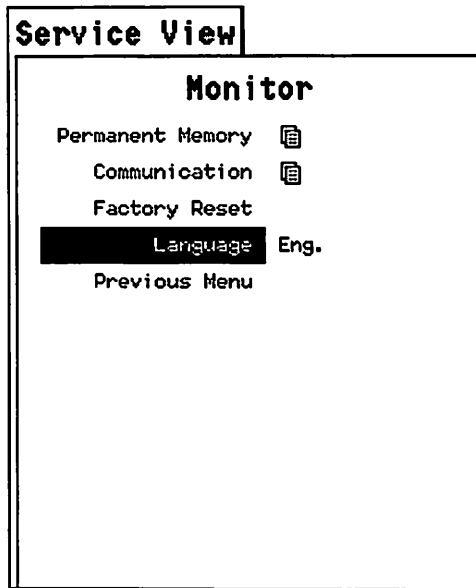
NNNNNNNN = Code of the board

LLL = Level

## 9.2 Language selection

Language can be selected in the Monitor menu.

1. Press **Menu** key.
2. Enter **Monitor Setup - Install/Service** (password 16-4-34) - **Service View** (password 26-23-8) - **Monitor**.



## 9.3 Monitor configuration

Monitor configuration can be selected in the Monitor menu.

1. Press **Menu** key.
2. Enter **Monitor Setup - Install/Service** (password 16-4-34) - **Service View** (password 26-23-8) - **Monitor**.

NOTE: MS+SS- CO<sub>2</sub> should always be set to "NO"

## 10 GENERAL SPECIFICATIONS

### Safety standards

Designed to meet IEC 60601-1 and CAN/CSA C22.2 No 601.1

### 10.1 Parameter specifications

#### 10.1.1 ECG

Measured leads:	I, II or III
Frequency response:	0.5...30 Hz (-3 dB, with 50 Hz reject filter) 0.5...40 Hz (-3 dB, with 60 Hz reject filter)
Sweep speed:	12.5, 25, or 50 mm/s
<b>Heart rate/Pulse rate</b>	
Measurement range:	30...250 bpm
Measurement accuracy:	$\pm 5\%$ or $\pm 5$ bpm whichever is greater
Display resolution:	1 bpm
Averaging time:	10 s
Display update time:	5 s
Alarms:	asystole, leads-off detection, adjustable high and low alarm limits for heart rate
Gain range:	0.2...5.0 cm/mV
Allowable DC differential offset:	$\pm 300$ mV
Pacemaker pulse detection:	detection level: 5...500 mV, pulse duration: 0.5...2 ms

#### 10.1.2 Impedance respiration

Measuring range:	impedance, 0.2...6 ohm
Max. base impedance:	5 kOhm
Respiration range:	4...120 resp/min
Accuracy:	$\pm 5\%$ or $\pm 5$ resp/min whichever is greater
Averaging:	30 s
Update interval:	10 s
Display resolution:	1 resp/min
Sweep speed (trace):	slow 0.62 mm/s, fast 6.25 mm/s
Alarms:	apnea, adjustable high and low alarm limits for respiration rate
Gain range:	0.1...5 cm/ohm

### 10.1.3 Pulse oximetry (SpO<sub>2</sub>)/Pleth

Measurement method:	red and infrared light absorption SpO <sub>2</sub>
Measurement range:	40...100%
Calibration range:	50...100 %; calibrated against functional oxygen saturation
- with N-LNSAT:	70...100 %; calibrated against functional oxygen saturation
Display resolution:	1 digit (1 % of SpO <sub>2</sub> )
Measurement accuracy <sup>*)</sup> :	100...80 %, ± 2 digits (± 1SD) 80...50 %, ± 3 digits (± 1SD) 50...40%, unspecified
- with N-LNSAT <sup>**)</sup> :	100... 70 %, ± 2 digits (± 1SD) for sensor types D-25/D-25L, N-25, D-20, I-20 100... 70 %, ± 2,5 digits (± 1SD) for sensor OXICLIQ A, OXICLIQ P 100... 70 %, ± 3 digits (± 1SD) for sensor types D-YS, DS-100A, OXI-A/N, OXI-P/I 100... 70 %, ± 3,5 digits (± 1SD) for sensor type R-15 70...40%, unspecified
Display averaging time:	adjustable 20 s, 10 s, or beat-to-beat
- with N-LNSAT:	adjustable slow, normal or fast
Alarms:	probe off, no probe, no pulse, adjustable high and low, alarm limits for SpO <sub>2</sub>

#### Pulse rate

Measurement range:	30...250 bpm
Display resolution:	1 digit (1 bpm)
Measurement accuracy:	± 5 % or ± 5 bpm
- with N-LNSAT:	± 3 bpm
Alarms:	adjustable high and low alarm limits for pulse rate

#### Plethysmographic pulse waveform

Scales:	proportional scaling: 2, 5, 10, 20, 50 mod % or automatic scaling
- with N-LNSAT:	automatically scaled by the measurement board, the actual scale unknown.

<sup>\*)</sup> Accuracy is based on deep hypoxia studies using Datex-Ohmeda Finger Sensors on volunteered subjects. Arterial blood samples have been analyzed by a Radiometer OSM Co-oximeter. Refer to Datex-Ohmeda Sat Sensor directions for specific SpO<sub>2</sub> accuracy.

<sup>\*\*)</sup>Option N-LNSAT: Accuracy specifications are based on testing the monitor and sensor on healthy adult volunteers in induced hypoxia studies.

### 10.1.4 Temperature

Measurement units:	°C or °F
Measurement range:	10...45 °C (50...113 °F)

Measurement resolution:	0.1°C (0.1°F)
Measurement accuracy:	±0.1 °C (25...45.0 °C) ±0.2 °C (10...24.9 °C)
Probe type:	Compatible with YSI 400 series

### 10.1.5 Non-invasive blood pressure

Measurement principle:	Oscillometric with linear deflation		
Deflation speed:	Heart rate dependent, 5...13 mmHg/s		
Measurement range:	Adult 25...260 mmHg child 25...190 mmHg infant 15...140 mmHg		
Pulse rate range:	30...250 bpm		
Measurement intervals:	manual and selectable intervals 1, 2.5, 3, 5, 10, 15, 30, 60 min or continuous STAT mode		
Numeric display:	systolic, diastolic and mean arterial pressure		
Alarms:	cuff loose, cuff occlusion, adjustable high and low alarm limits for systolic, diastolic, mean or off		
Typical measurement time:	adult 23 s and infant 20 s		
Safety features:	adult	child	infant
Initial inflation pressure (mmHg):	185	150	120
Max. inflation pressure (mmHg):	280	200	150
Overpressure limit (max. 2 s; mmHg):	320	220	165
Max. inflation time (>15 mmHg, min):	2	2	1
Safety valve (mmHg):	320	220	165

### 10.1.6 Invasive blood pressure (LMP1 models only)

Measurement range:	-40...320 mmHg
Measurement accuracy:	± 5 % or ± 2 mmHg
Numeric display	
Range:	40...320 mmHg
Resolution:	1 mmHg
Averaging:	over 5 s or end-expiratory filtering
Display update:	every 5 s
Alarms:	adjustable high and low alarm limits for systolic, diastolic and mean pressures, or off
<b>Waveform display</b>	
Range:	-30...300 mmHg
Scales:	adjustable in 10 mmHg increments

**Pulse rate**

Measurement range:	30...250 bpm
Resolution:	1 bpm
Accuracy:	± 5 % or 5 bpm
Transducer sensitivity:	5 $\mu$ V/V/mmHg, 5 Vdc, max.20 mA
Pressure filter:	22 Hz (-3 dB) for P1, Art 9 Hz (-3dB) for P2, CVP, PA, ICP

**10.1.7 CO<sub>2</sub> (option N-LCM)**

Principle of operation:	Mainstream, non-dispersive infrared, single beam, single frequency, fully chopped, ratiometric
Measurement range:	0-99 mmHg / 0-13 vol-% / 0-13 kPa
Accuracy**)	0-40 mmHg / 0-5.3 vol-%: ± 2 mmHg / ±0.3 vol-% 41-76 mmHg / 5.3-10%: ± 5% of reading 77-99 mmHg / 10-13%: ± 10% of reading
Respiration rate measurement range:	4-150 breaths/minute
Pressure compensation:	automatic, continuous
Gas compensations:	User selectable O <sub>2</sub> , N <sub>2</sub> O or OFF
Calibration:	No routine calibration required; automatic self-calibration every 30 ms
Alarms:	adjustable high and low alarm limits for Et/Fi CO <sub>2</sub> and respiration rate
CO <sub>2</sub> sensor weight:	< 18,5 g (excluding cable)
Cable length:	3 meters
Warm-up time:	< 80 seconds from 25°C
Response time:	100 ms

\*\*\*) typical value in conditions 22,5°C, 760 mmHg, CO<sub>2</sub> in balance air.

**10.2 General**

Monitor (WxDxH):	325 x 160 x 210 mm / 12.8 x 6.3 x 8.3"
Battery module (WxDxH):	290 x 150 x 40 mm / 11.4 x 5.9 x 1.6"
Weight w/o batteries:	4.2 kg/9.3 lb.
Weight w/ batteries:	6.1 kg/13.5 lb.
Input voltage:	12.5 V DC
Power consumption	17.5 ... 37 W depending on the options used
Safety standards:	Designed to meet IEC 601-1, CAN/CSA C22.2 No. 601.1 and UL 2601-1, CE-marking according to Directive 93/42/EEC
Output specifications:	RS-232 computer serial output Defibrillation synchronization signal: according to ANSI/AAMI EC13-1992. Time interval from R peak to sync pulse output ≤ 35 ms Nurse Call Analog output, 2 fixed and 2 freely configurable outputs
Printing:	Local printing with laser printer (PCL5), or via network.
Recorder option:	Built-in three channel thermal array recorder.

### 10.2.1 Environmental conditions

Operating temperature:	0...40 °C (32...104 °F), +10...40 °C (50...104 °F) mainstream sensor
Battery charging temperature:	+10...40 °C (50...104 °F),
Storage temperature:	-30...70 °C (-22...158 °F), -20...60 °C (-4...140 °F) with CO <sub>2</sub> -30...50 °C (-22...122 °F) for batteries
Relative humidity:	5...95 % non-condensing

For accessories, please refer to the Datex-Ohmeda Patient Monitor supplies and accessories catalogue. Specifications subject to change without notice.

### 10.3 Option codes

Description	Order code
Light Monitor	F-LM1 w/ ECG, Resp, NIBP, SpO <sub>2</sub> , Temp
Light Monitor	F-LMP1 w/ ECG, Resp, NIBP, SpO <sub>2</sub> , Temp, 2xIBP
Light Monitor Power Adapter	N-LPOW Power adapter, 110/220 V
Light Monitor Transport Power Adapter	N-LPOWT Transport power adapter, 12-32 V
Light Monitor Battery Module	F-LMBAT Battery module w/ two batteries
Light External Battery Charger	N-LCHGR Battery charger w/ two batteries
Light Monitor Recorder	N-LREC Built-in 3-channel thermal array recorder
Light Monitor CO <sub>2</sub> Option	N-LCM Mainstream CO <sub>2</sub>
Mainstream CO <sub>2</sub> sensor	902300
DataCard Option	N-LDATA
Network Option	N-LNET
DataCard & Network Option	N-LDNET
Backup battery	N-LBB

### 10.4 Display

Display size and type:	9" monochrome EL display
Number of traces:	Up to 4
Display resolution:	640 x 400
Display layout:	User-configurable

Integrated direct function keys, menu key and ComWheel™ for selections and adjustments in menus.

#### 10.4.1 Slave display

Type	VGA
Display resolution:	640 x 480
Dot clock	25 MHz. Black level 0 V, full intensity 0.7 V



### 10.4.2 Trends

Graphical:	2, 4, 12 and 24 h
Numerical:	all parameters, sampled every 5 min and after NIBP measurement
Trend cursor:	Both in graphical and numerical trends

### 10.4.3 Alarms

- Adjustable high and low alarms for HR, Resp, NIBP, SpO<sub>2</sub>, Temp, CO<sub>2</sub> (Et/Fi) and Invasive Pressures Alarm system classified according to priority; visually with color and audio tone coded
- Central alarm display and adjustment page
- 10 min graphical mini trends referenced to set alarm limits
- Automatic alarm limits function; alarm limits automatically calculated from current parameter reading when selected.
- Alarms history displaying 10 latest alarms

## 10.5 Light Monitor battery module (optional) (w/2 battery slots)

Type:	NiCd battery
Capacity:	Up to 2 hours (1 h/batt) typical on full charge at 23 °C
Recharging:	When connected to AC
Charging time:	3.5 h / battery to full capacity

## 10.6 Light Monitor backup battery (optional)

Type:	NiCd battery
Capacity:	Up to 30 min typical on full charge at 23 °C
Recharging:	When connected to AC or DC (N-LPOWT)
Charging time:	1.5 h / battery to full capacity

## 10.7 External power adapter

AC voltage range:	220-240 V / 100-120 V ~ 50/60 Hz
Allowed AC voltage fluctuations:	100 V -10%...120 V +10%, 220 V -10%...240 V +10%
DC output voltage:	12.5 V and 18.5 V
Protection class:	Class I
Grounding:	Hospital grade

## 10.8 Power adapter for transport vehicles (optional)

Input voltage range and fluctuations:	12 Vdc -15%...32 Vdc +10%
Output voltage:	12.5 Vdc and 18.5 Vdc

## 10.9 Light External Battery Charger (optional)

Mains voltage	100...240 VAC
---------------	---------------

Max. input power	90 VA
Mains frequency	50...60 Hz
Charge current	1.7 A, $\pm 10\%$
Discharge current	0.6 A, $\pm 10\%$
Typical charging time	1 h per battery / 1.8 Ah 1.5 h per battery / 2.8 Ah

## 10.10 Output specifications

**WARNING** Use only cables with shielding against electromagnetic interference.

### 10.10.1 Nurse Call and Defibrillator Synchronization Signals

The nurse call signal is generated when the alarm is activated. Alarm silencing suppresses the nurse call signal.

The defibrillator synchronization signal is generated by ECG. The pulse will be given on each rising R-wave edge on QRS-complex. The pulse amplitude is 5 V and width is 10 ms. When the def sync signal is active, the signal is set to state 1. After 10 ms the state is set to 0. A new pulse will not be generated before the previous pulse is deactivated.

## **APPENDICES**

***APPENDIX A, Functional check form***

***APPENDIX B, Service check form***

***APPENDIX C, EMC Guidance***



# FUNCTIONAL CHECK FORM

## Datex Ohmeda S/5™ Light Monitor

Customer _____
Service _____
Service engineer _____ Date _____

### Monitor configuration

Monitor model: F-LM1 <input type="checkbox"/>	Model with 2 InvBP measurements, F-LMP1 <input type="checkbox"/>
---	--

Parameter measurement options		Data collecting and data management options	
N-LCM	Mainstream CO <sub>2</sub> <input type="checkbox"/>	N-LREC	Recorder <input type="checkbox"/>
N-LNSAT	Nellcor SpO <sub>2</sub> <input type="checkbox"/>	N-LNET	Network <input type="checkbox"/>
		N-LDATA	DataCard <input type="checkbox"/>
		N-LDNET	DataCard + Network <input type="checkbox"/>

OK = Test OK      N.A. = Test not applicable      Fail = Test Failed

General functional inspection	OK	N.A.	Fail
5.1 General functional inspection	<input type="checkbox"/>	<input type="checkbox"/>	<input type="checkbox"/>
5.1.1 Recorder test	<input type="checkbox"/>	<input type="checkbox"/>	<input type="checkbox"/>
5.1.2 PCMCIA card test	<input type="checkbox"/>	<input type="checkbox"/>	<input type="checkbox"/>
5.1.3 Network test	<input type="checkbox"/>	<input type="checkbox"/>	<input type="checkbox"/>
5.1.4 ECG board test	<input type="checkbox"/>	<input type="checkbox"/>	<input type="checkbox"/>
5.1.5 STP board test	<input type="checkbox"/>	<input type="checkbox"/>	<input type="checkbox"/>
5.1.6 NIBP board test	<input type="checkbox"/>	<input type="checkbox"/>	<input type="checkbox"/>
5.1.7 Mainstream CO <sub>2</sub> test	<input type="checkbox"/>	<input type="checkbox"/>	<input type="checkbox"/>
Performance checks	OK	N.A.	Fail

1. Monitor screen configuration	<input type="checkbox"/>	<input type="checkbox"/>	<input type="checkbox"/>
2. SpO <sub>2</sub> check	<input type="checkbox"/>	<input type="checkbox"/>	<input type="checkbox"/>
3. InvBP simulation	<input type="checkbox"/>	<input type="checkbox"/>	<input type="checkbox"/>
4. SpO <sub>2</sub> : No probe and Probe off -messages	<input type="checkbox"/>	<input type="checkbox"/>	<input type="checkbox"/>
5. SpO <sub>2</sub> value (95-99 %) and HR value	<input type="checkbox"/>	<input type="checkbox"/>	<input type="checkbox"/>
6. SpO <sub>2</sub> : No probe -message	<input type="checkbox"/>	<input type="checkbox"/>	<input type="checkbox"/>
7. NIBP measurement	<input type="checkbox"/>	<input type="checkbox"/>	<input type="checkbox"/>
8. CO <sub>2</sub> sensor	<input type="checkbox"/>	<input type="checkbox"/>	<input type="checkbox"/>
9. CO <sub>2</sub> check	<input type="checkbox"/>	<input type="checkbox"/>	<input type="checkbox"/>

<b>Notes</b> _____ _____ _____
--------------------------------------

<b>Signature</b> _____
------------------------

# SERVICE CHECK FORM

## Datex Ohmeda S/5™ Light Monitor

Customer _____
Service _____
Service engineer _____ Date _____

### Monitor configuration

Monitor model: F-LM1 <input type="checkbox"/>	Model with 2 InvBP measurements, F-LMP1 <input type="checkbox"/>
---	--

Parameter measurement options		Data collecting and data management options	
N-LCM	Mainstream CO <sub>2</sub> <input type="checkbox"/>	N-LREC	Recorder <input type="checkbox"/>
N-LNSAT	Nellcor SpO <sub>2</sub> <input type="checkbox"/>	N-LNET	Network <input type="checkbox"/>
		N-LDATA	DataCard <input type="checkbox"/>
		N-LDNET	DataCard + Network <input type="checkbox"/>

OK = Test OK      N.A. = Test not applicable      Fail = Test Failed

	OK	N.A.	Fail
6.2.1 Visual inspection	<input type="checkbox"/>	<input type="checkbox"/>	<input type="checkbox"/>
6.2.2 Recorder test	<input type="checkbox"/>	<input type="checkbox"/>	<input type="checkbox"/>
6.2.3 PCMCIA card test	<input type="checkbox"/>	<input type="checkbox"/>	<input type="checkbox"/>
6.2.4 Network test	<input type="checkbox"/>	<input type="checkbox"/>	<input type="checkbox"/>
6.2.5 ECG measurement	<input type="checkbox"/>	<input type="checkbox"/>	<input type="checkbox"/>
6.2.6 Respiration measurement	<input type="checkbox"/>	<input type="checkbox"/>	<input type="checkbox"/>
6.2.7 Temperature measurement	<input type="checkbox"/>	<input type="checkbox"/>	<input type="checkbox"/>
6.2.8 InvBP measurement	<input type="checkbox"/>	<input type="checkbox"/>	<input type="checkbox"/>
6.2.9 SpO <sub>2</sub> measurement	<input type="checkbox"/>	<input type="checkbox"/>	<input type="checkbox"/>
6.2.10 NIBP measurement	<input type="checkbox"/>	<input type="checkbox"/>	<input type="checkbox"/>

Datex-Ohmeda S/5 Light Monitor

	OK	N.A.	Fail
6.2.11 Mainstream CO <sub>2</sub> measurement	<input type="checkbox"/>	<input type="checkbox"/>	<input type="checkbox"/>
6.2.12 For Light Monitor			
Electrical safety check and leakage current test	<input type="checkbox"/>	<input type="checkbox"/>	<input type="checkbox"/>
Monitor functions after electrical safety check and leakage current test	<input type="checkbox"/>	<input type="checkbox"/>	<input type="checkbox"/>
Cleaning	<input type="checkbox"/>	<input type="checkbox"/>	<input type="checkbox"/>

**Notes** \_\_\_\_\_  
\_\_\_\_\_  
\_\_\_\_\_

**Signature** \_\_\_\_\_



## EMC GUIDANCE

### Guidance and manufacturer's declaration – electromagnetic emissions


Guidance and manufacturer's declaration – electromagnetic emissions		
The S/5 Light Monitor is intended for use in the electromagnetic environment specified below. The customer or the user of the S/5 Light Monitor should assure that it is used in such an environment.		
Emissions test	Compliance	Electromagnetic environment - guidance
RF emissions CISPR 11	Group 1	The S/5 Light Monitor is suitable for use in all establishments other than domestic and those directly connected to the public low-voltage power supply network that supplies buildings used for domestic purposes.
RF emissions CISPR 11	Class A	
Harmonic emissions IEC 61000-3-2	Class A	
Voltage fluctuations/ flicker emissions IEC 61000-3-3	Complies	

**Guidance and manufacturer's declaration – electromagnetic immunity**

<b>Guidance and manufacturer's declaration – electromagnetic immunity</b>			
The S/5 Light Monitor is intended for use in the electromagnetic environment specified below. The customer or the user of the S/5 Light Monitor should assure that it is used in such an environment.			
<b>Immunity test</b>	<b>IEC 60601 test level</b>	<b>Compliance level</b>	<b>Electromagnetic environment - guidance</b>
Electrostatic discharge (ESD) IEC 61000-4-2	±6 kV contact ±8 kV air	±6 kV contact ±8 kV air	Floors should be wood, concrete or ceramic tile. If floors are covered with synthetic material, the relative humidity should be at least 30 %.
Electrical fast transients/bursts IEC 61000-4-4	±2 kV for power supply lines ±1 kV for input/output lines	±2 kV or ±1 kV <sup>1)</sup> for power supply lines ±1 kV for input/output lines	Mains power quality should be that of a typical commercial or hospital environment. In case of disturbance it is recommended to use transient filter on power input lines.
Surge IEC 61000-4-5	±1 kV differential mode ±2 kV common mode	±1 kV differential mode ±2 kV common mode	Mains power quality should be that of a typical commercial or hospital environment.
Voltage dips, short interruptions and voltage variations on power supply lines IEC 61000-4-11	<5 % $U_T$ (>95 % dip in $U_T$ ) for 0.5 cycle  40 % $U_T$ (60 % dip in $U_T$ ) for 5 cycles  70 % $U_T$ (30 % dip in $U_T$ ) for 25 cycles  <5 % $U_T$ (>95 % dip in $U_T$ ) for 5 sec	<5 % $U_T$ (>95 % dip in $U_T$ ) for 0.5 cycle  40 % $U_T$ (60 % dip in $U_T$ ) for 5 cycles  70 % $U_T$ (30 % dip in $U_T$ ) for 25 cycles  <5 % $U_T$ (>95 % dip in $U_T$ ) for 5 sec	Mains power quality should be that of a typical commercial or hospital environment. If user of the S/5 Light Monitor requires continued operation during power mains interruptions, it is recommended that the S/5 Light Monitor be powered from an uninterruptible power supply or a battery.
Power frequency (50/60 Hz) magnetic field IEC 61000-4-8	3 A/m	3 A/m	Power frequency magnetic field should be at levels characteristic of a typical location in a typical commercial or hospital environment.
NOTE $U_T$ is the a.c. mains voltage prior to application of the test level.			

<sup>1)</sup> ±1 kV for mainstream CO<sub>2</sub> measurement

## Guidance and manufacturer's declaration – electromagnetic immunity

Guidance and manufacturer's declaration – electromagnetic immunity			
The S/5 Light Monitor is intended for use in the electromagnetic environment specified below. The customer or the user of the S/5 Light Monitor should assure that it is used in such an environment.			
Immunity test	IEC 60601 test level	Compliance level	Electromagnetic environment - guidance
<p>Conducted RF IEC 61000-4-6</p> <p>Radiated RF IEC 61000-4-3</p>	<p>3 V<sub>rms</sub> 150 kHz to 80 MHz</p> <p>3 V/m 80 MHz to 2.5 GHz</p>	<p>3 V<sub>rms</sub></p> <p>3 V/m</p>	<p>Portable and mobile RF communications equipment should be used no closer to any part of the S/5 Light Monitor, including cables, than the recommended separation distance calculated from the equation applicable to the frequency of the transmitter.</p> <p><b>Recommended separation distance</b></p> $d = 1.2 \sqrt{P}$ <p><math>d = 1.2 \sqrt{P}</math> 80 MHz to 800 MHz</p> <p><math>d = 2.3 \sqrt{P}</math> 800 MHz to 2.5 GHz</p> <p>where <math>P</math> is the maximum output power rating of the transmitter in watts (W) according to the transmitter manufacturer and <math>d</math> is the recommended separation distance in metres (m).</p> <p>Field strengths from fixed RF transmitters, as determined by an electromagnetic site survey,<sup>a</sup> should be less than the compliance level in each frequency range.<sup>b</sup></p> <p>Interference may occur in the vicinity of equipment marked with the following symbol:</p> 
NOTE 1 At 80 MHz and 800 MHz, the higher frequency range applies.			
NOTE 2 These guidelines may not apply in all situations. Electromagnetic propagation is affected by absorption and reflection from structures, objects and people.			
<p><sup>a</sup> Field strengths from fixed transmitters, such as base stations for radio (cellular/cordless) telephones and land mobile radios, amateur radio, AM and FM radio broadcast and TV broadcast cannot be predicated theoretically with accuracy. To assess the electromagnetic environment due to fixed RF transmitters, an electromagnetic site survey should be considered. If the measured field strength in the location in which the S/5 Light Monitor is used exceeds the applicable RF compliance level above, the S/5 Light Monitor should be observed to verify normal operation. If abnormal performance is observed, additional measures may be necessary, such as reorienting or relocating the S/5 Light Monitor.</p> <p><sup>b</sup> Over the frequency range 150 kHz to 80 MHz, field strengths should be less than 3 V/m.</p>			

**Recommended separation distances between portable and mobile RF communications equipment and the S/5 Light Monitor.**

<b>Recommended separation distances between portable and mobile RF communications equipment and the S/5 Light Monitor.</b>			
The S/5 Light Monitor is intended for use in an electromagnetic environment in which radiated RF disturbances are controlled. The customer or the user of the S/5 Light Monitor can help prevent electromagnetic interference by maintaining a minimum distance between portable and mobile RF communications equipment (transmitters) and the S/5 Light Monitor as recommended below, according to the maximum output power of the communications equipment.			
Rated maximum output power of transmitter W	Separation distance according to frequency of transmitter m		
	150 kHz to 80 MHz $d = 1.2\sqrt{P}$	80 MHz to 800 MHz $d = 1.2\sqrt{P}$	800 MHz to 2.5 GHz $d = 2.3\sqrt{P}$
0.01	0.12	0.12	0.23
0.1	0.38	0.38	0.73
1	1.2	1.2	2.3
10	3.8	3.8	7.3
100	12	12	23
For transmitters rated at a maximum output power not listed above, the recommended separation distance $d$ in meters (m) can be estimated using the equation applicable to the frequency of the transmitter, where P is the maximum output power rating of the transmitter in watts (W) according to the transmitter manufacturer.			
NOTE 1	At 80 MHz and 800 MHz, the separation distance for the higher frequency range applies.		
NOTE 2	These guidelines may not apply in all situations. Electromagnetic propagation is affected by absorption and reflection from structures, objects and people.		

# **Datex-Ohmeda S/5™ Light Monitor**

## **Planned Maintenance Instructions**

All specifications are subject to change without notice.

Document No. 8001934-1

September 2003

Datex-Ohmeda, Inc.  
P.O. Box 7550, Madison  
WI 53707-7550, USA  
Tel. +1-608-221-1551  
Fax +1-608-222-9147  
[www.us.datex-ohmeda.com](http://www.us.datex-ohmeda.com)

Datex-Ohmeda Division,  
Instrumentarium Corp.  
P.O. Box 900, FIN-00031  
DATEX-OHMEDA, FINLAND  
Tel. +358 10 39411 Fax +358 9 146 3310  
[www.datex-ohmeda.com](http://www.datex-ohmeda.com)  
© Instrumentarium Corp. All rights reserved.

## Intended purpose

Datex-Ohmeda S/5 Light Monitor is intended for stationary and mobile monitoring of patient's ECG, SpO<sub>2</sub>, non-invasive and invasive blood pressure, temperature, respiration and CO<sub>2</sub> in hospitals and ambulances. When used outdoors, the monitor must be in the protective case.

The monitor is intended for use by qualified medical personnel only.

The S/5 Light Monitor is intended for patients with weight from 5 kg (11 lb.) up.

Respiration monitoring is intended for patients three years old and up.

## Classification according to IEC 60601-1

- CLASS I EQUIPMENT and INTERNALLY POWERED EQUIPMENT according to the type of protection against electrical shock.
- TYPE BF or CF equipment according to the degree of protection against electric shock is indicated with a symbol beside each patient connector.
- Degree of protection against harmful ingress of water as detailed in the IEC 60529:  
Monitor: IPX1, vertically falling water drops shall have no harmful effects (applicable when the monitor is in upright position, or tilted backwards). In the protective case IPX4, splash proof, when the case is closed properly, the monitor is intact and operates on battery power.  
Power adapter: IPX0, ordinary equipment.  
Power adapter for Transport Vehicles: IPX1.
- EQUIPMENT not suitable for use in the presence of a FLAMMABLE ANESTHETIC MIXTURE with air or with oxygen or nitrous oxide.
- CONTINUOUS OPERATION according to the mode of operation.

## Classification according to EU Medical Device Directive

- The monitor is classified as IIb.

## Responsibility of the manufacturer

Instrumentarium Corp. is responsible for the effects on safety, reliability and performance of the equipment only if:

- assembly, operations, extensions, readjustments, modifications, service and repairs are carried out by authorized personnel.
- the electrical installation of the relevant room complies with appropriate requirements.
- the equipment is used in accordance with the User's Reference Manual and serviced and maintained in accordance with the Technical Reference Manual.

The CO<sub>2</sub> measuring option (N-LCM) is manufactured for Instrumentarium Corp. by Pryon Corp., 8500 S.W. Creekside Place, Beaverton, OR 97008-7107 USA.

The Nellcor option (N-LNSAT) is manufactured for Instrumentarium Corp. by Mallinckrodt Inc., 675 McDonnell Boulevard, P.O. Box 5840, St. Louis, MO 63134 USA.

## Trademarks

ComWheel, Datex-Ohmeda S/5, Datex-Ohmeda AS/3, Datex-Ohmeda CS/3, Light, EarSat, FingerSat and Flexlite are trademarks of Instrumentarium Corp.

## Storage and transport

For allowed storage and transport conditions refer to the documentation delivered with the monitor.

All specifications subject to change without notice.

© Instrumentarium Corp. All rights reserved.

---

# TABLE OF CONTENTS

## S/5 Light Monitor Planned Maintenance Instructions

<b>1. Planned Maintenance</b>	<b>1</b>
1.1 Introduction.....	1
1.2 Recommended tools and accessories.....	1
1.3 Recommended parts .....	1
<b>2. Instructions</b>	<b>2</b>
2.1 Visual inspection .....	2
2.2 General functional inspection.....	3
2.3 Screen setup .....	4
2.4 Hemodynamic tests .....	4
2.5 Trend test .....	6
2.6 Recorder unit test .....	6
2.7 Network test .....	7
2.8 DataCard test .....	7
2.9 Service Log.....	8
2.10 Electric safety check .....	8
<b>APPENDIX A</b>	<b>9</b>
<b>Planned maintenance form</b>	<b>A-1</b>






# 1. PLANNED MAINTENANCE

## 1.1 Introduction

These instructions include procedures for **planned maintenance (PM)** for Datex-Ohmeda S/5 Light Monitor. The planned maintenance is recommended to be performed once a year after the monitor installation.

The instructions are planned for the maximum functional configuration. Perform the procedures in the ascending order and skip the items that do not correspond to the monitor configuration.

The instructions include a **check form** to be filled in when performing the corresponding procedures.

The symbol  in the instructions means that the performed procedure should be signed in the check form.

All menu selections related to  Datex-Ohmeda products are written in following typeface:

**Monitor Setup - Install/Service** (Password 16-4-34) -  
**Service** (Password 26-23-8) - **Modules - ESTP - ECG**

Menu selections related to other products e.g. simulators are written in following typeface:

1. RESP - WAVE - NORM  
- RATE - 20

## 1.2 Recommended tools and accessories

Tool	Order No.
Patient simulator for ECG, Impedance Resp and BP	-
Pressure manometer	-
Temperature test set	884515
5-lead ECG cable	-
SpO <sub>2</sub> finger probe	SAS-F4
InvBP transducer	-
Adult NIBP cuff	572435
Adult NIBP hose	877235
Infant NIBP hose	877514
Infant NIBP cuff	877407
Screwdriver - Pozidrive- type	

## 1.3 Recommended parts

Part	Order No.	Notes
Fan filter	886841	
Recorder paper	74205	if N-LREC option installed

## 2. INSTRUCTIONS

- Switch the monitor to standby.
- Disconnect all the connection cables from the monitor's rear panel.

### 2.1 Visual inspection

1. Make visual inspection for all external parts of the monitor. Check e.g. that the power cord receptacle is intact in the power adapter.
2. Connect the power cord to the power adapter and check the supply voltage from the power adapter's connector. PIN 1 voltage must be 12.7 V without load (Figure 1). If necessary adjust the 12.7 V with trimmer R23 (Figure 2).

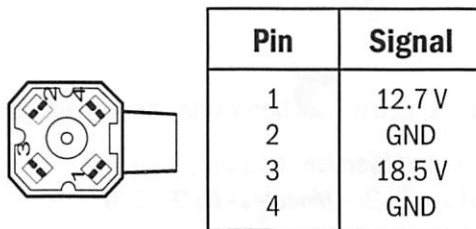


Figure 1 Power adapter's voltages

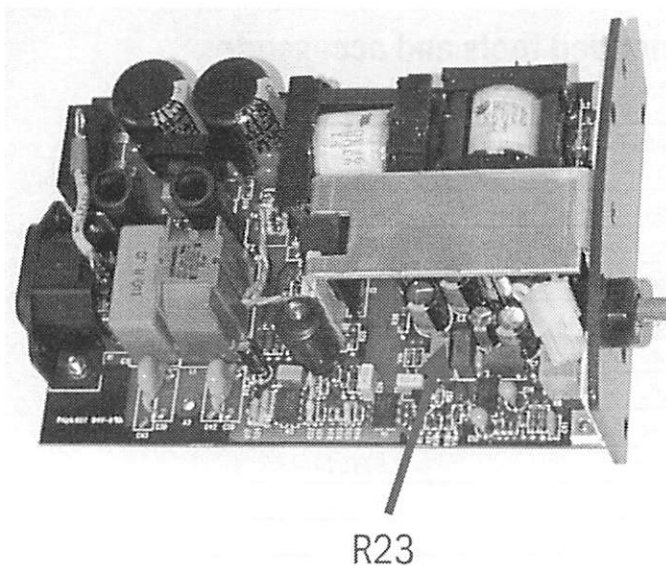
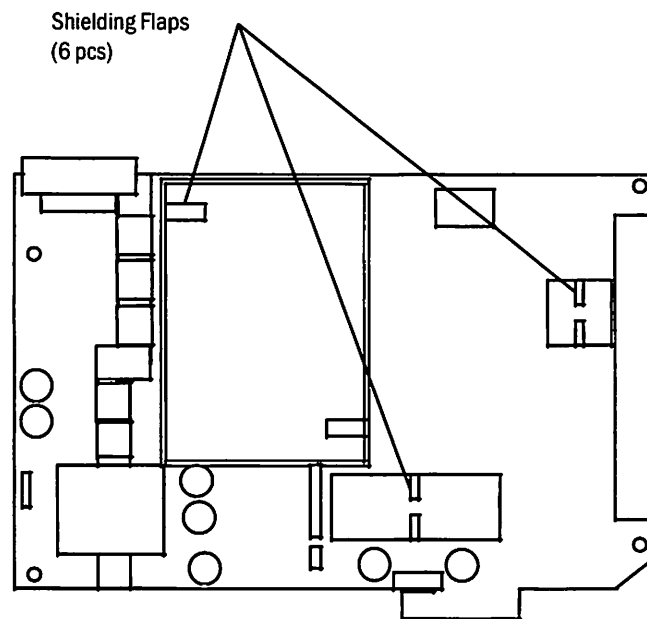


Figure 2 Adjustment trimmer R23 in N-LPOW

3. Clean or replace the fan filter.
4. Clean the recorder unit, if necessary.

5. Check that all shielding flaps (6 pcs) are properly closed. (Figure 3)



**Figure 3 LM1-STP board EMC covers**



## 2.2 General functional inspection

6. Connect the power cord to the power adapter and the power adapter cable to the Light Monitor. Check that the green LED turns on in the power adapter and the LED on the lower right-hand corner of the monitor turns on or starts flashing. Check that both Battery charge status LEDs turn on or start flashing.
7. Switch the monitor on. Check that the monitor starts up properly, i.e.
- both alarm LED's turn on and off
  - the fan starts running
  - the start-up sound is heard from the loudspeaker
  - the normal monitoring screen appears
  - no error messages appear onto the screen \*)
  - if the monitor contains a recorder, two lines of start-up information should be recorded
  - check that the time and date are correct, adjust if necessary
  - if the monitor contains a F-LBAT or N-LBB check that the battery symbol is displayed:



\*) "Check network connectors" will appear if the N-LNET or N-LDNET option is installed.

8. Enter the keyboard menu and select Dummy Press.  
**Monitor Setup - Install/Service** (Password 16-4-34) -  
**Service** (Password 26-23-8) -**Keyboard - Dummy Press**

Press the function keys one by one. Check that each key generates a sound from the loudspeaker and the corresponding text.



## 2.3 Screen setup

Configure the monitor screen according to the monitor configuration so that all necessary parameter information is displayed.

NOTE: The RESP waveform or Digit Field has to be selected on the screen before the respiration measurement can be turned on.

## 2.4 Hemodynamic tests

### ECG measurement tests

9. Enter the ECG service menu and check that the "Timeouts", "Bad checksums" and "Bad c-s by mod" values are not increasing faster than by 50 per second and the ECG/RESP board memories have passed the internal memory test, i.e. "RAM", "ROM" and "EEPROM" all state **OK**.
10. Connect a 5-lead ECG cable to the monitor. Check that the "Cable type" shows 5 lead. If it shows 3 lead, make sure the 5-lead ECG cable being used contains the necessary wiring for cable recognition (pins 0, 8 and 9 connected together).
11. Check that all the electrodes shows **OFF** in the service menu and the message "Leads Off" is shown on the screen.  
Connect the patient simulator and check that all parameter information is displayed as configured on the screen, and that the waveforms correspond to the simulator settings. Switch off the simulator and check that "Asystole" and "Apnea" are displayed.



### Temperature measurement tests

12. Enter the STP service menu and check that the STP board memories have passed the internal memory test, i.e. "RAM", "ROM" and "EEPROM" all show **OK**.
13. Check the temperature calibrations with the temperature test plugs. Calibrate if necessary.
14. Check that the protection for temperature calibration is on:

“Protect key” text in the menu should state **OFF**  
“Protect mode” text should state **ON**.



## Non invasive blood pressure measurement tests

15. Enter the NIBP service menu and check that the NIBP board memories have passed the internal memory test, i.e. “RAM”, “ROM” and “EEPROM” all show **OK**.
16. Check the NIBP tubing system for leakages in **Calibrations - Active Leak Test** menu. The pressure must not drop more than 6 mmHg per one minute.
17. Check the NIBP calibration with 200mmHg pressure and calibrate if necessary.
18. Check the Watchdog timer activation pressure in the **Pneumatics** service menu. The audible signal must activate at 11..15 mmHg pressure. If necessary adjust the limit with the trimmer on the NIBP board.

NOTE: If the limit was adjusted, recalibration is needed.

19. Check the NIBP watchdog timer in the **Watchdog** service menu in the infant mode. The time for the infant test should be 60-70 seconds.
20. Check the safety valve functions in the **Safety Valve** service menu.

NOTE: Make sure the pressure manometer can be used to measure pressures over 300 mmHg. If such a pressure manometer is not available, perform the check with an adult cuff that is wrapped around some round object, for example a calibration gas bottle.

The pressure values “Max press” and “2 s after stop” for both transducers should be within 290 - 330 mmHg for **Adult** and 154 - 165 mmHg for **Infant**.

21. Connect an infant cuff to the monitor, start the measurement and check that the infant cuff is identified correctly. Cancel the measurement.
22. Attach an adult NIBP cuff onto your arm and perform one NIBP measurement. Check that the module identifies the cuff, i.e. the text “Adult” appears in the NIBP digit field for a short time. Check that the monitor gives a reasonable measurement result.



## SpO<sub>2</sub> measurement tests

23. Check that the message “No probe” is displayed when no SpO<sub>2</sub> sensor is connected. Connect a SpO<sub>2</sub> finger probe to the monitor and check that the message “Probe off” is displayed when the probe is not connected to a finger.
24. Attach the SpO<sub>2</sub> sensor to your finger and check that after the message “Pulse search” the pleth

waveform is displayed and the SpO<sub>2</sub> value is in expected range.

Check that the HR value is calculated from SpO<sub>2</sub> when ECG and InvBP (P1) cables are not connected.

25. Remove the SpO<sub>2</sub> sensor from your finger and check that the message “Probe off” is displayed. Disconnect the sensor from the monitor and check that “No probe” message is displayed.



### **Invasive blood pressure measurement tests**

26. Check the InvBP channels with a patient simulator. The values and waveforms should correspond to the simulator settings.

Note: In case you evaluate the measurement accuracy with the simulator, add simulator's accuracy specification to the one of the monitor.



### **Mainstream CO<sub>2</sub> test**

27. Enter the CO<sub>2</sub> service menu and check that the “Timeouts”, “Bad checksums” and “send queue full” values are not increasing faster than by 50 per second.

28. Check that the message “No CO<sub>2</sub> sensor” is displayed when there is no CO<sub>2</sub> sensor connected. Connect a CO<sub>2</sub> sensor to the monitor and check that the message “warming” is displayed.

29. Wait until the “warming” message disappears and the CO<sub>2</sub> value appears to the screen. Breathe at least 5 times to the CO<sub>2</sub> sensor adapter and make sure that the measured values are reasonable and the Respiratory value is calculated.

30. Perform the CO<sub>2</sub> calibration check if necessary.



## **2.5 Trend test**

31. Check that the monitor is capable of storing the trend information and temporary settings over 2 minute standby.



## **2.6 Recorder unit test**


32. Open the paper compartment cover. Check that the message ‘Recorder: Cover open’ appears on the screen, then close the cover.

33. Push the "Recorder Start/Stop" button on the recorder unit and check that the recorder starts recording the selected waveforms. Push the button again to stop recording. Check that the quality of the recordings is acceptable.



## 2.7 Network test

34. Check that the Mon-Net cable connector and the Identification plug are clean and intact, then connect them to the monitor.

35. Check that the monitor connects to the Datex-Ohmeda Network, i.e. the network symbol  is displayed on the upper right-hand corner of the screen.

A message regarding the connection to Datex-Ohmeda Central should appear in the message field on the screen.

36. Check in the **Monitor - Communication** service menu that:


- the "location ID number" matches with the ID plug connected to X3
- the packets and bytes IN is increasing slowly
- the packets and bytes OUT is increasing fast
- "connections" shows the names of the connected networks
- the counters for data errors ("CRC", "Frame", "Transm.") are stable

NOTE: The counters may show values greater than 0. However, any values increasing continuously indicates a problem.

37. Check that the counters for hardware errors ("Intern.", "Missed", "FIFO", "Overrun") all show 0.



## 2.8 DataCard test

Insert a DataCard labeled "Data" in the DataCard slot. Check that the message "Data Card inserted" appears onto the message field and the DataCard symbol  is displayed on the upper right-hand corner of the monitor.



## 2.9 Service Log

38. Check the **Service Log** for possible problems. If the monitor contains recorder unit, record the Service Log onto the recorder by selecting **Record Log**.
39. Clear the content of the Service Log by selecting **Reset Log** from the menu.



## 2.10 Electric safety check

40. Perform the electrical safety check and leakage current test.
41. Check that the monitor functions normally after the performed electrical safety check.
42. Switch the monitor to standby, disconnect the power cord and perform final cleaning.
43. Fill in all necessary documents.





**APPENDIX A**



# PLANNED MAINTENANCE FORM

## Datex Ohmeda S/5™ Light Monitor

Customer	
Service	
Service engineer	
Date	

### Monitor configuration

Monitor model: F-LM1	<input type="checkbox"/>	Model with 2 InvBP measurements, F-LMP1	<input type="checkbox"/>
----------------------	--------------------------	---	--------------------------

Parameter measurement options		Data collecting and data management options		
N-LCM	Mainstream CO <sub>2</sub>	<input type="checkbox"/>	N-LREC Recorder	<input type="checkbox"/>
N-LNSAT	Nellcor SpO <sub>2</sub>	<input type="checkbox"/>	N-LNET Network	<input type="checkbox"/>
			N-LDATA DataCard	<input type="checkbox"/>
			N-LDNET DataCard + Network	<input type="checkbox"/>

OK = Test OK      N.A. = Test not applicable      Fail = Test Failed

	OK	N.A.	Fail
2.1. Visual inspection	<input type="checkbox"/>	<input type="checkbox"/>	<input type="checkbox"/>
2.2. General functional inspection	<input type="checkbox"/>	<input type="checkbox"/>	<input type="checkbox"/>
2.3. Screen setup	<input type="checkbox"/>	<input type="checkbox"/>	<input type="checkbox"/>
2.4. Hemodynamic tests	<input type="checkbox"/>	<input type="checkbox"/>	<input type="checkbox"/>
ECG	<input type="checkbox"/>	<input type="checkbox"/>	<input type="checkbox"/>
Temperature	<input type="checkbox"/>	<input type="checkbox"/>	<input type="checkbox"/>
Non Invasive	<input type="checkbox"/>	<input type="checkbox"/>	<input type="checkbox"/>
SpO <sub>2</sub>	<input type="checkbox"/>	<input type="checkbox"/>	<input type="checkbox"/>
Invasive	<input type="checkbox"/>	<input type="checkbox"/>	<input type="checkbox"/>
CO <sub>2</sub>	<input type="checkbox"/>	<input type="checkbox"/>	<input type="checkbox"/>

	OK	N.A.	Fail
2.5. Trend test	<input type="checkbox"/>	<input type="checkbox"/>	<input type="checkbox"/>
2.6. Recorder unit test	<input type="checkbox"/>	<input type="checkbox"/>	<input type="checkbox"/>
2.7. Network test	<input type="checkbox"/>	<input type="checkbox"/>	<input type="checkbox"/>
2.8. DataCard test	<input type="checkbox"/>	<input type="checkbox"/>	<input type="checkbox"/>
2.9. Service Log	<input type="checkbox"/>	<input type="checkbox"/>	<input type="checkbox"/>
2.10. Electric safety check	<input type="checkbox"/>	<input type="checkbox"/>	<input type="checkbox"/>

**Notes**

\_\_\_\_\_

\_\_\_\_\_

\_\_\_\_\_

**Used spare parts**

Fan filter  Recorder paper

**Signature**

\_\_\_\_\_

# CPU

Datex-Ohmeda, Inc.  
P.O. Box 7550, Madison  
WI 53707-7550, USA  
Tel. +1-608-221-1551  
Fax +1-608-222-9147  
[www.us.datex-ohmeda.com](http://www.us.datex-ohmeda.com)

Datex-Ohmeda Division,  
Instrumentarium Corp.  
P.O. Box 900, FIN-00031  
DATEX-OHMEDA, FINLAND  
Tel. +358 10 39411 Fax +358 9 146 3310  
[www.datex-ohmeda.com](http://www.datex-ohmeda.com)  
© Instrumentarium Corp. All rights reserved.

---

# TABLE OF CONTENTS

## CPU

<b>1</b>	<b>FUNCTIONAL DESCRIPTION</b>	<b>1</b>
1.1	General .....	1
1.1.1	386EX processor (D8).....	2
1.1.2	Real time clock and battery back-up RAM (D15) .....	3
1.1.3	Serial controller, UART (D19).....	3
1.1.4	Audio generator (D6, D14, N4).....	3
1.1.5	Display controller (D1).....	3
1.1.6	ROM (D18, D21) .....	3
1.1.7	RAM (D4-D7) .....	3
1.1.8	Loading a new main software .....	3
1.2	Connectors and signals.....	4
1.2.1	Display connector (X1).....	4
1.2.2	CO <sub>2</sub> connector (X2) .....	5
1.2.3	JTAG connector (X3).....	5
1.2.4	ISA bus connector (X4) .....	6
1.2.5	Loudspeaker connector (X5) .....	8
1.2.6	Power supply board connector (X6) .....	9
1.2.7	Recorder connector (X7) .....	10
1.2.8	Module bus connector (X8) .....	11
<b>2</b>	<b>SERVICE PROCEDURES</b>	<b>13</b>
2.1	General service information.....	13
2.2	Replacing the real time clock battery .....	13
2.3	Replacing the CPU board .....	14
<b>3</b>	<b>TROUBLESHOOTING</b>	<b>15</b>
3.1	Troubleshooting flowchart .....	15
3.2	Troubleshooting chart .....	16
3.3	Error messages.....	16
<b>4</b>	<b>SERVICE MENU</b>	<b>17</b>



# 1 FUNCTIONAL DESCRIPTION

## 1.1 General

The CPU board performs the central data processing of the Light Monitor.

The operating principle of the CPU board is illustrated in figure 1. The CPU board is based around an embedded 386EX processor. Additionally, the CPU board includes a real time clock, battery back-up RAM, serial controller, audio generator, D/A converter and display controller connected to the external processor bus.

The CPU board includes two flash memory circuits. One of the circuits contains the boot code and the other contains the main software code. The CPU board also includes 4 MB dynamic RAM.

The display, recorder and loudspeaker are all connected directly to the CPU board. The ESTP and NIBP board are connected to the CPU board via the power supply board.

There is also an ISA connector for PC/E board (PCMCIA & Ethernet board).

The CPU board uses 3.3 V, 5 V and 12 V operating voltages.

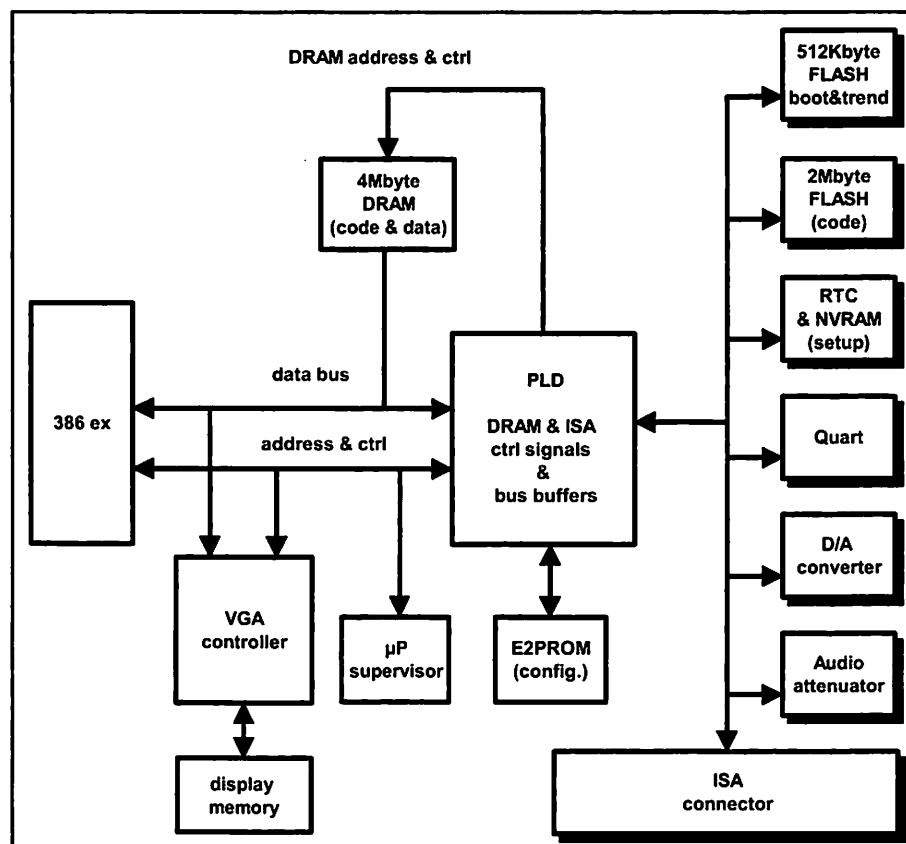


Figure 1 CPU board block diagram



### 1.1.1 386EX processor (D8)

The 386EX processor is based on a 386SX core. Additionally the processor includes the following features:

#### Programmable chip select lines

- Boot block flash
- Code flash
- DRAM
- Real time clock
- Audio generator
- Serial controller
- DAC

#### Interrupt controller

- Serial controller
- ISA connector

#### Timer/counter

- Audio generator

#### I/O lines

- Code Program enable
- Parameter Unit reset
- Nurse call
- Recorder reset
- Defibrillator synchronization
- Watchdog Refresh
- CO<sub>2</sub> shutdown

#### Serial controller

- Parameter Unit bus
- Recorder

#### Bus interface unit

#### Refresh unit

- DRAM refresh

### 1.1.2 Real time clock and battery back-up RAM (D15)

The real time clock is a surface mounted circuit with a removable battery backup. The clock integrates 32 kbyte RAM containing the monitor setup. The battery lifetime is approximately 7 years.



**CAUTION** Discard lithium battery according to local regulations.

### 1.1.3 Serial controller, UART (D19)

The serial controller is a four channel UART used for serial communication with the following units:

- Serial I/O
- CO<sub>2</sub> Unit
- Power supply unit

### 1.1.4 Audio generator (D6, D14, N4)

The audio frequency signal is generated by a timer integrated to the processor. The signal is first attenuated and then transmitted to the output amplifier.

### 1.1.5 Display controller (D1)

The display controller is a single chip controller connected directly to the external processor bus. A 256k × 16 DRAM circuit (D2) is used as display memory. The memory is directly connected to the display controller. Display controller drives the electroluminescence display (EL) and the external VGA-CRT connector simultaneously.

### 1.1.6 ROM (D18, D21)

The ROM consists of two flash memory circuits. One of the circuits contains the boot code and the nonvolatile trends memory, the other contains the main software code. The main software can be reloaded through the serial I/O.

### 1.1.7 RAM (D4-D7)

The RAM consists of 2 × 16 M DRAM circuits controlled by a PLD circuit. The address bus is multiplexed for the RAS and CAS addresses.

### 1.1.8 Loading a new main software

The main software is loaded with a PC connected to the serial I/O connector. The main software code is transmitted from the PC memory to the CPU board. The program is stored into the flash memory. The loading takes approximately 5 minutes when 115 kbps transfer rate is used.

## 1.2 Connectors and signals

### 1.2.1 Display connector (X1)

Pin	Signal	I/O	Description
1	+12VDIS	0	+12V Supply voltage for the display
2	+12VDIS	0	- " -
3	+5VDIS	0	+5V Supply voltage for the display
4	+5VDIS	0	+5V Supply voltage for the display
5	BLANK#	0,TTL	Not connected
6	GNDDIS	-	Ground
7	NC	-	Not connected
8	GNDDIS	-	Ground
9	VSYNC	0,TTL	Vertical Sync
10	GND	-	Ground
11	HSYNC	0,TTL	Horizontal Sync
12	GND	-	Ground
13	VCLK	0,TTL	Video Clock
14	GND	-	Ground
15	VDATA	0,TTL	Video Data
16	GND	-	Ground

### 1.2.2 CO<sub>2</sub> connector (X2)

CO<sub>2</sub> connector is for Pryon's CO<sub>2</sub>sensor.

Pin	Signal	I/O	Description
1	Shutdown	0, TTL	Control of the isolation power supply
2	RXDCO2	I, TTL	Serial receiving
3	TXDCO2	0, TTL	Serial transmission
4	+5V	0	+5V Supply
5	GND	-	Ground
6	+12V	0	+12V Supply
7	WTP#	na	Water Trap Present
8	GND	-	Ground

### 1.2.3 JTAG connector (X3)

Pin	Signal	I/O	Description
1	TDI	I	Test Data Input
2	TDO	0	Test Data Output
3	TMS	I	Test Mode Select
4	TCK	I	Test Clock Input
5	GND	-	Ground
6	Test RST	I	Test Reset
7	+5VD	0	+5V supply
8	NC	-	Not connected

**1.2.4 ISA bus connector (X4)**

<b>A</b>	<b>Signal</b>	<b>I/O</b>	<b>Description</b>	<b>B</b>	<b>Signal</b>	<b>I/O</b>	<b>Description</b>
1	AEN	0	1 = Access cycle, 0 = Transfer cycle	1	+5VA	0	+5V Analog
2	BALE	0	Addr Latch Enable	2	GND A	-	Analog gnd
3	IOCHRDY	I	Wait state needed	3	+5V	0	+5V Supply
4	IOCS16#	0	Accessed recourse is 16bits	4	+5V	0	+5V Supply
5	MEMCS16#	0	Accessed recourse is 16bits	5	GND	-	Ground
6	IOR#	0	I/O Read	6	+3.3V	0	+3.3V Supply
7	IOW#	0	I/O Write	7	+3.3V	0	+3.3V Supply
8	SBHE#	0	Valid data on data 8-15	8	GND	-	Ground
9	MEMR#	0	16 Megabyte read	9	+12V	0	+12V Supply
10	MEMW#	0	16 Megabyte write	10	+12V	0	+12V Supply
11	LA23	0	16 Mega memory address	11	GND	-	Ground
12	LA22	0	-"	12	SMEMR#	0	First 1 mega read
13	LA21	0	-"	13	SMEMW#	0	First 1 mega write
14	LA20	0	-"	14	GND	-	Ground
15	SA19	0	First 1Mega address (memory & I/O)	15	RESET	0	Positive reset
16	SA18	0	-"	16	RESET#	0	Negative reset
17	SA17	0	-"	17	GND	-	Ground
18	SA16	0	-"	18	CLK14M	0	14.318 MHz
19	SA15	0	-"	19	IRQ1	I	Interrupt
20	SA14	0	-"	20	GND	-	Ground
21	SA13	0	-"	21	IRQ5	I	Interrupt
22	SA12	0	-"	22	REFRESH #	0	Refr. cycle
23	SA11	0	-"	23	GND	-	Ground
24	SA10	0	-"	24	NOWS#	I	0 wait state
25	SA9	0	-"	25	IDCS1	0	Ethernet ID Chip Select

A	Signal	I/O	Description	B	Signal	I/O	Description
26	SA8	0	-"	26	GND	-	Ground
27	SA7	0	-"	27	IDCLK	0	Ethernet ID data clock
28	SA6	0	-"	28	IDDI	1	Ethernet ID data input
29	SA5	0	-"	29	GND	-	Ground
30	SA4	0	-"	30	IDDO	0	Ethernet ID data output
31	SA3	0	-"	31	IDPE	0	Ethernet ID prg enable
32	SA2	0	-"	32	GND	-	Ground
33	SA1	0	-"	33	IRQ7		Interrupt
34	SA0	0	-"	34			
35	SD15	1/0	Data	35	GND	-	Ground
36	SD14	1/0	Data	36			
37	SD13	1/0	Data	37			
38	SD12	1/0	Data	38	GND	-	Ground
39	SD11	1/0	Data	39			
40	SD10	1/0	Data	40			
41	SD9	1/0	Data	41	GND	-	Ground
42	SD8	1/0	Data	42			
43	SD7	1/0	Data	43			
44	SD6	1/0	Data	44	GND	-	Ground
45	SD5	1/0	Data	45			
46	SD4	1/0	Data	46			
47	SD3	1/0	Data	47	GND	-	Ground
48	SD2	1/0	Data	48			
49	SD1	1/0	Data	49			
50	SD0	1/0	Data	50	GND	-	Ground

### 1.2.5 Loudspeaker connector (X5)

Pin	Signal	I/O	Description
1	Audio +	0	Audio signal to loudspeaker
2	Audio -	0	Audio signal to loudspeaker

**1.2.6 Power supply board connector (X6)**

<b>A</b>	<b>Signal</b>	<b>I/O</b>	<b>Description</b>	<b>B</b>	<b>Signal</b>	<b>I/O</b>	<b>Description</b>
1	RSTOUT	0,TTL	CPU reset out	1	NC	-	
2	NC	-		2	NC	-	
3	RESETC#	1,TTL	CPU RESET	3	NCALL	0, CMOS	NurseCall
4	TXDPWR	0,TTL	Data from CPU	4	DSYNC	0, CMOS	DefibSync -pulse
5	RXDPWR	1,TTL	Data to CPU	5	485	I/O	Module bus
6	ANOUT0	0,±5V	Analog output, channel 0	6	485#	I/O	Module bus
7	ANOUT1	0,±5V	Analog output, channel 1	7	RST_485	0, CMOS	Module bus reset
8	ANOUT2	0,±5V	Analog output, channel 2	8	GND	-	Ground
9	ANOUT3	0,±5V	Analog output, channel 3	9	GND	-	- " -
10	TXDEXT	0, CMOS	Data from monitor	10	GND	-	- " -
11	RXDEXT	1,TTL	Data to monitor	11	GND	-	- " -
12	RTSEXT#	0, CMOS	Handshaking	12	GND	-	- " -
13	CTSEXT#	1,TTL	Handshaking	13	GND	-	- " -
14	+3.3VD	-	3.3V supply	14	GND	-	- " -
15	+3.3VD	-	- " -	15	GND	-	- " -
16	+3.3VD	-	- " -	16	GND	-	- " -
17	+5VD	-	5V supply	17	GND	-	- " -
18	+5VD	-	- " -	18	GND	-	- " -
19	+5VD	-	- " -	19	GND	-	- " -
20	+5VD	-	- " -	20	GND	-	- " -
21	+12VD	-	12V supply	21	GND	-	- " -
22	+12VD	-	- " -	22	GND	-	- " -
23	+12VD	-	- " -	23	GND	-	- " -
24	+12VD	-	- " -	24	GND	-	- " -
25	+12VD	-	- " -	25	GND	-	- " -



**1.2.7 Recorder connector (X7)**

<b>A</b>	<b>Signal</b>	<b>I/O</b>	<b>Description</b>	<b>B</b>	<b>Signal</b>	<b>I/O</b>	<b>Description</b>
1	NC		Not connected	1	NC		Not connected
2	RXDREC	I,TTL	Serial receive	2	NC		-"
3	NC		Not connected	3	NC		-"
4	+5VREC	0	Voltage supply for the recorder	4	NC		-"
5	+5VREC	0	Voltage supply for the recorder	5	NC		-"
6	GNDREC	-	Recorder ground	6	NC		-"
7	GNDREC	-	-"	7	NC		-"
8	GNDREC	-	-"	8	NC		-"
9	GNDREC	-	-"	9	NC		-"
10	TXDREC	O,TTL	Serial transmit	10	NC		Not connected
11	CTSREC#	I,TTL	Clear to send	11	RED	0	Analog 0,7Vpp
12	GNDREC	-	Recorder ground	12	GREEN	0	Analog 0,7Vpp
13	RSTREC#	O,TTL	Recorder reset	13	BLUE	0	Analog 0,7Vpp
14	GNDREC	-	Recorder ground	14	NC		Reserved
15	GNDREC	-	Recorder ground	15	GNDDCRT	-	Digital ground
16	SYNC	NC	Not connected	16	GNDACRT	-	Analog ground
17	GNDREC	-	Recorder ground	17	GNDACRT	-	Analog ground
18	RTSREC#	O,TTL	Request to send	18	GNDACRT	-	Analog ground
19	+12VREC	0	Voltage supply for the recorder	19	PLUG	NC	Not connected
20	+12VREC	0	-"	20	GNDDCRT	-	Digital ground
21	+12VREC	0	-"	21	NC		Reserved
22	+12VREC	0	-"	22	NC		Reserved
23	+12VREC	0	-"	23	HSYNC	O,TTL	Horisontal sync
24	+12VREC	0	-"	24	VSYNC	O,TTL	Vertical sync
25	+12VREC	0	-"	25	NC		Reserved

All ISA-bus signals are of TTL level except interrupts IRQ1, IRQ5, and IRQ7, and ISA control signals IOCHRDY, IOCS16#, and MEMCS16#, that are of Open Collector type.

### 1.2.8 Module bus connector (X8)

The NIBP-, ECG-, and STP-units are connected to module bus connector.

Pin	Signal	I/O	Description
1	+12VMOD	0	+12V module voltage
2	+12VMOD	0	+12V module voltage
3	GNDMOD	-	Ground
4	-	-	Reserved
5	-	-	Reserved
6	-	-	Reserved
7	GND	0, CMOS	Ground
8	ESTPCLK	Nc	ECG/STP clock
9	GNDMOD	-	Ground
10	+5VMOD	0	+5V module voltage
11	TXDMOD	0, CMOS	Transmission line to ECG, STP and NIBP
12	RXDMOD	I,TTL	Receive line from ECG, STP and NIBP
13	RESETM#	0, CMOS	reset line to modules
14	GNDMOD	-	Ground
15	WTP#	Na	Water Trap Present
16	GND	-	Ground



## 2 SERVICE PROCEDURES

### 2.1 General service information

Field service of the CPU is limited to replacing a faulty circuit board or a real time clock battery. The boards should be returned to Datex-Ohmeda for repair.

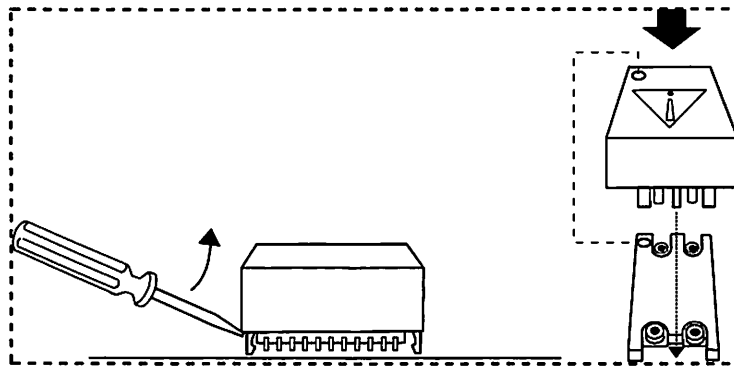
Datex-Ohmeda is always available for service advice. Please provide the monitor serial number, full type designation and a detailed fault description.

**CAUTION** Only trained personnel with the appropriate tools and equipment should perform the tests and repairs outlined in this section. Unauthorized service may void warranty of the unit.

### 2.2 Replacing the real time clock battery

Replace the real time clock battery according to the following procedures. Refer to the exploded view, chapter 10.

1. Disconnect the CPU board (see exploded views).
2. Carefully detach the battery (part 22) from the D12 circuit using a screwdriver. Locate the new battery.



**Figure 2** Detaching the battery and the battery location

3. Replace the rear cover and the chassis cover.
4. Enter **Monitor Setup - Install/Service** (password 16-4-34) - **Service View** (password 26-23-8) - **Monitor - Configuration**. Choose the correct configuration related to monitor hardware configuration. Perform factory reset.  
NOTE: MS + SS - CO<sub>2</sub> should always be set to "NO".
5. Check that all parameters and possible options (NET, DATA, CO<sub>2</sub>) are working properly.
6. Set time & date (*Monitor Setup - Set Time and Date*) and make user configurations.
7. Turn the device off for 5 minutes. Make sure that time and user configurations are OK.

## 2.3 Replacing the CPU board

1. Replace the new CPU board and make sure that all connections are intact correctly.
2. Replace the rear cover and the chassis cover
3. Enter **Monitor Setup - Install/Service** (password 16-4-34) - **Service View** (password 26-23-8) - **Monitor - Configuration**. Choose the correct configuration related to monitor hardware configuration. Perform factory reset.  
NOTE: MS + SS - CO<sub>2</sub> should always be set to "NO".
4. Check that all parameters and possible options (NET, DATA, CO<sub>2</sub>) are working properly.
5. Set time & date (*Monitor Setup - Set Time and Date*) and make user configurations.
6. Turn the device off for 5 minutes. Make sure that time and user configurations are OK.

### 3 TROUBLESHOOTING

#### 3.1 Troubleshooting flowchart

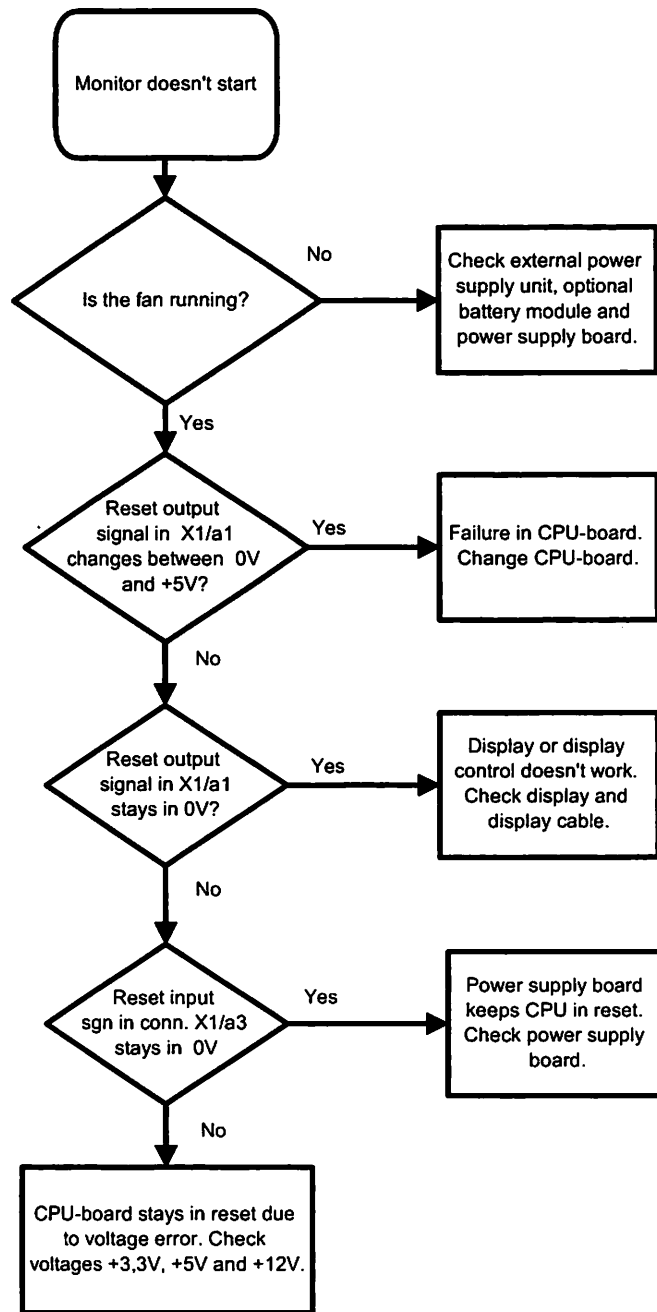


Figure 3 CPU board troubleshooting chart

### 3.2 Troubleshooting chart

TROUBLE	CAUSE	TREATMENT
Real time clock adjustment has been lost	Normal drift	Readjust time
	Battery worn out	Replace battery, adjust real time clock and make user configurations.
User defaults have been lost	Battery worn out	Replace battery, adjust real time clock and make user configurations.

### 3.3 Error messages

TROUBLE	EXPLANATION
SRAM ERROR	Battery back-up SRAM (D12) corrupted. Replace battery.
	Also occurs in first start after main software change. Restart monitor.
EPROM ERROR	Flash memory failure. Replace the CPU board.
RAM ERROR	RAM memory failure. Replace the CPU board.
TREND ERROR	Boot Block Flash memory failure. Replace the CPU board.

## 4 SERVICE MENU

There is no service menu available for the CPU board.





# POWER SUPPLY UNIT

Datex-Ohmeda, Inc.  
P.O. Box 7550, Madison  
WI 53707-7550, USA  
Tel. +1-608-221-1551  
Fax +1-608-222-9147  
[www.us.datex-ohmeda.com](http://www.us.datex-ohmeda.com)

Datex-Ohmeda Division,  
Instrumentarium Corp.  
P.O. Box 900, FIN-00031  
DATEX-OHMEDA, FINLAND  
Tel. +358 10 39411 Fax +358 9 146 3310  
[www.datex-ohmeda.com](http://www.datex-ohmeda.com)  
© Instrumentarium Corp. All rights reserved.

---

# TABLE OF CONTENTS

## POWER SUPPLY UNIT

<b>1</b>	<b>FUNCTIONAL DESCRIPTION</b>	<b>1</b>
1.1	General .....	1
1.2	Voltages .....	1
1.2.1	Input power sources .....	1
1.2.2	Module voltages .....	3
1.3	Connectors on rear panel .....	4
1.3.1	External power supply, X1 .....	5
1.3.2	Serial interface, X2 .....	5
1.3.3	Feature connector, X3 .....	6
1.3.4	Network .....	7
1.3.5	VGA connector, X7 .....	9
1.4	Defibrillator synchronisation output .....	10
<b>2</b>	<b>SERVICE PROCEDURES</b>	<b>11</b>
2.1	General service information .....	11
<b>3</b>	<b>TROUBLESHOOTING</b>	<b>13</b>
3.1	Troubleshooting flowchart .....	13
3.2	Troubleshooting for output voltages .....	14
<b>4</b>	<b>SERVICE MENU</b>	<b>15</b>
4.1	Power menu .....	15
4.1.1	Factory test menu .....	16



# 1 FUNCTIONAL DESCRIPTION

## 1.1 General

The power supply board distributes power to all units in the Light Monitor.

The power source is either an external power adapter, or one of the two rechargeable batteries (optional). If the monitor is used with mains power and the power cord is disconnected, operation continues with batteries without interruption. When the power cord is plugged in again, batteries are recharged automatically.

The external operating voltage must be between 12.3 and 14.5 V. If the voltage drops to 11.8 V, the monitor switches to battery operation or shuts down if there are no batteries connected.

The power supply board converts +12 V main voltage to +3.3 V, 2A and +5 V, 2 A voltages. All voltages have a common ground. If overvoltage occurs in the output, the power supply board turns itself off automatically.

The power supply board reads the status of the keyboard and the ComWheel, and sends the information to the CPU board. Communication takes place on the CMOS-level serial communication line. Only two signals, TXDP and RXDP, are used without handshaking. The communication speed is 9600 bps. The board also drives alarm LEDs according to the messages sent by the CPU board. The power supply board also drives the charge indicator LEDs.

The microprocessor on the power supply board is of the type N87C51FB and the oscillator frequency is 11.059 MHz.

The module and serial I/O buffers are also located on the power supply board.

The nominal voltage of the battery is 13.2 V, capacity 1800 mAh. The nominal voltage of the backup battery is 13.2 V, capacity 800 mAh.

## 1.2 Voltages

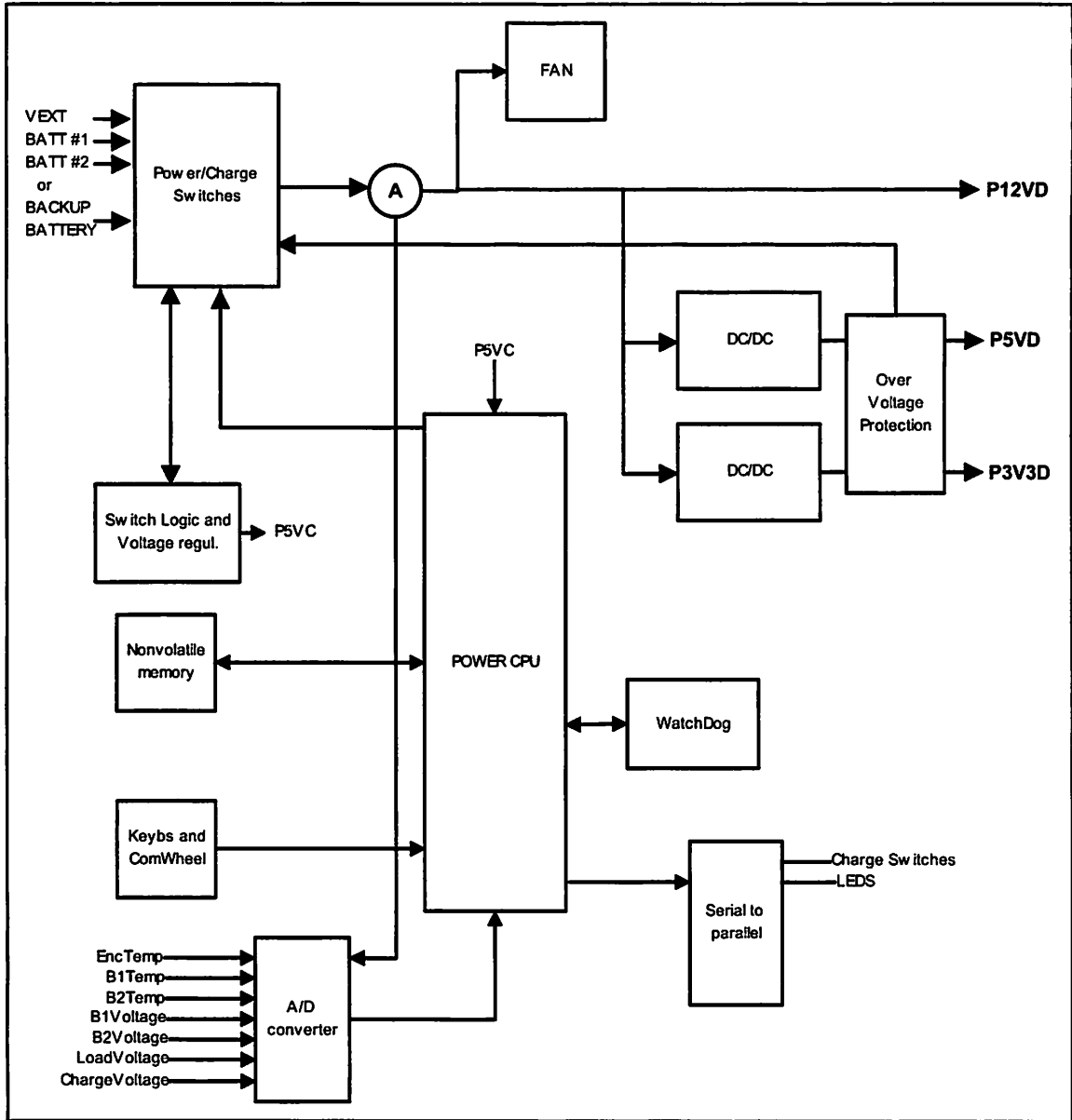
### 1.2.1 Input power sources

The input power sources of the Light Monitor are the external power supply, external vehicle adapter or one of the two NiCd batteries (figure 2). The external power supply and the vehicle adapter are optional with each other so they can't be used simultaneously.

Batteries are charged with the constant current limited by the external power source.

Input voltage requirement: 12.3...14.5 VDC,  $V_{ripp}$  = 200 mV, 2.5 A (min).

Charge input voltage: 18.0...22.0 VDC,  $V_{ripp}$  = 100 mV, current limited to 600 mA  $\pm$  2.5 % (constant current source).



**Figure 1 Power supply board block diagram**

## 1.2.2 Module voltages

+3.3V and +5V module voltages are made from 12 V monitor voltage by switch mode power supply. +12VDC voltage fluctuates according the table module voltages since battery voltage is unregulated.

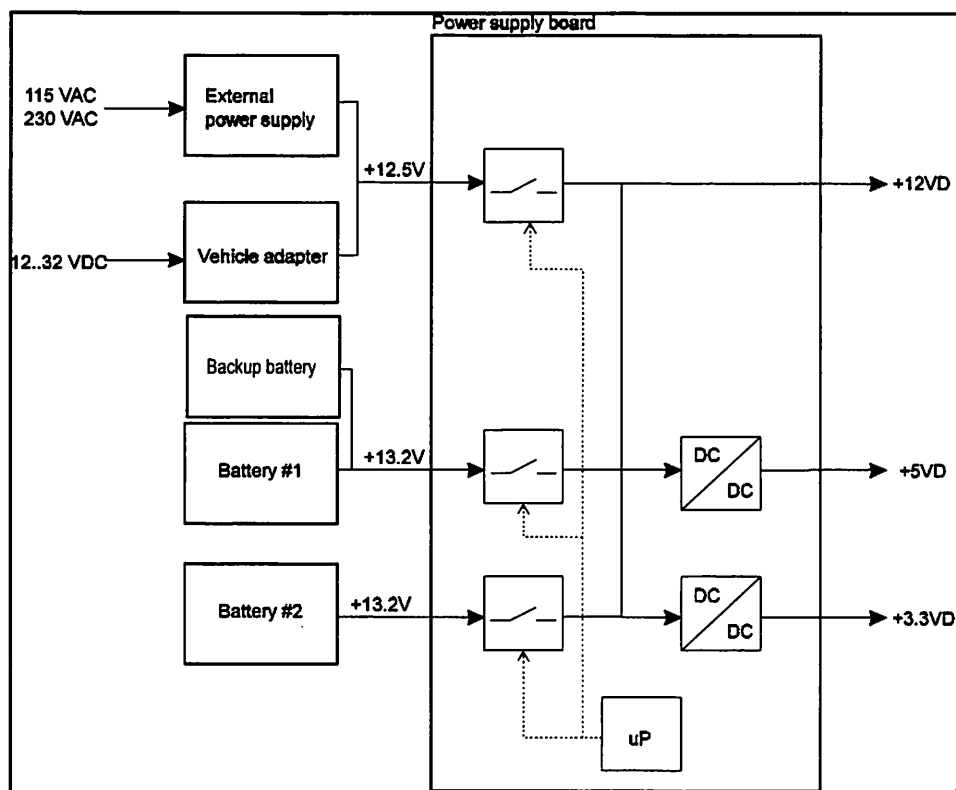


Figure 2 Power supply block diagram

Table 1 Module voltages

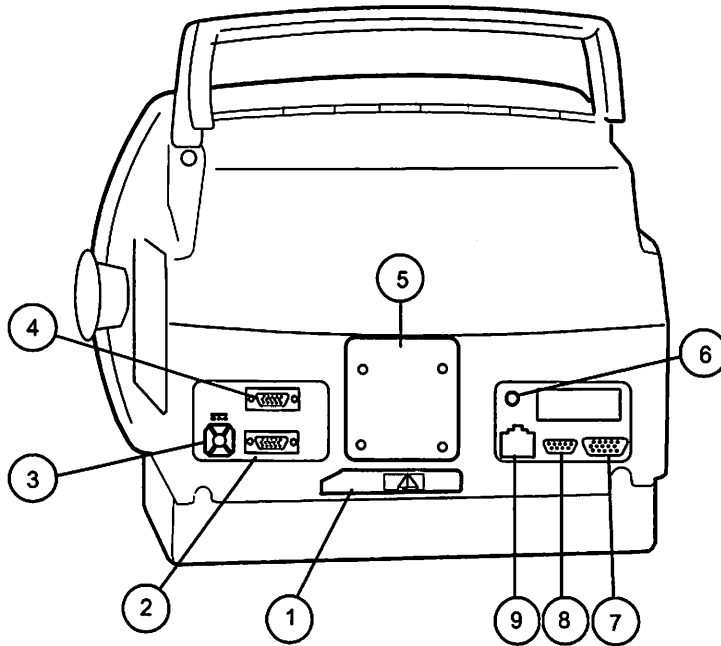
Nom. Voltage	Voltage	Tolerance	Output ripple	I <sub>max</sub>
+12VDC	10.4 ... 14.5 V	not specified	not specified	<sup>1)</sup> 2.8 A
+5VDC	5.05 V	± 3%	typ. 50 mV <sub>pp</sub>	2.0 A
+3.3VDC	3.33 V	± 3%	typ. 50 mV <sub>pp</sub>	2.0 A

<sup>1)</sup> Includes the power consumption of +3.3V and +5V module voltages.


The following parameter units have a 4 kV isolation power supply for patient safety:

- ECG-unit
- STP-unit
- CO<sub>2</sub>-unit

### 1.3 Connectors on rear panel

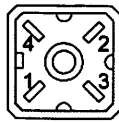


**Figure 3** Rear panel connectors and fittings

- (1) Dust filter 
- (2) Feature connector, X3.
- (3) Connector for power adapter, X1
- (4) Printer connector (serial), X2
- (5) Mounting attachment
- (6) -
- (7) External VGA connector, X7
- (8) Connector for network location ID plug, X6
- (9) Network connector, X5



### 1.3.1 External power supply, X1



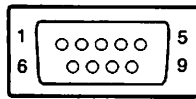
**External power supply connector (front view)**

**External power supply connector pin assignments**

Pin	Signal	Description
1	12V	Monitor voltage
2	gnd	Ground
3	18V	Charge voltage, current limited
4	gnd	Ground

### 1.3.2 Serial interface, X2

The connector provides a RS-232 serial communication link with handshaking.



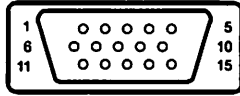
**Pin out of the D9 male connector (front view)**

**RS-232 Serial communication connector pin assignments**

Pin	Signal	I/O	Description
1	N/C	-	-
2	RXD	I	RS-232 data in
3	TXD	O	RS-232 data out
4	+5V	O	+5V output, max 200mA
5	GND	-	Ground
6	N/C	-	-
7	RTS	O	Request to Send
8	CTS	I	Clear To Send
9	N/C	-	-

### 1.3.3 Feature connector, X3

The connector provides module bus output with reset, two analog outputs, defib sync output and Nurse Call -signal with floating relay contact.



Pin out of the high density D15 male connector (front view)

Feature connector pin assignments

Pin	I/O	Signal <sup>1)</sup>	Signal <sup>2)</sup>	Description	Signal levels
1	-	N/C	N/C	-	-
2	I/O	RS485+	RS485+	RS-485 data (AM module bus)	RS-485
3	0	DSYNC	DSYNC	Defib synchronization output	CMOS, active high, I out max 2.5 mA
4	0	P5VD	+5V	+5V output	<sup>3)</sup>
5	0	ANOUT2	ANOUT2	Analog output, ch 2	-5 V .. +5 V
6	I/O	RS485-	RS485-	RS-485 data (AM module bus)	RS-485
7		GNCOEQ	GND	signal ground	-
8	0	NCALL	NCALL	Nurse Call	CMOS, active high, I out max 2.5 mA
9		GNCOEQ	GND	signal ground	
10	0	ANOUT3	ANOUT3	Analog output, ch 3	-5 V .. +5 V
11	-	N/C	N/C	-	-
12	0	485RST#	485RST#	RS-485 module reset	CMOS, active low
13	-	N/C	N/C	-	-
14	0	RLYOPEN	RLYOPEN	NCALL relay, normally open contact	<sup>4)</sup>
15	0	RLYCOM	RLYCOM	NCALL relay, common contact	<sup>4)</sup>

<sup>1)</sup> Actual signal name

<sup>2)</sup> Signal name seen by user

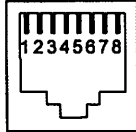
<sup>3)</sup> I<sub>max</sub> = 200 mA

<sup>4)</sup> Relay contacts are potential free. I<sub>max</sub> = 0.5 A, U<sub>max</sub> = 100 VAC/VDC.

## 1.3.4 Network

### 1.3.4.1 Ethernet interface, X5

The ethernet interface meets IEEE 802.3 specifications (10BASE-T) with hospital grade approved power and data transformers.



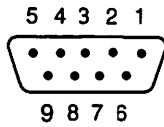
#### Network connector (front view)

##### Ethernet connector pin assignments

Pin	I/O	Signal	Description
1	0	Tx +	Transmit Data
2	0	Tx -	Transmit Data
3	1	Rx +	Receive Data
4		N/C	
5		N/C	
6	1	Rx -	Receive Data
7		N/C	
8		N/C	

### 1.3.4.2 Connector for network location ID plug, X6

The coding element interface is used for bedside address coding for the ethernet. The element is plugged in to the female D-connector of 9-pins.

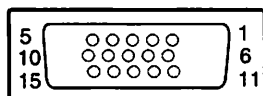


Pin out of the D9 female connector (front view)

Coding element pin assignments

Pin	I/O	Signal	Description	Signal levels
1	0	IDCS1	Chip select	CMOS 5V
2	0	IDCL	Clock	CMOS 5V
3	I	IDDI	Data in	CMOS 5V
4	0	IDDO	Data out	CMOS 5V
5	0	IDPE	Protect enable	CMOS 5V
6	0	P5VD	Vcc for the coding element (non-isolated)	see: module voltages
7	0	ECGOUT	RESERVED, NOT IN USE	
8	0	NCALL	RESERVED, NOT IN USE	
9		gnd	Ground	

### 1.3.5 VGA connector, X7



Pin out of the high density D15 female connector (front view)

The pin assignments of the VGA-connector

Pin	I/O	Signal
1	0	Red
2	0	Green
3	0	Blue
4	-	N/C
5	-	digital gnd
6	-	analog gnd (red)
7	-	analog gnd (green)
8	-	analog gnd (blue)
9	-	N/C
10	-	digital gnd (logic)
11	-	N/C
12	-	N/C
13	0	Horizontal sync.
14	0	Vertical sync.
15	-	N/C

## 1.4 Defibrillator synchronisation output



**Defibrillator synchronisation connector**

**Defibrillator synchronisation connector pin assignments**

Pin	I/O	Signal <sup>1)</sup>	Signal <sup>2)</sup>	Description	Signal levels
1		GNCOEQ	GND	Signal ground	
2	0	DSYNC	DSYNC	Defib. Synchronization output	CMOS, active high, I out max 2.5 mA
3	0	ANOUT0	ECG_OUT		-5 V...+5 V
4	0	ANOUT1	InvBP_OUT		-5 V...+5 V

<sup>1)</sup> Actual signal name

<sup>2)</sup> Signal name seen by user

## 1.5 Analog outputs

There are four separate analog output channels, as default, they all are off.

Channel	Pin	Selection range
1	#3 in Signal Out connector	ECG or test signals
2	#4 in Signal Out connector	P1 or test signals
3	#5 in feature connector	freely selectable
4	#10 in feature connector	freely selectable

## **2 SERVICE PROCEDURES**

### **2.1 General service information**

Field service for the power unit is limited to replacing a faulty circuit board. The board should be returned to Datex-Ohmeda for repair.

Datex-Ohmeda is always available for service advice. Please provide the monitor serial number, full type designation, and a detailed fault description.

**CAUTION** Only trained personnel with the appropriate tools and equipment should perform the tests and repairs outlined in this section. Unauthorized service may void warranty of the unit.





### 3 TROUBLESHOOTING

Before troubleshooting the power supply board, please refer to the general troubleshooting procedures described in part I.

#### 3.1 Troubleshooting flowchart

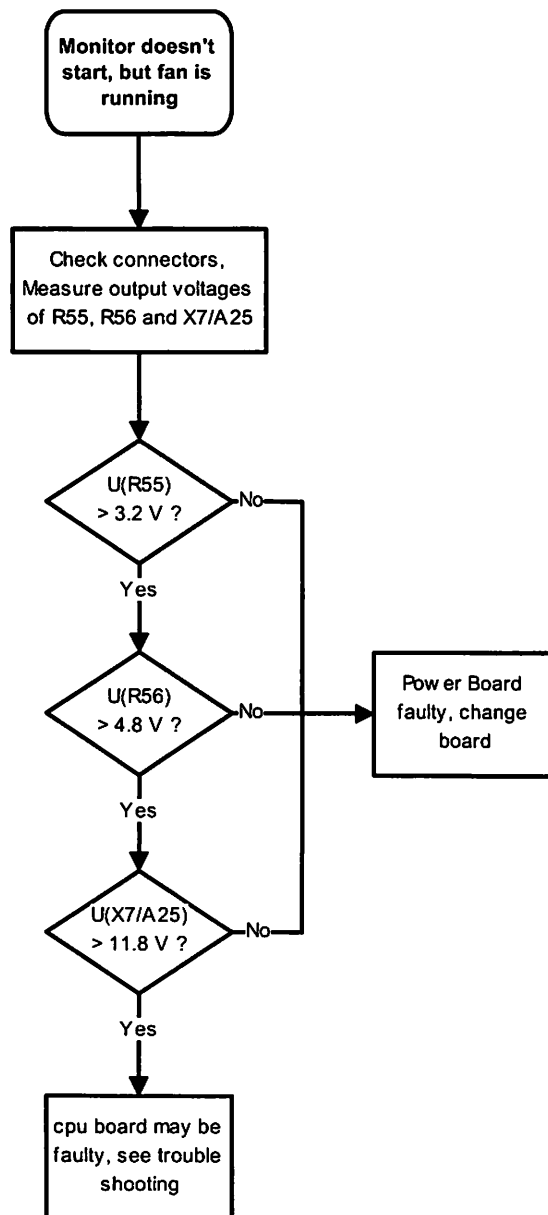


Figure 4 Power supply board troubleshooting flowchart

### 3.2 Troubleshooting for output voltages

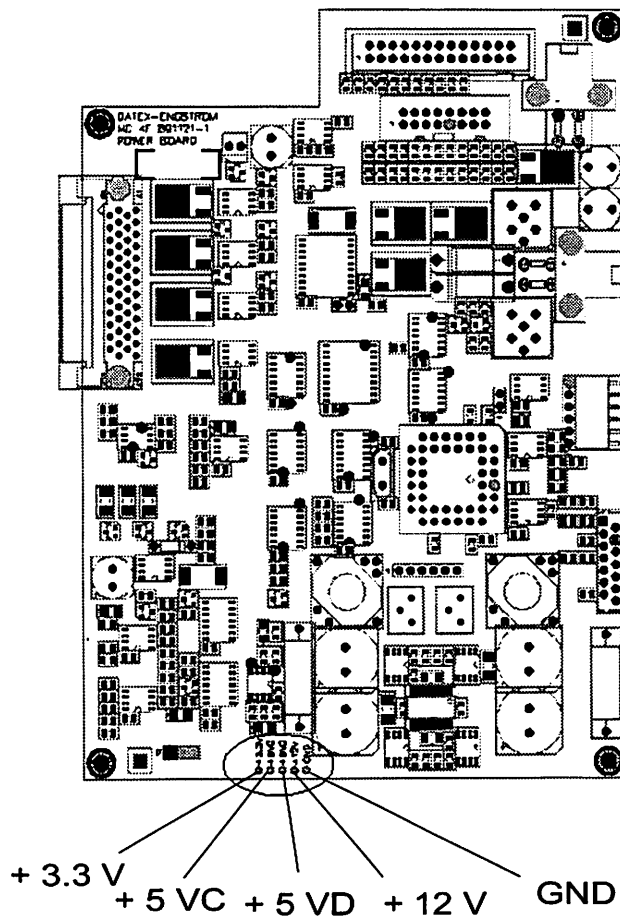



Figure 5 Output voltages on power board

## 4 SERVICE MENU

### 4.1 Power menu

Enter the Power menu according to the following procedures.

1. Press the **Menu** key.
2. Enter **Monitor Setup - Install/Service** (password 16-4-34) - **Service View** (password 26-23-8) - **Modules - Power**.

Power	Power Service
Factory Test  Previous Menu	Batt1 type KR-2800CE Batt2 type KR-2800CE  Batt1 faults -  Batt2 faults -

#### Factory Test

Battery related data (see next page).

#### Power Service

*Batt1 type*      **Batt1 type** indicates battery 1 cell type.

*Batt2 type*      **Batt2 type** indicates battery 2 cell type.

*Batt1 faults*    **Batt1 faults** indicates battery 1 faults.

*Batt2 faults*    **Batt2 faults** indicates battery 2 faults.

### 4.1.2 Factory test menu

Factory Test	Factory Test Data										
Previous Menu	Pow src: BATT 1 Batt 1 / 2 exists 1 / 1 Batt 1 / 2 charging 0 / 0 Battery: module Batt 1/2 status 0h 40h Pow faults 0h  Batt1 temp 0.0 °C Batt2 temp 0.0 °C Enc temp 0.0 °C Batt1 volt 0.00 V Batt2 volt 0.00 V Load volt 0.00 V Charging volt 0.00 V Load current 0.00 A  <table style="width: 100%; border: none;"> <tr> <td></td> <td style="text-align: center;">Batt1</td> <td style="text-align: center;">Batt2</td> </tr> <tr> <td>Batt. last cap</td> <td style="text-align: center;">0.00 Ah</td> <td style="text-align: center;">0.00 Ah</td> </tr> <tr> <td>Batt. used cap</td> <td style="text-align: center;">0.00 Ah</td> <td style="text-align: center;">0.00 Ah</td> </tr> </table> Average voltage 0.00 V  Batt1 cycles 0 Batt2 cycles 0			Batt1	Batt2	Batt. last cap	0.00 Ah	0.00 Ah	Batt. used cap	0.00 Ah	0.00 Ah
	Batt1	Batt2									
Batt. last cap	0.00 Ah	0.00 Ah									
Batt. used cap	0.00 Ah	0.00 Ah									

### Factory Test Data

- Pow src:* **Pow src** indicates present power source: EXT - external power supply, BATT 1 - battery 1, BATT 2 - battery 2.
- Batt 1/2 exists* **Batt 1/2 exists** indicates battery existence: 0 - battery removed, 1 - battery inserted.
- Batt 1/2 charging* **Batt 1/2 charging** indicates charging of battery: 0 - no charging, 1 - charging.
- Battery: module* **Battery module** indicates presence of battery module, Internal - backup battery.
- Batt 1/2 status* **Batt 1/2 status** indicates battery status bits (hexadecimal).
- Pow faults* **Pow faults** indicates power supply board faults (h=hexadecimal).
- Batt1 temp* **Batt1 temp** indicates temperature of battery 1.
- Batt2 temp* **Batt2 temp** indicates temperature of battery 2.
- Enc temp* **Enc temp** indicates temperature of monitor.
- Batt1 volt* **Batt1 volt** indicates cell voltage of battery 1.
- Batt2 volt* **Batt2 volt** indicates cell voltage of battery 1.
- Load volt* **Load volt** indicates voltage of +12 VD line.
- Charging volt* **Charging volt** indicates charging input voltage.
- Load current* **Load current** indicates load current of monitor.

*Batt. last cap*     **Batt. last cap** indicates last measured full capacity of the battery. The capacity is calculated from a battery that is discharged from full to empty.

*Batt. used cap*     **Batt. used cap** indicates capacity discharged from the battery. Remaining capacity: last cap - used cap.

*Average voltage*     **Average voltage** indicates average of the last two load voltage measurements in battery use mode.

*Batt1 cycles*     **Batt1 cycles** indicates number of charging times of battery 1.

*Batt2 cycles*     **Batt2 cycles** indicates number of charging times of battery 2.



**LM-NIBP board**

**LM-ECG board**

**LM-STP board**

Datex-Ohmeda, Inc.  
P.O. Box 7550, Madison  
WI 53707-7550, USA  
Tel. +1-608-221-1551  
Fax +1-608-222-9147  
[www.us.datex-ohmeda.com](http://www.us.datex-ohmeda.com)

Datex-Ohmeda Division,  
Instrumentarium Corp.  
P.O. Box 900, FIN-00031  
DATEX-OHMEDA, FINLAND  
Tel. +358 9 39411 Fax +358 9 146 3310  
[www.datex-ohmeda.com](http://www.datex-ohmeda.com)  
© Instrumentarium Corp. All rights reserved.

---

# TABLE OF CONTENTS

## Hemodynamics boards

<b>TABLE OF CONTENTS</b>	<b>i</b>
<b>TABLE OF FIGURES</b>	<b>ii</b>
<b>Introduction</b>	<b>1</b>
<b>1 Functional Description</b>	<b>3</b>
1.1 Measurement principle .....	3
1.1.1 NIBP .....	3
1.1.2 ECG .....	3
1.1.3 Pulse oximetry .....	3
1.1.4 Temperature .....	6
1.1.5 Invasive blood pressure .....	6
1.1.6 Respiration .....	6
1.2 Main components .....	7
1.2.1 Side panel .....	7
1.2.2 LM-NIBP board .....	8
1.2.3 LM-ECG board .....	11
1.2.4 LM-STP board .....	14
1.3 Connectors and signals .....	19
1.3.1 Module bus connectors .....	19
1.3.2 Patient panel connectors .....	20
1.3.3 Test points .....	21
<b>2 Service Procedures</b>	<b>22</b>
2.1 General service information .....	22
2.2 Service check .....	22
2.3 Adjustments and calibrations .....	34
<b>3 Troubleshooting</b>	<b>38</b>
3.1 Troubleshooting charts .....	38
3.1.2 NIBP Troubleshooting .....	47
3.1.3 LM-STP and LM-ECG board troubleshooting .....	48
<b>4 Service Menu</b>	<b>50</b>
4.1 NIBP service menu .....	51
4.1.1 NIBP calibration menu .....	52
4.1.2 NIBP safety valve menu .....	54
4.1.3 NIBP pulse valve menu .....	55
4.1.4 NIBP pneumatics menu .....	56
4.1.5 NIBP watchdog menu .....	57
4.2 ECG service menu .....	58
4.3 STP service menu .....	59
4.3.2 Calibration menu .....	61
<b>APPENDIX A</b>	<b>1</b>
<b>Preventive maintenance Check Form, LM-NIBP, LM-ECG, LM-STP boards</b>	<b>A-1</b>



## TABLE OF FIGURES

Figure 1	Absorption of infrared light in the finger and finger sensor parts layout and schematic diagram .....	5
Figure 2	Side panel connectors.....	7
Figure 3	LM-NIBP board functional block diagram.....	8
Figure 4	LM-ECG measurement block diagram.....	11
Figure 5	Serial communication and Opto Isolation .....	13
Figure 6	LM-STP board block diagram .....	14
Figure 7	Temperature measurement block diagram.....	15
Figure 8	Pressure transducer working principle .....	16
Figure 9	Pulse oximetry measurement block diagram.....	17
Figure 10	LM-STP board EMC covers .....	23
Figure 11	NIBP troubleshooting flowchart.....	47
Figure 12	LM-STP and LM-ECG board troubleshooting flowchart (continues next page).....	48

## INTRODUCTION

The LM-NIBP, LM-ECG, and LM-STP boards are printed circuit boards that provide general hemodynamic parameters as listed below.

Letters in the board name stand for:

NIBP = Non-Invasive Blood Pressure

ECG = Electrocardiography (+ Impedance Respiration)

S = Pulse oximetry

T = Temperature

P = Invasive Blood Pressure



---

# 1 FUNCTIONAL DESCRIPTION

## 1.1 Measurement principle

### 1.1.1 NIBP

NIBP (Non-Invasive Blood Pressure) is an indirect method for measuring blood pressure.

The NIBP measurement is performed according to the oscillometric measuring principle. The cuff is inflated with a pressure slightly higher than the presumed systolic pressure, and deflated at a speed based on the patient's pulse, collecting data from the oscillations caused by the pulsating artery. Based on these oscillations, values for systolic, mean, and diastolic pressures are calculated.

The following parts are necessary for the NIBP measurement

- NIBP unit
- Twin hose (Adult or Infant model)
- Blood pressure cuffs (different sizes)

### 1.1.2 ECG

Electrocardiography analyzes the electrical activity of the heart by measuring the electrical potential produced with electrodes placed on the surface of the body.

ECG reflects

- Electrical activity of the heart
- Normal/abnormal function of the heart
- Effects of anaesthesia on heart function
- Effects of surgery on heart function

See the User's Reference Manual for electrodes positions and other information.

### 1.1.3 Pulse oximetry

A pulse oximeter measures the light absorption of blood at two wavelengths, one in the near infrared (about 900 nm) and the other in the red region (about 660 nm) of light spectrum. These wavelengths are emitted by LEDs in the SpO<sub>2</sub> sensor, the light is transmitted through peripheral tissue and is finally detected by a PIN-diode opposite to LEDs in the sensor. Pulse oximeter derives the oxygen saturation (SpO<sub>2</sub>) using empirically determined relationship between the relative absorption at the two wavelengths and the arterial oxygen saturation SaO<sub>2</sub>.

In order to measure the arterial saturation accurately, pulse oximeters use the component of light absorption giving variations synchronous with heart beat as primary information on the arterial saturation.

A general limitation of the above pulse oximetry principle is that due to only two wavelengths used only two hemoglobin species can be discriminated by the measurement.

The modern pulse oximeters are empirically calibrated either against fractional saturation  $SaO_2\text{frac}$ ,

$$SaO_2\text{frac} = \frac{HbO_2}{(HbO_2 + Hb + \text{Dyshemoglobin})},$$

or against functional saturation  $SaO_2\text{func}$ ,

$$SaO_2\text{func} = \frac{HbO_2}{(HbO_2 + Hb)},$$

which is more insensitive to changes of carboxyhemoglobin and methemoglobin concentrations in blood.

The oxygen saturation percentage  $SpO_2$  measured by Datex-Ohmeda module is calibrated against the functional saturation  $SaO_2\text{func}$ . The advantage of this method is that the accuracy of  $SpO_2$  measurement relative to  $SaO_2\text{func}$  can be maintained even at rather high concentrations of carboxyhemoglobin in blood. Independent of the calibration method, pulse oximeter is not able to correctly measure oxygen content of the arterial blood at elevated carboxyhemoglobin or methemoglobin levels.

### **Plethysmographic pulse wave**

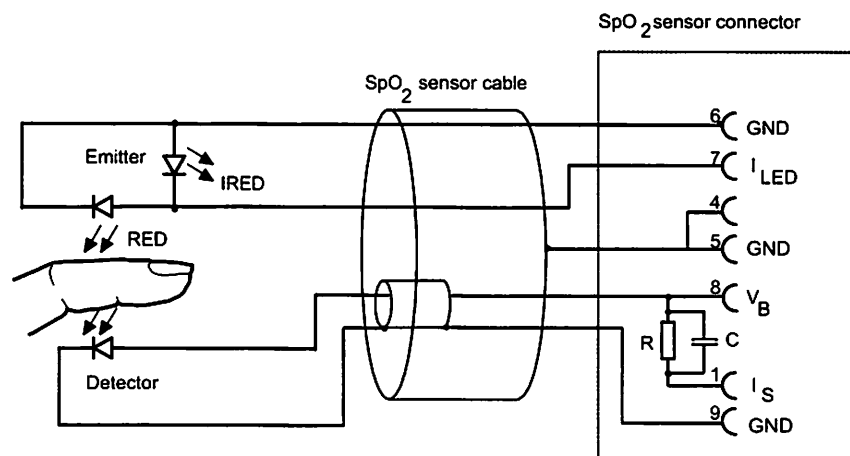
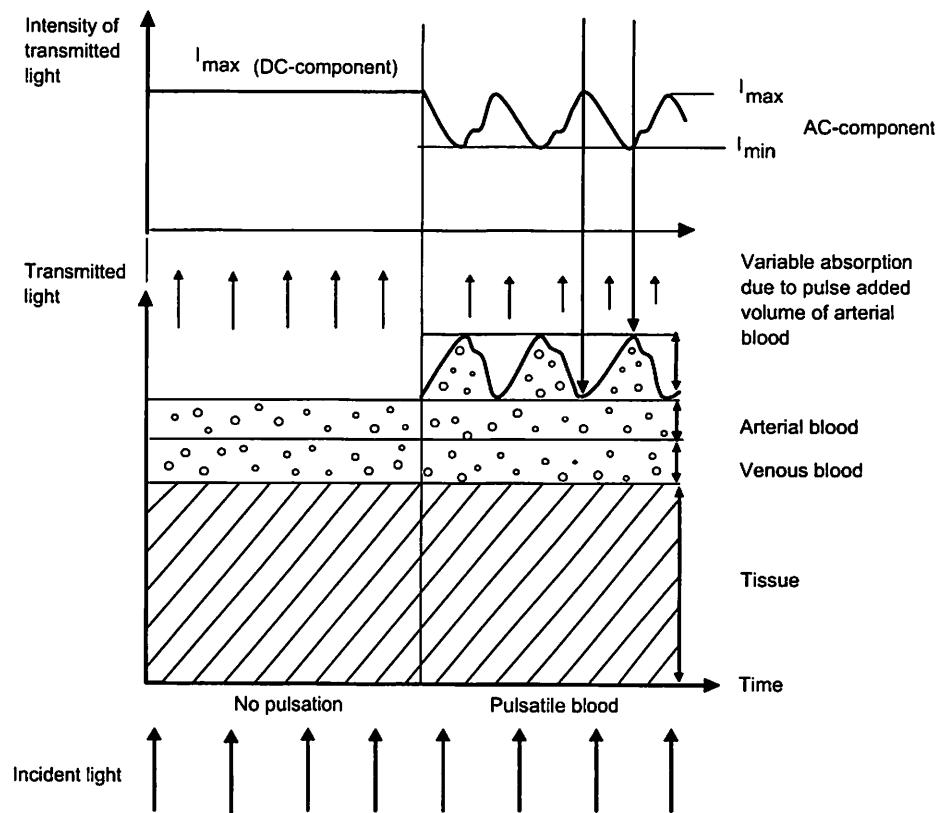
The plethysmographic waveform is derived from the IR signal and reflects the blood pulsation at the measuring site. Thus the amplitude of the waveform represents the perfusion.

### **Pulse rate**

The pulse rate calculation is done by peak detection of the plethysmographic pulse wave. The signals are filtered to reduce noise and checked to separate artifacts.

### **Sensor**

The standard sensor is a finger clamp sensor which contains the light source LEDs in one half and the photodiode detector in the other half. Different kinds of sensors are available from Datex-Ohmeda.



**Figure 1** Absorption of infrared light in the finger and finger sensor parts layout and schematic diagram

### 1.1.4 Temperature

The temperature is measured by a probe whose resistance varies when the temperature changes, called NTC (Negative Temperature Coefficient) resistor.

The resistance can be measured by two complementary methods:

1. Applying a constant voltage across the resistor and measuring the current that flows through it.
2. Applying a constant current through the resistor and measuring the voltage that is generated across it.

In Datex-Ohmeda solution the two methods are combined in a form of a voltage divider. The NTC-resistor is connected in series with a normal resistor and a constant voltage is applied across them. The temperature dependent voltage can be detected at the junction of the resistors, thus producing the temperature signal from the patient. The signal is amplified by analog amplifiers and further processed by digital electronics.

### 1.1.5 Invasive blood pressure

To measure invasive blood pressure, a catheter is inserted into an artery or vein. The invasive pressure setup, consisting of connecting tubing, pressure transducer, an intravenous bag of normal saline all connected together by stopcocks, is attached to the catheter. The transducer is placed level with the heart, and electrically zeroed.

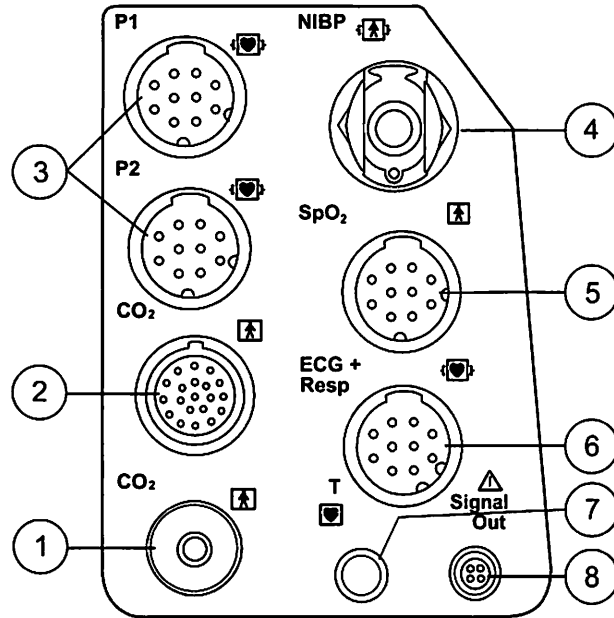
The transducer is a piezo-resistive device that converts the pressure signal to a voltage. The monitor interprets the voltage signal so that pressure data and pressure waveforms can be displayed.

### 1.1.6 Respiration

Impedance respiration is measured across the thorax between three ECG electrodes. The signal of the respiration is made by supplying current between two electrodes and by measuring the differential current from the third electrode. The input current is 200  $\mu$ A (31 kHz). The impedance measured is the impedance change caused by breathing. When the patient is breathing or is ventilated, the volume of the air in the lungs changes, resulting the impedance between the electrodes. From these impedance changes, respiration rate is calculated, and respiration waveform is displayed on the screen.

## 1.2 Main components

### 1.2.1 Side panel



**Figure 2 Side panel connectors**

- (1) -
- (2) Mainstream CO<sub>2</sub> connector
- (3) Connectors for invasive pressure lines
- (4) NIBP hose connector
- (5) Pulse oximetry sensor connector
- (6) ECG trunk cable connector, also used for impedance respiration measurement
- (7) Temperature probe connector
- (8) Signal out connector



### 1.2.2 LM-NIBP board

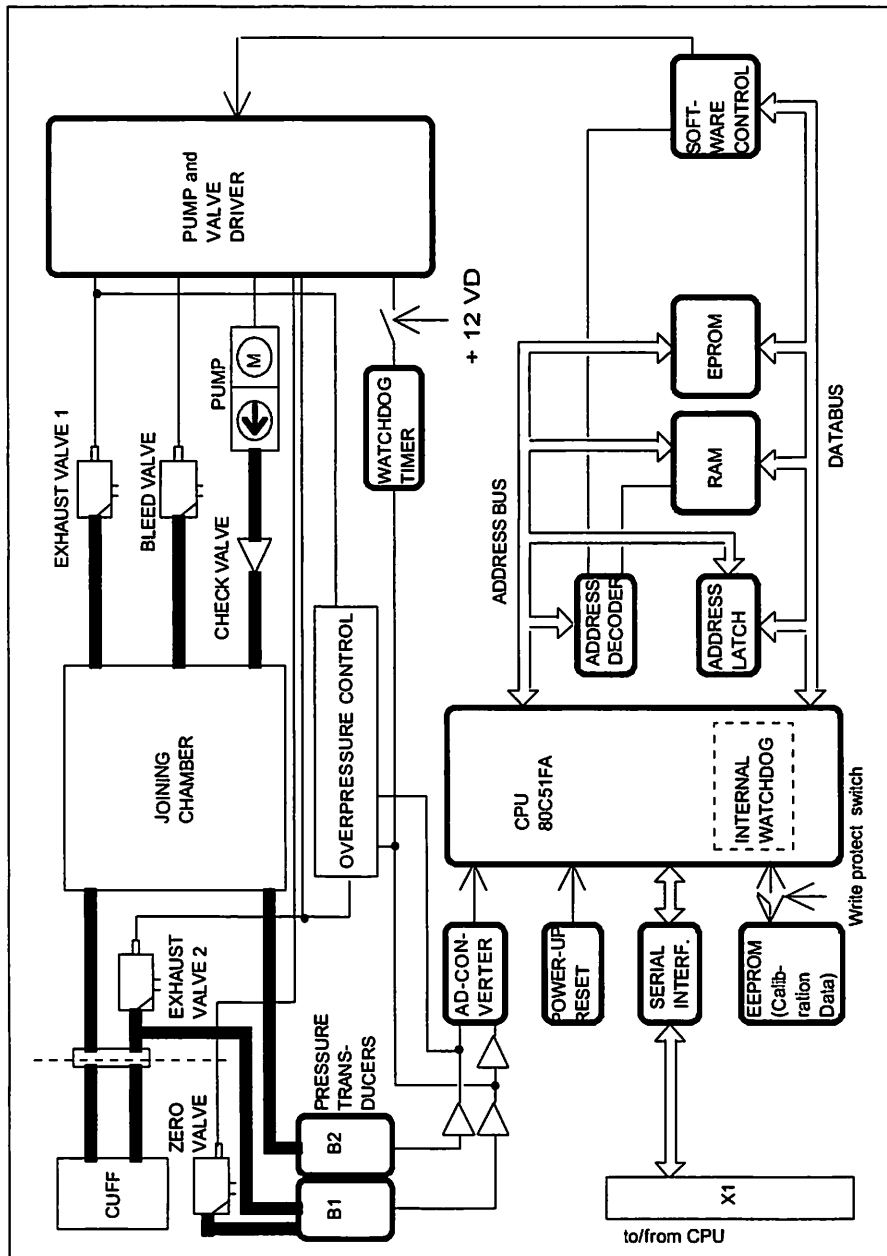


Figure 3 LM-NIBP board functional block diagram

#### Pressure transducers

The NIBP board contains two pressure transducers. They are of piezoresistive type. One is used for measuring the pressure of the blood pressure cuff and the pressure fluctuations caused by arterial wall movement (B1). The other is used for detection of cuff hose type, cuff loose and cuff occlusion situations etc. (B2). The transducers are internally temperature compensated. They are supplied by a constant voltage and their output voltage changes up to 20 mV max. (50 kPa, 375 mmHg).

### Signal processing

Two signals from the pressure transducers are amplified and sent to A/D converter. After the converter, digitized signals are sent to microprocessor for data processing. Before the converter, one of the signals is used to adjust the offset to the pressure safety level.

The NIBP module is controlled with 80C51FA microprocessor at 16 MHz oscillator frequency.

### Memory

NIBP program memory (EPROM) size is  $128k \times 8$ . RAM size is  $32k \times 8$  bit and it stores variable values in NIBP measurement. EEPROM is size  $64 \times 16$  bit and is used to store the calibration values for the pressure transducers, the pulse valve constants gained during measurements, the PC board identification, and module serial number.

### Software control

Software controls valves and pump. In addition to the individual on/off signals for each component there is a common power switch for the valves and the pump that can be used at pump/valve failures.

In addition to external reset line the microprocessor system is equipped with its own power-up reset.

### Watchdog timer

The NIBP module is equipped with software independent safety circuit to disconnect supply voltages from the pump and the valves if the cuff has been pressurized longer than preset time. Pressure limit is specified to 5 mmHg. As soon as the cuff pressure rises over 5 mmHg, timer starts counting. The timer is adjusted to stop the pump and open the valves in 2 minutes 10 seconds in adult/child mode and in 1 minute 5 seconds in infant mode.

## Valves

Exhaust valves are used for emptying the cuff and the joining chamber after the measurement. Exhaust valve 1 is also used as safety valve in infant mode. Valve opens at 165 mmHg. Exhaust valve 2 is also used as safety valve in adult mode and opens at 320 mmHg. Bleed valve is used for emptying the cuff during measurement. Zero valve is used for opening pressure transducer B1 to ambient air.

Safety valve features: When the pressure on B2 exceeds about 315-325 mmHg the exhaust valve V3 opens and drops the pressure for about 10-15 mmHg. This is now only HW dependant valve. In this situation SW cannot control this valve. Electronics between B2 and the transistor that controls the valve is dependant on one instrumentation amplifier and a comparator.

The amplifier and the comparator are dependant on their supply voltage. The supply voltages are watched so that when they go too low, both exhaust valves are opened and the pump will be stopped. If B2 breaks the sw will watch the over pressure with B1. Single case fault does not cause problems and we don't have to care about two case failure.

In the international safety standard IEC 601-2-30 there are no requirements for mechanical safety valve but two independent safety mechanisms for both the over pressure control and timing. The primary control mechanism for pressurization and timing is the sw control. In single fault condition in sw the electronic hw mechanisms limit the pressure and timing. Conformity to the standard is tested by VTT.

## Power supply section

All connections are established via 16-pin connector. The module needs +5 V, and +12 VD power supply to operate. The pump and the valves use +12 VD power line. The supply voltages are generated in the power supply board of the Light Monitor. The reference voltages  $\pm 5 V_{ref}$  are generated on the NIBP board.

### 1.2.3 LM-ECG board

Patient signals are connected to overload protection circuits (resistors and gas-filled surge arresters) and analog switches to instrumentation amplifiers. Then the signals are amplified by 480 and limited by slew rate. Then they are A/D-converted, analyzed and transferred to module bus in digital form.

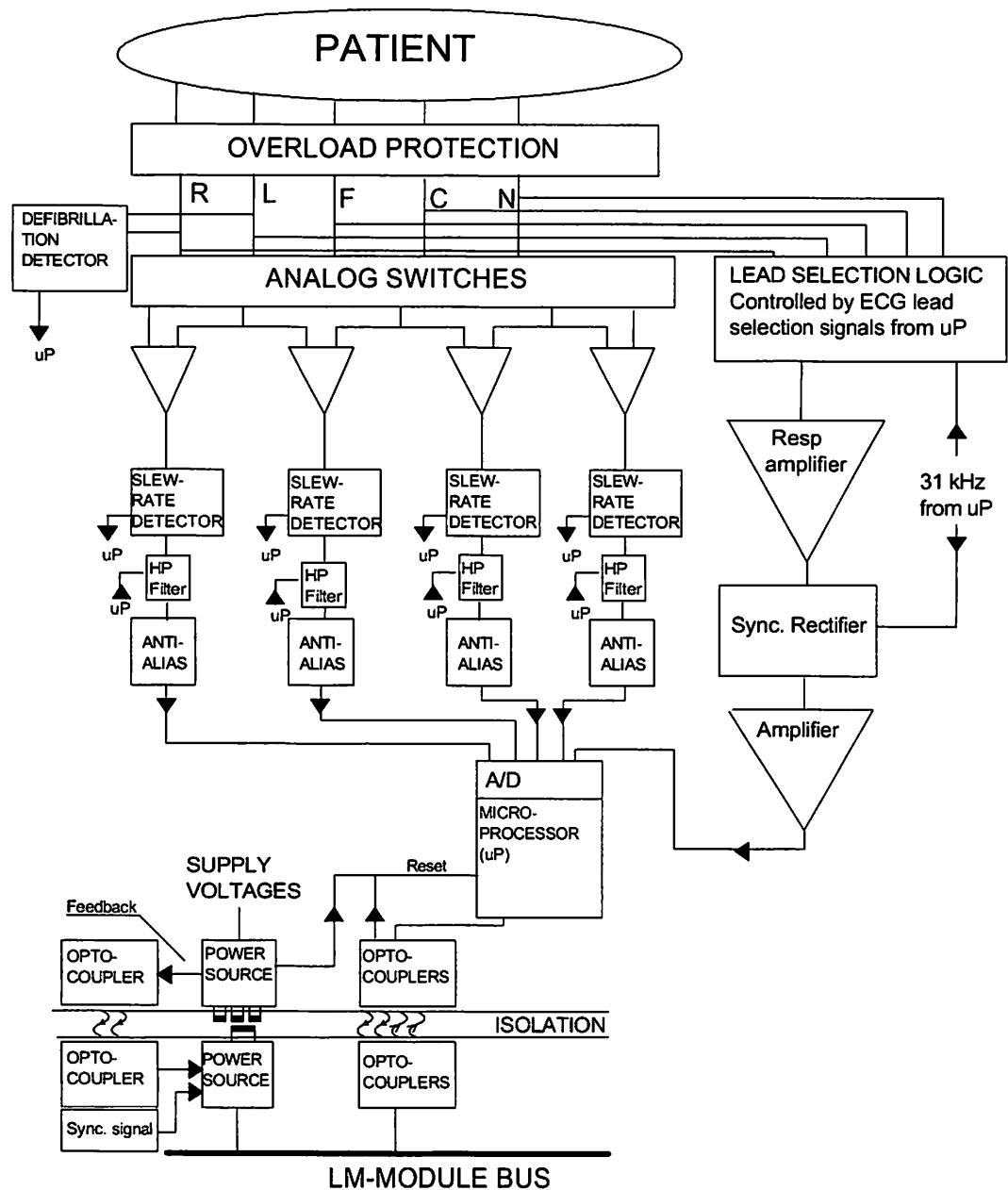


Figure 4 LM-ECG measurement block diagram

#### Analog ECG section

ECG cable is connected to patient connector pins 1 to 5 (ECG signals) on the input board which contains an overload protection circuit.

Leads are connected to amplifiers via analog switches. State of the switches depend on the cable

type.

Noise and pacemaker are detected by a slew rate detector.

Lower frequency is determined by high pass (HP) filter 0.5 Hz (monitor bandwidth).

### ECG filtering

The Light Monitor has two ECG filtering modes:

MONITORING                      0.5 - 30 Hz (-3 dB, with 50 Hz reject filter)  
    0.5 - 40 Hz (-3 dB, with 60 Hz reject filter)

The purpose of filtering is to reduce high frequency noise and low frequency (e.g. respiratory) movement artifacts.

The high-pass filter 0.5 Hz is done with hardware. The monitor sends a command to the LM-ECG board determining the corner frequency 0.5 Hz.

The 50 Hz and 60 Hz reject filters are both low-pass filters with zero at 50 Hz or 60 Hz correspondingly and they are done with software. They are for the mains supply filtering. When these filters are used, -3 dB value for low-pass filter is 30 Hz or 40 Hz.

### Respiration section

ECG electrodes are used to measure impedance change across the thorax. Impedance change is caused by movements and changing air volume in the lungs.

The analog switches control the current supply source of the impedance respiration measurement, and the lead selection for the 3-lead cable can be seen from the following table:

Lead selection	Signal fed between electrodes	Signal measured between electrodes
I	L and R	F* and ground
II	F* and R	L and ground
III	F* and L	R and ground

\*) may be neutral (N) in some older cables

When the 5-lead cable is used, the current source is between L-F and the signal is measured from the N, independently on the lead selection.

The respiration amplifier consist of the operational amplifiers, and the components around them. There is a analog switch for controlling the gain of the first stage of the preamplifier.

Synchronous rectifier consist of the analog switches, which are used for detecting the respiration signal from 31 kHz amplitude modulated raw signal.

The amplifier stage consist of the differential amplifier and the last amplifier. The differential amplifier consist of the operational amplifiers and the components around them. This stage is AC-coupled on both sides for minimising the offset voltages.

The last amplifier is used for amplifying the signal derived from differential amplifier stage.

The respiration signal is zeroed at the beginning of the measurement. Zeroing is also used for fast recovering the measurement after the motion artefact. This is done in amplifier section.

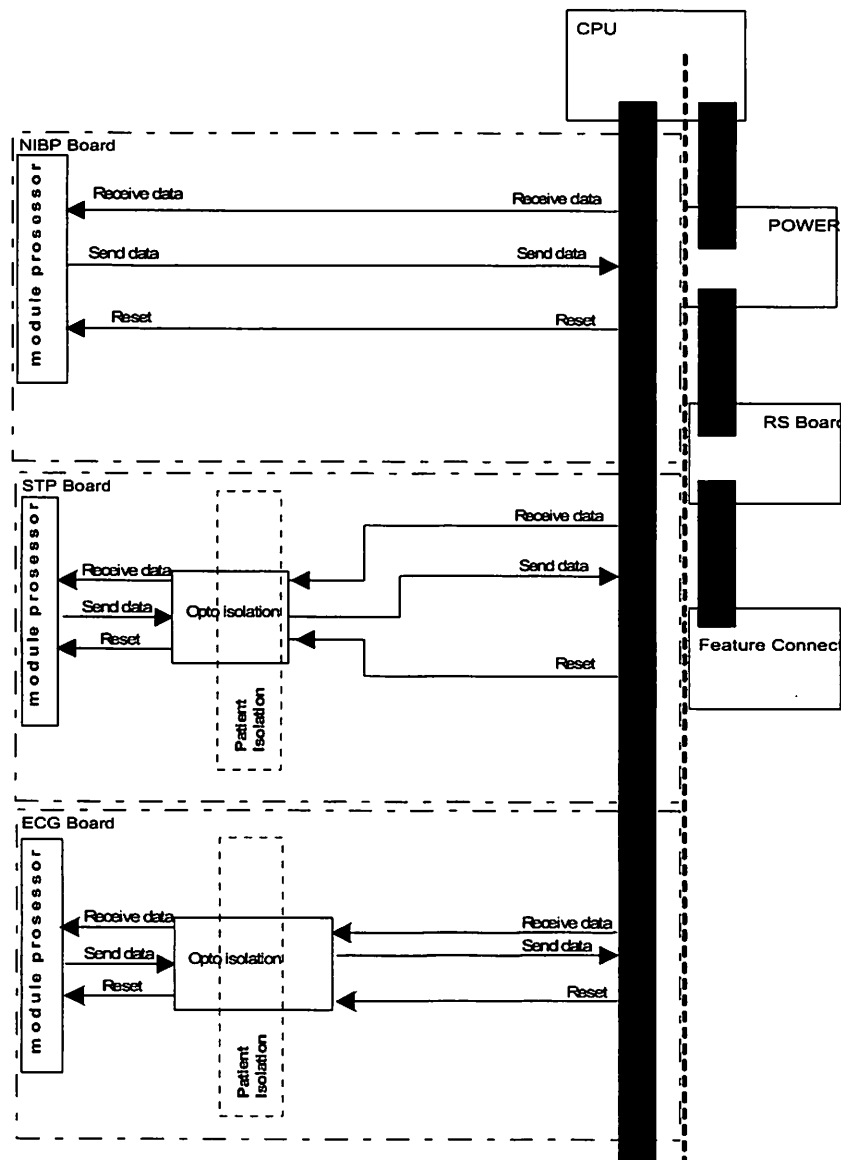
**NOTE:** The respiration measurement is switched "OFF" automatically for 20 seconds when defibrillation is detected at the defibrillation detector.

**Microprocessor section**

Microprocessor contains RAM and EPROM memories. The processor uses external EEPROM memory for storing identifying data. The microprocessor's internal 8-channel A/D-converter converts the ECG-signals to digital form.

**Serial communication**

Communication with the LM module bus is made through RXD and TXD signals. See the principle of serial communication in next figure.



**Figure 5 Serial communication and Opto Isolation**

**Isolated section**

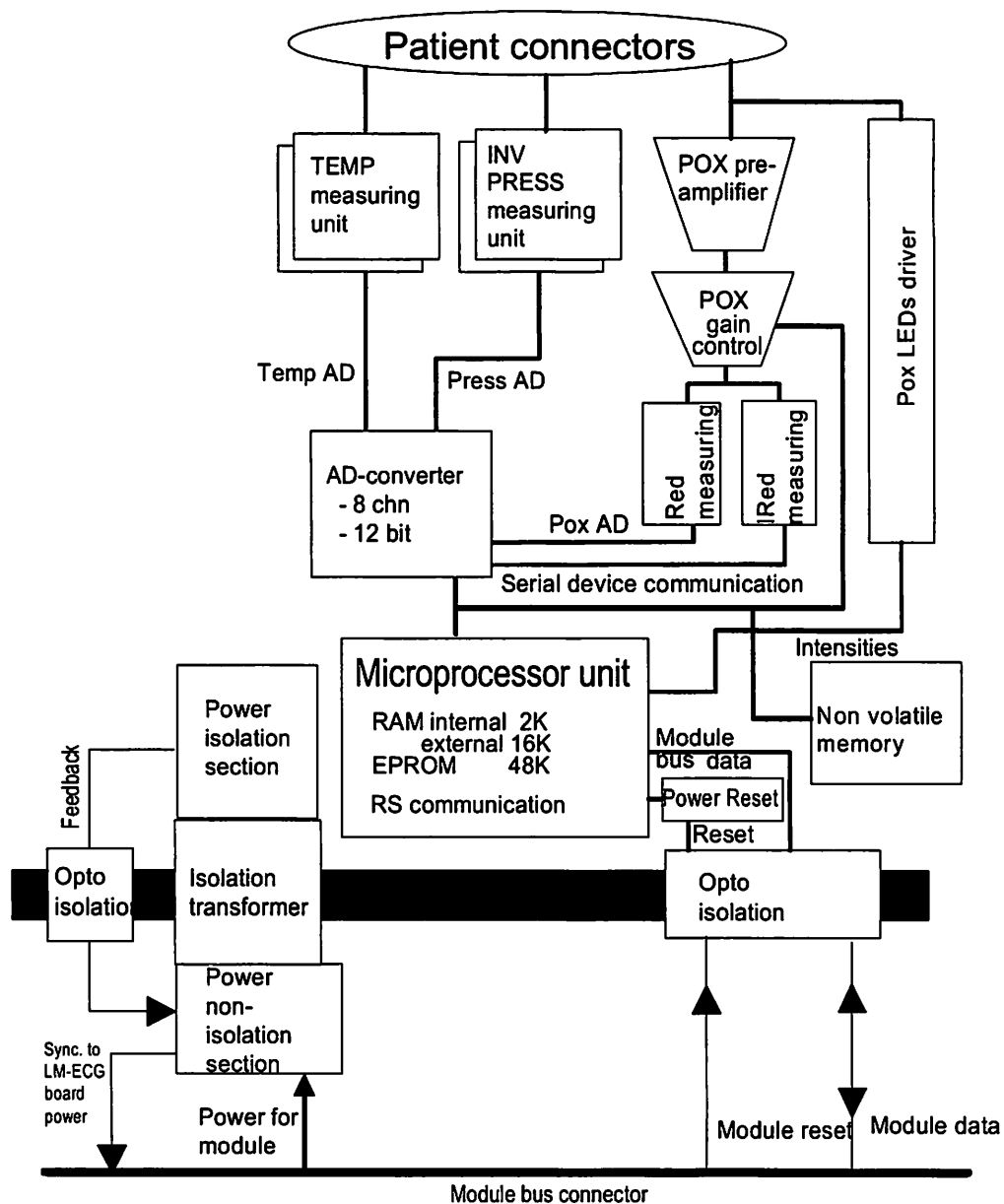
The patient isolation of ECG is 5 kV in ECG board.

**WARNING Do not touch any part of the monitor on patient connections during defibrillation procedure.**

**Power supply section**

See the power supply section in LM-STP board description.  
There is a test connector (X20) on the board for voltages +5 VREF, +5V, +12V, GND and -12V.

**1.2.4 LM-STP board**



**Figure 6 LM-STP board block diagram**

## Microprocessor unit

As processor, Intel's 80C196KC-16 is used. There are external memories, an 8-bit data bus, a 16 MHz oscillator, within the processor there is an open collector reset, and a watchdog timer. Two A/D-converters within the processor are used. The processor's internal UART communicates with the CPU board.

High speed I/O is used to obtain pulse control sequence necessary for pulse oximetry measurement.

## Temperature measurement unit

Value of NTC-resistor in the probe depends on patient's temperature. It is measured with the following principle.

The temperature signal is produced by voltage dividers, part of which is the patient probe (YSI 400-series thermistor). The output is amplified by the calibrated amplifier whose offset voltage makes its output spread on both sides of zero. Wider output range (measurement range) means better resolution.

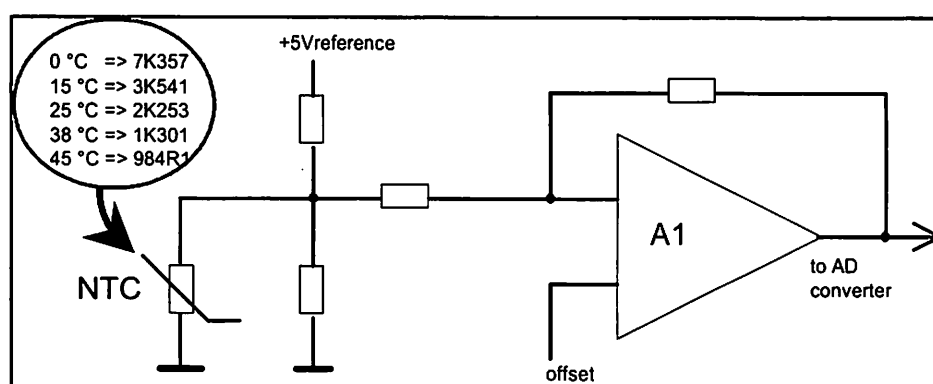


Figure 7 Temperature measurement block diagram

## Invasive blood pressure measurement unit

Isolated and current limited +5 V voltage is supplied to the pressure transducer. From the bridge connection a differential voltage, which depends on pressure and supplied voltage, is calculated (see the formula below).

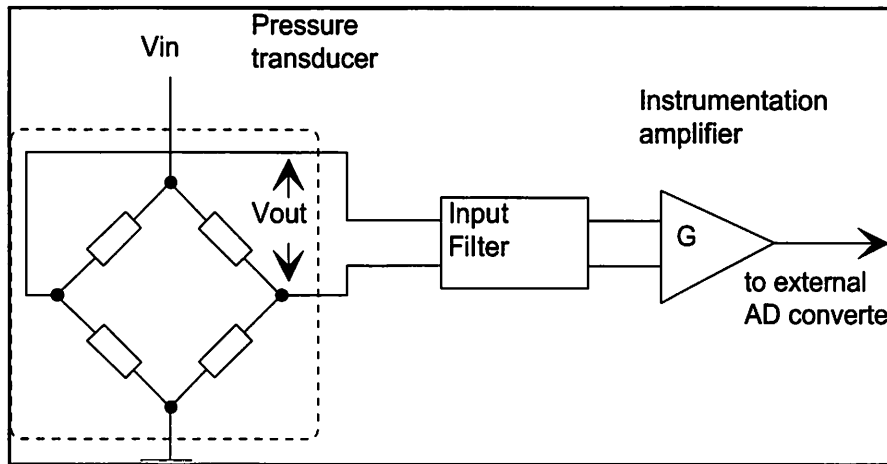
$$U_{out} = U_{ref} \times \text{pressure} \times 5 \text{ } [\mu\text{V}/\text{mmHg}]$$

where  $U_{ref} = 5 \text{ V}$

$$U_{out} = 25 \times \text{pressure} \text{ } [\mu\text{V}/\text{mmHg}]$$

Pressure amplification is realized in the instrumentation amplifier. Gain of the amplifier is set so that the level of the signal transferred to A/D converter stays within the measurement range even when there are circumstantial offsets or offsets caused by the transducer. There is a filter before the amplifier to attenuate high frequency disturbances.





**Figure 8 Pressure transducer working principle**

### **Pulse oximetry measurement section**

#### **LED control signals**

The processor sends pulse width modulated signals, IRED intensity and RED intensity, which are converted to DC voltage and filtered. By switches either RED or IRED intensity is sent forward to amplifier in LED driving circuit.

#### **LED driving circuit**

Voltage difference which corresponds to LED current, is measured by the differential amplifier circuit and its output is sent back to the processor in 0 to 5 V level. There are feedback circuits from LED current measurement and LED intensity control.

#### **Measured signal preamplification**

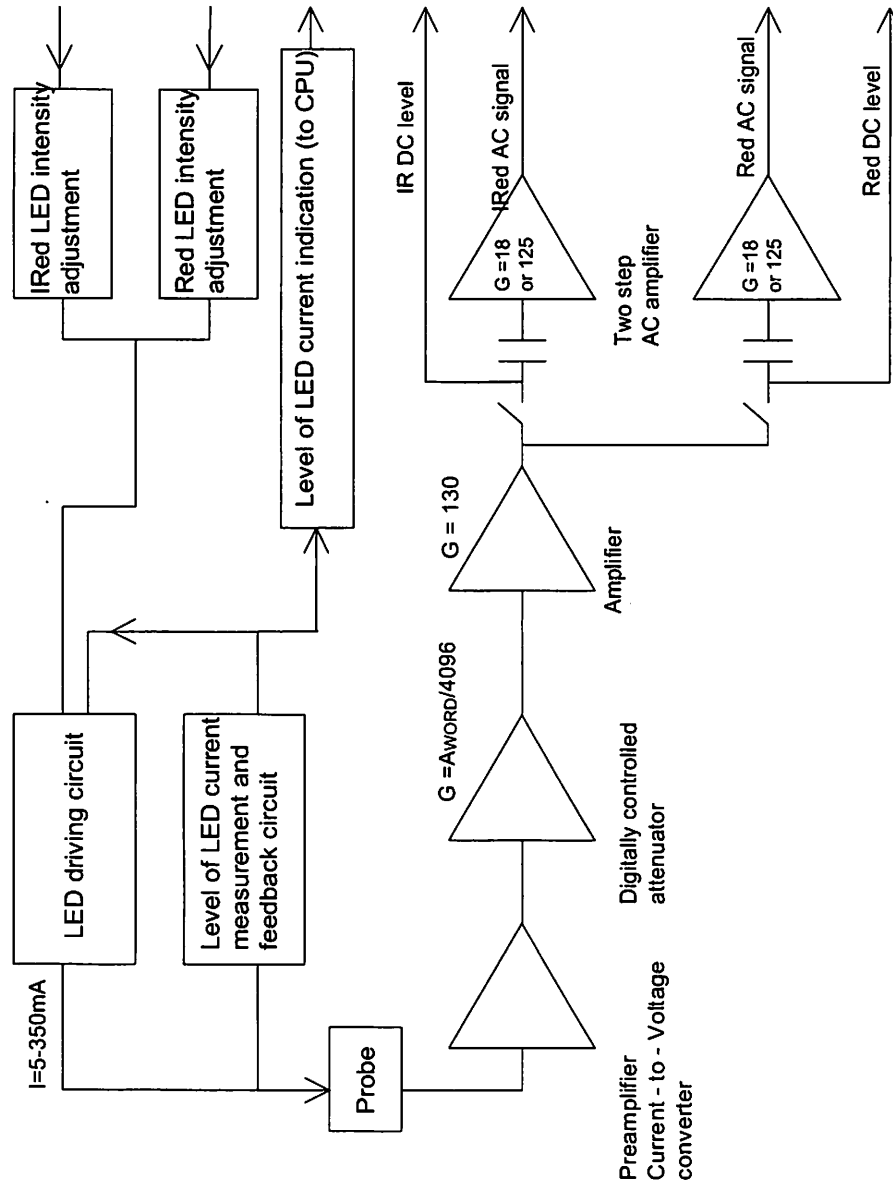
Preamplifier is current-to-voltage converter with gain selection.

#### **Digitally controlled amplifier**

D/A converter is a part of digitally controlled amplifier after which there is another constant amplifier.

**Red and infrared channel separation**

Red and infrared channels are separated from each other by switches. Operational amplifier functions as a buffer and after this infrared and red DC signals are sent to the processor. A capacitor separates AC signal from DC signals and the AC signals are sent to the processor after amplification. There is a switch to choose the amplification constant.



**Figure 9 Pulse oximetry measurement block diagram**

## **Isolated section**

### **Signal isolation**

There are two opto isolators to isolate serial communication between LM-STP and CPU board. Reset line is an open collector type with a pull-up resistor. With that signal the processor is able to use its internal watch-dog function. CPU board can reset LM-STP board processor. On the isolated section there is a supply voltage monitor connected to the reset signal.

### **Power supply section**

Both LM-ECG and LM-STP boards have the same kind of switching mode power supply. Note that generated isolated voltages are different in LM-STP and LM-ECG board. Both power supplies uses an same oscillator, which is located on the LM-STP board. The synchronization signal is transferred to the LM-ECG board via a module bus cable.

The core of the power supply is a PWM controller which controls a FET transistor. The transistor supply the power to a special pulse transformer. The controller uses a feedback signal from the analog optocoupler to stabilize isolated +5 V voltage. All other voltages, except +5 V for microprocessor section, are stabilized with linear regulators.

## 1.3 Connectors and signals


### 1.3.1 Module bus connectors

Pin CPU/NIBP/ECG	Pin STP	I/O <sup>1)</sup>	Signal	Description
1	16	-	P12VD	+ 12 V module voltage
2	15	-	P12VD	+ 12 V module voltage
3	14	-	GND	Ground
4	13	-	-	-
5	12	-	-	-
6	11	-	-	-
7	10	-	GND	Ground
8	9	-	ESTPCLK	ECG/STP power clock
9	8	-	GND	Ground
10	7	-	P5VD	+ 5 V module voltage
11	6	O	TXDM	Data to modules
12	5	I	RXDM	Data from modules
13	4	O	RSTM#	Module Reset
14	3	-	GND	Ground
15	2	I	WTP#	Water trap present
16	1	-	GND	Ground

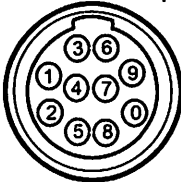
<sup>1)</sup> Signals according to CPU board

### 1.3.2 Patient panel connectors

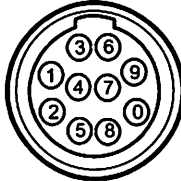
#### ECG connector (ECG)

BLUE	Pin No	Signal
	1	Right arm electrode (R)
	2	Left arm electrode (L)
	3	Right leg electrode (RL)
	4	Left leg electrode (F)
	5	Chest electrode (C)
	6	Cable shield
	7	Not connected
	8	3/5 lead identification
	9	Lead connection check
	0	Ground

#### SpO<sub>2</sub> connector (SpO<sub>2</sub>)

GREY	Pin No	Signal
	1	Feedback resistor
	2	Not connected
	3	Ground
	4	Sensor identification
	5	Sensor identification ground and cable shield
	6	LED drive ground
	7	LED drive current
	8	Input signal current
	9	Signal ground
	0	Not connected

#### Invasive blood pressure connectors (P1, P2)

RED	Pin No	Signal
	1	Pressure -
	2	Pressure +
	3	Polarisation - (ground)
	4	Polarisation +
	5	Not connected
	6	Not connected
	7	Not connected
	8	Not connected
	9	Ground
	0	Cable detection

### 1.3.3 Test points

#### LM-ECG and LM-STP board

There are voltage test pins both on LM-STP and LM-ECG boards. Pins and voltages are as follows:

##### LM-ECG

X20	pin 1	+5 V
	pin 2	+5 Vref
	pin 3	+12 V
	pin 4	Gnd
	pin 5	-12 V
	pin 6	not connected
	pin 7	Receive/Send

##### LM-STP

X11	pin 1	+5 V test
	pin 2	+5 Vref
	pin 3	+7 V
	pin 4	Gnd
	pin 5	-7 V
	pin 6	-5 V
	pin 7	Send/Receive

## 2 SERVICE PROCEDURES

### 2.1 General service information

Field service of the printed circuit boards is limited to replacing the faulty printed circuit boards or mechanical parts. The printed circuit boards should be returned to Datex-Ohmeda for repair.

Datex-Ohmeda is always available for service advice. Please provide the unit serial number, full type designation, and a detailed fault description.

**CAUTION** Only trained personnel with appropriate equipment should perform the tests and repairs outlined in this section. Unauthorized service may void warranty of the unit.

### 2.2 Service check

#### Conventions used in this section

Names of the keys are written in bold Helvetica typeface, for example **Normal Screen**.

Selectable menu items are written in bold and italic typeface, for example ***Previous Menu***.

Informative messages displayed on the screen are written in normal typeface, but separated with quotation mark, for example 'Please wait'.



means that the procedure should be signed in the check list.

#### Tools needed

- Light Monitor
- Patient simulator (for example Dynatech Nevada MedSim 300 Patient Simulator)
- Pressure manometer, range up to 330 mmHg
- Temperature test set (order code 884515)
- 3-lead and 5-lead ECG cable
- SpO<sub>2</sub> finger sensor
- InvBP transducer
- Adult NIBP cuff & hose
- Infant NIBP cuff & hose
- Screwdriver (phillips type)

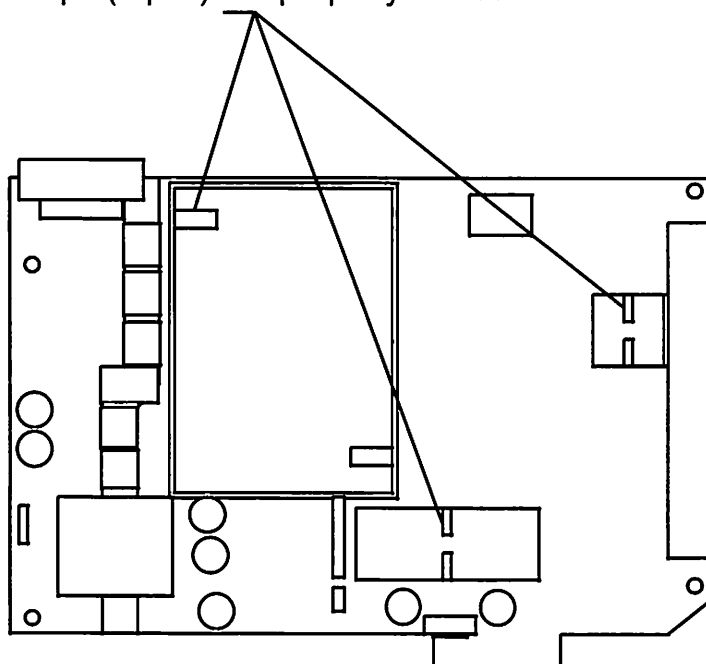
**Parts needed**

- NIBP pump filter (order code 57141)

Preventive maintenance is recommended to be performed according to the following instructions at least once a year and always after service or repair.

1. Check internal parts:
  - screws are tightened properly
  - cables are connected properly
  - EMC covers are attached properly

Check that all shielding flaps (6 pcs) are properly closed



**Figure 10** LM-STP board EMC covers



2. Check external parts:
  - the patient panel sticker is intact
  - all connectors are intact and are attached properly
  - both screws on the patient panel are tightened properly





3. Replace the NIBP pump filter (p/n 57141).



- Switch the monitor on and wait until the monitoring screen appears. Configure the monitor screen so that all the needed parameters are shown, for example as follows:

**Menu - Setup Monitor**

**Waveform Fields**

Field 1 ⇨ ECG  
Field 2 ⇨ P1  
Field 3 ⇨ P2  
Field 4 ⇨ Resp  
Previous Menu

**Digit Fields**

Lower Field 1 ⇨ NIBP  
Lower Field 2 ⇨ Temp

4. Connect the simulator and check that all needed parameter information is showed on the screen.



- Preset ECG, Respiration, InvBP and SpO<sub>2</sub> measurement settings:

**Menu - ECG & Resp**

**ECG Setup**

HR Source ⇨ AUTO  
Pacemaker ⇨ Show  
Previous Menu

**Resp Setup**

Size ⇨ 1.0  
Resp Rate Source ⇨ AUTO  
Measurement ⇨ ON  
Detection limit ⇨ AUTO  
Previous Menu

**NIBP & Inv. Press - P1 Setup&Alarm**

Label ⇨ Art  
Previous Menu

**P2 Setup&Alarm**

Label ⇨ CVP

**Menu - SpO<sub>2</sub> & Temp**

Pleth Scale ⇨ AUTO

---

## ECG measurement

5. Enter the main menu:

**Menu - Monitor Setup - Install/Service** (password 16-4-34) - **Service View**  
(password 26-23-8)

Take down the information regarding ECG, STP, and NIBP board software (SW) by selecting **Scroll Vers** and turning the ComWheel or choose **Records Vers** if the recorder is installed.



6. Enter the ESTP : ECG service menu:

**Menu - Monitor Setup - Install/Service** (password 16-4-34) - **Service View**  
(password 26-23-8) - **Modules - ESTP : ECG**

Check that the "Timeouts", "Bad checksums" and "Bad c-s by mod" values are not increasing faster than by 50 per second. Check also that the ECG board memories have passed the internal memory test, i.e. the "RAM", "ROM" and "EEPROM" state all OK.



7. Check that the power frequency value has been set according to the current mains power frequency. Change the setting by selecting **Power Freq**, if necessary.



8. In the ECG Setup Menu: Connect a 5-lead ECG cable to the monitor. Check that the "Cable type" shows **5elect** in the ECG Setup menu. If it shows **3elect**, make sure the used 5-lead ECG cable contains the necessary wiring for cable recognition (pins 0, 8 and 9 connected together).



9. In the ECG Module Menu: Check that all the electrodes show OFF in the service data field and the message "Leads Off" is shown on the screen.

Connect all the leads together, for example to a suitable screwdriver. Check that all the electrodes show ON and the message "Asystole" appears.

Disconnect one of the leads and check that the corresponding electrode in the service menu shows OFF within 10 seconds from the disconnection, then reconnect the lead. Check the rest of the leads using the same method.

**NOTE:** When the ground lead (RL, right leg) is disconnected all the electrodes should show OFF.



10. Connect a 3-lead cable to the monitor.

Connect the leads together (e.g. to a screwdriver).

Select one lead (I, II or III) for display.

Detach a lead from the screw driver, and see that the monitor responds as described in the table below. Connect the lead again and check that "Leads off" message disappears.

Lead selection	Lead to be detached	Message
Lead I	L/LA R/RA N/LL	Leads off Leads off Leads off
Lead II	L/LA R/RA N/LL	Leads off Leads off Leads off
Lead III	L/LA R/RA N/LL	Leads off Leads off Leads off

Check that in any case the correspondence electrode (RA, LA or LL) shows off. Electrodes V and RL shows off all the time. In cases I and N, II and R, III and L all electrodes shows off.

11. Connect the leads to a patient simulator.

The settings and checks with Dynatech Nevada MedSim 300 Patient Simulator:

ECG - BASE - BPM  $\Rightarrow$  160

ECG - PACE - WAVE  $\Rightarrow$  NSR

Check that normal ECG waveform is shown, the HR -value is 160 ( $\pm$ 5) and the "Pacer count" -value is not increasing in the service menu. Check the lead selections by pressing the ECG LEAD -key on the module (not available in NESTRP -type modules).

ECG - PACE - WAVE  $\Rightarrow$  ASNC

Check that pacemaker markers are shown on the ECG waveform, the HR -value changes to 75 ( $\pm$ 5) and the "Pacer count" -value is increasing according to shown pacemaker markers.

Set the pacemaker option off:

ECG - PACE - WAVE  $\Rightarrow$  NSR



## Respiration measurement

12. Check that the "Resp Available" and "RESP Measurement" show both ON in the ESTP:ECG service menu.



Do the following settings:

**Menu - ECG & Resp - ECG Lead  $\Rightarrow$  II**

and use 3-lead ECG cable.

13. Check the respiration measurement with a patient simulator.

The settings and checks with Dynatech Nevada MedSim 300 Patient Simulator:

BASELINE IMPEDANCE -switch  $\Rightarrow$  500

LEAD SELECT-switch  $\Rightarrow$  II/RL-LL

RESP

WAVE  $\Rightarrow$  NORM

RATE  $\Rightarrow$  20

OHMS  $\Rightarrow$  1.0

RATIO  $\Rightarrow$  1/1

APNEA  $\Rightarrow$  OFF

SHIFT  $\Rightarrow$  OFF

Check that the RESP waveform is shown and the RR -value is 20 ( $\pm$ 5). Change the position of the BASELINE IMPEDANCE -switch and check that appropriate RESP waveform and RR -value are shown again within 30 seconds.

**NOTE:** If no RR-value appears check that the lead marked as N or F is connected to the connector marked as LL on the simulator.

RESP - APNEA  $\Rightarrow$  32 S

Check that the monitor gives the APNEA -alarm.

**NOTE:** Make sure that only the ECG leads are connected to the simulator during the apnea -test. If other cables are connected at the same time, the respiration signal from the simulator may be disturbed, and therefore, the APNEA -alarm may not be activated.



## Temperature measurement

Configure the monitor waveform field 4 so that it shows pleth waveform:

**Menu - Monitor Setup - Waveform Fields - Field 4 ⇨ Pleth**

14. Enter the ESTP : STP module menu:

**Menu - Monitor Setup - Install/Service (password 16-4-34) - Service View (password 26-23-8) - Modules - ESTP : STP**

Check that the "Timeouts", "Bad checksums" and "Bad c-s by mod" values are not increasing faster than by 50 per second. Check also that the STP board memories have passed the internal memory test, i.e. the "RAM", "ROM" and "EEPROM" show all OK.



15. Check that the "Cable" and "Probe" show OFF for channel T1, when no sensor is connected.

Connect a temperature test plug into the connector TEMP. Check that the "Cable" and "Probe" for T1 show ON and the temperature value appears on the monitor screen.



16. Check the temperature calibrations using temperature test plugs. If the deviation on a temperature reading on the screen is more than 0.1 °C, calibrate the temperature channels according to the instructions in the Technical Reference Manual.



17. Activate the temperature test by selecting TEMP TEST from the menu and pressing the ComWheel twice. When the message "Performing temp test" disappears from the digit field, check that no error messages appear and "Temp error" shows OFF for T1 in the service menu.



## For F-LMP1 with the invasive blood pressure measurement

18. In the ESTP Module menu: Check that the "Cable" and "Probe" for P1 show OFF in the Service Data field. Plug a cable with an invasive blood pressure transducer into the front panel connector P1 and check that the "Cable" and "Probe" show ON and the corresponding pressure waveform appears onto the screen.

Perform the same check also for the InvBP channel P2.



19. Calibrate the InvBP channels P1 and P2 according to the instructions in the Technical Reference Manual.



20. Check the InvBP channels with a patient simulator.

The settings and checks with Dynatech Nevada MedSim 300 Patient Simulator:

SENSITIVITY -switch  $\Rightarrow$  5  $\mu$ V/V/mmHg

ECG - BASE - BMP  $\Rightarrow$  60

BP - 1 - WAVE  $\Rightarrow$  ATM

BP - 2 - WAVE  $\Rightarrow$  ATM

Restore the normal monitoring screen by pressing the key **Normal Screen**.

Connect cables from the channels BP1 and BP2 to the module connectors P1 and P2. Zero the InvBP channels by pressing the key ZERO ALL on the monitor front panel.

BP - 1 - WAVE  $\Rightarrow$  ART

BP - 2 - WAVE  $\Rightarrow$  CVP

Check that appropriate InvBP waveforms are shown and the InvBP values are approximately 120/80 ( $\pm$ 3 mmHg) for the channel P1 and 15/10 ( $\pm$ 2 mmHg) for the channel P2.

Check that HR- value is calculated from P1 when ECG is not measured (ECG cable disconnected).



## SpO<sub>2</sub> measurement

21. Check that the message "No probe" is shown when no SpO<sub>2</sub> sensor is connected to the module. Connect a SpO<sub>2</sub> finger sensor to the module. Check that the message "Probe off" is shown when the sensor is not connected to a finger.



22. Connect the SpO<sub>2</sub> sensor onto your finger. Check that the reading of 95-99 and the typical SpO<sub>2</sub> waveform appears. Check that HR -value is calculated from SpO<sub>2</sub> when ECG and InvBP (P1) are not measured.

Disconnect the SpO<sub>2</sub> sensor and check that "Probe off" message appears.



## Non invasive blood pressure measurement

23. Enter the NIBP module service menu:

**Menu - Monitor Setup - Install/Service** (password 16-4-34) - **Service View**  
(password 26-23-8) – **Modules - NIBP**

Check that the "Timeouts", "Bad checksums" and "Bad c-s by mod" values are not increasing faster than by 50 per second. Check also that the NIBP board memories have passed the internal memory test, i.e. the "RAM", "ROM" and "EEPROM" show all OK.



24. Check the pump and valves.

Highlight **Pneumatics** from the NIBP menu and press the ComWheel. Connect a pressure manometer to the NIBP module cuff connector.

Select **Start Pump** and press the ComWheel. Check that the pump turns on and the pressure inside the tubing system starts to increase. Stop the pump by pressing the ComWheel again when the pressure reaches 280 mmHg.

Highlight **Open Exh1**. Press the ComWheel and check that the pressure inside the tubing system starts to drop then press the ComWheel again. Check the other exhaust valve by the same way by selecting **Open Exh2** from the menu.

If necessary, turn the pump on again for a moment to increase the pressure inside the tubing system.

Highlight **Set Valve**. Press the ComWheel and set the value under the text "Pulse Valve" to number 120 by turning the ComWheel. Press the ComWheel again and check that the pressure inside the tubing system starts to drop. Finish the test by selecting **Previous Menu**.



25. Check the NIBP tubing system for leakages.

Select **Calibrations** from the NIBP service menu.

Connect the pressure manometer to the NIBP module cuff connector. Start the active leak test from the menu by pressing the ComWheel. The module pumps a pressure of about 265 mmHg and then the pump stops.

Wait for 15 seconds for the pressure to stabilize then check that the pressure does not drop more than 6 mmHg per one minute. Release the pressure by pressing the ComWheel once more.



---

26. Calibration check.

Recalibrate the NIBP measurement. Remember to set the calibration protection back on after the calibration.

Disconnect the pressure manometer. Select **Calibrations** and then highlight **Calibration Check**. Press the ComWheel and take down the zero offset values for both pressure transducers, B1 and B2. The values should be within  $\pm 10$  mmHg.

Connect the pressure manometer to the cuff connector and check the calibration with pressures 100 mmHg, 200 mmHg and 260 mmHg. The zero offset value must be added to the displayed pressure value in order to determine the real pressure.



27. Checking the watchdog timer activation pressure.

Check from the service view (modules -> NIBP) that  $ADO=0 \pm 1$ , when there is no pressure in cuff. If it is not; see instructions from section 3.3.

Select **Pneumatics** from the NIBP module menu.

Keep the pressure manometer connected to the cuff connector. Pump up the pressure very slowly and note the value on the manometer when you hear a signal from the loudspeaker. The pressure at where the watchdog timer should activate with an audible signal is 11 mmHg (11...15 mmHg).



28. Checking the watchdog timer.

Select **Watchdog** from the NIBP module menu.

Check the watchdog timer in the adult mode. Activate the timer by highlighting **Test ADULT** and then pressing the ComWheel. Check that the time beside the text "Watchdog Interval" starts to run. Wait until you hear a signal from the loudspeaker and then check the time again. The time from the adult test should fall within 120-140 seconds (counter stops + beep).



Check the watchdog timer also in the infant mode by first selecting **Test INFANT** from the menu. The time from the infant test should fall within 60-70 seconds (counter stops + beep).



29. Checking the safety valve feature.

Select **Safety Valve** from the NIBP module menu.  
Keep the pressure manometer connected to the cuff connector.

**NOTE:** Make sure your pressure manometer can be used to measure pressures over 300 mmHg. If such a pressure manometer is not available, perform the check with an adult cuff that is connected around some round object, for example a calibration gas bottle.

Start the safety valve test by pressing the ComWheel and wait until the pump stops and the pressure is deflated. Check the pressure value at where the safety valve opened from beside the text "Max press". The value should be 305 mmHg ( $\pm 15$  mmHg) for both transducers.

Check also what was the pressure inside the NIBP tubing system at 2 seconds after the pump stopped. The values beside the text "2 s after stop" should be higher than 280 mmHg. If either of the values is less, check the NIBP tubing system for leakages.

Return to the normal monitoring mode by pressing **Normal Screen**.



30. Connect an adult NIBP cuff to the cuff connector and disconnect one of its hoses.

Start NIBP measurement by choosing the **Start Cycling** and check that the message "Cuff loose" appears on the screen within 30 seconds.

Reconnect the hose and then bend it with your fingers. Restart the measurement and check that the message "Cuff occlusion" appears on the screen within 30 seconds.



Check that automatic inflation limits are in use:

**Menu - NIBP & Inv. Press - NIBP Setup&Alarm - Inflation Limits  $\Rightarrow$  AUTO**

Previous Menu

31. Connect the cuff onto your arm, highlight **Start Ven.Stasis** in the NIBP & Inv. Press menu and press the ComWheel. Check the measurement identifies the cuff, i.e. the text "Adult" appears into the NIBP digit field for a short moment.

Keep the pressure inside the cuff for about half a minute in order to see that the cuff is not leaking, then press the ComWheel again. Select **Normal Screen**.



32. Keep the cuff on your arm and perform one NIBP measurement. Check that the measurement gives a reasonable measuring result.



33. Connect an infant cuff to cuff connector and wrap it around your fingers. Start NIBP measurement and check that the measurement identifies the cuff, i.e. the text "Infant" appears into the NIBP digit field. **Cancel** the measurement after the cuff identification.



### For Light Monitor

34. Perform electrical safety check and leakage current test.



35. Check that the monitor functions normally after the performed electrical safety check.



36. Clean the monitor with suitable detergent.



- Fill in all necessary documents.

## 2.3 Adjustments and calibrations

### NIBP

#### Pressure safety level detection "OFFSET"

Check from the service view (Modules -> NIBP) that  $ADO = 0 \pm 1$ . If it is not: remove the back panel and adjust the trimmer located NIBP boards upper edge ADO to zero. Pump up the pressure very slowly and check that the value of AD5 changes from negative value to positive value under pressure 11...15 mmHg.

#### NIBP calibrations

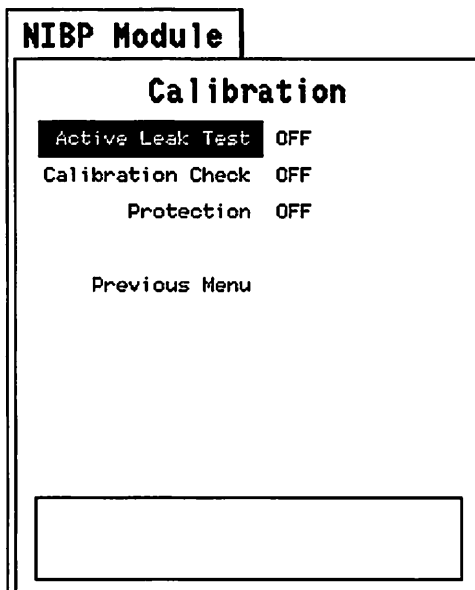
The electronics of NIBP pressure measurement is calibrated at the factory. Zeroing pressure is automatically maintained by the processor. If the zero point of the pressure transducer drifts more than specified, an error message is given and the NIBP board should be recalibrated or replaced.

The calibration can be checked and recalibrated in the NIBP service menu.

The calibration of the primary pressure channel can also be checked from the NIBP setup menu (NIBP, NIBP Setup, Calibration Check). In this case the auto zeroing is performed at start - remove hose before entering to ensure atmospheric pressure to the pressure transducers - the primary pressure is displayed. The zero-offset value should then be zero.

#### Calibration check

1. Enter Calibration menu.



2. Select "Calibration Check" and press the ComWheel.
3. Connect an external precision manometer to the module.
4. Pump the following pressures to manometer and check the difference between the manometer and monitor pressure display:

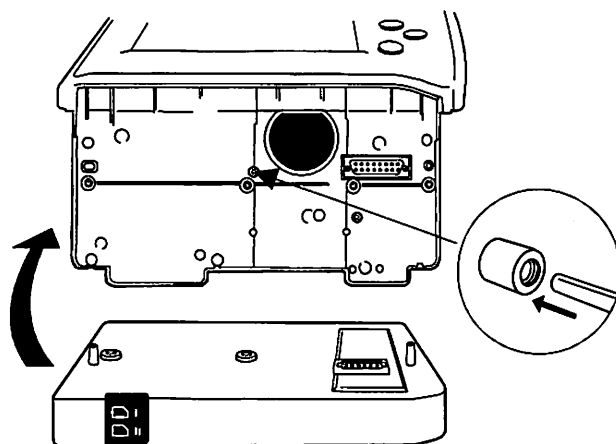
Pressure	Max. error	Example
0 mmHg	$\pm 9$ mmHg (=zero offset)	-2
100 mmHg	100 + zero offset $\pm 2$ mmHg	98 $\pm 2$
200 mmHg	200 + zero offset $\pm 3$ mmHg	198 $\pm 2$

If the error of pressure channel B1 is larger than specified above, the module should be recalibrated. The error of B2 is allowed to be even twice as large because it has no effect on blood pressure measurement accuracy. However, it is recommended to recalibrate the module also when the error of B2 is larger than specified above to ensure best possible operation.

### Calibration

1. Enter Calibration menu.
2. Remove hoses from front panel connector to enable proper zeroing.
3. Select "Calibration". If it is not available, perform the steps A,B, and C.

**NOTE:** If there is the battery module in the monitor do remove it before calibration.



- A) Push the switch at the bottom of the device to enable the calibration. This enables menu selection "Protection". The message "Calibration switch ON!" appears.
  - B) Select Protection OFF in the Calibration menu and push the ComWheel while pressing the calibration switch.
  - C) Release the switch. Menuselection "Calibration" is now enabled, and "Protection" is disabled. When the calibration is enabled, a message "Calibration not protected" appears.
4. Start Calibration by pushing the ComWheel. Messages "ZEROING" and "ZEROED" will appear in the NIBP message field. After this a pressure bar will appear.
  5. Connect an external mercury manometer with pump to device through the both tubes of the hose - both transducers B1 and B2 must be calibrated simultaneously. Pump up to a

pressure about 200 mmHg according to the manometer. Calibration is possible in the range 150 to 300 mmHg.

6. Verify that both pressure values in the prompt field match the manometer reading. If not, adjust by turning the ComWheel. When the values of the pressure bar and the manometer are equal, press the ComWheel to confirm the calibration. The message "Calibrating" will appear onto the NIBP digit field. After a few seconds it is followed by "Calibrated", which means that the calibration has succeeded, and the new calibration data has been saved into EEPROM.

To set the protection on:

Push the calibration switch to the bottom and keep it at the bottom. Select "Protection ON", push the ComWheel and release the switch.

7. Switch off the monitor and then turn it on. Then perform Calibration Check (see the preceding page) to verify the new calibration.

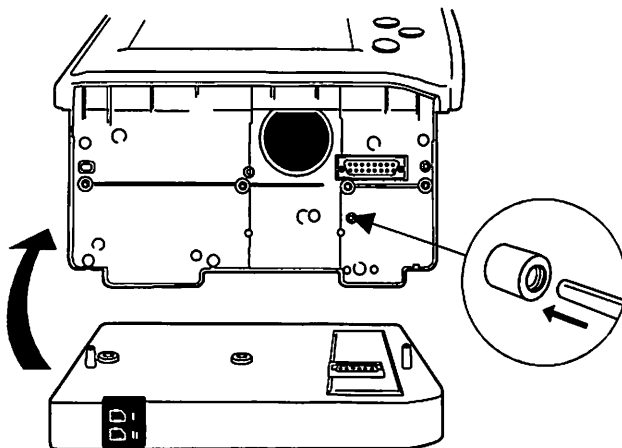
## Temperature calibration

**NOTE:** For the temperature calibration, separate, accurate test plugs (25 °C and 45 °C) are needed.

A test set of two plugs is available from Datex-Ohmeda, order code 884515.

Calibrate temperature when measured test values deviate more than  $\pm 0.1$  °C, and always after LM-STP board replacement.

1. Enter ESTP: STP service menu.  
(**Main Menu - Monitor Setup - Install/Service** (password 16-4-34) - **Service View** (password 26-23-8) - **Modules**).
2. Enter Calibrations menu.
3. Press the protect button at the bottom of the monitor and choose OFF in protect mode. Release the button.



4. Choose Calibrate T1 in the service view.
5. Insert calibration plug (25 °C) into Temp connector.
6. Push the ComWheel two times.

7. Insert calibration plug (45 °C) into Temp connector.
8. Push the ComWheel two times.
9. Press in the protect button at the bottom of the module and choose ON in protect mode. Release the button.

### **Invasive pressure calibration**

Calibrate invasive pressure when the pressure transducer (probe) is replaced with a different type of transducer, and when LM-STP board is replaced.

1. Enter ESTP: the STP service menu.  
**(Main Menu - Monitor Setup - Install/Service - Service View - Modules).**
2. Enter Calibrations menu.
3. Connect a pressure transducer with a pressure manometer to the P1/P2 connector. Choose Calibrate P1 or Calibrate P2. Leave the transducer to room air pressure.
4. Push the ComWheel to start zeroing.
5. Supply a pressure of 100 mmHg to 300 mmHg to the transducer. The recommended pressure is 200 mmHg.
6. Set the pressure on the display to match the pressure reading on the manometer and push the ComWheel. A tolerance of  $\pm 1$  mmHg is allowed.
7. The text "Calibrated" will appear on the display.

### 3 TROUBLESHOOTING

#### 3.1 Troubleshooting charts

See also the User's Reference Manual for more troubleshooting procedures.

#### NIBP

TROUBLE	CAUSE	TREATMENT
No NIBP value displayed	NIBP not selected on screen.	Check monitor setup.
Artifacts-message	Unsuccessful measurement due to patient movements or shivering.	
Weak pulsation-message	Weak or unstable oscillation pulses due to: <ul style="list-style-type: none"> <li>• Artifacts (accurate diastolic pressure difficult to measure)</li> <li>• Marked arrhythmia</li> <li>• Marked drop in diastolic pressure</li> <li>• Diastolic pressure difficult to measure</li> <li>• Improper cuff position or attachment</li> <li>• too few pulses detected</li> <li>• weak or unusual blood circulation</li> <li>• may give systolic value</li> </ul>	Check patient condition and retry. Check any leaks and retry. Use proper size of cuff. Check attachment.
Call service Error X-message	NIBP hardware error. X = error number.	See the description of the error message code, the causes and the solutions listed in the next chapter.

TROUBLE	CAUSE	TREATMENT
Cuff loose-message	<ol style="list-style-type: none"> <li>1. Hose and/or cuff not connected.</li> <li>2. Hose and cuff connected. Reason:                             <ul style="list-style-type: none"> <li>• cuff loosely wrapped</li> <li>• leakage in cuff or hose</li> <li>• leakage inside unit</li> <li>• pump does not work</li> <li>• no pulses during the last three measurements</li> </ul> </li> </ol>	<ol style="list-style-type: none"> <li>1. Connect the hose and the cuff.                             <ul style="list-style-type: none"> <li>• tighten the cuff</li> <li>• replace cuff/hose</li> <li>• check internal tubing and air chamber, and fix if necessary</li> <li>• check pump connector; if OK, replace pump</li> <li>• check cuff positioning</li> </ul> </li> </ol>
Air leakage-message	<ol style="list-style-type: none"> <li>1. Hose or cuff leaking. Reason:                             <ul style="list-style-type: none"> <li>• cuff damaged</li> <li>• cuff connector damaged</li> <li>• O-ring damaged or missing</li> <li>• hose double connector damaged</li> </ul> </li> <li>2. Hose and cuff OK. Reason:                             <ul style="list-style-type: none"> <li>• leakage inside the unit</li> <li>• tube disconnected or damaged</li> <li>• air chamber leaking</li> <li>• tubes or valve(s) damaged</li> </ul> </li> </ol>	<ol style="list-style-type: none"> <li>1. Replace cuff                             <ul style="list-style-type: none"> <li>• Replace cuff connector (if the fault is in hose connector, replace hose)</li> <li>• Replace O-ring</li> </ul> </li> <li>2. Connect or replace tube                             <ul style="list-style-type: none"> <li>• Replace the whole tubing</li> <li>• fix connections</li> <li>• replace valve(s)</li> </ul> </li> </ol>
Unable to measure Sys-message	Systolic blood pressure probably higher than the maximum inflation pressure.	Automatic retrial with increased pressure.



<b>TROUBLE</b>	<b>CAUSE</b>	<b>TREATMENT</b>
Cuff occlusion-message	<p>1. Cuff and/or hose occluded. Reason:</p> <ul style="list-style-type: none"> <li>• cuff tube kinked</li> <li>• tube inside module kinked</li> <li>• occlusion inside/outside module</li> </ul> <p>2. Cuff, hose, and tubes OK. Reason:</p> <ul style="list-style-type: none"> <li>• fault in pressure transducer</li> <li>• fault in A/D converter</li> <li>• faulty calibration</li> <li>• missing voltages</li> </ul>	<ul style="list-style-type: none"> <li>• straighten tube</li> <li>• remove occlusion</li>   <li>• replace the NIBP board</li> <li>• check calibration</li> <li>• recalibrate</li> </ul>
Calibration switch on -message	EEPROM protection switch at the bottom of the module is pressed.	Enables setting the protection OFF in the Calibration menu. Release switch if you are not going to calibrate.
Calibration not protected -message.	Calibration protection is set to OFF.	

## NIBP error code explanation

CODE	EXPLANATION
0	RAM failure Memory failure. Change NIBP board.
1	ROM checksum error Memory failure. Change NIBP board.
2	+12V failure Check short circuits. Change NIBP board.
3	-12V failure Check short circuits. Change NIBP board.
6	ADC error ADC circuit failure. Change NIBP board.
7	Watchdog time too short Change NIBP board.
8	Watchdog time too long Change NIBP board.
9	Watchdog activated Change NIBP board.
10	EEPROM checksum error Memory failure. Change NIBP board.
11	Auto zero range exceeded Calibrate NIBP.
12	Communication break Temporal break down of communication from monitor detected. Automatic recovery.
14	Too early Auto Start (needs 25 seconds without pressure)

**ECG**

<b>TROUBLE</b>	<b>CAUSE</b>	<b>TREATMENT</b>
HR numerical display shows '---'	No heart rate available.	<ol style="list-style-type: none"> <li>1. If no ECG waveform, check LEADS OFF message and connect the leads.</li> <li>2. If ECG waveform exists, check heart rate source e.g. in the ECG+RESP: ECG Setup.</li> </ol>
Unacceptable ECG waveform	<ol style="list-style-type: none"> <li>1. Poor electrode or poor electrode skin contact.</li> <li>2. Poor electrode condition.</li> </ol>	<ol style="list-style-type: none"> <li>1. Electrodes from different manufacturers are used.</li> <li>2. Too much/little gel is used.</li> <li>3. Electrodes are dried out.</li> </ol>
	<ol style="list-style-type: none"> <li>3. Improper site of electrodes.</li> </ol>	Check that electrodes are not placed over bones, active muscles, layers of fat.
	<ol style="list-style-type: none"> <li>4. Improper skin preparation.</li> </ol>	Remove body hair. Clean attachment site carefully with alcohol.
	No ECG trace	Waveform not selected on screen.
Noise-message	High frequency or 50/60 Hz noise.	Isolate noise source.

**Pulse oximetry (SpO<sub>2</sub>)**

<b>TROUBLE</b>	<b>CAUSE</b>	<b>TREATMENT</b>
Message 'NO PROBE'	<ol style="list-style-type: none"> <li>1. No probe connected to the monitor.</li> <li>2. Probe faulty.</li> </ol>	<ol style="list-style-type: none"> <li>1. Check probe connections.</li> <li>2. Change the probe.</li> </ol>
Message 'PROBE OFF' though probe properly attached to the patient	<ol style="list-style-type: none"> <li>1. Unsuitable site.</li> <li>2. Probe faulty.</li> <li>3. Probe connection cable not connected to probe.</li> </ol>	<ol style="list-style-type: none"> <li>1. Try another site.</li> <li>2. Try another probe.</li> <li>3. Connect the cable to probe.</li> </ol>
Finger probe falls off	<ol style="list-style-type: none"> <li>1. Probe is slippery.</li> <li>2. Finger is too thin or thick.</li> </ol>	<ol style="list-style-type: none"> <li>1. Wipe with 70 % isopropyl alcohol and allow to dry.</li> <li>2. Try other fingers, or other probe types.</li> </ol>
Weak signal artifacts	<ol style="list-style-type: none"> <li>1. Poor perfusion.</li> <li>2. Movement artifacts.</li> <li>3. Shivering.</li> </ol>	Try another place.
Message 'NO PULSE'	Pulse search > 20 sec. and low SpO <sub>2</sub> or low pulse rate.	Try other fingers.
Message 'ARTIFACT'	Pulse modulation exceeds the present scale.	Try another place or another probe.
Message 'CHECK PROBE'	DC value not in balance.	Try another probe.
Message 'POOR SIGNAL'	Modulation (Red or Ired) < 0.25 %.	Patient may be cold.
Message 'FAULTY PROBE'	Probe is faulty.	Change the probe.
No SpO <sub>2</sub>	No waveform selected on screen.	Check selected SpO <sub>2</sub> waveforms by entering Main Menu: Monitor Setup: Waveform Fields and selecting modify waveforms.

**Temperature**

<b>TROUBLE</b>	<b>CAUSE</b>	<b>TREATMENT</b>
Message 'TEMPERATURE ERROR'	Faulty calibration.	Perform calibration. If it does not help, check that front panel connector is properly connected to LM-STP board. Check front panel, or LM-STP board.
No temperature displayed	Wrong type of probe. Temperature out of measurable range.	Use correct probe. The range is between 10 and 45 °C. With German monitor software, check that Protection is set to ON in the Service Menu.

**Invasive blood pressure**

<b>TROUBLE</b>	<b>CAUSE</b>	<b>TREATMENT</b>
Abnormally low pressure	Transducer wrongly positioned.	Check mid-heart level and reposition transducer.
No pressure	Defective transducer.	Check transducer.
	No waveform selected on screen.	Check selected pressure waveforms by entering Main Menu: Monitor Setup: Waveform Fields and selecting waveforms. Check that pressure transducer open to patient.

TROUBLE	CAUSE	TREATMENT
	Wrong configuration setting	Check the monitor configuration setting from the Install/Service /Service View/Modules/ESTP:STP. Monitor type with Invasive Blood Pressure(s) is F_LMP1 or ...
Not zeroed-message	Measurement on, channel not zeroed.	Zero the channel.
Zeroing failed-message	Unsuccessful zeroing of P1 /P2 (number field).	Possibly due to pulsating pressure waveform. Open the transducer to air and zero the channel.  Offset is > 150 mmHg. Open the transducer to air and zero the channel.  Defective transducer. Replace it and zero the channel.
Calibration failed-message	Unsuccessful calibrating of P1/P2 (number field), possibly due to pulsating waveform	Turn the transducer to sphygmomanometer and try again (zeroing takes place first).  Gain is beyond the limits ( $\pm 20\%$ of the default gain). Replace the transducer.
Out of range < 40 mmHg	Measurement pressure is beyond measurement range.	Check transducer level. Zero the channel.
Out of range > 320 mmHg	Measurement pressure is beyond measurement range.	Check transducer level. Zero the channel. The patient may also have high pressure.
Zero adj. > 100 mmHg	Offset when zeroing is > 100 mmHg (but < 150 mmHg) from the absolute zero of the module (with default gain).	Check transducer. The waveform may hit the top and the numeric display not shown.
Out of range	Measured pressure is beyond the internal measurement range of the invasive pressure measurement.	The waveform hits the top and the numeric display not shown. Check transducer and its level. Zero the channel.

**Impedance respiration**

<b>TROUBLE</b>	<b>CAUSE</b>	<b>TREATMENT</b>
No resp trace	Waveform not selected on the screen	Enter the menu: Main Menu: Monitor Setup: Waveform fields and make adjustments
Unacceptable resp waveform	Poor electrode or poor electrode skin contact  Poor electrode condition  Improper site of electrodes  Improper skin preparation	Electrodes from different manufacturers are used. Too much/little gel is used.  Electrodes are dried out.  Check that electrodes are not placed over bones, active muscles, layers of fat.  Remove body hair. Clean attachment site carefully with alcohol.
Message: SMALL RESP CURVE	Respiration signal is very small	With 3-lead cable try another lead connection I, II, III or try 5-lead cable.
Message: APNEA ALARM, and respiration waveform normal	Respiration source is CO <sub>2</sub>	Check respiration source and change it to correct one.

### 3.1.2 NIBP Troubleshooting

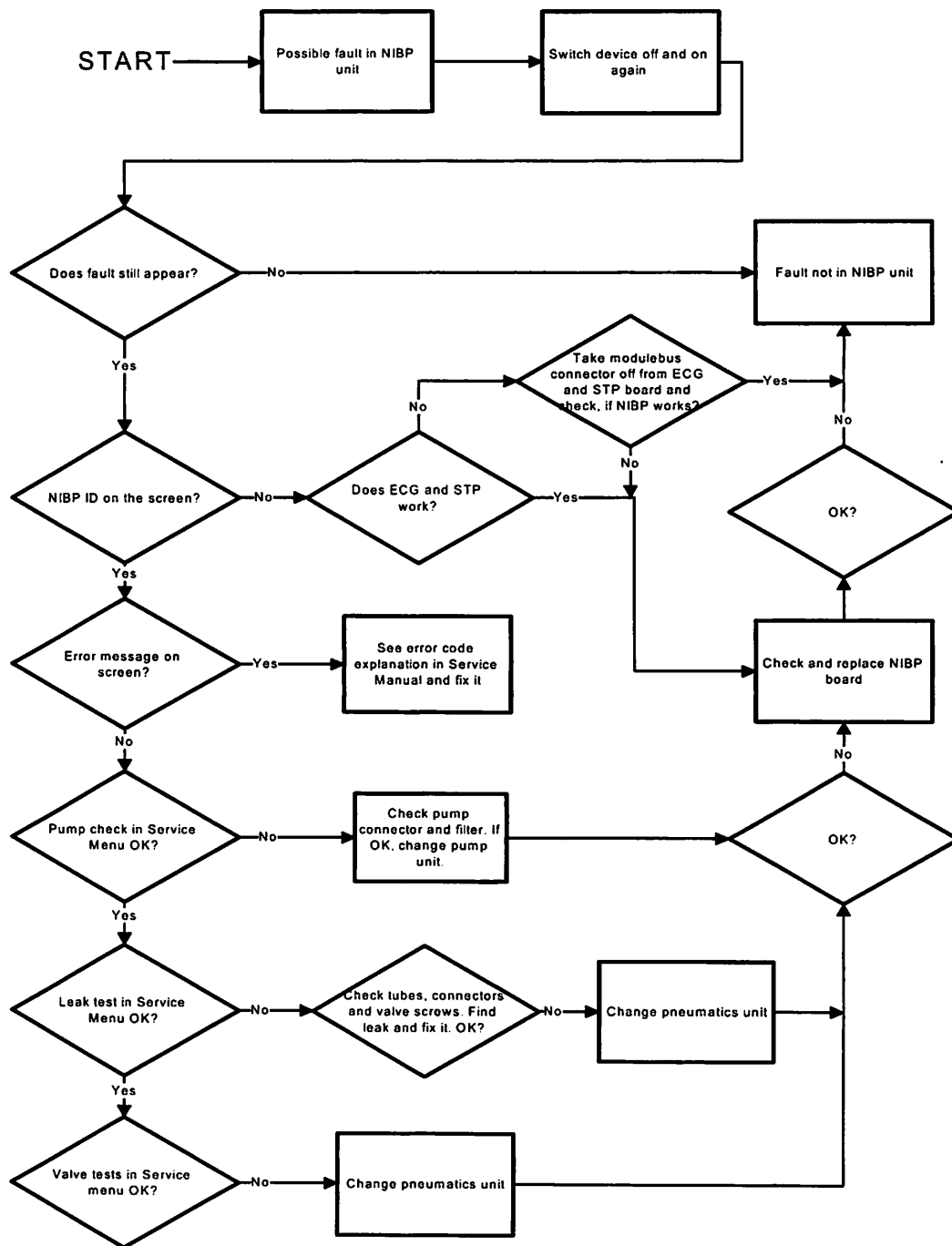
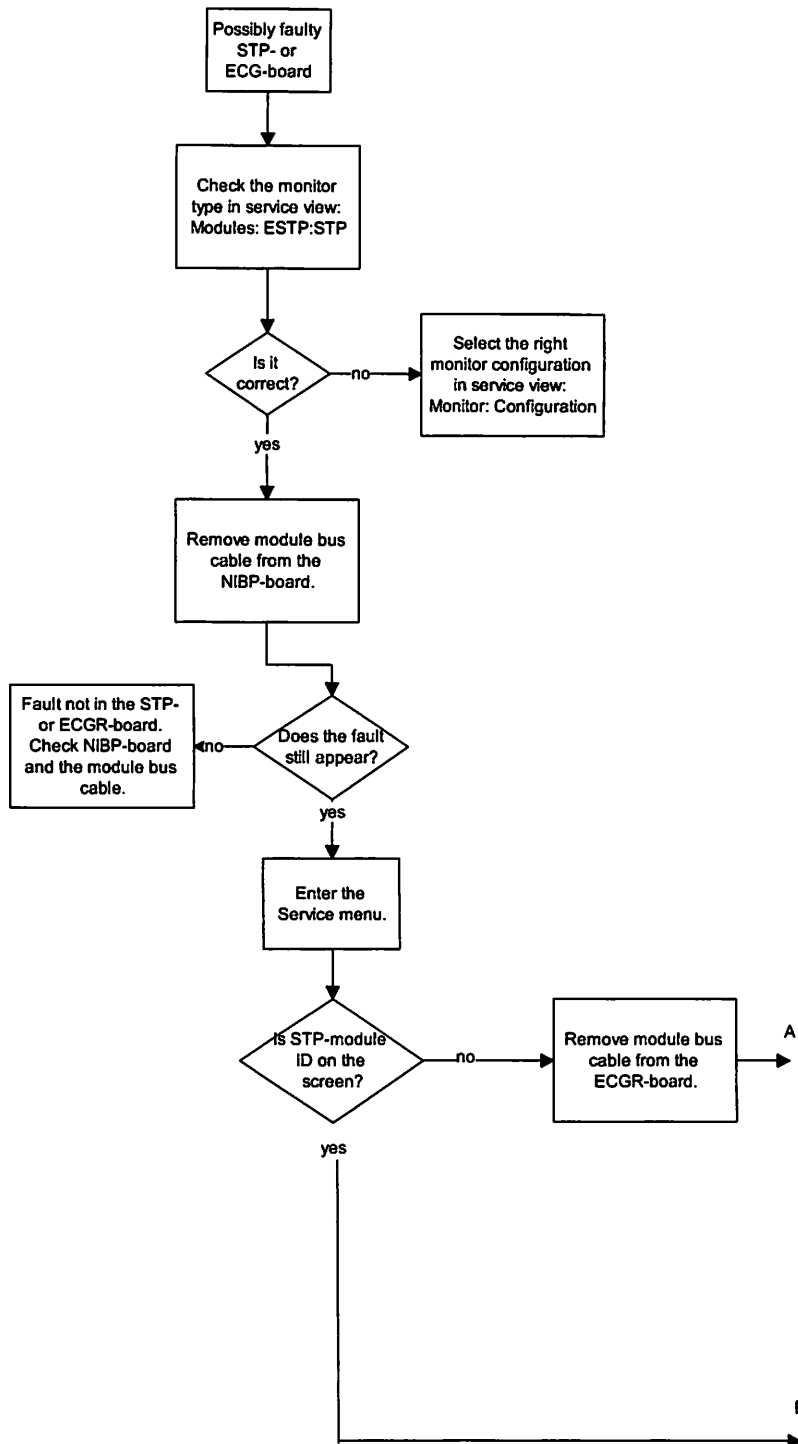


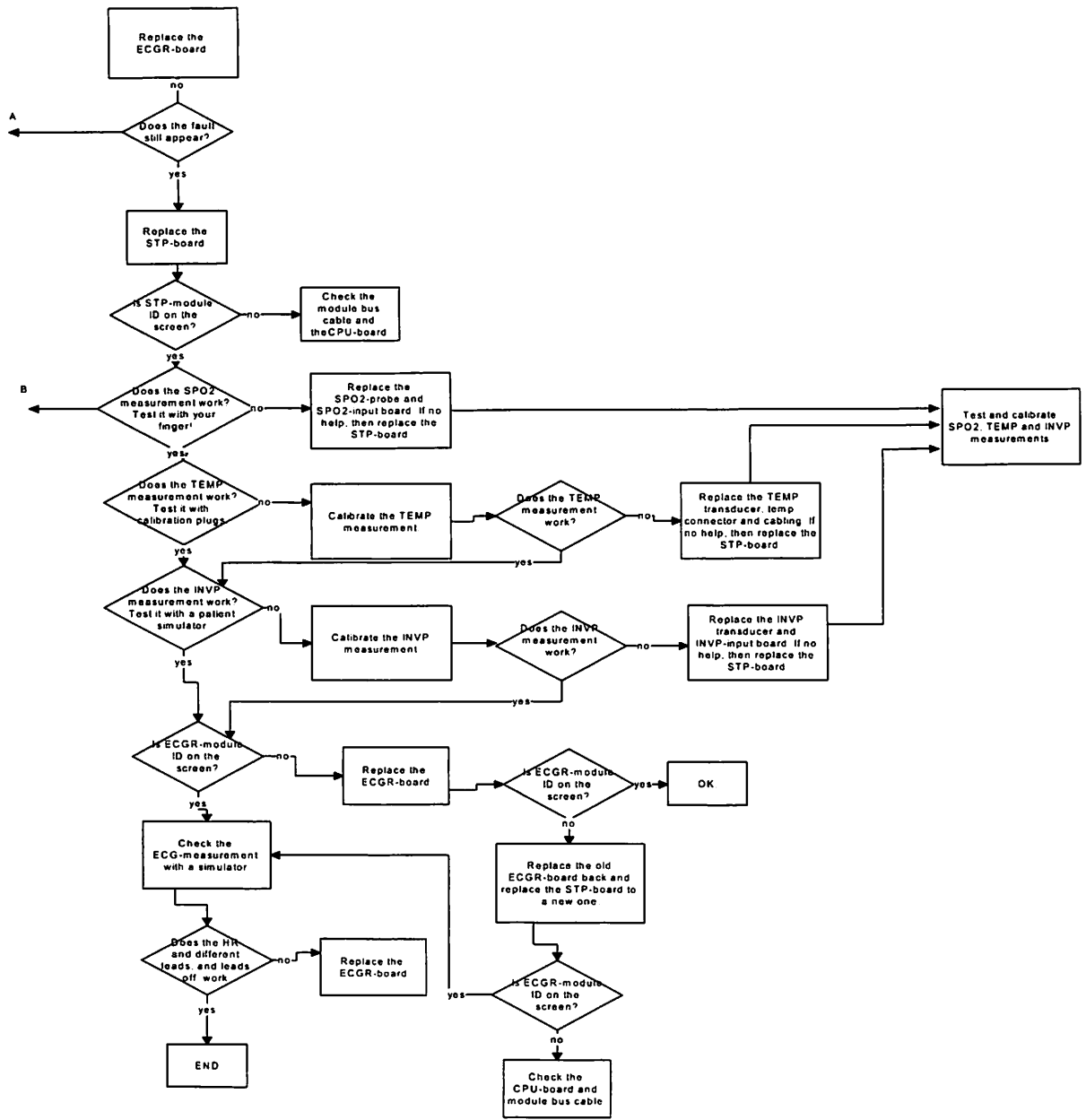
Figure 11 NIBP troubleshooting flowchart



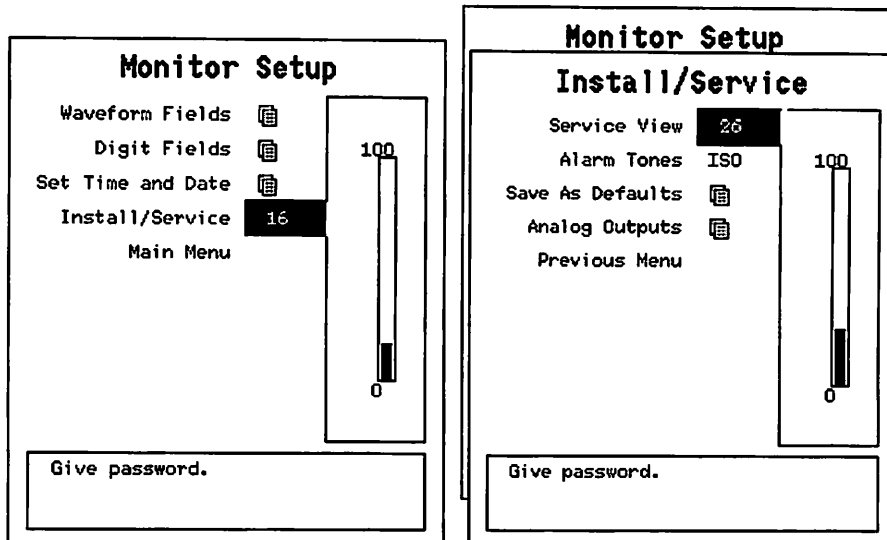
### 3.1.3 LM-STP and LM-ECG board troubleshooting



**Figure 12 LM-STP and LM-ECG board troubleshooting flowchart (continues next page)**



## 4 SERVICE MENU



1. Press **Menu** key.
2. Select **Monitor Setup - Install/Service** (password 16-4-34).
3. Select **Service View** (password 26-23-8).
4. Select **Modules**.

## 4.1 NIBP service menu

NIBP Module		Service Data			
Calibrations	Pressure	B1	B2		
Safety Valve	Zero	---	---		
Pulse Valve				AD0	---
				AD1	---
				AD2	---
				AD3	---
				AD4	---
Pneumatics	Protect handle	OFF		AD5	---
Watchdog	Calibr. prot.	OFF		AD6	---
Previous Menu	+12 V power	OFF		AD7	---
	Timeouts	65535	RAM		?
	Bad checksums	65535	ROM		?
	Bad c-s by mod	0	EEPROM		?

### Service data

**Pressure** shows measured pressure multiplied by 10.

**Zero** shows pressure at auto zeroing multiplied by 10 and changes between +20 and -20 mmHg. Absolute pressure is the sum of **Pressure** and **Zero**.

**Protect handle** indicates hardware protection for EEPROM memory. It should be ON all the time in normal operation. If it is OFF data can not be read from or written to EEPROM, only the calibration protection can be set or reset by software. It can be turned to OFF by turning the toggle switch to the right at the bottom of the module, which also enables 'Protection ON/OFF' menu selection in the calibration menu.

**Calibr. prot.** shows software calibration protection and should be OFF to enable calibration.

**+12 V power** indicates the condition of the supply voltage +12 VD for the pump and valves. It exists (ON) or not (OFF) depending on service menu function.

**AD0 to AD7** show the values of each eight channels of A/D converter.

**Timeouts** is a cumulative number that indicates how many times the unit has not responded to the CPU's inquiry. **Bad checksums** is a cumulative number that indicates how many times communication from the unit to CPU broke down.

**Bad c-s by mod** is a cumulative number that indicates how many communication errors the unit has detected.

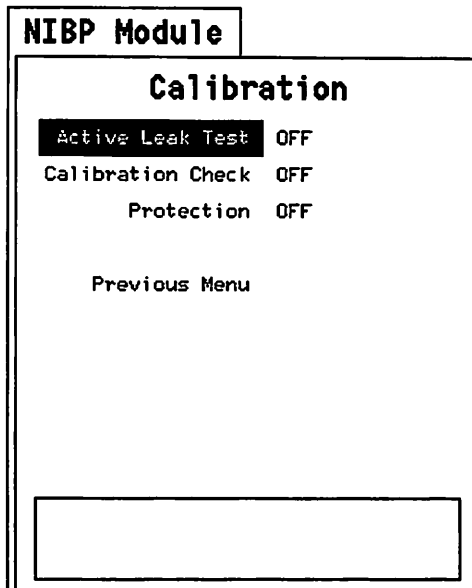
The Light Monitor starts counting these items at power up and resets to zero at power off. The nonzero values do not indicate a failure, but the continuous counting (more than 50 per second) indicates serial communication failure. Also other units can cause communication errors that cause these numbers rise.

**RAM** indicates the state of the external RAM memory.

**ROM** indicates whether the checksum in the EPROM is in accordance with the one the software has calculated.

**EEPROM** indicates if the values stored in the permanent memory are valid. The state is either **OK**, **Fail** or **?** (unit not in place or a communication error).

### 4.1.1 NIBP calibration menu



#### Active leak test

Wrap an adult cuff around a pipe and connect the cuff to the module. Select the active leak test (ON). The module automatically pumps a pressure of 260 mmHg into the cuff. Wait for several seconds until the pressure stabilizes. Then check that the pressure reading does not drop more than 6 mmHg per minute. If it does, leaking point(s) should be detected and fixed. Cancel the test by selecting Active leak test OFF.

#### Calibration check

After the calibration check is selected (ON), manually pump pressure into the module and make sure that the same pressure values are shown both on the display and on manometer. Pressure of both pressure channels B1 and B2 are shown. Note that if the display shows +2 mmHg at zero pressure and if you pumped +200 mmHg into the module, the display should show +202 mmHg.

#### Protection

Software calibration protection (ON/OFF). Select OFF when calibrating. Protection can be set to ON or OFF only when the switch at the bottom of the unit is pressed.

---

## Calibration

Calibration selection is available only when protection is OFF.

NIBP calibration can be performed in the NIBP Service menu as follows:

**NOTE:** Both channels B1 and B2 must be calibrated simultaneously.

1. If **Protection** is ON change it to OFF by first pressing the switch at the bottom of the monitor, which enables the **Protection** selection. Then release the switch to enable **Calibration**.

**NOTE :** If there is the battery frame installed do disconnect it.

**NOTE:** When the switch is pressed, the NIBP field shows an error message "Calibration switch on!".

**NOTE:** When calibration is enabled, a message 'Calibration not protected' appears.

2. For proper zeroing to take place, remove the hose from the front panel connector. Select **Calibration** and push the ComWheel. Messages "ZEROING" and "ZEROED" will appear in the NIBP message field. After this a pressure bar will appear beside the menu.
3. Connect an external mercury manometer with pump to module through the both tubes of the hose. Pump up to about 200 mmHg pressure (range of 150 to 300 mmHg allowed) according to the manometer. Verify that both pressure values in the prompt field match the manometer reading. If not, adjust by turning the ComWheel.
4. When the values are equal, push the ComWheel to confirm the calibration. First the message "Calibrating" will appear followed after a few seconds "Calibrated", which means that the calibration data has now been saved.
5. Use the switch to enable **Protection** setting and set it ON, and finally disable **Protection** setting.

### 4.1.2 NIBP safety valve menu

Safety Valve		Safety Valve Data			
<b>ADULT</b>			B1	B2	
Start Test	Pressure		---	---	
Previous Menu	Zero		---	---	
				AD0	---
				AD1	---
				AD2	---
				AD3	---
				AD4	---
	Protect handle	OFF		AD5	---
	Calibr. prot.	OFF		AD6	---
	+12 V power	OFF		AD7	---
			B1	B2	
	Max press		0	0	
	2 s after stop		0	0	
	Timeouts	65535	RAM	?	
	Bad checksums	65535	ROM	?	
	Bad c-s by mod	0	EEPROM	?	

#### ADULT/INFANT

Selection of patient.

#### Start test

**Start test** is for starting and **Stop test** is for stopping the Safety Valve test.

**NOTE:** Parameter values in Service Data are for reference only.

#### Safety valve data

See NIBP Service menu in chapter 5.1 for information on general items **Pressure, Zero, Protect handle, Calibr. prot., +12 V power, AD0 to AD7** as well as **Timeouts** etc.

**Max. press** and **2 s after stop** show the measured values at Safety Valve test.

#### Safety Valve Test Adult/Infant

Wrap an adult cuff around a pipe and connect the cuff to the monitor. Highlight **Start test** and give the ComWheel a push. The test ends automatically or when **Stop test** (appears in place of **Start test**) is pushed. Select Adult/Infant and **Start test** once again. Result is usually **2 s after stop** 150 mmHg.

**Max. press** indicates the pressure at which the safety valve opens and is normally  $305 \pm 15$  mmHg. **2 s after stop** indicates the pressure at 2 seconds after the pump has stopped and is normally  $> 280$  mmHg. If the value is less, check leakage by the active leak test.

### 4.1.3 NIBP pulse valve menu

Pulse Valve	Pulse Valve Data			
Start Test	Pressure	B1	B2	
Set Valve	Zero	---	---	
Previous Menu			AD0	---
			AD1	---
			AD2	---
			AD3	---
			AD4	---
	Protect handle	OFF	AD5	---
	Calibr. prot.	OFF	AD6	---
	+12 V power	OFF	AD7	---
			Pulse Valve	150
	Interval 240 mmHg -> 50 mmHg			0 s
	Timeouts	65535	RAM	?
	Bad checksums	65535	ROM	?
	Bad c-s by mod	0	EEPROM	?

#### Start test

**Start test** is for starting and **Stop test** is for stopping the test.

#### Set valve

**Set Valve** lets you adjust the opening of the pulse valve.

**NOTE:** Parameter values in Service Data are for reference only.

#### Pulse valve data

See NIBP Service menu in chapter 5.1 for information on general items Pressure, Zero, Protect handle, Calibr. prot., +12 V power, AD0 to **AD7** as well as **Timeouts etc.**

#### Pulse valve checking

Wrap an adult cuff around a pipe and connect the cuff to the monitor. Select the **Start test** and push the ComWheel. The pressure rises beyond 240 mmHg and stops. The pulse valve opens. The module counts the time it takes for the pressure to go down from 240 mmHg to 50 mmHg and displays it. The test can be manually stopped by selecting **Stop test**.

The valve can be adjusted between 0 and 255 (0 for fully closed and 255 for fully open). First select Set Valve and push the ComWheel. See the pulse valve value and adjust it by turning the ComWheel. Then push the ComWheel to confirm the value.

The "**Interval 240 mmHg -> 50 mmHg**" time should be less than 60 seconds when the valve is '150' and less than 10 when fully opened (255). When fully closed (0), the system should be airtight and the pressure does not drop. Depending on an individual, the pulse valve may remain closed up to approx. value 100.

If the measured time deviates much from those above, then the pulse valve or its tubes are faulty.



### 4.1.4 NIBP pneumatics menu

Pneumatics		Pneumatics Data			
Start Pump		Pressure	B1	B2	
Open Exh2		Zero	---	---	
Open Exh1				AD0	---
Open Zerovalve				AD1	---
Set Valve				AD2	---
Reset Clock		Protect handle	OFF	AD3	---
Previous Menu		Calibr. prot.	OFF	AD4	---
		+12 V power	OFF	AD5	---
				AD6	---
				AD7	---
		Pump	Exh2	Exh1	Pulse
		OFF	Valve	Valve	Valve
			CLOSED	CLOSED	0
		Interval	20 mmHg	->	185 mmHg
					0 s
		Timeouts	65535	RAM	?
		Bad checksums	65535	ROM	?
		Bad c-s by mod	0	EEPROM	?

#### Set valve

With **Set Valve**, the opening of the pulse valve is adjusted between 0 and 255 (0 for fully closed and 255 for fully open). First push the ComWheel, then turn it to adjust the value on screen and finally push to set the value.

#### Reset clock

**Reset Clock** will zero the time on the display.

**NOTE:** Parameter values in Service Data are for reference only.

#### Pneumatics data

See NIBP service menu in chapter 5.1 for information on general items **Pressure, Zero, Protect handle, Calibr. prot., +12 V power, AD0 to AD7** as well as **Timeouts** etc.

**Pump, Exh1 Valve, and Exh2 Valve** show their states.

**Pulse Valve** shows how much the valve is opened (0 to 255) during Valve Setting.

#### Interval 20 mmHg -> 185 mmHg Checking

Select the **Start pump** at different combinations of the valves open/closed and push the ComWheel. The module counts the time it takes for the pressure to go up from 20 mmHg to 185 mmHg and displays it. When all the valves are closed, the pump should be able to pump the pressure in about 1 to 4 seconds into an adult cuff wrapped around a pipe. The pump does not stop without selecting the **Stop Pump** by pushing the ComWheel.

**Watchdog BEEP**

Connect manometer to the front panel and pump pressure into the module. When the AD5 value changes from negative to positive value (at about 11 mmHg) a beep is heard. This is the watchdog threshold pressure. Beyond this pressure the watchdog is active and cut pressures at about 2 min. (adult).

**4.1.5 NIBP watchdog menu**

Watchdog	Watchdog Data		
Test ADULT	Pressure	B1	B2
Test INFANT	Zero	---	---
Stop Test			AD0 ---
Previous Menu			AD1 ---
			AD2 ---
			AD3 ---
			AD4 ---
	Protect handle	OFF	AD5 ---
	Calibr. prot.	OFF	AD6 ---
	+12 V power	OFF	AD7 ---
	Watchdog Interval	0 s	
	Timeouts	65535	RAM ?
	Bad checksums	65535	ROM ?
	Bad c-s by mod	0	EEPROM ?

**Test ADULT**

**Test ADULT** is to test watchdog timer in adult mode (120 to 140 seconds).

**Test INFANT**

**Test INFANT** is to test watchdog timer in infant mode (about 60 to 70 seconds).

**Stop test**

Stop Test is for stopping the test.

**NOTE:** Parameter values in Service Data are for reference only.

**Watchdog data**

See NIBP Service menu in chapter 5.1 for information on general items **Pressure, Zero, Protect handle, Calibr. prot., +12 V power, AD0 to AD7** as well as **Timeouts etc.**

**Watchdog Interval** shows the time the +12 Vdirty stays on during the test.

**Adult watchdog time testing**

Select Test ADULT and push the ComWheel. Watchdog interval starts counting up seconds and keeps on counting as long as the +12 VD is on. The time should be 120 to 140 seconds.

**Infant watchdog time testing**

Select Test INFANT and push the ComWheel. Watchdog interval starts counting up seconds and keeps on counting as long as the +12 VDy is on. The time should be 60 to 70 seconds.

## 4.2 ECG service menu

ECG Module	Service Data			
Power Freq	Power freq	50 Hz		
Filter Low	Filter low	0.50 Hz	high	30 Hz
Filter High	Cable type	3 lead		
Previous Menu	Quick zero	OFF	OFF	OFF
	Cable	ON		
	Electrode	RA	L <sub>f</sub>	LL 4 RL
		ON	ON	ON OFF OFF
	Pacer count	0		
	Resp Available	OFF		
	Measurement	ON		ON
	Amp Zero	OFF		
	Value	---		
	Timeouts	0	RAM	Fail
	Bad checksums	0	ROM	Fail
	Bad c-s by mod	0	EEPROM	Fail

### Power freq

Set power frequency (50 Hz/60 Hz)

### Service data

**Power freq**, and **Cable type** show the values chosen or detected. Permanent **filter** setting is: **low 0.50 Hz. High 30 Hz** depends on **Power freq** setting.

**Quick zero** is ON when the signal in any of the three internal amplifier goes beyond scale, and therefore, a capacitor connected to the related channel discharges overvoltage. At least one of **Quick zero** values is OFF when 3-lead cable is used. All three values are OFF when 5-lead cable is used. **Quick zero** also takes place when lead is changed in 3-lead measurement.

**Cable** shows ON when an ECG cable is connected.

**Electrode** shows ON when each of these electrodes are connected.

**Pacer count** is a running number for pacemaker users.

**Resp Available** indicates that ECG hardware is capable of measuring impedance respiration.

**Measurement** shows ON when the respiration measurement is on.

**Amp zero** shows ON when zeroing of the respiration amplifier takes place.

Waveform **VALUE** will be updated in one second interval.

**Timeouts** is a cumulative number that indicates how many times the module has not responded to the monitor's inquiry. **Bad checksums** is a cumulative number that indicates how many times communication from the module to monitor broke down.

**Bad c-s by mod** is a cumulative number that indicates how many communication errors the module has detected.

The Light Monitor starts counting these items at power up and resets to zero at power off. The nonzero values do not indicate a failure, but the continuous counting (more than 50 per second)

indicates either serial communication failure, or LM-ECG/LM-NIBP not in place. Also other modules can cause communication errors that cause these numbers rise.


**RAM** indicates the state of the external RAM memory.

**ROM** indicates whether the checksum at the EPROM is in accordance with the one the software has calculated.

**EEPROM** indicates if the values stored in the permanent memory are valid.

The state is either **OK**, **Fail** or **?** (module not in place or a communication error).

### 4.3 STP service menu

ESTP Module		Service Data		
Calibrations  Previous Menu	Gain	P1	P2	T1
	Zero	---	---	---
	Cable	ON	ON	ON
	Probe	ON	ON	ON
	Value	---	---	---
	Monitor type: MON_LMP_C02			
	SpO2	97.00		
	Modpr	14.00		
	Hr	58		
	Cable	ON		
Probe	ON			
OK				
ch1 press filt	len	1		
ch2 press filt	len	5		
Protect key		OFF		
Protect mode		OFF		
Timeouts	65535	RAM	?	
Bad checksums	65535	ROM	?	
Bad c-s by mod	0	EEPROM	?	

#### Service data

**Gain** is a coefficient to compensate gain error. Usually the values for P1 and P2 are between 17000 and 25000 and for T1 between 13000 and 14300. **Zero** indicates offset compensation value of each parameter in A/D converter. Typically the values for P1 and P2 are within  $\pm 1000$  and for T1 between -150 and +300. Calibrate if zero and/or gain value is outside the ranges.

**Cable** shows ON when a corresponding cable is connected to the front panel and **Probe** shows ON when a corresponding probe is connected to the cable.

Under **Value** the measured numeric values are displayed simultaneously. Pressure values are real time values and shown in mmHg. Temperature values are shown in Centigrade.

**SpO2** shows measured beat-to-beat SpO2 value. **Modpr** is a modulation % that indicates AC/DC ratio in the measured signal. **Hr** is a pulse rate calculated from every beat.

**Cable** and **Probe** can be either OFF or ON, and these indicate the state PROBE OFF.

Under them there is a message field for SpO2. It can be OK, PULSE SEARCH, NO PROBE, PROBE OFF, NO PULSE, ARTEFACT, POOR SIGNAL, or CHECK PROBE.

**Protect key** shows normally OFF but turns to ON when the button at the bottom of the monitor is pressed.

**Protect mode** is normally ON. It turns to OFF when Protect is switched to OFF for the temperature calibration in Calibration Menu.

**Timeouts** is a cumulative number that indicates how many times the module has not responded to the monitor's inquiry. **Bad checksums** is a cumulative number that indicates how many times communication from the module to monitor broke down.

**Bad c-s by mod** is a cumulative number that indicates how many communication errors the module has detected.

The Light Monitor starts counting these items at power up and resets to zero at power off. The nonzero values do not indicate a failure, but the continuous counting (more than 50 per second) indicates either serial communication failure, or board not in place. Also LM-NIBP/LM-STP can cause communication errors that cause these numbers rise.

**RAM** indicates the state of the external RAM memory.

**ROM** indicates whether the checksum at the EPROM is in accordance with the one the software has calculated.

**EEPROM** indicates if the values stored in the permanent memory are valid.

The state is either **OK**, **Fail** or **?** (module not in place or a communication error).

### 4.3.2 Calibration menu

Calibrations	
Protection	OFF
Set Config	STP
Calibrate T1	
Calibrate P1	
Calibrate P2	
Previous Menu	

Calibrate temperatures with calibration plugs for 25 °C and 45 °C.
--

#### Protection

**Protection** can be set to ON or OFF only when protect button at the bottom of the LM-STP board is pressed.

#### Set config, calibrate T1

**Set Config** and **Calibrate T1** selections are available only when protect mode is off.

#### Calibrate P1 and calibrate P2

**Calibrate P1** and **Calibrate P2** are available when pressure transducer is connected to the receptacle on the front panel.

For calibration instructions, please see Chapter 2.3 Adjustments and Calibrations.

**APPENDIX A**





# PREVENTIVE MAINTENANCE CHECK FORM, LM-NIBP, LM-ECG, LM-STP BOARDS

Customer	_____	
Service	_____	
Service engineer	_____	Date _____

OK = Test OK

N.A. = Test not applicable

Fail = Test Failed

<b>All boards</b>								
		OK	N.A.	Fail		OK	N.A.	Fail
1. Internal parts		<input type="checkbox"/>	<input type="checkbox"/>	<input type="checkbox"/>	2. External parts	<input type="checkbox"/>	<input type="checkbox"/>	<input type="checkbox"/>
3. NIBP pump filter		<input type="checkbox"/>	<input type="checkbox"/>	<input type="checkbox"/>	4. Parameter information	<input type="checkbox"/>	<input type="checkbox"/>	<input type="checkbox"/>
Notes _____								

<b>ECG measurement</b>								
5. Board software								
ECG/RESP	_____							
STP	_____							
NIBP	_____							
		OK	N.A.	Fail		OK	N.A.	Fail
6. Communication and memories		<input type="checkbox"/>	<input type="checkbox"/>	<input type="checkbox"/>	7. Power frequency	<input type="checkbox"/>	<input type="checkbox"/>	<input type="checkbox"/>
8. Cable recognition		<input type="checkbox"/>	<input type="checkbox"/>	<input type="checkbox"/>	9. Lead detection	<input type="checkbox"/>	<input type="checkbox"/>	<input type="checkbox"/>
10. 3-lead cable		<input type="checkbox"/>	<input type="checkbox"/>	<input type="checkbox"/>	11. Test with patient simulator	<input type="checkbox"/>	<input type="checkbox"/>	<input type="checkbox"/>
Notes _____								

<b>RESP measurement</b>				S/N		
12. RESP measurement recognition	<input type="checkbox"/>	<input type="checkbox"/>	<input type="checkbox"/>	13. Test with patient simulator	<input type="checkbox"/>	<input type="checkbox"/>
Notes _____						

<b>TEMP measurement</b>							
	OK	N.A.	Fail		OK	N.A.	Fail
14. Communication and memories	<input type="checkbox"/>	<input type="checkbox"/>	<input type="checkbox"/>	15. Temperature probe detection	<input type="checkbox"/>	<input type="checkbox"/>	<input type="checkbox"/>
16. Calibration check	<input type="checkbox"/>	<input type="checkbox"/>	<input type="checkbox"/>	17. Temp test -function	<input type="checkbox"/>	<input type="checkbox"/>	<input type="checkbox"/>
Notes _____							

<b>For F-LMP1 with the InvBP measurement</b>				S/N		
18. Cable and transducer detection	<input type="checkbox"/>	<input type="checkbox"/>	<input type="checkbox"/>	19. Calibration	<input type="checkbox"/>	<input type="checkbox"/>
20. Test with patient simulator	<input type="checkbox"/>	<input type="checkbox"/>	<input type="checkbox"/>			
Notes _____						

<b>SpO<sub>2</sub> measurement</b>				S/N		
21. SpO <sub>2</sub> probe detection	<input type="checkbox"/>	<input type="checkbox"/>	<input type="checkbox"/>	22. Test measurement	<input type="checkbox"/>	<input type="checkbox"/>
Notes _____						

<b>NIBP measurement</b>				S/N		
23. Communication and memories	<input type="checkbox"/>	<input type="checkbox"/>	<input type="checkbox"/>	24. Pump and valves	<input type="checkbox"/>	<input type="checkbox"/>
				Measured	Allowed range	
25. Leak test					< 6 mmHg/min	
26. Calibration check				Measured B1	Measured B2	Allowed range
0 mmHg						± 9 mmHg
100 mmHg						100 + z.o. ±2 mmHg
200 mmHg						200 + z.o. ±3 mmHg
260 mmHg						260 + z.o. ±4 mmHg
z.o. = zero offset at 0 mmHg pressure						

	Measured	Allowed range
27. Watchdog timer activation pressure		11-15 mmHg
28. Watchdog timer		
Adult		120-140 s
Infant		60-70 s
29. Safety valve feature		
	B1	B2
"Max press" ADULT		
"2 s after stop" ADULT		
"Max press" INFANT		
"2 s after stop" INFANT		
30. Cuff related messages	<input type="checkbox"/>	<input type="checkbox"/>
31. Adult cuff detection	<input type="checkbox"/>	<input type="checkbox"/>
32. Test measurement	<input type="checkbox"/>	<input type="checkbox"/>
33. Infant cuff detection	<input type="checkbox"/>	<input type="checkbox"/>
Notes		

For Light Monitor							
	OK	N.A.	Fail		OK	N.A.	Fail
34. Electrical safety check	<input type="checkbox"/>	<input type="checkbox"/>	<input type="checkbox"/>	35. Functioning after electrical safety check	<input type="checkbox"/>	<input type="checkbox"/>	<input type="checkbox"/>
36. Final cleaning	<input type="checkbox"/>	<input type="checkbox"/>	<input type="checkbox"/>		<input type="checkbox"/>	<input type="checkbox"/>	<input type="checkbox"/>
Notes							

Notes \_\_\_\_\_

Used Spare Parts \_\_\_\_\_

Signature \_\_\_\_\_

## **CO<sub>2</sub> UNIT**

Datex-Ohmeda, Inc.  
P.O. Box 7550, Madison  
WI 53707-7550, USA  
Tel. +1-608-221-1551  
Fax +1-608-222-9147  
[www.us.datex-ohmeda.com](http://www.us.datex-ohmeda.com)

Datex-Ohmeda Division,  
Instrumentarium Corp.  
P.O. Box 900, FIN-00031  
DATEX-OHMEDA, FINLAND  
Tel. +358 10 39411 Fax +358 9 146 3310  
[www.datex-ohmeda.com](http://www.datex-ohmeda.com)  
© Instrumentarium Corp. All rights reserved.

---

# TABLE OF CONTENTS

## CO<sub>2</sub> UNIT

<b>TABLE OF CONTENTS</b>	<b>i</b>
--------------------------	----------

<b>TABLE OF FIGURES</b>	<b>i</b>
-------------------------	----------

<b>1 Functional description</b>	<b>1</b>
1.1 General .....	1
1.2 Measurement principle .....	1
1.2.1 Mainstream CO <sub>2</sub> sensor .....	1
1.3 CO <sub>2</sub> module .....	3
1.3.1 Main processor board .....	3
1.3.2 Mainstream daughter board .....	4
1.3.3 Isolated power supply unit .....	4
1.3.4 Serial communication .....	4
1.4 Internal connectors .....	5
1.5 External connectors .....	6
<b>2 Service procedures</b>	<b>7</b>
2.1 General service information .....	7
2.2 Service check .....	7
2.2.1 Visual inspection .....	7
2.3 Adjustments and calibrations .....	8
2.3.1 CO <sub>2</sub> calibration check .....	8
<b>3 SERVICE MENU</b>	<b>10</b>
3.1 CO <sub>2</sub> module menu .....	10
3.1.2 Sensor menu .....	11
3.1.3 Pump menu .....	12

## TABLE OF FIGURES

Figure 1 CO <sub>2</sub> Measurement principle .....	1
Figure 2 Photodetector voltage .....	2
Figure 3 CO <sub>2</sub> measurement block diagram .....	3



# 1 FUNCTIONAL DESCRIPTION

## 1.1 General

CO<sub>2</sub> monitoring determines the carbon dioxide concentration in exhaled gas and converts this data to a carbon dioxide value and a corresponding waveform.

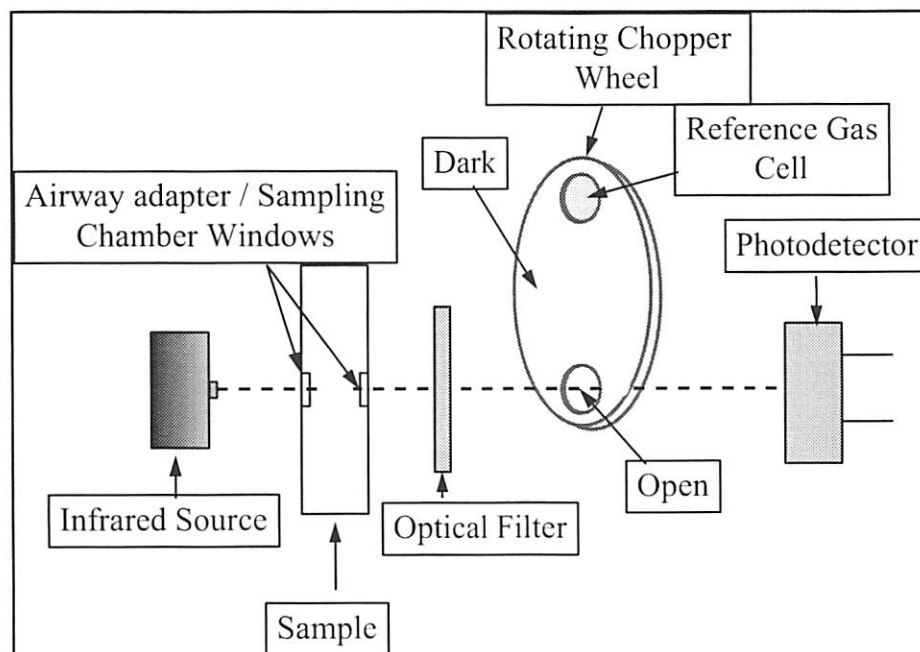
The CO<sub>2</sub> board is designed for use with Datex-Ohmeda sensors and cables.

## 1.2 Measurement principle

CO<sub>2</sub> measurement is based on the infra-red absorption characteristic of CO<sub>2</sub> molecules. The CO<sub>2</sub> sensor uses non-dispersive infra-red spectroscopy to measure the amount of CO<sub>2</sub> present at the end of exhalation (EtCO<sub>2</sub>). The sensor is optically tuned to measure the concentration of CO<sub>2</sub> molecules present in the airway adapter. Based on these sensor measurements, the CO<sub>2</sub> board calculates the end tidal and inspiratory CO<sub>2</sub> value, breaths per minute, and generates a corresponding waveform.

### 1.2.1 Mainstream CO<sub>2</sub> sensor

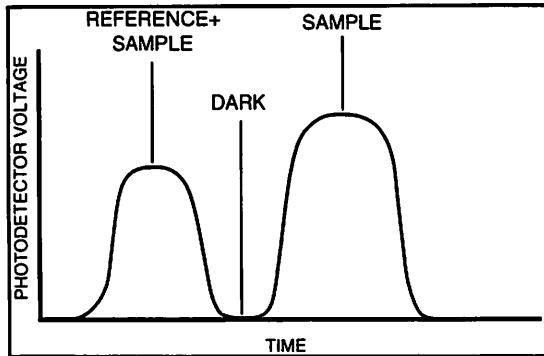
Mainstream measurement employs a CO<sub>2</sub> sensor and an airway adapter in the circuit of intubated patients. The CO<sub>2</sub> sensor has six basic components: an infra-red (IR) source, detector, chopper wheel, heater, thermistor, and non-volatile memory.



**Figure 1** CO<sub>2</sub> measurement principle

The IR source emits energy that is directed toward an IR detector. The detector generates a voltage based on the amount of energy it receives. In the IR path between the source and detector are three components: a filter, allowing only a specific IR wavelength to pass; the gas sample in the

airway adapter; and a chopper wheel with three distinct areas: a CO<sub>2</sub> reference cell, an opening, and a dark, or closed, area.



**Figure 2** Photodetector voltage

As the single IR beam encounters the three areas of the rotating chopper wheel and the airway sample, a signal is generated. A ratio of “reference + patient sample/patient sample” is used to determine the CO<sub>2</sub> concentration in the patient’s respiratory gas. The dark area of the chopper wheel provides a zero reference for recalibrating the detector with each rotation.

A heater is used to elevate the CO<sub>2</sub> sensor temperature to 42 °C to keep the airway windows clear of condensation and maintain a stable detector temperature. A thermistor provides temperature feedback to the heater control circuitry.



## 1.3 CO<sub>2</sub> module

The operating principle of the CO<sub>2</sub> module is illustrated in figure 3. The system can be divided into the following functional parts:

- Main Processor Board
- Mainstream daughter board
- Isolated Power Supply

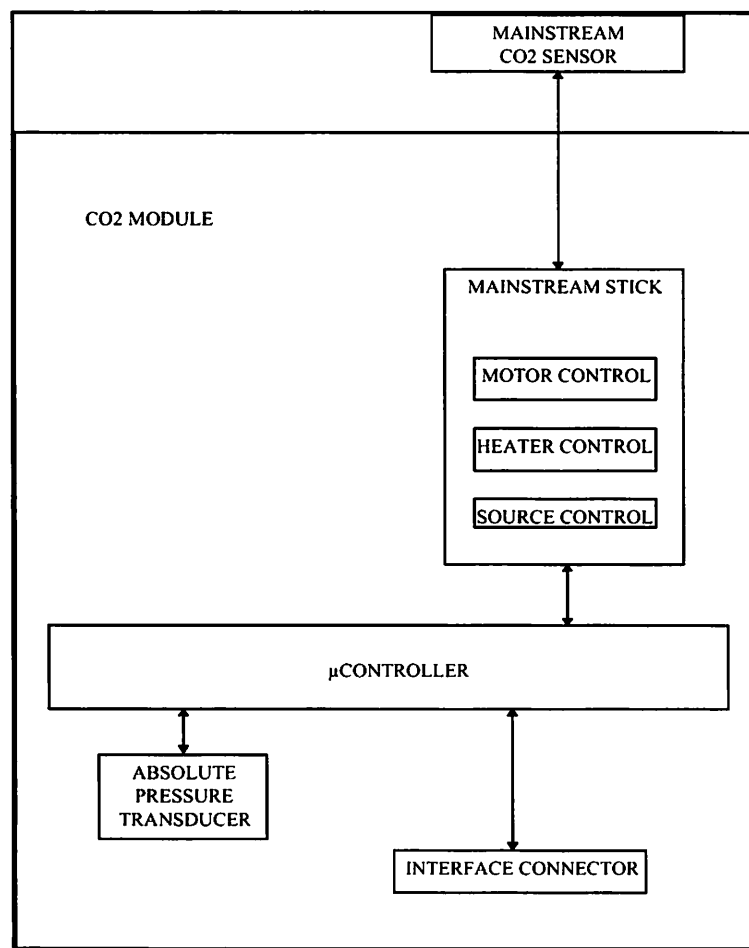


Figure 3 CO<sub>2</sub> measurement block diagram

### 1.3.1 Main processor board

The main processor board is based around a 68HC11K1 microprocessor. The processor controls the parameter measurement circuitry and sensor heater output. The processor also manages the communication with the CPU board.

### **1.3.2 Mainstream daughter board**

The mainstream daughter boards provides the interface to the mainstream sensor. The board provides the necessary control's to start and maintain sensor motor speed. The board also provides the necessary logic for detecting sensor fault.

### **1.3.3 Isolated power supply unit**

Please see the next slot (5) "Isolation Power Supply Unit for CO<sub>2</sub> Unit".

### **1.3.4 Serial communication**

The CO<sub>2</sub> module, manufactured by Pryon Corp., is used in the Light Monitor for CO<sub>2</sub> measurement. Communication with the host is provided by an asynchronous serial link. Signals used in the communication are TXDC, RXDC. The TXDC signal is transmit line from host to CO<sub>2</sub> modules and the RXDC signal is a receive line from CO<sub>2</sub> module to host.

## 1.4 Internal connectors

### Connector for CO<sub>2</sub> module, (P105 on DuET board)

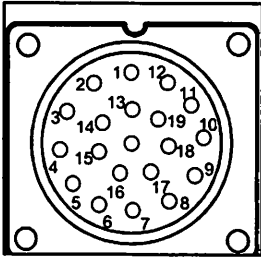
Pin	Signal	Function
1	+ 10 V	Input Power
2	GND	Ground
3	TxD	Data from CO <sub>2</sub> board to Host
4	RxD	Data from Host to CO <sub>2</sub> board

### Mainstream flex circuit header, (P302 on MS-Stick)

Pin	Signal	Function
1	- 5 Volts	- 5 Volt Supply
2	- Bias	Sensor Detector Minus Bias
3	GND	Signal Ground
4	Heater	Heater Voltage
5	Heater	Heater Voltage
6	GND	Signal Ground
7	Heater GND	Heater Ground
8	Heater GND	Heater Ground
9	Source	Source Current Supply
10	EEPROM CS	Sensor EEPROM Chip Select
11	+ 5 Volts	+ 5 Volts
12	EEPROM DATA	Sensor EEPROM Data
13	Detector	Sensor Detector Output
14	Sense	Sense Coil Output
15	+ Bias	Sensor Detector Plus Bias
16	EEPROM Clock	EEPROM Clock
17	Drive	Sensor Drive Coil Input
18	Thermistor	Thermistor Voltage

## 1.5 External connectors

CO<sub>2</sub> connector



Pin	Signal
1	Sense Ground
2	- Bias
3	Ground Return
4	Thermistor
5	Drive Coil
6	+ Bias
7	Ground Return
8	Detector Output
9	+ 5 Volts
10	Source
11	Ground Return
12	Heater
13	Signal Ground
14	- 5 Volts
15	EEPROM Clock
16	Sense Coil
17	EEPROM Data
18	EEPROM CS
19	N/C
20	Ground Return

## **2 SERVICE PROCEDURES**

### **2.1 General service information**

Field service for the CO<sub>2</sub> board is limited to replacement of faulty circuit boards or mechanical parts. The board should be returned to Datex-Ohmeda for repair.

Datex-Ohmeda is always available for service advice. Please provide the monitor serial number, full type designation, and a detailed fault description.

**CAUTION** Only trained personnel with the appropriate tools and equipment should perform the tests and repairs outlined in this section. Unauthorized service may void warranty of the unit.

### **2.2 Service check**

Perform these checks after any service and at least once every six months to keep the monitor in good condition.

#### **2.2.1 Visual inspection**

1. Make sure that the Mainstream Sensor connector is intact.

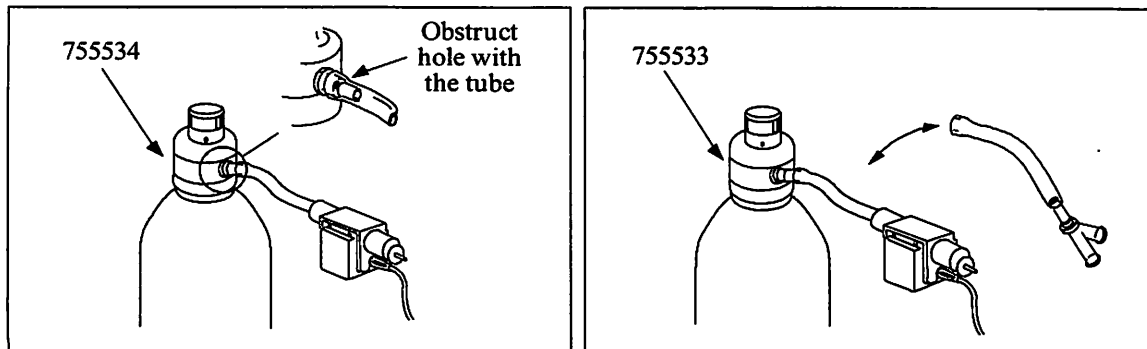
## 2.3 Adjustments and calibrations

### 2.3.1 CO<sub>2</sub> calibration check

Pryon recommends that the CO<sub>2</sub> sensor should be checked at least once annually to ensure its accuracy.

Equipment needed:

- CO<sub>2</sub> Calibration Check Adapter Kit (P/N 902305)
- Calibration Gas 5.00 % CO<sub>2</sub> (P/N 755580)
- Patient Airway Adapter.



When using Datex-Ohmeda calibration gas regulator note the following:

- With regulator P/N 755533 remove the tube with Y-piece. Connect the silicone tube (comes with the adapter) on the nozzle of the regulator.
- With regulator P/N 755534 slide the silicone tube until it blocks also the little hole on the nozzle. This will ensure that the CO<sub>2</sub> concentration rises high enough in the calibration check adapter.

#### To check the mainstream CO<sub>2</sub> sensor

1. Turn the monitor ON.
2. Change the mode of operation to MainSt.
3. Change the CO<sub>2</sub> units of measure to % CO<sub>2</sub>.
4. Fix the mainstream sensor to the patient airway adapter.
5. Let the CO<sub>2</sub> sensor warm up for 15 minutes.
6. At the end of the 15 minute warm-up period, observe the reading of CO<sub>2</sub> in %. The CO<sub>2</sub> reading should be between 0.0 % - 0.3 % with well ventilated room air.
7. Fix the mainstream sensor to the CO<sub>2</sub> calibration airway adapter.
8. Feed 5.00 % CO<sub>2</sub> gas (e.g. Datex-Ohmeda Quick Cal Calibration Gas, order no. 755580) to the free end of the silicon tube (included in the kit P/N 902305). Introduce a steady stream of gas until FiCO<sub>2</sub> and EtCO<sub>2</sub> readings are same and observe the reading. The CO<sub>2</sub> reading should be 5 % ± 0.3 % for a 5 % gas.
9. If the values do not fall within the acceptable ranges, contact your local Datex-Ohmeda distributor for further information.



**Possible causes of error**

1. Calibration should be performed using a CO<sub>2</sub> calibration gas of a known concentration. To validate the concentration of the calibration gas, check by using several different sensors. If they are all consistently high or low, there is a good chance that the gas sample is suspect and another gas source should be tried. Also, make sure all connections are air tight.
2. Performing a calibration check before the sensor is warmed up will cause erroneous CO<sub>2</sub> values. The sensor must be warmed up to 42 °C before a calibration check is performed. Allow 15 minutes for the sensor to warm up and repeat the test.
3. An insufficient gas flow is a possible cause of error. The normal gas flow is 200 ml/min.
4. A dirty or faulty patient airway adapter/CO<sub>2</sub> calibration airway adapter will cause an error in the CO<sub>2</sub> reading. Clean or replace the patient airway/ CO<sub>2</sub> calibration airway adapter.
5. Check all pneumatic tubing and connections for air leaks. Repair as needed.

## 3 SERVICE MENU

### 3.1 CO<sub>2</sub> module menu

**NOTE:** Parameter values in every Data -fields are for reference only.

CO <sub>2</sub>	Service Data
<p>Sensor data </p> <p>Pump data </p> <p>Previous Menu</p>	<p>HW version</p> <p>SW version</p>  <p>pressure (mmHg/10)    7500</p> <p>Status str</p> <p>Timeouts                    0</p> <p>Bad checksums            0</p> <p>Send queue full            0</p>

#### Sensor data

See chapter 3.1.1 Sensor Menu.

#### Pump data

See chapter 3.1.2 Pump Menu.

#### Service data

*HW version*      Hardware version of a CO<sub>2</sub> board.

*SW version*      Software version of a CO<sub>2</sub> board.

#### *pressure (mmHg/10)*

Atmospheric **pressure** measured by a CO<sub>2</sub> board. Default value is 750 mmHg. This value is used for converting values between mmHg and %.

*Status str*      **Status str** tells more specific data concerning alarms.

*Timeouts*      **Timeouts** is a cumulative number that indicates how many times the module has not responded to the monitor's inquiry.

*Bad checksums*    **Bad checksums** is also a cumulative number that indicates how many times communication from the module to monitor broke down.

*Send queue full*    **Send queue full** is a cumulative number that indicates how many communication errors the module has detected.



### 3.1.2 Sensor menu

**NOTE:** Parameter values in every Data -fields are for reference only.

C02	Sensor data	
Previous Menu	sensor	no sensor!
	serial no	-1
	sensor rev.	
	customer code	FFFF
	temperature (C)	0.-2
	last cal date (hex)	
	pressure (mmHg/10)	7500
	Status str	
	Timeouts	0
	Bad checksums	0
	Send queue full	0

#### Sensor data

- sensor*      **Sensor** shows if the sensor is not connected.
- serial no*      **Serial number** of a sensor.
- sensor rev.*      **Sensor rev.** shows a revision of the sensor.
- custom code*      **Custom code** must be 10 with Datex-Ohmeda MS sensor. Sensors by other manufacturers are not possible and generates alarm 'Use Datex-Ohmeda sensor'.
- temperature (C)*      **Temperature** shows the temperature of a sensor (°C). Temperature of a warm-up MS sensor should be 40...42 °C.
- last cal date (hex)*      **Last cal date** shows the latest calibration date of a sensor in hexadecimal mode.
- pressure (mmHg/10)*      Atmospheric **pressure** measured by a CO<sub>2</sub> board. Default value is 750 mmHg. This value is used for converting values between mmHg and %.
- Status str*      **Status str** tells more specific data concerning alarms.
- Timeouts*      **Timeouts** is a cumulative number that indicates how many times the module has not responded to the monitor's inquiry.
- Bad checksums*      **Bad checksums** is also a cumulative number that indicates how many times communication from the module to monitor broke down.
- Send queue full*      **Send queue full** is a cumulative number that indicates how many communication errors the module has detected.

### 3.1.3 Pump menu

**NOTE:** Parameter values in every Data -fields are for reference only.

C02	Pump data
Previous Menu	Flow rate (ml/min)     -1 Pump ctrl value        0
	pressure (mmHg/10)    7500 Status str
	Timeouts                0 Bad checksums         0 Send queue full        0

#### Pump data

*Flow rate (ml/min)*

**Flow rate** shows adjusted flow rate which should be 150 ml/min.

*Pump ctrl value*

**Pump ctrl value** is comparable to supplied power to the pump.

*pressure (mmHg/10)*

Atmospheric **pressure** measured by a CO<sub>2</sub> board. Default value is 7500 mmHg. This value is used for converting values between mmHg and %.

*Status str*

**Status str** tells more specific data concerning alarms.

*Timeouts*

**Timeouts** is a cumulative number that indicates how many times the module has not responded to the monitor's inquiry.

*Bad checksums*

**Bad checksums** is also a cumulative number that indicates how many times communication from the module to monitor broke down.

*Send queue full*

**Send queue full** is a cumulative number that indicates how many communication errors the module has detected.

# ISOLATION POWER SUPPLY UNIT FOR CO<sub>2</sub> UNIT

Datex-Ohmeda, Inc.  
P.O. Box 7550, Madison  
WI 53707-7550, USA  
Tel. +1-608-221-1551  
Fax +1-608-222-9147  
[www.us.datex-ohmeda.com](http://www.us.datex-ohmeda.com)

Datex-Ohmeda Division,  
Instrumentarium Corp.  
P.O. Box 900, FIN-00031  
DATEX-OHMEDA, FINLAND  
Tel. +358 10 39411 Fax +358 9 146 3310  
[www.datex-ohmeda.com](http://www.datex-ohmeda.com)  
© Instrumentarium Corp. All rights reserved.

# TABLE OF CONTENTS

## ISOLATION POWER SUPPLY UNIT FOR CO<sub>2</sub> UNIT

<b>1</b>	<b>FUNCTIONAL DESCRIPTION</b>	<b>1</b>
1.1	General .....	1
1.2	Connectors.....	2
<b>2</b>	<b>SERVICE PROCEDURES</b>	<b>3</b>
2.1	General service information.....	3
<b>3</b>	<b>TROUBLESHOOTING</b>	<b>4</b>
3.1	Troubleshooting flowchart .....	4



# 1 FUNCTIONAL DESCRIPTION

## 1.1 General

The power supply distributes power to CO<sub>2</sub> unit providing 1.5 kV patient isolation.

Input voltage range is 10.0...15.0 V. Output voltage is regulated to 10.0 V  $\pm$ 2.5 %. In the case of malfunction of feedback circuit, output voltage is limited to 11.0 V.

Isolation power supply can be shut down for power saving by the host if CO<sub>2</sub> measurement is not used.

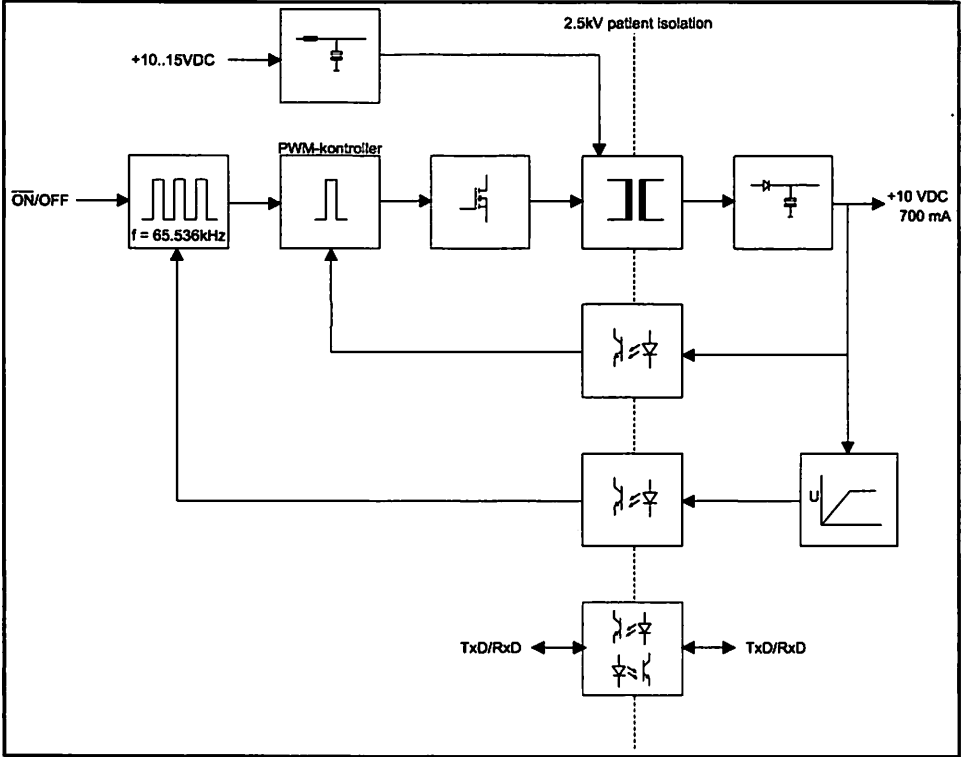


Figure 1 Block diagram of CO<sub>2</sub> isolation supply unit

## 1.2 Connectors

### CO<sub>2</sub> unit connector (X1)

Pin no.	Signal	Description
1	WTPR#	SideStream Water Trap present
2	GNDF	Signal ground
3	GNDF	Signal ground
4	+10V	+10V output voltage
5	TXDF	Data from CO <sub>2</sub> unit (TTL-level)
6	RXDF	Data to CO <sub>2</sub> unit (TTL-level)

### Host connector (X2)

Pin no.	Signal	Description
1	WTP#	SideStream Water Trap present
2	GND	Signal ground
3	GND	Signal ground
4	+12V	+12V input voltage
5	TXD	Data to CO <sub>2</sub> unit (TTL-level)
6	+5V	+5V digital voltage
7	SHD	Shut down
8	RXD	Data from CO <sub>2</sub> unit (TTL-level)

## **2 SERVICE PROCEDURES**

### **2.1 General service information**

Field service for the CO<sub>2</sub> isolation power supply unit is limited to replacing a faulty circuit board. The boards should be returned to Datex-Ohmeda for repair.

Datex-Ohmeda is always available for service advice. Please provide the monitor serial number, full type designation, and a detailed fault description.

**CAUTION** Only trained personnel with the appropriate tools and equipment should perform the tests and repairs outlined in this section. Unauthorized service may void warranty of the unit.



### 3 TROUBLESHOOTING

Before troubleshooting the power supply unit, please refer to the general troubleshooting procedures described in part I.

#### 3.1 Troubleshooting flowchart

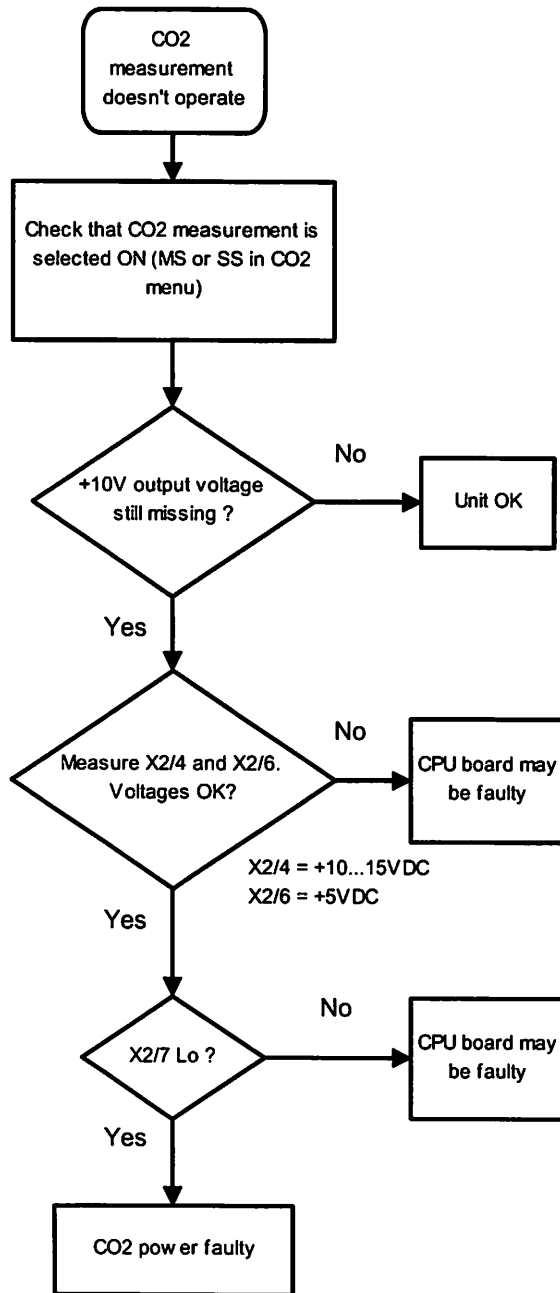


Figure 2 Power supply board troubleshooting flowchart

**Datex-Ohmeda**  
**S/5™ Light Monitor Recorder, N-LREC**  
**Technical Reference Manual**

All specifications are subject to change without notice.

Document No. 890201-5

November 2000

Datex-Ohmeda, Inc.  
P.O. Box 7550, Madison  
WI 53707-7550, USA  
Tel. +1-608-221-1551  
Fax +1-608-222-9147  
[www.us.datex-ohmeda.com](http://www.us.datex-ohmeda.com)

Datex-Ohmeda Division,  
Instrumentarium Corp.  
P.O. Box 900, FIN-00031  
DATEX-OHMEDA, FINLAND  
Tel. +358 10 394 11 Fax +358 9 146 3310  
[www.datex-ohmeda.com](http://www.datex-ohmeda.com)  
© Instrumentarium Corp. All rights reserved.

# TABLE OF CONTENTS

## S/5™ Light Monitor Recorder, N-LREC

<b>TABLE OF CONTENTS</b>	<b>i</b>
<b>1 INTRODUCTION</b>	<b>3</b>
<b>2 SPECIFICATIONS</b>	<b>4</b>
<b>3 FUNCTIONAL DESCRIPTION</b>	<b>5</b>
3.1 General.....	5
3.2 Connectors .....	5
3.2.1 Rec-board connector, X1 .....	5
3.2.2 Rec-board connector, X2.....	6
<b>4 SERVICE PROCEDURES</b>	<b>7</b>
4.1 General service information .....	7
4.2 Preventive maintenance.....	7
4.2.1 Visual inspection .....	7
4.2.2 Functional checks.....	7
4.3 Disassembly and reassembly .....	8
<b>5 TROUBLESHOOTING</b>	<b>9</b>
5.1 Troubleshooting chart.....	9
5.2 Error messages.....	9
<b>6 SERVICE MENU</b>	<b>10</b>



# 1 INTRODUCTION

The built-in recorder module of the S/5 Light Monitor/Light Solo, N-LREC, provide real time printing of waveform and numerical data, and printing up to 12 hours trend data.

NOTE: Printings on thermal paper may be destroyed when exposed to light, heat, alcohol etc. Take a photocopy for the archive.

## 2 SPECIFICATIONS

Principle	Thermal array
Print resolution:	
Vertical	8 dots/mm (200 dots/in)
Horizontal	32 dots/mm (800 dots/in) at speed of 25 mm/s and slower, 16 dots/mm (400 dots/in) at speed of 50 mm/s
Paper width	50 mm
Printing width	48 mm
Traces	Selectable 1, 2 or 3 traces
Print speed	12.5, 25 and 50 mm/s

## 3 FUNCTIONAL DESCRIPTION

### 3.1 General

The recorder board connects the recorder module to CPU-board. The recorder board and the CPU-board are connected together with a 16-pin ribbon cable.

Communication with the host processor on the CPU-board takes place in TTL-level serial communication.

The TTL-level reset signal (RST#) is active when either the host reset or host power-up reset is active.

### 3.2 Connectors

#### 3.2.1 Rec-board connector, X1

Pin	I/O	Signal
1	0	SYNC#
2	-	Ground
3	1	RST#
4	1	RXD
5	-	Ground
6	0	TXD
7	0	CTS#
8	-	Ground
9	1	RTS#
10	-	+ 5 VDC
11	-	Ground
12	-	+12 VN
13	-	+12 VN
14	-	+12 VN
15	-	+12 VN
16	-	Ground

3.2.2 Rec-board connector, X2

Pin	I/O	Signal	Pin	I/O	Signal
A1	-	N/C	B1	-	N/C
A2	0	TXD	B2	-	N/C
A3	-	N/C	B3	-	N/C
A4	-	N/C	B4	-	+5 VC
A5	-	N/C	B5	-	+5 VC
A6	-	N/C	B6	-	Ground
A7	-	N/C	B7	-	Ground
A8	-	N/C	B8	-	Ground
A9	-	N/C	B9	-	Ground
A10	1	RXD	B10	-	Ground
A11	0	CTS#	B11	-	Ground
A12	-	N/C	B12	-	Ground
A13	1	RST#	B13	-	Ground
A14	-	N/C	B14	-	Ground
A15	-	N/C	B15	-	Ground
A16	0	SYNC# *	B16	-	Ground
A17	-	N/C	B17	-	Ground
A18	1	RTS#	B18	-	+12 VN
A19	-	N/C	B19	-	+12 VN
A20	-	N/C	B20	-	+12 VN
A21	-	N/C	B21	-	+12 VN
A22	-	N/C	B22	-	+12 VN
A23	-	N/C	B23	-	+12 VN
A24	-	N/C	B24	-	+12 VN
A25	-	N/C	B25	-	+12 VN

\* Not used



---

## 4 SERVICE PROCEDURES

### 4.1 General service information

Field service for the recorder is limited to replacing a faulty circuit board or mechanical parts. Return the board to Datex-Ohmeda for repair.

Datex-Ohmeda is always available for service advice. Please provide the unit serial number, full type designation, and detailed fault description.

**CAUTION** Only trained personnel with appropriate equipment should perform the tests and repairs outlined in this section. Unauthorized service may void warranty of unit.

### 4.2 Preventive maintenance

Perform these checks after any service and at least once every sixth months to keep the recorder in good condition.

#### 4.2.1 Visual inspection

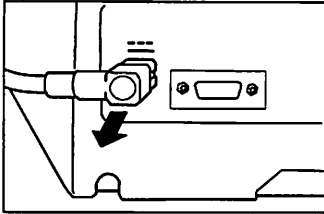
If the monitor housing is open, check that the recorder board is not loose and that the ribbon cable is properly attached.

#### 4.2.2 Functional checks

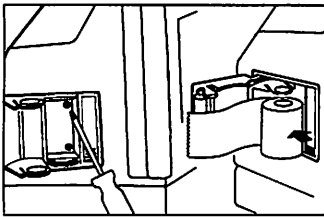
1. Insert the recorder into the monitor. Turn the power on. No error message appears.
2. Check the functions of the Start/Stop key on the recorder.
3. Press the **Menu** key. Enter **Recorder - Recorder Setup**. Choose 6.25 mm/s as paper speed and 30 seconds as recording length. Start printing. The length of the printout should be  $18.5 \pm 1$  cm.
4. Change paper speed to 12.5 mm/s. The length should be  $37.5 \pm 3$  cm.
5. Change paper speed to 25 mm/s. The length should be  $75 \pm 6$  cm.
6. Press the **Menu** key. Enter **Recorder - Recorder Setup - Wave Setup**. Choose the following waveforms to be recorded:  
Waveform 1  $\Rightarrow$  ECG  
Waveform 2  $\Rightarrow$  OFF  
Waveform 3  $\Rightarrow$  OFF
7. Press the Start/ Stop key on the recorder. The printout should fill the paper and lines should be unbroken.

### 4.3 Disassembly and reassembly

**Disassemble the recorder according to the following procedure.**



Turn the monitor off and remove the power adapter cable.



Install the recorder and tighten the screws on the back wall of the paper slot. Insert the paper roll and close the recorder cover.

Perform functional checks described in chapter 4.2.

## 5 TROUBLESHOOTING

### 5.1 Troubleshooting chart

TROUBLE	CAUSE	TREATMENT
Recorder will not start.  No error messages shown.	Recorder board ribbon cable broken.  Recorder board loose.  Recorder faulty.	Check the cable. Replace if necessary.  Check recorder board connections.  Replace the recorder.
Recorder works but nothing appears on the paper.	Active side of paper downwards.*  Recorder faulty.	Turn the paper roll.  Replace the recorder.

\* To test which side is active: Place the paper on a hard surface and draw a line with a finger nail. On the active (thermal) side appears a dark line.

### 5.2 Error messages

MESSAGE	EXPLANATION
Recorder: out of paper	Release paper jam or insert a roll of paper into the recorder.
Recorder: cover open	Close the recorder cover correctly.
Recorder: thermal array overheat	Recorder overheated. Stop using and cool it down.
Recorder: input voltage low	+ 12 VN is too low. Check recorder board ribbon cable.
Recorder: input voltage high	+ 12 VN is too high.
Recorder system error 1, 2, 3	System error. Remove recorder and reinsert it.
Recorder: module removed	Insert the recorder properly.

## 6 SERVICE MENU

There is no service menu available for the recorder.

**Datex-Ohmeda**

**S/5 Light Monitor  
Light Solo**

**POWER ADAPTER, N-LPOW  
POWER ADAPTER FOR TRANSPORT VEHICLES, N-LPOWT**

**Technical Reference Manual**

All specifications are subject to change without notice.

Document No. 890202-5

November 2000

Datex-Ohmeda, Inc.  
P.O. Box 7550, Madison  
WI 53707-7550, USA  
Tel. +1-608-221-1551  
Fax +1-608-222-9147  
[www.us.datex-ohmeda.com](http://www.us.datex-ohmeda.com)

Datex-Ohmeda Division,  
Instrumentarium Corp.  
P.O. Box 900, FIN-00031  
DATEX-OHMEDA, FINLAND  
Tel. +358 10 39411 Fax +358 9 146 3310  
[www.datex-ohmeda.com](http://www.datex-ohmeda.com)  
© Instrumentarium Corp. All rights reserved.

## TABLE OF CONTENTS

### POWER ADAPTER, N-LPOW AND POWER ADAPTER FOR TRANSPORT VEHICLES, N-LPOWT

<b>1</b>	<b>INTRODUCTION</b>	<b>1</b>
1.1	N-LPOW .....	1
1.2	N-LPOWT .....	1
<b>2</b>	<b>SPECIFICATIONS</b>	<b>2</b>
2.1	N-LPOW .....	2
2.2	N-LPOWT .....	2
<b>3</b>	<b>FUNCTIONAL DESCRIPTION</b>	<b>3</b>
3.1	General .....	3
3.1.1	N-LPOW .....	3
3.2	Connectors .....	3
3.2.1	N-LPOW .....	3
<b>4</b>	<b>SERVICE PROCEDURES</b>	<b>4</b>
4.1	General service information .....	4
4.1.1	N-LPOW .....	4
4.1.2	N-LPOWT .....	4
4.2	Disassembly and reassembly .....	4
4.2.1	N-LPOW .....	4
4.2.2	Changing output cable .....	5
4.3	Installation .....	6
4.3.1	N-LPOWT .....	6
4.4	Operation .....	7
4.4.1	N-LPOWT .....	7
<b>5</b>	<b>TROUBLESHOOTING</b>	<b>8</b>
5.1	Troubleshooting chart .....	8
5.1.1	N-LPOW .....	8
<b>6</b>	<b>SERVICE MENU</b>	<b>9</b>

## TABLE OF FIGURES

Figure 1	Power adapter .....	3
Figure 2	Opening the power adapter .....	5
Figure 3	Output cable location .....	6
Figure 4	Adapter attachment .....	6
Figure 5	Attaching the input connector socket .....	7



# 1 INTRODUCTION

## 1.1 N-LPOW

The Datex-Ohmeda Light Monitor Power Adapter, **N-LPOW** is an AC/DC converter for converting the mains voltage from the 220-240/100-120 Vac to voltages used by the monitor +12.5/+18.5 Vdc.



NOTE: Before use check that the voltage range is selected properly.

The voltage selection switch has two positions:

Window shows	Voltage range in use
115 V	110 - 120 V
230 V	220 - 240 V

## 1.2 N-LPOWT

The Datex-Ohmeda Light Monitor Power Adapter for Transport Vehicles, **N-LPOWT**, is designed to provide the Light Monitor with electric power in medical transport vehicle environment and ensure battery charging.



NOTE: For indoor use only. Do not immerse in liquid or allow any liquid to enter the adapter.



## 2 SPECIFICATIONS

### 2.1 N-LPOW

Dimensions (W × D × H)	115 × 175 × 55 mm / 4.5 × 6.9 × 2.2"
Weight	0.9 kg
AC voltage range and frequencies	220-240/100-120 V~, 50/60 Hz
Allowed AC voltage fluctuations	100 V -10 %...120 V +10 % 220 V -10 %...240 V +10 %
DC voltage	12.5 Vdc and 18.5 Vdc
Protection class	Class I
Safety standards	IEC 601-1, CSA 2601-1
Grounding	Hospital grade

### 2.2 N-LPOWT

Dimensions (W × D × H)	220 × 115 × 54 mm / 8.5 × 4.5 × 2.1"
Weight	1.1 kg
Input voltage range and fluctuations	12 Vdc -15 %...32 Vdc +10 %
Output voltage	12.5 Vdc, 3.0 A and 18.5 Vdc, 0.6 A
Battery charging time	typical 3.5 h/batt (13.2 V 1.8 Ah)
Power consumption	65 W max.
Operating temperature	±0...+40 °C (32...104 °F)
Battery charging temperature	+10...+40 °C (50...104 °F)
Storage and transport temperature	-30...+70 °C (14...122 °F)
Relative humidity	5...95 %, non-condensing
Safety standards	IEC 601-1
IP class	IPX1

## 3 FUNCTIONAL DESCRIPTION

### 3.1 General

#### 3.1.1 N-LPOW

The power adapter is a AC/DC converter which converts the mains voltage to +12.5 Vdc and +18.5 Vdc. +18.5 Vdc is 600 mA constant current source for battery charging.

The green LED in the secondary end indicates whether the power adapter is energized.

Chassis and secondary ground are connected to the protective earth (PE).

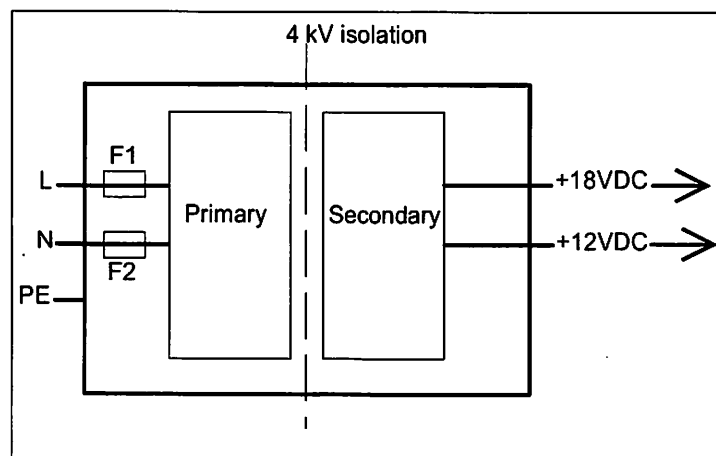
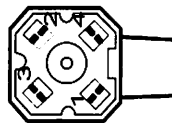


Figure 1 Power adapter

### 3.2 Connectors

#### 3.2.1 N-LPOW

##### Secondary cord



Pin	Signal
1	12V
2	GND
3	18V
4	GND

## 4 SERVICE PROCEDURES

### 4.1 General service information

Datex-Ohmeda is always available for service advice. Please provide the unit serial number, full type designation, and detailed fault description.

**CAUTION** Only trained personnel with appropriate equipment should perform the tests and repairs outlined in this section. Unauthorized service may void warranty of the unit.

#### 4.1.1 N-LPOW

Field service for the power adapter is limited to replacing fuses. Faulty power adapters should be returned to Datex-Ohmeda for repair.

#### 4.1.2 N-LPOWT

Do not open the device. In case of failure, send the adapter back to manufacturer's technical service through your local distributor.

### 4.2 Disassembly and reassembly

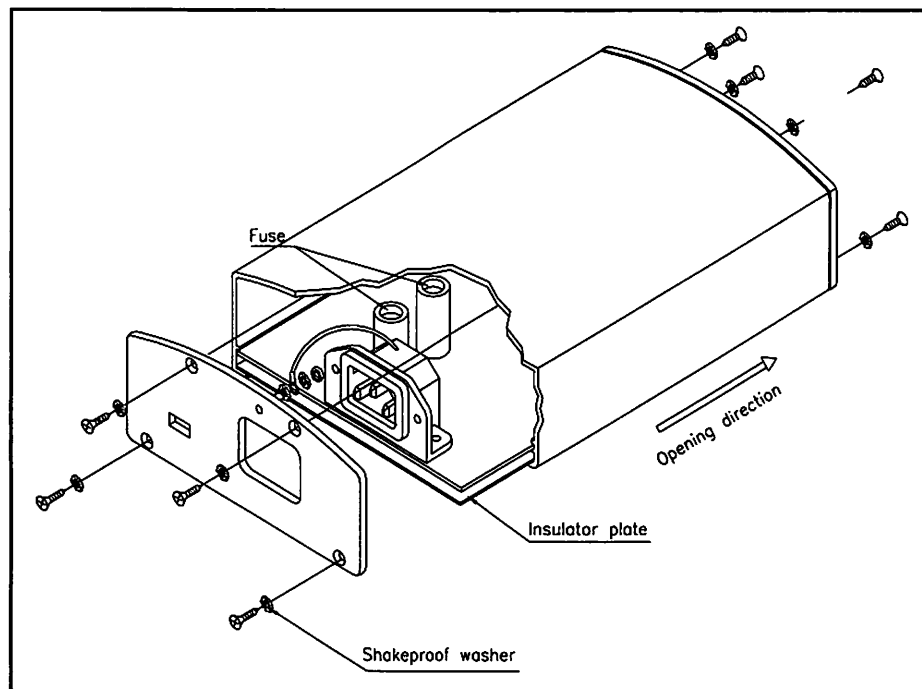
#### 4.2.1 N-LPOW

Only open the frame to exchange fuses or output cable, other service procedures are not allowed. Refer to figure 2.

1. Remove the four screws from the primary end of the power adapter.
2. Remove the grounding wire attached to the cover plate.
3. Remove the four screws from the secondary end of the power adapter.
4. Pull out the main PCB. Fuses are located inside the fuse holders located near by the power inlet.

When reassembling the power adapter, make sure that the plastic insulator is properly in its place between the solder side of the PC board and the frame.

**NOTE:** Replace shakeproof washers in order to maintain appropriate enclosure grounding.



**Figure 2**      **Opening the power adapter**

#### **4.2.2 Changing output cable**

1.    Disassemble the frame as described in previous chapter.
2.    Remove the solderings (if cable is soldered to PCA) of the old cable and release the strain relief from end plate.
3.    Solder PCA connector which came with new cable to the PCA as shown in figure 3.
4.    Place new cable and strain relief on its position on end plate and connect cable connector to the PCA connector.
5.    Reassemble the frame as described in previous chapter and test that monitor works and charges batteries with power adapter.

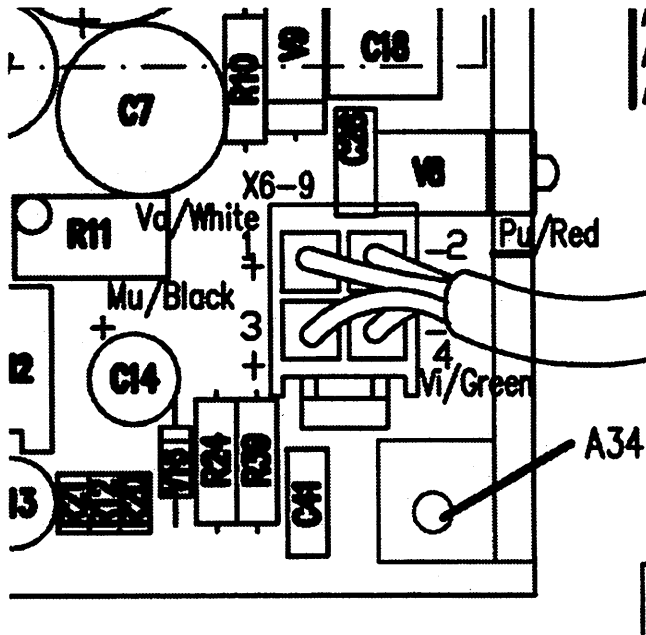


Figure 3 Output cable location

## 4.3 Installation

### 4.3.1 N-LPOWT

Power adapter can be positioned in any position except upside down. Attach the adapter firmly to the structure of the transport vehicle using e.g. screws (figure 3).

Do not cover the adapter so that heat transfer is prevented, and do not allow the adapter hang on it's cables only.

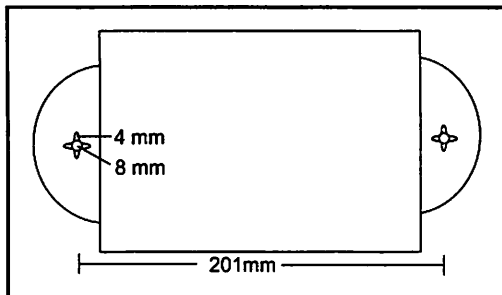
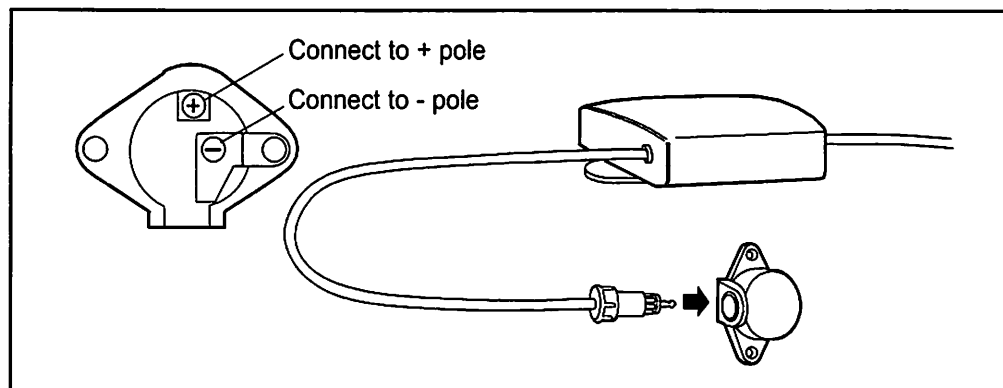


Figure 4 Adapter attachment

Connect the power adapter to the monitor's rear panel connector with the output cable, and to the medical transport vehicle's electrical outlet connector with the input cable. The output cable is 2.0 m (6.5 ft), and the connector on the monitor side is a four pole cable socket with moulded-on lead (similar to that of Light Monitor Power Adapter, N-LPOW). The input cable is 1.5 m (4.9 ft) and equipped with a DIN ISO 4165 plug. The package includes the input connector socket, which can be installed into the transport vehicle (figure 4).



**Figure 5 Attaching the input connector socket**

## 4.4 Operation

### 4.4.1 N-LPOWT

Input voltage range is +12...+32 VDC. The adapter has two DC-outputs; 12.5 V / 3.0 A and 18.5 V / 0.60 A. Both outputs are pre-adjusted, no further adjustments can be done.

To measure output voltages (outputs are not loaded):

1. Plug the input connector in the socket
2. Measure with a multimeter the output voltage 1 from the pins 1 and 4 - ( $12.5 \pm 0.1$  V)
3. Measure with a multimeter the output voltage 2 from the pins 3 and 2 - ( $18.5 \pm 0.2$  V)

To verify that the adapter is connected to the electrical power system, check that the green light is lit in the external power indicator on the monitor.

To verify that the adapter is charging the batteries, check that a charging message is displayed in battery status indicator on the monitor screen, and that the battery charge status LED (I or II) is flashing on the battery module.

To ensure the proper operation, use the power adapter at least once a year for 30 min.

**CAUTION** Do not attach the input cable to mains socket.

**CAUTION** Do not open the device. In case of failure, send the adapter back to manufacturer's technical service through your local distributor.

In case another type of input connector is preferred:

Ensure that the current specifications of the connector permit the maximal current (maximum power consumption divided by the voltage from your vehicle). In the internal cable wiring the brown wire equals to the positive line, and the blue wire to the negative line.

## 5 TROUBLESHOOTING

### 5.1 Troubleshooting chart

#### 5.1.1 N-LPOW

<b>TROUBLE</b>	<b>CAUSE</b>	<b>TREATMENT</b>
Green LED is off	Mains not connected	Check power cord
Green LED is off	Blown fuse	Check fuses

## 6 SERVICE MENU

There is no service menu available for the power adapter.





**Datex-Ohmeda**  
**S/5 Light Monitor**  
**Light Solo**

**BATTERY MODULE, F-LBAT**  
**Technical Reference Manual**

All specifications are subject to change without notice.

Document No. 890200-5

November 2000

Datex-Ohmeda, Inc.  
P.O. Box 7550, Madison  
WI 53707-7550, USA  
Tel. +1-608-221-1551  
Fax +1-608-222-9147  
[www.us.datex-ohmeda.com](http://www.us.datex-ohmeda.com)

Datex-Ohmeda Division,  
Instrumentarium Corp.  
P.O. Box 900, FIN-00031  
DATEX-OHMEDA, FINLAND  
Tel. +358 10 394 11 Fax +358 9 146 3310  
[www.datex-ohmeda.com](http://www.datex-ohmeda.com)  
© Instrumentarium Corp. All rights reserved.

---

# TABLE OF CONTENTS

## BATTERY MODULE, F-LBAT

<b>TABLE OF CONTENTS</b>	<b>i</b>
<b>1 INTRODUCTION</b>	<b>3</b>
<b>2 SPECIFICATIONS</b>	<b>4</b>
2.1 Battery module .....	4
2.2 Battery .....	4
<b>3 FUNCTIONAL DESCRIPTION</b>	<b>5</b>
3.1 General .....	5
3.2 Connectors .....	6
3.2.1 Battery module connector.....	6
3.2.2 Battery connector .....	6
<b>4 SERVICE PROCEDURES</b>	<b>7</b>
4.1 General service information .....	7
4.2 Preventive maintenance.....	7
4.3 Installing the battery module .....	8
<b>5 TROUBLESHOOTING</b>	<b>10</b>
5.1 Troubleshooting chart.....	10
5.2 Messages.....	10
5.3 Battery error messages on Light Solo .....	11
5.4 Battery error messages on Light Monitor .....	13
<b>6 SERVICE MENU</b>	<b>14</b>



# 1 INTRODUCTION

The Battery Module, F-LBAT can be used with S/5 Light Monitor and Light Solo monitors. F-LBAT includes two rechargeable batteries. The batteries can easily be removed and replaced.

## 2 SPECIFICATIONS

### 2.1 Battery module

Dimensions (W × D × H)	290 × 150 × 40 mm / 11.5 × 5.9 × 1.6"
Weight	0.5 kg (without batteries)

### 2.2 Battery

Related to p/n 887753.	
Dimensions (W × D × H)	58 × 278 × 32 mm / 1.1 × 10.9 × 1.2"
Weight	0.7 kg
Type	NiCd
Charging time	3.5 hours for each battery
Nominal voltage	13.2 V
Capacity	1.8 Ah

## 3 FUNCTIONAL DESCRIPTION

### 3.1 General

The batteries are located in a battery module. The batteries can be inserted in the battery module from the left side of the monitor. The battery module is designed for two batteries.

When the monitor is battery driven with two batteries, one battery is always discharged first. Less charged battery is discharged first.

The batteries are charged with a constant current limited by external power supply.

A battery has a non-volatile memory for capacity meter, ID status and fault information.

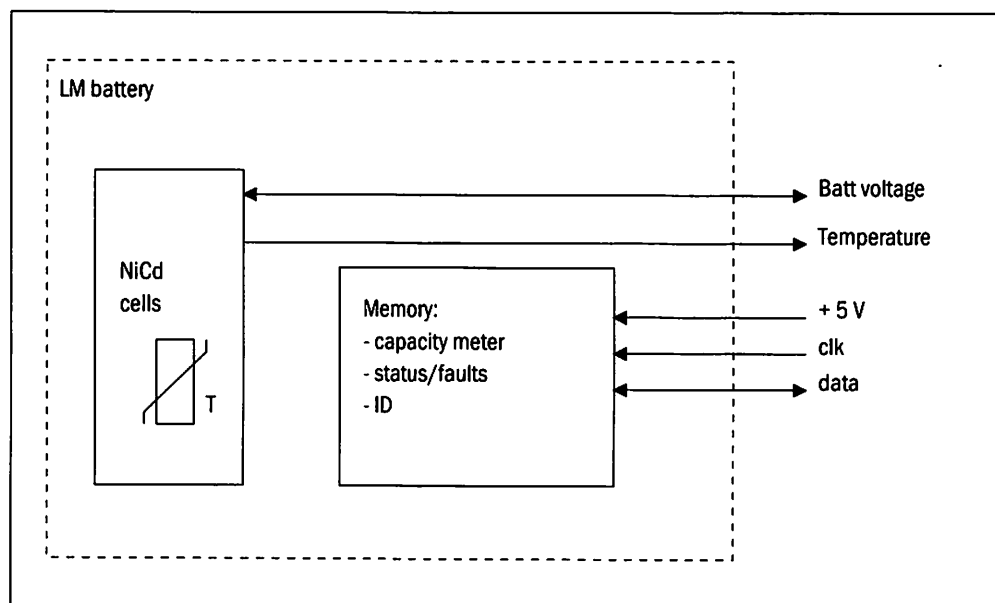


Figure 1 Battery block diagram

## 3.2 Connectors

### 3.2.1 Battery module connector

Pin	I/O	Signal	Function
1	0	B1TEMP	Battery #1 temperature
2	0	B1PRESS#	Battery #1 present
3	-	GND	Ground
4	I/O	PDATA	Battery bus, data
5	I	B1LED	Battery #1 charge led drive
6	-	+ 5 VC	+5 V monitor voltage
7	-	GND	Ground
8	-	UB1	Battery #1 voltage
9	-	UB1	Battery #1 voltage
10	-	GND	Ground
11	-	GND	Ground
12	-	UB2	Battery #2 voltage
13	-	UB2	Battery #2 voltage
14	0	B2TEMP	Battery #2 temperature
15	0	B2PRESS#	Battery #2 present
16	-	GND	Ground
17	I	PCLK	Battery bus, clock
18	I	B2LED	Battery #2 charge led drive
19	-	GND	Ground
20	-	UB1	Battery #1 voltage
21	-	UB1	Battery #1 voltage
22	-	GND	Ground
23	-	GND	Ground
24	-	UB2	Battery #2 voltage
25	-	UB2	Battery #2 voltage

### 3.2.2 Battery connector

Pin	I/O	Signal	Function
1	-	+ 12 V	Battery voltage
2	-	GND	Ground
3	I/O	PDATA	Battery bus, data
4	I	ADDR	Battery bus, address
5	I	PCLK	Battery bus, clock
6	0	PRES#	Battery present
7	0	TEMP	Battery temperature
8	-	+ 5 VC	+5 V module voltage



## 4 SERVICE PROCEDURES

### 4.1 General service information

Field service for the battery module is limited to replacing a faulty module. The module should be returned to Datex-Ohmeda for repair.

Datex-Ohmeda is always available for service advice. Please provide the unit serial number, full type designation, and detailed fault description.

**CAUTION** Only trained personnel with appropriate equipment should perform the tests and repairs outlined in this section. Unauthorized service may void warranty of the unit.

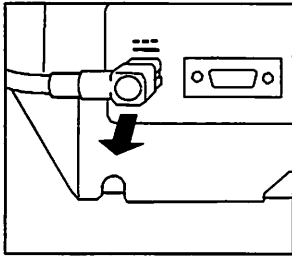
### 4.2 Preventive maintenance

If the monitor is used mostly with mains power, charge and discharge the battery completely two times every three months according to the following procedure.

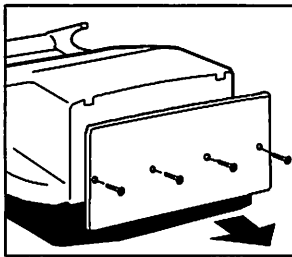
1. Plug in the monitor and wait until both charge LEDs lit.
2. Unplug the monitor and let the monitor run until it shuts down.
3. Repeat step 1 to recharge the battery.

### 4.3 Installing the battery module

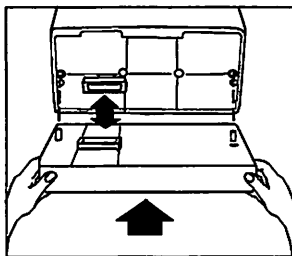
Install the battery module according to the following procedure.



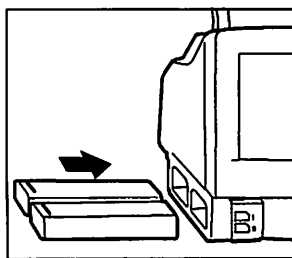
Turn the monitor off and remove the power adapter.



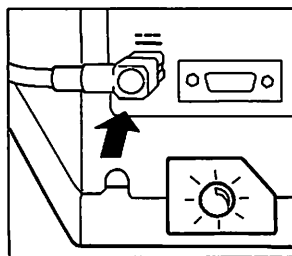
Place the monitor front side down on the table, use soft material between the table and the monitor. Loosen the four screws in the bottom plate of the monitor and pull the plate out of the monitor.



Place empty module frame under the monitor so that the D - connectors match. Tighten the four screws and lift the monitor up to the normal position.

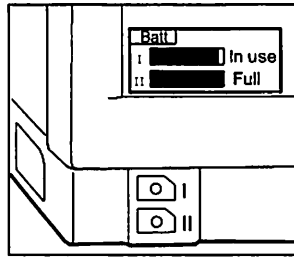


Insert the batteries into the battery slots in the battery frame.



Connect the monitor to the mains power. Verify that one of the battery charge status LEDs is blinking or both LEDs are continuously lit.

**On Light Solo**



Turn the monitor on. Wait for three minutes. Verify that the battery status is displayed and no error messages appear. Disconnect the monitor from the mains power and verify that the monitor operates with both batteries. To do this, test one battery at a time.

**On Light Monitor**



**Figure A Operating**



**Figure B Charging**

Charge the batteries full before using the monitor.

## 5 TROUBLESHOOTING

### 5.1 Troubleshooting chart

TROUBLE	CAUSE	TREATMENT
Monitor will not start with batteries.	Batteries are empty.	Charge batteries or replace them with full batteries.
Batt Fault error. See error messages.	Battery Module not properly assembled. Battery not properly inserted in its slot. Battery Module faulty. Battery faulty. Battery +12 V and ground terminals shorted.	Reassemble module properly. Reinsert battery properly. Replace Battery Module. Replace battery. Overcurrent protection triggered. Wait 1-2 hours for reset.
Battery run time shortened.	Monitor is used mainly with external power supply and battery capacity is decreased.	Discharge and recharge battery. See preventive maintenance.

### 5.2 Messages

MESSAGE	EXPLANATION
Batt Low	Less than 10 min of battery time left.
Batt I/II Removed	Battery from slot I/II has been removed.
Discharge battery changed	Monitor switches from one battery to the other because 1) the other is fully discharged or 2) the other is removed (if used).
Charging	Battery is being charged.
Charging discont.	Cooling or warming. Wait until battery has reached suitable temperature. Charge batteries preferably in +10...+35 °C (50...95 °F). If situation persists, power adapter may be faulty.
Empty	Batteries entirely discharged. Connect monitor to power supply to charge batteries. 30 minutes of continuous charging time is minimal requirement to remove empty message.
Full	Batteries fully charged.

### 5.3 Battery error messages on Light Solo

**Table 1** Battery errors, error codes on display and in service view

<b>BCOM</b>	<b>BDATA</b>	<b>TEMPFLT</b>	<b>CELLFLT</b>	<b>Error n (on display)</b>	<b>Service Page</b>
-	-	-	-	-	0h
-	-	-	X	1	1h
-	-	X	-	4	4h
-	-	X	X	5	5h
-	X	-	-	8	8h
-	X	-	X	9	9h
-	X	X	-	12	Ch
-	X	X	X	13	Dh
X	-	-	-	16	10h
X	-	-	X	17	11h
X	-	X	-	20	14h
X	-	X	X	21	15h
X	X	-	-	24	18h
X	X	-	X	25	19h
X	X	X	-	28	1Ch
X	X	X	X	29	1Dh

**Table 2 Setting and resetting the error bits**

<b>Error bit</b>	<b>Description</b>	<b>Setting the bit</b>	<b>Resetting the bit</b>
BCOM	Communication between battery and monitor is lost.	The bit is set if reading the test byte from the battery is not successful (test is done when installing the battery pack into the slot and during recharge initialisation).	If test byte read is successful.
BDATA	Data in the battery pack memory was corrupted and the battery memory has been initialised by factory defaults.	This bit will be not set.	If during recharge initialisation is noticed that the battery has been completely discharged and the latest recharge has been completed and been successful (slope detected as a sign of completed recharge).
TEMPFLT	Temperature measurement of the battery pack is inoperative.	If the temperature measurement result is not within specified limits (poor contact, no contact or short circuit on the battery pack). The check is done like in BCOM and CELLFLT.	If battery temperature is within limits: -30 °C < T < +70 °C.  (Note in the Service View: -300 < T < +700).
CELLFLT	Low voltage over the battery pack.	Battery voltage is below 10 V. The check is done like in BCOM and TEMPFLT.	If battery voltage is over 10 V.

If error bits are set one at a time without any other bit being set (Table 1, bold text):

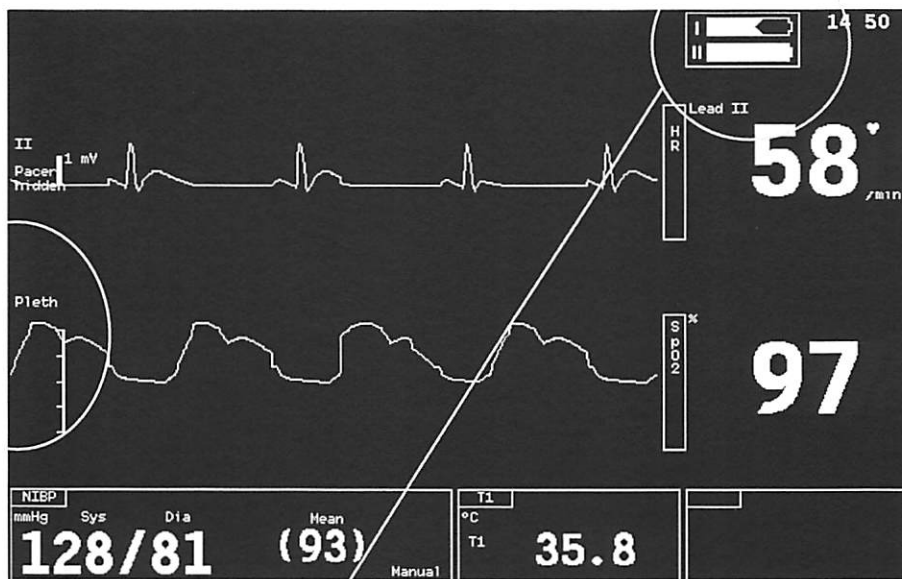
- BCOM: either poor contact in the battery module or battery memory failure. Try in another battery slot.
- BDATA: Normally this does not appear alone. This will be reset after following procedure: Recharge the battery to full, discharge completely empty and start recharging again.
- TEMPFLT: either poor contact inside the battery module or a real temperature failure (Temperature out of specifications). Try in another battery slot.
- CELLFLT: either poor contact inside the battery module or failure on single/multiple battery cell. Try in another battery slot. Monitor uses trickle charge for refreshing the battery. Fault is cleared during recharge initialisation if voltage has arisen above 10 V.

Probably the most common error message is "Error 29" which means that all the possible failures on the battery have been. This is commonly a problem with the contacts inside the battery module. All the battery information is stored in the battery memory inside the battery pack and is read upon main CPUs request. Contact failure can be checked in the Service view: if Status = FFh, Faults = 1Dh, capacities are 24570 and charge/discharge cycles are 16383, it is clearly due to poor contact.

One faulty battery pack can stock still the whole battery bus. In that case all the battery data is on

logical "0" or "1". That is why the batteries should be checked one battery in the module at a time. During Error 29 the battery window on the display is empty followed by ?-mark.

### 5.4 Battery error messages on Light Monitor



See explanation from Power Supply Unit (Part II/slot 2), 4 Service Menu, 4.1 Power Menu, Power Service.

## 6 SERVICE MENU

Please refer to the service menu for the "Power supply unit", in part II, the slot 2.



**Datex-Ohmeda**

**S/5 Light Monitor  
Light Solo**

**LIGHT EXTERNAL BATTERY CHARGER, N-LCHGR**

**Technical Reference Manual**

All specifications are subject to change without notice.

Document No. 896192-1

November 2000

Datex-Ohmeda, Inc.  
P.O. Box 7550, Madison  
WI 53707-7550, USA  
Tel. +1-608-221-1551  
Fax +1-608-222-9147  
[www.us.datex-ohmeda.com](http://www.us.datex-ohmeda.com)

Datex-Ohmeda Division,  
Instrumentarium Corp.  
P.O. Box 900, FIN-00031  
DATEX-OHMEDA, FINLAND  
Tel. +358 10 394 11 Fax +358 9 146 3310  
[www.datex-ohmeda.com](http://www.datex-ohmeda.com)  
© Instrumentarium Corp. All rights reserved.

### **Intended purpose**

Battery Charger is intended for stationary indoor use. Charger is intended for charging the S/5 Light Monitor and Light Solo monitors' batteries only.

### **Classification according to IEC 60601-1**

- CLASS I EQUIPMENT according to the type of protection against electrical shock.
- EQUIPMENT not suitable for use in the presence of a FLAMMABLE ANAESTHETIC MIXTURE with air or with oxygen or nitrous oxide.
- CONTINUOUS OPERATION according to the mode of operation.
- Degree of protection against harmful ingress of water as detailed in the IEC 60529: IPX0, ordinary equipment.

### **Classification according to EU Medical Device Directive**

- The monitor is classified as IIb.

### **Responsibility of the Manufacturer**

Instrumentarium Corp. is responsible for the effects on safety, reliability and performance of the equipment only if:

- assembly, operations, extensions, readjustments, modifications, service and repairs are carried out by authorised personnel.
- the electrical installation of the relevant room complies with appropriate requirements.
- the equipment is serviced, maintained, and used in accordance with this manual.

---

# TABLE OF CONTENTS

## LIGHT EXTERNAL BATTERY CHARGER

<b>TABLE OF CONTENTS</b>	<b>i</b>
<b>1 INTRODUCTION</b>	<b>1</b>
1.1 Related documents .....	1
1.2 Symbols .....	1
1.2.1 Symbols on the charger .....	1
1.2.2 Symbols on the battery .....	2
<b>2 TECHNICAL SPECIFICATIONS</b>	<b>3</b>
2.1 Environmental specifications .....	3
2.2 Electrical specifications .....	3
2.3 Mechanical specifications .....	3
2.4 Battery specifications .....	3
<b>3 FUNCTIONAL DESCRIPTION</b>	<b>4</b>
3.1 General .....	4
3.2 Parts of the charger .....	4
3.3 Charging .....	5
3.3.1 General .....	5
3.3.2 Charge initialization .....	5
3.3.3 Discharging .....	5
<b>4 SERVICE PROCEDURES</b>	<b>6</b>
4.1 General service information .....	6
4.2 Disassembly and reassembly .....	6
4.3 Installation .....	6
4.4 Operation .....	6
<b>5 TROUBLESHOOTING</b>	<b>7</b>
<b>6 SERVICE MENU</b>	<b>8</b>
<b>7 SPARE PARTS</b>	<b>8</b>
7.1 Light external battery charger, N-LCHGR (revision 00 and 01) .....	8
7.2 Exploded view .....	9



# 1 INTRODUCTION

This manual provides technical description and instructions for the service, maintenance and troubleshooting for the Datex-Ohmeda Light External Battery Charger.

## 1.1 Related documents

The *User's Reference Manual* (p/n 896133) advises you on how to use and maintain the Datex-Ohmeda Light External Battery Charger.

## 1.2 Symbols

### 1.2.1 Symbols on the charger



Attention, consult accompanying documents.

flashing symbol on the panel indicates warning:

Error indicator, refer to chapter "Troubleshooting" later in this manual.

on the rear panel indicates the warnings:

For indoor use only.  
 Electric shock hazard. Do not open the charger. Refer servicing to qualified personnel.  
 Disconnect from the mains power and remove both batteries before servicing and cleaning.  
 Do not immerse in liquid or allow any liquid to enter the interior.  
 Check rear panel dust filter regularly, and clean at least once a month.

on the battery unit indicates the warnings and cautions:

Sealed NiCd battery must be recycled or disposed of properly. Discharge before disposing.

### 1.2.2 Symbols on the battery



Attention, consult accompanying documents:

Do not expose to fire.

Do not short-circuit any terminals.

Do not disassemble or mutilate.

Use only with the Light Monitor Battery Module or Light External Battery Charger.

Discharge and charge batteries fully in every 3 months to restore full capacity.



Ni-Cd

Battery packs contain heavy metal cadmium (chemical symbol Cd) and in case of disposal, must be separated from other waste according to local regulations.



Ni-Cd

Battery packs contain Ni-Cd and they can be recycled.

## 2 TECHNICAL SPECIFICATIONS

### 2.1 Environmental specifications

Operating temperature	0...+ 40 °C (+ 32...+ 104 °F)
Charging temperature	+ 10...+ 40 °C (+ 50...+ 104 °F)
Transport and storage temperature	- 30...+ 60 °C (- 22...+ 140 °F), - 30 ...+ 50 °C (- 22...+ 122 °F) for batteries
Humidity	5...95 %, non-condensing

### 2.2 Electrical specifications

Mains voltage	100...240 VAC
Max input power	90 VA
Mains frequency	50...60 Hz
Charge current	1.7 A, $\pm 10$ %
Discharge current	0.6 A, $\pm 10$ %
Typical charging time	1 h per battery / 1.8 Ah
Fuses	2 $\times$ T2AH/250 V, 5 $\times$ 20 mm (p/n 511200), letter H stands for high breaking capacity.

### 2.3 Mechanical specifications

Weight	2.0 kg without batteries
Size (W $\times$ D $\times$ H)	150 $\times$ 295 $\times$ 100 mm (5.9 $\times$ 11.6 $\times$ 3.9 inch)
Material	ABS+PC, Al

### 2.4 Battery specifications

The charger is designed to charge the batteries for S/5 Light Monitor and Light Solo monitors only. Do not use any other batteries.

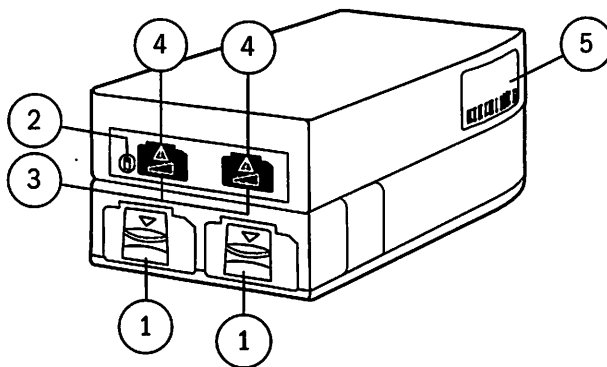
## 3 FUNCTIONAL DESCRIPTION

### 3.1 General

The device is an external charger for the LM Battery. Charger uses discharge-before-charge procedure in order to refresh a battery to its full capacity. The typical charge time is about 1 h for an 1800 mAh battery. There are two battery status indicators of five LED steps indicating the remaining capacity of the battery. Bar also indicates whether a battery is being discharged or recharged. Fault situations are indicated by red LEDs.

Charger can be used with the 100...240 VAC mains voltages (50...60 Hz). There is a green LED indicating that the charger is energized and ready to operate.

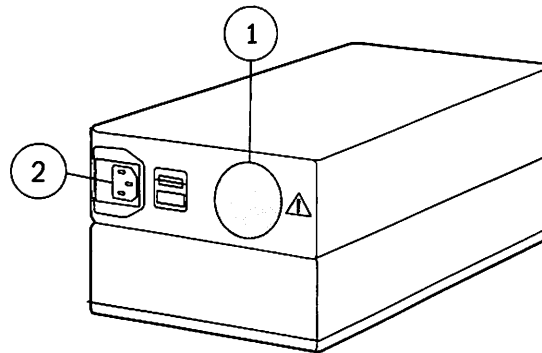
### 3.2 Parts of the charger



**Figure 1** Front panel

- (1) Battery slots
- (2) Power ON indicator
- (3) Battery status indicators
- (4) Battery error indicators
- (5) Device plate





**Figure 2 Back panel**

- (1) Dust filter
- (2) Power inlet and fuses

## 3.3 Charging

### 3.3.1 General

Charger is always energized when the mains power is connected. Charging process starts automatically when a battery is inserted to the charger if any faults has observed in charge initialization routine.

Batteries are charged with a constant current. The current source is common for both the batteries i.e. only one battery can be charged at a time. Charging one battery and discharging the other is possible simultaneously.

### 3.3.2 Charge initialization

Before charging phase is allowed to start following checks has to be passed:

- $T_{\text{battery}} \geq 10 \text{ }^\circ\text{C}$ ; battery cell temperature isn't too low
- $T_{\text{battery}} \leq 40 \text{ }^\circ\text{C}$ ; battery cell temperature isn't too high
- $U_{\text{battery}} \geq 10 \text{ V}$ ; if not, battery might be deeply discharged and fast charge is prohibited. Battery is trickle charged until voltage limit is reached.
- $U_{\text{charge}} \geq 22 \text{ V}$ ; check that the power source is OK.


If the tests above is passed battery may be charged.

### 3.3.3 Discharging

If the capacity of battery is less than 50 %, it will be fully discharged before recharging. Otherwise the battery is only charged. Battery is discharged by constant current (app. 0.6 A) to 1 V / cell.



## 5 TROUBLESHOOTING

Problem	Possible cause	Solutions
Mains power ON indicator led on the front panel is not illuminated.	Primary fuses are burned.	Check both primary fuses, T2AH/250 V (p/n 511200).
	Medical power board fuse is burned.	Check the fuse, 2.5 A (p/n 511181).
Primary fuses or medical power board fuses burn down repeatedly.	Short-circuit or faulty PCB.	Find out by excluding PCBs one by one which one PCB is faulty and change it.
Error indicator is illuminated.  	Faulty batteries.	Verify condition of the batteries comparing with new ones.
	Battery slot contacts are bad.	Check and clean them.
	Battery contacts are bad.	Check and clean them.
Flashing error indicators.	The battery may be out of specified temperature 0...+ 40 °C (+ 32...+ 104 °F) or it may be damaged.	Keep the battery in room temperature at least half an hour to reach the specified temperature.  1. Remove the battery from the slot and insert it back again. If the error indicator is illuminated continuously the battery may be damaged.  2. Remove the battery from the battery slot and insert it into another – If the corresponding error indicator is illuminated continuously, the battery may be damaged.  – If the corresponding error indicator is not illuminated, return the battery to the previous battery slot. If the error indicator appears again, the charger may be damaged.
24 VDC is missing on charger board connector X2; pins 1 and 2.	Faulty board.	Change the charger board (p/n 896387).

See also *User's Reference Manual* for basic troubleshooting.

## 6 SERVICE MENU

There is no service menu available for the external battery charger.

## 7 SPARE PARTS

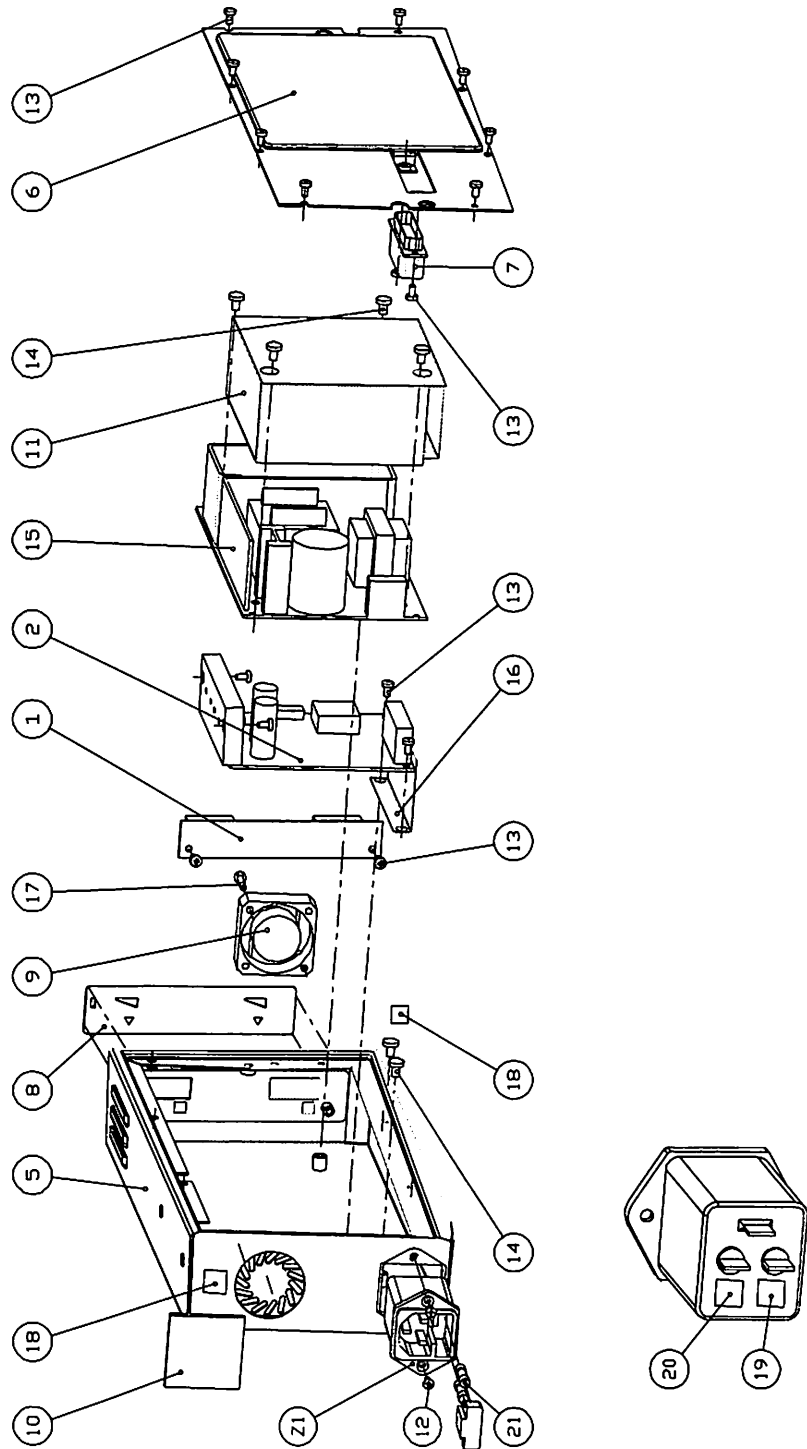
Item numbers refer to the exploded view.

### 7.1 Light external battery charger, N-LCHGR (revision 00 and 01)

Item	Item description	Order No
9	Fan 5 V DC (revision 00)	896114 a)
9	Fan 12 V DC (revision 01)	896936 a)
21	Primary fuses, 2 × T2AH/250 V, 5 × 20 mm	511200 a)
-	Medical power board fuse, 2.5 A	511181 a)
2	Charger board (revision 00)	894789 a)
2	Charger board (revision 01)	896387 a)
15	Chopper power board (Condor)	90480 a)
-	LED board	894851 a)

a) The part is recommended for stock

## 7.2 Exploded view





**DATACARD OPTION, N-LDATA (REV. 00)**

**NETWORK OPTION, N-LNET (REV. 00)**

**DATACARD AND NETWORK OPTION, N-LDNET (REV. 00, REV. 01)**

Datex-Ohmeda, Inc.  
P.O. Box 7550, Madison  
WI 53707-7550, USA  
Tel. +1-608-221-1551  
Fax +1-608-222-9147  
[www.us.datex-ohmeda.com](http://www.us.datex-ohmeda.com)

Datex-Ohmeda Division,  
Instrumentarium Corp.  
P.O. Box 900, FIN-00031  
DATEX-OHMEDA, FINLAND  
Tel. +358 10 39411 Fax +358 9 146 3310  
[www.datex-ohmeda.com](http://www.datex-ohmeda.com)  
© Instrumentarium Corp. All rights reserved.

---

## TABLE OF CONTENTS

### DATACARD OPTION, N-LDATA (REV. 00)

### NETWORK OPTION, N-LNET (REV. 00)

### DATACARD AND NETWORK OPTION, N-LDNET (REV. 00, REV. 01)

<b>1</b>	<b>INTRODUCTION</b>	<b>1</b>
<b>2</b>	<b>TECHNICAL SPECIFICATIONS</b>	<b>2</b>
<b>3</b>	<b>FUNCTIONAL DESCRIPTION</b>	<b>3</b>
3.1	General .....	3
3.2	DataCard option .....	3
3.2.1	PCMCIA host adapter.....	3
3.2.2	Voltage switching matrix .....	3
3.2.3	Single PCMCIA socket.....	4
3.3	Network option .....	4
3.3.1	Network controller .....	4
3.3.2	Network controller configuration EEPROM.....	4
3.3.3	Communication memory.....	4
3.3.4	Clock .....	4
3.3.5	Signal filtering and isolation.....	4
3.3.6	Network connector RJ-45.....	4
3.3.7	Network status LEDs.....	5
3.3.8	Coding element interface.....	5
<b>4</b>	<b>CONNECTORS AND SIGNALS</b>	<b>6</b>
4.1	Network connector.....	6
4.2	Coding element interface .....	6
4.3	ISA bus connector (X2).....	6
4.4	DataCard connector (X4).....	7
<b>5</b>	<b>SERVICE PROCEDURES</b>	<b>8</b>
<b>6</b>	<b>TROUBLESHOOTING</b>	<b>9</b>
6.1	Troubleshooting charts.....	9
<b>7</b>	<b>SERVICE VIEW</b>	<b>10</b>
7.1	Network menu .....	11
7.2	Computer interface menu.....	12
<b>8</b>	<b>EARLIER REVISIONS</b>	<b>13</b>





# 1 INTRODUCTION

## DataCard option

DataCard option (N-LDATA or N-LDNET) is used for storing patient physiological data. The DataCard with its previously recorded patient data can be transported to a new monitor with the patient enabling continuous data collection. The files created in DataCard are MS-DOS<sup>1</sup> compatible. DataCard option support only PCMCIA<sup>2</sup> ATA specification compatible flash memory cards.

## Network option

Network option (N-LNET or N-LDNET) enables connecting the S/5 Light Monitor to the S/5 network.

<sup>1</sup> MS-DOS is a trademark of Microsoft Corporation

<sup>2</sup> Personal Computer Memory Card International Association

## 2 TECHNICAL SPECIFICATIONS

### General

Total power consumption:	300 mW maximum
Connection to the CPU-board:	ISA-bus, 100pin connector

### DataCard option

PC Card socket:	one socket, type II
Data storage capacity:	2 days of continuous physiological data trends
File system:	MS-DOS compatible
DataCard:	PCMCIA ATA compatible flash memory card, 6 MB

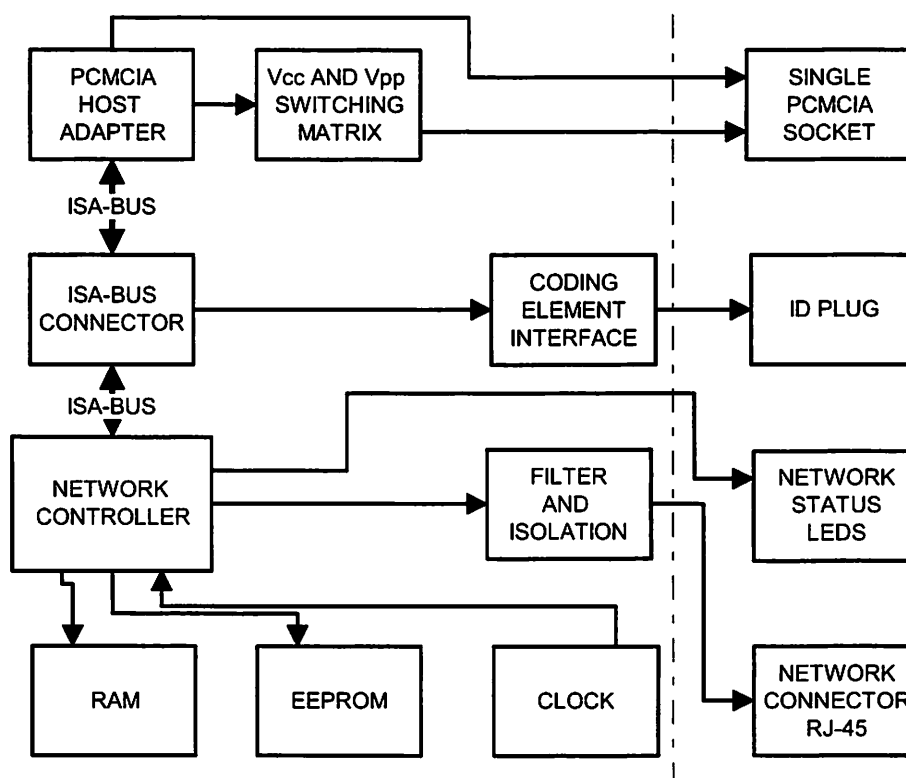
### Network option

Network interface:	10BASE-T
Isolation:	Hospital grade approved data transformer
Coding element interface:	Yes
Accordance with standards:	IEEE 802.3, IEC 601-1-1

## 3 FUNCTIONAL DESCRIPTION

### 3.1 General

Block diagram of the board:



### 3.2 DataCard option

#### 3.2.1 PCMCIA host adapter

DataCard connection is designed using single chip controller CL-PD6710 (D2) by Cirrus. Connection meets PCMCIA 2.1 specifications. Controller is connected to CPU board's ISA-bus via 100 pin connector (X2).

#### 3.2.2 Voltage switching matrix

DataCard receives its supply voltage 3.3 V or 5 V from voltage switching matrix LTC1472 (D1) controlled by Host Adapter. Supply voltage is recognized automatically.

### **3.2.3 Single PCMCIA socket**

Single PCMCIA Socket meets PCMCIA type II. There is a push button for removing the DataCard. DataCard connector allows to insert/remove DataCard when a monitor is switched ON.

## **3.3 Network option**

### **3.3.1 Network controller**

Network connection is 10Base-T and meets IEEE 802.3. Network connector is modular jack, RJ-45. A controller for network connection is single chip network controller DP83907 (D3) by National Semiconductor. It is connected to the ISA bus via 100 pin connector. Network controller creates control signals to memory circuits and to status LEDs. Between controller and network connector there is filters and isolation for transmit and receive signals.

### **3.3.2 Network controller configuration EEPROM**

For Ethernet address and initializing the controller there is a serial EEPROM programmed by manufacturer.

Ethernet address in the EEPROM is unique.

### **3.3.3 Communication memory**

For transmit and receive buffers there are two 32 kB SRAM circuits. Reading from the receive buffer and writing to the transmit buffer is done by CPU via Network controller. The Network controller maintains state of the buffers.

### **3.3.4 Clock**

For the communication there is a 20 MHz oscillator.

### **3.3.5 Signal filtering and isolation**

10Base-T interface consists lowpass filter on unisolated transmit side of the transformer and lowpass filter on unisolated receive side of the transformer. The data transformer is hospital grade approved.

On the isolated side of the transformer there is a common mode choke both for transmitting and receiving lines.

### **3.3.6 Network connector RJ-45**

Network Connector, modular jack RJ-45 is located on the rear panel of a monitor. All rear panel connectors are described in Part II/Power Supply Unit 1.3.4.

### 3.3.7 Network status LEDs

There are three status LEDs for network communication:

- **ACTIVITY** : is asserted for 50ms whenever the DP83907 transmits or receives data.
- **COLLISION**: is asserted for 50ms whenever the DP83907 detects a collision.
- **GOOD LINK**: is on if the link integrity is good (i.e. the twisted pair link has not been broken)

States of these LEDs can be checked by detaching DataCard cover plate over the recorder, or detaching the recorder or it's cover plate.

NOTE: Do not detach/insert a recorder when the monitor is switched ON.

### 3.3.8 Coding element interface

The coding element interface is connected to the CPU board via Ethernet board. Communication channel between the coding element and the CPU board is synchronous serial bus. The coding element contains an unique number which make it possible to localize the monitor connected to the network.

## **4 CONNECTORS AND SIGNALS**

### **4.1 Network connector**

See Power Supply Unit chapter 1.3.4.

### **4.2 Coding element interface**

See Power Supply Unit chapter 1.3.4.2.

### **4.3 ISA bus connector (X2)**

See CPU chapter 1.2.4.

#### 4.4 DataCard connector (X4)

pin	Signal	I/O	Description	pin	Signal	I/O	Description
1	GND		Ground	35	GND		Ground
2	CD3	I/O	Data	36	CD1#	I	Card Detect
3	CD4	I/O	Data	37	CD11	I/O	Data
4	CD5	I/O	Data	38	CD12	I/O	Data
5	CD6	I/O	Data	39	CD13	I/O	Data
6	CD7	I/O	Data	40	CD14	I/O	Data
7	CE1#	0	Card Enable	41	CD15	I/O	Data
8	CA10	0	Address	42	CE2#	0	Card Enable
9	OE#	0	Output Enable	43	NC		-
10	CA11	0	Address	44	IORD#	0	I/O Read
11	CA9	0	Address	45	IOWR#	0	I/O Read
12	CA8	0	Address	46	CA17	0	Address
13	CA13	0	Address	47	CA18	0	Address
14	CA14	0	Address	48	CA19	0	Address
15	WE#	0	Write Enable	49	CA20	0	Address
16	RDY	I	Ready	50	CA21	0	Address
17	CVCC	-	Power Supply	51	CVCC	-	Power Supply
18	CVPP	-	Programming Voltage	52	CVPP	-	Programming Voltage
19	CA16	0	Address	53	CA22	0	Address
20	CA15	0	Address	54	CA23	0	Address
21	CA12	0	Address	55	CA24	0	Address
22	CA7	0	Address	56	CA25	0	Address
23	CA6	0	Address	57	5V_DET	I	5V Detect
24	CA5	0	Address	58	RST	0	Reset
25	CA4	0	Address	59	WAIT#	I	Wait
26	CA3	0	Address	60	INPACK#	I	Input Acknowledge
27	CA2	0	Address	61	REG#	0	Register Access
28	CA1	0	Address	62	BVD2	I	Battery Voltage Detect
29	CA0	0	Address	63	BVD1	I	Battery Voltage Detect
30	CD0	I/O	Data	64	CD8	I/O	Data
31	CD1	I/O	Data	65	CD9	I/O	Data
32	CD2	I/O	Data	66	CD10	I/O	Data
33	WP	I	Write Protect	67	CD2#	I	Card Detect
34	GND		Ground	68	GND		Ground



## 5 SERVICE PROCEDURES

Due to the nature of the network board, field service is limited to troubleshooting. The circuit boards should be returned to Datex-Ohmeda for repair.

Datex-Ohmeda is always available for service advice. Please provide the unit serial number, full type designation, and a detailed fault description.

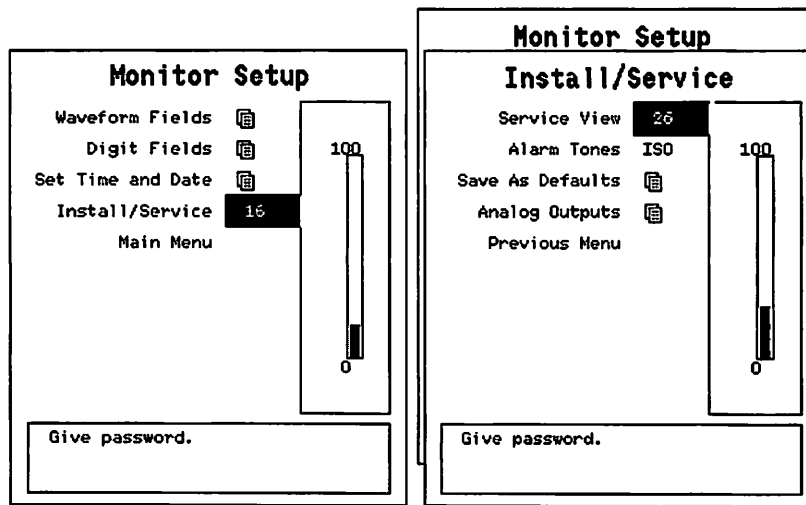
**CAUTION** Only trained personnel with appropriate tools and equipment are allowed to perform the tests and repairs outlined in this section. Unauthorized service may void warranty of the unit.

## 6 TROUBLESHOOTING

### 6.1 Troubleshooting charts

Symptom at the monitor end	Problem at	Explanation/correction
<p>Monitor does not connect to network.</p> <p>Monitor connects to network, but disconnects unexpectedly ("Network xxx down" message on the monitor screen. xxx = networks name).</p>	Monitor-Network cable	Cable not properly connected to wallplate or to monitor.
	Monitor-Network cable	Cable or connector defective.
	Network board	The network board is defective. The board cannot be used. See network service page for details.
	Identification plug	There is no Identification plug properly attached to the monitor.
	Identification plug	The identification plug is defective or uninitialized. The plug cannot be used
"Check network connectors" message shows on the monitor screen	Identification plug	There is no identification plug properly attached to the monitor.
	Identification plug	The Identification plug is defective or uninitialized. The plug cannot be used. See network service page for details.
Network printing fails	Print server is busy	Network manager's print server is busy at the moment and cannot take more print jobs. Try again after 15 seconds.
	Print queue is full	There are too many unprinted documents waiting in the print queue. Check the printer, as it is not operating properly.
	Printer is off-line	Printer cable is loose, printer is out of paper, there is paper jam or the printer is simply switched to off-line state.

## 7 SERVICE VIEW



1. Press the **Menu** key.
2. Select **Monitor Setup**.
3. Select **Install/Service** (password 16-4-34).
4. Select **Service View** (password 26-23-8).
5. Select **Monitor**.
6. Select **Communication**.



Overrun errors (Overrun)	Practically same as above.	Must always be 0.
Location ID	ID plug	Must equal to ID plug
Address	Monitor's ethernet address	
Connections	Names of DEICs connected	
DMA packets *)	Total number of DMAs to/from controller	*) not seen on figure above
Lost IRQ packets *)	Number of lost IRQ packets	

## 7.2 Computer interface menu

Communication	Computer If.
Network	Interface status CLOSED
Computer If.	Statistics In Out
	Packets 0 0
	Bytes 0 0
Previous Menu	Rx errors 0

### Computer If.

**Computer If.** displays interface related service data.

## 8 EARLIER REVISIONS

PC/E-Board, 891437 Rev. 0

Functionally same as 891437 Rev. 1.

PC-Board, 894697

There are no earlier revisions of PC-Board

E-Board, 894698

There are no earlier revisions of PC-Board



## **UPGRADE KITS, SPARE PARTS AND EXPLODED VIEWS**

All specifications are subject to change without notice.

Datex-Ohmeda, Inc.  
P.O. Box 7550, Madison  
WI 53707-7550, USA  
Tel. +1-608-221-1551  
Fax +1-608-222-9147  
[www.us.datex-ohmeda.com](http://www.us.datex-ohmeda.com)

Datex-Ohmeda Division,  
Instrumentarium Corp.  
P.O. Box 900, FIN-00031  
DATEX-OHMEDA, FINLAND  
Tel. +358 10 394 11 Fax +358 9 146 3310  
[www.datex-ohmeda.com](http://www.datex-ohmeda.com)  
© Instrumentarium Corp. All rights reserved.



---

# TABLE OF CONTENTS

## UPGRADE KITS, SPARE PARTS AND EXPLODED VIEWS

<b>TABLE OF CONTENTS</b>	<b>i</b>
<b>1 Upgrade kits</b>	<b>1</b>
1.1 Installation Guides .....	1
<b>2 Spare Parts</b>	<b>3</b>
2.1 Light Monitor, F-LM1 and F-LMP1 .....	4
2.1.1 Back cover unit (896908) .....	8
2.1.2 CO <sub>2</sub> / Mainstream option (893373) .....	9
2.1.3 Connector panels and push buttons .....	10
2.1.4 Display unit .....	12
2.1.5 Chassis .....	13
2.1.6 Recorder unit .....	14
2.1.7 Pneumatic unit .....	15
2.1.8 NIBP unit .....	16
2.1.9 Pump unit .....	17
2.1.10 Parameter unit .....	18
2.1.11 SpO <sub>2</sub> /Nellcor option, N-LNSAT .....	19
2.2 Light Monitor Recorder, N-LREC .....	19
2.3 Light Monitor Power Adapters, N-LPOW & N-LPOWT .....	19
2.4 Light Monitor Battery Module, F-LBAT .....	19
2.5 Light External Battery Charger, N-LCHGR (revision 00 and 01) .....	20
<b>3 Ribbon cables and connectors</b>	<b>22</b>
<b>APPENDICES</b>	<b>23</b>

This page intentionally left blank.

# 1 UPGRADE KITS

The monitor can be field upgraded with following options:

Option	Description	Order code
Mainstream CO <sub>2</sub> Option	CO <sub>2</sub> can be measured with mainstream method. Respiration rate is the frequency of the peak (end tidal) CO <sub>2</sub> value per minute.	N-LCM
DataCard Option	The DataCard is a rewritable flash memory card. With the DataCard, the patient trend data collected with the Light Monitor can be transferred to other S/5 monitors.	N-LDATA
Network Option	When the monitor is connected to network: <ul style="list-style-type: none"> <li>– Time and date are set by the network, and cannot be adjusted in the monitor.</li> <li>– Patients name can be entered in the Patient Data menu to be displayed on the Information Center's (IC) and the monitor's screen and printed on the laser printouts.</li> <li>– Measured and entered patient data can be viewed on the IC.</li> <li>– Measured patient data and alarms can be viewed on other Datex-Ohmeda S/5 monitoring systems, but not vice versa.</li> </ul>	N-LNET
DataCard & Network Option	Includes both options described above.	N-LDNET
Battery Module Option	Enables upto 2 hour monitoring w/o mains power	F-LBAT
Thermal Recorder Option	Enables waveform and trend recording	N-LREC

## 1.1 Installation Guides

Installation guides for N-LCM, N-LDNET, N-LDATA and N-LNET are attached as appendices in the end of this document.



## 2 SPARE PARTS

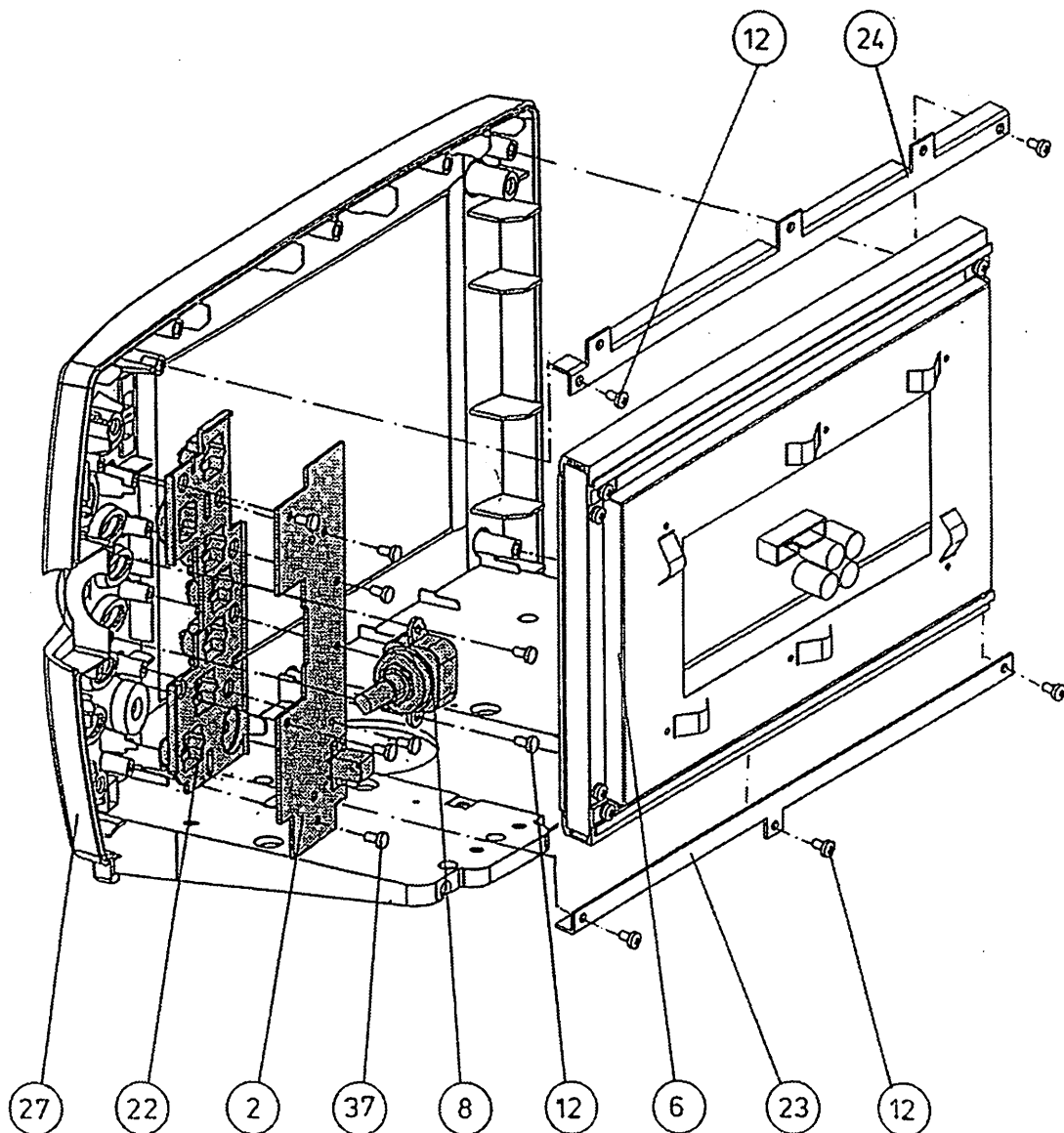
Item numbers refer to the exploded view beside/below the table.

NOTE: Accessories are listed in the *Patient Monitor Supplies and Accessories Catalogue*.

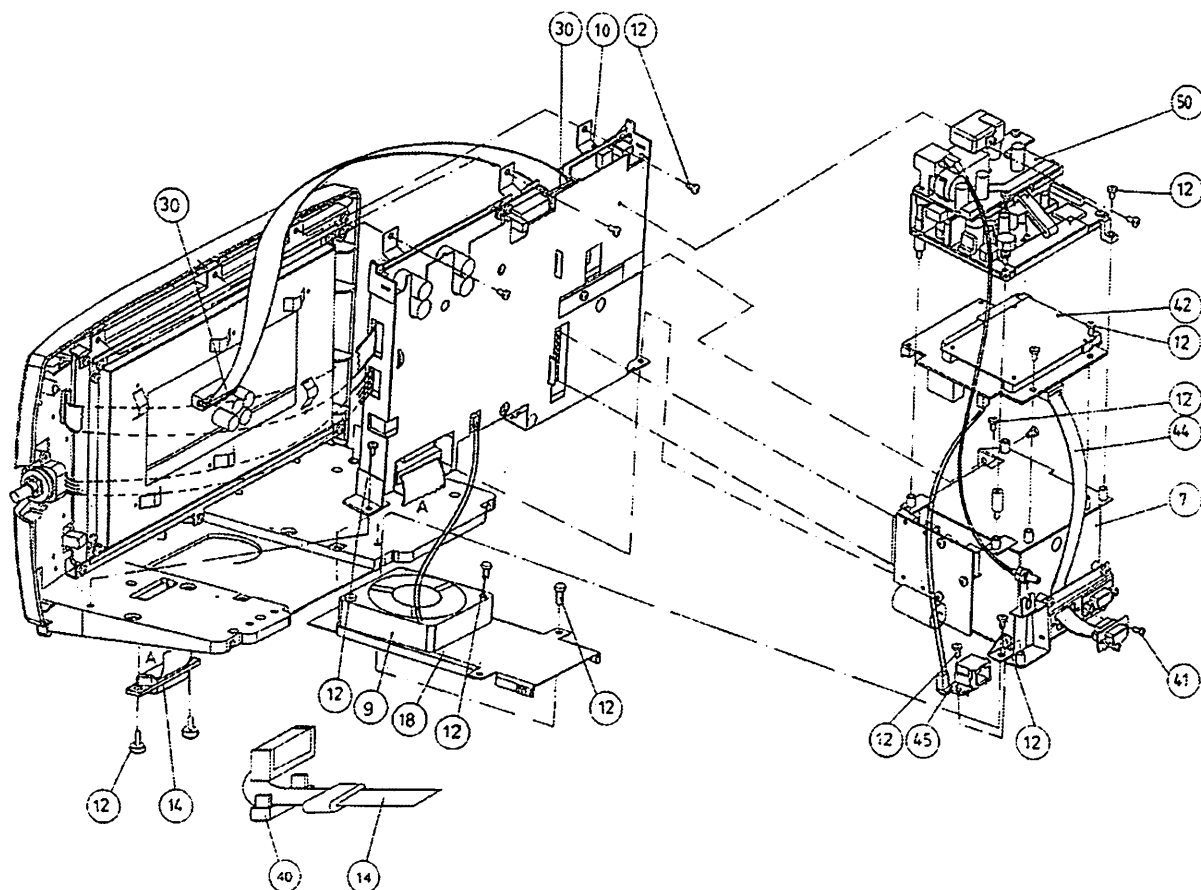
a) means that the part is recommended for stock

## 2.1 Light Monitor, F-LM1 and F-LMP1

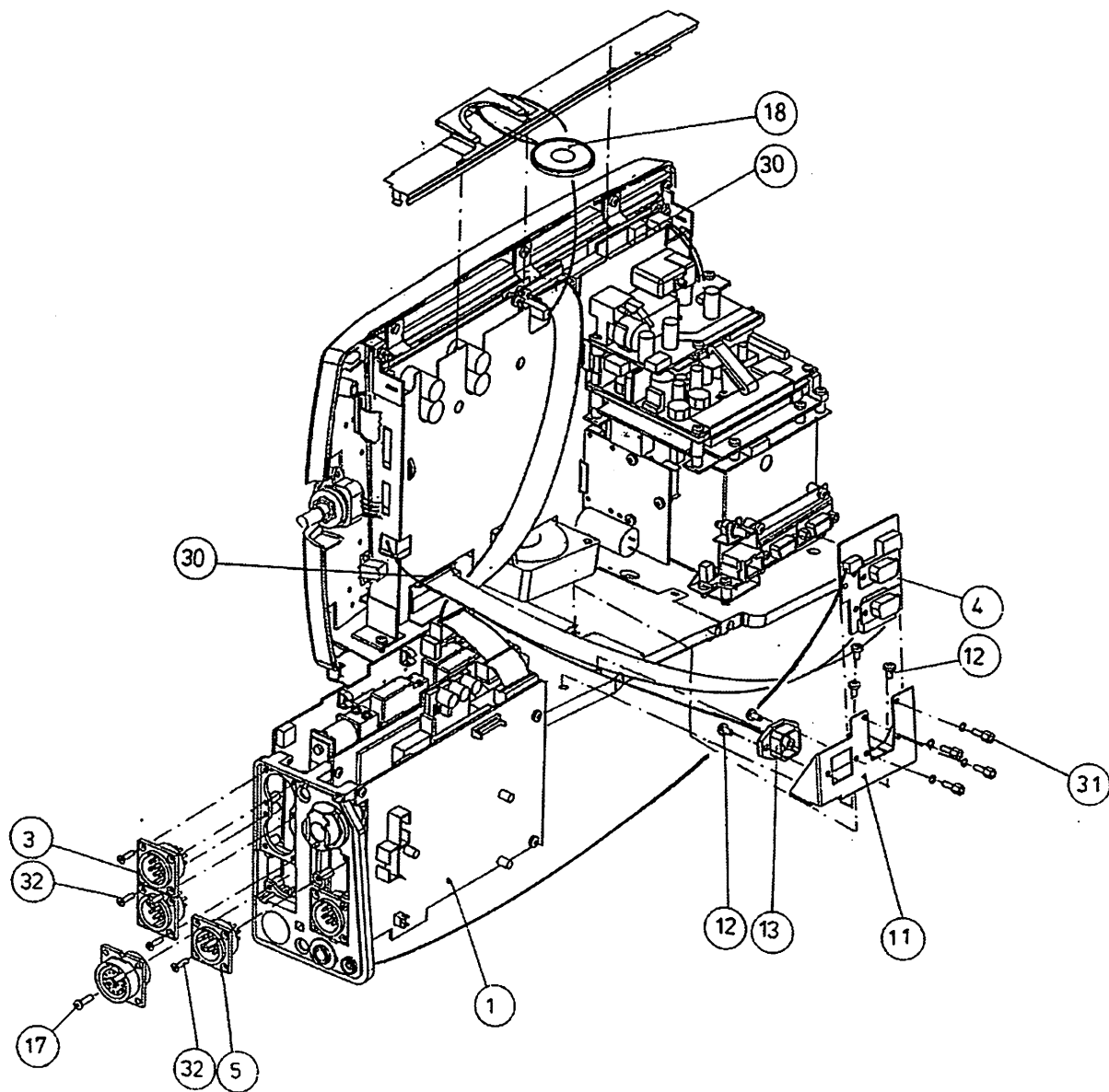
Item	Item description	Order No.
2	Keyboard PCB, LM1	892089
6	Display Unit, LM1 (incl. CPU board)	898813
8	ComWheel, LM1	887641
	ComWheel frame, LM1	886625
12	Cross cyl.-head screw M3x6 tufflock (7 pcs)	617210
22	Silicon cover for keyboard, LM1	886722
23	Display unit lower rail	886733
24	Display unit upper rail	891096
27	Front cover	898366
37	PT screw M3x8 (7 pcs)	628712



Item	Item description	Order No.
7	Recorder Unit	892510
9	Fan	892539
10	PCB housing	892514
12	Cross cyl.-head screw M3x6 tufflock (18 pcs)	617210
14	Battery cable, LM	887653
18	Fan bracket, LM	886711
30	Locking rib	546843
40	Locking bar	546983
41	Screw-cross M2.5x6 STZN (2 pcs)	617120
42	PC/E board	891437
42	PC board	894697
42	E board	894698
44	ID cable	892524
45	Connector board, 10 Base-T, F-LMP1	892996
50	N-LCM Mainstream Module assembly	893373
-	D-SYNC four pin cord connector	546286



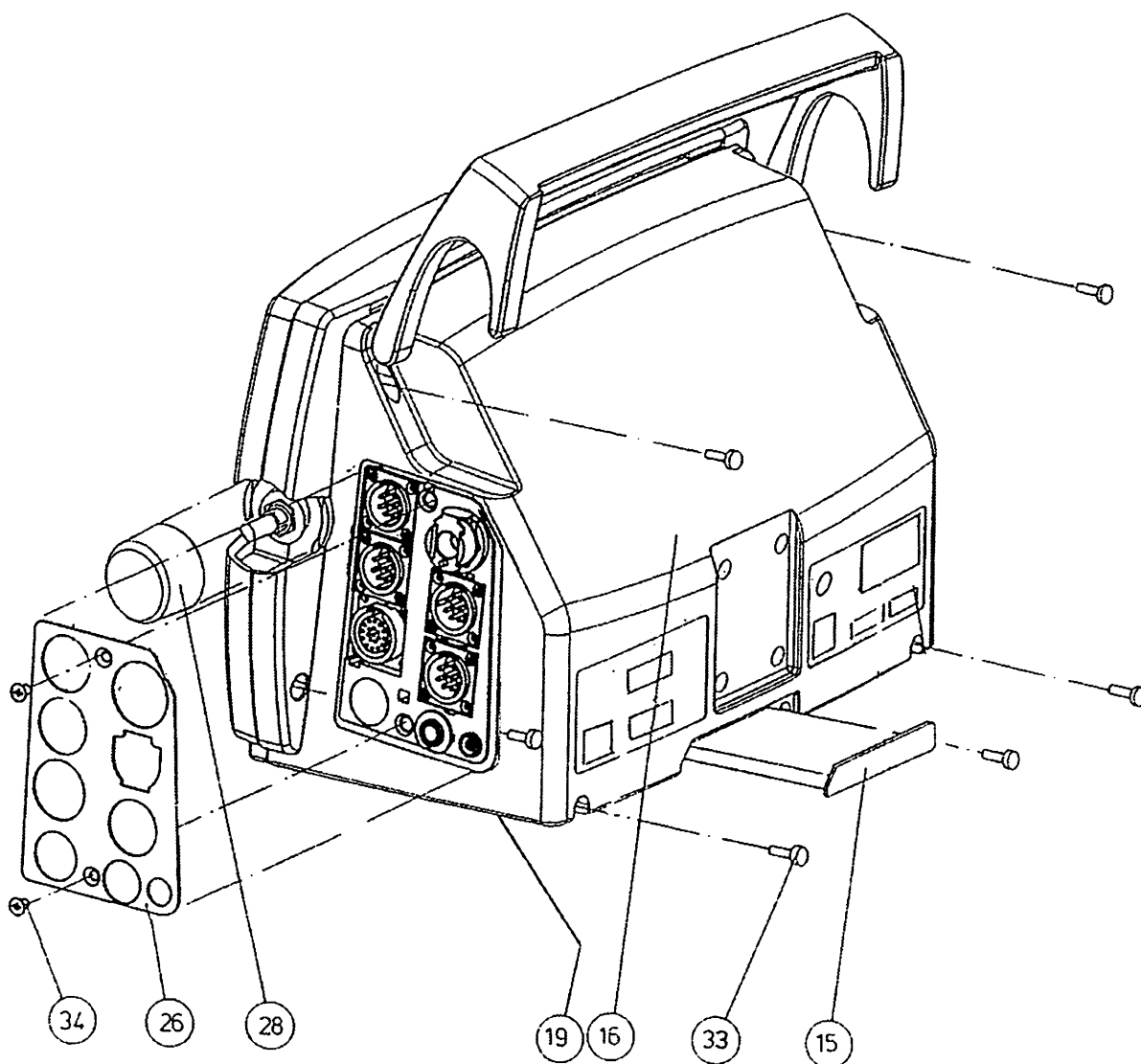
Item	Item description	Order No.
1	Parameter Unit	897602
3	InvBP input board, F-LMP1	891258
4	RS board, LM1	891511
5	SpO <sub>2</sub> input board, LM1	891255
11	Connector plate	892546
12	Cross cyl.-head screw M3x6 tufflock (5 pcs)	617210
13	POW cable, LM	892081
17	PT screw M3x10	628703
18	Loudspeaker unit, LM1	892545
30	Locking rib	546843
31	Block screw D-female (4 pcs)	546096
32	PT screw M2.5x10	628708





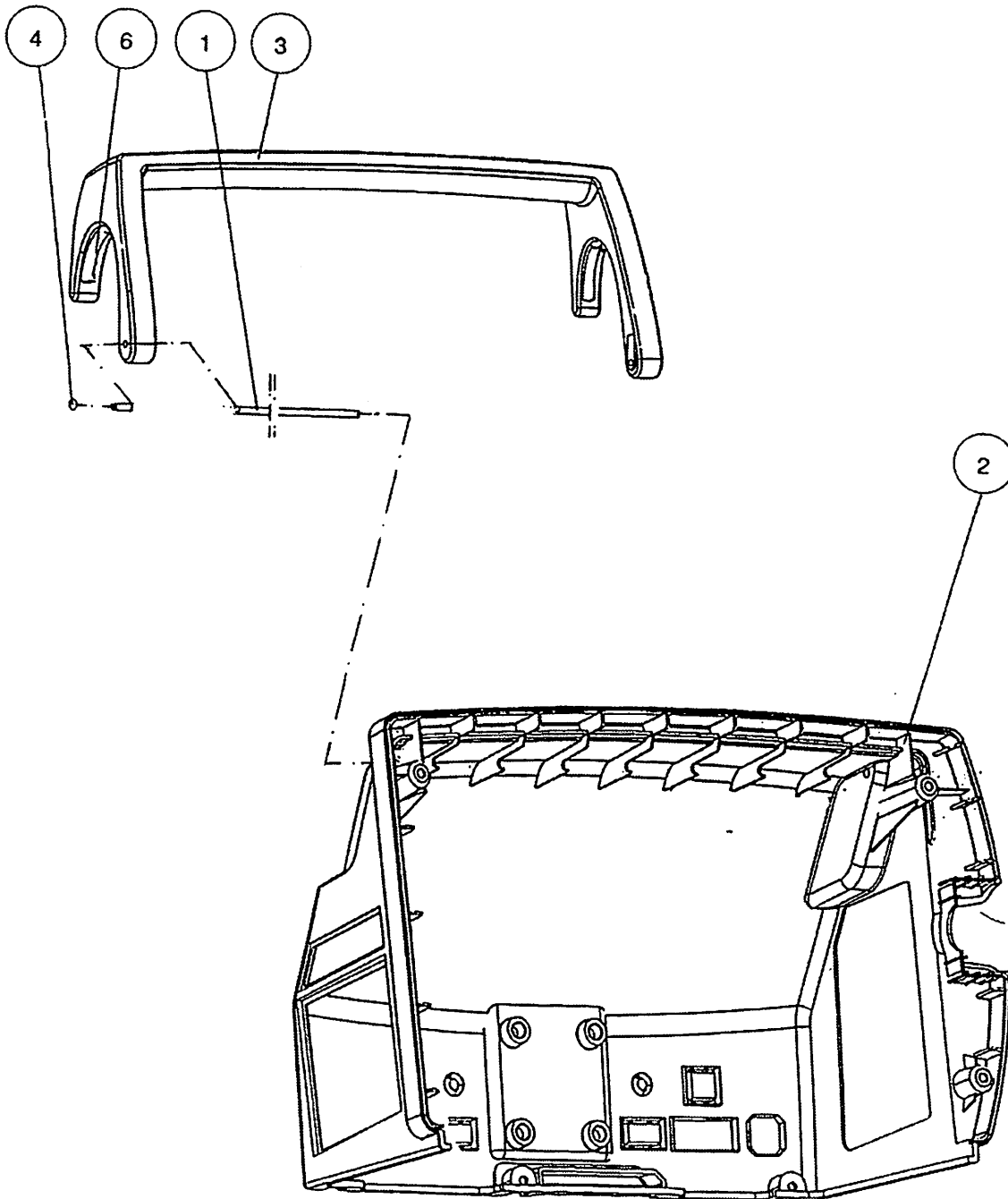
Item	Item description	Order No.
15	Filter cassette unit	896909
15	Filter	886841 a)
16	Back cover unit, complete with handle	896908 b)
19	Bottom plate	896687
26	Patient connector plate LM1	891131
26	Patient connector plate LMP1	891132
26	Patient connector plate LM1+N-LCM	891133
26	Patient connector plate LMP1+N-LCM	891134
28	ComWheel knob, LM1	8000460
33	Cross cylinder-head screw M4x10 (6 pcs)	61752
34	Screw-cross rec c/s h., M4x6, strc bla (2 pcs)	61647

b) Contact Datex-Ohmeda for device plate



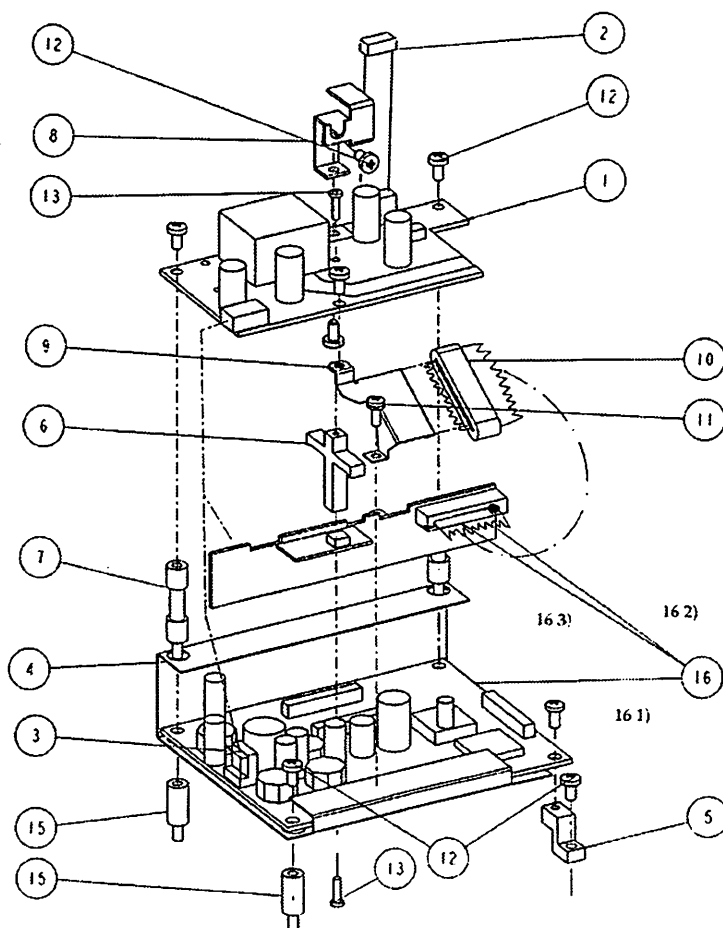
**2.1.1 Back cover unit (896908)**

Item	Item description	Order No
1	Shaft bar	886728 a)
2	Rear enclosure	896690
3	Handle	896688
4	Lock ring	63900 a)
6	Interlock	888932 a)



2.1.2 CO<sub>2</sub> / Mainstream option, N-LCM

Item	Item description	Order No
1	CO <sub>2</sub> power board	891270 a)
2	CO <sub>2</sub> module cable	892529
3	CO <sub>2</sub> /power - MS cable	894752
4	Insulant plate	891141
5	Recess bracket	891142
6	Board holder	891143
7	Insulant bushing	891144
8	Board rest	892527
9	Ferrite holder	894480
10	Ferrite ring for flat cable, 20-pole	304511
11	Screw	616263
12	Cross cyl.-head screw M3x6 tufflock	617210
13	PT screw 2.2x8	628701
15	Insul nylonpost, 13x6.5, M3 male/female	640445
16 1)	CO <sub>2</sub> Main board	902403 a)
16 2)	Mainstream board	902402 a)
16 3)	Flex cable	902401 a)
-	CO <sub>2</sub> / Mainstream assembly	893373



### 2.1.3 Connector panels and push buttons

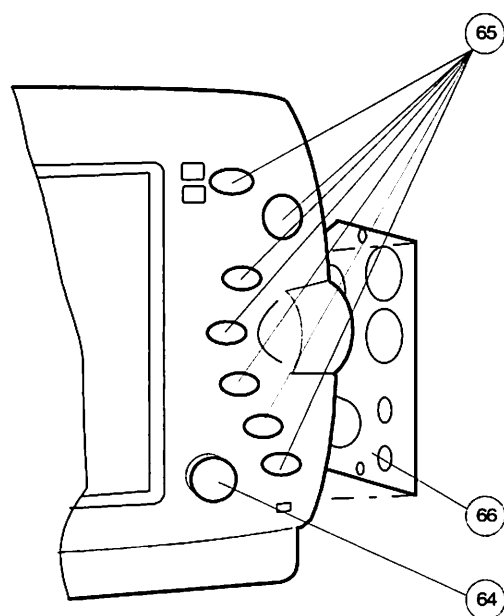
Item	Item description	Order No
64	ON/STBY switch	896835
65	Push button set, EN	896281
65	Push button set, DE	896282
65	Push button set, FR	896283
65	Push button set, NL	896284
65	Push button set, SV	896285
65	Push button set, FI	896286
65	Push button set, ES	896287
65	Push button set, IT	896288
65	Push button set, NO	897890
65	Push button set, PT	897891

Item	Item description	Order No F-LM1	Order No F-LMP1
66	Connector panel, EN	896746	896756
66	Connector panel, NO	896984	896765
66	Connector panel, IT	896751	896761
66	Connector panel, NL	896749	896759
66	Connector panel, DE	896747	896757
66	Connector panel, FR	896748	896758
66	Connector panel, SV	896754	896764
66	Connector panel, DA	896755	896766
66	Connector panel, FI	896753	896763
66	Connector panel, ES	896750	896760
66	Connector panel, PT	896752	896762

Item	Item description	Order No F-LM1+N-LNSAT	Order No F-LMP1+N-LNSAT
66	Connector panel, EN	896788	896810
66	Connector panel, NO	896797	896819
66	Connector panel, IT	896793	896815
66	Connector panel, NL	896791	896813
66	Connector panel, DE	896789	896811
66	Connector panel, FR	896790	896812
66	Connector panel, SV	896796	896818
66	Connector panel, DA	896798	896820
66	Connector panel, FI	896795	896817
66	Connector panel, ES	896792	896814
66	Connector panel, PT	896794	896816

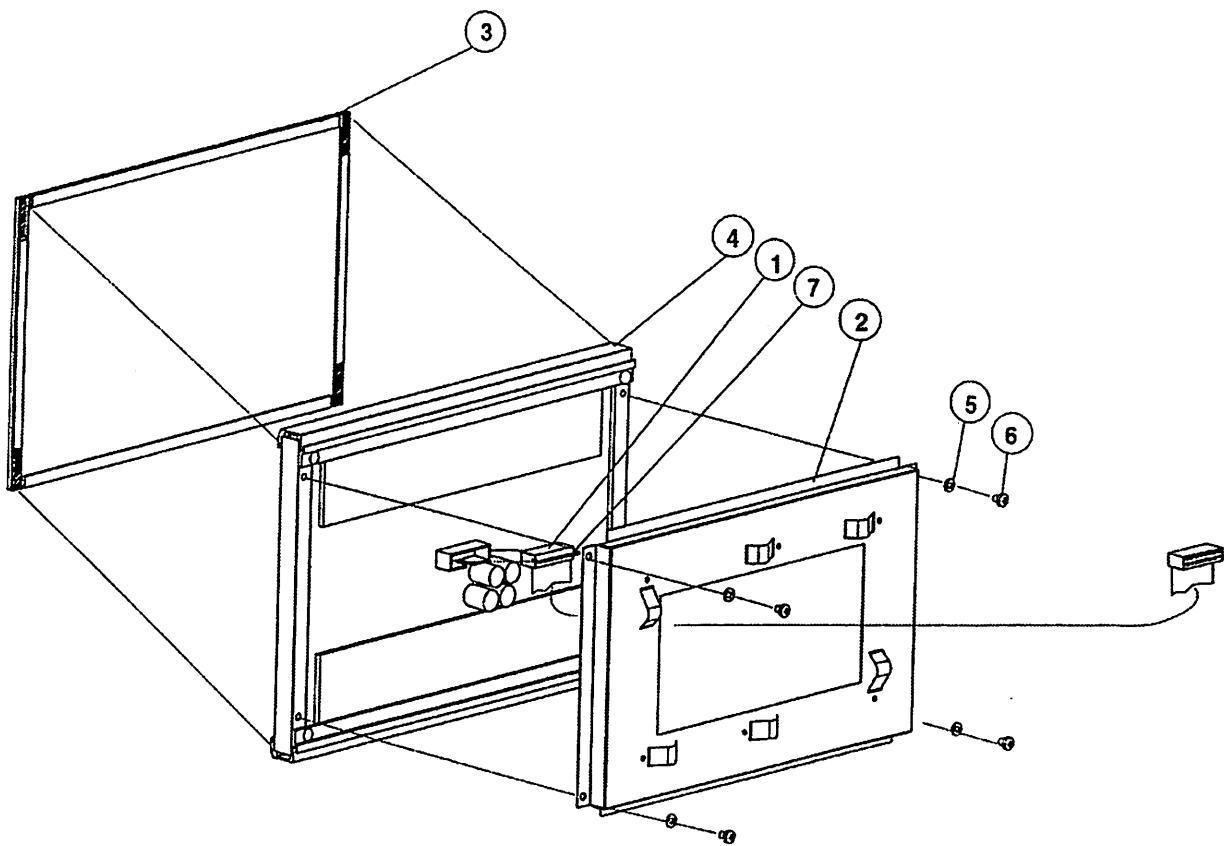
Item	Item description	Order No F-LM1 + N-LCM	Order No F-LMP1 + N-LCM
66	Connector panel, EN	896767	896777
66	Connector panel, NO	896983	896786
66	Connector panel, IT	896772	896782
66	Connector panel, NL	896770	896780
66	Connector panel, DE	896768	896778
66	Connector panel, FR	896769	896779
66	Connector panel, SV	896775	896785
66	Connector panel, DA	896776	896787
66	Connector panel, FI	896774	896784
66	Connector panel, ES	896771	896781
66	Connector panel, PT	896773	896783

Item	Item description	Order No F-LM1+N-LNSAT+N-LCM	Order No F-LMP1+N-LNSAT+N-LCM
66	Connector panel, EN	896799	896821
66	Connector panel, NO	896808	896830
66	Connector panel, IT	896804	896826
66	Connector panel, NL	896802	896824
66	Connector panel, DE	896800	896822
66	Connector panel, FR	896801	896823
66	Connector panel, SV	896807	896829
66	Connector panel, DA	896809	896831
66	Connector panel, FI	896806	896828
66	Connector panel, ES	896803	896825
66	Connector panel, PT	896805	896827



### 2.1.4 Display unit

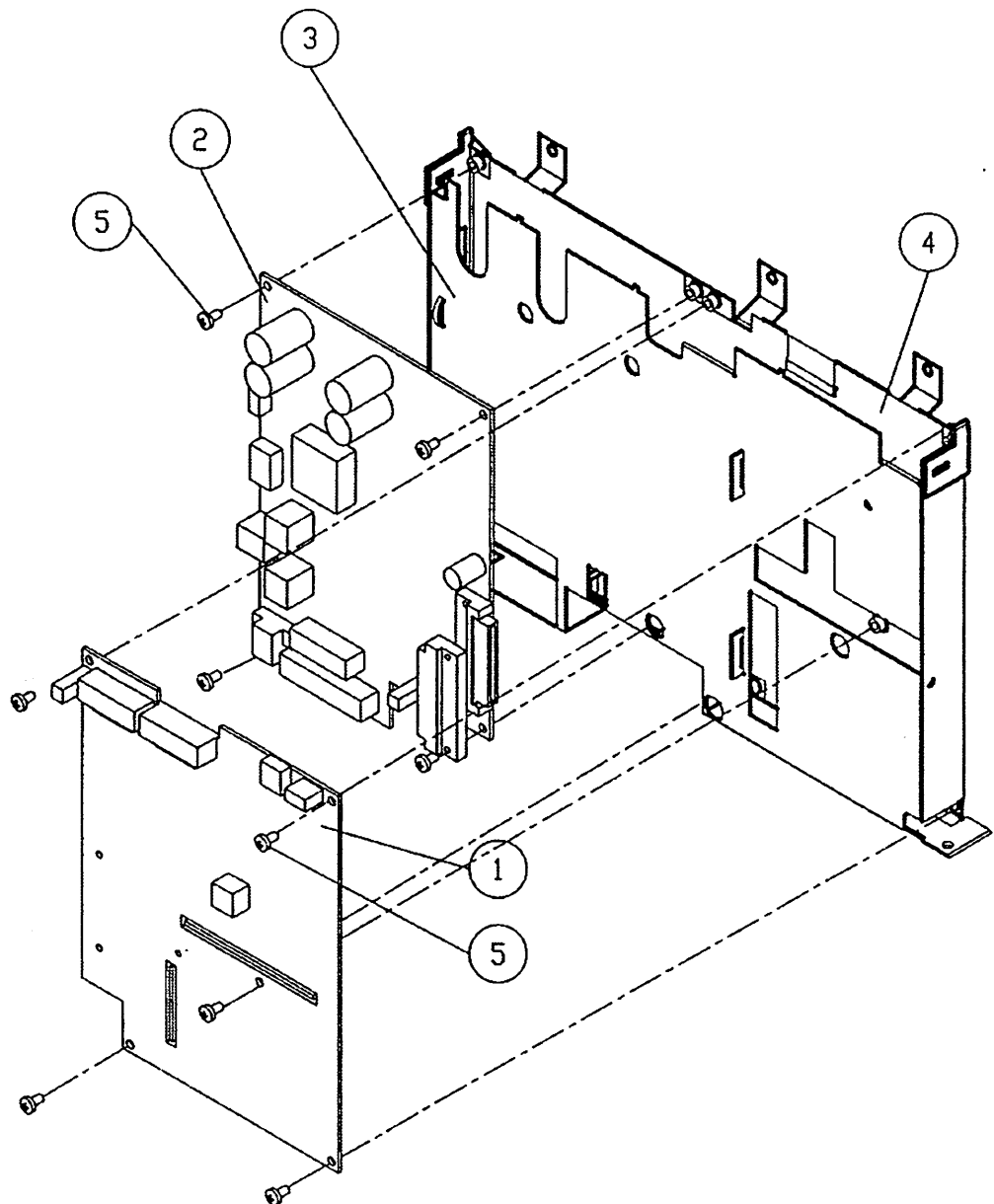
Item	Item description	Order No
1	Display ribbon cable	892521
2	EMC-cover B	890654
3	Display cover, LM	572786
5	Shakeproof washer STZN, M3.2 (4 pcs)	63611
6	Cross cylinder-head screw M3x4 (4 pcs)	61719
7	Locking clips for P/N 546826	546827
-	Display unit, complete (incl. CPU board)	898813



## 2.1.5 Chassis

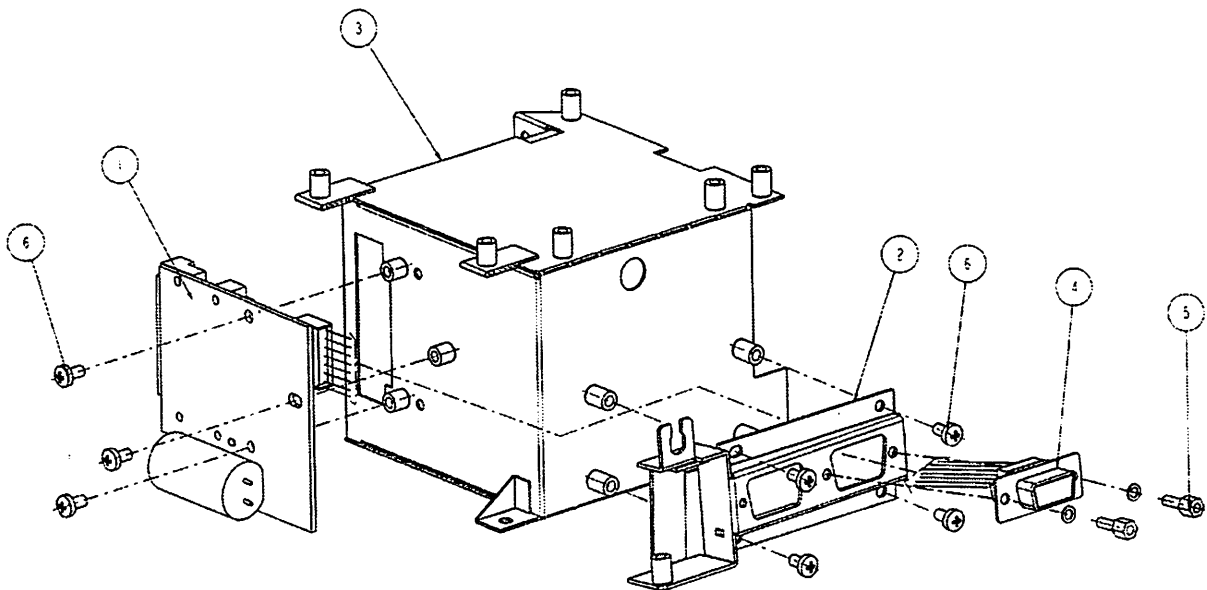
Item	Item description	Order No
1	CPU Board (incl. assembly ID 8001608)	891537 a)
-	Battery for SRAM/Timekeeper	197230 a)
2	Power Supply Board	891120
3	Chassis, LM1	890655
4	Isolation plate	887992
5	Cross cyl.-head screw M3x6 tufflock (9 pcs)	617210

a) The part is recommended for stock



### 2.1.6 Recorder unit

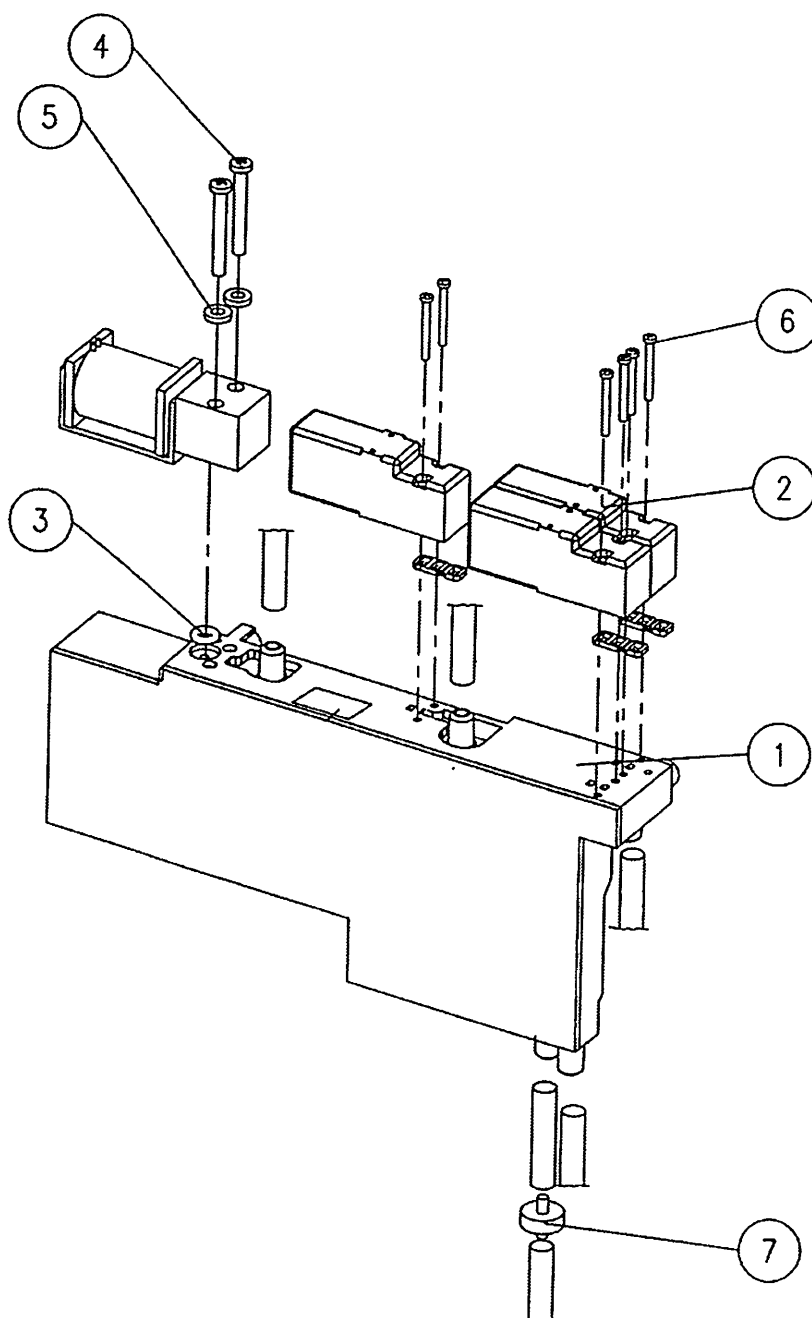
Item	Item description	Order No
1	Recorder board	892511
2	Connector board	891135
3	Recorder housing	891097
4	VGA cable	892528
5	Block screw D-female (2 pcs)	546096
6	Cross cyl.-head screw M3x6 tufflock (7 pcs)	617210
-	Paper holder	90351





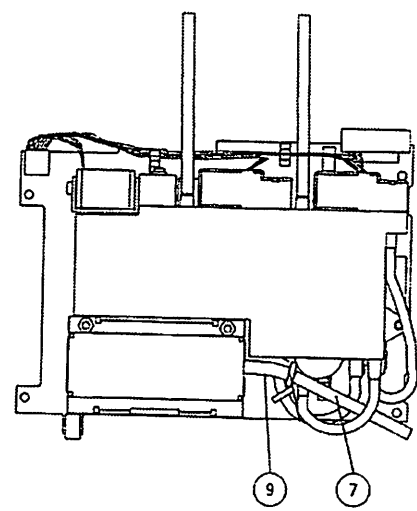
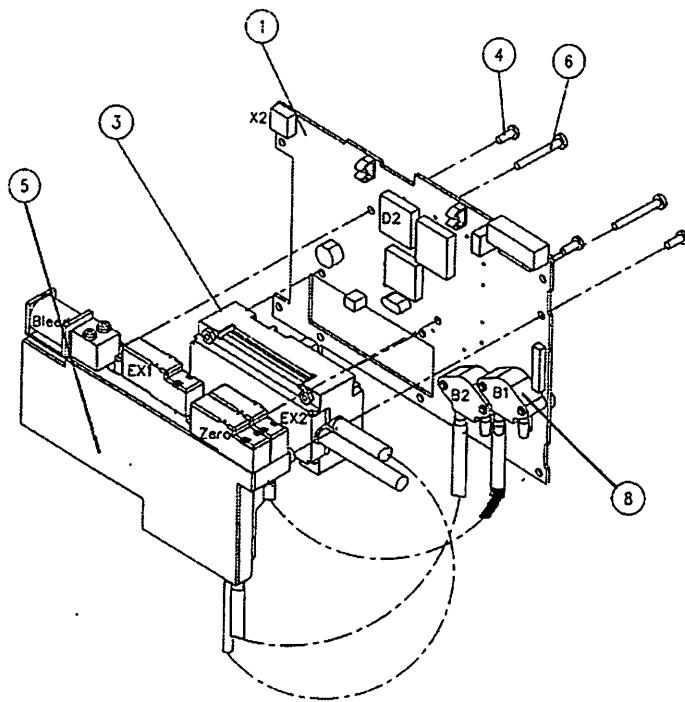
**2.1.7 Pneumatic unit**

Item	Item description	Order No
1	NIBP damping chamber	888240
2	Magnetic valves (4 pcs)	894508
3	O-ring	65340
4	PT-screw 2.5x20 mm	628718
5	Washer STZN, M2.5	63606
6	PT screw M1.5x14+/-0.55 mm	628715
7	Check Valve	58542
-	Silicon tube 3,18/6,35	73375



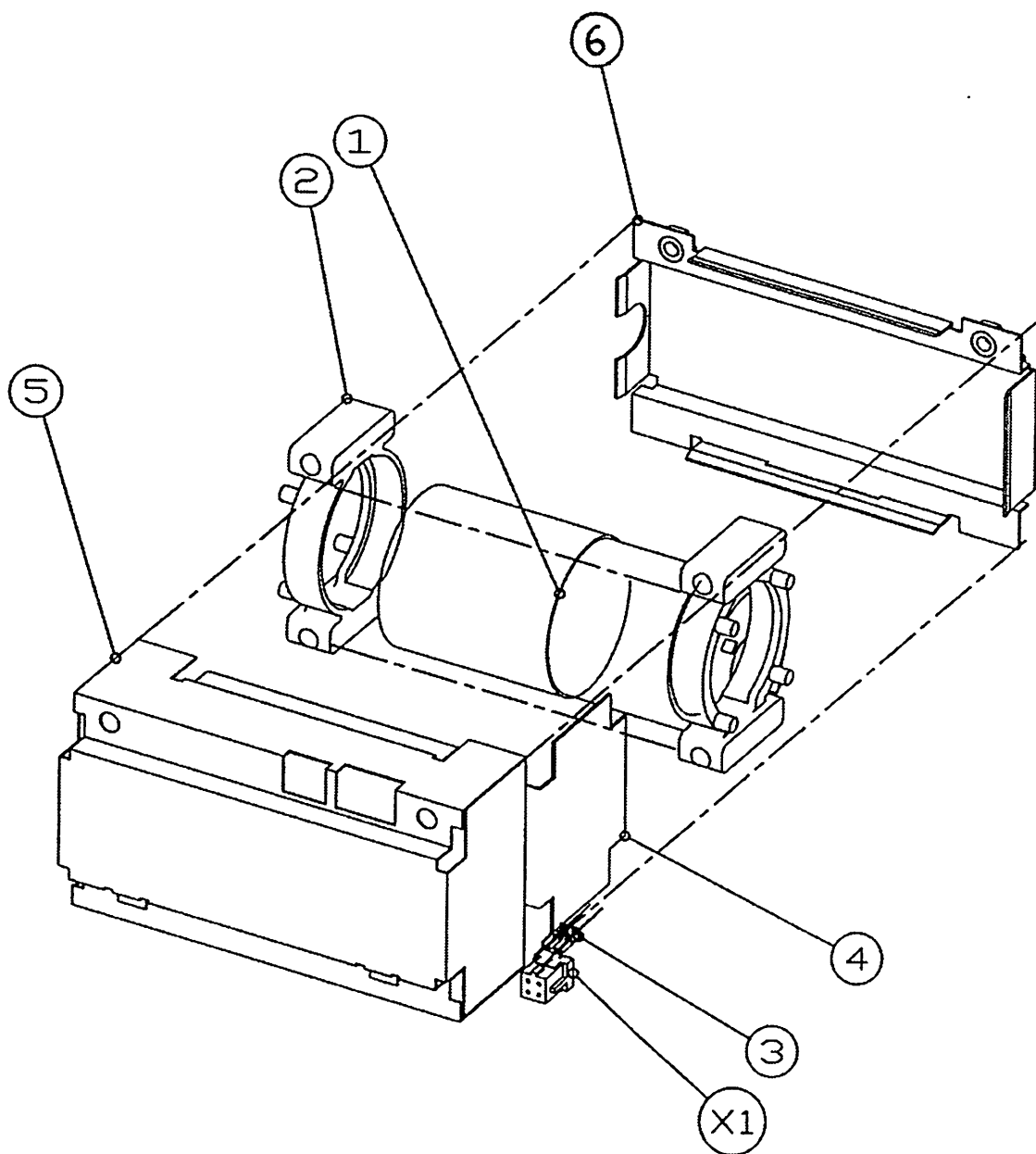
### 2.1.8 NIBP unit

Item	Item description	Order No
1	NIBP board, LM1	890658 a)
3	Pump unit	892518 a)
4	Screw cross rec. cylind. h. stzn, M3x25	61742
5	Pneumatic unit	892517 a)
6	PT screw M3x8	628712
7	NIBP pump filter, LM1	57142 a)
8	Pressure sensor	16539
-	Clip for pressure sensor	64036
9	Tube silicon 3,18/6,35 mm	73375



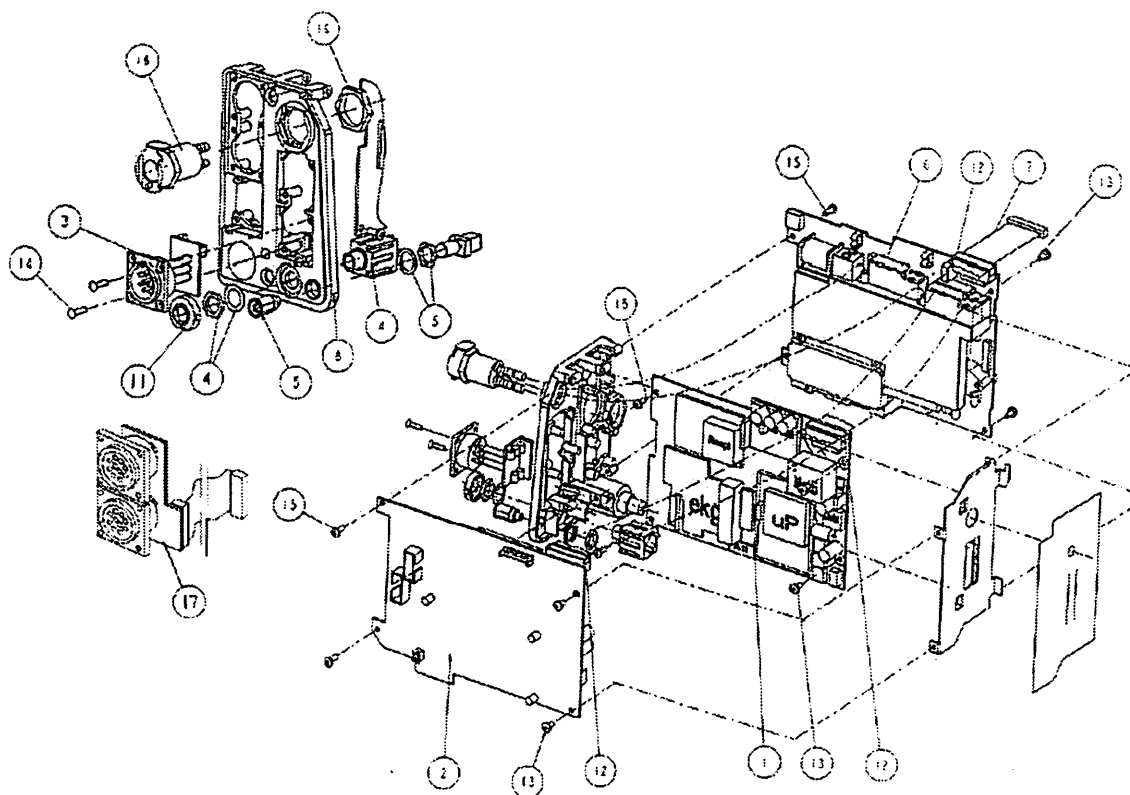
**2.1.9 Pump unit**

Item	Item description	Order No
1	Air pump	573101
2	Clip for pump (2 pcs)	888231
3	Crimp	546499
4	Insulator plate	892301
5	EMC lower side	888232
6	EMC cover side	888234
X1	Connector-wire 4-way	54843



### 2.1.10 Parameter unit

Item	Item description	Order No
1	ECG board	890673 a)
2	STP board	8001278
3	ECG input board	891544
4	Temp connector unit	891547
5	DSYNC connector	891548
6	NIBP unit	892519
7	Module cable	892526
8	Patient connector frame	896294
11	Insulator for Temp connector	891146
12	Locking rib	546843
13	Cross cyl.-head screw M3x6 tufflock (2 pcs)	617210
14	PT screw M2,5x10 (2 pcs)	628708
15	PT screw M3x8 (2 pcs)	628712
16	NIBP hose connector	64654
17	InvBP input board	891258



**2.1.11 SpO<sub>2</sub>/Nellcor option, N-LNSAT**

Item	Item description	Order No
-	SpO <sub>2</sub> /NELLCOR option, N-LNSAT	893375
-	Cable lock, M-NSAT	887706 a)
-	Nellcor-data -cable Light Monitor	892530
-	Connector board, N-LNSAT	895698
-	Sensor kit oximetry module	90312 a)

**2.2 Light Monitor Recorder, N-LREC**

Item description	Order No
Recorder	90353 a)

**2.3 Light Monitor Power Adapters, N-LPOW & N-LPOWT**

Item description	Order No
Fuse T2AH, 250V	511393 a)
Output cable	897703
Finger screw for cable	887670

**2.4 Light Monitor Battery Module, F-LBAT**

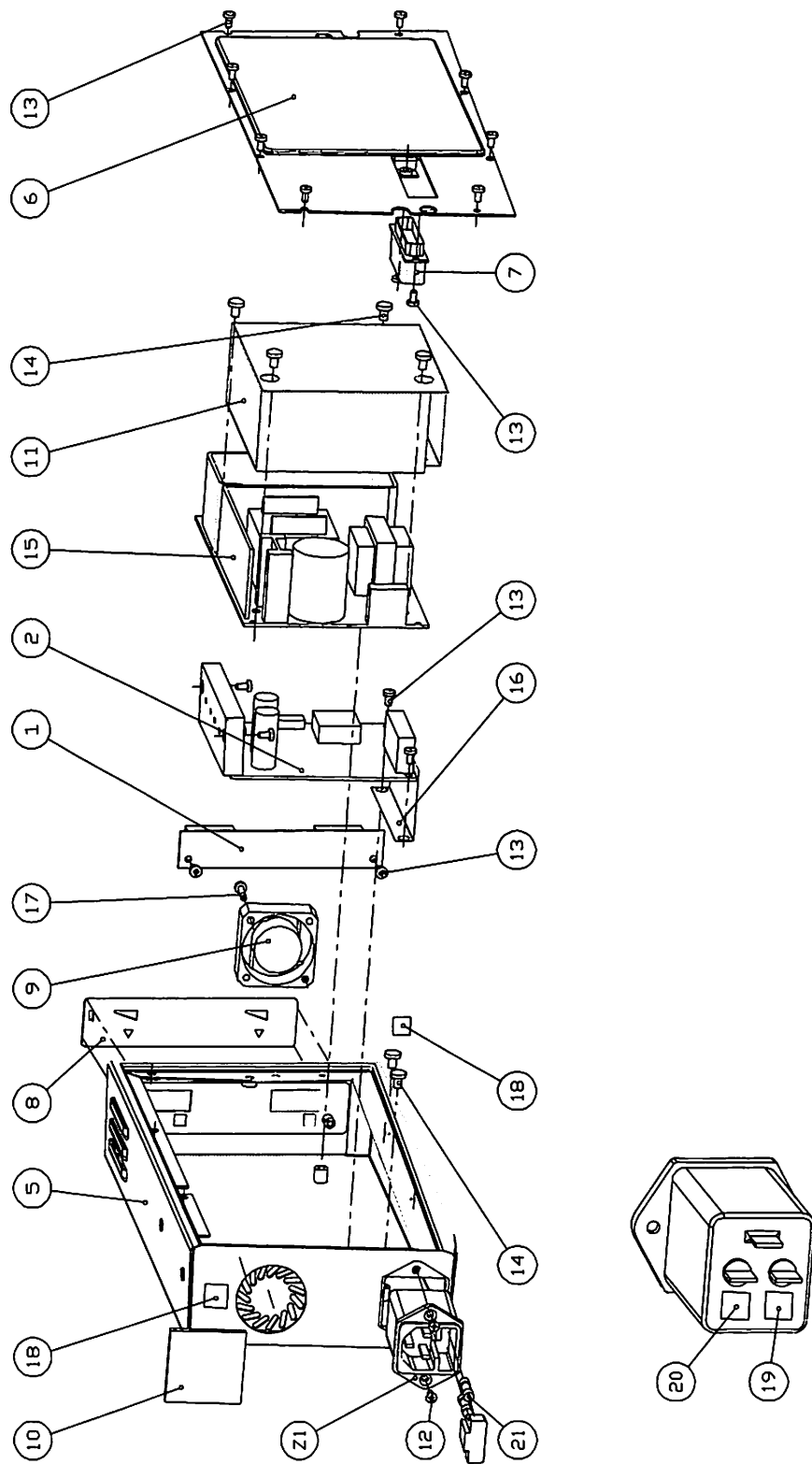
Item description	Order No
Light Monitor Battery Module Frame	8000566
NiCd Battery, 13.2 V, 1.8 Ah	896895 a)
Pad	65145

a) The part is recommended for stock

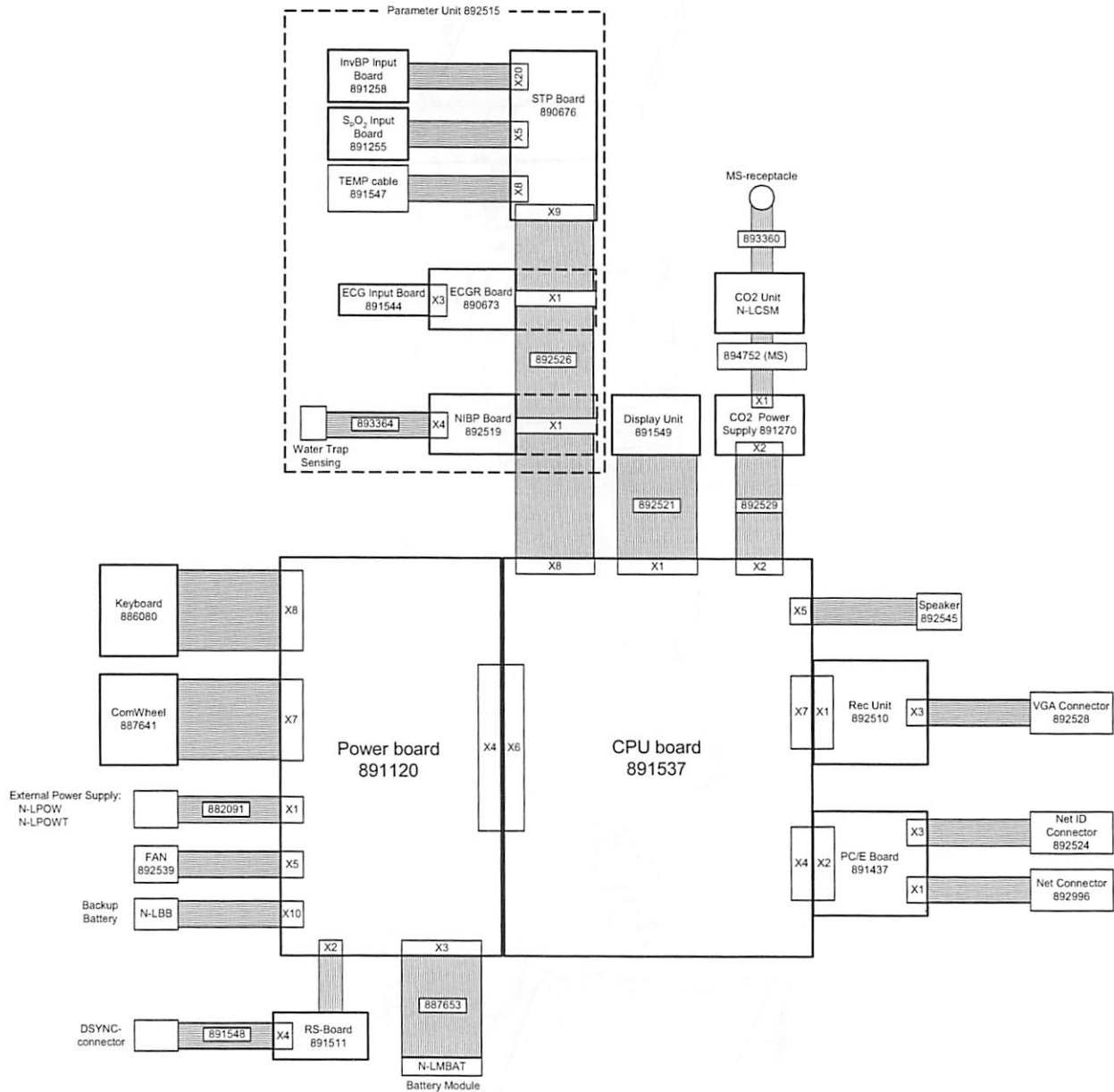
## 2.5 Light External Battery Charger, N-LCHGR (revision 00 and 01)

Item	Item description	Order No
-	Medical power board fuse, 2.5 A	511181 a)
-	LED board	894851 a)
2	Charger board (revision 00)	894789 a)
2	Charger board (revision 01)	896387 a)
9	Fan 5 V DC (revision 00)	896114 a)
9	Fan 12 V DC (revision 01)	896936 a)
15	Chopper power board (Condor)	90480 a)
21	Primary fuses, 2 × T2AH/250 V, 5 × 20 mm	511200 a)

a) The part is recommended for stock



### 3 RIBBON CABLES AND CONNECTORS





**APPENDICES**  
***Installation Guides for***  
***N-LCM, N-LDNET, N-LDATA and N-LNET***

This page intentionally left blank.



**Datex-Ohmeda**

**Optional N-LCM Upgrade for  
S/5™ Light Monitors, F-LM1 and F-LMP1**

**Installation Guide**



All specifications are subject to change without notice.


Document No. 896551-2

November 2000



Datex-Ohmeda, Inc.  
P.O. Box 7550, Madison  
WI 53707-7550, USA  
Tel. +1-608-221-1551  
Fax +1-608-222-9147  
[www.us.datex-ohmeda.com](http://www.us.datex-ohmeda.com)

Datex-Ohmeda Division,  
Instrumentarium Corp.  
P.O. Box 900, FIN-00031  
DATEX-OHMEDA, FINLAND  
Tel. +358 10 394 11 Fax +358 9 146 3310  
[www.datex-ohmeda.com](http://www.datex-ohmeda.com)  
© Instrumentarium Corp. All rights reserved.



## TABLE OF CONTENTS

### Optional N-LCM Upgrade for S/5™ Light Monitors, F-LM1 and F-LMP1

<b>Introduction</b>	<b>1</b>
<b>1 Configuration and tests</b>	<b>3</b>
1.1 Mainstream CO <sub>2</sub> configuration and test.....	3

## TABLE OF FIGURES

Figure 1 Parts.....	4
Figure 2 CO <sub>2</sub> hardware .....	4
Figure 3 Installing the module .....	5
Figure 4 Flex cable.....	5
Figure 5 CO <sub>2</sub> connector .....	6
Figure 6 Flex cable position .....	6
Figure 7 Flex cable and the EMI filter.....	7
Figure 8 Flex cable connection .....	7
Figure 9 Testing the monitor .....	8



## INTRODUCTION

This guide describes how to install the mainstream CO<sub>2</sub> measurement upgrade set for Light Monitors, F-LM1 and F-LMP1. The mainstream CO<sub>2</sub> measurement upgrade set provides mainstream CO<sub>2</sub> measurement capability.

## Installation time

Approximately one to one and a half hour.

## Tools Needed

Cross head screwdriver and pliers.

## Parts Needed

891133	Patient connector plate	1 pc
891134	Patient connector plate	1 pc
893373	Co2/mainstream assembly	1 pc
304511	EMI-filter (ferrite ring for flat cable)	1 pc
617210	Cross cyl.-head screw M3x6 tufflock	3 pc
640445	Insulate nylonpost, 13x6.5, M3 Male/Female	1 pc
902401	Flex cable	1 pc
	Connector panel, F-LM1	1 pc
	Connector panel, F-LMP1	1 pc
628703	Cross cyl. Head screw M3x10 tufflock	2 pc

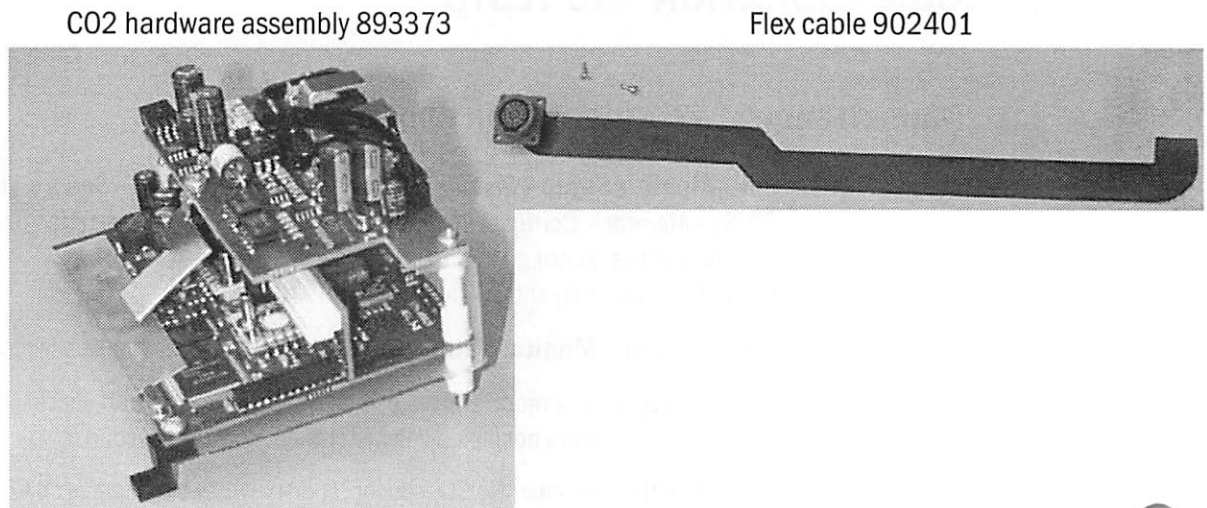


# 1 CONFIGURATION AND TESTS

## 1.1 Mainstream CO<sub>2</sub> configuration and test

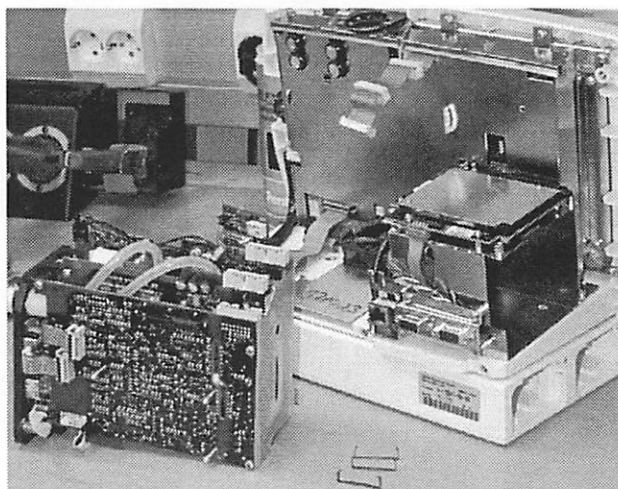
1. Enter **Monitor Setup - Install/Service** (password 16-4-34) - **Service View** (password 26-23-8) - **Monitor - Configuration**. Choose the correct set configuration related to the monitor hardware configuration. Perform factory reset.  
NOTE: MS + SS - CO<sub>2</sub> should always be set to **NO**.
2. Set time & date (**Monitor Setup - Set Time and Date**) and make user configurations.
3. Enter the CO<sub>2</sub> service menu and check that the "Timeouts", "Bad checksums" and "send queue full" values are not increasing faster than by 50 per second.
4. Check that the message "No CO<sub>2</sub> sensor" is displayed when there is no CO<sub>2</sub> sensor connected. Connect a CO<sub>2</sub> sensor to the monitor and check that the message "warming" is displayed.
5. Wait until the "warming" message disappears and the CO<sub>2</sub> value appears to the screen. Breathe at least 5 times to the CO<sub>2</sub> sensor adapter and make sure that the measured values are reasonable and the Respiratory value is calculated.
6. Perform the CO<sub>2</sub> calibration check.





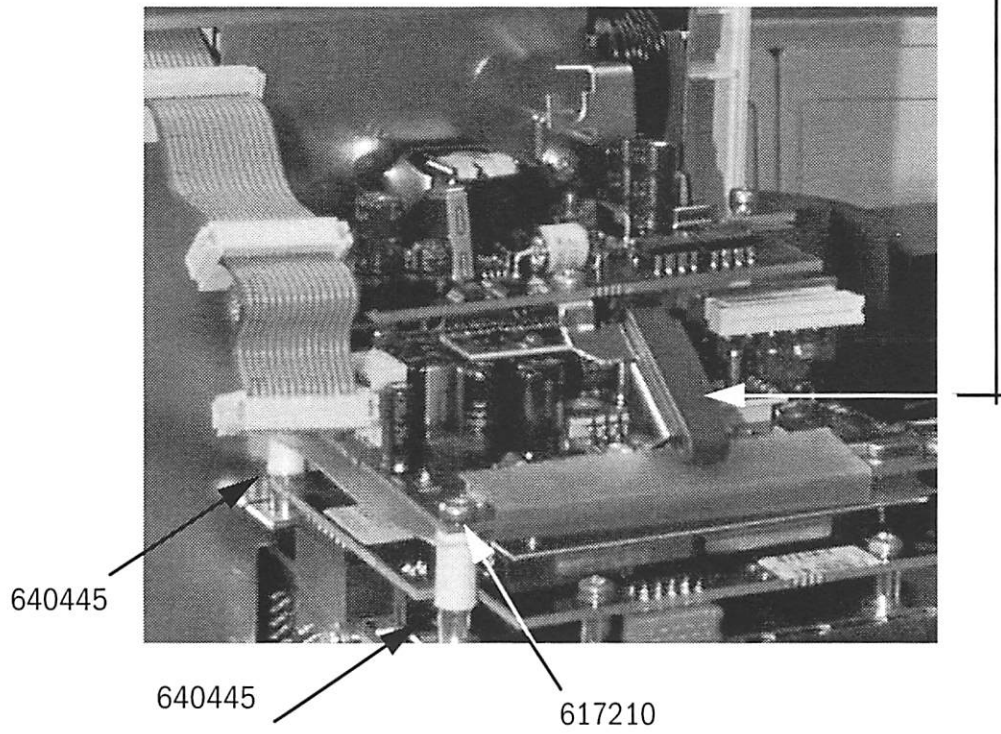
**Figure 1**      **Parts**

The CO2 hardware is installed on top of the recorder housing. The NESTPR-module has to be removed for cabling to the patient connector plate.



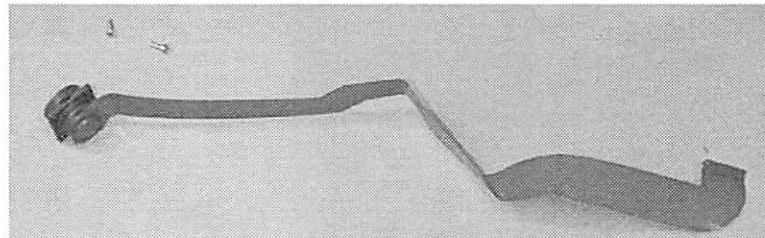
**Figure 2**      **CO<sub>2</sub> hardware**

Install the module using the bushings and screws. Put the EMI filter on its holder.



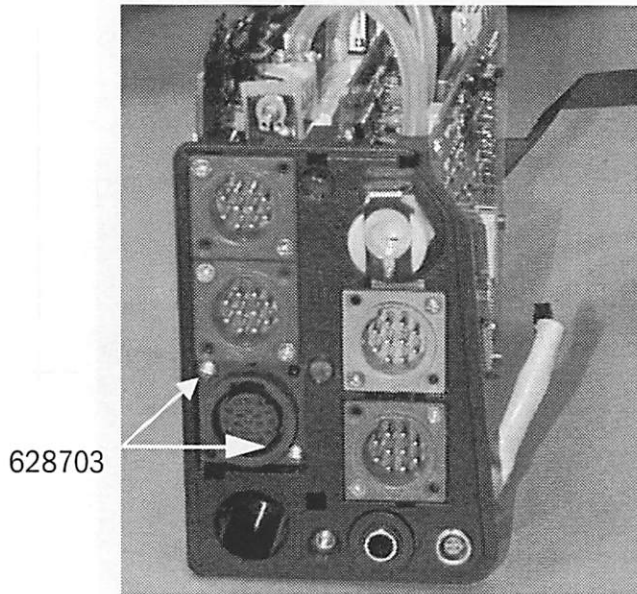
**Figure 3**      **Installing the module**

On the flex cable are marks where to bend the cable



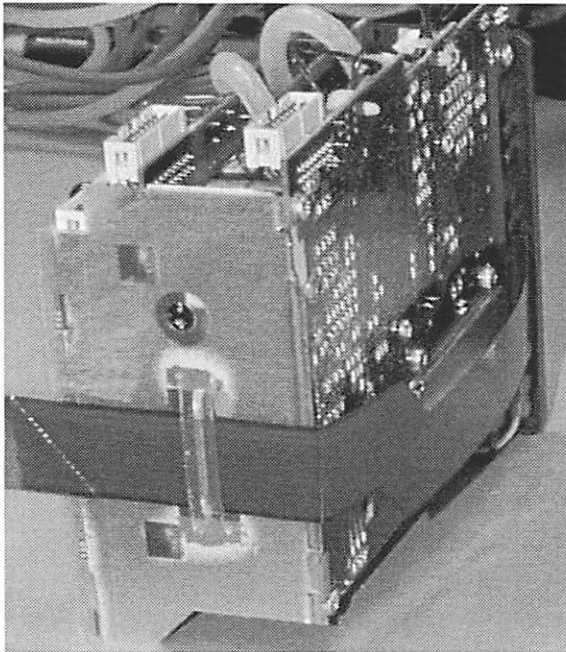
**Figure 4**      **Flex cable**

Fasten the CO2 connector with the two screws provided in the kit



**Figure 5** CO<sub>2</sub> connector

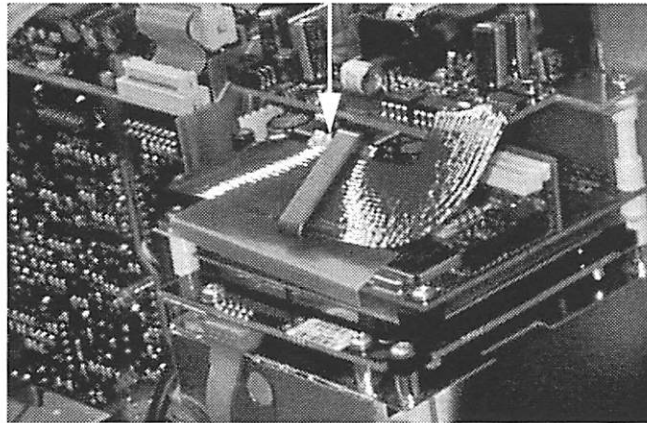
Put the flex cable according to the picture



**Figure 6** Flex cable position

Put the flex cable through the EMI filter.

Note: Work very carefully with the flex cable which breaks easily

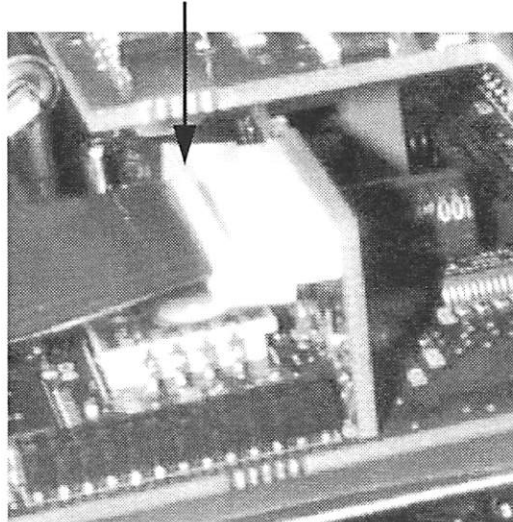


**Figure 7** Flex cable and the EMI filter

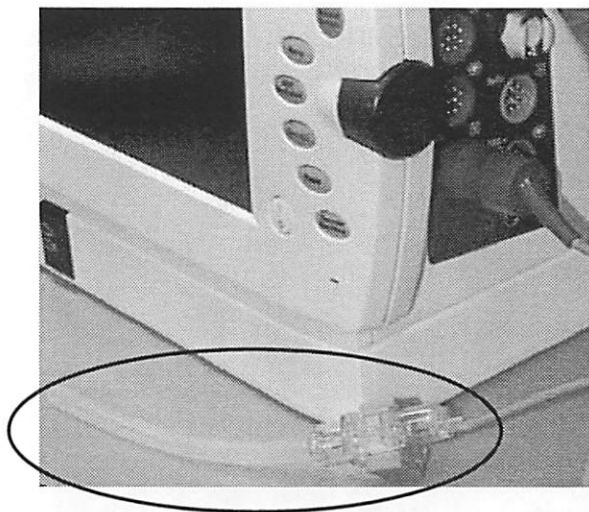
Pull out the locking piece before pushing the flex cable into the connector.

After pushing the flex cable into the connector push the lock piece back.

The flex cable does not make a contact with the connector if the lock piece is loose



**Figure 8** Flex cable connection



Test the monitor using Main Stream sensor and Calibration Check Adapter with 5% CO<sub>2</sub>.

**Figure 9**      **Testing the monitor**

**Datex-Ohmeda**

**Optional N-LDNET Upgrade for  
S/5™ Light Monitors, F-LM1 and F-LMP1**

**Installation Guide**

All specifications are subject to change without notice.

Document No. 896552-2

November 2000

Datex-Ohmeda, Inc.  
P.O. Box 7550, Madison  
WI 53707-7550, USA  
Tel. +1-608-221-1551  
Fax +1-608-222-9147  
[www.us.datex-ohmeda.com](http://www.us.datex-ohmeda.com)

Datex-Ohmeda Division,  
Instrumentarium Corp.  
P.O. Box 900, FIN-00031  
DATEX-OHMEDA, FINLAND  
Tel. +358 10 394 11 Fax +358 9 146 3310  
[www.datex-ohmeda.com](http://www.datex-ohmeda.com)  
© Instrumentarium Corp. All rights reserved.

---

# TABLE OF CONTENTS

## Optional N-LDNET Upgrade for S/5™ Light Monitors, F-LM1 and F-LMP1

<b>TABLE OF CONTENTS</b>	<b>i</b>
<b>TABLE OF FIGURES</b>	<b>i</b>
<b>Introduction</b>	<b>1</b>
<b>1 Configuration and tests</b>	<b>3</b>
1.1 Network and DataCard configuration and test .....	3
1.2 Network Test.....	3
1.3 DataCard Test.....	3

## TABLE OF FIGURES

Figure 1	Parts.....	4
Figure 2	Three different PC/Ethernet boards.....	4
Figure 3	Data card hardware is installed on top of the recorder housing.....	5
Figure 4	Fasten the Ethernet cable with connector and the ID cable with connector on the metal plate.....	5
Figure 5	Lift the rear of the board before pushing the connector in.....	6
Figure 6	Remove the cover plate and install the new one with the hole .....	6
Figure 7	Only Data card, not menu card allowed.....	7





## INTRODUCTION

This guide describes how to install the DataCard & Network upgrade set for Light Monitors, F-LM1 and F-LMP1. The DataCard & Network upgrade set provides patient trend data collection to Datex-Ohmeda PCMCIA MemCard and Network connection to Datex-Ohmeda information centre. With the DataCard, the patient trend data collected with the Light Monitor can be transferred to other S/5 monitors. The Network permits central monitoring functions and printing services.

## Installation time

Approximately 30 minutes to one hour.

## Tools Needed

Cross head screwdriver.

## Parts Needed

617120	Cross cylinder screw	2pcs
617210	Cross cylinder screw	3pcs
892523	Ethernet cable	1 pc
892524	ID cable	1 pc
892996	Connector board	1 pc
894698	Ethernet board	1 pc
617210	Cross cvl. Head screw M3x6 tufflock	1 pc
887045	Data MemCard	1 pc
893310	Cover plate	1 pc
894697	PC board	1 pc




# 1 CONFIGURATION AND TESTS

## 1.1 Network and DataCard configuration and test

1. Enter **Monitor Setup - Install/Service** (password 16-4-34) - **Service View** (password 26-23-8) - **Monitor - Configuration**. Choose the NET and DataCard configurations **YES**. Perform factory reset.
2. Set time & date (**Monitor Setup - Set Time and Date**) and make user configurations.

## 1.2 Network Test

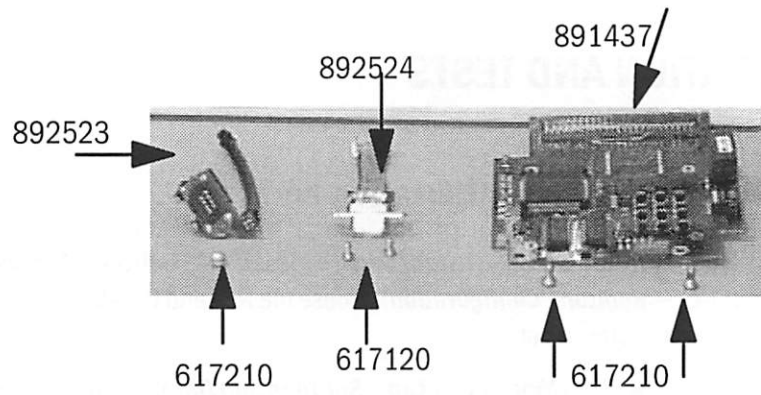
3. Check that the monitor connects to the Datex-Ohmeda Network, i.e. the network symbol  is displayed on the upper right-hand corner of the screen.

A message regarding the connection to Datex-Ohmeda Central should appear in the message field on the screen.

4. Check in the **Monitor - Communication** service menu that:
  - The "location ID number" matches with the ID plug connected to X3
  - The packets and bytes IN are increasing slowly
  - The packets and bytes OUT are increasing fast
  - "connections" shows the names of the connected networks
  - The counters for data errors ("CRC", "Frame", "Transm.") are stable  
NOTE: The counters may show values greater than 0. However, any values increasing continuously indicate a problem.
5. Check that the counters for hardware errors ("Intern.", "Missed", "FIFO", "Overrun") all show 0.

## 1.3 DataCard Test

6. Insert a DataCard labeled "Data" in the DataCard slot. Check that the message "Data Card inserted" appears onto the message field and the DataCard symbol is displayed on the upper right-hand corner of the monitor.

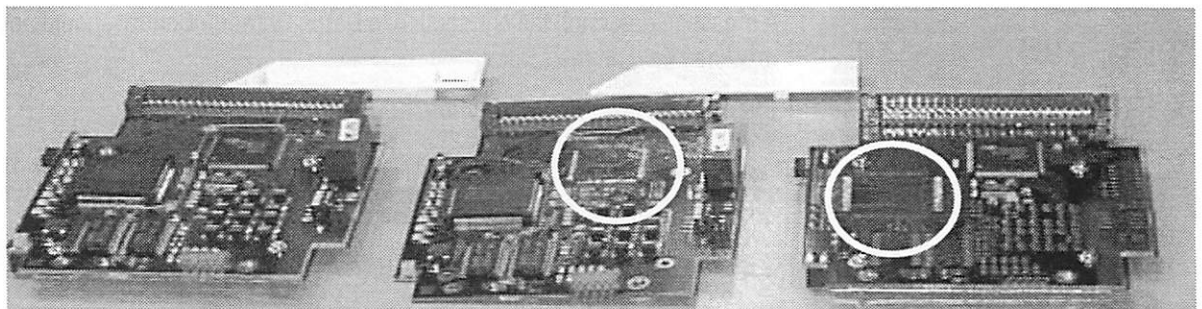


**Figure 1**      **Parts**

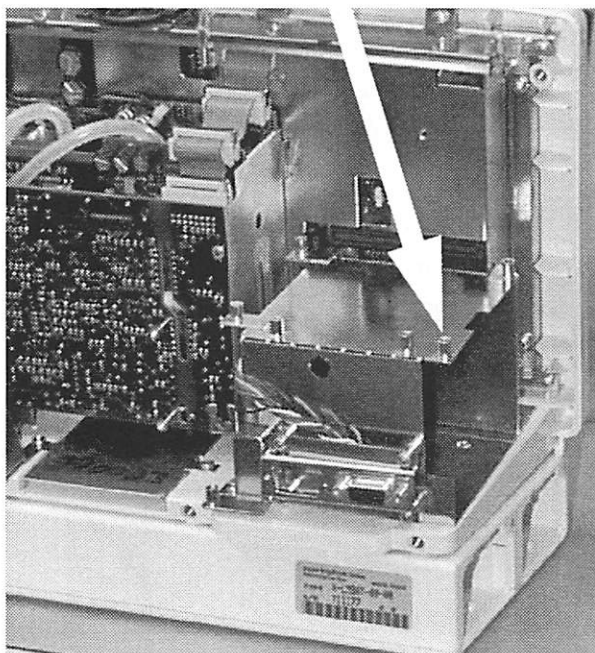
NET and Data

NET

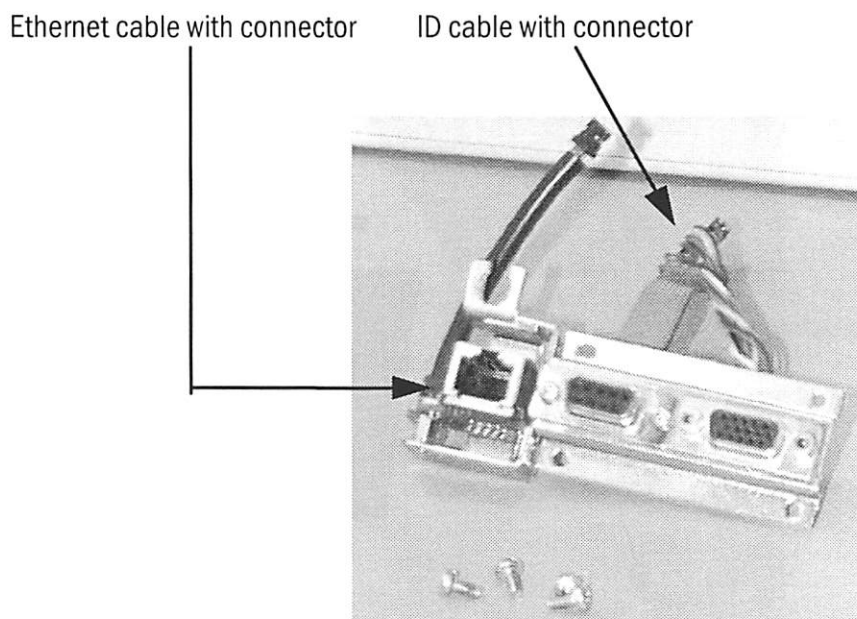
Data



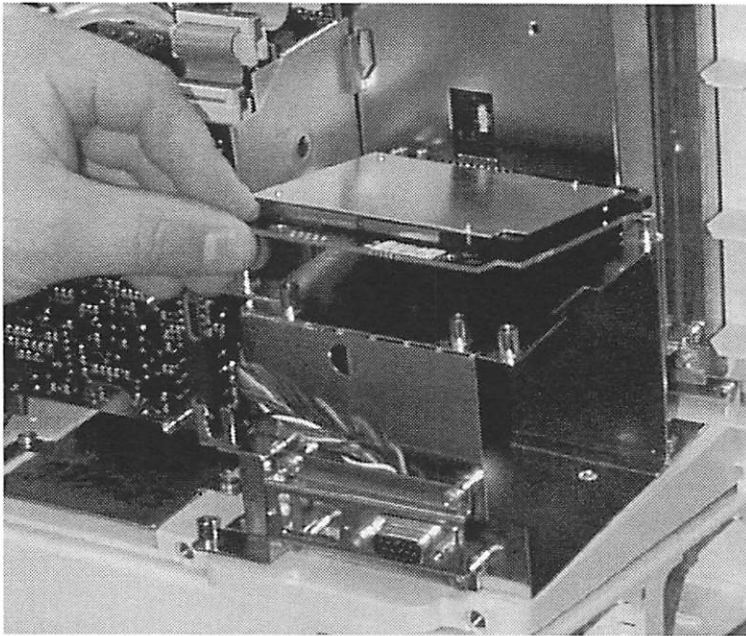
**Figure 2**      **Three different PC/Ethernet boards**



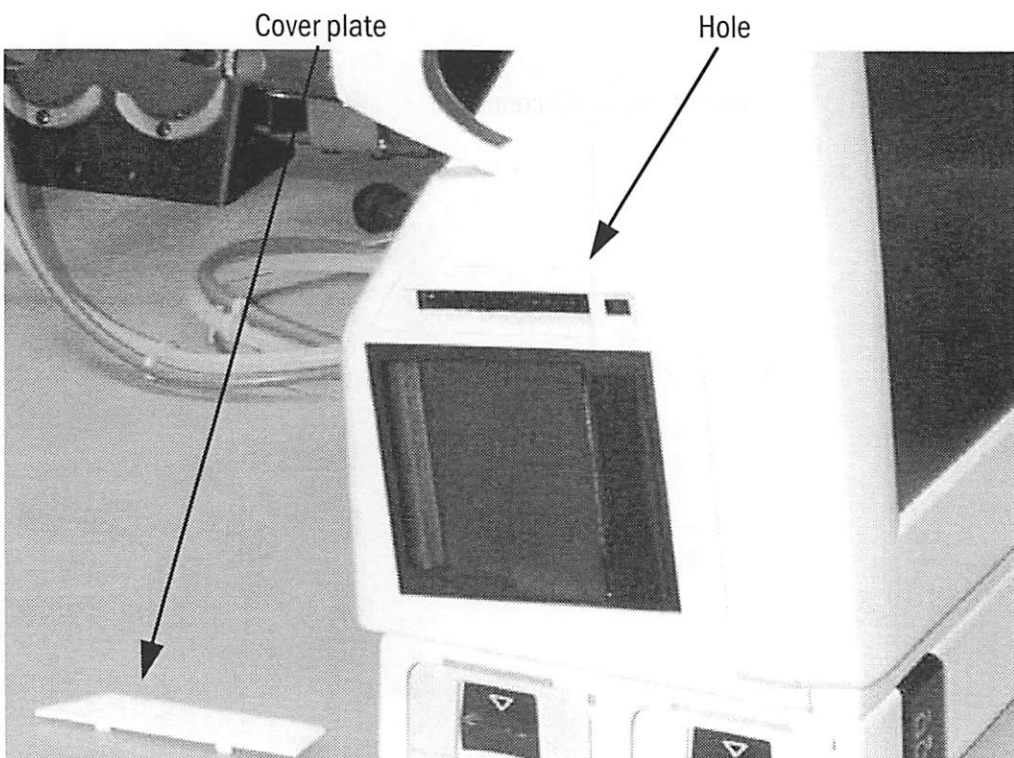
**Figure 3** Data card hardware is installed on top of the recorder housing.



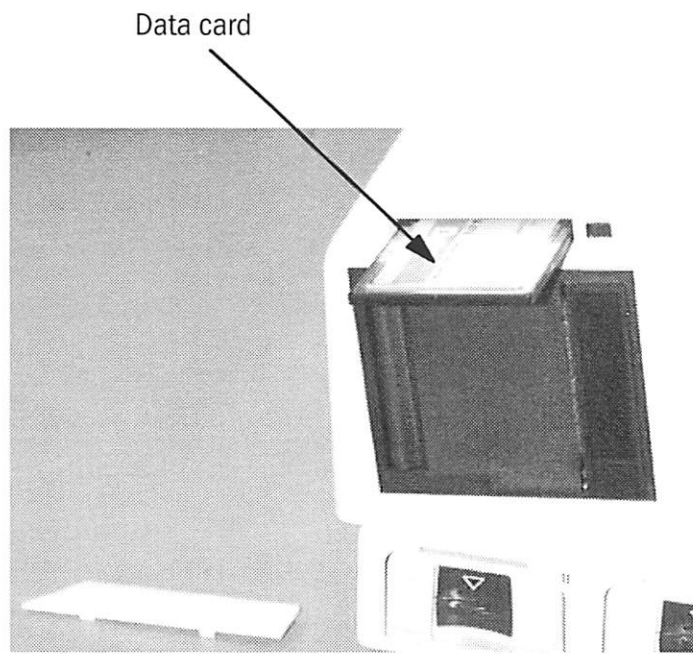
**Figure 4** Fasten the Ethernet cable with connector and the ID cable with connector on the metal plate



**Figure 5** Lift the rear of the board before pushing the connector in



**Figure 6** Remove the cover plate and install the new one with the hole



**Figure 7**      **Only Data card, not menu card allowed**





**Datex-Ohmeda**

**Optional N-LDATA Upgrade for  
S/5™ Light Monitors, F-LM1 and F-LMP1**

**Installation Guide**

**CE**  
0537

All specifications are subject to change without notice.

Document No.896553-2

November 2000

Datex-Ohmeda, Inc.  
P.O. Box 7550, Madison  
WI 53707-7550, USA  
Tel. +1-608-221-1551  
Fax +1-608-222-9147  
[www.us.datex-ohmeda.com](http://www.us.datex-ohmeda.com)

Datex-Ohmeda Division,  
Instrumentarium Corp.  
P.O. Box 900, FIN-00031  
DATEX-OHMEDA, FINLAND  
Tel. +358 10 394 11 Fax +358 9 146 3310  
[www.datex-ohmeda.com](http://www.datex-ohmeda.com)  
© Instrumentarium Corp. All rights reserved.

---

# TABLE OF CONTENTS

## Optional N-LDATA Upgrade for S/5™ Light Monitors, F-LM1 and F-LMP1

<b>TABLE OF CONTENTS</b>	<b>i</b>
<b>TABLE OF FIGURES</b>	<b>i</b>
<b>1 Introduction</b>	<b>1</b>

## TABLE OF FIGURES

Figure 1 Parts.....	2
Figure 2 Three Ethernet boards.....	2
Figure 3 Installing Data card hardware.....	3
Figure 4 Installing the board.....	3
Figure 5 Replacing the cover plate.....	4
Figure 6 Data card insterted .....	4



# 1 INTRODUCTION

This guide describes how to install the DataCard upgrade set for Light Monitors, F-LM1 and F-LMP1. The DataCard upgrade set provides patient trend data collection to Datex-Ohmeda PCMCIA MemCard. With the DataCard, the patient trend data collected with the Light Monitor can be transferred to other S/5 monitors.

## Installation time

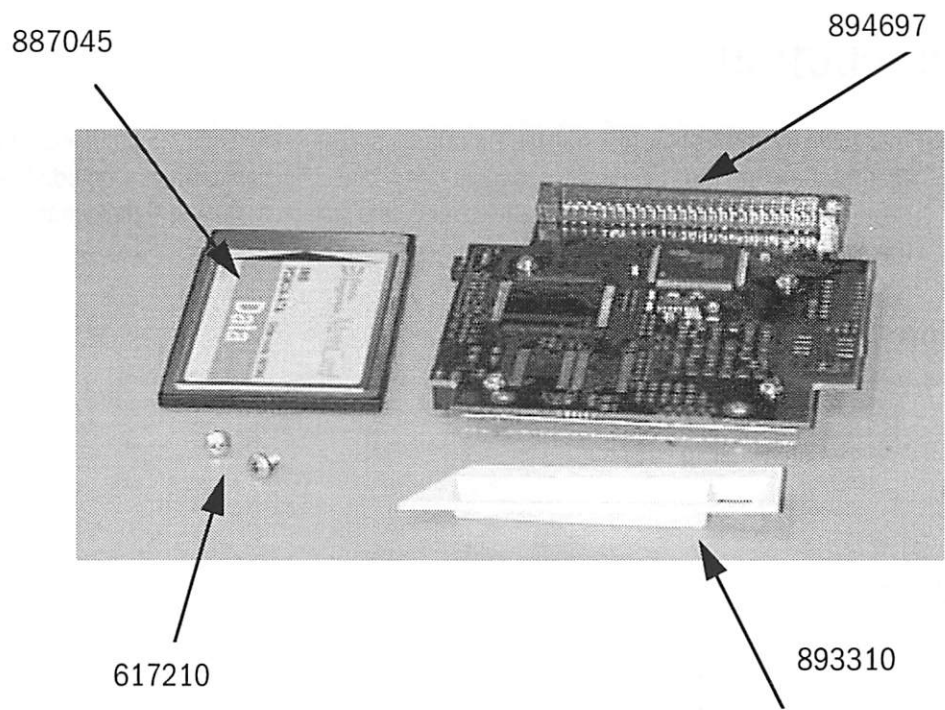
Approximately half to one hour.

## Tools Needed

Cross head screwdriver .

## Parts Needed

617210	Cross cyl. head screw M3x6 tufflock	2pcs
887045	Data MemCard	1pc
893310	Cover plate	1pc
894697	PC board	1pc



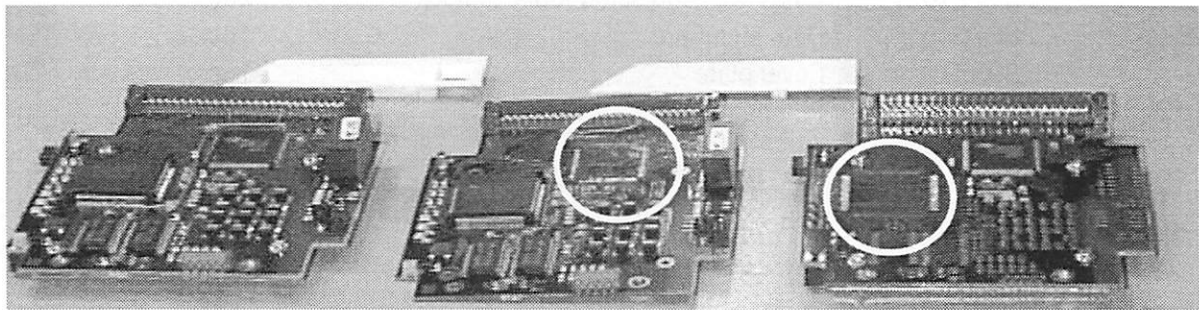
**Figure 1**      **Parts**

Three different PC/Ethernet boards:

NET and Data

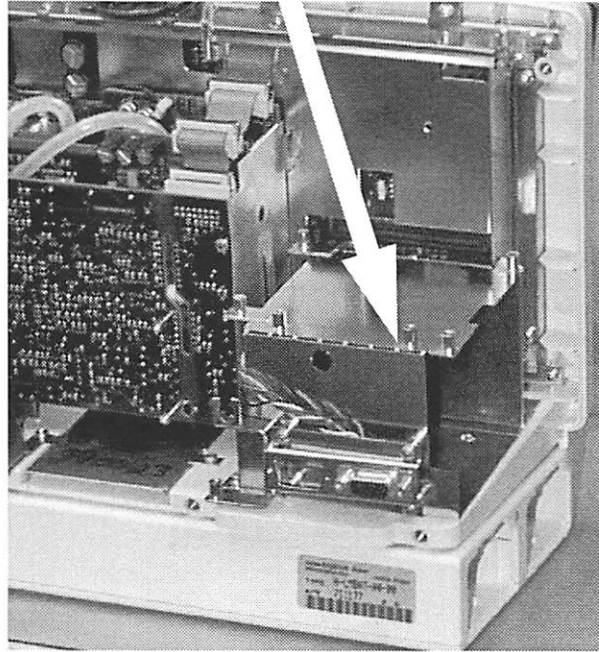
NET

Data



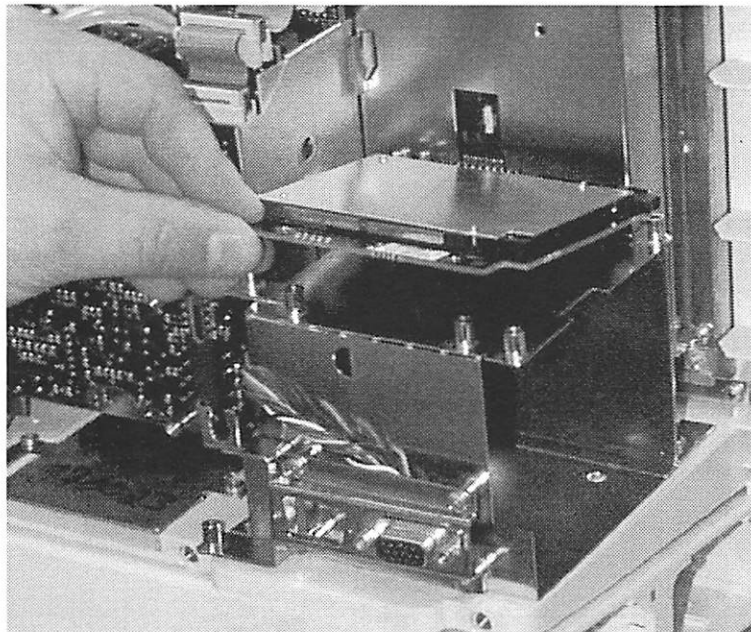
**Figure 2**      **Three Ethernet boards**

Data card hardware is installed on top of the recorder housing.



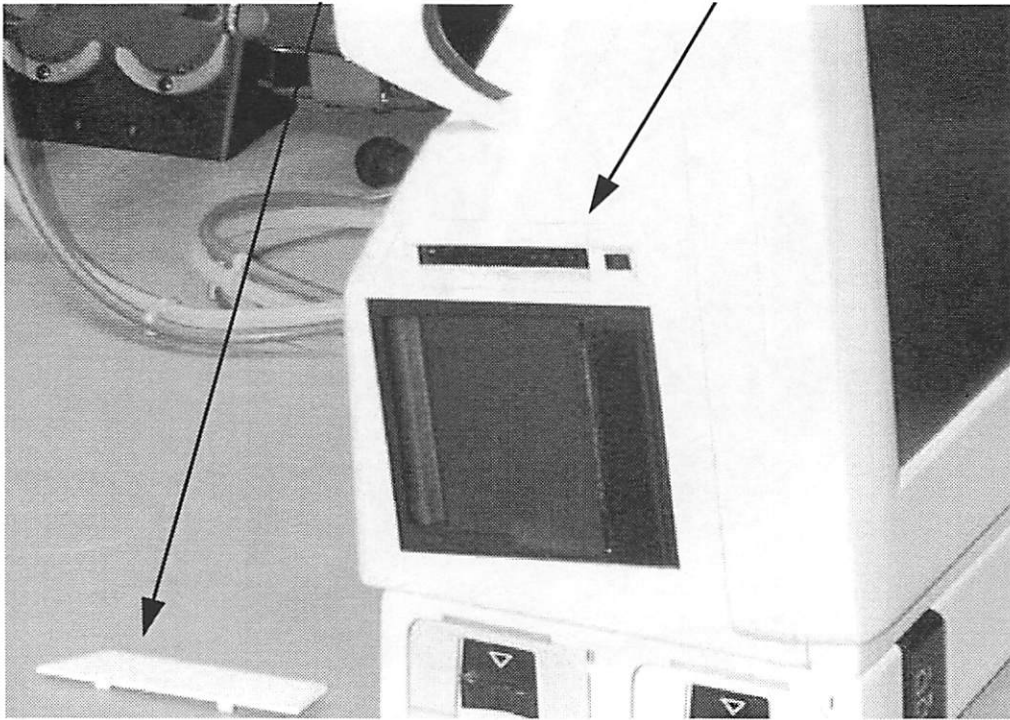
**Figure 3**      **Installing Data card hardware**

Lift the rear of the board before pushing the connector in



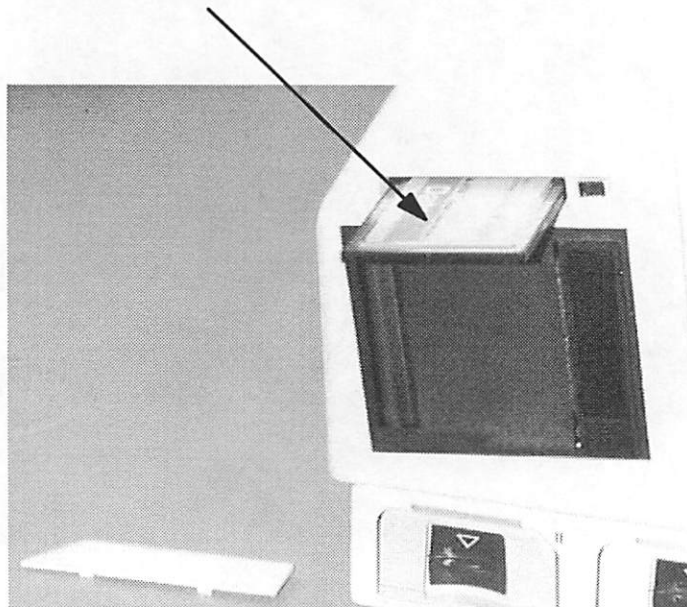
**Figure 4**      **Installing the board**

Remove the cover plate and install the new one with the hole



**Figure 5** Replacing the cover plate

Note: Only Data card, not Menu card allowed



**Figure 6** Data card inserted

**Datex-Ohmeda**

**Optional N-LNET Upgrade for  
S/5™ Light Monitors, F-LM1 and F-LMP1**

**Installation Guide**



All specifications are subject to change without notice.

Document No. 896554-2

November 2000

Datex-Ohmeda, Inc.  
P.O. Box 7550, Madison  
WI 53707-7550, USA  
Tel. +1-608-221-1551  
Fax +1-608-222-9147  
[www.us.datex-ohmeda.com](http://www.us.datex-ohmeda.com)

Datex-Ohmeda Division,  
Instrumentarium Corp.  
P.O. Box 900, FIN-00031  
DATEX-OHMEDA, FINLAND  
Tel. +358 10 394 11 Fax +358 9 146 3310  
[www.datex-ohmeda.com](http://www.datex-ohmeda.com)  
© Instrumentarium Corp. All rights reserved.



---

# TABLE OF CONTENTS

## Optional N-LNET Upgrade for Light Monitors, F-LM1, F-LMP1 S/5™ Light Monitors, F-LM1 and F-LMP1

<b>TABLE OF CONTENTS</b>	<b>i</b>
<b>1 Introduction</b>	<b>1</b>

# TABLE OF CONTENTS

Figure 1 Parts .....	2
Figure 2 Three different PC/Ethernet boards:.....	2
Figure 3 Installing Network hardware .....	3
Figure 4 Fastening Ethernet cable.....	3
Figure 5 Placing the Ethernet board .....	4
Figure 6 Upgrade completed .....	4



# 1 INTRODUCTION

This guide describes how to install the Network upgrade set for S/5 Light Monitors, F-LM1 and F-LMP1. The Network upgrade set provides network connection to Datex-Ohmeda information centre for central monitoring functions and printing services.

## Installation time

Approximately half to one hour.

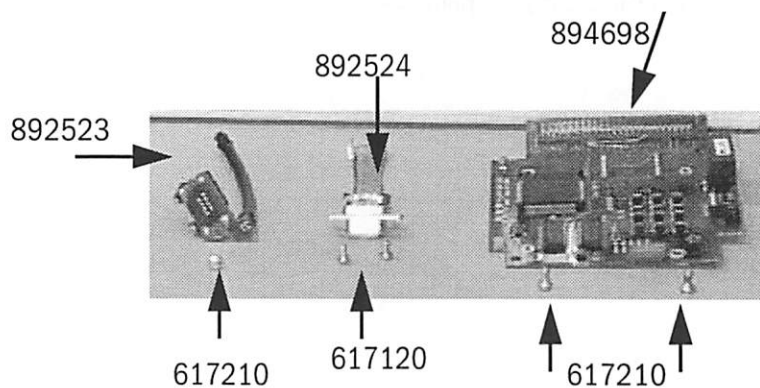
## Tools Needed

Cross head screwdriver .

## Parts Needed

### Parts needed:

617120	Cross cylinder screw	2pcs
617210	Cross cylinder screw	3pcs
892523	Ethernet cable	1pc
892524	ID Cable	1pc
892996	Connector board	1pc
894698	Ethernet board	1pc

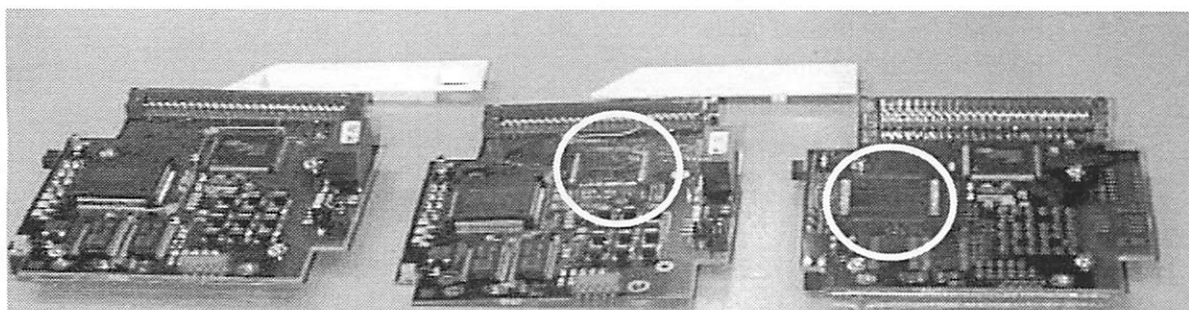


**Figure 1**      **Parts**

NET and Data

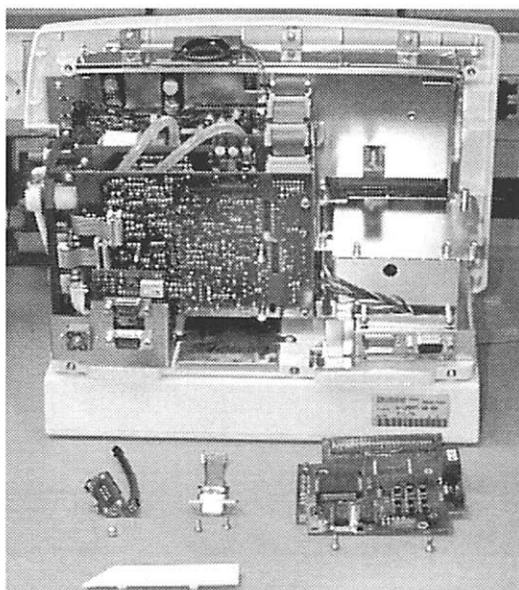
NET

Data



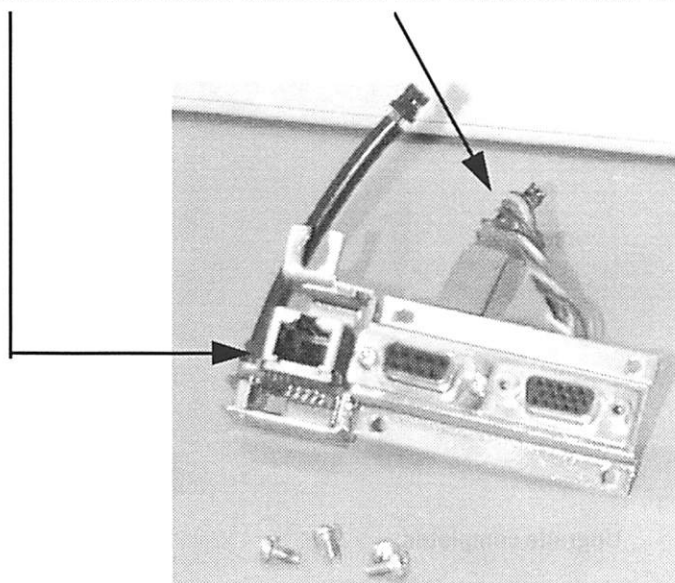
**Figure 2**      **Three different PC/Ethernet boards:**

The network hardware is to be installed on top of the recorder housing.



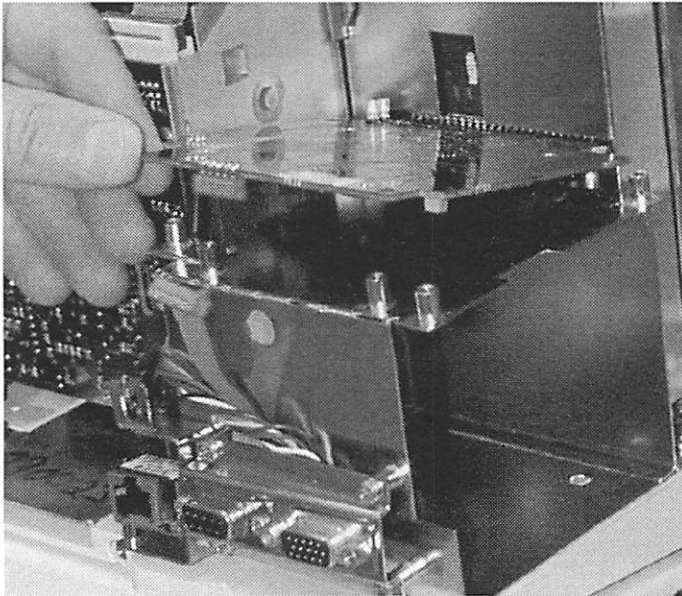
**Figure 3** Installing Network hardware

Fasten the Ethernet cable with connector and ID cable with connector on the metal plate.



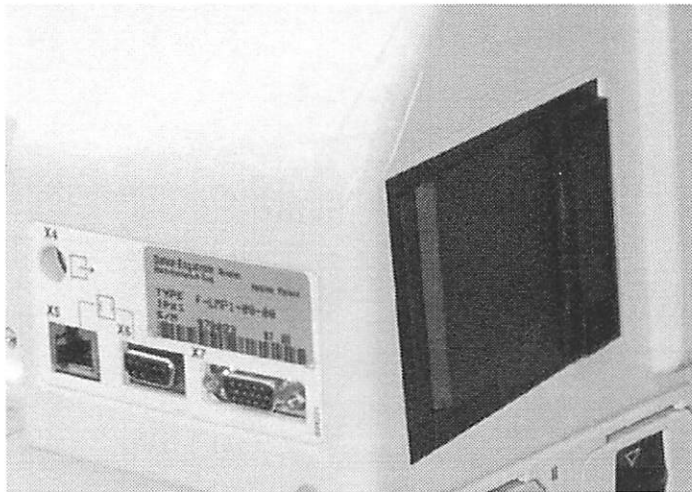
**Figure 4** Fastening Ethernet cable

Lift the rear end of the Ethernet board when pushing the board into the connector.



**Figure 5**      **Placing the Ethernet board**

After completing the upgrade:



**Figure 6**      **Upgrade completed**