

MX2/RX CompoNet Option Board

Model: 3G3AX-MX2-CRT-E
3G3AX-RX-CRT-E

USER'S MANUAL



OMRON

Notice:

OMRON products are manufactured for use according to proper procedures by a qualified operator and only for the purposes described in this manual.

The following conventions are used to indicate and classify precautions in this manual. Always heed the information provided with them. Failure to heed precautions can result in injury to people or damage to property.

OMRON Product References

All OMRON products are capitalized in this manual. The word "Unit" is also capitalized when it refers to an OMRON product, regardless of whether or not it appears in the proper name of the product.

Trademarks and Copyrights

Other product names and company names in this manual are trademarks or registered trademarks of their respective companies.

The copyright of the 3G3AX-MX2-CRT-E and 3G3AX-RX-CRT-E Option Boards belong to OMRON Corporation.

Intended Audience

This manual is intended for the following personnel, who must also have knowledge of electrical systems (an electrical engineer or the equivalent).

- Personnel in charge of installing FA systems.
- Personnel in charge of designing FA systems.
- Personnel in charge of managing FA systems and facilities.
- Personnel in charge of maintaining FA systems.

© OMRON, 2011

All rights reserved. No part of this publication may be reproduced, stored in a retrieval system, or transmitted, in any form, or by any means, mechanical, electronic, photocopying, recording, or otherwise, without the prior written permission of OMRON.

No patent liability is assumed with respect to the use of the information contained herein. Moreover, because OMRON is constantly striving to improve its high-quality products, the information contained in this manual is subject to change without notice. Every precaution has been taken in the preparation of this manual. Nevertheless, OMRON assumes no responsibility for errors or omissions. Neither is any liability assumed for damages resulting from the use of the information contained in this publication.

About this Manual

This manual describes the:

- 3G3AX-MX2-CRT-E CompoNet Option Board for OMRON's MX2 Inverter
- 3G3AX-RX-CRT-E CompoNet Option Board for OMRON's RX Inverter

It also describes how to install and operate the Units.

Please read this manual carefully so that you understand the information provided before installing or using the Option Board. Start with the precautions in the following section. They describe the operating environment and application safety measures which must be observed prior to and when using the Option Board.

For the remainder of this manual, both the 3G3AX-MX2-CRT-E CompoNet Option Board as the 3G3AX-RX-CRT-E CompoNet Option Board will be referred as Option Board or Unit. The MX2 and RX Inverters will be referred as Inverter.

In case information is especially for the MX2 or for the RX Inverter, a clear notification will be included for which the note is meant.

If information especially is meant for the MX2, this symbol is shown: 

If information especially is meant for the RX, this symbol is shown: 

Please be sure to read the related user manuals to use the Option Board safely and properly. Be sure you are using the most current version of the manual:

Manual	Contents	Cat No.
MX2 User's Manual	Describes the installation and operation of the MX2 Inverter	I570
RX User's Manual	Describes the installation and operation of the RX Inverter	I560
CS/CJ Series CompoNet Master Units Operation Manual	Provides an overview of CompoNet Networks, communications specifications, wiring methods, and CompoNet Master Unit functions.	W456

Warranty and Limitations of Liability

WARRANTY

OMRON's exclusive warranty is that the products are free from defects in materials and workmanship for a period of one year (or other period if specified) from date of sale by OMRON.

OMRON MAKES NO WARRANTY OR REPRESENTATION, EXPRESS OR IMPLIED, REGARDING NONINFRINGEMENT, MERCHANTABILITY, OR FITNESS FOR PARTICULAR PURPOSE OF THE PRODUCTS. ANY BUYER OR USER ACKNOWLEDGES THAT THE BUYER OR USER ALONE HAS DETERMINED THAT THE PRODUCTS WILL SUITABLY MEET THE REQUIREMENTS OF THEIR INTENDED USE. OMRON DISCLAIMS ALL OTHER WARRANTIES, EXPRESS OR IMPLIED.

LIMITATIONS OF LIABILITY

OMRON SHALL NOT BE RESPONSIBLE FOR SPECIAL, INDIRECT, OR CONSEQUENTIAL DAMAGES, LOSS OF PROFITS OR COMMERCIAL LOSS IN ANY WAY CONNECTED WITH THE PRODUCTS, WHETHER SUCH CLAIM IS BASED ON CONTRACT, WARRANTY, NEGLIGENCE, OR STRICT LIABILITY.

In no event shall the responsibility of OMRON for any act exceed the individual price of the product on which liability is asserted.

IN NO EVENT SHALL OMRON BE RESPONSIBLE FOR WARRANTY, REPAIR, OR OTHER CLAIMS REGARDING THE PRODUCTS UNLESS OMRON'S ANALYSIS CONFIRMS THAT THE PRODUCTS WERE PROPERLY HANDLED, STORED, INSTALLED, AND MAINTAINED AND NOT SUBJECT TO CONTAMINATION, ABUSE, MISUSE, OR INAPPROPRIATE MODIFICATION OR REPAIR.

Application Considerations

SUITABILITY FOR USE

OMRON shall not be responsible for conformity with any standards, codes, or regulations that apply to the combination of products in the customer's application or use of the products.

At the customer's request, OMRON will provide applicable third party certification documents identifying ratings and limitations of use that apply to the products. This information by itself is not sufficient for a complete determination of the suitability of the products in combination with the end product, machine, system, or other application or use.

The following are some examples of applications for which particular attention must be given. This is not intended to be an exhaustive list of all possible uses of the products, nor is it intended to imply that the uses listed may be suitable for the products:

- o Outdoor use, uses involving potential chemical contamination or electrical interference, or conditions or uses not described in this manual.
- o Nuclear energy control systems, combustion systems, railroad systems, aviation systems, medical equipment, amusement machines, vehicles, safety equipment, and installations subject to separate industry or government regulations.
- o Systems, machines, and equipment that could present a risk to life or property.

Please know and observe all prohibitions of use applicable to the products.

NEVER USE THE PRODUCTS FOR AN APPLICATION INVOLVING SERIOUS RISK TO LIFE OR PROPERTY WITHOUT ENSURING THAT THE SYSTEM AS A WHOLE HAS BEEN DESIGNED TO ADDRESS THE RISKS, AND THAT THE OMRON PRODUCTS ARE PROPERLY RATED AND INSTALLED FOR THE INTENDED USE WITHIN THE OVERALL EQUIPMENT OR SYSTEM.

Disclaimers

PROGRAMMABLE PRODUCTS

OMRON shall not be responsible for the user's programming of a programmable product, or any consequence thereof.

CHANGE IN SPECIFICATIONS

Product specifications and accessories may be changed at any time based on improvements and other reasons. It is our practice to change model numbers when published ratings or features are changed, or when significant construction changes are made. However, some specifications of the products may be changed without any notice. When in doubt, special model numbers may be assigned to fix or establish key specifications for your application on your request. Please consult with your OMRON representative at any time to confirm actual specifications of purchased products.

DIMENSIONS AND WEIGHTS

Dimensions and weights are nominal and are not to be used for manufacturing purposes, even when tolerances are shown.

PERFORMANCE DATA

Performance data given in this manual is provided as a guide for the user in determining suitability and does not constitute a warranty. It may represent the result of OMRON's test conditions, and the users must correlate it to actual application requirements. Actual performance is subject to the OMRON Warranty and Limitations of Liability.

ERRORS AND OMISSIONS

The information in this manual has been carefully checked and is believed to be accurate; however, no responsibility is assumed for clerical, typographical, or proof-reading errors, or omissions.

Table of contents

Safety Messages	ix
1 Hazardous High Voltage	ix
2 General Precautions - Read These First!	x
3 Installation Precautions	xi
4 Configuration Precautions	xi
5 Application Precautions	xii
6 Operating Environment Precautions	xiii
7 Handling, Storage and Disposal	xiii
8 Compliance with EC Directives	xiii
SECTION 1	
Getting Started	1
1-1 Introduction	1
1-2 Option Board Specifications	3
1-3 Introduction to CompoNet	5
SECTION 2	
Option Board Mounting and Installation	7
2-1 Orientation to Option Board Features	7
2-2 Basic System Description	10
2-3 How to mount the Option Board on the Inverter	11
SECTION 3	
Configuring Drive Parameters and Option Board	23
3-1 Installation of EDS files	23
3-2 Configuring the Option Board	23
3-3 Configuring the Network	27
3-4 Registration table	27
SECTION 4	
Operations and Monitoring	29
4-1 Setting up inverter	29
4-2 Operating the Motor	30
4-3 Overriding Inverter inputs	31
4-4 Controlling Inverter Torque	32
4-5 Faults and Trips	33
4-6 Accessing Parameters	34
4-7 Flexible Format	35
4-8 Limitations Caused by Inverter Mode and Rating Selection	38
SECTION 5	
Troubleshooting and Maintenance	39
5-1 Troubleshooting Using the LED Indicators	39
5-2 Other Error Causes and Error Procedures	44
5-3 Maintenance and Inspection	45
APPENDIX A	
Glossary	53

APPENDIX B

Assembly Specification	55
B-1 Basic Speed Control IO (20/70)	55
B-2 Extended Speed Control IO (21/71)	57
B-3 Extended Speed and Torque Control IO (123/173)	59
B-4 Special IO (100/150)	61
B-5 Extended Control IO (101/151/153)	63
B-6 Extended Speed and Acceleration Control IO (110/111)	66

APPENDIX C

General Object Specification	69
C-1 Identity Object (Class 0x01)	69
C-2 Message Router Object (Class 0x02)	72
C-3 Assembly Object (Class 0x04)	73
C-4 Connection Object (Class 0x05)	74
C-5 Discrete Input Point Object (Class 0x08)	75
C-6 Discrete Output Point Object (Class 0x09)	75
C-7 Unit Parameter Object (Class 0x94)	76
C-8 CompoNet Link Object (Class 0xF7)	76

APPENDIX D

AC Drive Object Specification	77
D-1 Motor Data Object (Class 0x28)	77
D-2 Control Supervisor Object (Class 0x29)	78
D-3 AC/DC Drive Object (Class 0x2A)	81

APPENDIX E

CompoNet Explicit Messages	83
E-1 Basic Format of Explicit Messages	83
E-2 Function Code Object (Class 0x65)	85
E-3 Modbus Register Object (Class 0x64)	87
E-4 Explicit Message Error Codes	89

APPENDIX F

Flexible Format	91
Table index	93
Revision history	96

Safety Messages

For the best results with the Inverter, carefully read this manual and all of the warning labels attached to the Inverter before installing and operating it, and follow the instructions exactly. Keep this manual handy for quick reference.

Definitions and Symbols

A safety instruction (message) includes a "Safety Alert Symbol" and a signal word or phrase such as WARNING or CAUTION. Each signal word has the following meaning:

 **Caution** Indicates a potentially hazardous situation which, if not avoided, could result in electric shock. It calls your attention to items or operations that could be dangerous to you and other persons operating this equipment.

Read the message and follow the instructions carefully.

 **WARNING** Indicates a potentially hazardous situation which, if not avoided, could result in death or serious injury. Additionally, there may be severe property damage.

 **Caution** Indicates a potentially hazardous situation, which, if not avoided, may result in minor or moderate injury, or property damage.

Step 1 Indicates a step in a series of action steps required to accomplish a goal. The number of the step will be contained in the step symbol.

Note Notes indicate an area or subject of special merit, emphasizing either the product's capability or common errors in operation or maintenance.

Tip Tips give a special instruction that can save time or provide other benefits while installing or using the product. The tip calls attention to an idea that may not be obvious if you are a first-time user of the product.

1 Hazardous High Voltage

 **HIGH VOLTAGE** Motor control equipment and electronic controllers are connected to hazardous line voltages. When servicing drives and electronic controllers, there may be exposed components with housing or protrusions at or above line potential. Extreme care should be taken to protect against shock.

Stand on an insulating pad and make it a habit to use only one hand when checking components. Always work with another person in case an emergency occurs. Disconnect power before checking controllers or performing maintenance. Be sure equipment is properly grounded. Wear safety glasses whenever working on electronic controllers or rotating machinery.

2 General Precautions - Read These First!

 **WARNING** Failure to read and understand the information provided in this manual may result in personal injury or death, damage to the product, or product failure. Please read each section in its entirety and be sure you understand the information provided in the section and related sections before attempting any of the procedures or operations given.

 **WARNING** This equipment should be installed, adjusted, and serviced by qualified electrical maintenance personnel familiar with the construction and operation of the equipment and the hazards involved. Failure to observe this precaution could result in bodily injury.

 **WARNING** Wiring, maintenance or inspection must be performed by authorized personnel. Not doing so may result in electrical shock or fire.

 **WARNING** Hazard of electrical shock! Disconnect incoming power before working on the Option Board or the Inverter.

 **HIGH VOLTAGE** Turn the power supply OFF and wait for the time specified on the Option Board front cover before performing wiring, maintenance or inspection. Not doing so may result in electrical shock.

The Option Board is attached to an Inverter. Dangerous voltage exists until the Inverter power light is OFF.

 **HIGH VOLTAGE** Do not touch the conductive parts such as the internal PCB, terminals or connector while power is being supplied. Doing so may result in electrical shock.

 **WARNING** Do not attempt to take an Option Board apart or touch any internal parts while the power is being supplied. Doing so may result in electric shock.

 **WARNING** Do not attempt to disassemble, repair, or modify an Option Board. Any attempt to do so may result in malfunction, fire, or electric shock.

 **WARNING** Provide emergency stop circuits, interlock circuits, limit circuits and similar safety measures in external circuits (NOT in the Option Board). This ensures safety in the system if an abnormality occurs due to malfunction of the Option Board or another external factor affecting the Option Board operation. Not doing so may result in serious accidents.

 **WARNING** Fail-safe measures must be taken by the customer to ensure safety in the event of incorrect, missing, or abnormal signals caused by broken signal lines, momentary power interruptions, or other causes. Not doing so may result in serious accidents.

 **Caution** Do not touch the Inverter during power on, and immediately after power off. Hot surface may cause injury.

-  **Caution** The product will be used to control an adjustable speed drive connected to high voltage sources and rotating machinery that is inherently dangerous if not operated safely. Interlock all energy sources, hazardous locations, and guards in order to restrict the exposure of personnel to hazards. The adjustable speed drive may start the motor without warning. Signs on the equipment installation must be posted to this effect. A familiarity with auto-restart settings is a requirement when controlling adjustable speed drives. Failure of external or ancillary components may cause intermittent system operation, i.e., the system may start the motor without warning or may not stop on command. Improperly designed or improperly installed system interlocks and permissives may render a motor unable to start or stop on command.

3 Installation Precautions

-  **WARNING** Always connect the grounding cable to one of the ground terminals of the Inverter. Failure to abide could lead to serious or possibly fatal injury.

-  **Caution** Failure to observe these precautions could lead to faulty operation of the Option Board or the Inverter, or could damage either of the two. Always read these precautions.

- Install external breakers and take other safety measures against short-circuits in external wiring. Not observing this may result in burning.
- Be sure that all cable connector screws are tightened to the torque specified in the relevant manuals. Incorrect tightening torque may result in malfunction.
- Do not allow metal clippings to enter either Option Board or Inverter when wiring or installing the unit.
- Follow the network configuration and wiring instructions provided in the CompoNet Master Unit Operation Manual (Cat. No. W456):
 - Wire the CompoNet cables and connectors correctly. Incorrect wiring may result in burning.
 - Be sure that the network connectors are clicked into place correctly. Improper latching may result in malfunction.
 - Always connect a Terminating Resistor at the prescribed locations of the CompoNet network to ensure the quality of the transmission path. Do not apply termination anywhere else.
- Be sure that the Option Board is mounted correctly. Improper mounting may result in malfunction.
- Disconnect the grounding cable when performing withstand-voltage tests. Not disconnecting the grounding cable may result in burning.

4 Configuration Precautions

-  **Caution** Failure to observe these precautions could lead to unexpected operation of the Option Board or the Inverter. Always read these precautions.

- Check the network related Inverter settings regarding CompoNet node address and CompoNet remote I/O allocation. Not doing so may result in unexpected operation.
- When replacing an Inverter be sure that all Inverter settings of the Inverter being replaced are restored to the replacement.

- When replacing an Option Board be sure that the setting of the rotary switches of the Option Board being replaced are restored to the replacement.
- Restoring parameters stored in the remote operator also restore the CompoNet node address. Always check the node address and other network related Inverter settings after restore.

5 Application Precautions

 **WARNING** Before using the product under conditions which are not described in the manual or applying the product to nuclear control systems, railroad systems, aviation systems, vehicles, combustion systems, medical equipment, amusement machines, safety equipment, and other systems, machines, and equipment that may have a serious influence on lives and property if used improperly, consult your OMRON representative.

 **WARNING** It is extremely important that the Unit is used for its specified purpose and under the specified conditions, especially in applications that can directly or indirectly affect human life. You must consult your OMRON representative before using it in a system in the above-mentioned applications.

 **WARNING** Failure to observe these precautions could lead to serious or possibly fatal injury. Always read these precautions.

- Check any user program in the system that acts as a CompoNet Master before actually running it. Not checking the program may result in unexpected operation.
- For safe operation clear the run command via CompoNet as soon as a trip condition is detected.
- In the event the Inverter is in a Trip state, be sure to investigate the cause of this Trip state thoroughly before clearing the Trip. Not checking the cause may result in unexpected operation.

 **Caution** Failure to observe these precautions could lead to faulty operation of the Option Board or the Inverter, or could damage to either of the two. Always read these precautions.

- Check the Inverter settings for proper Inverter behaviour before actually operating the Inverter remotely via the CompoNet network.
- Check the Inverter's EzSQ program and its interaction with the CompoNet Master before actually running it on the Inverter. Not checking the program may result in unexpected operation.
- Confirm that no adverse effect will occur at the moment the CompoNet Master stops communicating with the Inverter or at the moment the CompoNet Master has not yet started communicating to the Inverter.
- Confirm that no adverse effect will occur in the Inverter before force-setting/force-resetting any bit in the system that acts as a CompoNet Master.

6 Operating Environment Precautions

 **Caution** Do not operate the Inverter with a mounted Option Board in the following locations (doing so may result in malfunction, electric shock or burning):

- Locations subject to direct sunlight
- Locations subject to temperatures or humidity outside the range specified in the specifications
- Locations subject to condensation as the result of severe changes in temperature
- Locations subject to corrosive or flammable gases
- Locations subject to dust (especially iron dust) or salts
- Locations subject to exposure to water, oil, or chemicals
- Locations subject to shock or vibration

 **Caution** Take appropriate and sufficient countermeasures when installing systems in the following locations (doing so may result in malfunction):

- Locations subject to static electricity or other forms of noise
- Locations subject to strong electromagnetic fields
- Locations subject to possible exposure to radioactivity
- Locations close to power supplies

 **Caution** The operating environment of the Inverter with a mounted Option Board can have a large effect on the longevity and reliability of the system. Improper operating environments can lead to malfunction, failure, and other unforeseeable problems with the system. Make sure that the operating environment is within the specified conditions at installation and remains within the specified conditions during the life of the system.

7 Handling, Storage and Disposal

 **Caution** Failure to observe these precautions could lead to faulty operation of or damage to the Option Board. Always read these precautions.

- Before touching the Option Board or Inverter, be sure to first touch a grounded metallic object in order to discharge any static built-up. Not doing so may result in malfunction or damage.
- When transporting or storing the Option Board, keep the product within the specified storage temperature range.

 **Caution** Never dispose electrical components by incineration. Contact your state environmental agency for details on disposal of electrical components and packaging in your area.

8 Compliance with EC Directives

This product complies with EC Directives when mounted to an Inverter with the grounding cable connected.

SECTION 1

Getting Started

1-1 Introduction

1-1-1 Main Features

The 3G3AX-MX2-CRT-E Option Board and the 3G3AX-RX-CRT-E Option Board allow controlling, monitoring and parameterization of an MX2 Inverter or RX Inverter via a CompoNet network. The Option Board serves as a gateway that passes communicated register values from the CompoNet network to the Inverter and vice versa. The Option Board adheres to the CompoNet / CIP AC Drive profile.

The following functions are available via CompoNet communication by installing the Option Board:

Cyclic Data Exchange

The CompoNet Master and Option Board can exchange data via a CompoNet Remote I/O connection:

- Output data (from CompoNet Master to Option Board):
E.g. Run/stop, Reference frequency and Fault reset.
- Input data (from Option Board to CompoNet Master):
E.g. Inverter status, Output frequency and Output current, etc.

Inverter Parameter Access

The CompoNet Master can read and write parameter data via the Option Board using the explicit message communication.

The inverter parameters are accessible in multiple ways:

- Access based on Function code
- Access based on the Modbus register address

Several AC Drive profile attributes can also be accessed using the explicit message mechanism.

Simplified Start-up

The Option Board can be set up easily, just by wiring the Unit, setting the CompoNet node address by either the rotary switches or by setting inverter parameter (P190) and the default connection path (P046) and restarting the Unit. The Unit's configuration is read automatically when the power is turned ON or after a reset. It is not necessary to make any settings with a special Programming Device.

Simplified Replacement

All parameters required by the Option Board are stored in the Inverter. The Option Board can be replaced, requiring no re-configuration.

Automatic Baud Rate Recognition

The Option Board automatically detects the Master's communication baud rate, and no user configuration is required.

1-1-2 Inverter Support

1-1-2-1 Inverter support for the MX2

- MX2** The 3G3AX-MX2-CRT-E Option Board supports the MX2 Inverter with minimum revision of AAAA. An Inverter that supports the 3G3AX-MX2-CRT-E Option Board can be recognized from the Inverter type label. Please check that your Inverter type label displays revision characters in the bottom right corner where the is displayed in this illustration.

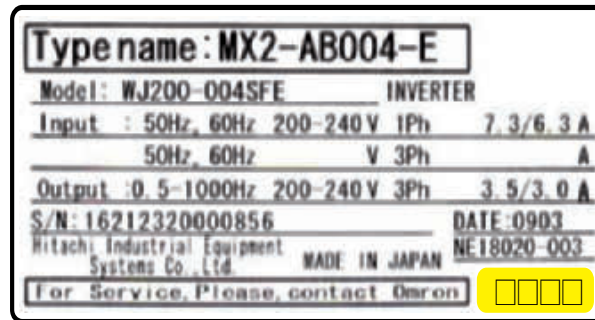

Please note if these characters are absent, your Inverter does not support the 3G3AX-MX2-CRT-E, so please contact your local OMRON representative.

1-1-2-2 Inverter support for the RX

- RX** The 3G3AX-RX-CRT-E Option Board supports the RX Inverter with minimum revision of RX-□-E1F or RX-□-V1. An RX Inverter that supports the 3G3AX-RX-CRT-E Option Board can be recognized from the Inverter type label.

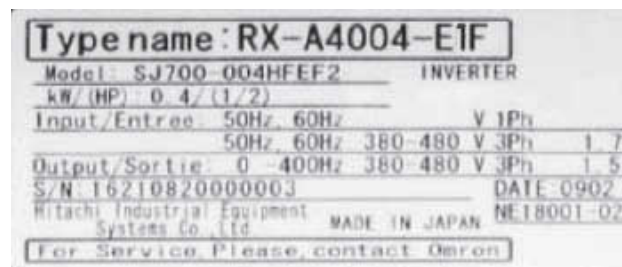

If your RX Inverter has no postfix on type label (e.g. RX-A4004) or the EF postfix (e.g. RX-A4004-EF) the 3G3AX-RX-CRT-E option is not supported, so please contact your local OMRON representative.

1-1-3 Inverter Safety (ISO 13849-1)

- MX2** An MX2 Inverter provides a Gate Suppress function to perform a safe stop according to the EN60204-1, stop category 0. The Option Board has been designed not to interfere with this safety function.

Note The 3G3AX-MX2-CRT-E Option Board is not a safety device and does not implement any safety protocols.

1-2 Option Board Specifications

Table 1 Option Board Specification

	Item	Specification	
MX2	Installation MX2	Unit type	MX2 Series Option Board
		Model	3G3AX-MX2-CRT-E
		Dimensions (W x H x D)	68 x 58 x 45 mm
		Weight	170g (typical)
RX	Installation RX	Unit type	RX Series Option Board
		Model	3G3AX-RX-CRT-E
		Dimensions (W x H x D)	80 x 67 x 49 mm
		Weight	170 g (typical)
Environment	Ambient operating temperature	-10 to 55°C (no icing or condensation)	
	Ambient operating humidity	20 to 90%RH	
	Ambient storage temperature	-20 to 65°C (no icing or condensation)	
	Vibration resistance	5.9m/s ² (0.6G) at 10...55Hz	
	Dielectric strength	500 VAC (between isolated circuits)	
	Conformance to EMC and Electrical safety standards	EN61800-3: 2004 (2004/108/EC) Second environment, Category C3 EN61800-5-1: 2007 (2006/95/EC) SELV	
	Enclosure rating	IP 20	
CompoNet Interface	Communications protocol	CompoNet	
	Slave Type	Word Slave Unit (Mixed)	
	Certification	CompoNet Conformance Tested	
	CompoNet Profile	AC Drive (0x02)	
	Node address	0 to 63, set with inverter parameter P190 or the rotary switches	
	Baud rates supported	4 Mbps, 3 Mbps, 1.5 Mbps, 93.75 kbps. Automatically detecting baud rate of Master Unit	
CompoNet Configuration	Default Connection path	Supported, set with inverter parameter P046	
	Supported Assemblies	Basic Remote IO (Output assembly 20, Input assembly 70) Extended Speed IO (21, 71) Extended Speed and Torque Control (123, 173) Special IO (100, 150) Extended Control IO (101, 151) Extended Control IO and Multi function IO monitor (101, 153) Flexible Format (139, 159) Extended Speed and Acceleration Control (110, 111) In case the CompoNet master is configured using user allocation, only the input / output pairs can be configured.	
	EDS file	Depending on the Inverter model (see below)	

Note 1 The derated- or ambient operating temperature of the Inverter takes precedence over that of the Option Board.

Note 2 In case the Option Board is connected to the Inverter, it is not supported to connect any external devices to the RS485 (Modbus) interface.

MX2 In case the 3G3AX-MX2-CRT-E Option Board is connected to the MX2 Inverter, it is not supported to connect any external devices the RJ45 port (Optional operator port) of the Inverter.

The required EDS file for the Option Board depends on the model of the MX2 or RX inverter.

Table 2 MX2 Device List

MX2	MX2 Model name	Name of EDS file	Product Code
	MX2-AB001-E	3G3AX-MX2-CRT-AB001_A2001-E.eds	1800
	MX2-A2001-E		
	MX2-AB002-E	3G3AX-MX2-CRT-AB002_A2002-E.eds	1801
	MX2-A2002-E		
	MX2-AB004-E	3G3AX-MX2-CRT-AB004_A2004-E.eds	1802
	MX2-A2004-E		
	MX2-AB007-E	3G3AX-MX2-CRT-AB007_A2007-E.eds	1804
	MX2-A2007-E		
	MX2-AB015-E	3G3AX-MX2-CRT-AB015_A2015-E.eds	1806
	MX2-A2015-E		
	MX2-AB022-E	3G3AX-MX2-CRT-AB022_A2022-E.eds	1807
	MX2-A2022-E		
	MX2-A2037-E	3G3AX-MX2-CRT-A2037-E.eds	1809
	MX2-A2055-E	3G3AX-MX2-CRT-A2055-E.eds	1811
	MX2-A2075-E	3G3AX-MX2-CRT-A2075-E.eds	1812
	MX2-A2110-E	3G3AX-MX2-CRT-A2110-E.eds	1813
	MX2-A2150-E	3G3AX-MX2-CRT-A2150-E.eds	1814
	MX2-A4004-E	3G3AX-MX2-CRT-A4004-E.eds	1822
	MX2-A4007-E	3G3AX-MX2-CRT-A4007-E.eds	1824
	MX2-A4015-E	3G3AX-MX2-CRT-A4015-E.eds	1826
	MX2-A4022-E	3G3AX-MX2-CRT-A4022-E.eds	1827
	MX2-A4030-E	3G3AX-MX2-CRT-A4030-E.eds	1828
	MX2-A4040-E	3G3AX-MX2-CRT-A4040-E.eds	1830
	MX2-A4055-E	3G3AX-MX2-CRT-A4055-E.eds	1831
	MX2-A4075-E	3G3AX-MX2-CRT-A4075-E.eds	1832
	MX2-A4110-E	3G3AX-MX2-CRT-A4110-E.eds	1833
	MX2-A4150-E	3G3AX-MX2-CRT-A4150-E.eds	1834

Table 3 RX Device List

RX	RX Model name	Name of EDS file	Product Code
	RX-A2004-E	3G3AX-RX-CRT-A2004-E.eds	2041
	RX-A2007-E	3G3AX-RX-CRT-A2007-E.eds	2042
	RX-A2015-E	3G3AX-RX-CRT-A2015-E.eds	2043
	RX-A2022-E	3G3AX-RX-CRT-A2022-E.eds	2044
	RX-A2037-E	3G3AX-RX-CRT-A2037-E.eds	2045
	RX-A2055-E	3G3AX-RX-CRT-A2055-E.eds	2046
	RX-A2075-E	3G3AX-RX-CRT-A2075-E.eds	2047
	RX-A2110-E	3G3AX-RX-CRT-A2110-E.eds	2048
	RX-A2150-E	3G3AX-RX-CRT-A2150-E.eds	2049
	RX-A2185-E	3G3AX-RX-CRT-A2185-E.eds	2050
	RX-A2220-E	3G3AX-RX-CRT-A2220-E.eds	2051
	RX-A2300-E	3G3AX-RX-CRT-A2300-E.eds	2052
	RX-A2370-E	3G3AX-RX-CRT-A2370-E.eds	2053
	RX-A2450-E	3G3AX-RX-CRT-A2450-E.eds	2054
	RX-A2550-E	3G3AX-RX-CRT-A2550-E.eds	2055
	RX-A4004-E	3G3AX-RX-CRT-A4004-E.eds	2068
	RX-A4007-E	3G3AX-RX-CRT-A4007-E.eds	2069

Table 3 RX Device List (continued)

RX	RX Model name	Name of EDS file	Product Code
	RX-A4015-E	3G3AX-RX-CRT-A4015-E.eds	2070
	RX-A4022-E	3G3AX-RX-CRT-A4022-E.eds	2071
	RX-A4040-E	3G3AX-RX-CRT-A4040-E.eds	2072
	RX-A4055-E	3G3AX-RX-CRT-A4055-E.eds	2073
	RX-A4075-E	3G3AX-RX-CRT-A4075-E.eds	2074
	RX-A4110-E	3G3AX-RX-CRT-A4110-E.eds	2075
	RX-A4150-E	3G3AX-RX-CRT-A4150-E.eds	2076
	RX-A4185-E	3G3AX-RX-CRT-A4185-E.eds	2077
	RX-A4220-E	3G3AX-RX-CRT-A4220-E.eds	2078
	RX-A4300-E	3G3AX-RX-CRT-A4300-E.eds	2079
	RX-A4370-E	3G3AX-RX-CRT-A4370-E.eds	2080
	RX-A4450-E	3G3AX-RX-CRT-A4450-E.eds	2081
	RX-A4550-E	3G3AX-RX-CRT-A4550-E.eds	2082
	RX-B4750-E	3G3AX-RX-CRT-B4750-E.eds	2083
	RX-B4900-E	3G3AX-RX-CRT-B4900-E.eds	2084
	RX-B411K-E	3G3AX-RX-CRT-B411K-E.eds	2085
	RX-B413K-E	3G3AX-RX-CRT-B413K-E.eds	2086

1-3 Introduction to CompoNet

1-3-1 Overview of CompoNet

CompoNet Networks feature easy operation and installation in a component level network connecting PLCs and on-site I/O. The PLC and CompoNet Slave Units cyclically exchange I/O information through a CompoNet Master-Unit, refreshing I/O in sync with the PLC scan. CompoNet (just like DeviceNet) is a member of a family of networks that implements the Common Industrial Protocol (CIP) at its upper layers. Two types of communications are supported to provide a single point of connection for both control and configuration:

1. Time-critical control remote I/O communications that automatically transfer between the Master Unit/CPU Unit and the remote Slave Units, and
2. Explicit message communications that read/write messages, control operation, or perform other functions to the Slave Units. Message communications are achieved by executing specific instructions from the program in the CPU Unit to which the Master Unit is mounted.

1-3-2 CompoNet Slave Unit Groups

CompoNet Slave Units can be classified into the following groups:

Word Slave Units

Word Slave Units are Slave Units that are allocated units of 16 bits (i.e., 1 word) in I/O memory of the CPU Unit.

Bit Slave Units

Bit Slave Units are Slave Units that are allocated units of 2 bits in I/O memory of the CPU Unit. Bit Slave Units provide 2 or 4 digital contact I/O points and have Standard or Sheathed Flat Cable already connected.

Repeater Units

Units that can be used to expand the network by extending trunk lines or branching

1-3-3 What is the AC Drive profile

Within CompoNet/CIP standard, multiple device profiles have been defined. Therefore the devices which adhere to a certain device profile are compatible and replaceable in a multi-vendor environment.

The AC Drive device profile (profile code 0x02) supplements the CompoNet/CIP standard. It defines a unified behaviour and technique to access Inverter and drive device data. All drives supporting the AC Drive profile respond the same way to control instructions.

SECTION 2 Option Board Mounting and Installation

2-1 Orientation to Option Board Features

2-1-1 Unpacking and Inspection

Take a few moments to unpack your new Option Board and perform these steps:

1. Look for any damage that may have occurred during transportation.
2. Verify the contents of the box.
3. Inspect the markings on the Option Board. Make sure it matches the product part number you ordered.

MX2

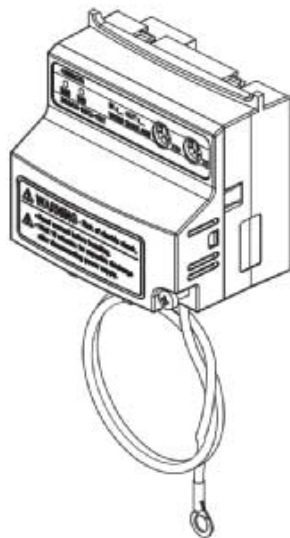

Option Board with Grounding Cable and CompoNet connector



Instruction Sheet



Warning Labels

RX

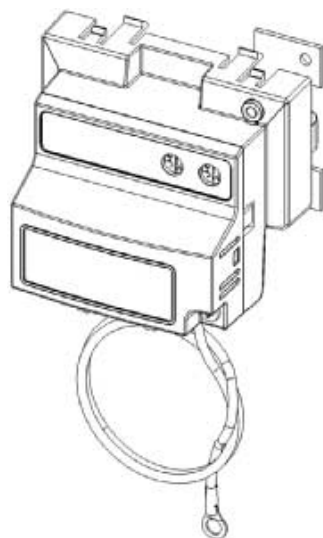

Option Board with Grounding Cable and Blind cover



Instruction Sheet

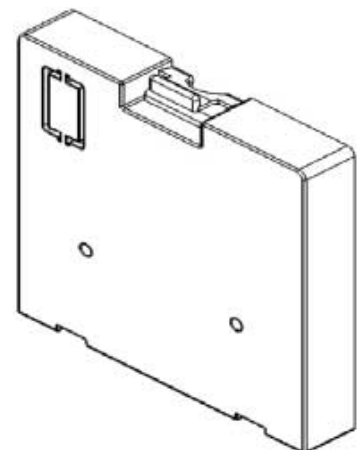

Blind cover

2-1-2 Main Physical Features

MX2

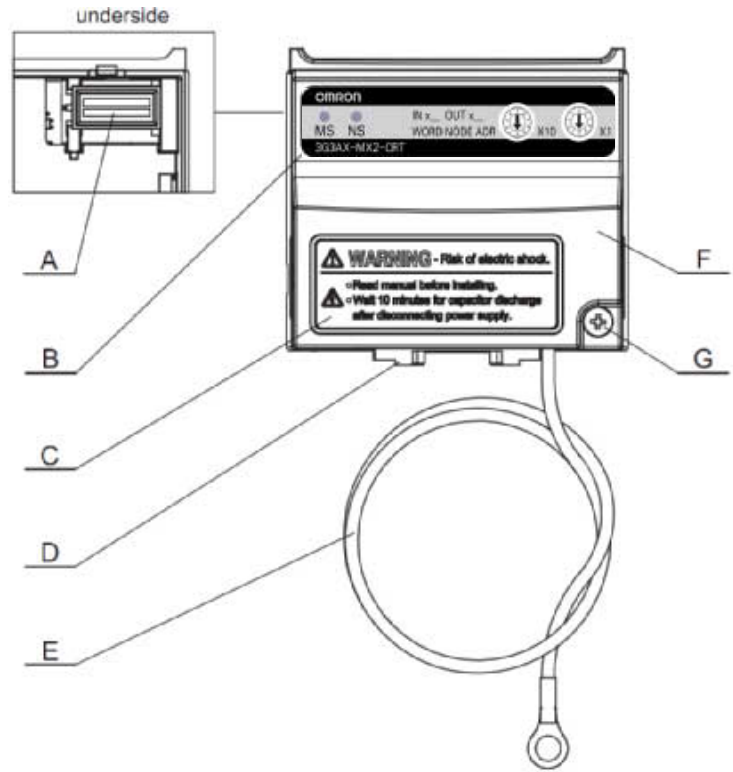

- A - Option Board connector
- B - LED indicators (MS, NS)
- C - Warning label
- D - Fieldbus connector
- E - Grounding cable
- F - Housing
- G - Mounting screw

RX

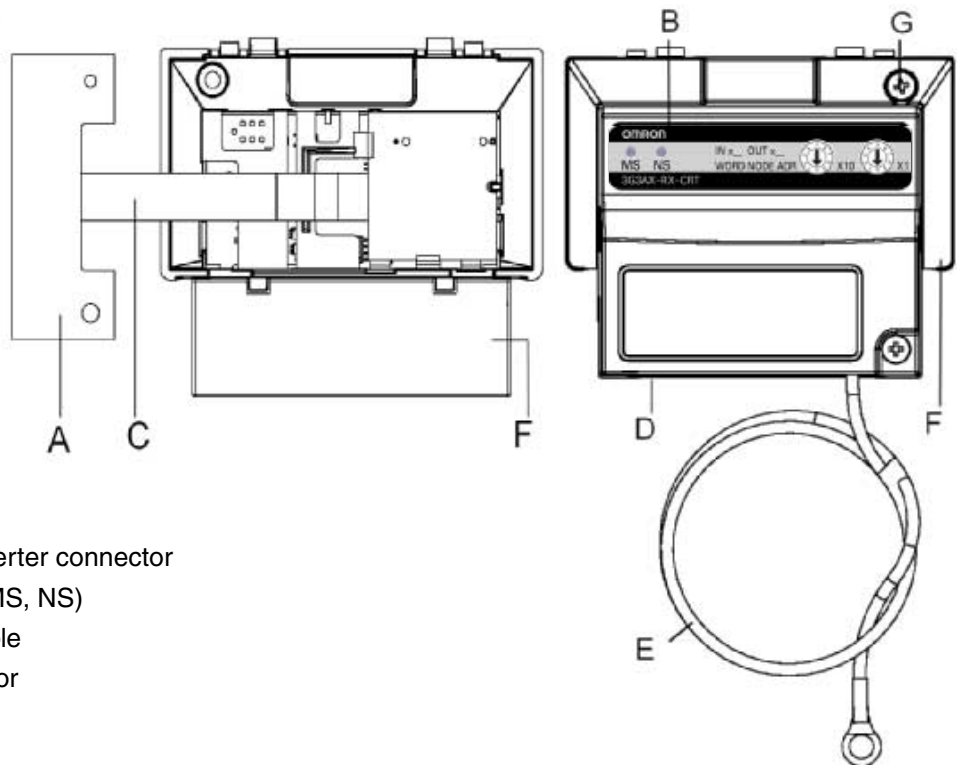

- A - Option Board Inverter connector
- B - LED indicators (MS, NS)
- C - Option Board cable
- D - Fieldbus connector
- E - Grounding cable
- F - Housing
- G - Mounting screw

The LED indicators (B) allow easy diagnosis. An attached grounding cable (E) is sized to reach the ground terminals on all Inverter models. A feature in the housing (F) will retain the mounting screw (G) when the Option Board is not mounted to the Inverter. The orientation of the Fieldbus connector (D) allows unstrained connection and removal of the CompoNet connector.

Please pay attention to the Option Board Inverter connector: It must be properly connected with the Inverter Interface Connector.

2-1-3 LED Indicators

The LED indicators on the front indicate the operational mode and status of the Option Board and the network.

Table 4 LED Indicators

Indicator	Colour	Status	Meaning
MS (Module status)		Not lit	<ul style="list-style-type: none"> Power is not supplied to the Option Board Option Board is being reset
	Green	Lit	Normal operation
	Red	Lit	Unrecoverable fault: <ul style="list-style-type: none"> Option Board hardware error Unsupported Inverter version
		Flashing	Recoverable fault: <ul style="list-style-type: none"> Network power is OFF Node address changed Illegal Flexible configuration Option Board parameters out of range or cannot be read Option Board detects consecutive communication errors
NS (Network status)		Not lit	<ul style="list-style-type: none"> Power not supplied (check Module Status LED) Checking for node address duplication (intermediate state)
	Green	Lit	Network is operating normally (communications established)
		Flashing	Network is operating normally, but communications have not been established.
	Red	Lit	Option Board detects network communication not possible due to Communications error: <ul style="list-style-type: none"> Node address duplication Network error
		Flashing	Option Board detects communication lost. One or more Connections are in time-out state.

Note Refer to section 5-1 for Troubleshooting using the LED indicators on page 39.

2-1-4 Rotary Switches

The rotary switches are used to set the node address of the Option Board on the CompoNet network. Set the node address as a decimal number between 0 and 63.

Set the 10s digit on the left rotary switch and set the 1s digit on the right rotary switch. The setting of the switches is read when the Unit power supply turns ON.



There are two ways of configuring the CompoNet node number.

1. Set the node address by the rotary switches to a valid value in the range 0 to 63.
2. Set the node address by Inverter parameter P190. Set the rotary switches to an invalid value (between 64 to 99) to set the node address as the value of the P190 parameter.

See Section 3-2 *Configuring the Option Board* on page 23 for more details.



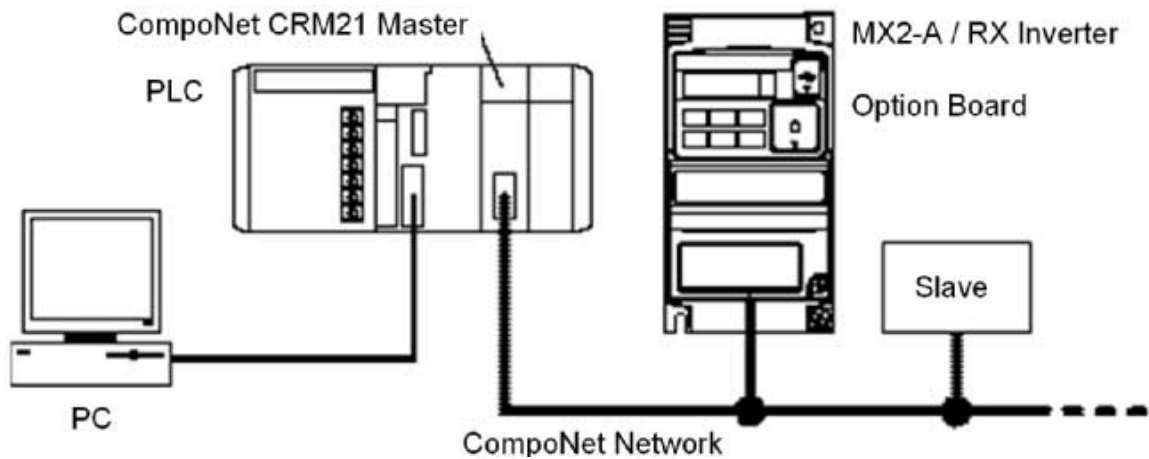





2-2 Basic System Description



The Option Board connects to the Master via a CompoNet network cable. Inverter I/O data is generally shared with the Master's I/O memory through the CompoNet network.

Every CompoNet communication cycle, Inverter I/O data is collected by the Option Board and exchanged with the Master. The PC (personal computer) allows you to configure, monitor, program, diagnose and operate the system.

2-3 How to mount the Option Board on the Inverter

-  **HIGH VOLTAGE** Always switch OFF the mains power supply to the Inverter before removing any covers. Wait for the time specified on the Inverter front cover for the capacitors to discharge. Not doing so may result in electrical shock.
-  **HIGH VOLTAGE** Never operate the Inverter with the terminal block cover or backing plate removed.
-  **WARNING** Always connect the grounding cable to one of the ground terminals of the Inverter. Failure to abide could lead to serious or possibly fatal injury.
-  **WARNING** Provide emergency stop circuits, interlock circuits, limit circuits and similar safety measures in external circuits (NOT in the Option Board). This ensures safety in the system if an abnormality occurs due to malfunction of the Option Board or another external factor affecting the Option Board operation. Not doing so may result in serious accidents.
-  **Caution** Never touch the heat sink during or just after operation; it can be very hot.
-  **Caution** Be sure that the Option Board is mounted correctly. Improper mounting may result in malfunction.
-  **Caution** Be sure that all cable connector screws are tightened to the torque specified in the relevant manuals. Incorrect tightening torque may result in malfunction.
- Note** Illustrations are only provided for one Inverter size. The instructions however are generic, and may be followed for all Inverter sizes.
-  **MX2** Please refer to the MX2 Inverter manual (Cat. No. I570) section 2-1-3 for details on assembly and disassembly of the Inverter.
-  **RX** Please refer to the RX Inverter manual (Cat. No. I560) section 2 for details on assembly and disassembly of the Inverter.

2-3-1 Mounting sequence of the Option Board on the MX2 Inverter

Step 1

MX2 Loosen the screw of the Option Board cover.
Remove the cover and put the cover aside.

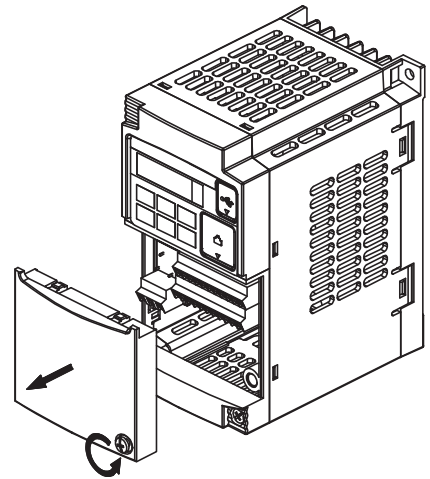

Step 2

MX2 For Inverters up to 4.0 kW only: loosen the screws of the terminal block cover
Remove the cover to enable access to the chassis ground terminal screws.

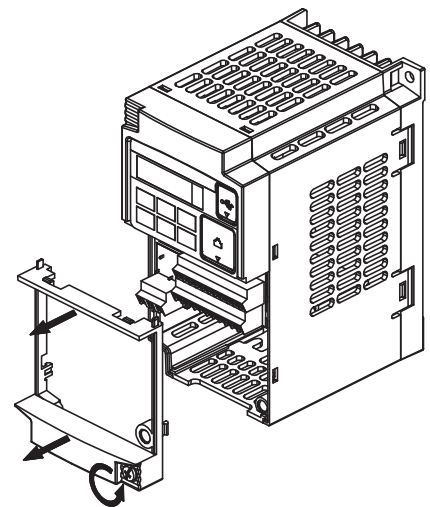

Step 3

MX2 Secure the Option Board grounding cable to the MX2-A□ Inverter with a mounting screw.

1-phase 200 V 0.1 - 2.2 kW
3-phase 200 V 0.1 - 3.7 kW
3-phase 400 V 0.4 - 4.0 kW

3-phase 200 V 5.5 - 15 kW
3-phase 400 V 5.5 - 15 kW

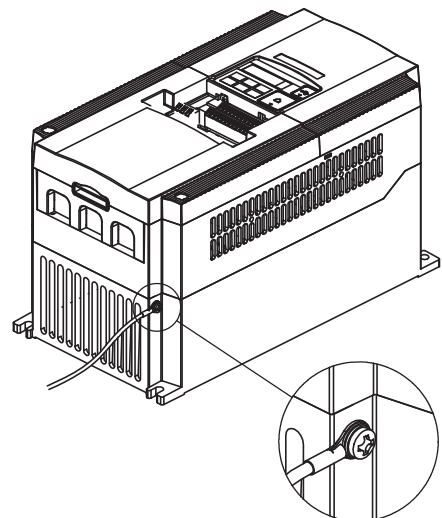
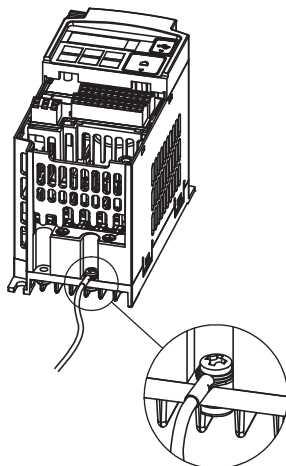

Step 4

MX2 If removed in Step 2, mount the terminal cover again and tighten the screw(s).

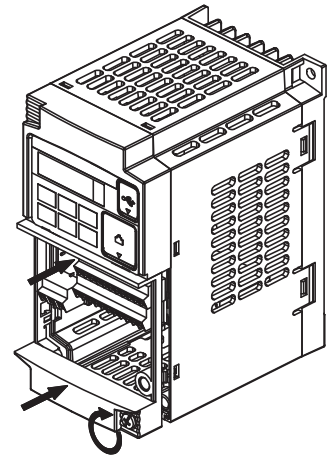

Step 5

MX2 Push the Option Board into the previous location of the Option Board cover until it clicks into place

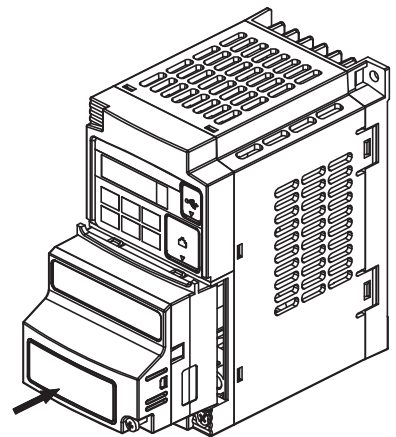

Step 6

MX2 Press down on the indicated corner of the Option Board housing to ensure proper connection of the Option Board connector

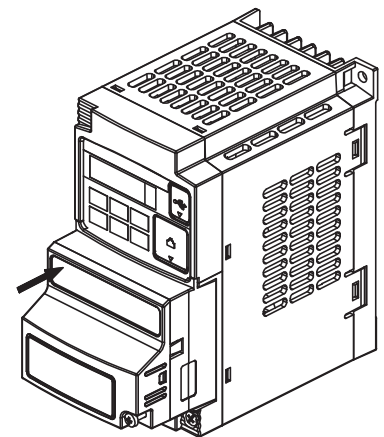

Step 7

MX2 Check that there is no gap between the top edges of the Option Board and the Inverter casing.

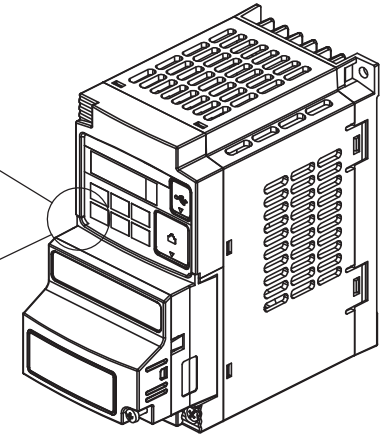
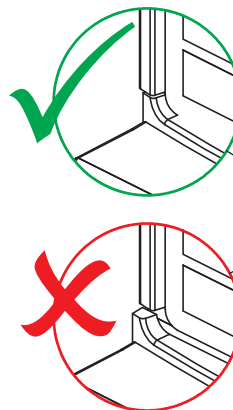

Step 8

MX2 Secure the Option Board in place with the mounting screw (do not over-tighten).

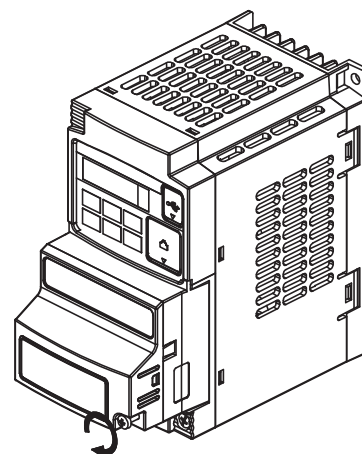

Step 9

MX2 Select the right warning language from the warning label sheet and replace the English warning if appropriate.

MX2 Refer to section 2-1-3 in the MX2 User's Manual (Cat. No. I570) for operations related to assembly and disassembly of the MX2-A□ Inverter.

Note Some Inverter models do not include a screw for the grounding cable. Please supply the recommended screw, lock-washer and washer to attach the grounding cable.

Table 5 Ground cable screw selection MX2

Inverter models	Grounding Cable Attachment Screw
3-phase 200 V 5.5 – 7.5 kW	M4 x 6
3-phase 400 V 5.5 – 7.5 kW	
3-phase 200 V 11 – 15 kW	M5 x 6
3-phase 400 V 11 – 15 kW	

2-3-2 How to install the Option Board on the RX Inverter

2-3-2-1 Preparation

- RX** When the Option Board is mounted on the RX Inverter, the Digital Operator Display can not be directly connected back on the RX Inverter. There are two solutions:

Commissioning with Digital Operator Display

This option is recommended, however it does require a straight Ethernet cable.

- Step 1** **RX** Mount the Option Board according paragraph 2-3-2-2 *Mounting sequence of the Option Board on the RX Inverter on page 15*.
- Step 2** **RX** Connect the Digital Operator Display using the 3G3AX CAJOP300-EE cable or straight Ethernet cable.
- Step 3** **RX** Set the desired parameters of the RX Inverter with the Digital Operator Display.

Commissioning via CompoNet

- Step 1** **RX** Configure CompoNet communication parameters before mounting the Option Board. See also paragraph 3-2 *Configuring the Option Board on page 23*:
- *Step 2* on page 27: Set the CompoNet node number.
 - *Step 3* on page 23: Set the Inverter parameter P046 Default Connection Path.
- Step 2** **RX** Mount the Option Board according paragraph 2-3-2-2 *Mounting sequence of the Option Board on the RX Inverter on page 15*. Set the desired parameters of the Inverter (Also referenced in this paragraph)
- Step 3** **RX** Configure the Inverter without Digital Operator:
- Use the OMRON CX-Drive tool, or
 - Use CX-Integrator with the unit's EDS file (see paragraph 4-1 *Setting up inverter on page 29*), or
 - Use Explicit messages to access the parameters directly (refer to Appendix E-1 *Basic Format of Explicit Messages on page 83*).

2-3-2-2 Mounting sequence of the Option Board on the RX Inverter

- Step 1** **RX** Remove from the RX- Inverter:

1. Digital Operator Display
2. Terminal cover
3. Front Cover
4. Operator connector.

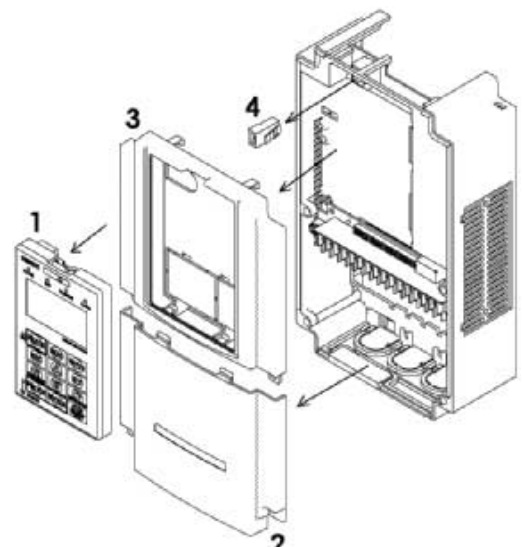

Step 2

- RX** Cut out the 2 plastic break-outs from the Front Cover.
Make sure no sharp edges remain.

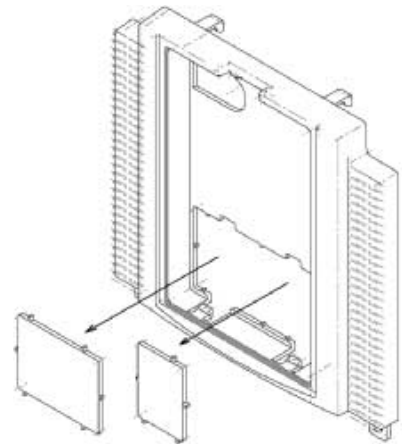

Step 3

- RX** Remount the Front Cover and tighten the screws

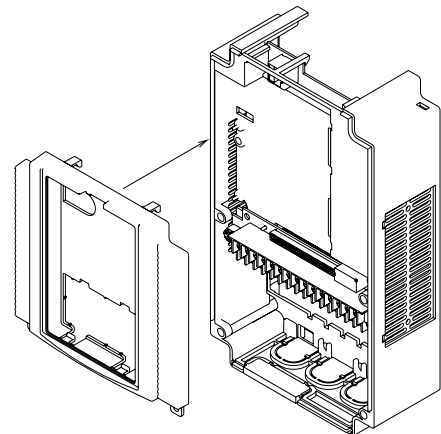

Step 4

- RX** Purpose: mount the Inverter Connector (no.1) of the Option Board onto the interface connector (no.5) of the RX Inverter.

How to do:

First align the small hole of the Inverter connector (no.2) with the guide-post (no.4) in the Inverter.

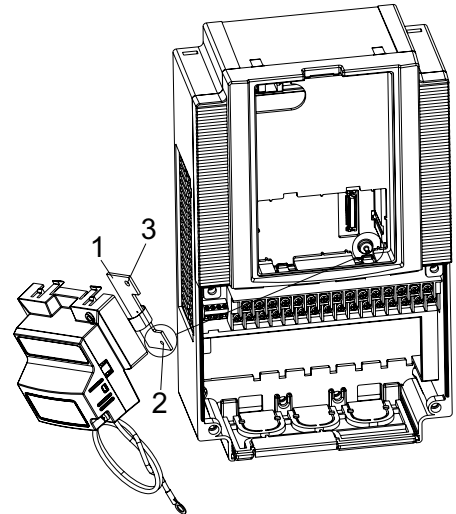

Then align the larger hole on the Inverter connector (no.3) with the threaded hole (no.6) in the Inverter.

Push the Inverter connector into place.

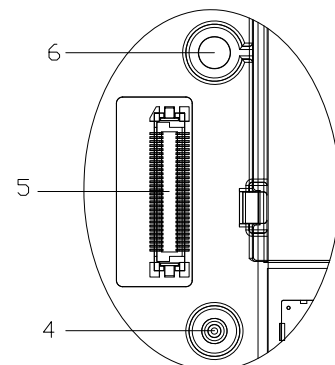

Step 5

RX Move the Option Board Cable (no.2) to the left with your finger, so the Option Board Cable is not pinched between the Option Board and the Inverter Front Cover.

Note Prevent a pinched Option Board Cable, as shown in position A.

Note Do not pull on the Option Board Cable.

Note Do not let the Option Board hang on the Option Board Cable.

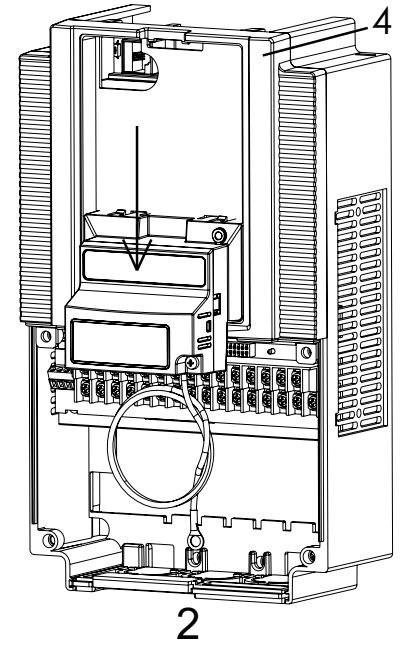
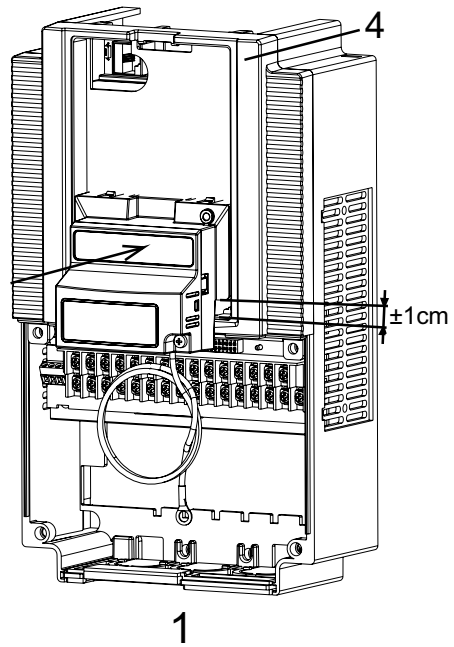
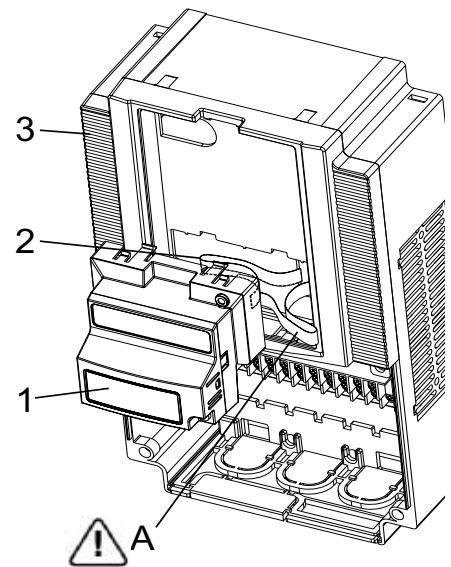

Insert the Option Board approximately 1 cm above the down-position into the Front cover of the Inverter. See figure 1 above.

Slide the Option Board down. See figure 2 above.

The snap-fits of the Option Board (no.5) will be locked by the snap-fits in the Front cover (no.4).

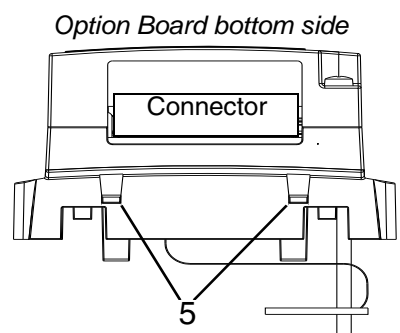

Step 6

RX Press down carefully the two locking pins (no. 1) of the Option Board.

Press carefully the top of the Option Board in the Inverter.

Check the Option Board is being locked by the locking pins (no.1).

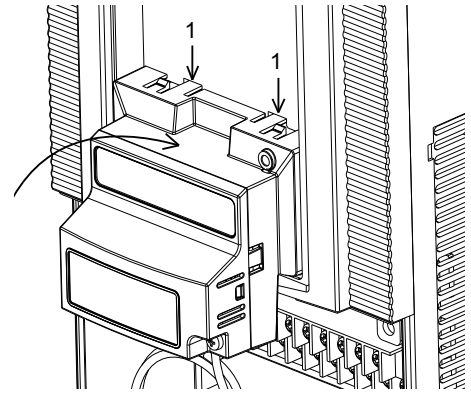

Step 7

RX Insert the screw (no. 1) into the upper right hole in the Option Board (no.2).

Tighten the screw into place (do not over tighten).

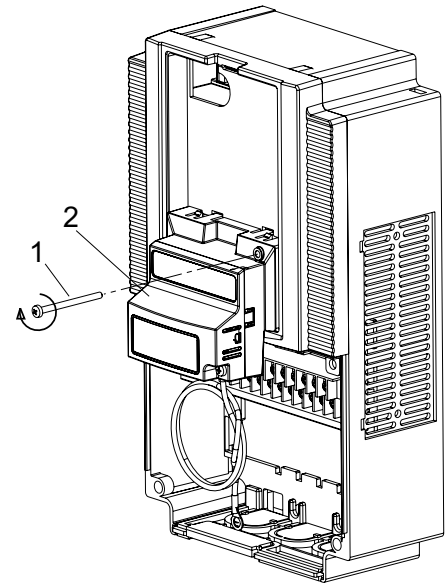

RX Fix the Option Board grounding cable to the chassis ground of the RX-Inverter under an already fixed chassis grounding bolt.

See the bold with the grounding figure.

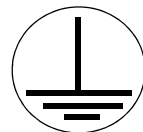

The position of the chassis ground vary from inverter type. Illustrations are only provided for one Inverter size. The instructions however are generic and may be followed for all Inverter sizes.

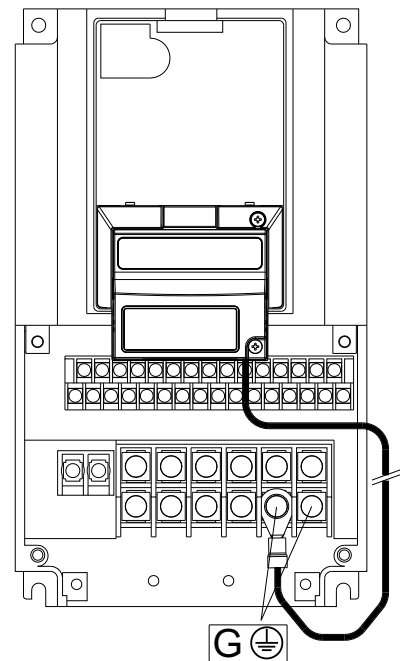

Step 8

RX Unscrew the mounting screws of the Terminal cover nearly completely from the plastic rings (no.1).

Remount the Terminal cover under the Option Board onto the Inverter (no.2).

Tighten the two screws (no.1).

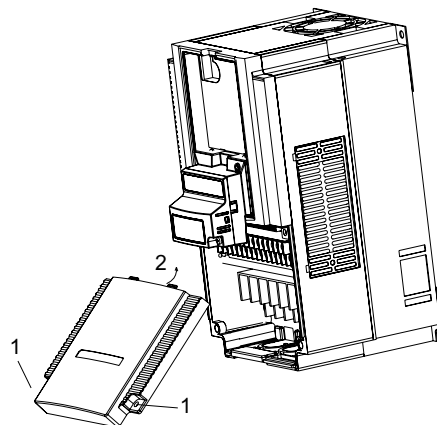

Step 9

RX Connect the Digital Operator Display via a 3G3AX CAJOP300-EE cable or via a straight EtherNet cable with the RJ45 connector in the Inverter.

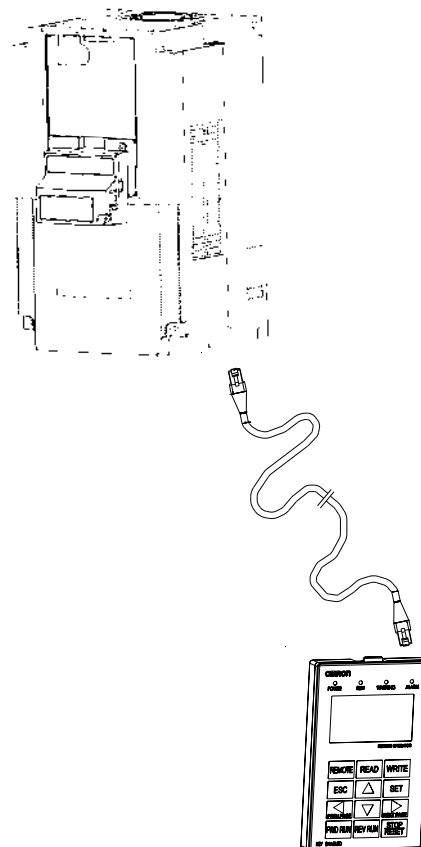

Step 10

RX Define needed and desired parameters of the Inverter and set them according *SECTION 3 Configuring Drive Parameters and Option Board on page 23* and also according *SECTION 4 Operations and Monitoring on page 29*.

Step 11

RX If the desired parameters of the Inverter have been set successfully, disconnect the 3G3AX CAJOP300-EE cable or straight EtherNet cable from the Inverter.

Push the blind cover (no.1) into place.

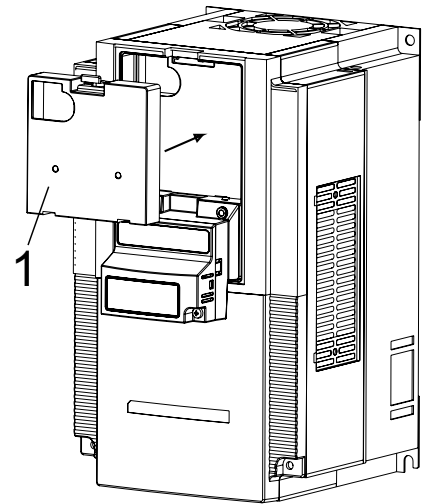

Note Refer to section 2 in the RX User's Manual (Cat. No. I560) for operations related to assembly and disassembly of the RX Inverter.

2-3-3 Installation Environment Clearance

In addition to this, provide sufficient clearance to allow connection and removal of the CompoNet connector.

MX2 Please adhere to the requirements of section 2-1 in the MX2 User's manual (Cat. No. I570) on "Installation Environment".

RX Please adhere to the requirements of section 2-1 in the RX User's manual (Cat. No. I560) on "Installation Environment".

No unnecessary strain should be placed on the CompoNet cable or connector that could be transferred to the Option Board.

2-3-4 CompoNet network connector

You can use different types of communications cable in as CompoNet network. You can use the connector to connect either a flat cable or round cable. Refer to the CS/CJ-Series CompoNet Master Unit Operation Manual (Cat. No. W456) for the connection procedure.

Table 6 CompoNet connector signals

	Colour	Signal	Description
	Red	BS+	Communications power supply (24VDC)
	White	BDH	Communications data lines (high)
	Blue	BDL	Communications data lines (low)
	Black	BS-	Communications power supply (0VDC)

Note The BS+ (communications power supply +) and BS- (communications power supply -) are not connected internally in the Option Board. Connecting them on the connector is not strictly required.

2-3-5 Option Board Dimensions

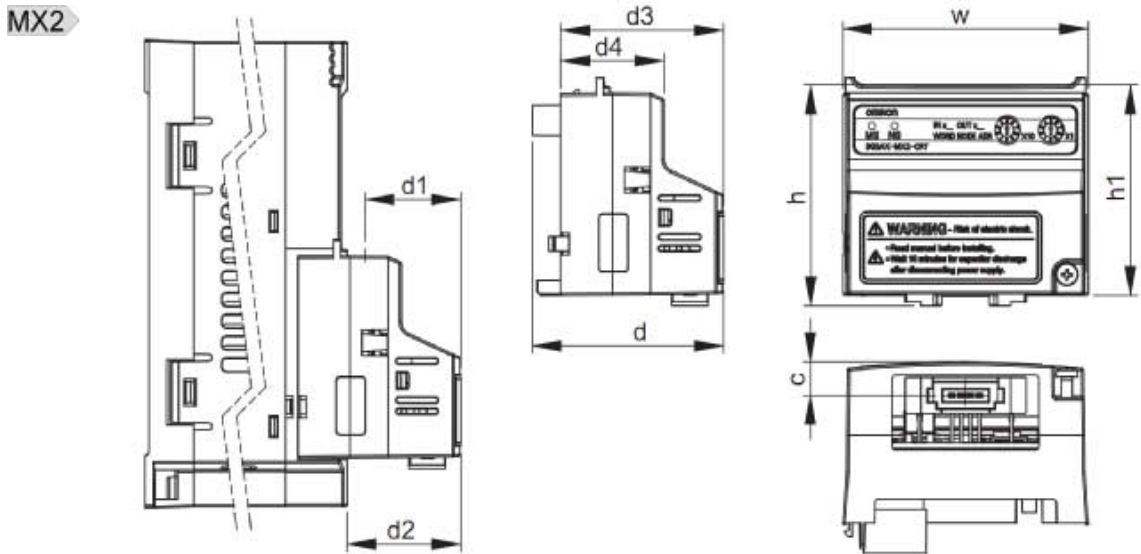

Table 7 Option Board Dimensions on the MX2 Inverter

Item	Dimension	Item	Dimension	Item	Dimension
h	60.7 mm	c	18.7 mm	d2	31.3 mm
h1	57.9 mm	d	52.6 mm	d3	44.8 mm
w	67.6 mm	d1 ¹	26.4 mm	d4	28.4 mm

1. Dimension d1 gives the increase in MX2 Inverter dimension D when the Option Board is fitted. Please refer to section 2-3 of the MX2 User's manual (Cat. No. I570).

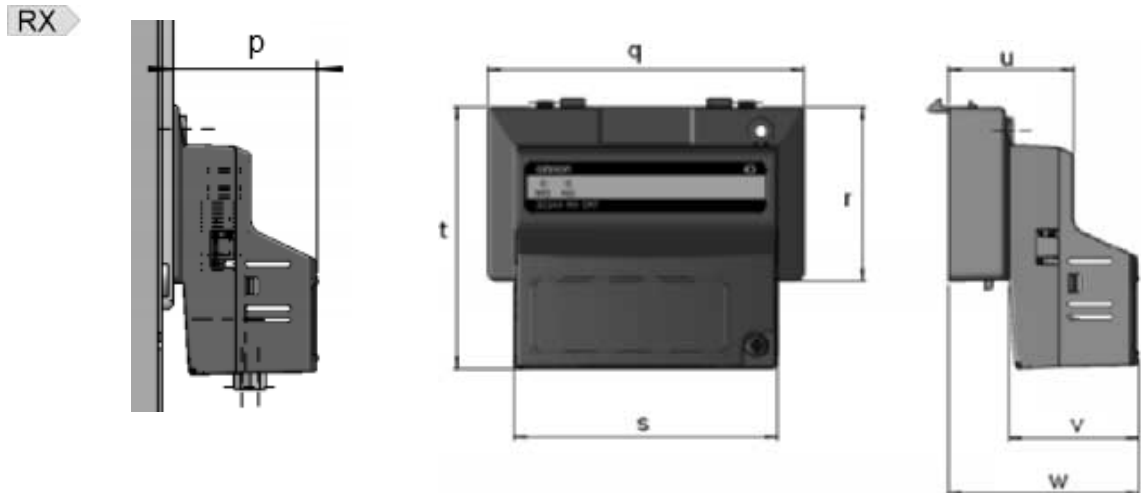

Table 8 Option Board Dimensions on the RX Inverter

Item	Dimension	Item	Dimension	Item	Dimension
p	35.1 mm	r	43.9 mm	u	31.7 mm
q	79.8 mm	s	66.5 mm	v	32.7 mm
		t	66.1 mm	w	48.1 mm

SECTION 3

Configuring Drive Parameters and Option Board

3-1 Installation of EDS files

For each of the Inverter models and capacities, a specific EDS file exists for the Option Board. The EDS files contain specific parameter data (default, ranges) depending on the model. Perform the following steps to install the EDS files prior to configure the network.

- Step 1** Download the EDS files named *3G3AX-MX2-CRT-□-E.eds* and/or *3G3AX-RX-CRT-□-E.eds* for the Option Board via the Omron website (<http://industrial.omron.eu>).
- Step 2** Install / add these EDS files to the CompoNet Master Unit configuration program used to configure your CompoNet master.

3-2 Configuring the Option Board

All Option Board parameters are stored in the Inverter.

This allows for easy replacement of the Option Board without the need to re-configure. After connecting the Option Board to an Inverter for the first time however, proceed with the following steps:

- Step 3** There are two ways of configuring the CompoNet node number.
1. Set the CompoNet node number using the rotary switches on the front of the Unit.
 2. Set the rotary switches to an invalid value (64 to 99) and configure Inverter parameter P190. Use either the Inverter keypad or any other method of configuring the inverter parameters. See note 1.

Table 9 Configuration of Node Number

Param	Description	Setting
P190	CompoNet Node Address	0 to 63 (default: 0)

- Step 3** If you use the automatic / fixed allocation mechanism of the CompoNet Master Unit, choose the required Output and Input assembly pair using inverter parameter P046 Default Connection Path.

Table 10 Default Connection Path

P046 value	Description	Assembly nr (Hex)	
		Output	Input
0	Basic Speed IO	20	70
1	Extended Speed IO (default)	21	71
2	Extended Speed and Torque Control	123	173
3	Special IO	100	150
4	Extended Control IO	101	151
5	Extended Control IO and Multi Function IO Monitor	101	153
6	Flexible Format	139	159
7	Extended Speed and Acceleration Control	110	111

- Step 4** It is recommended to set C102 = 3 to prevent the Inverter reset input (RS) and Stop/reset button from interfering with Option Board during operation. Setting C102 to another value causes the Option Board to reset when a trip condition is cleared. See the Inverter User's manual (MX2: Cat. No. I570, RX: Cat. No. I560) for details on this parameter.

Table 11 Configuration of Inverter Reset Mode Selection

Param	Description	Setting
C102	Reset mode selection	Set to 3 "Resetting only trip" (recommended setting)

Step 5

Inverter registers P044, P045 and P048 configure the CompoNet network-related parameters. Adjust these to configure required action in case a fieldbus network IDLE mode behaviour and/or a fieldbus failure occurs.

Table 12 Configuration of CompoNet Parameters

Param	Description	Setting
P044	Network Error Timer	Communication watchdog timer while running. Note additional to CompoNet inactivity / watchdog timer. 0 to 9999 in 0.1 s unit. Set to 0 to disable.
P045	Action on Network Error	Set to 0 for inverter trip (Default) Set to 1 for deceleration and trip Set to 2 for no action Set to 3 for stop due to free-run Set to 4 for deceleration and stop
P048	Action on Network Idle Mode	Set to 0 for inverter trip (Default) Set to 1 for deceleration and trip Set to 2 for no action Set to 3 for stop due to free-run Set to 4 for deceleration and stop

Step 6

Registers A001 and A002 are used by the Inverter to adjust the frequency source and control source. If the second motor parameter set is used, registers A201 and A202 also have to be set.

MX2 Apply the source selection parameters according the following table for the MX2 Option Board:

Table 13 Configuration of Source Selection MX2 Parameters

Param	Description	Setting
A001	Motor 1 Frequency Source	For Option Board as source: Set to 4 "Option Board Interface" for all assemblies except Flexible format (P046 is not 6)
A002	Motor 1 Run Command Source	Set to 3 "Modbus network input" in case of Flexible format (P046 is 6)

RX Apply the source selection parameters according the following table for the RX Option Board:

Table 14 Configuration of Source Selection RX Parameters

Param	Description	Setting
A001	Motor 1 Frequency Source	For Option Board as source: Set to 5 "Option Board Interface 2" for all assemblies except Flexible format (P046 is not 6)
A002	Motor 1 Run Command Source	Set to 3 "Modbus network input" in case of Flexible format (P046 is 6)

Step 7

Registers are used by the Inverter to adjust some Inverter function sources.

MX2 If required, adjust the selection parameter in accordance with the following table for MX2:

Table 15 Configuration of Other Selection MX2 Parameters

Param	Description	Setting
P033	Torque Command Source	For Option Board as source: Set to 6 "Option Board Interface" for all assemblies except Flexible format (P046 is not 6) Set to 3 "Digital Operator input" for Flexible format (P046 is 6)
P036	Torque Bias Mode	For Option Board as source: Set to 5 "Option Board Interface" for all assemblies except Flexible format (P046 is not 6) Set to 0 "Digital Operator input" for Flexible format (P046 is 6)
C021	Output Terminal 11 Source	Set to 63 for Option Board as source
C022	Output Terminal 12 Source	Set to 63 for Option Board as source
C026	Alarm Relay Source	Set to 63 for Option Board as source (optional)

RX If required, adjust the selection parameter in accordance with the following table for RX:

Table 16 Configuration of Other Selection RX Parameters

Param	Description	Setting
P033	Torque Command Source	For Option Board as source: Set to 7 "Option Board Interface 2" for all assemblies except Flexible format (P046 is not 6) Set to 3 "Digital Operator input" for Flexible format (P046 is 6)
P036	Torque Bias Mode	For Option Board as source: Set to 6 "Option Board Interface 2" for all assemblies except Flexible format (P046 is not 6) Set to 0 "Digital Operator input" for Flexible format (P046 is 6)
C021	Output Terminal 11 Source	Set to 63 for Option Board as source
C022	Output Terminal 12 Source	Set to 63 for Option Board as source
C023	Output Terminal 13 Source	Set to 63 for Option Board as source
C024	Output Terminal 14 Source	Set to 63 for Option Board as source
C025	Output Terminal 15 Source	Set to 63 for Option Board as source
C026	Alarm Relay Source	Set to 63 for Option Board as source (optional)

Step 8

The Flexible format (assembly 139/159) gives you the freedom to select any Inverter Modbus register for Cyclic Data Exchange. Inverter registers P160 to P167 and P170 to P177 are used to configure and map the exchanged Modbus registers. Please refer to *APPENDIX F Flexible Format* on page 91 for more detail.

Table 17 Configuration of Flexible Mapping

Param	Description	Setting
P160	Output Register 1 contents	Modbus register mapped into flexible output word 1
P161	Output Register 2 contents	Modbus register mapped into flexible output word 2

Table 17 Configuration of Flexible Mapping

Param	Description	Setting
P162	Output Register 3 contents	Modbus register mapped into flexible output word 3
P163	Output Register 4 contents	Modbus register mapped into flexible output word 4
P164	Output Register 5 contents	Modbus register mapped into flexible output word 5
P165	Output Register 6 contents	Modbus register mapped into flexible output word 6
P166	Output Register 7 contents	Modbus register mapped into flexible output word 7
P167	Output Register 8 contents	Modbus register mapped into flexible output word 8
P170	Input Register 1 contents	Modbus register mapped into flexible input word 1
P171	Input Register 2 contents	Modbus register mapped into flexible input word 2
P172	Input Register 3 contents	Modbus register mapped into flexible input word 3
P173	Input Register 4 contents	Modbus register mapped into flexible input word 4
P174	Input Register 5 contents	Modbus register mapped into flexible input word 5
P175	Input Register 6 contents	Modbus register mapped into flexible input word 6
P176	Input Register 7 contents	Modbus register mapped into flexible input word 7
P177	Input Register 8 contents	Modbus register mapped into flexible input word 8

Step 9

Restart the Inverter for the changes to take effect. See note 1 and 2.

Note 1 Alternative ways for configuring inverter parameters and resetting the inverter are:

- Use the OMRON CX-Drive tool, or
- Use CX-Integrator with the unit's EDS file (see *SECTION 4 Operations and Monitoring* on page 29), or
- Use Explicit messages to access the parameters directly (refer to *APPENDIX E CompoNet Explicit Messages* on page 83).

Note 2 When restarting the Inverter, wait for the Inverter power indicator to go out before switching on again. Note the time to wait may vary depending on the Inverter model.

 **Caution** Check the network related Inverter settings regarding CompoNet node address and other settings. Not doing so may result in unexpected operation.

The EDS file contains the access data for most of the Inverter's parameters. This enables CompoNet configurators such as CX-Integrator to configure the Inverter.

The defaults of the parameters have been selected specifically for the Option Board and not necessarily the same as the Inverter parameter's default value. Please note that the write access of the Inverter parameters may depend on the Inverter mode. Also make sure the Inverter is not in trip state before downloading the parameters.

- ⚠ WARNING** During the parameter initialization (Inverter parameter b180), operating the Inverter is not prevented automatically and doing so may lead to un predicted behavior.
Be sure to not operate the Inverter and do not write any Inverter parameter during the parameter initialization by Option Board or any other interface.

3-3 Configuring the Network

Communications are started just by connecting the communications wiring and turning ON the power (the communications power supply to the Slave Unit and the power supply to the PLC), allowing data to be shared between the I/O Memory Areas of the CPU Unit and the Slave Unit.

For details about configuring the OMRON CJ1W-CRM21 and CS1W-CRM21 Master Unit's, refer to CompoNet Unit Operation Manual (Cat. No. W456). The configuration can be done without the CompoNet configurator (CX-Integrator).

The output and input data of the slaves are allocated strictly in order of node address in the areas. The Master Unit will check the Default connection path of the actual Slave to select which assemblies will be used for the configuration.

- Step 1** Turn ON the communications, inverter(s), and Master Unit or PLC power supplies.
- Step 2** Confirm the Option Board's node number (rotary switches or inverter parameter P190) and Default Connection Path (inverter parameter P046) are set properly. See explanation in previous section.
- Step 3** In case one of the settings of the previous step is incorrect, change to the correct value and power OFF and ON the system.
- Step 4** Once the network is re-started with the new settings, check that the Option Board LED indicators indicate proper operation: If everything is correctly configured, both the MS (Module Status) LED and the NS (Network Status) LED will be Green. Please refer to *5-1 Troubleshooting Using the LED Indicators on page 39* for troubleshooting any configuration errors if the LED indicators are displaying a different pattern.
- Tip** In case of any errors during configuring the network, please refer to *SECTION 5 Troubleshooting and Maintenance on page 39*.
- Step 5** When the CompoNet network is operating properly, optionally the Master Unit provides the possibility to register the Slave Units.

3-4 Registration table

Registration Tables are used to register Slave Units that are intended to participate at particular node addresses to verify that they actually are participating. At the same time, they prevent unregistered Slave Units and Slave Units of the wrong models from participating in the network.

Perform the registration sequence of the Master Unit.

Master Registration Sequence

The registration sequence for a slave of non-default Input and/or Output size (2 words in/ 2 words out) requires a manual adaptation of the EDS file.

Perform the following steps to resolve this issue:

- Step 6** Determine the input and output size of the assembly chosen. This information can be found in *C-3 Assembly Object (Class 0x04) on page 73*.

As example, take for instance you have selected Extended Control IO and Multi-function input monitor (assemblies 101 and 153) by selecting P046 (Default Connection Path) = 5. The resulting output size is 8 bytes and input size is 10 bytes.

Step 7 Adapt the non-default sizes in the EDS file of the Unit you are configuring. The data to change can be found in the "[CompoNet_IO]" part.

For the example, the [CompoNet_IO] part will look like this (notice the length is in words instead of bytes):

```
[CompoNet_IO]
  CompoNet_Input_Info =
    2, $ Length unit: 0=bits, 1=bytes, 2=words
    5; $ Length
  CompoNet_Output_Info =
    2, $ Length unit: 0=bits, 1=bytes, 2=words
    4; $ Length
```

Step 8 Install the EDS file in CX-Integrator and perform the registration sequence of the Master Unit. Confirm the Registration table shows the correct input and output size.

If these steps are omitted, the CRM21 Master will fail to connect to the Slave at startup, indicating both error d5 (Verification error: non-existent Slave Unit) and d6 (Verification error: unregistered Slave Unit).

SECTION 4

Operations and Monitoring

This section provides some common usage examples to help you get started.

4-1 Setting up inverter

Unless otherwise specified, all usage examples make use of the Extended Speed IO format as the default connection path (Refer to section 3-1 *Installation of EDS files, Step 2*). Prepare the Inverter and Option Board before starting with the usage examples:

Step 1

Initialize the Inverter mode to Induction Motor, Constant Torque:

MX2

Set b049 = 0, b171 = 1 and then b180 = 1.

Refer to MX2 User's manual (Cat. No. I570) section 3-6-24.

RX

Set b049 = 0, b084 = 2 and then b180 = 1.

Refer to RX User's manual (Cat. No. I560) section 4-2 Parameter Initialization).

Step 2

Configure the Option Board and Network as explained in sections 3-1 *Installation of EDS files* and 3-2 *Configuring the Option Board* with Extended Speed IO (Output assembly 21, Input assembly 71).S (Default Connection Path)If you configured everything correctly, your output and input I/O words should contain the following data:

Table 14 Extended Speed I/O Output Words

Word	Bit Allocation							
	7	6	5	4	3	2	1	0
	15	14	13	12	11	10	9	8

Instance ID 21: Extended Speed Control Output									
n	-	REF	CTR	-	-	RST	REV	FWD	
	-	-	-	-	-	-	-	-	-
n + 1	Rotational Speed Reference (default [0.01 Hz])								
	Rotational Speed Reference								

Bit	Name	Description
FWD	Forward/Stop	0: Stop 1: Forward
REV	Reverse/Stop	0: Stop 1: Reverse
RST	Fault Reset	Reset Fault/Trip condition on transition from 0 to 1
CTR	NetCtrl	Run command selection. 0: Setting of A002 1: Network controlled
REF	NetRef	Speed reference selection. 0: Setting of A001 1: Network controlled

Table 15 Extended Speed I/O Input Words

Word	Bit Allocation							
	7	6	5	4	3	2	1	0
	15	14	13	12	11	10	9	8

Instance ID 71: Extended Speed Control Input									
n	ARF	RFN	CFN	RDY	DRR	DFR	WR	FLT	
	Drive Status (see below)								
n + 1	Rotational Speed Monitor (default [0.01 Hz])								
	Rotational Speed Monitor								

Bit	Name	Description
FLT	Fault	0: Normal 1: Fault/Trip
WR	Warning	0: Normal 1: Warning
DFR	During forward run	0: Stop/reverse 1: During forward run
DRR	During reverse run	0: Stop/forward 1: During reverse run
RDY	Inverter ready	0: Inverter not ready 1: Inverter ready
CFN	Ctrl from Net	Run command input selection 0: Local 1: CompoNet reference
RFN	Ref from Net	Speed reference input selection 0: Local 1: CompoNet reference
ARF	At reference	0: Accel/decel phase 1: At reference

Drive Status	
Value	Description
1	Startup
2	Not ready
3	Ready
4	Enabled
5	Stopping
6	Fault/Trip Stop
7	Faulted/Tripped



Caution

Check the Inverter settings for proper Inverter behavior before actually operating the Inverter remotely via the network.

⚠ Caution The product will be used to control an adjustable speed drive connected to high voltage sources and rotating machinery that is inherently dangerous if not operated safely. Interlock all energy sources, hazardous locations, and guards in order to restrict the exposure of personnel to hazards. The adjustable speed drive may start the motor without warning. Signs on the equipment installation must be posted to this effect. A familiarity with auto-restart settings is a requirement when controlling adjustable speed drives. Failure of external or ancillary components may cause intermittent system operation, i.e., the system may start the motor without warning or may not stop on command. Improperly designed or improperly installed system interlocks and permissions may render a motor unable to start or stop on command.

4-2 Operating the Motor

4-2-1 Starting the Motor

- Step 1**
- MX2** Set A001 = 4 and A002 = 4 for the MX2 Inverter, so that the Inverter can be controlled using the CompoNet Option Board.
 - RX** Set A001 = 5 and A002 = 5 for the RX Inverter, so that the Inverter can be controlled using the CompoNet Option Board.
- Note** The net control (CTR) and net reference (REF) override bits in the 1st output word can be used to override A001 and A002.
- When the CRT and REF override bits are set, it has the same effect as temporarily setting A001 and A002 to Inverter control. Clearing the CRT and REF bits removes the override, and the Inverter sources are once again determined by the A001 and A002 register values.
- MX2** In case the Inverter has version AAAA, override is not supported for A002=2. The change of control using the Option Board is not possible.
- Step 2** Set F002 and F003 for adjusting the acceleration and deceleration time of the motor. Refer to MX2 User's manual (Cat. No. I570) section B-4 or RX User's manual (Cat. No. I560) section 4.2.
- Step 3** Set the Rotation Speed Reference (see Appendix B) of the Inverter in the 2nd I/O output word to 10.00 Hz.
- Step 4** Set the FWD bit to put the Inverter in run mode. The RUN indicator on the Inverter should light up at this point. If this is not the case, check your source selection (please refer to section 3-2 step 5).
- The motor accelerates until it reaches the desired frequency. Notice that the ARF bit is set once the inverter has reached the desired Rotation Speed Reference.

4-2-2 Changing Direction

- Step 5** Clear the FWD bit and set the REV bit.
- The motor decelerates stops and then accelerates in the opposite direction. ARF bit clears as soon as the Rotation Speed Reference is changed. Once the new Rotation Speed Reference is reached, ARF bit is set again.

4-2-3 Stopping the Motor – Decelerated stop

- Step 6** Clear the run bits (FWD or REV) to bring the motor to a controlled (decelerated) stop.

The motor decelerates, and comes to a stop. ARF bit clears as soon as the run bit is cleared.

Before continuing set Rotation Speed Reference to 0 Hz.

Note The motor can also be brought to a stop by setting Rotation Speed Reference to 0 Hz and leaving the run bits set. The Inverter will however stay in run mode once the motor has reached 0 Hz.

4-2-4 Stopping the Motor – Free-running

An alternative to Clear the run bits (FWD or REV) to bring the motor to a controlled (decelerated) stop of step 6 is a free-run stop. The Inverter stops controlling the motor, and the motor coasts to a stop. Set C001 = 11 (FRS: free-run stop) to assign intelligent input terminal 1 as free-run stop enable. Restart the Inverter or reset the Option Board for the new settings to take effect. Set the terminal input 1 to ON to enable free-run stop. During a free-run stop, Rotation Speed Monitor immediately drops to 0 and ARF bit is cleared.

4-2-5 Changing Speed Reference and Speed Monitor Scaling

MX2 Rotational Speed Reference and Rotational Speed Monitor are word registers. The scaling of these values depend on the inverter's Motor poles setting P049:

1. In case P049 has non-zero value, the Unit is RPM.
2. In case P049 is set to zero, the Unit depends on the inverter mode. If the inverter is in High Frequency (HF) mode, the Unit is 0.1 Hz. The unit will be 0.01 Hz in other modes.

For the second option (Unit is either 0.1 Hz or 0.01 Hz), the maximum frequency which can be set is 400.00 Hz.

Please refer to MX2 User's manual (Cat. No. I570) for instructions about inverter modes and parameter P049.

RX Rotational Speed Reference and Rotational Speed Monitor are word registers. The scaling of these values depend on the inverter's Motor poles setting P049:

1. In case P049 has non-zero value, the Unit is RPM.
2. In case P049 is set to zero, the Unit is 0.01 Hz.

4-3 Overriding Inverter inputs

By using the Option Board's input override functionality, the Inverter Intelligent Terminal Functions can be controlled from the network.

The following example explains how to make use of the Option Board to override the input function Free Run Stop (FRS) using the IO data.

Step 1 Configure the Option Board and Network as explained in sections 3-1 *Installation of EDS files* on page 23 and 3-2 *Configuring the Option Board* on page 23 with Extended Control IO and Multi-function IO monitor (Output assembly 101, Input assembly 151). Select P046 (Default Connection Path) = 4.

Step 2 Set C003 = 11 (FRS: Free Run Stop) to assign intelligent input terminal 3.

Step 3 The output words of assembly 101 contain the CI3 bit (see table 16), which overrides input terminal 3. Set this bit to enable the free run stop.

MX2 Please note that as an alternative to override inputs using this assembly with bits CI3 to CI7, also the explicit message writing the Discrete Input Point Object (0x08) can be used. Please refer to *APPENDIX B Assembly Specification* on page 55 and *APPENDIX E CompoNet Explicit Messages* on page 83).

RX Please note that as an alternative to override inputs using this assembly with bits CI3 to CI8, also the explicit message writing the Discrete Input Point Object (0x08) can be used. Please refer to *APPENDIX B Assembly Specification* on page 55 and *APPENDIX E CompoNet Explicit Messages* on page 83).

4-4 Controlling Inverter Torque

In addition to Speed control, the MX2 Inverter and/or the RX Inverter allows direct control of the motor torque.

⚠ Caution Before following this example, disconnect your motor from any load to prevent injury or damage to property.

The following example explains how to make use of the Option Board to control the motor torque:

Step 1 Configure the Option Board and Network as explained in sections 3-1 *Installation of EDS files* and 3-2 *Configuring the Option Board* with Control IO and Multi function IO monitor (Output assembly 101, Input assembly 151). Select P046 (Default Connection Path) = 4.

Step 2 Set C003 = 52 (ATR: permission of torque command input) to assign intelligent input terminal 3 as torque enable. See also section 4-3 *Overriding Inverter inputs*

Step 3 Prepare the Inverter for torque mode:

- MX2** • Set parameter A044=3 to enable Sensorless Vector Control (SLV).
- RX** • Refer to section 4-3 of the RX User manual (I560) to set the torque mode.

Step 4 **MX2** Set parameter P033=6 to assign Torque command input selection to the Option Board Interface.

RX Set parameter P033=7 to assign Torque command input selection to the Option Board Interface 2.

Step 5 Restart the Inverter or reset the Option Board for the new settings to take effect.

Note The Inverter will only allow setting of torque related registers if it is configured to operate with CT rating in Std. IM mode.

Your input and output process words areas should now have the following layout:

Table 16 Extended Speed Torque I/O Output Words

RX only

Word	Bit Allocation							
	7	6	5	4	3	2	1	0
	15	14	13	12	11	10	9	8

Instance ID 101: Extended Speed and Torque Control Output								
n	CI8	CI7	CI6	CI5	CI4	CI3	REV	FWD
	CO2	CO1	CR	CO5	CO4	CO3	RST	FFL
n + 1	Rotational Speed Reference (default [0.01 Hz])							
	Rotational Speed Reference							
n + 2	Torque Reference [1 %]							
	Torque Reference							
n + 3	Torque Compensation Bias [1 %]							
	Torque Compensation Bias							

Bit	Name	Description
FWD	Forward/Stop	0: Stop 1: Forward
REV	Reverse/Stop	0: Stop 1: Reverse
RST	Fault Reset	Reset Fault/Trip condition on transition from 0 to 1
FFL	Force Fault	Force external fault/trip from network
CI3 to CI7	Control/Override Input	0: Reset 1: Set override for Multi Function input 3 to 7
CI8	Control/Override Input	0: Reset 1: Set override for Multi Function input 8
CR	Set Relay Output	0: Reset 1: Relay Output
CO1, CO2	Set Transistor Output	0: Reset 1: Set Multi Function 1 to 2
CO3 to CO5	Set Transistor Output	0: Reset 1: Set Multi Function 3 to 5

Table 17 Extended Speed Torque I/O Input Words

RX only

Word	Bit Allocation							
	7	6	5	4	3	2	1	0
	15	14	13	12	11	10	9	8

Instance ID 151: Extended Speed Control Input								
n	FLT	WR	RDY	ARF	-	DRR	DZS	DFR
n + 1	MO4	MO3	MO2	MO1	MR	CFN	-	-
n + 2	Torque actual [1%]							
n + 3	Output current monitor [0.1 A]							

Bit	Name	Description
DFR	During forward run	0: Stop/reverse 1: During forward run
DZS	During zero speed	0: Non-zero speed 1: During zero speed
DRR	During reverse run	0: Stop/forward 1: During reverse run
ARF	At reference	0: Accel/decel phase 1: At reference
RDY	Inverter ready	0: Inverter not ready 1: Inverter ready
WR	Warning	0: Normal 1: Warning
FLT	Fault	0: Normal 1: Fault/Trip
CFN	Control from net	Run command input selection 0: local 1: CompoNet
MO1, MO2	Monitor outputs	0: OFF 1: ON
MO3, MO4	Monitor outputs	0: OFF 1: ON
MR	Monitor Relay outputs	0: OFF 1: ON

- Step 6** Set the maximum allowable output frequency in torque mode by configuring P039 and P040 for the forward and reverse run directions. Be careful to select safe limits for your test setup.
- Step 7** Set the Rotation Speed Reference (see APPENDIX B Assembly Specification on page 55) of the Inverter in the 2nd I/O output word to 10.00 Hz.
- Step 8** Set the Torque Reference of the Inverter in the 3rd I/O output word to 20%.
- Step 9** Set the FWD bit to put the Inverter in run mode. The motor will accelerate to a constant forward output frequency.
- Step 10** Override the input terminal 3 (CI3) to enable torque command input.
The output torque is given by d012.
- Step 11** To change the torque command direction, clear the FWD bit and set the REV bit.

Note As an alternative for the overriding of input terminal 3 from the network at step 10, also the physical input terminal can be used.

4-5 Faults and Trips

4-5-1 External Trip

You may want to trip the Inverter from your PLC program. Not all assemblies support setting the external trip by using a bit in IO Data. Basically there are two options:

- Select an assembly which support this trip set in the output data.
- Using explicit message to set the Force Fault/Trip attribute in the Control Supervisor Object (Class 29 Hex, Instance 01 Hex, Attribute 11 Hex).

The two Extended Control IO assemblies (Output 101, Input 151) contains the FFL (Force Fault/Trip) bit and can be used for this feature.

- Step 1** Follow the instructions sections 3-1 Installation of EDS files and 3-2 Configuring the Option Board to configure the assemblies.
- Step 2** Set bit 8 (FFL) of the first word of the output data to trip the Inverter.

The alternative is to use the explicit message mechanism to generate the external trip. Please refer to *APPENDIX E CompoNet Explicit Messages* example 3 for a description how to do this.

4-5-2 Clearing a Trip

When the inverter trips due to a fault condition first analyse the trip cause as explained in section 5-1 *Troubleshooting Using the LED Indicators* on page 39 or section 5-3 *Maintenance and Inspection* on page 45.

Notice that the FLT bit is set (present in all output assemblies) when the Inverter trips.

⚠ WARNING In the event the Inverter is in a Trip state, be sure to investigate the cause of this Trip state thoroughly before clearing the Trip. Not checking the cause may result in unexpected operation.

Step 1 Please clear the FWD and REV bits in your PLC program when a rising edge is detected on FLT.

Step 2 Set the RST bit of the output assembly to clear the trip.

⚠ WARNING Always clear the run bits FWD and REV in your PLC program on the rising edge of the FLT bit. Not doing so may result in the motor starting unexpectedly when the trip is cleared via CompoNet or the „Stop/reset“ button on the Inverter

4-6 Accessing Parameters

CompoNet explicit messages sent from the Master Unit to the Option Board can be used to access any parameter from the Unit or the Inverter. Please refer to the *APPENDIX E CompoNet Explicit Messages* for details and examples.

Refer to the CompoNet Master Units Operation manual (Cat. No. W456) for details on how to send the explicit messages to the Option Board. Below are examples for usage of the OMRON CJ1W-CRM21 Master Unit with the FINS Explicit Message Send command (2802).

4-6-1 Accessing General (AC Drive Profile) Objects

Reading the value of Inverter input terminal [4].

Command:

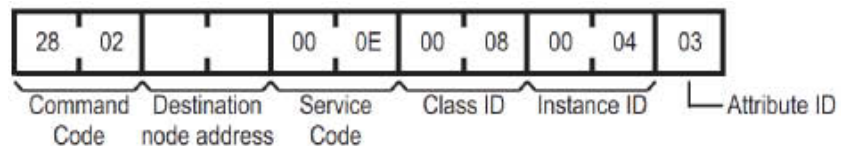

Response:

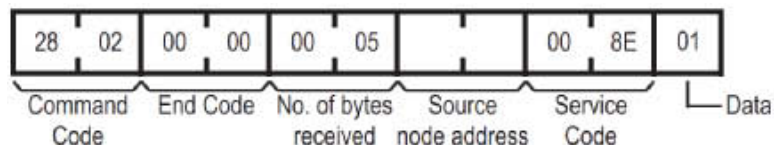

The value of input terminal [4] is ON.

4-6-2 Accessing Inverter parameter using Function Code Object

Writing the value of the acceleration time (F002) to 3.00 seconds (012C Hex). The parameter F002 corresponds to address 5002 (138A Hex). Please note the swapping of the data following CIP data type encoding.

Command:

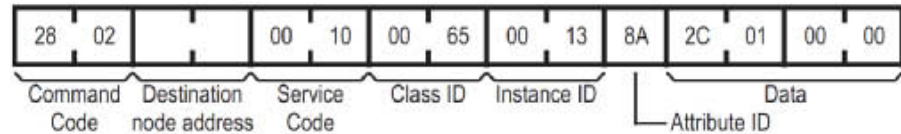

Response:

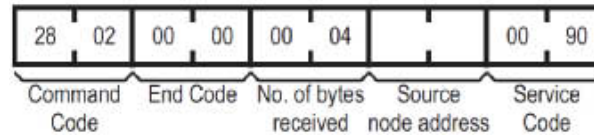

4-7 Flexible Format

The Flexible format lets you operate the Inverter using the Modbus registers directly. For CompoNet, the maximum of 8 words can be freely configured by the user. Parameters P160 to P167 and P170 to P177 are used to map Modbus registers into the cyclically exchanged IO data. User parameters P160 to P167 configure the output data words where parameters P170 to P177 configure the input data words.

Please refer to the *APPENDIX F Flexible Format* on page 91 for details on the flexible mode.

4-7-1 Typical Configuration

- Step 1** Configure the Option Board and Network as explained in sections *3-1 Installation of EDS files* and *3-2 Configuring the Option Board*.
- Step 2** Set parameters P160 to 1F01h to map coil data 0 as the first output word.
- Step 3** Set parameters P161 and P162 to 0001h and 0002h to map the Modbus frequency reference (F001) as the 2nd and 3rd output words.
- Step 4** Set parameter P170 to 0005h to map Inverter status C as the first input word.
- Step 5** Set parameter P171 to 1E01h to map coil data 1 (coil no 0010h to 001Fh) into the second input word.
- Step 6** Set parameters P172 and P173 to 1001h and 1002h to map the Modbus frequency monitor (d001) as the third and fourth input word.
- Step 7** Restart the Inverter or reset the Option Board for the new settings to take effect.

If you configured everything correctly, your output and input words should have the following mapping:

Table 18 Flex Mode Output Area with Typical Configuration

Word offset	+0	+1	+2	+3	+4	+5	+6	+7
Register	Coil data 0	F001 (0001h/0002h)	-	-	-	-	-	-
Value	dec	0	0	0	0	0	0	0
	hex	0000	0000	0000	0000	0000	0000	0000

Bit	15	14	13	12	11	10	9	8	7	6	5	4	3	2	1	0
Name	-	In8 ^{RX}	In7	In6	In5	In4	In3	In2	In1	-	-	RS	EXT	Dir	Opr	-
Value	0	0	0	0	0	0	0	0	0	0	0	0	0	0	0	0

Opr	Operation command	In3	Intelligent input terminal [3]
Dir	Rotation direction command	In4	Intelligent input terminal [4]
EXT	External Trip	In5	Intelligent input terminal [5]
RS	Trip reset	In6	Intelligent input terminal [6]
In1	Intelligent input terminal [1]	In7	Intelligent input terminal [7]
In2	Intelligent input terminal [2]	In8 ^{RX}	Intelligent input terminal [8] ^{RX}

Note See Note BIT 15 below

^{RX}: Is only applicable for the RX Inverter

Note Do not set bit 15 of the Coil data 0 Output to ON. The operation status coil (000Fh) cannot be used in the output process area.

Table 19 Flex Mode Input Area with Typical Configuration

Word offset	+0	+1	+2	+3	+4	+5	+6	+7
Register	Invstat C	Coil data 1	d001 (1001h/1002h)	-	-	-	-	-
Value	dec	1	2	0	0	0	0	0
	hex	0001	0002	0000	0000	0000	0000	0000

Bit	15	14	13	12	11	10	9	8	7	6	5	4	3	2	1	0
Name	ONT	RNT	TRQ	UV	-	OTQ	FA3	AL	OD	OL	FA2	FA1	RUN	-	Rdy	Dir
Value	0	0	0	0	0	0	0	0	0	0	0	0	0	0	1	0

Dir	Rotation direction	AL	Alarm signal
Rdy	Inverter ready	FA3	Set frequency reached
RUN	Running	OTQ	Over-torque
FA1	Constant-speed reached	UV	Undervoltage
FA2	Set frequency overreached	TRQ	Torque limited
OL	Overload advance notice	RNT	Operation time over
OD	Output deviation for PID control	ONT	Plug-in time over

Invstat C MX2: Inverter status C (Refer to Inverter Manual section B-4-2)
 RX : Inverter status C (Refer to Inverter Manual section 4-4 Communication Function)

Confirm the Output has a data size of 3 words and the Input has 4 words. This is because P163 to P167 and P174 to P177 are all set to zero.

4-7-2 Operating the Motor

- Step 8** Set A001 = 3 and A002 = 3 so that the Inverter can be controlled using the Modbus registers in Flexible mode.
- Step 9** Set the Opr bit to put the Inverter in run mode. The RUN indicator on the Inverter should light up at this point. If this is not the case, check your source selection.
- Step 10** Change F001 in the Output data to the desired frequency (E.g. 1000 for 10.00 Hz)

Table 20 Flex Mode Output Area with Motor Running Forward

Word offset	+0	+1	+2	+3	+4	+5	+6	+7
Register	Coil data 0	F001 (0001h/0002h)		-	-	-	-	-
Value	dec	2	+1000		0	0	0	0
	hex	0002	0000	03E8	0000	0000	0000	0000

Bit	15	14	13	12	11	10	9	8	7	6	5	4	3	2	1	0
Name	-	In8 ^{TRQ}	In7	In6	In5	In4	In3	In2	In1	-	-	RS	EXT	Dir	Opr	-
Value	0	0	0	0	0	0	0	0	0	0	0	0	0	0	1	0

The motor accelerates until it reaches the desired frequency. Notice that the FA1 bit is set once the inverter has reached the desired reference frequency.

Table 21 Flex Mode Input Area with Motor Running Forward

Word offset	+0	+1	+2	+3	+4	+5	+6	+7
Register	Invstat A	Coil data 1	d001 (1001h/1002h)		-	-	-	-
Value	dec	3	26	+1000		0	0	0
	hex	0003	001A	0000	03E8	0000	0000	0000

Bit	15	14	13	12	11	10	9	8	7	6	5	4	3	2	1	0
Name	ONT	RNT	TRQ	UV	-	OTQ	FA3	AL	OD	OL	FA2	FA1	RUN	-	Rdy	Dir
Value	0	0	0	0	0	0	0	0	0	0	0	1	1	0	1	0

Step 11

Set Dir to reverse the direction of the motor. The motor decelerates, stops and then accelerates in the opposite direction. The FA1 bit clears as soon as the reference frequency is changed. Once the new reference frequency is reached, the FA1 bit is once again set.

Step 12

Clear the Opr bit to stop the motor. The motor decelerates and comes to a halt.

4-7-3 Faults and Trips

User trips can be generated by setting the EXT bit in coil data 0. You must always immediately clear the Opr bit in your PLC program when the Unit indicates it is in Trip status (for example when AL bit is set ON). If the Opr bit is set when the trip condition is cleared, the Inverter will immediately start running!

! WARNING

Always clear the Opr bit in your PLC program when the AL bit is set ON by the Inverter. Not doing so may result in the motor starting unexpectedly when the trip is cleared.

Set and clear the RS bit in coil data 0 to clear a trip.

! WARNING

Always clear the RS bit after setting it. Not doing so will result in new trip conditions automatically being cleared.

4-8 Limitations Caused by Inverter Mode and Rating Selection

MX2 The Inverter mode and rating selection directly affects several aspects of the Option Board usage. Refer to the MX2 User's manual section 3-6-24. The following table lists the most common consequences of the various Inverter modes and ratings:

Table 22 Limitations Caused by Inverter Mode and Rating Selection MX2

Inverter Mode and Rating	Standard Induction Motor		High Frequency	Permanent Magnet
	Constant Torque	Variable Torque		
d060	0 (1-C)	1 (1-v)	2 (H-1)	3 (P)
Rotational speed scaling	0.01 Hz		0.1 Hz	0.01 Hz
Torque-related registers	Available	Not available (see note)		

Note The Inverter will trip due to a cyclic mapping fault if you use torque-related registers in the process area when not available.

RX The Inverter mode and rating selection directly affects several aspects of the Option Board usage. Refer to the RX User's manual section 4-2. The following table lists the most common consequences of the various Inverter modes and ratings:

Table 23 Limitations Caused by Inverter Mode and Rating Selection RX

Inverter Mode and Rating	Standard Induction Motor	
	Constant Torque	Variable Torque
d060	0 (1-C)	1 (1-v)
Rotational speed scaling	0.01 Hz	
Torque-related registers	Available	Not available (see note)

Note The Inverter will trip due to a cyclic mapping fault if you use torque-related registers in the process area when not available.

SECTION 5

Troubleshooting and Maintenance

5-1 Troubleshooting Using the LED Indicators

The Option Board provide information about the network mode and network status by LED indicators.

The RX Digital Operator Display and RX Option Board shows similar information.

MX2
 - Digital Operator Display
 - Option Board

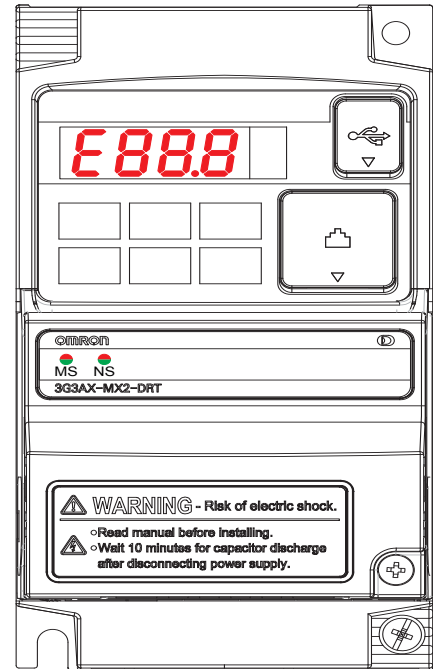

5-1-1 When an error occurs

When an error occurs, the Option Board trips the Inverter.

Step 1

MX2

At the MX2 Inverter, an error code is displayed on the Digital Operator Display.

RX

At the RX Inverter, you need to connect the Digital Operator Display to the Inverter with an Ethernet cable. Then you can see the error code on the display. Note: if despite the problem it is still possible to communicate with the unit, the latest error code can also be read in parameter d081.

Step 2

Use the error code to help troubleshoot the error.

In the following sections typical LED indicator and four-digit Inverter display patterns are provided to assist in troubleshooting. To show the status of the indicators, the following conventions are used:

○ MS	OFF	○ MS	Not important (Ignore)
● MS	RED	E60.1	Inverter error code
● MS	GREEN	000	Not important (Ignore)
⚡ MS	Flashing		

Tip

Do not clear the trip before you are finished troubleshooting an error. When you clear the trip, the error code is cleared from the four-digit display. You may therefore lose the error information before you are able to start troubleshooting. Checking data in trip history is still an option in this case.

5-1-2 Option Board or Inverter Errors



During the Initialization process the MS and NS indicator shortly light GREEN and RED to show correct operation of the indicator. Once the initialization has been completed correctly, the MS indicator will light GREEN and the NS indicator will be OFF. The table below shows the indicator and display patterns caused by Option Board or Inverter Errors.

Table 24 Option Board or Inverter Errors on the Inverter

MX2 Display & Indicators	RX Display & Indicators	Possible Cause(s)	Corrective Action
		The Inverter does not power up.	MX2 Follow the instruction provided in the MX2 User's manual (Cat. No. I570) section 6-1-4 or to troubleshoot. RX Follow the instruction provided in the RX User's manual (Cat. No. I560) section 5-1 to troubleshoot.
		The Option Board connector is damaged	1. Replace the Option Board.
		The Inverter RS input is ON	1. Switch the Inverter RS input OFF.
		The Option Board encountered a fatal error during Power-on	1. Check if the Option Board is mounted properly. 2. Restart the Option Board. 3. If the problem persists, replace the Option Board.
		The Inverter does not support the Option Board (Refer to section 5-1-3 Configuration Errors)	1. Replace the Inverter with a later version.
		The Option Board connector is damaged	1. Replace the Option Board.
		The Option Board encountered a fatal error during Operation.	1. Check if the option is mounted properly. 2. Restart the Option Board. 3. If the problem persists, replace the Option Board
		The Inverter is tripped with the Force external Fault/Trip through the fieldbus.	1. Clear the FFL Force external fault bit. 2. Reset the trip.
		The Inverter detected a fatal error in the operation of the Option Board.	1. Check if the option is mounted properly; 2. Restart the Option Board. 3. If the problem persists, replace the Option Board

5-1-3 Configuration Errors



If the Option Board is correctly configured, the MS indicator will light GREEN. The table below shows the indicator and display patterns caused by configuration errors.

Table 25 Configuration Errors on the Inverter





MX2 Display & Indicators	RX Display & Indicators	Possible Cause(s)	Corrective Action
		<p>One of the configuration parameters P160 – P179 has been rejected by the Inverter.</p>	<p>Check (and correct) the following items:</p> <p>STEP I:</p> <ul style="list-style-type: none"> • Does one of the parameters P168, P169, P178 or P179 contain a value which is not zero? • Is one of the parameters P160 to P167 or P170 to P177 specifying a Modbus register that does not exist? • If one of the parameters P160 to P167 is specifying a double-word Modbus register: Are both the low- and high-words specified in sequence by two consecutive parameters? • If one of the parameters P170 to P177 is specifying a double-word Modbus register: Are both the high- and low-words specified in sequence by two consecutive parameters? • Is a specific Modbus register specified twice in the output parameter registers P160 to P167? • Is one of the output parameters P160 to P167 specifying a Modbus register that is read only? <p>MX2 A register is read-only if it has an 'R' in the 'R/W' column in section B-4-2 of the MX2 User's manual (Cat. No. I570).</p> <p>RX A register is read-only if it has an 'R' in the 'R/W' column of the register list in section 4-4 of the RX User's manual (Cat. No. I560). <ul style="list-style-type: none"> • Is one of the output parameters P160 to P167 specifying a Modbus register of which the parameter is not run-mode editable? <p>MX2 A parameter is not run-mode editable if it has an 'x' in the 'Run Mode Edit' column in section 3 of the MX2 User's manual.</p> <p>RX A parameter is not run-mode editable if it has an 'No' in the 'Change during operation' column in Appendix 1 of the RX User's manual.</p> <p>STEP II:</p> <p>Restart the system by one of the following methods:</p> <ul style="list-style-type: none"> • Power OFF and ON • Press the stop button on the Operator panel. • Use the RS function of the intelligent input terminal. <p>Recovery via the fieldbus:</p> <ul style="list-style-type: none"> • Use Modbus Class Object to set the Trip reset coil (04h) in coil register 0x1F01. </p>

Table 25 Configuration Errors on the Inverter (continued)

MX2 Display & Indicators	RX Display & Indicators	Possible Cause(s)	Corrective Action
 <p>E65. MS NS</p>	 <p>E75. MS NS</p>	<p>Your Inverter settings are not compatible with this version of the Option Board.</p>	<ol style="list-style-type: none"> 1. Check P046 value in range [0..7]; 2. Restart unit; 3. Reset the Inverter to factory defaults; 4. If the problem persists, contact your local OMRON representative for assistance.

5-1-4 CompoNet Errors



If the CompoNet master is correctly configured and there are no wiring errors, the NS indicator will lit GREEN. The table below shows the indicator patterns caused by configuration CompoNet errors.

Table 26 CompoNet Errors on the Inverter

MX2 Display & Indicators	RX Display & Indicators	Possible Cause(s)	Corrective Action
		Waiting for connection	In case the Master Unit is using the Registration table functionality: Does the Registration table have correct input and output assembly length (check in CX-Integrator)? If not, perform sequence as defined in <i>Section 3-3 Configuring the Network</i> .
		Device Node address (P190) does not match current online address of the Unit.	1. Restart the Unit.
		The CompoNet master cannot communicate with the Option Board because the node address is already in use.	<ul style="list-style-type: none"> • Check (and correct) the following items: • Does a Slave Unit on the CompoNet network also have the same node address?
		The Option Board detects: communication idle or communication timeout during RUN mode (P044).	<ul style="list-style-type: none"> • Check (and correct) the following items: • Is the CompoNet master sending IDLE messages? Check P048 to select the Action on Network Idle. • Increase the value of P044, the timeout value.
		Connection time-out. The Option Board detects communication lost.	Check (and correct) the following items: <ul style="list-style-type: none"> • Is the ground cable of the Option Board connected with a ground terminal of the Inverter? • Are the installation guidelines to comply with EMC recommendations properly implemented? <p>MX2 MX2: refer to MX2 User's manual (Cat. No. I570) section D-1</p> <p>RX RX: refer to RX User's manual (Cat. No. I560) section D-2</p> <ul style="list-style-type: none"> • Are you using the correct cable type? • Is noise interference excessive? • Are the correct pins wired on the CompoNet connector? • Are there any short circuits or line interruptions?

5-1-5 Commissioning Mode

When using one of the OMRON tools during commissioning time, the Option Board can be set into commissioning mode. A clear indication will be given by the tool.

Commissioning mode is NOT an error, but it can influence normal system operation. During commissioning mode, Inverter parameter access takes priority over cyclic data exchange. Accessing Inverter parameters will therefore delay cyclic data exchange causing unexpected latencies.

 **Caution** Make sure that commissioning mode is disabled before operating the system.

5-2 Other Error Causes and Error Procedures

This section explains about errors which are not shown as specific LED indicator states.

Table 27 Other errors

Error event	Possible cause and procedure
Within CX-Integrator, the download or upload of the parameters of the Unit fail.	The Inverter may have limited write access to the parameters based on the Inverter mode selected. The Inverter may be in Trip state, which prevents parameters to be downloaded. Check the proper Inverter mode and state before attempting downloading again.
Explicit message access of the parameters (using Function Code object or Modbus Register object) fail.	The Inverter may have limited write access to the parameters based on the Inverter mode selected. The Inverter may be in Trip state, which prevents parameters to be downloaded. Check the proper Inverter mode and state before attempting downloading again.

5-3 Maintenance and Inspection

5-3-1 How to replace the MX2 Option Board

⚠ HIGH VOLTAGE Always Switch OFF the mains power supply to the Inverter before removing the Option Board. Wait for the time specified on the Inverter front cover for the capacitors to discharge. Not doing so may result in electrical shock.

Step 1 **MX2** Loosen the faulty Option Board mounting screw.

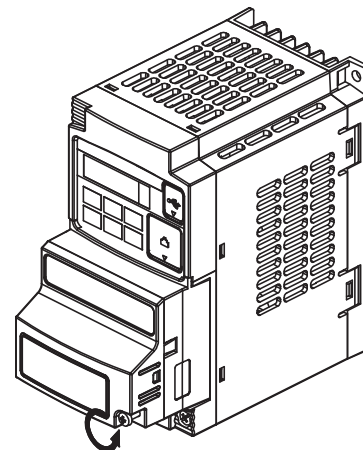

Step 2 **MX2** Pull the faulty Option Board straight out of the Inverter while pushing down on the indicated sides to release the snap-fits.

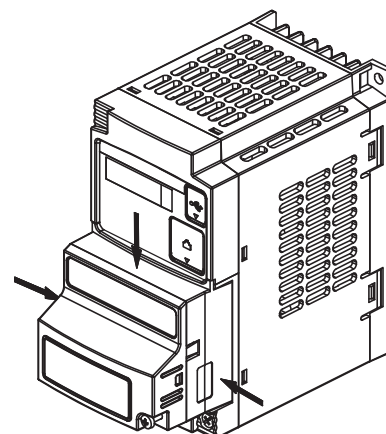

Step 3 **MX2** For Inverters up to 4.0 kW only: loosen the screw(s) of the terminal block cover and remove the cover to enable access to the chassis ground terminal screws.

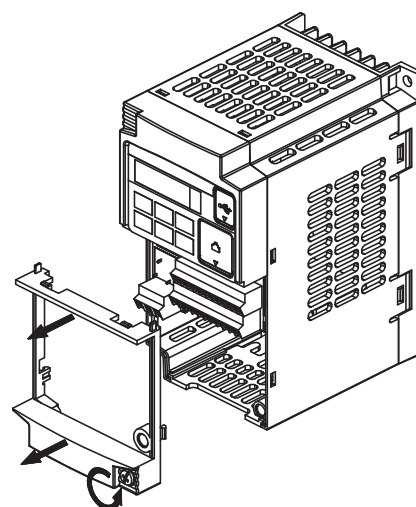

Step 4

MX2 Unscrew and remove the faulty Option Board grounding cable. Keep the screw and washers, but set the faulty Option Board aside.

1-phase 200 V 0.1 - 2.2 kW
 3-phase 200 V 0.1 - 3.7 kW
 3-phase 400 V 0.4 - 4.0 kW

3-phase 200 V 5.5 - 15 kW
 3-phase 400 V 5.5 - 15 kW

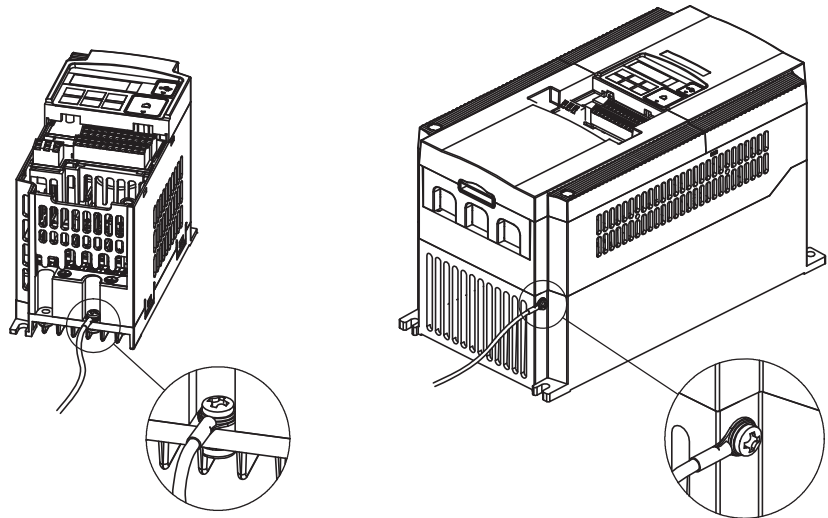

Step 5

MX2 Secure the replacement Option Board grounding cable to the Inverter using the mounting screw.

Unscrew and remove the faulty Option Board grounding cable.
 Keep the screw and washers, but set the faulty Option Board aside.

Step 6

MX2 If removed in Step 3, mount the terminal cover again and tighten the screw(s).

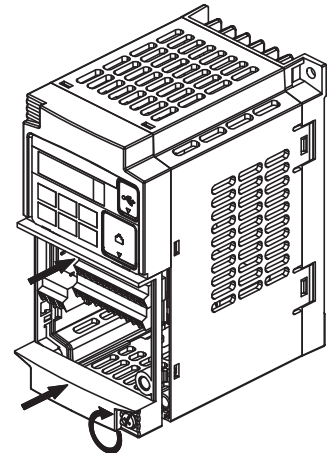

Step 7

MX2 Push the replacement Option Board into Inverter to replace the removed Option Board until it clicks into place

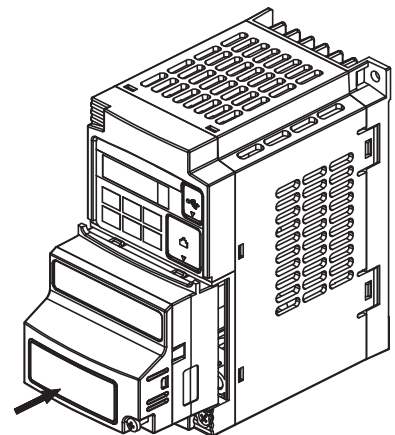

Step 8

MX2 Press down on the indicated corner of the replacement Option Board housing to ensure proper connection of the Option Board connector

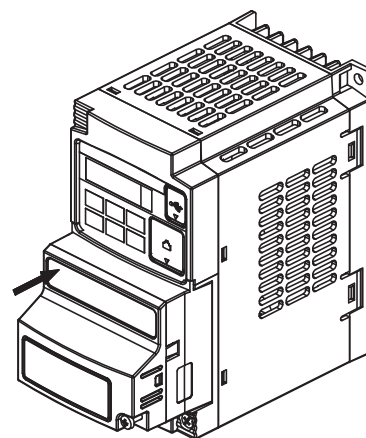

Step 9

MX2 Check that there is no gap between the top edges of the replacement Option Board and the Inverter casing.

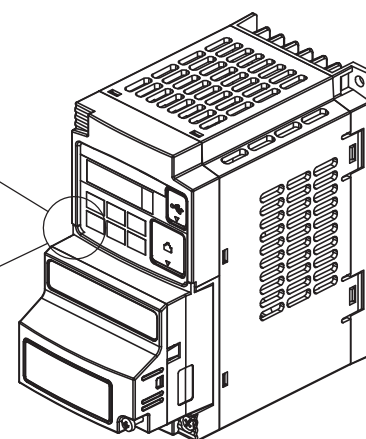
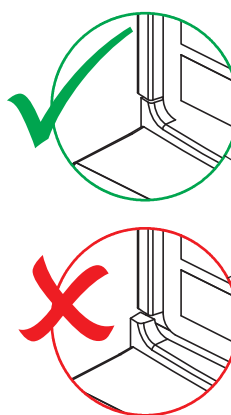

Step 10

MX2 Secure the replacement Option Board in place with the mounting screw (do not over-tighten).

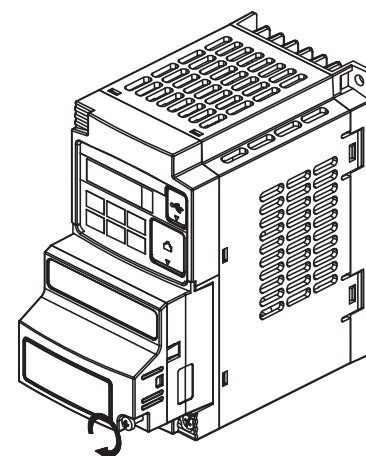

Caution When replacing an Inverter be sure that all Inverter settings of the Inverter being replaced are restored to the replacement.

5-3-2 How to replace the RX Option Board

⚠ HIGH VOLTAGE Always Switch OFF the mains power supply to the Inverter before removing the Option Board. Wait for the time specified on the Inverter front cover for the capacitors to discharge. Not doing so may result in electrical shock.

Step 1 **RX** Remove the blind cover by pushing the lip on the top

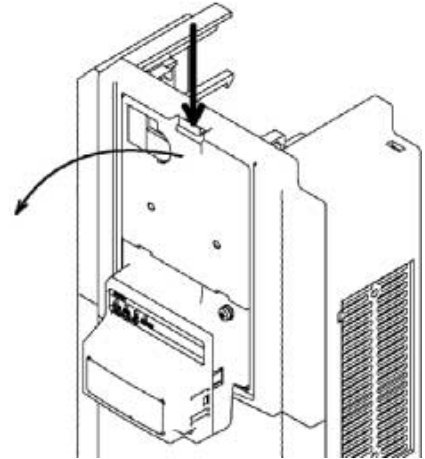

Step 2 **RX** Unscrew the screw on the top-right of the Option Board.

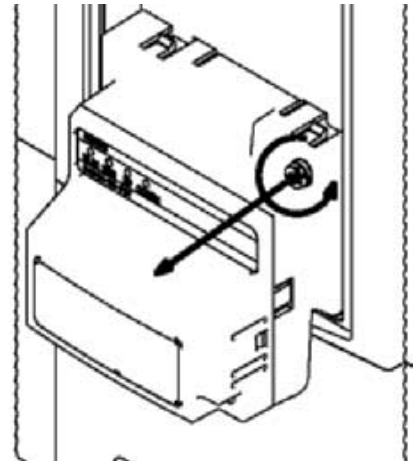

Step 3 **RX** Remove the Terminal cover from the inverter.

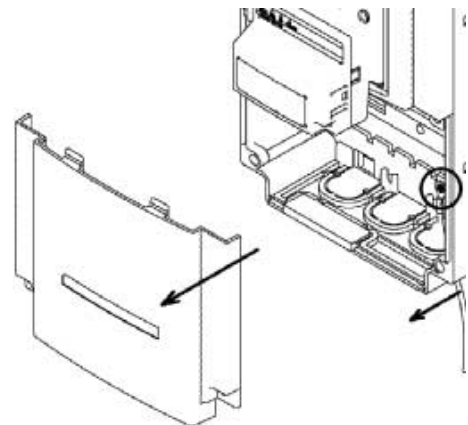

Step 4

RX Unscrew the Option Board grounding cable, mounted with an Inverter grounding bold.

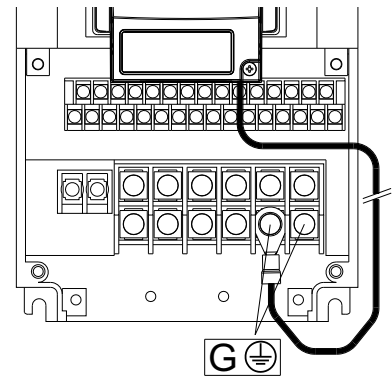

Step 5

RX Gently pull the Option Board straight out while pushing down on the indicated spots to release the snap-fits.. Be careful not to stress the flex cable

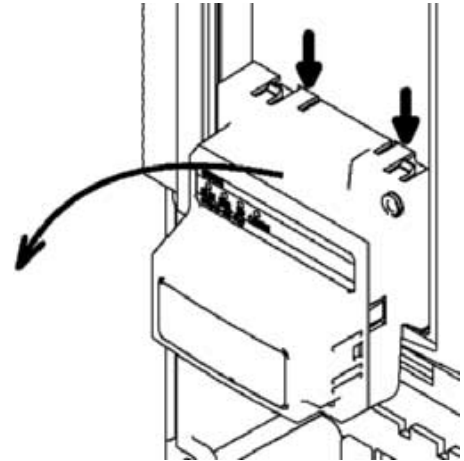

Step 6

RX Remove the flex cable from the inverter by pulling on the indicated locations.

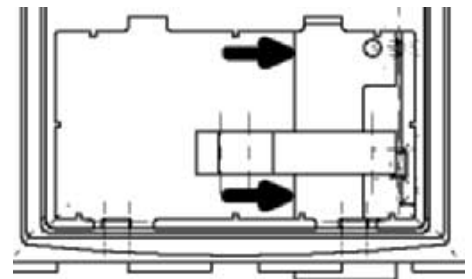

Step 7

RX Purpose: mount the new Inverter Connector (no.1) of the Option Board onto the interface connector (no.5) of the RX Inverter.

How to do:

First align the small hole of the Inverter connector (no.2) with the guide-post (no.4) in the Inverter.

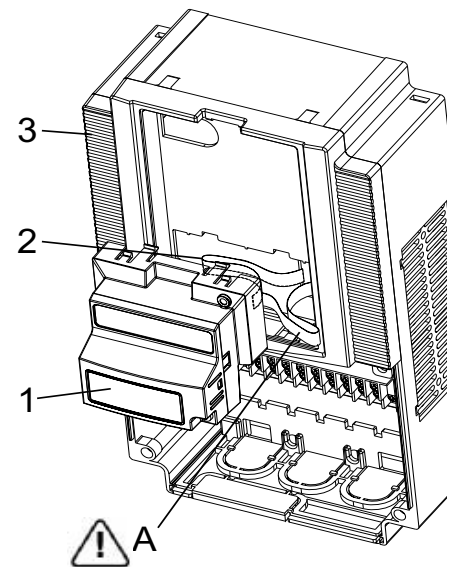

Then align the larger hole on the Inverter connector (no.3) with the threaded hole (no.6) in the Inverter. Push the Inverter connector into place.

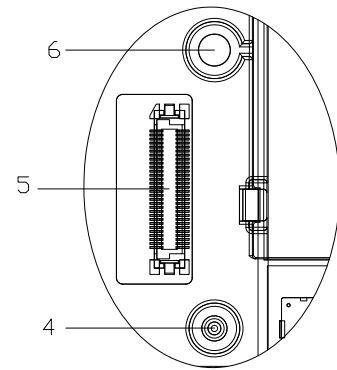

Step 8

RX Move the Option Board Cable (no.2) to the left with your finger, so the Option Board Cable is not pinched between the Option Board and the Inverter Front Cover.

Note Prevent a pinched Option Board Cable, as shown in position A.

Note Do not pull on the Option Board Cable.

Note Do not let the Option Board hang on the Option Board Cable.

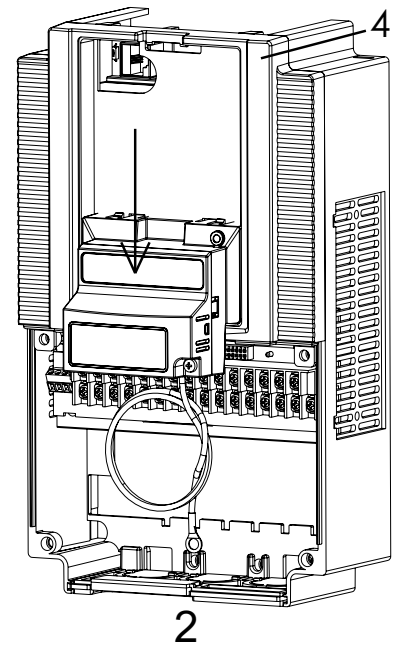
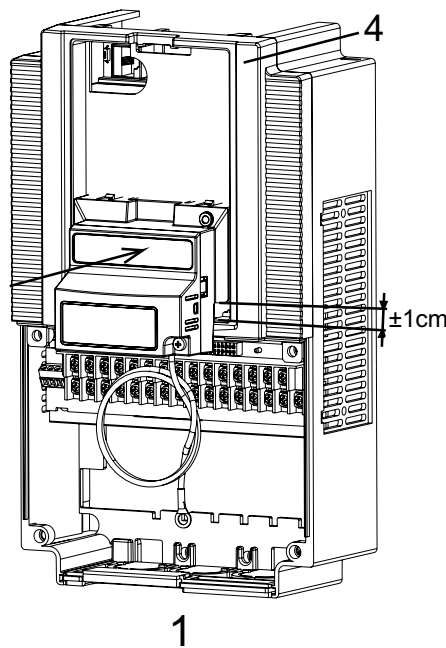

Insert the Option Board approximately 1 cm above the down-position into the Front cover of the Inverter. See figure 1 above.

Slide the Option Board down. See figure 2 above.

The snap-fits of the Option Board (no.5) will be locked by the snap-fits in the Front cover (no.4).

Option Board bottom side

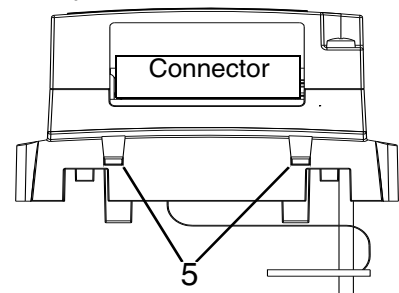

Step 9

RX Press down carefully the two locking pins (no. 1) of the Option Board.

Press carefully the top of the Option Board in the Inverter.

Check the Option Board is being locked by the locking pins (no.1).

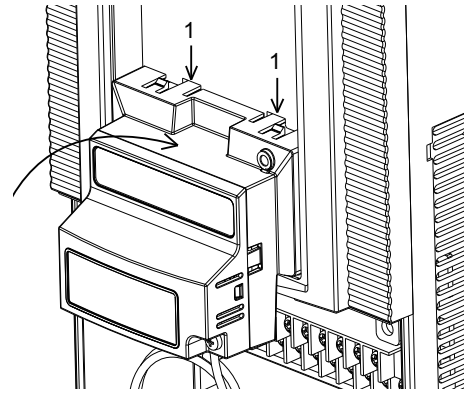

Step 10

RX Insert the screw (no. 1) into the upper right hole in the Option Board (no.2).

Tighten the screw into place (do not over tighten).

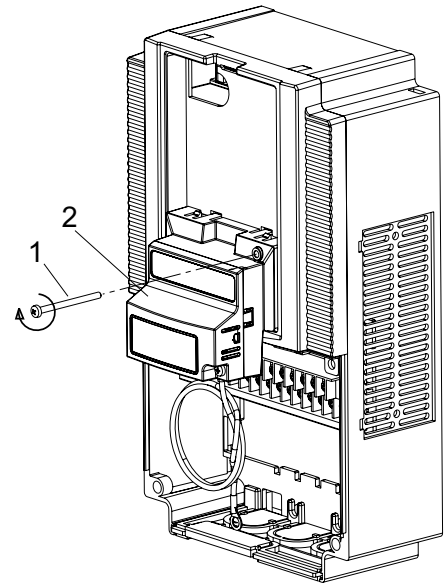

RX Fix the Option Board grounding cable to the chassis ground of the RX-Inverter under an already fixed chassis grounding bolt.

See the bold with the grounding figure.

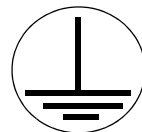

The position of the chassis ground vary from inverter type. Illustrations are only provided for one Inverter size. The instructions however are generic and may be followed for all Inverter sizes.

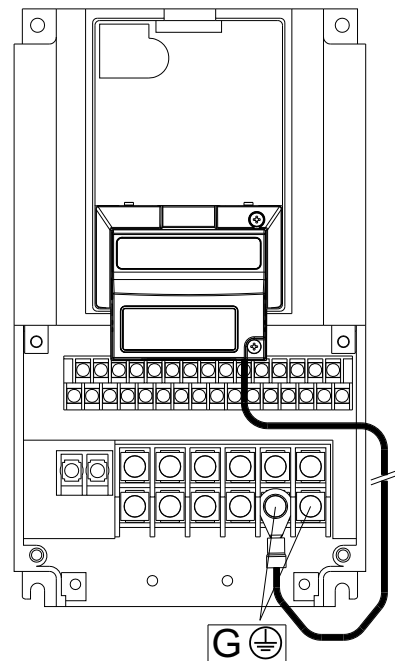

Step 11

RX Unscrew the mounting screws of the Terminal cover nearly completely from the plastic rings (no.1).

Remount the Terminal cover under the Option Board onto the Inverter (no.2).

Tighten the two screws (no.1).

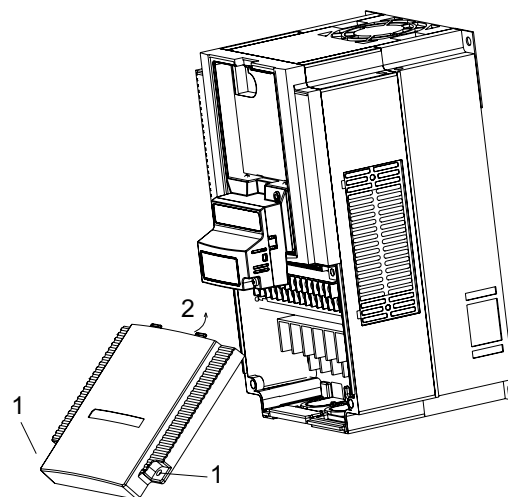

Step 12

RX Push the blind cover (no.1) into place.

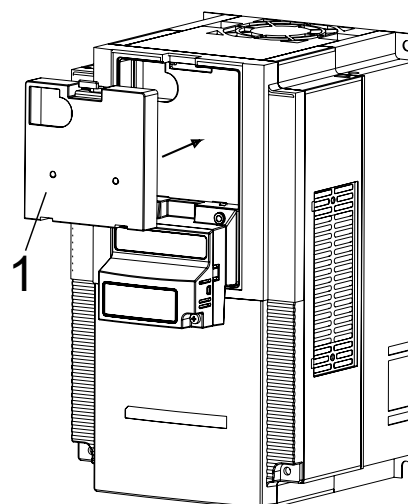

Note Refer to section 2 in the RX User's Manual (Cat. No. I560) for operations related to assembly and disassembly of the RX Inverter.

APPENDIX A

Glossary

Bit Slave Units	Bit Slave Units are Slave Units that are allocated units of 2 bits in I/O memory of the CPU Unit. Bit Slave Units provide 2 or 4 digital contact I/O points and have Standard or Sheathed Flat Cable already connected.
Electronic Data Sheet (EDS) Files	Text files which are used by network configuration tools such as CX-Integrator to configure the system. The configuration consists of CompoNet network related settings and may contain additional configurable parameters.
Explicit Messaging	Explicit messages are acyclic communication messages used for configuration or monitoring the devices over CompoNet
Inverter	A device that electronically changes DC to AC current through an alternating process of switching the input to the output, inverted and non-inverted. It contains three inverter circuits to generate 3-phase output to the motor.
Registration Table	<p>Master Unit's Registration Table containing Slave Unit data (i.e., the node address and corresponding Slave Unit model number) of each registered Slave Unit.</p> <p>This table can be registered from the CX-Integrator to verify the Slave Units actually participating in the network and prevent unregistered Slave Units from participating in the network.</p>
Repeater Units	Units that can be used to expand the network by extending trunk lines or branching.
Torque	The rotational force exerted by a motor shaft. The units of measurement consist of the distance (radius from shaft center axis) and force (weight) applied at that distance. Units are usually given as pound-feet, ounce-inches, or Newton-meters.
Trip event	An event that causes the inverter to stop operation is called a "trip" event (as in tripping a circuit breaker). The inverter keeps a history log of trip events. They also require an action to clear.
Word Slave Units	Word Slave Units are Slave Units that are allocated units of 16 bits (i.e., 1 word) in I/O memory of the CPU Unit.

APPENDIX B Assembly Specification

B-1 Basic Speed Control IO (20/70)

Assembly ID 20: Basic Speed Control Output

Table B-1 Basic Speed Control Output - Assembly 20 Allocation

Word	Byte	Bit Allocation							
		Bit 7	Bit 6	Bit 5	Bit 4	Bit 3	Bit 2	Bit 1	Bit 0
n	0	-	-	-	-	-	RST	-	FWD
	1	-	-	-	-	-	-	-	-
n + 1	2	Rotational Speed Reference (Low Byte)							
	3	Rotational Speed Reference (High Byte)							

Table B-2 Basic Speed Control Output - Assembly 20 Description

Name	Description
FWD	Forward run command 0: Stop 1: Forward run
RST	Fault reset Reset fault / trip condition on transition from 0 to 1
Rotational Speed Reference	Reference rotational speed. Unit: [RPM]/[0.1 Hz]/[0.01 Hz]. MX2 If Motor poles setting for RPM (inverter parameter P049) is set to zero, the Unit depends on the inverter mode (d060): d060 = 2 (High Frequency mode): Unit is [0.1 Hz] d060 != 2 (High Frequency mode): Unit is [0.01 Hz] RX If Motor poles setting for RPM (inverter parameter P049) is set to zero, the Unit is [0.01 Hz].

Note For safety reasons, the FWD, REV and RST command operation requires a rising edge (0 to 1 transition) after power on and fault/trip reset.

Assembly ID 70: Basic Speed Control Input

Table B-3 Basic Speed Control Input - Assembly 70 Allocation

Word	Byte	Bit Allocation							
		Bit 7	Bit 6	Bit 5	Bit 4	Bit 3	Bit 2	Bit 1	Bit 0
n	0	-	-	-	-	-	DFR	-	FLT
	1	-	-	-	-	-	-	-	-
n + 1	2	Rotational Speed Monitor (Low Byte)							
	3	Rotational Speed Monitor (High Byte)							

Table B-4 Basic Speed Control Input - Assembly 70 Description

Name	Description
FLT	Fault 0: Normal 1: Fault/trip

Table B-4 Basic Speed Control Input - Assembly 70 Description (continued)

Name	Description
DFR	During forward run 0: Stop/reverse 1: During forward run
Rotational Speed Monitor	Actual rotational speed monitor. Unit: [RPM]/[0.1 Hz]/[0.01 Hz]. MX2 If Motor poles setting for RPM (inverter parameter P049) is set to zero, the Unit depends on the inverter mode (d060): d060 = 2 (High Frequency mode): Unit is [0.1 Hz] d060 != 2 (High Frequency mode): Unit is [0.01 Hz] RX If Motor poles setting for RPM (inverter parameter P049) is set to zero, the Unit is [0.01 Hz].

B-2 Extended Speed Control IO (21/71)

Assembly ID 21: Extended Speed Control Output

Table B-5 Extended Speed Control Output - Assembly 21 Allocation

Word	Byte	Bit Allocation							
		Bit 7	Bit 6	Bit 5	Bit 4	Bit 3	Bit 2	Bit 1	Bit 0
n	0	-	REF	CTR	-	-	RST	REV	FWD
	1	-	-	-	-	-	-	-	-
n + 1	2	Rotational Speed Reference (Low Byte)							
	3	Rotational Speed Reference (High Byte)							

Table B-6 Extended Speed Control Output - Assembly 21 Description

Name	Description
FWD	Forward run command 0: Stop 1: Forward run
REV	Reverse run command 0: Stop 1: Reverse run
RST	Fault reset Reset fault / trip condition on transition from 0 to 1
CTR	NetCtrl run command selection 0: Setting of inverter parameter A002 1: Network controlled
REF	NetRef speed reference selection 0: Setting of inverter parameter A001 1: Network controlled
Rotational Speed Reference	Reference rotational speed. Unit: [RPM]/[0.1 Hz]/[0.01 Hz]. MX2 If Motor poles setting for RPM (inverter parameter P049) is set to zero, the Unit depends on the inverter mode (d060): d060 = 2 (High Frequency mode): Unit is [0.1 Hz] d060 != 2 (High Frequency mode): Unit is [0.01 Hz] RX If Motor poles setting for RPM (inverter parameter P049) is set to zero, the Unit is [0.01 Hz].

Note For safety reasons, the FWD, REV and RST command operation requires a rising edge (0 to 1 transition) after power on and fault/trip reset.

Assembly ID 71: Extended Speed Control Input

Table B-7 Extended Speed Control Input - Assembly 71 Allocation

Word	Byte	Bit Allocation							
		Bit 7	Bit 6	Bit 5	Bit 4	Bit 3	Bit 2	Bit 1	Bit 0
n	0	ARF	RFN	CFN	RDY	DRR	DFR	WR	FLT
	1	Drive status							
n + 1	2	Rotational Speed Monitor (Low Byte)							
	3	Rotational Speed Monitor (High Byte)							

Table B-8 Extended Speed Control Input - Assembly 71 Description

Name	Description
FLT	Fault 0: Normal 1: Fault/trip
WR	Warning 0: Normal 1: Warning

Table B-8 Extended Speed Control Input - Assembly 71 Description (continued)

Name	Description
DFR	During forward run 0: Stop/reverse 1: During forward run
DRR	During reverse run 0: Stop/forward 1: During reverse run
RDY	Inverter ready status 0: Inverter not ready 1: Inverter ready
CFN	Ctrl from net: run command input selection 0: Local 1: CompoNet reference
RFN	Ref from net: speed reference input selection 0: Local 1: CompoNet reference
ARF	At reference 0: Acceleration or deceleration phase 1: At reference
Drive Status	Drive Status 1: Startup 2: Not ready 3: Ready 4: Enabled 5: Stopping 6: Fault / trip stop 7: Faulted / tripped
Rotational Speed Monitor	Actual rotational speed monitor. Unit: [RPM]/[0.1 Hz]/[0.01 Hz]. <div style="border: 1px solid gray; padding: 2px; display: inline-block; margin-bottom: 5px;">MX2</div> If Motor poles setting for RPM (inverter parameter P049) is set to zero, the Unit depends on the inverter mode (d060): d060 = 2 (High Frequency mode): Unit is [0.1 Hz] d060 != 2 (High Frequency mode): Unit is [0.01 Hz] <div style="border: 1px solid gray; padding: 2px; display: inline-block; margin-bottom: 5px;">RX</div> If Motor poles setting for RPM (inverter parameter P049) is set to zero, the Unit is [0.01 Hz].

B-3 Extended Speed and Torque Control IO (123/173)

**Assembly ID 123:
Extended Speed and
Torque Control Output**

Table B-9 Extended Speed and Torque Control Output - Assembly 123 Allocation

Word	Byte	Bit Allocation							
		Bit 7	Bit 6	Bit 5	Bit 4	Bit 3	Bit 2	Bit 1	Bit 0
n	0	-	REF	CTR	-	-	RST	REV	FWD
	1	-	-	-	-	-	-	-	-
n + 1	2	Rotational Speed Reference (Low Byte)							
	3	Rotational Speed Reference (High Byte)							
n + 2	4	Torque Reference (Low Byte)							
	5	Torque Reference (High Byte)							

Table B-10 Extended Speed and Torque Control Output - Assembly 123 Description

Name	Description
FWD	Forward run command 0: Stop 1: Forward run
REV	Reverse run command 0: Stop 1: Reverse run
RST	Fault reset Reset fault / trip condition on transition from 0 to 1
CTR	NetCtrl run command selection 0: Setting of inverter parameter A002 1: Network controlled
REF	NetRef speed reference selection 0: Setting of inverter parameter A001 1: Network controlled
Rotational Speed Reference	Reference rotational speed. Unit: [RPM]/[0.1 Hz]/[0.01 Hz]. MX2 If Motor poles setting for RPM (inverter parameter P049) is set to zero, the Unit depends on the inverter mode (d060): d060 = 2 (High Frequency mode): Unit is [0.1 Hz] d060 != 2 (High Frequency mode): Unit is [0.01 Hz] RX If Motor poles setting for RPM (inverter parameter P049) is set to zero, the Unit is [0.01 Hz].
Torque Reference	Reference torque. Unit: [%]

Note For safety reasons, the FWD, REV and RST command operation requires a rising edge (0 to 1 transition) after power on and fault/trip reset.

**Assembly ID 173:
Extended Speed and
Torque Control Input**

Table B-11 Extended Speed and Torque Control Input - Assembly 173 Allocation

Word	Byte	Bit Allocation							
		Bit 7	Bit 6	Bit 5	Bit 4	Bit 3	Bit 2	Bit 1	Bit 0
n	0	ARF	RFN	CFN	RDY	DRR	DFR	WR	FLT
	1	Drive status							
n + 1	2	Rotational Speed Monitor (Low Byte)							
	3	Rotational Speed Monitor (High Byte)							
n + 2	4	Torque Actual (Low Byte)							
	5	Torque Actual (High Byte)							

Table B-12 Extended Speed and Torque Control Input - Assembly 173 Description

Name	Description
FLT	Fault 0: Normal 1: Fault/trip
WR	Warning 0: Normal 1: Warning
DFR	During forward run 0: Stop/reverse 1: During forward run
DRR	During reverse run 0: Stop/forward 1: During reverse run
RDY	Inverter ready status 0: Inverter not ready 1: Inverter ready
CFN	Ctrl from net: run command input selection 0: Local 1: CompoNet reference
RFN	Ref from net: speed reference input selection 0: Local 1: CompoNet reference
ARF	At reference 0: Acceleration or deceleration phase 1: At reference
Drive Status	Drive Status 1: Startup 2: Not ready 3: Ready 4: Enabled 5: Stopping 6: Fault / trip stop 7: Faulted / tripped
Rotational Speed Monitor	Actual rotational speed monitor. Unit: [RPM]/[0.1 Hz]/[0.01 Hz]. MX2 If Motor poles setting for RPM (inverter parameter P049) is set to zero, the Unit depends on the inverter mode (d060): d060 = 2 (High Frequency mode): Unit is [0.1 Hz] d060 != 2 (High Frequency mode): Unit is [0.01 Hz] RX If Motor poles setting for RPM (inverter parameter P049) is set to zero, the Unit is [0.01 Hz].
Torque Actual	Actual torque monitor. Unit: [%]

B-4 Special IO (100/150)

Assembly ID 100: Special Output

Table B-13 Special Output - Assembly 100 Allocation

Word	Byte	Bit Allocation							
		Bit 7	Bit 6	Bit 5	Bit 4	Bit 3	Bit 2	Bit 1	Bit 0
n	0	Function Code							
	1	-							
n + 1	2	Register Number (Low Byte)							
	3	Register Number (High Byte)							
n + 2	4	Register Data Word 0 (Low Byte)							
	5	Register Data Word 0 (High Byte)							
n + 3	6	Register Data Word 1 (Low Byte)							
	7	Register Data Word 1 (High Byte)							

Table B-14 Special Output - Assembly 100 Description

Name	Description
Function Code	Special IO function code (in Hex): 03 Read single word 10 Write single word 43 Read double word 50 Write double word Note these codes are not the same as the explicit message service code.
Register Number	The modbus register number corresponding to a specific inverter parameter to be written.
Register Data Word 0 / 1	The data to write to the specified register. Word 0 is the least significant word. Word 1 is the most significant word (zero in case of single word write).

Assembly ID 150: Special Input

Table B-15 Special Input - Assembly 150 Allocation

Word	Byte	Bit Allocation							
		Bit 7	Bit 6	Bit 5	Bit 4	Bit 3	Bit 2	Bit 1	Bit 0
n	0	Function Code							
	1	-							
n + 1	2	Register Number (Low Byte)							
	3	Register Number (High Byte)							
n + 2	4	Register Data Word 0 (Low Byte)							
	5	Register Data Word 0 (High Byte)							
n + 3	6	Register Data Word 1 (Low Byte)							
	7	Register Data Word 1 (High Byte)							

Table B-16 Special Input - Assembly 150 Description

Word	Byte	Write success	Read success	Failure
n	0	0x10 / 0x50	0x03 / 0x43	Function code OR'ed with 0x80
	1	-	-	-
n + 1	2	Register Number (Low Byte)		
	3	Register Number (High Byte)		
n + 2	4	-	Register Data Word 0 (Low Byte)	Fault code
	5	-	Register Data Word 0 (High Byte)	-

Table B-16 Special Input - Assembly 150 Description

Word	Byte	Write success	Read success	Failure
n + 3	6	-	Register Data Word 1 (Low Byte)	-
	7	-	Register Data Word 1 (High Byte)	-

The error codes for the Special IO operation are listed here below.

Table B-17 Special Input - Assembly 150 Errors

Fault code	Name	Description
01 Hex	Function code error	A code other than 03 / 10 / 43 or 50 Hex has been set as function code.
02 Hex	Register number error	The specified register number does not exist.
04 Hex	Slave device failure	Option inverter communication failure
21 Hex	Data setting error	An upper or lower limit for the write data setting range was exceeded
22 Hex	Writing mode error	The inverter is in the wrong mode
23 Hex	Register size error.	Used 2 bytes read/write on 4 bytes register or 4 bytes read/write on 2 bytes register

B-5 Extended Control IO (101/151/153)

Assembly ID 101:
Extended Control Output

Table B-18 Extended Control Output - Assembly 101 Allocation

Word	Byte	Bit Allocation							
		Bit 7	Bit 6	Bit 5	Bit 4	Bit 3	Bit 2	Bit 1	Bit 0
n	0	CI8	CI7	CI6	CI5	CI4	CI3	REV	FWD
	1	CO2	CO1	CR	CO5	CO4	CO3	RST	FFL
n + 1	2	Rotational Speed Reference (Low Byte)							
	3	Rotational Speed Reference (High Byte)							
n + 2	4	Torque Reference (Low Byte)							
	5	Torque Reference (High Byte)							
n + 3	6	Torque Compensation Bias (Low Byte)							
	7	Torque Compensation Bias (High Byte)							

Table B-19 Extended Control Output - Assembly 101 Description

Name	Description
FWD	Forward run command 0: Stop 1: Forward run
REV	Reverse run command 0: Stop 1: Reverse run
CI3 - CI7	Control / override for multi function input terminal [3] to [7] 0: Reset 1: Override input
RX CI8	Control / override for multi function input terminal [8] 0: Reset 1: Set override for Multi Function input 8
FFL	Force external fault/trip Set external fault / trip state on transition from 0 to 1
RST	Fault reset Reset fault / trip condition on transition from 0 to 1
C01- C02	Set output 0: Reset 1: Set multi function output [1] to [2]
RX C03-C05	Set output 0: Reset 1: Set multi function output [3] to [5]
CR	Set relay output 0: Reset 1: Set relay output CR
Reference Rotational Speed	Reference rotational speed. Unit: [RPM]/[0.1 Hz]/[0.01 Hz]. MX2 If Motor poles setting for RPM (inverter parameter P049) is set to zero, the Unit depends on the inverter mode (d060): d060 = 2 (High Frequency mode): Unit is [0.1 Hz] d060 != 2 (High Frequency mode): Unit is [0.01 Hz] RX If Motor poles setting for RPM (inverter parameter P049) is set to zero, the Unit is [0.01 Hz].
Reference Torque	Reference torque. Unit [%]
Torque Compensation Bias	Compensation bias torque. Unit: [%]

Note For safety reasons, the FWD, REV and RST command operation requires a rising edge (0 to 1 transition) after power on and fault/trip reset.

Assembly ID 151:
Extended Control Input

Table B-20 Extended Control Input - Assembly 151 Allocation

Word	Byte	Bit Allocation							
		Bit 7	Bit 6	Bit 5	Bit 4	Bit 3	Bit 2	Bit 1	Bit 0
n	0	FLT	WR	RDY	ARF	-	DRR	DZS	DFR
	1	MO4	MO3	MO2	MO1	MR	CFN	-	-
n + 1	2	Rotational Speed Monitor (Low Byte)							
	3	Rotational Speed Monitor (High Byte)							
n + 2	4	Torque Actual (Low Byte)							
	5	Torque Actual (High Byte)							
n + 3	6	Output Current Monitor (Low Byte)							
	7	Output Current Monitor (High Byte)							

Table B-21 Extended Control Input - Assembly 151 Description

Name	Description
DFR	During forward run 0: Stop/reverse 1: During forward run
DZS	During zero speed 0: Non-zero speed 1: During zero speed
DRR	During reverse run 0: Stop/forward 1: During reverse run
ARF	At reference 0: Acceleration or deceleration phase 1: At reference
RDY	Inverter ready status 0: Inverter not ready 1: Inverter ready
WR	Warning 0: Normal 1: Warning
FLT	Fault 0: Normal 1: Fault/trip
CFN	Ctrl from net: run command input selection 0: Local 1: CompoNet reference
MO1 - MO2	Monitor outputs [1] to [2] 0: OFF 1: ON
RX MO3 - MO4	Monitor outputs [3] to [4] 0: OFF 1: ON
MR	Monitor relay outputs 0: OFF 1: ON
Rotational Speed Monitor	Actual rotational speed monitor. Unit: [RPM]/[0.1 Hz]/[0.01 Hz]. MX2 If Motor poles setting for RPM (inverter parameter P049) is set to zero, the Unit depends on the inverter mode (d060): d060 = 2 (High Frequency mode): Unit is [0.1 Hz] d060 != 2 (High Frequency mode): Unit is [0.01 Hz] RX If Motor poles setting for RPM (inverter parameter P049) is set to zero, the Unit is [0.01 Hz].
Torque Actual	Actual torque monitor. Unit: [%]
Output current monitor	Output current monitor. Unit: [0.1 A]

Assembly ID 153:
Extended Control + Multi
Function Input

Table B-22 Extended Control + Multi Function Input - Assembly 153 Allocation

Word	Byte	Bit Allocation							
		Bit 7	Bit 6	Bit 5	Bit 4	Bit 3	Bit 2	Bit 1	Bit 0
n	0	FLT	WR	RDY	ARF	-	DRR	DZS	DFR
	1	MO4	MO3	MO2	MO1	MR	CFN	-	-
n + 1	2	Rotational Speed Monitor (Low Byte)							
	3	Rotational Speed Monitor (High Byte)							
n + 2	4	Torque Actual (Low Byte)							
	5	Torque Actual (High Byte)							
n + 3	6	Output Current Monitor (Low Byte)							
	7	Output Current Monitor (High Byte)							
n + 4	8	MI8	MI7	MI6	MI5	MI4	MI3	MI2	MI1
	9	-	-	-	-	-	-	-	-

Table B-23 Extended Control + Multi Function Input - Assembly 153 Description

Name	Description
DFR	During forward run 0: Stop/reverse 1: During forward run
DZS	During zero speed 0: Non-zero speed 1: During zero speed
DRR	During reverse run 0: Stop/forward 1: During reverse run
ARF	At reference 0: Acceleration or deceleration phase 1: At reference
RDY	Inverter ready status 0: Inverter not ready 1: Inverter ready
WR	Warning 0: Normal 1: Warning
FLT	Fault 0: Normal 1: Fault/trip
CFN	Ctrl from net: run command input selection 0: Local 1: CompoNet reference
MO1 - MO2	Monitor outputs [1] to [2] 0: OFF 1: ON
RX MO3 - MO4	Monitor outputs [3] to [4] 0: OFF 1: ON
MR	Monitor relay outputs 0: OFF 1: ON
Rotational Speed Monitor	Actual rotational speed monitor. Unit: [RPM]/[0.1 Hz]/[0.01 Hz]. MX2 If Motor poles setting for RPM (inverter parameter P049) is set to zero, the Unit depends on the inverter mode (d060): d060 = 2 (High Frequency mode): Unit is [0.1 Hz] d060 != 2 (High Frequency mode): Unit is [0.01 Hz] RX If Motor poles setting for RPM (inverter parameter P049) is set to zero, the Unit is [0.01 Hz].
Torque Actual	Actual torque monitor. Unit: [%]

Table B-23 Extended Control + Multi Function Input - Assembly 153 Description

Name	Description
Output current monitor	Output current monitor. Unit: [0.1 A]
MI1 to MI7	Monitor multi function inputs [1] to [7] 0: OFF 1: ON
RX MI8	Monitor multi function input [8] 0: OFF 1: ON

B-6 Extended Speed and Acceleration Control IO (110/111)

Assembly ID 110:
Extended Speed and
Acceleration Control
Output

Table B-24 Extended Speed and Acceleration Control Output - Assembly 110 Allocation

Word	Byte	Bit Allocation							
		Bit 7	Bit 6	Bit 5	Bit 4	Bit 3	Bit 2	Bit 1	Bit 0
n	0	-	REF	CTR	-	FRS	RST	REV	FWD
	1	-	-	-	-	-	-	-	-
n + 1	2	Rotational Speed Reference (Low Byte)							
	3	Rotational Speed Reference (High Byte)							
n + 2	4	Acceleration Time (Low Byte)							
	5	Acceleration Time (High Byte)							
n + 3	6	Deceleration Time (Low Byte)							
	7	Deceleration Time (High Byte)							

Table B-25 Extended Speed and Acceleration Control Output - Assembly 110 Description

Name	Description
FWD	Forward run command 0: Stop 1: Forward run
REV	Reverse run command 0: Stop 1: Reverse run
RST	Fault reset Reset fault / trip condition on transition from 0 to 1
FRS	Activate Free run stop (coasting) 0: No action 1: Free run stop
CTR	NetCtrl run command selection 0: Setting of inverter parameter A002 1: Network controlled
REF	NetRef speed and acceleration/deceleration reference selection 0: Setting of inverter parameters A001, F002 and F003 1: Network controlled
Rotational Speed Reference	Reference rotational speed. Unit: [RPM]/[0.1 Hz]/[0.01 Hz]. MX2 If Motor poles setting for RPM (inverter parameter P049) is set to zero, the Unit depends on the inverter mode (d060): d060 = 2 (High Frequency mode): Unit is [0.1 Hz] d060 != 2 (High Frequency mode): Unit is [0.01 Hz] RX If Motor poles setting for RPM (inverter parameter P049) is set to zero, the Unit is [0.01 Hz].

Table B-25 *Extended Speed and Acceleration Control Output - Assembly 110 Description (continued)*

Name	Description
Acceleration time	Reference acceleration time. Unit: [0.1 s] Range of setting [0.1 to 3600.0] Be sure to set the REF bit to control the acceleration or deceleration time using this assembly. Otherwise the F002 and F003 will be used independent of parameter A001.
Deceleration time	Reference deceleration time. Unit: [0.1 s] Range of setting [0.1 to 3600.0] Be sure to set the REF bit to control the acceleration or deceleration time using this assembly. Otherwise the F002 and F003 will be used independent of parameter A001.

Note For safety reasons, the FWD, REV and RST command operation requires a rising edge (0 to 1 transition) after power on and fault/trip reset.

**Assembly ID 111:
Extended Speed and
Acceleration Control Input**

Table B-26 *Extended Speed and Acceleration Control Input - Assembly 111 Allocation*

Word	Byte	Bit Allocation							
		Bit 7	Bit 6	Bit 5	Bit 4	Bit 3	Bit 2	Bit 1	Bit 0
n	0	MI3	MI2	MI1	ARF	-	FLT	DRR	DFR
	1	Drive Status Detail							
n + 1	2	Rotational Speed Monitor (Low Byte)							
	3	Rotational Speed Monitor (High Byte)							
n + 2	4	Output Current Monitor (Low Byte)							
	5	Output Current Monitor (High Byte)							
n + 3	6	Trip Cause							
	7	RFN	CFN	FWT	MI8	MI7	MI6	MI5	MI4

Table B-27 *Extended Speed and Acceleration Control Input - Assembly 111 Description*

Name	Description
DFR	During forward run 0: Stop/reverse 1: During forward run
DRR	During reverse run 0: Stop/forward 1: During reverse run
FLT	Fault 0: Normal 1: Fault/trip
ARF	At reference 0: Acceleration or deceleration phase 1: At reference
MI1 to MI7	Monitor multi function inputs [1] to [7] 0: OFF 1: ON
RX MI8	Monitor multi function inputs [8] 0: OFF 1: ON
CFN	Ctrl from net: run command input selection 0: Local 1: CompoNet reference

Table B-27 Extended Speed and Acceleration Control Input - Assembly 111
Description (continued)

Name	Description
RFN	Ref from net: speed reference input selection 0: Local 1: CompoNet reference
RX	FWT Forward Terminal state 0: OFF 1: ON
Drive Status Detail	Drive Status Detail 0: Stopping 1: Running 2: Jogging 3: Free running (coasting) 4: Direct current DC braking 5: Pickup (Decelerated stop) 7: During pickup (Retry) 8: Waiting (Retry) 10: Trip condition 11: Under-voltage condition
Rotational Speed Monitor	Actual rotational speed monitor. Unit: [RPM]/[0.1 Hz]/[0.01 Hz]. MX2 If Motor poles setting for RPM (inverter parameter P049) is set to zero, the Unit depends on the inverter mode (d060): d060 = 2 (High Frequency mode): Unit is [0.1 Hz] d060 != 2 (High Frequency mode): Unit is [0.01 Hz] RX If Motor poles setting for RPM (inverter parameter P049) is set to zero, the Unit is [0.01 Hz].
Output current monitor	Output current monitor. Unit: [0.1 A]
Trip Cause	Returns direct trip cause. Value 1 to 99 decimal correspond to trip E01 to E99.

APPENDIX C

General Object Specification

C-1 Identity Object (Class 0x01)

Supported Service Codes Table C-1 Identity Object - Supported Service Codes

Service Code No. (hex)	Service
0E	Get attribute single
05	Reset (return to initial status)

Object Details

Table C-2 Identity Object - Object Details

Instance (hex)	Attribute (hex)	Name	Content	Setting range	Default	Get	Set	Size
01	01	Vendor ID	Indicates the manufacturer's ID	----	47 (OMRON Corporation)	Yes	No	UINT
	02	Device Type	Indicates the CompoNet profile classification	----	2 (AC Drive)	Yes	No	UINT
	03	Product Code	Product code depending on the inverter model. See note.	----	Depending on inverter	Yes	No	UINT
	04	Revision	Indicates overall software revision for CompoNet Option Board and Inverter Note this attribute depends on both the Option Board and the Inverter. Be sure to match the correct EDS file to this revision for configuration.	----	Depending on unit	Yes	No	WORD
	05	Status	Indicates communications status for CompoNet Option Board Bit allocation: 0: Always ON 8: Minor Recoverable Fault 9: Minor Unrecoverable Fault 10: Major Recoverable Fault 11: Major Unrecoverable Fault	----	0 Hex	Yes	No	UINT
	06	Serial Number	Indicates the serial number of the CompoNet Option Board	----	Unique for each unit	Yes	No	LONG
	07	Product Name	Product name depending on the Inverter model. See note.	----	Depending on inverter	Yes	No	UINT
	09	Configuration Consistency Value	Indicates the consistency value which is incremented if an inverter parameter is changed and stored to EEPROM through the Option Board interface. Please note changes using the other Inverter interfaces (Serial, Digital operator) will not influence this attribute. Writing to EEPROM save (Modbus address 0900 Hex, class 64 Hex, instance 09 Hex, attribute 0 Hex) will also increment this value.	----	0 Hex	Yes	No	UINT
	65	Firmware Revision Option Board	Indicates software version of the CompoNet Option Board.	----	Depending on unit	Yes	No	WORD

Note The product code and the product name depend on the model of Inverter being used, as shown in the following two tables for MX2 Inverters and RX Inverters.

MX2 Table C-3 Model List MX2

MX2 Model Name	Product Name	Product Code (Dec)	EDS File
MX2-AB001-E, MX2-A2001-E	3G3AX-MX2-CRT-AB001_A2001-E	1800	3G3AX-MX2-CRT-AB001_A2001-E.eds
MX2-AB002-E, MX2-A2002-E	3G3AX-MX2-CRT-AB002_A2002-E	1801	3G3AX-MX2-CRT-AB002_A2002-E.eds
MX2-AB004-E, MX2-A2004-E	3G3AX-MX2-CRT-AB004_A2004-E	1802	3G3AX-MX2-CRT-AB004_A2004-E.eds
MX2-AB007-E, MX2-A2007-E	3G3AX-MX2-CRT-AB007_A2007-E	1804	3G3AX-MX2-CRT-AB007_A2007-E.eds
MX2-AB015-E, MX2-A2015-E	3G3AX-MX2-CRT-AB015_A2015-E	1806	3G3AX-MX2-CRT-AB015_A2015-E.eds
MX2-AB022-E, MX2-A2022-E	3G3AX-MX2-CRT-AB022_A2022-E	1807	3G3AX-MX2-CRT-AB022_A2022-E.eds
MX2-A2037-E	3G3AX-MX2-CRT-A2037-E	1809	3G3AX-MX2-CRT-A2037-E.eds
MX2-A2055-E	3G3AX-MX2-CRT-A2055-E	1811	3G3AX-MX2-CRT-A2055-E.eds
MX2-A2075-E	3G3AX-MX2-CRT-A2075-E	1812	3G3AX-MX2-CRT-A2075-E.eds
MX2-A2110-E	3G3AX-MX2-CRT-A2110-E	1813	3G3AX-MX2-CRT-A2110-E.eds
MX2-A2150-E	3G3AX-MX2-CRT-A2150-E	1814	3G3AX-MX2-CRT-A2150-E.eds
MX2-A4004-E	3G3AX-MX2-CRT-A4004-E	1822	3G3AX-MX2-CRT-A4004-E.eds
MX2-A4007-E	3G3AX-MX2-CRT-A4007-E	1824	3G3AX-MX2-CRT-A4007-E.eds
MX2-A4015-E	3G3AX-MX2-CRT-A4015-E	1826	3G3AX-MX2-CRT-A4015-E.eds
MX2-A4022-E	3G3AX-MX2-CRT-A4022-E	1827	3G3AX-MX2-CRT-A4022-E.eds
MX2-A4030-E	3G3AX-MX2-CRT-A4030-E	1828	3G3AX-MX2-CRT-A4030-E.eds
MX2-A4040-E	3G3AX-MX2-CRT-A4040-E	1830	3G3AX-MX2-CRT-A4040-E.eds
MX2-A4055-E	3G3AX-MX2-CRT-A4055-E	1831	3G3AX-MX2-CRT-A4055-E.eds
MX2-A4075-E	3G3AX-MX2-CRT-A4075-E	1832	3G3AX-MX2-CRT-A4075-E.eds
MX2-A4110-E	3G3AX-MX2-CRT-A4110-E	1833	3G3AX-MX2-CRT-A4110-E.eds
MX2-A4150-E	3G3AX-MX2-CRT-A4150-E	1834	3G3AX-MX2-CRT-A4150-E.eds

RX Table C-4 Model List RX

RX Model Name	Product Name	Product Code (Dec)	EDS File
RX-A2004-E	3G3AX-RX-CRT-A2004-E	2041	3G3AX-RX-CRT-A2004-E.eds
RX-A2007-E	3G3AX-RX-CRT-A2007-E	2042	3G3AX-RX-CRT-A2007-E.eds
RX-A2015-E	3G3AX-RX-CRT-A2015-E	2043	3G3AX-RX-CRT-A2015-E.eds
RX-A2022-E	3G3AX-RX-CRT-A2022-E	2044	3G3AX-RX-CRT-A2022-E.eds
RX-A2037-E	3G3AX-RX-CRT-A2037-E	2045	3G3AX-RX-CRT-A2037-E.eds
RX-A2055-E	3G3AX-RX-CRT-A2055-E	2046	3G3AX-RX-CRT-A2055-E.eds
RX-A2075-E	3G3AX-RX-CRT-A2075-E	2047	3G3AX-RX-CRT-A2075-E.eds
RX-A2110-E	3G3AX-RX-CRT-A2110-E	2048	3G3AX-RX-CRT-A2110-E.eds
RX-A2150-E	3G3AX-RX-CRT-A2150-E	2049	3G3AX-RX-CRT-A2150-E.eds
RX-A2185-E	3G3AX-RX-CRT-A2185-E	2050	3G3AX-RX-CRT-A2185-E.eds
RX-A2220-E	3G3AX-RX-CRT-A2220-E	2051	3G3AX-RX-CRT-A2220-E.eds
RX-A2300-E	3G3AX-RX-CRT-A2300-E	2052	3G3AX-RX-CRT-A2300-E.eds
RX-A2370-E	3G3AX-RX-CRT-A2370-E	2053	3G3AX-RX-CRT-A2370-E.eds
RX-A2450-E	3G3AX-RX-CRT-A2450-E	2054	3G3AX-RX-CRT-A2450-E.eds
RX-A2550-E	3G3AX-RX-CRT-A2550-E	2055	3G3AX-RX-CRT-A2550-E.eds
RX-A4004-E	3G3AX-RX-CRT-A4004-E	2068	3G3AX-RX-CRT-A4004-E.eds
RX-A4007-E	3G3AX-RX-CRT-A4007-E	2069	3G3AX-RX-CRT-A4007-E.eds
RX-A4015-E	3G3AX-RX-CRT-A4015-E	2070	3G3AX-RX-CRT-A4015-E.eds
RX-A4022-E	3G3AX-RX-CRT-A4022-E	2071	3G3AX-RX-CRT-A4022-E.eds
RX-A4040-E	3G3AX-RX-CRT-A4040-E	2072	3G3AX-RX-CRT-A4040-E.eds

Table C-4 Model List RX

RX

RX Model Name	Product Name	Product Code (Dec)	EDS File
RX-A4055-E	3G3AX-RX-CRT-A4055-E	2073	3G3AX-RX-CRT-A4055-E.eds
RX-A4075-E	3G3AX-RX-CRT-A4075-E	2074	3G3AX-RX-CRT-A4075-E.eds
RX-A4110-E	3G3AX-RX-CRT-A4110-E	2075	3G3AX-RX-CRT-A4110-E.eds
RX-A4150-E	3G3AX-RX-CRT-A4150-E	2076	3G3AX-RX-CRT-A4150-E.eds
RX-A4185-E	3G3AX-RX-CRT-A4185-E	2077	3G3AX-RX-CRT-A4185-E.eds
RX-A4220-E	3G3AX-RX-CRT-A4220-E	2078	3G3AX-RX-CRT-A4220-E.eds
RX-A4300-E	3G3AX-RX-CRT-A4300-E	2079	3G3AX-RX-CRT-A4300-E.eds
RX-A4370-E	3G3AX-RX-CRT-A4370-E	2080	3G3AX-RX-CRT-A4370-E.eds
RX-A4450-E	3G3AX-RX-CRT-A4450-E	2081	3G3AX-RX-CRT-A4450-E.eds
RX-A4550-E	3G3AX-RX-CRT-A4550-E	2082	3G3AX-RX-CRT-A4550-E.eds
RX-B4750-E	3G3AX-RX-CRT-B4750-E	2083	3G3AX-RX-CRT-B4750-E.eds
RX-B4900-E	3G3AX-RX-CRT-B4900-E	2084	3G3AX-RX-CRT-B4900-E.eds
RX-B411K-E	3G3AX-RX-CRT-B411K-E	2085	3G3AX-RX-CRT-B411K-E.eds
RX-B413K-E	3G3AX-RX-CRT-B413K-E	2086	3G3AX-RX-CRT-B413K-E.eds

C-2 Message Router Object (Class 0x02)

Object Details

No vendor specific attributes are supported.

C-3 Assembly Object (Class 0x04)

Supported Service Codes *Table C-5 Assembly Object - Supported Service Codes*

Service Code No. (hex)	Service
0E	Get attribute single
10	Set attribute single

Object Details

Table C-6 Assembly Object - Object Details

Instance (hex)	Attribute (hex)	Name	Content	Setting range	Default	Get	Set	Size
14	03	Remote I/O Data	Data same as Basic Speed IO (Output)	----	00 00 00 00	Yes	Yes	BYTE x 4
15	03	Remote I/O Data	Data same as Extended Speed IO (Output)	----	00 00 00 00	Yes	Yes	BYTE x 4
46	03	Remote I/O Data	Data same as Basic Speed IO (Input)	----	00 00 00 00	Yes	No	BYTE x 4
47	03	Remote I/O Data	Data same as Extended Speed IO (Input)	----	00 00 00 00	Yes	No	BYTE x 4
64	03	Remote I/O Data	Data same as Special IO (Output)	----	00 00 00 00 00 00 00 00	Yes	Yes	BYTE x 8
65	03	Remote I/O Data	Data same as Extended Control IO (Output)	----	00 00 00 00 00 00 00 00	Yes	Yes	BYTE x 8
6E	03	Remote I/O Data	Data same as Extended Speed and Acceleration Control (Output)	----	00 00 00 00 00 00 00 00	Yes	Yes	BYTE x 8
6F	03	Remote I/O Data	Data same as Extended Speed and Acceleration Control (Input)	----	00 00 00 00 00 00 00 00	Yes	No	BYTE x 8
7B	03	Remote I/O Data	Data same as Extended Speed and Torque Control (Output)	----	00 00 00 00 00 00	Yes	Yes	BYTE x 6
8B	03	Remote I/O Data	Flexible IO (Output)	----	00 00 00 00 00 00 00 00 00 00 00 00 00 00 00 00 00 00 00 00	Yes	Yes	BYTE x 16 max (see note 2)
96	03	Remote I/O Data	Data same as Special IO (Input)	----	00 00 00 00 00 00 00 00	Yes	No	BYTE x 8
97	03	Remote I/O Data	Data same as Extended Control IO (Input)	----	00 00 00 00 00 00 00 00	Yes	No	BYTE x 8
99	03	Remote I/O Data	Data same as Extended Control IO and Multi-Function monitor (Input)	----	00 00 00 00 00 00 00 00 00 00	Yes	No	BYTE x 10
9F	03	Remote I/O Data	Flexible IO (Input)	----	00 00 00 00 00 00 00 00 00 00 00 00 00 00 00 00 00 00 00 00	Yes	No	BYTE x 16 max (see note 2)

Note 1 The data allocation of the assembly in this objects are the same as defined in Appendix B.

Note 2 The size of the Flexible IO assemblies are depending on the actual configuration.

C-4 Connection Object (Class 0x05)

Supported Service Codes

Table C-7 Connection Object - Supported Service Codes

Service Code No. (hex)	Service
0E	Get attribute single
10	Set attribute single

Object Details

Table C-8 Connection Object - Object Details

Instance (hex)	Attribute (hex)	Name	Content	Setting range	Default	Get	Set	Size
01 Multicast Poll I/O	01	State	Status of the instance	----	1	Yes	No	USINT
	02	Instance type	Type of the instance	----	1	Yes	No	USINT
	03	TransportClass_Trigger	Defines behaviour of the connection	----	83 Hex	Yes	No	BYTE
	07	Produced connection size	Indicates the maximum number of bytes for transmission.	----	16	Yes	No	UINT
	08	Consumed connection size	Indicates the maximum number of bytes for reception.	----	16	Yes	No	UINT
	09	Expected packet rate	Indicates the length of the internal processing timeout when a communication request is received (incremented by 10 ms units)	0 - 65535	0	Yes	Yes	UINT
	0C	Watchdog timeout action	Indicates the action for internal processing timeout related to communications. 00: Retain timeout status (until reset or cleared) 01: Cut connection automatically 02: Operate again with same connection as is	----	0	Yes	Yes	USINT
	0D	Produced connection path length	Number of bytes for produced connection path. No data for explicit messages	----	3	Yes	No	UINT
	0E	Produced connection path	Specifies the application object for produced connection path. No data for explicit messages	----	Depending on Default Connection Path	Yes	Yes	ARRAY
	0F	Consumed connection path length	Number of bytes for consumed connection path. No data for explicit messages	----	3	Yes	No	UINT
10	Consumed connection path	Specifies the application object for consumed connection path. No data for explicit messages	----	Depending on Default Connection Path	Yes	Yes	ARRAY	

C-5 Discrete Input Point Object (Class 0x08)

Supported Service Codes

Table C-9 Discrete Input Point Object - Supported Service Codes

Service Code No. (hex)	Service
0E	Get attribute single
10	Set attribute single

Object Details

Table C-10 Discrete Input Point Object - Object Details

Instance (hex)	Attribute (hex)	Name	Content	Setting range	Default	Get	Set	Size
01 to 09 (See note)	03	Value	Read input point value 0: Off 1: On	----	----	Yes	No	BOOL
	69	Override	Override input point value 0: Off 1: On	----	----	Yes	Yes	BOOL



The instance 1 to 7 correspond to the MX2 inverter input terminal [1] to [7].



The instance 1 to 8 correspond to the RX inverter input terminal [1] to [8]. Instance 9 corresponds to the FW input terminal.

C-6 Discrete Output Point Object (Class 0x09)

Supported Service Codes

Table C-11 Discrete Output Point Object - Supported Service Codes

Service Code No. (hex)	Service
0E	Get attribute single
10	Set attribute single

Object Details

Table C-12 Discrete Output Point Object - Object Details

Instance (hex)	Attribute (hex)	Name	Content	Setting range	Default	Get	Set	Size
01 to 06 (See note)	03	Value	Control the output point value 0: Off 1: On	----	----	Yes	Yes	BOOL



The instance 1 to 3 correspond to the Inverter output terminals respectively output [11], output [12] and alarm relay contacts (AL0, AL1, AL2). See MX2 User Manual Section 4-6-3.



The instance 1 to 6 correspond to the RX inverter output terminals respectively output 1 [11] to output 5 [15] and alarm relay contacts (AL0, AL1, AL2). See RX User Manual section 4-2, "Specifications of the Relay Output Terminals".

C-7 Unit Parameter Object (Class 0x94)

Supported Service Codes

Table C-13 Unit Parameter Object - Supported Service Codes

Service Code No. (hex)	Service
0E	Get attribute single
10	Set attribute single

Object Details

Table C-14 Unit Parameter Object - Object Details

Instance (hex)	Attribute (hex)	Name	Content	Setting range	Default	Get	Set	Size
01	64	Default Connection Path	Selection of the default connection path. Actual value is read and written to inverter parameter P046. Please refer to section 3-1 <i>Installation of EDS files</i> on page 23 for details on P046.	0 - 7	1	Yes	Yes	USINT

C-8 CompoNet Link Object (Class 0xF7)

Supported Service Codes

Table C-15 CompoNet Link Object - Supported Service Code

Service Code No. (hex)	Service
0E	Get attribute single
10	Set attribute single

Object Details

Table C-16 CompoNet Link Object - Object Details

Instance (hex)	Attribute (hex)	Name	Content	Setting range	Default	Get	Set	Size
01	01	MAC ID	Node address of Option Board	0 - 63	0	Yes	No	USINT
	02	Baud rate	Baud rate of Option Board: 0: 93.75 kbit/s 1: Reserved 2: 1.5 Mbit/s 3: 3 Mbit/s 4: 4 Mbit/s	0 - 4	0	Yes	No	UINT
	05	Allocation choice	CompoNet communication connection information	----	2	Yes	No	WORD
	06	MAC ID Switch Changed	Node address changed after power-on or reset	----	0	Yes	No	BOOL
	08	MAC ID Switch Value	Node address setting actual value	----	0	Yes	No	UINT
	0A	Explicit message timer	Waiting timer setting for getting token from Master to Slave	----	0	Yes	Yes	UINT

APPENDIX D

AC Drive Object Specification

D-1 Motor Data Object (Class 0x28)

Supported Service Codes

Table D-1 Motor Data Object - Supported Service Codes

Service Code No. (hex)	Service
0E	Get attribute single
10	Set attribute single

Object Details

Table D-2 Motor Data Object - Object Details

Instance (hex)	Attribute (hex)	Name	Content	Setting range	Default	Get	Set	Size
01	03	Motor Type	<p>Depends on the motor control mode which is selected for the Inverter. The motor control mode can be read by inverter parameter d060.</p> <p>Get values: 3: PM synchronous motor (d060 = 3) 7: Squirrel cage induction motor (d060 != 3)</p> <p>Set values: 3: in case inverter control mode is not in this mode, the inverter will be set to PM synchronous mode (d060 = 3). 7: in case inverter control mode is PM synchronous mode (d060 = 3), the inverter will be set to ND mode (d060 = 1).</p> <p>See also note.  For the RX Inverter, the Motor Type is fixed to value 7.</p>	----	7	Yes	Yes	US INT
	06	Rated Current	Motor rated current. Unit: [0.1 A]	----	Depending on inverter type	Yes	Yes	UINT
	07	Rated Voltage	Motor rated voltage. Unit: [V]	----	Depending on inverter type	Yes	Yes	UINT
	08	Rated Power	Motor rated power. Unit: [W]	----	Depending on inverter type	Yes	Yes	UINT
	09	Rated Frequency	Motor rated frequency. Unit: [Hz].	300 - MaxSpeed	50	Yes	Yes	UINT
	0B	MaxSpeed	Maximum allowed motor speed. Unit: [RPM]	Depending on motor control mode	50	Yes	Yes	UINT
	0C	PoleCount	Number of poles in the motor. (speed conversion only)	0 - 38	0	Yes	Yes	UINT
			Only even number of poles are valid.					

MX2

A change of the Motor Type value will cause an inverter and an Option Board reset. This is equivalent to setting inverter parameters b171 (Inverter mode selection) and b180 (Parameter initialization trigger).

D-2 Control Supervisor Object (Class 0x29)

Supported Service Codes

Table D-3 Control Supervisor Object - Supported Service Codes

Service Code No. (hex)	Service
0E	Get attribute single
10	Set attribute single

Object Details

Table D-4 Control Supervisor Object - Object Details

Instance (hex)	Attribute (hex)	Name	Content	Setting range	Default	Get	Set	Size
01	03	Run1	Run Forward 0: Stop 1: Run Forward	----	0	Yes	Yes	BOOL
	04	Run2	Run Reverse 0: Stop 1: Run Reverse	----	0	Yes	Yes	BOOL
	05	Net Ctrl	Run command input is set 0: Setting of inverter parameter A002 1: CompoNet reference	----	0	Yes	Yes	BOOL
	06	State	Drive status: 1: Startup 2: Not ready 3: Ready 4: Enabled 5: Stopping 6: Fault / trip stop 7: Faulted / tripped	----	----	Yes	No	UINT
	07	Running1	Forward Running 0: Stop 1: Forward Running	----	----	Yes	No	BOOL
	08	Running2	Reverse Running 0: Stop 1: Reverse Running	----	----	Yes	No	BOOL
	09	Ready	Inverter ready 0: Not ready 1: Ready	----	----	Yes	No	UINT
	0A	Faulted	Inverter fault / trip 0: No inverter fault / trip 1: Inverter fault / trip	----	----	Yes	No	BOOL
	0B	Warning	Inverter warning 0: No inverter warning 1: Inverter warning	----	----	Yes	No	BOOL
	0C	Fault Rst	Reset fault / trip state of inverter when written to 1.	----	0	Yes	Yes	BOOL
	0D	Fault Code	Current fault / trip state code. See note.	----	----	Yes	No	UINT
	0F	Ctrl From Net	Run command input selection 0: Setting of A002 1: CompoNet controlled	----	----	Yes	No	BOOL
	10	Net Fault Mode	Inverter action on network error 0: Inverter fault / trip and stop (P045 = 1) 1: Ignore (P045 = 2) 2: Vendor specific.	----	2	Yes	Yes	UINT
	11	Force Fault	Force external fault / trip state for inverter on rising edge.	----	0	Yes	Yes	BOOL
	12	Force Status	Status external fault forced 0: Fault not forced 1: Fault forced	----	0	Yes	No	BOOL
	14	Net Idle Mode	Inverter action on network idle mode 0: Stop (P048 = 4) 1: Ignore (P048 = 2) 2: Vendor specific.	----	2	Yes	Yes	USINT

Table D-4 Control Supervisor Object - Object Details (continued)

Instance (hex)	Attribute (hex)	Name	Content	Setting range	Default	Get	Set	Size
01	64	Drive State Detail	Drive State Detail value: 0: Stopping 1: Running 2: Jogging 3: Free running (coasting) 4: Direct current DC braking 5: Pickup (Decelerated stop) 7: During pickup (Retry) 8: Waiting (Retry) 10: Trip condition 11: Under-voltage condition	----	----	Yes	No	USINT
	65	Trip Cause	Returns direct trip cause (E01 to E99)	----	----	Yes	No	USINT
	66	Free Run	Activate Free run stop (coasting) 0: No action 1: Free run stop	----	0	Yes	Yes	BOOL

Note The following table shows the conversion between the Inverter Error or Trip code and the CIP Fault and Warning codes.

Table D-5 Error Code Conversion

Error/Trip code		CIP Fault and Warning Code	
Code	Name	Code	Name
E01	Over-current event while at constant speed	2200	Current Inside the Device
E02	Over-current event during deceleration	2214	Overcurrent during Slowdown
E03	Over-current event during acceleration	2213	Overcurrent during Startup
E04	Over-current event during other conditions	2200	Current Inside the Device
E05	Overload protection	2220	Continuous Overcurrent
E06	Braking resistor overload protection	7112	Brake Chopper overcurrent
E07	Over-voltage protection	3210	Overvoltage inside the device
E08	EEPROM error	6320	Parameter Error
E09	Under-voltage error	3220	Undervoltage inside the Device
E10	Current detection error	5210	Measurement Circuit
E11	CPU error	6100	Internal Software
E12	External trip	9000	External Malfunction
E13	USP	9000	External Malfunction
E14	Ground fault	2120	Short to Earth
E15	Input over-voltage	3110	Mains overvoltage
E16	Momentary electricity failure protection	3120	Mains undervoltage
E20	Temperature error with cooling fan frequency lowering	4000	Temperature
E21	Inverter thermal trip	4200	Device Temperature
E22	CPU error	5000	Device Hardware
E24	Phase Failure	3130	Phase Failure
E25	Main circuit error	5410	Output Stages
E30	Driver error	5400	Power section
E35	Thermistor	7300	Sensor
E36	Braking error	9000	External Malfunction
E37	Safe Stop	9000	External Malfunction
E38	Low-speed overload protection	2221	Continuous Overcurrent no1
E40	Operator connection	5300	Operator control circuit
E41	Modbus communication error	7500	Communication

Table D-5 Error Code Conversion (continued)

Error/Trip code		CIP Fault and Warning Code		
Code	Name	Code	Name	
E43	EzSQ invalid instruction	6200	User Software	
E44	EzSQ nesting count error	6200	User Software	
E45	EzSQ instruction error	6200	User Software	
E50... 59	EzSQ user trip (0 to 9)	6200	User Software	
E51	EzSQ user trip (0 to 9)	6200	User Software	
E52	EzSQ user trip (0 to 9)	6200	User Software	
E53	EzSQ user trip (0 to 9)	6200	User Software	
E54	EzSQ user trip (0 to 9)	6200	User Software	
E55	EzSQ user trip (0 to 9)	6200	User Software	
E56	EzSQ user trip (0 to 9)	6200	User Software	
E57	EzSQ user trip (0 to 9)	6200	User Software	
E58	EzSQ user trip (0 to 9)	6200	User Software	
E59	EzSQ user trip (0 to 9)	6200	User Software	
MX2	E60	Option error (inverter communications error)	7510	Serial Interface No 1
	E61	Option error (Duplicated MAC ID)	7510	Serial Interface No 1
	E62	Option error (External trip)	7510	Serial Interface No 1
	E63	CRT/CRT Communication lost / idle	7510	Serial Interface No 1
	E64	Illegal flexible mapping	6320	Parameter error
	E65	Option error (reserved)	7510	Serial Interface No 1
	E66	Option error (reserved)	7510	Serial Interface No 1
	E67	Option error (reserved)	7510	Serial Interface No 1
	E68	Option error (reserved)	7510	Serial Interface No 1
	E69	Option error (inverter communication lost error)	7510	Serial Interface No 1
RX	E70	Option error (inverter communications error)	7510	Serial Interface No 2
	E71	Option error (Duplicated MAC ID)	7510	Serial Interface No 2
	E72	Option error (External trip)	7510	Serial Interface No 2
	E73	CRT/CRT Communication lost / idle	7510	Serial Interface No 2
	E74	Illegal flexible mapping	6320	Parameter error
	E75	Option error (reserved)	7510	Serial Interface No 2
	E76	Option error (reserved)	7510	Serial Interface No 2
	E77	Option error (reserved)	7510	Serial Interface No 2
	E78	Option error (reserved)	7510	Serial Interface No 2
	E79	Option error (inverter communication lost error)	7510	Serial Interface No 2
E80	Encoder disconnection	7305	Incremental Encoder 1 Defective	
E81	Excessive speed	8401	Velocity following error	
E82	Positioning error	8500	Position	
E83	Position control range error	8501	Position Following Error	

D-3 AC/DC Drive Object (Class 0x2A)

Supported Service Codes

Table D-6 AC/DC Drive Object - Supported Service Codes

Service Code No. (hex)	Service
0E	Get attribute single
10	Set attribute single

Object Details

Table D-7 AC/DC Drive Object - Object Details

Instance (hex)	Attribute (hex)	Name	Content	Setting range	Default	Get	Set	Size
1	03	At Reference	Status indication for at reference 0: Stopped, accelerating or decelerating 1: At reference	----	----	Yes	No	BOOL
	04	Net Ref	Speed reference selection 0: Setting of inverter parameter A002 1: Network controlled	0 - 1	0	Yes	Yes	BOOL
	06	Drive Mode	Fixed to value: 0: Vendor specific mode	0	0	Yes	Yes	USINT
	07	Speed Actual	Actual rotational speed monitor. Unit: [RPM]/[0.1 Hz]/[0.01 Hz]. MX2 If Motor poles setting for RPM (Inverter parameter P049 is set to zero, the Unit depends on the inverter mode (d060): d060 = 2 (High Frequency mode): Unit is [0.1 Hz] d060 != 2 (High Frequency mode): Unit is [0.01 Hz] RX If Motor poles setting for RPM (Inverter parameter P049) is set to zero, the Unit is [0.01 Hz].	----	----	Yes	No	INT
	08	Speed Ref	Reference rotational speed. Unit: [RPM]/[0.1 Hz]/[0.01 Hz]. MX2 If Motor poles setting for RPM (Inverter parameter P049 is set to zero, the Unit depends on the inverter mode (d060): d060 = 2 (High Frequency mode): Unit is [0.1 Hz] d060 != 2 (High Frequency mode): Unit is [0.01 Hz] RX If Motor poles setting for RPM (Inverter parameter P049) is set to zero, the Unit is [0.01 Hz].	0 - Max Speed	0	Yes	Yes	INT
	09	Current Actual	Output current monitor. Unit: [0.1 A]	----	----	Yes	No	INT
	0F	Power Actual	Output power monitor. Unit: [W]	----	----	Yes	No	INT
	11	Output Voltage	Output voltage monitor. Unit: [V]	----	----	Yes	No	INT
	12	Accel Time	Acceleration time. Unit: [ms]	10 - 3600000	10000	Yes	Yes	UINT
	13	Decel Time	Deceleration time. Unit: [ms]	10 - 3600000	10000	Yes	Yes	UINT
	1D	Ref From Net	Speed reference input selection monitor: 0: Local 1: Network reference	0 - 1	0	Yes	No	BOOL
	77	Torque Actual Rel	Actual torque monitor. Unit: [%]	----	----	Yes	Yes	INT
	78	Torque Ref Rel	Reference torque. Unit [%]	0 - 200	0	Yes	Yes	INT
	79	Torque Compensation Bias Rel	Compensation bias torque. Unit: [%]	-200 - 200	0	Yes	Yes	INT
7A	At Zero Speed	Status indication at zero speed 0: Non-zero speed 1: Zero speed	----	----	Yes	No	BOOL	

APPENDIX E

CompoNet Explicit Messages

E-1 Basic Format of Explicit Messages

The basic format of each command and response is shown below.

Command:

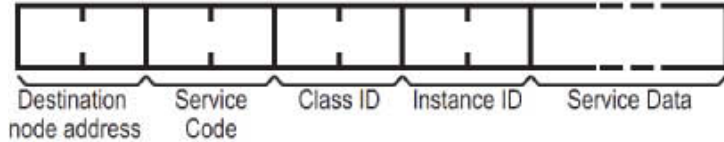

Response:

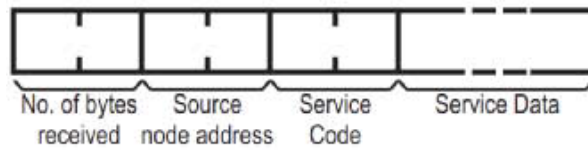

Service codes supported by the Unit are

Table E-1 Service Codes

Service	Read	Write	Reset
Command	0E Hex	10 Hex	05 Hex
Normal response	8E Hex	90 Hex	85 Hex

Destination / Source Node address indicates the Node address for the Explicit Message. For Word Mixed Units such as the 3G3AX-RX-CRT-E, the value is defined as 10@@ Hex, where @@ is the Slave Unit's node address (range 0 to 3F Hex).

Example 1: Reset the Unit

Command:

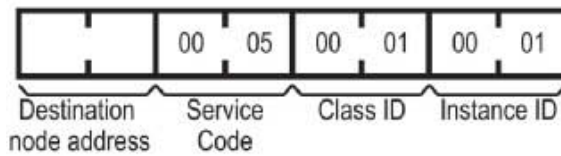

Response:

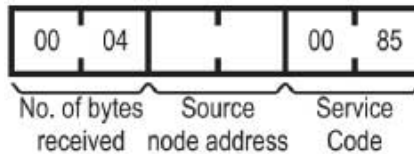

**Example 2:
Reading USINT Object
Trip Cause**

Parameter:Class 29 Hex, Instance 01 Hex, Attribute 65 Hex
Command:

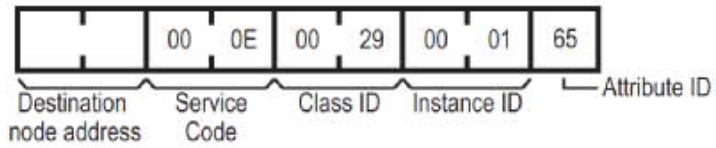

Response:

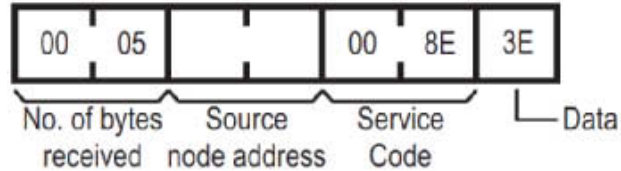

The latest trip of the inverter has been caused by E62 (value 3E Hex). This is Force fault/trip from the Option Board.

**Example 3:
Writing BOOL Object
ForceFault/Trip**

Parameter:Class 29 Hex, Instance 01 Hex, Attribute 11 Hex
Command:

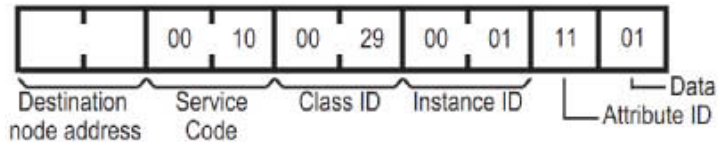

Response:

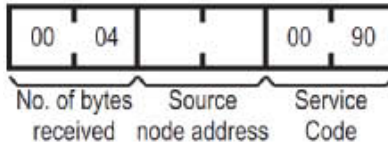

**Example 4:
Read INT SpeedActual**

Parameter:Class 2A Hex, Instance 01 Hex, Attribute 07 Hex
Command:

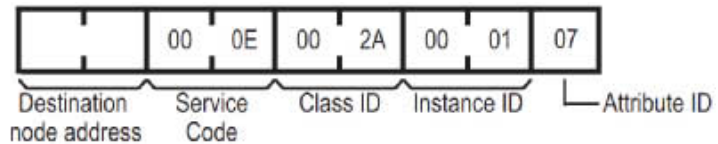

Response:

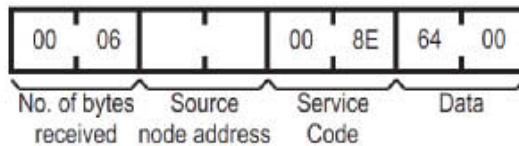

The actual speed is read as 10.0 Hz (0064 Hex). Please note the swapping of the data following CIP data type encoding.

E-2 Function Code Object (Class 0x65)

E-2-1 Supported Service Codes

Table E-2 Function Code Object (Class 0x65) Supported Service Codes

Service Code No. (hex)	Service
0E	Get attribute single
10	Set attribute single

E-2-2 Supported Instance and Attribute Codes

The inverter parameter Function code are mapped to the object's instance and attributes.

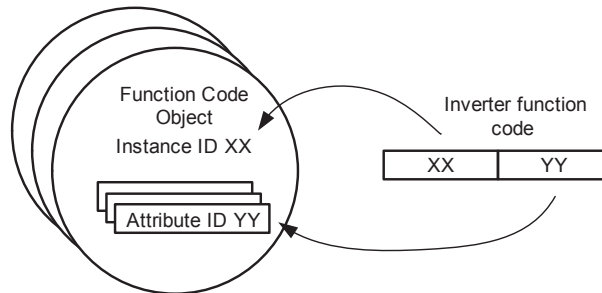

The instance and attribute are calculated using a sequence number of the function group (A = 0, B = 1, etc) * 1000 plus the function code value. The resulting value is allocated to the instance (high byte) and attribute (low byte).

Table E-3 Function Code Object (Class 0x65) Supported Instance and Attribute Codes

Function Code	Decimal base	Decimal range	Hexadecimal range
A001 - A999	0	1 - 999	0001 - 03E7
b001 - b999	1000	1000 - 1999	03E9 - 07CF
C001 - C999	2000	2001 - 2999	07D1 - 0BB7
d001 - d999	3000	3001 - 3999	0BB9 - 0F9F
F001 - F999	5000	5001 - 5999	1389 - 176F
H001 - H999	7000	7001 - 7999	1B59 - 1F3F
P001 - P999	15000	15001 - 15999	3A99 - 3E7F
U001 - U999	20000	20001 - 20999	4E21 - 5207

MX2 Please refer to Appendix B of the MX2 User's Manual (Cat. No. I570)

RX Section 4.4 (Register number list) of the RX User's Manual (Cat. No. I560) for details about Function code references and data sizes.

Note All data written by Function Code or Modbus Register object are stored temporary in the memory of the inverter. Be sure to execute the ENTER command at the end of writing sequence to store the value in EEPROM.

The ENTER command is executed by writing to EEPROM (write 01 Hex to Modbus address 0900 Hex). This operation can be performed by using Modbus Register Object Class.

Function code F001 can not be written using the Function code object. The Function code B127 has a data size of 2 words (different from the Modbus register size of 1 word).

**Example 1:
Reading single word
Function Code**

Parameter:d005 Intelligent input terminal status

Command:

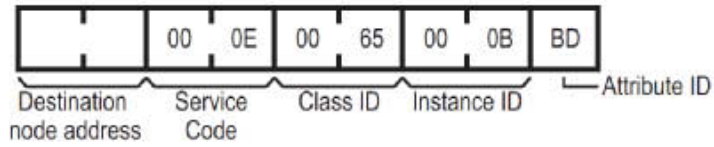

Response:

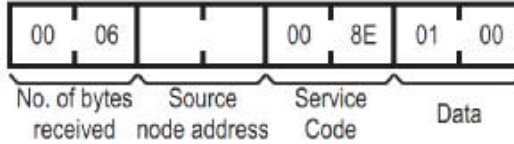

The instance and attribute are determined as value 3 (d) * 1000 + 005 equals 3005 or 0BBD Hex. The response shows input 1 has been set. Please note the swapping of the data following CIP data type encoding.

**Example 2:
Writing double word
Function Code**

Parameter:P060 Multistage position 0 (value 128000, 01F400 Hex)

Command:

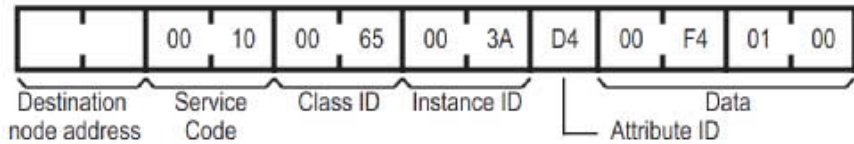

Response:

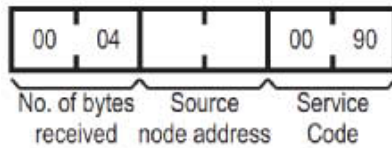

The instance and attribute are determined as value 15 (P) * 1000 + 060 equals 15060 or 3AD4 Hex. Please note the swapping of the data following CIP data type encoding to set decimal value 128000.

E-3 Modbus Register Object (Class 0x64)

E-3-1 Supported Service Codes

Table E-4 Modbus Register Object (0x64) Supported Service Codes

Service Code No. (hex)	Service
0E	Get attribute single
10	Set attribute single

E-3-2 Supported Instance and Attribute Codes

For this Object, the corresponding Modbus register of the inverter parameter are mapped to the object's instance and attribute.

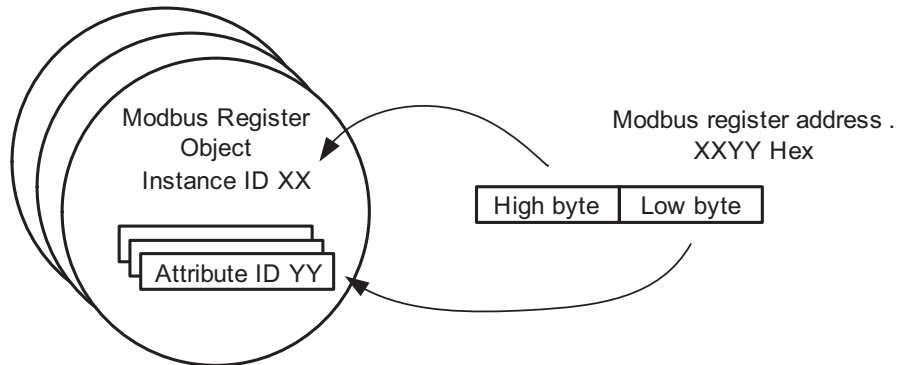

In case of the Modbus Address XXYY Hex, the instance of the object is mapped to XX and the attribute is mapped to YY.

MX2 Please refer to Appendix B of the MX2 User's Manual (Cat. No. I570).

RX Please refer to Section 4.4 (Register number list) of the RX User's Manual (Cat. No. I560) for details about Modbus registers and data sizes.

Note All data written by Function Code or Modbus Register object are stored temporary in the memory of the inverter. Be sure to execute the ENTER command at the end of writing sequence to store the value in EEPROM.

The ENTER command is executed by writing to EEPROM (write 01 Hex to Modbus address 0900 Hex). This operation can be performed by using Modbus Register Object Class.

**Example 1:
Reading single word
Modbus register**

Parameter:Coil data 1 (address 1E01 Hex)

Command:

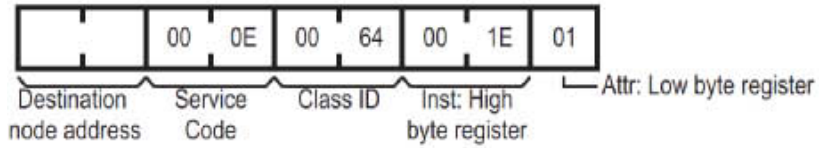

Response:

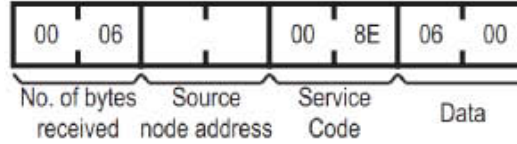

Please note the swapping of the data following CIP data type encoding.

**Example 2:
Writing single word
Modbus register**

Parameter:EEPROM Save parameter 0900 Hex (value 1 Hex)

Command:

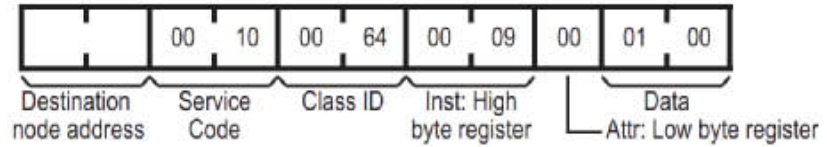

Response:

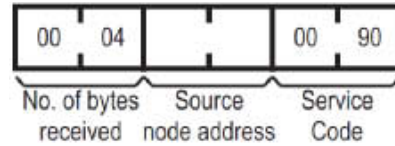

E-4 Explicit Message Error Codes

When an error response has been returned for the executed explicit message, this response will have the following format.

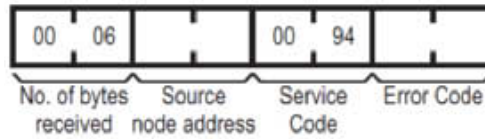

Within the frame, one of the following error codes will be included.

Table E-5 Error Response

Response Code	Error Name	Cause
02□□	Resource unavailable	An internal communication error between Option Board and Inverter
08□□	Service not supported	The service code is incorrect.
09□□	Invalid attribute value	The specified attribute / inverter parameter value is not supported. The data written is outside range.
0C□□	Object state conflict	The specified command cannot be executed due to an internal error.
0E□□	Attribute not settable	An attribute ID supported only for reading has been executed for a write service code.
10□□	Device state conflict	The specified command cannot be executed in this inverter mode.
13□□	Not enough data	The data is smaller than the specified size (accessing only high word of double word).
14□□	Attribute not supported	The attribute or inverter parameter does not exist.
15□□	Too much data	The data is larger than the specified size (accessing single word with double word data).
16□□	Object does not exist	The specified Instance ID is not supported.
1F□□	Vendor specific	This code is returned in case of an Inverter error.
20□□	Invalid parameter	The specified operation command data is not supported.

APPENDIX F Flexible Format

The Flexible Format implements I/O data exchange that supports direct mapping of Inverter Modbus registers in the I/O area. The Flexible Format provides

1. User configurable allocation of the IO Data to any Modbus register
2. Flexibility to set the size of the IO data to only transfer the necessary data, minimising fieldbus traffic.

This offers fieldbus- and profile-independent control of the Inverter.

The exchanged registers are configured by setting Inverter registers P160 to P169 and P170 to P179 to the appropriate Inverter Modbus addresses.

Note The Inverter places some restrictions on the Modbus register selection.

- For a Modbus Register to be mapped for output data exchange, it must be both run-mode editable and writable.
- Inverter parameters may not be accessible depending on the Inverter's mode (Constant Torque mode, Variable Torque mode, etc).

MX2 Refer to the MX2 User's manual, section 3-2-3 and Appendix B-4-2.

RX Refer to the RX User's manual Section "4.4 Register number list" and Appendix 1.

Tip The Inverter parameter B031 (Software Lock Mode) determines the various protection levels. Be sure to set the appropriate value B031 = 10 to be able to set parameter during run-mode.

Tip When using Flexible Format, the Inverter is controlled via Modbus registers. Set A001/A201 = 3 and A002/A202 = 3 to make use of the Modbus control registers for typical Flexible Format use.

Flexible I/O Mapping

Table F-1 Flexible Format I/O Mapping

Word Offset	Content	
	Output Area	Input Area
+0	Modbus register set by P160	Modbus register set by P170
+1	Modbus register set by P161	Modbus register set by P171
+2	Modbus register set by P162	Modbus register set by P172
+3	Modbus register set by P163	Modbus register set by P173
+4	Modbus register set by P164	Modbus register set by P174
+5	Modbus register set by P165	Modbus register set by P175
+6	Modbus register set by P166	Modbus register set by P176
+7	Modbus register set by P167	Modbus register set by P177

Flexible I/O Settings

Please consider the following notes when setting the parameters P160 to P177.

Note 1 The parameters P160 to P167 and P170 to P177 determine the size of the input and output data. The IO size is determined by the highest non-zero parameter. For example for output: if P164 is the highest non-zero parameter, the output data size will be 5 words. Both output as input size should have a minimum size of 1 word and maximum size of 8 words.

Note 2 Setting specific parameters in the range to 0 (not at the end), can be used to reserve IO memory. If set to 0 (zero), an output register is ignored and a 0 (zero) is mapped into an input register.

Note 3 Double-word Inverter registers should be mapped with two Modbus registers in sequence: high-word following low-word.
Mapping only the low word in output data will write zero in the high word of the Inverter register. Mapping only the low word in input data is not allowed.

Note 4 It is not allowed to map the same register more than once in the output area.

Note 5 An incorrect setting of P160 to P167 and P170 to P177 will lead to a Major Recoverable Fault (MS blinking Red) and Inverter trip state E64 (MX2) or E74 (RX). In such case, correct the parameter values and restart (or reset, see *APPENDIX E CompoNet Explicit Messages*) the Unit.

Note 6 Be sure to keep parameters P168, P169, P178 and P179 always to zero.

Tip In case the trip state E64 for MX2 Inverter or E74 for RX is generated, multiple incorrect settings in range P160 - 179 can have caused this error. If the error persists after some changes: it would be convenient to start with a small configuration which is correct and add a new register one by one (checking by restarting the Unit).

Tip Set the following register values:

- P160 = 1F01h: This gives you control over Modbus Coils 0000h through 000Fh using the first output word. These coils implement all the important control functions of the Inverter.
- P161 = 0001h and P162 = 0002h: This gives you control over the frequency reference using output words 2 and 3.
- P170 = 1E01h: This allows you to monitor Modbus Coils 0010h through 001Fh as the first input word. These coils implement the most important status information of the Inverter.
- P171 = 1001h and P172 = 1002h: This allows you to monitor the output frequency using input words 2 and 3.

In case the output data is required to be as small as possible, please consider to only use register 0002h (instead of both 0001h and 0002h) as frequency reference. The resulting configuration is P160 = 1F01h and P161 = 0002h.

MX2 The Modbus coil definitions for the MX2 Inverter are listed in section B-4-1 of the MX2 User's manual (Cat. No. I570).

RX The Modbus coil definitions for the RX Inverter are listed in section 4.4 of the RX User's manual (Cat. No. I560).

Table index

Table 1	Option Board Specification	3
Table 2	MX2 Device List	4
Table 3	RX Device List.	4
Table 4	LED Indicators.	9
Table 5	Ground cable screw selection MX2.	14
Table 6	CompoNet connector signals	20
Table 7	Option Board Dimensions on the MX2 Inverter.	21
Table 8	Option Board Dimensions on the RX Inverter.	21
Table 9	Configuration of Node Number	23
Table 10	Default Connection Path	23
Table 11	Configuration of Inverter Reset Mode Selection	24
Table 12	Configuration of CompoNet Parameters	24
Table 13	Configuration of Source Selection MX2 Parameters.	24
Table 14	Configuration of Source Selection RX Parameters.	24
Table 15	Configuration of Other Selection MX2 Parameters.	25
Table 16	Configuration of Other Selection RX Parameters	25
Table 17	Configuration of Flexible Mapping.	25
Table 14	Extended Speed I/O Output Words.	29
Table 15	Extended Speed I/O Input Words	29
Table 16	Extended Speed Torque I/O Output Words	32
Table 17	Extended Speed Torque I/O Input Words.	33
Table 18	Flex Mode Output Area with Typical Configuration.	36
Table 19	Flex Mode Input Area with Typical Configuration	36
Table 20	Flex Mode Output Area with Motor Running Forward.	37
Table 21	Flex Mode Input Area with Motor Running Forward	37
Table 22	Limitations Caused by Inverter Mode and Rating Selection MX2.	38
Table 23	Limitations Caused by Inverter Mode and Rating Selection RX	38
Table 24	Option Board or Inverter Errors on the Inverter.	40
Table 25	Configuration Errors on the Inverter	41
Table 26	CompoNet Errors on the Inverter	43
Table 27	Other errors.	44
Table B-1	Basic Speed Control Output - Assembly 20 Allocation	55
Table B-2	Basic Speed Control Output - Assembly 20 Description.	55
Table B-3	Basic Speed Control Input - Assembly 70 Allocation	55
Table B-4	Basic Speed Control Input - Assembly 70 Description	55
Table B-5	Extended Speed Control Output - Assembly 21 Allocation.	57
Table B-6	Extended Speed Control Output - Assembly 21 Description	57
Table B-7	Extended Speed Control Input - Assembly 71 Allocation	57
Table B-8	Extended Speed Control Input - Assembly 71 Description	57
Table B-9	Extended Speed and Torque Control Output - Assembly 123 Allocation	59
Table B-10	Extended Speed and Torque Control Output - Assembly 123 Description	59
Table B-11	Extended Speed and Torque Control Input - Assembly 173 Allocation	59
Table B-12	Extended Speed and Torque Control Input - Assembly 173 Description	60
Table B-13	Special Output - Assembly 100 Allocation	61
Table B-14	Special Output - Assembly 100 Description	61
Table B-15	Special Input - Assembly 150 Allocation.	61
Table B-16	Special Input - Assembly 150 Description.	61
Table B-17	Special Input - Assembly 150 Errors.	62
Table B-18	Extended Control Output - Assembly 101 Allocation	63
Table B-19	Extended Control Output - Assembly 101 Description	63
Table B-20	Extended Control Input - Assembly 151 Allocation.	64
Table B-21	Extended Control Input - Assembly 151 Description.	64
Table B-22	Extended Control + Multi Function Input - Assembly 153 Allocation	65
Table B-23	Extended Control + Multi Function Input - Assembly 153 Description	65
Table B-24	Extended Speed and Acceleration Control Output - Assembly 110 Allocation.	66

Table B-25	Extended Speed and Acceleration Control Output - Assembly 110 Description	66
Table B-26	Extended Speed and Acceleration Control Input - Assembly 111 Allocation	67
Table B-27	Extended Speed and Acceleration Control Input - Assembly 111 Description	67
Table C-1	Identity Object - Supported Service Codes	69
Table C-2	Identity Object - Object Details	69
Table C-3	Model List MX2	70
Table C-4	Model List RX	70
Table C-5	Assembly Object - Supported Service Codes	73
Table C-6	Assembly Object - Object Details	73
Table C-7	Connection Object - Supported Service Codes	74
Table C-8	Connection Object - Object Details	74
Table C-9	Discrete Input Point Object - Supported Service Codes	75
Table C-10	Discrete Input Point Object - Object Details	75
Table C-11	Discrete Output Point Object - Supported Service Codes	75
Table C-12	Discrete Output Point Object - Object Details	75
Table C-13	Unit Parameter Object - Supported Service Codes	76
Table C-14	Unit Parameter Object - Object Details	76
Table C-15	CompoNet Link Object - Supported Service Code	76
Table C-16	CompoNet Link Object - Object Details	76
Table D-1	Motor Data Object - Supported Service Codes	77
Table D-2	Motor Data Object - Object Details	77
Table D-3	Control Supervisor Object - Supported Service Codes	78
Table D-4	Control Supervisor Object - Object Details	78
Table D-5	Error Code Conversion	79
Table D-6	AC/DC Drive Object - Supported Service Codes	81
Table D-7	AC/DC Drive Object - Object Details	81
Table E-1	Service Codes	83
Table E-2	Function Code Object (Class 0x65) Supported Service Codes	85
Table E-3	Function Code Object (Class 0x65) Supported Instance and Attribute Codes	85
Table E-4	Modbus Register Object (0x64) Supported Service Codes	87
Table E-5	Error Response	89
Table F-1	Flexible Format I/O Mapping	91

Revision history

A manual revision code appears as a suffix to the catalog number on the front cover of the manual.

Cat. No. I114E-EN-02

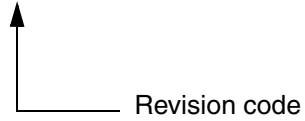

The following table outlines the changes made to the manual during each revision. Page numbers refer to the previous version.

Revision code	Date	Revised content
02	Aug 2011	Added RX Option Board 3G3AX-RX-CRT-E description
01	Jul 2010	Original production