



**EMERSON**<sup>™</sup>  
Industrial Automation



*Technical Data Guide*

# **Commander SK**

*Model sizes A to D and 2 to 6*

AC variable speed drive for 3  
phase induction motors

Part Number: 0472-0002-09

Issue: 9



[www.controltechniques.com](http://www.controltechniques.com)

## General Information

The manufacturer accepts no liability for any consequences resulting from inappropriate, negligent or incorrect installation or adjustment of the optional operating parameters of the equipment or from mismatching the variable speed drive with the motor.

The contents of this guide are believed to be correct at the time of printing. In the interests of a commitment to a policy of continuous development and improvement, the manufacturer reserves the right to change the specification of the product or its performance, or the contents of the guide, without notice.

All rights reserved. No parts of this guide may be reproduced or transmitted in any form or by any means, electrical or mechanical including photocopying, recording or by an information storage or retrieval system, without permission in writing from the publisher.

## Drive software version

This product is supplied with the latest software version. If this drive is to be connected to an existing system or machine, all drive software versions should be verified to confirm the same functionality as drives of the same model already present. This may also apply to drives returned from a Control Techniques Service Centre or Repair Centre. If there is any doubt please contact the supplier of the product.

The software version of the drive can be checked by looking at Pr **11.29** and Pr **11.34**. This takes the form of xx.yy.zz where Pr **11.29** displays xx.yy and Pr **11.34** displays zz. (e.g. for software version 01.01.00, Pr **11.29** = 1.01 and Pr **11.34** displays 0).

## Environmental statement

Control Techniques is committed to minimising the environmental impacts of its manufacturing operations and of its products throughout their life cycle. To this end, we operate an Environmental Management System (EMS) which is certified to the International Standard ISO 14001. Further information on the EMS, our Environmental Policy and other relevant information is available on request, or can be found at [www.greendrives.com](http://www.greendrives.com).

The electronic variable-speed drives manufactured by Control Techniques have the potential to save energy and (through increased machine/process efficiency) reduce raw material consumption and scrap throughout their long working lifetime. In typical applications, these positive environmental effects far outweigh the negative impacts of product manufacture and end-of-life disposal.

Nevertheless, when the products eventually reach the end of their useful life, they must not be discarded but should instead be recycled by a specialist recycler of electronic equipment. Recyclers will find the products easy to dismantle into their major component parts for efficient recycling. Many parts snap together and can be separated without the use of tools, whilst other parts are secured with conventional fasteners. Virtually all parts of the product are suitable for recycling.

Product packaging is of good quality and can be re-used. Large products are packed in wooden crates, while smaller products come in strong cardboard cartons which themselves have a high recycled fibre content. If not re-used, these containers can be recycled. Polythene, used on the protective film and bags for wrapping product, can be recycled in the same way. Control Techniques' packaging strategy prefers easily-recyclable materials of low environmental impact, and regular reviews identify opportunities for improvement.

When preparing to recycle or dispose of any product or packaging, please observe local legislation and best practice.

## REACH legislation

EC Regulation 1907/2006 on the Registration, Evaluation, Authorisation and restriction of Chemicals (REACH) requires the supplier of an article to inform the recipient if it contains more than a specified proportion of any substance which is considered by the European Chemicals Agency (ECHA) to be a Substance of Very High Concern (SVHC) and is therefore listed by them as a candidate for compulsory authorisation.

For current information on how this requirement applies in relation to specific Control Techniques products, please approach your usual contact in the first instance. Control Techniques position statement can be viewed at:

<http://www.controltechniques.com/REACH>

---

# Contents

---

<b>1</b>	<b>Technical data</b> .....	<b>5</b>
1.1	Commander SK size A to D .....	5
1.2	Commander SK size 2 to 6 .....	9
<b>2</b>	<b>Derating curves and losses</b> .....	<b>18</b>
2.1	Size A .....	18
2.2	Size B .....	21
2.3	Size C .....	26
2.4	Size D .....	28
2.5	Size 2 .....	31
2.6	Size 3 .....	33
2.7	Size 4 .....	35
2.8	Size 5 .....	37
2.9	Size 6 .....	38
2.10	Derating with glanding box and Cover kit (size A only) .....	39
<b>3</b>	<b>Drive voltage levels</b> .....	<b>40</b>
3.1	Input voltage .....	41
3.2	Single phase ratings (size 2 and 3) .....	41
<b>4</b>	<b>DC bus design</b> .....	<b>42</b>
4.1	Commander SK size A to D .....	42
4.2	Commander SK size 2 to 6 .....	42
<b>5</b>	<b>Mechanical installation</b> .....	<b>44</b>
5.1	Mounting methods .....	44
5.2	Enclosing standard drive for high environmental protection .....	60
5.3	Sizing a braking resistor .....	71
<b>6</b>	<b>EMC</b> .....	<b>78</b>
6.1	Ground leakage .....	78
6.2	Internal EMC filter .....	79
6.3	Electromagnetic compatibility (EMC) .....	80
6.4	Commander SK size A to D .....	81
6.5	Commander SK size 2 to 6 .....	87
<b>7</b>	<b>AC line reactors</b> .....	<b>104</b>
7.1	Line reactors .....	104
7.2	Reactor current ratings .....	105
7.3	Input line reactors for harmonics standards EN 61000-3-2:2006 and IEC61000-3-2 .....	105
<b>8</b>	<b>Motor cable lengths</b> .....	<b>107</b>
8.1	Commander SK size A to D .....	107
8.2	Commander SK size 2 to 6 .....	107

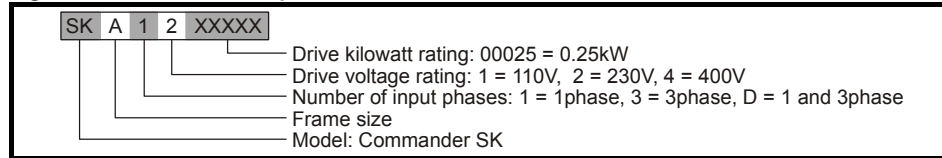
<b>9</b>	<b>General data .....</b>	<b>109</b>
9.1	Ratings .....	109
9.2	Input phase imbalance .....	109
9.3	Ambient temperature .....	109
9.4	Storage .....	109
9.5	Altitude .....	109
9.6	Environmental protection rating .....	109
9.7	Humidity .....	109
9.8	Storage humidity .....	109
9.9	Pollution degree .....	109
9.10	Materials .....	109
9.11	Corrosive gases .....	109
9.12	Vibration .....	110
9.13	Frequency accuracy .....	110
9.14	Resolution .....	110
9.15	Output frequency range .....	110
9.16	Starts per hour .....	110
9.17	Start-up time .....	110
9.18	Serial communications .....	110
9.19	Switching frequencies .....	110
9.20	Harmonics .....	110
9.21	Acoustic noise .....	110
<b>10</b>	<b>I/O specification .....</b>	<b>111</b>
10.1	Drive reset .....	113
10.2	Sample/update times .....	113
10.3	Task routine times .....	113
<b>11</b>	<b>Supply types.....</b>	<b>114</b>
11.1	AC supply requirements .....	114
11.2	Safety .....	114
11.3	Cables .....	114
11.4	Fuses .....	115
11.5	Ground connections .....	115
<b>12</b>	<b>Options .....</b>	<b>117</b>



# 1 Technical data

## 1.1 Commander SK size A to D

Figure 1-1 Model code explanation



### 1.1.1 Commander SK 110V size A and B units

Table 1-1 Ratings

Model	SKA11		SKB11	
	00025	00037	00075	00110
AC supply voltage and frequency	Single phase 100 to 120V ±10% 48Hz to 62Hz			
Input displacement factor (cos $\phi$ )	>0.97			
Nominal motor power (kW)	0.25	0.37	0.75	1.1
Nominal motor power (hp)	0.33	0.5	1.0	1.5
Output voltage and frequency	3 phase, 0 to drive rating (240), 0 to 150Hz**			
100% RMS output current (A)	1.7	2.2	4.0	5.2
150% overload current for 60s (A)	2.55	3.3	6.0	7.8
Typical full load input current (A)	7.5	11	19.6	24.0
Maximum continuous input current (A)*				
Typical inrush current (A) (<10ms)	<10		12.5	
Weight (kg)	1.0		1.356	
Weight (lb)	2.2		3	
Internal EMC filter	Yes			
DC bus terminals	No			
Din rail mounting	Yes			

\* For 3 phase input only, allowing for supply imbalance up to 2% negative phase sequence.

\*\* The 110V drives use a voltage doubler circuit on the input.

Table 1-2 Cables

Model		SKA11		SKB11	
		00025	00037	00075	00110
Recommended input supply fuse (A)	IEC gG	10	16	25	32
	Class CC	10	15	25	30
Control cable****	mm <sup>2</sup>	>0.5			
	AWG	20			
Recommended input cable*****	mm <sup>2</sup>	1.0	1.5	4.0	
	AWG	16	14	10	
Recommended motor cable*****	mm <sup>2</sup>	1.0			
	AWG	16			
Recommended brake resistor*****	mm <sup>2</sup>	1.0			
	AWG	16			

\*\*\*\*\* The maximum size of wire for the power terminals is 2.5mm<sup>2</sup> (Size A), 4mm<sup>2</sup> (Size B and C) and 6mm<sup>2</sup> (size D)

Table 1-3 Braking resistor

Model	SKA11		SKB11	
	00025	00037	00075	00110
Minimum braking resistor value ( $\Omega$ )*****	N/A	N/A	28	
Recommended braking resistor value ( $\Omega$ )	N/A	N/A	100	
Resistor peak power rating (kW)	N/A	N/A	1.7	
Maximum braking current (A)	N/A	N/A	14.8	

\*\*\*\*\* Resistor tolerance ±10%

No dynamic braking available on the 110V Size A.

Technical data	Derating curves and losses	Drive voltage levels	DC bus design	Mechanical installation	EMC	AC line reactors	Motor cable lengths	General data	I/O specification	Supply types	Options
----------------	----------------------------	----------------------	---------------	-------------------------	-----	------------------	---------------------	--------------	-------------------	--------------	---------

**Table 1-4 Cooling fan**

Model		SKA11		SKB11	
		00025	00037	00075	00110
Cooling fan installed		No		Yes	
Air flow	feet <sup>3</sup> /minute			10.6	
	m <sup>3</sup> /minute			0.3	

**1.1.2 Commander SK 200V size A to D units**

**Table 1-5 Ratings**

Model	SKA12				SKBD2				SKCD2		SKD		
	00025	00037	00055	00075	00110		00150		00220		D200300		3200400
					1ph	3ph	1ph	3ph	1ph	3ph	1ph	3ph	3ph
AC supply voltage and frequency	Single phase 200 to 240V ±10% 48Hz to 62Hz				Single or 3 phase 200 to 240V ±10% 48Hz to 62Hz				Single or 3 phase 200 to 240V ±10% 48Hz to 62Hz		3 phase 200 to 240V ±10% 48Hz to 62Hz		
Input displacement factor (cos∅)	>0.97												
Nominal motor power (kW)	0.25	0.37	0.55	0.75	1.1	1.5	2.2	3		4			
Nominal motor power (hp)	0.33	0.50	0.75	1.0	1.5	2.0	3.0	3		5			
Output voltage and frequency	3 phase, 0 to drive rating (240), 0 to 1500Hz												
100% RMS output current (A)	1.7	2.2	3.0	4.0	5.2	7.0	9.6	12.6		17			
150% overload current for 60s (A)	2.6	3.3	4.5	6	7.8	10.5	14.4	18.9		25.5			
Typical full load input current (A)	4.3	5.8	8.1	10.5	14.2	6.7	17.4	8.7	23.2	11.9	23.6	12.5	15.7
Maximum continuous input current (A)*					9.2	12.6	17			16.6	19.5		
Typical inrush current (A) (<10ms)	17.0				27.4				18.3		19.1		
Weight (kg)	0.95		1.0		1.3	1.4	2.1	4.5		9.9			
Weight (lb)	2.1		2.2		2.9	3.1	4.6	9.9					
Internal EMC filter	Yes												
DC bus terminals	No				Yes								
Din rail mounting	Yes								No				

\* For 3 phase input only, allowing for supply imbalance up to 2% negative phase sequence.

**Table 1-6 Cables**

Model		SKA12				SKBD2				SKCD2		SKD		
		00025	00037	00055	00075	00110		00150		00220		D200300		3200400
						1ph	3ph	1ph	3ph	1ph	3ph	1ph	3ph	1ph
Recommended input supply fuse (A)	IEC gG	6	10	16	16	10	20	16	25	20	25	16	20	
	Class CC	5	10	15	15	10	20	15	25	20	25	15	20	
Control cable****	mm <sup>2</sup>	≥0.5				≥0.5				≥0.5				
	AWG	20				20				20				
Recommended input cable*****	mm <sup>2</sup>	1.0		1.5	2.5	1.5	2.5	1.5	4.0	2.5	6	2.5	2.5	
	AWG	16		14	12	14	12	14	10	12	10	12	12	
Recommended motor cable*****	mm <sup>2</sup>	1.0				1.0				1.5		2.5		
	AWG	16				16				14		14	12	
Recommended brake resistor*****	mm <sup>2</sup>	1.0				1.0				1.5		2.5		
	AWG	16				16				14		14		

\*\*\*\* The maximum size of wire for the control terminals is 2.5mm<sup>2</sup>

\*\*\*\*\* The maximum size of wire for the power terminals is 2.5mm<sup>2</sup> (Size A), 4mm<sup>2</sup> (Size B and C) and 6mm<sup>2</sup> (size D)

**Table 1-7 Braking resistor**

Model	SKA12				SKBD2		SKCD2	SKD	
	00025	00037	00055	00075	00110	00150	00220	D200300	3200400
Minimum braking resistor value (Ω)*****	68				28		28	20	20
Recommended braking resistor value (Ω)	200			150	100		50	40	30
Resistor peak power rating (kW)	0.9			1.1	1.7		3.4	4.3	5.8
Maximum braking current (A)	6.1				14.8		14.8	20	20

\*\*\*\*\* Resistor tolerance ±10%

**Table 1-8 Cooling fan**

Model		SKA12				SKBD2		SKCD2	SKD	
		00025	00037	00055	00075	00110	00150	00220	D200300	3200400
Cooling fan installed		No				Yes		Yes	Yes	
Air flow	feet <sup>3</sup> /minute					10.6			30	30
	m <sup>3</sup> /minute					0.3			0.84	0.84

**1.1.3 Commander SK 400V size B to D units**

**Table 1-9 Ratings**

Model	SKB34					SKC34			SKD34	
	00037	00055	00075	00110	00150	00220	00300	00400	00550	00750
AC supply voltage and frequency	3 phase 380 to 480V ±10% 48Hz to 62Hz								3 phase 380 to 480V ±10% 48Hz to 62Hz	
Input displacement factor (cosφ)	>0.97									
Nominal motor power (kW)	0.37	0.55	0.75	1.1	1.5	2.2	3.0	4.0	5.5	7.5
Nominal motor power (hp)	0.5	0.75	1.0	1.5	2.0	3.0	3.0	5.0	7.5	10
Output voltage and frequency	3 phase, 0 to drive rating (480), 0 to 1500Hz									
100% RMS output current (A)	1.3	1.7	2.1	2.8	3.8	5.1	7.2	9.0	13	16.5
150% overload current for 60s (A)	2	2.6	3.2	4.2	5.7	7.7	10.8	13.5	19.5	24.75
Typical full load input current (A)	1.7	2.5	3.1	4	5.2	7.3	9.5	11.9	12.4	15.6
Maximum continuous input current (A)*	2.5	3.1	3.75	4.6	5.9	9.6	11.2	13.4	14.3	16.9
Typical inrush current (A) (<10ms)	17.0					11.3			12	
Weight (kg)	1.2			1.3		2.1			4.7	
Weight (lb)	2.7			2.9		4.6			10.4	
Internal EMC filter	Yes									
DC bus terminals	Yes									
Din rail mounting	Yes					No				

\* For 3 phase input only, allowing for supply imbalance up to 2% negative phase sequence.

**Table 1-10 Cables**

Model		SKB34					SKC34			SKD34	
		00037	00055	00075	00110	00150	00220	00300	00400	00550	00750
Recommended input supply fuse (A)	IEC gG	6				10	16			16	20
	Class CC	5				10	15			15	20
Control cable****	mm <sup>2</sup>	≥0.5					≥0.5			≥0.5	
	AWG	20					20			20	
Recommended input cable *****	mm <sup>2</sup>	1.0					1.5	2.5	2.5		
	AWG	16					14	12	14	12	
Recommended motor cable*****	mm <sup>2</sup>	1.0					1.0	1.5	2.5		
	AWG	16					16	14	14	12	
Recommended brake resistor cable*****	mm <sup>2</sup>	1.5					1.5			2.5	
	AWG	14					14			12	

\*\*\*\* The maximum size of wire for the control terminals is 2.5mm<sup>2</sup>

\*\*\*\*\* The maximum size of wire for the power terminals is 2.5mm<sup>2</sup> (Size A), 4mm<sup>2</sup> (Size B and C) and 6mm<sup>2</sup> (size D)

**Table 1-11 Braking resistor**

Model	SKB34					SKC34			SKD34	
	00037	00055	00075	00110	00150	00220	00300	00400	00550	00750
Minimum braking resistor value (Ω)*****	100					100	55		53	
Recommended braking resistor value (Ω)	200					200	150	100	80	55
Resistor peak power rating (kW)	3.4					3.4	4.6	6.9	8.7	12.6
Maximum braking current (A)	8.3					8.3	15.1		15.7	

\*\*\*\*\* Resistor tolerance ±10%

**NOTE**

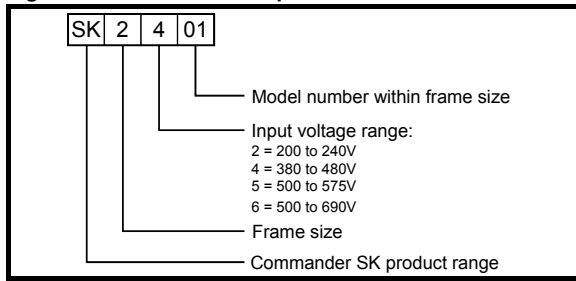
The correct UL listed high speed / fast acting fuses (class CC or class J up to 30A and class J above 30A) can be used.

**Table 1-12 Cooling fan**

Model		SKB34					SKC34			SKD34	
		00037	00055	00075	00110	00150	00220	00300	00400	00550	00750
Cooling fan installed		No			Yes		Yes			Yes	
Air flow	feet <sup>3</sup> /minute				10.6			30		30	
	m <sup>3</sup> /minute				0.3			0.84		0.84	

## 1.2 Commander SK size 2 to 6

Figure 1-2 Model code explanation

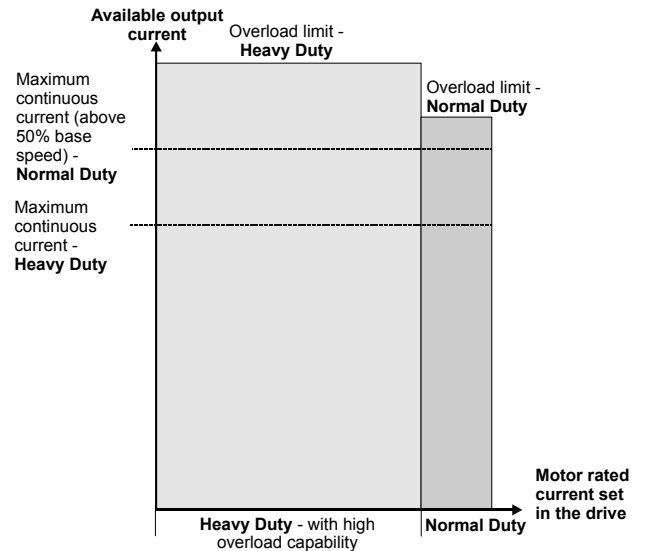


The Commander SK sizes 2 to 6 are dual rated.

The setting of the motor rated current determines which rating applies - Heavy Duty or Normal Duty.

The two ratings are compatible with motors designed to IEC60034.

The graph aside illustrates the difference between Normal Duty and Heavy Duty with respect to continuous current rating and short term overload limits.



### Normal Duty

For applications which use self ventilated induction motors and require a low overload capability (e.g. fans, pumps).

Self ventilated induction motors require increased protection against overload due to the reduced cooling effect of the fan at low speed. To provide the correct level of protection the  $I^2t$  software operates at a level which is speed dependent. This is illustrated in the graph below.

#### NOTE

The speed at which the low speed protection takes effect can be changed by the setting of Pr 4.25. The protection starts when the motor speed is below 15% of base speed when Pr 4.25 = 0 (default) and below 50% when Pr 4.25 = 1. See the *Commander SK Advanced User Guide*, Menu 4 for further details.

### Heavy Duty (default)

For constant torque applications or applications which require a high overload capability (e.g. cranes, hoists).

The thermal protection is set to protect force ventilated induction motors by default.

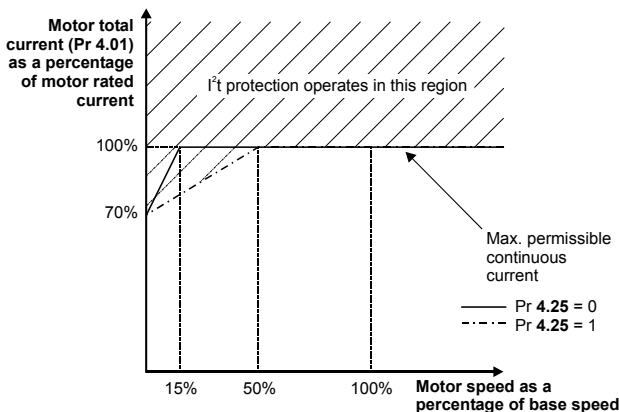
#### NOTE

If the application uses a self ventilated motor and increased thermal protection is required for speeds below 50% base speed, then this can be enabled by setting Pr 4.25 = 1. See the *Commander SK Advanced User Guide*, Menu 4 for further details.

### Operation of motor $I^2t$ protection (lt.AC trip)

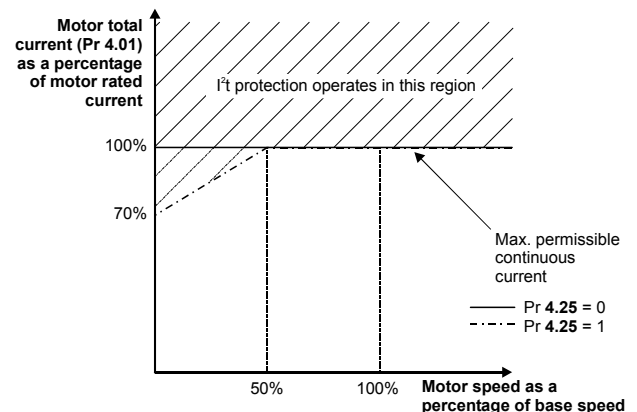
Motor  $I^2t$  protection is fixed as shown below and is compatible with:

- Self ventilated induction motors



Motor  $I^2t$  protection defaults to be compatible with:

- Forced ventilation induction motors



### 1.2.1 Typical short term overload limits

The maximum percentage overload limit changes depending on the induction motor only. Variations in motor rated current, motor rated power factor and motor leakage inductance all result in changes in the maximum possible overload. The exact value for a specific motor can be calculated using the equations detailed in Menu 4 in the *Commander SK Advanced User Guide*.

**Table 1-13 Typical overload limits for size 2 to 5**

	From cold	From 100% full load
Normal duty overload with motor rated current = drive rated current	110% for 215s	110% for 5s
Heavy duty overload with motor rated current = drive rated current	150% for 60s	150% for 8s

**Table 1-14 Typical overload limits for size 6**

	From cold	From 100% full load
Normal duty overload with motor rated current = drive rated current	110% for 165s	110% for 9s
Heavy duty overload with motor rated current = drive rated current	129% for 97s	129% for 15s

Generally the drive rated current is higher than the matching motor rated current allowing a higher level of overload than the default setting as illustrated by the example of a typical 4 pole motor.

The time allowed in the overload region is proportionally reduced at very low output frequency on some drive ratings.

**NOTE**

The maximum overload level which can be attained is independent of the speed.

### 1.2.2 Commander SK 200V size 2 to 4 units

**Key:**

♦ Refer to Table 1-13 on page 10 for typical overload limits

\* Typical input current

The values of typical input current are given to aid calculations for power flow and power loss (Normal Duty rating).

The values of typical input current are stated for a balanced supply.

\*\* Maximum continuous input current

The values of maximum continuous input current are given to aid the selection of cables and fuses. These values are stated for the worse case condition with the unusual combination of a stiff supply with bad balance (Normal Duty rating). The value stated for the maximum continuous input current would only be seen in one of the input phases. The current in the other two phases would be significantly lower.

The values of maximum input current are stated with a 2% negative phase-sequence imbalance and rated at the maximum supply fault current given in the following tables.

\*\*\*\* Resistor tolerance  $\pm 10\%$

^ Semi-conductor fuse in series with HRC fuse or circuit breaker

**Table 1-15 Size 2 to 4 ratings**

Model	SK2			SK3		SK4		
	201	202	203	201	202	201	202	203
AC supply voltage and frequency	3 phase 200 to 240Vac $\pm 10\%$ 48 to 65Hz							
Input displacement factor (cos $\phi$ )	>0.97							
<b>Normal duty</b>								
Nominal motor power at 220V (kW)	4.0	5.5	7.5	11	15	18.5	22	30
Nominal motor power at 230V (hp)	5.0	7.5	10	15	20	25	30	40
100% RMS output current (A)	15.5	22	28	42	54	68	80	104
<b>Heavy Duty</b>								
Nominal motor power at 220V (kW)	3.0	4.0	5.5	7.5	11	15	18.5	22
Nominal motor power at 230V (hp)	3.0	5.0	7.5	10	15	20	25	30
100% RMS output current (A)	12.6	17	25	31	42	56	68	80
Peak current (A) ♦	18.9	25.5	37.5	46.5	63	84	102	120
Typical full load input current (A) *	13.4	18.2	24.2	35.4	46.8	62.1	72.1	94.5
Maximum continuous input current (A) **	18.1	22.6	28.3	43.1	54.3	68.9	78.1	99.9
Typical inrush current (A)	12			8		73		
Maximum supply fault current (kA)	100							
Weight (kg)	7			15		30		
Weight (lb)	15.4			33.1		66.1		

**Table 1-16 Size 2 and 3 fuses**

Model		SK2			SK3	
		201	202	203	201	202
Recommended input supply fuse (A)	IEC gG	20	25	32	50	63
	Class CC	20	25			
	Class J			30	45	60

**Table 1-17 Size 4 fuses**

Model		SK4					
		201	202	203	201	202	203
		Option 1			Option 2^		
Recommended input supply fuse (A)	IEC gR	100	100	125			
	Ferraz HSJ	90	100	125			
	IEC gG UL class J				90	100	125
	IEC class aR				160	160	200

**Table 1-18 Size 2 to 4 cables**

Model		SK2			SK3		SK4			
		201	202	203	201	202	201	202	203	
Control cable	mm <sup>2</sup>	≥0.5								
	AWG	20								
Recommended input cable	mm <sup>2</sup>	4.0	4.0	6.0	16	25	25	35	70	
	AWG	12	10	8	6	4	3	3	1	
Recommended motor cable	mm <sup>2</sup>	2.5	4.0	6.0	16	25	25	35	70	
	AWG	14	10	8	6	4	3	3	1	
Recommended brake resistor	mm <sup>2</sup>	2.5	4.0	6.0	16	25	25	35	70	
	AWG	14	10	8	6	4	3	3	1	

**Table 1-19 Braking resistor (minimum resistance values and peak power rating for the braking resistor at 40°C)**

Model		SK2			SK3		SK4		
		201	202	203	201	202	201	202	203
Minimum braking resistor value (Ω)****		18			5.0		5.0		
Resistor peak power rating (kW)		8.9			30.3		30.3		
Average power for 60s (kW)		6.0	8.0	8.9	13.1	19.3	22.5	27.8	30.3

**Table 1-20 Cooling fan**

Model		SK2			SK3		SK4		
		201	202	203	201	202	201	202	203
Air flow	m <sup>3</sup> /hour	65			150		200		

**NOTE**

The class J fuses should be high speed or fast acting only.

### 1.2.3 Commander SK 400V size 2 to 6 units

**Key:**

◆ Refer to Table 1-13 and Table 1-14 on page 10 for typical overload limits

\* Typical input current

The values of typical input current are given to aid calculations for power flow and power loss (Normal Duty rating).  
The values of typical input current are stated for a balanced supply.

\*\* Maximum continuous input current

The values of maximum continuous input current are given to aid the selection of cables and fuses. These values are stated for the worse case condition with the unusual combination of a stiff supply with bad balance (Normal Duty rating). The value stated for the maximum continuous input current would only be seen in one of the input phases. The current in the other two phases would be significantly lower.

The values of maximum input current are stated with a 2% negative phase-sequence imbalance and rated at the maximum supply fault current given in the following tables.

\*\*\* SK2404 Power and current ratings

Commander SK size 2 to 6 are dual rated except for the SK2404 which only has a Heavy Duty rating. However, if the current limit in Pr 4.07 is set to a maximum of 110% and the switching frequency is greater than 3kHz, then the drive can be used at a maximum continuous current higher than the Heavy Duty rating. Normal Duty ratings exist for the SK2404 above 3kHz when the overload is reduced from the default value of 165% to 110%.

If the current limit in Pr 4.07 is set higher than 110% then the Heavy Duty current ratings are applicable.

\*\*\*\* Resistor tolerance  $\pm 10\%$

^ Semi-conductor fuse in series with HRC fuse or circuit breaker

^^ The minimum resistance value specified is for a stand-alone drive only. If the drive is part of a common DC bus system a different value must be used. Contact the supplier of the drive for more information

**Table 1-21 Size 2 to 4 ratings**

Model	SK2				SK3			SK4		
	401	402	403	404***	401	402	403	401	402	403
AC supply voltage and frequency	3 phase 380 to 480Vac $\pm 10\%$ 48 to 65Hz									
Input displacement factor (cos $\phi$ )	>0.97									
<b>Normal Duty</b>										
Nominal motor power at 400V (kW)	7.5	11	15		18.5	22	30	37	45	55
Nominal motor power at 460V (hp)	10	15	20		25	30	40	50	60	75
100% RMS output current (A)	15.3	21	29		35	43	56	68	83	104
<b>Heavy Duty</b>										
Nominal motor power at 400V (kW)	5.5	7.5	11	15	15	18.5	22	30	37	45
Nominal motor power at 460V (hp)	7.5	10	20	20	25	30	30	50	60	75
100% RMS output current (A)	13	16.5	25	29	32	40	46	60	74	96
Peak current (A) ◆	19.5	24.7	34.5	43.5	48	60	69	90	111	144
Typical full load input current (A) *	15.7	20.2	26.6	26.6	34.2	40.2	51.3	61.2	76.3	94.1
Maximum continuous input current (A) **	17	21.4	27.6	27.6	36.2	42.7	53.5	62.3	79.6	97.2
Typical inrush current (A)	24				14			37	73	
Maximum supply fault current (kA)	100				100			100		
Weight (kg)	7				15			30		
Weight (lb)	15.4				33.1			66.1		



**Table 1-22 Size 5 and 6 ratings**

Model	SK5				SK6			
	401	402	401	402				
AC supply voltage and frequency	3 phase 380 to 480Vac ±10% 48 to 65Hz							
Input displacement factor (cos φ)	>0.97							
<b>Normal Duty</b>								
Nominal motor power at 400V (kW)	75	90	110	132				
Nominal motor power at 460V (hp)	100	125	150	200				
100% RMS output current (A)	138	168	205	236				
<b>Heavy Duty</b>								
Nominal motor power at 400V (kW)	55	75	90	110				
Nominal motor power at 460V (hp)	100	125	150	150				
100% RMS output current (A)	124	156	180	210				
Peak current (A) ♦	186	234	231	270				
Typical full load input current (A) *	126	152	224	247				
Maximum continuous input current (A) **	131	156	241	266				
Typical inrush current (A)	110							
Maximum supply fault current (kA)	100							
Weight (kg)	55							
Weight (lb)	121.3							

**Table 1-23 Size 2 and 3 fuses**

Model		SK2				SK3		
		401	402	403	404	401	402	403
Recommended input supply fuse (A)	IEC gG	20	25	32	32	40	50	63
	Class CC	20	25					
	Class J			30	30	40	45	60

**Table 1-24 Size 4 to 6 fuses**

Model		SK4						SK5				SK6			
		401	402	403	401	402	403	401	402	401	402	401	402	401	402
		Option 1			Option 2^			Option 1		Option 2^		Option 1		Option 2^	
Recommended input supply fuse (A)	IEC gR	80	110	125				200	250			315	315		
	Ferraz HSJ	80	110	125				175	225			300	300		
	IEC gG				80	100	125			160	200			250	300
	UL class J														
	IEC class aR				160	200	200			200	250			315	350

**Table 1-25 Size 2 to 4 cables**

Model		SK2				SK3			SK4		
		401	402	403	404	401	402	403	401	402	403
Control cable	mm²	≥0.5									
	AWG	20									
Recommended input cable	mm²	4.0	4.0	6.0	6.0	10	16	25	25	35	70
	AWG	12	10	8	8	6	6	4	3	2	1
Recommended motor cable	mm²	2.5	4.0	6.0	6.0	10	16	25	25	35	70
	AWG	14	10	8	8	6	6	4	3	2	1
Recommended brake resistor	mm²	2.5	4.0	6.0	6.0	10	16	25	25	35	70
	AWG	14	10	8	8	6	6	4	3	2	1

Technical data	Derating curves and losses	Drive voltage levels	DC bus design	Mechanical installation	EMC	AC line reactors	Motor cable lengths	General data	I/O specification	Supply types	Options
----------------	----------------------------	----------------------	---------------	-------------------------	-----	------------------	---------------------	--------------	-------------------	--------------	---------

**Table 1-26 Size 5 and 6 cables**

Model		SK5		SK6	
		401	402	401	402
Control cable	mm <sup>2</sup>	≥0.5			
	AWG	20			
Recommended input cable	mm <sup>2</sup>	95	120	2 x 70	2 x 120
	AWG	2/0	4/0	2 x 2/0	2 x 4/0
Recommended motor cable	mm <sup>2</sup>	95	120	2 x 70	2 x 120
	AWG	2/0	4/0	2 x 2/0	2 x 4/0
Recommended brake resistor	mm <sup>2</sup>	95	120	2 x 70	2 x 120
	AWG	2/0	4/0	2 x 2/0	2 x 4/0

**Table 1-27 Braking resistor (minimum resistance values and peak power rating for the braking resistor at 40°C)**

Model	SK2				SK3			SK4^^			SK5^^		SK6		
	401	402	403	404	401	402	403	401	402	403	401	402	401	402	
Minimum braking resistor value (Ω)****	19				18			11		9	7		5		
Resistor peak power rating (kW)	33.1				35.5			55.3		67.6		86.9		121.7	
Average power for 60s (kW)	9.6	13.1	19.3	22.5	22.5	27.8	33.0	45.0	53.0	67.5	82.5	86.9	90	110	

**Table 1-28 Cooling fan**

Model		SK2				SK3			SK4			SK5		SK6	
		401	402	403	404	401	402	403	401	402	403	401	402	401	402
Air flow	m <sup>3</sup> /hour	65		70		150			200			250		250	

## 1.2.4 Commander SK 575V size 3 to 6 units

### Key:

♦ Refer to Table 1-13 and Table 1-14 on page 10 for typical overload limits

\* Typical input current

The values of typical input current are given to aid calculations for power flow and power loss (Normal Duty rating).

The values of typical input current are stated for a balanced supply.

\*\* Maximum continuous input current

The values of maximum continuous input current are given to aid the selection of cables and fuses. These values are stated for the worse case condition with the unusual combination of a stiff supply with bad balance (Normal Duty rating). The value stated for the maximum continuous input current would only be seen in one of the input phases. The current in the other two phases would be significantly lower.

The values of maximum input current are stated with a 2% negative phase-sequence imbalance and rated at the maximum supply fault current given in the following tables.

\*\*\*\* Resistor tolerance ±10%

^ Semi-conductor fuse in series with HRC fuse or circuit breaker

^^ The minimum resistance value specified is for a stand-alone drive only. If the drive is part of a common DC bus system a different value must be used. Contact the supplier of the drive for more information

**Table 1-29 Size 3 ratings**

Model	SK3						
	501	502	503	504	505	506	507
AC supply voltage and frequency	3 phase 500 to 575Vac ±10% 48 to 65Hz						
Input displacement factor (cos ∅)	>0.97						
<b>Normal Duty</b>							
Nominal motor power at 575V (kW)	3.0	4.0	5.5	7.5	11	15	18.5
Nominal motor power at 575V (hp)	3.0	5.0	7.5	10	15	20	25
100% RMS output current (A)	5.4	6.1	8.4	11	16	22	27
<b>Heavy Duty</b>							
Nominal motor power at 575V (kW)	2.2	3.0	4.0	5.5	7.5	11	15
Nominal motor power at 575V (hp)	2.0	3.0	5.0	7.5	10	15	20
100% RMS output current (A)	4.1	5.4	6.1	9.5	12	18	22
Peak current (A) ♦	6.1	8.1	9.1	14.2	18	27	33
Typical full load input current (A) *	5.0	6.0	7.8	9.9	13.8	18.2	22.2
Maximum continuous input current (A) **	6.7	8.2	11.1	14.4	18.1	22.2	26.0
Typical inrush current (A)	18						
Maximum supply fault current (kA)	100						
Weight (kg)	15						
Weight (lb)	33.1						

**Table 1-30 Size 4 to 6 ratings**

Model	SK4				SK5		SK6	
	603	604	605	606	601	602	601	602
AC supply voltage and frequency	3 phase 500 to 575Vac ±10% 48 to 65Hz							
Input displacement factor (cos Ø)	>0.97							
<b>Normal Duty</b>								
Nominal motor power at 575V (kW)	22	30	37	45	55	75	90	110
Nominal motor power at 575V (hp)	30	40	50	60	75	100	125	150
100% RMS output current (A)	36	43	52	62	84	99	125	144
<b>Heavy Duty</b>								
Nominal motor power at 575V (kW)	18.5	22	30	37	45	55	75	90
Nominal motor power at 575V (hp)	25	30	40	50	60	75	100	125
100% RMS output current (A)	27	36	43	52	63	85	100	125
Peak current (A) ♦	40.5	54	64.5	78	93	126	128	160
Typical full load input current (A) *	32.9	39	46.2	55.2	75.5	89.1	128	144
Maximum continuous input current (A) **	35.1	41	47.9	56.9	82.6	94.8	138	156
Typical inrush current (A)	35				70			
Maximum supply fault current (kA)	100							
Weight (kg)	30				55		75	
Weight (lb)	66.1				121.3		165.3	

The power ratings above for model size 4 and larger are for the 690V drives when used on a 500V to 575V supply.

**Table 1-31 Size 3 fuses**

Model		SK3						
		501	502	503	504	505	506	507
Recommended input supply fuse (A)	IEC gG	8	10	12	16	20	25	32
	Class CC	10	10	15	15	20	25	
	Class J							30

**Table 1-32 Size 3 cables**

Model		SK3						
		501	502	503	504	505	506	507
Control cable	mm <sup>2</sup>	≥0.5						
	AWG	20						
Recommended input cable	mm <sup>2</sup>	1.0	1.0	1.5	2.5	4.0	4.0	6.0
	AWG	16	16	14	14	12	10	8
Recommended motor cable	mm <sup>2</sup>	1.0	1.0	1.0	1.5	2.5	4.0	6.0
	AWG	18	16	14	14	14	10	8
Recommended brake resistor	mm <sup>2</sup>	1.0	1.0	1.0	1.5	2.5	4.0	6.0
	AWG	18	16	14	14	14	10	8

**Table 1-33 Braking resistor (minimum resistance values and peak power rating for the braking resistor at 40°C)**

Model	SK3						
	501	502	503	504	505	506	507
Minimum braking resistor value (Ω)****	18						
Resistor peak power rating (kW)	50.7						
Average power for 60s (kW)	4.4	6.0	8.0	9.6	13.1	19.3	22.5

**Table 1-34 Cooling fan**

Model		SK3						
		501	502	503	504	505	506	507
Air flow	m <sup>3</sup> /hour	250						

**NOTE**

Refer to section 1.2.5 for the fuse and cable information for the 575V units (same as 690V units).

## 1.2.5 Commander SK 690V size 4 to 6 units

### Key:

◆ Refer to Table 1-13 and Table 1-14 on page 10 for typical overload limits

\* Typical input current

The values of typical input current are given to aid calculations for power flow and power loss (Normal Duty rating).

The values of typical input current are stated for a balanced supply.

\*\* Maximum continuous input current

The values of maximum continuous input current are given to aid the selection of cables and fuses. These values are stated for the worse case condition with the unusual combination of a stiff supply with bad balance (Normal Duty rating). The value stated for the maximum continuous input current would only be seen in one of the input phases. The current in the other two phases would be significantly lower.

The values of maximum input current are stated with a 2% negative phase-sequence imbalance and rated at the maximum supply fault current given in the following tables.

\*\*\*\* Resistor tolerance  $\pm 10\%$

^ Semi-conductor fuse in series with HRC fuse or circuit breaker

^^ The minimum resistance value specified is for a stand-alone drive only. If the drive is part of a common DC bus system a different value must be used. Contact the supplier of the drive for more information

**Table 1-35 Size 4 ratings**

Model	SK4					
	601	602	603	604	605	606
AC supply voltage and frequency	3 phase 500 to 690Vac $\pm 10\%$ 48 to 65Hz					
Input displacement factor (cos $\phi$ )	>0.97					
<b>Normal Duty</b>						
Nominal motor power at 690V (kW)	18.5	22	30	37	45	55
Nominal motor power at 690V (hp)	25	30	40	50	60	75
100% RMS output current (A)	22	27	36	43	52	62
<b>Heavy Duty</b>						
Nominal motor power at 690V(kW)	15	18.5	22	30	37	45
Nominal motor power at 690V (hp)	20	25	30	40	50	60
100% RMS output current (A)	19	22	27	36	43	52
Peak current (A) ◆	27	33	40.5	54	64.5	78
Typical full load input current (A) *	23	26.1	32.9	39	46.2	55.2
Maximum continuous input current (A) **	26.5	28.8	35.1	41	47.9	56.9
Typical inrush current (A)	35					
Maximum supply fault current (kA)	100					
Weight (kg)	30					
Weight (lb)	66.1					

**Table 1-36 Size 5 and 6 ratings**

Model	SK5		SK6	
	601	602	601	602
AC supply voltage and frequency	3 phase 500 to 690Vac $\pm 10\%$ 48 to 65Hz			
Input displacement factor (cos $\phi$ )	>0.97			
<b>Normal Duty</b>				
Nominal motor power at 690V(kW)	75	90	110	132
Nominal motor power at 690V (hp)	100	125	150	175
100% RMS output current (A)	84	99	125	144
<b>Heavy Duty</b>				
Nominal motor power at 690V (kW)	55	75	90	110
Nominal motor power at 690V (hp)	75	100	125	150
100% RMS output current (A)	63	85	100	125
Peak current (A) ◆	93	126	128	160
Typical full load input current (A) *	75.5	89.1	128	144
Maximum continuous input current (A) **	82.6	94.8	138	156
Typical inrush current (A)	70			
Maximum supply fault current (kA)	100			
Weight (kg)	55		75	
Weight (lb)	121.3		165.3	

**Table 1-37 Size 4 fuses**

Model		SK4											
		601	602	603	604	605	606	601	602	603	604	605	606
		Option 1					Option 2 <sup>^</sup>						
Recommended input supply fuse (A)	IEC gR	63					80						
	Ferraz HSJ	60											
	IEC gG UL class J						32	40	50	50	63	63	
	IEC class aR						125	125	125	125	125	125	

**Table 1-38 Size 5 and 6 fuses**

Model		SK5				SK6			
		601	602	601	602	601	602	601	602
		Option 1		Option 2 <sup>^</sup>		Option 1		Option 2 <sup>^</sup>	
Recommended input supply fuse (A)	IEC gR	125	125			200			
	Ferraz HSJ	100	100						
	IEC gG UL class J			90	125			200	
	IEC class aR			160	160				

**Table 1-39 Size 4 to 6 cables**

Model		SK4						SK5		SK6	
		601	602	603	604	605	606	601	602	601	602
Control cable	mm <sup>2</sup>	≥0.5						≥0.5			
	AWG	20						20			
Recommended input cable	mm <sup>2</sup>	4	6	10	16	16	25	35	50	2 x 50	2 x 50
	AWG	10	8	8	6	6	4	2	1	2 x 1	2 x 1
Recommended motor cable	mm <sup>2</sup>	4	6	10	16	16	25	35	50	2 x 50	2 x 50
	AWG	10	8	8	6	6	4	2	1	2 x 1	2 x 1
Recommended brake resistor	mm <sup>2</sup>	4	6	10	16	16	25	35	50	2 x 50	2 x 50
	AWG	10	8	8	6	6	4	2	1	2 x 1	2 x 1

**Table 1-40 Braking resistor (minimum resistance values and peak power rating for the braking resistor at 40°C)**

Model		SK4 <sup>^^</sup>						SK5 <sup>^^</sup>		SK6	
		601	602	603	604	605	606	601	602	601	602
Minimum braking resistor value (Ω) <sup>****</sup>		13						10		10	
Resistor peak power rating (kW)		95.0						125.4		125.4	
Average power for 60s (kW)		19.3	22.5	27.8	33.0	45.0	55.5	67.5	82.5	112.5	125.4

**Table 1-41 Cooling fan**

Model		SK4						SK5		SK6	
		601	602	603	604	605	606	601	602	601	602
Air flow	m <sup>3</sup> /hour	200						250		250	

## 2 Derating curves and losses

The derating curves are based on the results of heatruns that are carried out to measure temperatures of various components and at various key points within the drive at different switching frequencies, different loads and different ambient temperatures. The key components/points are:

- Heatsink
- Bridge rectifier
- IGBTs
- DC bus capacitors
- Various electrolytic capacitors
- Various resistors
- Various semiconductor components

It is not always the heatsink temperature that is the limiting factor for the de-rating curves.

At 3 and 6kHz, the limiting factor tends to be the capacitor temperatures. Operating outside the derating curves will cause some of the capacitors within the drive to run outside of their maximum operating temperature and this could lead to the drives design lifetime being reduced.

At 12 and 18kHz (18kHz where applicable) the limiting factor tends to be the heatsink temperatures. Operating outside the de-rating curves will cause the heatsink temperature to increase and may cause the drive to trip on O.ht2.

If the auto-switching frequency change is enabled (Pr 5.35 = 0 [by default]), the drive will automatically decrease the switching frequency when the heatsink temperature rises above pre-determined levels to reduce the heatsink temperature. When the drive switches down the switching frequency, the drives display will flash 'hot'.

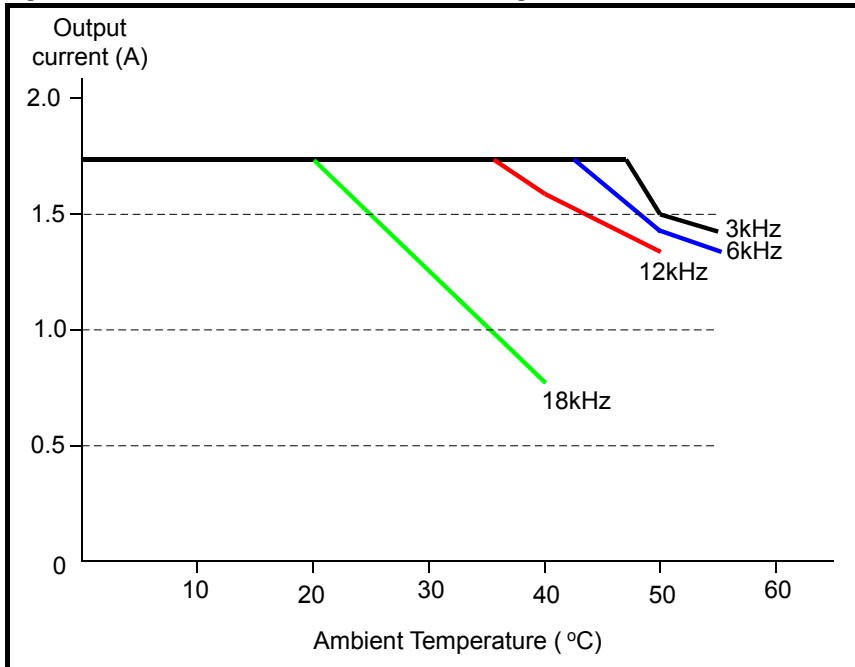
### NOTE

It is important that these de-rating curves are observed.

## 2.1 Size A

### 2.1.1 Derating curves

Figure 2-1 Commander SK Size A 0.25kW derating curve



### NOTE

The derating curves and losses for the 110V size A and B are the same as the equivalent 200V drive.

Figure 2-2 Commander SK Size A 0.37kW derating curve

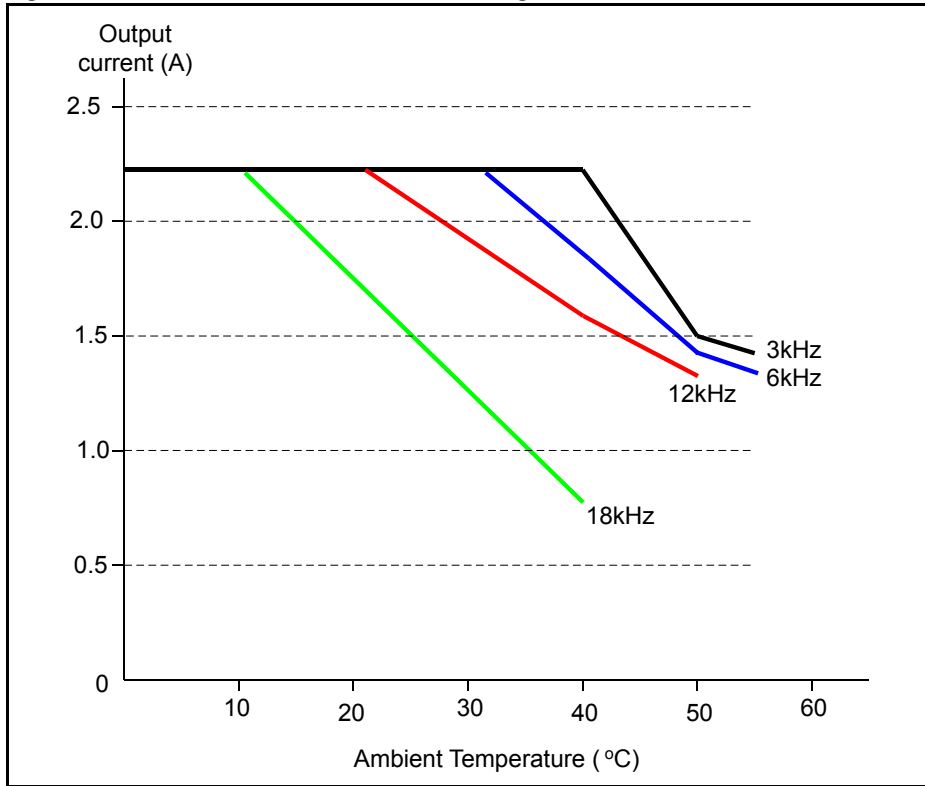
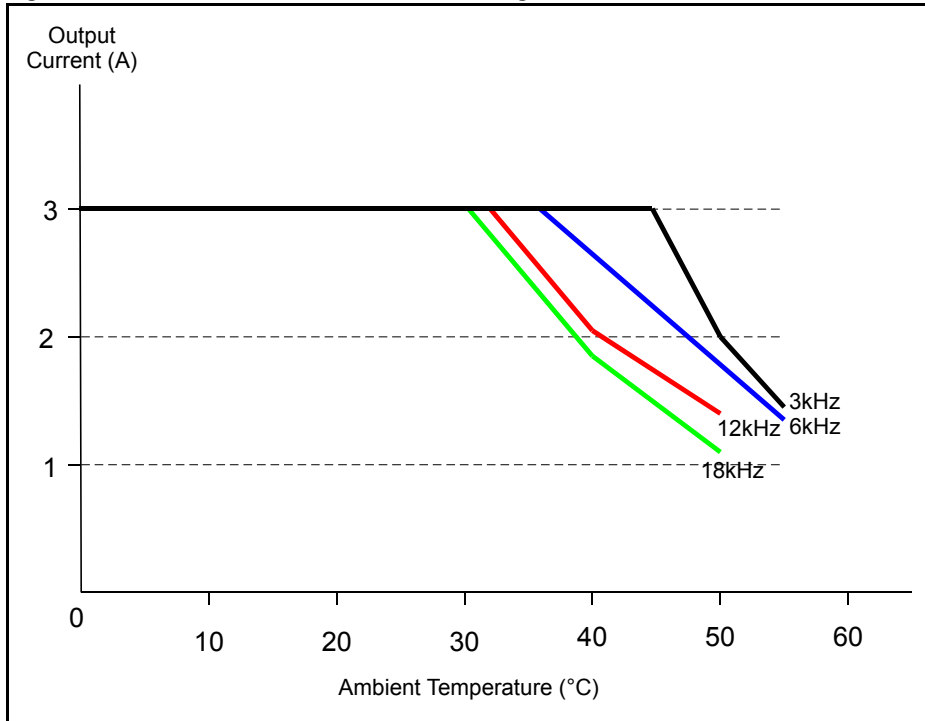
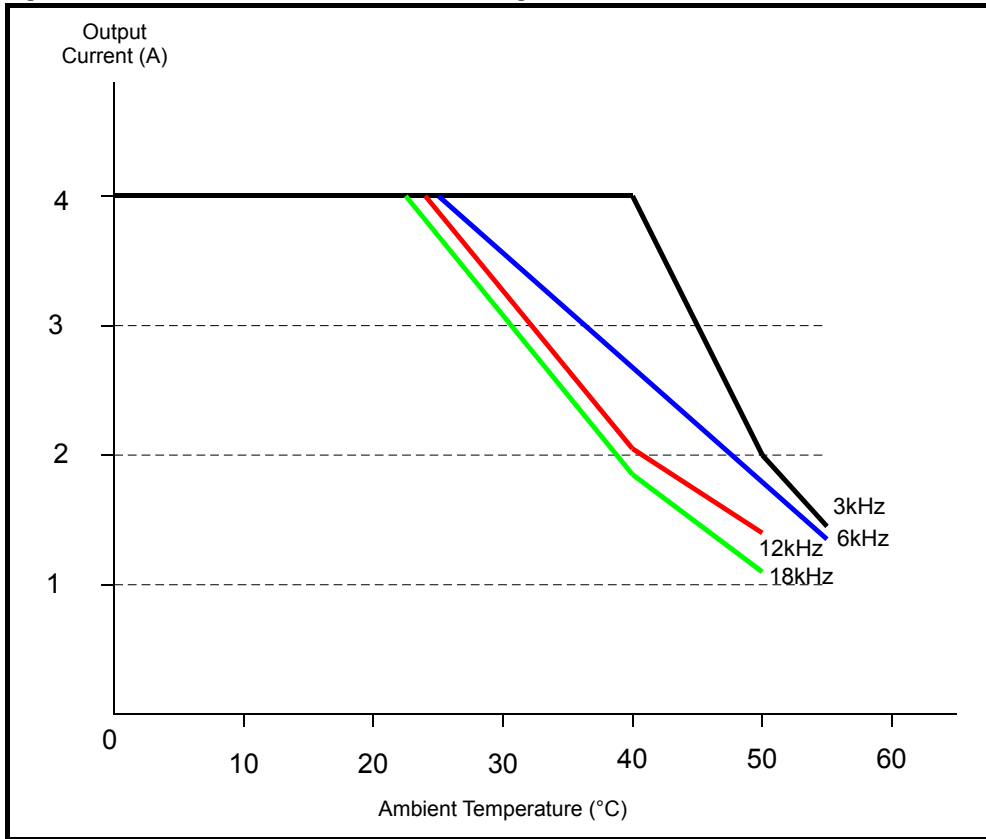


Figure 2-3 Commander SK Size A 0.55kW derating curve



**Figure 2-4 Commander SK Size A 0.75kW derating curve**



### 2.1.2 Drive losses

The following tables indicate the total drive losses at the de-rating curve points.

**Table 2-1 Commander SK size A 0.25kW losses**

Ambient Temperature (°C)	Loss (W)			
	3kHz	6kHz	12kHz	18kHz
30	30	32	36	35
40	30	32	38	30
50	29	31	34	
55	29	30		

**Table 2-2 Commander SK size A 0.37kW losses**

Ambient Temperature (°C)	Loss (W)			
	3kHz	6kHz	12kHz	18kHz
30	34	36	38	35
40	34	33	38	30
50	29	31	34	
55	29	30		

**Table 2-3 Commander SK size A 0.55kW losses**

Ambient Temperature (°C)	Loss (W)			
	3kHz	6kHz	12kHz	18kHz
30	42	46	53	61
40	42	43	44	47
50	35	36	37	38
55	31	33		



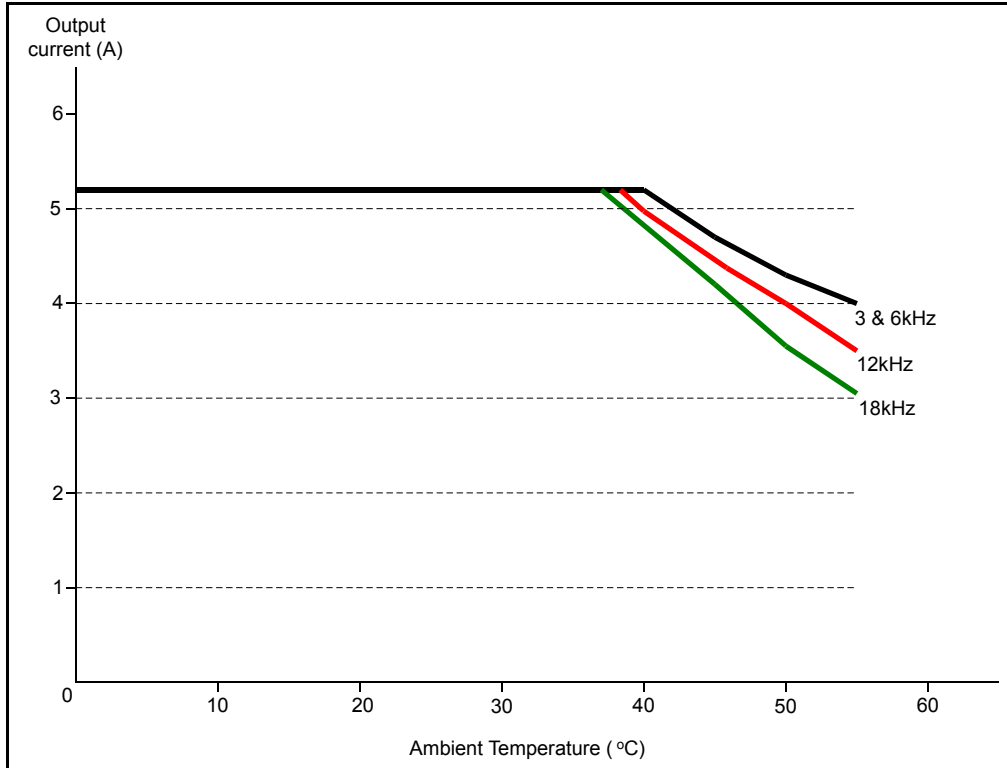
**Table 2-4 Commander SK size A 0.75kW losses**

Ambient Temperature (°C)	Loss (W)			
	3kHz	6kHz	12kHz	18kHz
30	48	50	59	62
40	48	43	44	47
50	35	36	37	38
55	31	33		

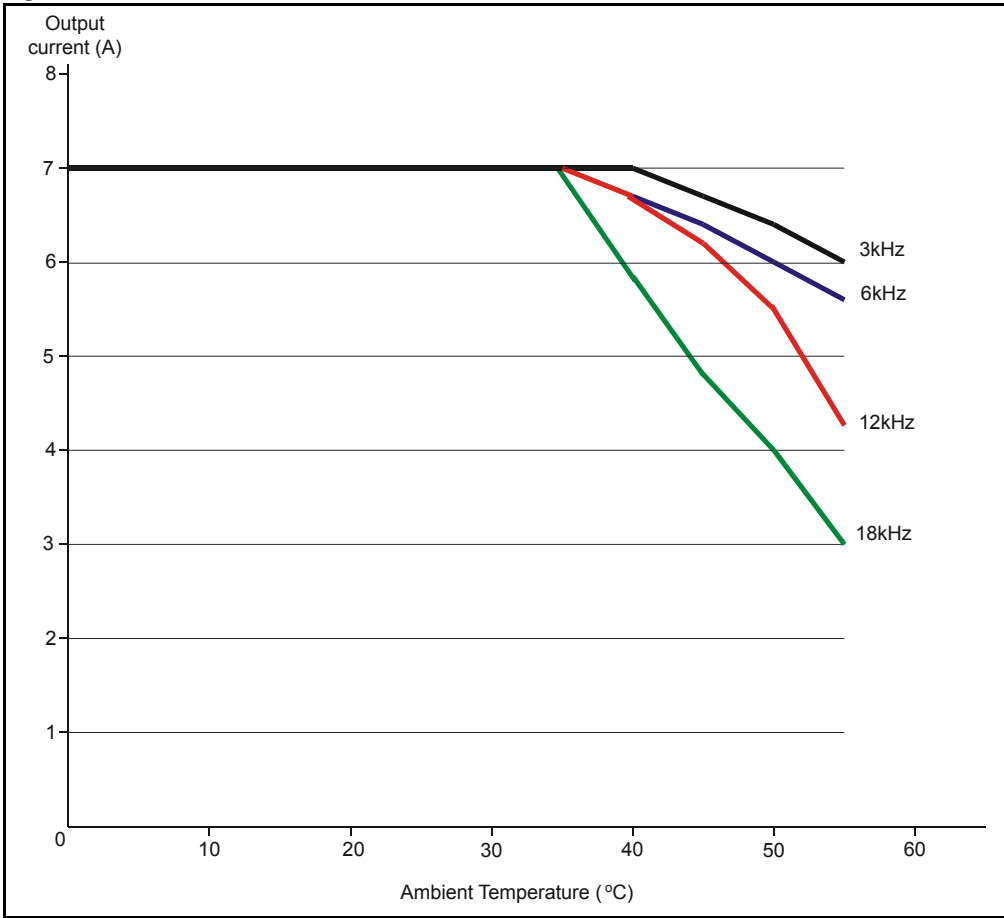
## 2.2 Size B

### 2.2.1 Derating curves

**Figure 2-5 Commander SK Size B, 200V, 1.1kW**

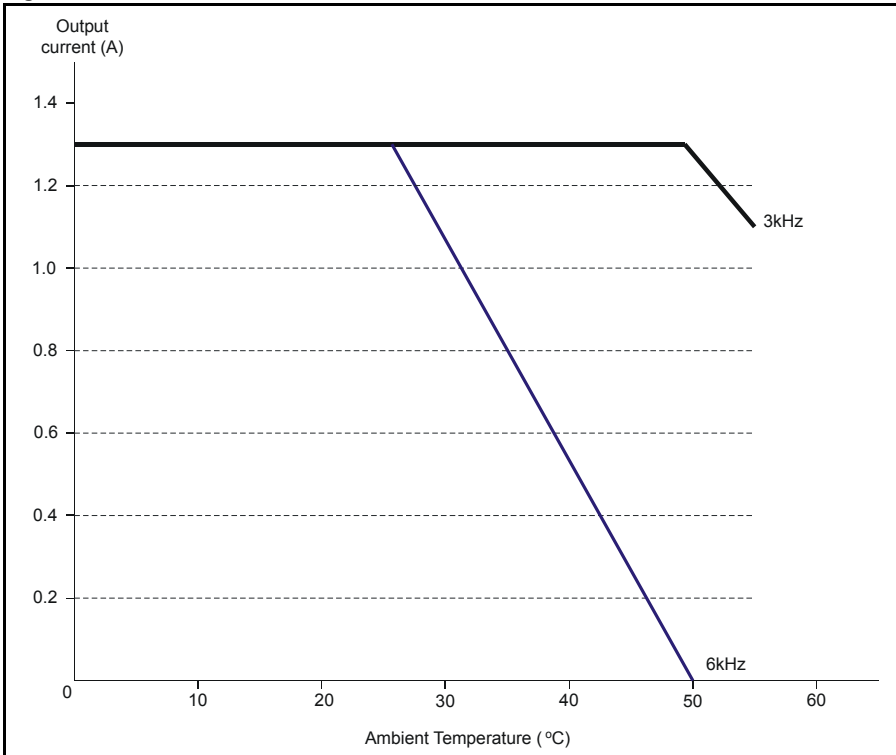


**Figure 2-6 Commander SK Size B, 200V, 1.5kW**

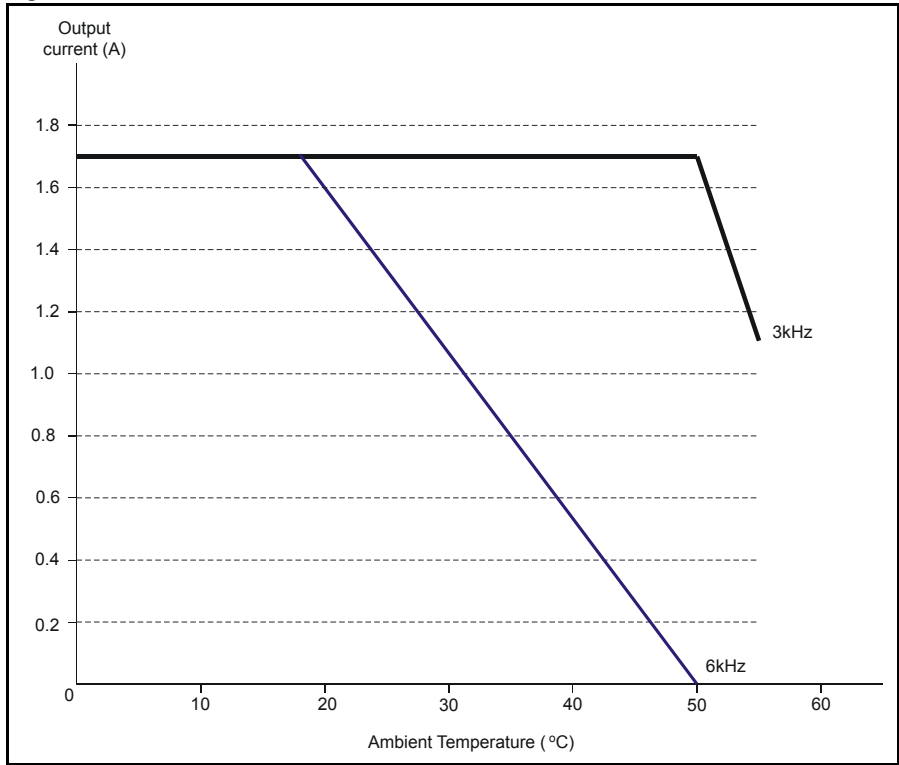


With the 0.37, 0.55 & 0.75kW drives, no 12kHz derating information is shown on the graphs. This is because the losses at 12kHz is too great to run the drive continuously. Depending on the duty cycle etc. it is still possible to run the drive at 12kHz but if the heatsink gets too hot, the drive will automatically switch down the switching frequency to 6kHz. When the drive does this, the display will flash 'hot' to indicate that the drive has automatically switched down the switching frequency.

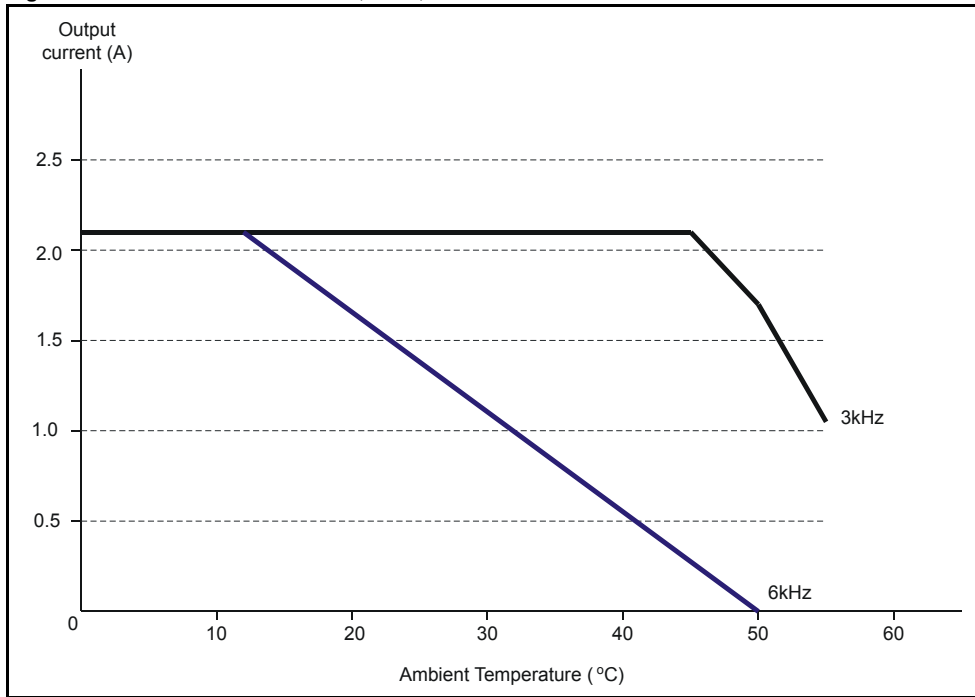
**Figure 2-7 Commander SK Size B, 400V, 0.37kW**



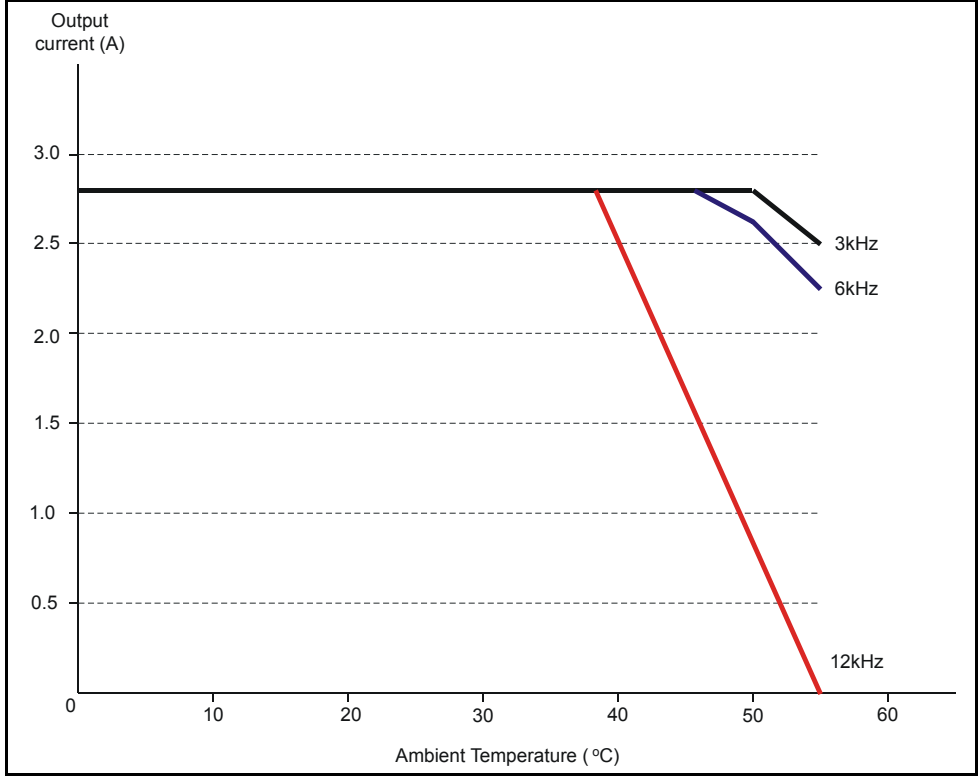
**Figure 2-8 Commander SK Size B, 400V, 0.55kW**



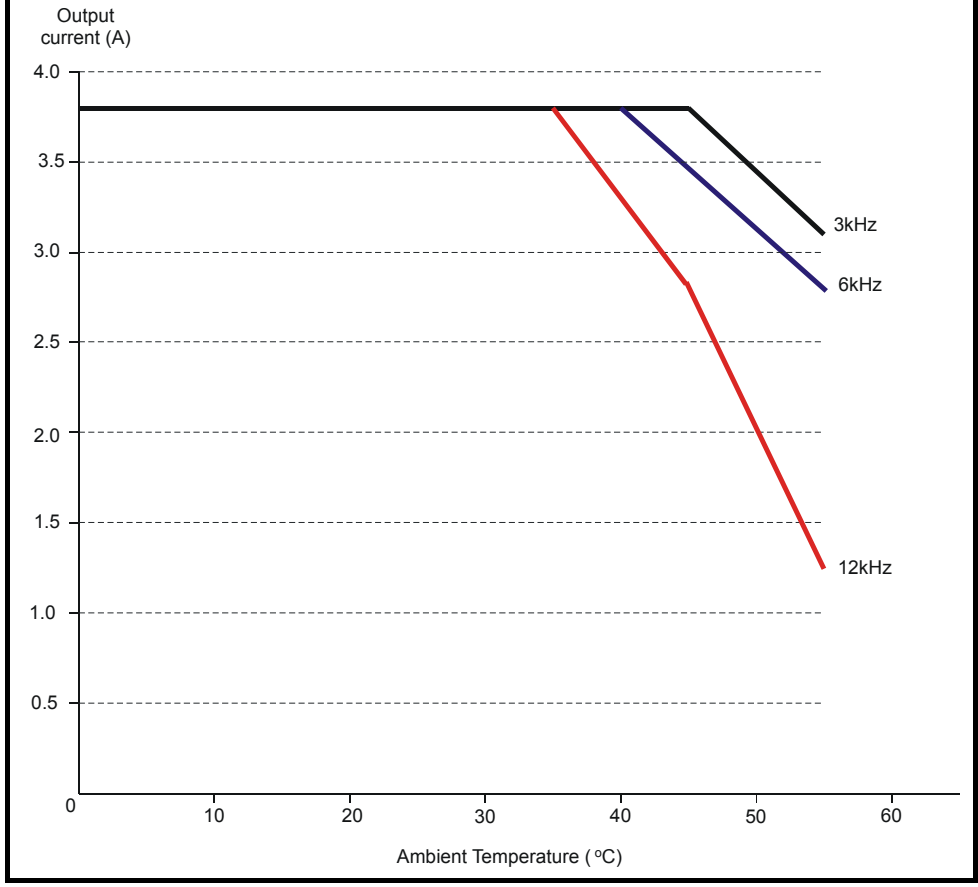
**Figure 2-9 Commander SK Size B, 400V, 0.75kW**



**Figure 2-10 Commander SK Size B, 400V, 1.1kW**



**Figure 2-11 Commander SK Size B, 400V, 1.5kW**



## 2.2.2 Drive losses

The following tables indicate the total drive losses at the de-rating curve points.

**Table 2-5 Commander SK Size B, 200V, 1.1kW**

Ambient Temperature (°C)	Loss (W)			
	3kHz	6kHz	12kHz	18kHz
30	58	63	73	84
40	58	63	70	78
50	51	55	60	62
55	48	51	54	57

**Table 2-6 Commander SK Size B, 200V, 1.5kW**

Ambient Temperature (°C)	Loss (W)			
	3kHz	6kHz	12kHz	18kHz
30	72	79	85	92
40	72	76	82	80
50	66	69	71	59
55	63	65	57	50

**Table 2-7 Commander SK Size B, 400V, 0.37kW**

Ambient Temperature (°C)	Loss (W)		
	3kHz	6kHz	12kHz
30	24	27	
40	24	21	
50	24		
55	22		

**Table 2-8 Commander SK Size B, 400V, 0.55kW**

Ambient Temperature (°C)	Loss (W)		
	3kHz	6kHz	12kHz
30	27	26	
40	27	21	
50	27		
55	22		

**Table 2-9 Commander SK Size B, 400V, 0.75kW**

Ambient Temperature (°C)	Loss (W)		
	3kHz	6kHz	12kHz
30	31	27	
40	31	21	
50	26		
55	22		

**Table 2-10 Commander SK Size B, 400V, 1.1kW**

Ambient Temperature (°C)	Loss (W)		
	3kHz	6kHz	12kHz
30	43	51	68
40	43	51	62
50	43	49	35
55	40	44	

**Table 2-11 Commander SK Size B, 400V, 1.5kW**

Ambient Temperature (°C)	Loss (W)		
	3kHz	6kHz	12kHz
30	53	65	87
40	53	65	76
50	49	55	55
55	46	51	45

**NOTE**

The drive losses for the 110V drives will be the same as the equivalent 200V drives.

## 2.3 Size C

### 2.3.1 Derating curves

Figure 2-12 Commander SK Size C, 200V, 2.2kW

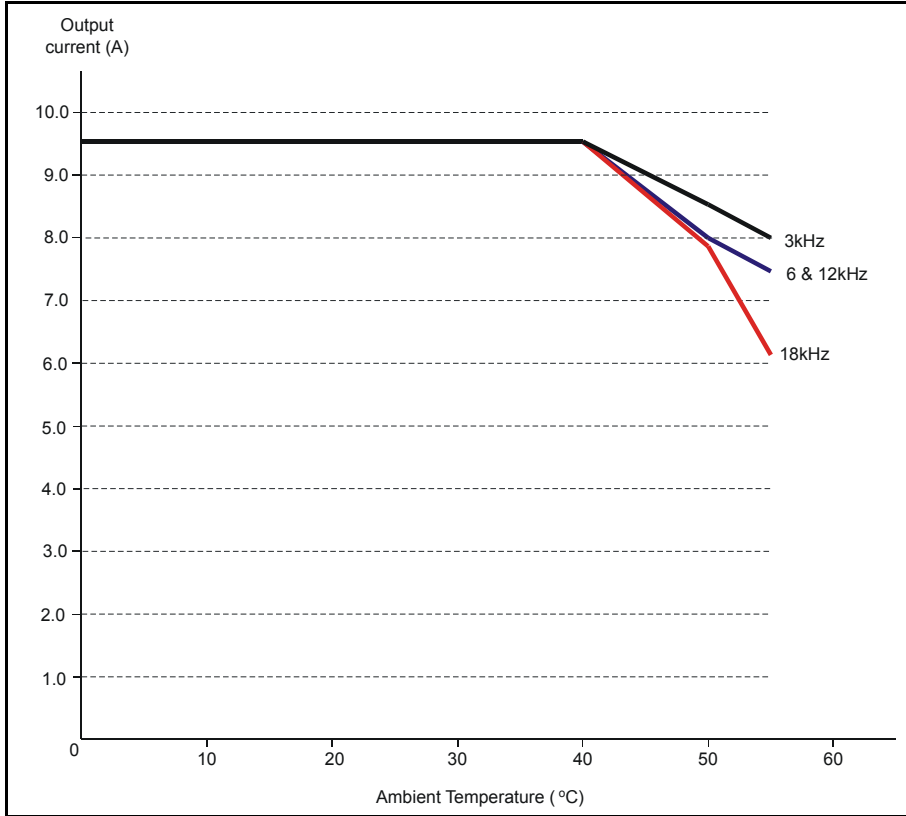
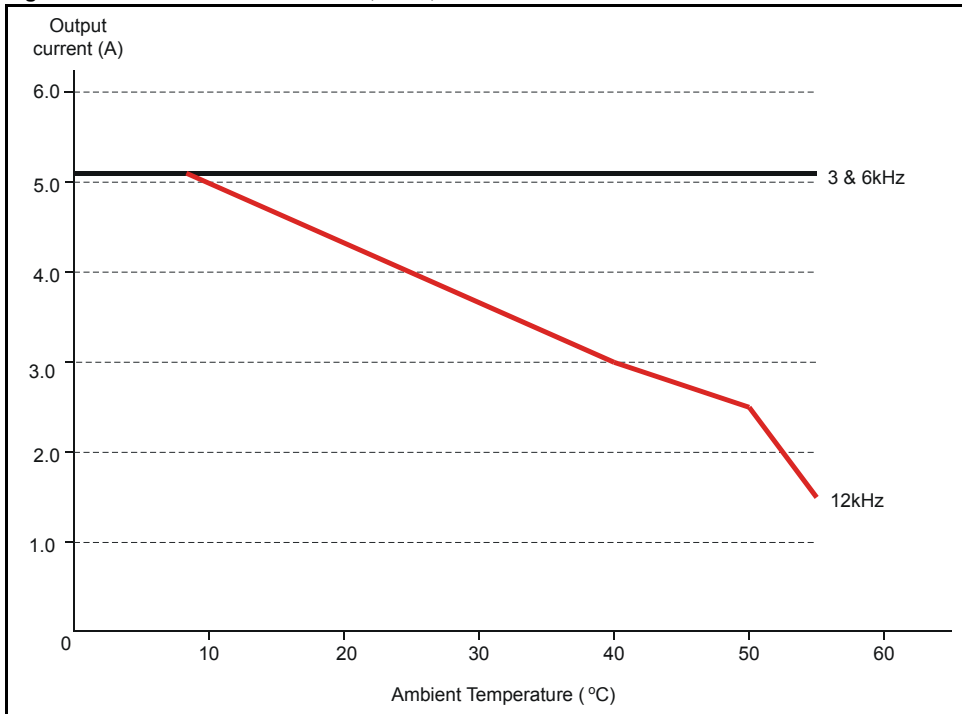
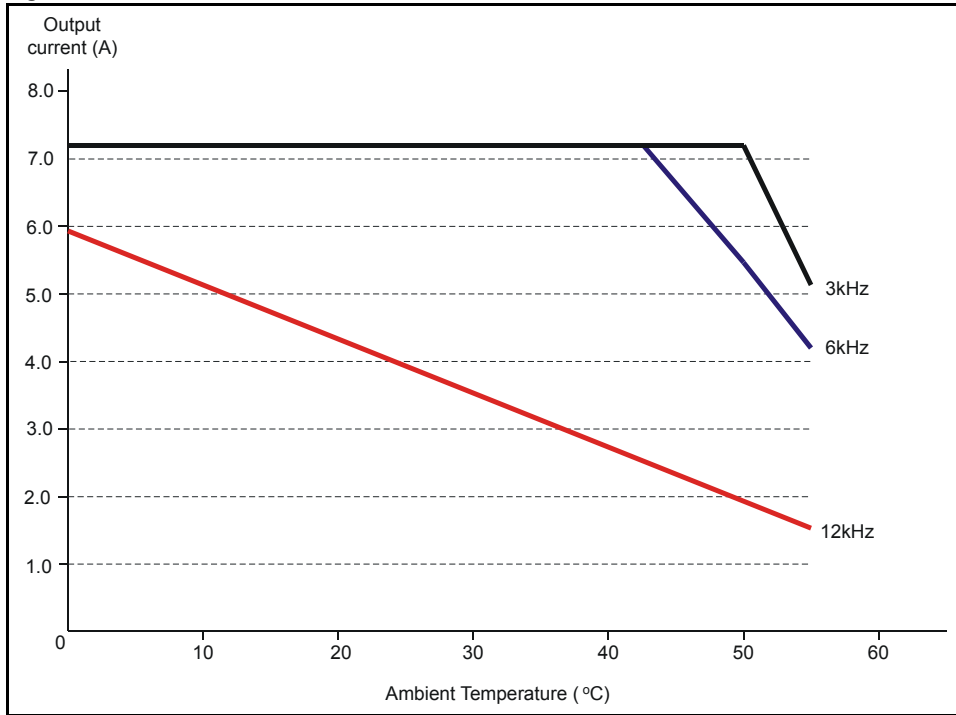


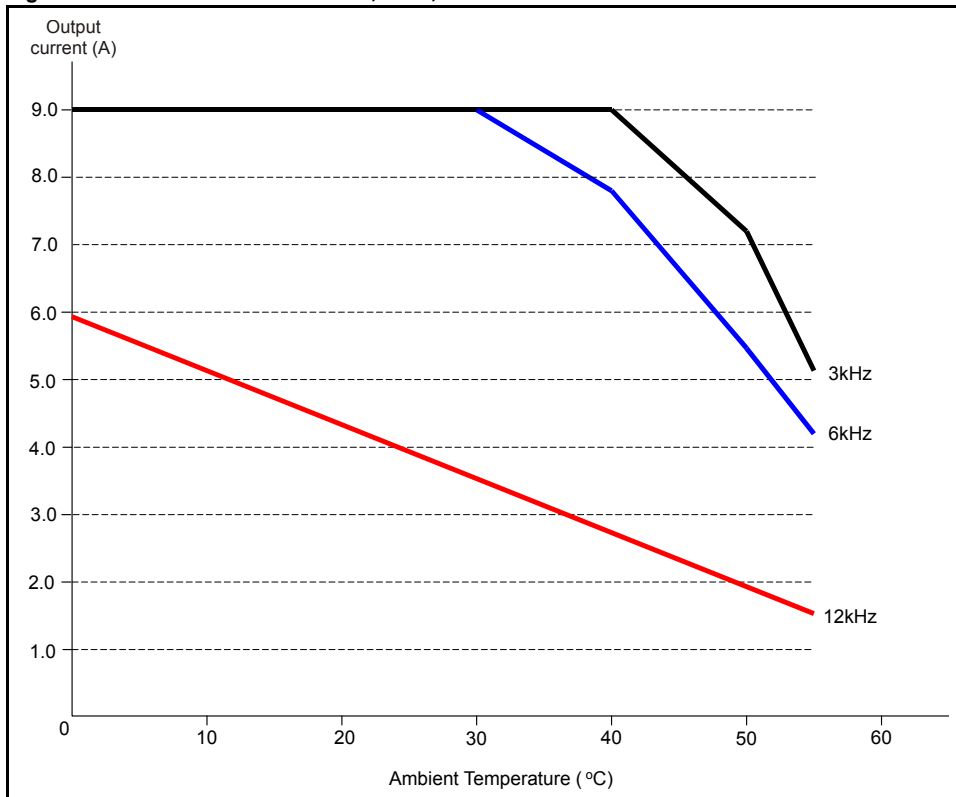
Figure 2-13 Commander SK Size C, 400V, 2.2kW



**Figure 2-14 Commander SK Size C, 400V, 3.0kW**



**Figure 2-15 Commander SK Size C, 400V, 4.0kW**



### 2.3.2 Drive losses

Table 2-12 Commander SK Size C, 200V, 2.2kW

Ambient Temperature (°C)	Loss (W)			
	3kHz	6kHz	12kHz	18kHz
30	93	107	133	158
40	93	107	133	158
50	84	93	115	133
55	80	88	109	111

Table 2-13 Commander SK Size C, 400V, 2.2kW

Ambient Temperature (°C)	Loss (W)		
	3kHz	6kHz	12kHz
30	78	108	118
40	78	108	101
50	78	108	88
55	78	108	60

Table 2-14 Commander SK Size C, 400V, 3.0kW

Ambient Temperature (°C)	Loss (W)		
	3kHz	6kHz	12kHz
30	91	117	93
40	91	117	78
50	91	94	62
55	70	77	47

Table 2-15 Commander SK Size C, 400V, 4.0kW

Ambient Temperature (°C)	Loss (W)		
	3kHz	6kHz	12kHz
30	116	149	99
40	116	132	84
50	96	100	69
55	75	83	54

## 2.4 Size D

### 2.4.1 Derating curves

Figure 2-16 Commander SK Size D, 200V, 3.0kW

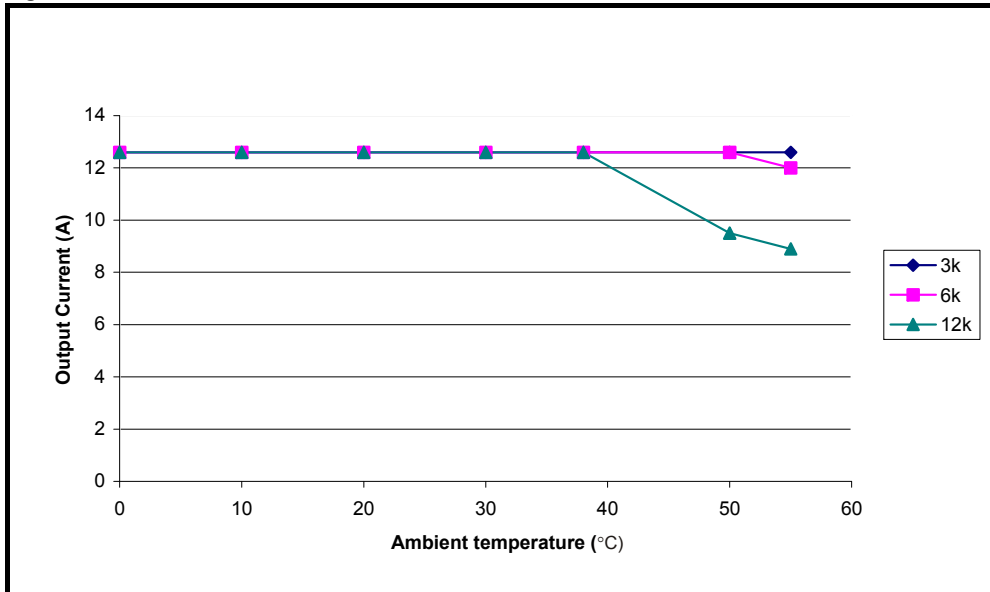




Figure 2-17 Commander SK Size D, 200V, 4.0kW

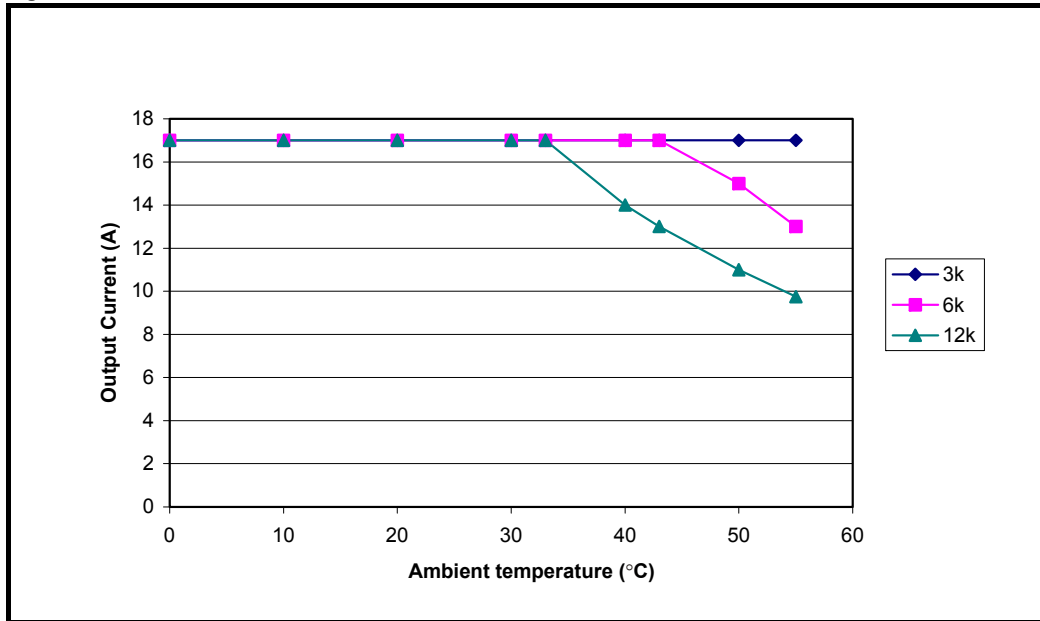
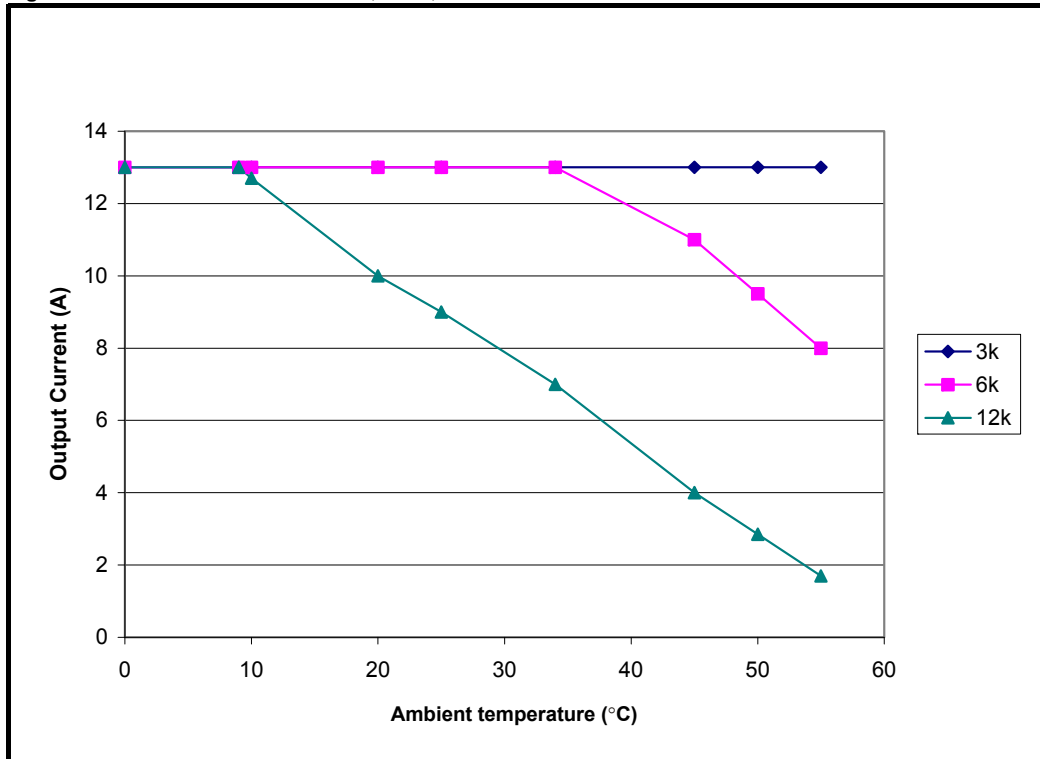
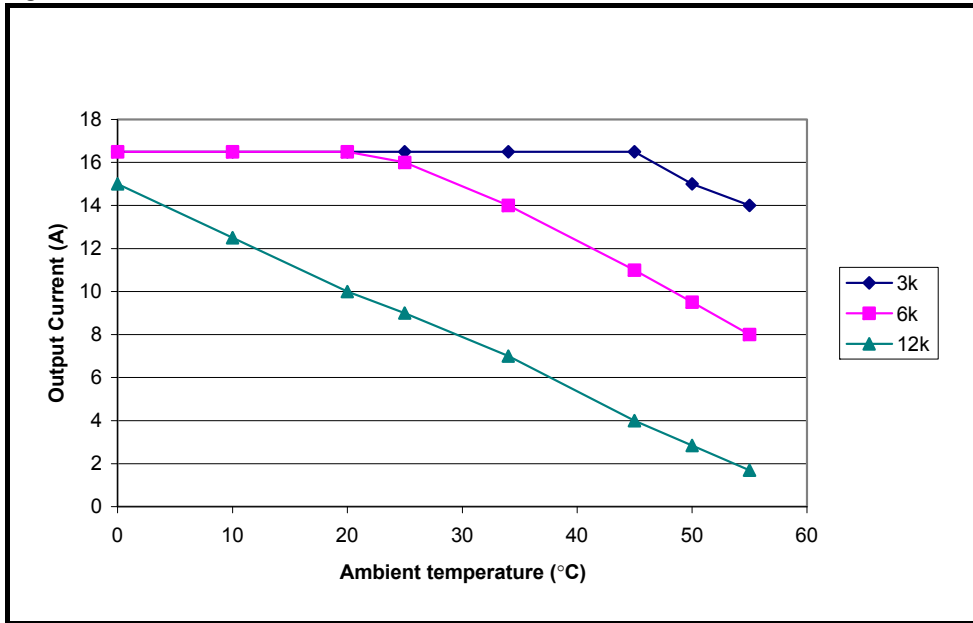


Figure 2-18 Commander SK Size D, 400V, 5.5kW



**Figure 2-19 Commander SK Size D, 400V, 7.5kW**



### 2.4.2 Drive losses

**Table 2-16 Commander SK Size D, 200V, 3.0kW**

Ambient Temperature (°C)	Loss (W)		
	3kHz	6kHz	12kHz
30	130	151	193
40	130	151	181
50	130	151	150
55	130	142	139

**Table 2-17 Commander SK Size D, 200V, 4.0kW**

Ambient Temperature (°C)	Loss (W)		
	3kHz	6kHz	12kHz
30	179	208	264
40	179	208	209
50	179	185	170
55	179	154	151

**Table 2-18 Commander SK Size D, 400V, 5.5kW**

Ambient Temperature (°C)	Loss (W)		
	3kHz	6kHz	12kHz
30	174	226	216
40	174	210	165
50	174	175	120
55	174	151	90

**Table 2-19 Commander SK Size D, 400V, 7.5kW**

Ambient Temperature (°C)	Loss (W)		
	3kHz	6kHz	12kHz
30	220	257	226
40	220	217	165
50	198	175	119
55	187	157	85

**NOTE**

These loss figures show the amount of losses at the maximum available output current for each switching frequency and temperature.

## 2.5 Size 2

### 2.5.1 Power and current ratings (derating for switching frequency and temperature)

Table 2-20 Maximum permissible continuous output current @ 40°C (104°F) ambient for wall mounted drives

Model	Normal Duty					Heavy Duty				
	Nominal rating		Maximum continuous output current (A) @ each switching frequency			Nominal rating		Maximum continuous output current (A) @ each switching frequency		
	kW	hp	3kHz	6kHz	12kHz	kW	hp	3kHz	6kHz	12kHz
SK2201	4.0	5.0	15.5			3.0	3.0	12.6		
SK2202	5.5	7.5	22.0			4.0	5.0	17.0		
SK2203	7.5	10	28.0		24.8	5.5	7.5	25.0	24.2	19.6
SK2401	7.5	10	15.3		12.7	5.5	10	13.0		9.6
SK2402	11	15	21.0	19.5	12.7	7.5	10	16.5	14.9	9.6
SK2403	15	20	29.0	23.2	15.0	11	20	25.0	19.9	12.8
SK2404*	15	20	29.0	26.6	16.5	15	20	29.0	20.5	12.1

Table 2-21 Maximum permissible continuous output current @ 40°C (104°F) ambient with IP54 insert and standard or IP54 fan installed

Model	Normal Duty					Heavy Duty				
	Nominal rating		Maximum continuous output current (A) @ each switching frequency			Nominal rating		Maximum continuous output current (A) @ each switching frequency		
	kW	hp	3kHz	6kHz	12kHz	kW	hp	3kHz	6kHz	12kHz
SK2201	4.0	5.0	15.5			3.0	3.0	12.6		
SK2202	5.5	7.5	22.0		18.0	4.0	5.0	17.0		
SK2203	7.5	10	24.5	22.0	17.9	5.5	7.5	24.2	21.8	17.7
SK2401	7.5	10	15.3		10.1	5.5	10	13.0		9.4
SK2402	11	15	20.1	15.6	10.1	7.5	10	16.5	14.9	9.3
SK2403	15	20	21.7	16.4	10.2	11	20	21.6	16.4	10.2
SK2404*	15	20	20.1	14.0	7.3	15	20	20.1	14.0	7.3

\* See section \*\*\* SK2404 Power and current ratings on page 12.

Table 2-22 Maximum permissible continuous output current @ 50°C (122°F) ambient for wall mounted drives

Model	Normal Duty					Heavy Duty				
	Nominal rating		Maximum continuous output current (A) @ each switching frequency			Nominal rating		Maximum continuous output current (A) @ each switching frequency		
	kW	hp	3kHz	6kHz	12kHz	kW	hp	3kHz	6kHz	12kHz
SK2201	4.0	5.0	15.5		13.5	3.0	3.0	12.6		
SK2202	5.5	7.5	19.7	17.3	13.5	4.0	5.0	17.0		13.4
SK2203	7.5	10	19.5	17.2	13.4	5.5	7.5	19.2	17.0	13.3
SK2401	7.5	10	15.3	11.8	7.3	5.5	10	13.0	11.7	7.3
SK2402	11	15	15.7	11.8	7.3	7.5	10	15.5	11.7	7.3
SK2403	15	20	16.8	12.2	7.1	11	20	16.7	12.2	7.1
SK2404*	15	20	22.3	15.8	8.6	15	20	22.3	14.0	7.3

\* See section \*\*\* SK2404 Power and current ratings on page 12.

#### NOTE

For the definition of ambient temperature, see section 5.3.5 Enclosure design and drive ambient temperature on page 77.

## 2.5.2 Drive losses

**Table 2-23 Losses @ 40°C (104°F) ambient for wall mounted drives**

Model	Drive losses (W) taking into consideration any current derating for the given conditions									
	Normal Duty					Heavy Duty				
	Nominal rating		3kHz	6kHz	12kHz	Nominal rating		3kHz	6kHz	12kHz
	kW	hp				kW	hp			
SK2201	4.0	5.0	155	173	210	3.0	3.0	133	150	182
SK2202	5.5	7.5	210	234	282	4.0	5.0	170	190	229
SK2203	7.5	10	272	302	320	5.5	7.5	245	263	259
SK2401	7.5	10	186	234	283	5.5	10	164	206	229
SK2402	11	15	248	291	283	7.5	10	201	230	229
SK2403	15	20	313	320	315	11	20	272	279	279
SK2404	15	20	311	376		15	20	311	301	302

**NOTE**

For the definition of ambient temperature, see section 5.3.5 *Enclosure design and drive ambient temperature* on page 77.

**Table 2-24 Losses @ 40°C (104°F) ambient with IP54 insert and standard or IP54 fan installed**

Model	Drive losses (W) taking into consideration any current derating for the given conditions									
	Normal Duty					Heavy Duty				
	Nominal rating		3kHz	6kHz	12kHz	Nominal rating		3kHz	6kHz	12kHz
	kW	hp				kW	hp			
SK2201	4.0	5.0	155	173	210	3.0	3.0	133	150	182
SK2202	5.5	7.5	210	234	237	4.0	5.0	170	190	229
SK2203	7.5	10	237			5.5	7.5	237		
SK2401	7.5	10	186	234	237	5.5	10	164	206	226
SK2402	11	15	237			7.5	10	201	230	224
SK2403	15	20	237			11	20	237		
SK2404	15	20	225			15	20	225		

**Table 2-25 Losses @ 50°C (122°F) ambient for wall mounted drives**

Model	Drive losses (W) taking into consideration any current derating for the given conditions									
	Normal Duty					Heavy Duty				
	Nominal rating		3kHz	6kHz	12kHz	Nominal rating		3kHz	6kHz	12kHz
	kW	hp				kW	hp			
SK2201	4.0	5.0	155	173	190	3.0	3.0	133	150	182
SK2202	5.5	7.5	190			4.0	5.0	170	190	
SK2203	7.5	10	190			5.5	7.5	190		
SK2401	7.5	10	186	190		5.5	10	164	190	
SK2402	11	15	190			7.5	10	190		
SK2403	15	20	190			11	20	190		
SK2404	15	20	245			15	20	245		

## 2.6 Size 3

### 2.6.1 Power and current ratings (derating for switching frequency and temperature)

Table 2-26 Maximum permissible continuous output current @ 40°C (104°F) ambient for wall mounted drives

Model	Normal Duty					Heavy Duty				
	Nominal rating		Maximum continuous output current (A) @ each switching frequency			Nominal rating		Maximum continuous output current (A) @ each switching frequency		
	kW	hp	3kHz	6kHz	12kHz	kW	hp	3kHz	6kHz	12kHz
SK3201	11	15	42.0			7.5	10	31.0		
SK3202	15	20	54.0		48.5	11	15	42.0		41.3
SK3401	18.5	25	35.0		26.3	15	25	32.0		22.0
SK3402	22	30	43.0		28.6	18.5	30	40.0	38.3	24.5
SK3403	30	40	56.0	44.6	28.6	22	30	46.0	38.3	24.5
SK3501	3.0	3.0	5.4			2.2	2.0	4.1		
SK3502	4.0	5.0	6.1			3.0	3.0	5.4		
SK3503	5.5	7.5	8.4			4.0	5.0	6.1		
SK3504	7.5	10	11.0			5.5	7.5	9.5		
SK3505	11	15	16.0			7.5	10	12.0		
SK3506	15	20	22.0	18.2		11	15	18.0		
SK3507	18.5	25	27.0	21.6		15	20	22.0	18.4	

Table 2-27 Maximum permissible continuous output current @ 50°C (122°F) ambient for wall mounted drives

Model	Normal Duty					Heavy Duty				
	Nominal rating		Maximum continuous output current (A) @ each switching frequency			Nominal rating		Maximum continuous output current (A) @ each switching frequency		
	kW	hp	3kHz	6kHz	12kHz	kW	hp	3kHz	6kHz	12kHz
SK3201	11	15	42.0		38.2	7.5	10	31.0		
SK3202	15	20	54.0	52.8	38.2	11	15	42.0		37.2
SK3401	18.5	25	35.0	33.5	21.5	15	25	32.0	30.7	19.7
SK3402	22	30	43.0	34.2	21.0	18.5	30	40.0	34.1	20.7
SK3403	30	40	46.0	34.2	21.0	22	30	46.0	33.6	20.8
SK3501	3.0	3.0	5.4			2.2	2.0	4.1		
SK3502	4.0	5.0	6.1			3.0	3.0	5.4		
SK3503	5.5	7.5	8.4			4.0	5.0	6.1		
SK3504	7.5	10	11.0			5.5	7.5	9.5		
SK3505	11	15	16.0			7.5	10	12.0		
SK3506	15	20	22.0	17.8		11	15	18.0	16.8	
SK3507	18.5	25	24.6	17.8		15	20	22.0	16.7	

#### NOTE

For the definition of ambient temperature, see section 5.3.5 *Enclosure design and drive ambient temperature* on page 77.

## 2.6.2 Drive losses

**Table 2-28 Losses @ 40°C (104°F) ambient for wall mounted drives**

Model	Drive losses (W) taking into consideration any current derating for the given conditions									
	Normal Duty					Heavy Duty				
	Nominal rating		3kHz	6kHz	12kHz	Nominal rating		3kHz	6kHz	12kHz
	kW	hp				kW	hp			
SK3201	11	15	331	380	477	7.5	10	260	297	370
SK3202	15	20	431	492	551	11	15	349	398	486
SK3401	18.5	25	364	449	477	15	25	337	415	408
SK3402	22	30	437	540	514	18.5	30	411	485	452
SK3403	30	40	567	552	510	22	30	474	485	452
SK3501	3.0	3.0	127	168		2.2	2.0	112	148	
SK3502	4.0	5.0	135	180		3.0	3.0	127	168	
SK3503	5.5	7.5	163	218		4.0	5.0	135	180	
SK3504	7.5	10	197	263		5.5	7.5	178	237	
SK3505	11	15	267	354		7.5	10	212	281	
SK3506	15	20	362	475		11	15	300	396	
SK3507	18.5	25	448	477		15	20	365	406	

**NOTE**

For the definition of ambient temperature, see section 5.3.5 *Enclosure design and drive ambient temperature* on page 77.

**Table 2-29 Losses @ 50°C (122°F) ambient for wall mounted drives**

Model	Drive losses (W) taking into consideration any current derating for the given conditions									
	Normal Duty					Heavy Duty				
	Nominal rating		3kHz	6kHz	12kHz	Nominal rating		3kHz	6kHz	12kHz
	kW	hp				kW	hp			
SK3201	11	15	331	380	436	7.5	10	260	297	370
SK3202	15	20	431	480	439	11	15	349	398	439
SK3401	18.5	25	364	430	399	15	25	337	399	373
SK3402	22	30	437	435	399	18.5	30	411	435	396
SK3403	30	40	474	429	397	22	30	474	429	397
SK3501	3.0	3.0	127	168		2.2	2.0	112	148	
SK3502	4.0	5.0	135	180		3.0	3.0	127	168	
SK3503	5.5	7.5	163	218		4.0	5.0	135	180	
SK3504	7.5	10	197	263		5.5	7.5	178	237	
SK3505	11	15	267	354		7.5	10	212	281	
SK3506	15	20	362	390		11	15	300	372	
SK3507	18.5	25	405	390		15	20	365	369	

## 2.7 Size 4

### 2.7.1 Power and current ratings (derating for switching frequency and temperature)

Table 2-30 Maximum permissible continuous output current @ 40°C (104°F) ambient for wall mounted drives

Model	Normal Duty					Heavy Duty				
	Nominal rating		Maximum continuous output current (A) @ each switching frequency			Nominal rating		Maximum continuous output current (A) @ each switching frequency		
	kW	hp	3kHz	6kHz	12kHz	kW	hp	3kHz	6kHz	12kHz
SK4201	18.5	25	68.0			15	20	56.0		
SK4202	22	30	80.0			18.5	25	68.0		
SK4203	30	40	104			22	30	80.0		
SK4401	37	50	68.0			30	50	60.0	51.9	
SK4402	45	60	83.0	74.0		37	60	74.0	51.9	
SK4403	55	75	104	95.1		45	75	96.0	66.6	
SK4601	18.5	25	22.0			15	20	19.0		
SK4602	22	30	27.0			18.5	25	22.0		
SK4603	30	40	36.0			22	30	27.0		
SK4604	37	50	43.0	41.3		30	40	36.0		
SK4605	45	60	52.0	41.2		37	50	43.0	41.3	
SK4606	55	75	62.0	48.4		45	60	52.0	44.7	

Table 2-31 Maximum permissible continuous output current @ 50°C (122°F) ambient for wall mounted drives

Model	Normal Duty					Heavy Duty				
	Nominal rating		Maximum continuous output current (A) @ each switching frequency			Nominal rating		Maximum continuous output current (A) @ each switching frequency		
	kW	hp	3kHz	6kHz	12kHz	kW	hp	3kHz	6kHz	12kHz
SK4201	18.5	25	68.0			15	20	56.0		
SK4202	22	30	80.0			18.5	25	68.0		
SK4203	30	40	87.4			22	30	80.0		
SK4401	37	50	68.0	66.8		30	50	60.0	46.7	
SK4402	45	60	83.0	66.8		37	60	68.2	46.7	
SK4403	55	75	86.5	71.3		45	75	86.5	60.1	
SK4601	18.5	25	22.0			15	20	19.0		
SK4602	22	30	27.0			18.5	25	22.0		
SK4603	30	40	36.0	30.7		22	30	27.0		
SK4604	37	50	43.0	30.7		30	40	36.0	30.7	
SK4605	45	60	45.6	30.7		37	50	43.0	30.7	
SK4606	55	75	51.9	34.7		45	60	51.9	34.7	

**NOTE**

For the definition of ambient temperature, see section 5.3.5 *Enclosure design and drive ambient temperature* on page 77.

## 2.7.2 Drive losses

Table 2-32 Losses @ 40°C (104°F) ambient for wall mounted drives

Model	Drive losses (W) taking into consideration any current derating for the given conditions									
	Normal Duty					Heavy Duty				
	Nominal rating		3kHz	6kHz	12kHz	Nominal rating		3kHz	6kHz	12kHz
	kW	hp				kW	hp			
SK4201	18.5	25	517	589		15	20	428	488	
SK4202	22	30	611	694		18.5	25	517	589	
SK4203	30	40	810	916		22	30	611	694	
SK4401	37	50	714	914		30	50	629	704	
SK4402	45	60	882	995		37	60	780	704	
SK4403	55	75	1070	1217		45	75	976	854	
SK4601	18.5	25	409	590		15	20	360	519	
SK4602	22	30	496	712		18.5	25	409	590	
SK4603	30	40	660	941		22	30	496	712	
SK4604	37	50	798	1083		30	40	660	941	
SK4605	45	60	985	1080		37	50	798	1083	
SK4606	55	75	1060	1130		45	60	873	1042	

**NOTE**

For the definition of ambient temperature, see section 5.3.5 *Enclosure design and drive ambient temperature* on page 77.

Table 2-33 Losses @ 50°C (122°F) ambient for wall mounted drives

Model	Drive losses (W) taking into consideration any current derating for the given conditions									
	Normal Duty					Heavy Duty				
	Nominal rating		3kHz	6kHz	12kHz	Nominal rating		3kHz	6kHz	12kHz
	kW	hp				kW	hp			
SK4201	18.5	25	517	589		15	20	428	488	
SK4202	22	30	611	694		18.5	25	517	589	
SK4203	30	40	671	761		22	30	611	694	
SK4401	37	50	714	898		30	50	629	638	
SK4402	45	60	882	898		37	60	716	638	
SK4403	55	75	877	912		45	75	876	775	
SK4601	18.5	25	409	590		15	20	360	519	
SK4602	22	30	496	712		18.5	25	409	590	
SK4603	30	40	660	805		22	30	496	712	
SK4604	37	50	798	805		30	40	660	805	
SK4605	45	60	850	805		37	50	798	805	
SK4606	55	75	871	816		45	60	871	816	



## 2.8 Size 5

### 2.8.1 Power and current ratings (derating for switching frequency and temperature)

Table 2-34 Maximum permissible continuous output current @ 40°C (104°F) ambient for wall mounted drives

Model	Normal Duty					Heavy Duty				
	Nominal rating		Maximum continuous output current (A) @ each switching frequency			Nominal rating		Maximum continuous output current (A) @ each switching frequency		
	kW	hp	3kHz	6kHz	12kHz	kW	hp	3kHz	6kHz	12kHz
SK5401	75	100	138	118		55	100	124	82.4	
SK5402	90	125	168	129		75	125	156	109	
SK5601	75	100	84	69		55	75	63	52	
SK5602	90	125	99	69		75	100	85	52	

Table 2-35 Maximum permissible continuous output current @ 50°C (122°F) ambient for wall mounted drives

Model	Normal Duty					Heavy Duty				
	Nominal rating		Maximum continuous output current (A) @ each switching frequency			Nominal rating		Maximum continuous output current (A) @ each switching frequency		
	kW	hp	3kHz	6kHz	12kHz	kW	hp	3kHz	6kHz	12kHz
SK5401	75	100	138	105.9		55	100	112.7	74.5	
SK5402	90	125	141	112		75	125	140	99.0	
SK5601	75	100	83	51		55	75	63	47	
SK5602	90	125	83	51		75	100	75	45	

**NOTE**

For the definition of ambient temperature, see section 5.3.5 *Enclosure design and drive ambient temperature* on page 77.

### 2.8.2 Drive losses

Table 2-36 Losses @ 40°C (104°F) ambient for wall mounted drives

Model	Drive losses (W) taking into consideration any current derating for the given conditions									
	Normal Duty					Heavy Duty				
	Nominal rating		3kHz	6kHz	12kHz	Nominal rating		3kHz	6kHz	12kHz
	kW	hp				kW	hp			
SK5401	75	100	1471	1640		55	100	1311	1150	
SK5402	90	125	1830	1781		75	125	1681	1508	
SK5601	75	100	1818	2258		55	75	1345	1763	
SK5602	90	125	2176	2215		75	100	1792	1714	

**NOTE**

For the definition of ambient temperature, see section 5.3.5 *Enclosure design and drive ambient temperature* on page 77.

Table 2-37 Losses @ 50°C (122°F) ambient for wall mounted drives

Model	Drive losses (W) taking into consideration any current derating for the given conditions									
	Normal Duty					Heavy Duty				
	Nominal rating		3kHz	6kHz	12kHz	Nominal rating		3kHz	6kHz	12kHz
	kW	hp				kW	hp			
SK5401	75	100	1471	1462		55	100	1186	1047	
SK5402	90	125	1500	1543		75	125	1500	1366	
SK5601	75	100	1785	1689		55	75	1345	1763	
SK5602	90	125	1785	1688		75	100	1609	1502	

## 2.9 Size 6

### 2.9.1 Power and current ratings (derating for switching frequency and temperature)

Table 2-38 Maximum permissible continuous output current @ 40°C (104°F) ambient for wall mounted drives

Model	Normal Duty					Heavy Duty				
	Nominal rating		Maximum continuous output current (A) @ each switching frequency			Nominal rating		Maximum continuous output current (A) @ each switching frequency		
	kW	hp	3kHz	6kHz	12kHz	kW	hp	3kHz	6kHz	12kHz
SK6401	110	150	202	164.1		90	150	180	134.5	
SK6402	132	200	236	157.7		110	150	210	129.7	
SK6601	110	150	125	74		90	125	100	74	
SK6602	132	175	144	74		110	150	125	74	

Table 2-39 Maximum permissible continuous output current @ 50°C (122°F) ambient for wall mounted drives

Model	Normal Duty					Heavy Duty				
	Nominal rating		Maximum continuous output current (A) @ each switching frequency			Nominal rating		Maximum continuous output current (A) @ each switching frequency		
	kW	hp	3kHz	6kHz	12kHz	kW	hp	3kHz	6kHz	12kHz
SK6401	110	150	191.5	147.6		90	150	180	121.5	
SK6402	132	200	198.4	138.1		110	150	190	116.2	
SK6601	110	150	98	59		90	125	98	59	
SK6602	132	175	98	59		110	150	98	59	

**NOTE**

For the definition of ambient temperature, see section 5.3.5 *Enclosure design and drive ambient temperature* on page 77.

### 2.9.2 Drive losses

Table 2-40 Losses @ 40°C (104°F) ambient for wall mounted drives

Model	Drive losses (W) taking into consideration any current derating for the given conditions									
	Normal Duty					Heavy Duty				
	Nominal rating		3kHz	6kHz	12kHz	Nominal rating		3kHz	6kHz	12kHz
	kW	hp				kW	hp			
SK6401	110	150	2058	2153		90	150	1817	1772	
SK6402	132	200	2477	2255		110	150	2192	1888	
SK6601	110	150	2573	2438		90	125	2573	2438	
SK6602	132	175	3106	2438		110	150	3106	2438	

**NOTE**

For the definition of ambient temperature, see section 5.3.5 *Enclosure design and drive ambient temperature* on page 77.

Table 2-41 Losses @ 50°C (122°F) ambient for wall mounted drives

Model	Drive losses (W) taking into consideration any current derating for the given conditions									
	Normal Duty					Heavy Duty				
	Nominal rating		3kHz	6kHz	12kHz	Nominal rating		3kHz	6kHz	12kHz
	kW	hp				kW	hp			
SK6401	110	150	1942	1939		90	150	1817	1610	
SK6402	132	200	2068	1997		110	150	1979	1715	
SK6601	110	150	2084	1978		90	125	2084	1978	
SK6602	132	175	2084	1978		110	150	2084	1978	

For through-panel mounting losses see Table 5-6 on page 64.

## 2.10 Derating with glanding box and Cover kit (size A only)

**Table 2-42** Size A derating with glanding box and Cover kit installed to drive

Model	Output current
SKA1200037	1.7A
SKA1200055	2.2A
SKA1200075	3.0A

For sizes B and C there is no derating due to forced ventilation from fan.

This is needed to allow the drive to meet the requirements of UL type 1.

### 3 Drive voltage levels

Condition	110V drives	200V drives	400V drives	575V drives	690V drives
OV trip level	415 Vdc	415 Vdc	830 Vdc	990 Vdc	1190 Vdc
Braking level	390 Vdc	390 Vdc	780 Vdc	930 Vdc	1120Vdc
Rated upper level (AC mains +10% x 1.4142)	373 Vdc	373 Vdc	747 Vdc	895 Vdc	1073 Vdc
Rated lower level (AC mains -10% x 1.4142)	255 Vdc	255 Vdc	484 Vdc	636 Vdc	636 Vdc
*UV reset level	215 Vdc	215 Vdc	425 Vdc	590 Vdc	590 Vdc
UV trip level	175 Vdc	175 Vdc	330 Vdc	435 Vdc	435 Vdc
Standard ramp voltage	375 Vdc	375 Vdc	Eur: 750 Vdc USA: 775 Vdc	895 Vdc	1075 Vdc

\* These are the absolute minimum DC voltages that the drive can be supplied with. If the drive is not supplied with at least this voltage, it will not reset out of a UV trip at power up.

Output frequency: 0 to 1500Hz

Output voltage: 3 phase, 0 to drive rating (240, 480, 575 or 690 Vac maximum set by Pr 08).

#### Low DC bus operation (Pr 6.10)

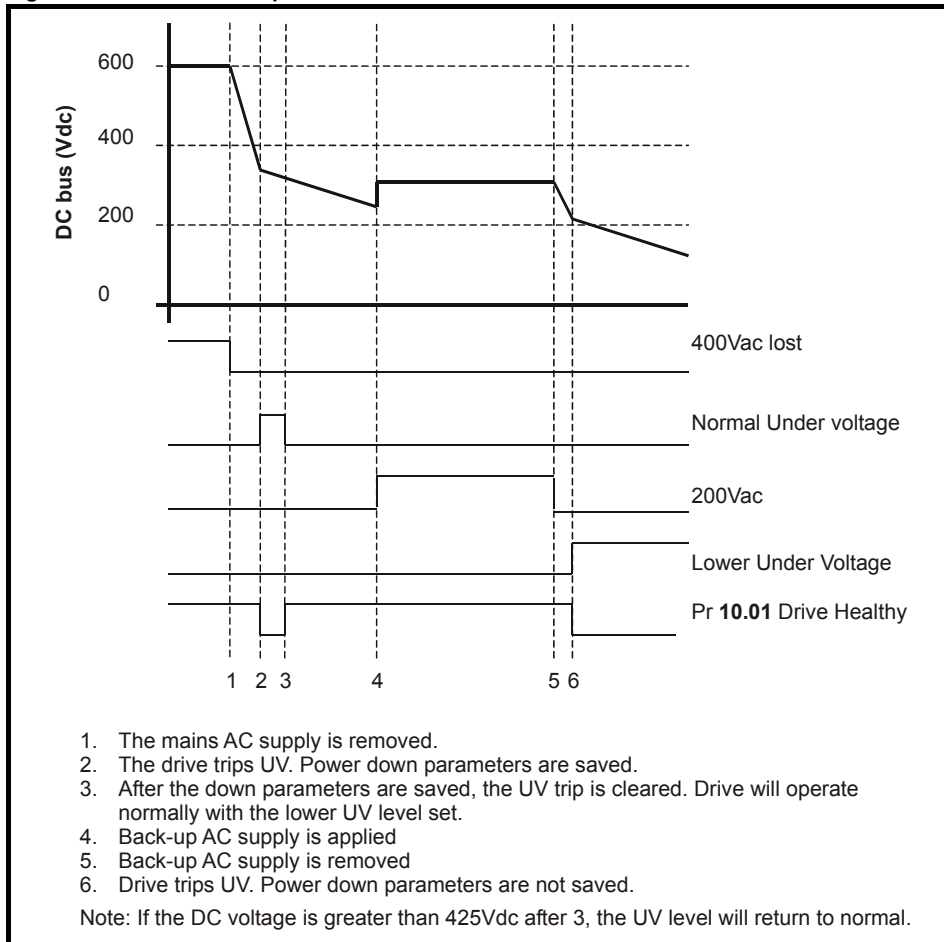
- 0 Low DC bus operation disabled
- 1 Low DC bus operation enabled

The Low DC bus operation is designed to enable 3 phase 400VAC (medium voltage) Commander SK's to be run off a single phase 200VAC (low voltage) supply in the event of a primary 400VAC supply failure.

When the primary supply fails, the back up supply can be switched in. This will allow the drive to control the motor at a reduced power, for example to move an elevator up or down to the next floor.

There is no de-rating as such when low DC bus operation is enabled however the power will be limited by the reduced voltage and ripple generated on the DC bus of the drive.

Figure 3-1 Low DC bus operation



**NOTE**

This function is only available on sizes B, C and D.

When Pr 6.10 is enabled and the DC bus voltage is less than 330VDC, the drives display will flash LoAC (Low AC) to indicate that it is running off the low voltage back up supply.

**NOTE**

This mode is designed for use with a backup power supply and not for using a 400VAC (medium voltage) Commander SK in a 200VAC (low voltage) application. As shown in the above diagram, the drives power down save parameters are saved at point 2. If the drive was to be used on a 200VAC supply, the DC bus will never fall through point 2 and power down save parameters will not be saved.

**Low DC bus operation voltage levels (Pr 6.10 enabled)**

- >425Vdc - normal operation
- <330Vdc - LoAC operation
- <230Vdc - UV trip

**3.1 Input voltage**

**3.1.1 Single phase**

100V to 120V ±10%

48Hz to 62Hz

or:

200V to 240V ±10%

48Hz to 62Hz

**3.1.2 Three phase 200V**

200V to 240V ±10%

48Hz to 62Hz (48Hz to 65Hz for size 2 to 6)

Phase imbalance 3% (between phases) or 2% negative phase sequence (IEC 146-1-1 Immunity class C)

**3.1.3 Three phase 400V**

380V to 480V ±10%

48Hz to 62Hz (48Hz to 65Hz for size 2 to 6)

Phase imbalance 3% (between phases) or 2% negative phase sequence (IEC 146-1-1 Immunity class C)

It is possible to run the drives on lower supply voltages than those specified above (up to -20%) but only with de-rating of the product. Running a 400V product on a 230V single phase supply (at a very much reduced output power) is possible on frame sizes B & C.

**3.1.4 Three phase 575V**

500V to 575V ±10%

48Hz to 65Hz

**3.1.5 Three phase 690V**

500V to 690V ±10%

48Hz to 65Hz

The drive is suitable in a circuit capable of delivering not more than 100,000 rms symmetrical Amperes at 264Vac rms maximum (200v drives), 528Vac rms maximum (400V drives), 600Vac rms maximum (575V and 690V drives) or 132Vac rms (110V drives).

For drives without a D.C. Bus choke (up to 4kW), an input line reactor should be used if the fault level exceeds 5kA.

**3.2 Single phase ratings (size 2 and 3)**

See Table 3-1 for the single phase supply capability of Commander SK.

**NOTE**

The supply should be connected between L1 and L2.

The single phase supply should have the same RMS voltage as the line to line RMS voltage that the drive is designed for. Minimum and maximum voltages are the same as for 3 phase operation.

With a single-phase supply the drive power rating is considerably reduced in comparison with the normal case. The output current capability is not reduced. There are two possible modes of operation:

1. Motor matched to the drive power capability. In this case the motor can deliver its full rated torque at any speed up to base speed, but

this is less than the drive capability at reduced speed. Table 3-1 shows the power and current ratings for a suitable motor.

2. Motor run with restricted power. In this case the motor may have any current rating up to the normal output current rating of the drive. The available torque will be reduced at higher speeds in order to avoid exceeding the power restriction. Table 3-1 shows the power ratings for a suitable motor. The current rating should be selected to suit the required maximum torque at low speed.

The current and power ratings given are for continuous operation.

A PH trip would result if the limits are exceeded.

Continuous operation at output currents above the values given will result in the drive tripping O.ht3.

Drive rated output power is given for 220V, 400V and 525V supplies.

Values have been derived from extensive calculations and take into account capacitor ripple current and life time, rectifier peak and RMS current and supply RMS current.

Supply fuses and cable sizes need to be the same value as specified for the drive operating with a 3 phase supply at normal rated power. This is because with a single phase supply the RMS supply current is much greater for the same output power.

There is no further derating due to switching frequency as it is the input stage and DC bus components which derate the drive.

**Table 3-1 Single phase ratings (size 2 and 3)**

Drive type	Corresponding motor rated current (A)	Drive rated output power (kW)
SK2201	11.6*	3.5*
SK2202		
SK2203		
SK3201	28.4	8.5
SK3202	28.4	8.5
SK2401	6.6*	3.4*
SK2402	6.6	3.4
SK2403	6.6	3.4
SK3401	11.4	5.9
SK3402	11.4	5.9
SK3403	11.4	5.9
SK3501	5.4	3.7
SK3502	6.1	4.2
SK3503	8.4	5.7
SK3504	11.0	7.5
SK3505	12.0	8.2
SK3506	12.0	8.2
SK3507	12.0	8.2

\* These values will be slightly less since there is less DC bus capacitance with these Commander SK models compared to the equivalent Unidrive SP models.

## 4 DC bus design

### 4.1 Commander SK size A to D

Table 4-1 Commander SK 200V units DC bus data

Model	DC bus Capacitance $\mu\text{F}$	DC bus inductance mH	Inrush resistance at 25°C $\Omega$	Peak inrush current A
SKA1200025	330		22	17.0
SKA1200037	390		22	17.0
SKA1200055	660		22	17.0
SKA1200075	780		22	17.0
SKBD200110	940		13.6	27.4
SKBD200150	1410		13.6	27.4
SKCD200220	1880		20.4	18.3
SKDD200300	1760	0.7	20.4	19.1
SKD3200400	1760	0.7	20.4	19.1

Table 4-2 Commander SK 400V units DC bus data

Model	DC bus Capacitance $\mu\text{F}$	DC bus inductance mH	Inrush resistance at 25°C $\Omega$	Peak inrush current A
SKB3400037	165		44	17.0
SKB3400055	165		44	17.0
SKB3400075	165		44	17.0
SKB3400110	195		44	17.0
SKB3400150	235		44	17.0
SKC3400220	470		66	11.3
SKC3400300	470		66	11.3
SKC3400400	470		66	11.3
SKD3400550	440	1.8	66	11.9
SKD3400750	440	1.8	66	11.9

#### NOTE

The 110V drives cannot be DC bus paralleled.

The Commander SK size B,C,D & 2,3 have a soft-start circuit, which is in circuit when the drive is supplied from the AC or DC terminals.

### 4.2 Commander SK size 2 to 6

Table 4-3 Commander SK size 2 DC bus data

Model	DC bus Capacitance $\mu\text{F}$	DC bus inductance mH	Peak inrush current A	Inrush resistance at 25°C $\Omega$
SK2201	1880	1.4	12	30
SK2202	1880	1.4		
SK2203	1880	1.4		
SK2401	470	1.4	24	
SK2402	705	1.4		
SK2403	705	1.4		
SK2404	705	1.4		

**Table 4-4 Commander SK Size 3 DC bus data**

Model	DC bus Capacitance μF	DC bus inductance mH	Peak inrush current A	Inrush resistance at 25°C Ω
SK3201	5400	0.7	8	50
SK3202	5400	0.7		
SK3401	1350	0.7	14	
SK3402	1350	0.7		
SK3403	1350	0.7		
SK3501	1000	4	18	
SK3502	1000	4		
SK3503	1000	4		
SK3504	1000	4		
SK3505	1000	4		
SK3506	1000	4		
SK3507	1000	4		

**Table 4-5 Commander SK size 4 DC bus data**

Model	DC bus Capacitance μF	DC bus inductance mH	Peak inrush current A
SK4201	4400	0.211	73
SK4202	4400	0.211	
SK4203	4400	0.211	
SK4401	1100	0.85	37
SK4402	2200	0.423	73
SK4403	2200	0.423	
SK4601	733	1.27	35
SK4602	733	1.27	
SK4603	733	1.27	
SK4604	733	1.27	
SK4605	733	1.27	
SK4606	733	1.27	

Commander SK size 5 and 6 use AC line chokes instead of DC bus chokes

**Table 4-6 Commander SK size 5 DC bus data**

Model	DC bus Capacitance μF	AC line inductance per phase (mH)	Peak inrush current A
SK5401	3300	0.150	110
SK5402	3300	0.150	
SK5601	1467	0.470	70
SK5602	1467	0.470	

**Table 4-7 Commander SK size 6 DC bus data**

Model	DC bus Capacitance μF	AC line inductance per phase (mH)	Peak inrush current A
SK6401	4400	0.054	
SK6402	5500	0.054	
SK6601	2200	0.313	
SK6602	2200	0.313	

**NOTE**

The inrush current for all drives after a brown-out can be larger than the power-up inrush. For sizes 4 to 6, the inrush current is limited by a controlled rectifier to below the rated current of the drive.

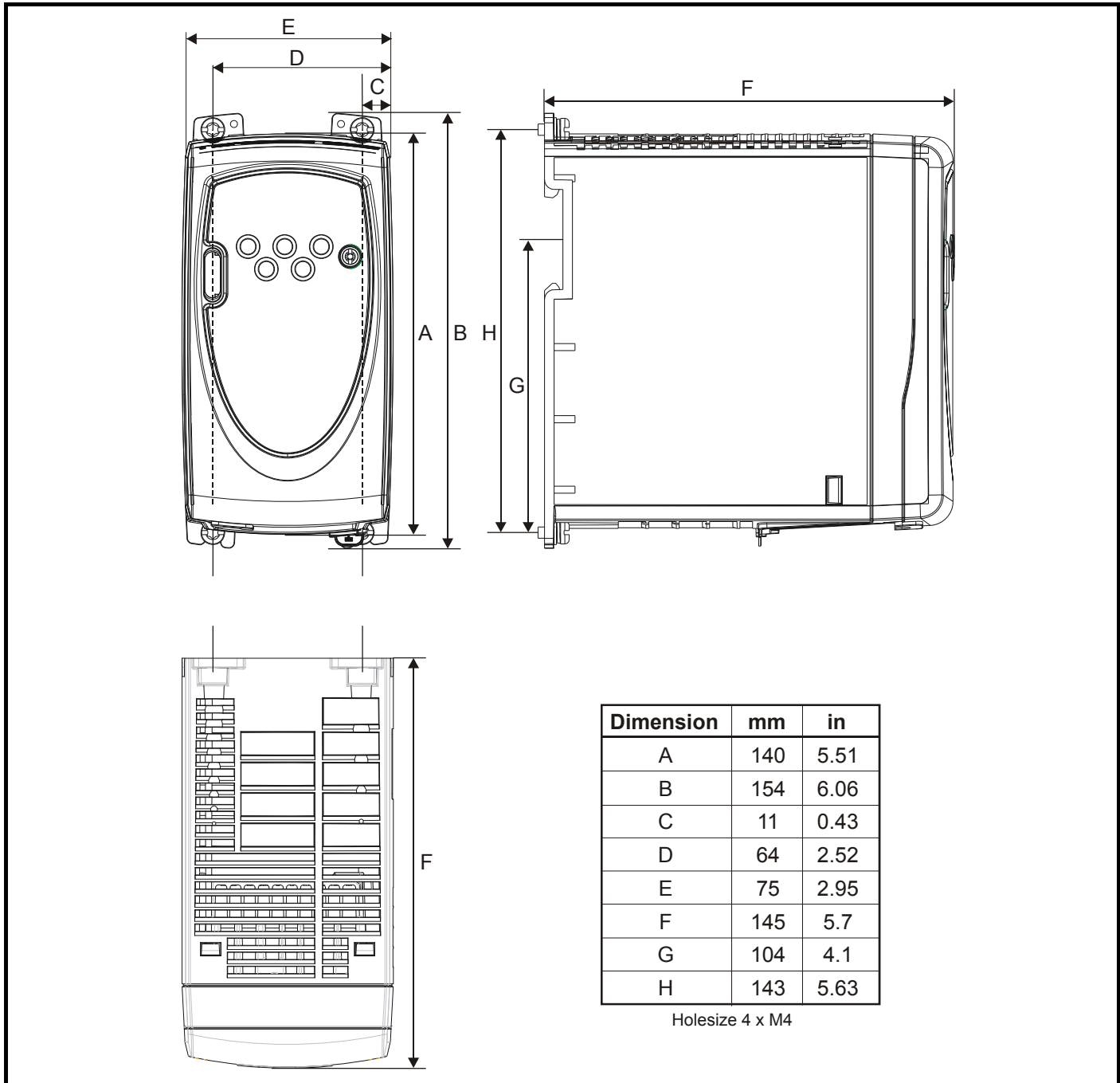
## 5 Mechanical installation

### 5.1 Mounting methods

Commander SK size A to D

#### 5.1.1 Mechanical dimensions

Figure 5-1 Size A mounting dimensions



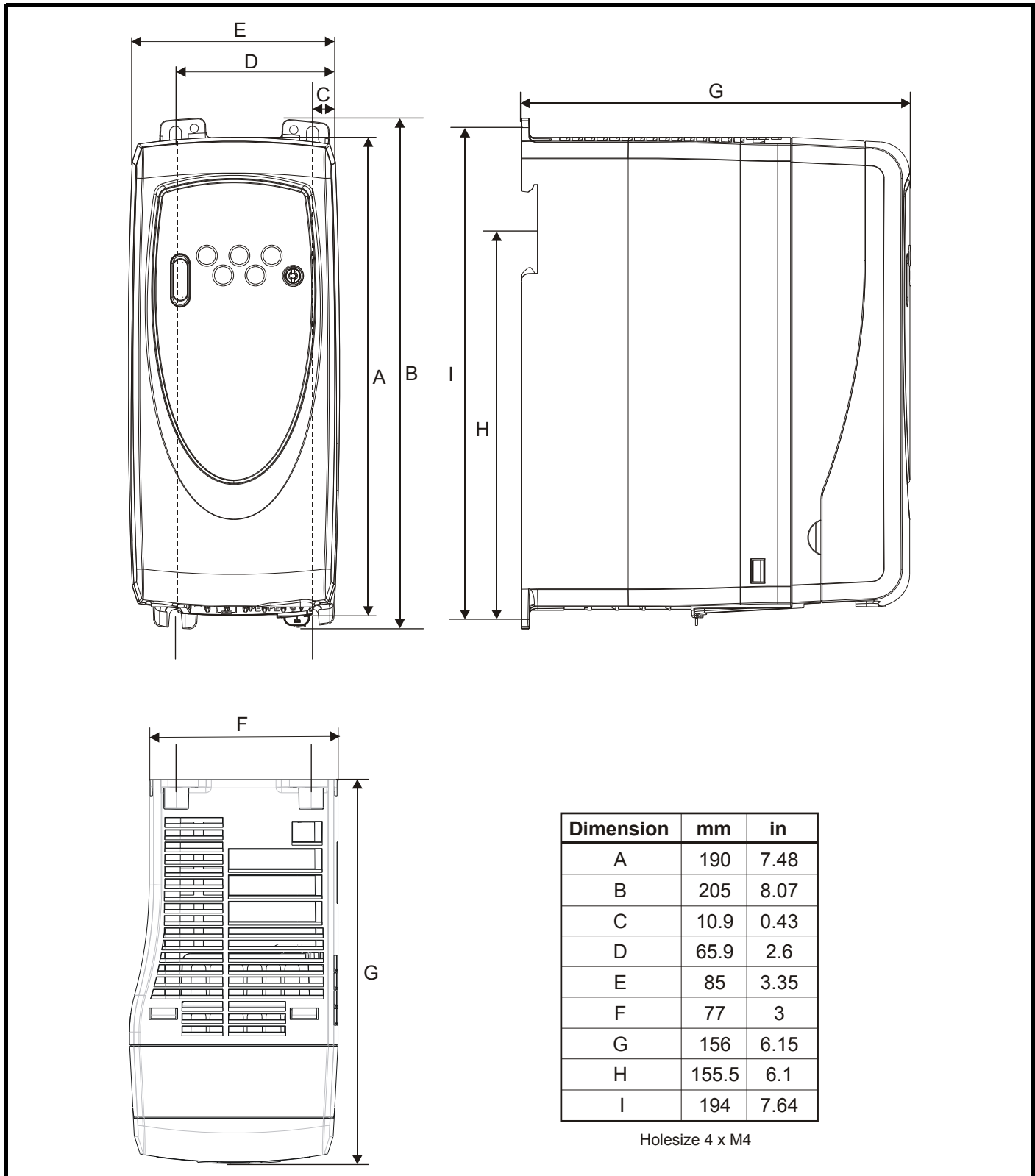
#### NOTE

If DIN rail mounting is used in an installation where the drive is to be subjected to shock or vibration, it is recommended that the bottom mounting screws are used to secure the drive to the back plate. If the installation is going to be subjected to heavy shock and vibration, then it is recommended that the drive is surface mounted rather than DIN rail mounted.

The DIN rail used should conform to DIN46277-3.



**Figure 5-2 Size B mounting dimensions**

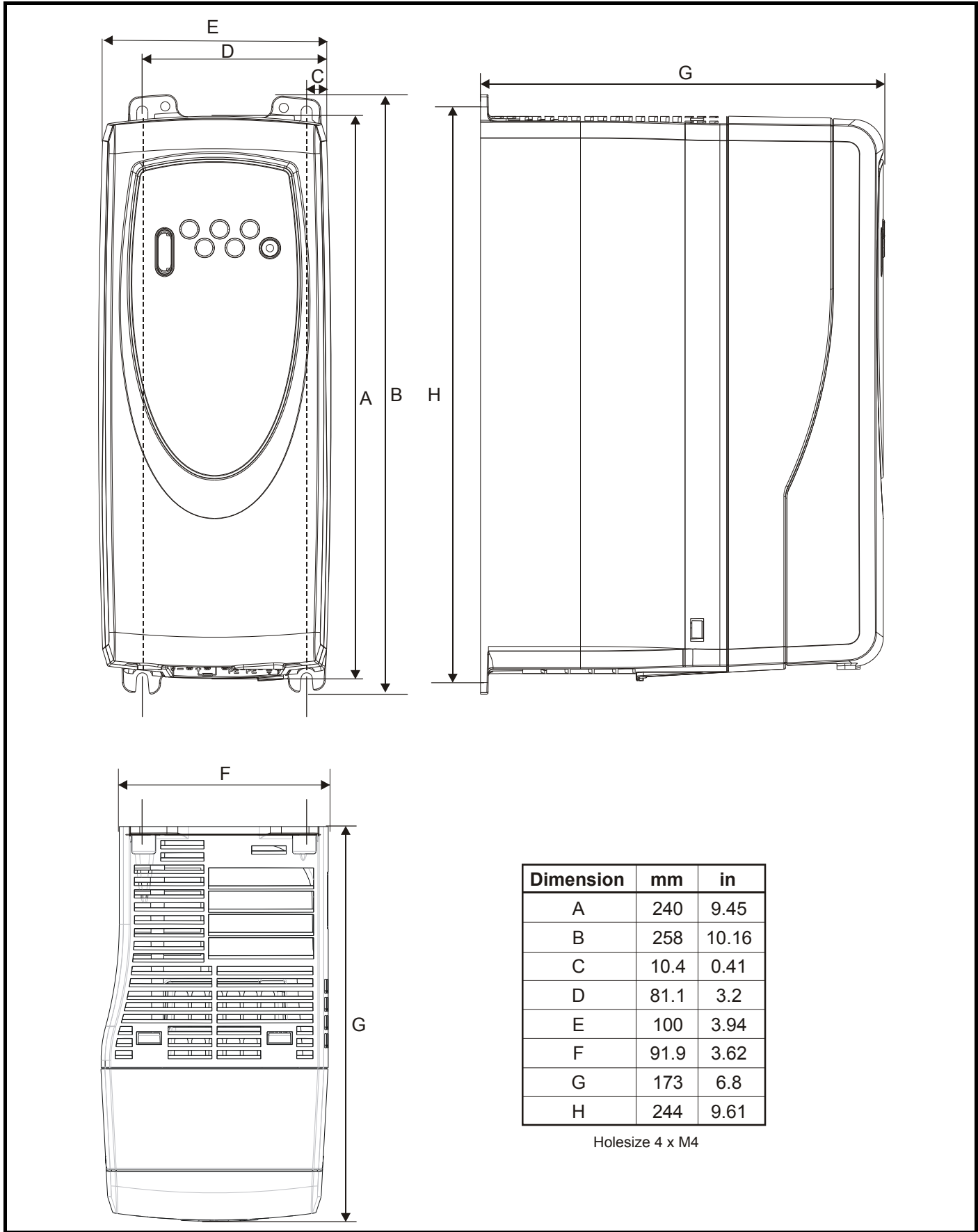


**NOTE**

If DIN rail mounting is used in an installation where the drive is to be subjected to shock or vibration, it is recommended that the bottom mounting screws are used to secure the drive to the back plate. If the installation is going to be subjected to heavy shock and vibration, then it is recommended that the drive is surface mounted rather than DIN rail mounted

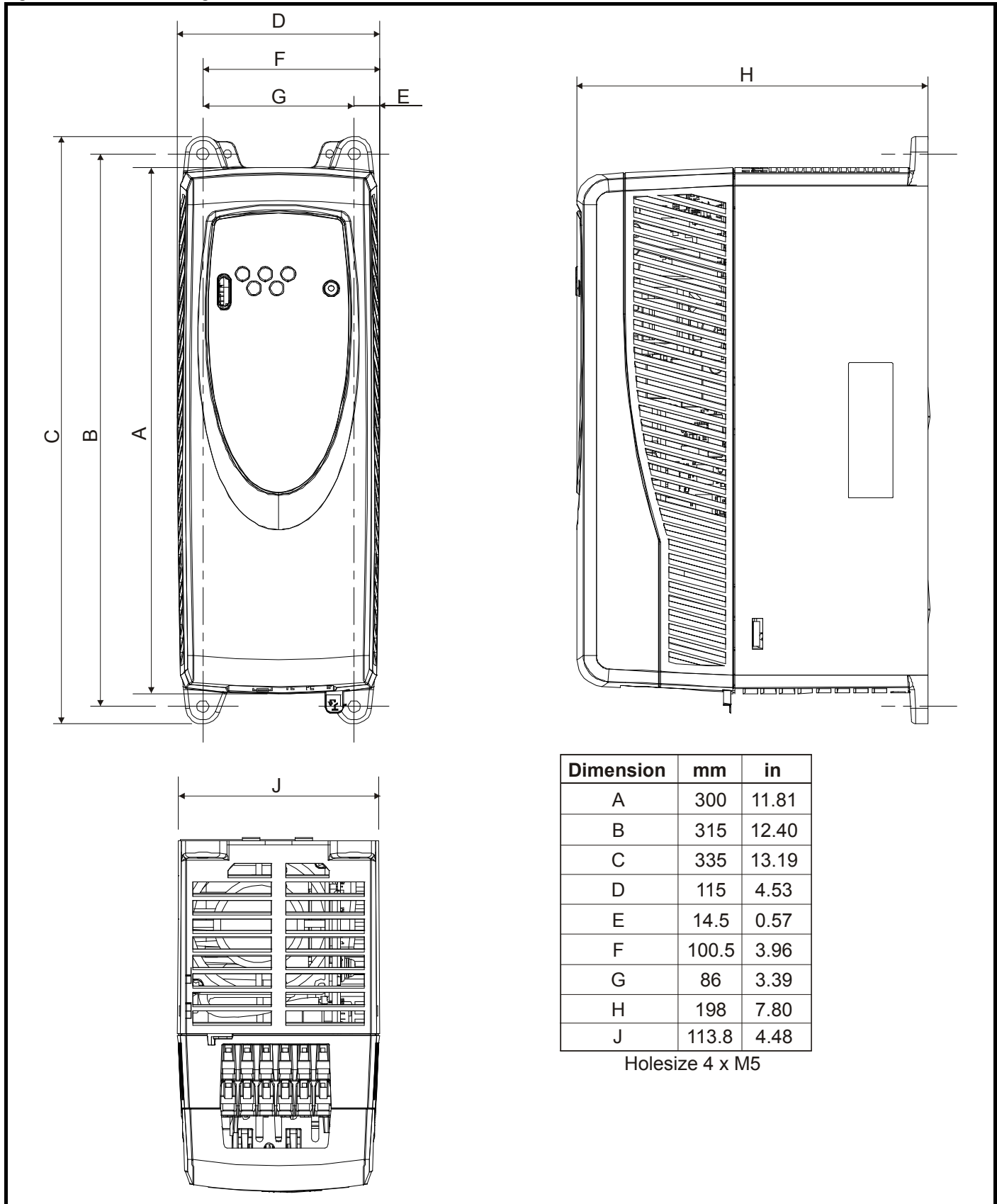
The DIN rail used should conform to DIN46277-3.

**Figure 5-3 Size C mounting dimensions**



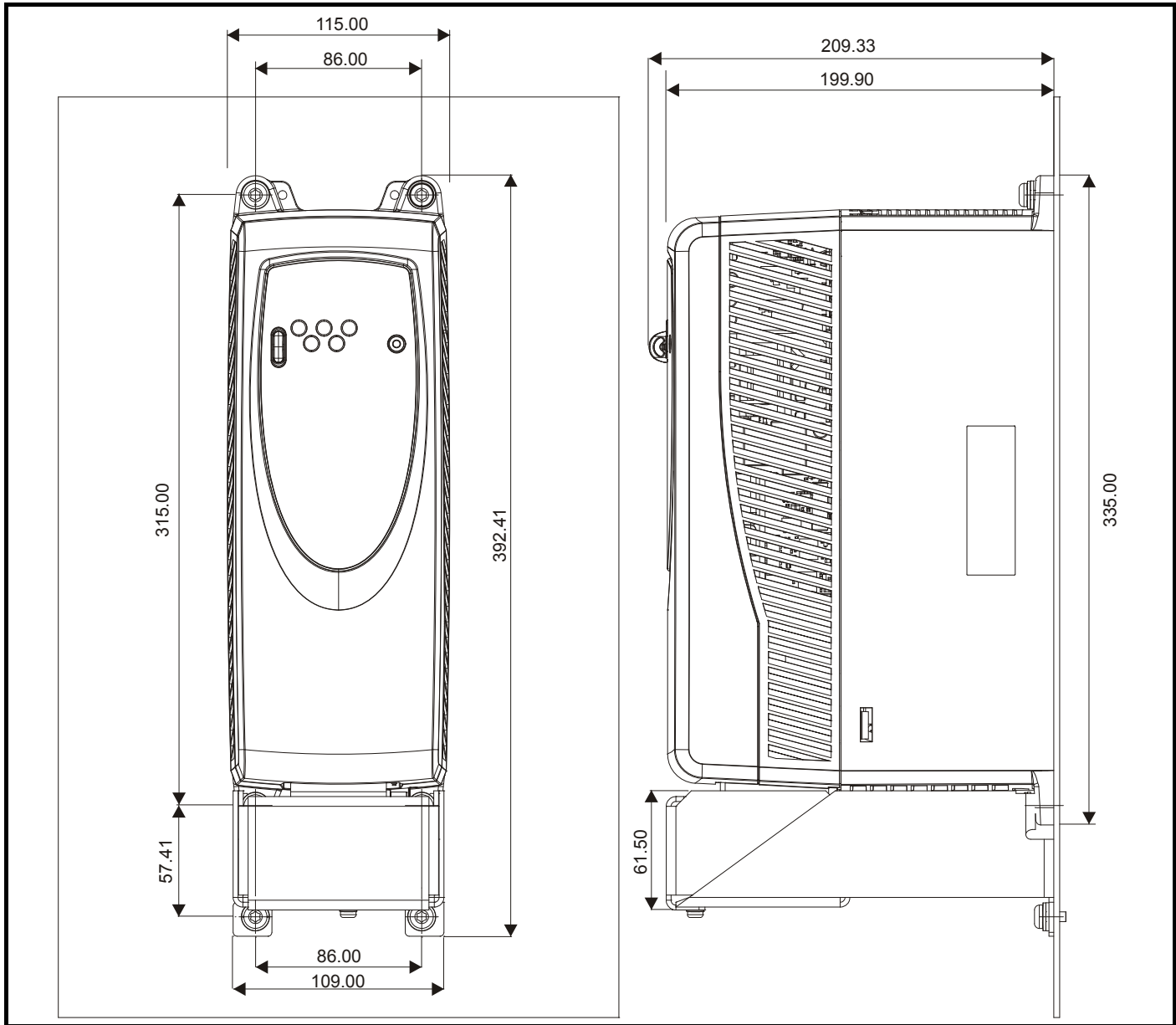
Size C is not DIN rail mountable.

**Figure 5-4 Size D mounting dimensions**



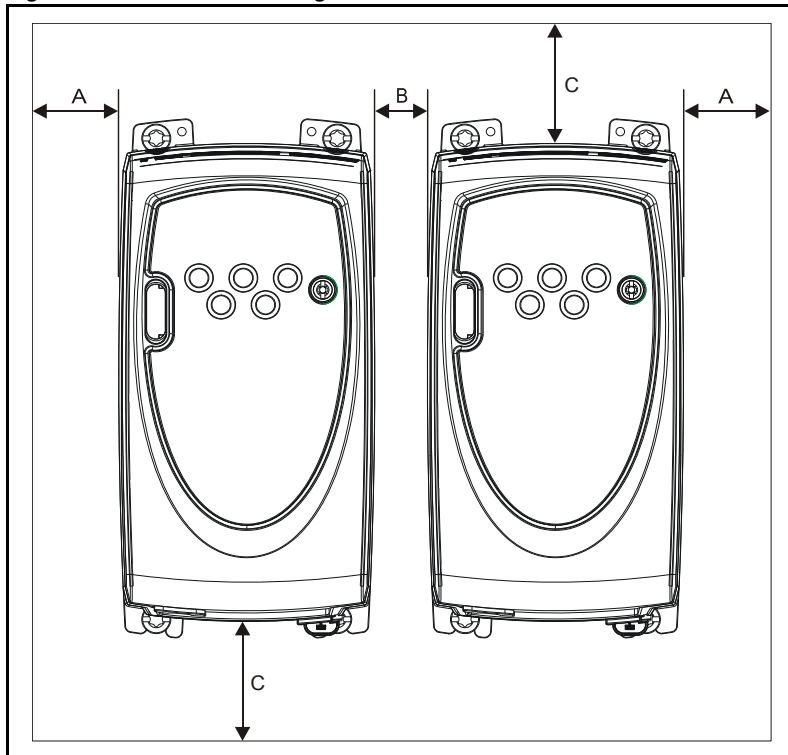
Size D is not DIN rail mountable.

### 5.1.2 Mounting with Conduit Boxes (size D)



### 5.1.3 Minimum mounting clearances

Figure 5-5 Minimum mounting clearances



Drive size	A		B		C	
	mm	in	mm	in	mm	in
A	10	0.39	0	0	100	3.94
B ( $\leq 0.75\text{kW}$ )			10*	0.39*		
B ( $\geq 1.1\text{kW}$ )			0	0		
C			50*	1.97*		
D			0	0		
2 to 6	30	1.18	30	1.18		

\*This is the minimum spacing between drives measured at the base of the drives where it is mounted against a back plate/flat surface.

### Commander SK size 2 to 6

The Commander SK size 2 to 6 can be either surface or through-panel mounted using the appropriate brackets.

The following drawings show the dimensions of the drive and mounting holes for each method to allow the back plate to be prepared.

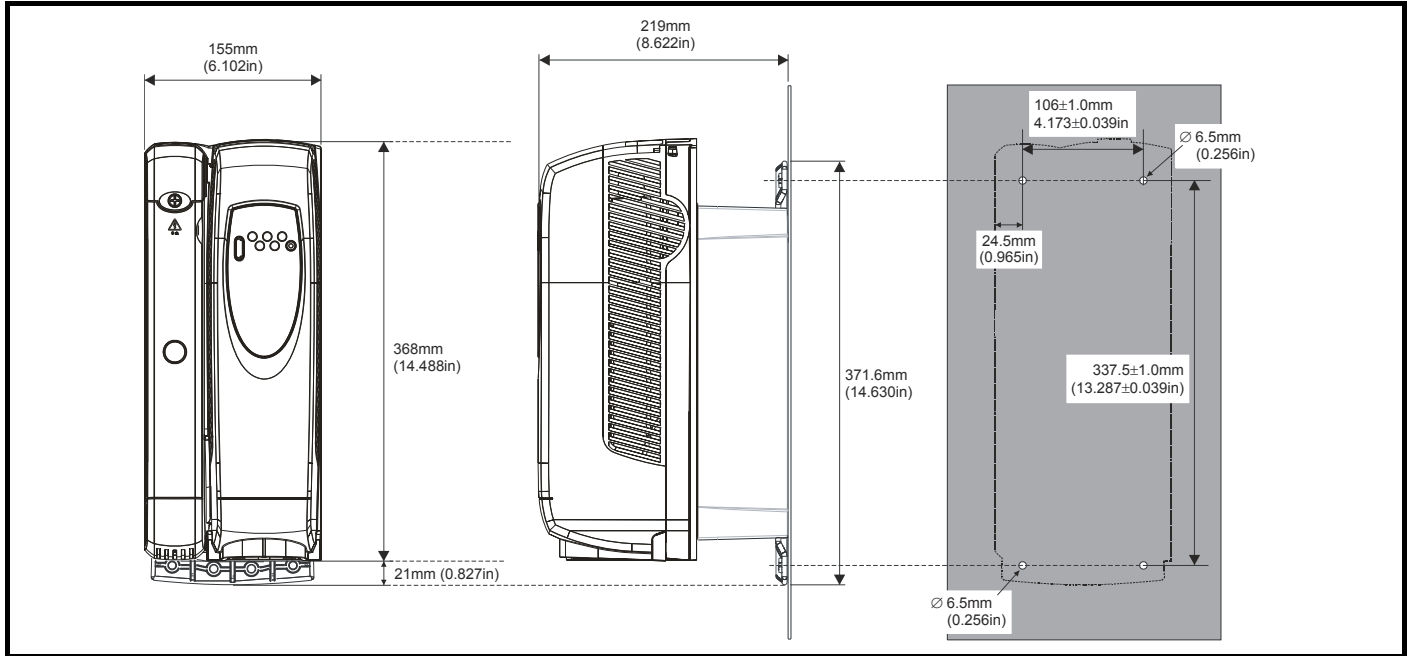


If the drive has been used at high load levels for a period of time, the heatsink can reach temperatures in excess of 70°C (158°F). Human contact with the heatsink should be prevented.

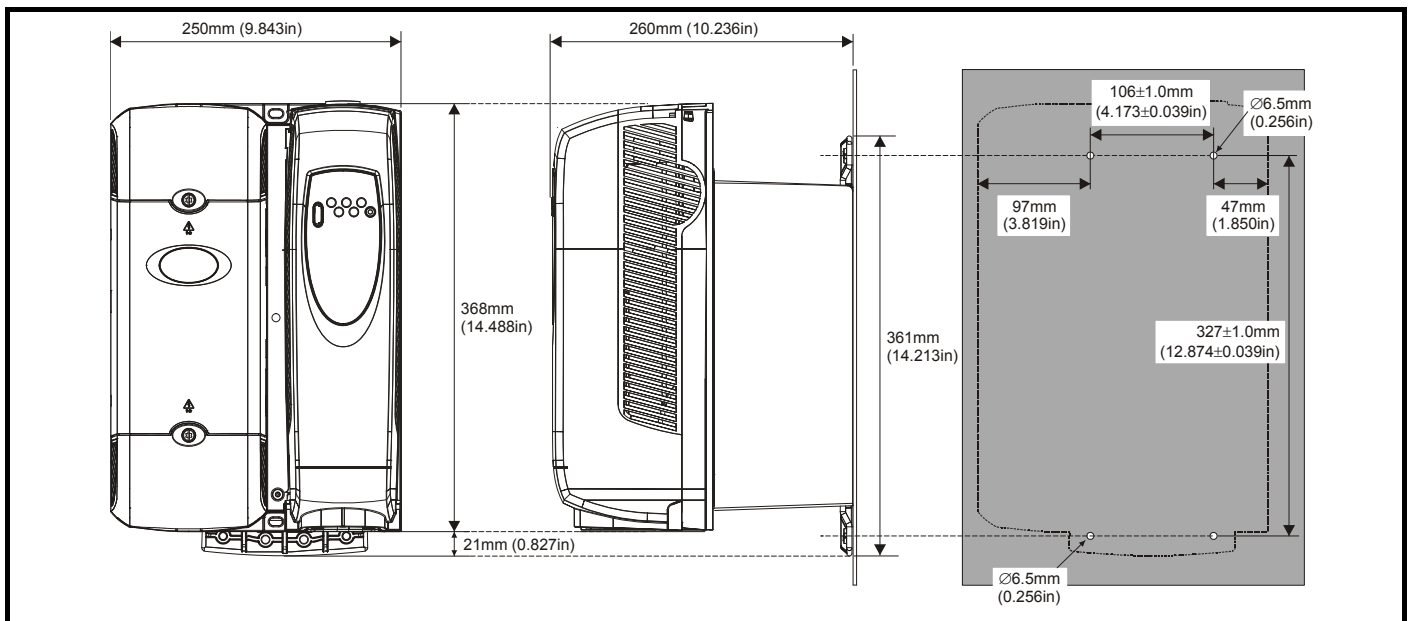
**WARNING**

#### Surface mounting

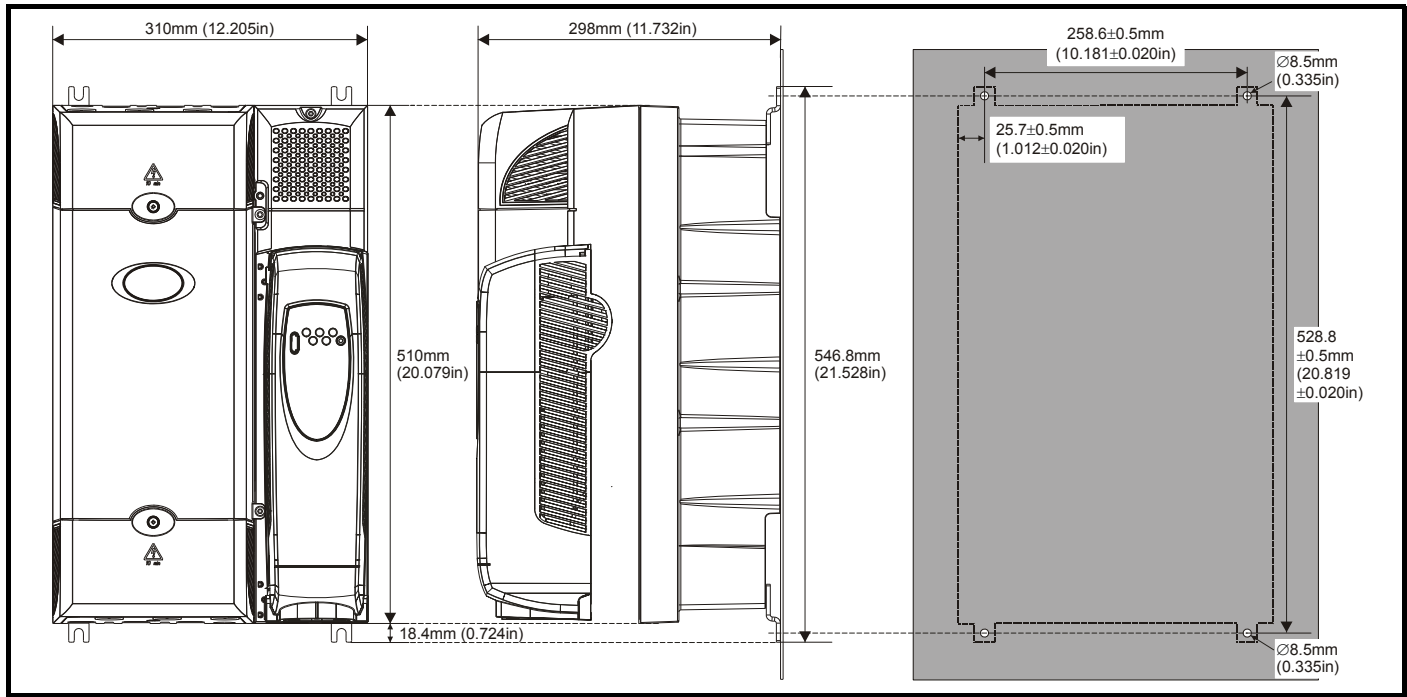
**Figure 5-6 Surface mounting the size 2 drive**



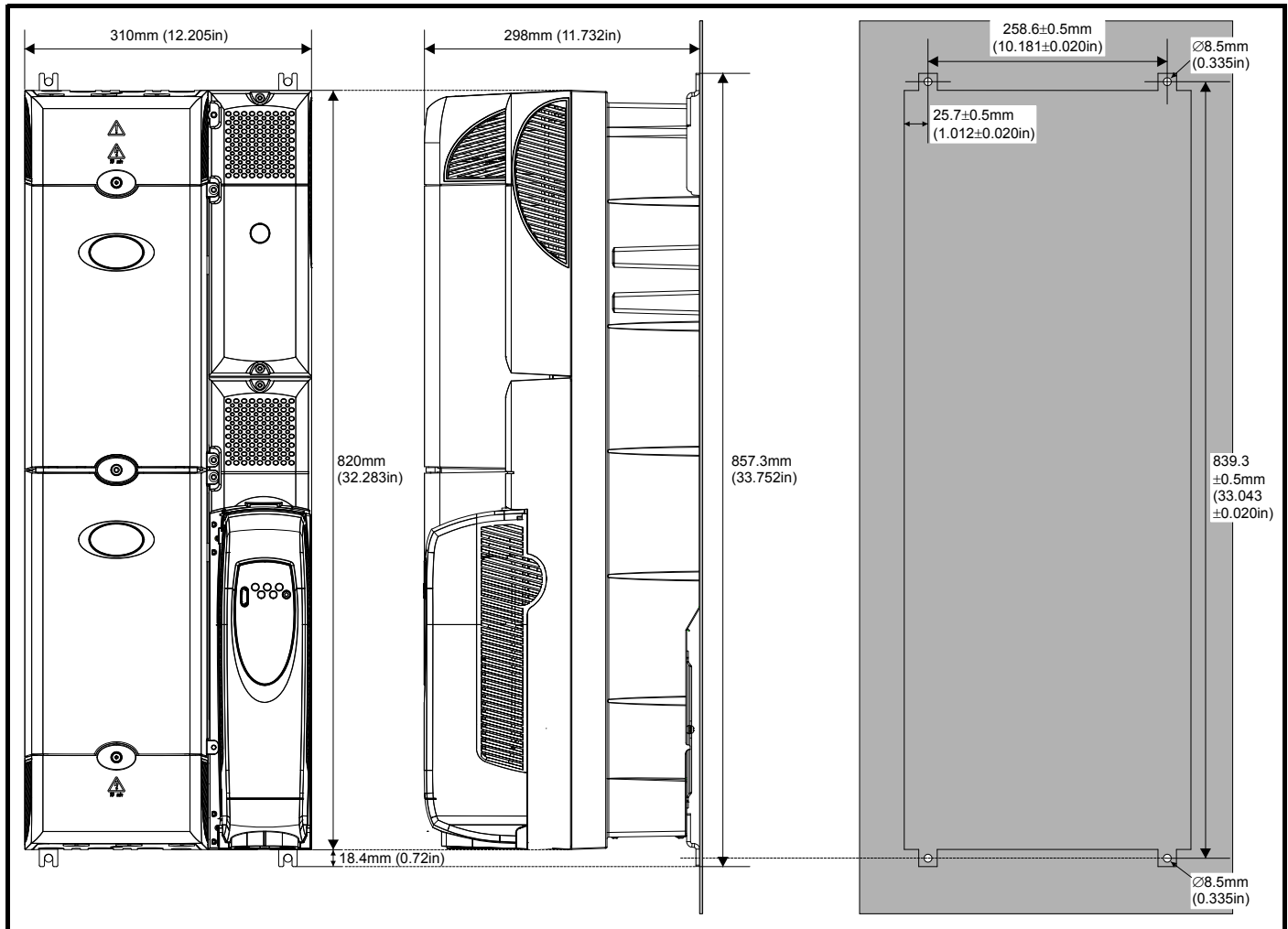
**Figure 5-7 Surface mounting the size 3 drive**



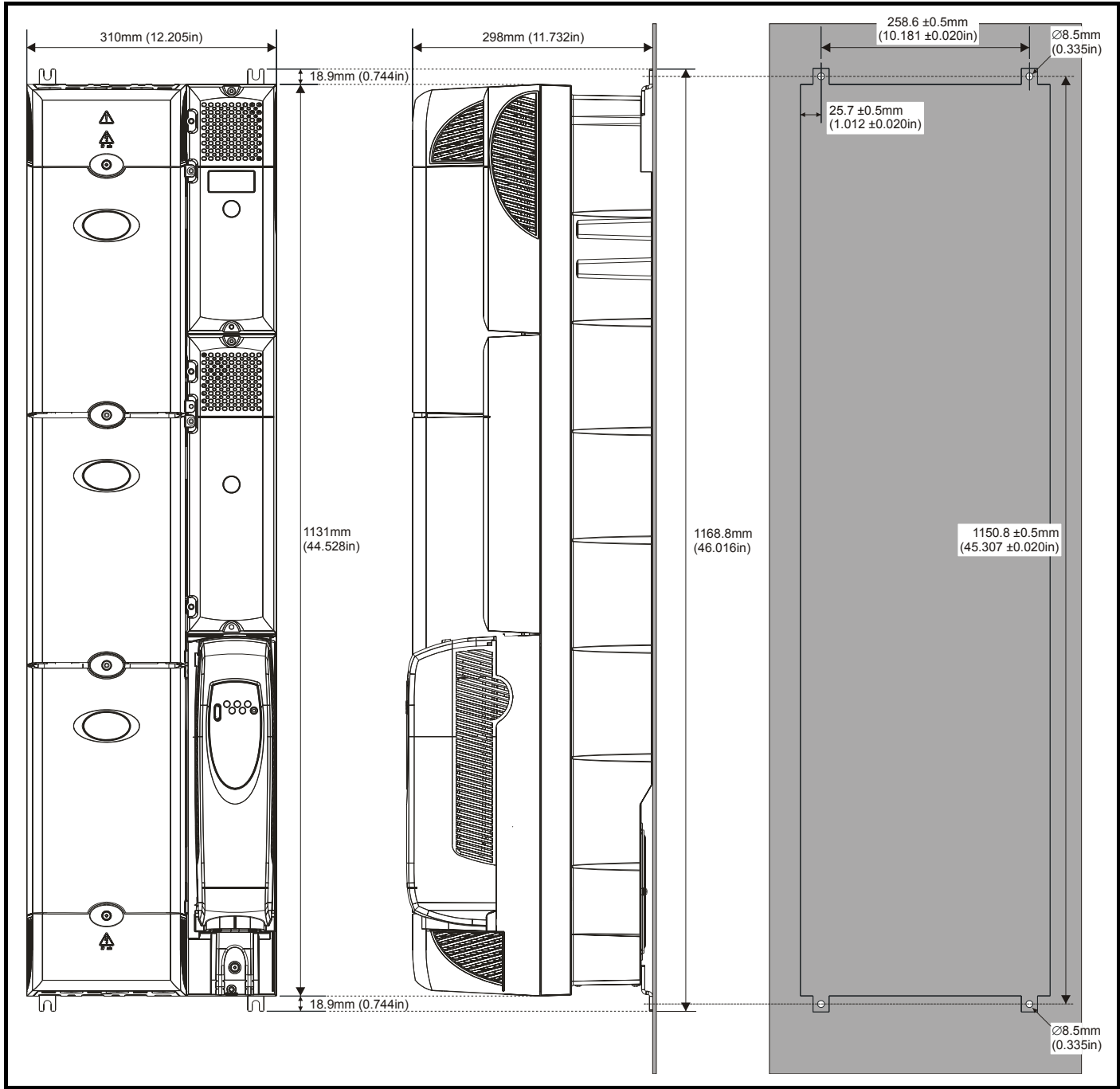
**Figure 5-8 Surface mounting the size 4 drive**



**Figure 5-9 Surface mounting the size 5 drive**



**Figure 5-10 Surface mounting the size 6 drive**

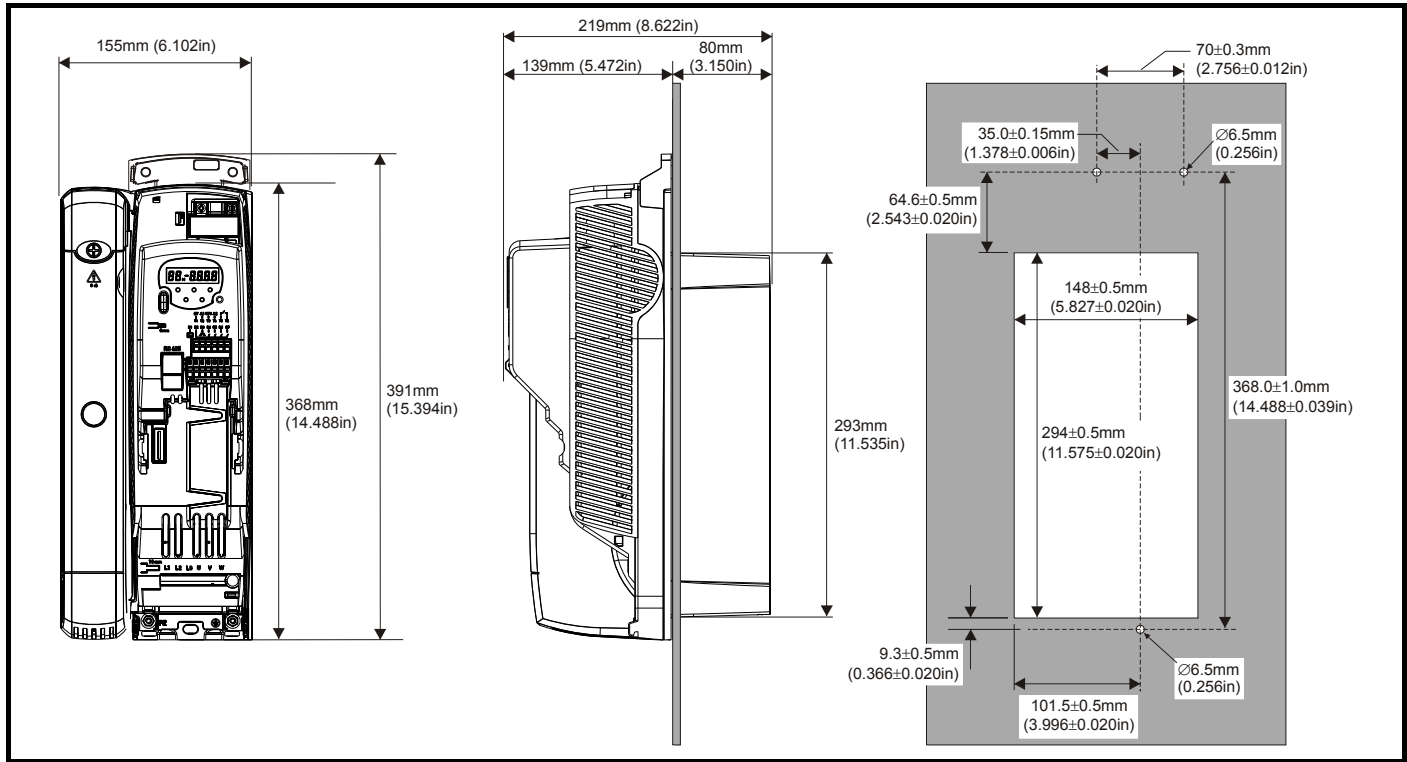




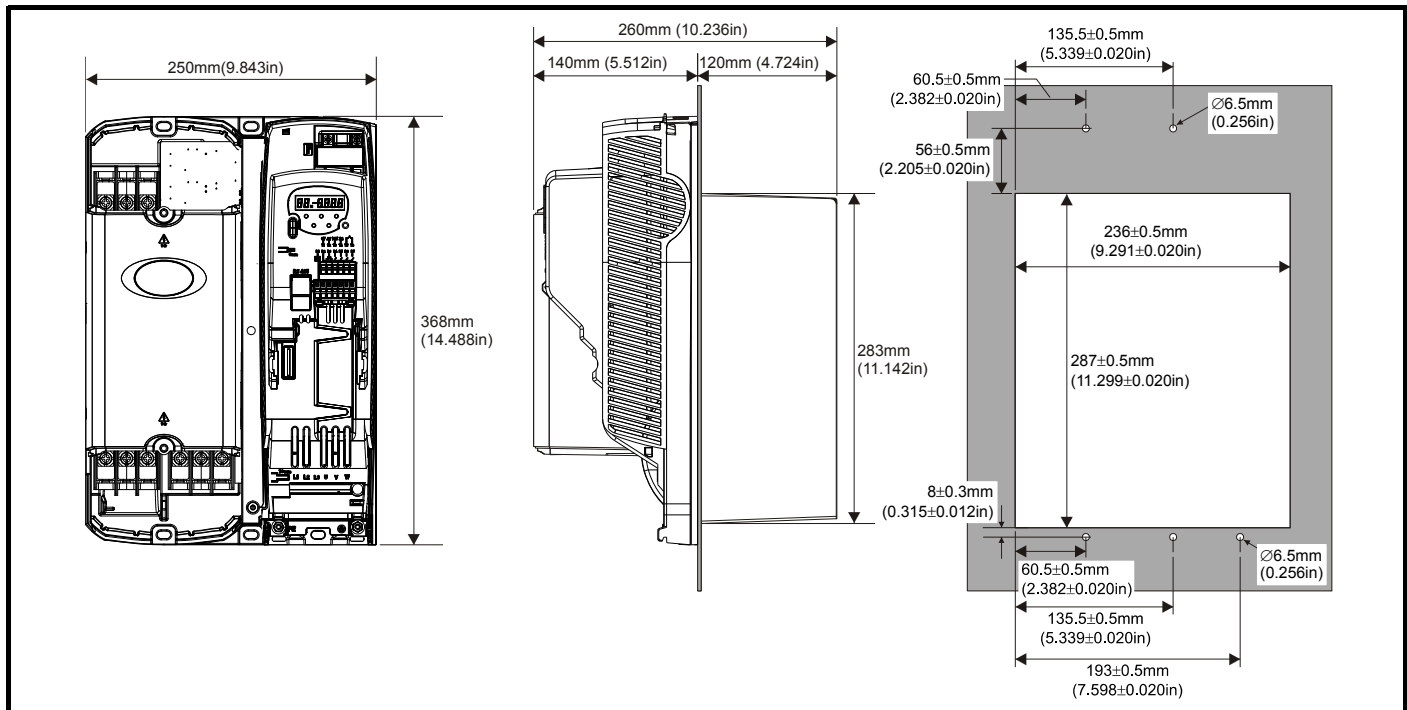
### Through-panel mounting

When the drive is through-panel mounted, the main terminal cover(s) must be removed in order to provide access to the mounting holes. Once the drive has been mounted, the terminal cover(s) can be replaced.

**Figure 5-11 Through-panel mounting of a size 2 drive**



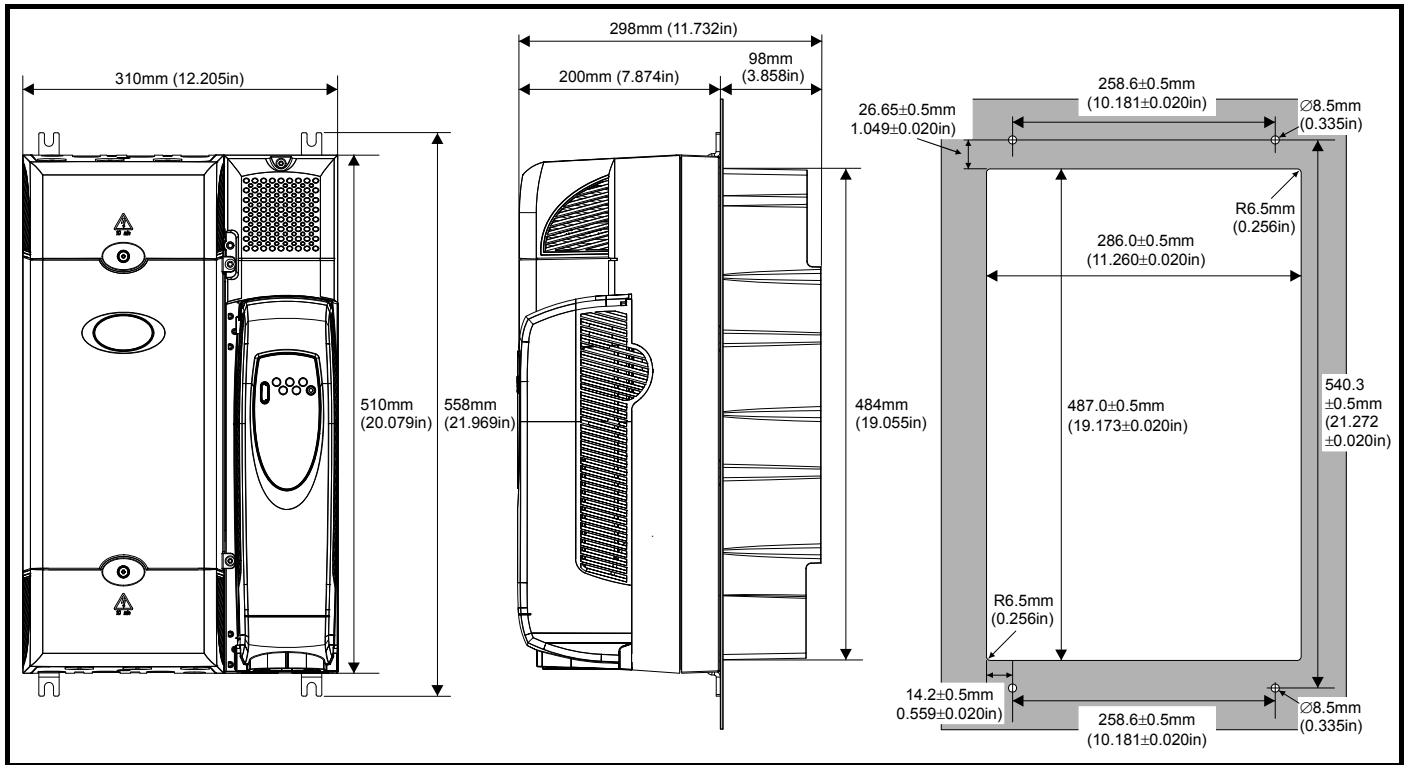
**Figure 5-12 Through-panel mounting of a size 3 drive**



**NOTE**

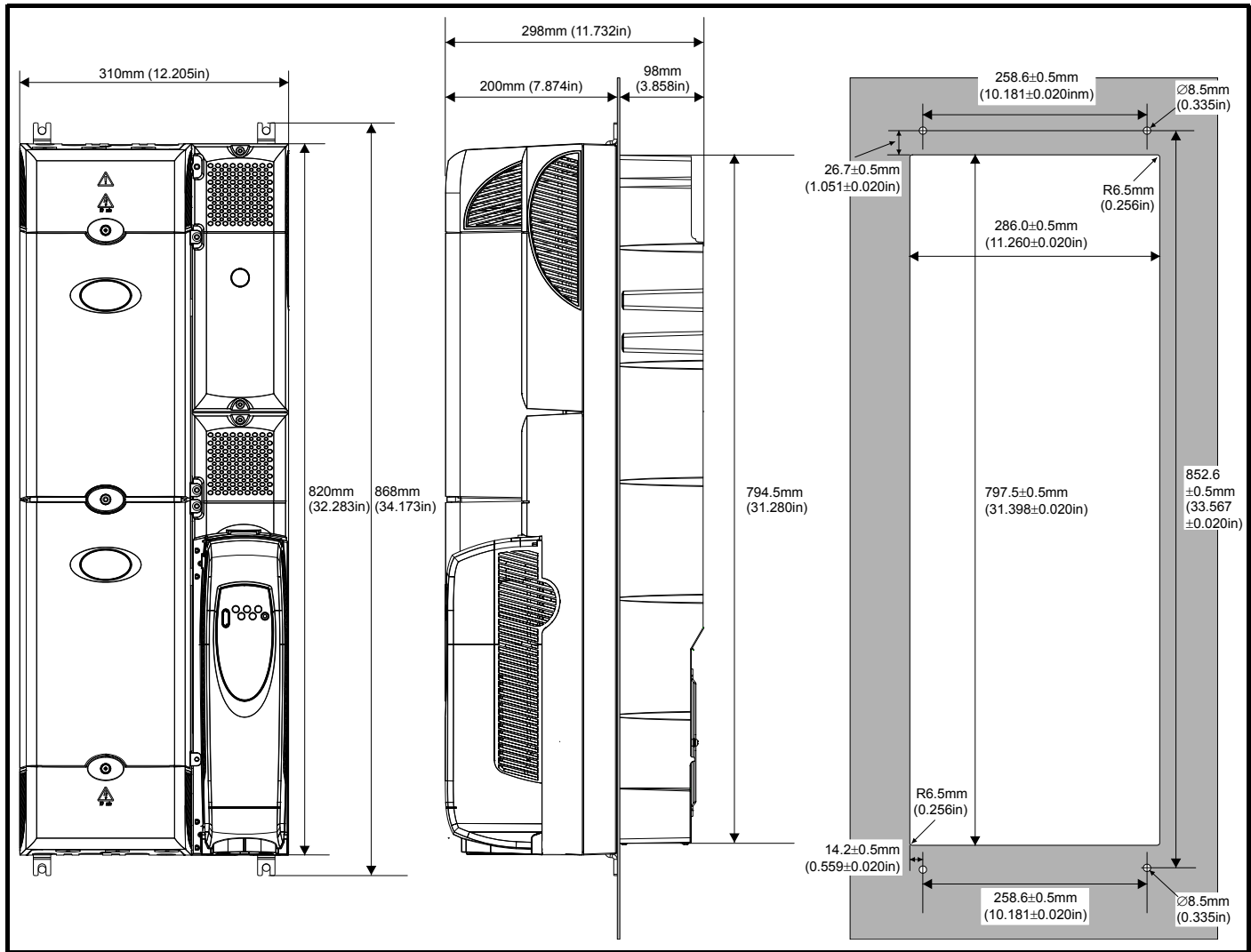
The control terminal cover must be removed on Commander SK sizes 2 and 3 to allow access to the mounting holes for through panel mounting.

**Figure 5-13 Through-panel mounting of a size 4 drive**



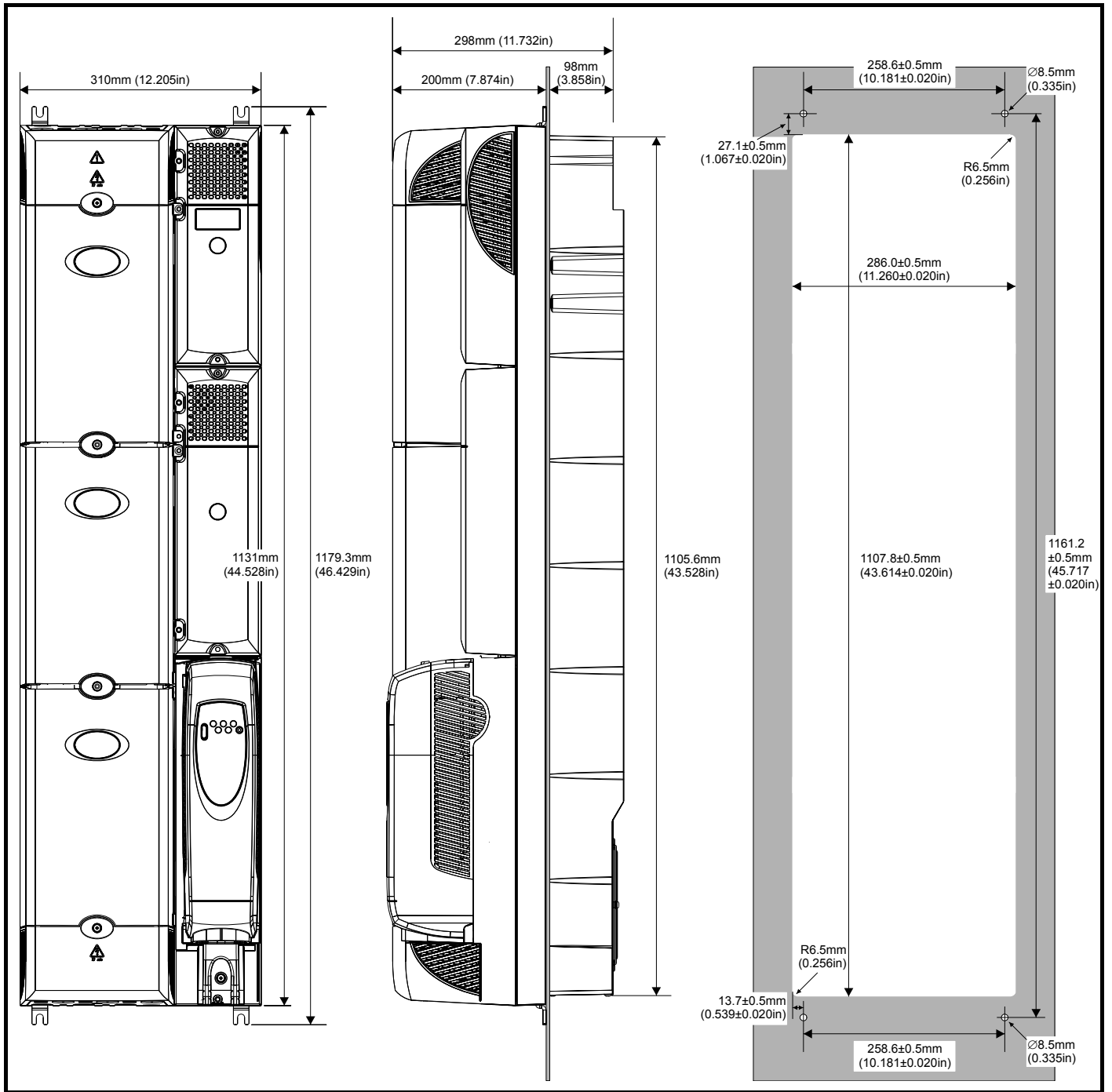
When a Commander SK size 4 or 5 is through-panel mounted, the grounding link bracket must be folded upwards. This is required to provide a grounding point for the grounding bracket. See section *Grounding hardware* on page 100 for details.

**Figure 5-14 Through-panel mounting of a size 5 drive**



When a Commander SK size 4 or 5 is through-panel mounted, the grounding link bracket must be folded upwards. This is required to provide a grounding point for the grounding bracket. See section *Grounding hardware* on page 100 for details.

**Figure 5-15 Through-panel mounting of a size 6 drive**



**NOTE**

In order to achieve IP54 rating and/or NEMA 12 for through-panel mounting, an IP54 insert must be installed (size 2) and the heatsink fan must be replaced with an IP54 rated fan (size 2 to 4). Additionally, the gasket provided should be installed between the drive and the backplate to ensure a good seal for the enclosure. See Figure 5-25 on page 61.

### 5.1.4 Mounting with Conduit Boxes

Figure 5-16 Size 2 drive with Conduit Box

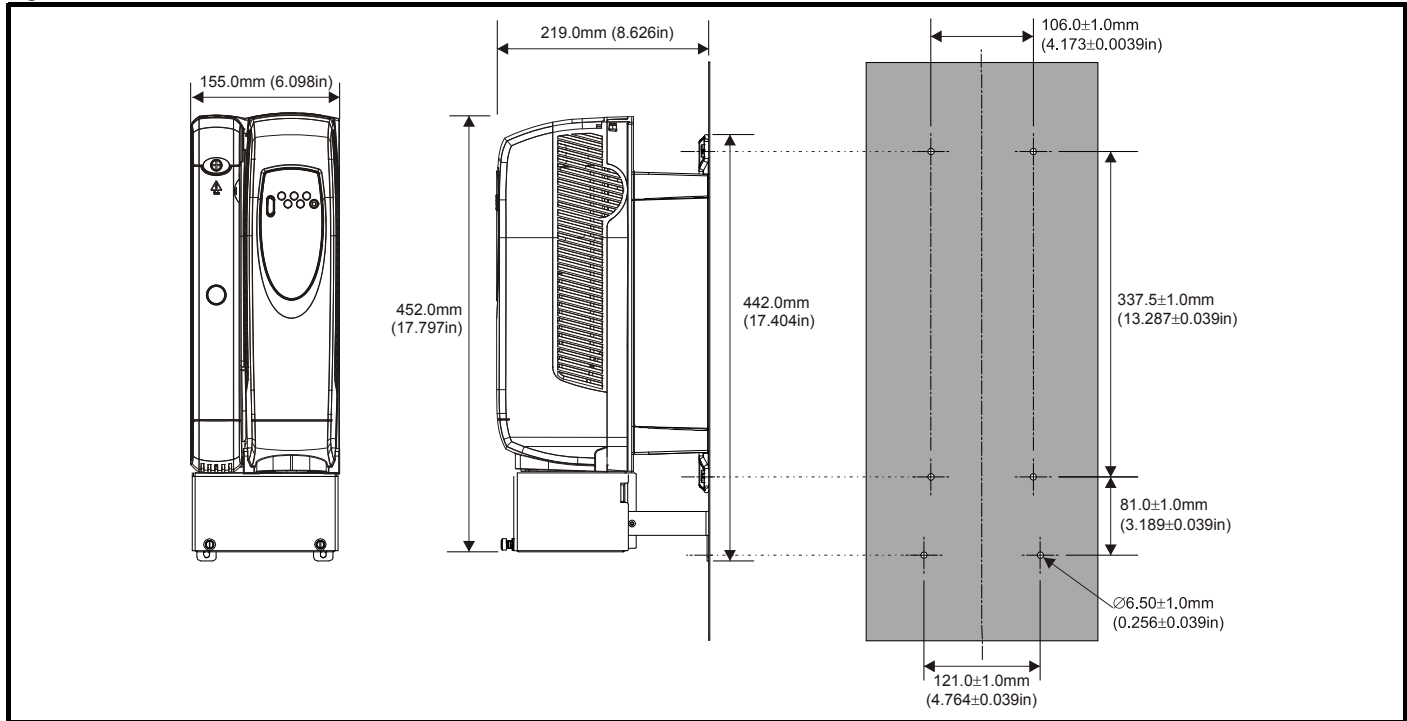
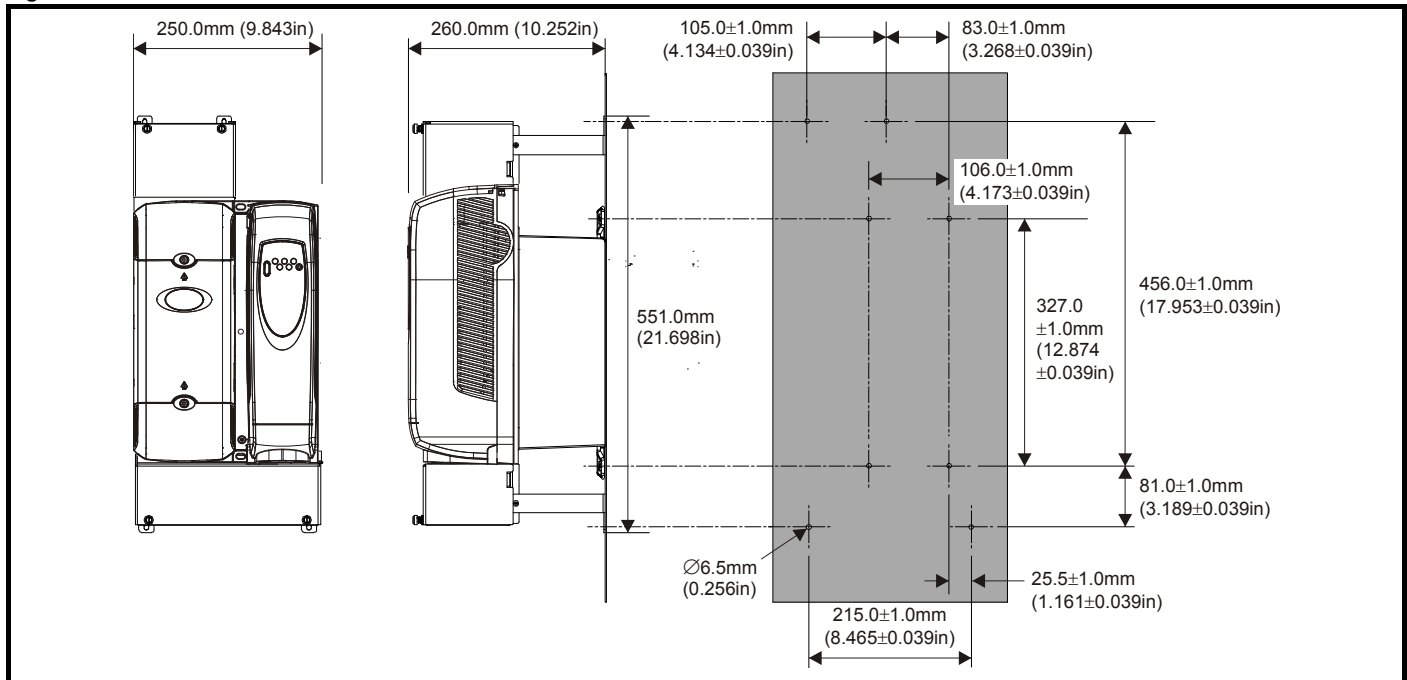
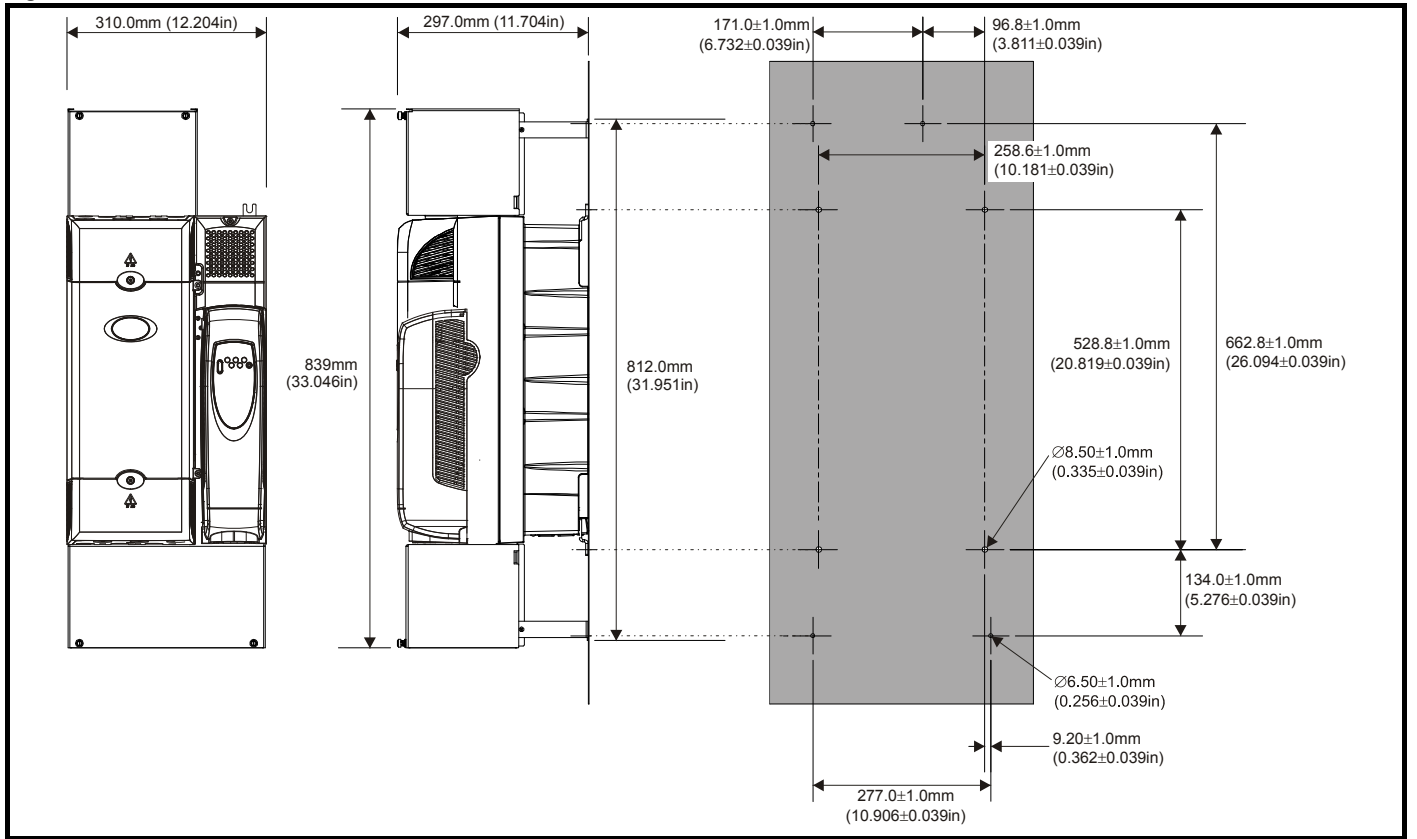


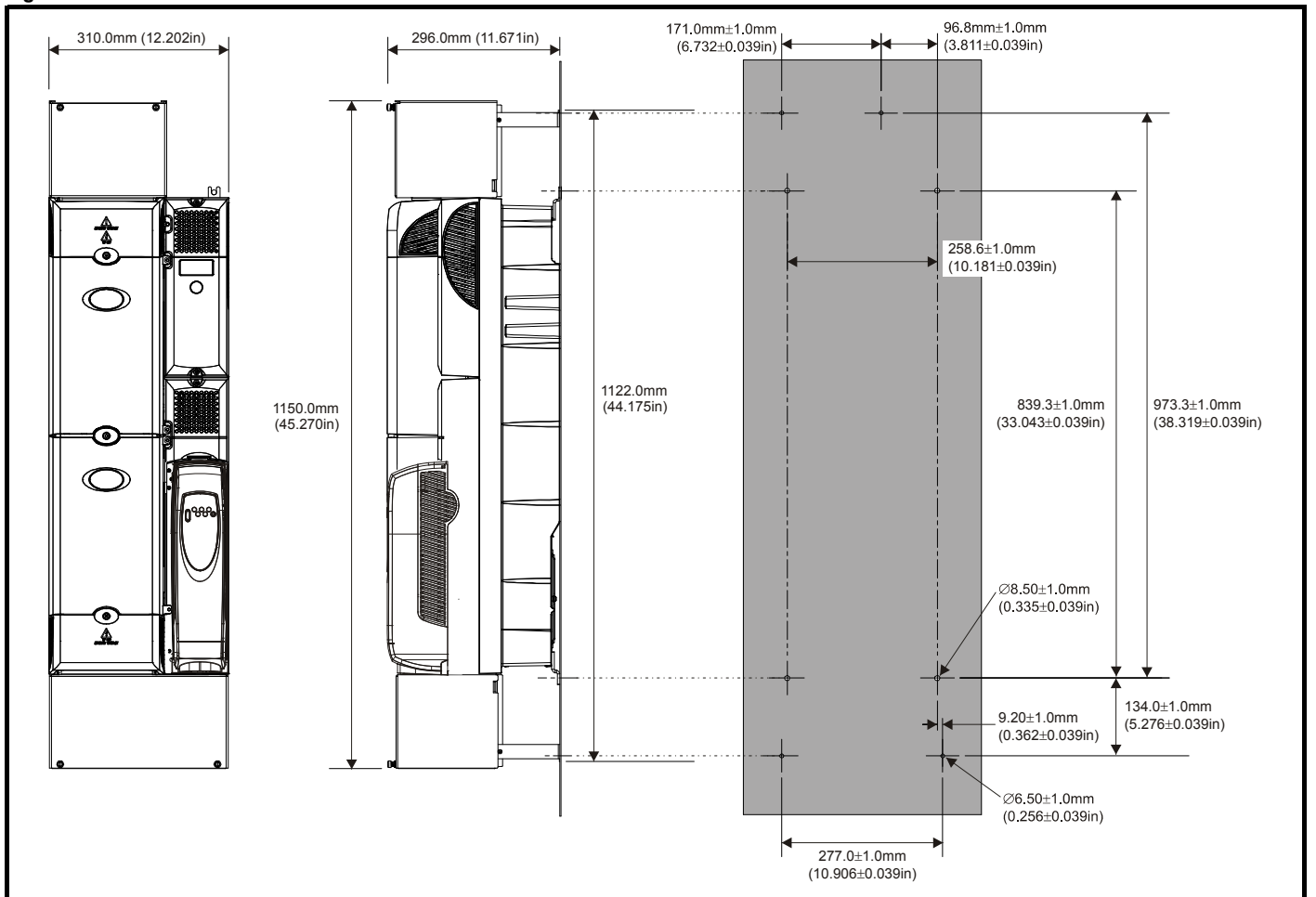
Figure 5-17 Size 3 drive with Conduit Box



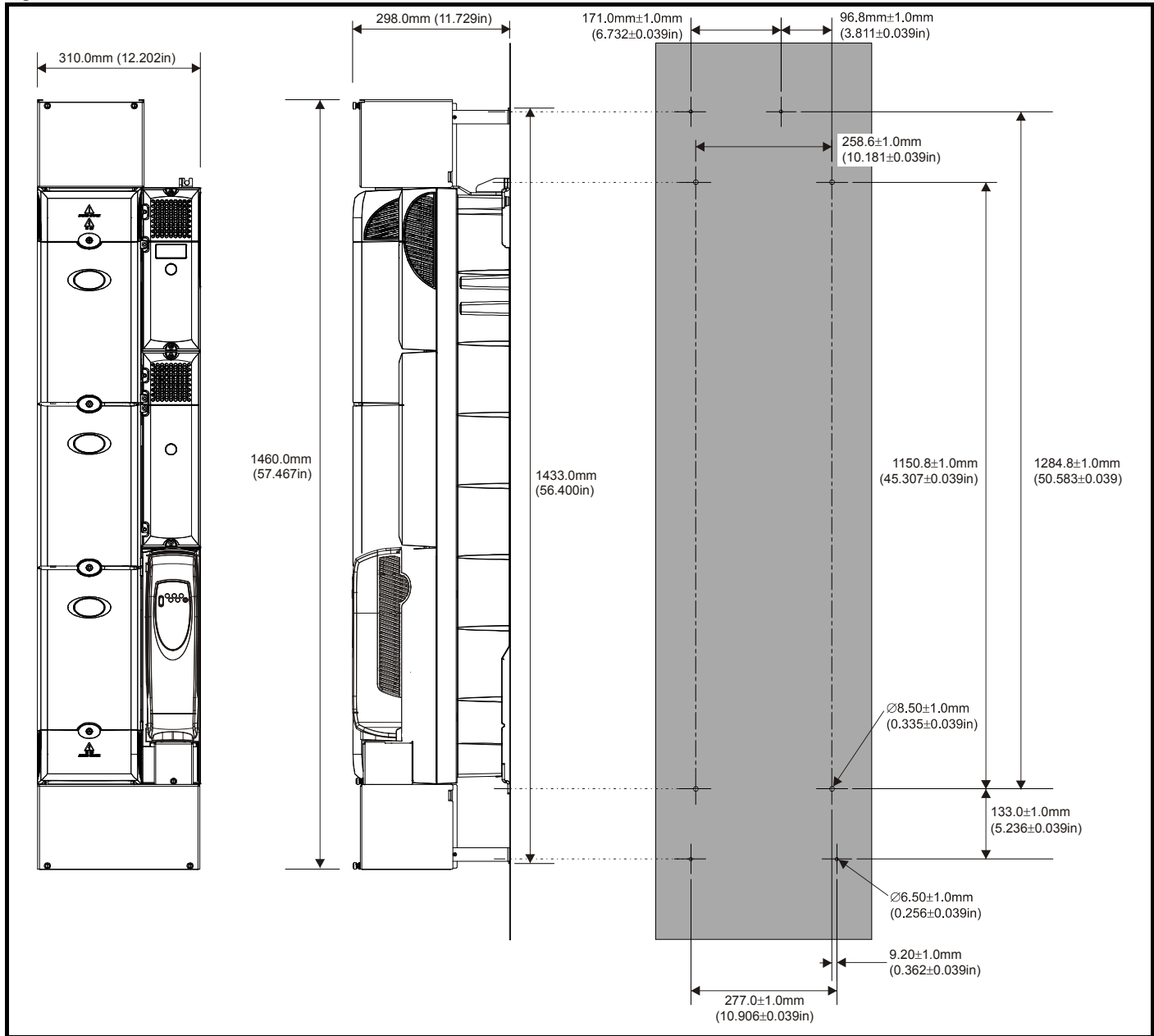
**Figure 5-18 Size 4 with Conduit Box**



**Figure 5-19 Size 5 with Conduit Box**

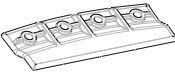

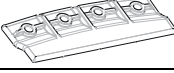





**Figure 5-20 Size 6 with Conduit Box**



## 5.1.5 Mounting brackets

Table 5-1 Mounting brackets

Model size	Surface	Through-panel	Hole size
2	 x2	 x1	6.5mm (0.256in)
3	 x2		
4	 x4		8.5mm (0.335in)
5 & 6	 x4		
	 x2		

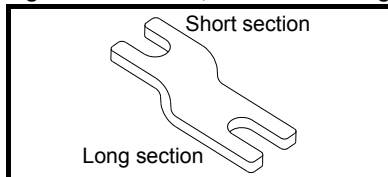
To avoid damaging the through-panel mounting bracket when through-panel mounting a size 2, the through-panel mounting bracket should be used to fix the top of the drive to the back plate **before** the bottom of the drive is fixed to the back plate. The tightening torque should be 4Nm (2.9 lb ft).

### Fitting of the Commander SK mounting brackets on size 4, 5 and 6

Commander SK size 4,5 and 6 use the same mounting brackets for surface and through-panel mounting.

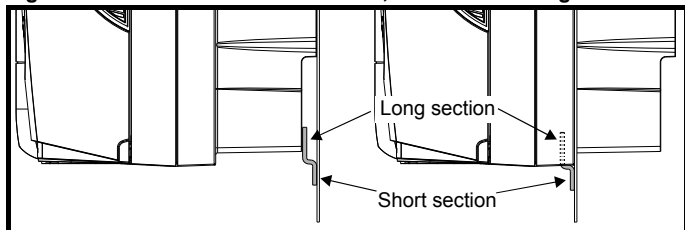
The mounting bracket has a long section and short section.

Figure 5-21 Size 4, 5 and 6 mounting bracket



The mounting bracket must be installed in the correct orientation with the long section inserted into or attached to the drive and the short section attached to the backplate. Figure 5-22 shows the orientation of the mounting bracket when the drive is surface mounted and through-panel mounted.

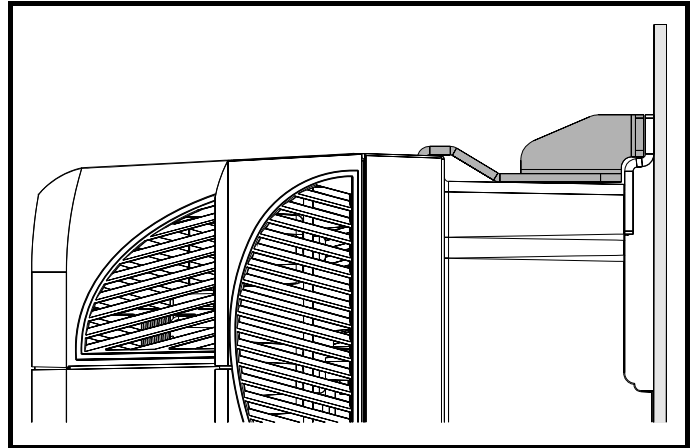
Figure 5-22 Orientation of the size 4, 5 and 6 mounting bracket



When through-panel mounted, the mounting brackets on the left hand side of the drive can be secured using the screws already located there. On the right hand side, the mounting brackets are just inserted into the slots in the chassis of the drive; no fixing screws are present here.

Commander SK size 5 and 6 also requires two top mounting brackets when the drive is surface mounted. The two brackets should be installed to the top of the drive as shown in Figure 5-23.

Figure 5-23 Location of top surface mounting brackets for size 5 and 6



The maximum torque setting for the screws into the drive chassis is 10Nm (7.4 lb ft).

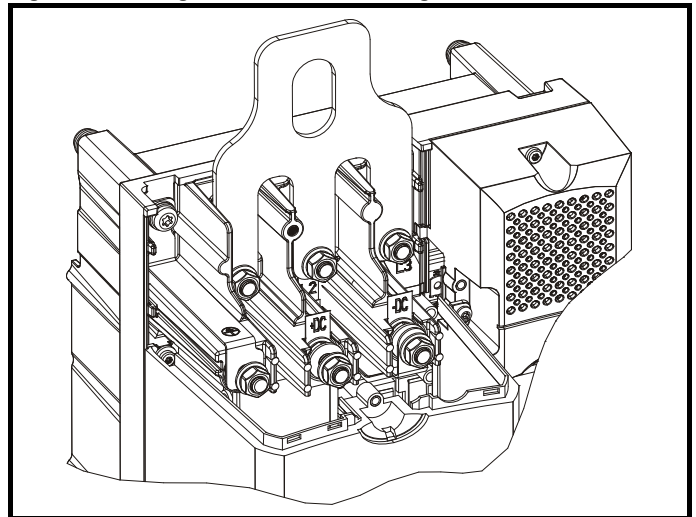
### 5.1.6 Large Commander SK lifting bracket

A lifting bracket for Commander SK sizes 4-6 modules is available (part number 6541-0073-00), which provides a safe lifting point to which a hoist may be attached when wall mounting these large drives.

Wall mounting of large SK drives has proved awkward due to the lack of a suitable lifting point with which to attach a hoist to.

The lifting bracket should only be attached to terminals L1, L2 and L3, as shown in figure 1 below. M10 terminals should then be retightened to 5 Nm minimum.

Figure 5-24 Large Commander SK lifting bracket



## 5.2 Enclosing standard drive for high environmental protection

An explanation of environmental protection rating is provided in section 9.6 *Environmental protection rating* on page 109.

The standard drive (Commander SK size 2 to 6) is rated to IP20 pollution degree 2 (dry, non-conductive contamination only), (NEMA 1). However, it is possible to configure the drive to achieve IP54 rating (UL Type 12 / NEMA 12) at the rear of the heatsink for through-panel mounting (some current derating is required for size 2). Refer to Table 2-21.

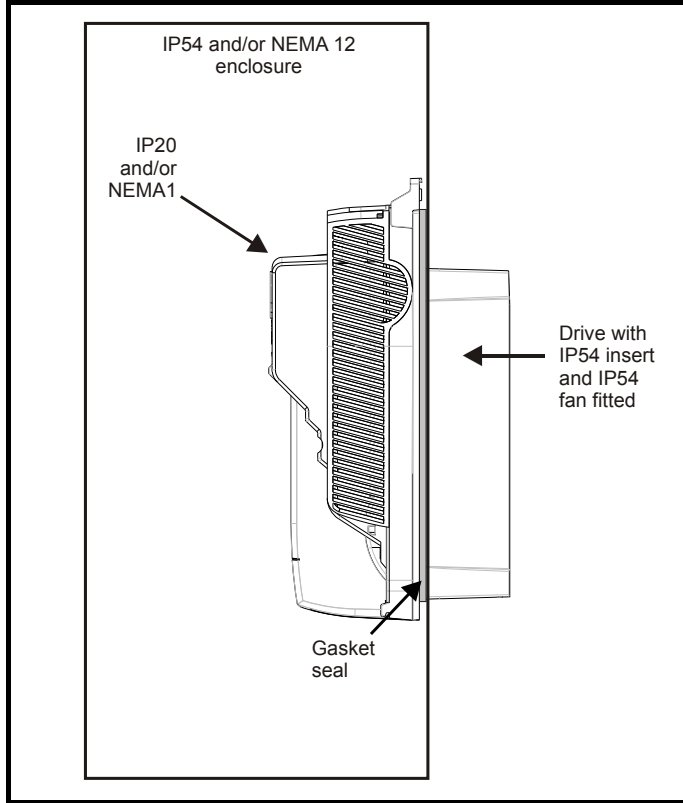
This allows the front of the drive, along with various switchgear, to be housed in an IP54 (UL Type 12 / NEMA 12) enclosure with the heatsink protruding through the panel to the external environment. Thus, the majority of the heat generated by the drive is dissipated outside the enclosure maintaining a reduced temperature inside the enclosure.



This also relies on a good seal being made between the heatsink and the rear of the enclosure using the gaskets provided.

**For Type 12 the drive must be mounted on a flat surface of a Type 12 enclosure.**

**Figure 5-25 Example of IP54 (UL Type 12 / NEMA 12) through-panel layout**



The main gasket should be installed as shown in Figure 5-26. Any screws / bolts that are used for mounting should be installed with the nylon washers provided in the kit box to maintain a seal around the screw hole. See Figure 5-28.

In order to achieve the high IP rating at the rear of the heatsink with size 2, it is necessary to seal a heatsink vent by installing the IP54 insert as shown in Figure 5-27.

For increased fan lifetime in a dirty environment the heatsink fan must be replaced with an IP54 fan.

**Table 5-2 Fan part numbers**

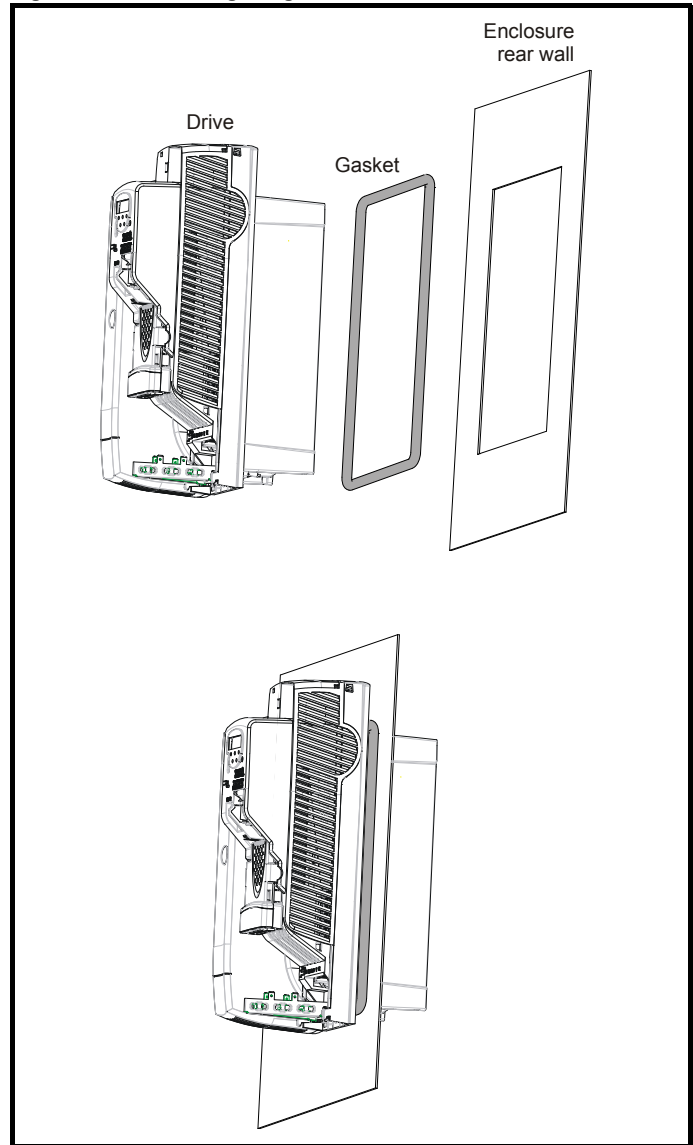
Frame size	IP54 fan part number	Number of fans
2	3251-3024-00	1
3	3251-4024-00	1
4	3251-7824-01	2

If the standard fan is used in a dirt/dusty environment, reduced fan lifetime will result. Regular cleaning of the fan and heatsink is recommended in this environment.

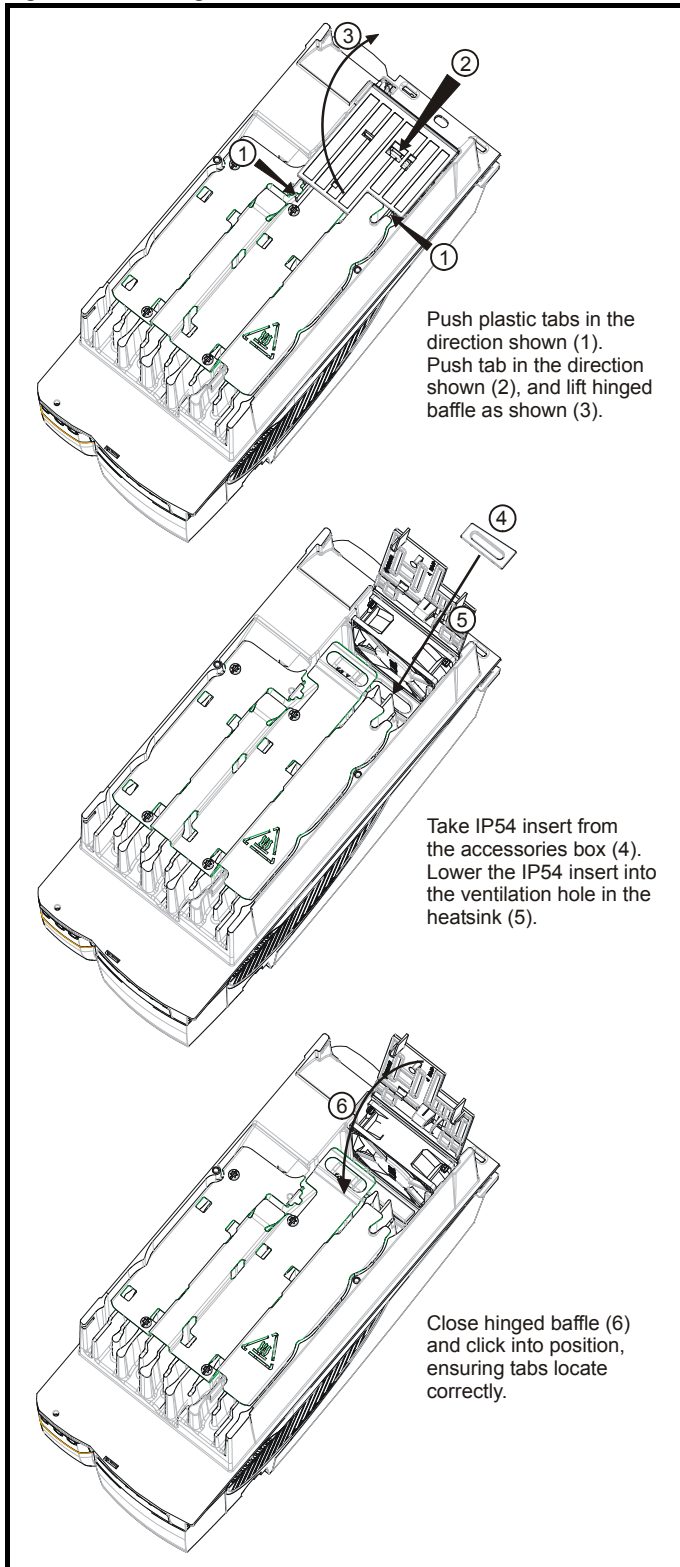
**Commander SK size 5 and 6**

When through hole mounted, the Commander SK size 5 and 6 are rated to IP54 and/or NEMA 12 as standard.

**Figure 5-26 Installing the gasket**



**Figure 5-27 Fitting of IP54 insert in Commander SK size 2**



In order to remove the IP54 insert, repeat steps (1) (2) and (3), reverse steps (5) and (4) and repeat step (6).

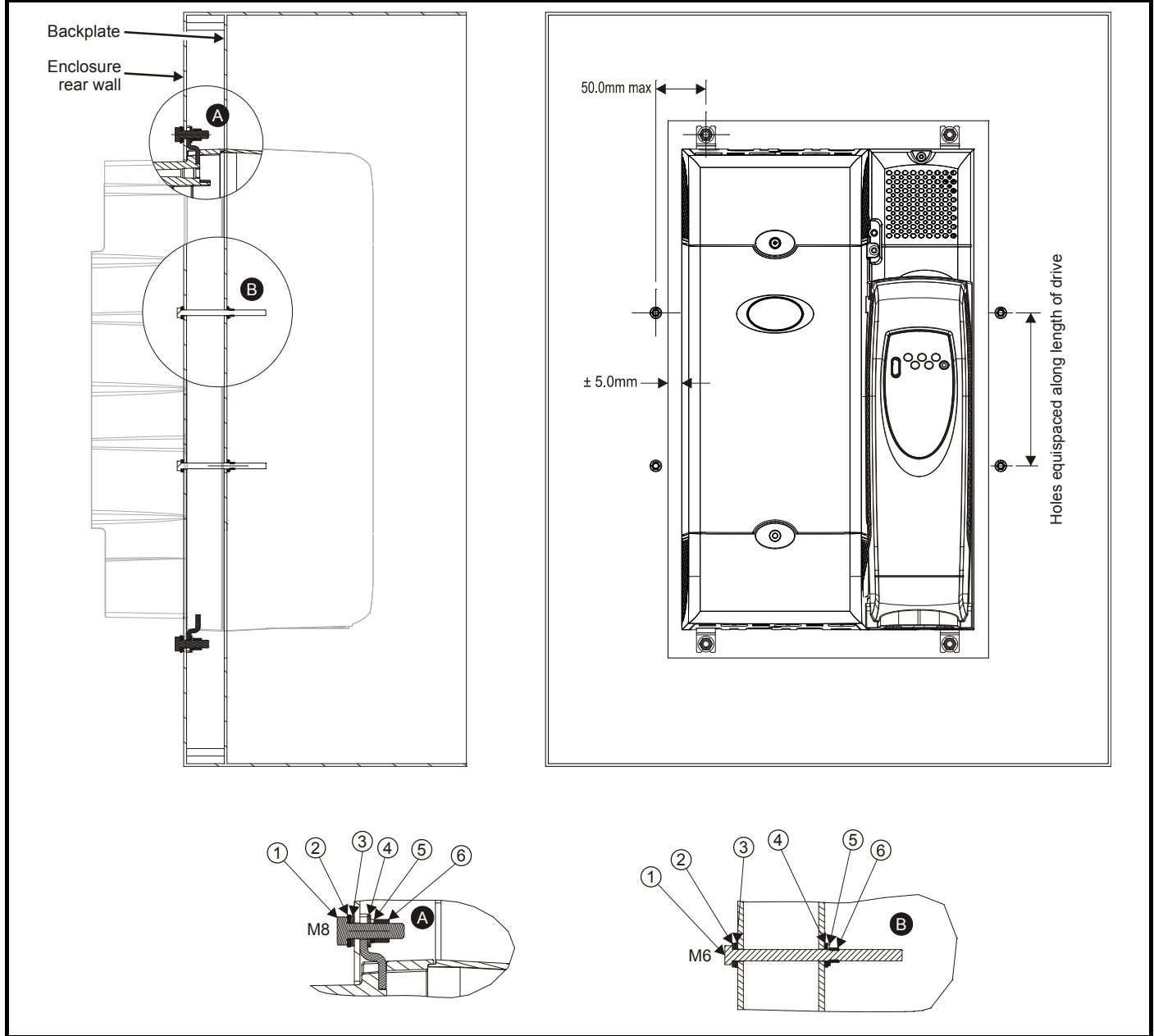
The IP54 fan can be installed at the same time as the IP54 insert. The connector on the existing fan should be unplugged from the power PCB. The existing fan then unclips from the black housing and can be removed. Once the new assembly is complete, the power lead of the new IP5X fan can then be pushed back through the heatsink and the grommet inserted in to the hole to ensure the correct seal is maintained. The fan is then clipped into the housing ensuring the blades rotate freely indicating that the fan is installed in the correct orientation.

For sizes 4 to 6 it may be necessary to improve the rigidity of the through panel mounting surface due to the larger distance between the top and bottom mounting brackets and the need to maintain compression on the gasket.

When the drive is mounted, if the gap between the drive flange (which the gasket rests on) and the rear wall of the enclosure is  $\geq 6\text{mm}$  at any point around the drive then the following methods can be used to compress the gasket further:

1. Use a thicker panel for the mounting wall of the enclosure through which the drive is mounted.
2. Use an internal backplate to pull the rear wall of the enclosure up to the drive gasket. See Figure 5-28 for details. (Nylon washers are supplied in the standard drive kit for sealing off any nut and bolt mountings that exit through the rear wall of the panel).
3. If an internal backplate is not available a separate clamp can be used to simulate option 2. See Figure 5-29. 4 off sealing clamps are supplied in the drive kit box.

**Figure 5-28 Option 2 for achieving IP54 (UL type 12 / NEMA 12) through-panel mounting**



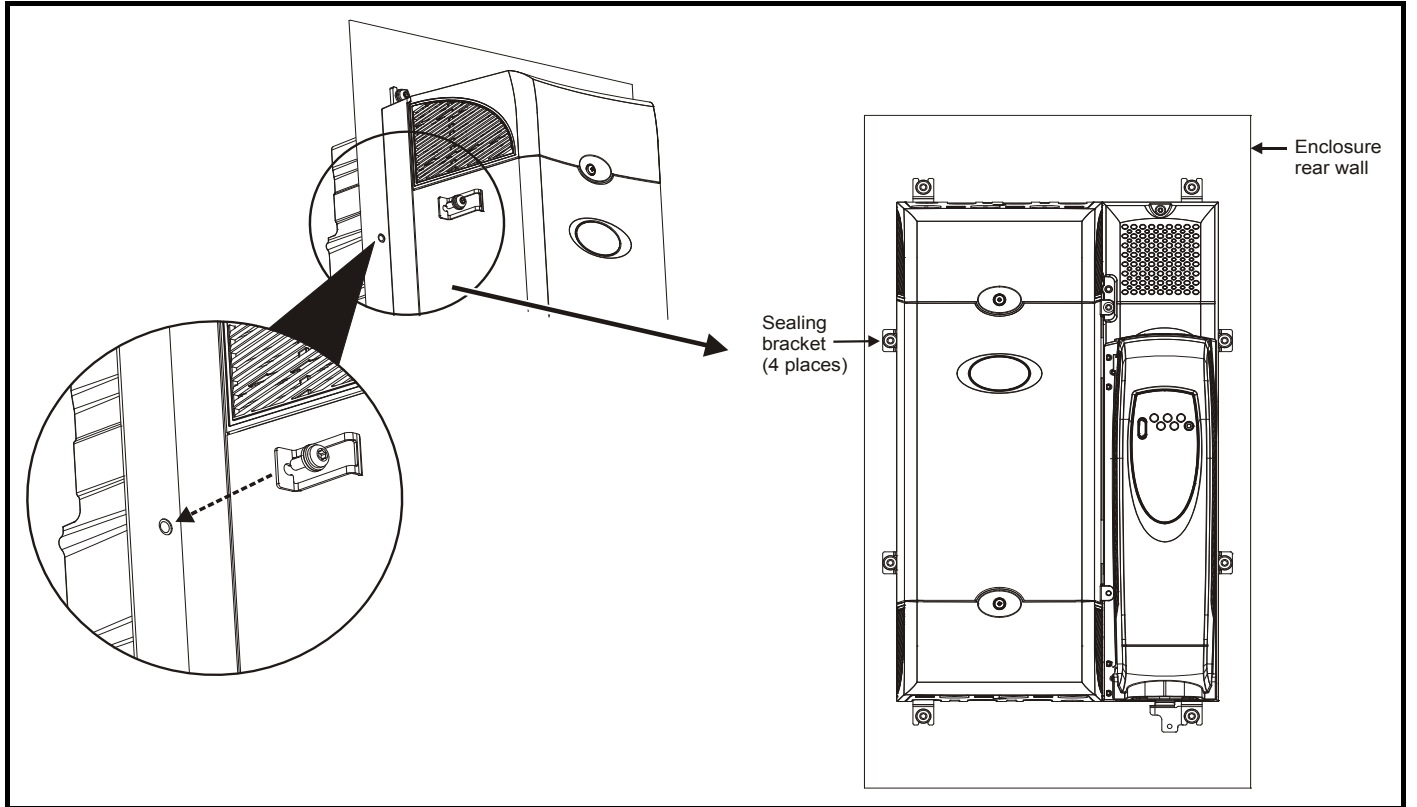
**Table 5-3 Description of mountings**

Item	Description
1	Bolt
2	Flat washer
3	Nylon washer (from kitbox)
4	Flat washer
5	Spring washer
6	Nut

**Table 5-4 Quantity of nylon washers supplied with the drive**

Size	Quantity of M8 (A)	Quantity of M6 (B)
2	0	3
3	0	4
4	4	4
5	4	4
6	4	4

**Figure 5-29 Option 3 for achieving IP54 (UL Type 12 / NEMA 12) through panel mounting**



**Table 5-5 Environmental considerations**

Environment	IP54 Insert	Fan	Comments
Clean	Not installed	Standard	
Dry and dusty (non-conductive)	Installed	Standard	Regular cleaning recommended. Fan lifetime may be reduced.
Dry and dusty (conductive)	Installed	Standard/ IP54	Regular cleaning recommended. Fan lifetime may be reduced.
IP54 compliance	Installed	IP54	Regular cleaning recommended.

**Through-panel mounting losses**

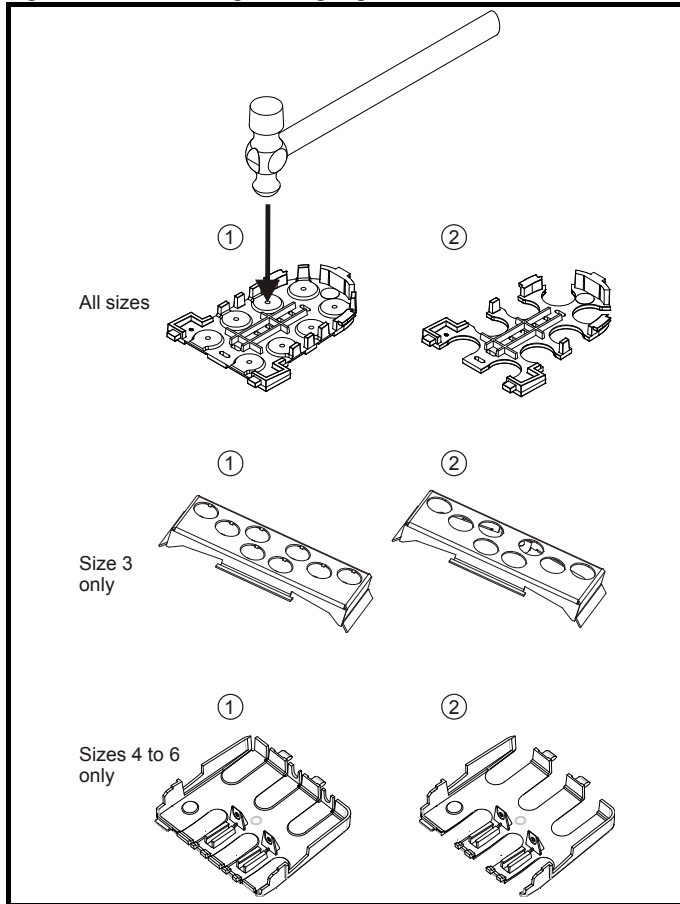
When designing an IP54 and/or NEMA 12 enclosure, the losses from the front of the drive must be taken into consideration.

**Table 5-6 Through-panel mounting losses**

Frame size	Power loss (W)
2	≤75
3	≤100
4	≤204
5	≤347
6	≤480

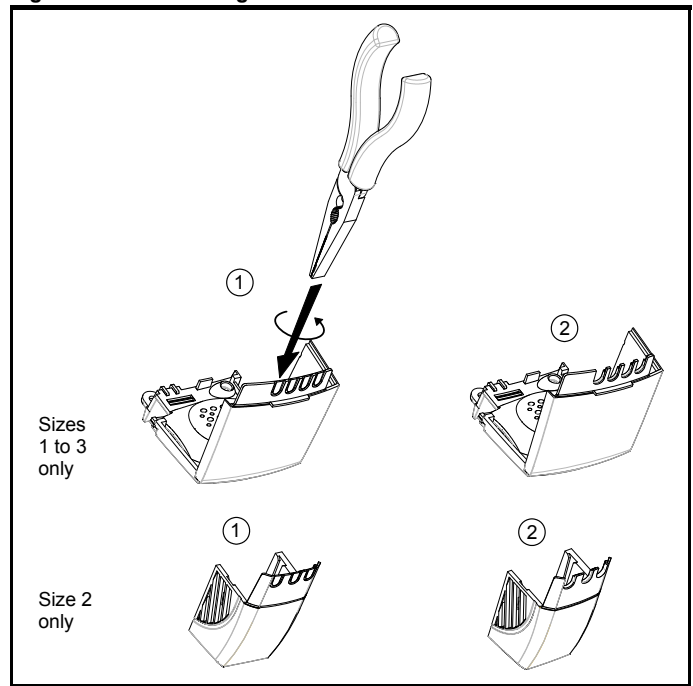
### 5.2.1 Removing the finger-guard and DC terminal cover break-outs

**Figure 5-30 Removing the finger-guard break-outs**



Place finger-guard on a flat solid surface and hit relevant break-outs with hammer as shown (1). Continue until all required break-outs are removed (2). Remove any flash / sharp edges once the break-outs are removed.

**Figure 5-31 Removing the DC terminal cover break-outs**

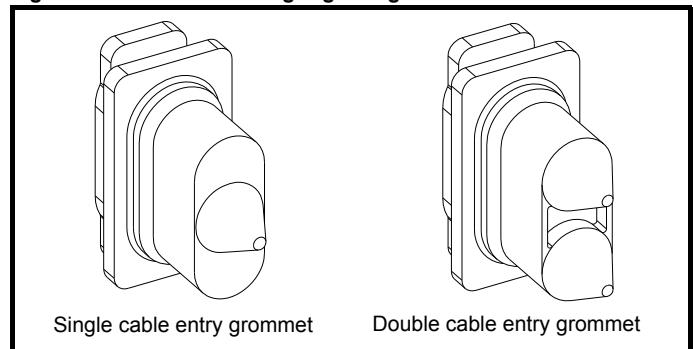


Grasp the DC terminal cover break-outs with pliers as shown (1) and twist to remove. Continue until all required break-outs are removed (2).

Remove any flash / sharp edges once the break-outs are removed. Use the DC terminal cover grommets supplied in the accessory box to maintain the seal at the top of the drive.

Grommets are available for the size 4 to 6 finger-guards. Two versions are available allowing for either single or double cable entries. These are not required if the optional conduit box is installed.

**Figure 5-32 Size 4 to 6 finger-guard grommets**



The grommets are available as a kit of four grommets under the following part numbers:

9500-0074 Kit of four single entry grommets

9500-0075 Kit of four double entry grommets

If the break-outs are removed from the finger-guard, then the grommets are required for Commander SK size 4 to 6 to meet the IP20 standard.

## 5.2.2 UL Type 1 kit

Figure 5-33 UL Type 1 kit

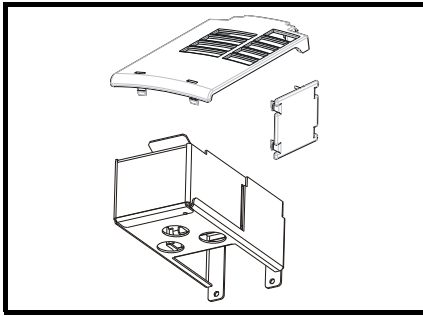


Table 5-7 UL Type 1 kit part numbers

Frame size	Part number
A	9500-0079
B	9500-0080
C	9500-0081
D	9500-1002

UL Type 1 kit required for Commander SK size A to D to meet NEMA 1 and UL Type 1.

## 5.2.3 Conduit connection boxes

Conduit connection boxes are available as an option. Figure 5-34 demonstrates a conduit connection box installed on a size 4 standard drive.

For further information, refer to section 5.1 *Mounting methods* on page 44.

Figure 5-34 Size 4 standard drive with conduit connection box installed

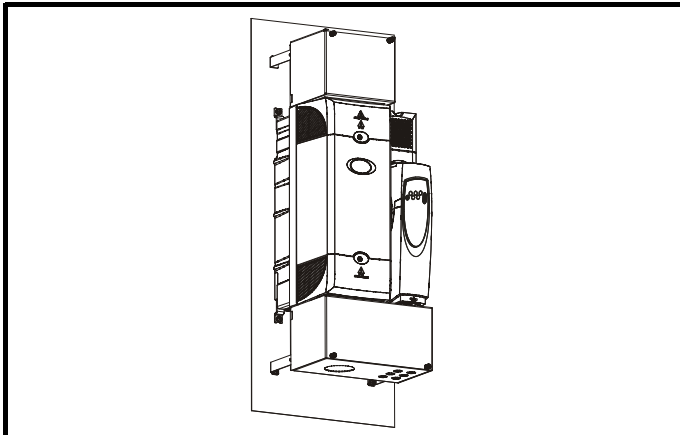


Table 5-8 Conduit box part numbers

Frame size	Top conduit box	Bottom conduit box
2		6500-0011
3	6500-0033*	6500-0014
4	6500-0017	6500-0018
5	6500-0023	6500-0024
6	6500-0027	6500-0028

\*For DC or brake connections only.

The conduit boxes and warning label (3661-0045-01) are required for the size 2 to 6 to meet the requirements of UL Type 1.

## 5.2.4 Electrical terminals layout

Figure 5-35 Size A power terminal connections

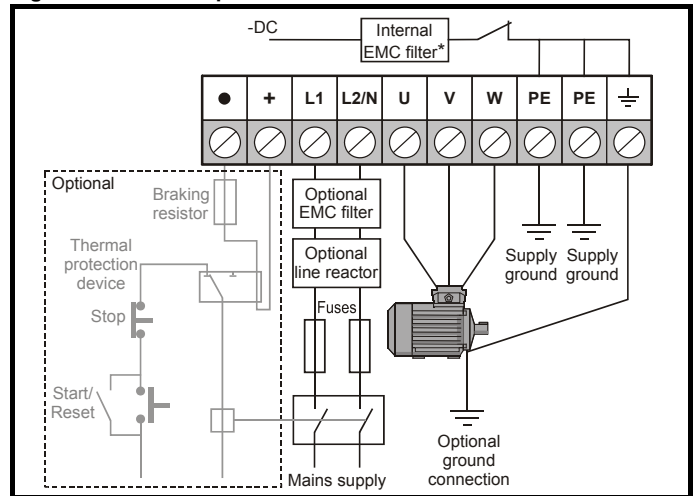
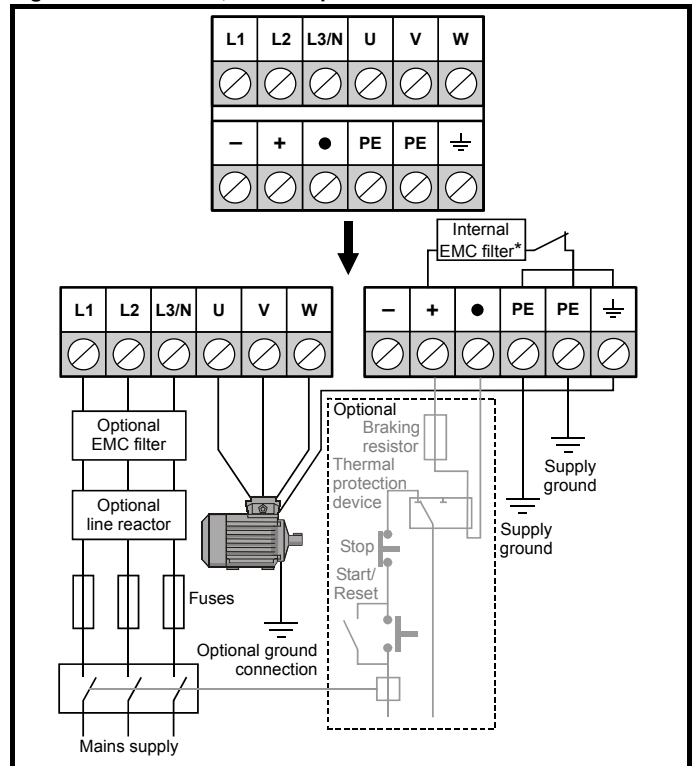


Figure 5-36 Sizes B, C and D power terminal connections



### NOTE

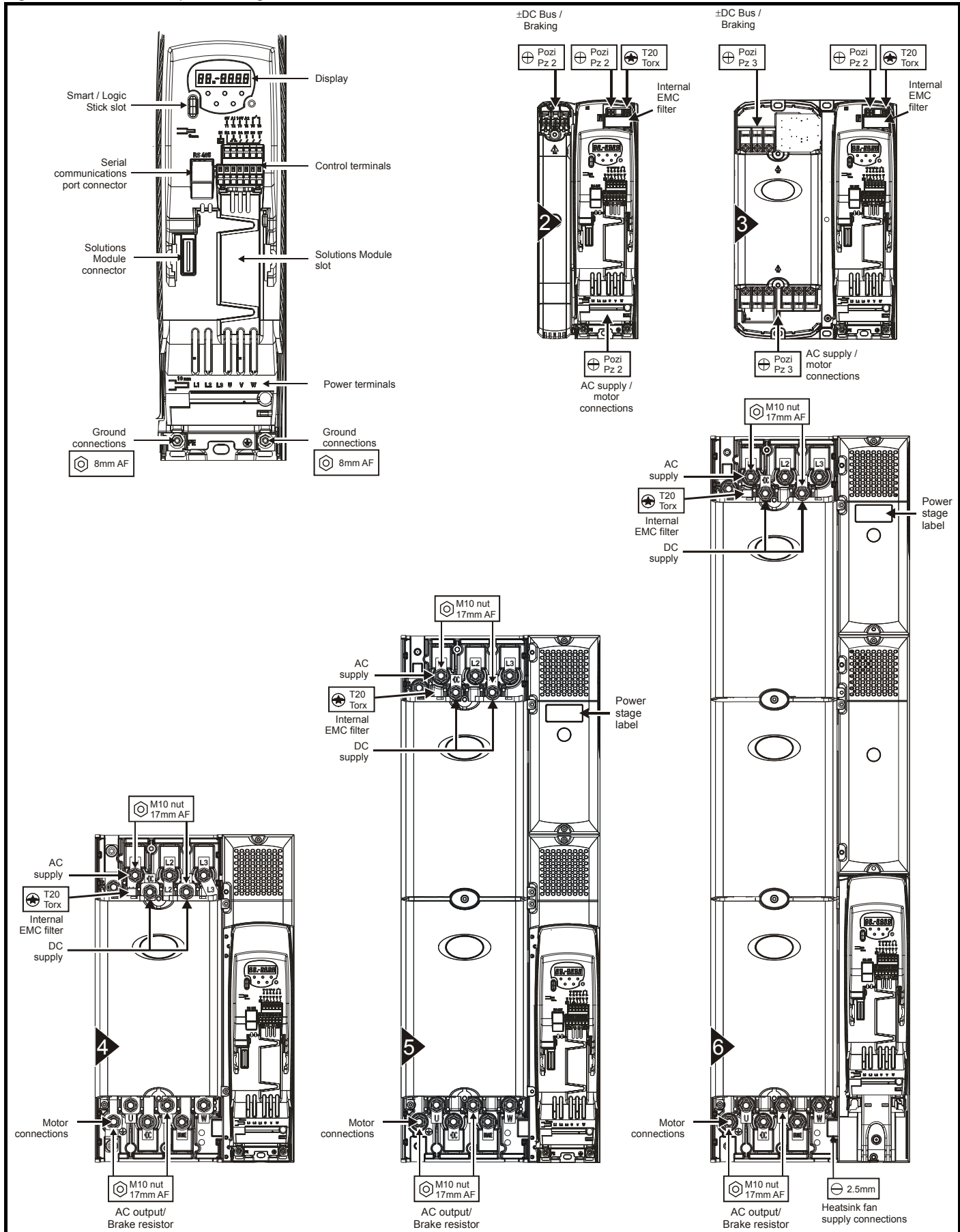
The braking terminals are not available on size A 110V drives.

On the Commander SKB 110V drives, the supply should be connected to L1 and L3/N.

### NOTE


On the Commander SKB 110V drives, the -DC bus terminal has no internal connection.

**Figure 5-37 Location of power and ground terminals**





## Terminal sizes and torque settings

 To avoid a fire hazard and maintain validity of the UL Listing, adhere to the specified tightening torques for the power and ground terminals. Refer to the following tables.

**WARNING**

Resistor part number: 1220-2758-01

Each kit contains the following parts:

- A braking resistor assembly
- A through-panel grommet
- A wire clip
- An installation sheet


**Table 5-9 Drive control and relay terminal data**

Model	Connection type
All	Spring terminals


**Table 5-10 Drive power terminal data**

Model size	AC terminals	DC and braking terminals	Ground terminals
A	0.5Nm (4.4 lb in)		
B, C and D	1.4Nm (12.1 lb in)		
2	Plug-in terminal block 1.5Nm (1.1 lb ft)	Terminal block (M5 screws) 1.5Nm (1.1 lb ft)	M5 stud 4.0Nm (2.9 lb ft)
3	Terminal block (M6 screws) 2.5Nm (1.8 lb ft)		6.0Nm (4.4 lb ft)
4	M10 stud 15Nm (11.1 lb ft)		M10 stud 12Nm (8.8 lb ft)
5			
6			
Torque tolerance			±10%

### 5.2.5 Heatsink mounted braking resistor

 If the drive has been used at high load levels for a period of time, the heatsink and heatsink mounted braking resistor can reach temperatures in excess of 70°C (158°F). Human contact with the heatsink and heatsink mounted braking resistor should be prevented.

**WARNING**

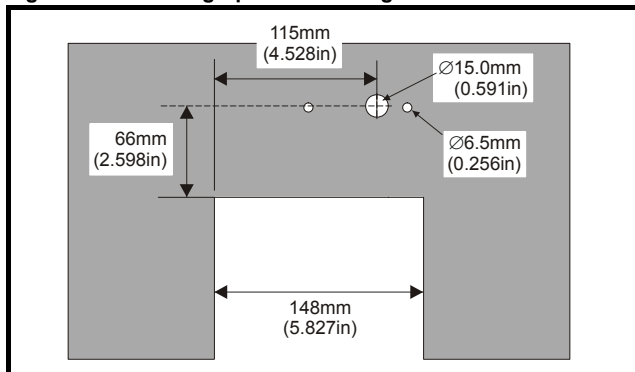
 To avoid the risk of fire when the drive is surface mounted with the braking resistor installed, the back plate should be a non-flammable material.

**WARNING**

The Commander SK size 2 has been designed with an optional space-saving heatsink mounted resistor. The resistor can be installed within the heatsink fins of the drive. When the heatsink mounted resistor is used, an external thermal protection device is not required as the resistor is designed such that it will fail safely under fault conditions. The built-in software overload protection should be set-up to protect the resistor. The resistor is rated to IP54 and/or NEMA 12.

If the drive is to be through-panel mounted with the heatsink mounted brake resistor installed, then the aperture in the panel through which the drive is mounted must be modified as shown in Figure 5-38. This is in order to allow for the braking resistor cables and grommets.

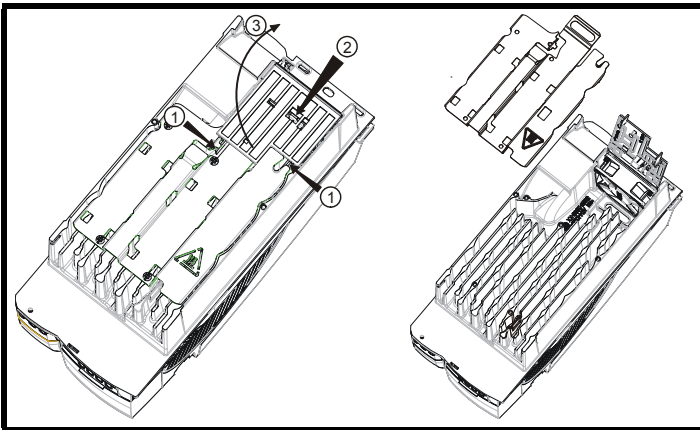
**Figure 5-38 Through-panel mounting cut out details for size 2**





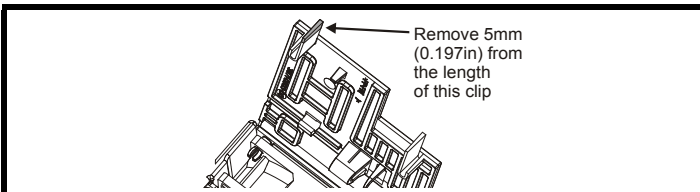
## Size 2 Braking resistor fitting instructions

**Figure 5-39 Removing the baffle plate on a size 2**



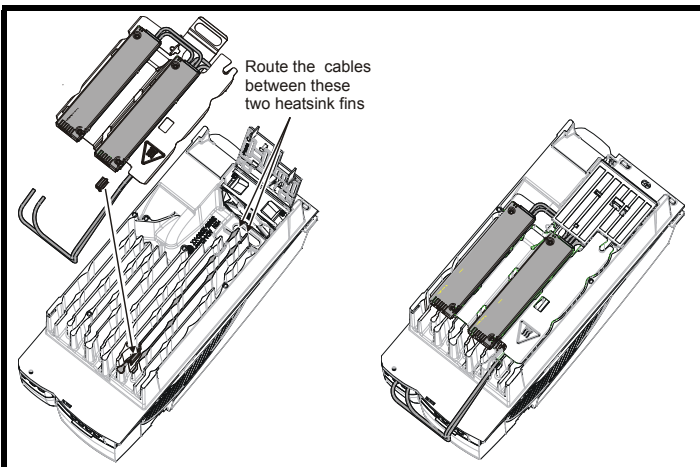
- Remove the DC cover as detailed in Menu 3 in the *Commander SK size 2 to 6 Getting Started Guide*.
- Remove the 2 breakouts that line-up with the BR and +DC terminal connections as detailed in Menu 3 in the *Commander SK size 2 to 6 Getting Started Guide*.
- Lift the hinged baffle plate by pushing the plastic tabs in the direction shown (1). Push tab in the direction shown (2), and lift the baffle as shown (3).
- Remove the baffle plate by removing the two screws. These two screws are no longer required.

**Figure 5-40 Modifying the fan baffle on a size 2**



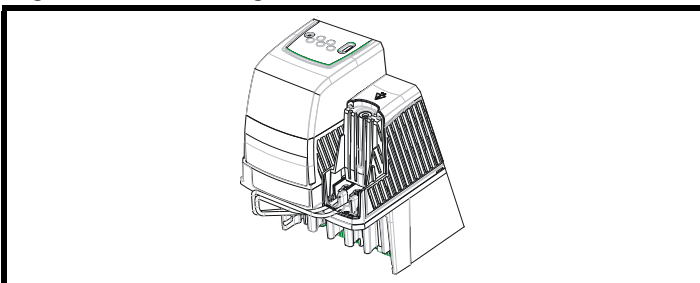
- Remove 5mm (0.197in) from the length of the clip on the plastic fan baffle.

**Figure 5-41 Fitting the heatsink mounted braking resistor on a size 2**



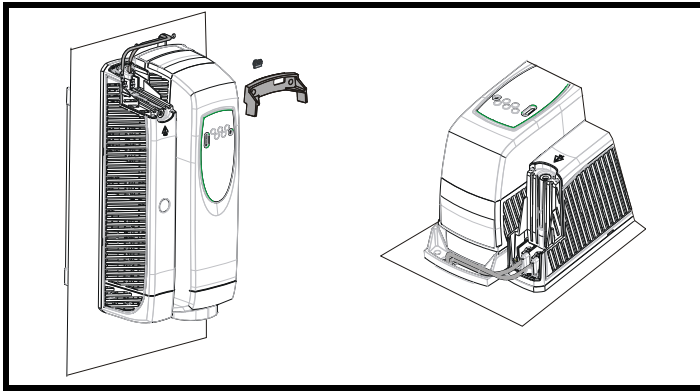
- Fit clip to heatsink in the position shown in diagram opposite. Route the long cables of the resistor assembly between the fins of the heatsink as shown in Figure 5-41.
- Fit the heatsink baffle plate in place with the cables routed underneath. Ensure the cables are not trapped between a heatsink fin and the baffle plate.
- Fit the braking resistors to the heatsink. The resistors are installed with captive screws.
- The screws should be tightened to a maximum torque of 2.0 N m (1.5 lb ft).
- Close the hinged fan baffle.
- Fit cables to heatsink clip.

**Figure 5-42 Connecting the brake resistor on a surface mounted size 2**



- Fit the DC terminal cover grommets supplied in the accessory box with the drive, to the cables. To ensure a good seal, the grommets are a tight fit. Lubrication may be required to help fit the grommets to the cables.
- Terminate the cables with suitable crimps and connect to the BR and DC2 terminals.
- Replace the terminal cover.

**Figure 5-43 Connecting the brake resistor on a through-panel mounted size 2**



- See Figure 5-38 for through-panel mounting cut-out details.
- Pass the cables through the hole in the panel and fit the hole grommet.
- Fit the mounting bracket.
- Fit the DC terminal cover grommets supplied in the accessory box with the drive, to the cables. To ensure a good seal, the grommets are a tight fit. Lubrication may be required to help fit the grommets to the cables.
- Terminate the cables with suitable crimps and connect to the BR and DC2 terminals.
- Replace the terminal cover.



**Braking resistor overload protection parameter settings**

**Failure to observe the following information may damage the resistor.**

The *Commander SK* software contains an overload protection function for a braking resistor. On *Commander SK* size 2 this function should be enabled to protect the heatsink mounted resistor. Below are the parameter settings.

Parameter		200V drive	400V drive
Full power braking time	Pr <b>10.30</b>	0.09	0.02
Full power braking period	Pr <b>10.31</b>	2.0	

For more information on the braking resistor software overload protection, see the *Commander SK Advanced User Guide*.

If the heatsink mounted braking resistor is to be used at more than half of its average power rating then the drive's cooling fan must be set to full speed by setting Pr **6.45** to On (1).

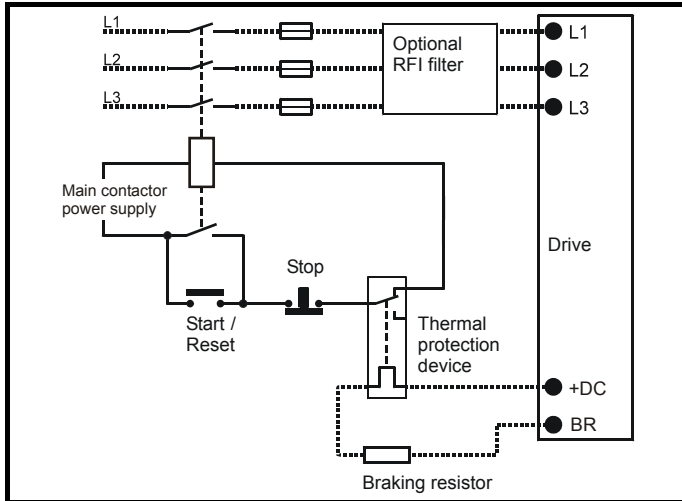


**Braking resistor: High temperatures and overload protection**

Braking resistors can reach high temperatures. Locate braking resistors so that damage cannot result. Use cable having insulation capable of withstanding the high temperatures.

It is essential that the braking resistor be protected against overload caused by a failure of the brake control. Unless the resistor has built in protection, the circuit below should be used, where the thermal protection device disconnects the AC supply to the drive.

**Figure 5-44 Typical protection circuit for a braking resistor**



(86°F) ambient, the average power rating is 100W for size 2. The previous parameter settings ensure this is the case.

*Commander SK* size 3 and larger do not have heatsink mounted braking resistors, hence the default values of Pr **10.30** and Pr **10.31** are 0 (i.e. software braking resistor overload protection disabled).

**Braking resistor software overload protection**

The *Commander SK* software contains an overload protection function for a braking resistor. In order to enable and set-up this function, it is necessary to enter two values into the drive:

- Resistor short-time overload time (Pr **10.30**)
- Resistor minimum time between repeated short-time overloads (Pr **10.31**)

This data should be obtained from the manufacturer of the braking resistors.

Pr **10.39** gives an indication of braking resistor temperature based on a simple thermal model. Zero indicates the resistor is close to ambient and 100% is the maximum temperature the resistor can withstand. A br.rS alarm is given if this parameter is above 75% and the braking IGBT is active. An It.br trip will occur if Pr **10.39** reaches 100%, when Pr **10.37** is set to 0 (default value) or 1.

If Pr **10.37** is equal to 2 or 3 an It.br trip will not occur when Pr **10.39** reaches 100%, but instead the braking IGBT will be disabled until Pr **10.39** falls below 95%. This option is intended for applications with parallel-connected DC buses where there are several resistors, each of which cannot withstand full DC bus voltage continuously. With this type of application it is unlikely the braking energy will be shared equally between the resistors because of voltage measurement tolerances within the individual drives. Therefore with Pr **10.37** set to 2 or 3, then as soon as a resistor has reached its maximum temperature the drive will disable the braking IGBT, and another resistor on another drive will take up the braking energy. Once Pr **10.39** has fallen below 95% the drive will allow the braking IGBT to operate again.

**Table 5-11 Heatsink mounted braking resistor data**

Parameter	Size 2
Part number	1220-2758-01
DC resistance at 25°C	37.5Ω
Peak instantaneous power over 1ms at nominal resistance	16kW
Average power over 60s*	100W
Ingress Protection (IP) rating	IP54
Maximum altitude	2000m

\* To keep the temperature of the resistor below 70°C (158°F) in a 30°C

See the *Commander SK Advanced User Guide* for more information on Pr 10.30, Pr 10.31, Pr 10.37 and Pr 10.39.

This software overload protection should be used in addition to an external overload protection device.

### 5.3 Sizing a braking resistor

The size and rating of the resistor are calculated with respect to the energy to be absorbed, the rate at which the power is delivered and the time between successive decelerations.

Kinetic energy of the motor and the driven machine =  $0.5 J \omega^2$

Where:

$\omega$  = angular velocity in radians  $s^{-1}$

$$\omega = \frac{2\pi \times n}{60}$$

Where:  $n$  = motor speed in RPM

$J$  = total moment of inertia (kg  $m^2$ ) of the motor and driven machine. If there is gearing between the motor and the machine,  $J$  is the value reflected at the motor shaft.

As energy is proportional to the square of the angular velocity, most of the energy is concentrated at the higher operating speeds. If the motor is operated above base speed, the power delivered to the resistor is constant until the speed falls below base speed.

#### Example

The information required to calculate the size of the braking resistor is as below:

Inertia	$J$	2kg $m^2$
Braking cycle		10 seconds in every 60 seconds
Time required to decelerate to stop	$t_b$	10 seconds
Motor size		4kW
Drive size		4kW
Motor nominal torque		26Nm
Motor rated speed	$n$	1450RPM
Braking transistor operating voltage	$V$	780VDC

The first stage is to determine the maximum braking torque ( $M$ ) available.

$$\begin{aligned} M &= 150\% \times \text{nominal motor torque} \\ &= 1.5 \times 26 \\ &= 39\text{Nm} \end{aligned}$$

Now calculate the minimum deceleration time possible to ensure that the time required is within specification.

$$M = J \times \alpha$$

Where:

$\alpha$  = angular acceleration (rad /  $s^2$ )

$J$  = moment of inertia (kg  $m^2$ )

$$\alpha = \frac{\omega}{t_b}$$

$$= J \times \frac{\omega}{t_b}$$

Where:

$\omega$  = angular velocity (rad / s)

$t_b$  = minimum deceleration time (s)

$$\omega = \frac{2 \times \pi \times n}{60}$$

$n$  = motor speed RPM

$$= \frac{J \times \pi \times n}{30 \times t_b}$$

$$= \frac{2 \times \pi \times 1450}{30 \times t_b}$$

$$39 = \frac{2 \times \pi \times 1450}{30 \times t_b}$$

$$t_b = \frac{2 \times \pi \times 1450}{30 \times 39}$$

$$t_b = 7.8 \text{ seconds}$$

The minimum time for deceleration is 7.8 seconds. The required deceleration time is 10 seconds and is therefore within the specification for the drive.

Now using the required deceleration time of 10 seconds, calculate the required braking torque:

$$M_b = \frac{2 \times \pi \times 1450}{30 \times 10}$$

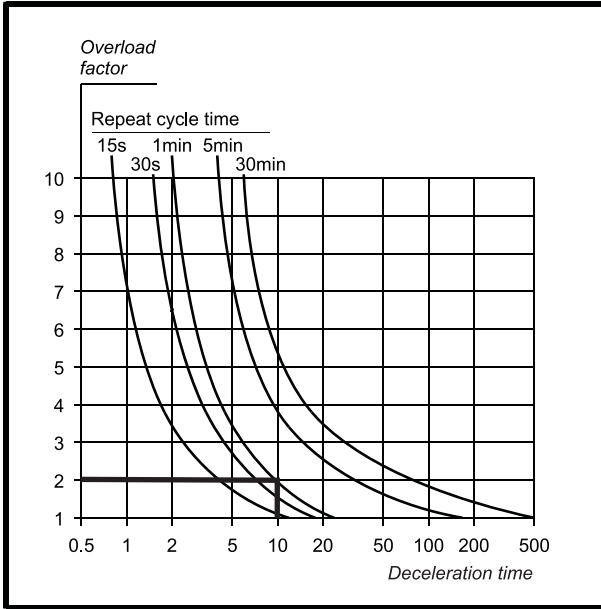
$$M_b = 30.4\text{Nm}$$

Now calculate the braking power:

$$\begin{aligned} P_b &= \frac{M_b \times \pi \times n}{30 \times 10^3} \\ &= \frac{30.4 \times \pi \times 1450}{30 \times 10^3} \\ &= 4.6\text{kW} \end{aligned}$$

Since braking occurs intermittently, the resistor can be rated for intermittent rather than continuous power dissipation so that the overload factor of the resistor can be used. This factor can be obtained from the cooling curves for resistor type that is being used. See the following example:

**Figure 5-45 Examples cooling curves for power resistors (in practice, refer to the cooling curves for the resistor to be used)**



The cooling curve indicates that for a braking time of 10 seconds and a repeat cycle time of 60 seconds, the overall factor (F) is 2.0. Calculate the required power rating of the resistor:

$$P_R = \frac{P_b}{F} = \frac{4.6 \times 10^3}{2.0} = 2.3 \text{ kW}$$

Now calculate the value of the braking resistor:

$$R_{\max} = \frac{(VR)^2}{P_b} = \frac{780^2}{4.6 \times 10^3} = 132 \Omega$$

For this example use 120Ω which is the nearest value in the E12 range of resistors.

In practice, use a resistor having a preferred value close to and lower than the calculated value. This is because the calculated value would cause the braking transistor to be switched on almost continuously during braking. In this case, the drive will not have full control of the DC bus voltage. A lower value of braking resistor will cause the braking transistor to act as a chopper which will then allow the drive to control the DC bus voltage more accurately.

This reduction in value does not increase the power dissipation since the average voltage across the resistor is reduced by the braking transistor operating as a chopper.

### 5.3.1 Sizing an appropriate thermal overload relay

Calculate the maximum permissible continuous current through the braking resistor as follows:

$$I_{R_{\max}} = \sqrt{\frac{P_R}{R}} = \sqrt{\frac{2.3 \times 10^3}{120}} = 4.4 \text{ A}$$

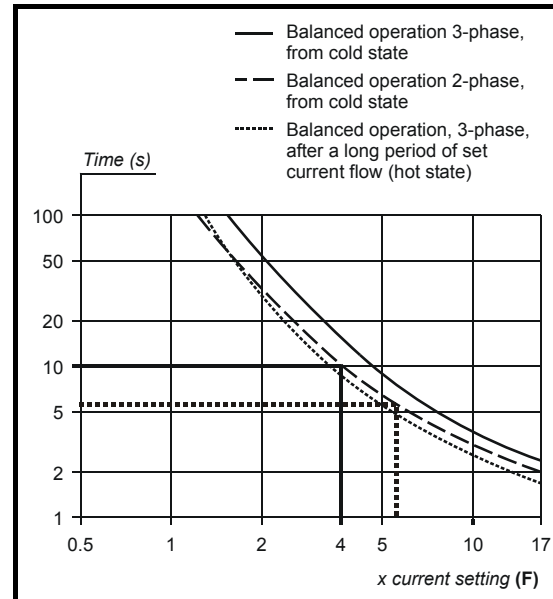
Where:

$P_R$  is the power rating of the resistor to be used.

$R$  is the actual value of the braking resistor (not the calculated).

Use the tripping curves for the chosen manufacturer of thermal overload relay in order to find the overload factor (F) that will cause the relay to trip after 10 seconds.

**Figure 5-46 Example tripping curves for the Telemecanique thermal overload relays type LR-Dx3xx**



Calculate the current setting required for the thermal overload relay as follows:

$$I_{\text{SET}} = \frac{I_{R_{\max}}}{F} = \frac{4.4}{4} = 1.1 \text{ A}$$

Select a model of thermal overload relay that can be set at 1.1A (e.g. Telemecanique LR2-D1306).

Calculate the maximum current that could flow through the resistor (e.g. due to the braking transistor becoming short circuit) as follows:

$$I_{R_{\text{pk}}} = \frac{V_R}{R} = \frac{780}{120} = 6.5 \text{ A}$$

Calculate the overload factor for this condition as follows:

$$F_{S/C} = \frac{I_{R_{\text{pk}}}}{I_{\text{SET}}} = \frac{6.5}{1.1} = 5.9$$

Use the tripping curves to find the time that the thermal overload relay will take to trip (e.g. 5 seconds approximately).

Check that the braking resistor can tolerate the overload current for this duration.

#### NOTE

Braking resistors must be installed equipped with a thermal overload device.

Resistors intended for braking duty should be capable of tolerating thermal shock. 'Pulse rated' resistors are recommended.

The resistance value calculated above does not take into account any tolerance in the resistance value.

The power ratings above are at the limit of satisfactory operation and thus a 10% safety factor should be built in to ensure any tolerances do not add up to cause overvoltage trips. This could be critical where inaccurate values are used for inertia etc. This safety factor should be increased where necessary to incorporate any sort of inaccuracy in values used.

### 5.3.2 Routine maintenance

The drive should be installed in a cool, clean, well ventilated location. Contact of moisture and dust with the drive should be prevented.

Regular checks of the following should be carried out to ensure drive / installation reliability are maximized:

Environment	
Ambient temperature	Ensure the enclosure temperature remains at or below maximum specified
Dust	Ensure the drive remains dust free – check that the heatsink and drive fan are not gathering dust. The lifetime of the fan is reduced in dusty environments.
Moisture	Ensure the drive enclosure shows no signs of condensation
Enclosure	
Enclosure door filters	Ensure filters are not blocked and that air is free to flow
Electrical	
Screw connections	Ensure all screw terminals remain tight
Crimp terminals	Ensure all crimp terminals remains tight – check for any discoloration which could indicate overheating
Cables	Check all cables for signs of damage

### 5.3.3 Heatsink fan

#### Heatsink fan operation

The Commander SK is ventilated by an internal heatsink mounted fan. The fan housing forms a baffle plate, channelling the air through the heatsink chamber. Thus, regardless of the mounting method (surface or through-panel mounting), the fitting of additional baffle plates is not required.

Ensure the minimum clearances around the drive are maintained to allow air to flow freely.

The heatsink fan on Commander SK size D and 2 is a dual speed fan and on size 3 to 6, it is a variable speed fan. The drive controls the speed at which the fan runs based on the temperature of the heatsink and the drive's thermal model system. The Commander SK size 3 to 6 is also installed with a single speed fan to ventilate the capacitor bank.

The heatsink fan on the Commander SK size 2 to 5 is supplied internally by the drive. The heatsink fan on the size 6 requires an external +24Vdc power supply.

#### Heatsink fan supply

The heatsink fan on size 6 requires an external +24Vdc supply. The connections for the heatsink fan supply must be made to the upper terminal connector near to the W phase output on the drive. See Figure 5-47 for the position of the heatsink fan supply connector.

Figure 5-47 Location of size 6 heatsink fan supply connections

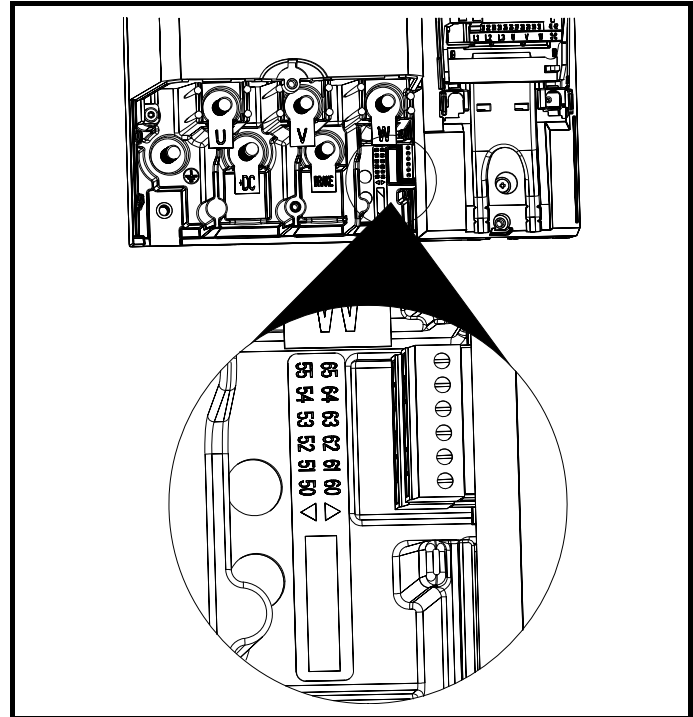
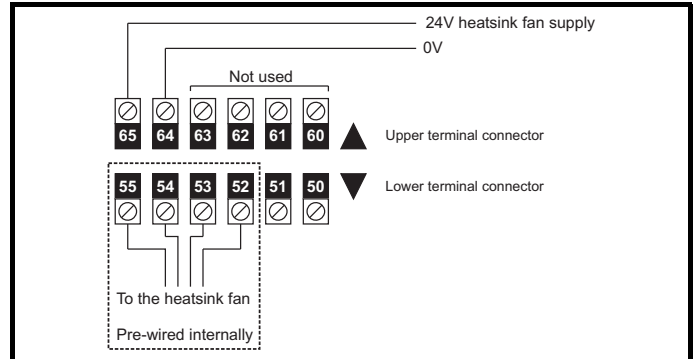


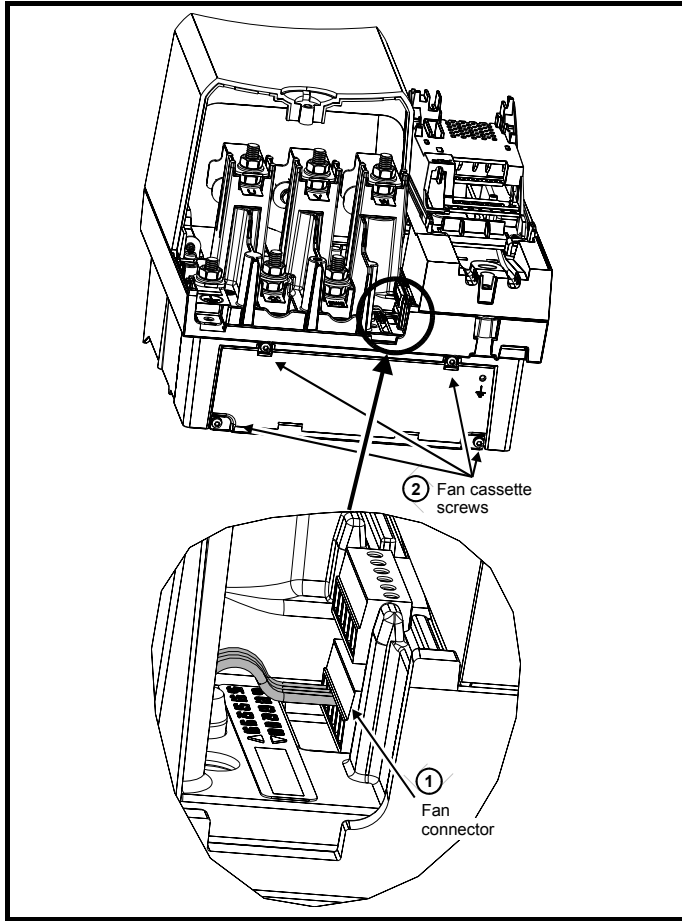
Figure 5-48 Size 6 heatsink fan supply connections



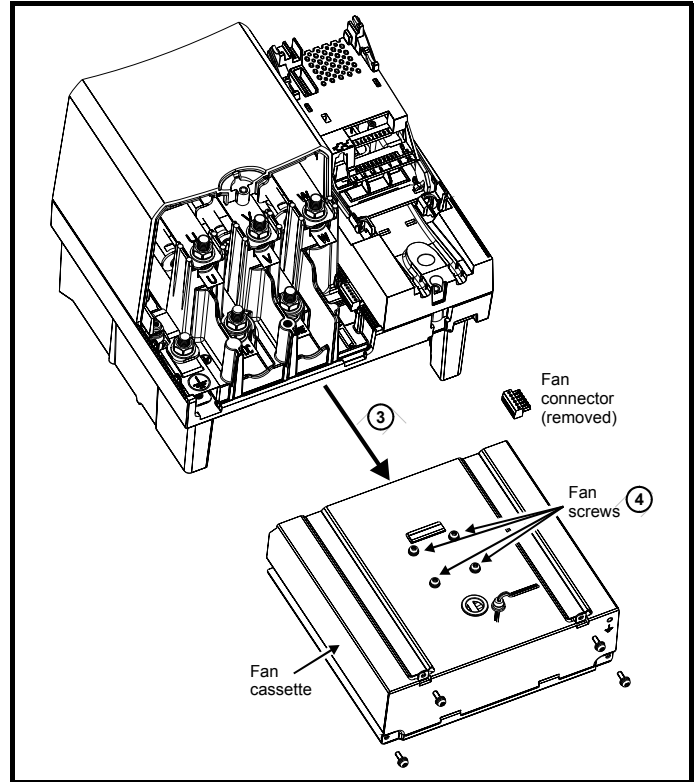
The heatsink fan supply requirements are as follows:

Nominal voltage:	24Vdc
Minimum voltage:	23.5Vdc
Maximum voltage:	27Vdc
Current drawn:	3.3A
Recommended power supply:	24V, 100W, 4.5A
Recommended fuse:	4A fast blow ( $I^2t$ less than $20A^2s$ )

**Figure 5-49 Removal of Commander SK size 6 fan (part 1)**



**Figure 5-50 Removal of Commander SK size 6 fan (part 2)**



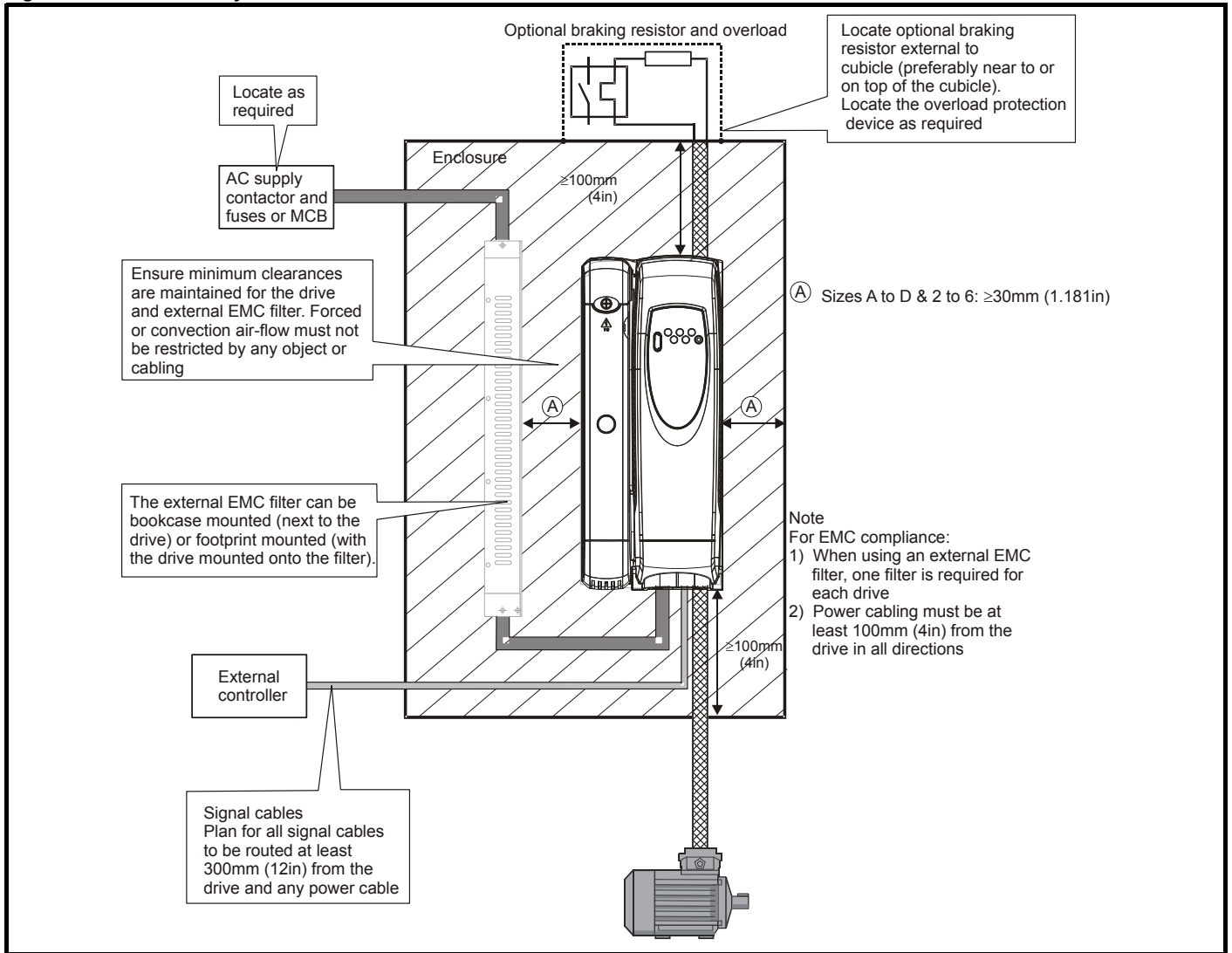
The fan assembly part number for Commander SK size 6 is 9701-0019.

### 5.3.4 Enclosure

#### Enclosure layout (size A to D and 2 to 6)

Please observe the clearances in the diagram below taking into account any appropriate notes for other devices / auxiliary equipment when planning the installation.

Figure 5-51 Enclosure layout



#### Enclosure sizing

- Add the dissipation figures from section 2.5.2 *Drive losses* on page 32 for each drive that is to be installed in the enclosure.
- If an external EMC filter is to be used with each drive, add the dissipation figures from Table 6-9 on page 88 for each external EMC filter that is to be installed in the enclosure.
- If the braking resistor is to be mounted inside the enclosure, add the average power figures for each braking resistor that is to be installed in the enclosure.
- Calculate the total heat dissipation (in Watts) of any other equipment to be installed in the enclosure.
- Add the heat dissipation figures obtained above. This gives a figure in Watts for the total heat that will be dissipated inside the enclosure.

#### Calculating the size of a sealed enclosure

The enclosure transfers internally generated heat into the surrounding air by natural convection (or external forced air flow); the greater the surface area of the enclosure walls, the better is the dissipation capability. Only the surfaces of the enclosure that are unobstructed (not in contact with a wall or floor) can dissipate heat.

Calculate the minimum required unobstructed surface area  $A_e$  for the enclosure from:

$$A_e = \frac{P}{k(T_{int} - T_{ext})}$$

Where:

- $A_e$  Unobstructed surface area in  $\text{m}^2$  ( $1 \text{ m}^2 = 10.9 \text{ ft}^2$ )
- $T_{ext}$  Maximum expected temperature in  $^{\circ}\text{C}$  *outside* the enclosure
- $T_{int}$  Maximum permissible temperature in  $^{\circ}\text{C}$  *inside* the enclosure
- $P$  Power in Watts dissipated by *all* heat sources in the enclosure
- $k$  Heat transmission coefficient of the enclosure material in  $\text{W}/\text{m}^2/^{\circ}\text{C}$

#### Example

To calculate the size of an enclosure for the following:

- Two SK2203 models operating at the Normal Duty rating
- Each drive operate at 6kHz PWM switching frequency
- Schaffner 32A (4200-6210) external EMC filter for each drive
- Braking resistors are to be mounted outside the enclosure
- Maximum ambient temperature inside the enclosure:  $40^{\circ}\text{C}$
- Maximum ambient temperature outside the enclosure:  $30^{\circ}\text{C}$



Losses in each drive: 302W (see section 2.5.2 *Drive losses* on page 32).

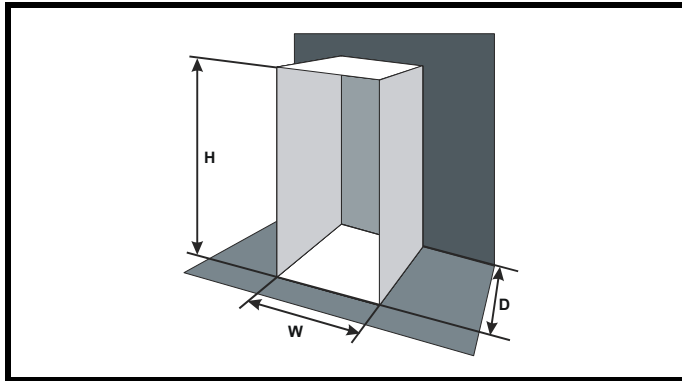
Losses of each external EMC filter: 11W (max) (see section 6.5 *Commander SK size 2 to 6* on page 87).

Total losses:  $2 \times (302 + 11) = 626\text{W}$

The enclosure is to be made from painted 2 mm (0.079 in) sheet steel having a heat transmission coefficient of  $5.5 \text{ W/m}^2/^\circ\text{C}$ . Only the top, front, and two sides of the enclosure are free to dissipate heat.

The value of  $5.5 \text{ W/m}^2/^\circ\text{C}$  can generally be used with a sheet steel enclosure (exact values can be obtained by the supplier of the material). If in any doubt, allow for a greater margin in the temperature rise.

**Figure 5-52 Enclosure having front, sides and top panels free to dissipate heat**



Insert the following values:

$T_{\text{int}}$  40°C  
 $T_{\text{ext}}$  30°C  
 $k$  5.5  
 $P$  626 W

The minimum required heat conducting area is then:

$$A_e = \frac{626}{5.5(40 - 30)}$$

$$= 11.38 \text{ m}^2 \text{ (124 ft}^2\text{)} \quad (1 \text{ m}^2 = 10.9 \text{ ft}^2)$$

Estimate two of the enclosure dimensions - the height (H) and depth (D), for instance. Calculate the width (W) from:

$$W = \frac{A_e - 2HD}{H + D}$$

Inserting  $H = 2\text{m}$  and  $D = 0.6\text{m}$ , obtain the minimum width:

$$W = \frac{11.38 - (2 \times 2 \times 0.6)}{2 + 0.6}$$

$$= 3.454 \text{ m (136 in)}$$

If the enclosure is too large for the space available, it can be made smaller only by attending to one or all of the following:

- Using a lower PWM switching frequency to reduce the dissipation in the drives
- Reducing the ambient temperature outside the enclosure, and/or applying forced-air cooling to the outside of the enclosure
- Reducing the number of drives in the enclosure
- Removing other heat-generating equipment

### Calculating the air-flow in a ventilated enclosure

The dimensions of the enclosure are required only for accommodating the equipment. The equipment is cooled by the forced air flow.

Calculate the minimum required volume of ventilating air from:

$$V = \frac{3kP}{T_{\text{int}} - T_{\text{ext}}}$$

Where:

$V$  Air-flow in  $\text{m}^3$  per hour ( $1 \text{ m}^3/\text{hr} = 0.59 \text{ ft}^3/\text{min}$ )  
 $T_{\text{ext}}$  Maximum expected temperature in  $^\circ\text{C}$  *outside* the enclosure  
 $T_{\text{int}}$  Maximum permissible temperature in  $^\circ\text{C}$  *inside* the enclosure  
 $P$  Power in Watts dissipated by *all* heat sources in the enclosure  
 $k$  Ratio of  $\frac{P_o}{P_i}$

Where:

$P_o$  is the air pressure at sea level  
 $P_i$  is the air pressure at the installation

Typically use a factor of 1.2 to 1.3, to allow also for pressure-drops in dirty air-filters.

### Example

To calculate the size of an enclosure for the following:

- Three SK3201 models operating at the Normal Duty rating
- Each drive to operate at 6kHz PWM switching frequency
- Schaffner 75A (4200-6307) external EMC filter for each drive
- Braking resistors are to be mounted outside the enclosure
- Maximum ambient temperature inside the enclosure: 40°C
- Maximum ambient temperature outside the enclosure: 30°C

Losses in each drive: 380W

Losses of each external EMC filter: 29W (max)

Total losses:  $3 \times (380 + 29) = 1227\text{W}$

Insert the following values:

$T_{\text{int}}$  40°C  
 $T_{\text{ext}}$  30°C  
 $k$  1.3  
 $P$  1227 W

Then:

$$V = \frac{3 \times 1.3 \times 1227}{40 - 30}$$

$$= 478.5 \text{ m}^3/\text{hr} \text{ (282.3 ft}^3/\text{min)} \quad (1 \text{ m}^3/\text{hr} = 0.59 \text{ ft}^3/\text{min})$$



### 5.3.5 Enclosure design and drive ambient temperature

Drive derating is required for operation in high ambient temperatures. Totally enclosing or through panel mounting the drive in either a sealed cabinet (no airflow) or in a well ventilated cabinet makes a significant difference on drive cooling.

The chosen method affects the ambient temperature value ( $T_{rate}$ ) which should be used for any necessary derating to ensure sufficient cooling for the whole of the drive.

The ambient temperature for the four different combinations is defined below:

- Totally enclosed with no air flow (<2 m/s) over the drive  
 $T_{rate} = T_{int} + 5^{\circ}\text{C}$
- Totally enclosed with air flow (>2 m/s) over the drive  
 $T_{rate} = T_{int}$
- Through panel mounted with no airflow (<2 m/s) over the drive  
 $T_{rate} = \text{the greater of } T_{ext} + 5^{\circ}\text{C}, \text{ or } T_{int}$
- Through panel mounted with air flow (>2 m/s) over the drive  
 $T_{rate} = \text{the greater of } T_{ext} \text{ or } T_{int}$

Where:

$T_{ext}$  = Temperature outside the cabinet

$T_{int}$  = Temperature inside the cabinet

$T_{rate}$  = Temperature used to select current rating from tables in Chapter 2 *Derating curves and losses*.

### 5.3.6 Fire enclosure

When the drive conforms to UL type 1, the UL508C listed type 1 drives meet the US fire enclosure requirements.

For installation in the USA, a NEMA 12 enclosure is suitable.

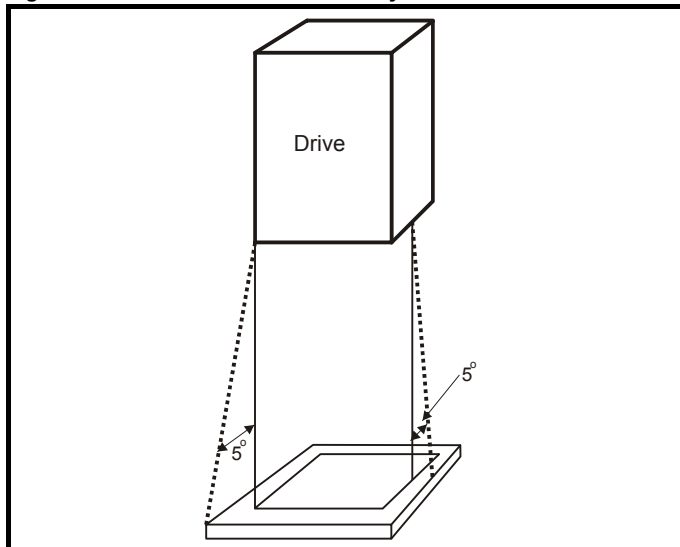
For installation outside the USA, the following (based on IEC 62109-1, standard for PV inverters) is recommended.

Enclosure can be metal and/or polymeric, polymer must meet requirements which can be summarized for larger enclosures as using materials meeting at least UL 94 class 5VB at the point of minimum thickness.

Air filter assemblies to be at least class V-2.

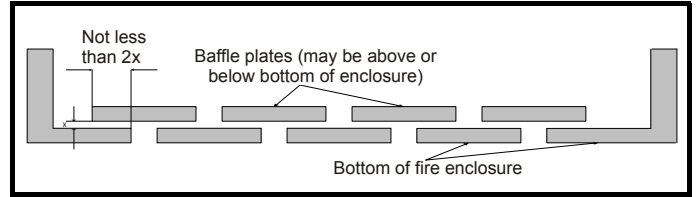
The location and size of the bottom shall cover the area shown in Figure 5-53. Any part of the side which is within the area traced out by the 5° angle is also considered to be part of the bottom of the fire enclosure.

**Figure 5-53 Fire enclosure bottom layout**



The bottom, including the part of the side considered to be part of the bottom, must be designed to prevent escape of burning material - either by having no openings or by having a baffle construction. This means that openings for cables etc. must be sealed with materials meeting the 5VB requirement, or else have a baffle above. See Figure 5-54 for acceptable baffle construction. This does not apply for mounting in an enclosed electrical operating area (restricted access) with concrete floor.

**Figure 5-54 Fire enclosure baffle construction**



## 6 EMC

### 6.1 Ground leakage

The ground leakage current depends upon the internal EMC filter being installed. The drive is supplied with the filter installed. Instructions for removal of the internal EMC filter are given in section 6.2 *Internal EMC filter* on page 79.

#### With internal EMC filter installed

##### Size A

###### 1 phase 110V product

4mA AC at 110V, 50Hz (proportional to supply voltage and frequency)

###### 1 phase 200V product

10mA AC at 230V, 50Hz (proportional to supply voltage and frequency)

##### Size B

###### 1 phase 110V product

10mA AC at 110V, 50Hz (proportional to supply voltage and frequency)

##### Size B and C

###### 1 phase 200V product

20mA AC at 230V, 50Hz (proportional to supply voltage and frequency)

###### 3-phase 200V product

7mA AC at 230V, 50Hz (proportional to supply voltage and frequency)

###### 3-phase 400V product

8.2mA AC at 415V, 50Hz (proportional to supply voltage and frequency)

##### Size D

###### 1 phase 200V product

20.5mA AC at 230V, 50Hz (proportional to supply voltage and frequency)

###### 3-phase 200V product

8mA AC at 230V, 50Hz (proportional to supply voltage and frequency)

###### 3-phase 400V product

10.5mA AC at 415V, 50Hz (proportional to supply voltage and frequency)

##### Size 2 and 3

28mA AC at 400V, 50Hz (proportional to supply voltage and frequency)

30 $\mu$ A DC with a 600V DC bus (10M $\Omega$ )

##### Size 4 to 6

56mA AC at 400V, 50Hz (proportional to supply voltage and frequency)

18 $\mu$ A DC with a 600V DC bus (33M $\Omega$ )

#### NOTE

The above leakage currents are just the leakage currents of the drive with the internal EMC filter connected and do not take into account any leakage currents of the motor or motor cable.

#### With internal EMC filter removed

<1mA

#### NOTE

In both cases, there is an internal voltage surge suppression device connected to ground. Under normal circumstances, this carries negligible current.



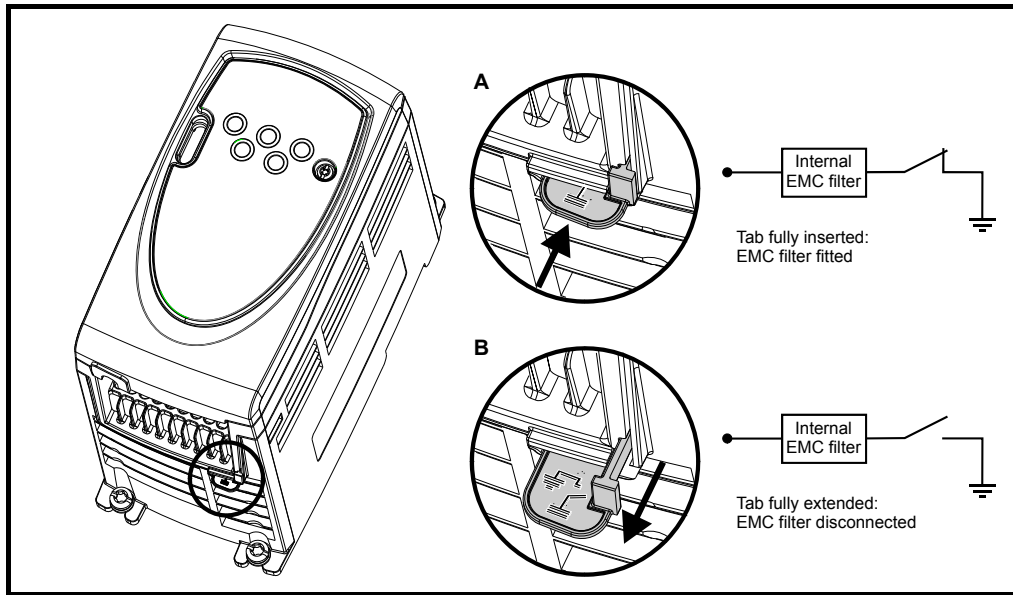
WARNING

When the internal EMC filter is installed, the leakage current is high. In this case, a permanent fixed ground connection must be provided using two independent conductors each with a cross-section equal to or exceeding that of the supply conductors. The drive is provided with two ground terminals to facilitate this. The purpose is to prevent a safety hazard occurring if the connection is lost.

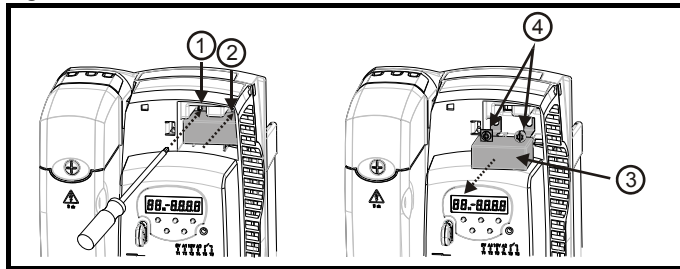
## 6.2 Internal EMC filter

It is recommended that the internal EMC filter be kept in place unless there is a specific reason for removing it.

**Figure 6-1 Removal and re-fitting of internal EMC filter, Size A to D**



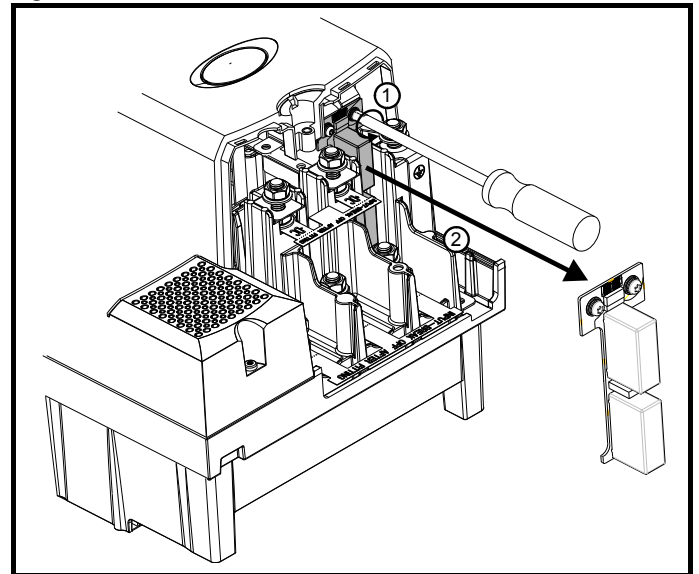
**Figure 6-2 Removal of the internal EMC filter, size 2 and 3**



Loosen/remove screws as shown (1) and (2).

Remove filter (3) and ensure the screws are replaced and re-tightened (4).

**Figure 6-3 Removal of the internal EMC filter, size 4, 5 and 6**



Loosen screws (1). Remove EMC filter in the direction shown (2).

The internal EMC filter reduces radio-frequency emissions into the mains supply. Where the motor cable length is short, it permits the requirements of EN 61800-3:2004 to be met for the second environment. For longer motor cables, the filter continues to provide a useful reduction in emission level, and when used with any length of shielded motor cable up to the limit for the drive, it is unlikely that nearby industrial equipment will be disturbed. It is recommended that the filter be used in all applications unless the instructions given above require it to be removed or the ground leakage current of 28mA is unacceptable.

### 6.3 Electromagnetic compatibility (EMC)

This is a summary of the EMC performance of the drive.

**Table 6-1 Immunity compliance**

Standard	Type of immunity	Test specification	Application	Level
IEC61000-4-2 EN61000-4-2	Electrostatic discharge	6kV contact discharge 8kV air discharge	Module enclosure	Level 3 (industrial)
IEC61000-4-3 EN61000-4-3	Radio frequency radiated field	10V/m prior to modulation 80 - 1000MHz 80% AM (1kHz) modulation	Module enclosure	Level 3 (industrial)
IEC61000-4-4 EN61000-4-4	Fast transient burst	5/50ns 2kV transient at 5kHz repetition frequency via coupling clamp	Control lines	Level 4 (industrial harsh)
		5/50ns 2kV transient at 5kHz repetition frequency by direct injection	Power lines	Level 3 (industrial)
IEC61000-4-5 EN61000-4-5	Surges	Common mode 4kV 1.2/50µs waveshape	AC supply lines: line to ground	Level 4
		Differential mode 2kV 1.2/50µs waveshape	AC supply lines: line to line	Level 3
		Lines to ground	Signal ports to ground <sup>1</sup>	Level 2
IEC61000-4-6 EN61000-4-6	Conducted radio frequency	10V prior to modulation 0.15 - 80MHz 80% AM (1kHz) modulation	Control and power lines	Level 3 (industrial)
IEC61000-4-11 EN61000-4-11	Voltage dips and interruptions	-30% 10ms +60% 100ms -60% 1s <-95% 5s	AC power ports	
EN50082-1 IEC61000-6-1 EN 61000-6-1:2007	Generic immunity standard for the residential, commercial and light - industrial environment			Complies
EN50082-2 IEC61000-6-2 EN 61000-6-2:2005	Generic immunity standard for the industrial environment			Complies
EN 61800-3:2004 IEC61800-3	Product standard for adjustable speed power drive systems (immunity requirements)		Meets immunity requirements for first and second environments	

<sup>1</sup> See section *Surge immunity of control circuits - long cables and connections outside a building* on page 97 for control ports for possible requirements regarding grounding and external surge protection

#### Emission

The drive contains an in-built filter for basic emission control. An additional optional external filter provides further reduction of emission. The requirements of the standards are met, depending on the motor cable length and switching frequency.

## 6.4 Commander SK size A to D

EMC filters are available as optional extra parts where required.

**Table 6-2 EMC filter data**

Used with	Number of phases	Filter part number		Filter type		Mounting		Max motor cable length (m)
		CT	Schaffner	Standard	Low leakage	Footprint	Side	
SKA1100025, SKA1100037, SKA1200025 and SKA1200037	1	4200-6122	FS6512-12-07	Y		Y	Y	50
		4200-6123	FS6512-12-07-LL		Y	Y	Y	30
SKA1200055 and SKA1200075	1	4200-6122	FS6512-12-07	Y		Y	Y	75
		4200-6123	FS6512-12-07-LL		Y	Y	Y	30
SKB1100075 and SKB1100110	1	4200-6216	FS6513-27-07	Y		Y	Y	100
SKBD200110 to SKBD200150	1	4200-6212	FS6513-20-07	Y		Y	Y	100
		4200-6214	FS6513-20-07-LL		Y	Y	Y	75
SKBD200110 to SKBD200150	3	4200-6213	FS6513-10-07	Y		Y	Y	100
		4200-6215	FS6513-10-07-LL		Y	Y	Y	15
SKB3400037 to SKB3400150	3	4200-6213	FS6513-10-07	Y		Y	Y	100
		4200-6215	FS6513-10-07-LL		Y	Y	Y	15
SKCD200220	1	4200-6310	FS6514-24-07	Y		Y	Y	100
		4200-6312	FS6514-24-07-LL		Y	Y	Y	10
SKCD200220	3	4200-6311	FS6514-14-07	Y		Y	Y	100
		4200-6217	FS6514-14-07-LL		Y	Y	Y	50
SKC3400220 to SKC3400400	3	4200-6311	FS6514-14-07	Y		Y	Y	100
		4200-6217	FS6514-14-07-LL		Y	Y	Y	20
SKDD200300	1	4200-6409	FS6515-24-07	Y		Y	Y	100
		4200-6410	FS6515-24-07-LL		Y	Y	Y	10
SKDD200300	3	4200-6411	FS6515-16-07	Y		Y	Y	100
		4200-6412	FS6515-16-07-LL		Y	Y	Y	10
SKD3200400, SKD3400550 and SKD3400750	3	4200-6411	FS6515-16-07	Y		Y	Y	100
		4200-6412	FS6515-16-07-LL		Y	Y	Y	10

**Table 6-3 EMC filter ratings**

Used with	Number of phases	Filter part number		Power losses at rated current W	IP rating	Weight		Operational leakage current mA	Worst case leakage current mA	Filter terminal tightening torque		Filter current rating A	
		CT	Schaffner			kg	lb			Nm	lb ft		
SKA1100025, SKA1100037, SKA1200025 and SKA1200037	1	4200-6122	FS6512-12-07	4.1	20	0.42	0.9	25.7	49.5	0.8	0.6	12	
		4200-6123	FS6512-12-07-LL	6.7		0.44	1.0	2.5	5	0.8	0.6	12	
SKB1100075 and SKB1100110	1	4200-6216	FS6513-27-07	7.2		0.68	1.5	24.9	48.2	0.8	0.6	27	
SKBD200110 to SKBD200150	1	4200-6212	FS6513-20-07	11.2		0.57	1.3	25.7	50	0.8	0.6	20	
		4200-6214	FS6513-20-07-LL	12.8		0.64	1.4	3.6	7	0.8	0.6	20	
SKBD200110 to SKBD200150	3	4200-6213	FS6513-10-07	7.5		0.63	1.4	40	137.2	0.8	0.6	10	
		4200-6215	FS6513-10-07-LL	7.5		0.63	1.4	3	18.3	0.8	0.6	10	
SKB3400037 to SKB3400150	3	4200-6213	FS6513-10-07	7.5		0.63	1.4	40	137.2	0.8	0.6	10	
		4200-6215	FS6513-10-07-LL	7.5		0.63	1.4	3	18.3	0.8	0.6	10	
SKCD200220	1	4200-6310	FS6514-24-07	16.2		0.84	1.9	25.7	50	0.8	0.6	24	
		4200-6312	FS6514-24-07-LL	18.5		0.91	2.0	3.6	7	0.8	0.6	24	
SKCD200220	3	4200-6311	FS6514-14-07	11.8		0.75	1.7	40	137.2	0.8	0.6	14	
		4200-6217	FS6514-14-07-LL	11.8		0.74	1.6	3	18.3	0.8	0.6	14	
SKC3400220 to SKC3400400	3	4200-6311	FS6514-14-07	11.8		0.75	1.7	40	137.2	0.8	0.6	14	
		4200-6217	FS6514-14-07-LL	11.8		0.74	1.6	3	18.3	0.8	0.6	14	
SKDD200300	1	4200-6409	FS6515-24-07	13.8		1.65	3.6	14.3	28.4	1.2	0.9	24	
		4200-6410	FS6515-24-07-LL	11.52				2.3	4.62				
SKDD200300	3	4200-6411	FS6515-16-07	17.28				40	137.2				
		4200-6412	FS6515-16-07-LL	17.28				3	18.3				
SKD3200400, SKD3400550 and SKD3400750	3	4200-6411	FS6515-16-07	11.52				1.55	3.4				40
		4200-6412	FS6515-16-07-LL	17.28	3								18.3

### 6.4.1 Conformity

Table 6-4 Conformity size A to B

Used with	Number of phases	Motor cable length (m)	Filter and switching frequency											
			Internal				Standard				Low leakage			
			3kHz	6kHz	12kHz	18kHz	3kHz	6kHz	12kHz	18kHz	3kHz	6kHz	12kHz	18kHz
SKA1100025 and SKA1100037	1	20	E2R				R							
		50	E2R											
SKA1200025 and SKA1200037	1	5	E2U		E2R		R				R			
		10	E2U	E2R			R				R			
		20	E2R				R							
		30	E2R											
		50	E2R											
SKA1200055 and SKA1200075	1	5	E2U		E2R		R				R			
		10	E2U	E2R			R				R			
		20	E2R				R							
		30	E2R											
		50	E2R											
		75	E2R							E2U				
SKB1100075 and SKB1100110	1	4	E2U		E2R		R							
		10	E2R				R							
		20	E2R				R							
		50	E2R											
		75	E2R											
		100	E2R											
SKBD200110 to SKBD200150	1	4	E2U		E2R		R				R			
		10	E2R				R				R			
		40	E2R											
		50	E2R											
		75	E2R											
		100	E2R											
SKBD200110 to SKBD200150	3	2	E2U		E2R		R				R			
		4	E2U	E2R			R				R			
		5	E2R				R				R			
		9	E2R				R				R			
		15	E2R				R							
		50	E2R				R							
		75	E2R											
		100	E2R											
SKB3400037 to SKB3400150	3	2	E2U		R				R					
		5	E2U		E2R		R				R			
		9	E2U		E2R		R				R			
		15	E2R				R							
		50	E2R				R							
		75	E2R											
		100	E2R											

**Table 6-5 Conformity size C**

Used with	Number of phases	Motor cable length (m)	Filter and switching frequency											
			Internal				Standard				Low leakage			
			3kHz	6kHz	12kHz	18kHz	3kHz	6kHz	12kHz	18kHz	3kHz	6kHz	12kHz	18kHz
SKCD200220	1	7	E2U		E2R		R				R	I		
		9	E2U	E2R			R				R	I		
		10	E2R				R				R	I		
		15	E2R				R							
		20	E2R				R			I				
		100	E2R				I							
SKCD200220	3	4	E2U		E2R		R						I	
		5	E2U		E2R		R						I	
		10	E2R				R						I	
		20	E2R				R						I	
		50	E2R				R			I	I			
		75	E2R				I							
		100	E2R				I	I						
SKC3400220 to SKC3400400	3	4	E2U		E2R		R						I	
		5	E2U	E2R			R						I	
		10	E2R				R						I	
		20	E2R				R						I	
		50	E2R				I							
		75	E2R				I							
		100	E2R				I							

**Table 6-6 Conformity size D**

Used with	Number of phases	Motor cable length (m)	Filter and switching frequency								
			Internal with external ferrite ring*			Standard			Low leakage		
			3kHz	6kHz	12kHz	3kHz	6kHz	12kHz	3kHz	6kHz	12kHz
SKDD200300	1	10				R			R		
		20				R					
		50				I					
		100				I					
SKDD200300	3	10				R			R		
		20				R					
		50				I					
		100				I					
SKD3200400, SKD3400550 and SKD3400750	3	8	E2U	E2R		R			R		
		10	E2R				R		R		
		20	E2R				R	I	I		
		50	E2R				I	I			
		100	E2R				I	I	-		


\*Ferrite ring is supplied with the drive.



### Key to Conformity

The requirements are listed in descending order of severity, so that if a particular requirement is met then all requirements listed after it are also met.

	Standard	Description	Frequency range	Limits	Application
R	EN 61000-6-3:2007	Generic emission standard for the residential commercial and light - industrial environment	0.15 - 0.5MHz	66-56dB $\mu$ V quasi peak 56-46dB $\mu$ V average	AC supply lines
			0.5 - 5MHz	56dB $\mu$ V quasi peak 46dB $\mu$ V average	
			5 - 30MHz	60dB $\mu$ V quasi peak 50dB $\mu$ V average	
	EN 61800-3:2004 IEC 61800-3	Product standard for adjustable speed power drive systems	Requirements for the first environment <sup>1</sup> , with unrestricted distribution		
I	EN 61000-6-4:2007	Generic emission standard for the industrial environment	0.15 - 0.5MHz	79dB $\mu$ V quasi peak 66dB $\mu$ V average	AC supply lines
			0.5 - 30MHz	73dB $\mu$ V quasi peak 60dB $\mu$ V average	
	EN 61800-3:2004 IEC 61800-3	Product standard for adjustable speed power drive systems	Requirements for the first environment <sup>1</sup> with restricted distribution <sup>2</sup>		
E2U	EN 61800-3:2004 IEC 61800-3	Product standard for adjustable speed power drive systems	Requirements for the second environment with unrestricted distribution		
E2R	EN 61800-3:2004 IEC 61800-3	Product standard for adjustable speed power drive systems	Requirements for the second environment with restricted distribution <sup>2</sup>		
Operation in this condition is not recommended					
1	The first environment is one where the low voltage supply network also supplies residential premises				
2	When distribution is restricted, drives are available only to installers with EMC competence				



This caution applies where the drive is used in the first environment according to EN 61800-3:2004. This is a product of the restricted distribution class according to IEC 61800-3. In a residential environment this product may cause radio interference in which case the user may be required to take adequate measures.

#### NOTE

Where the drive is incorporated into a system with rated input current exceeding 100A, the higher emission limits of EN 61800-3:2004 for the second environment are applicable, and no filter is then required.

#### NOTE

Operation without an external filter is a practical cost-effective possibility in an industrial installation where existing levels of electrical noise are likely to be high, and any electronic equipment in operation has been designed for such an environment. This is in accordance with EN 61800-3:2004 in the second environment, with restricted distribution. There is some risk of disturbance to other equipment, and in this case the user and supplier of the drive system must jointly take responsibility for correcting any problem which occurs.

For the size D only to meet the requirements in the second environment when using the internal EMC filter, the motor cables (U, V and W) need to be fed twice through a ferrite ring (supplied with the drive).

#### IEC 61800-3:2004 and EN 61800-3:2004

The 2004 revision of the standard uses different terminology to align the requirements of the standard better with the EC EMC Directive.

Power drive systems are categorized C1 to C4:

Category	Definition	Corresponding code used above
C1	Intended for use in the first or second environments	R
C2	Not a plug-in or movable device, and intended for use in the first environment only when installed by a professional, or in the second environment	I
C3	Intended for use in the second environment, not the first environment	E2U
C4	Rated at over 1000V or over 400A, intended for use in complex systems in the second environment	E2R

Note that category 4 is more restrictive than E2R, since the rated current of the PDS must exceed 400A or the supply voltage exceed 1000V, for the complete PDS.

### Related product standards

The conducted emission levels specified in EN 61800-3:2004 and EN 61000-6-4:2007 are equivalent to the levels required by the following product specific standards:

Conducted emission from 150kHz to 30MHz		
Generic standard	Product standard	
EN 61800-3:2004	EN 55011 Class B CISPR 11 Class B	Industrial, scientific and medical equipment
	EN 55014 CISPR 14	Household electrical appliances
	EN 55022 Class B CISPR 22 Class B	Information technology equipment
EN 61000-6-4:2007	EN 55011 Class A Group 1 CISPR 11 Class A Group 1	Industrial, scientific and medical equipment
	EN 55022 Class A CISPR 22 Class A	Information technology equipment

Figure 6-4 EMC filter dimensions

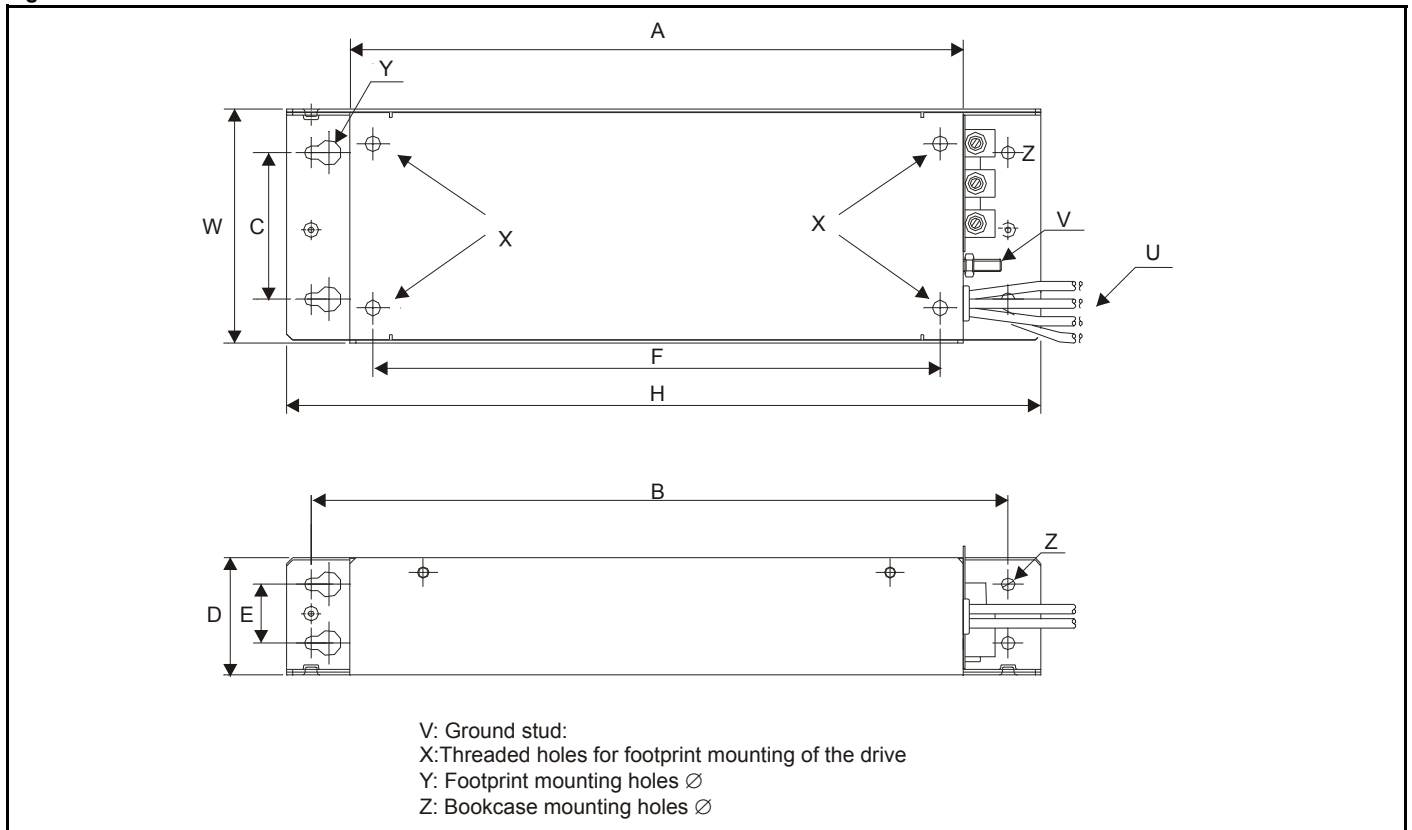


Table 6-7 EMC filter dimensions

CT part no.	Schaffner part no.	A	B	C	D	E	F	H	U	V	W	X	Y	Z
4200-6122	FS6512-12-07	155mm (6.10in)	183.5mm (7.22in)	45mm (1.77in)	40mm (1.57in)	20mm (0.78in)	144mm (5.66in)	203mm (7.99in)	16 AWG	M4	75mm (2.95in)	M4	8.7mm (0.34in)	4.5mm (0.17in)
4200-6123	FS6512-12-07-LL	155mm (6.10in)	183.5mm (7.22in)	45mm (1.77in)	40mm (1.57in)	20mm (0.78in)	144mm (5.66in)	203mm (7.99in)	16 AWG	M4	75mm (2.95in)	M4	8.7mm (0.34in)	4.5mm (0.17in)
4200-6212	FS6513-20-07	209mm (8.22in)	237.7mm (9.35in)	50mm (1.96in)	40mm (1.57in)	20mm (0.78in)	193.5mm (7.61in)	257.2mm (10.12in)	14 AWG	M4	80mm (3.15in)	M4	8.7mm (0.34in)	4.5mm (0.17in)
4200-6214	FS6513-20-07-LL	209mm (8.22in)	237.7mm (9.35in)	50mm (1.96in)	40mm (1.57in)	20mm (0.78in)	193.5mm (7.61in)	257.2mm (10.12in)	14 AWG	M4	80mm (3.15in)	M4	8.7mm (0.34in)	4.5mm (0.17in)
4200-6213	FS6513-10-07	209mm (8.22in)	237.7mm (9.35in)	50mm (1.96in)	40mm (1.57in)	20mm (0.78in)	193.5mm (7.61in)	257.2mm (10.12in)	14 AWG	M4	80mm (3.15in)	M4	8.7mm (0.34in)	4.5mm (0.17in)
4200-6215	FS6513-10-07-LL	209mm (8.22in)	237.7mm (9.35in)	50mm (1.96in)	40mm (1.57in)	20mm (0.78in)	193.5mm (7.61in)	257.2mm (10.12in)	14 AWG	M4	80mm (3.15in)	M4	8.7mm (0.34in)	4.5mm (0.17in)
4200-6216	FS6513-27-07	209mm (8.22in)	237.7mm (9.35in)	50mm (1.96in)	40mm (1.57in)	20mm (0.78in)	193.5mm (7.61in)	257.2mm (10.12in)	12 AWG	M4	80mm (3.15in)	M4	8.7mm (0.34in)	4.5mm (0.17in)

Technical data	Derating curves and losses	Drive voltage levels	DC bus design	Mechanical installation	EMC	AC line reactors	Motor cable lengths	General data	I/O specification	Supply types	Options			
CT part no.	Schaffner part no.	A	B	C	D	E	F	H	U	V	W	X	Y	Z
4200-6310	FS6514-24-07	260mm (10.23in)	288.5mm (11.35in)	65mm (2.55in)	45mm (1.77in)	20mm (0.78in)	244mm (9.60in)	308mm (12.12in)	12 AWG	M4	94mm (3.70in)	M4	8.7mm (0.34in)	4.5mm (0.17in)
4200-6312	FS6514-24-07-LL	260mm (10.23in)	288.5mm (11.35in)	65mm (2.55in)	45mm (1.77in)	20mm (0.78in)	244mm (9.60in)	308mm (12.12in)	12 AWG	M4	94mm (3.70in)	M4	8.7mm (0.34in)	4.5mm (0.17in)
4200-6311	FS6514-14-07	260mm (10.23in)	288.5mm (11.35in)	65mm (2.55in)	45mm (1.77in)	20mm (0.78in)	244mm (9.60in)	308mm (12.12in)	16 AWG	M4	94mm (3.70in)	M4	8.7mm (0.34in)	4.5mm (0.17in)
4200-6217	FS6514-14-07-LL	260mm (10.23in)	288.5mm (11.35in)	65mm (2.55in)	45mm (1.77in)	20mm (0.78in)	244mm (9.60in)	308mm (12.12in)	16 AWG	M4	94mm (3.70in)	M4	8.7mm (0.34in)	4.5mm (0.17in)
4200-6409	FS6515-24-07	338mm (13.31in)	396.5mm (15.61in)	86mm (3.39in)	51.5mm (2.03in)	23mm (0.91in)	315mm (12.40in)	416mm (16.38in)	12 AWG	M6	114.5mm (4.51in)	12mm (0.47in)	6.5mm (0.26in)	
4200-6410	FS6515-24-07-LL								14 AWG					
4200-6411	FS6515-16-07													
4200-6412	FS6515-16-07-LL													

## 6.5 Commander SK size 2 to 6

Table 6-8 External EMC filter data

Drive	Filter part number		Mounting		Max motor cable length to meet EMC requirements (m)
	Schaffner	Epcos	Footprint	Side	
SK2201 to SK2203	4200-6210		Y	Y	100
		4200-6211	Y	Y	
SK3201 to SK3202	4200-6307		Y	Y	
		4200-6306	Y	Y	
SK4201 to SK4203	4200-6406		Y	Y	
		4200-6405	Y	N	
SK2401 to SK2404	4200-6210		Y	Y	
		4200-6211	Y	Y	
SK3401 to SK3403	4200-6305		Y	Y	
		4200-6306	Y	Y	
SK4401 to SK4403	4200-6406		Y	N	
		4200-6405	Y	N	
SK5401 to SK5402	4200-6503		Y	N	
		4200-6501	Y	N	
SK6401 to SK6402	4200-6603		Y	N	
		4200-6601	Y	N	
SK3501 to SK3507	4200-6309		Y	Y	
		4200-6308	Y	Y	
SK4601 to SK4606	4200-6408		Y	N	
		4200-6407	Y	N	
SK5601 to SK5602	4200-6504		Y	N	
		4200-6502	Y	N	
SK6601 to SK6602	4200-6604		Y	N	
		4200-6602	Y	N	

**Table 6-9 External EMC filter ratings**

CT part number	Manufacturer	Maximum continuous current		Voltage rating V	IP rating	Power dissipation at rated current W	Ground leakage		Discharge resistors	
		@ 40°C (104°F) A	@ 50°C (122°F) A				Balanced supply phase-to-phase and phase-to-ground mA	Worst case mA		
4200-6210	Schaffner	32	28.2	400	20	11	38.0	206	See Note 1	
4200-6305		62	56.6	400		23	66.0	357		
4200-6307		75	68.5	240		29	24.0	170		
4200-6309		30	30	575		15	102.0	557	See Note 3	
4200-6406		101	92.2	400		25	73.0	406	See Note 1	
4200-6408		58	52.8	690		31	66.0	344	See Note 1	
4200-6503		164	150	480		30	39.1	216	See Note 4	
4200-6504		95	86.7	690		30	66.0	344	See Note 1	
4200-6603		260	237	480		00	14.2	41.0		219
4200-6604		160	146	690		00	5.4	88.5	296	
4200-6211	Epcos	32	29.1	400	20	17.8	<30.0	186.5	See Note 2	
4200-6306		75	68.3			19.4		238		
4200-6308		30	22.5			17.6		230		
4200-6405		101	75			30	180			
4200-6407		58	44	690		15	<40.0	<340	See Note 5	
4200-6501		165	125	480		27	<20.0	<120	See Note 2	
4200-6502		95	71	690		19	<55.0	<450	See Note 5	
4200-6601		260	195	480		00	13	<45.0		<375
4200-6602		160	120	690		00	5	<60.0		<520

**NOTE**

1. 1MΩ in a star connection between phases, with the star point connected by a 680kΩ resistor to ground (i.e. line to line 2MΩ, line to ground 1.68MΩ)
2. 1MΩ in a star connection between phases, with the star point connected by a 1.5MΩ resistor to ground (i.e. line to line 2MΩ, line to ground 2.5MΩ)
3. 2MΩ between phases with each phase connected by a 660kΩ resistance to ground.
4. 1.5MΩ in a star connection between phases, with the star point connected by a 680kΩ resistor to ground (i.e. line to line 3MΩ, line to ground 2.18MΩ)
5. 1.8MΩ in a star connection between phases, with the star point connected by a 1.5MΩ resistor to ground (i.e. line to line 3.6MΩ, line to ground 3.3MΩ)

### 6.5.1 Conformity for sizes 2 to 6

Table 6-10 Conformity size 2 to 4

Drive	Motor cable length (m)	Filter and switching frequency									
		Internal			Internal and ferrite*			External			
		3kHz	6kHz	12kHz	3kHz	6kHz	12kHz	3kHz	6kHz	12kHz	
SK2201 to SK2203	Any	E2R									
	0 to 4				E2U		E2R				
	4 to 10				E2U	E2R					
	> 10				E2R						
	0 to 25							R		I	
	25 to 75							I			
75 to 100							I				
SK2401 to SK2404	Any	E2R									
	0 to 4				E2U		E2R				
	4 to 10				E2U	E2R					
	> 10				E2R						
	0 to 25							R		I	
	25 to 75							I			
75 to 100							I				
SK3201 to SK3202	Any	E2R									
	0 to 10				E2U	E2R					
	> 10				E2R						
	0 to 20							R		I	
	20 to 50							I			
	50 to 75								I		
75 to 100							I				
SK3401 to SK3403	Any	E2R									
	0 to 10				E2U	E2R					
	> 10				E2R						
	0 to 20							R		I	
	20 to 50							I			
	50 to 75								I		
75 to 100							I				
SK3501 to SK3507	Any	E2R									
	0 to 10										
	> 10										
	0 to 20							R		I	
	20 to 50							I			
	50 to 75								I		
75 to 100							I				
SK4201 to SK4203	Any	E2R									
	0 to 25								I		
	25 to 50								I		
	50 to 75							I		E2U	
	75 to 100							I		E2U	
SK4401 to SK4403	Any	E2R									
	0 to 25								I		
	25 to 50								I		
	50 to 75							I		E2U	
	75 to 100							I		E2U	

\* Included in the Accessory Kit Box.

**Table 6-11 Conformity size 4 to 6**

Drive	Motor cable length (m)	Filter and switching frequency			
		Internal		External	
		3kHz	6kHz	3kHz	6kHz
SK4601 to SK4606	Any	E2R			
	0 to 25			I	I
	25 to 50			I	E2U
	50 to 75			I	E2U
	75 to 100			I	E2U
SK5401 to SK5402	100	E2U			
	0 to 100			I	I
SK5601 to SK5602	100	E2R			
	0 to 25			I	I
	0 to 100			I	
SK6401 to SK6402	0 to 100	E2U			
	100 to max*	E2R			
	0 to 100			I	I
SK6601 to SK6602	0 to 100	E2U			
	100 to max*	E2R			
	0 to 25			I	I
	0 to 100			I	Do not use


\*See Chapter 8 *Motor cable lengths* on page 107 for maximum permitted length.

### 6.5.2 Compliance with EN 61800-3:2004 (standard for Power Drive Systems)

Meeting the requirements of this standard depends on the environment that the drive is intended to operate in, as follows:

#### Operation in the first environment

Observe the guidelines given in Compliance with generic emission standards section. An external EMC filter will always be required.



This is a product of the restricted distribution class according to IEC 61800-3

In a residential environment this product may cause radio interference in which case the user may be required to take adequate measures.

**CAUTION**


#### Operation in the second environment

In all cases a shielded motor cable must be used, and an EMC filter is required for all Commander SKs with a rated input current of less than 100A.

The drive contains an in-built filter for basic emission control. In some cases feeding the motor cables (U, V and W) once through a ferrite ring can maintain compliance for longer cable lengths. The requirements of operating in the second environment are met, depending on the motor cable length for 3kHz switching frequency as stated in Table 6-10 and Table 6-11.

**Key** (shown in decreasing order of permitted emission level):

- E2R EN 61800-3:2004 second environment, restricted distribution (Additional measures may be required to prevent interference)
- E2U EN 61800-3:2004 second environment, unrestricted distribution
- I Industrial generic standard EN 50081-2 (EN 61000-6-4:2007)  
EN 61800-3:2004 first environment restricted distribution (The following caution is required by EN 61800-3:2004)



This is a product of the restricted distribution class according to IEC 61800-3. In a residential environment this product may cause radio interference in which case the user may be required to take adequate measures.

**CAUTION**

- R Residential generic standard EN 50081-1 (EN 61000-6-3:2007)  
EN 61800-3:2004 first environment unrestricted distribution

EN 61800-3:2004 defines the following:

- The first environment is one that includes residential premises. It also includes establishments directly connected without intermediate transformers to a low-voltage power supply network which supplies buildings used for residential purposes.
- The second environment is one that includes all establishments other than those directly connected to a low-voltage power supply network which supplies buildings used for residential purposes.  
Restricted distribution is defined as a mode of sales distribution in which the manufacturer restricts the supply of equipment to suppliers, customers or users who separately or jointly have technical competence in the EMC requirements of the application of drives.

### 6.5.3 Overall external EMC filter dimensions

Table 6-12 Optional external EMC filter dimensions

CT part number	Manufacturer	Manufacturer's part number	Dimension			Weight	
			H	W	D	kg	lb
4200-6210	Schaffner	FS6008-32-07	428.5 mm (16.870 in)	155 mm (6.102 in)	55 mm (2.165 in)	2	4.4
4200-6305		FS6008-62-07	414 mm (16.299 in)	250 mm (9.842 in)	60 mm (2.362 in)	3.5	7.7
4200-6307		FS6008-75-07					
4200-6309		FS6008-30-07					
4200-6406		FS6008-101-35	300 mm (11.811 in)	225 mm (8.858 in)	100 mm (3.937 in)	4	8.8
4200-6408		FS6008-58-53		208 mm (8.189 in)		3.8	8.4
4200-6503		FS6008-164-40		249 mm (9.803 in)	120 mm (4.724 in)	6.8	15
4200-6504		FS6008-95-35		225 mm (8.858 in)	100 mm (3.937 in)	4.4	9.7
4200-6603		FS6008-260-99	295 mm (11.614 in)	230 mm (9.055 in)	136 mm (5.354 in)	5.25	11.6
4200-6604		FS6008-160-99	357 mm (14.055 in)	230 mm (9.055 in)	136 mm (5.354 in)	5.25	11.6
4200-6211		Epcos	B84143-A32-R207-1-7659	431.5 mm (16.988 in)	155 mm (6.102 in)	55 mm (2.165 in)	3.3
4200-6306	B84143-A75-R2071		425 mm (16.732 in)	250 mm (9.843 in)	60 mm (2.362 in)	5.1	11.2
4200-6308	B84143-A30-R207-1-7659						
4200-6405	B84143-A101-R207-51-76592		300 mm (11.811 in)	207 mm (8.150 in)	90 mm (3.543 in)	7.8	17.2
4200-6407	B84143-A58-R207-51-7659			205 mm (8.071 in)		8.0	17.6
4200-6501	B84143-A165-R207-53-76592			249 mm (9.803 in)	120 mm (4.724 in)	12.0	26.5
4200-6502	B84143-A165_A95-R207-51-7659		364 mm (14.331 in)	230 mm (9.055 in)	147 mm (5.787 in)	10.0	22.0
4200-6601	B84143-A260-S207-2-7659					8.6	19.0
4200-6602	B84143-A160-S207-2-7659						

### 6.5.4 External EMC filter torque settings size 2 to 6

Table 6-13 Optional external EMC filter terminal data

CT part number	Manufacturer	Power connections		Ground connections	
		Max cable size	Max torque	Ground stud size	Max torque
4200-6210	Schaffner	10mm <sup>2</sup> 8AWG	2.0 N m (1.5 lb ft)	M5	3.5 N m (2.6 lb ft)
4200-6305		16mm <sup>2</sup> 6AWG	2.2 N m (1.6 lb ft)	M6	3.9 N m (2.9 lb ft)
4200-6307					
4200-6309		50mm <sup>2</sup> 0AWG	8 N m (5.9 lb ft)	M10	25 N m (18.4 lb ft)
4200-6406					
4200-6408					
4200-6503		25mm <sup>2</sup> 4AWG	2.3 N m (1.7 lb ft)	M6	3.9 N m (2.9 lb ft)
4200-6504		95mm <sup>2</sup> 4/0AWG	20 N m (14.7 lb ft)	M10	25 N m (18.4 lb ft)
4200-6504		50mm <sup>2</sup> 0AWG	8 N m (5.9 lb ft)		
4200-6603					
4200-6604					
4200-6211	Epcos	10mm <sup>2</sup> 8AWG	1.35 N m (1.0 lb ft)	M5	3.0 N m (2.2 lb ft)
4200-6306		16mm <sup>2</sup> 6AWG	2.2 N m (1.6 lb ft)	M6	5.1 N m (3.8 lb ft)
4200-6308		10mm <sup>2</sup> 8AWG	1.35 N m (1.0 lb ft)		
4200-6405		50mm <sup>2</sup> 0AWG	6.8 N m (5.0 lb ft)	M10	10 N m (7.4 lb ft)
4200-6407		95mm <sup>2</sup> 4/0AWG	20 N m (14.7 lb ft)		
4200-6501					
4200-6502					
4200-6601					
4200-6602					

The external EMC filters for sizes 2 and 3 can be footprint or bookcase mounted, see Figure 6-5 and Figure 6-6. The external EMC filters for sizes 4 to 6 are designed to be mounted above the drive, as shown in Figure 6-7.

**NOTE**

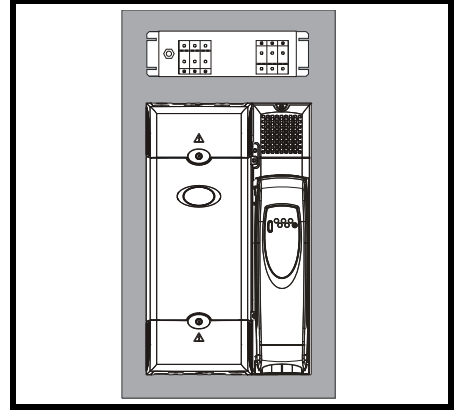
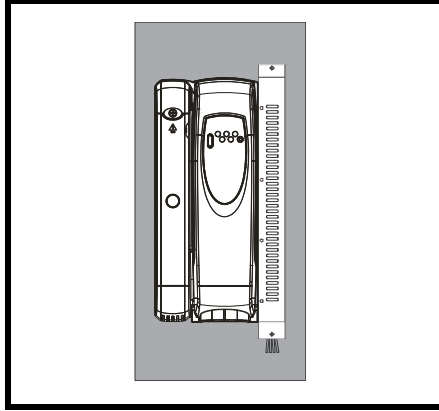
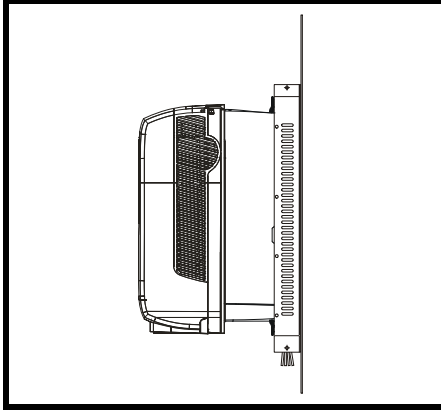
The installer of the drive is responsible for ensuring compliance with the EMC regulations that apply where the drive is to be used.

Mount the external EMC filter following the guidelines in section *Compliance with generic emission standards* on page 98.

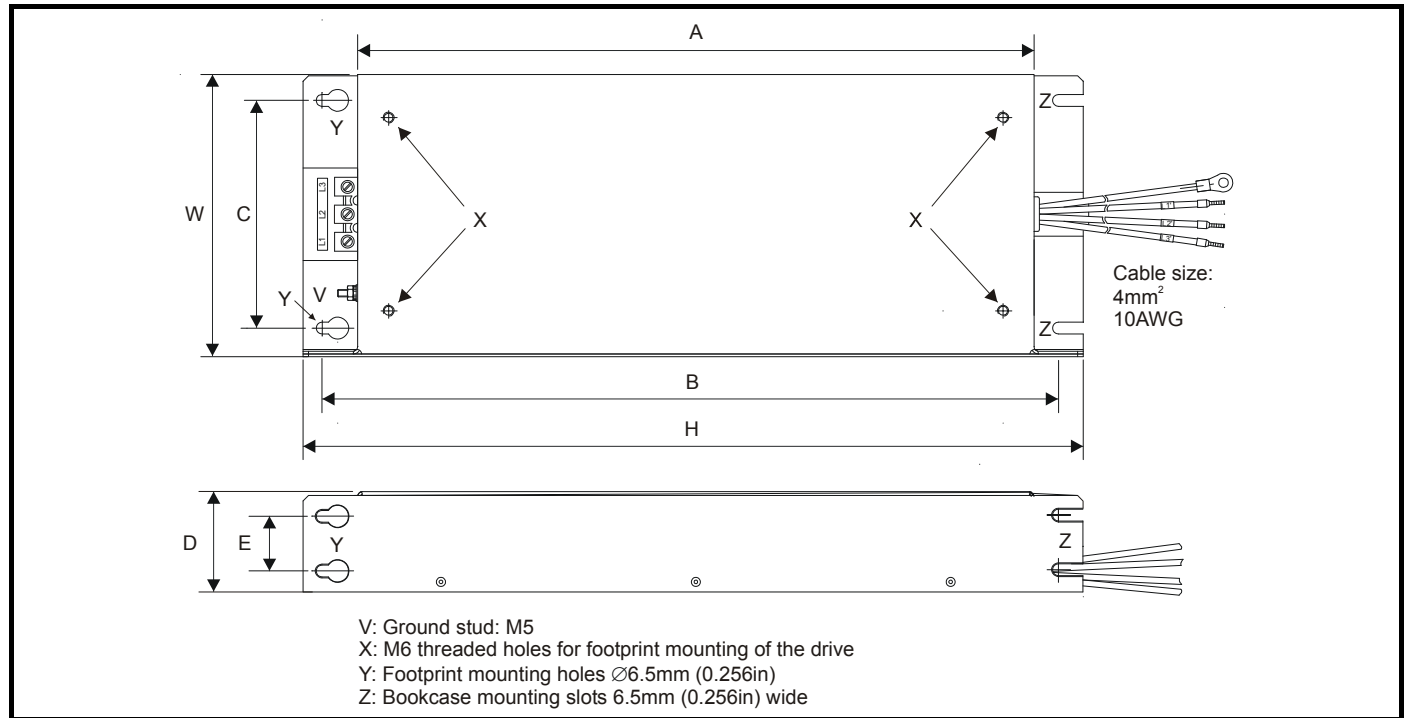
**High ground leakage current**  
 When an EMC filter is used, a permanent fixed ground connection must be provided which does not pass through a connector or flexible power cord. This includes the internal EMC filter.

**WARNING**

**Figure 6-5 Footprint mounting the EMC filter**   **Figure 6-6 Bookcase mounting the EMC filter**   **Figure 6-7 Size 4 to 6 mounting of EMC filter**



**Figure 6-8 Size 2 external EMC filter**

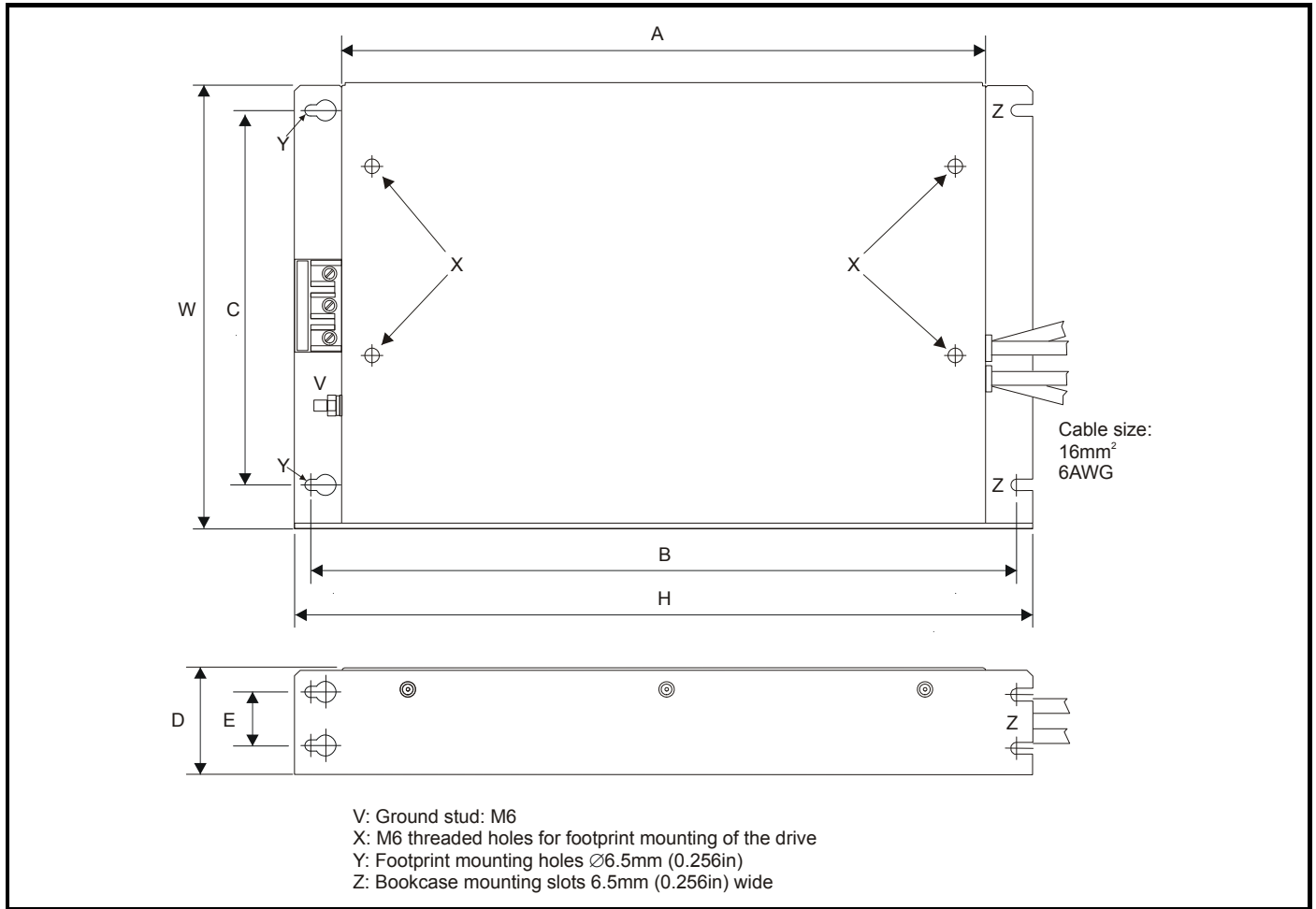


All filter mounting holes are suitable for M6 fasteners.

CT part no.	Manufacturer	A	B	C	D	E	H	W
4200-6210	Schaffner	371.5 mm (14.626 in)	404.5 mm (15.925 in)	125 mm (4.921 in)	55 mm (2.165 in)	30 mm (1.181 in)	428.5 mm (16.870 in)	155 mm (6.102 in)
4200-6211	Epcos						431.5 mm (16.988 in)	

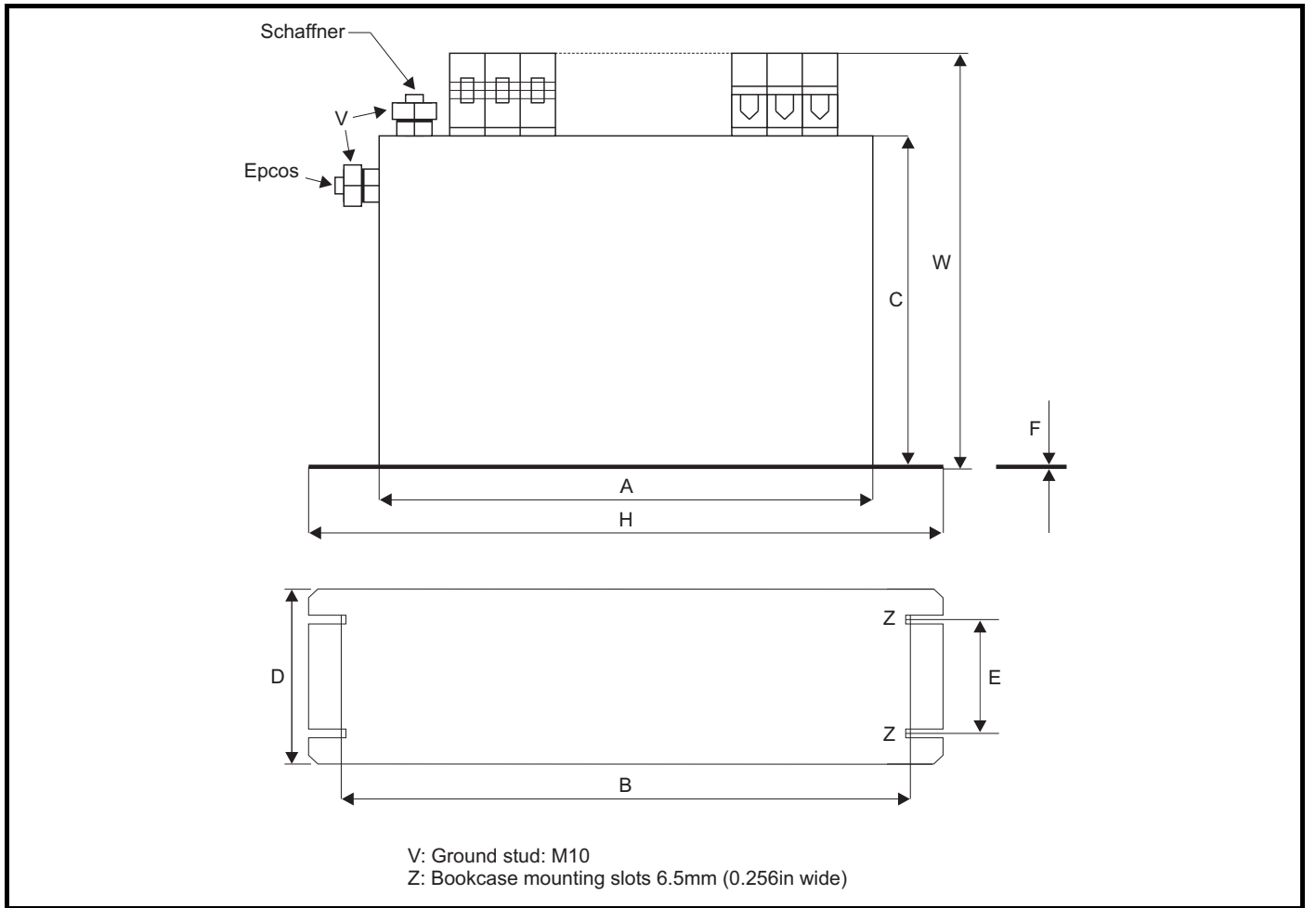


**Figure 6-9 Size 3 external EMC filter**



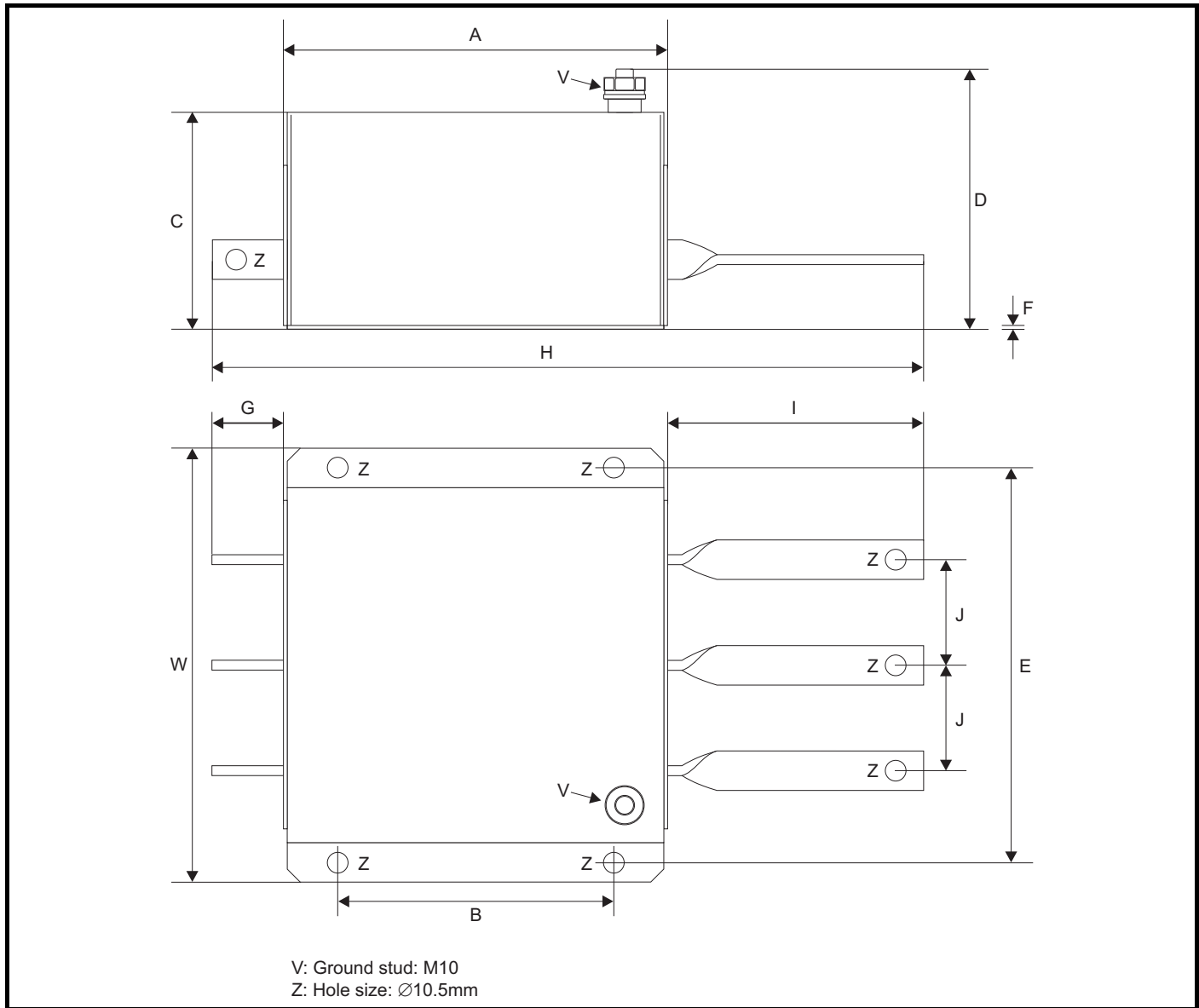
CT part no.	Manufacturer	A	B	C	D	E	H	W
4200-6305	Schaffner	361 mm (14.213 in)	396 mm (15.591 in)	210 mm (8.268 in)	60 mm (2.362 in)	30 mm (1.181 in)	414 mm (16.299 in)	250 mm (9.843 in)
4200-6307								
4200-6309								
4200-6306	Epcos	365 mm (14.370 in)					425 mm (16.732 in)	
4200-6308								

**Figure 6-10 Size 4 and 5 external EMC filter**



CT part no.	Manufacturer	A	B	C	D	E	F	H	W
4200-6406	Schaffner	260 mm (10.236 in)	275 mm (10.827 in)	170 mm (6.693 in)	100 mm (3.937 in)	65 mm (2.559 in)	1.5 mm (0.059in)	300 mm (11.811 in)	225 mm (8.858 in)
4200-6408					120 mm (4.724 in)	85 mm (3.346 in)			208 mm (8.189 in)
4200-6503					100 mm (3.937 in)	65 mm (2.559 in)			249 mm (9.803 in)
4200-6504					150 mm (5.906 in)	90 mm (3.543in)			65 mm (2.559 in)
4200-6405	Epcos	260 mm (10.236 in)	275 mm (10.827 in)	170 mm (6.693 in)	90 mm (3.543in)	65 mm (2.559 in)	2 mm (0.079 in)	300 mm (11.811 in)	205 mm (8.071 in)
4200-6407					120 mm (4.724 in)	85 mm (3.346 in)	1 mm (0.039 in)		249 mm (9.803 in)
4200-6501									
4200-6502									

**Figure 6-11 Size 6 external EMC filter**



CT part no.	Manufacturer	A	B	C	D	E	F	G	H	I	J	W
4200-6603	Schaffner	191 mm (7.717 in)	140 mm (5.512 in)	110 mm (4.331 in)	136 mm (5.354 in)	210 mm (8.268 in)	2 mm (0.079 in)	38 mm (1.496 in)	295 mm (11.614 in)	66 mm (2.958 in)	53.5 mm (2.106 in)	230 mm (9.055 in)
4200-6604				108 mm (4.252 in)	147 mm (5.787 in)			36.5 mm (1.437 in)	357 mm (14.055 in)	128 mm (5.039 in)		
4200-6601	Epcos	200 mm (7.874 in)	140 mm (5.512 in)	108 mm (4.252 in)	147 mm (5.787 in)	210 mm (8.268 in)	2 mm (0.079 in)	36.5 mm (1.437 in)	364 mm (14.331 in)	127 mm (5.000 in)	53.5 mm (2.106 in)	230 mm (9.055 in)
4200-6602				108 mm (4.252 in)	147 mm (5.787 in)			36.5 mm (1.437 in)	364 mm (14.331 in)	127 mm (5.000 in)		

### 6.5.5 Compatibility of Commander SK EMC filters with IT supplies

Table 6-14 shows the maximum IT supply voltages allowed when using Schaffner EMC filters with Commander SK size A to D.

**Table 6-14 Maximum IT supply voltages**

Drive	Filter part number		Maximum IT supply (Vac)
	CT	Schaffner	
SKA1100025, SKA1100037, SKA1200025, SKA1200037, SKA1200055 & SKA1200075	4200-6122	FS6512-12-07	300
SKA1100025, SKA1100037, SKA1200025, SKA1200037, SKA1200055 & SKA1200075	4200-6123	FS6512-12-07-LL	250
SKBD200110 & SKBD200150	4200-6212	FS6513-20-07	300
SKBD200110 & SKBD200150. SKB3400037 to SKB3400150.	4200-6213	FS6513-10-07	420
SKBD200110 & SKBD200150	4200-6214	FS6513-20-07-LL	250
SKBD200110 & SKBD200150. SKB3400037 to SKB3400150.	4200-6215	FS6513-10-07-LL	485
SKB1100075 & SKB1100110	4200-6216	FS6513-27-07	300
SKCD200220, SKC3400220 to SKC3400400	4200-6217	FS6514-14-07-LL	485
SKCD200220	4200-6310	FS6514-24-07	300
SKCD200220, SKC3400220 to SKC3400400	4200-6311	FS6514-14-07	420
SKCD200220	4200-6312	FS6514-24-07-LL	250
SKDD200300	4200-6409	FS6515-24-07	300
SKDD200300	4200-6410	FS6515-24-07-LL	250
SKDD200300, SKD3200400, SKD3400550 & SKD3400750	4200-6411	FS6515-16-07	420
SKDD200300, SKD3200400, SKD3400550 & SKD3400750	4200-6412	FS6515-16-07-LL	485

Table 6-15 shows the maximum IT supply voltages allowed when using Schaffner EMC filters with Commander SK size 2 to 6

**Table 6-15 Maximum IT supply voltages**

Drive	Filter part number		Maximum IT supply (Vac)
	CT	Schaffner	
SK2201 to SK2203	4200-6210	FS6008-32-07	300
SK2401 to SK2404	4200-6210	FS6008-32-07	NC
SK2401	4200-6219	FS24082-16-07-1	440
SK2403 & SK2404	4200-6220	FS24082-28-07-1	440
SK3401	4200-6221-01	FS24082-40-07-1	440
SK3401 to SK3403	4200-6305	FS6008-62-07	400
SK3201 to SK3202	4200-6307	FS6008-75-07	420
SK3501 to SK3507	4200-6309	FS6008-30-07	600
SK4201 to SK4203, SK4401 to SK4403	4200-6406	FS6008-101-35	420
SK4601 to SK4606	4200-6408	FS6008-58-53	400
SK5401 to SK5402	4200-6503	FS6008-164-40	435
SK5601 to SK5602	4200-6504	FS6008-95-35	585
SK6401 to SK6402	4200-6603	FS6008-260-99	450
SK6601 to SK6602	4200-6604	FS6008-160-99	605

Table 6-16 shows the maximum IT supply voltages allowed when using Epcos EMC filters with Commander SK size 2 to 6.

**Table 6-16 Maximum IT supply voltages**

Drive	Filter part number		Maximum IT supply (Vac)
	CT	Epcos	
SK2201 to SK2203, SK2401 to SK2404	4200-6211	B84143-A32-R207-1	480
SK3201 to SK3202, SK3401 to SK3403	4200-6306	B84143-A75-R207	480
SK3501 to SK3507	4200-6308	B84143-A30-R207	660
SK4201 to SK4203, SK4401 to SK4403	4200-6405	B84143-A101-R207	480
SK4601 to SK4606	4200-6407	B84143-A58-R207	660
SK5401 to SK5402	4200-6501	B84143-A165-R207	480
SK5601 to SK5602	4200-6502	B84143-A95-R207	630
SK6401 to SK6402	4200-6601	B84143-A260-S207	480
SK6601 to SK6602	4200-6602	B84143-A160-S207	480

**Surge immunity of control circuits - long cables and connections outside a building**

The input/output ports for the control circuits are designed for general use within machines and small systems without any special precautions. These circuits meet the requirements of EN 61000-6-2:2005 (1kV surge) provided the 0V connection is not grounded.

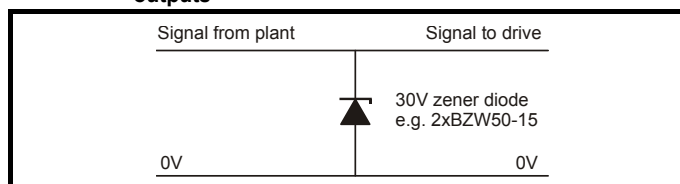
In applications where they may be exposed to high-energy voltage surges, some special measures may be required to prevent malfunction or damage. Surges may be caused by lightning or severe power faults in association with grounding arrangements which permit high transient voltages between nominally grounded points. This is a particular risk where the circuits extend outside the protection of a building.

As a general rule, if the circuits are to pass outside the building where the drive is located, or if cable runs within a building exceed 30m, some additional precautions are advisable. One of the following techniques should be used:

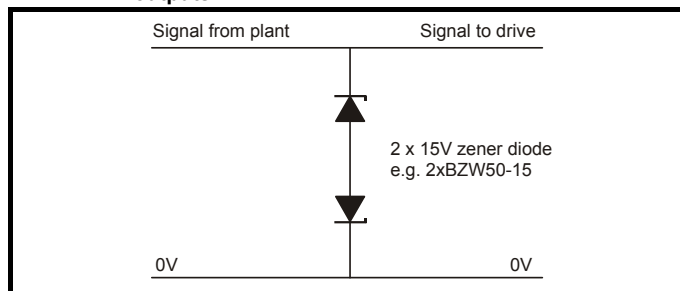
- Galvanic isolation, i.e. do not connect the control 0V terminal to ground. Avoid loops in the control wiring, i.e. ensure every control wire is accompanied by its return (0V) wire.
- Shielded cable with additional power ground bonding. The cable shield may be connected to ground at both ends, but in addition the ground conductors at both ends of the cable must be bonded together by a power ground cable (equipotential bonding cable) with cross-sectional area of at least 10mm<sup>2</sup>, or 10 times the area of the signal cable shield, or to suit the electrical safety requirements of the plant. This ensures that fault or surge current passes mainly through the ground cable and not in the signal cable shield. If the building or plant has a well-designed common bonded network this precaution is not necessary.
- Additional over-voltage suppression - for the analog and digital inputs and outputs, a zener diode network or a commercially available surge suppressor may be connected in parallel with the input circuit as shown in Figure 6-12 and Figure 6-13.

If a digital port experiences a severe surge its protective trip may operate (O.Ld1 trip code 26). For continued operation after such an event, the trip can be reset automatically by setting Pr 10.34 to 5.

**Figure 6-12 Surge suppression for digital and unipolar inputs and outputs**



**Figure 6-13 Surge suppression for analog and bipolar inputs and outputs**



Surge suppression devices are available as rail-mounting modules, e.g. from Phoenix Contact:

- Unipolar TT-UKK5-D/24 DC
- Bipolar TT-UKK5-D/24 AC

These devices are not suitable for encoder signals or fast digital data networks because the capacitance of the diodes adversely affects the signal. Most encoders have galvanic isolation of the signal circuit from the motor frame, in which case no precautions are required. For data networks, follow the specific recommendations for the particular network.

**Compliance with generic emission standards**

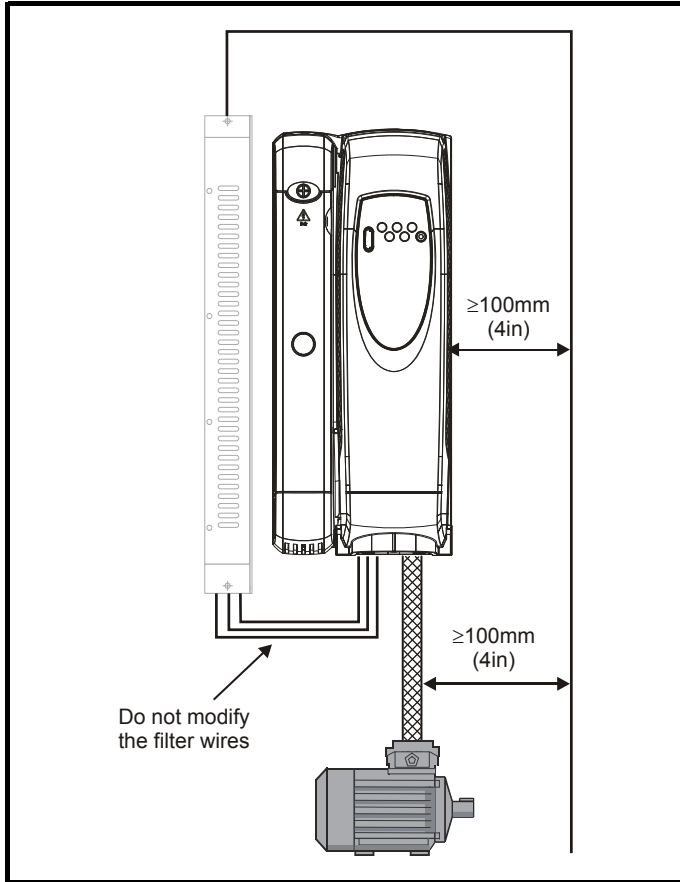
The following information applies to frame sizes A to D and 2 to 5.

Size 6 does not comply with the requirements of the generic standards for radiated emission.

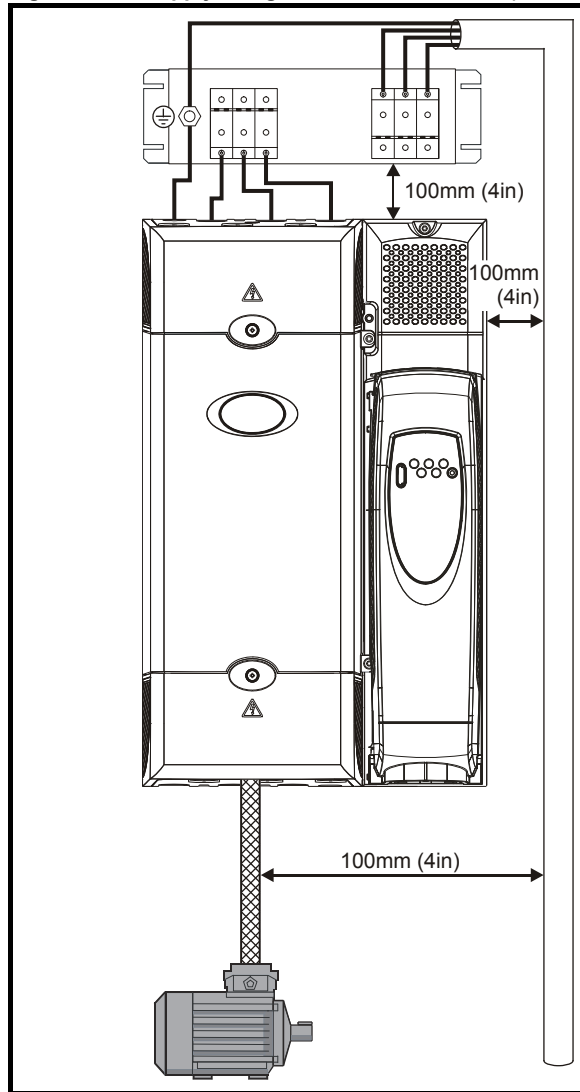
Size 6 complies with the requirements for conducted emission.

Use the recommended filter and shielded motor cable. Observe the layout rules given in Figure 6-14. Ensure the AC supply and ground cables are at least 100mm from the power module and motor cable.

**Figure 6-14 Supply and ground cable clearance (size 2 to 3)**

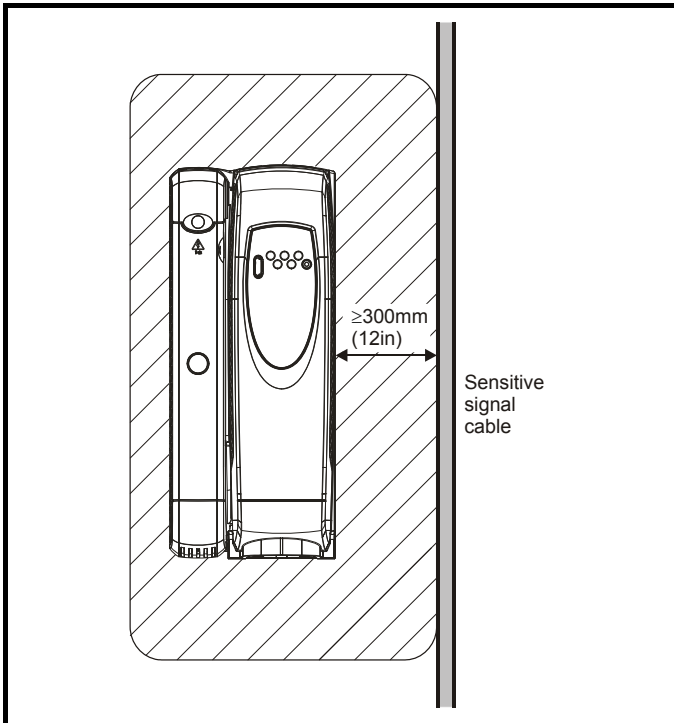


**Figure 6-15 Supply and ground cable clearance (size 4 to 6)**



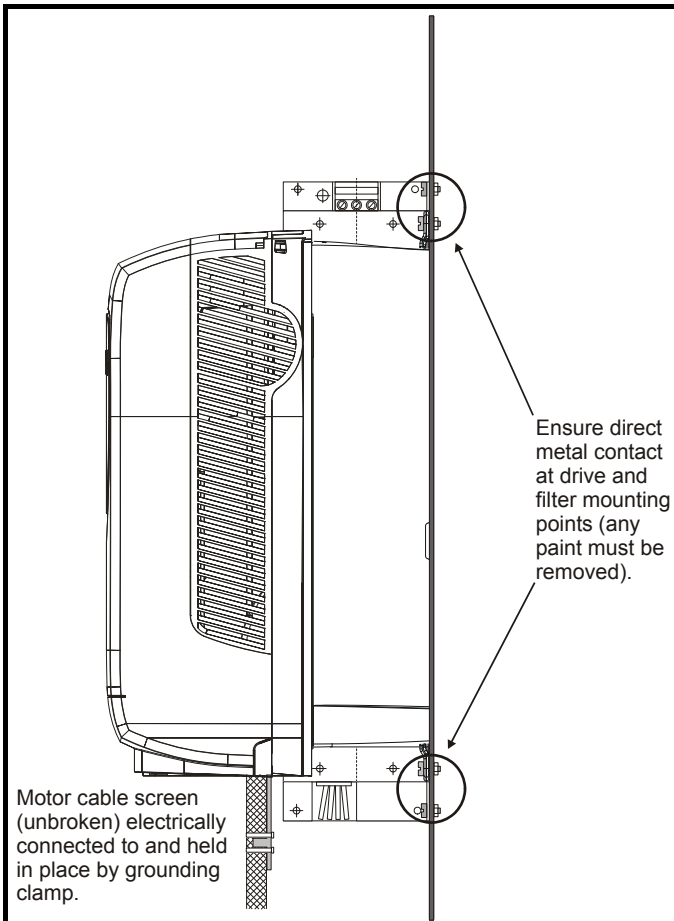
Avoid placing sensitive signal circuits in a zone 300mm (12in) all around the power module.

**Figure 6-16 Sensitive signal circuit clearance**



Ensure good EMC grounding.

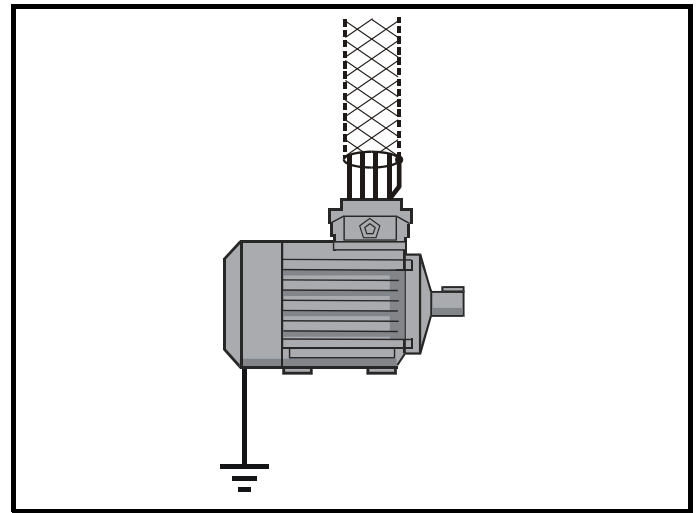
**Figure 6-17 Grounding the drive, motor cable shield and filter**



Connect the shield of the motor cable to the ground terminal of the motor frame using a link that is as short as possible and not exceeding 50mm (2in) long. A full 360° termination of the shield to the terminal housing of the motor is beneficial.

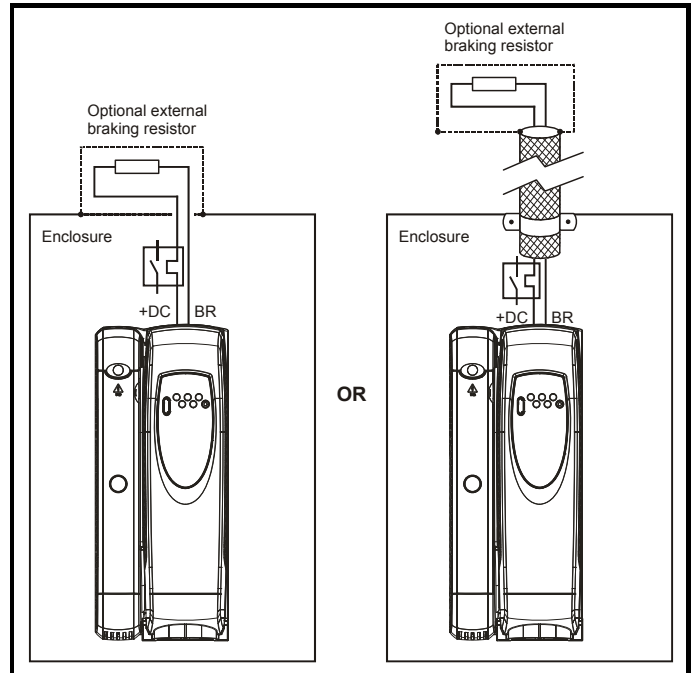
It is unimportant for EMC purposes whether the motor cable contains an internal (safety) ground core, or there is a separate external ground conductor, or grounding is through the shield alone. An internal ground core will carry a high noise current and therefore it must be terminated as close as possible to the shield termination.

**Figure 6-18 Grounding the motor cable shield**



Unshielded wiring to the optional braking resistor(s) may be used, provided the wiring does not run external to the enclosure. Ensure a minimum spacing of 300mm (12in) from signal wiring and the AC supply wiring to the external EMC filter. Otherwise this wiring must be shielded.

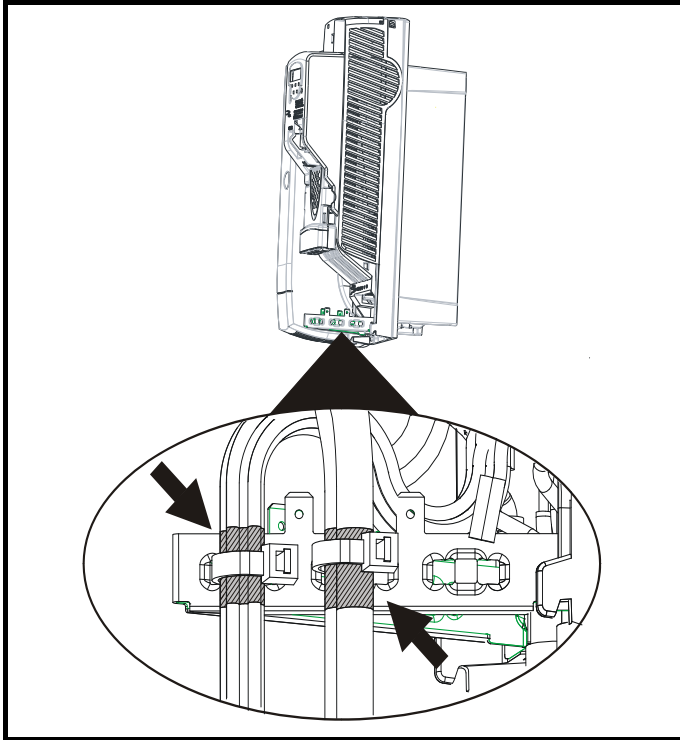
**Figure 6-19 Shielding requirements of optional external braking resistor**



If the control wiring is to leave the enclosure, it must be shielded and the shield(s) clamped to the drive using the grounding bracket as shown in Figure 6-20. Remove the outer insulating cover of the cable to ensure the shield(s) make contact with the bracket, but keep the shield(s) intact until as close as possible to the terminals

Alternatively, wiring may be passed through a ferrite ring, part no. 3225-1004.

**Figure 6-20** Grounding of signal cable shields using the grounding bracket



### Variations in the EMC wiring Interruptions to the motor cable

The motor cable should ideally be a single length of shielded or armored cable having no interruptions. In some situations it may be necessary to interrupt the cable, as in the following examples:

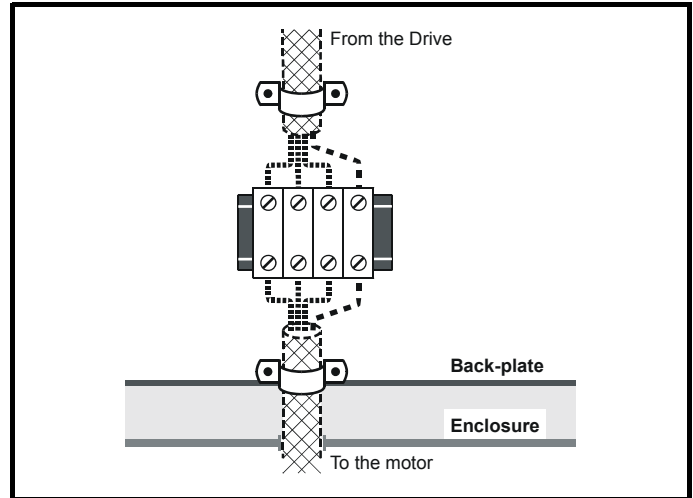
- Connecting the motor cable to a terminal block in the drive enclosure
- Fitting a motor isolator switch for safety when work is done on the motor

In these cases the following guidelines should be followed.

### Terminal block in the enclosure

The motor cable shields should be bonded to the back-plate using uninsulated metal cable-clamps which should be positioned as close as possible to the terminal block. Keep the length of power conductors to a minimum and ensure that all sensitive equipment and circuits are at least 0.3m (12 in) away from the terminal block.

**Figure 6-21** Connecting the motor cable to a terminal block in the enclosure



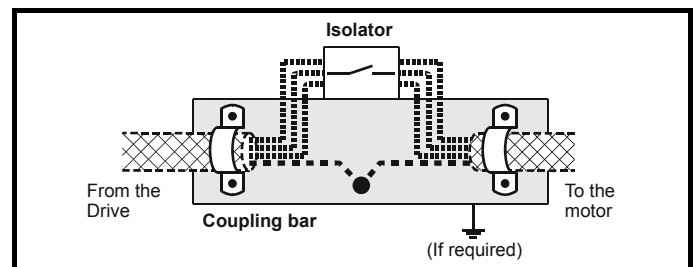
### Using a motor isolator-switch

The motor cable shields should be connected by a very short conductor having a low inductance. The use of a flat metal coupling-bar is recommended; conventional wire is not suitable.

The shields should be bonded directly to the coupling-bar using uninsulated metal cable-clamps. Keep the length of the exposed power conductors to a minimum and ensure that all sensitive equipment and circuits are at least 0.3m (12 in) away.

The coupling-bar may be grounded to a known low-impedance ground nearby, for example a large metallic structure which is connected closely to the drive ground.

**Figure 6-22** Connecting the motor cable to an isolator switch



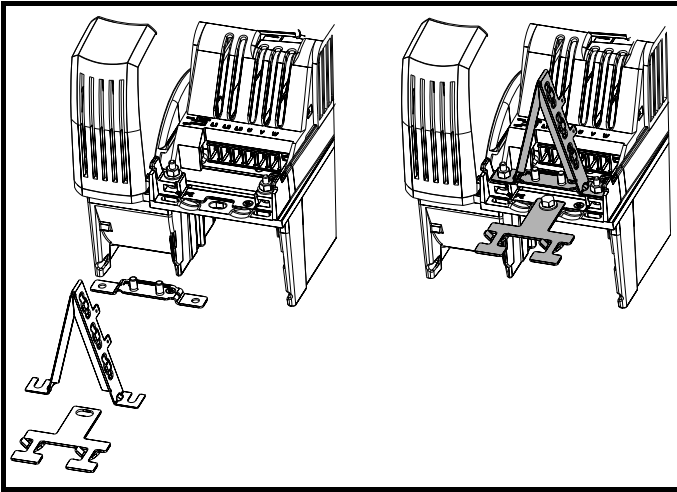
### Grounding hardware

The Commander SK size 2 and 3 are provided with a grounding bracket and grounding clamp. They can be used as cable management bracket/clamp or they can be used to facilitate EMC compliance. They provide a convenient method for direct grounding of cable shields without the use of 'pig tails'. Cable shields can be bared and clamped to the grounding bracket using metal clips or clamps\* (not supplied) or cable ties. Note that the shield must in all cases be continued through the cable clamp to the intended terminal on the drive, in accordance with the connection details for the specific signal.

\*A suitable clamp is the Phoenix DIN rail mounted SK14 cable clamp (for cables with a maximum outer diameter of 14mm).



**Figure 6-23 Fitting the grounding clamp**

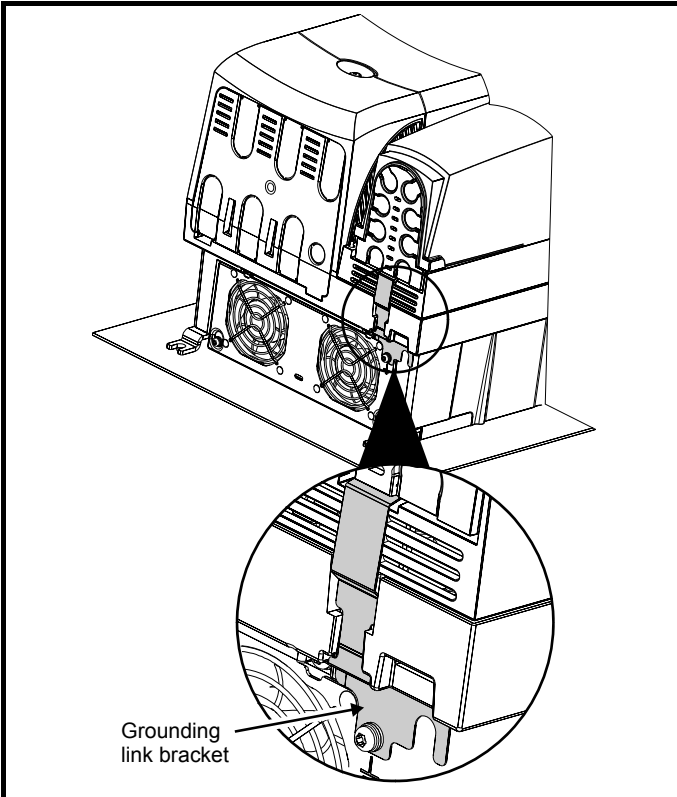


A faston tab is located on the grounding bracket for the purpose of connecting the drive 0V to ground should the user require to do so.

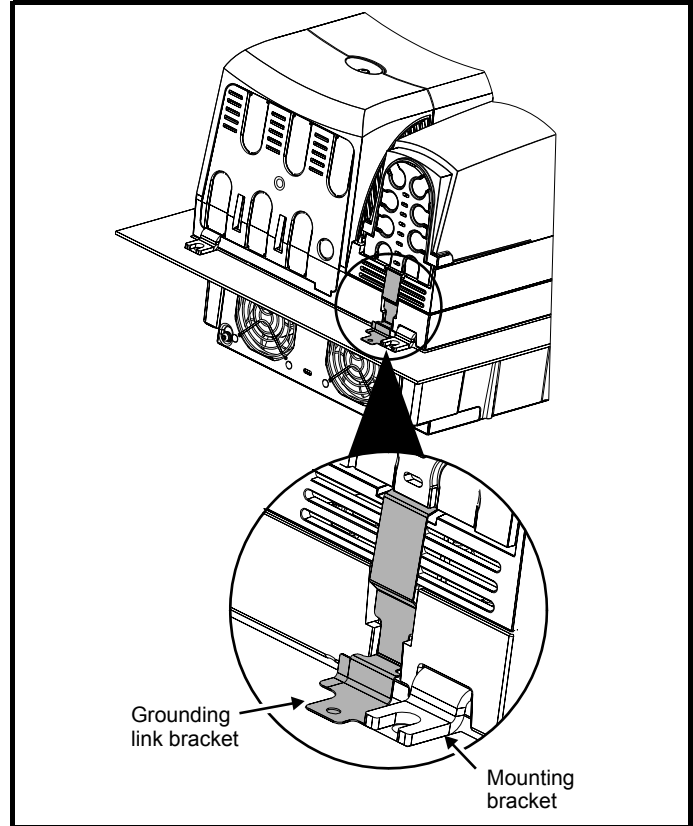
**WARNING** On Commander SK size 2, the grounding bracket is secured using the power ground terminal of the drive. Ensure that the supply ground connection is secure after fitting/removing the grounding bracket. Failure to do so will result in the drive not being grounded.

When a Commander SK size 4 or 5 is through-panel mounted, the grounding link bracket must be folded upwards. A screw can be used to secure the bracket or it can be located under the mounting bracket to ensure that a good ground connection is made. This is required to provide a grounding point for the grounding bracket as shown in Figure 6-24.

**Figure 6-24 Grounding link bracket in its surface mount position (as supplied)**



**Figure 6-25 Grounding link bracket folded up into its through-panel mount position**



**Internal EMC filter**

It is recommended that the internal EMC filter be kept in place unless there is a specific reason for removing it.

**WARNING** On Commander SK size 3, 4, 5 and 6, when used with ungrounded (IT) supplies, the internal EMC filter must be removed unless additional motor ground fault protection is installed or, in the case of size 3 only, the external EMC filter is also used.

**Table 6-17 Behavior of the drive in the event of a motor circuit ground (earth) fault with an IT supply**

Drive size	Internal filter only	External filter (with internal)
2	Drive trips on fault	Drive trips on fault
3	May not trip – precautions required	Drive trips on fault
4 to 6	May not trip – precautions required	May not trip – precautions required

For instructions on removal, refer to Figure 6-2 and Figure 6-3.

**Use of earth (ground) leakage circuit breakers (ELCB) / residual current device (RCD)**

There are three common types of ELCB/RCD:

- Type AC** - detects AC fault currents
- Type A** - detects AC and pulsating DC fault currents (provided the DC current reaches zero at least once every half cycle)
- Type B** - detects AC, pulsating DC and smooth DC fault currents

- Type AC should never be used with drives
- Type A can only be used with single phase drives
- Type B must be used with three phase drives

**Further EMC precautions**

Further EMC precautions are required if more stringent EMC emission requirements apply:

- Operation in the first environment
- Conformity to the generic emission standards

- Equipment which is sensitive to electrical interference operating nearby

In this case it is necessary to use:

The optional external EMC filter

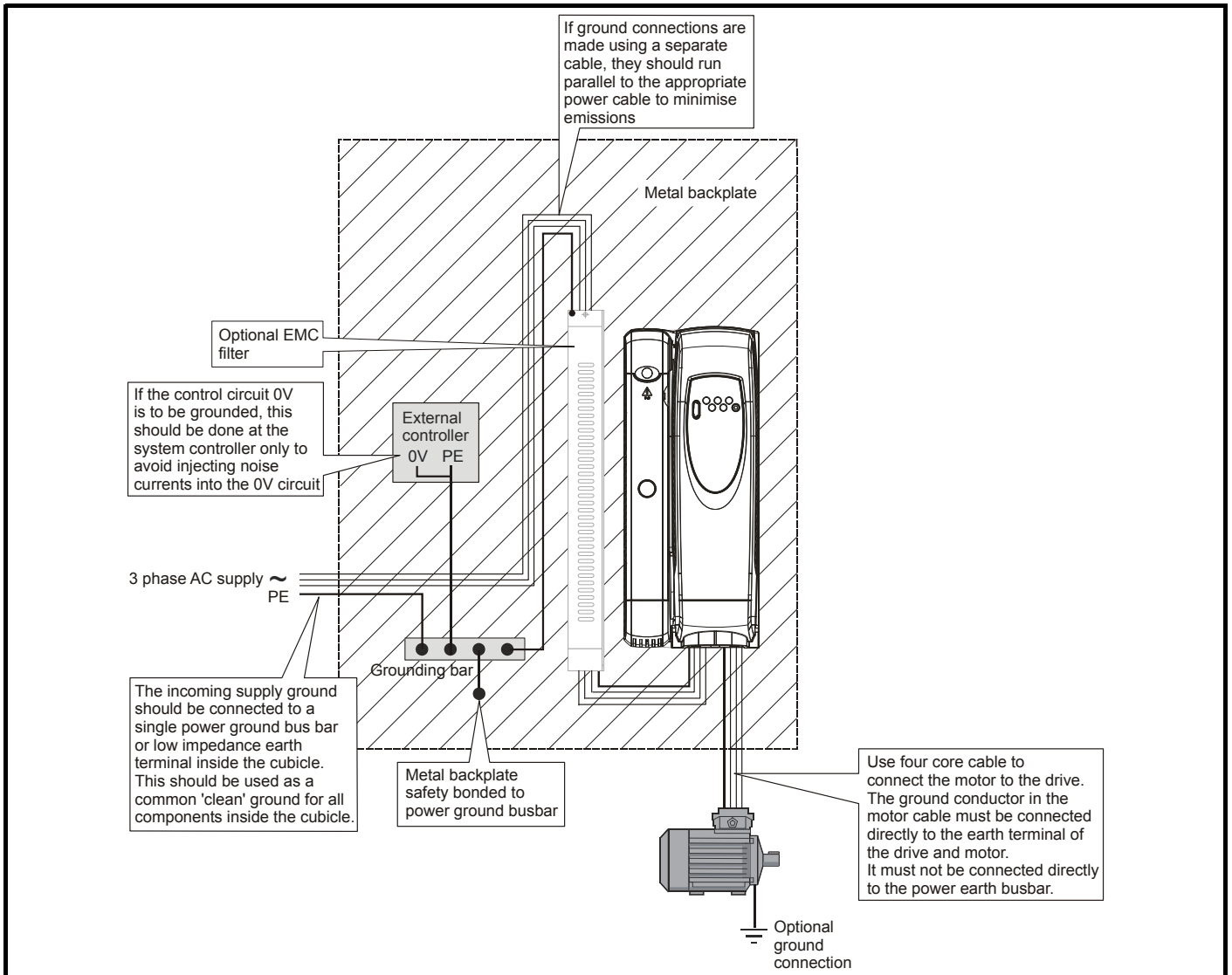
- A shielded motor cable, with the shield clamped to the grounded metal panel
- A shielded control cable, with the shield clamped to the grounded metal panel
- A full range of external EMC filters is also available for use with Commander SK.

### General requirements for EMC Ground (earth) connections

The grounding arrangements should be in accordance with Figure 6-26, which shows a single drive on a back-plate with or without an additional enclosure.

Figure 6-26 shows how to manage EMC when using an unshielded motor cable. However a shielded cable is preferable, in which case it should be installed as shown in section *Compliance with generic emission standards* on page 98.

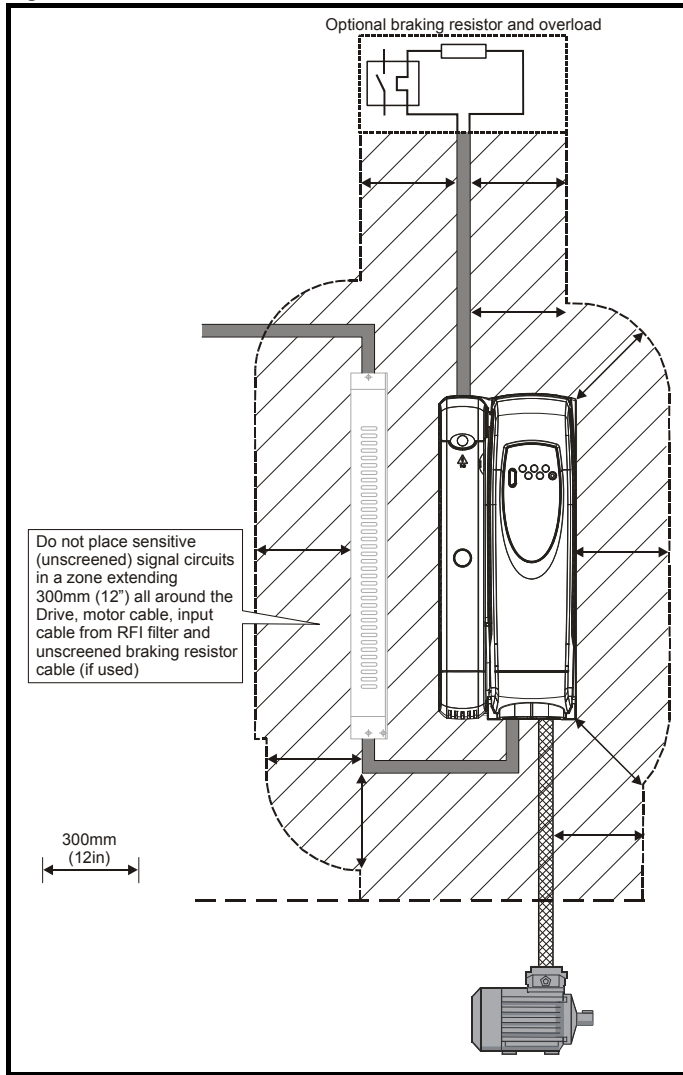
**Figure 6-26 General EMC enclosure layout showing ground connections**



### Cable layout

Figure 6-27 indicates the clearances which should be observed around the drive and related 'noisy' power cables by all sensitive control signals / equipment.

**Figure 6-27 Drive cable clearances**



**NOTE**

Any signal cables which are carried inside the motor cable (i.e. motor thermistor, motor brake) will pick up large pulse currents via the cable capacitance. The shield of these signal cables must be connected to ground close to the motor cable, to avoid this noise current spreading through the control system.

## 7 AC line reactors

Table 7-1 AC line reactor values

Drives used with	Reactor part number	Input phases	Inductance	Continuous rms current	Peak current	Weight	Dimensions		
			mH	A	A	kg	L	D	H
SKA1200025	4402-0224	1	2.25	6.5	13	0.8	72	65	90
SKA1200037									
SKA1200055	4402-0225	1	1.0	15.1	30.2	1.1	82	75	100
SKA1200075									
SKBD200110									
SKBD200150	4402-0226	1	0.5	26.2	52.4	1.5	82	90	105
SKCD200220									
SKDD200300									
SKBD200110	4402-0228	3	1.0	15.4	47.4	3.8	150	90	150
SKBD200150									
SKCD200220	4402-0229	3	0.4	24.6	49.2	3.8	150	90	150
SKB3400037	4402-0227	3	2.0	7.9	15.8	3.5	150	90	150
SKB3400055									
SKB3400075									
SKB3400110									
SKB3400150									
SKC3400220	4402-0228	3	1.0	15.4	47.4	3.8	150	90	150
SKC3400300									
SKC3400400									
SKDD200300									
SKD3400550									
SKD3400750									
SK2201									
SK2401									
SK2202	4402-0229	3	0.4	24.6	49.2	3.8	150	90	150
SKD3200400	4402-0232	3	0.6	27.4	54.8	6	180	100	190
SK2402									
SK2403	4400-0240**	3	0.45	46	92	11	190	150	225
SK2404									
SK3401									
SK3402									
SK2203	4400-0241**	3	0.3	74	148	15	250	150	275
SK3201*									
SK3202*									
SK4201*									
SK3403									
SK4401									

### NOTE

Commander SK sizes D, 2, 3 and 4 drives include DC chokes, AC reactors are only required for harmonic reduction.

### NOTE

\*The reactance values will be higher than 2% with these drives, which may result in a loss of drive output (reduced torque at high speed) because of the voltage drop.

\*\* These input reactors are not stocked by Control Techniques. Contact your local Drive Centre. The AC line reactors for the 110V drives should be sourced locally.

## 7.1 Line reactors

Input line reactors reduce the risk of damage to the drive resulting from poor phase balance or severe disturbances on the supply network.

Where line reactors are to be used, reactance values of approximately 2% are recommended. Higher values may be used if necessary, but may result in a loss of drive output (reduced torque at high speed) because of the voltage drop.

For all drive ratings, 2% line reactors permit drives to be used with a supply imbalance of up to 3.5% negative phase sequence (equivalent to 5% voltage imbalance between phases).

Severe disturbances may be caused by the following factors, for example:

- Power factor correction equipment connected close to the drive.
- Large DC drives having no or inadequate line reactors connected to the supply.
- Direct-on-line started motor(s) connected to the supply such that when any of these motors are started, the voltage dip exceeds 20%.

Such disturbances may cause excessive peak currents to flow in the input power circuit of the drive. This may cause nuisance tripping, or in extreme cases, failure of the drive.

Drives of low power rating may also be susceptible to disturbance when connected to supplies with a high rated capacity.

Model size D and SK2201 to SK4606 have an internal DC choke, while models SK5401 to SK6602 have internal AC line chokes. Therefore, they do not require AC line reactors except for cases of excessive phase unbalance or extreme supply conditions.

When required, each drive must have its own reactor(s). Three individual reactors or a single three-phase reactor should be used.

**NOTE**

EMC filters do not give adequate protection against these conditions.

## 7.2 Reactor current ratings

### Continuous current:

Not less than the continuous input current rating of the drive.

### Repetitive peak current rating:

Not less than twice the continuous input current rating of the drive.

### Voltage fluctuation (Flicker) standard EN 61000-3-3:2008 (IEC61000-3-3)

Those models that fall within the scope of EN 61000-3-3:2008, as stated in the Declaration of Conformity, conform to the requirements for manual switching, i.e. the voltage dip caused when a drive at room temperature is switched on is within the permitted limits.

The drive does not of itself cause periodic voltage fluctuation in normal operation. The installer must ensure that the control of the drive is such that periodic fluctuations in supply current do not infringe the flicker requirements where applicable. Note that large periodic load fluctuations in the frequency range of between 1Hz and 30Hz are particularly inclined to cause irritating lighting flicker and are subject to stringent limits under EN 61000-3-3:2008.

## 7.3 Input line reactors for harmonics standards EN 61000-3-2:2006 and IEC61000-3-2

The following input line reactors allow the Commander SK 0.25 - 0.55kW drives to conform to harmonic standards EN 61000-3-2:2006 and IEC61000-3-2.

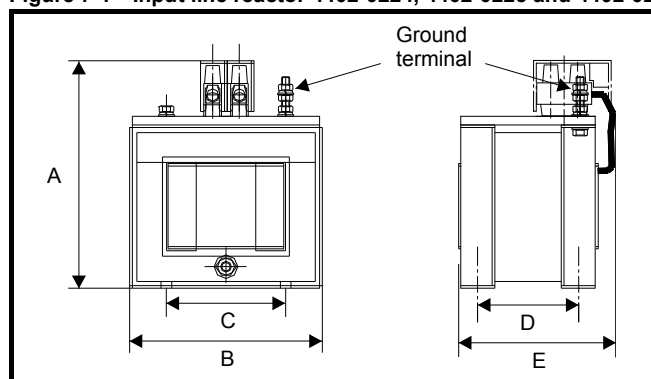
**Table 7-2 Input line reactors for harmonics standards EN 61000-3-2:2006 and IEC61000-3-2**

Drive	Reactor part number	Drive power de-rating	Input power	Inductance	Continuous rms current
			W	mH	
SKA1200025	4400-0239	None	374	4.5	2.4
SKA1200037	4400-0238	None	553	9.75	3.2
SKA1200055	4400-0237	18%	715	16.25	4.5

EN 61000-3-2:2006 and IEC61000-3-2 applies to equipment with a supply voltage of 230VAC and a line current up to 16A, single or three phase. Professional equipment with rated input power exceeding 1kW has no limits - this applies to the 0.75kW drive.

Further information on EN 61000-3-2:2006 and IEC61000-3-2 is included on the EMC data sheets available from your local Control Techniques drive centre or distributor.

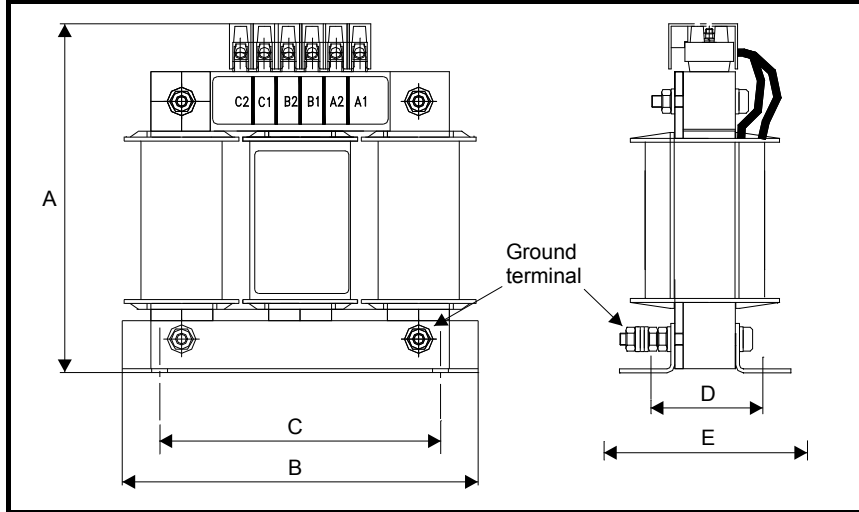
**Figure 7-1 Input line reactor 4402-0224, 4402-0225 and 4402-0226**



**Table 7-3 Dimensions**

Part No	Dimensions						Ground terminal
	A	B	C	D	E	Mounting hole	
4402-0224	90mm (3.54in)	72mm (2.84in)	44.5mm (1.75in)	35mm (1.38in)	65mm (2.56in)	8mm x 4mm (0.32in x 0.16in)	M3
4402-0225	100mm (3.94in)	82mm (3.23in)	54mm (2.13in)	40mm (1.58in)	75mm (2.95in)		
4402-0226	105mm (4.13in)			53mm (2.09in)	90mm (3.54in)		

**Figure 7-2 Input line reactor 4402-0227, 4402-0228, 4402-0229**



**Table 7-4 Dimensions**

Part No	Dimensions						Ground terminal
	A	B	C	D	E	Mounting slot	
4402-0227	150mm (5.91in)	150mm (5.91in)	120mm (4.72in)	47mm (1.85in)	90mm (3.54in)	17mm x 7 mm (0.67in x 0.28in)	M5
4402-0228							
4402-0229							

### 7.3.1 Input Inductor calculation

To calculate the inductance required (at Y%), use the following equation:

$$L = \frac{Y}{100} \times \frac{V}{\sqrt{3}} \times \frac{1}{2\pi f I}$$

Where:

- I = drive rated input current (A)
- L = inductance (H)
- f = supply frequency (Hz)
- V = voltage between lines

The standard IEC 61000-3-12 and BS EN 61000-3-12:2005 apply to harmonic emissions from equipment rated 16A to 75A (input rated line current). Therefore this affects Commander SKD / SK2 upwards. Refer to the corresponding Commander SK EMC datasheet, which includes the information on the required additional external A.C. input line chokes to meet the standard.

## 8 Motor cable lengths

### 8.1 Commander SK size A to D

Table 8-1 Motor cable lengths

Drive frame size	kW rating	Maximum motor cable length
A	0.25 and 0.37	50m
	0.55 and 0.75	75m
B		100m
C		100m
D		100m

The capacitive loading of the drive by the motor cable means that the cable length limits shown in table 8-1 must be observed. Failure to do so can result in spurious OI.AC tripping of the drive. If longer cable lengths are required, consult your local Drive Centre or Distributor.

The maximum cable lengths were measured using cable with capacitance of 130pF/m.

This capacitance was measured by taking one phase as one node and the shield (screen) and ground (earth) (if any) as the other node, then measuring the capacitance between the two points.

### 8.2 Commander SK size 2 to 6

Table 8-2 Maximum motor cable lengths (200V drives)

200V Nominal AC supply voltage			
Model	Maximum permissible motor cable length for each of the following frequencies		
	3kHz	6kHz	12kHz
SK2201	200m (660ft)	100m (330ft)	50m (165ft)
SK2202			
SK2203			
SK3201			
SK3202			
SK4201	250m (820ft)	125m (410ft)	
SK4202			
SK4203			

Table 8-3 Maximum motor cable lengths (400V drives)

400V Nominal AC supply voltage			
Model	Maximum permissible motor cable length for each of the following frequencies		
	3kHz	6kHz	12kHz
SK2401	200m (660ft)	100m (330ft)	50m (165ft)
SK2402			
SK2403			
SK2404			
SK3401			
SK3402			
SK3403	250m (820ft)	125m (410ft)	
SK4401			
SK4402			
SK4403			
SK5401			
SK5402			
SK6401			
SK6402			

Table 8-4 Maximum motor cable lengths (575V drives)

575V Nominal AC supply voltage			
Model	Maximum permissible motor cable length for each of the following frequencies		
	3kHz	6kHz	12kHz
SK3501	200m (660ft)	100m (330ft)	
SK3502			
SK3503			
SK3504			
SK3505			
SK3506			
SK3507			

Table 8-5 Maximum motor cable lengths (690V drives)

690V Nominal AC supply voltage			
Model	Maximum permissible motor cable length for each of the following frequencies		
	3kHz	6kHz	12kHz
SK4601	250m (820ft)	125m (410ft)	
SK4602			
SK4603			
SK4604			
SK4605			
SK4606			
SK5601			
SK5602			
SK6601			
SK6602			

- Cable lengths in excess of the specified values may be used only when special techniques are adopted; refer to the supplier of the drive.
- The default switching frequency is 3kHz.

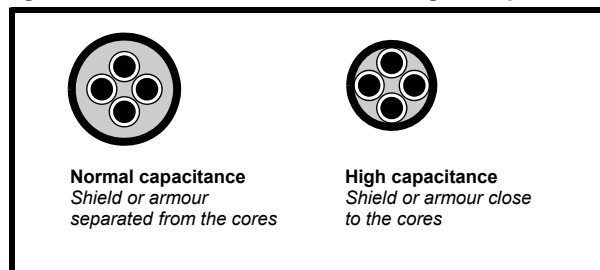
#### High-capacitance cables

The maximum cable length is reduced from that shown in Table 8-1, Table 8-2, Table 8-3 and Table 8-4 if high capacitance motor cables are used.

Most cables have an insulating jacket between the cores and the armor or shield; these cables have a low capacitance and are recommended.

Cables that do not have an insulating jacket tend to have high capacitance; if a cable of this type is used, the maximum cable length is half that quoted in the tables. (Figure 8-1 shows how to identify the two types.)


Figure 8-1 Cable construction influencing the capacitance



#### 8.2.1 Main AC supply contactor

The recommended AC supply contactor type for size A to D and 2 to 6 is AC1.

## 8.2.2 Output contactor



If the cable between the drive and the motor is to be interrupted by a contactor or circuit breaker, ensure that the drive is disabled before the contactor or circuit breaker is opened or closed. Severe arcing may occur if this circuit is interrupted with the motor running at high current and low speed.

A contactor is sometimes required to be installed between the drive and motor for safety purposes.

The recommended motor contactor is the AC3 type.

Switching of an output contactor should only occur when the output of the drive is disabled.

Opening or closing of the contactor with the drive enabled will lead to:

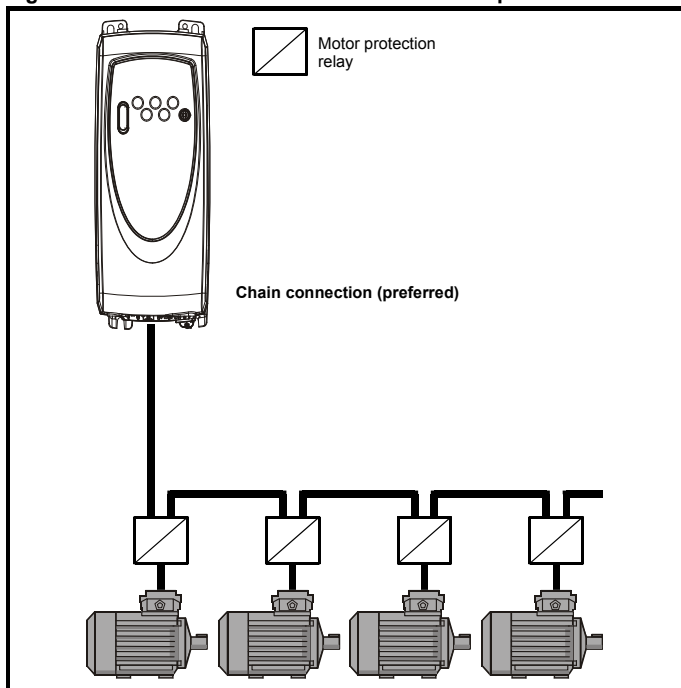
1. OI.AC trips (which cannot be reset for 10 seconds)
2. High levels of radio frequency noise emission
3. Increased contactor wear and tear

## 8.2.3 Multiple motors

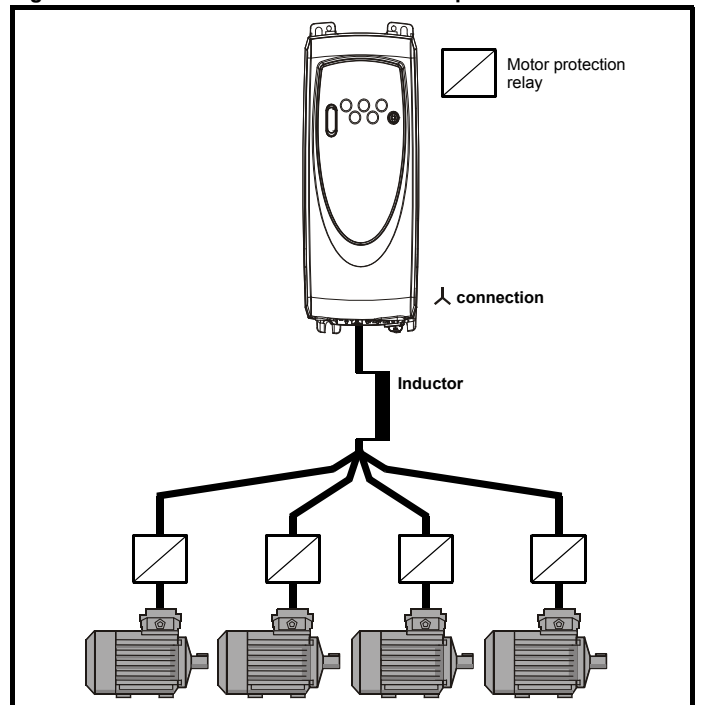
If the drive is to control more than one motor, one of the fixed V/F modes should be selected (Pr 5.14 = Fd or SrE). Make the motor connections as shown in Figure 8-2 and Figure 8-3. The maximum cable lengths in Table 8-1, Table 8-2, Table 8-3, Table 8-4 and Table 8-5 apply to the sum of the total cable lengths from the drive to each motor.

It is recommended that each motor is connected through a protection relay since the drive cannot protect each motor individually. For  $\Delta$  connection, a sinusoidal filter or an output inductor must be connected as shown in Figure 8-3, even when the cable lengths are less than the maximum permissible. For details of inductor sizes refer to the supplier of the drive.

**Figure 8-2 Preferred chain connection for multiple motors**



**Figure 8-3 Alternative connection for multiple motors**





## 9 General data

### 9.1 Ratings

#### 9.1.1 IP rating

##### All sizes

##### IP20

- The drive complies with the requirements of IP20 as standard.

##### Size A to C

##### IP4X

- The top surface of the drive complies with the requirements of IP4X when the drive is mounted vertically with the optional top cover installed.

##### Size 2 to 6

##### IP54

- The drive can achieve IP54 rating (NEMA 12) at the rear of the heatsink for through-panel mounting (some current derating is required).

**First digit:** Protection against contact and ingress of foreign bodies.

**2** - Protection against medium size foreign bodies  $\varnothing > 12\text{mm}$  (e.g. finger)

**4** - Protected against solid objects over 1mm (e.g. tools, wires and small wires)

**5** - Protection against dust deposit, complete protection against accidental contact

**Second digit:** Protection against ingress of water.

**0** - No protection

**4** - Protection against splash water (from all directions)

**X** - Not tested

### 9.2 Input phase imbalance

3% between phases or 2% negative phase sequence.

### 9.3 Ambient temperature

#### Size A to D:

-10°C (14°F) to 40°C (104°F) at 3kHz

Operation up to 55°C (131°F) with de-rating.

(see de-rating curves for further information)

#### Size 2 to 6:

Ambient temperature operating range:

0°C to 50°C (32°F to 122°F).

Output current derating must be applied at ambient temperatures >40°C (104°F).

Minimum temperature at power-up:

-15°C (5°F).

Cooling method: Forced convection

#### NOTE

The drive can be powered up and run at a minimum temperature of -10°C (14°F).

### 9.4 Storage

#### Storage temperature

##### Size A to D:

-40 to +60°C (-40 to +140°F) for 12 months max

##### Size 2 to 6:

-40 (-40°F) to +50°C (122°F) for long term storage, or to +70°C (158°F) for short term storage.

### Storage time

Storage time is 2 years.

Electrolytic capacitors in any electronic product have a storage period after which they require reforming or replacing.

The DC bus capacitors have a storage period of 10 years.

The low voltage capacitors on the control supplies typically have a storage period of 2 years and are thus the limiting factor.

Low voltage capacitors cannot be reformed due to their location in the circuit and thus may require replacing if the drive is stored for a period of 2 years or greater without power being applied.

It is therefore recommended that drives are powered up for a minimum of 1 hour after every 2 years of storage.

This process allows the drive to be stored for a further 2 years.

### 9.5 Altitude

#### Size A to D:

Rated altitude: 1000m (3250 ft)

Reduce the normal full load current by 1% for every 100m (325 ft) above 1000m (3250 ft) up to a maximum of 3000m (9750 ft).

#### Size 2 to 6:

Altitude range: 0 to 3,000m (9,900 ft), subject to the following conditions:

1,000m to 3,000m (3,300 ft to 9,900 ft) above sea level: de-rate the maximum output current from the specified figure by 1% per 100m (330 ft) above 1,000m (3,300 ft)

For example at 3,000m (9,900ft) the output current of the drive would have to be de-rated by 20%.

### 9.6 Environmental protection rating

The Commander SK is rated to IP20 pollution degree 2 (dry, non-conductive contamination only) (UL Type 1 / NEMA 1). However, it is possible to configure the drive to achieve IP54 rating (NEMA 12) at the rear of the heatsink for through-panel mounting (some current derating is required for size 2).

In order to achieve the high IP rating at the rear of the heatsink with Commander SK size 2, it is necessary to seal a heatsink vent by fitting the IP54 insert as shown in Figure 5-27 on page 62. For increased fan life time in a dirty environment the heatsink fan must be replaced with an IP54 rated fan on size 2 to 4. Sizes 5 and 6 are installed with IP54 heatsink fans as standard. Contact the supplier of the drive for details. Fitting of the IP54 insert and/or IP54 rated fan on size 2 requires output current derating to be applied, see section 2.5 Size 2 on page 31 for further details.

### 9.7 Humidity

Maximum relative humidity 95% non-condensing at 40°C (104°F).

### 9.8 Storage humidity

Maximum relative humidity 93%, 40°C, 4 days.

### 9.9 Pollution degree

Designed for operation in Pollution degree 2 environments (dry, non-conductive contamination only)

### 9.10 Materials

Flammability rating of main enclosure: UL94 - 5VA

### 9.11 Corrosive gases

Concentrations of corrosive gases must not exceed the levels given in:

- Table A2 of EN 50178:1998
- Class 3C2 of IEC 60721-3-3

This corresponds to the levels typical of urban areas with industrial activities and/or heavy traffic, but not in the immediate neighborhood of industrial sources with chemical emissions.

## 9.12 Vibration

### 9.12.1 Random

Standard: In accordance with IEC60068-2-64 and IEC60068-2-36:  
Test Fh

Severity: 1.0 m<sup>2</sup>/s<sup>3</sup> (0.01g<sup>2</sup>/Hz) ASD from 5 to 20Hz, -3dB/octave from 20 to 200Hz

Duration: 30 minutes in each of 3 mutually perpendicular axes.

### 9.12.2 Sinusoidal

Standard: IEC 60068-2-6: Test Fc

Frequency range: 2 to 500Hz

Severity: 3.5mm peak displacement from 2 to 9Hz  
10m/s<sup>2</sup> peak displacement from 9 to 200Hz  
15m/s<sup>2</sup> peak displacement from 200 to 500Hz

Sweep rate: 1 octave/minute

Duration: 15 minutes in each of 3 mutually perpendicular axes.

### 9.12.3 Bump

Standard: IEC60068-2-29: Test Eb

Severity: 18g, 6ms, half sine

Number of bumps: 600 (100 in each direction of axes)

## 9.13 Frequency accuracy

0.01%

## 9.14 Resolution

0.1Hz

## 9.15 Output frequency range

0 to 1500Hz

## 9.16 Starts per hour

### Electric starts

With the supply permanently connected the number of electronic motor starts per hour is only limited by motor and drive thermal limits.

### Power starts

The number of starts by connection of the ac supply is limited. The start up circuit will allow for three consecutive starts at 3-second intervals on initial power up. Exceeding the rated number of starts per hour, presented in the table below, could result in damage to the start up circuit.

Drive frame size	Maximum AC line starts per hour evenly spaced in time
A, B, C, D and 2 to 6	20

## 9.17 Start-up time

The soft-start circuit must charge the DC bus and SMPS outputs and stabilise to allow the control processor to start operation in the following times:-

Drive frame size	Voltage	Maximum time taken to charge DC bus and SMPS outputs to stabilise
A	110 and 200	1s
B	110	1.5s
B and C	200	2s
B and C	400	1s
D	All	1s
2 to 6	All	4s

## 9.18 Serial communications

Modbus RTU

## 9.19 Switching frequencies

The software allows for the following switching frequencies:

Drive size	Voltage rating	3kHz	6kHz	12kHz	18kHz
A, B & C	200	√	√	√	√
B & C	400	√	√	√	
D	All	√	√	√	
2	All	√	√	√	
3	SK320X	√	√	√	
	SK3401 & SK3402	√	√	√	
	SK3403	√	√	√	
	SK350X	√	√		
4	All	√	√		
5	All	√	√		
6	All	√	√		

### NOTE

With drive firmware V01.07.01 onwards, the size C 400V drive will have an actual switching frequency of 3kHz when the output frequency is below 6Hz.

## 9.20 Harmonics

The Commander SK industrial AC variable speed drives are classified as class A professional equipment as defined in BS EN 61000-3-2:2006. Drives with input power equal to or below 1kW that do not meet the requirements of EN 61000-3-2:2006 are to be corrected, to ensure compliance, at the point of installation using suitable AC line chokes. See 7.2 (Reactor current ratings)

## 9.21 Acoustic noise

Frame	Power ratings	Condition	Max SPL measurement (dBA)
A	All ratings	N/A	None contributed by drive (no fan)
B	≤0.75kW	N/A	None contributed by drive (no fan)
B	≥1.1kW	rd mode, fan on	50
C	All ratings	rd mode, fan on	53

Size	Max speed dBA	Min speed dBA
D & 2	54	35
3	56	43
4	53	
5	72	
6	72	

## 10 I/O specification



**WARNING**

The control circuits are isolated from the power circuits in the drive by basic insulation (single insulation) only. The installer must ensure that the external control circuits are insulated from human contact by at least one layer of insulation (supplementary insulation) rated for use at the AC supply voltage.



**WARNING**

If the control circuits are to be connected to other circuits classified as Safety Extra Low Voltage (SELV) (e.g. to personal computer), an additional isolating barrier must be included in order to maintain the SELV classification.

<b>T1</b>	<b>0V common</b>
-----------	------------------

<b>T2</b>	<b>Analog input 1 (A1), either voltage or current</b>
Voltage: Current input	0 to 10V: mA as parameter range
Parameter range	4-20, 20-4, 0-20, 20-0, 4-.20, 20-.4, Volt
Scaling	Input range automatically scaled to Pr 01 ( <i>Minimum set speed</i> ) to Pr 02 ( <i>Maximum set speed</i> )
Input impedance	200Ω (current): 100kΩ (voltage)
Resolution	0.1%
Accuracy	± 2%
Sample time	6ms
Absolute maximum voltage range	+35V to -18V with respect to 0V common

<b>T3</b>	<b>+10V reference output</b>
Maximum output current	5mA
Protection	Tolerates continuous short circuit to 0V
Accuracy	± 2%

<b>T4</b>	<b>Analog input 2 (A2), either voltage or digital input</b>
Voltage: Digital input	0 to +10V: 0 to +24V
Scaling (as voltage input)	Input range automatically scaled to Pr 01 <i>Minimum set speed</i> / Pr 02 <i>Maximum set speed</i>
Input impedance	100kΩ (voltage): 6k8 (digital input)
Resolution	0.1%
Accuracy	± 2%
Sample time	6ms
Nominal threshold voltage	+10V (positive logic only)
Absolute maximum voltage range	+35V to -18V with respect to 0V common

<b>T5</b> <b>T6</b>	<b>Status relay - Drive ok (Normally open)</b>
Contact voltage rating	240Vac 30Vdc
Contact maximum current rating	2Aac 240V 4Adc 30V resistive load (2A 35Vdc for UL requirements) 0.3Adc 30V inductive load (L/R = 40ms)
Contact minimum recommended rating	12V 100mA
Contact isolation	1.5kVac (over voltage category II)
Update time	1.5ms
Operation of contact	OPEN - AC supply removed from drive. - AC supply applied to drive with drive in tripped condition. CLOSED - AC supply applied to drive with drive in a 'ready to run' or 'running' condition (not tripped)



Provide fuse or other over-current protection in status relay circuit.

**WARNING**



A flyback diode should be installed across inductive loads connected to the status relay.

**WARNING**

<b>B1</b>	<b>Analog voltage output - Motor speed</b>	
Voltage output	0 to +10V	
Scaling	0V represents 0Hz/rpm output +10V represents the value in Pr <b>02</b> , maximum set speed	
Maximum output current	5mA	
Resolution	0.1%	
Accuracy	± 5%	
Update time	6ms	
Protection	Tolerates continuous short circuit to 0V	

<b>B2</b>	<b>+24V output</b>	
Maximum output current	100mA	
Protection	Tolerates continuous short circuit to 0V	
Accuracy	± 15%	

<b>B3</b>	<b>Digital output - Zero speed (or digital input)</b>	
Voltage range	0 to +24V	
Maximum output current	50mA at +24V (current source)	
Output impedance	6.8kΩ	
Update time	1.5ms	
Absolute maximum voltage range	+35V to -1V with respect to 0V common	

**NOTE**

The total available current from the digital output plus the +24V output is 100mA. Terminal B3 can also be configured as a digital input, frequency output or PWM output. Refer to the *Commander SK Advanced User Guide* for more information.

<b>B4</b>	<b>Digital Input - Enable/Reset */**</b>	
<b>B5</b>	<b>Digital Input - Run Forward **</b>	
<b>B6</b>	<b>Digital Input - Run Reverse **</b>	
<b>B7</b>	<b>Digital Input - Local/Remote speed reference select (A1/A2)</b>	
Logic	Positive logic only	
Voltage range	0 to +24V	
Input impedance	6.8kΩ	
Sample time	1.5ms	
Nominal threshold voltage	+10V	
Absolute maximum voltage range	+35V to -18V with respect to 0V common	

Terminal B7 can also be configured as a thermistor input or frequency input. Refer to the *Commander SK Advanced User Guide* for more information.

**NOTE**

If the drives enable terminal is opened, the drives output is disabled and the motor will coast to a stop. The drive will not re-enable for 1s after the enable terminal is closed again.

## 10.1 Drive reset

\*Following a drive trip, opening and closing the enable terminal will reset the drive. If the run forward or run reverse terminal is closed, the drive will run straight away.

\*\*Following a drive trip and a reset via the stop/reset key, the enable, run forward or run reverse terminals will need to be opened and closed to allow the drive to run. This ensures that the drive does not run when the stop/reset key is pressed.

The enable, run forward and run reverse terminals are level triggered apart from after a trip where they become edge triggered. See \* and \*\* above.

If the enable and run forward or enable and run reverse terminals are closed when the drive is powered up, the drive will run straight away up to a set speed.

If both the run forward and run reverse terminals are closed, the drive will stop under the control of the ramp and stopping modes set in Pr 30 and Pr 31.

depends on the destination/source parameter of the digital or analog inputs/outputs.

These sample/update times are the sample or update times for the control microprocessor. The actual sample/update time maybe slightly longer due to the design of the Commander SK.

## 10.3 Task routine times

At the beginning of each menu, there is a single line parameter description and this contains the update rate for each parameter. This time signifies the task routine time in the software that the parameter is updated on. For a background task, the time depends on processor loading i.e. what functions the drive is carrying out and what advanced menus are being used.

## 10.2 Sample/update times

The sample/update times shown in the control terminal specification within the *Commander SK Technical Guide* are the default sample/update times for the default terminal set-up. The sample/update time

Update rate	Microprocessor update time	Comments
2ms	2ms	Updated every 2ms
5ms	5ms	Updated every 5ms
21ms	21ms	Updated every 21ms
128ms	128ms	Updated every 128ms
Reset	N/A	Destination/source parameter changed on a Reset
B	Background	Updated as a background task. Update rate depends on processor loading.
BR	Background read	
BW	Background write	


From practical tests carried out:

Condition	Minimum ms	Maximum ms	Average ms
Time for drive to respond to a run command	4.1	5.62	5.02
Time for the drive to respond to a stop command	2.82	3.94	3.31
Time for the drive to respond to a step change in analog input voltage			7.93

# 11 Supply types

All drives are suitable for use on any supply type i.e. TN-S, TN-C-S, TT and IT.

- Supplies with voltage up to 600V may have grounding at any potential, i.e. neutral, centre or corner ("grounded delta")
  - Supplies with voltage above 600V may not have corner grounding
- Drives are suitable for use on supplies of installation category III and lower, according to IEC60664-1. This means they may be connected permanently to the supply at its origin in a building, but for outdoor installation additional over-voltage suppression (transient voltage surge suppression) must be provided to reduce category IV to category III.



**WARNING**

Operation with IT (ungrounded) supplies: Special attention is required when using internal or external EMC filters with ungrounded supplies, because in the event of a ground (earth) fault in the motor circuit, the drive may not trip and the filter could be over-stressed. In this case, either the filter must not be used (removed) or additional independent motor ground fault protection must be provided. Refer to Table 11-1. For instructions on removal, refer to section 6.2 *Internal EMC filter* on page 79. For details of ground fault protection contact the supplier of the drive.

A ground fault in the supply has no effect in any case. If the motor must continue to run with a ground fault in its own circuit, then an input-isolating transformer must be provided and if an EMC filter is required it must be located in the primary circuit.

Unusual hazards can occur on ungrounded supplies with more than one source, for example on ships. Contact the supplier of the drive for more information.

**Table 11-1 Behavior of the drive in the event of a motor circuit ground (earth) fault with an IT supply**

Drive size	Internal filter only	External filter (with internal)
2	Drive trips on fault	Drive trips on fault
3	May not trip – precautions required	Drive trips on fault
4 to 6	May not trip – precautions required	May not trip – precautions required

## 11.1 AC supply requirements

### Single phase drives

Single phase - Between one phase and neutral of a star connected three phase supply.

- Between two phases of a three phase supply.

### Three phase models


Three-phase star or delta supply of the correct voltage.

### Dual rated models

Any of the above supplies can be used.

Maximum supply imbalance: 2% negative phase sequence (equivalent to 3% voltage imbalance between phases).

## 11.2 Safety




**WARNING**

**Electric shock risk**  
The voltages present in the following locations can cause severe electric shock and may be lethal:


- AC supply cables and connections
- DC and brake cables and connections
- Output cables and connections
- Many internal parts of the drive, and external option units

Unless otherwise indicated, control terminals are single insulated and must not be touched.




**WARNING**

**Isolation device**  
The AC supply must be disconnected from the drive using an approved isolation device before any cover is removed from the drive or before any servicing work is performed.




**WARNING**

**STOP function**  
The STOP function does not remove dangerous voltages from the drive, the motor or any external option units.



**WARNING**

**Stored charge**  
The drive contains capacitors that remain charged to a potentially lethal voltage after the AC supply has been disconnected. If the drive has been energized, the AC supply must be isolated at least ten minutes before work may continue. Normally, the capacitors are discharged by an internal resistor. Under certain, unusual fault conditions, it is possible that the capacitors may fail to discharge, or be prevented from being discharged by a voltage applied to the output terminals. If the drive has failed in a manner that causes the display to go blank immediately, it is possible the capacitors will not be discharged. In this case, consult Control Techniques or their authorized distributor.



**WARNING**

**Equipment supplied by plug and socket**  
Special attention must be given if the drive is installed in equipment which is connected to the AC supply by a plug and socket. The AC supply terminals of the drive are connected to the internal capacitors through rectifier diodes which are not intended to give safety isolation. If the plug terminals can be touched when the plug is disconnected from the socket, a means of automatically isolating the plug from the drive must be used (e.g. a latching relay).

## 11.3 Cables

Recommended cable sizes are given in Chapter 1 *Technical data* on page 5. They are only a guide; refer to local wiring regulations for correct size of cables. In some cases, a larger cable size is required to avoid excessive voltage drop.

Use 105°C (221°F) (UL 60/75°C temp rise) PVC-insulated cable with copper conductors having a suitable voltage rating, for the following power connectors:

- AC supply to external EMC filter (when used)
- AC supply (or external EMC filter) to drive
- Drive to motor
- Drive to braking resistor

### Motor cables

The recommended output cable sizes assume that the motor maximum current matches that of the drive. Where a motor of reduced rating is used, the cable rating may be chosen to match that of the motor. To ensure that the motor and cable are protected against overload, the drive must be programmed with the correct motor rated current.

## 11.4 Fuses

The AC supply to the drive must be installed with suitable protection against overload and short circuits. Chapter 1 *Technical data* on page 5 shows the recommended fuse ratings. Failure to observe this requirement will cause risk of fire.

A fuse or other protection device must be included in all live connectors to the AC supply.

An MCB (miniature circuit breaker) or MCCB (moulded case circuit breaker) with type C tripping characteristics maybe used in place of fuses as long as the fault clearing capacity is sufficient for the installation. On Commander SK sizes 2 and 3 an MCB/MCCB of type C may be used in place of fuses under the following conditions:

- The fault-clearing capacity must be sufficient for the installation.
- The drive must be mounted in an enclosure which meets the requirements for a fire enclosure.

#### NOTE

If a MCB is used it will not meet UL listing requirements.

### Fuse types

Europe: Type gG HRC fuses complying with EN60269 parts 1 and 2 (BS88)

USA: Bussman Limitron KTK series, class CC or class J fast acting fuses up to 30A, class J above 30A.

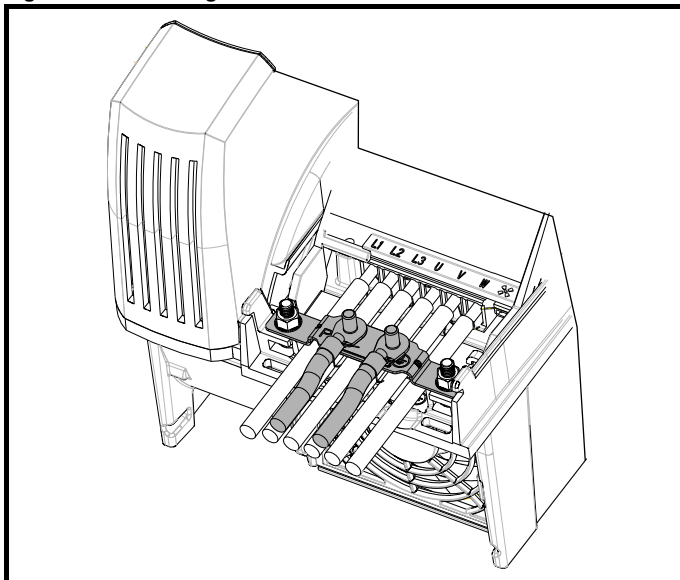
## 11.5 Ground connections

The drive must be connected to the system ground of the AC supply. The ground wiring must conform to local regulations and codes of practice.

The ground loop impedance must conform to the requirements of local safety regulations. The ground connections must be inspected and tested at appropriate intervals.

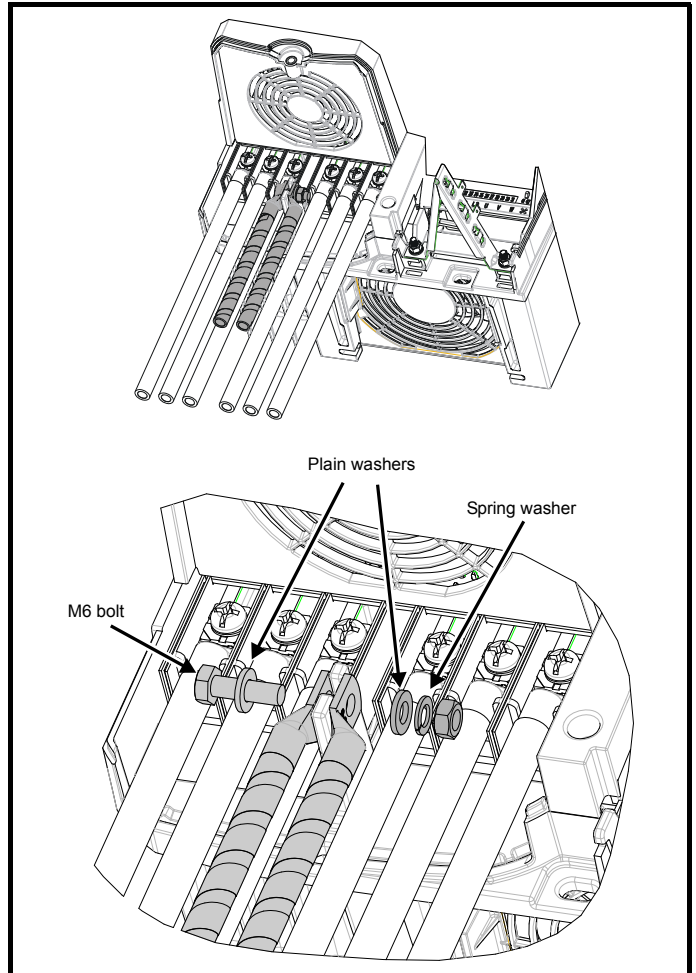
On Commander SK size 2, the supply and motor ground connections are made using the grounding bridge that locates at the bottom of the drive.

Figure 11-1 Size 2 ground connections



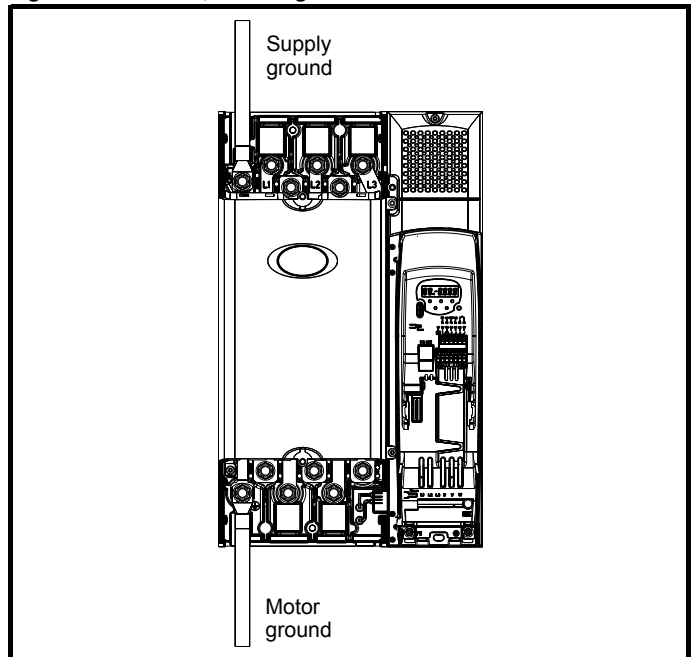
On Commander SK size 3, the supply and motor ground connections are made using an M6 nut and bolt that locates in the fork protruding from the heatsink between the AC supply and motor output terminals.

Figure 11-2 Size 3 ground connections



On Commander SK size 4, 5 and 6, the supply and motor ground connections are made using an M10 bolt at the top (supply) and bottom (motor) of the drive.

Figure 11-3 Size 4, 5 and 6 ground connections



The supply and motor ground connections to the drive are connected internally by a copper conductor with a cross-sectional area given below:

size 4: 19.2mm<sup>2</sup> (0.03in<sup>2</sup>, or slightly bigger than 6 AWG)

size 5: 60mm<sup>2</sup> (0.09in<sup>2</sup>, or slightly bigger than 1 AWG)

size 6: 75mm<sup>2</sup> (0.12in<sup>2</sup>, or slightly bigger than 2/0 AWG)

This connection is sufficient to provide the ground (equipotential bonding) connection for the motor circuit under the following conditions:

To standard	Conditions
IEC 60204-1 & EN 60204-1	Supply phase conductors having cross-sectional area not exceeding: size 4: 38.4mm <sup>2</sup> size 5: 120mm <sup>2</sup> size 6: 150mm <sup>2</sup>
NFPA 79	Supply protection device rating not exceeding: size 4: 200A size 5: 600A size 6: 1000A

If the necessary conditions are not met, an additional ground connection must be provided to link the motor circuit ground and the supply ground.

### Use of RCDs - residual current device

There are three common types of RCD/ELCB

**Type AC** - detects AC fault currents

**Type A** - detects AC and pulsating DC fault currents (provided the DC current reaches zero at least once every half cycle)

**Type B** - detects AC, pulsating DC, and smooth DC fault currents

- Type AC should never be used with inverter drives
- Type A can only be used with single phase drives
- Type B must be used with three phase drives.

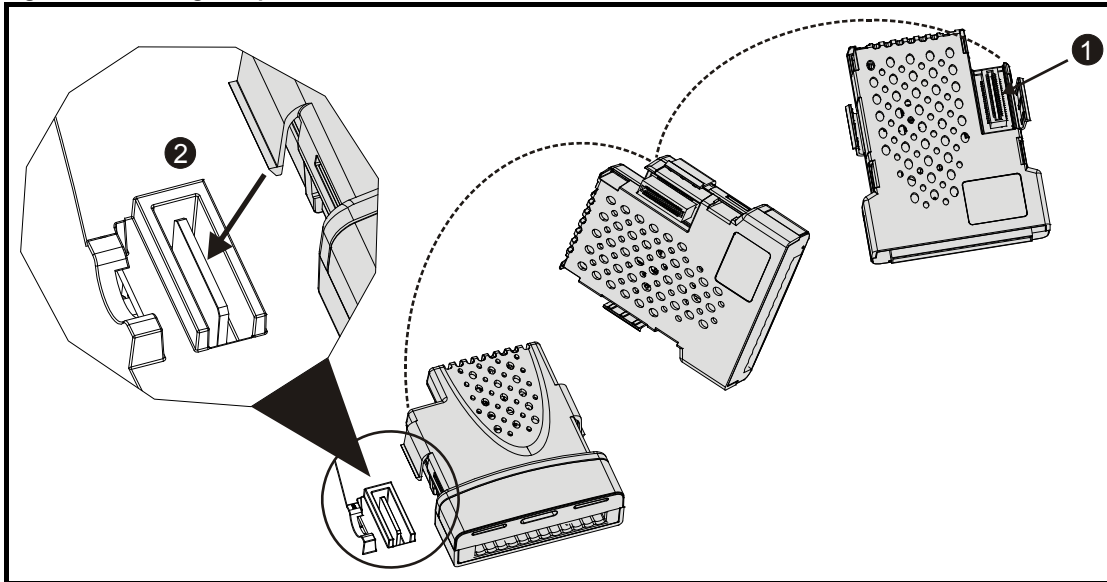
### It is recommended that only Type B RCDs be used with inverter drives

If an external EMC filter is used, a delay of at least 50ms should be incorporated in the RCD to ensure spurious trips are not seen. The leakage current is likely to exceed the trip level if all of the phases are not energized simultaneously.





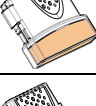
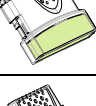










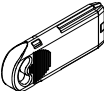

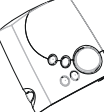

## 12 Options


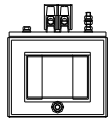







Figure 12-1 Fitting an Option Module



All Commander SK Solutions Modules are color-coded, in order to make identification easy. The following table shows the color-code key and gives further details on their function.

Type	Option	Color	Name	Further details	Minimum option firmware version	Unidrive SP compatible ?
Fieldbus*		Purple	SM-PROFIBUS-DP-V1	<b>PROFIBUS-DP-V1 option</b> PROFIBUS-DP-V1 adapter for communication with Commander SK	03.00.00	Yes
		Medium Grey	SM-DeviceNet	<b>DeviceNet option</b> DeviceNet adapter for communication with Commander SK	03.00.00	Yes
		Dark Grey	SM-INTERBUS	<b>INTERBUS option</b> INTERBUS adapter for communication with Commander SK	03.00.00	Yes
		Light Grey	SM-CANopen	<b>CANopen option</b> CANopen adapter for communication with Commander SK	03.00.00	Yes
		Beige	SM-Ethernet	<b>Ethernet option</b> Ethernet adapter for communication with Commander SK	01.00.00	Yes
		Pale green	SM-LON	<b>LonWorks option</b> LonWorks adapter for communications with Commander SK	01.00.00	Yes
		Brown Red	SM-EtherCAT	<b>EtherCAT option</b> EtherCAT adapter for communications with Commander SK	01.00.00	Yes

Type	Option	Color	Name	Further details	Minimum option firmware version	Unidrive SP compatible ?
Extended IO*		Dark Yellow	SM-I/O Lite	<b>I/O Lite option</b> Increases the I/O capability by adding the following to the existing I/O in the drive: <ul style="list-style-type: none"> <li>±10V bi-polar / 4-20mA analog input</li> <li>0-10V / 4-20mA analog output</li> <li>Digital inputs x 3</li> <li>Encoder speed reference input (A, /A, B, / B)</li> <li>Relay x 1</li> </ul>	01.01.07	Yes
		Dark Red	SM-I/O Timer	<b>Timer I/O option</b> Same features as SM-I/O Lite, but with the addition of a battery backed-up real time clock.	01.01.07	Yes
		Olive	SM-I/O 120V	<b>Additional I/O conforming to IEC 1131-2 120Vac</b> 6 digital inputs and 2 relay outputs rated for 120Vac operation	01.00.01	Yes
		Turquoise	SM-I/O PELV	<b>Isolated I/O to NAMUR NE37 specifications</b> For chemical industry applications 1 x Analog input (current modes) 2 x Analog outputs (current modes) 4 x Digital input / outputs, 1 x Digital input, 2 x Relay outputs	03.01.03	Yes
		Cobalt Blue	SM-I/O 24V Protected	<b>Additional I/O with overvoltage protection up to 48V</b> 2 x Analog outputs (current modes) 4 x Digital input / outputs, 3 x Digital inputs, 1 x Relay output	03.01.03	Yes
		Yellow	SM-I/O 32	<b>Additional I/O with thirty two Digital input lines</b> 32 x Digital input / outputs.	01.00.00	Yes
Automation		Black	SmartStick	<b>SmartStick option</b> Upload drive parameters to the SmartStick for storage or for easy set-up of identical drives or downloading to replacement drives		No
		White	LogicStick	<b>LogicStick option</b> The LogicStick plugs into the front of the drive and enables the user to program PLC functions within the drive. (The LogicStick can also be used as a SmartStick) (The LogicStick guard is now supplied with the LogicStick)		No
		Black	LogicStick Guard Kitbag	The LogicStick guard protects the Logicstick when installed to a drive (set of 25)		No
Keypad			SM-Keypad Plus	<b>LCD keypad display option</b> Remote panel mounting LCD multilingual text keypad display to IP54 (NEMA 12) with additional help key	04.03.01	Yes
			SK-Keypad Remote	<b>LED keypad display option</b> Remote panel mounting LED display to IP65 (NEMA 12) with additional function key	01.00.00	No

Type	Option	Color	Name	Further details	Minimum option firmware version	Unidrive SP compatible ?
EMC			EMC Filters	These additional filters are designed to operate together with the drive's own integral EMC filter in areas of sensitive equipment		No
			AC input line reactors	To reduce supply harmonics		No
Cable management**			SK-Bracket	Cable management bracket		No
			UL type 1 kit	Bottom metal gland plate, top cover and side covers to allow the drive to comply with the requirements of UL type 1 / NEMA 1		No
SK Cover kit**			Cover kit	The additional cover kit will increase the environmental protection of the top face to IP4X in vertical direction.		No
Communications			CT Comms cable	Cable with isolation RS232 to RS485 converter. For connecting PC/Laptop to the drive when using CTSOft or SyPTLite		Yes
			CT USB Comms cable	Cable with isolation RS232 to RS485 converter. For connecting PC/Laptop to the drive when using CTSOft or SyPTLite		Yes
			CTSOft	Software for PC or Laptop which allows the user to commission and store parameter settings	01.04.01	Yes
			SyPTLite	Software for PC or Laptop which allows the user to program PLC functions within the drive	01.02.02	Yes
Braking resistor			Braking resistor	Optional internal braking resistor for Commander SK size 2		Yes

\*Not compatible with size A

\*\* Not available for size 2 to 6.

# Index

- A**  
AC input line reactors ..... 119  
Accuracy ..... 111, 112  
Air flow ..... 6, 7, 8, 14, 15, 17, 76
- B**  
Braking resistor 5, 6, 7, 11, 14, 15, 17, 68, 69, 70, 71, 99, 119  
Brown-out ..... 43
- C**  
Cable clamp ..... 100  
Cable clearances ..... 103  
Cables ..... 5, 6, 7, 10, 11, 13, 15, 17, 70  
Calculating ..... 76  
Conduit Boxes ..... 57, 66  
Contactor ..... 108  
Control ..... 5, 6, 7, 13, 53  
Cooling fan ..... 6, 7, 8, 11, 14, 15, 17  
Current ..... 5, 6, 7, 10, 12, 14, 31, 33, 35, 37, 38, 39  
Current limit ..... 12
- D**  
DC bus ..... 5, 6, 7, 12, 14, 16, 40, 41, 42, 43, 70  
DIN rail ..... 5, 6, 7, 44, 45, 46, 47
- E**  
Earth leakage circuit breakers residual current device ..... 101  
EMC ..... 119  
EMC - Compliance with generic emission standards ..... 98  
EMC - General requirements ..... 102  
EMC - Variations in the wiring ..... 99  
EMC filter ..... 5, 6, 7  
Emission ..... 80  
Enclosure ..... 75
- F**  
Fan ..... 56, 61, 73  
Ferrite ring ..... 90, 100  
Fire enclosure ..... 115  
Frequency ..... 5, 6, 7, 10, 12, 14, 16  
Fuses ..... 5, 6, 11, 12, 13, 14, 15, 16, 17
- G**  
Grommets ..... 70  
Ground connections ..... 102  
Grounding ..... 99  
Grounding bracket ..... 54, 55, 100  
Grounding bridge ..... 115  
Grounding clamp ..... 100  
Grounding link bracket ..... 101
- I**  
Inductance ..... 10, 42, 43  
Induction motors ..... 9  
Input impedance ..... 112  
Inrush ..... 5, 6, 7, 10, 12, 14, 42  
IP54 ..... 56, 61, 68, 109  
Isolator switch ..... 100
- L**  
Lifting bracket ..... 60  
LogicStick ..... 118
- M**  
MCB ..... 115  
MCCB ..... 115  
Motor cable - interruptions ..... 100  
Motor isolator-switch ..... 100  
Mounting ..... 44, 45, 46, 47, 49, 50, 51, 52, 53, 54, 55, 56, 60  
Mounting bracket ..... 60, 70
- N**  
NEMA 12 ..... 56, 61, 68, 109  
NEMA rating ..... 61, 109
- O**  
Output contactor ..... 108  
Overload ..... 5, 6, 7, 9, 10, 12, 70
- P**  
Power ..... 5, 6, 7, 10, 12, 14
- R**  
Ramp ..... 40  
Ratings ..... 5, 6, 7, 10, 12, 14, 16  
RCD ..... 116  
Resolution ..... 111, 112  
Routine maintenance ..... 73
- S**  
Sample time ..... 111  
Scaling ..... 111, 112  
Sealed enclosure - sizing ..... 75  
Shielding ..... 99  
Shock ..... 44, 45  
SK-Bracket ..... 119  
SK-Keypad Remote ..... 118  
SmartStick ..... 118  
SM-Keypad Plus ..... 118  
Spacing ..... 49  
Supply ..... 5, 6, 7, 10, 12, 14, 16  
Supply imbalance ..... 114  
Surge suppression ..... 97  
Surge suppression for analog and bipolar inputs and outputs 97  
Surge suppression for digital and unipolar inputs and outputs 97  
Switching frequency ..... 12, 18, 22, 90, 107
- T**  
Terminal block in the enclosure ..... 100  
Thermal overload relay ..... 72  
Trip ..... 40
- U**  
UL ..... 39, 68, 119
- V**  
Vibration ..... 44, 45  
Voltage ..... 5, 6, 7  
Voltage range ..... 112
- W**  
Weight ..... 5, 6, 7, 10, 12, 14





**0472-0002-09**