

CL400 / CL500

MOBY I/F Channel Module Module Description



Edition

102



BOSCH
Automation

CL400 / CL500

MOBY I/F Channel Module Module Description

1070 072 136-102 (99.11) GB



© 1992–1999

by Robert Bosch GmbH, Erbach / Germany
All rights reserved, including applications for protective rights.
Reproduction or distribution by any means subject to our prior written permission.

Discretionary charge 10.00 DM

Contents

| | Page |
|----------|--|
| 1 | Safety Instructions 1–1 |
| 1.1 | Standard operation 1–1 |
| 1.2 | Qualified personnel 1–2 |
| 1.3 | Safety markings on components 1–3 |
| 1.4 | Safety instructions in this manual 1–4 |
| 1.5 | Safety instructions concerning the described product 1–5 |
| 1.6 | Documentation, version and trademark 1–7 |
| 2 | MOBY I/F Channel Module Functions 2–1 |
| 3 | Operating the MOBY I/F Channel Module 3–1 |
| 3.1 | Construction, Indicators, Settings 3–1 |
| 3.2 | Installing the MOBY I/F 3–6 |
| 3.3 | X10 Connector for 24 V Power Supply 3–9 |
| 3.4 | STG 4F Service und Testing Unit 3–13 |
| 4 | Module Specifications 4–1 |
| A | Appendix A–1 |
| A.1 | Abbreviations A–1 |
| A.2 | Amendments A–2 |
| A.3 | Index A–3 |

1 Safety Instructions

Before you start working with the MOBY I/F Channel Module, we recommend that you thoroughly familiarize yourself with the contents of this instruction manual. Keep this manual in a place where it is always accessible to all users.

1.1 Standard operation

This instruction manual presents a comprehensive set of instructions and information required for the standard operation of the described products.

The products described hereunder

- were developed, manufactured, tested and documented in accordance with the relevant safety standards. In standard operation, and provided that the specifications and safety instructions relating to the project phase, installation and proper operation of the product are followed, there should arise no risk of danger to personnel or property.
- are certified to be in full compliance with the following standards:
 - EMC Directives (89/336/EEC, 93/68/EEC, and 93/44/EEC)
 - Low-voltage Directive (73/23/EEC)
 - Harmonized standards EN 50081-2 and EN 50082-2
- are designed for operation in an industrial environment (class A emissions), i.e.,

- not directly connected to the public low-voltage power supply,
- connected via a transformer to the medium to high-voltage network.

The following shall apply to the operation of the described products within a private residence, in business areas, on retail premises or in small-industry settings:

- Installation in a control cabinet and/or an enclosure providing a high screening factor.
- All cables exiting from the screened area must be protected by suitable filtering and screening measures.
- The user will be required to obtain a single operating license issued by the appropriate national authority or approval body. In Germany, this is the Federal Institute for Posts and Telecommunications and/or its local branch offices.

 **This is a Class A device. In a residential area, this device may cause radio interference. If this is the case, the user or operator may be required to provide appropriate remedial measures at his own expense.**

The prerequisites for trouble-free service and safe operation of the product are proper transport, handling and storage, placement and installation, plus careful operation of the equipment.

1.2 Qualified personnel

The requirements pertaining to qualified personnel are based on the job specifications as outlined by the ZVEI (central association of the electrical industry) and VDMA (association of German machine and plant builders) professional associations in Germany. Please refer to the following German-language publication:

Weiterbildung in der Automatisierungstechnik

Hrsg.: ZVEI und VDMA

MaschinenbauVerlag

Postfach 71 08 64

60498 Frankfurt

This instruction manual is specifically designed for PLC specialists. They will require specific knowledge of Programmable Logic Controllers and of the peripheral bus for the CL400/CL500 control units.

Interventions in the hardware and software of our products which are not described in this instruction manual may only be performed by specially trained Bosch personnel.

Unqualified interventions in the hardware or software or non-compliance with the warnings listed in this instruction manual or indicated on the product may result in serious personal injury or damage of property.

Installation and maintenance of the products described hereunder is the exclusive domain of trained electricians as per VDE 1000-10, who are familiar with the contents of this manual.

Trained electricians are persons of whom the following is true:

- They are capable, due to their professional training, skills and expertise, and based upon their knowledge of and familiarity with applicable technical standards, of assessing the work to be carried out, and of recognizing possible hazards.
- They possess, subsequent to several years' experience in a comparable field of endeavour, a level of knowledge and skills that may be deemed commensurate with that attainable in the course of a formal professional education in this area.

With regard to the foregoing, please read the information about our comprehensive training program. You'll find a listing of our seminars on the front inside cover of this instruction manual. The professional staff at our training centre will be pleased to provide detailed information. You may contact the centre by telephone at (+49) (0)6062 78-258.

1.3 Safety markings on components



Danger: High voltage!



Danger: Battery acid!



Electrostatically sensitive components!



Disconnect at mains before opening!



Pin for connecting PE conductor only!



Functional earthing/low noise earth



For screened conductor only!

1.4 Safety instructions in this manual



DANGEROUS ELECTRICAL VOLTAGE

This symbol is used to warn of the presence of a **dangerous electrical voltage**. Insufficient compliance with or failure to observe this warning may result in **personal injury**.



DANGER

This symbol is used wherever insufficient or lacking compliance with instructions may result in **personal injury**.



CAUTION

This symbol is used whenever insufficient or lacking compliance with instructions may result in **damage to equipment or data files**.

 This symbol is used to alert the user to an item of special interest.

1.5 Safety instructions concerning the described product

**DANGER**

Fatal injury hazard through ineffective Emergency-STOP safety devices!

Emergency-STOP devices must remain effective and accessible in all system operating modes. The release of functional locks imposed by Emergency-STOP devices must never be allowed to cause an uncontrolled system restart! Before restoring power to the system, test the Emergency-STOP circuit!

**DANGER**

Danger to Personnel and Equipment!

Test every new program prior to initial system startup!

**DANGER**

Retrofits or modifications may adversely affect the safety of the products described!

The consequences may be severe personal injury, damage to equipment or environmental hazards. Therefore, any system retrofitting or modification utilizing third-party components will require express approval by Bosch.

**DANGEROUS ELECTRICAL VOLTAGE**

Unless otherwise indicated, maintenance procedures must always be carried out with the system switched OFF! The system must be protected and secured against inadvertent restart.

In the event that measuring or testing procedures must be carried out while the system is active, these shall be performed by trained electricians.

**CAUTION**

Danger to the module!

Do not insert or remove the module while the controller is switched ON! This may destroy the module. Prior to inserting or removing the module, switch OFF or remove the power supply module of the controller, external power supply and signal voltage!

**CAUTION**

Only Bosch approved spare parts may be used!

**CAUTION****Danger to the module!****All ESD protection measures must be observed when using the module! Prevent electrostatic discharges!**

Observe the following protective measures for electrostatically sensitive devices (ESD)!

- The personnel responsible for storage, transport and handling must be trained in ESD protection.
- ESDs must be stored and transported in the dedicated protective packaging specified for this purpose.
- Out of principle, ESDs may only be handled at special ESD work stations equipped for this particular purpose.
- Personnel, work surfaces and all devices and tools that could come into contact with ESDs must be on the same potential (e.g. earthed).
- An approved earthing wrist strap shall be worn. It must be connected to the work surface via a cable with an integrated 1 MΩ resistor.
- ESDs may under no circumstances come into contact with objects susceptible to accumulating an electrostatic charge. Most items made of plastics belong to this category.
- When installing ESDs in or removing them from an electronic device, the power supply of the device must be switched OFF.

1.6 Documentation, version and trademark

Documentation

The present instruction manual provides information about installation and operation of the MOBY I/F channel modules. These instructions do not include industry-standard planning and installation procedures.

Overview of instruction manuals:

| Instruction manuals | Language | Part no. |
|---|----------|--------------|
| PBK Peripheral Bus Interface Module, Module Description | German | 1070 070 127 |
| | English | 1070 072 133 |
| | Spanish | 1070 072 330 |
| MOBY I/F Channel Module, Module Description | German | 1070 070 139 |
| | English | 1070 072 136 |
| | Spanish | 1070 072 331 |
| PBK5MIF Software Module, Software Module Description | German | 1070 072 035 |
| | English | 1070 072 135 |
| | Spanish | 1070 072 332 |

- ★ This asterisk symbol indicates that the instruction manual is describing an activity you shall be required to perform.

Amendments

Changes in this instruction manual from the previous manual version are denoted by black vertical bars in the right-hand margin.



This symbol is used in illustrations to alert you to changes.

- ☞ The “LEERER MERKER Amendments” section lists the changes made since the previous edition.

Trademarks

All trademarks referring to software that is installed on Bosch products when shipped from the factory represent the property of the respective manufacturers.

When shipped from the factory, all installed software is protected by copyright. It may therefore be duplicated only with prior permission by Bosch or in accordance with the licensing agreements with the respective manufacturer or copyright owner.

MOBY® is a registered trademark of Siemens AG.

Notes:

2 MOBY I/F Channel Module Functions

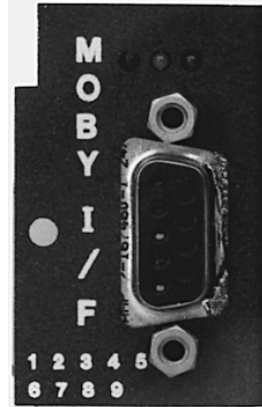

The MOBY I/F Channel Module is a component of the MOBY®-I Mobile Data Storage system manufactured by Siemens AG. The data storage system encompasses

- the MOBY I/F Channel Module,
- the SLG Read/write unit, and
- the MDS Mobile Data Storage unit.

In addition, for the purpose of startup and testing the MOBY I/F, the STG 4F Service and Testing unit is available.

With regard to its functionality, the Bosch MOBY I/F Channel Module corresponds to the Siemens CM 423 Channel Module.

 **For detailed information about the MOBY-I Identification System, refer to the documentation provided by Siemens AG. The following catalogue may provide introductory reading:**

**MOBY
Identification System MOBY-I
E86060-K6910-A101-A2**

The MOBY I/F Channel Module controls the data exchange between the PBK Peripheral Bus Interface Module and the SLG Read/write unit. The MOBY I/F module supports the Filehandler file management system Filehandler.

The Filehandler file management system facilitates a simple means of managing files on the MDS. The system has the characteristics of a DOS operating system:

- Addressing data via file names.
- Files of different sizes can be managed.
- Access rights can be assigned to files.

To handle the data transfer, the use of the PBK5MIF Software Module is required. The PBK5MIF must be integrated into the PLC program.

☞ The PLC program may utilize only the PBK5MIF module for data access! All other types of read or write accesses to the addresses on the PBK Peripheral Bus Interface Module will cause synchronization loss!

The intelligent SLG Read/write unit is connected to the peripheral bus of the control unit via the MOBY I/F Channel Module and the PBK Peripheral Bus Interface Module.

Data is exchanged between SLG and MDS inductively via frequency modulation.

Inserting a MOBY I/F in a PBK and connecting to the Read/write unit

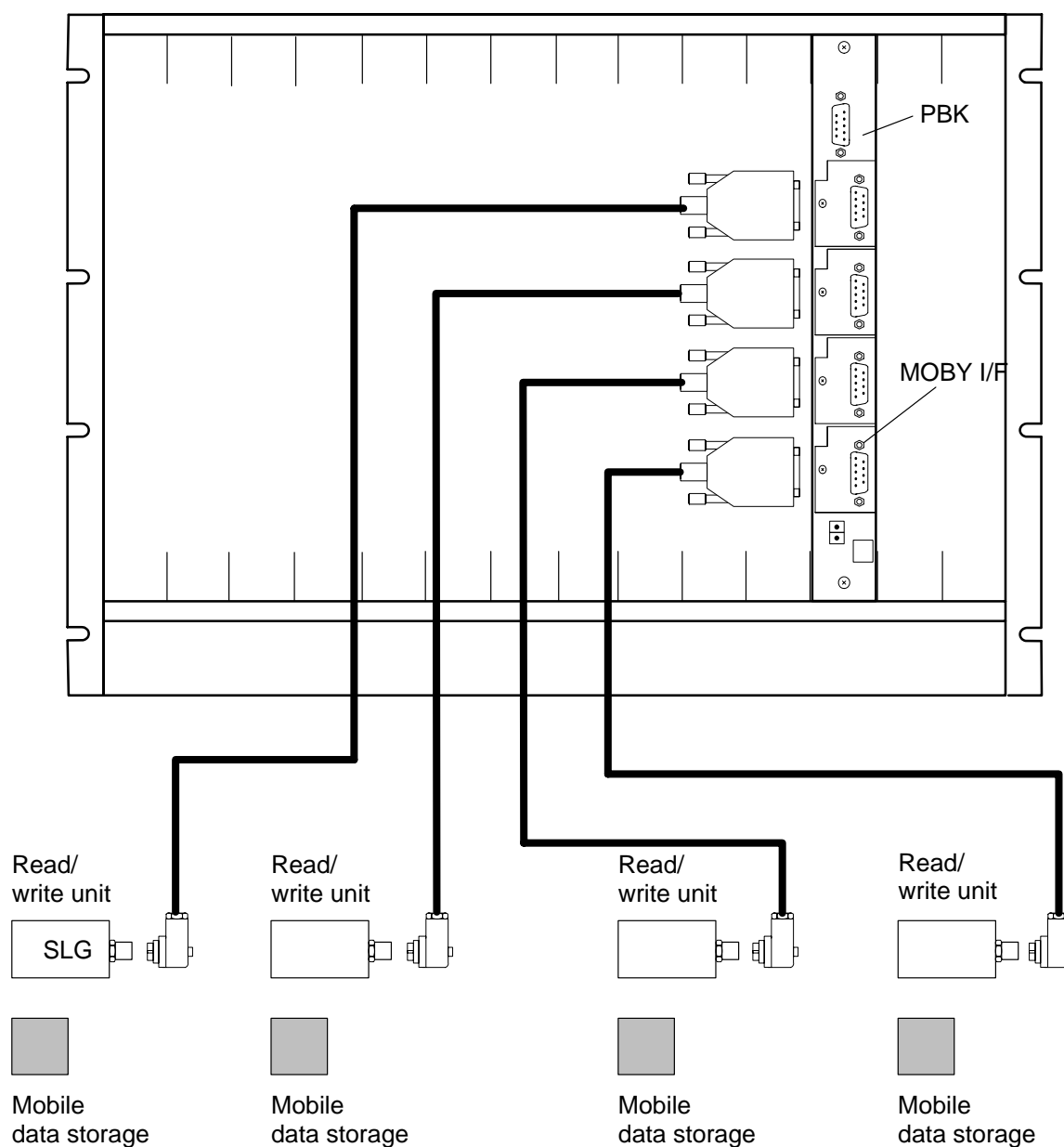

For a detailed description of the PBK, refer to the following documentation:
PBK Peripheral Bus Interface Module
Module Description
Order no. 1070 072 133

3 Operating the MOBY I/F Channel Module



CAUTION
 Observe all ESD protection measures when handling the MOBY I/F Channel Module and the PBK Peripheral Bus Interface Module! Prevent electrostatic discharges!

3.1 Construction, Indicators, Settings

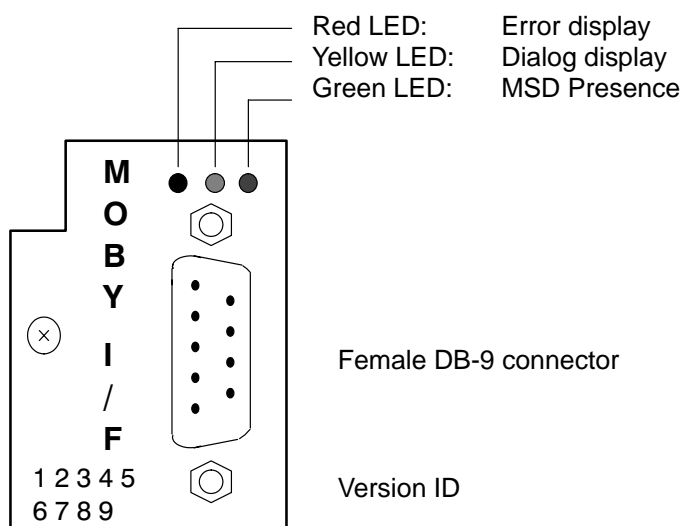

Red LED

The red LED serves as an error display. The error display provides assistance during system startup and service procedures. Without exception, the error detected most recently is displayed. The error display can be reset only by actuating the STOP/RUN switch on the control unit, or with the use of the STG 4F Service and Testing unit.

MOBY I/F Hardware Errors

Subsequent to a hardware error, the channel module cannot be addressed by the PBK5MIF module. The error is not sent to the program. The MOBY I/F Channel Module must be replaced.

| Red LED | Cause |
|------------------------------------|---|
| Steady bright illumination | Defective PROM onboard the MOBY I/F |
| Steady dim illumination | Defective CPU onboard the MOBY I/F |
| Medium-slow flashing, approx. 4 Hz | Defective external RAM onboard the MOBY I/F |
| Rapid flashing, approx. 8 Hz | Defective dual-port RAM module |

Flashing pattern

The red LED indicates the errors via a series of different pulse patterns. The number of flashes between long pauses determines the type of error.

 **A flashing error indicator in the normal operating mode does not mean anything provided that the system continues to operate correctly.**

| Red LED | Error code | Brief description | Cause |
|---|------------|---|---|
| Flashing pattern Number of light pulses | | | |
| 0 | 00 | No error | |
| 1 | D001 | MOBY I/F is not communicating with the PLC | PLC program |
| 2 | C006 | MDS Presence error, no MDS present | PLC program |
| 3 | B001 | Fault in the connection to the Read/write unit | Hardware: MOBY I/F, cable, STG |
| 4 | C002 | Fault in the RAM of the MDS, not initialized | MDS: user program |
| 5 | C007 | Unable to interpret command from the MOBY I/F | PLC program |
| 6 | C008 | Too many synchronization attempts | Contaminated environment, hardware: Read/write unit, MDS |
| 7 | C009 | Too many send errors | Read/write unit environment, hardware: Read/write unit |
| 8 | C010 | CRC send error | Read/write unit environment, hardware: Read/write unit, MDS |
| 9 | C011 | INIT: CRC error upon receipt of end acknowledgement | Read/write unit environment |
| 10 | C012 | INIT: Unable to initialize MDS | MDS |
| 11 | C013 | INIT: Timeout waiting for acknowledgement | MDS, Read/write unit environment |
| 12 | C014 | INIT: Unable to initialize the MDS | MDS |
| 13 | C015 | CMD: Address error | PLC program |
| 14 | C016 | ECC mode: Faulty data received from MDS | MDS, PLC program |

| Red LED | Error code | Brief description | Cause |
|---|------------|---|------------------------------------|
| * | C017 | not used | |
| * | 10 | not used | |
| * | 11 | not used | |
| * | 12 | not used | |
| * | 13 | not used | |
| * | 14 | not used | |
| * | 15 | not used | |
| * | 16 | not used | |
| * | 17 | not used | |
| * | 18 | not used | |
| * | 19 | MOBY I/F: Previous command is still active | PLC program |
| * | 1 A | PBK5MIF: Faulty parameter settings for this MDS type | PLC program |
| 27 | 1B | STG: Serial driver onboard MOBY I/F: Receive error (will not be cleared through intervention via STG) | Hardware: STG, MOBY I/F, STG cable |
| 28 | 1C | STG: Serial driver onboard MOBY I/F: Sendefehler (will not be cleared through intervention via STG) | Hardware: STG, MOBY I/F, STG cable |
| * | 1D | CMD: Insufficient RAM in MOBY I/F | PLC program |
| * | 1E | CMD: Faulty AB-byte: Wrong data type upon Reset | PLC program |
| * | 1F | not used | |
| * Error is not indicated by the red LED | | | |
| ** Error code is transferred to the PBK5MIF software module, and can be interpreted by the PLC program. | | | |

Yellow LED

Rapid and irregular flashing indicates an active dialog with the Read/write unit or MDS. When MDS Presence LED is ON, the yellow LED shows steady illumination.

Green LED

The green LED represents the MDS Presence indicator. When illuminated, the green LED indicates that an MDS is within range of the Read/write unit.

- LED Off : No MDS is present.
- LED On : An MDS currently within range of the Read/write unit.

Female DB-9 connector

The female DB-9 connector is used to connect the SLG Read/write unit to the MOBY I/F channel module. This is an interface RS-422.

| Pin | Designation |
|---------|--------------|
| 1 | free |
| 2 | + Send |
| 3 | + Receive |
| 4 | free |
| 5 | - Receive |
| 6 | - Send |
| 7 | Ground (0 V) |
| 8 | + 24 V |
| 9 | free |
| Housing | Screen |

To prevent the induction of noise into the connection, install the connecting cable between MOBY I/F and Read/write unit separate from other interference-prone cables. A minimum distance of 10 cm (4 in.) shall be maintained.

In the event that factory-supplied original cables are not used between MOBY I/F and Read/write unit, the cables utilized shall be of the twisted-pair type. It is essential that the twisted-pair cable consists of forward and return line, so that the flowing currents add up to zero. The entire cable must be screened and connected in accordance with the factory guidelines issued by Siemens.

SLG Read/write unit

The SLG Read/write unit transfers the data to the MDS via a frequency-modulated inductive link at a carrier frequency of 1.84 MHz. Interference may be injected into the data connection between the MOBY I/F and the Read/write unit via antenna integrated in the Read/write unit. For this reason, a suitably interference-free environment shall be provided especially in the proximity of the Read/write unit.

Normal operating mode / Testing mode

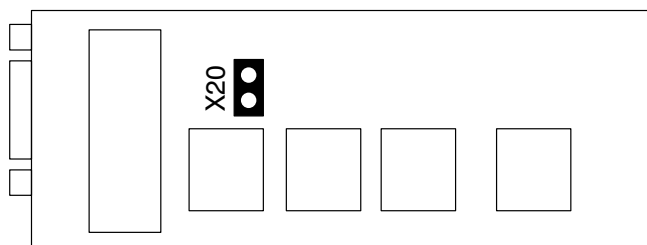

Plug-in jumper X20

**CAUTION**

Observe all ESD protection measures when handling the MOBY Channel Module and the PBK Peripheral Bus Interface Module! Prevent electrostatic discharges!

The X20 plug-in jumper on the MOBY I/F is used to switch between Normal mode and Testing mode. With the use of Testing mode, malfunctions can be detected at the time of initial system startup.

In the Normal operating mode, the MOBY I/F module will send a data message to the Read/write unit until the message is accepted. If any interference occurs during transmission to the Read/write unit, it may take some time before a message is successfully received. The user is not made aware of the number of unsuccessful attempts made by the MOBY I/F module to transmit the message.

In Testing mode, the data transmission is aborted after the third unsuccessful attempt. The red LED will indicate flashing pattern 6, representing error code 08, refer to the table on page 3-2. This enables the user to determine whether or not the data transmission to the Read/write unit is impeded by an interference-inducing environment.

X20 plug-in jumper:

- Normal mode: pins open
- Testing mode: pins bridged

3.2 Installing the MOBY I/F

**CAUTION**

Ensure that installation instructions for the MOBY I/F are precisely followed! Faulty installation procedures may destroy the channel module.

- ★ Switch OFF controller power supply unit and 24 V power supply.
 - ★ Remove the connector of the 24 V power supply from the front panel of the PBK.
-

**CAUTION**

Observe all ESD protection measures when handling the MOBY I/F Channel Module and the PBK Peripheral Bus Interface Module! Prevent electrostatic discharges!

- ★ Loosen both knurled screws of the PBK, and pull the module out of the module rack.

Always plug the first channel module into slot M1. To improve heat dissipation, module slots must be filled from the bottom in an upward progression.

- ☞ **In the event that the STG 4F Service and Test unit is used, a MOBY I/F module must be installed in slot M1 of the PBK.**

- ★ Unscrew the dummy cover and keep it in a safe place.
- ★ Carefully push the channel module into the slot. When doing so it is essential that
 - it is squarely aligned in the guide grooves.
 - it is fully seated in the plug-in strip.

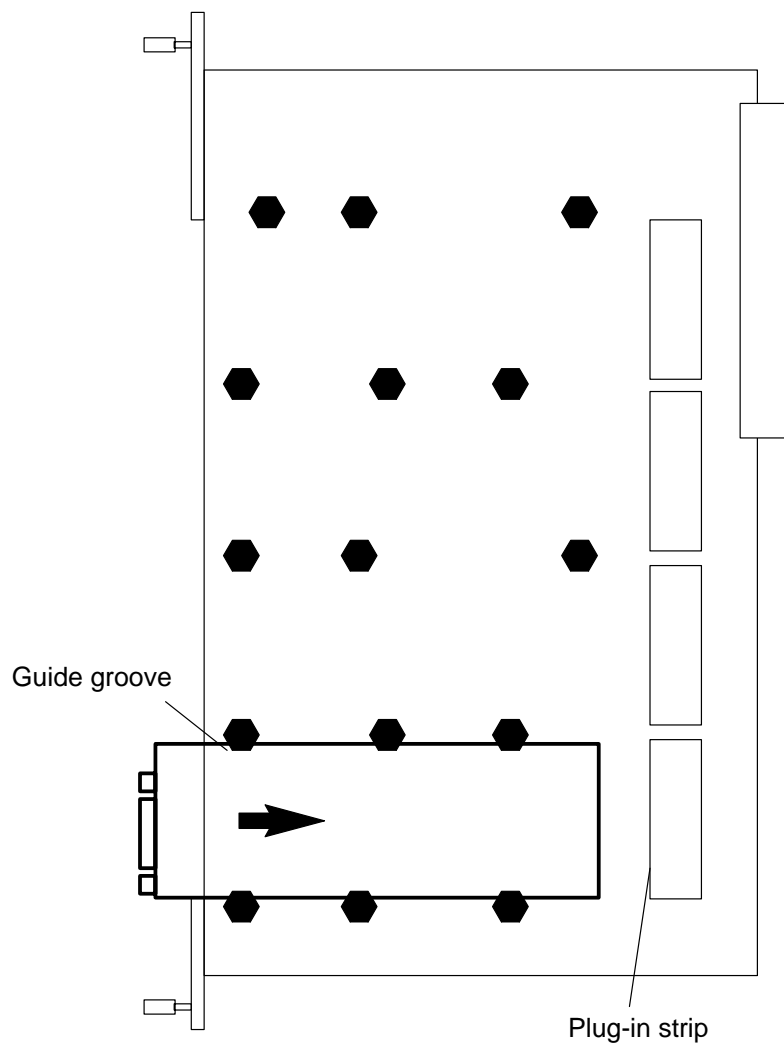

- ★ Fasten channel module to the front panel of the PBK.



CAUTION

Prior to Power-On, check the channel modules for correct seating!
Channel modules may be destroyed by canted installation!

- ★ Close all empty PBK module slots with dummy covers.
- ★ Slide the PBK into the module rack, and tighten knurled screws.
- ★ Connect 24 V power supply to the PBK front panel.

Disconnecting the MOBY I/F

- ★ Switch OFF controller power supply unit and 24 V power supply.
- ★ Remove the connector of the 24 V power supply from the front panel of the PBK.
- ★ Loosen SUB-D connector screws at channel modules, and remove connectors.
- ★ Loosen both knurled screws of the PBK and pull the module out of the module rack.
- ★ Rest the PBK on an ESD-proof worktop.
- ★ Redmove the retaining screw of the channel module.
- ★ Grasp the channel module at the front panel, and carefully withdraw the module from the PBK.
- ★ Install a dummy cover or a new channel module.

3.3 X10 Connector for 24 V Power Supply

- ☞ **For details of the 24 V power supply, refer also to the following technical documentation:**
PBK Peripheral Bus Interface Module
Module Description
Order no. 1070 072 133

The only function of the 24 V connector labelled "X10" on the front panel of the PBK is to supply 24 V operating power to the channel modules. This voltage is provided to the channel modules via a filter and a 2 A fuse. The MOBY I/F modules use this power to supply the SLG Read/write unit.

- ☞ **On the PBK module, the chassis ground (0 V) of both the 24 V power supply and the 12 V power supply of the controller peripheral bus are electrically connected. For this reason, a separate 24 V power supply must be provided for the PBK to prevent malfunctions.**
- ☞ **The Read/write unit requires a supply voltage of at least 22 V! The supply voltage must therefore be more accurate than the specifications in IEC 1131.**

The 24 V power supply must meet the following conditions:

- Transformer featuring protective separation, as per DIN VDE 0551.
- Transformer with shielding winding.
- Ripple factor, as per DIN 19 240, max. 5 %.

In that case, the 24 V power supply will be rated as functional extra-low voltage (FELV), as per DIN VDE 0100 Part 410, Sect. 4.2 and/or DIN VDE 0113 Part 1, Sect. 5.1.2.3b.

All cables connecting the 24 V power supply must meet the following conditions:

- Installation must be at a distance from cables carrying higher voltages.
- Insulation must be designed for the highest occurring voltage, as per DIN VDE 0113 Part 1, Sect. 10.1.4.

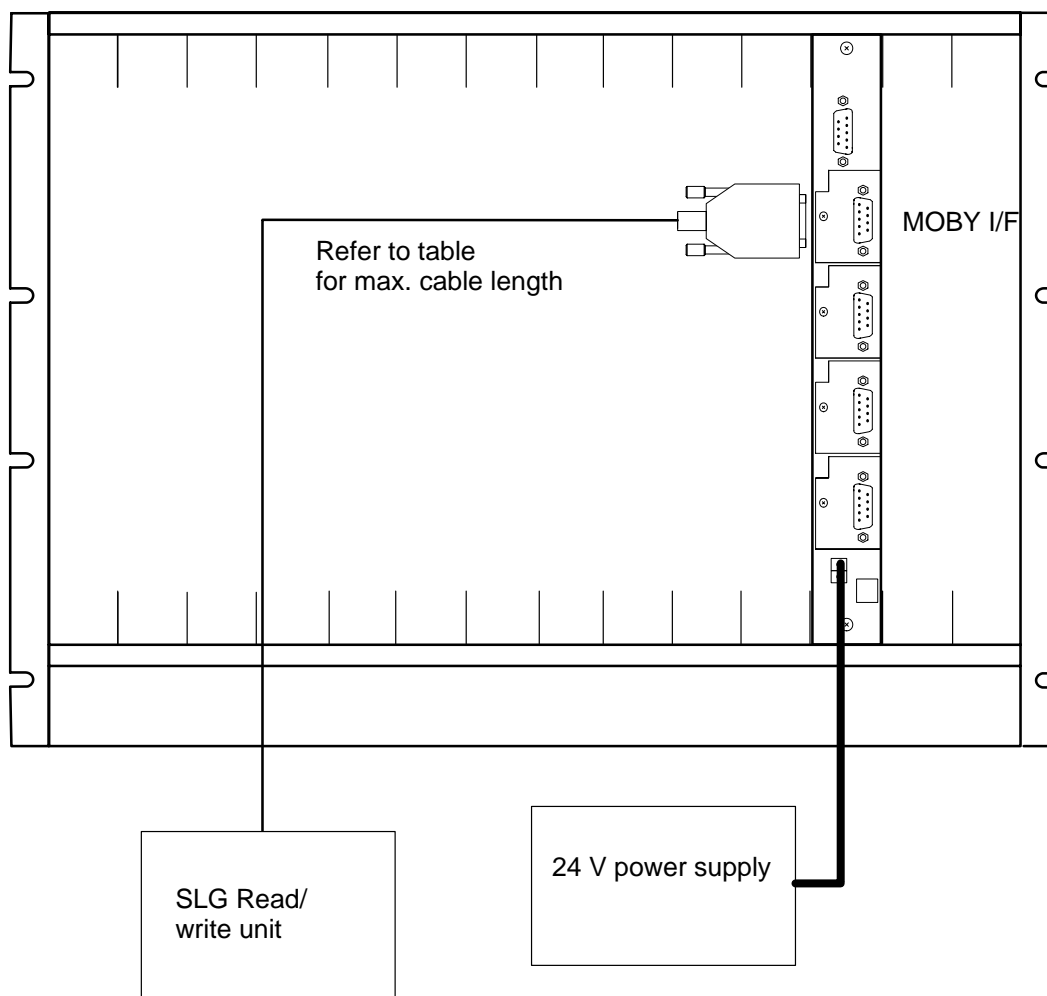

Cable lengths

Maximum cable lengths between MOBY channel modules and SLG Read/write unit:

- Independent of the conductor diameter, the data can be transmitted over a distance up to 1000 metres.
- The power supply of the SLG Read/write unit imposes maximum cable lengths, as shown in the following table:

| Conductor diameter | Voltage | Cable length [m] | | | | |
|--|---------|------------------|--------|--------|--------|--------|
| | | 0.3 mm | 0.5 mm | 0.8 mm | 1.0 mm | 1.4 mm |
| SLG 41 (I = 90 mA) $17\text{ V} \leq U_{\text{SLG}} \leq 30\text{ V}$ | 24 V | 120 | 350 | 900 | 1000 | 1000 |
| | 30 V | 250 | 720 | 1000 | 1000 | 1000 |
| SLG 42 (I = 180 mA) $20\text{ V} \leq U_{\text{SLG}} \leq 30\text{ V}$ | 24 V | 25 | 80 | 200 | 320 | 620 |
| | 30 V | 90 | 270 | 700 | 1000 | 1000 |
| SLG 43 (I = 250 mA) $20\text{ V} \leq U_{\text{SLG}} \leq 30\text{ V}$ | 24 V | 20 | 50 | 140 | 230 | 450 |
| | 30 V | 70 | 190 | 500 | 780 | 1000 |

To extend the maximum permitted distance between the MOBY I/F channel module and the SLG Read/write unit, a separate power supply to provide operating power to the SLG may be required. In this case, the data cables establish an electrical connection between the power supply of the SLG on the one hand, and the peripheral bus of the control unit and/or the 24 V power supply of the PBK on the other. This interconnection may cause a meshing of electrical potentials that is susceptible to failure. This problem can be prevented through the deployment of power supply units featuring electrical isolation.

SLG Read/write unit with separate 24 V power supply

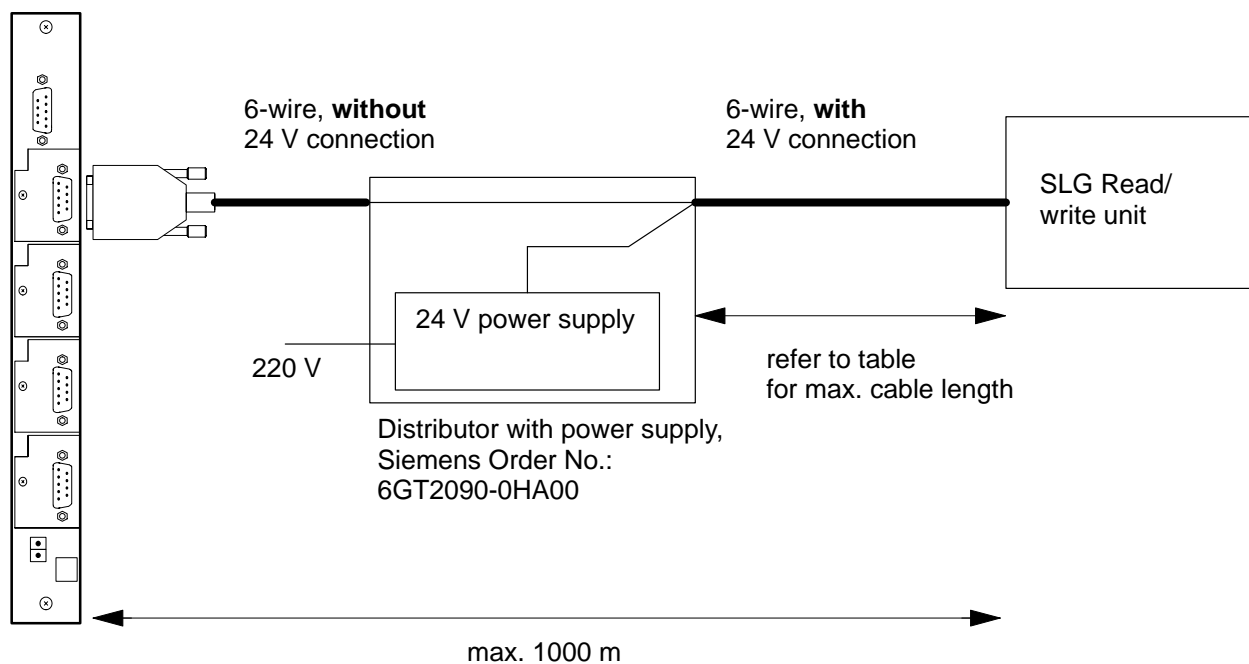

CAUTION
 The 24 V supply conductor, i.e., pin 2 on the Read/write unit male connector, must not be connected to the MOBY I/F!

Fan

The physical placement of the 24 V power supply for the SLG Read/write unit determines the thermal load on the PBK Interface Module.

For the MOBY I/F channel module, the following applies:

- Provided that the 24 V power supply of the Read/write unit is not connected via the 24 V connection at the PBK front panel but externally, a fan will not be required.
- If the PBK module supplies the 24 V operating power to the Read/write units, the following currents are permitted:
 - with fan : MOBY I/F channel module, max. 400 mA
 - without fan : Combined currents of all MOBY I/F, max. 550 mA

The following fan units can be used:

- Three-fan unit, Order no. 1070 062 325
- Two-fan unit, Order no. 1070 052 243

 **Refer also to the following technical documentation:**
PBK Peripheral Bus Interface Module
Module Description
Order no. 1070 072 133

3.4 STG 4F Service and Testing Unit

A special STG 4F Service and Test Unit is available for the MOBY I/F. The STG 4F is used for testing and system startup of both the MOBY I/F channel module and the SLG Read/write unit.

-  **The use of the STG 4F requires that a MOBY I/F channel module is installed in module slot M1 of the PBK interface module.**

The pin assignment of the female DB-9 connector of the X51 interface on the PBK is as follows:

| Pin | Designation |
|---------|--------------|
| 1 | free |
| 2 | + Send |
| 3 | + Receive |
| 4 | free |
| 5 | - Receive |
| 6 | - Send |
| 7 | Ground (0 V) |
| 8 | + 24 V |
| 9 | free |
| Housing | Screen |

Notes:

4 Module Specifications

| Specifications | MOBY I/F |
|--|--|
| Order no. | 1070 071 281 |
| Range of 24 V operating voltage | 20 through 30 V, short-time for 500 ms 35 V |
| Current draw <ul style="list-style-type: none">internally from 12 Vexternally from 24 V | typ. 70 mA max. 400 mA |
| Interface to SLG Read/write unit | RS-422, female DB-9 connector |
| Transmission rate to MDS | 19 200 Baud, asynchronous, 8 bit, even parity |
| Ambient temperature | 0 through + 55 °C |
| Storage temperature | - 20 through + 70 °C |
| Relative humidity at 25 °C | 95 % |
| Protection category, as per DIN 40 050 | IP 00 |

Notes:

A Appendix

A.1 Abbreviations

| Abbreviation | Meaning |
|---------------------|--|
| DOS | Disk Operating System |
| ESD | Electrostatically Sensitive Devices |
| ESD | Electrostatic discharge Abbreviation used with all designations referring to electrostatic discharges, e.g., ESD protection, ESD hazard, etc. |
| MDS | Mobile Data Storage |
| PBK | Peripheral Bus Interface Module |
| PBK5MIF | CL500 Function module for the PBK module and the MOBY I/F channel module |
| PE | Protective Earth |
| SLG | Read/write unit |
| STG 4F | Service and Testing unit |
| ZS | Central processing unit of controller |

A.2 Amendments

In this revised edition 102, amendments have been made to the former edition 101 on the following pages.

| Chapter | Page | Change |
|---------|------------------|---|
| 3 | 3-2 | Table of error codes |
| | 3-10 and 3-11 | Cable length |
| | 3-12 | Fan unit ordering information was supplemented. |

A.3 Index

Numbers

24 V power supply, 3-9, 3-10, 3-11, 3-12

A

Address error, 3-2
Ambient temperature, 4-1
Amendment, 1-7

C

Cable lengths, 3-10
Carrier frequency, 3-4
CMD, 3-2
Connecting cable, 3-4
CRC error, 3-2
CRC send error, 3-2

D

Data message, 3-5
Data storage, 2-2
See also MDS
Dialog, 3-3
Dialog display, 3-1
Disconnecting the MOBY I/F, 3-8
Documentation, 1-7
DOS operating system, 2-1
Dummy cover, 3-7, 3-8

E

Earthing wrist strap, 1-6
ECC mode, 3-2
Electrostatically sensitive devices, 1-6
EMC Directives, 1-1
Emergency-STOP devices, 1-5
Error code, 3-2, 3-5
Error display, 3-1
ESD, 1-6
– protection, 3-1, 3-5, 3-6
protection, 1-6
work station, 1-6

F

Fan, 3-12
Female DB-9 connector, 3-1, 3-4
File management system, 2-1
Filehandler, 2-1
Flashing pattern, 3-2, 3-5
Functional extra-low voltage, 3-9
Fuse, 3-9

G

Guide groove, 3-7

H

Hardware Errors, 3-2
Humidity, 4-1

I

Initial startup, 3-5
Installing the MOBY I/F, 3-6
Insulation, 3-9
Interface, 4-1
– RS-422, 3-4
– X10, 3-9
– X51, 3-13
Interference, 3-4
Isolation, – electrical, 3-11

L

LED
– green, 3-1, 3-3
– red, 3-1, 3-2, 3-5
– yellow, 3-1, 3-3
Low-voltage Directive, 1-1

M

Malfunction, 3-5
MDS, 2-1, 2-2, 3-2, 3-3, 3-4, 4-1
MDS Presence, 3-3
MDS Presence check, 3-3
MDS Presence error, 3-2
Meshing of electrical potentials, 3-11
Mobile Data Storage. *See* MDS
Mobile data storage, 2-2
MOBY(R)-I, 2-1
MSD Presence, 3-1

N

Normal operating mode, 3-4

O

Operating voltage range, – 24 V, 4-1

P

PBK, 2-1, 2-2, 3-6, 3-7, 3-9, 3-11, 3-13
PBK5MIF, 2-1, 3-2, 3-3
Peripheral Bus Interface Module. *See* PBK
Plug-in strip, 3-7
Power supply, – 24 V, 3-9, 3-10, 3-11, 3-12
Protection category, 4-1

Q

Qualified personnel, 1-2

R

Range of 24 V operating voltage, 4-1
Read/write unit, 2-2, 3-2, 3-3, 3-4, 3-5, 3-9, 3-11, 3-13
See also SLG
Ripple factor, 3-9

S

Safety instructions, 1-4
Send error, 3-2
Separation, – protective, 3-9
Service and Testing unit. See STG 4F
SLG, 2-1, 2-2, 3-4, 3-9, 3-10, 3-11
Spare parts, 1-5
Standard operation, 1-1
STG 4F, 2-1, 3-1, 3-6
Storage temperature, 4-1
Synchronization, 3-2

T

Testing mode, 3-4
Testing procedures, 1-5
Timeout, 3-2
Trademark, 1-7
Transformer, 3-9
Transmission rate, 4-1

V

Version ID, 3-1

X

X10, 3-9
X20, 3-5
X20 jumper, 3-5
X51, 3-13

Bosch Automation Technology

Australia

Robert Bosch (Australia) Pty. Ltd.
Head Office
Cnr. Centre - McNaughton Roads
P.O. Box 66
AUS-3168 Clayton, Victoria
Fax (03) 95 41 77 03

Great Britain

Robert Bosch Limited
Automation Technology Division
Meridian South Meridian Business Park
GB-LE3 2WY Braunstone
Leicestershire
Fax (01 16) 28-9 28 78

USA

Robert Bosch Corporation
Automation Technology Division
Fluid Power Products
7505 Durand Avenue
USA-Racine, Wisconsin 53406
Fax (414) 5 54-81 03

Canada

Robert Bosch Corporation
Automation Technology Division
6811 Century Avenue
CAN-Mississauga, Ontario L5N 1R1
Fax (905) 5 42-42 81

Robert Bosch Corporation
Automation Technology Division
Factory Automation Products
816 East Third Street
USA-Buchanan, MI 49107
Fax (616) 6 95-53 63

Robert Bosch Corporation
Automation Technology Division
Industrial Electronic Products
40 Darling Drive
USA-Avon, CT 0 60 01-42 17
Fax (860) 4 09-70 80

We reserve the right to make technical alterations

Your concessionary

BOSCH



Robert Bosch GmbH
Geschäftsbereich
Automationstechnik
Antriebs- und Steuerungstechnik
Postfach 11 62
D-64701 Erbach
Fax +49 (0) 60 62 78-4 28