



MDD Digital AC Servo Motors

Project Planning Manual

DOK-MOTOR*-MDD*****-PRJ1-EN-P



Title MDD Digital AC Servo Motors

Type of documentation Project Planning Manual

Documenttype DOK-MOTOR*-MDD*****-PRJ1-EN-E1,44 • 12.96

Internal file reference

- Mappe 12
- MDD-PJ.pdf
- 209-0069-4391-01

Reference This electronic document is based on the hardcopy document with document desig.: DOK-MOTOR*-MDD*****-PRJ1-EN-P • 11.96

The purpose of this documentation

This project planning documentation

- lists the technical data and performance features of the motor
- offers guidelines on the mechanical integration of the motor into the machine
- offers guidelines on the electrical integration of the motor into the machine
- lists the available options
- lists order information of the motor and its electrical accessories
- offers guidelines on the transportation, handling and storage of the motor

Change sequence

Document code of present editions	Release date	Comment
DOK-MOTOR*-MDD*****-PRJ1-EN-E1,44	Dez 96	1st edition

Copyright © INDRAMAT GmbH, 1996

Copying this documentation, and giving it to others and the use or communication of the contents thereof without express authority are forbidden. Offenders are liable for the payment of damages. All rights are reserved in the event of the grant of a patent or the registration of a utility model or design (DIN 34-1).

The electronic documentation (E-Doc) may be copied as often as needed if such are to be used by the consumer for the purpose intended.

Validity All rights are reserved with respect to the content of this documentation and the availability of the product.

Published by INDRAMAT GmbH • Bgm.-Dr.-Nebel-Straße 2 • D-97816 Lohr
 Telephone 09352/40-0 • Tx 689421 • Fax 09352/40-4885
 Dept. ENA (UW, FS)

Table of Contents

	Page
1. MDD Digital AC Servo Motors	7
<hr/>	
2. Technical Explanations	12
<hr/>	
2.1. Ambient Conditions	12
2.2. Mechanical Features	16
2.3. Electrical Features	23
2.4. Motor feedback	25
2.5. Torque-Speed Characteristics	27
3. MDD 021	29
<hr/>	
3.1. Technical Data	29
3.2. Torque-Speed Characteristics	30
3.3. Shaft Load Capacity	31
3.4. Dimensional Data	32
3.5. Available Versions	34
4. MDD 025	36
<hr/>	
4.1. Technical Data	36
4.2. Torque-Speed Characteristics	37
4.3. Shaft Load Capacity	39
4.4. Dimensional Data	40
4.5. Available Versions	44
5. MDD 041	46
<hr/>	
5.1. Technical Data	46
5.2. Torque-Speed Characteristics	47
5.3. Shaft Load Capacity	49
5.4. Dimensional Data	50
5.5. Available Versions	52
6. MDD 065	54
<hr/>	
6.1. Technical Data	54
6.2. Torque-Speed Characteristics	56
6.3. Shaft Load Capacity	59

6.4.	Dimensional Data	60
6.5.	Available Versions	62
7.	MDD 071	64
<hr/>		
7.1.	Technical Data	64
7.2.	Torque-Speed Characteristics	66
7.3.	Shaft Load Capacity	69
7.4.	Dimensional Data	70
7.5.	Available Versions	72
8.	MDD 090	74
<hr/>		
8.1.	Technical Data	74
8.2.	Torque-Speed Characteristics	76
8.3.	Shaft Load Capacity	79
8.4.	Dimensional Data	80
8.5.	Available Versions	82
9.	MDD 093	83
<hr/>		
9.1.	Technical Data	83
9.2.	Torque-Speed Characteristics	85
9.3.	Shaft Load Capacity	91
9.4.	Dimensional Data	92
9.5.	Available Versions	94
10.	MDD 112	96
<hr/>		
10.1.	Technical Data	96
10.2.	Torque-Speed Characteristics	98
10.3.	Shaft Load Capacity	105
10.4.	Dimensional Data	106
10.5.	Available Versions	108
11.	MDD 115	110
<hr/>		
11.1.	Technical Data	110
11.2.	Torque-Speed Characteritics	112
11.3.	Shaft Load Capacity	117
11.4.	Dimensional Data	118
11.5.	Available Versions	120

12. Electrical Power Connection	121
12.1. Terminal Diagram	121
12.2. Connector to Cable Allocation	122
12.3. Power Connector (Motor Power Connector)	127
12.4. Motor Power Cable	128
12.4.1. Technical Data	128
12.4.2. General Data	128
12.4.3. Ready-made motor power cable	129
12.4.4. Order Guidelines	134
13. Electrical Motor Feedback Connections	135
13.1. Terminal Diagram	135
13.2. Feedback Connector	136
13.3. Feedback Cable	136
13.3.1. Technical Data	136
13.3.2. Ready-Made Feedback Cables	137
13.3.3. Order Guidelines	137
14. Condition at Delivery	138
15. Identifying the Merchandise	139
16. Storage, Transport and Handling	141
17. Mounting and Installation Guidelines	144
18. Service Guidelines	145
18.1. Contacting Customer Service	145
18.2. Repair Card	146
19. Index	147

1. MDD Digital AC Servo Motors

This section offers an overview of the range of applications, power features, parts and the construction of the MDD AC servo motors.

Applications Together with intelligent digital drive controllers from INDRAMAT, digital AC servo motors of the MDD series create cost-effective and rapid-response automatization systems.

Drives with MDD AC servo motors are especially well-suited for use in tool, textile, printing and packaging machines, as well as robotics, handling equipment and transfer facilities. MDD motors assure high contouring accuracies at high feedrates, in particular when used for cutting in high speed ranges.

A series of nine motors with different continuous torques and speeds are available for the most varying of applications. Using this extensive product program means it is possible to realize, both technically and cost-effectively, the most optimum solution for just about any application.

Due to their slender construction and very high power density, the following digital AC servo motors are used with screwing applications, auxiliary axes and tool changing devices:

- MDD 021
- MDD 025
- MDD 041

For highly-dynamic applications such as roller feeds for pressing, punching and nibbling machines as well as tool changing devices, the following AC servo motors are especially used because of their very high power density:

- MDD 065
- MDD 071
- MDD 093
- MDD 115

For high-precision applications where an extreme degree of synchronism is required (e.g. in grinding machines), the following motors are especially suited:

- MDD 090
- MDD 112

Overview of the power levels

Figure 1.1 depicts the available motors with the power features "continuous torque at standstill M_{dN} " and "nominal speed n ".

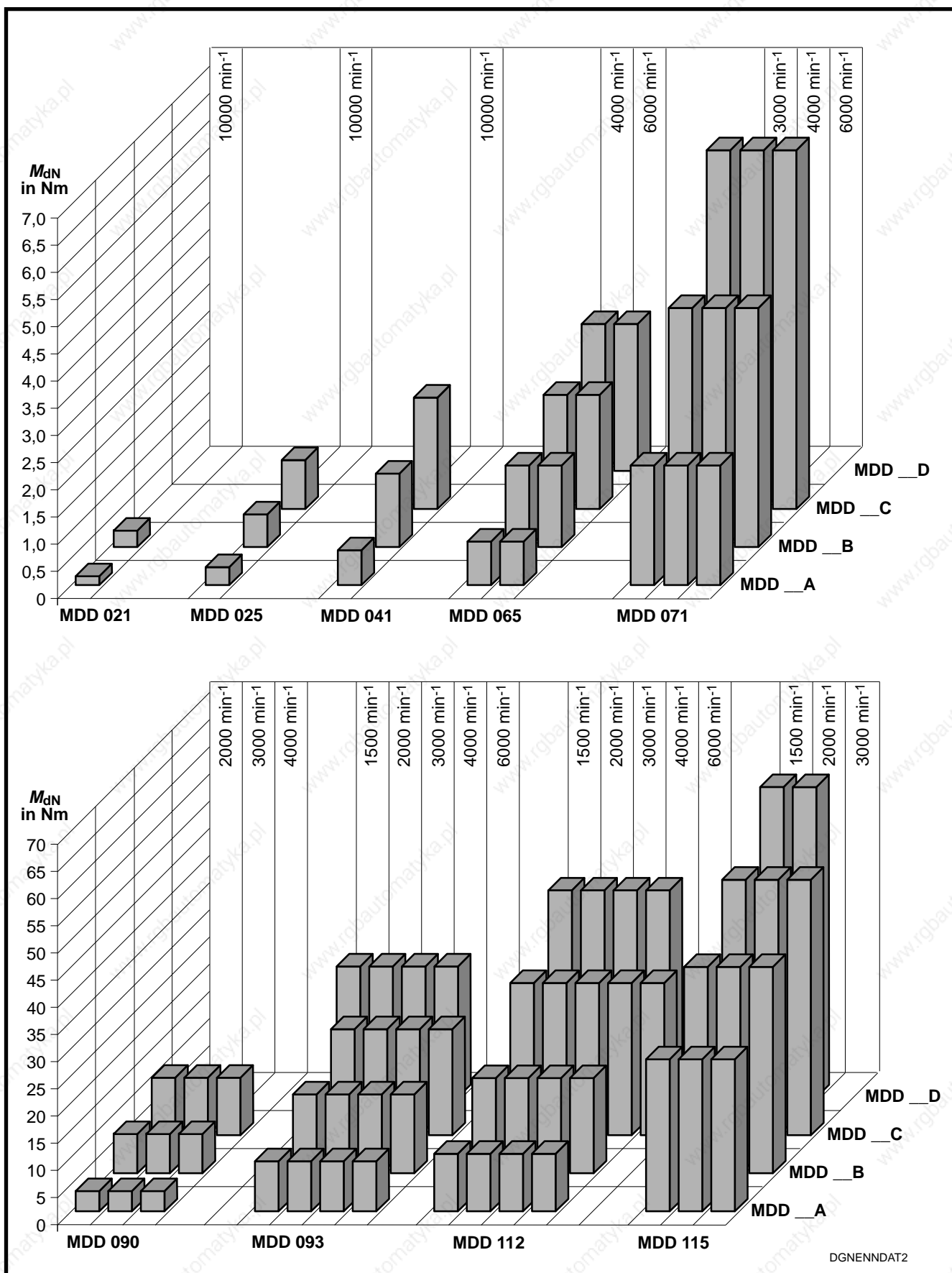

Fig. 1.1: Power levels

Construction and components of the motors

The digital MDD AC servo motors are permanent magnet-excited synchronous motors with electronic commutation. The permanent magnets of the rotor are made of rare-earth or iron oxide magnetic materials. The use of such materials makes it possible to construct a motor with low inertia.

Figure 1.2 depicts the principle of construction and the components of the MDD AC servo motor.

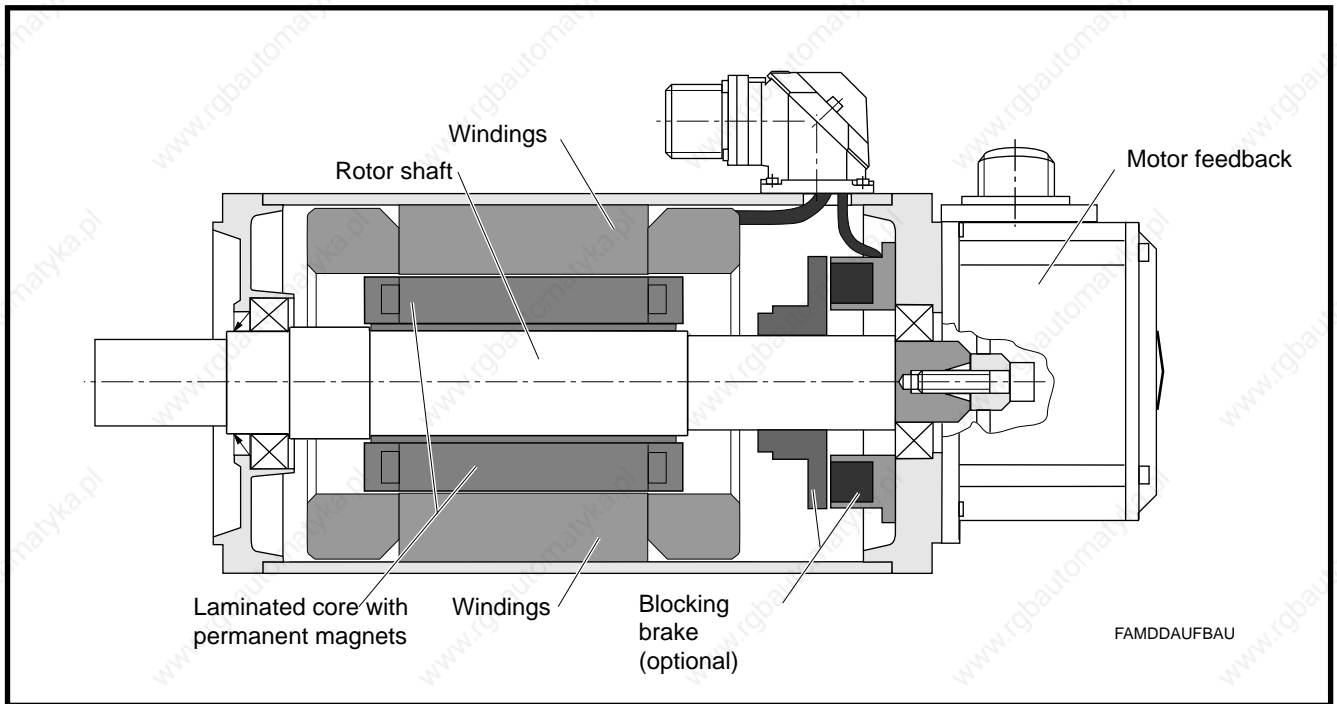

Fig. 1.2: The construction of an MDD AC servo motor

Operating reliability

The **high degree of operating reliability** is the result of the following constructional features of MDD motors:

- Maintenance-free operation as a result of:
 - a brushless design of the motor and
 - the use of life-time lubricated bearings.
- Can be used directly within the working area of the machine even under poor environmental conditions (e.g., affects of coolants or soluble oil emulsions):
 - because the motor housing is completely sealed and
 - the connections for the motor power cable and the feedback cable are constructed as per protection category IP 65.
- Motor temperature monitoring by means of a temperature sensor built into the motor windings prevents overload damage.

Performance data The motors are characterized by high performance data, which are described in detail as follows:

- High dynamics due to favorable torque-inertia ratio.
- High overload capabilities due to efficient heat conduction from the stator windings to the outside wall of the motor housing.
- Peak torque is utilized over a wide speed range.
- High power to weight ratio because of the compact construction.
- High cyclic load capacity permits continuous start-stop operations with high repetition rates. This is due to the electronic commutation of the motor.
- High synchronous operation features. This is achieved by the sinusoidal application of current together with high motor feedback resolution.

Installation on the motor The **installation** of the motors on the machine **is simple**.

- Direct attachment of pinions and belt pulleys to the shaft because the design makes it possible to apply high radial loads.
- There is a defined load assimilation of outside forces at the motor shaft. This means that the floating bearing of side "A" of the motor absorbs the radial forces, while the fixed bearing of side "B" absorbs the axial forces.
- The motor can be installed in any orientation.
- Flange design with throughholes permits mounting as per design IM B5, or as per design IM B14 with threads in the flange.
- A wide variety of ready-made cables is available eliminating additional installation work.

Cooling Some motor series are available with surface cooling to accommodate extreme loads. A summary of the blower options available for each series is outlined in section 2.2.

Blocking brake The MDD motors are available either with or without a blocking brake. The MDD 021 is the only exception as it is not available with blocking brake.

The blocking brake makes it possible to clamp or hold the output shaft at a standstill. This means that the axis is brought to a safe standstill when power is off.

Output shaft The output shaft is available in two different designs:

- as a plain shaft for non positive shaft-hub connections and
- shafts with keyways for form-fitting shaft-hub connections.

Motor feedback The motors are equipped with a motor feedback especially developed and designed for this line. This feedback enables position and speed evaluation and detection of rotor position. It is available with

- either relative or
- absolute position detection.

The motor feedback is either a "resolver feedback" or a "digital servo feedback" depending on the motor line.

Electrical Connections Both the power and the motor feedback cables are directly connected to the motor by means of connectors on the corresponding flanged sockets.

Labelling the Sides To make sure that the sides of the MDD motor are unequivocally labelled and that there can be no confusion, they have been fixed and depicted in Figure 1.3.

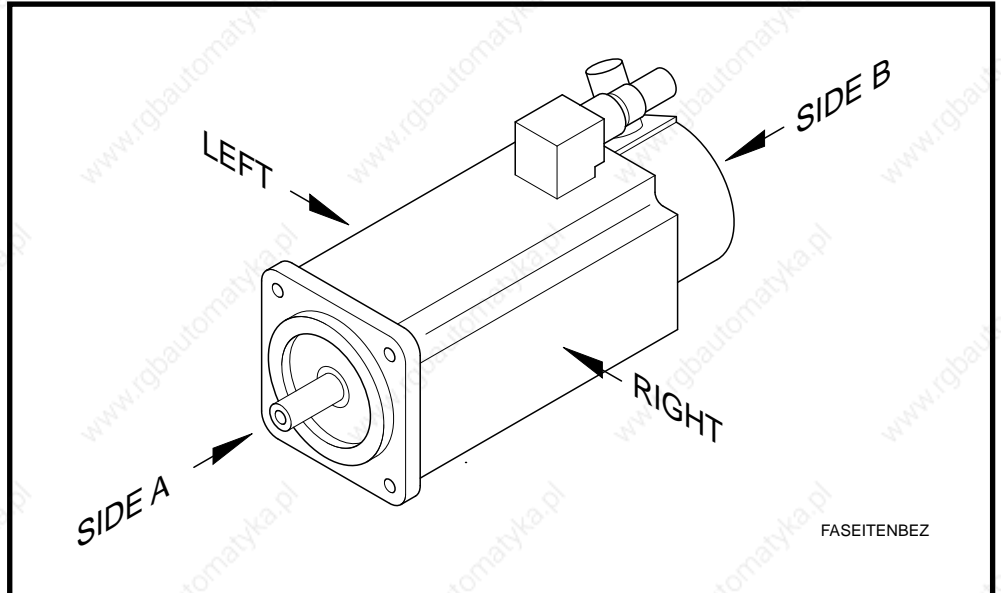

Fig. 1.3: Fixing and designating the sides of an MDD servo motor

2. Technical Explanations

This section outlines a description of the ambient conditions, the mechanical and electrical features of the motor as well as the motor feedback. Section 2.5 offers important details about the torque-speed characteristics curves which are, in turn, depicted for each type of motor in sections 3.2, 4.2 and through to 11.2.

2.1. Ambient Conditions

Installation elevation and ambient temperatures

The output data outlined in the section "Technical Data" are achieved under the following conditions:

Ambient temperature: 0° to + 45 °C

Installation elevation: 0 to 1000 meters above sea level

If the conditions deviate from the values, then the output data will decrease as depicted in the diagrams shown in Figure 2.1. If higher ambient temperatures and higher installation elevations occur simultaneously, then the load factors f_T and f_H must be multiplied.

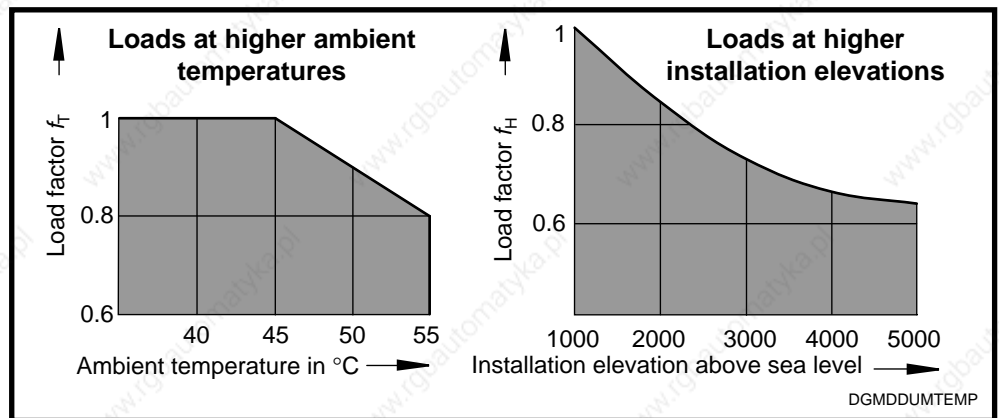

Fig. 2.1: Load capabilities at higher ambient temperatures and higher installation elevations

Protection Category

The MDD motors are protected by their housing and covers which in construction and design adhere to the guidelines found in DIN 40050 and protect

- against contact to high voltage with motor parts either moving or alive (contact guards),
- the penetration by extrinsic objects
- and the penetration of water.

The protection categories are laid down by the abbreviation IP (International Protection) and two numbers for the type of protection, for example, IP 40.

The first number represents the degree of protection afforded against contact and penetration by extrinsic objects (see Figure 2.2). The second number represents the degree of protection afforded against the damaging penetration by water (see Figure 2.3).

Figure 2.4 depicts the range of the protection categories as applicable to MDD motors.

First number	Protection against contact and penetration by objects
0	Little or no protection.
1	Protection against penetration by extrinsic objects with a diameter exceeding 50 mm. No protection against deliberate access, e.g., by a hand. Will keep larger body surfaces out, however.
2	Protection against penetration by extrinsic objects with a diameter exceeding 12 mm. Will keep fingers or similar objects out.
3	Protection against penetration by extrinsic objects with a diameter exceeding 2.5 mm. Keeps out tools, wiring or similar objects thicker than 2.5 mm.
4	Protection against penetration by extrinsic objects with a diameter exceeding 1 mm. Keeps out tools, wiring or similar objects thicker than 1 mm.
5	Protection against damaging dust. Complete penetration by dust is not prevented, but the dust may not be permitted to penetrate to the extent that the operation of the electrical equipment is in any way hindered (protected against dust). Complete protection against penetration by extrinsic objects.
6	Protection against the penetration of dust (dust-free). Complete protection against penetration by extrinsic objects.

Fig. 2.2: Protection grades for contact and penetration as per DIN 40 050, section 2 (edition dated 6/72)

Second number	Protection against Water
0	Little or no protection.
1	Protection against vertically dripping water (dripping or trickling water). It may not have any destructive affects.
2	Protection against vertically dripping water. It may not have any adverse affects on electrical equipment tilted up to 15° in contrast to its normal position (water dripping or trickling at an angle).
3	Penetration against water falling at an angle of up to 60°. Does not permit any damaging affects (sprayed water).
4	Protection against water sprayed at the equipment (housing) from all directions. Does not permit any damaging affects (splashwater).
5	Protection against a jet of water sprayed from a nozzle onto the equipment (housing) from all directions. Does not permit any damaging affects (jet of water).

Fig. 2.3: Protection grades for water as per DIN 40 050, section 2 (edition dated 6/72)

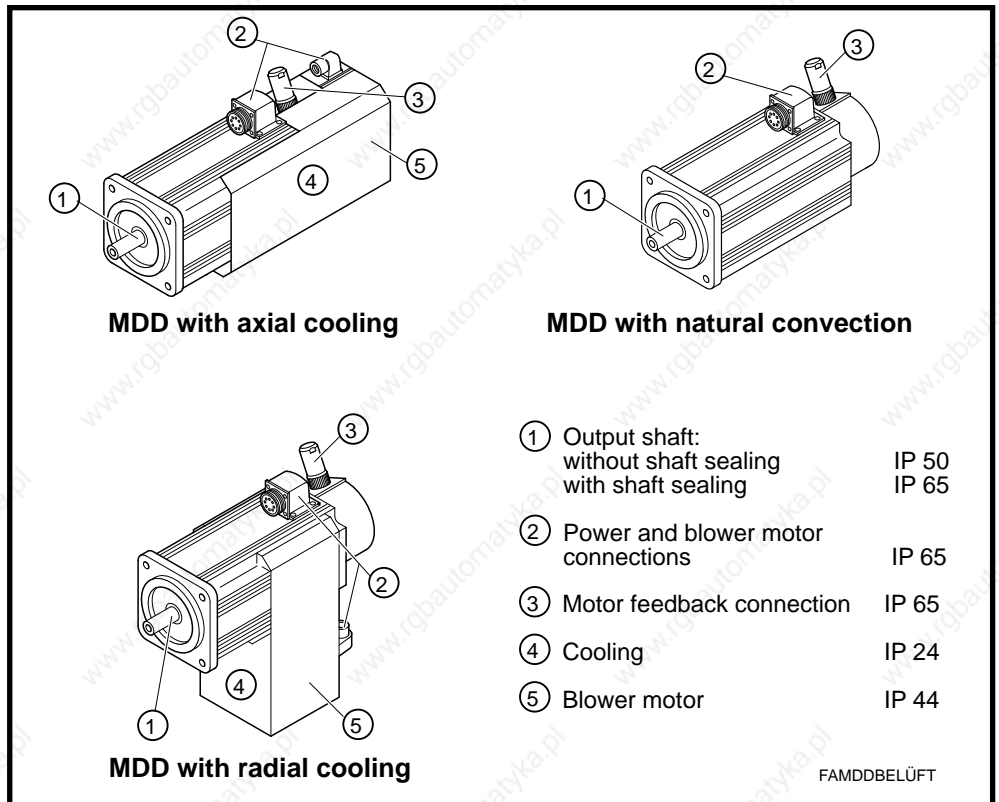

Fig. 2.4: Range of protection categories for MDD motors

Mechanical ambient conditions

MDD servo motors can be operated in a stationary manner under weather-proofed conditions as per IEC 721-3-3, the 1987 edition, or EN 60721-3-3, the 6/1994 edition:

- as per class 3M1 respective the longitudinal axis of the motor and
- as per class 3M6 respective the lateral axis of the motor.

The maximum values stated in Figure 2.5 thus apply to transportation and operation of MDD servo motors.

Environmental variables		Unit	Maximum values longitudinal axis	Maximum values lateral axis
sinusoidal oscillations	excursion amplitude	mm	0.3	7.0
	frequency range	Hz	2 to 9	2 to 9
	acceleration amplitude	m/s ²	1	20
	frequency range	Hz	9 to 200	9 to 200
shocks	total shock-response spectrum	-	type L per IEC 721-1 ed. 1990 table 1, section 6	type II per IEC 721-1 ed. 1990 table 1, section 6
	reference acceleration (in IEC 721-1 named peak acceleration)	m/s ²	40	250
	duration	ms	22	6

Fig. 2.5: Maximum values of the environmental variables



MDD servo motors are only suited for such extreme demands as is the case with punching, pressing, press feeds and similar applications, if shock-damped mounted or mounted shock decoupled.

We cannot recommend a generally applicable solution for shock-damped mounting. It is dependent on the respective construction of the machine and the results of metrological tests.

Housing coat The housing of the MDD motors is painted with a black prime coating. An additional layer of paint can cover this prime coat. The thickness of the layer may, however, not exceed 40 µm.

The coat is resistant to:

- weathering, yellowing and chalky build-ups as well as
- diluted acids and lyes.

The coat can, however, peel if the housing is frequently cleaned with a steam cleaner.

2.2. Mechanical Features

Construction and mounting orientation

The mounting flange is designed, in all types of motors, in such a way that mounting as per Design B5, i.e., a mounting flange with throughholes, is possible.

Mounting mode as per Design B14, i.e., mounting flange with threads, is **additionally** possible with the following motors:

- MDD 021
- MDD 041
- MDD 090
- MDD 093
- MDD 112
- MDD 115

Figure 2.6 demonstrates the ways that the motors can be mounted to the machine as per DIN 42950, section 1 (edition dated 8/77).







Construction	Permissible mounting orientations as per DIN IEC 34-7		
B05	 IM B5	 IM V1	 IM V3
B14	 IM B14	 IM V18	 IM V19

Fig. 2.6: Additional mounting orientations



In the case where the motors are mounted in orientations IM V3 and IM V19, it is necessary to prevent liquids from collecting at the output shaft over extended periods of time. Even the use of a shaft sealing does not absolutely prevent liquids from penetrating, along the output shaft, into the housing of the motor.

Pilot diameter To generate compatibility with the motors of other manufacturers, it is possible to also select a mounting flange with a customized pilot/centering diameter in addition to the standard types. This is possible only with some of the motors. The choices and appropriate dimensions are listed in the table in Figure 2.8.

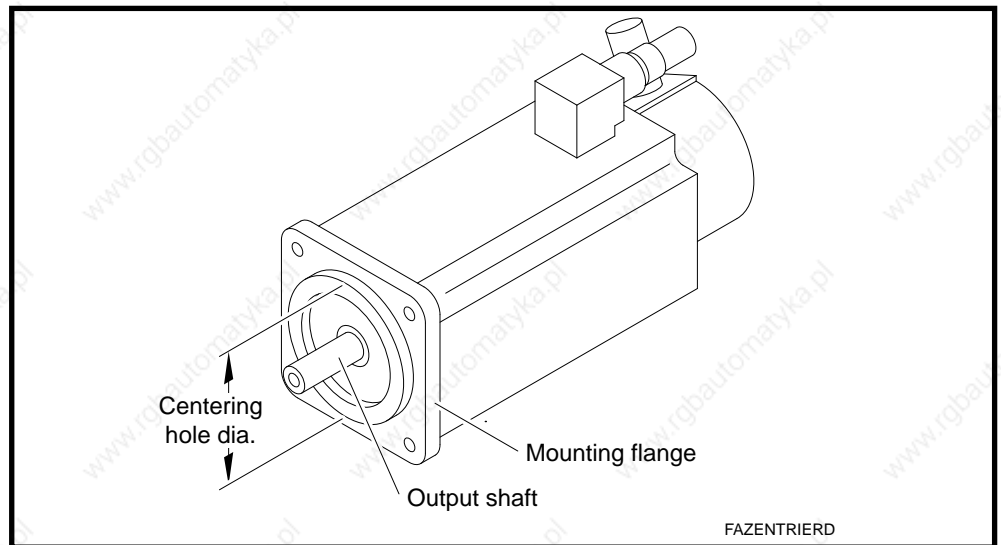

Fig. 2.7: Defining the term pilot /centering diameter

motor series	Pilot diameter in mm	
	Standard types	Customized types
MDD 021	32	—
MDD 025	40	—
MDD 041	50	—
MDD 065	95	—
MDD 071	95	—
MDD 090	110	130
MDD 093	110	130
MDD 112	130	180
MDD 115	130	180

Fig. 2.8: Pilot diameters for the individual motor series

Output shaft The design of the output shaft can be selected by the user. INDRAMAT recommends the use of plain output shafts.

Plain output shaft

A backlash-free and non-positive transmission of the torque can be achieved with a plain shaft. Clamping sets, pressure sleeves or similar clamping components can be used for coupling pinions, belt pulleys or similar elements.

Output shaft with keyway

This achieves a form-fitting torque transmission. This type of shaft-hub connection is suitable for lesser demands. A multi-axial stress state occurs at the shaft-hub connection as a result of torsion, bending, radial and axial loads. It is possible, during powerful reverse operations, for the bottom of the key to turn out and reduce the quality of concentricity. Ever-increasing defor-

mations can cause fractures. The use of plain shaft ends with non positive connections is therefore recommended.

Shaft sealing The shaft sealing is attached to the output shaft. It ensures that no liquids can penetrate into the motor housing along the shaft. An output shaft with shaft sealing is required for those applications where dirt or the affects of a jet of water can be present. The protetion category in this case is IP 65.

From motor series MDD 065 upwards, the output shafts are standardly equipped with a shaft sealing.

The output shaft of the MDD 021 is only available without a shaft sealing. The protection category in this case is IP 50. This means that this motor type is not suited for any applications where dirt or a jet of water are a factor.

The MDD 025 and MDD 041 offer the option of a design with or without a shaft sealing.

Permissible shaft load A load is being applied to the shaft as soon as radial or axial forces affect the motor shaft.

The **permissible radial force** (radial shaft load) is depicted in a diagram in section "Shaft Load Capacity" (Section 3.3., 4.3 and so on).

The permissible radial force depends on

- the average speed and
- the point of application of force.

The **permissible axial force** (axial shaft load) can be calculated with the aid of a formula, which can be found in this section.

Thermal Deformations



Thermal deformations in length affect side A of the motor. This means that the A side of the motor shaft end can shift up to 0.6 mm with respect to the motor housing. As a result, there is

- **a shifting of position by using drive pinions with helical teeth mounted to the motor output shaft but not axially fixed to the machine or**
- **occurring thermal stress by using drive pinions with helical teeth axially fixed to the machine and with bevel gear pinions. The latter can lead to damage on the bearing of side B of the motor.**

Cooling For extreme loads, as it is, for example, the case with continuous start-stop operations with a high level of repetitive frequency, it is possible to mount a surface-cooling unit to some of the motors.

Blower motors operating with 1 x AC 230 V and AC 115 V from the supply voltage are available.

The blower unit represents a separate component and can only be ordered with the use of its own order number. When ordered, the surface-cooling unit is delivered by INDRAMAT mounted to the motors and ready to connect.

Additional information about the blower units can be found in the documentation entitled "Blowers for mounting to MDD servo motors", doc. no.: 9.578.003.4.

Two possible types of surface cooling are available:

- axial and
- radial surface cooling.

Axial surface cooling

Axial cooling is suited for those applications that need a slender form.

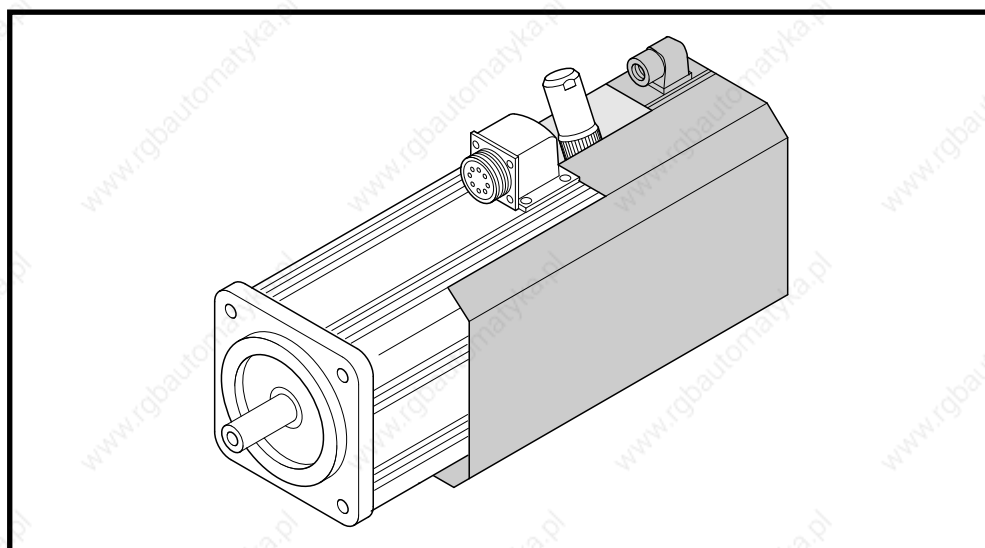

Fig. 2.9: An example of an MDD servo motor with axial surface cooling

Radial surface cooling

Radial cooling is suited for those applications that need a short construction.

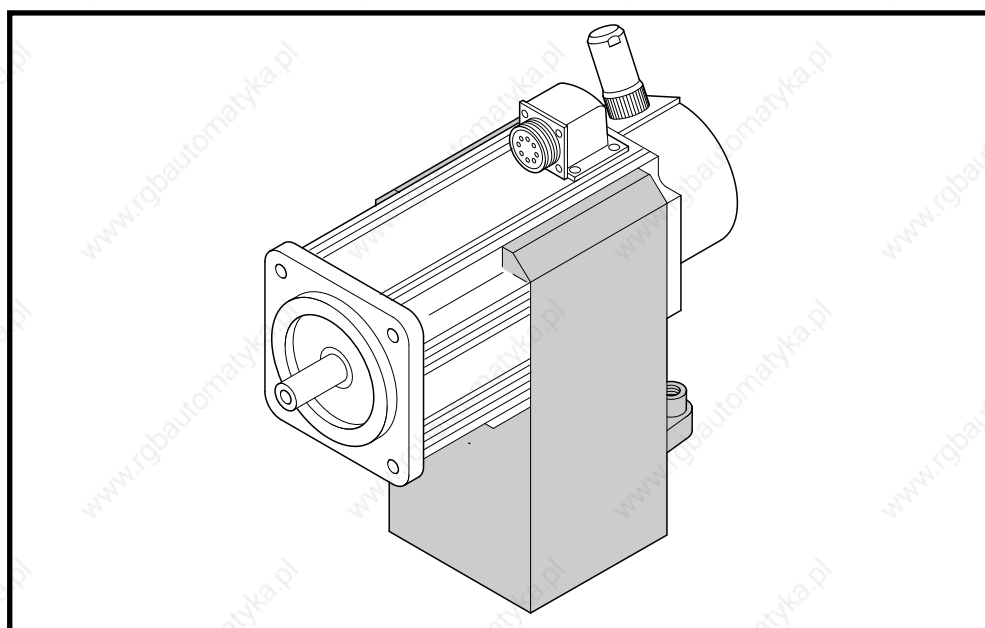

Fig. 2.10: An example of an MDD servo motor with radial surface cooling

The blower options for the individual motor series are listed in the table in Figure 2.11.

Motor type	Blower for surface cooling	
	axial	radial
MDD 021	—	—
MDD 025	—	—
MDD 041	—	—
MDD 065	+ ¹⁾	—
MDD 071	+ ¹⁾	+ ¹⁾
MDD 090	+	+ ¹⁾
MDD 093	+	+
MDD 112	+	+
MDD 115	+	+

— not available +available ¹⁾not available for motor length "A"

Fig. 2.11: Blower options

Blocking brake For a backlash-free holding of the servo axes when the machine is powered off, it is possible to equip them with a blocking brake.

The blocking brake, especially developed for these motors, works along the closed-circuit principle. At zero current, a magnetic force acts on the brake armature disc. This means that the brake is locked and holding off the axis. With the application of 24V DC, the electrical field cancels the permanent magnetic field and the brake opens.

The intelligent digital drive controller activates the blocking brake. This maintains the on and off switching sequence in all operating states. Current measurements in the drive monitor the release of the brake. The moment of clamping for an E-stop or fault situation can be selected via parameters to suit the application:

- immediate clamping
- clamping after speeds falls below 10 rpm or
- clamping after 400 ms, even with speeds greater than 10 rpm.



The blocking brake alone cannot guarantee the safety of personnel as it can fail or wear down. Additional measures must be taken to ensure personnel safety. These must be undertaken by the manufacturer of the machine and can, for example, be the mounting of a second brake.



The blocking brake is not a service brake. It wears down after approximately 20,000 revolutions against the closed brake.

With some motor types, the blocking brake is available with varying holding torques. With motors MDD 025 and MDD 041, the nominal torque M_{dN} drops somewhat if the motor is equipped with a blocking brake. Notes on this can be found in the section "Technical Data" of the respective motor series.



If the motor is stored for a period exceeding two years, then it is necessary to re-seat it before using.

To re-seat:

1. Run the motor at a speed of approximately 100 rpm.
2. Close the blocking brake and keep it closed for approximately 60 seconds.

Note: Open the line connection of the blocking brake to the controller.

3. Shut down the drive after 60 seconds.
4. Reconnect blocking brake to drive.

Balance class The MDD motors are dynamically balanced as per the balance class specified in DIN VDE 0530, section 14 (2/93 edition).

The user can select either one of two possible balance classes for the MDD 112 and MDD 115 depending upon the conditions of application of the motor

- balance class N (normal) for normal applications
- balance class R (reduced)
 - for more demanding applications, e.g., in grinding machines
 - for servo motors in main spindle applications, e.g., power tools in tool turrets of tool machines.

MDD 021, MDD 025 and MDD 040 motors are **only** balanced in terms of balance class N.

MDD 065, MDD 071, MDD 090 and MDD 093 motors are **always** balanced in terms of balance class R (reduced).

The balance class only applies to the pure motor and does not apply to the motor with components mounted on side A of the shaft end. The motors are balanced with the entire key in the case of output shafts with keyway.

Power connection The user must select the output direction of the power connection at the time the order is placed. This direction must correspond to the conditions at the machine. The output direction cannot be changed after delivery.

The following variants are available (see Figure 2.12):

- connector to side A
- connector to side B
- connector to the right
- connector to the left

Restrictions:

MDD 021 and MDD 041 are only available with side A or B output directions.

A variant with connecting cable and coupling unit in lieu of the connector housing is also available with the MDD 025 series. See the dimensions of the MDD 025.

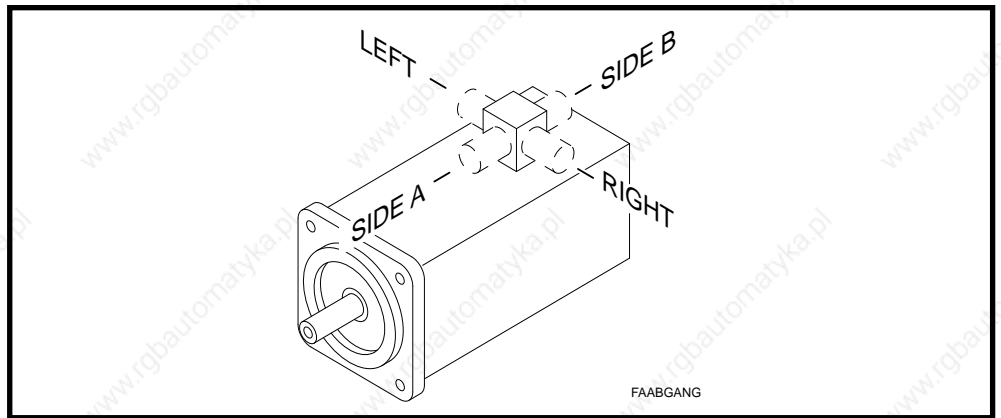

Fig. 2.12: Possible output directions of the power connections

Feedback connector Different types of connectors can be selected for connecting the motor feedback cable depending upon the installation conditions. Available are:

- straight connector
- angle connector

Information about the allocation of the connector type to the motor type can be found in the dimensional data sheets and in section 13.2 "Connector for the Feedback Connections".

Straight Connector

Figure 2.13 depicts a motor with a straight feedback connector.

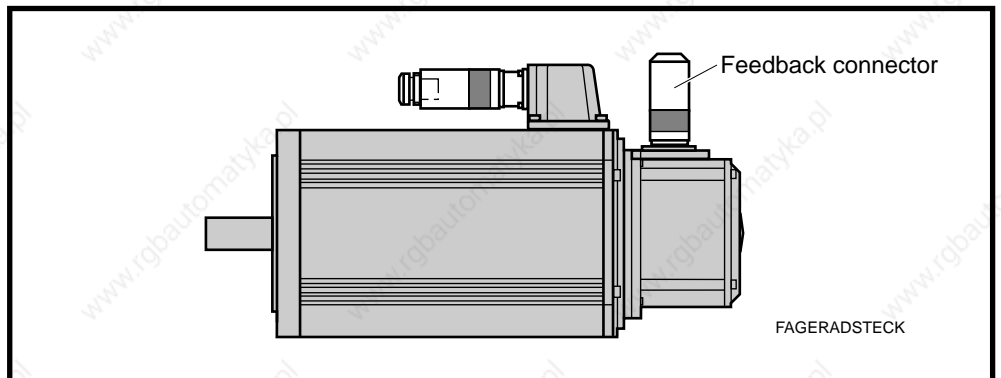

Fig. 2.13: MDD motor with straight feedback connector

Angle connector

INDRAMAT supplies and delivers the angle connectors so that the output direction of the cable, once inserted into the flanged socket, is side B of the motor.

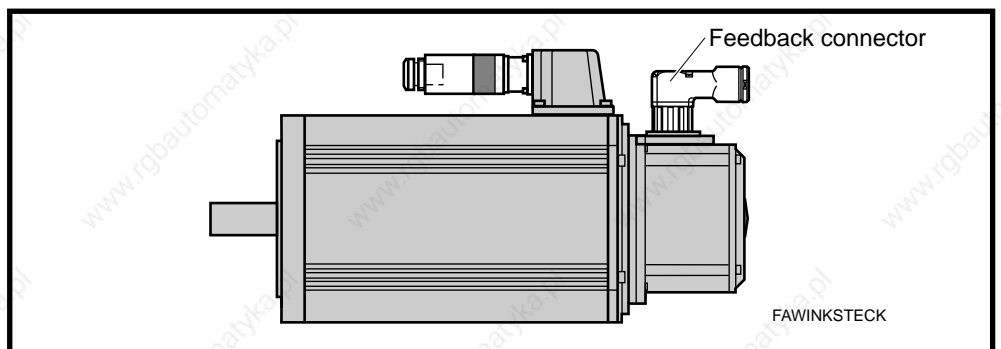

Fig. 2.14: MDD motor with angle connector (output direction at delivery is side B)

The user can change the output direction. Just release the four fixing screws (see Figure 2.15). The connector part can now be turned in increments of 90° into the position desired.



Make sure that neither the gasket nor the cable cores of the cable are damaged when re-tightening the screws.

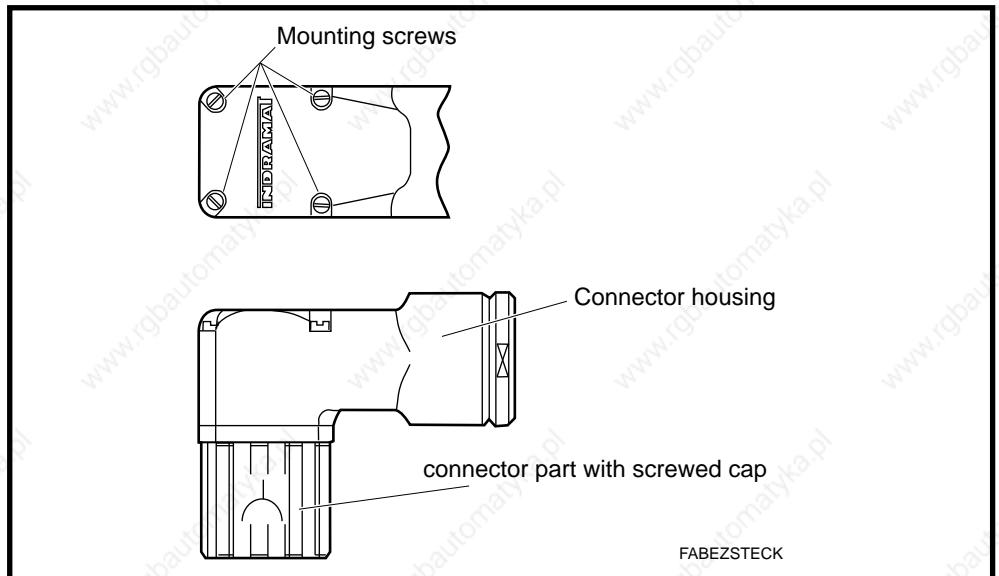

Fig. 2.15: Labelling the parts of the connector

2.3. Electrical Features

Terminal diagram

The terminal diagram shown in Figure 2.16 is purely schematic. It represents a checklist of all the necessary electrical connections to operate the MDD AC servo motor.

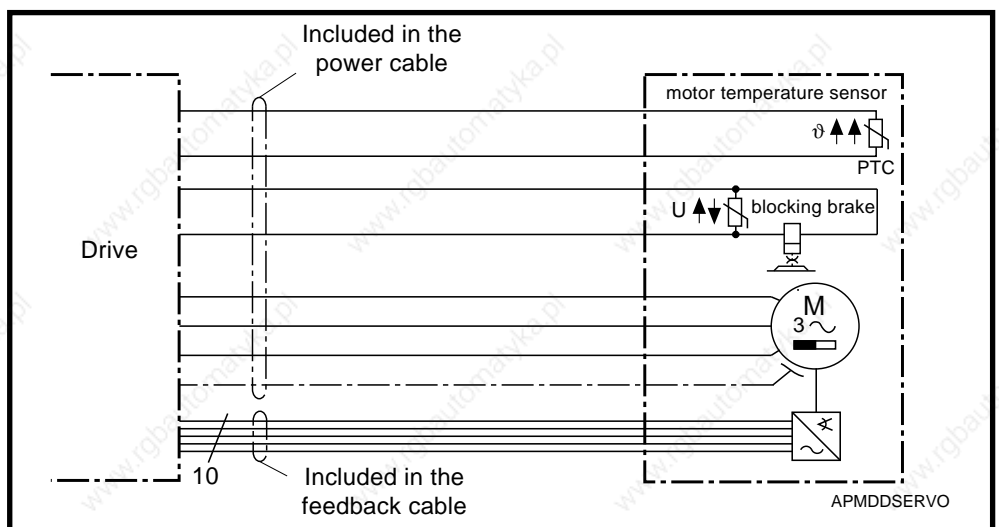

Fig. 2.16: Schematic terminal diagram

The following electrical connections are on the MDD motor:

- power connection
- feedback connection

If a blower for surface cooling is mounted on the motor, then a motor blower connection is also present. This is not shown in the terminal diagram.

The electrical connections of INDRAMAT drives have been standardized to minimize cable diversity. Sections 12 and 13 specify the electrical connections for a given application and motor type.

Power connection The following connections are integrated into the power connection:

- power cable
- connecting cable for temperature sensor (PTC)
- connecting cable for blocking brake

The temperature sensor is built into the windings of the motor. The motor is protected against overheating by evaluating the temperature sensor in the controller. In the case of a motor shutdown for thermal reasons, the controller will generate the appropriate error message.

The blocking brake is controlled by the drive controller.

Motor power connectors for the electrical power connections are available either

- for crimping or
- soldering.

Power cables with metric cable diameters can be either crimped or soldered to the motor power connector. Power cables with inch diameters can only be soldered.

Feedback connection There is a 12-pin flanged socket on the motor for the feedback connection.

The connection diagram, available feedback cables and feedback connectors are all outlined in section 13.

Motor blower connection The motor blower is connected via a protective motor switch. This means it operates independently of the controller.

Additional information about the motor blower can be found in the document "Blowers for mounting to MDD servo motors", doc. no. 9.578.003.4.

2.4. Motor feedback

Versions The motors are equipped with a motor feedback for the evaluation of position and speed and for the detection of rotor position. It is available with either

- relative or
- absolute position detection.

Depending on the motor series, the motor feedback is either a "resolver feedback" or a "digital servo feedback". Figure 2.17 shows the allocation of version to motor type.

Measuring principle		Inductive System		Optical System	
		relative	absolute	relative	absolute
Position detection		relative	absolute	relative	absolute
Version		Resolver feedback (RSF)	Resolver feedback with integrated pulse wire absolute encoder (RSF + IDG)	Digital servo feedback (DSF)	Digital servo feedback with integrated multi-turn absolute encoder (DSF + MTG)
Line of motors MDD...	021	X	X		
	025	X	X		
	041	X	X		
	065			X	X
	071			X	X
	090			X	X
	093			X	X
	112			X	X
	115			X	X

Fig. 2.17: Possible versions of the motor feedback and allocation to line of motor

The versions "DSF" and "DSF + MTG" have the same dimensions. The dimensions of the versions "RSF" and "RSF + IDG" are also identical.

Motor feedback with relative position detection (DSF or RSF)

This version permits a **relative indirect position evaluation** of position on the motor. The relative position is stored in the intelligent digital drive. It can be handed over to the NC master control. This eliminates the need for separate incremental encoders on the motor. The absolute position of the axis is lost when power is shut down. Powering up requires renewed homing.

This version is also used with **relative direct position detection** on the machine.

Motor feedback with absolute position detection (DSF + MTG or RSF + IDG)

This version permits an **absolute indirect position detection** on the motor. The absolute position is stored in the intelligent digital drive and can be handed over to the NC master control. This eliminates the need for a separate absolute encoder on the motor. The absolute position of the axis is maintained when power is shut off.

This version is also used with **relative direct position detection** on the machine combined with absolute position detection on the motor

Feedback storage The motor feedback is equipped with data storage capacities in which the motor parameters are stored. After each powering up, the parameters are set in the drive. This guarantees that the drive can be operated without damaging the motor.

Technical Data

Digital Servo Feedback with/without Integrated Multiturn Absolute Encoder	
Features	Data
Measuring principle	Optical System
Position resolution on the motor	$256 \times 2^{13} = 2\,097\,152$ increments/revolutions
System accuracy	± 0.5 angular minutes
Detection range with absolute position detection	4096 motor revolutions

Fig. 2.18: "Digital servo feedback" - technical data

Resolver Feedback with/without integrated Absolute Pulse Encoder	
Features	Data
Measuring principle	Inductive System
Position resolution on the motor	$2 \times 2^{13} = 16\,384$ increments/revolutions
System accuracy	± 7 angular minutes
Detection range with absolute position detection	4096 motor revolutions

Fig. 2.19: "Resolver feedback" - technical data

2.5. Torque-Speed Characteristics

This section contains explanations about the torque-speed characteristics. These are depicted for each type of motor in sections 3.2, 4.2 through to 11.2.

The curves of some of the motors may deviate from the features described here. These deviations are, however, then relevantly documented.

What is depicted The operating curves depict:

- the torque limiting data,
- the speed limiting data and
- the operating curves.

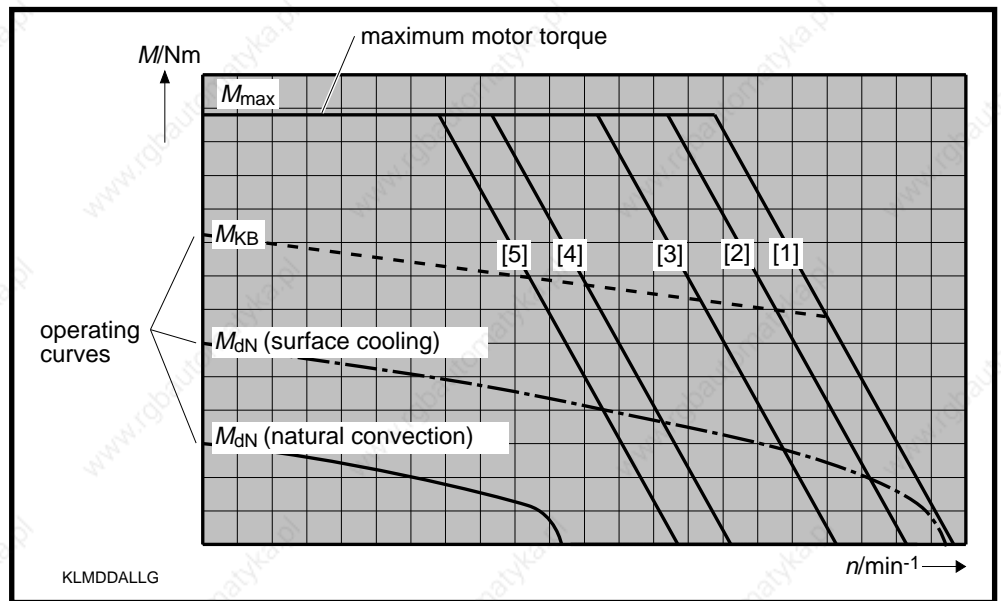

Fig. 2.20: The torque-speed characteristics curves illustrated

Usage The torque-speed characteristics curves can be used:

- to record information from the selection documentation
- to determine the possible maximum usable speed for a special application with known torque requirements, and
- to check whether the application remains within the thermal limits of the motor. The effective torque for a critical cycle must be below the S1 continuous operating characteristics curve of the arithmetically averaged speed.

Limiting value for torque

The horizontal line M_{max} depicts the theoretically possible maximum torque of the motor. The drive can limit this maximum torque resulting from the various motor-controller combinations. It is outlined in the selection documentation.

Limiting value for speed

Maximum motor speed is determined by the DC bus voltage produced by the supply source at the drive. Depending upon the DC bus voltage at the drive, maximum torque drops at a breaking point.

DC bus with a regulated power supply

In the case of those supply modules with a regulated power supply, the power data of the drive-motor combination are not dependent on the fluctuations of the mains voltage.

DC bus voltage with an unregulated power supply

In the case of those supply modules with an unregulated power supply, the power data of the drive-motor combination are dependent on the fluctuations of the mains voltage. Varying power data are achieved under the following conditions at the mains:

- 10 % overvoltage
- nominal voltage
- 10 % undervoltage

The declining lines are numbered. The following allocations apply:

- [1] -DC bus voltage with a regulated power supply (e.g., KDV 4, TVD, KVR and TVR) or an unregulated power supply (e.g., TVM 2, KDV 1, KDV 2, KDV 3 and DKS) if AC mains input voltage is 10% higher than the rated 3 x 230 volts AC.
- [2] - DC bus voltage with an unregulated power supply connected to three-phase mains rated at 3 x 230 volts AC (e.g., TVM 2, KDV 1, KDV 2, KDV 3 and DKS).
- [3] - DC bus voltage with an unregulated power supply connected to three-phase mains rated at 3 x 230 volts AC with 10% undervoltage (e.g., TVM 2, KDV 1, KDV 2, KDV 3 and DKS).
- [4] - DC bus voltage with an unregulated power supply (e.g., DKS) if AC mains voltage is connected to a single phase mains with 1 x 230 volts AC.
- [5] - DC bus voltage with an unregulated supply (e.g., DK) if the AC mains input voltage is 10% less than the rated 1 x 230 volts AC.

Operating curves The operating curves depict the permissible continuous torque (operating mode S1) and the intermittent duty torque (operating mode S6 as per DIN 57530/VDE 0530, 07/91 edition).

The following allocations apply:

- S1-continuous operating curve of the motor with "natural convection"
- - - - - S1-continuous operating curve of a surface-cooled motor
- - - - - S6-intermittent operating curve:
at 25% ON time of a motor with natural convection, or the duration depicted in the curves for a surface-cooled motor. Maximum duty cycle time is depicted in Figure 2.21.

MDD ... line of motors	Maximum Duty Cycle Time
021, 025, 041	5 minutes
065, 071, 090, 093, 112, 115	15 minutes

Fig. 2.21: Maximum duty cycle time with intermittent operations

3. MDD 021

3.1. Technical Data

Designation	Symbol	Unit	Motor type MDD ...	
			021 A-N-100	021 B-N-100
Nominal motor speed ¹⁾	n	min ⁻¹	10000	10000
Cont. torque at standstill ²⁾	M_{dN}	Nm	0.15	0.30
Cont. current at standstill	I_{dN}	A	0.8	1.6
Theor. maximum torque ³⁾	M_{max}	Nm	0.64	1.3
Peak current	I_{max}	A	3.6	7.1
Moment of inertia of rotor	J_M	kgm ²	0.22 x 10 ⁻⁴	0.31 x 10 ⁻⁴
Torque constant at 20 °C	K_m	Nm/A	0.19	0.19
Windings resistance at 20 °C	R_A	Ohm	18	6.8
Windings inductance	L_A	mH	9.5	4.5
Thermal time constant	T_{th}	min	15	15
Mass	m_M	kg	1.0	1.3

¹⁾ Usable motor speed is determined by the torque requirements of the application. The usable speed n_{max} found in the selection lists of the motor-drive combinations are binding for **standard applications**. The usable speed for other applications can be found using the required torque in the torque-speed characteristics curve.
²⁾ With 60K overtemperature at the motor housing.
³⁾ Achievable maximum torque is dependent upon the drive used. **Only** those maximum torques M_{max} found in the selection list of the motor-drive combinations are binding.

Fig 3.1: Type dependent motor data

Designation	Symbol	Unit	Data
Permissible ambient temperature	T_{um}	°C	0 ... + 45
Permissible storage and transport temperatures	T_L	°C	-20 ... + 80
Maximum installation elevation		m	1000 meters above sea level
Protection category			IP 65 ¹⁾
Insulation classification			F
Housing finish			Black prime coat (RAL 9005)

¹⁾ Does not apply to the output shaft. Its protection category is IP 50.

Fig 3.2: General data - MDD 021

3.2. Torque-Speed Characteristics

MDD 021 A at
10000 min⁻¹

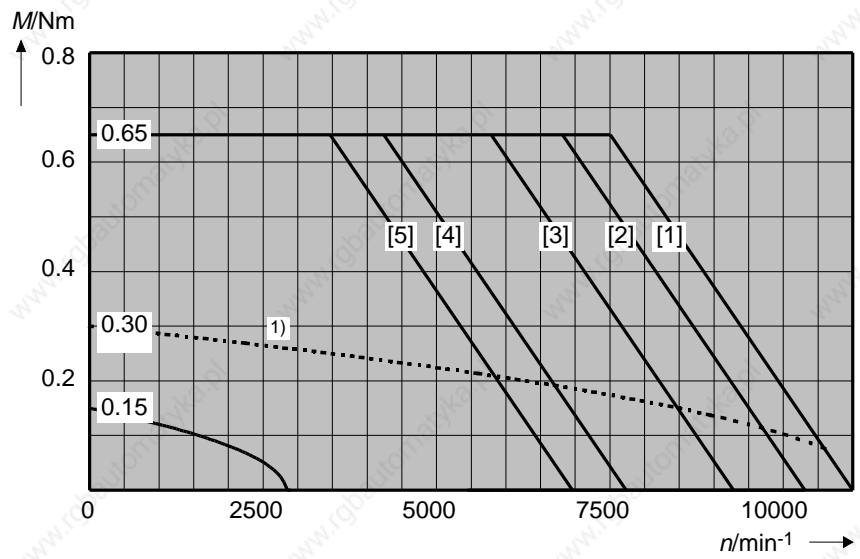

MDD 021 B at
10000 min⁻¹

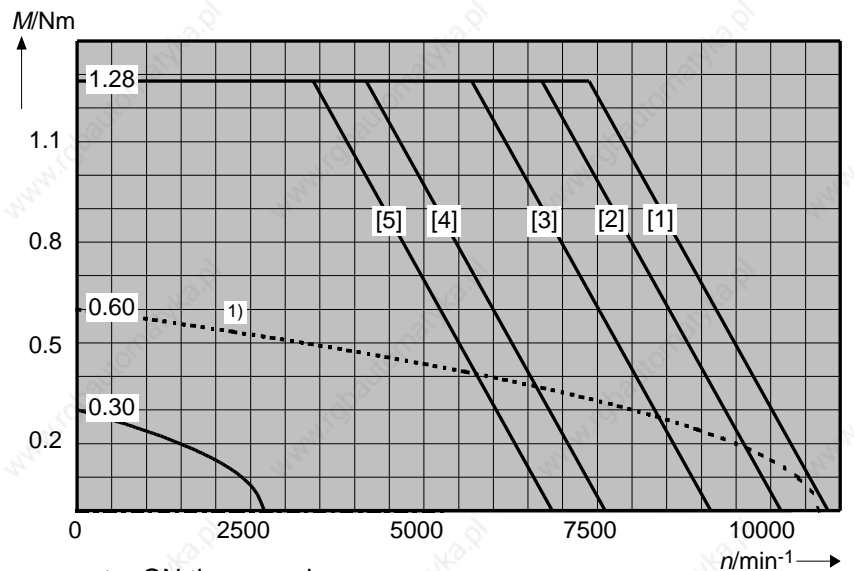

1) Shown: motor ON time equals 25%.
Maximum duty time equals five minutes.

Fig 3.3: Torque-speed characteristics curves - MDD 021

3.3. Shaft Load Capacity

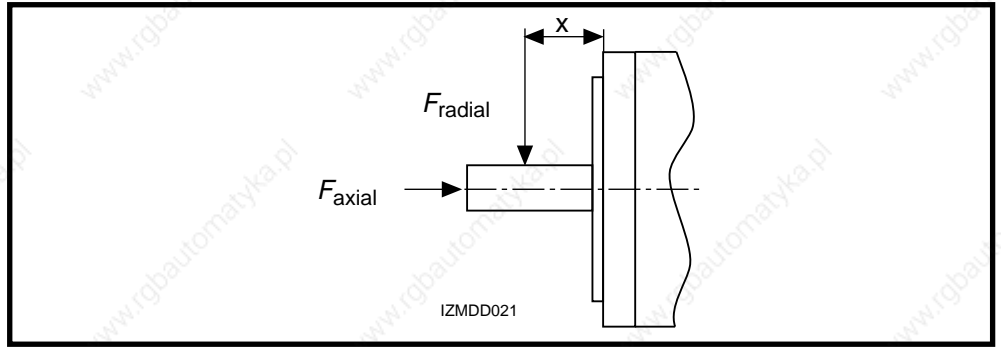

Fig 3.4: Shaft load

Permissible radial force
 F_{radial}

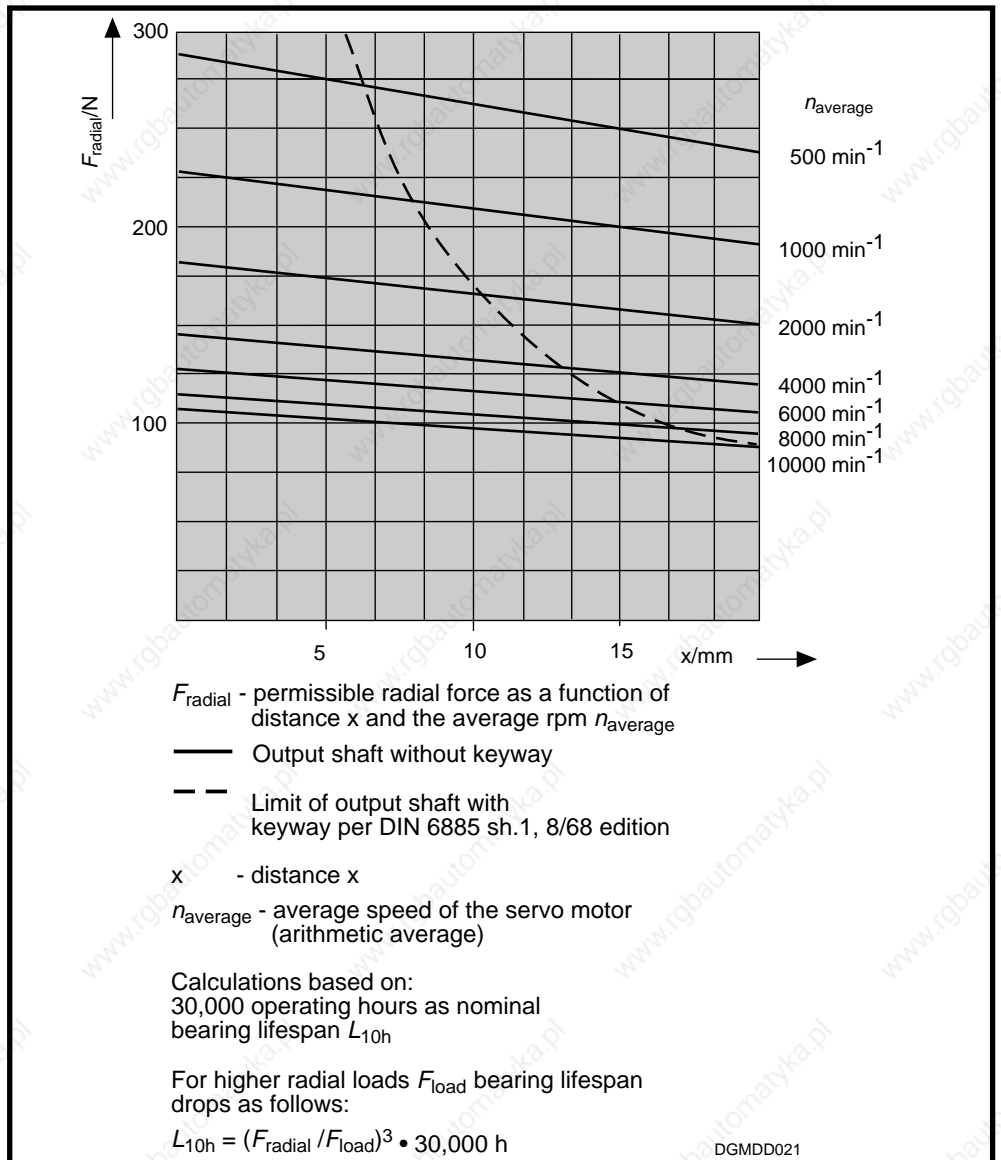

Fig 3.5: Permissible radial force

Permissible axial force
 F_{axial}

$$F_{axial} = 0.60 \cdot F_{radial}$$

F_{axial} - permissible axial force
 F_{radial} - permissible radial force

3.4. Dimensional Data

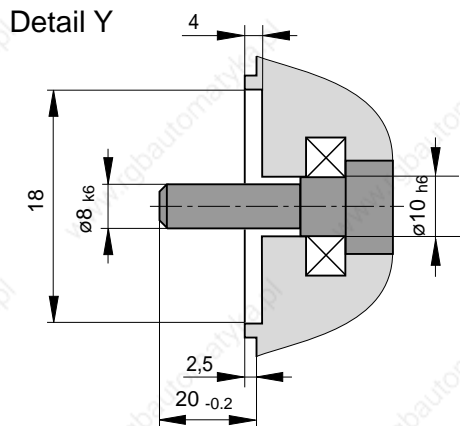
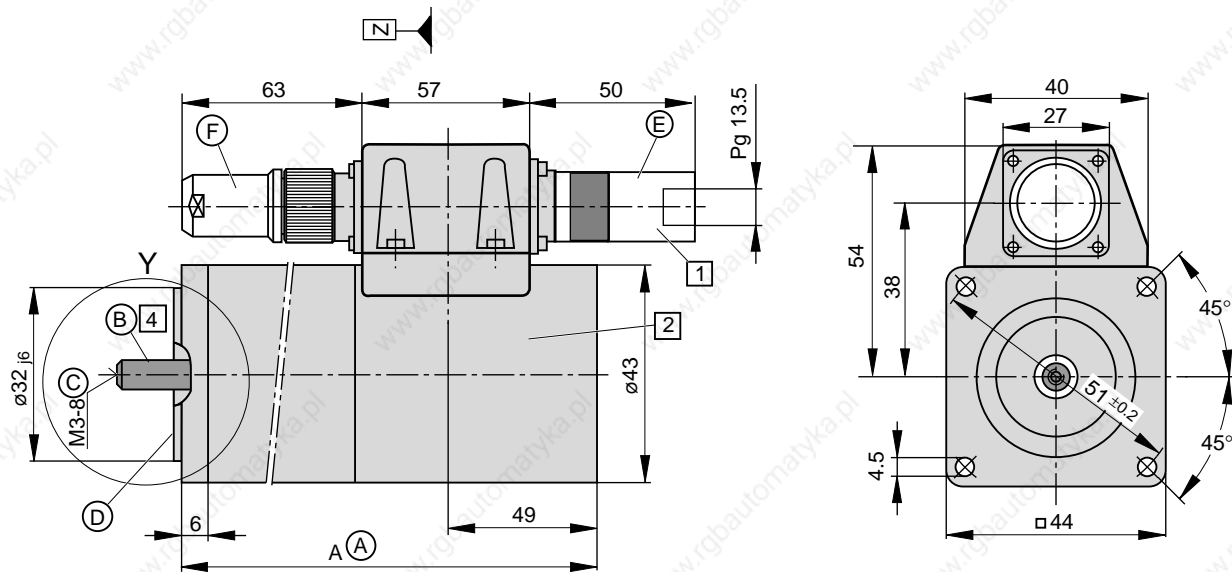

(A) Dimensional table Dim. A

Size	Dim. A
MDD 021 A	173
MDD 021 B	213

(B) Concentricity, excentricity and coaxiality to the shaft per DIN 42955, tolerance class R, 12/81 edition.

- (C) • Shaft end per DIN 748 section 3, 7/75 edition, IEC 72, 1971 edition, cylindrical
 • Center hole DS M3-8 per DIN 332 section 2, 5/83 edition
 • Max. tightening torque M_A for screws in the threads of the center hole: 0.5 Nm
 • Balance class N per DIN VDE 0530 section 14, 2/93 edition

(D) Flange type per DIN 42948, 11/65 edition, makes mounting possible
 • as per design B5 (throughholes in flange)
 • as per design B14 (threads in flange)

(E) **Motor power connector**
 INS 252 must be ordered separately.

(F) **Feedback connector:**
 INS 513 and INS 512 must be ordered separately as possible types.

MBMDD021_1

Fig 3.6: Dimensional data - MDD 021

Available Options

1 Power connection

The output direction of the electrical power connector is selected at the time the order is placed. Possible output direction is either:

- side A or
- side B

The drawing depicts side B as output direction. The dimensions of any other output direction are obtained by virtually turning the connector housing around the Z axis.

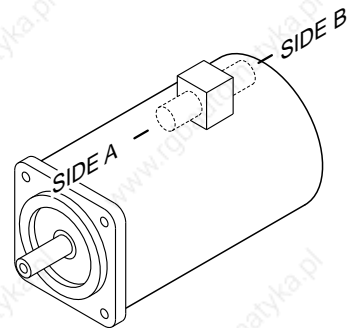

2 Motor feedback

- Resolver feedback
 - Resolver feedback with integrated pulse wire absolute encoder
- The dimensions are identical.

4 Output shaft

- plain shaft (preferred type)
- with keyway per DIN 6885 sheet 1, 8/68 edition
(Note: balanced with entire key!)

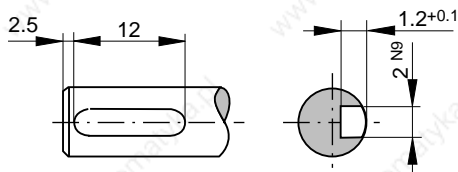

Matching key: DIN 6885-A 2 x 2 x 12

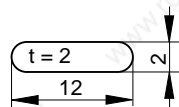

MBMDD021_2

Fig 3.7: Dimensional data - MDD 021 - selectable options

3.5. Available Versions

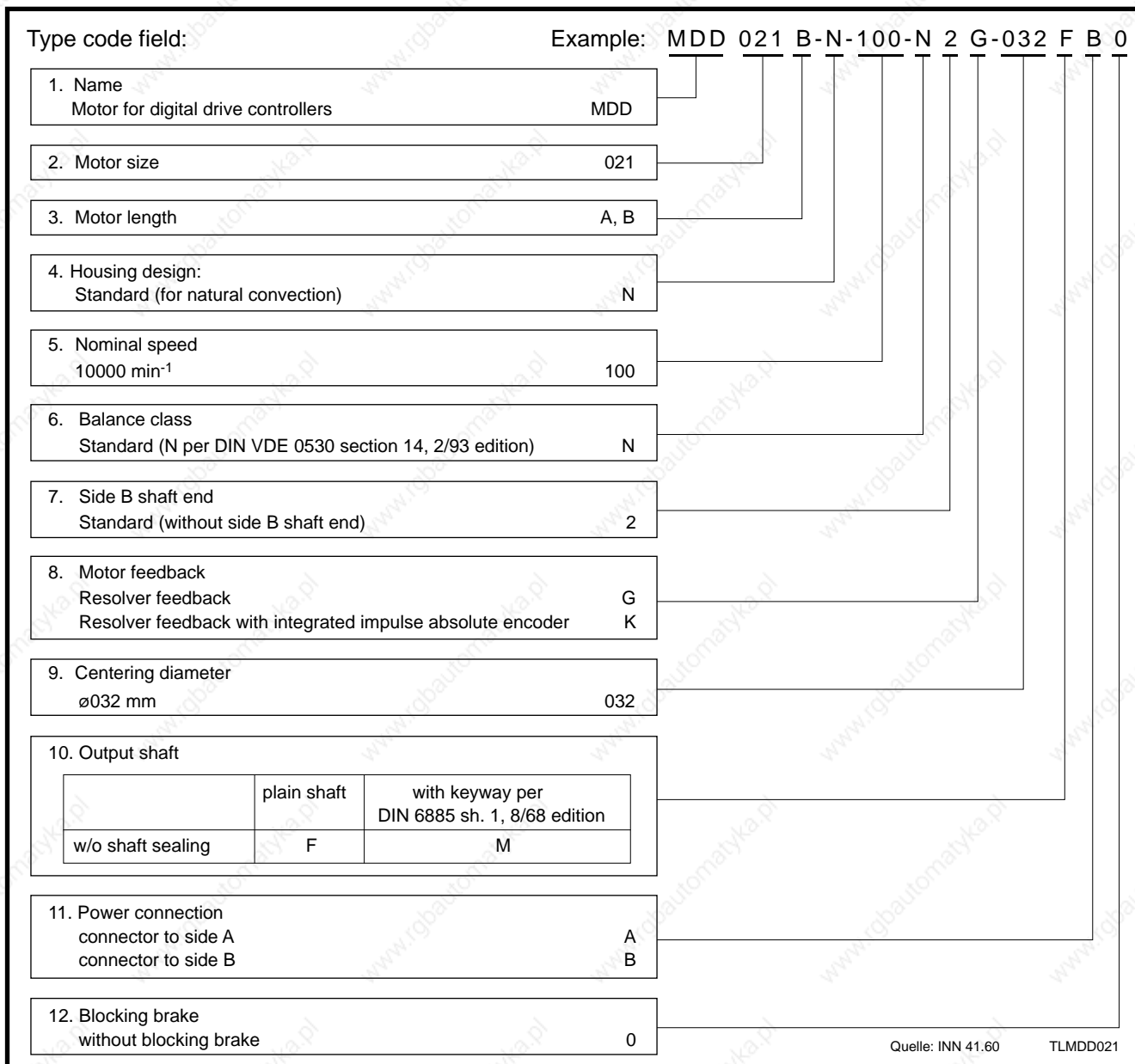

Fig 3.8: Type codes - MDD 021

Empty page

4. MDD 025

4.1. Technical Data

Designation	Symbol	Unit	Motor type MDD ...		
			025 A-N-100	025 B-N-100	025 C-N-100
Nominal motor speed ¹⁾	n	min ⁻¹	10000	10000	10000
Cont. torque at standstill ²⁾	M_{dN}	Nm	0.33 (0.27) ⁵⁾	0.60 (0.51) ⁵⁾	0.90 (0.75) ⁵⁾
Cont. current at standstill	I_{dN}	A	1.5	2.7	3.9
Theor. maximum torque ³⁾	M_{max}	Nm	1.,44	2.61	3.94
Peak current	I_{max}	A	6.8	12.3	17.6
Moment of inertia of rotor ⁴⁾	J_M	kgm ²	0.23×10^{-4}	0.32×10^{-4}	0.41×10^{-4}
Torque constant at 20 °C	K_m	Nm/A	0.22	0.22	0.23
Windings resistance at 20 °C	R_A	Ohm	7.5	2.75	1.8
Windings inductance	L_A	mH	9.7	4.8	3.5
Thermal time constant	T_{th}	min	15	15	15
Mass ⁴⁾	m_M	kg	1.5	2.0	2.5

¹⁾ Usable motor speed is determined by the torque requirements of the application. The usable speed n_{max} found in the selection lists of the motor-drive combinations are binding for **standard applications**. The usable speed for other applications can be found using the required torque in the torque-speed characteristics curve.
²⁾ With 60K overtemperature at the motor housing.
³⁾ Achievable maximum torque is dependent upon the drive used. **Only** those maximum torques M_{max} found in the selection list of the motor-drive combinations are binding.
⁴⁾ Without blocking brake.
⁵⁾ Parenthetical values apply to motors with blocking brake.

Fig 4.1: Type dependent motor data

Designation	Symbol	Unit	Data
Permissible ambient temperature	T_{um}	°C	0 ... + 45
Permissible storage and transport temperatures	T_L	°C	-20 ... + 80
Maximum installation elevation		m	1000 meters above sea level
Protection category			IP 65 ¹⁾
Insulation classification			F
Housing finish			Black prime coat (RAL 9005)

¹⁾Does not apply to the output shaft: Without shaft sealing protection category is IP 50.
 With shaft sealing protection category is IP 65.

Fig 4.2: General data - MDD 025

Designation	Symbol	Unit	Data Blocking Brake
Principle of action			electrically- actuated release
Holding torque	M_H	Nm	1.0
Nominal voltage	U_N	V	DC 24 ± 10%
Nominal current	I_N	A	0.4
Moment of inertia	J_B	kgm ²	0.08×10^{-4}
Release delay	t_L	ms	30
Clamping delay	t_K	ms	5
Mass	m_B	kg	0.25

Fig 4.3: Technical data - blocking brake

4.2. Torque-Speed Characteristics

The torque-speed characteristics of the MDD 025 line of motors deviates from those depicted in section 2.5.

Figure 4.4 illustrates that the operating curves are differentiated in terms of motors "with or without" blocking brakes and "with or without" shaft sealing.

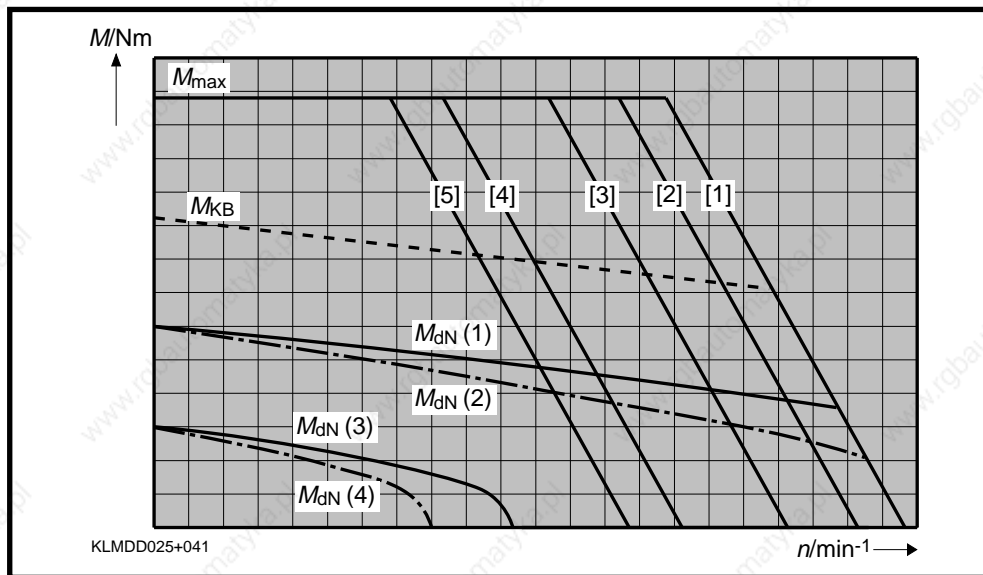

Fig 4.4: Schematic diagram of the torque-speed characteristics with MDD 025

Operating curves The operating curves represent the permissible continuous torque M_{dN} (operating mode S1) and intermittent torque M_{KB} (operating mode S6 as per DIN VDE 0530; status of 7/91).

The following allocations apply:

M_{dN} (1) S1-continuous operating curve of the motor without blocking brake / without shaft sealing

- · - · - M_{dN} (2) S1-continuous operating curve of the motor without blocking brake / with shaft sealing

M_{dN} (3) S1-continuous operating curve of the motor with blocking brake / without shaft sealing

- · - · - M_{dN} (4) S1-continuous operating curve of the motor with blocking brake / with shaft sealing

- - - - - S6-intermittent operating curve at 25 % ON time of the motor Maximum duty cycle time equals five minutes.

MDD 025 A at 10000 min⁻¹

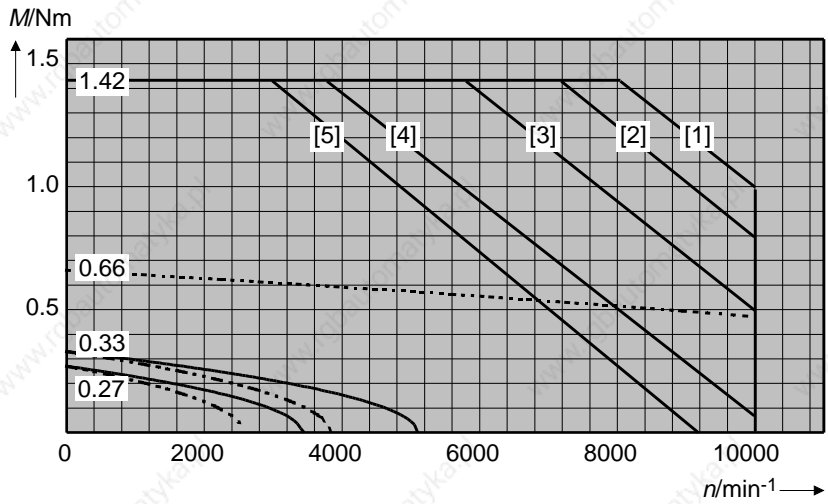

MDD 025 B at 10000 min⁻¹

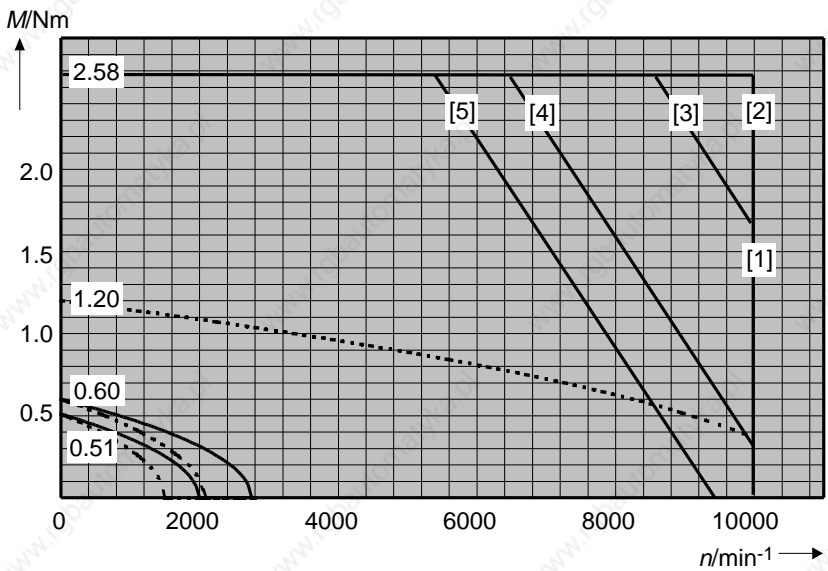

MDD 025 C at 10000 min⁻¹

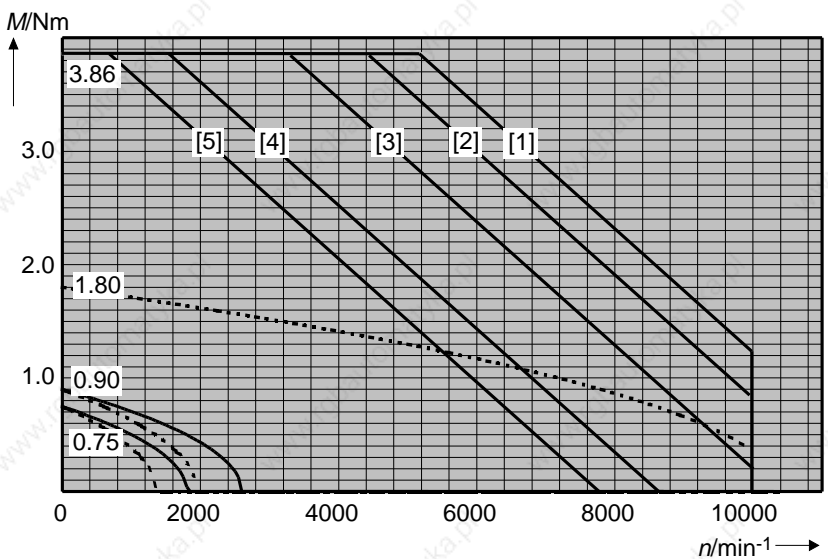

Fig 4.5: Torque-speed characteristics curves - MDD 025

4.3. Shaft Load Capacity

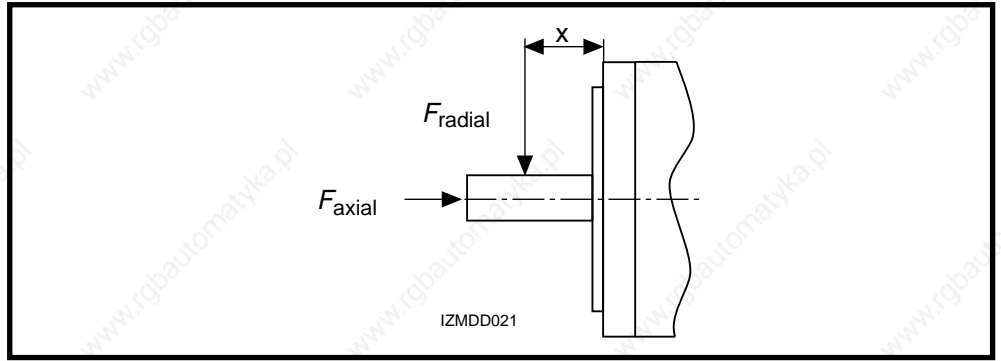

Fig 4.6: Shaft load

Permissible radial force

F_{radial}

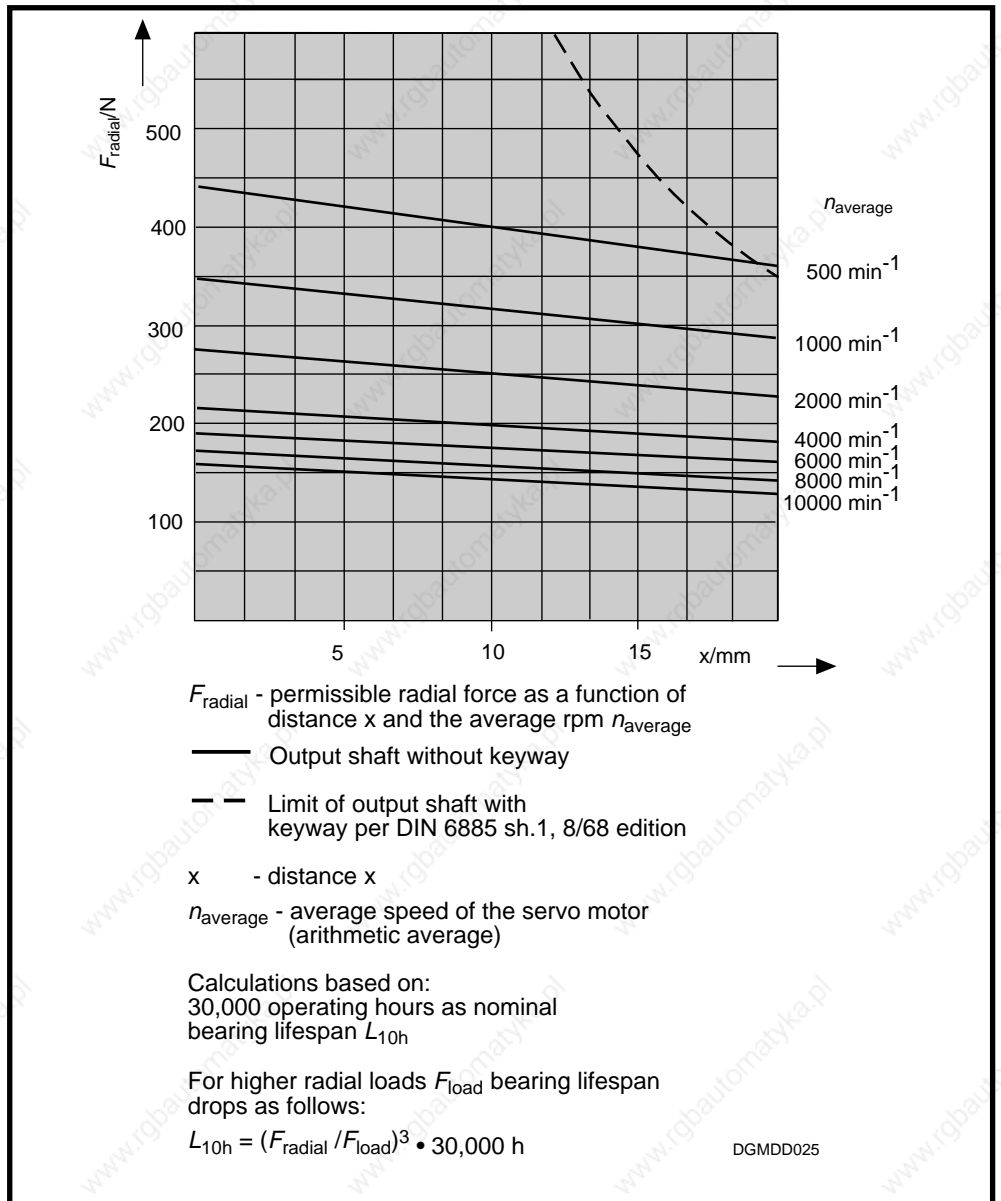

Fig 4.7: Permissible radial force

Permissible axial force

F_{axial}

$$F_{\text{axial}} = 0.55 \cdot F_{\text{radial}}$$

F_{axial} - permissible axial force

F_{radial} - permissible radial force

4.4. Dimensional Data

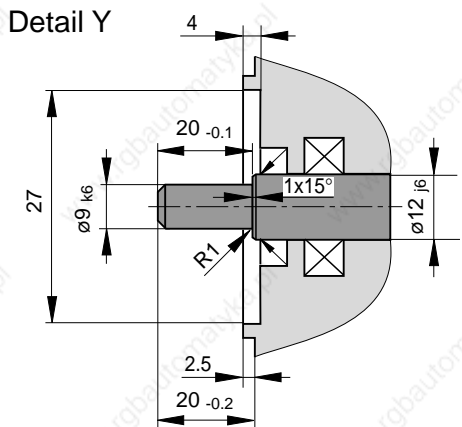
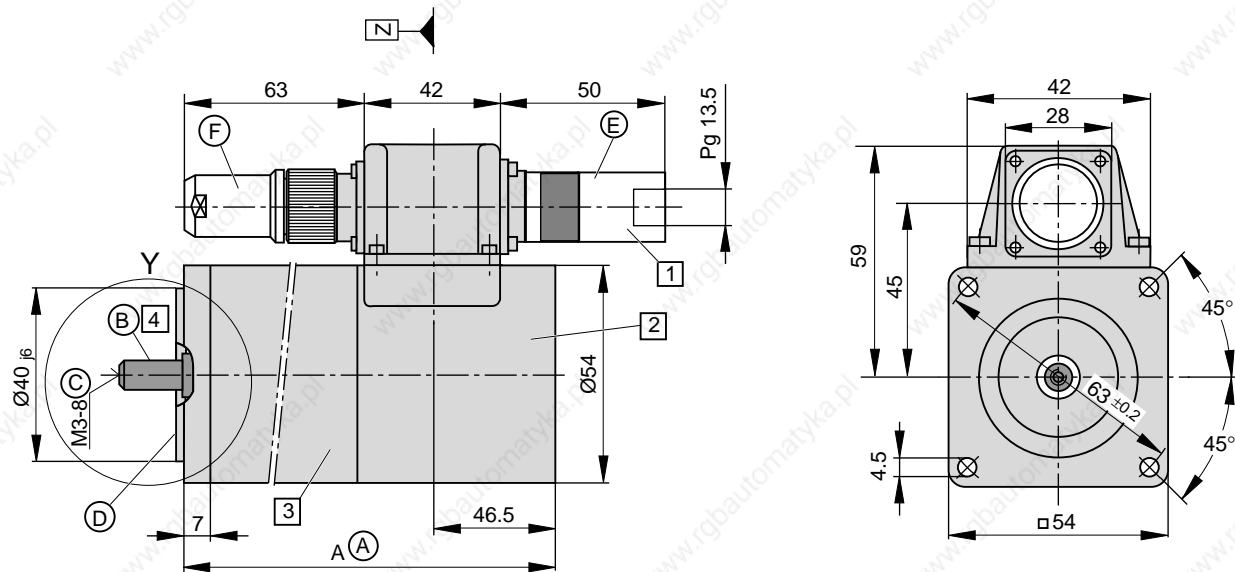

- Ⓒ • Shaft end per DIN 748 section 3, 7/75 edition, IEC 72, 1971 edition, cylindrical
- Center hole DS M3-8 per DIN 332 section 2, 5/83 edition
- Max. tightening torque M_A for screws in the threads of the center hole: 0.5 Nm
- Balance class N per DIN VDE 0530 section 14, 2/93 edition

Ⓐ **Dimensional table Dim. A**

Size	Dim. A 1)
MDD 025 A	182
MDD 025 B	219
MDD 025 C	257

1) Bigger with some options. The then applicable dimension is indicated under the respective feature.

- Ⓑ Concentricity, excentricity and coaxiality to the shaft per DIN 42955, tolerance class R, 12/81 edition.

- Ⓓ Flange type per DIN 42948, 11/65 edition, makes mounting possible
 - as per design B5 (throughholes in flange)
 - as per design B14 (threads in flange)

- Ⓔ **Motor power connector**
INS 252 must be ordered separately.

- Ⓕ **Feedback connector:**
INS 513 and INS 512 must be ordered separately as possible types.

MBMDD025_1

Fig 4.8: Dimensional data - MDD 025 (with flanged socket)

Available Options

1 Power connection

The output direction of the electrical power connector is selected at the time the order is placed. Possible output direction is either:

- side A or
- side B
- to the right
- to the left

The drawing depicts side B as output direction. The dimensions of any other output direction are obtained by virtually turning the connector housing around the Z axis.

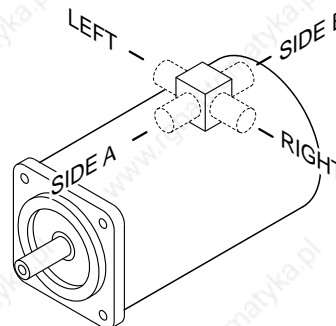

2 Motor feedback

- Resolver feedback
 - Resolver feedback with integrated pulse wire absolute encoder
- The dimensions are identical.

3 Blocking brake

- without blocking brake
- with blocking brake: 1.0 Nm

Dimensional table for motors with blocking brake

Size	Dim. A
MDD 025 A	207
MDD 025 B	244
MDD 025 C	282

4 Output shaft

- plain shaft (preferred type)
 - with keyway per DIN 6885 sheet 1, 8/68 edition
- (Note: balanced with entire key!)

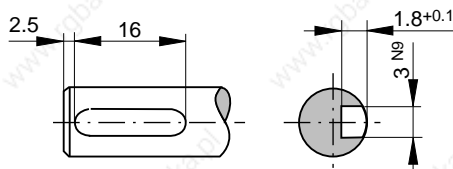

Matching key: DIN 6885-A 3 x 3 x 16

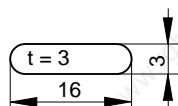

MBMDD025_2

Fig 4.9: Dimensional data MDD 025 (with flanged socket) - available options

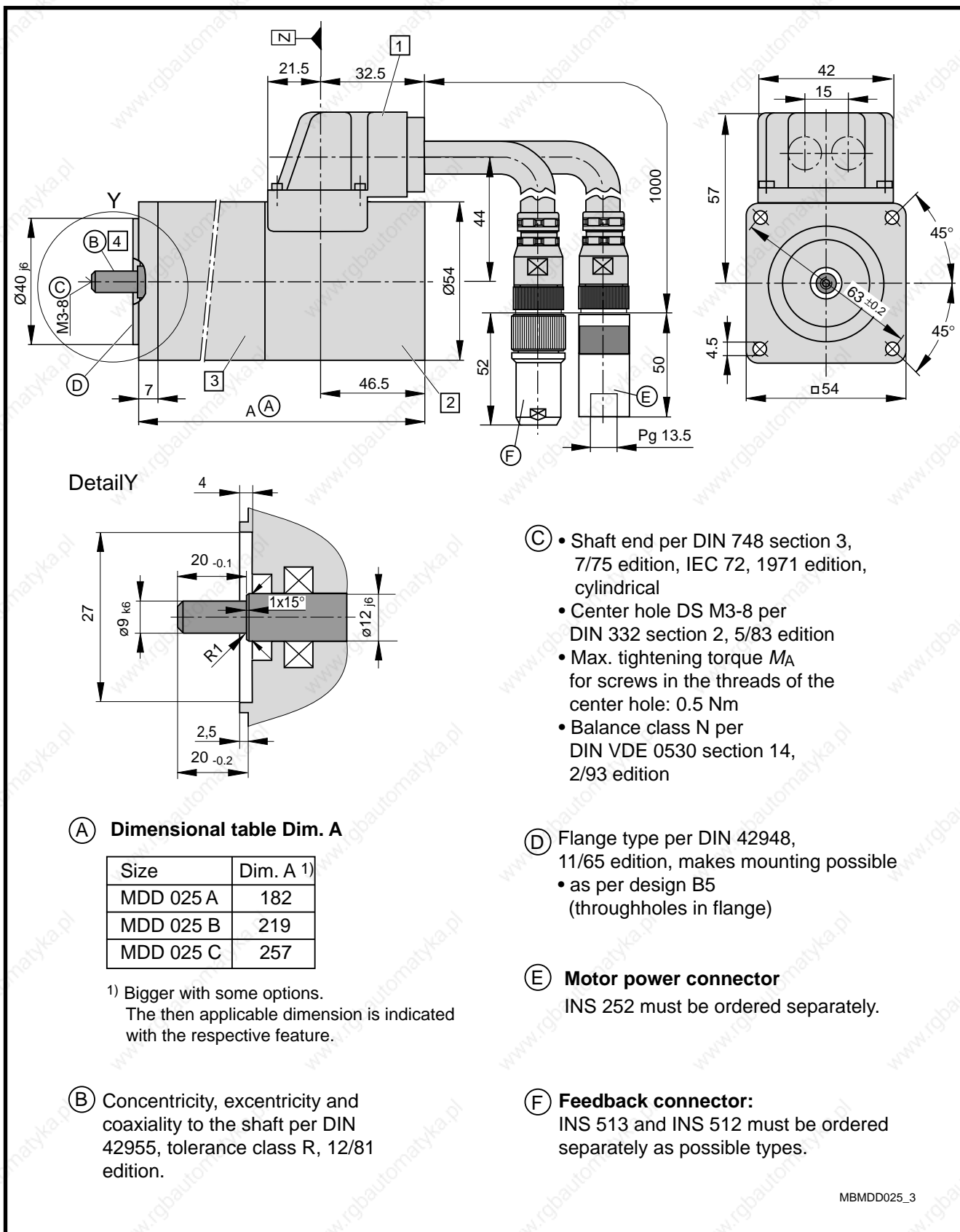

Fig 4.10: Dimensional data - MDD 025 (with connecting cable and coupling unit)

Available Options

1 Power connection

The output direction of the electrical power connector is selected at the time the order is placed. Possible output direction is either:

- side A or
- side B
- to the right
- to the left

The drawing depicts side B as output direction. The dimensions of any other output direction are obtained by virtually turning the connector housing around the Z axis.

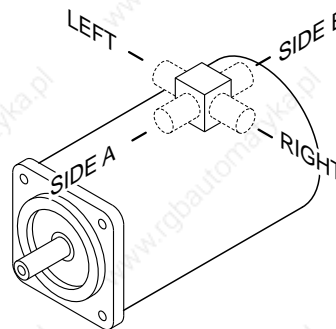

2 Motor feedback

- Resolver feedback
 - Resolver feedback with integrated pulse wire absolute encoder
- The dimensions are identical.

3 Blocking brake

- without blocking brake
- with blocking brake: 1.0 Nm

Dimensional table for motors with blocking brake

Size	Dim. A
MDD 025 A	207
MDD 025 B	244
MDD 025 C	282

4 Output shaft

- plain shaft (preferred type)
- with keyway per DIN 6885 sheet 1, 8/68 edition
(Note: balanced with entire key!)

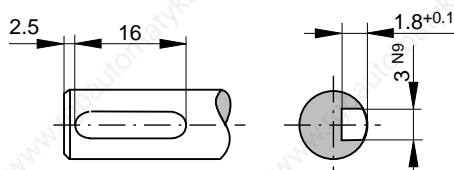

Matching key: DIN 6885-A 3 x 3 x 16

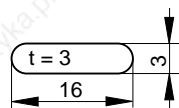

MBMDD025_2

Fig 4.11: Dimensional data - MDD 025 (with connecting cable and coupling unit)
- available options

4.5. Available Versions

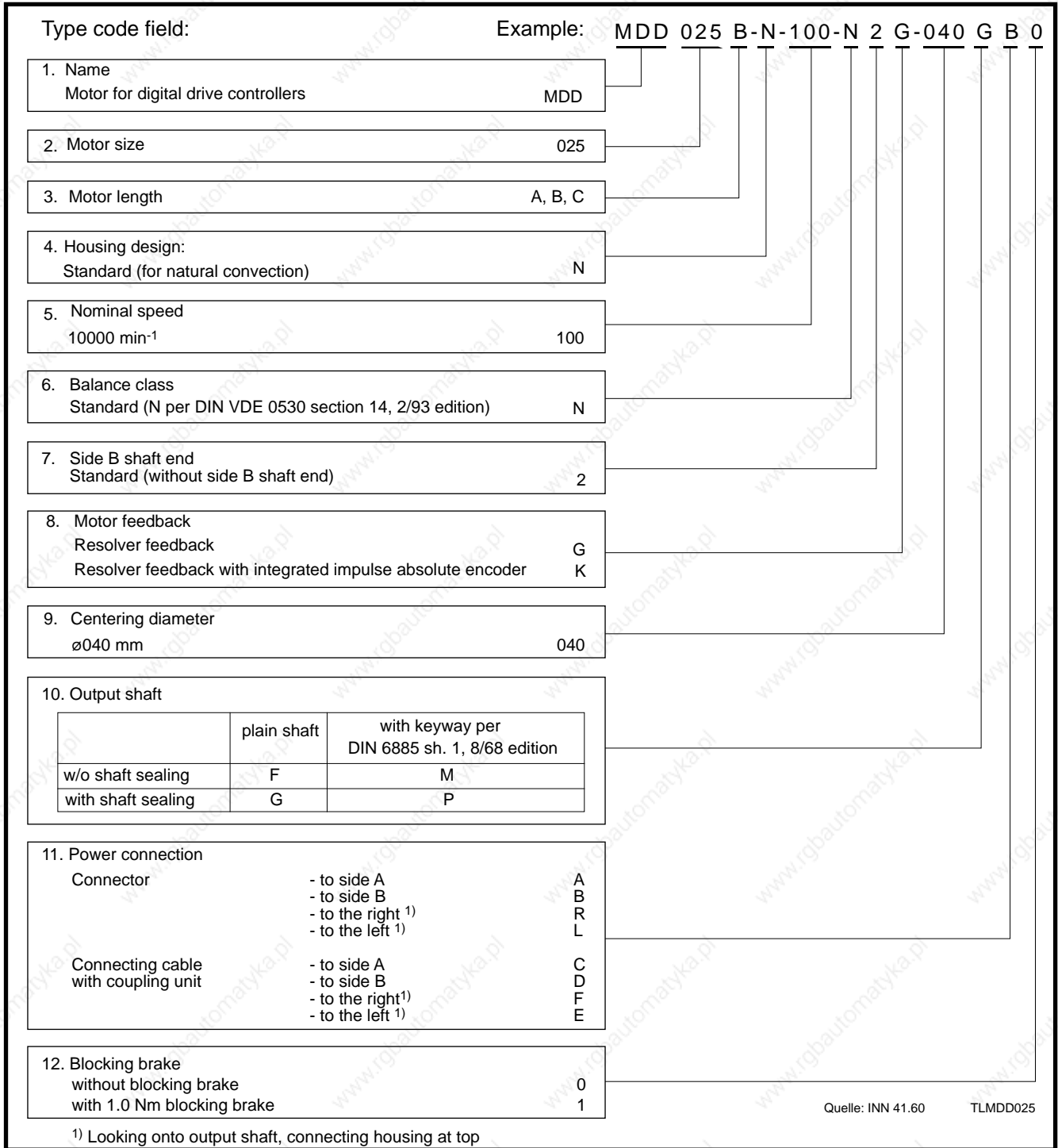

Fig 4.12: Type codes - MDD 025

Empty Page

5. MDD 041

5.1. Technical Data

Designation	Symbol	Unit	Motor type MDD ...		
			041 A-N-100	041 B-N-100	041 C-N-100
Nominal motor speed ¹⁾	n	min ⁻¹	10000	10000	10000
Continuous torque at standstill ²⁾	M_{dN}	Nm	0.64 (0.59) ⁵⁾	1.35 (1.26) ⁵⁾	2.05 (1.93) ⁵⁾
Continuous current at standstill	I_{dN}	A	3.2	7.1	10.3
Theor. maximum torque ³⁾	M_{max}	Nm	3.0	5.85	9.01
Peak current	I_{max}	A	14.4	32.0	46.1
Rotor moment of inertia ⁴⁾	J_M	kgm ²	0.7×10^{-4}	1.3×10^{-4}	1.9×10^{-4}
Torque constant at 20 °C	K_m	Nm/A	0.20	0.19	0.20
Windings resistance at 20 °C	R_A	Ohm	2.4	0.8	0.5
Windings inductance	L_A	mH	7.6	3.6	2.7
Thermal time constant	T_{th}	min	25	25	25
Mass ⁴⁾	m_M	kg	2.8	3.7	4.6

¹⁾ Usable motor speed is determined by the torque requirements of the application. The usable speed n_{max} found in the selection lists of the motor-drive combinations are binding for **standard applications**. The usable speed for other applications can be found using the required torque in the torque-speed characteristics curves.
²⁾ With 60 K overtemperature at the motor housing.
³⁾ Achievable maximum torque is dependent upon the drive used. **Only** those maximum torques M_{max} found in the selection list of the motor-drive combinations are binding.
⁴⁾ without blocking brake
⁵⁾ Parenthetical values apply to motors with blocking brake.

Fig 5.1: Type dependent motor data

Designation	Symbol	Unit	Data
Permissible ambient temperature	T_{um}	°C	0 ... + 45
Permissible storage and transport temperatures	T_L	°C	-20 ... + 80
Maximum installation elevation		m	1000 meters above sea level
Protection category			IP 65 ¹⁾
Insulation classification			F
Housing coat			Black prime coat (RAL 9005)

¹⁾ Does not apply to output shaft: Without shaft sealing protection category is IP 50.
 With shaft sealing protection category is IP 65.

Fig 5.2: General data - MDD 041

Designation	Symbol	Unit	Blocking Brake Data
Principle of action			electrically -actuated release
Holding torque	M_H	Nm	1.2
Nominal voltage	U_N	V	DC 24 ± 10%
Nominal current	I_N	A	0.4
Moment of inertia	J_B	kgm ²	0.08×10^{-4}
Release delay	t_L	ms	30
Clamping delay	t_K	ms	5
Mass	m_B	kg	0.3

Fig 5.3: Technical data - blocking brake

5.2. Torque-Speed Characteristics

The torque-speed characteristics of the MDD 041 line of motors deviate from those depicted in section 2.5.

Figure 5.4 depicts the operating curves of the various motors differentiated in terms of "with or without" blocking brake and "with or without" shaft sealing.

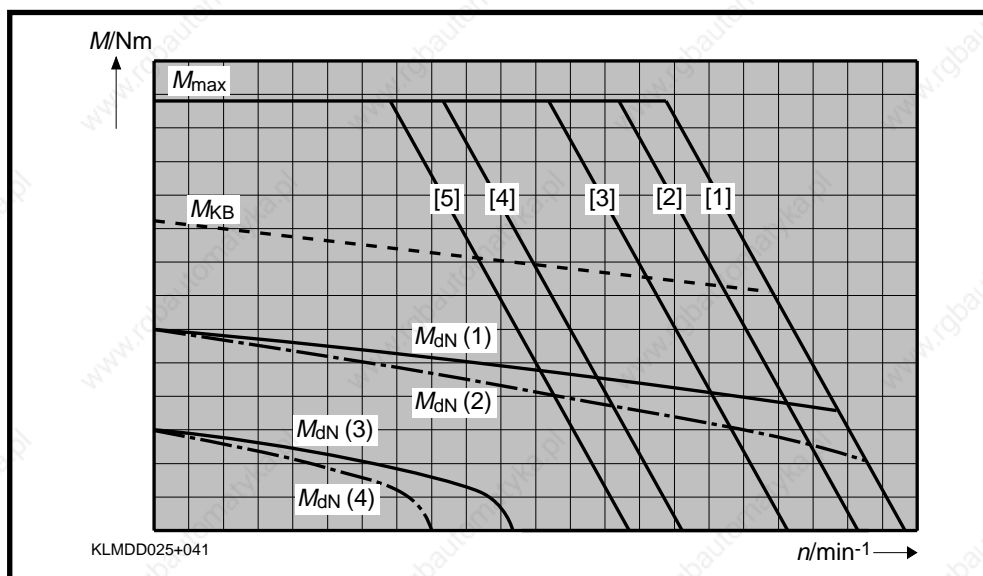

Fig 5.4: Schematic diagram of torque-speed characteristic of an MDD 041

Operating curves Operating curves depict the permissible continuous torque M_{dN} (operating mode S1) and intermittent torque M_{KB} (operating mode S6 as per DIN VDE 0530; status 7/91).

The following allocations apply:

- M_{dN} (1) S1-continuous operating curve of the motor without blocking brake / without shaft sealing
- - - M_{dN} (2) S1-continuous operating curve of the motor without blocking brake / with shaft sealing
- M_{dN} (3) S1-continuous operating curve of the motor with blocking brake / without shaft sealing
- - - M_{dN} (4) S1-continuous operating curve of the motor with blocking brake / with shaft sealing
- - - - - S6-intermittent operating curve at 25 % of ON time of the motor
Maximum duty cycle time equals five minutes.

MDD 041 A at
10000 min⁻¹

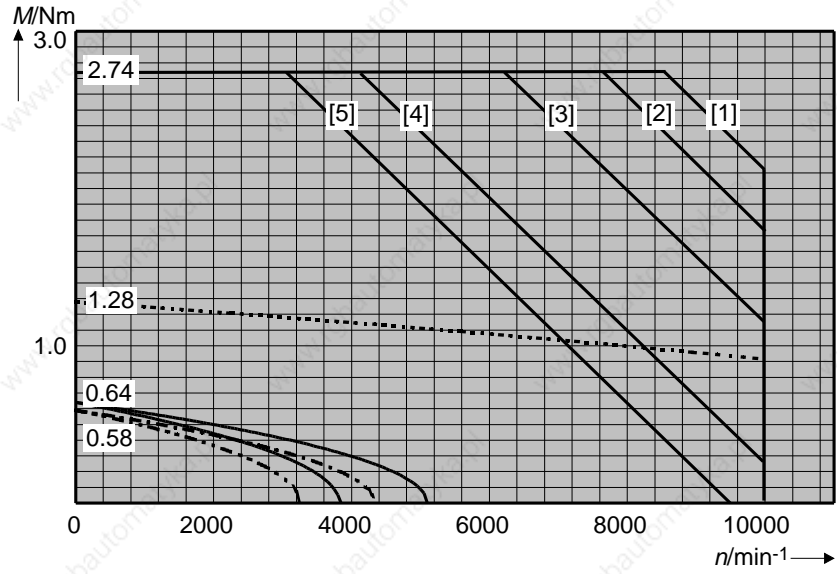

MDD 041 B at
10000 min⁻¹

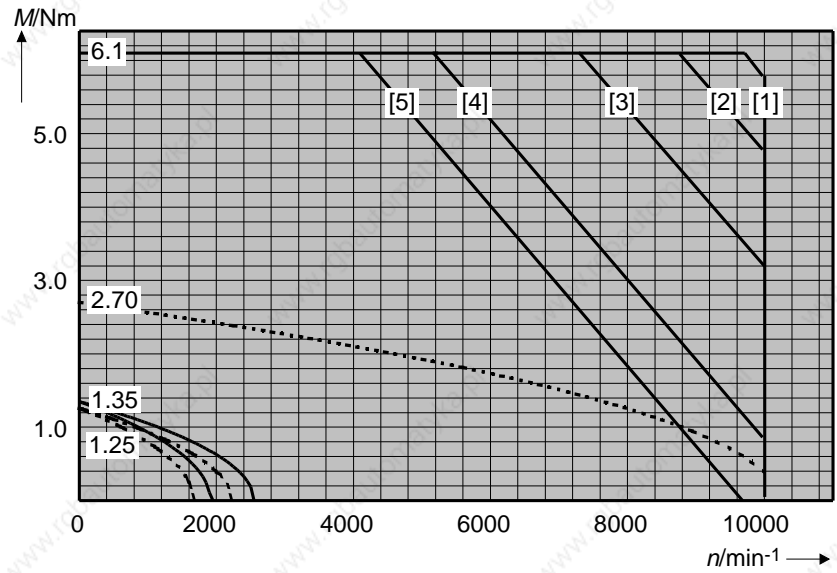

MDD 041 C at
10000 min⁻¹

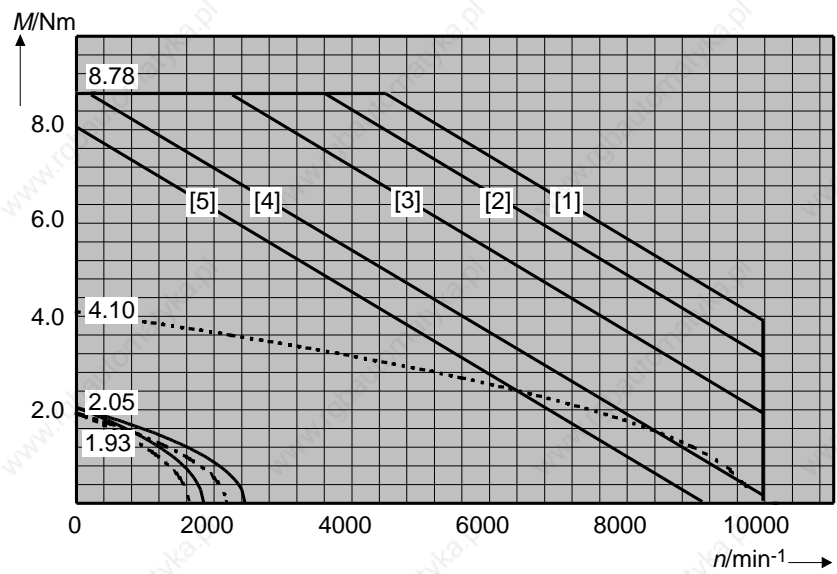

Fig 5.5: Torque-speed characteristics curves - MDD 041

5.3. Shaft Load Capacity

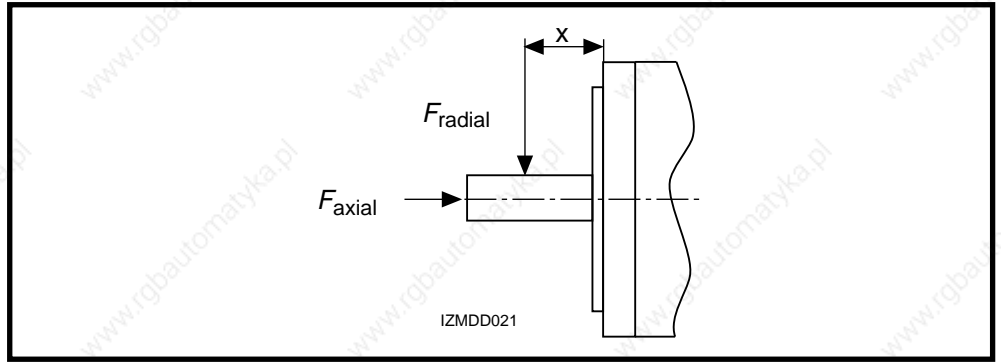

Fig 5.6: Shaft load

Permissible radial force

F_{radial}

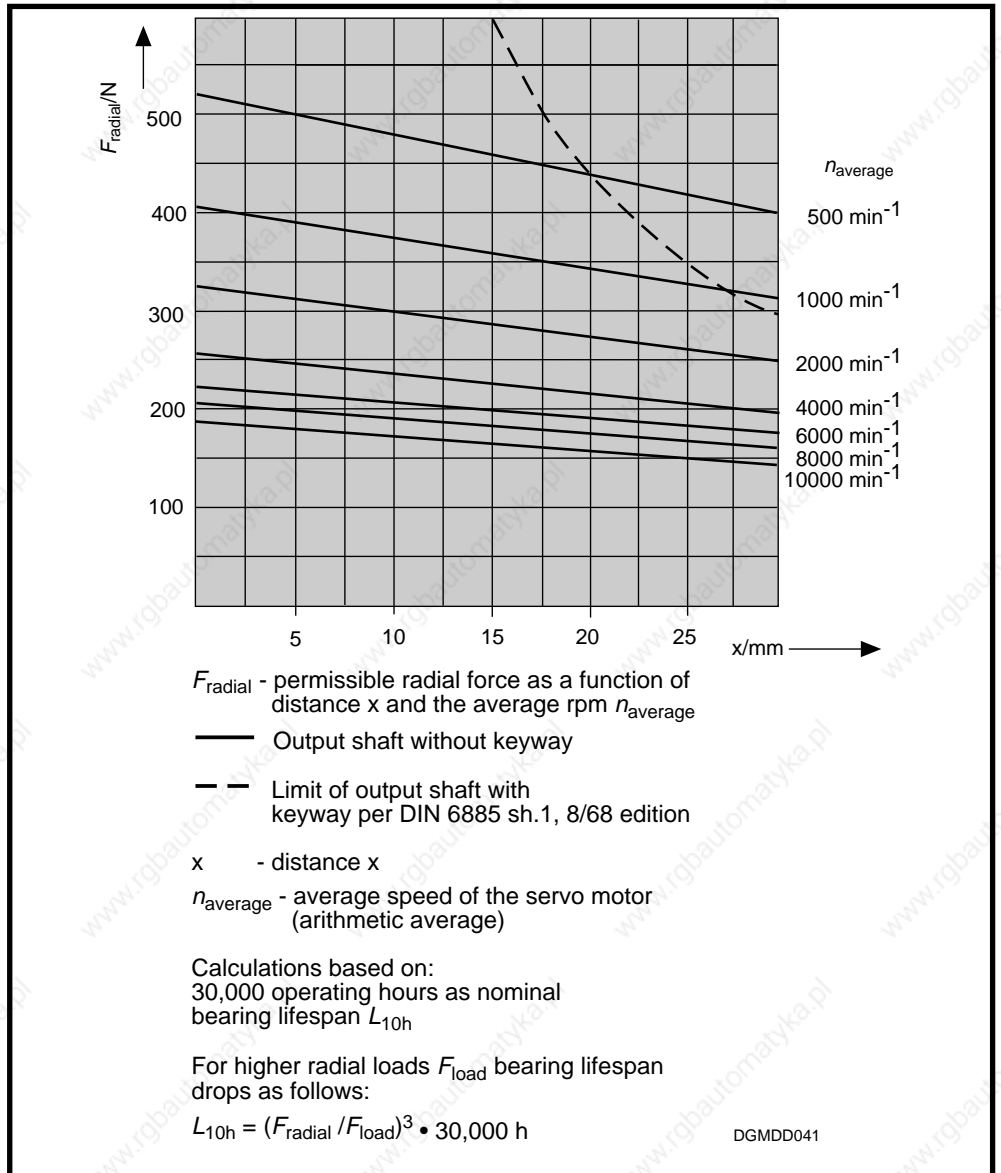

Fig 5.7: Permissible radial force

Permissible axial force

F_{axial}

$$F_{axial} = 0.53 \cdot F_{radial}$$

F_{axial} - permissible axial force

F_{radial} - permissible radial force

5.4. Dimensional Data

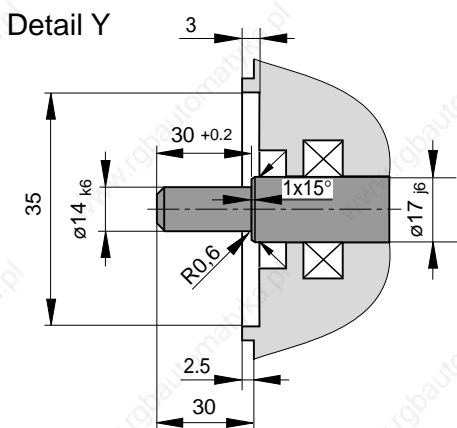
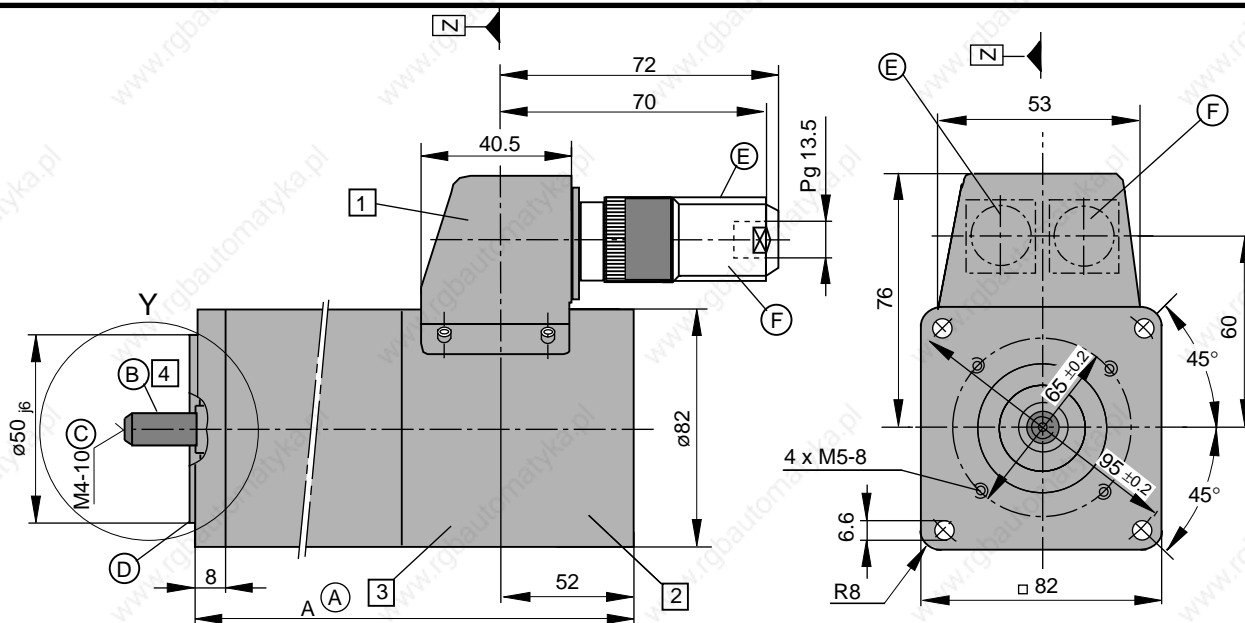

(A) Dimensional table Dim. A

Size	Dim. A 1)
MDD 041 A	178
MDD 041 B	208
MDD 041 C	238

1) Bigger with some options.
The then applicable dimension is indicated with the respective feature.

(B) Concentricity, excentricity and coaxiality to the shaft per DIN 42955, tolerance class R, 12/81 edition.

- (C)** • Shaft end per DIN 748 section 3, 7/75 edition, IEC 72, 1971 edition, cylindrical
- Center hole DS M3-8 per DIN 332 section 2, 5/83 edition
- Max. tightening torque M_A for screws in the threads of the center hole: 0.6 Nm
- Balance class N per DIN VDE 0530 section 14, 2/93 edition

- (D)** Flange type per DIN 42948, 11/65 edition, makes mounting possible
 - as per design B5 (throughholes in flange)
 - as per design B14 (threads in flange)

- (E) Motor power connector**
INS 252 must be ordered separately.

- (F) Feedback connector:**
INS 513 and INS 512 must be ordered separately as possible types.

MBMDD041_1

Fig 5.8: Dimensional data - MDD 041

Available Options

1 Power connection

The output direction of the electrical power connector is selected at the time the order is placed. Possible output direction is either:

- side A or
- side B

The drawing depicts side B as output direction. The dimensions of any other output direction are obtained by virtually turning the connector housing around the Z axis.

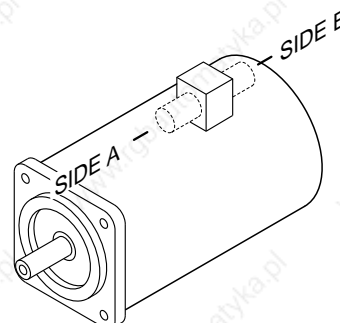

2 Motor feedback

- Resolver feedback
- Resolver feedback with integrated pulse wire absolute encoder

The dimensions are identical.

3 Blocking brake

- without blocking brake
- with blocking brake: 1.0 Nm

Dimensional table for motors with blocking brake

Size	Dim. A
MDD 041 A	203
MDD 041 B	233
MDD 041 C	263

4 Output shaft

- plain shaft (preferred type)
- with keyway per DIN 6885 sheet 1, 8/68 edition
(Note: balanced with entire key!)

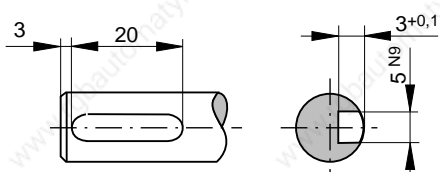

Matching key: DIN 6885-A 5 x 5 x 20

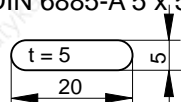

MBMDD041_2

Fig 5.9: Dimensional data - MDD 041 - available options

5.5. Available Versions

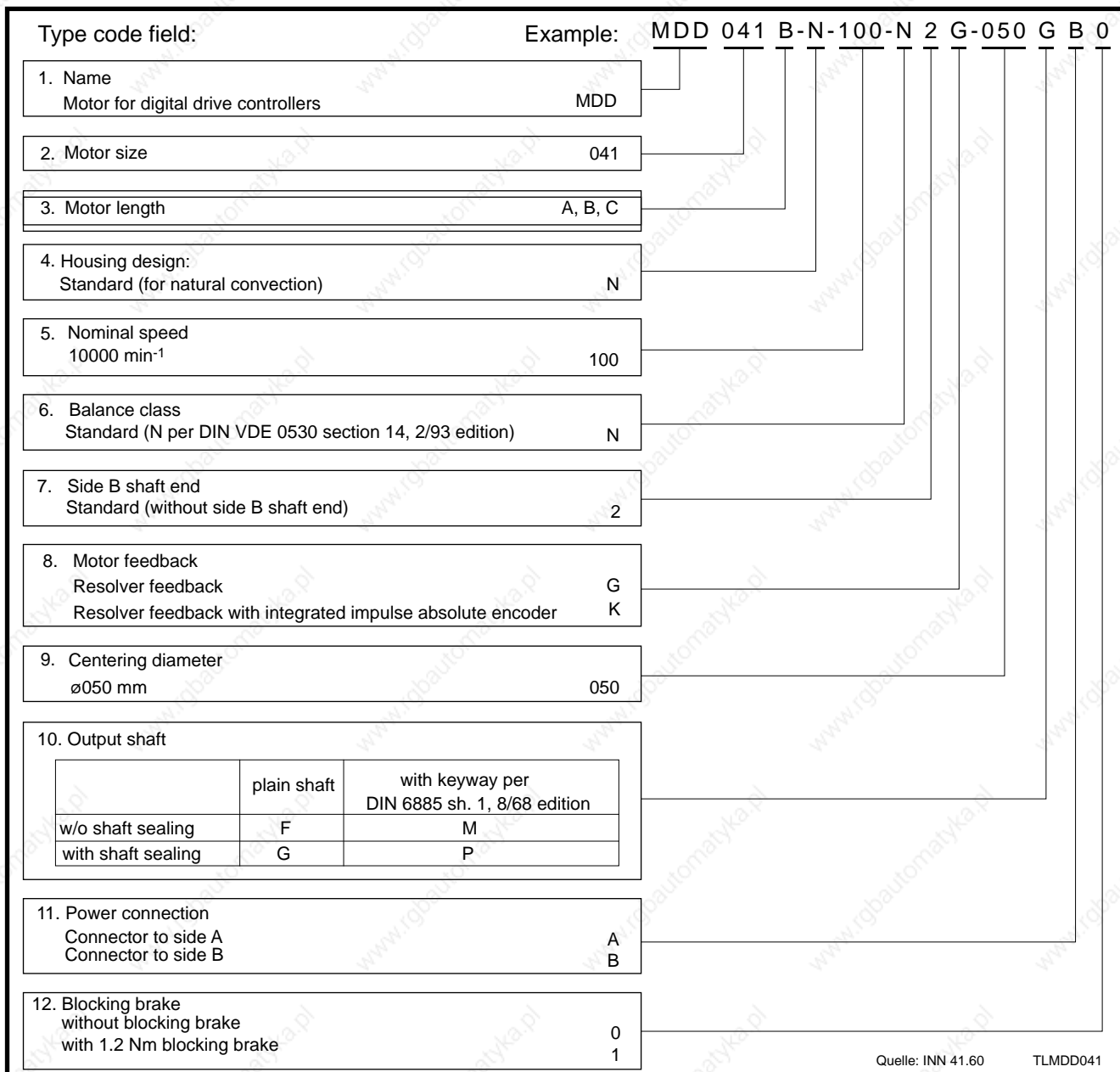

Fig 5.10: Type codes - MDD 041

Empty Page

6. MDD 065

6.1. Technical Data

Designation	Symbol	Unit	Motor type MDD . . .			
			065 A-N-040	065 B-N-040	065 C-N-040	065 D-N-040
Nominal motor speed ¹⁾	n	min ⁻¹	4000	4000	4000	4000
Continuous torque at standstill ²⁾	M_{dN}	Nm	0.8	1.5 (1.7) ⁵⁾	2.1 (2.7) ⁵⁾	2.7 (3.5) ⁵⁾
Continuous current at standstill	I_{dN}	A	1.8	3,5 (4.0) ⁵⁾	5.5 (7.1) ⁵⁾	6.3 (8.1) ⁵⁾
Theor. maximum torque ³⁾	M_{max}	Nm	2.3	4,4	6.1	7.8
Peak current	I_{max}	A	8.1	15.9	24.6	28.5
Rotor moment of inertia ⁴⁾	J_M	kgm ²	1.4×10^{-4}	2.2×10^{-4}	3.0×10^{-4}	3.8×10^{-4}
Torque constant at 20 °C	K_m	Nm/A	0.44	0.43	0.38	0.43
Windings resistance at 20 °C	R_A	Ohm	16	5.22	2.25	2.0
Windings inductance	L_A	mH	20.3	7.4	3.6	2.6
Thermal time constant	T_{th}	min	30	30 (15) ⁵⁾	30 (15) ⁵⁾	30 (15) ⁵⁾
Mass ⁴⁾	m_M	kg	3.2	3.9	4.6	5.3
			065 A-N-060	065 B-N-060	065 C-N-060	065 D-N-060
Nominal motor speed ¹⁾	n	min ⁻¹	6000	6000	6000	6000
Continuous torque at standstill ²⁾	M_{dN}	Nm	0.8	1.5 (1.7) ⁵⁾	2.1 (2.7) ⁵⁾	2.7 (3.5) ⁵⁾
Continuous current at standstill	I_{dN}	A	2.6	5.9 (6.7) ⁵⁾	7.9 (10.2) ⁵⁾	10.3 (13.3) ⁵⁾
Theor. maximum torque ³⁾	M_{max}	Nm	2.3	4.4	6.1	7.8
Peak current	I_{max}	A	11.6	26.3	35.4	46.2
Rotor moment of inertia ⁴⁾	J_M	kgm ²	1.4×10^{-4}	2.2×10^{-4}	3.0×10^{-4}	3.8×10^{-4}
Torque constant at 20 °C	K_m	Nm/A	0.31	0.26	0.27	0.26
Windings resistance at 20 °C	R_A	Ohm	7.75	2.0	1.16	0.74
Windings inductance	L_A	mH	6.4	2.2	1.3	0.9
Thermal time constant	T_{th}	min	30	30 (15) ⁵⁾	30 (15) ⁵⁾	30 (15) ⁵⁾
Mass ⁴⁾	m_M	kg	3.2	3.9	4.6	5.3

1) Usable motor speed is determined by the torque requirements of the application. The usable speed n_{max} found in the selection lists of the motor-drive combinations are binding for **standard applications**. The usable speed for other applications can be found using the required torque in the torque-speed characteristics curves.

2) With 60 K overtemperature at the motor housing.

3) Achievable maximum torque is dependent upon the drive used. **Only** those maximum torques M_{max} found in the selection list of the motor-drive combinations are binding.

4) without blocking brake

5) Parenthetical values apply to motors with surface cooling

Fig 6.1: Type dependent motor data

Designation	Symbol	Unit	Data
Permissible ambient temperature	T_{um}	°C	0 ... + 45
Permissible storage and transport temperatures	T_L	°C	-20 ... + 80
Maximum installation elevation		m	1000 meters above sea level
Protection category			IP 65
Insulation classification			F
Housing coat			Black prime coat (RAL 9005)

Fig 6.2: General data - MDD 065

Designation	Symbol	Unit	Blocking Brake Data
Principle of action			electrically actuated release
Holding torque	M_H	Nm	3.0
Nominal voltage	U_N	V	DC 24 ± 10%
Nominal current	I_N	A	0.6
Moment of inertia	J_B	kgm ²	0.38 × 10 ⁻⁴
Release delay	t_L	ms	30
Clamping delay	t_K	ms	15
Mass	m_B	kg	0.55

Fig 6.3: Technical data - blocking brake

6.2. Torque-Speed Characteristics

MDD 065 A at
4000 min⁻¹

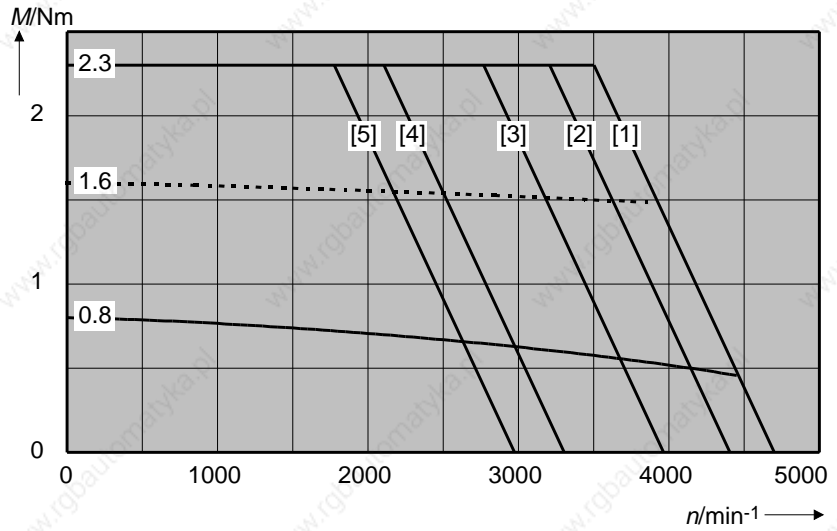

MDD 065 A at
6000 min⁻¹

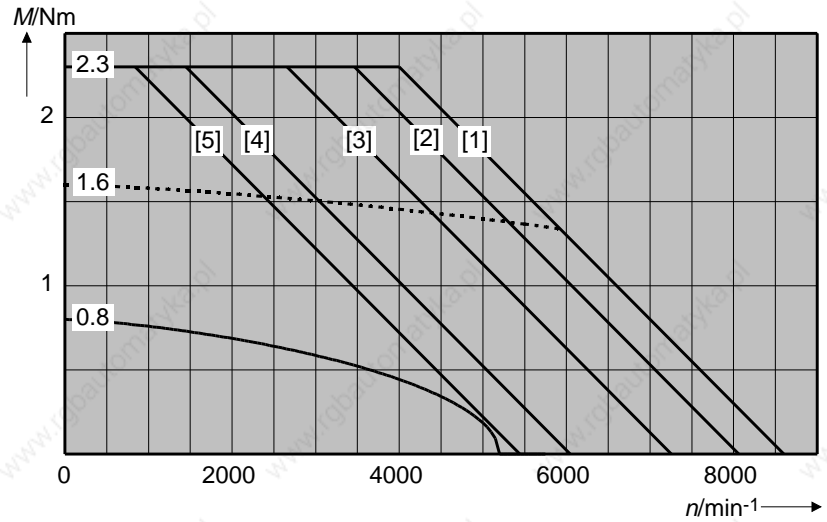

MDD 065 B at
4000 min⁻¹

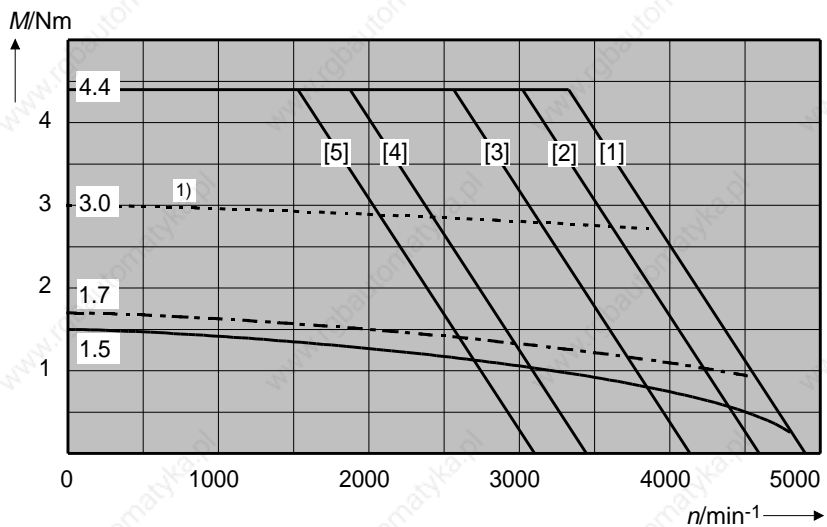

¹⁾ Shown: ON time of surface-cooled motor equals 40%.

Fig 6.4: Torque-speed characteristics curves - MDD 065

MDD 065 B at 6000 min⁻¹

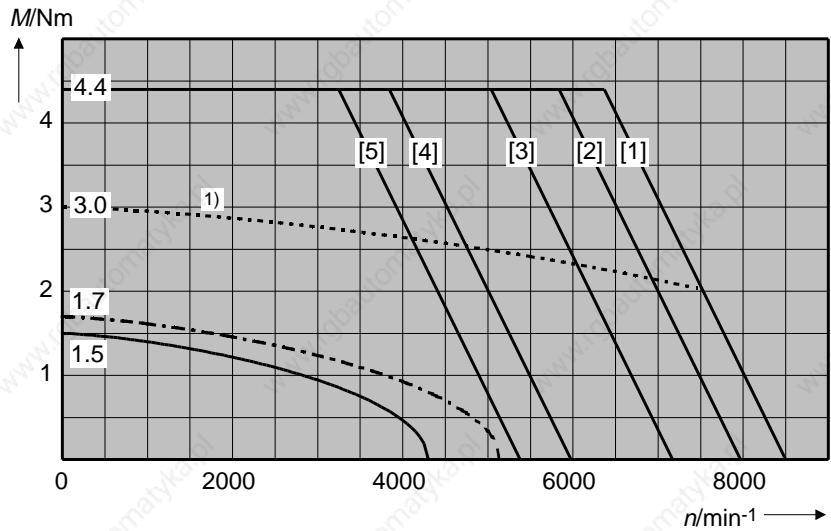

MDD 065 C at 4000 min⁻¹

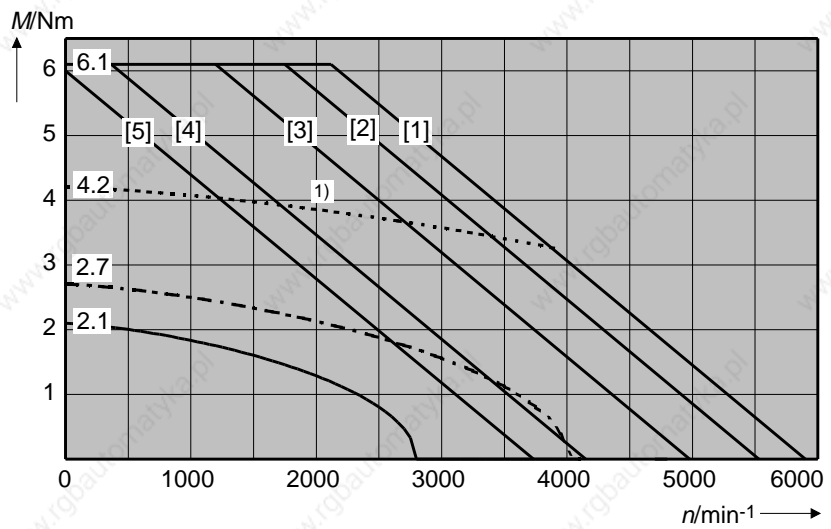

MDD 065 C at 6000 min⁻¹

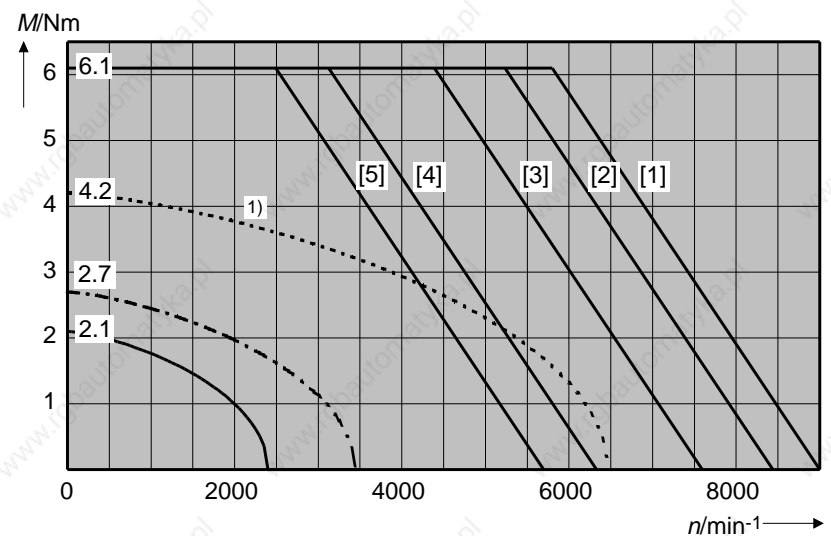

1) Shown: ON time of surface-cooled motor equals 40%.

Fig 6.5: Torque-speed characteristics curves - MDD 065

MDD 065 D at
4000 min⁻¹

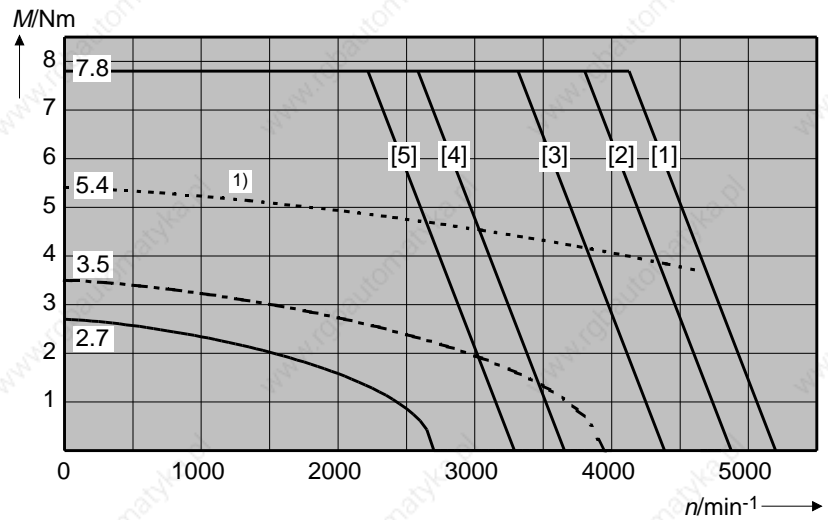

MDD 065 D at
6000 min⁻¹

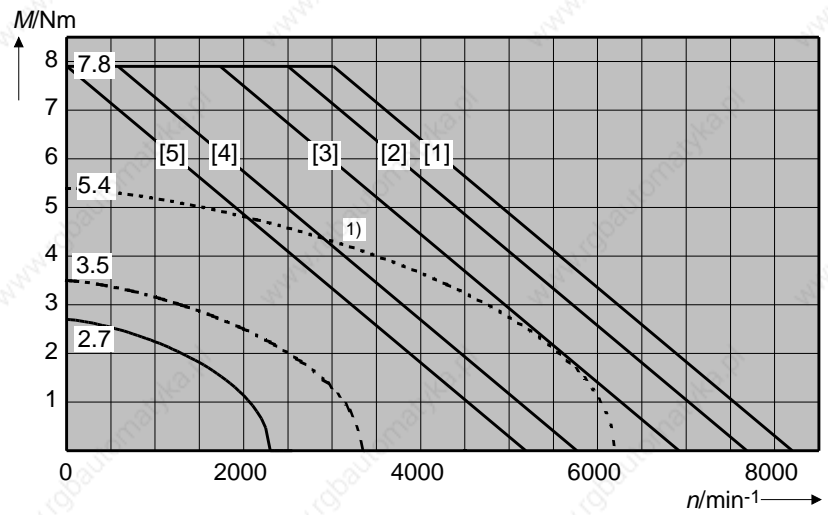

1) Shown: ON time of surface-cooled motor equals 40%.

Fig 6.6: Torque-speed characteristics curves - MDD 065

6.3. Shaft Load Capacity

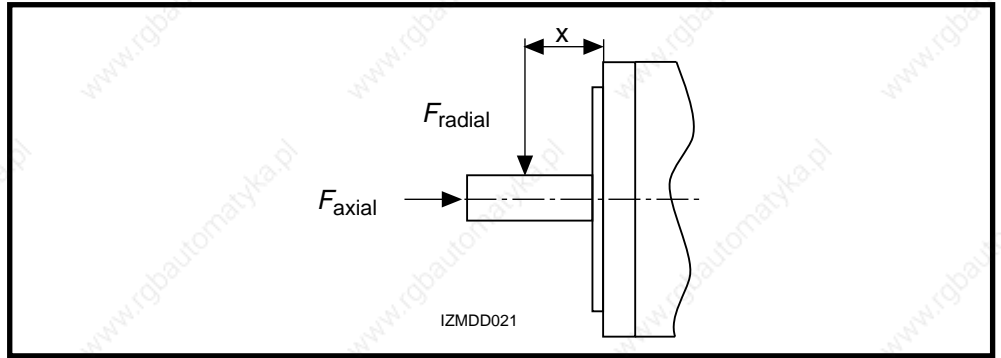

Fig 6.7: Shaft load

Permissible radial force

F_{radial}

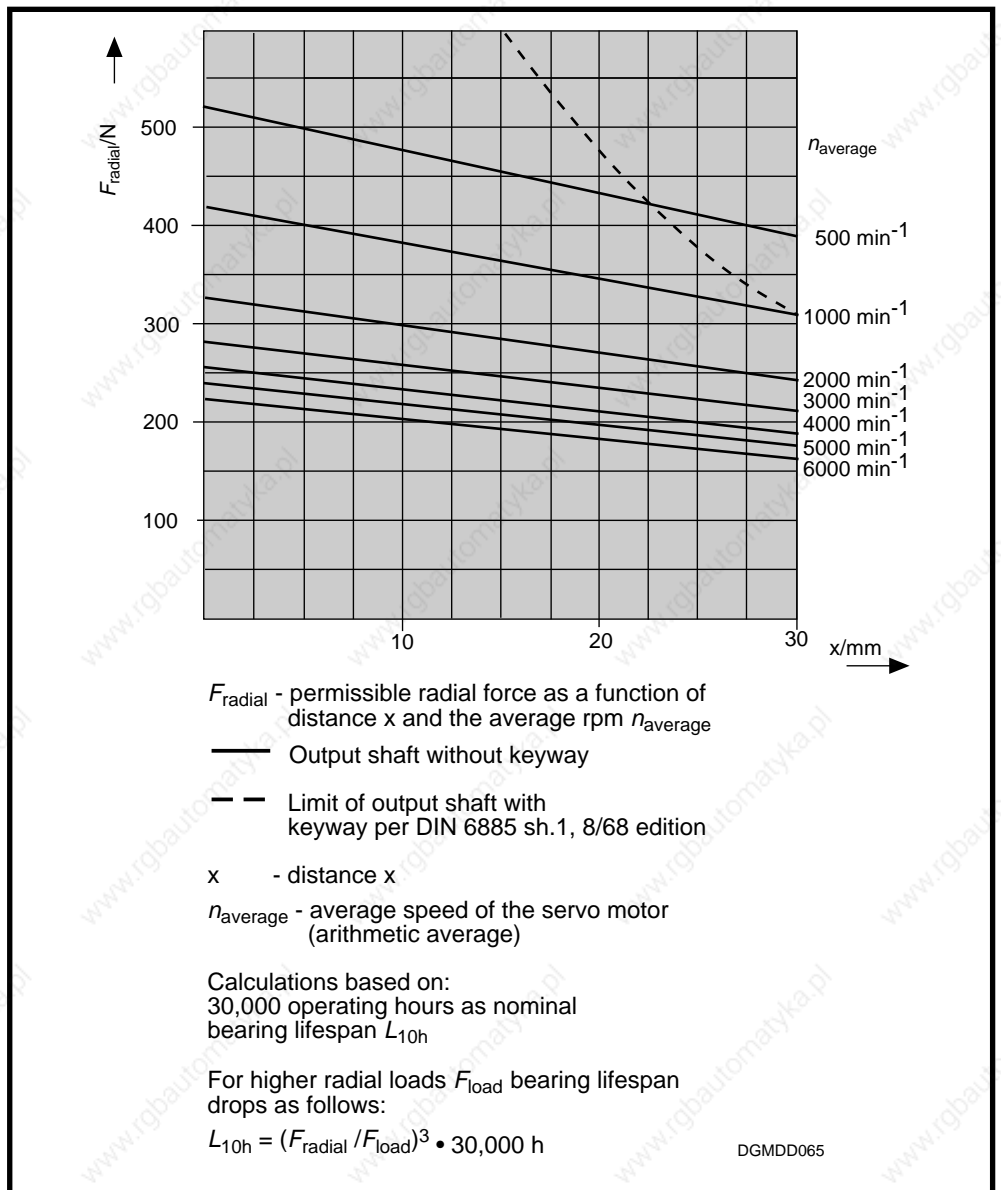

Fig 6.8: Permissible radial force

Permissible axial force

F_{axial}

$$F_{axial} = 0.57 \cdot F_{radial}$$

F_{axial} - permissible axial force

F_{radial} - permissible radial force

6.4. Dimensional Data

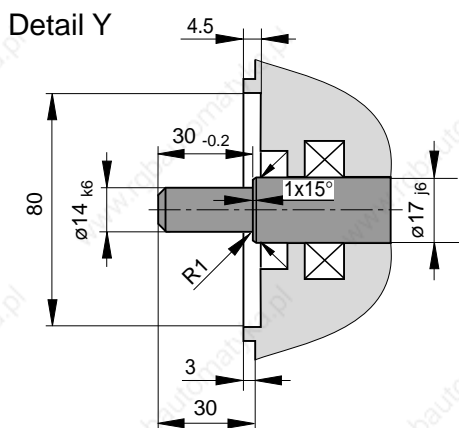
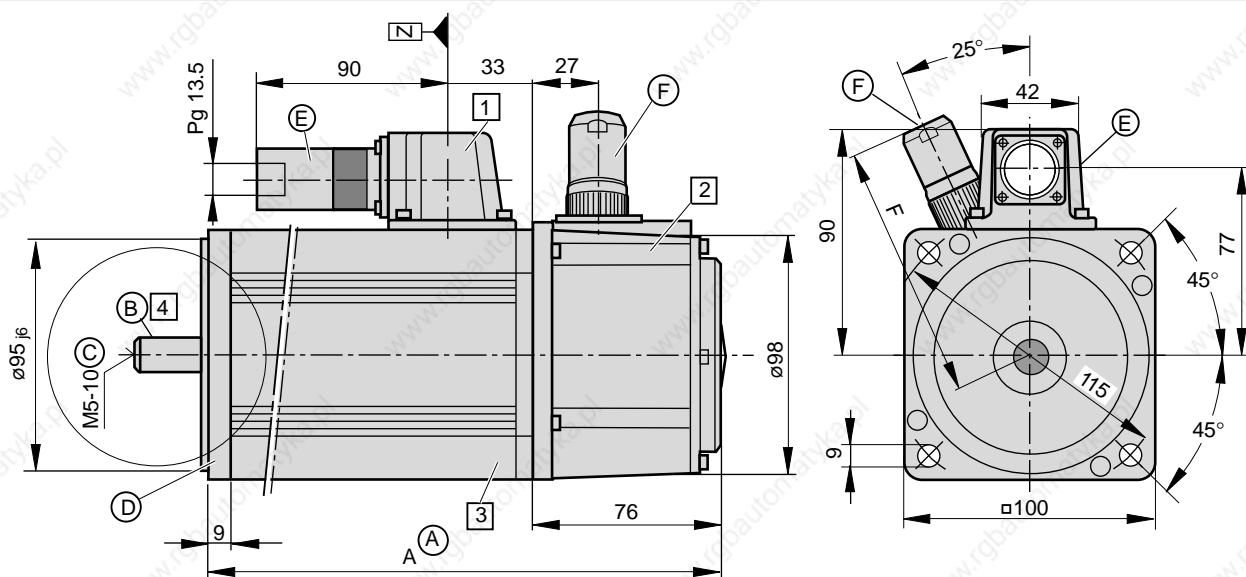

(A) Dimensional table Dim. A

Size	Dim. A ¹⁾
MDD 065 A	163
MDD 065 B	178
MDD 065 C	193
MDD 065 D	208

1) Bigger with some options.
The then applicable dimension is indicated with the respective feature.

(B) Concentricity, excentricity and coaxiality to the shaft per DIN 42955, tolerance class R, 12/81 edition.

- (C)**
 - Shaft end per DIN 748 section 3, 7/75 edition, IEC 72, 1971 edition, cylindrical
 - Center hole DS M3-8 per DIN 332 section 2, 5/83 edition
 - Max. tightening torque M_A for screws in the threads of the center hole: 1 Nm
 - Balance class N per DIN VDE 0530 section 14, 2/93 edition

- (D)** Flange type per DIN 42948, 11/65 edition, makes mounting possible
 - as per design B5 (throughholes in flange)
 - as per design B14 (threads in flange)

- (E) Motor power connector**
INS 252 must be ordered separately.

- (F) Feedback connector:**
INS 513 and INS 512 must be ordered separately as possible types.

Table of dimensions:

Name	Connector type	Dim. F
straight conn.	INS 513	110
	INS 512	112
angle conn.	INS 511	108
	INS 510	

MBMDD065_1

Fig 6.9: Dimensional data - MDD 065

Available Options

1 Power connection

The output direction of the electrical power connector is selected at the time the order is placed. Possible output direction is either:

- side A or
- side B
- to the right
- to the left

The drawing depicts side A as output direction. The dimensions of any other output direction are obtained by virtually turning the connector housing around the Z axis.

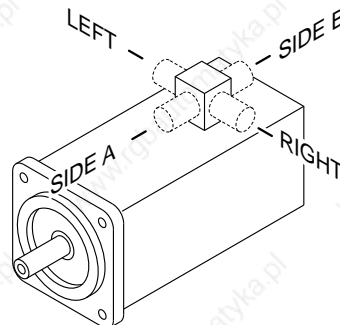

2 Motor feedback

- Digital servo feedback (DSF)
 - Digital servo feedback (DSF) with integrated multturn absolute encoder
- The dimensions are identical.

3 Blocking brake

- without blocking brake
- with blocking brake: 3.0 Nm

Dimensional table for motors with blocking brake

Size	Dim. A
MDD 065 A	187
MDD 065 B	202
MDD 065 C	217
MDD 065 D	232

4 Output shaft

- plain shaft (preferred type)
- with keyway per DIN 6885 sheet 1, 8/68 edition
(Note: balanced with entire key!)

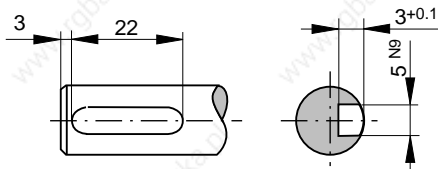

Matching key: DIN 6885-A 5 x 5 x 22

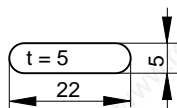

MBMDD065_2

Fig 6.10: Dimensional data - MDD 065 - available options

6.5. Available Versions

Type code field:	Example:	MDD	065	B-N	040	N	2	L	095	G	B	0
1. Name Motor for digital drive controllers	MDD											
2. Motor size	065											
3. Motor length	A, B, C, D											
4. Housing design: Standard (suited for natural convection and surface-cooling)	N											
5. Nominal speed 4000 min ⁻¹ 6000 min ⁻¹	040 060											
6. Balance class Standard (R per DIN VDE 0530 section 14, 2/93 edition)	N											
7. Side B shaft end Standard (without side B shaft end)	2											
8. Motor feedback digital servo feedback digital servo feedback with integrated multiturn absolute encoder	L M											
9. Centering diameter ø095 mm	095											
10. Output shaft plain shaft shaft with keyway per DIN 6885 sh. 1, 8/68 edition	G P											
11. Power connection connector to side A connector to side B connector to the right (looking onto motor shaft, connecting housing at top) connector to the left (looking onto motor shaft, connecting housing at top)	A B R L											
12. Blocking brake without blocking brake with 3.0 Nm blocking brake	0 1											

Quelle: INN 41.60 TLMD065

Fig 6.11: Type codes - MDD 065

Empty page

7. MDD 071

7.1. Technical Data

Designation	Symbol	Unit	Motor type MDD ...		
			071 A-N-030	071 B-N-030	071 C-N-030
Nominal motor speed ¹⁾	n	min ⁻¹	3000	3000	3000
Continuous torque at standstill ²⁾	M_{dN}	Nm	2.2	4.4 (6.6) ⁵⁾	6.6 (9.9) ⁵⁾
Continuous current at standstill	I_{dN}	A	3.7	7.3	10.8 (16.2) ⁵⁾
Theoretic maximum torque ³⁾	M_{max}	Nm	6.9	13.6	20.5
Maximum current	I_{max}	A	16.5	32.8	48.6
Moment of inertia of rotor ⁴⁾	J_M	kgm ²	4.4×10^{-4}	8.9×10^{-4}	11.9×10^{-4}
Torque constant at 20 °C	K_m	Nm/A	0.60	0.60	0.61
Windings resistance at 20 °C	R_A	Ohm	4.54	1.60	0.85
Windings inductance	L_A	mH	19.4	9.4	5.9
Thermal time constant	T_{th}	min	45 (20) ⁵⁾	45 (20) ⁵⁾	45 (20) ⁵⁾
Mass ⁴⁾	m_M	kg	6.5	8.8	11
			071 A-N-040	071 B-N-040	071 C-N-040
Nominal motor speed ¹⁾	n	min ⁻¹	4000	4000	4000
Continuous torque at standstill ²⁾	M_{dN}	Nm	2.2	4.4 (6.6) ⁵⁾	6.6 (9.9) ⁵⁾
Continuous current at standstill	I_{dN}	A	5.0	11.0 (16.6) ⁵⁾	14.6 (22.0) ⁵⁾
Theoretic maximum torque ³⁾	M_{max}	Nm	6.9	13.6	20.5
Maximum current	I_{max}	A	22.6	49.3	65.9
Moment of inertia of rotor ⁴⁾	J_M	kgm ²	4.4×10^{-4}	8.9×10^{-4}	11.9×10^{-4}
Torque constant at 20 °C	K_m	Nm/A	0.44	0.40	0.45
Windings resistance at 20 °C	R_A	Ohm	2.61	0.67	0.50
Windings inductance	L_A	mH	11.5	4.1	3.4
Thermal time constant	T_{th}	min	45 (20) ⁵⁾	45 (20) ⁵⁾	45 (20) ⁵⁾
Mass ⁴⁾	m_M	kg	6.5	8.8	11
			071 A-N-060	071 B-N-060	071 C-N-060
Nominal motor speed ¹⁾	n	min ⁻¹	6000	6000	6000
Continuous torque at standstill ²⁾	M_{dN}	Nm	2.2	4.4 (6.6) ⁵⁾	6.6 (9.9) ⁵⁾
Continuous current at standstill	I_{dN}	A	7.5	15.0 (22.6) ⁵⁾	22.1 (33.2) ⁵⁾
Theor. maximum torque ³⁾	M_{max}	Nm	6.8	13.6	20.6
Maximum current	I_{max}	A	33.6	67.7	99.3
Moment of inertia of rotor ⁴⁾	J_M	kgm ²	4.4×10^{-4}	8.9×10^{-4}	11.9×10^{-4}
Torque constant at 20 °C	K_m	Nm/A	0.29	0.29	0.30
Windings resistance at 20 °C	R_A	Ohm	1.18	0.37	0.22
Windings inductance	L_A	mH	5.2	2.2	1.4
Thermal time constant	T_{th}	min	45 (20) ⁵⁾	45 (20) ⁵⁾	45 (20) ⁵⁾
Mass ⁴⁾	m_M	kg	6.5	8.8	11

¹⁾ Usable motor speed is determined by the torque requirements of the application. The usable speed n_{max} found in the selection lists of the motor-drive combinations are binding for **standard applications**. The usable speed for other applications can be found using the required torque in the torque-speed characteristics curves

²⁾ With 60 K overtemperature at the motor housing.

³⁾ Achievable maximum torque is dependent upon the drive used. **Only** those maximum torques M_{max} found in the selection list of the motor-drive combinations are binding.

⁴⁾ Without blocking brake, without blower

⁵⁾ Parenthetical values apply to motors with surface cooling.

Fig 7.1: Type dependent motor data

Designation	Symbol	Unit	Data
Permissible ambient temperature	T_{um}	°C	0 ... + 45
Permissible storage and transport temperature	T_L	°C	-20 ... + 80
Maximum installation elevation		m	1000 meters above sea level
Protection category			IP 65
Insulation classification			F
Housing coat			Black prime coat (RAL 9005)

Fig 7.2: General data - MDD 071

Designation	Symbol	Unit	Data Blocking Brake	
Principle of action			electrically- actuated release	
Holding torque	M_H	Nm	3.0	6.5
Nominal voltage	U_N	V	DC 24 ± 10%	DC 24 ± 10%
Nominal current	I_N	A	0.6	0.7
Moment of inertia	J_B	kgm ²	0.38 x 10 ⁻⁴	1.06 x 10 ⁻⁴
Release delay	t_L	ms	30	60
Clamping delay	t_K	ms	15	20
Mass	m_B	kg	0.3	0.5

Fig 7.3: Technical data - blocking brake

7.2. Torque-Speed Characteristics

MDD 071 A at
3000 min⁻¹

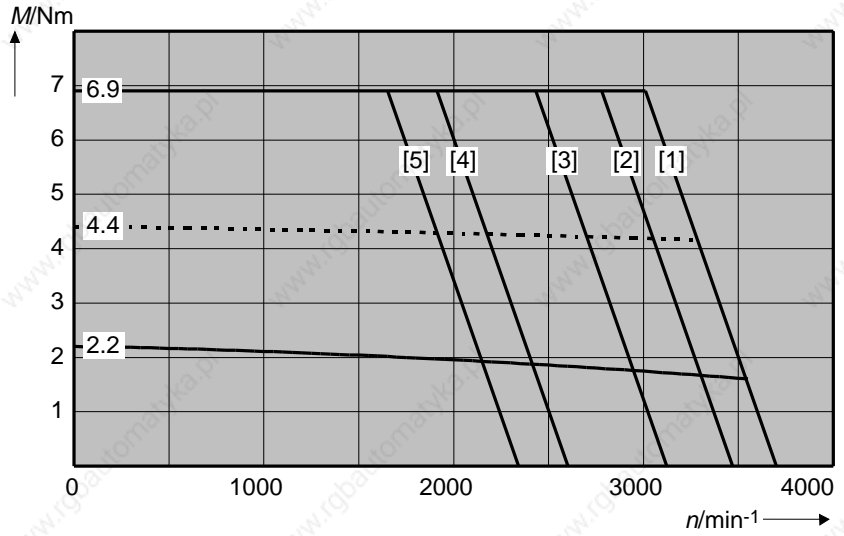

MDD 071 A at
4000 min⁻¹

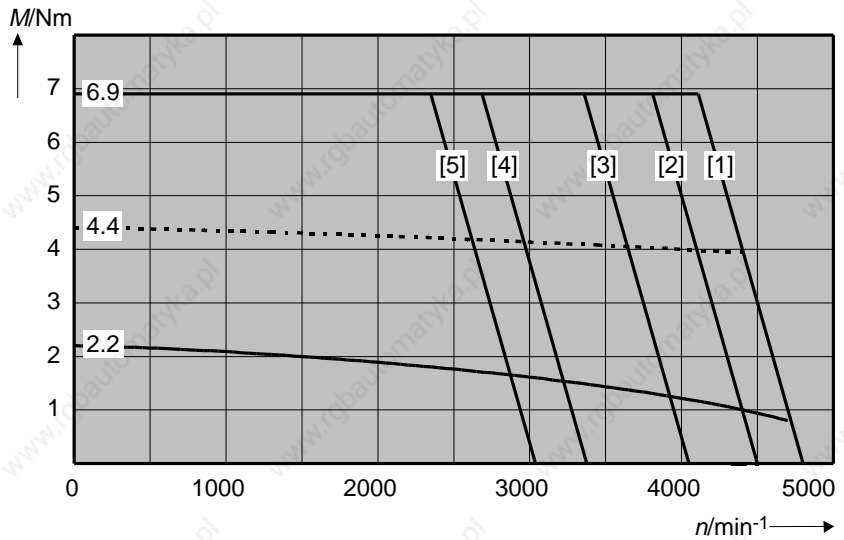

MDD 071 A at
6000 min⁻¹

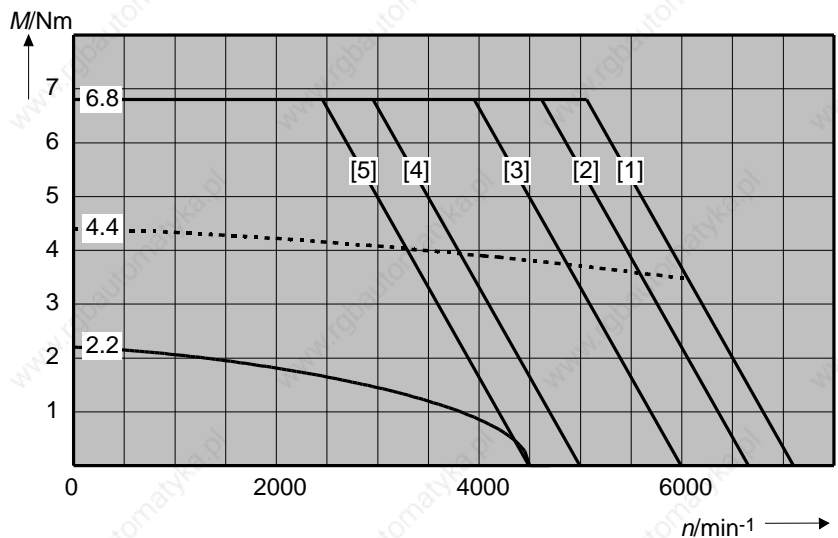
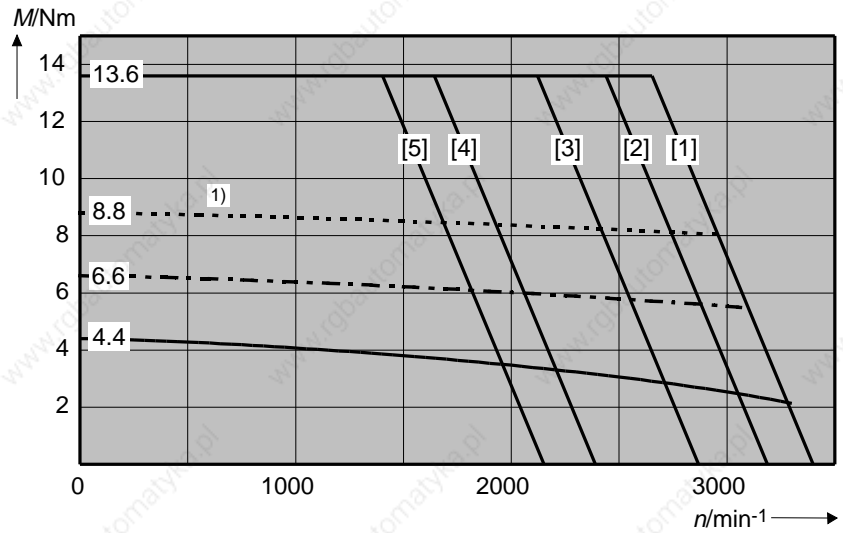
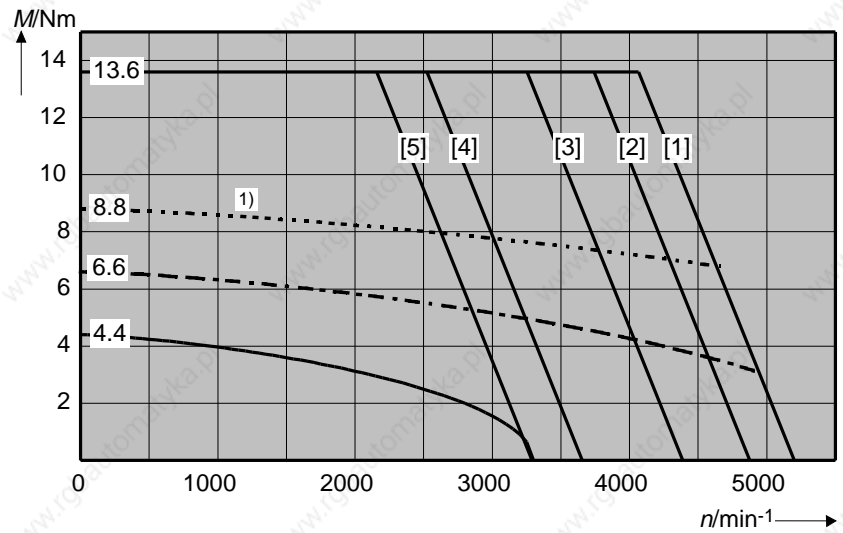

Fig 7.4: Torque-speed characteristics curves - MDD 071

MDD 071 B at
3000 min⁻¹



MDD 071 B at
4000 min⁻¹



MDD 071 B at
6000 min⁻¹

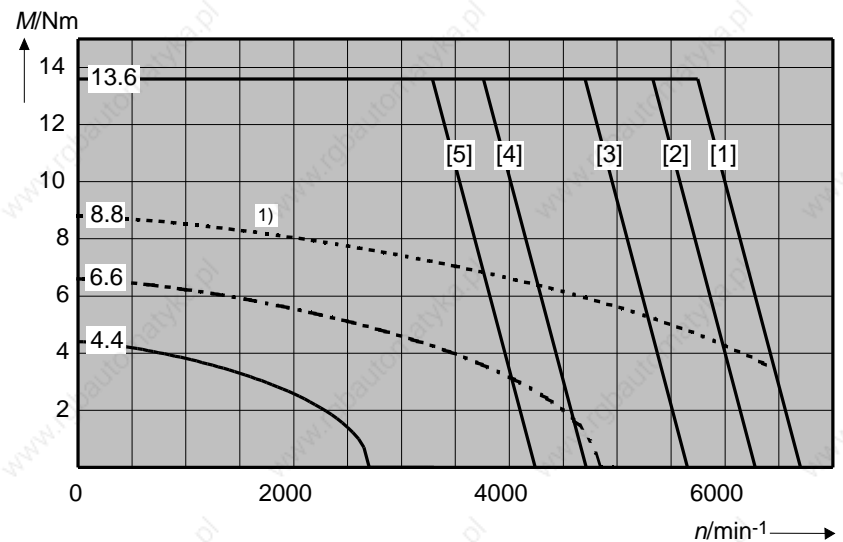

1) Shown: ON time of surface-cooled motor equals 56%.

Fig 7.5: Torque-speed characteristics curves - MDD 071

MDD 071 C at
3000 min⁻¹

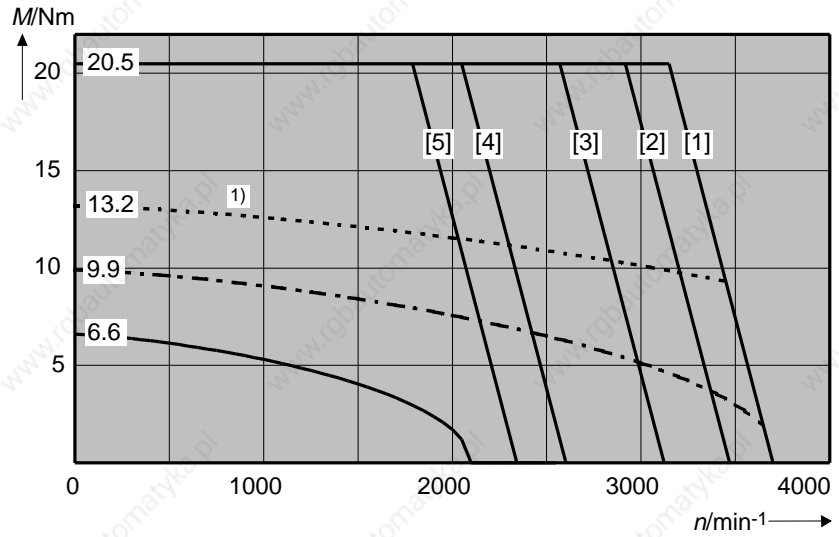

MDD 071 C at
4000 min⁻¹

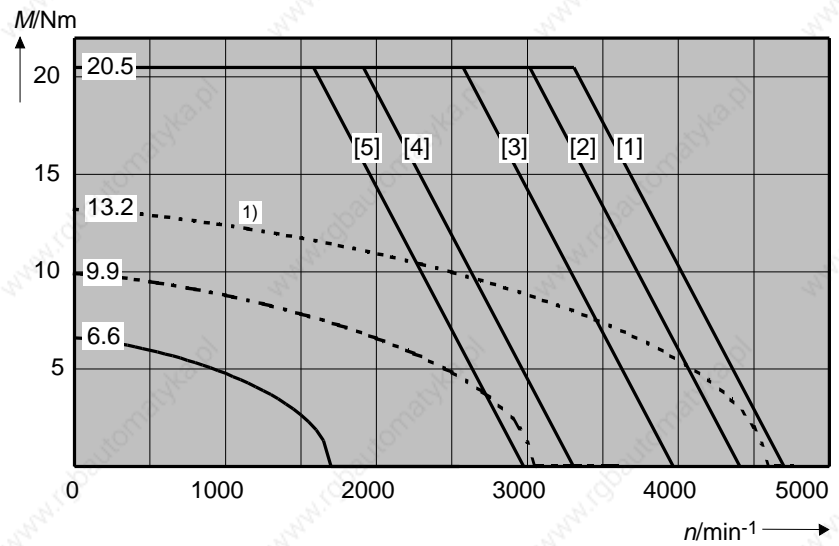

MDD 071 C at
6000 min⁻¹

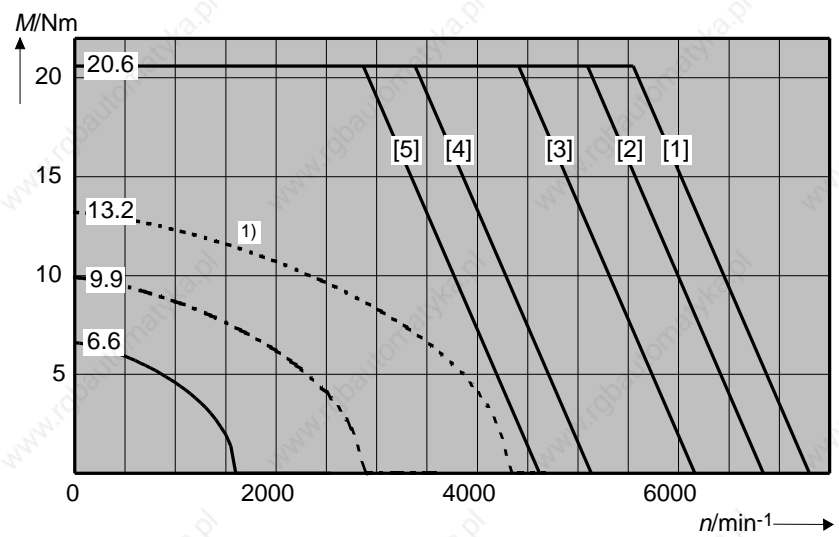

1) Shown: ON time of surface-cooled motor equals 56%.

Fig 7.6: Torque-speed characteristics curves MDD 071

7.3. Shaft Load Capacity

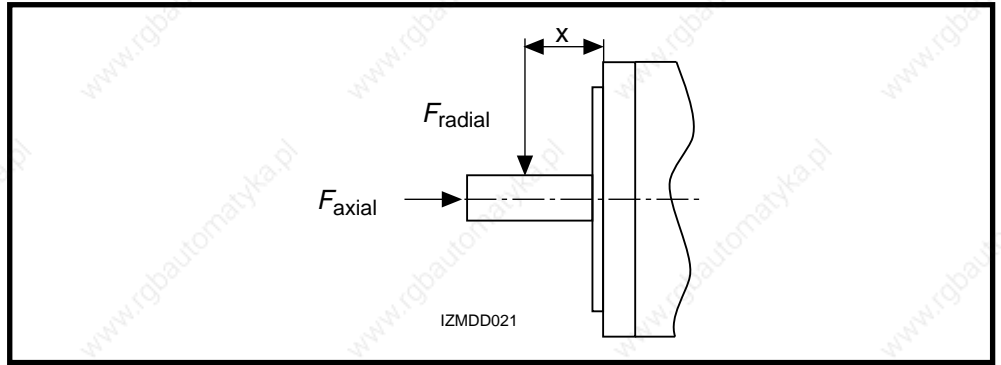

Fig 7.7: Shaft load

Permissible radial force

F_{radial}

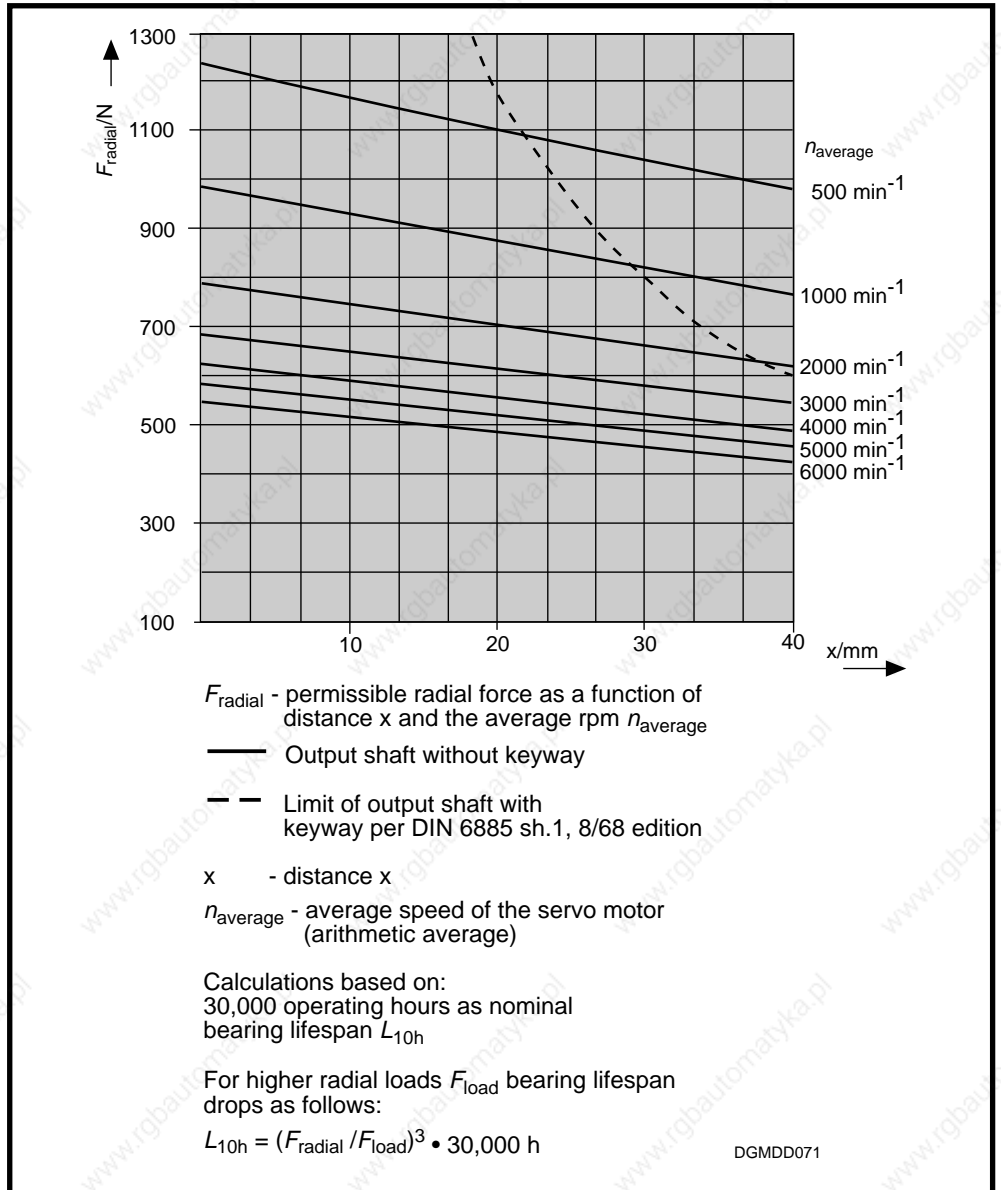

Fig 7.8: Permissible radial force

Permissible axial force

F_{axial}

$$F_{axial} = 0.50 \cdot F_{radial}$$

F_{axial} - permissible axial force

F_{radial} - permissible radial force

7.4. Dimensional Data

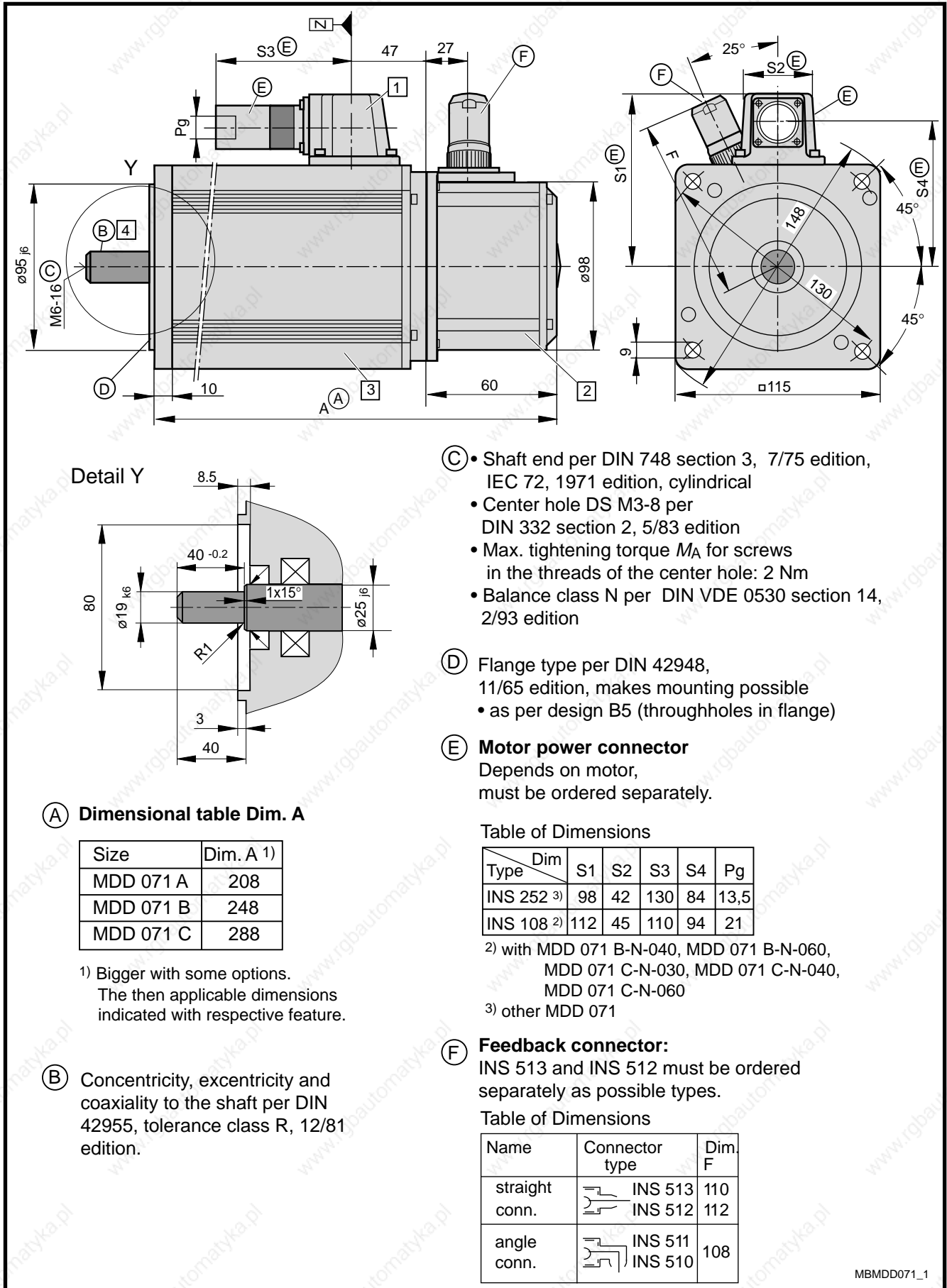

Fig 7.9: Dimensional data - MDD 071

Available Options

1 Power connection

The output direction of the electrical power connector is selected at the time the order is placed. Possible output direction is either:

- side A or
- side B
- to the right
- to the left

The drawing depicts side A as output direction. The dimensions of any other output direction are obtained by virtually turning the connector housing around the Z axis.

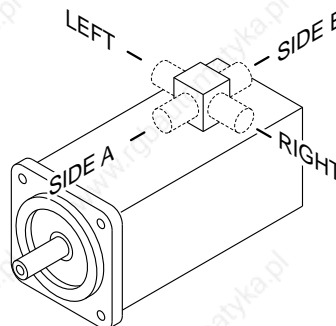

2 Motor feedback

- Digital servo feedback (DSF)
 - Digital servo feedback (DSF) with integrated multiturn absolute encoder
- The dimensions are identical.

3 Blocking brake

- without blocking brake
 - with blocking brake: 3.0 Nm
 - with blocking brake: 6.5 Nm
- The dimensions are identical.

Dimensional table for motor with blocking brake: 6.5 Nm

Size	Dim. A
MDD 071 A	236
MDD 071 B	276
MDD 071 C	316

4 Output shaft

- plain shaft (preferred type)
- with keyway per DIN 6885 sheet 1, 8/68 edition
(Note: balanced with entire key!)

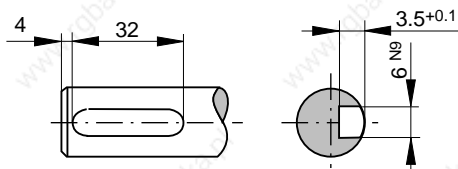

Matching key: DIN 6885-A 6 x 6 x 32

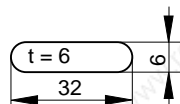

MBMDD071_2

Fig 7.10: Dimensional data MDD 071 -available options

7.5. Available Versions

Type code field:	Example:	MDD	071	B	N	030	N	2	S	095	G	B	0
1. Name Motor for digital drive controllers	MDD												
2. Motor size	071												
3. Motor length	A, B, C												
4. Housing design: Standard (suited for natural convection and surface-cooling)	N												
5. Nominal speed 3000 min ⁻¹ 4000 min ⁻¹ 6000 min ⁻¹	030 040 060												
6. Balance class Standard (R per DIN VDE 0530 section 14, 2/93 edition)	N												
7. Side B shaft end Standard (without side B shaft end)	2												
8. Motor feedback digital servo feedback digital servo feedback with integrated multiturn absolute encoder	S T												
9. Centering diameter ø095 mm	095												
10. Output shaft plain shaft shaft with keyway per DIN 6885 sh. 1, 8/68 edition	G P												
11. Power connection connector to side A connector to side B connector to the right (looking onto motor shaft, connecting housing at top) connector to the left (ooking onto motor shaft, connecting housing at top)	A B R L												
12. Blocking brake without blocking brake with 3.0 Nm blocking brake with 6.5 Nm blocking brake	0 1 2												

Quelle: INN 41.60 TLMD071

Fig 7.11: Type codes - MDD 071

Empty page

8. MDD 090

8.1. Technical Data

Designation	Symbol	Unit	Motor type MDD ...		
			090 A-N-020	090 B-N-020	090 C-N-020
Nominal motor speed ¹⁾	n	min ⁻¹	2000	2000	2000
Continuous torque at standstill ²⁾	M_{dN}	Nm	3.7 (5.0) ⁵⁾	7.2 (10.5) ⁵⁾	10.4 (16.0) ⁵⁾
Continuous current at standstill	I_{dN}	A	4.0 (5.4) ⁵⁾	8.3 (12.2) ⁵⁾	12.1 (18.6) ⁵⁾
Theoretic maximum torque ³⁾	M_{max}	Nm	19.0	39.0	58.6
Maximum current	I_{max}	A	21.9	48.6	72.9
Moment of inertia of rotor ⁴⁾	J_M	kgm ²	20 x 10 ⁻⁴	36 x 10 ⁻⁴	53 x 10 ⁻⁴
Torque constant at 20 °C	K_m	Nm/A	0.93	0.86	0.86
Windings resistance at 20 °C	R_A	Ohm	6.84	1.99	1.20
Windings inductance	L_A	mH	27.7	10.1	6.8
Thermal time constante	T_{th}	min	45 (30) ⁵⁾	60 (45) ⁵⁾	60 (45) ⁵⁾
Mass ⁴⁾	m_M	kg	12.5	18	23
			090 A-N-030	090 B-N-030	090 C-N-030
Nominal motor speed ¹⁾	n	min ⁻¹	3000	3000	3000
Continuous torque at standstill ²⁾	M_{dN}	Nm	3.7 (5.0) ⁵⁾	7.2 (10.5) ⁵⁾	10.4 (16.0) ⁵⁾
Continuous current at standstill	I_{dN}	A	6.3 (8.5) ⁵⁾	12.6 (18.4) ⁵⁾	19.5 (30.0) ⁵⁾
Theoretic maximum torque ³⁾	M_{max}	Nm	17.7	38.9	56.3
Maximum current	I_{max}	A	32.2	72.9	117.8
Moment of inertia of rotor ⁴⁾	J_M	kgm ²	20 x 10 ⁻⁴	36 x 10 ⁻⁴	53 x 10 ⁻⁴
Torque constant at 20 °C	K_m	Nm/A	0.59	0.57	0.53
Windings resistance at 20 °C	R_A	Ohm	3.1	0.91	0.46
Windings inductance	L_A	mH	13.4	4.7	2.6
Thermal time constante	T_{th}	min	45 (30) ⁵⁾	60 (45) ⁵⁾	60 (45) ⁵⁾
Mass ⁴⁾	m_M	kg	12.5	18	23
			090 A-N-040	090 B-N-040	090 C-N-040
Nominal motor speed ¹⁾	n	min ⁻¹	4000	4000	4000
Continuous torque at standstill ²⁾	M_{dN}	Nm	3.7 (5.0) ⁵⁾	7.2 (10.5) ⁵⁾	10.4 (14.6) ⁵⁾
Continuous current at standstill	I_{dN}	A	9.4 (12.7) ⁵⁾	16.7 (24.3) ⁵⁾	24.4 (34.3) ⁵⁾
Theoretic maximum torque ³⁾	M_{max}	Nm	15.0	38.3	58.6
Maximum current	I_{max}	A	41.3	95.3	145.7
Moment of inertia of rotor ⁴⁾	J_M	kgm ²	20 x 10 ⁻⁴	36 x 10 ⁻⁴	53 x 10 ⁻⁴
Torque constant at 20 °C	K_m	Nm/A	0.39	0.43	0.43
Windings resistance at 20 °C	R_A	Ohm	1.30	0.50	0.29
Windings inductance	L_A	mH	14.5	2.6	1.6
Thermal time constante	T_{th}	min	45 (30) ⁵⁾	60 (45) ⁵⁾	60 (45) ⁵⁾
Mass ⁴⁾	m_M	kg	12.5	18	23

¹⁾ Usable motor speed is determined by the torque requirements of the application. The usable speed n_{max} found in the selection lists of the motor-drive combinations are binding for **standard applications**. The usable speed for other applications can be found using the required torque in the torque-speed characteristics curves

²⁾ With 60 K overtemperature at the motor housing.

³⁾ Achievable maximum torque is dependent upon the drive used. **Only** those maximum torques M_{max} found in the selection list of the motor-drive combinations are binding.

⁴⁾ Without blocking brake, without blower

⁵⁾ Parenthetical values apply to motors with surface cooling.

Fig 8.1: Type dependent motor data

Designation	Symbol	Unit	Data
Permissible ambient temperature	T_{um}	°C	0 ... + 45
Permissible storage and transport temperature	T_L	°C	-20 ... + 80
Maximum installation elevation		m	1000 meters above sea level
Protection category			IP 65
Insulation classification			F
Housing coat			Black prime coat (RAL 9005)

Fig 8.2: General data MDD 090

Designation	Symbol	Unit	Data Blocking Brake	
Principle of action			electrically actuated release	
Holding torque	M_H	Nm	6.5	11
Nominal voltage	U_N	V	DC 24 ± 10%	DC 24 ± 10%
Nominal current	I_N	A	0.5	0.5
Moment of inertia	J_B	kgm ²	1.06 x 10 ⁻⁴	1.06 x 10 ⁻⁴
Release delay	t_L	ms	60	60
Clamping delay	t_K	ms	20	20
Mass	m_B	kg	0.5	0.5

Fig 8.3: Technical data - blocking brake

8.2. Torque-Speed Characteristics

MDD 090 A at
2000 min⁻¹

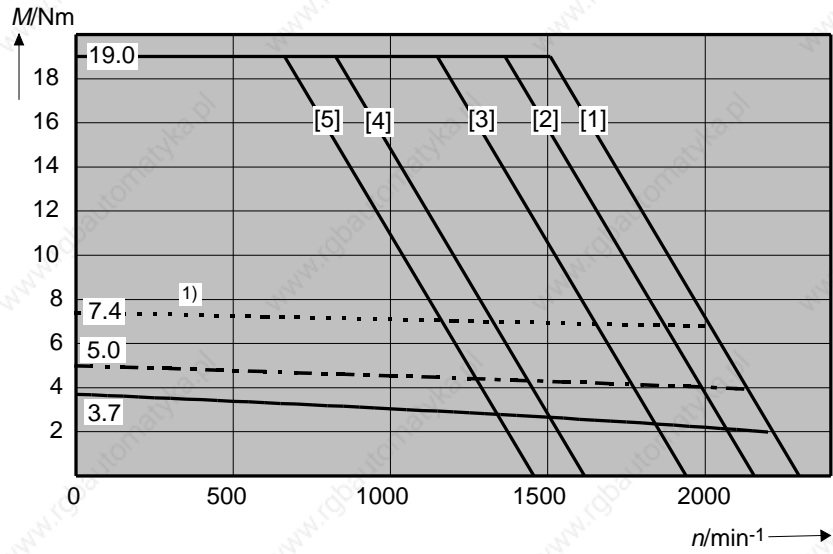

MDD 090 A at
3000 min⁻¹

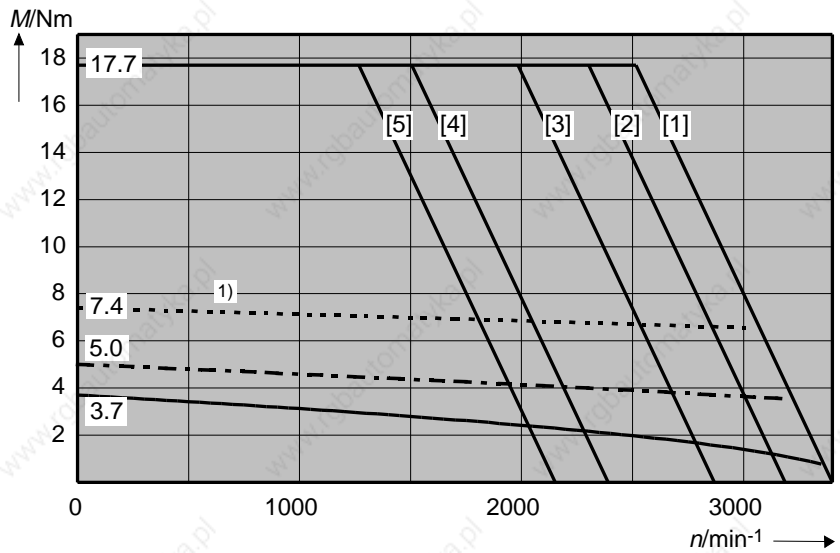

MDD 090 A at
4000 min⁻¹

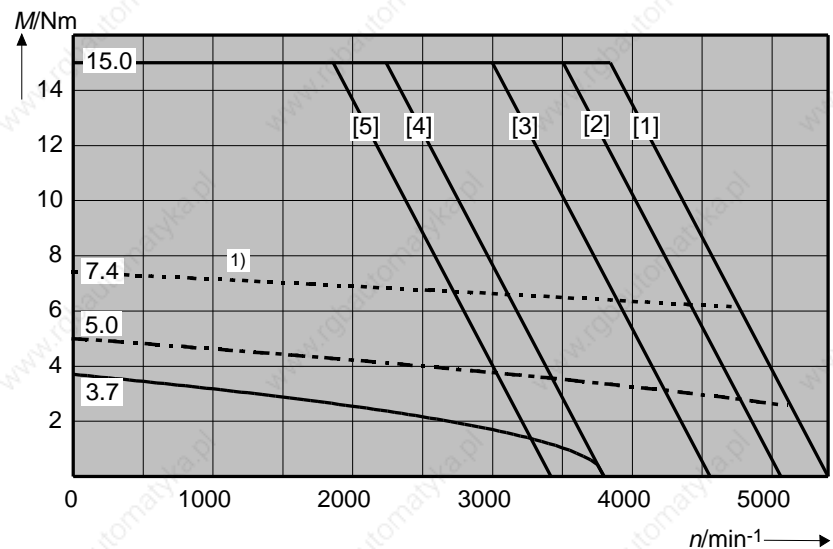

1) Shown: ON time of surface-cooled motor equals 45%.

Fig 8.4: Torque-speed characteristics curves - MDD 090

MDD 090 B at
2000 min⁻¹

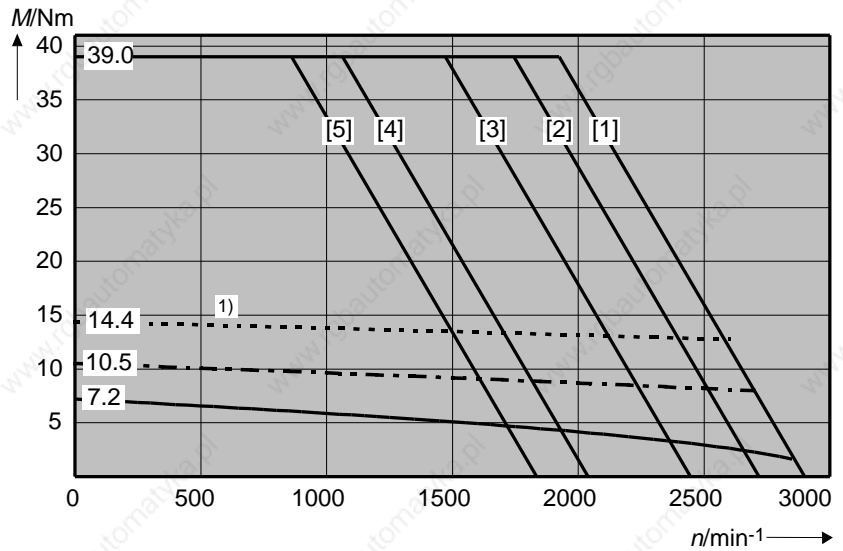

MDD 090 B at
3000 min⁻¹

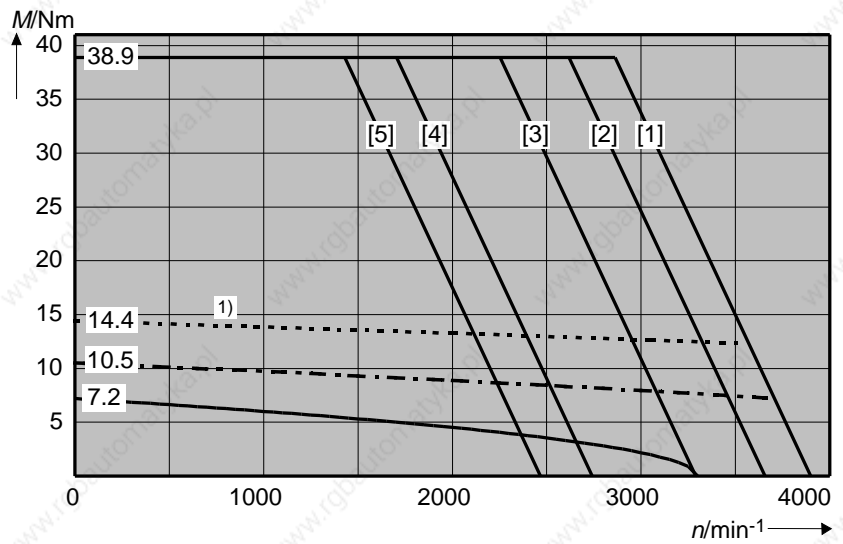

MDD 090 B at
4000 min⁻¹

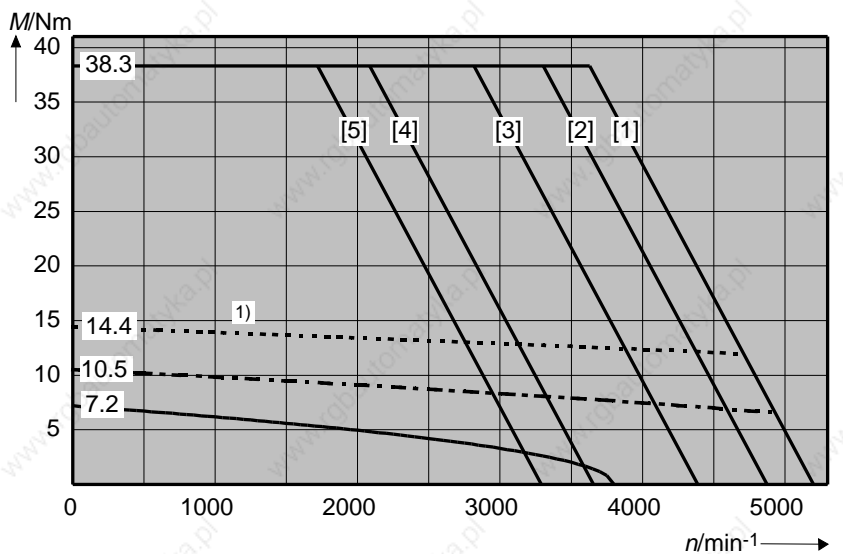

1) Shown: ON time of surface-cooled motor equals 53%.

Fig 8.5: Torque-speed characteristics curves - MDD 090

MDD 090 C at
2000 min⁻¹

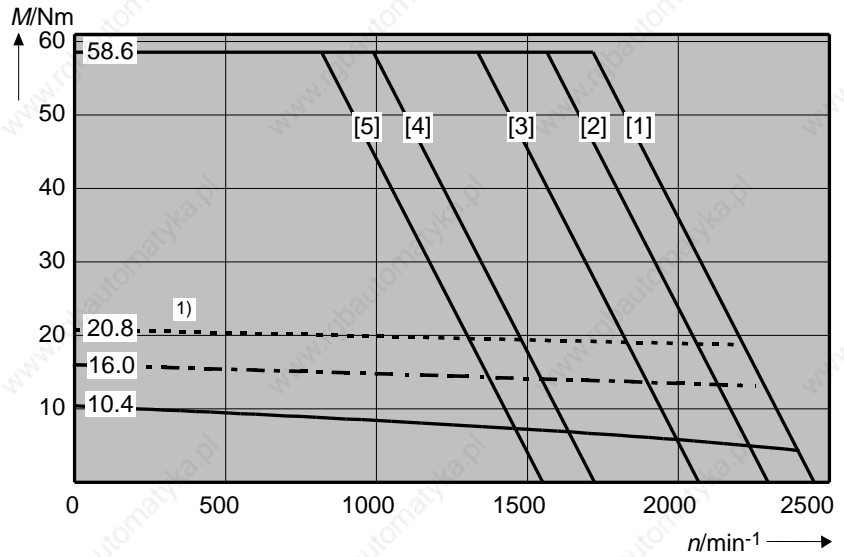

MDD 090 C at
3000 min⁻¹

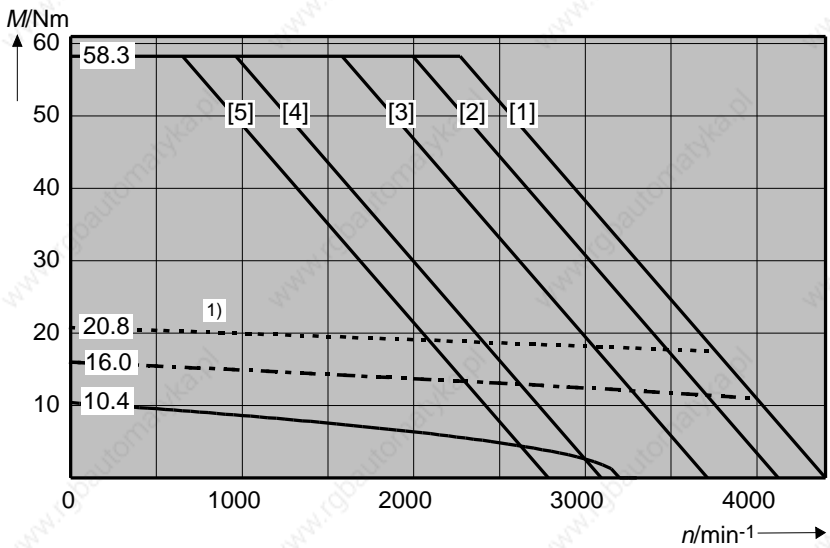

MDD 090 C at
4000 min⁻¹

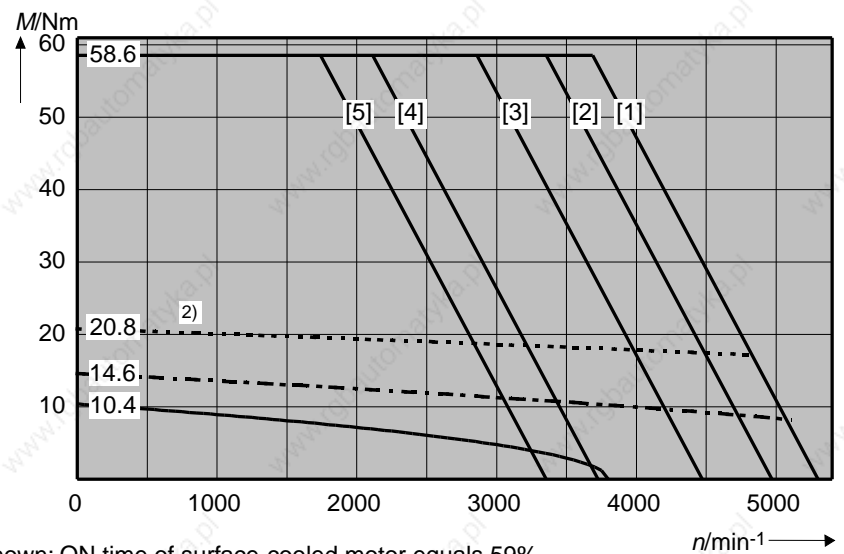

- 1) Shown: ON time of surface-cooled motor equals 59%.
- 2) Shown: ON time of surface-cooled motor equals 49%.

Fig 8.6: Torque-speed characteristics curves - MDD 090

8.3. Shaft Load Capacity

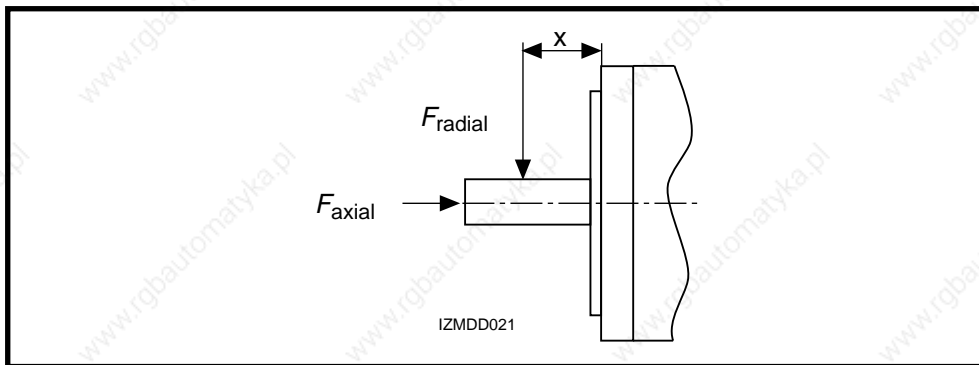

Fig 8.7: Shaft load

Permissible radial force
 F_{radial}

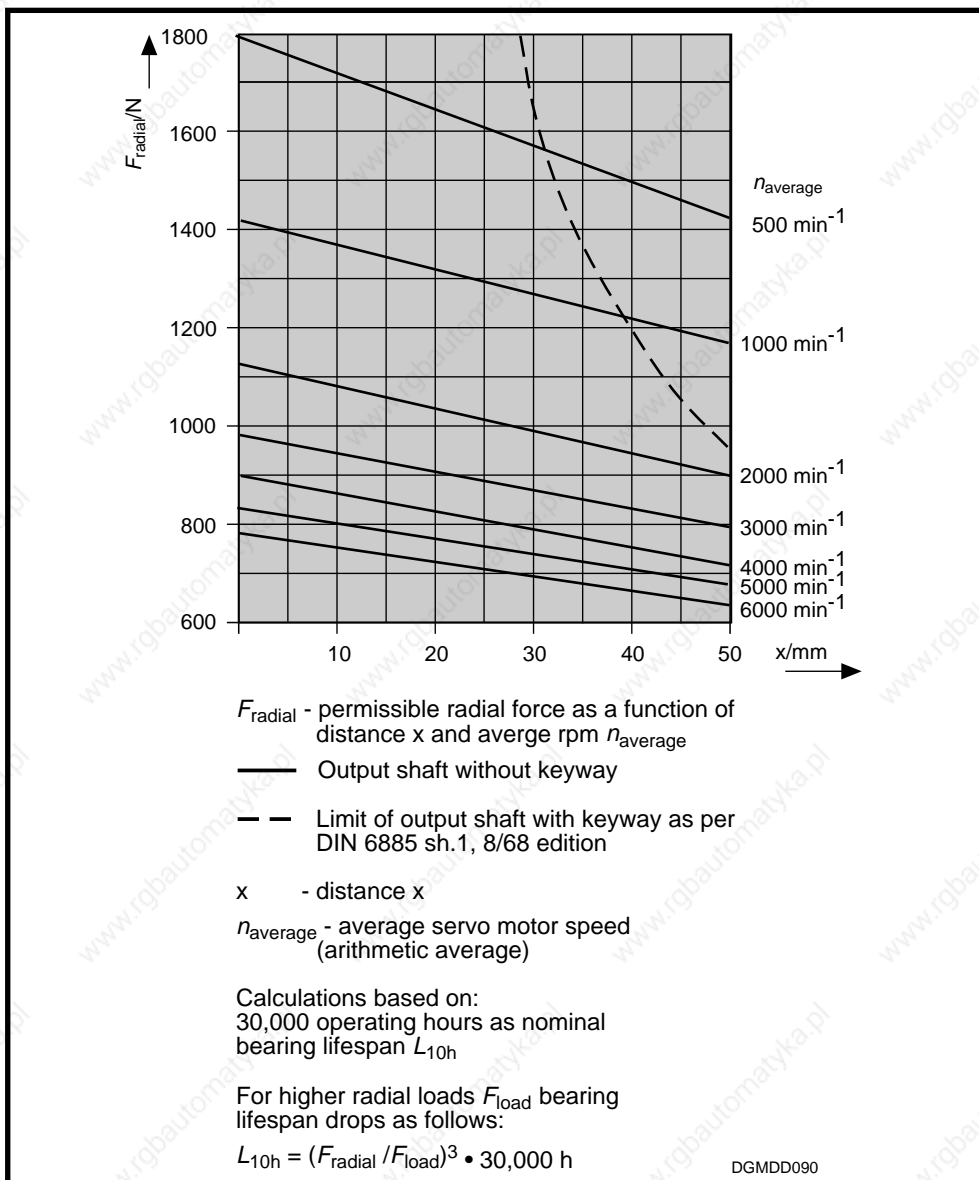

Fig 8.8: Permissible radial force

Permissible axial force
 F_{axial}

$$F_{axial} = 0.34 \cdot F_{radial}$$

F_{axial} - permissible axial force
 F_{radial} - permissible radial force

8.4. Dimensional Data

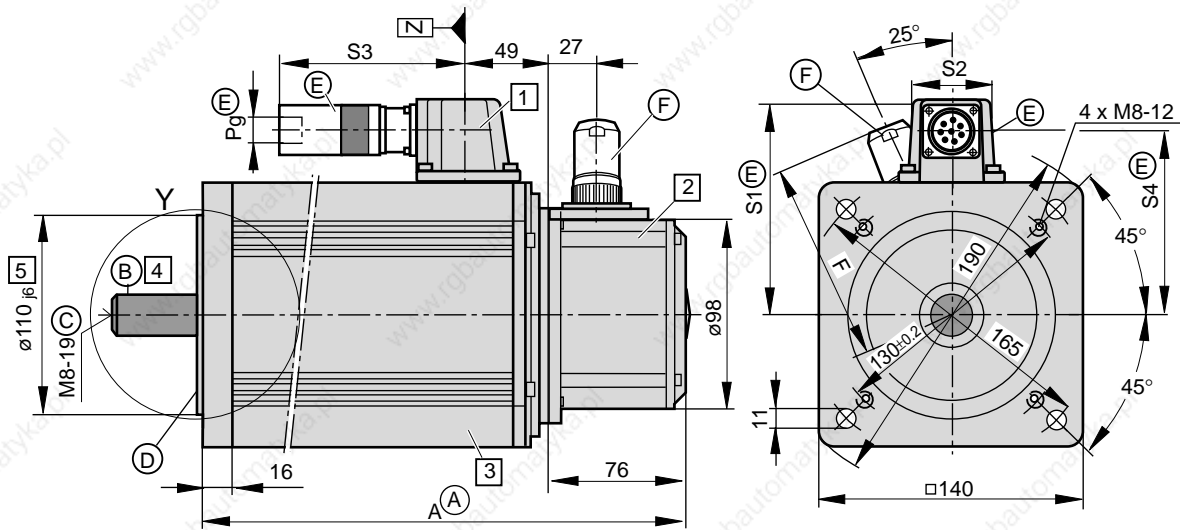

Detail Y

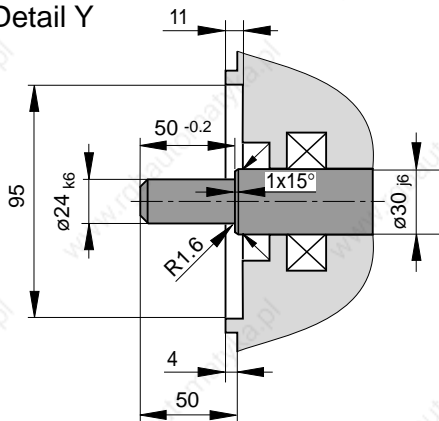

(A) Dimensional table Dim. A

Size	Dim. A 1)
MDD 090 A	275
MDD 090 B	340
MDD 090 C	405

1) Bigger with some options.
The then applicable dimension is indicated with the respective feature.

(B) Concentricity, excentricity and coaxiality to the shaft per DIN 42955, tolerance class R, 12/81 edition.

(C) • Shaft end per DIN 748 section 3, 7/75 edition, IEC 72, 1971 edition, cylindrical
• Center hole DS M3-8 per DIN 332 section 2, 5/83 edition
• Max. tightening torque M_A for screws in the threads of the center hole: 5 Nm
• Balance class N per DIN VDE 0530 section 14, 2/93 edition

(D) Flange type per DIN 42948, 11/65 edition, makes mounting possible
• as per design B5 (throughholes in flange)
• as per design B14 (threads in flange)

(E) **Motor power connector**
Depends on the motor, must be ordered separately.

Table of dimensions

type \ dim.	S1	S2	S3	S4	Pg
INS 252 2)	110	42	130	95	13,5
INS 108 3)	125	45	110	105	21

2) with MDD 090 A-N-020, MDD 090 A-N-030, MDD 090 A-N-040, MDD 090 B-N-020

3) other MDD 090

(F) **Feedback connector**
Must be ordered separately.

Table of dimensions

Name	Connector type	Dim. F
straight conn.	INS 513	110
	INS 512	112
angle conn.	INS 511 INS 510	108

MBMDD090_1

Fig 8.9: Dimensional data - MDD 090

Available Options

1 Power connection

The output direction of the electrical power connector is selected at the time the order is placed. Possible output direction is either:

- side A or
- side B
- to the right
- to the left

The drawing depicts side A as output direction. The dimensions of any other output direction are obtained by virtually turning the connector housing around the Z axis.

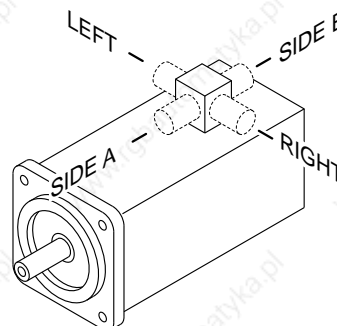

2 Motor feedback

- Digital servo feedback (DSF)
- Digital servo feedback (DSF) with integrated multiturn absolute encoder

The dimensions are identical.

3 Blocking brake

- without blocking brake
- with blocking brake: 6.5 Nm
- with blocking brake: 11 Nm

The dimensions are identical.

4 Output shaft

- plain shaft (preferred type)
- with keyway per DIN 6885 sheet 1, 8/68 edition
(Note: balanced with entire key!)

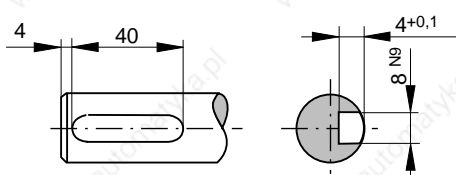

Matching key: DIN 6885-A 8 x 7 x 40

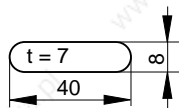

5 Special centering diameter

- $\varnothing 130_{j6}$

MBMDD090_2

Fig 8.10: Dimensional data - MDD 090 -available options

8.5. Available Versions

Type code field:	Example:	MDD	090	B	N	020	N	2	L	110	G	B	0
1. Name Motor for digital drive controllers	MDD												
2. Motor size	090												
3. Motor length	A, B, C												
4. Housing design: Standard (suited for natural convection and surface-cooling)	N												
5. Nominal speed 2000 min ⁻¹ 3000 min ⁻¹ 4000 min ⁻¹	020 030 040												
6. Balance class Standard (R per DIN VDE 0530 section 14, 2/93 edition)	N												
7. Side B shaft end Standard (without side B shaft end)	2												
8. Motor feedback digital servo feedback digital servo feedback with integrated multiturn absolute encoder	L M												
9. Centering diameter ø110 mm (Standard) ø130 mm	110 130												
10. Output shaft plain shaft shaft with keyway per DIN 6885 sh. 1, 8/68 edition	G P												
11. Power connection connector to side A connector to side B connector to the right (looking onto motor shaft, connecting housing at top) connector to the left (ooking onto motor shaft, connecting housing at top)	A B R L												
12. Blocking brake without blocking brake with 6.5 Nm blocking brake with 11.0 Nm blocking brake	0 1 2												

Quelle: INN 41.60 TLMD090

Fig 8.11: Type codes - MDD 090

9. MDD 093

9.1. Technical Data

Designation	Symbol	Unit	Motor type MDD ...				
			093 A-N-020	093 B-N-020	093 C-N-020	093 D-N-020	093 D-N-015
Nominal motor speed ¹⁾	n	min ⁻¹	2000	2000	2000	2000	1500
Continuous torque at standstill ²⁾	M_{dN}	Nm	9.2 (12.0) ⁵⁾	14.5(20.0) ⁵⁾	19.5(28.0) ⁵⁾	24.0(35.0) ⁵⁾	24.0(35.0) ⁵⁾
Continuous current at standstill	I_{dN}	A	10.2(13.3) ⁵⁾	16.9(23.3) ⁵⁾	21.4(30.8) ⁵⁾	31.2(45.5) ⁵⁾	24.7(36.1) ⁵⁾
Theor. maximum torque ³⁾	M_{max}	Nm	28.6	45.1	60.6	74.6	74.6
Peak current	I_{max}	A	45.8	76.0	96.5	140.4	111.2
Rotor moment of inertia ⁴⁾	J_M	kgm ²	22 x 10 ⁻⁴	29 x 10 ⁻⁴	42 x 10 ⁻⁴	58 x 10 ⁻⁴	58 x 10 ⁻⁴
Torque constant at 20 °C	K_m	Nm/A	0.90	0.86	0.91	0.77	0.97
Windings resistance at 20 °C	R_A	Ohm	1.86	0.77	0.56	0.42	0.5
Windings inductance	L_A	mH	15.3	7.6	6.1	3.9	5.7
Thermal time constant	T_{th}	min	50 (45) ⁵⁾	50 (45) ⁵⁾	50 (45) ⁵⁾	50 (45) ⁵⁾	50 (45) ⁵⁾
Mass ⁴⁾	m_M	kg	13.0	16.5	22.0	28.0	28.0
			093 A-N-030	093 B-N-030	093 C-N-030	093 C-L-030	093 D-N-030
Nominal motor speed ¹⁾	n	min ⁻¹	3000	3000	3000	3000	3000
Continuous torque at standstill ²⁾	M_{dN}	Nm	9.2 (12.0) ⁵⁾	14.5(20.0) ⁵⁾	19.5(20.8) ⁵⁾	19.5(28.0) ⁵⁾	24.0(35.0) ⁵⁾
Continuous current at standstill	I_{dN}	A	17.8(23.2) ⁵⁾	24.1(33.2) ⁵⁾	32.2(34.3) ⁵⁾	32.2(46.2) ⁵⁾	41.4(60.3) ⁵⁾
Theor. maximum torque ³⁾	M_{max}	Nm	28.6	45.1	60.6	60.6	74.6
Peak current	I_{max}	A	79.9	108.2	145.0	145.0	186.0
Rotor moment of inertia ⁴⁾	J_M	kgm ²	22 x 10 ⁻⁴	29 x 10 ⁻⁴	42 x 10 ⁻⁴	42 x 10 ⁻⁴	58 x 10 ⁻⁴
Torque constant at 20 °C	K_m	Nm/A	0.52	0.60	0.61	0.61	0.58
Windings resistance at 20 °C	R_A	Ohm	0.61	0.43	0.25	0.25	0.18
Windings inductance	L_A	mH	4.9	4.4	2.7	2.7	2.1
Thermal time constant	T_{th}	min	50 (45) ⁵⁾	50 (45) ⁵⁾	50 (45) ⁵⁾	50 (45) ⁵⁾	50 (45) ⁵⁾
Mass ⁴⁾	m_M	kg	13.0	16.5	22.0	22.0	28.0
			093 A-N-040	093 B-N-040	093 C-N-040	093 D-N-040	
Nominal motor speed ¹⁾	n	min ⁻¹	4000	4000	4000	4000	
Continuous torque at standstill ²⁾	M_{dN}	Nm	9.2 (12.0) ⁵⁾	14.5(20.0) ⁵⁾	19.5(28.0) ⁵⁾	24.0(35.0) ⁵⁾	
Continuous current at standstill	I_{dN}	A	23.3(30.4) ⁵⁾	36.6(50.5) ⁵⁾	45.3(65.0) ⁵⁾	63.2(92.1) ⁵⁾	
Theor. maximum torque ³⁾	M_{max}	Nm	28.6	45.1	60.6	74.6	
Peak current	I_{max}	A	104.8	164.8	204.0	284.0	
Rotor moment of inertia ⁴⁾	J_M	kgm ²	22 x 10 ⁻⁴	29 x 10 ⁻⁴	42 x 10 ⁻⁴	58 x 10 ⁻⁴	
Torque constant at 20 °C	K_m	Nm/A	0.39	0.40	0.43	0.38	
Windings resistance at 20 °C	R_A	Ohm	0.36	0.20	0.14	0.09	
Windings inductance	L_A	mH	2.8	1.9	1.6	1.3	
Thermal time constant	T_{th}	min	50 (45) ⁵⁾	50 (45) ⁵⁾	50 (45) ⁵⁾	50 (45) ⁵⁾	
Mass ⁴⁾	m_M	kg	13.0	16.5	22.0	28.0	

Continued on next page

¹⁾ Usable motor speed is determined by the torque requirements of the application. The usable speed n_{max} found in the selection lists of the motor-drive combinations are binding for **standard applications**. The usable speed for other applications can be found using the required torque in the torque-speed characteristics curves

²⁾ With 60 K overtemperature at the motor housing.

³⁾ Achievable maximum torque is dependent upon the drive used. **Only** those maximum torques M_{max} found in the selection list of the motor-drive combinations are binding.

⁴⁾ Without blocking brake, without blower

⁵⁾ Parenthetical values apply to motors with surface cooling.

Designation	Symbol	Unit	Motor type MDD ...		
			093 A-N-060	093 B-N-060	093 C-N-060
Nominal motor speed ¹⁾	n	min ⁻¹	6000	6000	6000
Continuous torque at standstill ²⁾	M_{dN}	Nm	9.2 (12.0) ⁵⁾	14.5 (20.0) ⁵⁾	19.5 (28.0) ⁵⁾
Continuous current at standstill	I_{dN}	A	36.8 (48.0) ⁵⁾	46.7 (64.5) ⁵⁾	65.2 (93.6) ⁵⁾
Theor. maximum torque ³⁾	M_{max}	Nm	28.6	45.1	60.6
Peak current	I_{max}	A	165.8	210.3	293.3
Rotor moment of inertia ⁴⁾	J_M	kgm ²	22 x 10 ⁻⁴	29 x 10 ⁻⁴	42 x 10 ⁻⁴
Torque constant at 20 °C	K_m	Nm/A	0.25	0.31	0.30
Windings resistance at 20 °C	R_A	Ohm	0.16	0.11	0.07
Windings inductance	L_A	mH	1.3	1.1	0.7
Thermal time constant	T_{th}	min	50 (45) ⁵⁾	50 (45) ⁵⁾	50 (45) ⁵⁾
Mass ⁴⁾	m_M	kg	13.0	16.5	22.0

¹⁾ Usable motor speed is determined by the torque requirements of the application. The usable speed n_{max} found in the selection lists of the motor-drive combinations are binding for **standard applications**. The usable speed for other applications can be found using the required torque in the torque-speed characteristics curves
²⁾ With 60 K overtemperature at the motor housing.
³⁾ Achievable maximum torque is dependent upon the drive used. **Only** those maximum torques M_{max} found in the selection list of the motor-drive combinations are binding.
⁴⁾ Without blocking brake, without blower
⁵⁾ Parenthetical values apply to motors with surface cooling.

Fig 9.1: Type dependent motor data

Designation	Symbol	Unit	Data
Permissible ambient temp.	T_{um}	°C	0 ... + 45
Permissible storage and transport temperature	T_L	°C	-20 ... + 80
Maximum installation elevation		m	1000 meters above sea level
Protection category			IP 65
Insulation classification			F
Housing coat			Black prime coat (RAL 9005)

Fig 9.2: General data - MDD 093

Designation	Symbol	Unit	Data Blocking Brake	
Principle of action			electrically- actuated release	
Holding torque	M_H	Nm	11	22
Nominal voltage	U_N	V	DC 24 ± 10%	DC 24 ± 10%
Nominal current	I_N	A	0.5	0.7
Moment of inertia	J_B	kgm ²	1.06 x 10 ⁻⁴	3.6 x 10 ⁻⁴
Release delay	t_L	ms	60	70
Clamping delay	t_K	ms	20	30
Mass	m_B	kg	0.5	1.1

Fig 9.3: Technical data - blocking brake

9.2. Torque-Speed Characteristics

MDD 093 A-N at
2000 min⁻¹

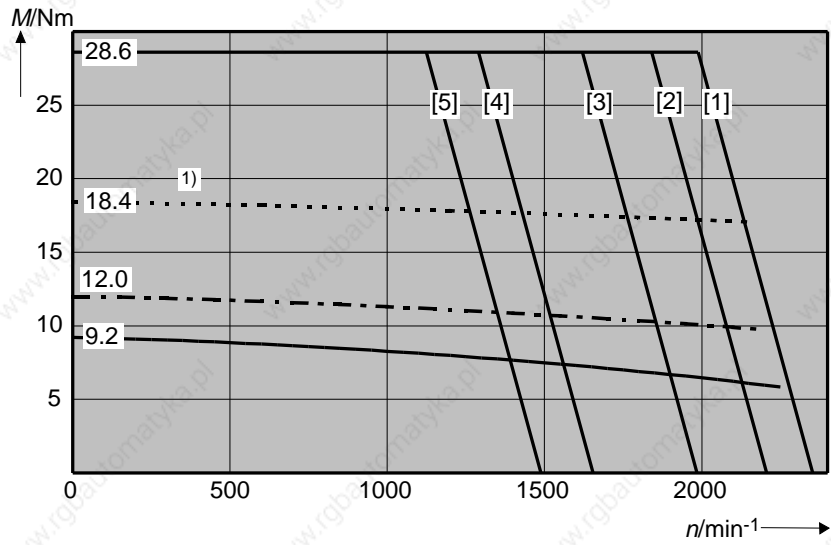

MDD 093 A-N at
3000 min⁻¹

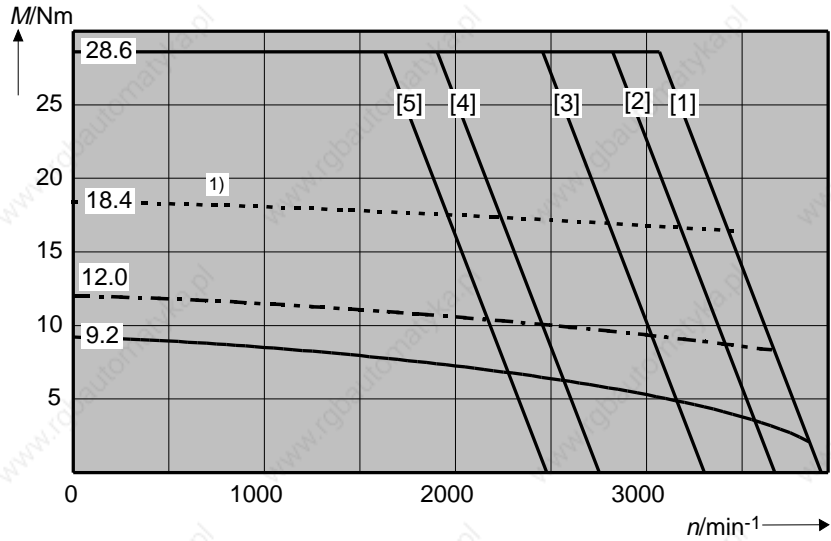

MDD 093 A-N at
4000 min⁻¹

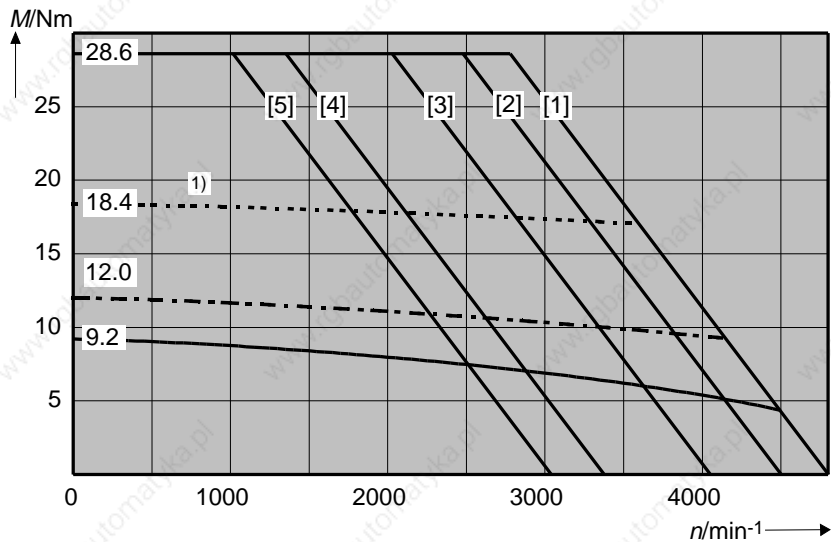

1) Shown: ON time of surface-cooled motor equals 42%

Fig 9.4: Torque-speed characteristics curve - surface MDD 093

MDD 093 A-N at
6000 min⁻¹

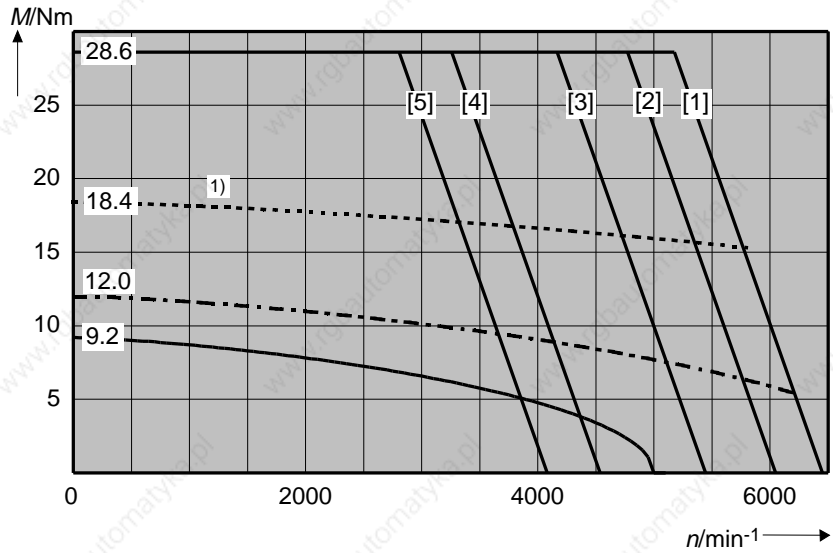

MDD 093 B-N at
2000 min⁻¹

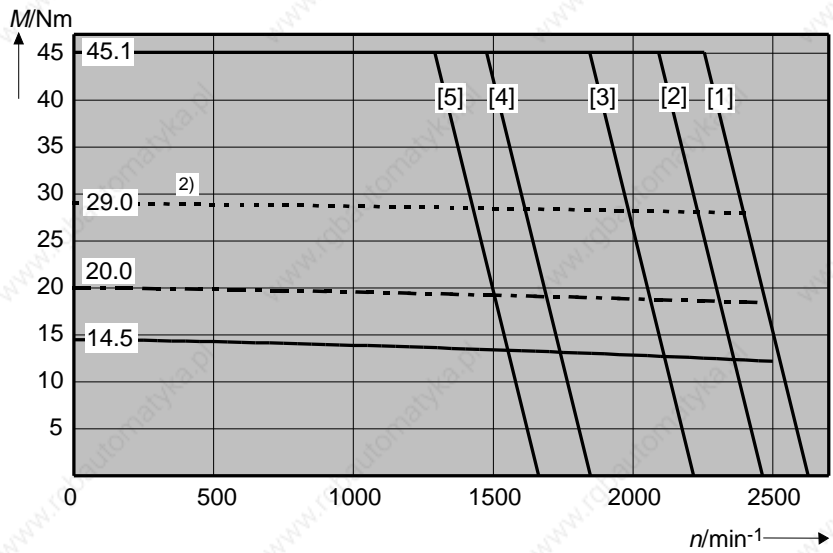

MDD 093 B-N at
3000 min⁻¹

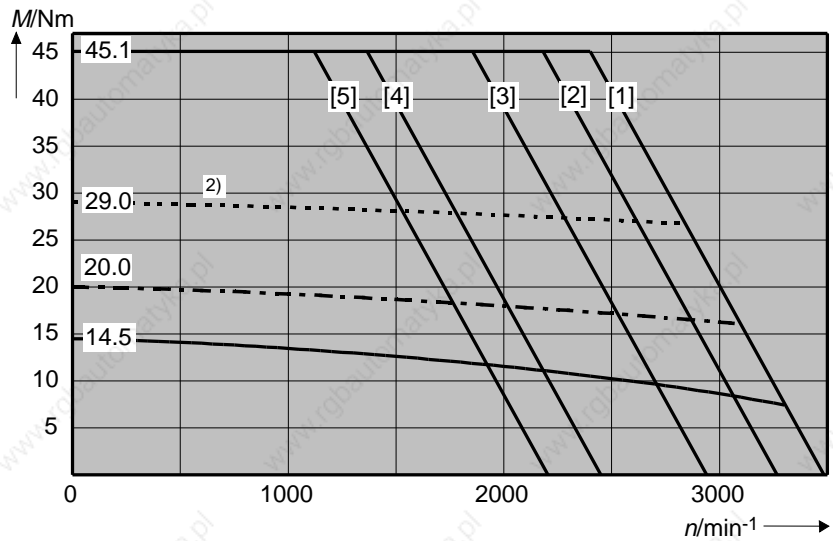

- 1) Shown: ON time of surface-cooled motor equals 42%.
- 2) Shown: ON time of surface-cooled motor equals 48%.

Fig 9.5: Torque-speed characteristics curve - MDD 093

MDD 093 B-N at
4000 min⁻¹

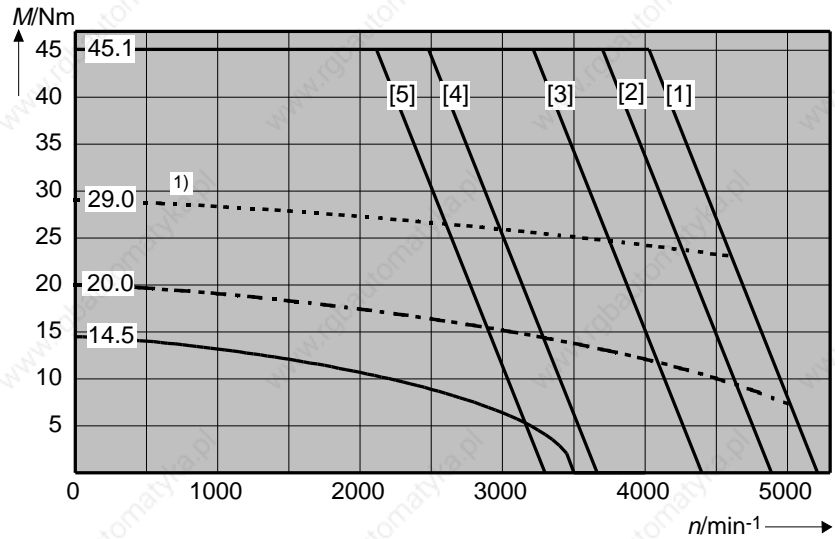

MDD 093 B-N at
6000 min⁻¹

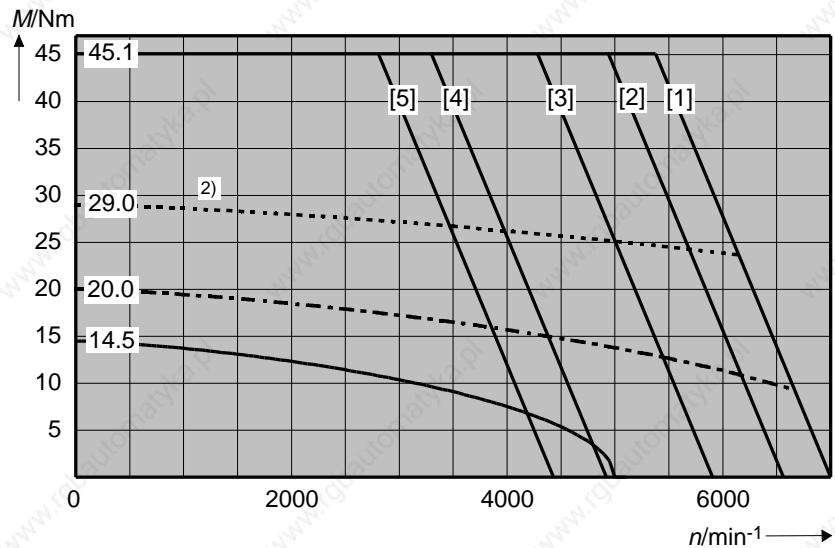

MDD 093 C-N at
2000 min⁻¹

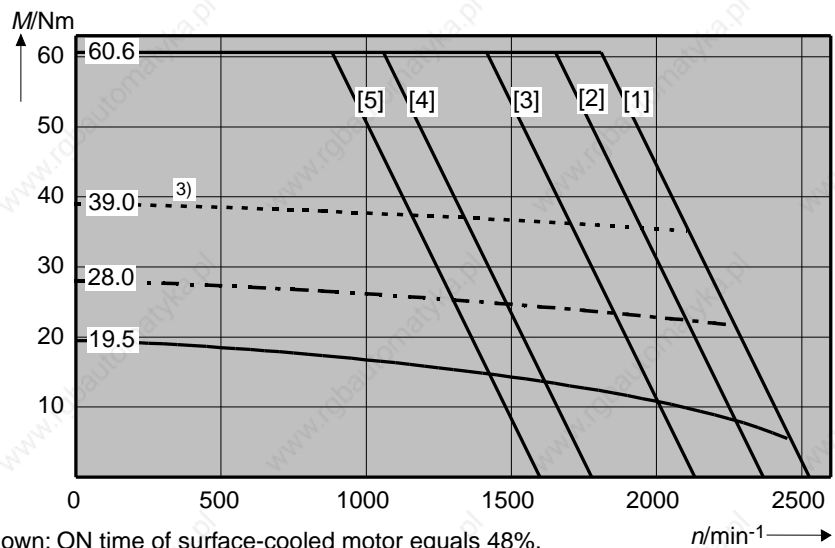

- 1) Shown: ON time of surface-cooled motor equals 48%.
- 2) Shown: ON time of surface-cooled motor equals 46%.
- 3) Shown: ON time of surface-cooled motor equals 52%.

Fig 9.6: Torque-speed characteristics curve - MDD 093

MDD 093 C-N at
3000 min⁻¹

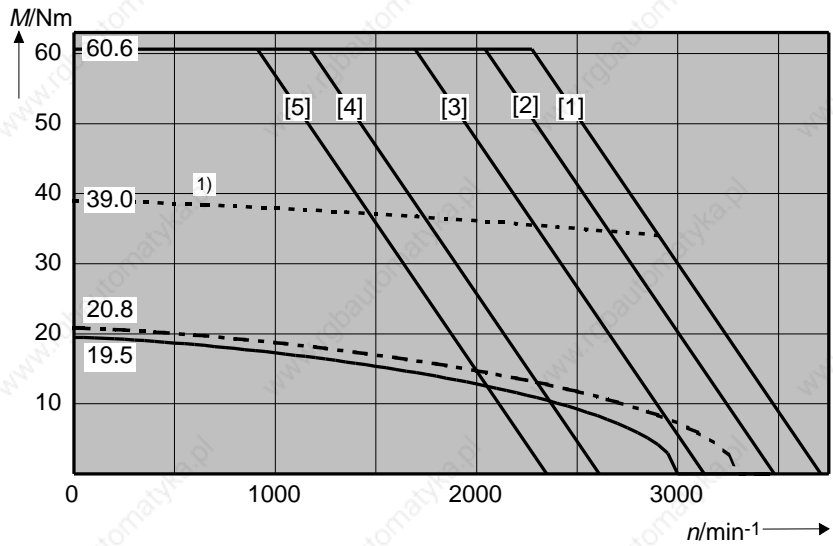

MDD 093 C-L at
3000 min⁻¹

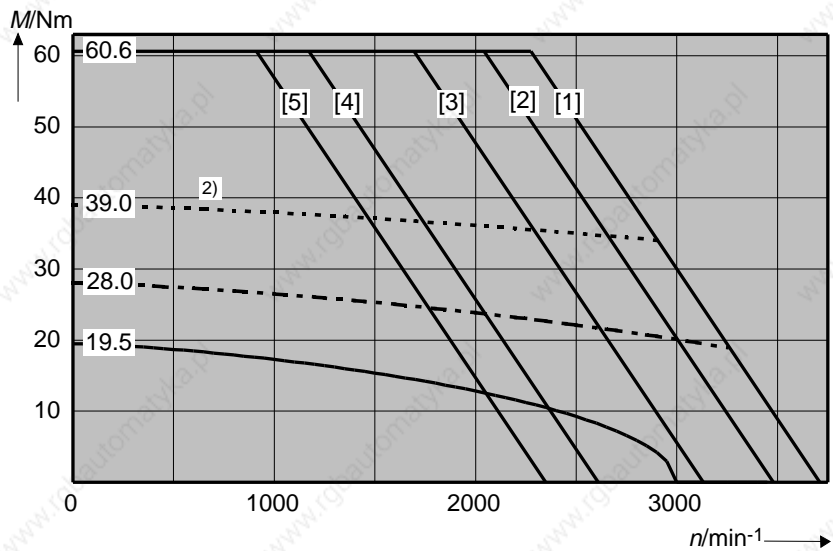

MDD 093 C-N at
4000 min⁻¹

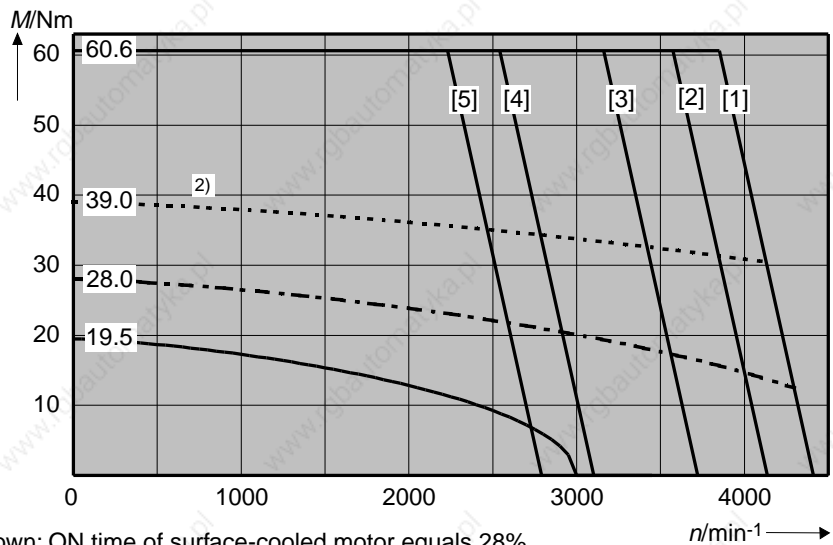

- 1) Shown: ON time of surface-cooled motor equals 28%.
- 2) Shown: ON time of surface-cooled motor equals 52%.

Fig 9.7: Torque-speed characteristics curve - MDD 093

MDD 093 C-N at
6000 min⁻¹

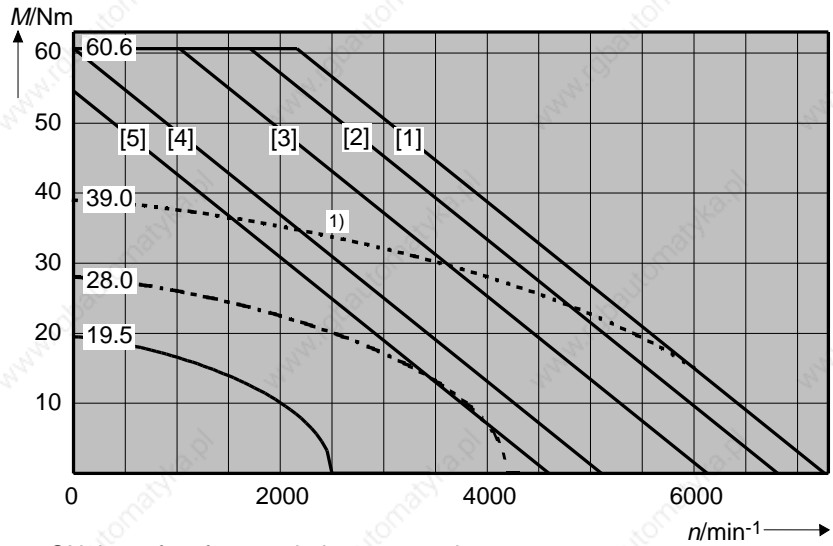

1) Shown: ON time of surface-cooled motor equals 52%.

MDD 093 D-N at
1500 min⁻¹

in preparation

MDD 093 D-N at
2000 min⁻¹

in preparation

Fig 9.8: Torque-speed characteristics curve - MDD 093

*MDD 093 D-N at
3000 min⁻¹*

in preparation

*MDD 093 D-N at
4000 min⁻¹*

in preparation

Fig 9.9: Torque-speed characteristics curve - MDD 093

9.3. Shaft Load Capacity

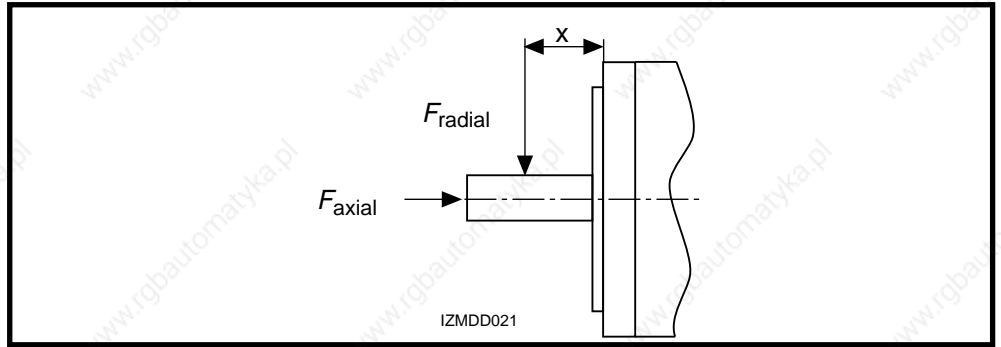

Fig 9.10: Shaft load

Permissible radial force
 F_{radial}

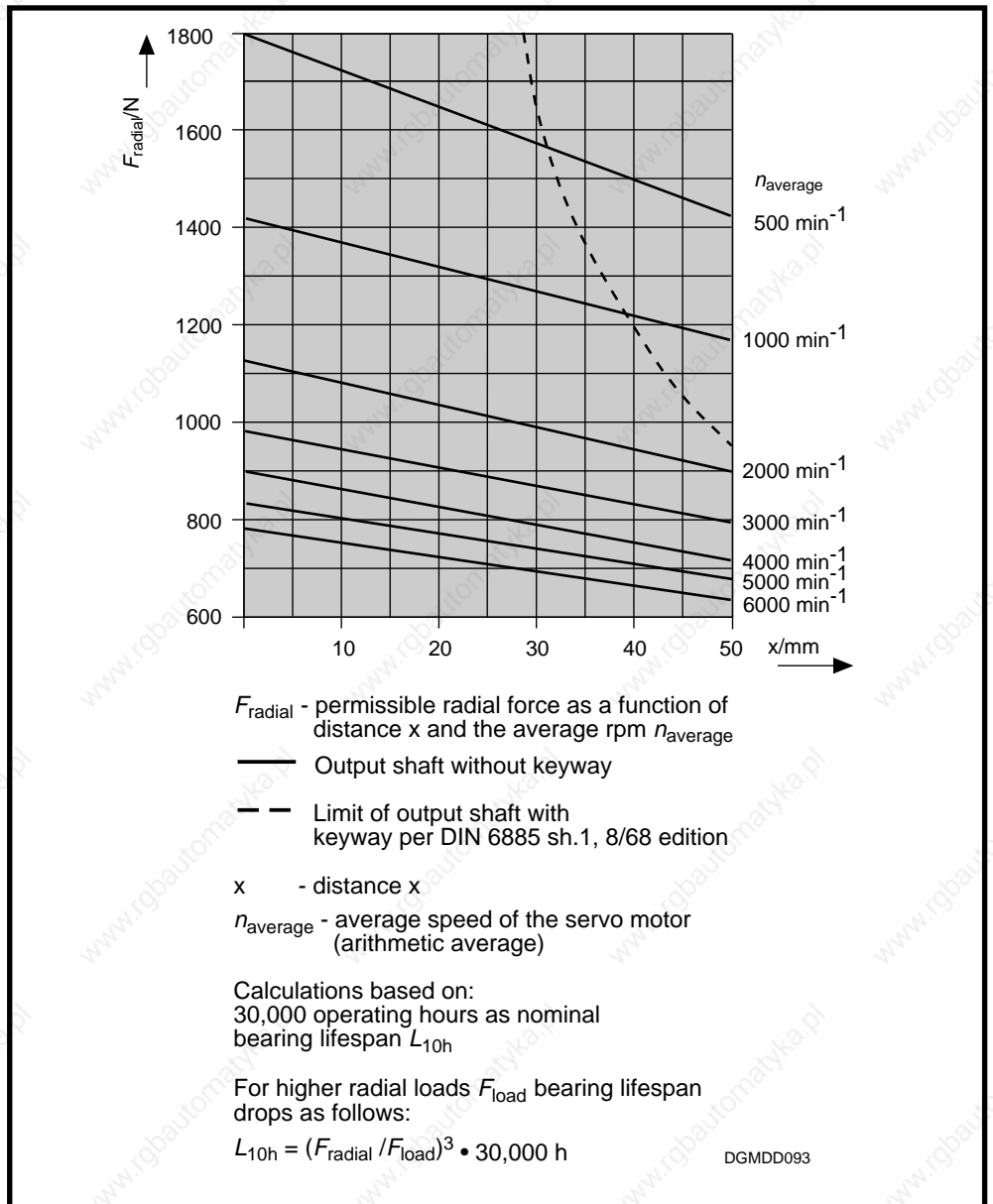

Fig 9.11: Permissible radial force

Permissible axial force
 F_{axial}

$$F_{axial} = 0.34 \cdot F_{radial}$$

F_{axial} - permissible axial force
 F_{radial} - permissible radial force

9.4. Dimensional Data

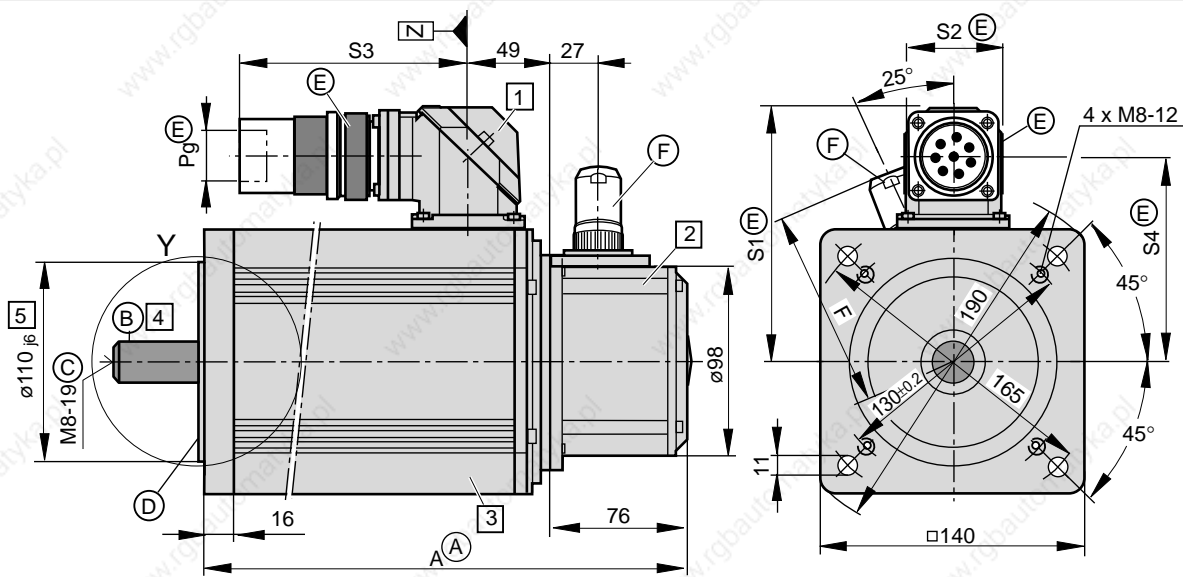

Detail Y

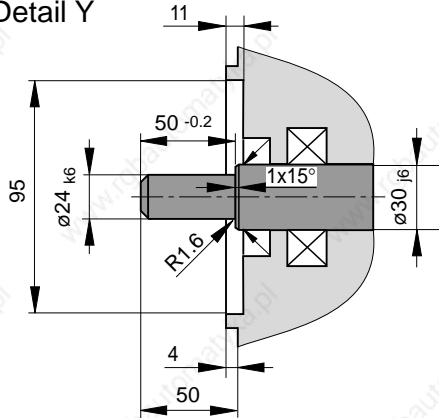

(A) Dimensional table Dim. A

Size	Dim. A 1)
MDD 093 A	286
MDD 093 B	327
MDD 093 C	386
MDD 093 D	436

1) Bigger with some options.
The then valid dimensions is indicated with the respective feature.

(B) Concentricity, excentricity and coaxiality to the shaft per DIN 42955, tolerance class R, 12/81 edition.

(C) • Shaft end per DIN 748 section 3, 7/75 edition, IEC 72, 1971 edition, cylindrical
• Center hole DS M3-8 per DIN 332 section 2, 5/83 edition
• Max. tightening torque M_A for screws in the threads of the center hole: 5 Nm
• Balance class N per DIN VDE 0530 section 14, 2/93 edition

(D) Flange type per DIN 42948, 11/65 edition, makes mounting possible
• as per design B5 (throughhole in flange)
• as per design B14 (threads in flange)

(E) **Motor power connector**
Depends on motor, must be ordered separately.

Table of dimensions

dim type	S1	S2	S3	S4	Pg
INS 108 2)	125	45	110	105	21
INS 172 3)	135	53	145	108	36

2) with MDD 093 A-N-020, MDD 093 A-N-030, MDD 093 A-N-040, MDD 093 B-N-020, MDD 093 B-N-030, MDD 093 C-N-020, MDD 093 C-N-030

3) other MDD 093

(F) **Feedback connector**

Must be ordered separately.

Table of dimensions

Name	Connector type	Dim. F
straight conn.	INS 513	110
	INS 512	112
angle conn.	INS 511 INS 510	108

MBMDD093_1

Fig 9.12: Dimensional data MDD 093

Available Options

1 Power connection

The output direction of the electrical power connector is selected at the time the order is placed. Possible output direction is either:

- side A or
- side B
- to the right
- to the left

The drawing depicts side A as output direction. The dimensions of any other output direction are obtained by virtually turning the connector housing around the Z axis.

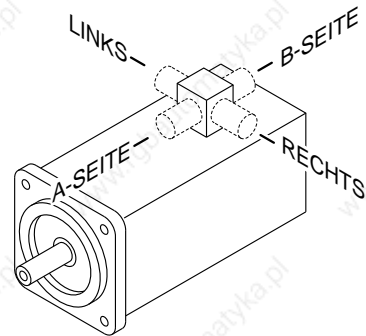

2 Motor feedback

- Digital servo feedback (DSF)
- Digital servo feedback (DSF) with integrated multiturn absolute encoder

The dimensions are identical.

3 Blocking brake

- without blocking brake
- with blocking brake: 11 Nm } The dimensions are identical.
- with blocking brake: 22 Nm

Dimensional table for motors with blocking brake: 22 Nm

Size	Dim. A
MDD 093 A	316
MDD 093 B	357
MDD 093 C	416
MDD 093 D	466

4 Output shaft

- plain shaft (preferred type)
- with keyway per DIN 6885 sheet 1, 8/68 edition
(Note: balanced with entire key!)

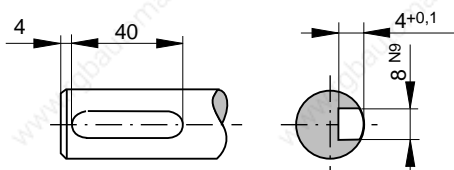

Matching key: DIN 6885-A 8 x 7 x 40

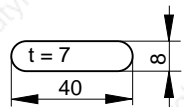

5 Special centering diameter

- $\varnothing 130_{j6}$

MBMDD093_2

Fig 9.13: Dimensional data MDD 093 - available options

9.5. Available Versions

Type code field:	Example:	MDD	093	B	N	020	N	2	L	110	G	B	0
1. Name Motor for digital drive controllers	MDD												
2. Motor size	093												
3. Motor lengths	A, B, C, D												
4. Housing design: Standard (suited for natural convection and surface-cooling) for surface cooling with motors requiring a bigger power connector with housing design N	N L 1)												
5. Nominal speed 1500 min ⁻¹ 2000 min ⁻¹ 3000 min ⁻¹ 4000 min ⁻¹ 6000 min ⁻¹	015 2) 020 030 040 060 3)												
6. Balance class Standard (R per DIN VDE 0530 section 14, 2/93 edition)	N												
7. Side B shaft end Standard (without side B shaft end)	2												
8. Motor feedback digital servo feedback digital servo feedback with integrated multiturn absolute encoder	L M												
9. Centering diameter ø110 mm (standard) ø130 mm	110 130												
10. Output shaft plain shaft shaft with keyway per DIN 6885 sh. 1, 8/68 edition	G P												
11. Power connection connector to side A connector to side B connector to the right (looking onto motor shaft, connecting housing at top) connector to the left (looking onto motor shaft, connecting housing at top)	A B R L												
12. Blocking brake without blocking brake with 11.0 Nm blocking brake with 22.0 Nm blocking brake	0 1 2												

1) Housing design "L" only with motor types MDD 093C-L-030.
2) Only with motor length "D"
3) Only with motor length "D"

Quelle: INN 41.60 TLMD093

Fig 9.14: Type codes - MDD 093

Empty Page

10. MDD 112

10.1. Technical Data

Designation	Symbol	Unit	Motor type MDD ...				
			112 A-N-015	112 B-N-015	112 C-N-015	112 D-N-015	112 D-L-015
Nominal motor speed ¹⁾	n	min ⁻¹	1500	1500	1500	1500	1500
Continuous torque at standstill ²⁾	M_{dN}	Nm	10.5(13.0) ⁵⁾	17.5(29.0) ⁵⁾	28.0(43.2) ⁵⁾	38.0(44.0) ⁵⁾	38.0(57.0) ⁵⁾
Continuous current at standstill	I_{dN}	A	8.3 (10.3) ⁵⁾	14.0(23.1) ⁵⁾	22.2(34.3) ⁵⁾	29.7(34.3) ⁵⁾	29.7(44.5) ⁵⁾
Theor. maximum torque ³⁾	M_{max}	Nm	31.4	60.5	97.2	132.4	132.4
Peak current	I_{max}	A	26.7	55.3	82.6	110.5	110.5
Rotor moment of inertia ⁴⁾	J_M	kgm ²	61 x 10 ⁻⁴	120 x 10 ⁻⁴	170 x 10 ⁻⁴	230 x 10 ⁻⁴	230 x 10 ⁻⁴
Torque constant at 20 °C	K_m	Nm/A	1.26	1.25	1.26	1.28	1.28
Windings resistance at 20 °C	R_A	Ohm	2.94	0.85	0.56	0.39	0.39
Windings inductance	L_A	mH	32	13	7.9	5.9	5.9
Thermal time constant	T_{th}	min	100 (75) ⁵⁾	90 (60) ⁵⁾	100 (75) ⁵⁾	120 (90) ⁵⁾	120 (90) ⁵⁾
Mass ⁴⁾	m_M	kg	25	36	48	59	59
			112 A-N-020	112 B-N-020	112 C-N-020	112 C-L-020	112 D-N-020
Nominal motor speed ¹⁾	n	min ⁻¹	2000	2000	2000	2000	2000
Continuous torque at standstill ²⁾	M_{dN}	Nm	10.5(13.0) ⁵⁾	17.5(28.9) ⁵⁾	28.0(32.3) ⁵⁾	28.0(44.0) ⁵⁾	38.0(57.0) ⁵⁾
Continuous current at standstill	I_{dN}	A	11.8(14.6) ⁵⁾	20.7(34.3) ⁵⁾	29.7(34.3) ⁵⁾	29.7(46.8) ⁵⁾	43.8(65.8) ⁵⁾
Theor. maximum torque ³⁾	M_{max}	Nm	30.7	65.1	97.3	97.3	134.8
Peak current	I_{max}	A	37.0	82.6	110.5	110.5	166.4
Rotor moment of inertia ⁴⁾	J_M	kgm ²	61 x 10 ⁻⁴	120 x 10 ⁻⁴	170 x 10 ⁻⁴	170 x 10 ⁻⁴	230 x 10 ⁻⁴
Torque constant at 20 °C	K_m	Nm/A	0.89	0.84	0.94	0.94	0.87
Windings resistance at 20 °C	R_A	Ohm	1.40	0.43	0.31	0.31	0.18
Windings inductance	L_A	mH	16	5.7	5.0	5.0	2.7
Thermal time constant	T_{th}	min	100 (75) ⁵⁾	90 (60) ⁵⁾	100 (75) ⁵⁾	100 (75) ⁵⁾	120 (90) ⁵⁾
Mass ⁴⁾	m_M	kg	25	36	48	48	59
			112 A-N-030	112 B-N-030	112 B-L-030	112 C-N-030	112 D-N-030
Nominal motor speed ¹⁾	n	min ⁻¹	3000	3000	3000	3000	3000
Continuous torque at standstill ²⁾	M_{dN}	Nm	10.5(13.0) ⁵⁾	17.5(21.4) ⁵⁾	17.5(29.0) ⁵⁾	28.0(44.0) ⁵⁾	38.0(57.0) ⁵⁾
Continuous current at standstill	I_{dN}	A	17.3(21.4) ⁵⁾	28.0(34.3) ⁵⁾	28.0(46.4) ⁵⁾	43.4(68.1) ⁵⁾	60.6(90.9) ⁵⁾
Theor. maximum torque ³⁾	M_{max}	Nm	31.3	64.5	64.5	100.4	130.2
Peak current	I_{max}	A	55.3	110.5	110.5	166.4	222.2
Rotor moment of inertia ⁴⁾	J_M	kgm ²	61 x 10 ⁻⁴	120 x 10 ⁻⁴	120 x 10 ⁻⁴	170 x 10 ⁻⁴	230 x 10 ⁻⁴
Torque constant at 20 °C	K_m	Nm/A	0.61	0.62	0.62	0.65	0.63
Windings resistance at 20 °C	R_A	Ohm	0.66	0.25	0.25	0.14	0.10
Windings inductance	L_A	mH	6.8	3.1	3.1	2.0	1.5
Thermal time constant	T_{th}	min	100 (75) ⁵⁾	90 (60) ⁵⁾	90 (60) ⁵⁾	100 (75) ⁵⁾	120 (90) ⁵⁾
Mass ⁴⁾	m_M	kg	25	36	36	48	59

Continued on next page

¹⁾ Usable motor speed is determined by the torque requirements of the application. The usable speed n_{max} found in the selection lists of the motor-drive combinations are binding for **standard applications**. The usable speed for other applications can be found using the required torque in the torque-speed characteristics curves

²⁾ With 60 K overtemperature at the motor housing.

³⁾ Achievable maximum torque is dependent upon the drive used. **Only** those maximum torques M_{max} found in the selection list of the motor-drive combinations are binding.

⁴⁾ Without blocking brake, without blower

⁵⁾ Parenthetical values apply to motors with surface cooling.

Designation	Symbol	Unit	Motor type MDD ...				
			112 A-N-040	112 B-N-040	112 C-N-040	112 D-N-040	112 C-N-060
Nominal motor speed ¹⁾	n	min ⁻¹	4000	4000	4000	4000	6000
Continuous torque at standstill ²⁾	M_{dN}	Nm	10.5(13.0) ⁵⁾	17.5(29.0) ⁵⁾	28.0(44.0) ⁵⁾	38.0(44.2) ⁵⁾	28.0(32.9) ⁵⁾
Continuous current at standstill	I_{dN}	A	23.0(28.4) ⁵⁾	41.5(68.8) ⁵⁾	58.1(91.3) ⁵⁾	88.4(102.9) ⁵⁾	87.5(102.9) ⁵⁾
Theor. maximum torque ³⁾	M_{max}	Nm	31.3	65.5	100.1	132.2	77.0
Peak current	I_{max}	A	72.9	166.4	222.2	329.1	257.4
Rotor moment of inertia ⁴⁾	J_M	kgm ²	61 x 10 ⁻⁴	120 x 10 ⁻⁴	170 x 10 ⁻⁴	230 x 10 ⁻⁴	170 x 10 ⁻⁴
Torque constant at 20 °C	K_m	Nm/A	0.46	0.42	0.48	0.43	0.32
Windings resistance at 20 °C	R_A	Ohm	0.38	0.11	0.08	0.05	0.04
Windings inductance	L_A	mH	4.0	1.5	0.9	0.7	0.5
Thermal time constant	T_{th}	min	100 (75) ⁵⁾	90 (60) ⁵⁾	100 (75) ⁵⁾	120 (90) ⁵⁾	100 (75) ⁵⁾
Mass ⁴⁾	m_M	kg	25	36	48	59	48

1) Usable motor speed is determined by the torque requirements of the application. The usable speed n_{max} found in the selection lists of the motor-drive combinations are binding for **standard applications**. The usable speed for other applications can be found using the required torque in the torque-speed characteristics curves

2) With 60 K overtemperature at the motor housing.

3) Achievable maximum torque is dependent upon the drive used. **Only** those maximum torques M_{max} found in the selection list of the motor-drive combinations are binding.

4) Without blocking brake, without blower

5) Parenthetical values apply to motors with surface cooling.

Fig 10.1: Type dependent motor data

Designation	Symbol	Unit	Data
Permissible ambient temperature	T_{um}	°C	0 ... + 45
Permissible storage and transport temperature	T_L	°C	-20 ... + 80
Maximum installation elevation		m	1000 meters above sea level
Protection category			IP 65
Insulation classification			F
Housing coat			Black prime coat (RAL 9005)

Fig 10.2: General data - MDD 112

Designation	Symbol	Unit	Data Blocking Brake		
Principle of action			electrically actuated release		
Blocking brake	M_H	Nm	144,060		
Nominal voltage	U_N	V	DC 24 ± 10%	DC 24 ± 10%	DC 24 ± 10%
Nominal current	I_N	A	0.75	1.35	1.35
Moment of inertia	J_B	kgm ²	3.6 x 10 ⁻⁴	32 x 10 ⁻⁴	32 x 10 ⁻⁴
Release delay	t_L	ms	70	150	150
Clamping delay	t_K	ms	30	30	30
Mass	m_B	kg	1.1	3.5	3.5

Fig 10.3: Technical data - blocking brake

10.2. Torque-Speed Characteristics

MDD 112 A-N at
1500 min⁻¹

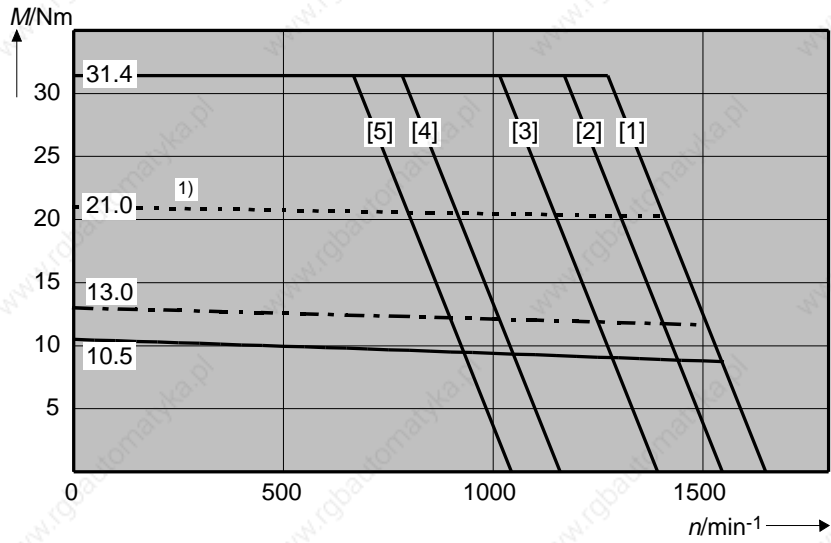

MDD 112 A-N at
2000 min⁻¹

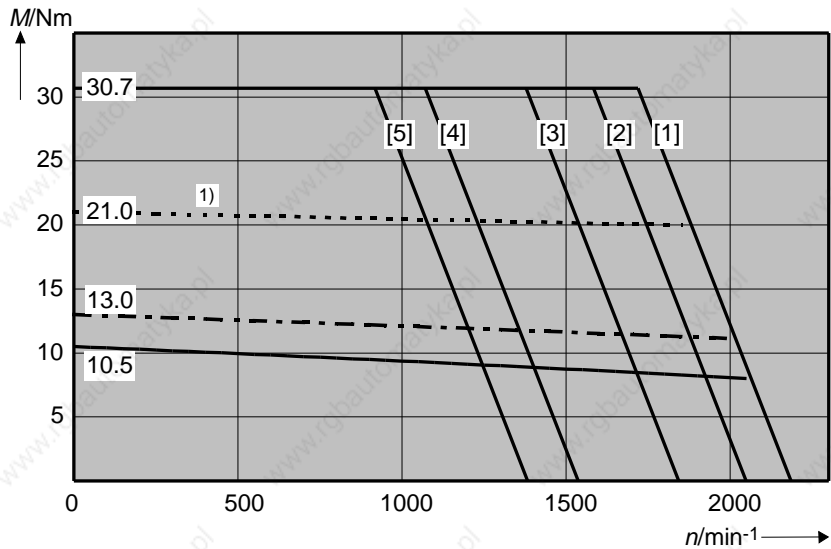

MDD 112 A-N at
3000 min⁻¹

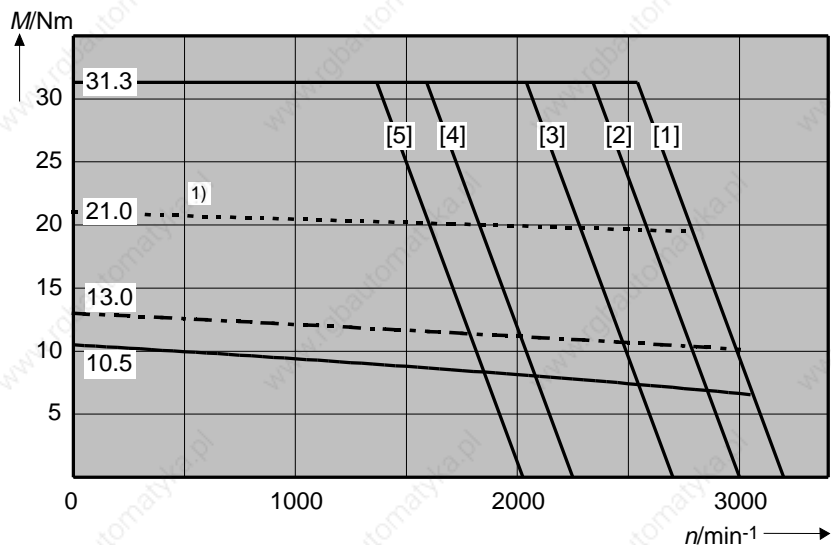

1) Shown: ON time of surface-cooled motor equals 38%.

Fig 10.4: Torque-speed characteristics curve MDD 112

MDD 112 A-N at
4000 min⁻¹

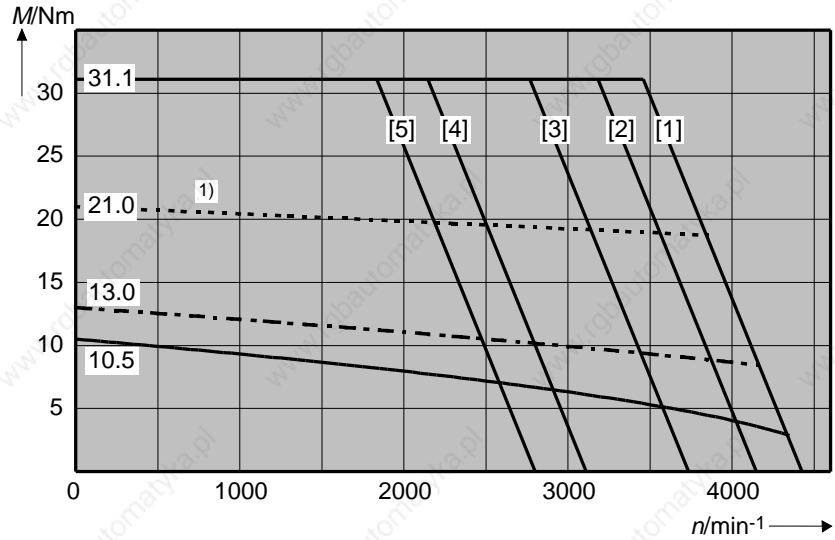

MDD 112 B-N at
1500 min⁻¹

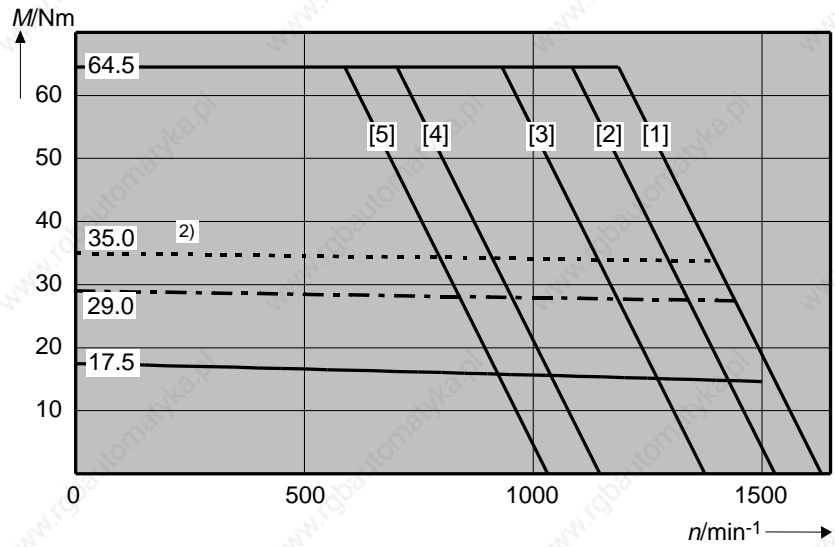

MDD 112 B-N at
2000 min⁻¹

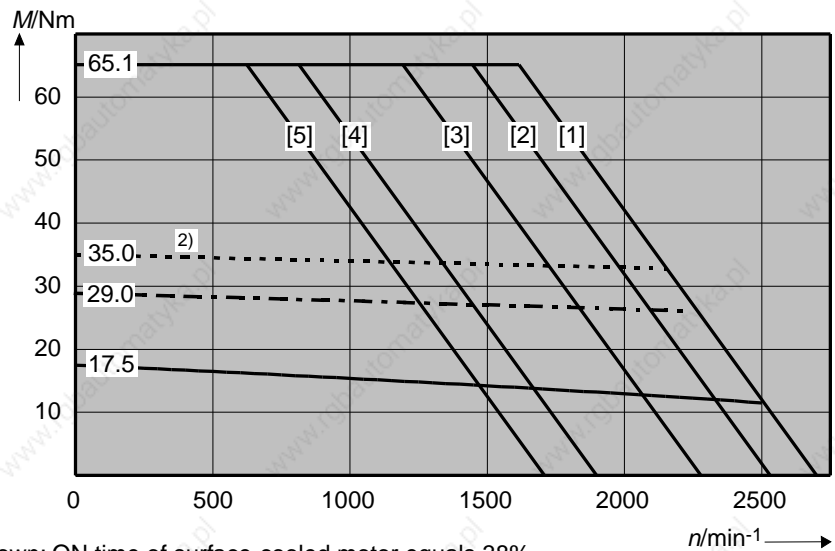

- 1) Shown: ON time of surface-cooled motor equals 38%.
- 2) Shown: ON time of surface-cooled motor equals 68%.

Fig 10.5: Torque-speed characteristics curve MDD 112

MDD 112 B-N at 3000 min⁻¹

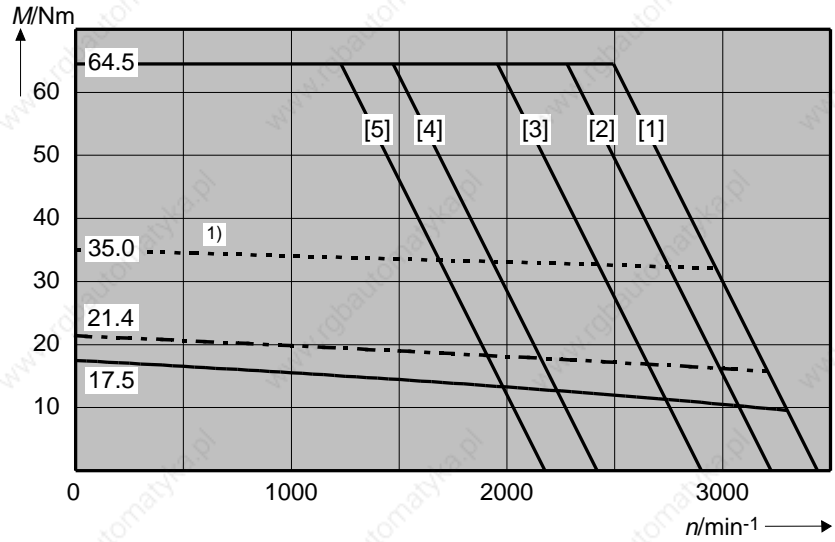

MDD 112 B-L at 3000 min⁻¹

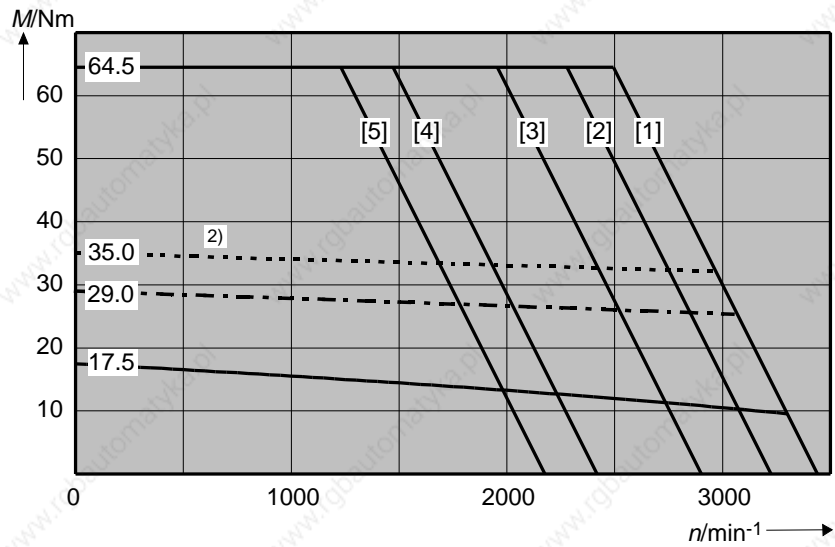

MDD 112 B-N at 4000 min⁻¹

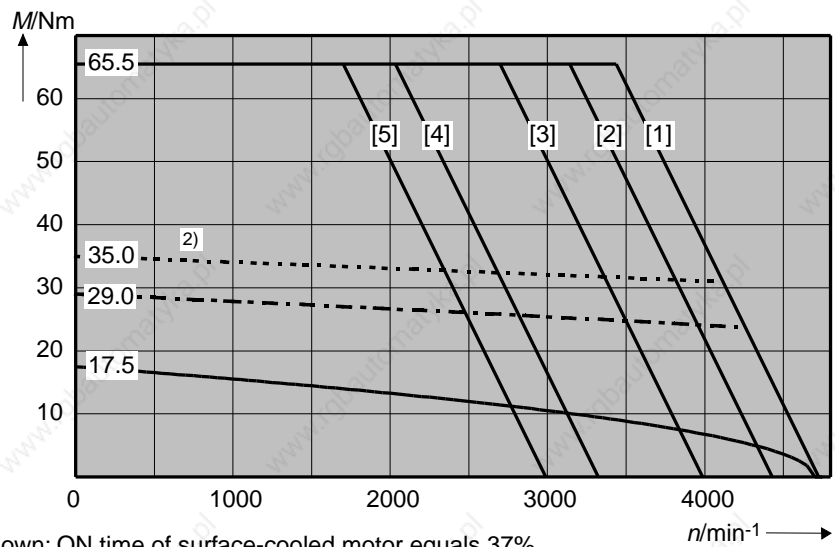

- 1) Shown: ON time of surface-cooled motor equals 37%.
- 2) Shown: ON time of surface-cooled motor equals 69%.

Fig 10.6: Torque-speed characteristics curve MDD 112

MDD 112 C-N at
1500 min⁻¹

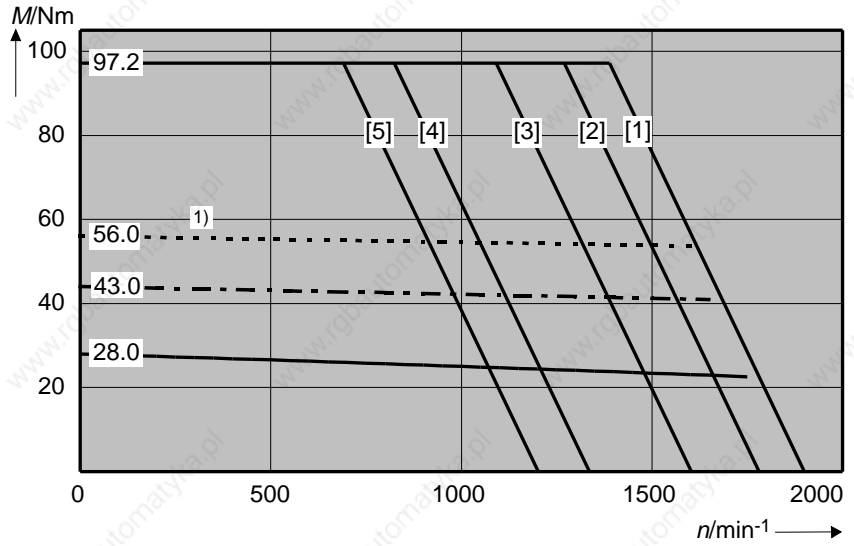

MDD 112 C-N at
2000 min⁻¹

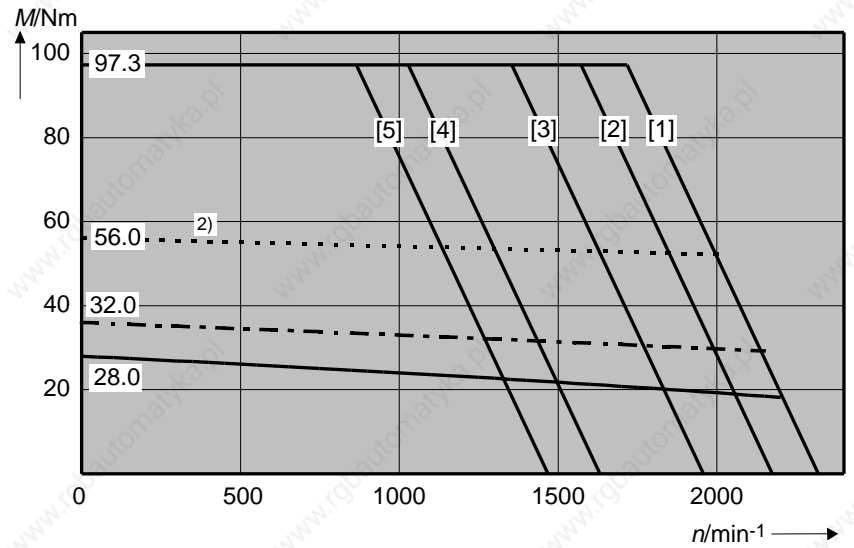

MDD 112 C-L at
2000 min⁻¹

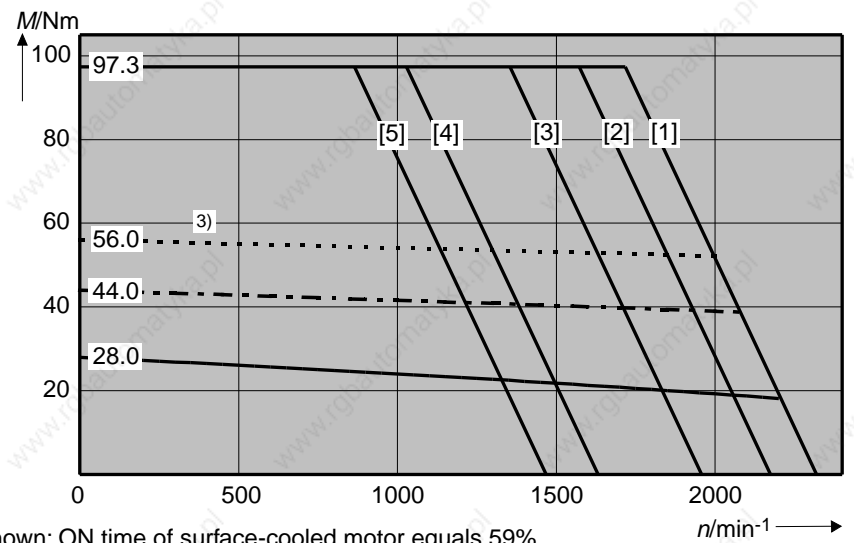

- 1) Shown: ON time of surface-cooled motor equals 59%.
- 2) Shown: ON time of surface-cooled motor equals 33%.
- 3) Shown: ON time of surface-cooled motor equals 62%.

Fig 10.7: Torque-speed characteristics curve MDD 112

MDD 112 C-N at
3000 min⁻¹

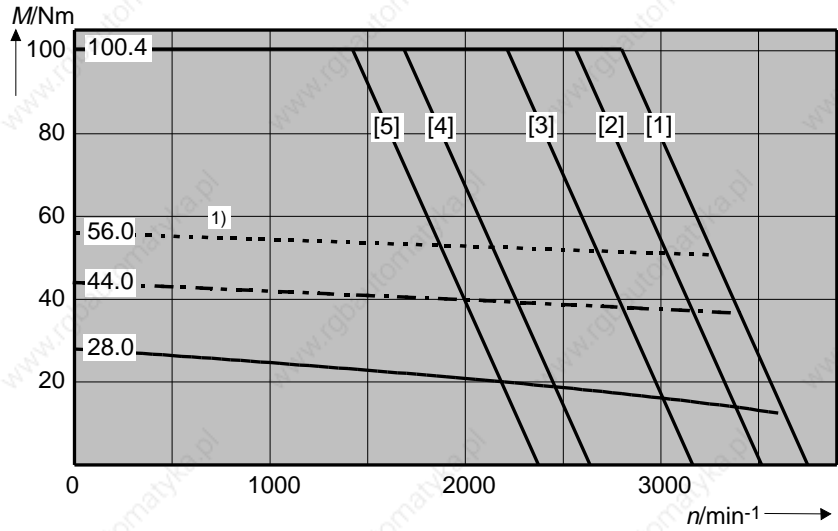

MDD 112 C-N at
4000 min⁻¹

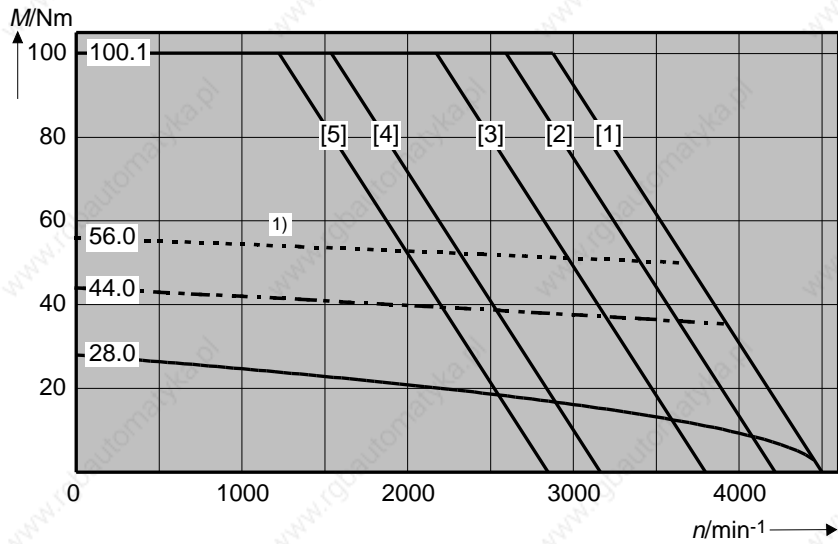

MDD 112 C-N at
6000 min⁻¹

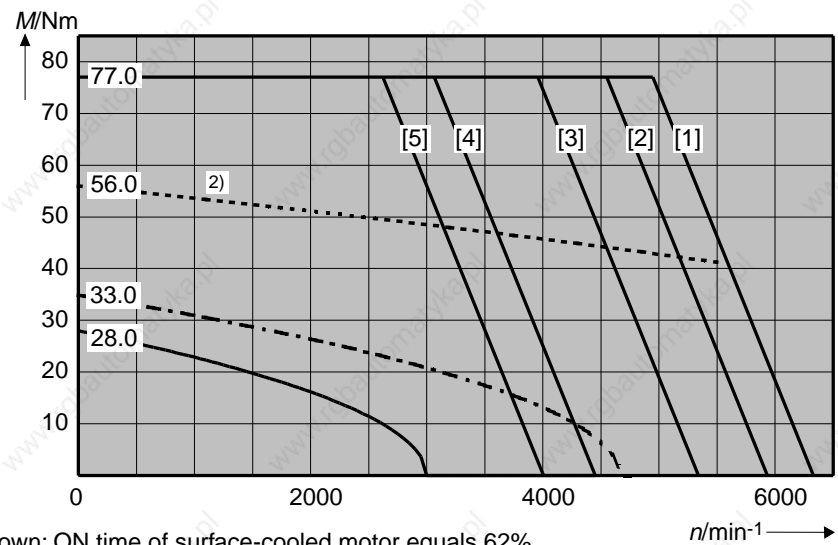

- 1) Shown: ON time of surface-cooled motor equals 62%.
- 2) Shown: ON time of surface-cooled motor equals 35%.

Fig 10.8: Torque-speed characteristics curve MDD 112

MDD 112 D-N at
1500 min⁻¹

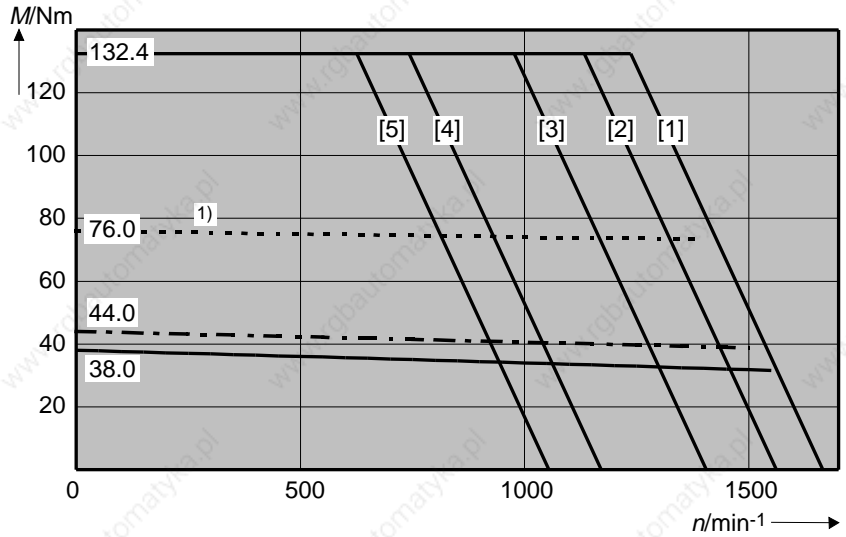

MDD 112 D-L at
1500 min⁻¹

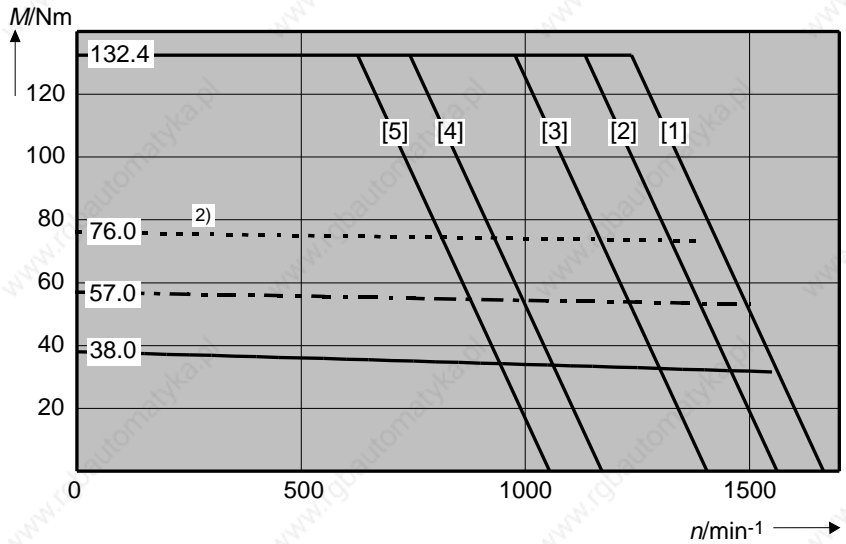

MDD 112 D-N at
2000 min⁻¹

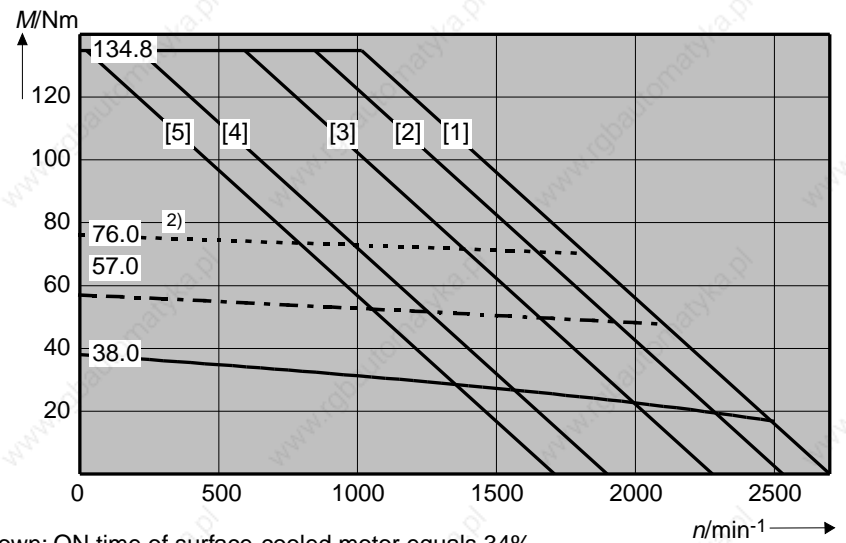

1) Shown: ON time of surface-cooled motor equals 34%.
2) Shown: ON time of surface-cooled motor equals 56%.

Fig 10.9: Torque-speed characteristics curve MDD 112

MDD 112 D-N at
3000 min⁻¹

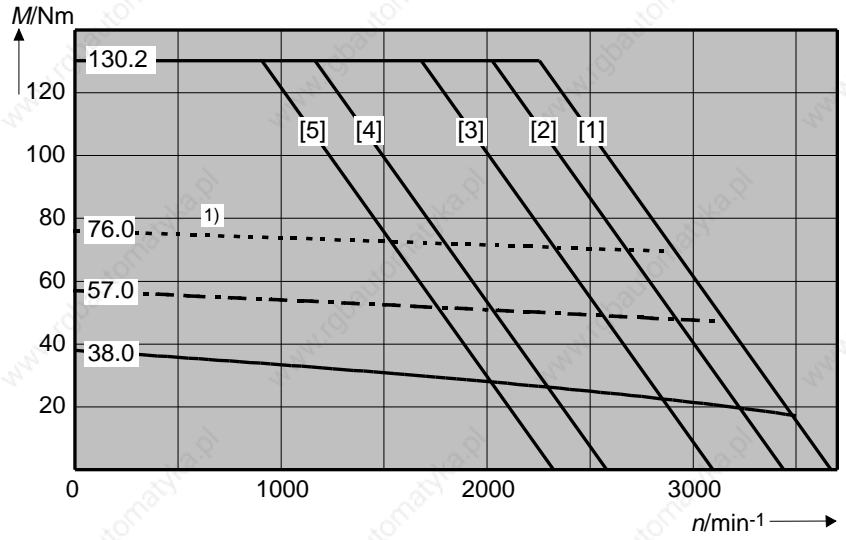

MDD 112 D-N at
4000 min⁻¹

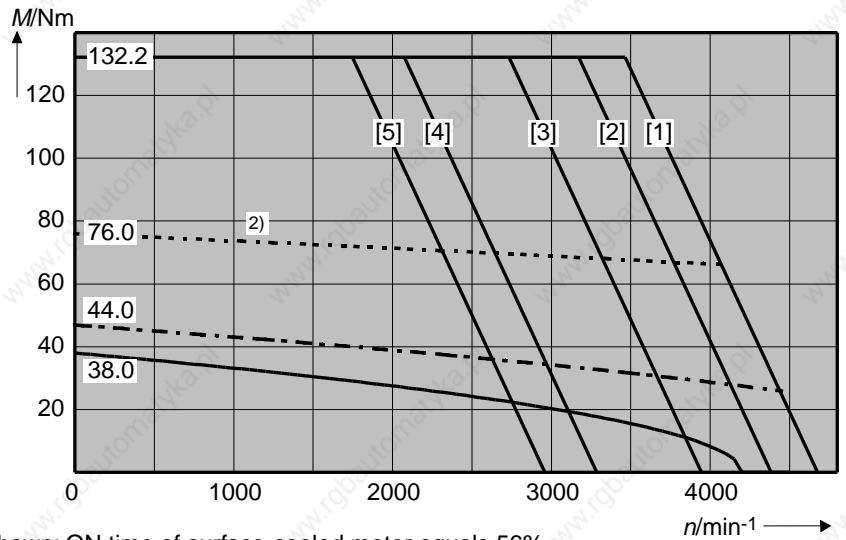

- 1) Shown: ON time of surface-cooled motor equals 56%.
- 2) Shown: ON time of surface-cooled motor equals 34%.

Fig 10.10: Torque-speed characteristics curve MDD 112

10.3. Shaft Load Capacity

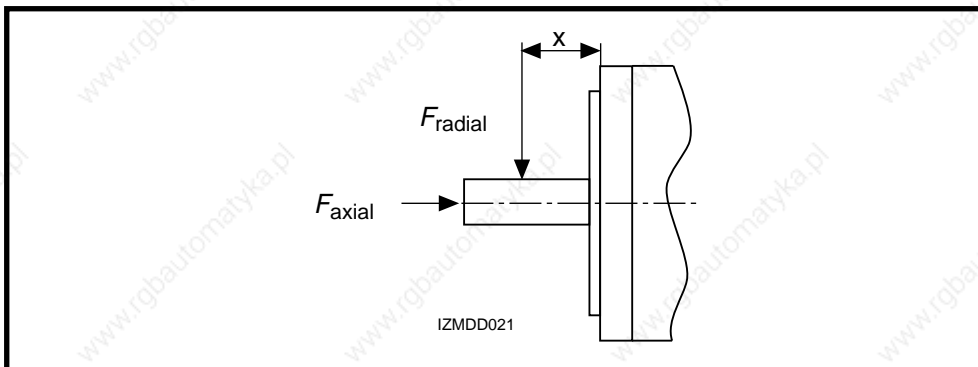

Fig 10.11: Shaft load

Permissible radial force

F_{radial}

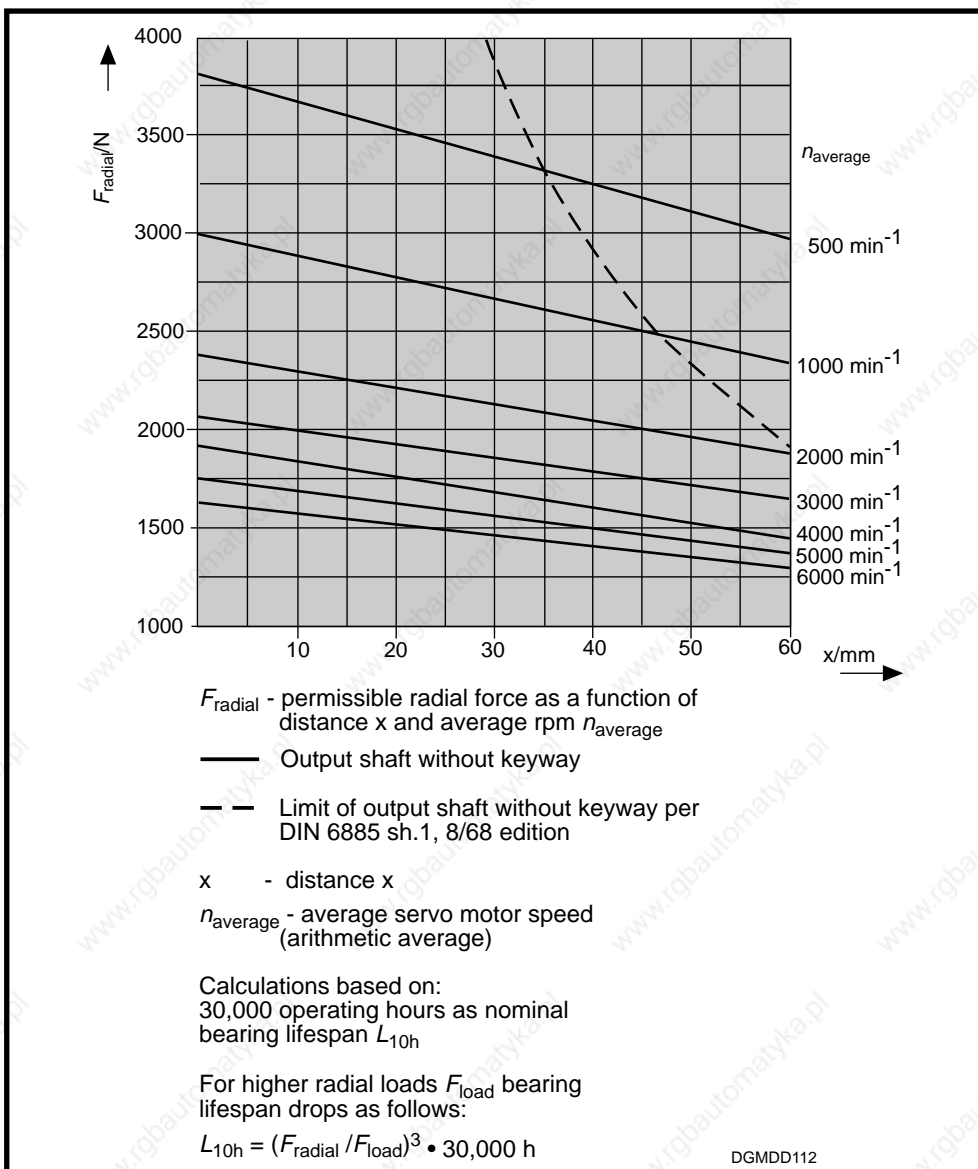

Fig 10.12: Permissible radial force

Permissible axial force

F_{axial}

$$F_{axial} = 0.35 \cdot F_{radial}$$

F_{axial} - permissible axial force

F_{radial} - permissible radial force

10.4. Dimensional Data

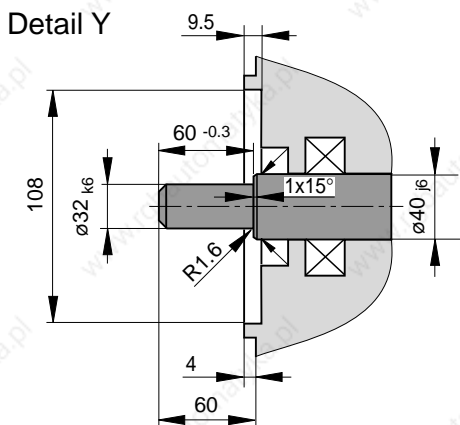
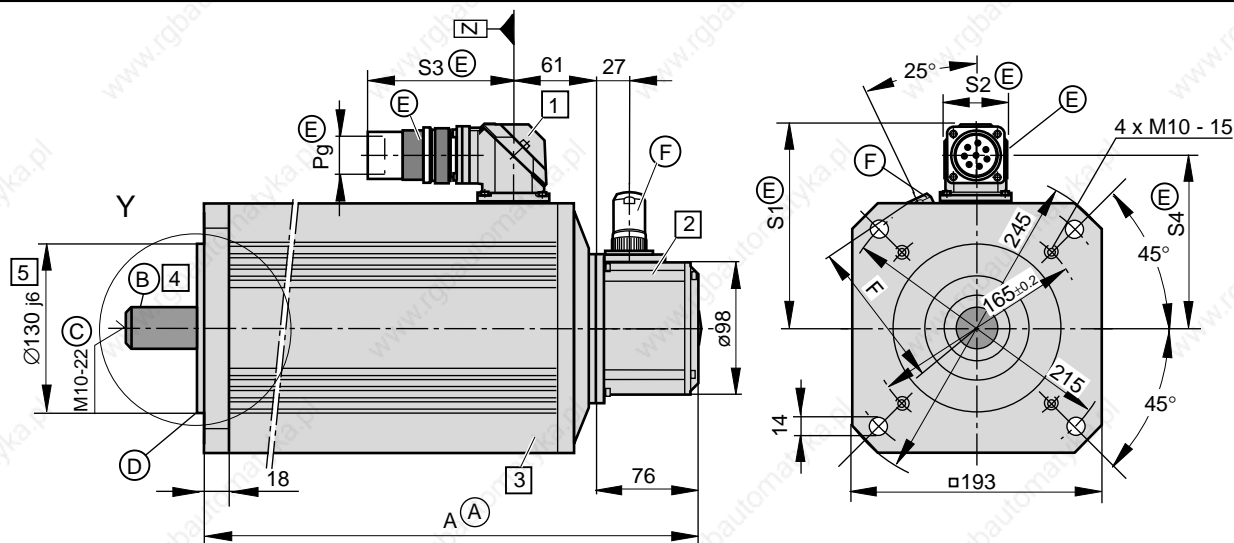

- Ⓒ Shaft end per DIN 748 section 3, 7/75 edition, IEC 72, 1971 edition, cylindrical
 - Center hole DS M3-8 per DIN 332 section 2, 5/83 edition
 - Max. tightening torque M_A for screws in the threads of the center hole: 10 Nm
- Ⓓ Flange type per DIN 42948, 11/65 edition, makes mounting possible
 - as per design B5 (throughholes in flange)
 - as per design B14 (threads in flange)
- Ⓔ **Motor power connector**
Depends on motor, must be ordered separately.

Ⓐ Dimensional table Dim. A

Size	Dim. A 1)
MDD 112 A	312
MDD 112 B	387
MDD 112 C	462
MDD 112 D	537

1) Bigger with some options. The then valid dimensions is indicated with the respective feature.

- Ⓑ Concentricity, excentricity and coaxiality to the shaft per DIN 42955, tolerance class R, 12/81 edition.

Table of dimensions

type	dim.	S1	S2	S3	S4	Pg
INS 108 3)		151	45	110	133	21
INS 172 2)		163	53	145	138	36

2) with MDD 112 B-N-040, MDD 112 C-N-030, MDD 112 C-N-040, MDD 112 C-N-060, MDD 112 D-N-020, MDD 112 D-N-030, MDD 112 D-N-040, MDD 112 B-L-030, MDD 112 C-L-020, MDD 112 D-L-015

3) other MDD 112

Ⓕ Feedback connector

Must be ordered separately.

Table of dimensions

Name	Connector type	Dim. F
straight conn.	INS 513	110
	INS 512	112
angle conn. 4)	INS 511	108
	INS 510	

4) Do not use with axially surface-cooled motor.

MBMDD112_1

Fig 10.13: Dimensional data MDD 112

Available Options

1 Power connection

The output direction of the electrical power connector is selected at the time the order is placed. Possible output direction is either:

- side A or
- side B
- to the right
- to the left

The drawing depicts side A as output direction. The dimensions of any other output direction are obtained by virtually turning the connector housing around the Z axis.

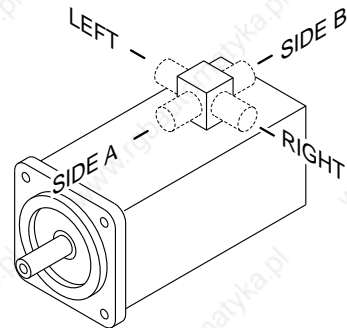

2 Motor feedback

- Digital servo feedback (DSF)
- Digital servo feedback (DSF) with integrated multiturn absolute encoder

The dimensions are identical.

3 Blocking brake

- without blocking brake
- with blocking brake: 14 Nm } The dimensions are identical.
- with blocking brake: 40 Nm (not available with MDD 112 A)
- with blocking brake: 60 Nm (not available with MDD 112)

Dimensional table for motor with holding brake of 40 Nm and 60 Nm

Size	Dim. A
MDD 112 B	437
MDD 112 C	512
MDD 112 D	587

4 Output shaft

- plain shaft (preferred type)
- with keyway per DIN 6885 sheet 1, 8/68 edition
(Note: balanced with entire key!)

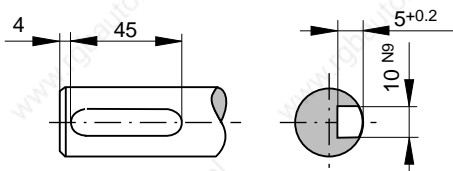

Matching key: DIN 6885-A 10 x 8 x 45

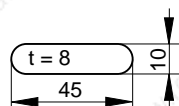

5 Special centering diameter

- $\varnothing 180_{j6}$

MBMDD112_2

Fig 10.14: Dimensional data MDD 112 - available options

10.5. Available Versions

Type code field:	Example:	MDD	112	B	N	015	N	2	L	130	G	B	0
1. Name Motor for digital drive controllers	MDD												
2. Motor size	112												
3. Motor lengths	A, B, C, D												
4. Housing design: Standard (suitable for natural convection and surface cooling) for surface-cooling with motors requiring a bigger power connector with respect to housing design N	N L ¹⁾												
5. Nominal speed 1500 min ⁻¹ 2000 min ⁻¹ 3000 min ⁻¹ 4000 min ⁻¹ 6000 min ⁻¹	015 020 030 040 060 ²⁾												
6. Balance class N per DIN VDE 0530 section 14, 2/93 edition R per DIN VDE 0530 section 14, 2/93 edition	N R												
7. Side B shaft end Standard (without side B shaft end)	2												
8. Motor feedback digital servo feedback digital servo feedback with integrated multiturn encoder	L M												
9. Centering diameter ø130 mm (standard) ø180 mm	130 180												
10. Output shaft plain shaft shaft with keyway per DIN 6885 sh. 1, 8/68 edition	G P												
11. Power connection connector to side A connector to side B connector to the right (looking onto motor shaft, connecting housing at top) connector to the left (looking onto motor shaft, connecting housing at top)	A B R L												
12. Blocking brake without blocking brake with 14.0 Nm blocking brake with 40.0 Nm blocking brake with 60.0 Nm blocking brake	0 1 2 ³⁾ 3 ³⁾												

¹⁾ Housing type "L" only with motor types MDD 112B-L-030, MDD 112C-L-020 and MDD 112D-L-015, as indicated in Technical Data section.
²⁾ with MDD 112C only
³⁾ not with MDD 112A

Quelle: INN 41.60 TLMD112

Fig 10.15: Type codes - MDD 112

Empty page

11. MDD 115

11.1. Technical Data

Designation	Symbol	Unit	Motor type MDD ...			
			115 A-N-015	115 B-N-015	115 C-N-015	115 D-N-015
Nominal motor speed ¹⁾	n	min ⁻¹	1500	1500	1500	1500
Continuous torque at standstill ²⁾	M_{dN}	Nm	28.0 (42.0) ⁵⁾	38.0 (48.1) ⁵⁾	47.0 (75.0) ⁵⁾	57.0 (88.0) ⁵⁾
Continuous current at standstill	I_{dN}	A	20.9 (31.3) ⁵⁾	27.1 (34.3) ⁵⁾	40.2 (64.1) ⁵⁾	38.5 (59.5) ⁵⁾
Theor. maximum torque ³⁾	M_{max}	Nm	87.1	118.2	146.1	177.3
Maximum current	I_{max}	A	93.9	121.9	180.7	173.4
Rotor moment of inertia ⁴⁾	J_M	kgm ²	123 x 10 ⁻⁴	172 x 10 ⁻⁴	222 x 10 ⁻⁴	271 x 10 ⁻⁴
Torque constant at 20 °C	K_m	Nm/A	1.34	1.40	1.17	1.48
Windings resistance at 20 °C	R_A	Ohm	0.54	0.39	0.21	0.25
Windings inductance	L_A	mH	8.3	9.2	3.5	4.2
Thermal time constant	T_{th}	min	90 (60) ⁵⁾	90 (60) ⁵⁾	90 (60) ⁵⁾	90 (60) ⁵⁾
Mass ⁴⁾	m_M	kg	33	41	52	60
			115 A-N-020	115 B-N-020	115 C-N-020	115 D-N-020
Nominal motor speed ¹⁾	n	min ⁻¹	2000	2000	2000	2000
Continuous torque at standstill ²⁾	M_{dN}	Nm	28.0 (34.5) ⁵⁾	38.0 (53.0) ⁵⁾	47.0 (75.0) ⁵⁾	57.0 (76.2) ⁵⁾
Continuous current at standstill	I_{dN}	A	27.8 (34.3) ⁵⁾	42.3 (59.0) ⁵⁾	51.5 (82.2) ⁵⁾	77.0 (102.9) ⁵⁾
Theor. maximum torque ³⁾	M_{max}	Nm	87.1	118.2	146.2	177.2
Maximum current	I_{max}	A	125.2	190.5	231.9	346.5
Rotor moment of inertia ⁴⁾	J_M	kgm ²	123 x 10 ⁻⁴	172 x 10 ⁻⁴	222 x 10 ⁻⁴	271 x 10 ⁻⁴
Torque constant at 20 °C	K_m	Nm/A	1.01	0.90	0.91	0.74
Windings resistance at 20 °C	R_A	Ohm	0.30	0.16	0.12	0.06
Windings inductance	L_A	mH	4.6	2.8	2.0	1.0
Thermal time constant	T_{th}	min	90 (60) ⁵⁾	90 (60) ⁵⁾	90 (60) ⁵⁾	90 (60) ⁵⁾
Mass ⁴⁾	m_M	kg	33	41	52	60
			115 A-N-030	115 B-N-030	115 C-N-030	
Nominal motor speed ¹⁾	n	min ⁻¹	3000	3000	3000	
Continuous torque at standstill ²⁾	M_{dN}	Nm	28.0 (41.6) ⁵⁾	38.0 (47.3) ⁵⁾	47.0 (62.8) ⁵⁾	
Continuous current at standstill	I_{dN}	A	42.4 (63.0) ⁵⁾	81.9 (102.9) ⁵⁾	77.0 (102.9) ⁵⁾	
Theor. maximum torque ³⁾	M_{max}	Nm	87.1	118.1	146.2	
Maximum current	I_{max}	A	190.9	368.4	346.4	
Rotor moment of inertia ⁴⁾	J_M	kgm ²	123 x 10 ⁻⁴	172 x 10 ⁻⁴	222 x 10 ⁻⁴	
Torque constant at 20 °C	K_m	Nm/A	0.66	0.46	0.61	
Windings resistance at 20 °C	R_A	Ohm	0.13	0.04	0.05	
Windings inductance	L_A	mH	2.0	1.2	0.9	
Thermal time constant	T_{th}	min	90 (60) ⁵⁾	90 (60) ⁵⁾	90 (60) ⁵⁾	
Mass ⁴⁾	m_M	kg	33	41	52	

Continued on next page

¹⁾ Usable motor speed is determined by the torque requirements of the application. The usable speed n_{max} found in the selection lists of the motor-drive combinations are binding for **standard applications**. The usable speed for other applications can be found using the required torque in the torque-speed characteristics curves

²⁾ With 60 K overtemperature at the motor housing.

³⁾ Achievable maximum torque is dependent upon the drive used. **Only** those maximum torques M_{max} found in the selection list of the motor-drive combinations are binding.

⁴⁾ Without blocking brake, without blower

⁵⁾ Parenthetical values apply to motors with surface cooling.

Designation	Symbol	Unit	Motor type MDD ...	
			115 A-L-020	115 B-L-015
Nominal motor speed ¹⁾	n	min ⁻¹	2000	1500
Continuous torque at standstill ²⁾	M_{dN}	Nm	28.0 (42.0) ⁵⁾	38.0 (53.0) ⁵⁾
Continuous current at standstill	I_{dN}	A	27.8 (41.7) ⁵⁾	27.1 (37.8) ⁵⁾
Theor. maximum torque ³⁾	M_{max}	Nm	87.1	118.2
Maximum current	I_{max}	A	125.2	121.9
Rotor moment of inertia ⁴⁾	J_M	kgm ²	123 x 10 ⁻⁴	172 x 10 ⁻⁴
Torque constant at 20 °C	K_m	Nm/A	1.01	1.40
Windings resistance at 20 °C	R_A	Ohm	0.30	0.39
Windings inductance	L_A	mH	4.6	9.2
Thermal time constant	T_{th}	min	90 (60) ⁵⁾	90 (60) ⁵⁾
Mass ⁴⁾	m_M	kg	33	41

1) Usable motor speed is determined by the torque requirements of the application. The usable speed n_{max} found in the selection lists of the motor-drive combinations are binding for **standard applications**. The usable speed for other applications can be found using the required torque in the torque-speed characteristics curves

2) With 60 K overtemperature at the motor housing.

3) Achievable maximum torque is dependent upon the drive used. **Only** those maximum torques M_{max} found in the selection list of the motor-drive combinations are binding.

4) Without blocking brake, without blower

5) Parenthetical values apply to motors with surface cooling.

Fig 11.1: Type dependent motor data

Designation	Symbol	Unit	Data
Permissible ambient temp.	T_{um}	°C	0 ... + 45
Permissible storage and transport temperature	T_L	°C	-20 ... + 80
Maximum installation elevation		m	1000 meters above sea level
Protection category			IP 65
Insulation classification			F
Housing coat			Black prime coat (RAL 9005)

Fig 11.2: General data - MDD 115

Designation	Symbol	Unit	Data Blocking Brake	
Principle of action			electrically- actuated release	
Holding torque	M_H	Nm	45	60
Nominal voltage	U_N	V	DC 24 ± 10%	DC 24 ± 10%
Nominal current	I_N	A	1.0	1.5
Moment of inertia	J_B	kgm ²	9.5 x 10 ⁻⁴	32 x 10 ⁻⁴
Release delay	t_L	ms	55	150
Clamping delay	t_K	ms	18	30
Mass	m_B	kg	1.9	3.5

Fig 11.3: Technical data - blocking brake

11.2. Torque-Speed Characteristics

MDD 115 A-N at
1500 min⁻¹

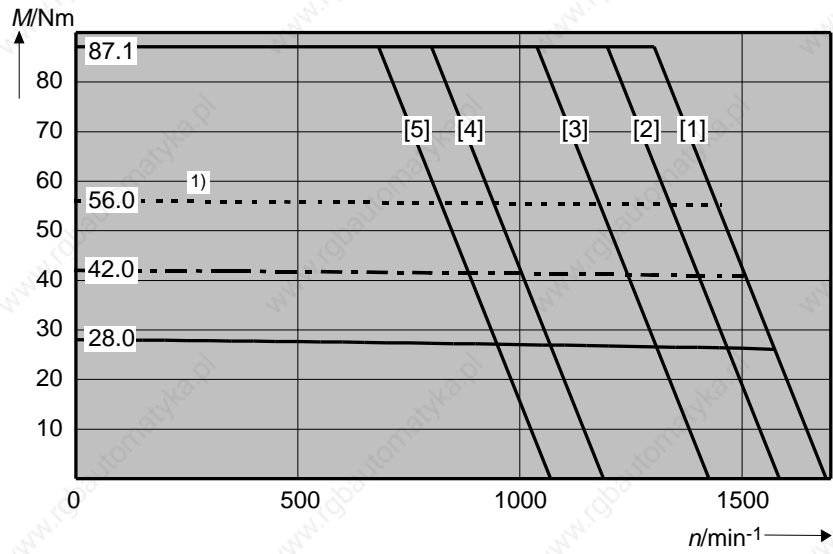

MDD 115 A-N at
2000 min⁻¹

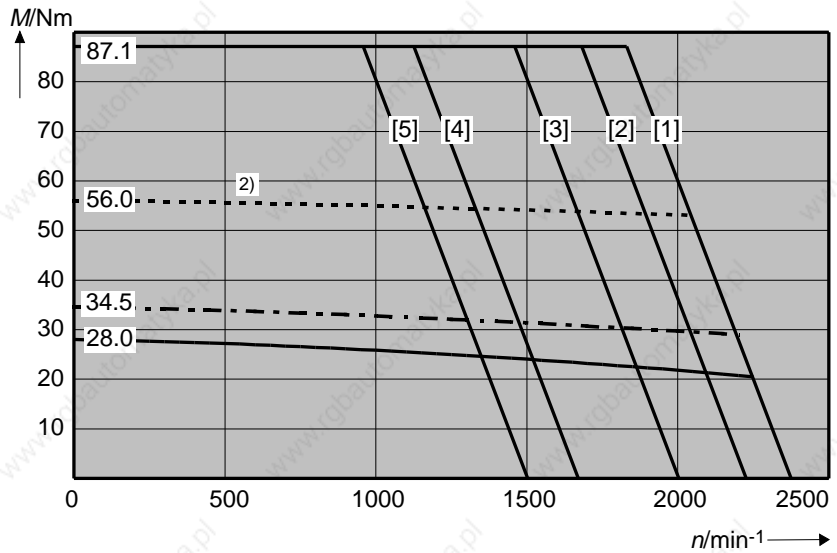

MDD 115 A-L at
2000 min⁻¹

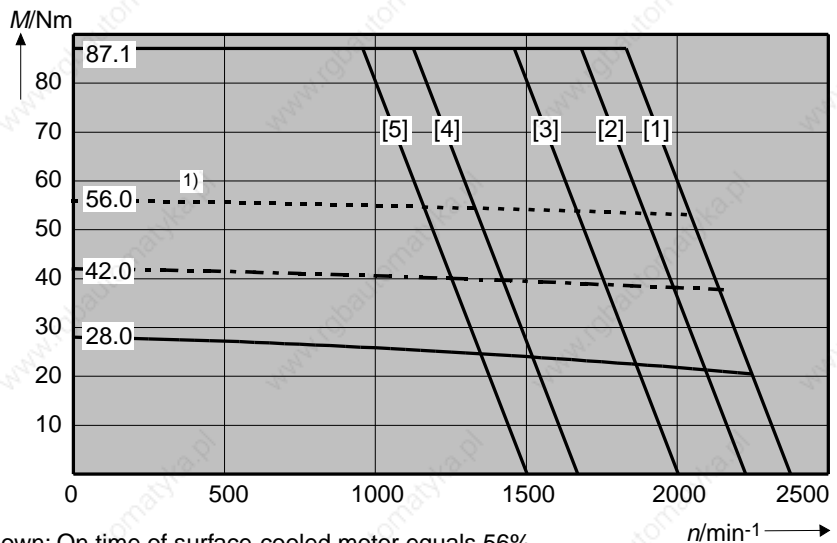

- 1) Shown: On time of surface-cooled motor equals 56%
- 2) Shown: On time of surface-cooled motor equals 38%

Fig 11.4: Torque-speed characteristics curve -MDD 115

MDD 115 A-N at
3000 min⁻¹

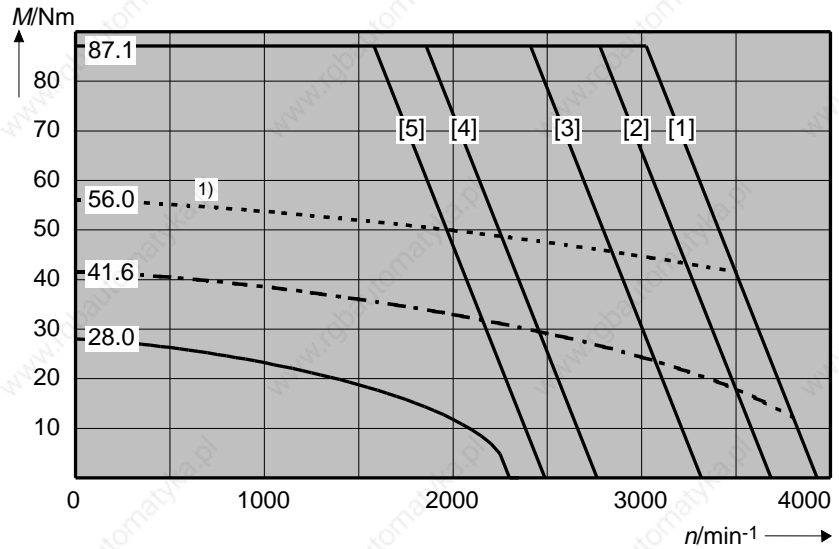

MDD 115 B-N at
1500 min⁻¹

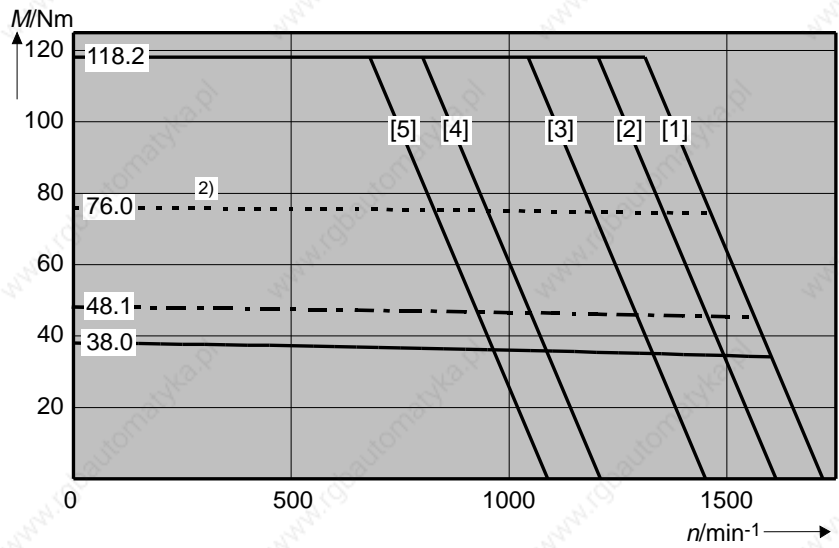

MDD 115 B-L at
1500 min⁻¹

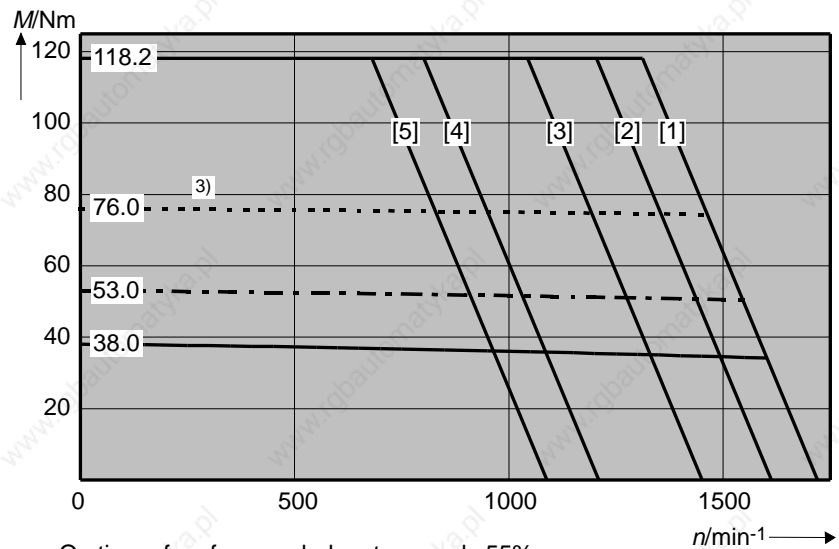

- 1) Shown: On time of surface-cooled motor equals 55%
- 2) Shown: On time of surface-cooled motor equals 40%
- 3) Shown: On time of surface-cooled motor equals 49%

Fig 11.5: Torque-speed characteristics curve - MDD 115

MDD 115 B-N at
2000 min⁻¹

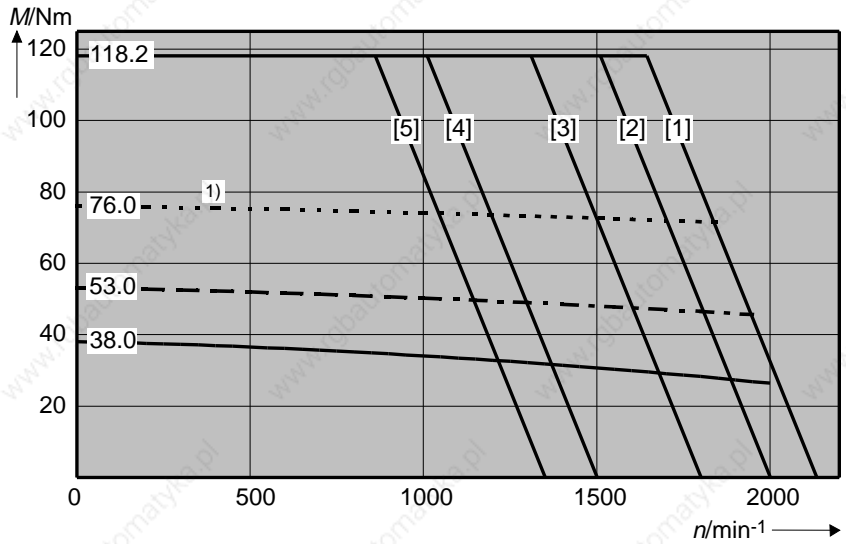

MDD 115 B-N at
3000 min⁻¹

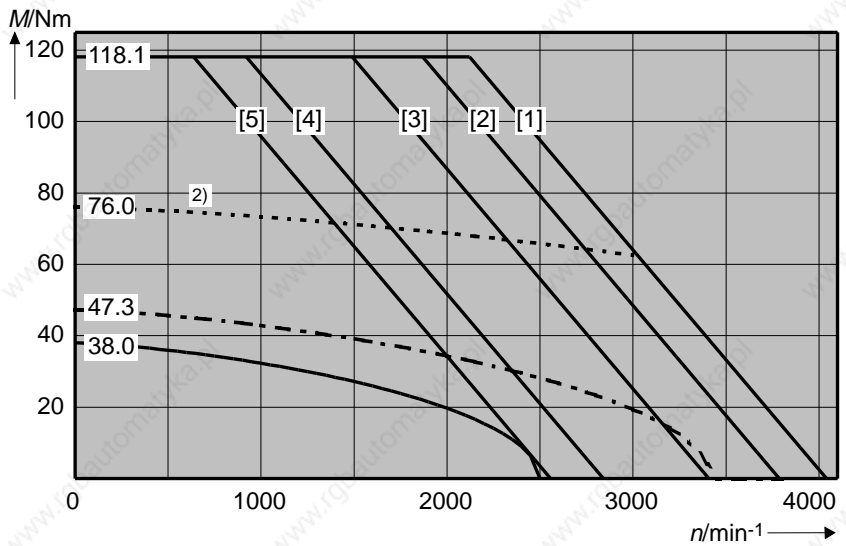

MDD 115 C-N at
1500 min⁻¹

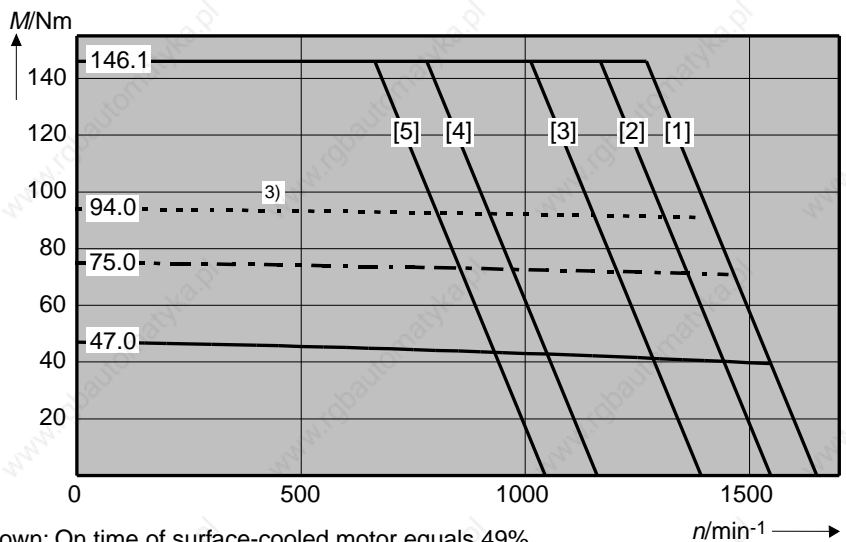

- 1) Shown: On time of surface-cooled motor equals 49%
- 2) Shown: On time of surface-cooled motor equals 39%
- 3) Shown: On time of surface-cooled motor equals 64%

Fig 11.6: Torque-speed characteristics curve - MDD 115

MDD 115 C-N at
2000 min⁻¹

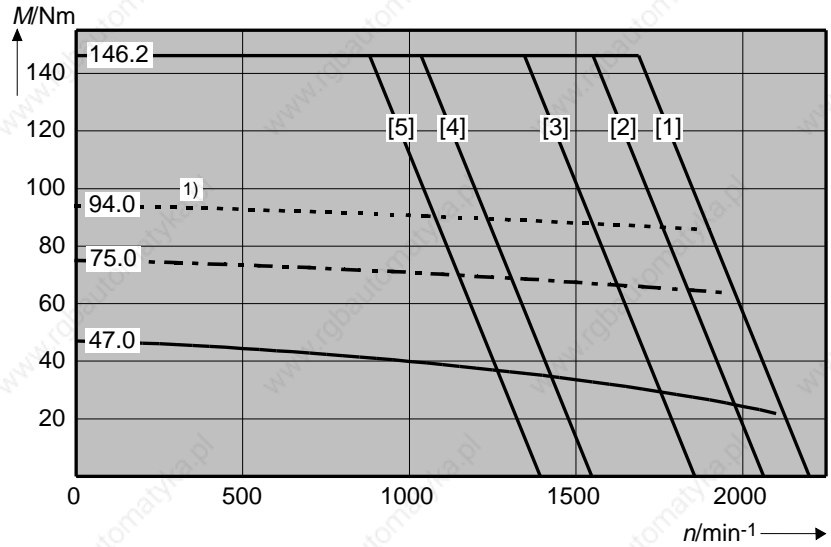

MDD 115 C-N at
3000 min⁻¹

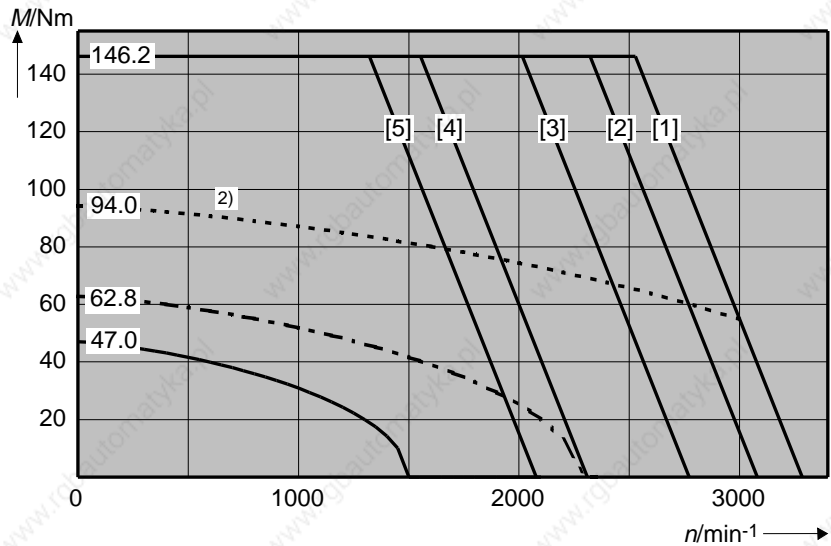

MDD 115 D-N at
1500 min⁻¹

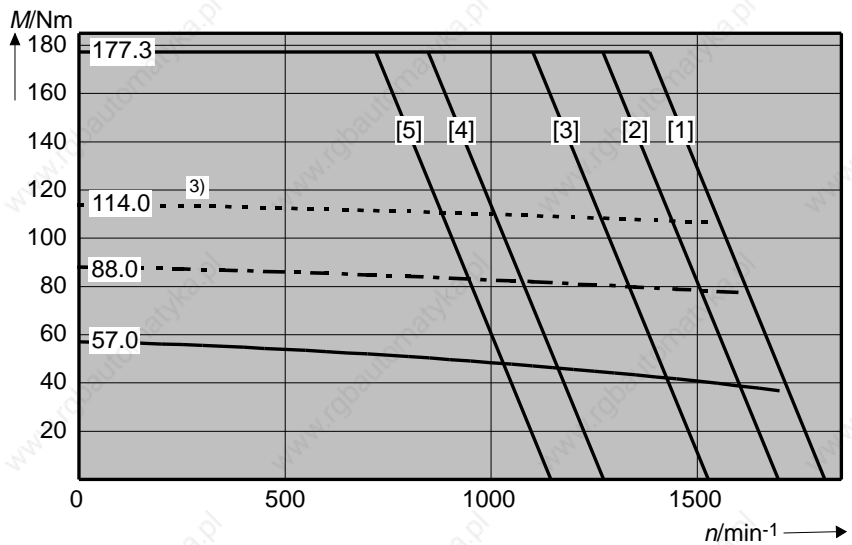

- 1) Shown: On time of surface-cooled motor equals 64%.
- 2) Shown: On time of surface-cooled motor equals 45%.
- 3) Shown: On time of surface-cooled motor equals 60%.

Fig 11.7: Torque-speed characteristics curve - MDD 115

MDD 115 D-N at
2000 min⁻¹

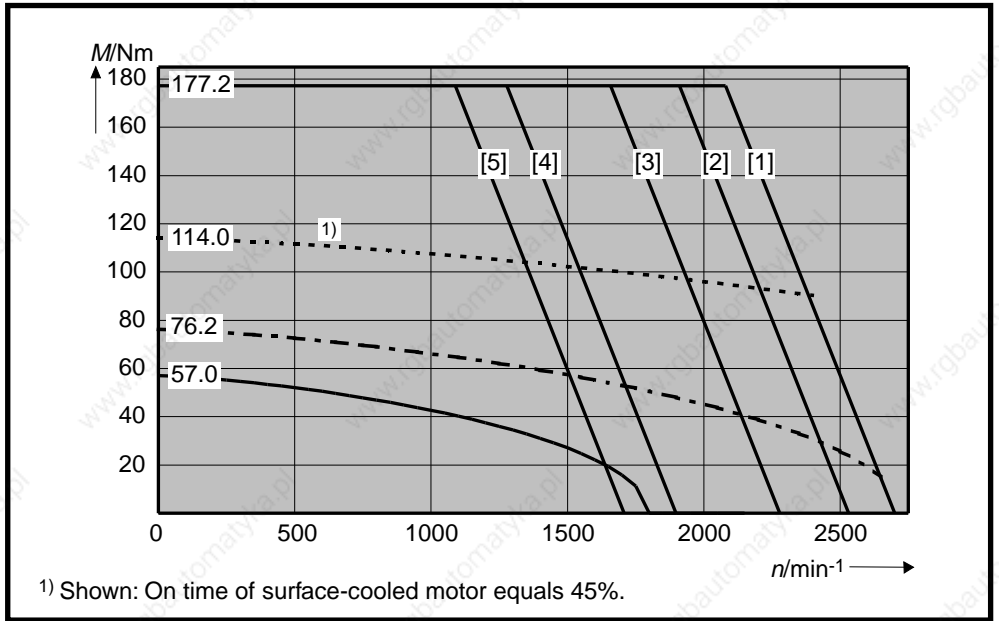

Fig 11.8: Torque-speed characteristics curve - MDD 115

11.3. Shaft Load Capacity

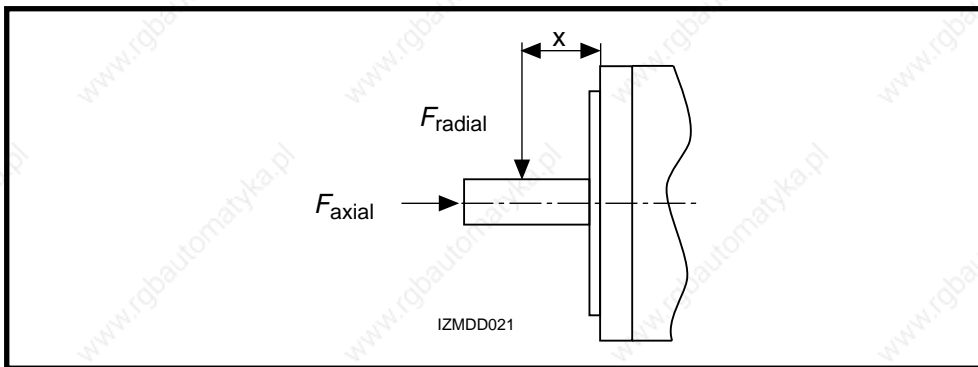

Fig 11.9: Shaft load

Permissible radial force

F_{radial}

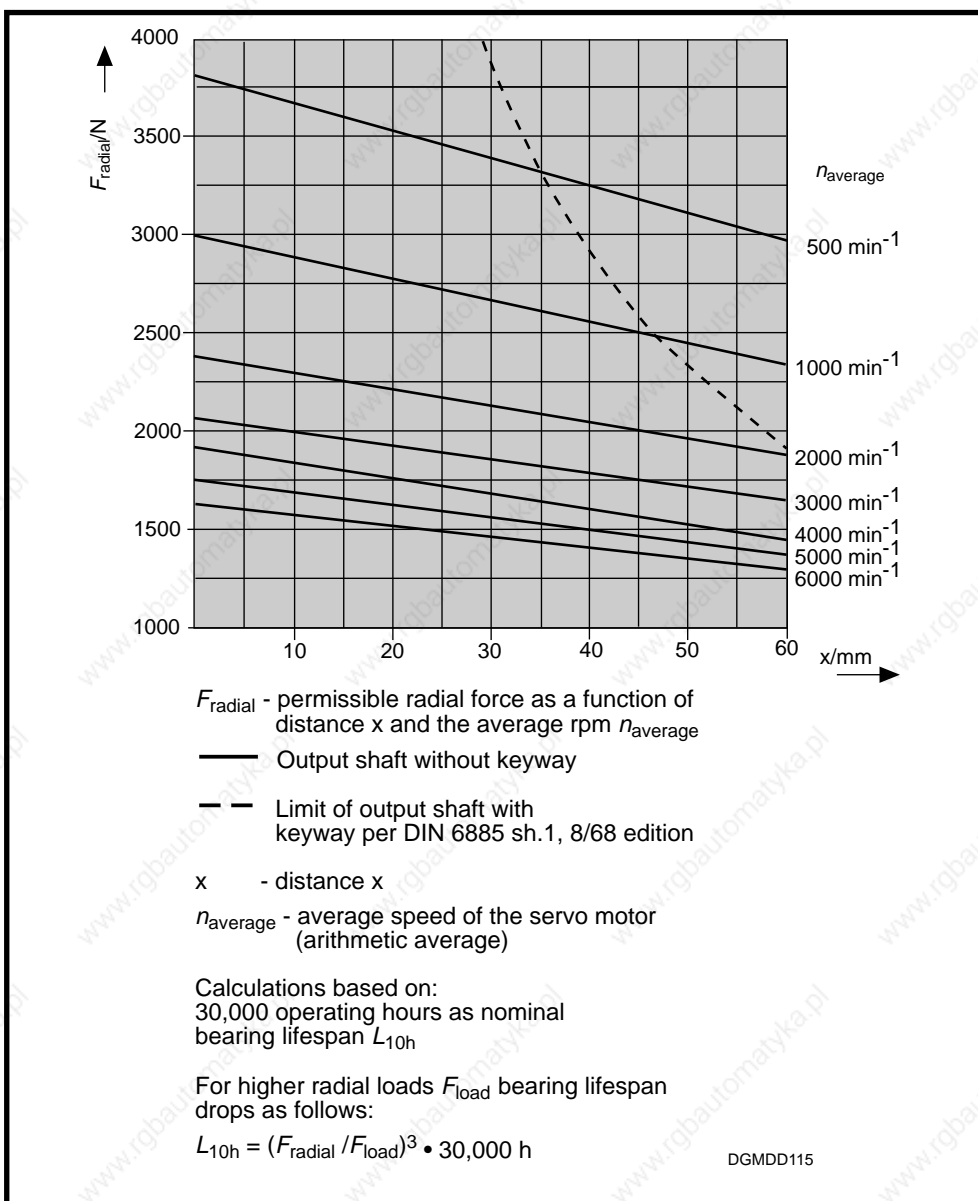

Fig 11.10: Permissible radial force

Permissible axial force

F_{axial}

$$F_{\text{axial}} = 0.35 \cdot F_{\text{radial}}$$

F_{axial} - permissible axial force

F_{radial} - permissible radial force

11.4. Dimensional Data

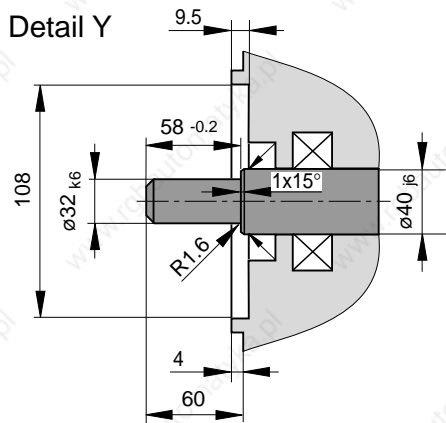
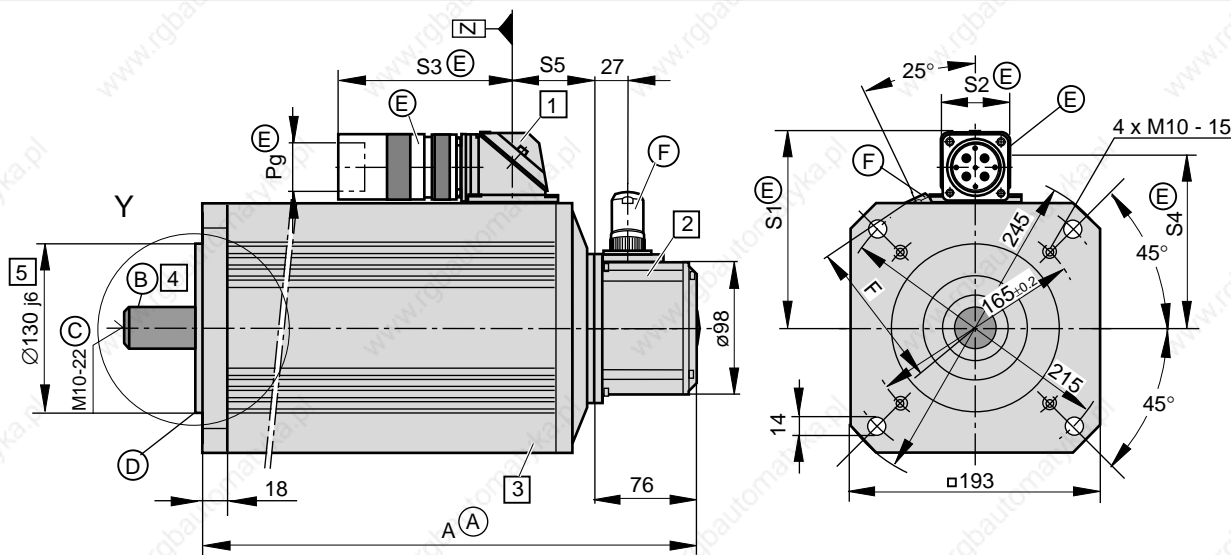

- Ⓒ Shaft end per DIN 748 section 3, 7/75 edition, IEC 72, 1971 edition, cylindrical
 - Center hole DS M3-8 per DIN 332 section 2, 5/83 edition
 - Max. tightening torque M_A for screws in the threads of the center hole: 10 Nm
- Ⓓ Flange type per DIN 42948, 11/65 edition, makes mounting possible
 - as per design B5 (throughholes in flange)
 - as per design B14 (threads in flange)

- Ⓔ **Motor power connector**
Depends on motor, must be ordered separately.

Table of dimensions

type \ dim.	S1	S2	S3	S4	S5 ¹⁾	Pg
INS 108 ²⁾	151	45	110	133	61	21
INS 172 ³⁾	163	53	145	138	73	36

²⁾ with MDD 115 A-N-015, MDD 115 A-N-020, MDD 115 B-N-015

³⁾ other MDD 115

Ⓐ **Dimensional table Dim. A**

Size	Dim. A ¹⁾
MDD 115 A	358
MDD 115 B	408
MDD 115 C	458
MDD 115 D	508

¹⁾ Bigger with some options.
The then valid dimensions is indicated with the respective feature.

Ⓑ Concentricity, excentricity and coaxiality to the shaft per DIN 42955, tolerance class R, 12/81 edition.

Ⓕ **Feedback connector**

Must be ordered separately.

Table of dimensions

Name	Connector type	Dim. F
straight conn.	INS 513	110
	INS 512	112
angle conn. ⁴⁾	INS 511	108
	INS 510	

⁴⁾ Do not use with axial, surface-cooled motor.

MBMDD115_1

Fig 11.11: Dimensional data - MDD 115

Available Options

1 Power connection

The output direction of the electrical power connector is selected at the time the order is placed. Possible output direction is either:

- side A or
- side B
- to the right
- to the left

The drawing depicts side A as output direction. The dimensions of any other output direction are obtained by virtually turning the connector housing around the Z axis.

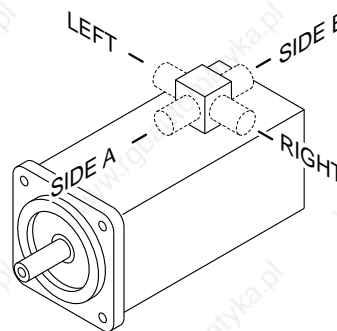

2 Motor feedback

- Digital servo feedback (DSF)
- Digital servo feedback (DSF) with integrated multiturn absolute encoder

The dimensions are identical.

3 Blocking brake

- without blocking brake
- with blocking brake: 45 Nm
- with blocking brake: 60 Nm

Dimensional table for motors with blocking brakes of 45 Nm and 60 Nm

S i z e	Dim. A	Dim. S5	
		INS 108	INS 172
MDD 115 A	418	104	116
MDD 115 B	468		
MDD 115 C	518		
MDD 115 D	568		

4 Output shaft

- plain shaft (preferred type)
- with keyway per DIN 6885 sheet 1, 8/68 edition
(Note: balanced with entire key!)

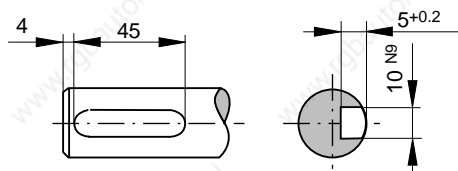

Matching key: DIN 6885-A 10 x 8 x 45

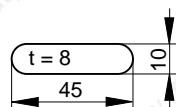

5 Special centering diameter

- $\varnothing 180_{j6}$

MBMDD115_2

Fig 11.12: Dimensional data MDD 115 - available options

11.5. Available Versions

Type code field:	Example:	MDD	115	B	N	015	N	2	L	130	G	B	0
1. Name Motor for digital drive controllers	MDD												
2. Motor size	115												
3. Motor lengths	A, B, C, D												
4. Housing design: Standard (suited for natural convection and surface cooling) for surface cooling in motors requiring a bigger power connector respective housing design N	N L ¹⁾												
5. Nominal speed 1500 min ⁻¹ 2000 min ⁻¹ 3000 min ⁻¹	015 020 030 ²⁾												
6. Balance class N per DIN VDE 0530 section 14, 2/93 edition R per DIN VDE 0530 section 14, 2/93 edition	N R												
7. Side B shaft end Standard (without side B shaft end)	2												
8. Motor feedback digital servo feedback digital servo feedback with integrated multiturn absolute encoder	L M												
9. Centering diameter ø130 mm (standard) ø180 mm	130 180												
10. Output shaft plain shaft shaft with keyway per DIN 6885 sh. 1, 8/68 edition	G P												
11. Power connection connector to side A connector to side B connector to the right (looking onto motor shaft, connecting housing at top) connector to the left (looking onto motor shaft, connecting housing at top)	A B R L												
12. Blocking brake without blocking brake with 45.0 Nm blocking brake with 60.0 Nm blocking brake	0 1 2												

1) Housing type "L" only possible with motors MDD 115A-L-020 and MDD 115B-L-015, as indicated in the Technical Data section.
2) Not with motor length "D"

Quelle: INN 41.60 TLMD115

Fig 11.13: Type codes - MDD 115

12. Electrical Power Connection

12.1. Terminal Diagram

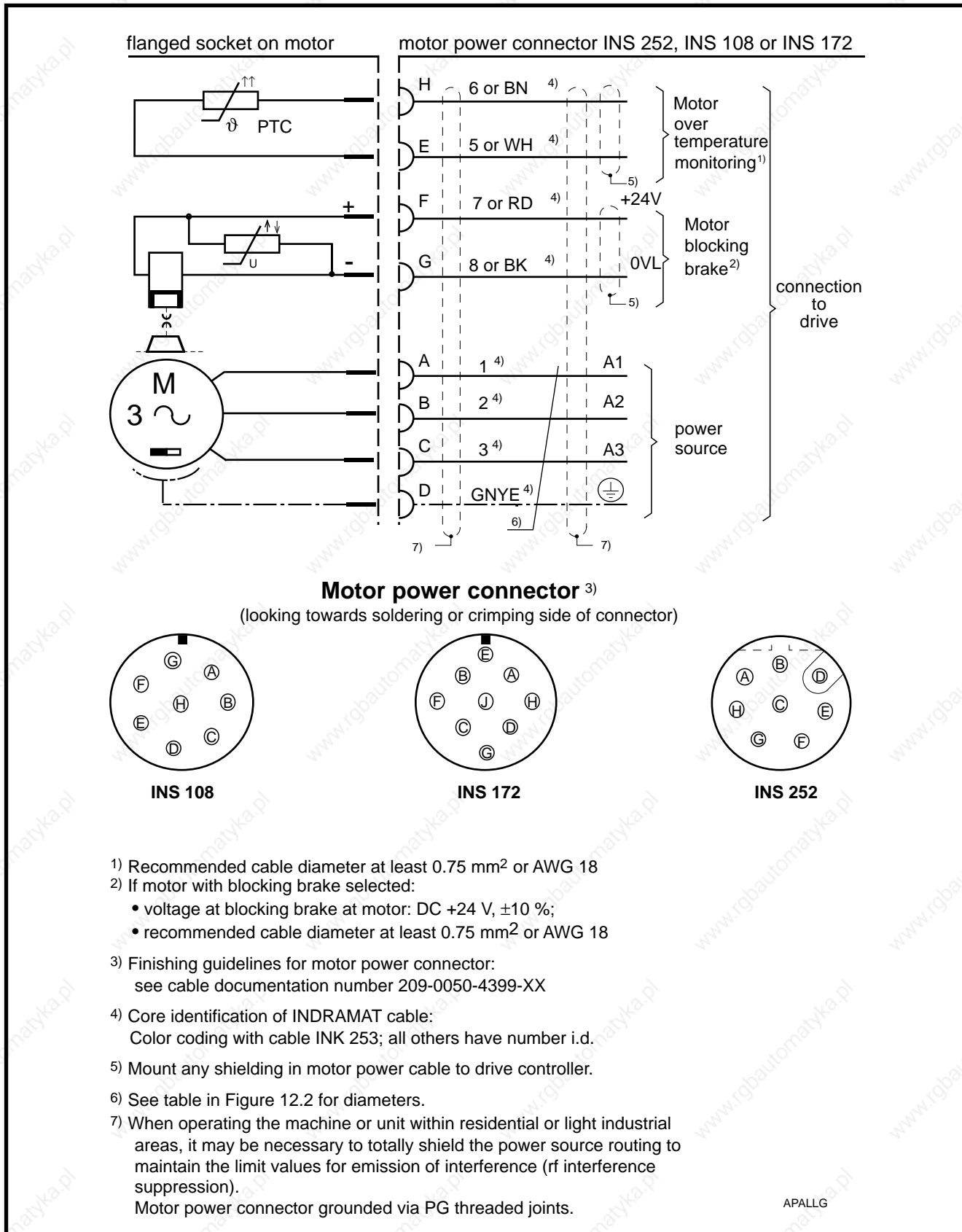

Fig 12.1: Power Connections

12.2. Connector to Cable Allocation

Servo motor MDD ...	Cooling	Motor phase current ¹⁾	Power connection minimum cross section ¹⁾		Motor power connector		INDRAMAT Motor power cable			
			mm ²	AWG ²⁾	Crimping type ³⁾	Soldering type ³⁾	without total shield		with total shield	Cross section mm ²
							standard	highly flex.		
021 A-N-100	natural convection	0.65	0.75	18	INS 252	INS 252	INK 253		INK 653	1.0
021 B-N-100		1.3	0.75	18	INS 252	INS 252	INK 253		INK 653	1.0
025 A-N-100	natural convection	1.2	0.75	18	INS 252	INS 252	INK 253		INK 653	1.0
025 B-N-100		2.2	0.75	18	INS 252	INS 252	INK 253		INK 653	1.0
025 C-N-100		3.2	0.75	18	INS 252	INS 252	INK 253		INK 653	1.0
041 A-N-100	natural convection	2.6	0.75	18	INS 252	INS 252	INK 253		INK 653	1.0
041 B-N-100		5.8	0.75	18	INS 252	INS 252	INK 253		INK 653	1.0
041 C-N-100		8.4	0.75	18	INS 252	INS 252	INK 253		INK 653	1.0
065 A-N-040	natural convection	1.5	0.75	18	INS 252	INS 252	INK 253		INK 653	1.0
065 A-N-060		2.1	0.75	18	INS 252	INS 252	INK 253		INK 653	1.0
065 B-N-040		2.9	0.75	18	INS 252	INS 252	INK 253		INK 653	1.0
065 B-N-060		4.8	0.75	18	INS 252	INS 252	INK 253		INK 653	1.0
065 C-N-040		4.5	0.75	18	INS 252	INS 252	INK 253		INK 653	1.0
065 C-N-060		6.4	0.75	18	INS 252	INS 252	INK 253		INK 653	1.0
065 D-N-040		5.2	0.75	18	INS 252	INS 252	INK 253		INK 653	1.0
065 D-N-060		8.4	0.75	16	INS 252	INS 252	INK 253		INK 653	1.0
065 B-N-040	surface cooling	3.2	0.75	18	INS 252	INS 252	INK 253		INK 653	1.0
065 B-N-060		5.5	0.75	18	INS 252	INS 252	INK 253		INK 653	1.0
065 C-N-040		5.8	0.75	18	INS 252	INS 252	INK 253		INK 653	1.0
065 C-N-060		8.3	0.75	16	INS 252	INS 252	INK 253		INK 653	1.0
065 D-N-040		6.6	0.75	18	INS 252	INS 252	INK 253		INK 653	1.0
065 D-N-060		10.9	1.0	14	INS 252	INS 252	INK 250		INK 650	1.5

Continued on next page

- 1) Motor phase currents and connection cross sections apply to S1 continuous and S6 intermittent operations with those limit values (respective ON time and duty cycle time), indicated in the torque-speed characteristics curves.
- 2) Minimum cross section of power connections as per EN 60 204, section 1, table 5, col. C or E or UL 508 table 50.2, but at least 0.75 mm² or AWG 18. Cables as per UL 508 can only be soldered not crimped to motor power connector.
- 3) The data following the slash define the type of bushing contact of the connector for either crimping or soldering.
- 4) For motor power connector as crimping type INS 108/04.
- 5) To be used only as soldering type with motor power connector.

Servo motor MDD ...	Cooling	Motor phase current ¹⁾	Power connection minimum cross section ¹⁾		Motor power connector		INDRAMAT Motor power cable			
			mm ²	AWG ²⁾	Crimping type ³⁾	Soldering type ³⁾	without total shield		with total shield	Cross section mm ²
							standard	highly flex.		
071 A-N-030	natural convection	3.0	0.75	18	INS 252	INS 252	INK 253	—	INK 653	1.0
071 A-N-040		4.1	0.75	18	INS 252	INS 252	INK 253	—	INK 653	1.0
071 A-N-060		6.1	0.75	18	INS 252	INS 252	INK 253	—	INK 653	1.0
071 B-N-030		6.0	0.75	18	INS 252	INS 252	INK 253	—	INK 653	1.0
071 B-N-040		8.9	0.75	16	—	INS 108/06	INK 253	—	INK 653	1.0
071 B-N-060		12.3	1.5	14	INS 108/02	INS 108/06	INK 250	—	INK 650	1.5
071 C-N-030		8.8	0.75	16	—	INS 108/06	INK 253	—	INK 653	1.0
071 C-N-040		11.9	1.5	14	INS 108/02	INS 108/06	INK 250	—	INK 650	1.5
071 C-N-060		18.0	2.5	12	INS 108/03	INS 108/06	INK 202	INK 402 ⁴⁾	INK 602	2.5
071 B-N-030		surface cooling	9.0	0.75	16	INS 252	INS 252	INK 253	—	INK 653
071 B-N-040	13.5		1.5	14	INS 108/02	INS 108/06	INK 250	—	INK 650	1.5
071 B-N-060	18.4		2.5	12	INS 108/03	INS 108/06	INK 202	INK 402 ⁴⁾	INK 602	2.5
071 C-N-030	13.2		1.5	14	INS 108/02	INS 108/06	INK 250	—	INK 650	1.5
071 C-N-040	18.0		2.5	12	INS 108/03	INS 108/06	INK 202	INK 402 ⁴⁾	INK 602	2.5
071 C-N-060	27.1		4.0	10	INS 108/04	INS 108/06	INK 203	INK 403 ⁵⁾	INK 603	4.0
090 A-N-020	natural convection		3.3	0.75	18	INS 252	INS 252	INK 253	—	INK 653
090 A-N-030		5.1	0.75	18	INS 252	INS 252	INK 253	—	INK 653	1.0
090 A-N-040		7.7	0.75	16	INS 252	INS 252	INK 253	—	INK 653	1.0
090 B-N-020		6.8	0.75	16	INS 252	INS 252	INK 253	—	INK 653	1.0
090 B-N-030		10.3	1.0	14	INS 108/02	INS 108/06	INK 250	—	INK 650	1.5
090 B-N-040		13.7	1.5	14	INS 108/02	INS 108/06	INK 250	—	INK 650	1.5
090 C-N-020		9.8	1.0	16	INS 108/02	INS 108/06	INK 250	—	INK 650	1.5
090 C-N-030		15.9	2.5	12	INS 108/03	INS 108/06	INK 202	INK 402 ⁴⁾	INK 602	2.5
090 C-N-040		19.9	2.5	12	INS 108/03	INS 108/06	INK 202	INK 402 ⁴⁾	INK 602	2.5
090 A-N-020	surface cooling	4.4	0.75	18	INS 252	INS 252	INK 253	—	INK 653	1.0
090 A-N-030		6.9	0.75	18	INS 252	INS 252	INK 253	—	INK 653	1.0
090 A-N-040		10.4	1.0	16	INS 252	INS 252	INK 250	—	INK 650	1.5
090 B-N-020		10.0	1.0	16	INS 252	INS 252	INK 250	—	INK 650	1.5
090 B-N-030		15.0	1.5	14	INS 108/02	INS 108/06	INK 250	—	INK 650	1.5
090 B-N-040		19.8	2.5	12	INS 108/03	INS 108/06	INK 202	INK 402 ⁴⁾	INK 602	2.5
090 C-N-020		15.2	1.5	12	INS 108/02	INS 108/06	INK 250	—	INK 650	1.5
090 C-N-030		24.5	4.0	10	INS 108/04	INS 108/06	INK 203	INK 403 ⁵⁾	INK 603	4.0
090 C-N-040		28.0	4.0	10	INS 108/04	INS 108/06	INK 203	INK 403 ⁵⁾	INK 603	4.0

Continued on next page

- 1) Motor phase currents and connection cross sections apply to S1 continuous and S6 intermittent operations with those limit values (respective ON time and duty cycle time), indicated in the torque-speed characteristics curves.
- 2) Minimum cross section of power connections as per EN 60 204, section 1, table 5, col. C or E or UL 508 table 50.2, but at least 0.75 mm² or AWG 18. Cables as per UL 508 can only be soldered not crimped to motor power connector.
- 3) The data following the slash define the type of bushing contact of the connector for either crimping or soldering.
- 4) For motor power connector as crimping type INS 108/04.
- 5) To be used only as soldering type with motor power connector.

Servo motor MDD ...	Cooling	Motor phase current ¹⁾	Power connection minimum cross section ¹⁾		Motor power connector		INDRAMAT Motor power cable				
			mm ²	AWG ²⁾	Crimping type ³⁾	Soldering type ³⁾	without total shield		with total shield	Cross section mm ²	
							standard	highly flex.			
093 A-N-020	natural convection	8.3	0.75	16	—	INS 108/06	INK 253	—	INK 653	1.0	
093 A-N-030		14.5	1.5	14	INS 108/02	INS 108/06	INK 250	—	INK 650	1.5	
093 A-N-040		19.0	2.5	10	INS 108/03	INS 108/06	INK 202	INK 402	INK 602	2.5	
093 A-N-060		30.1	6.0	8	INS 172/06	INS 172/25	INK 204	INK 404	INK 604	6.0	
093 B-N-020		13.8	1.5	14	INS 108/02	INS 108/06	INK 250	—	INK 650	1.5	
093 B-N-030		19.6	2.5	12	INS 108/03	INS 108/06	INK 202	INK 402 ⁴⁾	INK 602	2.5	
093 B-N-040		29.9	6.0	10	INS 172/06	INS 172/25	INK 204	INK 404	INK 604	6.0	
093 B-N-060		38.2	10.0	8	INS 172/10	INS 172/25	INK 205	INK 405	INK 605	10.0	
093 C-N-020		17.5	2.5	12	INS 108/03	INS 108/06	INK 202	INK 402 ⁴⁾	INK 602	2.5	
093 C-N-030		26.3	4.0	10	INS 108/04	INS 108/06	INK 203	INK 403 ⁵⁾	INK 603	4.0	
093 C-L-030		26.3	4.0	10	—	INS 172/25	INK 203	INK 403	INK 603	4.0	
093 C-N-040		37.0	10.0	8	INS 172/10	INS 172/25	INK 205	INK 405	INK 605	10.0	
093 C-N-060		53.2	16.0	6	INS 172/16	INS 172/25	INK 206	INK 406	INK 606	16.0	
093 D-N-015		20.2	2.5	10	INS 108/03	INS 108/06	INK 202	INK 402 ⁴⁾	INK 602	2.5	
093 D-N-020		25.5	4.0	10	INS 108/04	INS 108/06	INK 203	INK 403 ⁵⁾	INK 603	4.0	
093 D-N-030		33.8	6.0	8	INS 172/06	INS 172/25	INK 204	INK 404	INK 604	6.0	
093 D-N-040		51.6	16.0	6	INS 172/16	INS 172/25	INK 206	INK 406	INK 606	16.0	
093 A-N-020		surface cooling	10.9	1.0	14	INS 108/02	INS 108/06	INK 250	—	INK 650	1.5
093 A-N-030			18.9	2.5	12	INS 108/03	INS 108/06	INK 202	INK 402 ⁴⁾	INK 602	2.5
093 A-N-040			24.8	4.0	10	INS 108/04	INS 108/06	INK 203	INK 403 ⁵⁾	INK 603	4.0
093 A-N-060	39.2		10.0	8	INS 172/10	INS 172/25	INK 205	INK 405	INK 605	10.0	
093 B-N-020	19.0		2.5	10	INS 108/03	INS 108/06	INK 202	INK 402 ⁴⁾	INK 602	2.5	
093 B-N-030	27.1		4.0	10	INS 108/04	INS 108/06	INK 203	INK 403 ⁵⁾	INK 603	4.0	
093 B-N-040	41.2		10.0	8	INS 172/10	INS 172/25	INK 205	INK 405	INK 605	10.0	
093 B-N-060	52.7		16.0	6	INS 172/16	INS 172/25	INK 206	INK 406	INK 606	16.0	
093 C-N-020	25.1		4.0	10	INS 108/04	INS 108/06	INK 203	INK 403 ⁵⁾	INK 603	4.0	
093 C-N-030	28.0		4.0	10	INS 108/04	INS 108/06	INK 203	INK 403 ⁵⁾	INK 603	4.0	
093 C-L-030	37.7		10.0	6	INS 172/10	INS 172/25	INK 205	INK 405	INK 605	10.0	
093 C-N-040	53.1		16.0	4	INS 172/16	INS 172/25	INK 206	INK 406	INK 606	16.0	
093 C-N-060	76.4		25.0	3	—	INS 172/25	INK 207	INK 407	INK 607	25.0	
093 D-N-015	29.5		6.0	10	INS 172/06	INS 172/25	INK 204	INK 404	INK 604	6.0	
093 D-N-020	37.2		10.0	8	INS 172/10	INS 172/25	INK 205	INK 405	INK 605	10.0	
093 D-N-030	49.2		10.0	6	INS 172/10	INS 172/25	INK 205	INK 405	INK 605	10.0	
093 D-N-040	75.2		25.0	3	—	INS 172/25	INK 207	INK 407	INK 607	25.0	

Continued on next page

- 1) Motor phase currents and connection cross sections apply to S1 continuous and S6 intermittent operations with those limit values (respective ON time and duty cycle time), indicated in the torque-speed characteristics curves.
- 2) Minimum cross section of power connections as per EN 60 204, section 1, table 5, col. C or E or UL 508 table 50.2, but at least 0.75 mm² or AWG 18. Cables as per UL 508 can only be soldered not crimped to motor power connector.
- 3) The data following the slash define the type of bushing contact of the connector for either crimping or soldering.
- 4) For motor power connector as crimping type INS 108/04.
- 5) To be used only as soldering type with motor power connector.

Servo motor MDD ...	Cooling	Motor phase current ¹⁾	Power connection minimum cross section ¹⁾		Motor power connector		INDRAMAT Motor power cable			
			mm ²	AWG ²⁾	Crimping type ³⁾	Soldering type ³⁾	without total shield		with total shield	Cross section mm ²
							standard	highly flex.		
112 A-N-015	natural convection	6.8	0.75	18	—	INS 108/06	INK 253	—	INK 653	1.0
112 A-N-020		9.7	1.0	16	INS 108/02	INS 108/06	INK 250	—	INK 650	1.5
112 A-N-030		14.1	1.5	14	INS 108/02	INS 108/06	INK 250	—	INK 650	1.5
112 A-N-040		18.8	2.5	12	INS 108/03	INS 108/06	INK 202	INK 402 ⁴⁾	INK 602	2.5
112 B-N-015		11.4	1.0	14	INS 108/02	INS 108/06	INK 250	—	INK 650	1.5
112 B-N-020		16.9	2.5	12	INS 108/03	INS 108/06	INK 202	INK 402 ⁴⁾	INK 602	2.5
112 B-N-030		22.9	4.0	10	INS 108/04	INS 108/06	INK 203	INK 403 ⁵⁾	INK 603	4.0
112 B-L-030		22.9	4.0	10	—	INS 172/25	INK 203	INK 403	INK 603	4.0
112 B-N-040		33.9	6.0	8	INS 172/06	INS 172/25	INK 204	INK 404	INK 604	6.0
112 C-N-015		18.2	2.5	12	INS 108/03	INS 108/06	INK 202	INK 402 ⁴⁾	INK 602	2.5
112 C-N-020		24.3	4.0	10	INS 108/04	INS 108/06	INK 203	INK 403 ⁵⁾	INK 603	4.0
112 C-L-020		24.3	4.0	10	—	INS 172/25	INK 203	INK 403	INK 603	4.0
112 C-N-030		35.4	6.0	8	INS 172/06	INS 172/25	INK 204	INK 404	INK 604	6.0
112 C-N-040		47.5	10.0	6	INS 172/10	INS 172/25	INK 205	INK 405	INK 605	10.0
112 C-N-060		71.4	25.0	3	—	INS 172/25	INK 207	INK 407	INK 607	25.0
112 D-N-015		24.2	4.0	10	INS 108/04	INS 108/06	INK 203	INK 403 ⁵⁾	INK 603	4.0
112 D-L-015		24.2	4.0	10	—	INS 172/25	INK 203	INK 403	INK 603	4.0
112 D-N-020		35.8	6.0	8	INS 172/06	INS 172/25	INK 204	INK 404	INK 604	6.0
112 D-N-030		49.5	10.0	6	INS 172/10	INS 172/25	INK 205	INK 405	INK 605	10.0
112 D-N-040		72.1	25.0	3	—	INS 172/25	INK 207	INK 407	INK 607	25.0
112 A-N-015	surface cooling	8.4	0.75	16	—	INS 108/06	INK 253	—	INK 653	1.0
112 A-N-020		11.9	1.5	14	INS 108/02	INS 108/06	INK 250	—	INK 650	1.5
112 A-N-030		17.5	2.5	12	INS 108/03	INS 108/06	INK 202	INK 402 ⁴⁾	INK 602	2.5
112 A-N-040		23.2	4.0	10	INS 108/04	INS 108/06	INK 203	INK 403 ⁵⁾	INK 603	4.0
112 B-N-015		18.9	2.5	12	INS 108/03	INS 108/06	INK 202	INK 402 ⁴⁾	INK 602	2.5
112 B-N-020		28.0	4.0	10	INS 108/04	INS 108/06	INK 203	INK 403 ⁵⁾	INK 603	4.0
112 B-N-030		28.0	4.0	10	INS 108/04	INS 108/06	INK 203	INK 403 ⁵⁾	INK 603	4.0
112 B-L-030		37.9	10.0	8	INS 172/10	INS 172/25	INK 205	INK 405	INK 605	10.0
112 B-N-040		56.2	16.0	4	INS 172/16	INS 172/25	INK 206	INK 406	INK 606	16.0
112 C-N-015		28.0	4.0	10	INS 108/04	INS 108/06	INK 203	INK 403 ⁵⁾	INK 603	4.0
112 C-N-020		28.0	4.0	10	INS 108/04	INS 108/06	INK 203	INK 403 ⁵⁾	INK 603	4.0
112 C-L-020		38.2	10.0	8	INS 172/10	INS 172/25	INK 205	INK 405	INK 605	10.0
112 C-N-030		55.6	16.0	6	INS 172/16	INS 172/25	INK 206	INK 406	INK 606	16.0
112 C-N-040		74.5	25.0	3	INS 172/25	INS 172/25	INK 207	INK 407	INK 607	25.0
112 C-N-060		84.0	25.0	3	—	INS 172/25	INK 207	INK 407	INK 607	25.0
112 D-N-015		28.0	4.0	10	INS 108/04	INS 108/06	INK 203	INK 403 ⁵⁾	INK 603	4.0
112 D-L-015		36.3	10.0	8	INS 172/10	INS 172/25	INK 205	INK 405	INK 605	10.0
112 D-N-020		53.7	16.0	6	INS 172/16	INS 172/25	INK 206	INK 406	INK 606	16.0
112 D-N-030		74.2	25.0	3	—	INS 172/25	INK 207	INK 407	INK 607	25.0
112 D-N-040		84.0	25.0	3	—	INS 172/25	INK 207	INK 407	INK 607	25.0

Continued on next page



- 1) Motor phase currents and connection cross sections apply to S1 continuous and S6 intermittent operations with those limit values (respective ON time and duty cycle time), indicated in the torque-speed characteristics curves.
- 2) Minimum cross section of power connections as per EN 60 204, section 1, table 5, col. C or E or UL 508 table 50.2, but at least 0.75 mm² or AWG 18. Cables as per UL 508 can only be soldered not crimped to motor power connector.
- 3) The data following the slash define the type of bushing contact of the connector for either crimping or soldering.
- 4) For motor power connector as crimping type INS 108/04.
- 5) To be used only as soldering type with motor power connector.

Servo motor MDD ...	Cooling	Motor phase current ¹⁾	Power connection minimum cross section ¹⁾		Motor power connector		INDRAMAT Motor power cable				
			mm ²	AWG ²⁾	Crimping type ³⁾	Soldering type ³⁾	without total shield		with total shield	Cross section mm ²	
							standard	highly flex.			
115 A-N-015	natural convection	17.0	2.5	12	INS 108/03	INS 108/06	INK 202	INK 402 ⁴⁾	INK 602	2.5	
115 A-N-020		22.7	4.0	10	INS 108/04	INS 108/06	INK 203	INK 403 ⁵⁾	INK 603	4.0	
115 A-L-020		22.7	4.0	10	—	INS 172/25	INK 203	INK 403	INK 603	4.0	
115 A-N-030		34.6	6.0	8	INS 172/06	INS 172/25	INK 204	INK 404	INK 604	6.0	
115 B-N-015		22.1	4.0	10	INS 108/04	INS 108/06	INK 203	INK 403 ⁵⁾	INK 603	4.0	
115 B-L-015		22.1	4.0	10	—	INS 172/25	INK 203	INK 403	INK 603	4.0	
115 B-N-020		34.6	6.0	8	INS 172/06	INS 172/25	INK 204	INK 404	INK 604	6.0	
115 B-N-030		66.8	25.0	4	—	INS 172/25	INK 207	INK 407	INK 607	25.0	
115 C-N-015		32.8	6.0	8	INS 172/06	INS 172/25	INK 204	INK 404	INK 604	6.0	
115 C-N-020		42.1	10.0	6	INS 172/10	INS 172/25	INK 205	INK 405	INK 605	10.0	
115 C-N-030		62.9	16.0	4	INS 172/16	INS 172/25	INK 206	INK 406	INK 606	16.0	
115 D-N-015		31.5	6.0	8	INS 172/06	INS 172/25	INK 204	INK 404	INK 604	6.0	
115 D-N-020		62.9	16.0	4	INS 172/16	INS 172/25	INK 206	INK 406	INK 606	16.0	
115 A-N-015		surface cooling	25.6	4.0	10	INS 108/04	INS 108/06	INK 203	INK 403 ⁵⁾	INK 603	4.0
115 A-N-020			28.0	4.0	10	INS 108/04	INS 108/06	INK 203	INK 403 ⁵⁾	INK 603	4.0
115 A-L-020			34.0	6.0	8	INS 172/06	INS 172/25	INK 204	INK 404	INK 604	6.0
115 A-N-030			51.4	16.0	6	INS 172/16	INS 172/25	INK 206	INK 406	INK 606	16.0
115 B-N-015			28.0	4.0	10	INS 108/04	INS 108/06	INK 203	INK 403 ⁵⁾	INK 603	4.0
115 B-L-015	30.9		6.0	8	INS 172/06	INS 172/25	INK 204	INK 404	INK 604	6.0	
115 B-N-020	48.2		10.0	6	INS 172/10	INS 172/25	INK 205	INK 405	INK 605	10.0	
115 B-N-030	84.0		25.0	3	—	INS 172/25	INK 207	INK 407	INK 607	25.0	
115 C-N-015	52.3		16.0	6	INS 172/16	INS 172/25	INK 206	INK 406	INK 606	16.0	
115 C-N-020	67.1		25.0	4	—	INS 172/25	INK 207	INK 407	INK 607	25.0	
115 C-N-030	84.0		25.0	3	—	INS 172/25	INK 207	INK 407	INK 607	25.0	
115 D-N-015	48.6		10.0	6	INS 172/10	INS 172/25	INK 205	INK 405	INK 605	10.0	
115 D-N-020	84.0		25.0	3	—	INS 172/25	INK 207	INK 407	INK 607	25.0	

1) Motor phase currents and connection cross sections apply to S1 continuous and S6 intermittent operations with those limit values (respective ON time and duty cycle time), indicated in the torque-speed characteristics curves.
2) Minimum cross section of power connections as per EN 60 204, section 1, table 5, col. C or E or UL 508 table 50.2, but at least 0.75 mm² or AWG 18. Cables as per UL 508 can only be soldered not crimped to motor power connector.
3) The data following the slash define the type of bushing contact of the connector for either crimping or soldering.
4) For motor power connector as crimping type INS 108/04.
5) To be used only as soldering type with motor power connector.

Fig 12.2: Connector to cable allocations of the power connections

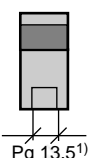
12.3. Power Connector (Motor Power Connector)

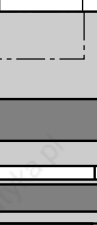
	Crimping connection					Soldering connection				
	Plug type	Max. connection cross section		Strain relief ¹⁾		Plug type	Max. connection cross section		Strain relief ¹⁾	
		Power core mm ²	Control core ²⁾ mm ²	Cable type INK	Part no.		Power core	Control core ²⁾ max.	Cable type INK	Part no.
 <p>INS 252 Pg 13,5¹⁾</p>	INS 252	1.0 - 1.5	0.75	253 250 653 650	257 379 257 379 257 379 257 379	INS 252	0.75 - 1.5 mm ² AWG 18-16	0.75 mm ² AWG 18	253 250 653 650	257 379 257 379 257 379 257 379
 <p>INS 108 Pg 21¹⁾</p>	INS 108/02	1.5	1.5	250 650	225 404 258 787 ⁴⁾	INS 108/06	0.75 - 6.0 mm ²	1.5 mm ²	253 250 202 203 204	260 097 225 404 219 857 218 767 218 767
	INS 108/03	2.5	1.5	202 602	219 857 227 526				402 403 404	227 526 219 857 218 767
	INS 108/04	4.0	1.5	203 402 603	218 767 227 526 218 767				653 650 602 603 604	258 787 ⁴⁾ 258 787 ⁴⁾ 227 526 218 767 218 767
 <p>INS 172 Pg 36¹⁾</p>	INS 172/06	6.0	1.5	204 404 604	220 874 ³⁾ 220 874 ³⁾ 220 874 ³⁾	INS 172/25	4.0 - 25.0 mm ²	1.5 mm ²	203 204 205 206 207	220 874 ³⁾ 220 874 ³⁾ 220 472 ³⁾ 220 472 ³⁾ 220 473
	INS 172/10	10.0	1.5	205 405 605	220 472 ³⁾ 221 554 ³⁾ 221 554 ³⁾				403 404 405 406 407	228 864 ³⁾ 220 874 ³⁾ 221 554 ³⁾ 220 472 ³⁾ 220 472 ³⁾
	INS 172/16	16.0	1.5	206 406 606	220 472 ³⁾ 220 472 ³⁾ 220 473				603 604 605 606 607	220 874 ³⁾ 220 874 ³⁾ 221 554 ³⁾ 220 473 220 473

¹⁾ Mount strain reliefs into the conduit threaded joint of the motor power connector to ensure interference-free operation. These must be ordered separately of the motor power connectors. Using the part no. indicated, the proper strain reliefs to correspond to the cable types can be ordered from INDRAMAT.
²⁾ For the motor blocking brake and motor temperature monitoring
³⁾ Part no. 220 474 needed for further reductions.
⁴⁾ Part no. 252 652 needed for further reductions.

Fig 12.3: Motor power connector

12.4. Motor Power Cable

12.4.1. Technical Data

Type	Power core cross section mm ²	Control core ¹⁾ cross section mm ²	Total shield	Power cable diameter mm	Minimum Bending Radius		Weight kg/m
					Fixed Routing mm	Flexible Routing mm	
INK 253	1.0	0.5	—	10.3 ± 0.3	65	105 ²⁾	0.11
INK 250	1.5	0.75	—	11.4 ± 0.4	90	140 ²⁾	0.19
INK 202	2.5	1.5	—	17.8 ± 0.5	120	200 ²⁾	0.47
INK 203	4.0	1.5	—	18.6 ± 0.5	120	270 ²⁾	0.57
INK 204	6.0	1.5	—	19.8 ± 0.5	120	300 ²⁾	0.67
INK 205	10.0	1.5	—	25.4 ± 0.7	200	380 ²⁾	1.10
INK 206	16.0	1.5	—	26.8 ± 0.7	220	390 ²⁾	1.33
INK 207	25.0	1.5	—	30.5 ± 0.7	240	430 ²⁾	1.70
INK 402	2.5	0.75	—	13.6 ± 0.5	85	140 ³⁾	0.27
INK 403	4.0	0.75 or 1.0	—	15.9 ± 0.6	100	160 ³⁾	0.37
INK 404	6.0	0.75 or 1.0	—	18.4 ± 0.6	105	175 ³⁾	0.50
INK 405	10.0	0.75 or 1.0	—	21.6 ± 0.8	130	220 ³⁾	0.74
INK 406	16.0	1.0	—	25.6 ± 0.6	150	250 ³⁾	1.10
INK 407	25.0	1.5	—	27.6 ± 0.7	180	270 ³⁾	1.52
INK 653	1.0	0.75	+	11.5 ± 0.3	75	100 ²⁾	0.25
INK 650	1.5	0.75	+	12.2 ± 0.4	80	120 ²⁾	0.39
INK 602	2.5	0.75	+	14.8 ± 0.5	85	140 ²⁾	0.59
INK 603	4.0	0.75 or 1.0	+	17.8 ± 0.6	110	180 ²⁾	0.60
INK 604	6.0	0.75 or 1.0	+	19.8 ± 0.6	120	200 ²⁾	0.81
INK 605	10.0	0.75 or 1.0	+	23.8 ± 0.6	150	240 ²⁾	1.10
INK 606	16.0	1.0	+	28.2 ± 0.6	160	280 ²⁾	1.40
INK 607	25.0	1.5	+	31.8 ± 0.8	180	300 ²⁾	1.73

¹⁾ For motor blocking brake and motor temperature monitoring
²⁾ Service life equals 1 000 000 bending loads.
³⁾ Service life equals 2 000 000 bending loads.

Fig 12.4: Type-dependent data of the motor power cable





12.4.2. General Data

Designation	Data
Transition cable to plug protection cat.	IP 65
Chemical Features	absolute resistance to mineral oils and greases hydrolysis resistant, silicon and halogen free
Permissible ambient temperatures for operation and storage	-30 to + 80 °C
Cable surface	Poor adhesion, prevents sticking in drag chains.
Cable length	maximum of 75 meters

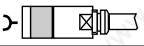
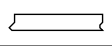
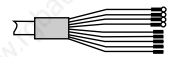
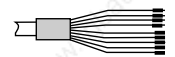
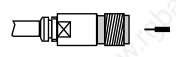
Fig 12.5: General data - motor power cable

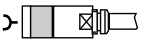

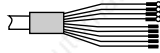
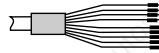
12.4.3. Ready-made motor power cable

Servo motor MDD ...	Cooling mode	Motor power connector	Motor power cable mm ²	Cable end for ...			
				Connection to drive using a terminal bolt (e.g.. DDS 2)	Intermediate clamp on terminal strip or connection to drive using terminal clamp (e.g.. DKS. DDS 3. DKC)	Intermediate connection using coupling 1)	
021 A-N-100	natural convection	 INS 252	 1.0	 IK• 001	 IK• 002	 IK• 005	
021 B-N-100		INS 252	1.0	IK• 001	IK• 002	IK• 005	
025 A-N-100	natural convection	INS 252	1.0	IK• 001	IK• 002	IK• 005	
025 B-N-100		INS 252	1.0	IK• 001	IK• 002	IK• 005	
025 C-N-100		INS 252	1.0	IK• 001	IK• 002	IK• 005	
041 A-N-100	natural convection	INS 252	1.0	IK• 001	IK• 002	IK• 005	
041 B-N-100		INS 252	1.0	IK• 001	IK• 002	IK• 005	
041 C-N-100		INS 252	1.0	IK• 001	IK• 002	IK• 005	
065 A-N-040	natural convection	INS 252	1.0	IK• 001	IK• 002	IK• 005	
065 A-N-060		INS 252	1.0	IK• 001	IK• 002	IK• 005	
065 B-N-040		INS 252	1.0	IK• 001	IK• 002	IK• 005	
065 B-N-060		INS 252	1.0	IK• 001	IK• 002	IK• 005	
065 C-N-040		INS 252	1.0	IK• 001	IK• 002	IK• 005	
065 C-N-060		INS 252	1.0	IK• 001	IK• 002	IK• 005	
065 D-N-040		INS 252	1.0	IK• 001	IK• 002	IK• 005	
065 D-N-060		INS 252	1.0	IK• 001	IK• 002	IK• 005	
065 B-N-040		surface cooling	INS 252	1.0	IK• 001	IK• 002	IK• 005
065 B-N-060			INS 252	1.0	IK• 001	IK• 002	IK• 005
065 C-N-040	INS 252		1.0	IK• 001	IK• 002	IK• 005	
065 C-N-060	INS 252		1.0	IK• 001	IK• 002	IK• 005	
065 D-N-040	INS 252		1.0	IK• 001	IK• 002	IK• 005	
065 D-N-060	INS 252		1.5	—	—	—	
Continued on next page							
1) For coupling connector mate: motor power connector							

Servo motor MDD ...	Cooling mode	Motor power connector	Motor power cable mm ²	Cable end for ...		
				Connection to drive using a terminal bolt (e.g.. DDS 2)	Intermediate clamp on terminal strip or connection to drive using terminal clamp (e.g.. DKS. DDS 3. DKC)	Intermediate connection using coupling 1)
						
071 A-N-030	natural convection	INS 252	1.0	IK• 001	IK• 002	IK• 005
071 A-N-040		INS 252	1.0	IK• 001	IK• 002	IK• 005
071 A-N-060		INS 252	1.0	IK• 001	IK• 002	IK• 005
071 B-N-030		INS 252	1.0	IK• 001	IK• 002	IK• 005
071 B-N-040		INS 108/06	1.0	IK• 011	IK• 012	IK• 003
071 B-N-060		INS 108/02	1.5	IK• 021	IK• 022	IK• 023
071 C-N-030		INS 108/06	1.0	IK• 011	IK• 012	IK• 003
071 C-N-040		INS 108/02	1.5	IK• 021	IK• 022	IK• 023
071 C-N-060		INS 108/03	2.5	IK• 041	IK• 042	IK• 043
071 B-N-030		surface cooling	INS 252	1.0	IK• 001	IK• 002
071 B-N-040	INS 108/02		1.5	IK• 021	IK• 022	IK• 023
071 B-N-060	INS 108/03		2.5	IK• 041	IK• 042	IK• 043
071 C-N-030	INS 108/02		1.5	IK• 021	IK• 022	IK• 023
071 C-N-040	INS 108/03		2.5	IK• 041	IK• 042	IK• 043
071 C-N-060	INS 108/04		4.0	IK• 061	IK• 062	IK• 063
090 A-N-020	natural convection		INS 252	1.0	IK• 001	IK• 002
090 A-N-030		INS 252	1.0	IK• 001	IK• 002	IK• 005
090 A-N-040		INS 252	1.0	IK• 001	IK• 002	IK• 005
090 B-N-020		INS 252	1.0	IK• 001	IK• 002	IK• 005
090 B-N-030		INS 108/02	1.5	IK• 021	IK• 022	IK• 023
090 B-N-040		INS 108/02	1.5	IK• 021	IK• 022	IK• 023
090 C-N-020		INS 108/02	1.5	IK• 021	IK• 022	IK• 023
090 C-N-030		INS 108/03	2.5	IK• 041	IK• 042	IK• 043
090 C-N-040		INS 108/03	2.5	IK• 041	IK• 042	IK• 043
090 A-N-020		surface cooling	INS 252	1.0	IK• 001	IK• 002
090 A-N-030	INS 252		1.0	IK• 001	IK• 002	IK• 005
090 A-N-040	INS 252		1.5	—	—	—
090 B-N-020	INS 252		1.5	—	—	—
090 B-N-030	INS 108/02		1.5	IK• 021	IK• 022	IK• 023
090 B-N-040	INS 108/03		2.5	IK• 041	IK• 042	IK• 043
090 C-N-020	INS 108/02		1.5	IK• 021	IK• 022	IK• 023
090 C-N-030	INS 108/04		4.0	IK• 061	IK• 062	IK• 063
090 C-N-040	INS 108/04		4.0	IK• 061	IK• 062	IK• 063

Continued on next page

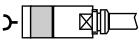
1) For coupling connector mate: motor power connector

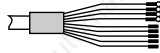
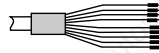
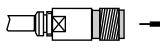
Servo motor MDD ...	Cooling mode	Motor power connector 	Motor power cable mm ² 	Cable end for ...			
				Connection to drive using a terminal bolt (e.g.. DDS 2) 	Intermediate clamp on terminal strip or connection to drive using terminal clamp (e.g.. DKS. DDS 3. DKC) 	Intermediate connection using coupling 1) 	
093 A-N-020	natural convection	INS 108/06	1.0	IK• 011	IK• 012	IK• 003	
093 A-N-030		INS 108/02	1.5	IK• 021	IK• 022	IK• 023	
093 A-N-040		INS 108/03	2.5	IK• 041	IK• 042	IK• 043	
093 A-N-060		INS 172/06	6.0	IK• 101	IK• 102	IK• 108	
093 B-N-020		INS 108/02	1.5	IK• 021	IK• 022	IK• 023	
093 B-N-030		INS 108/03	2.5	IK• 041	IK• 042	IK• 043	
093 B-N-040		INS 172/06	6.0	IK• 101	IK• 102	IK• 108	
093 B-N-060		INS 172/10	10.0	IK• 121	IK• 122	IK• 128	
093 C-N-020		INS 108/03	2.5	IK• 041	IK• 042	IK• 043	
093 C-N-030		INS 108/04	4.0	IK• 061	IK• 062	IK• 063	
093 C-L-030		INS 172/25	4.0	—	—	—	
093 C-N-040		INS 172/10	10.0	IK• 121	IK• 122	IK• 128	
093 C-N-060		INS 172/16	16.0	IK• 141	IK• 142	IK• 148	
093 D-N-015		INS 108/03	2.5	IK• 041	IK• 042	IK• 043	
093 D-N-020		INS 108/04	4.0	IK• 061	IK• 062	IK• 063	
093 D-N-030		INS 172/06	6.0	IK• 101	IK• 102	IK• 108	
093 D-N-040		INS 172/16	16.0	IK• 141	IK• 142	IK• 148	
093 A-N-020		surface cooling	INS 108/02	1.5	IK• 021	IK• 022	IK• 023
093 A-N-030			INS 108/03	2.5	IK• 041	IK• 042	IK• 043
093 A-N-040			INS 108/04	4.0	IK• 061	IK• 062	IK• 063
093 A-N-060	INS 172/10		10.0	IK• 121	IK• 122	IK• 128	
093 B-N-020	INS 108/03		2.5	IK• 041	IK• 042	IK• 043	
093 B-N-030	INS 108/04		4.0	IK• 061	IK• 062	IK• 063	
093 B-N-040	INS 172/10		10.0	IK• 121	IK• 122	IK• 128	
093 B-N-060	INS 172/16		16.0	IK• 141	IK• 142	IK• 148	
093 C-N-020	INS 108/04		4.0	IK• 061	IK• 062	IK• 063	
093 C-N-030	INS 108/04		4.0	IK• 061	IK• 062	IK• 063	
093 C-L-030	INS 172/10		10.0	IK• 121	IK• 122	IK• 128	
093 C-N-040	INS 172/16		16.0	IK• 141	IK• 142	IK• 148	
093 C-N-060	INS 172/25		25.0	IK• 161	IK• 162	IK• 168	
093 D-N-015	INS 172/06		6.0	IK• 101	IK• 102	IK• 108	
093 D-N-020	INS 172/10		10.0	IK• 121	IK• 122	IK• 128	
093 D-N-030	INS 172/10		10.0	IK• 121	IK• 122	IK• 128	
093 D-N-040	INS 172/25		25.0	IK• 161	IK• 162	IK• 168	

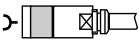
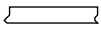
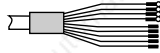
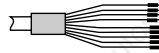
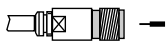

Continued on next page

1) For coupling connector mate: motor power connector

Servo motor MDD ...	Cooling mode	Motor power connector	Motor power cable mm ²	Cable end for ...			
				Connection to drive using a terminal bolt (e.g.. DDS 2)	Intermediate clamp on terminal strip or connection to drive using terminal clamp (e.g.. DKS. DDS 3. DKC)	Intermediate connection using coupling 1)	
							
112 A-N-015	natural convection	INS 108/06	1.0	IK• 011	IK• 012	IK• 003	
112 A-N-020		INS 108/02	1.5	IK• 021	IK• 022	IK• 023	
112 A-N-030		INS 108/02	1.5	IK• 021	IK• 022	IK• 023	
112 A-N-040		INS 108/03	2.5	IK• 041	IK• 042	IK• 043	
112 B-N-015		INS 108/02	1.5	IK• 021	IK• 022	IK• 023	
112 B-N-020		INS 108/03	2.5	IK• 041	IK• 042	IK• 043	
112 B-N-030		INS 108/04	4.0	IK• 061	IK• 062	IK• 063	
112 B-L-030		INS 172/25	4.0	—	—	—	
112 B-N-040		INS 172/06	6.0	IK• 101	IK• 102	IK• 108	
112 C-N-015		INS 108/03	2.5	IK• 041	IK• 042	IK• 043	
112 C-N-020		INS 108/04	4.0	IK• 061	IK• 062	IK• 063	
112 C-L-020		INS 172/25	4.0	—	—	—	
112 C-N-030		INS 172/06	6.0	IK• 101	IK• 102	IK• 108	
112 C-N-040		INS 172/10	10.0	IK• 121	IK• 122	IK• 128	
112 C-N-060		INS 172/25	25.0	IK• 161	IK• 162	IK• 168	
112 D-N-015		INS 108/04	4.0	IK• 061	IK• 062	IK• 063	
112 D-L-015		INS 172/25	4.0	—	—	—	
112 D-N-020		INS 172/06	6.0	IK• 101	IK• 102	IK• 108	
112 D-N-030		INS 172/10	10.0	IK• 121	IK• 122	IK• 128	
112 D-N-040		INS 172/25	25.0	IK• 161	IK• 162	IK• 168	
112 A-N-015		surface cooling	INS 108/06	1.0	IK• 011	IK• 012	IK• 003
112 A-N-020			INS 108/02	1.5	IK• 021	IK• 022	IK• 023
112 A-N-030			INS 108/03	2.5	IK• 041	IK• 042	IK• 043
112 A-N-040			INS 108/04	4.0	IK• 061	IK• 062	IK• 063
112 B-N-015	INS 108/03		2.5	IK• 041	IK• 042	IK• 043	
112 B-N-020	INS 108/04		4.0	IK• 061	IK• 062	IK• 063	
112 B-N-030	INS 108/04		4.0	IK• 061	IK• 062	IK• 063	
112 B-L-030	INS 172/10		10.0	IK• 121	IK• 122	IK• 128	
112 B-N-040	INS 172/16		16.0	IK• 141	IK• 142	IK• 148	
112 C-N-015	INS 108/04		4.0	IK• 061	IK• 062	IK• 063	
112 C-N-020	INS 108/04		4.0	IK• 061	IK• 062	IK• 063	
112 C-L-020	INS 172/06		6.0	IK• 101	IK• 102	IK• 108	
112 C-N-030	INS 172/16		16.0	IK• 141	IK• 142	IK• 148	
112 C-N-040	INS 172/25		25.0	IK• 161	IK• 162	IK• 168	
112 C-N-060	INS 172/25		25.0	IK• 161	IK• 162	IK• 168	
112 D-N-015	INS 108/04		4.0	IK• 061	IK• 062	IK• 063	
112 D-L-015	INS 172/10		10.0	IK• 121	IK• 122	IK• 128	
112 D-N-020	INS 172/16		16.0	IK• 141	IK• 142	IK• 148	
112 D-N-030	INS 172/25		25.0	IK• 161	IK• 162	IK• 168	
112 D-N-040	INS 172/25		25.0	IK• 161	IK• 162	IK• 168	

Continued on next page

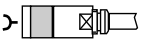
1) For coupling connector mate: motor power connector

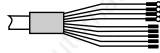
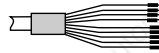
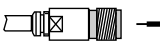
Servo motor MDD ...	Cooling mode	Motor power connector	Motor power cable mm ²	Cable end for ...			
				Connection to drive using a terminal bolt (e.g.. DDS 2)	Intermediate clamp on terminal strip or connection to drive using terminal clamp (e.g.. DKS. DDS 3. DKC)	Intermediate connection using coupling 1)	
							
115 A-N-015	natural convection	INS 108/03	2.5	IK• 041	IK• 042	IK• 043	
115 A-N-020		INS 108/04	4.0	IK• 061	IK• 062	IK• 063	
115 A-L-020		INS 172/25	4.0	—	—	—	
115 A-N-030		INS 172/06	6.0	IK• 101	IK• 102	IK• 108	
115 B-N-015		INS 108/04	4.0	IK• 061	IK• 062	IK• 063	
115 B-L-015		INS 172/25	4.0	—	—	—	
115 B-N-020		INS 172/06	6.0	IK• 101	IK• 102	IK• 108	
115 B-N-030		INS 172/25	25.0	IK• 161	IK• 162	IK• 168	
115 C-N-015		INS 172/06	6.0	IK• 101	IK• 102	IK• 108	
115 C-N-020		INS 172/10	10.0	IK• 121	IK• 122	IK• 128	
115 C-N-030		INS 172/16	16.0	IK• 141	IK• 142	IK• 148	
115 D-N-015		INS 172/06	6.0	IK• 101	IK• 102	IK• 108	
115 D-N-020		INS 172/16	16.0	IK• 141	IK• 142	IK• 148	
115 A-N-015		surface cooling	INS 108/04	4.0	IK• 061	IK• 062	IK• 063
115 A-N-020			INS 108/04	4.0	IK• 061	IK• 062	IK• 063
115 A-L-020			INS 172/06	6.0	IK• 101	IK• 102	IK• 108
115 A-N-030	INS 172/16		16.0	IK• 141	IK• 142	IK• 148	
115 B-N-015	INS 108/04		4.0	IK• 061	IK• 062	IK• 063	
115 B-L-015	INS 172/06		6.0	IK• 101	IK• 102	IK• 108	
115 B-N-020	INS 172/10		10.0	IK• 121	IK• 122	IK• 128	
115 B-N-030	INS 172/25		25.0	IK• 161	IK• 162	IK• 168	
115 C-N-015	INS 172/16		16.0	IK• 141	IK• 142	IK• 148	
115 C-N-020	INS 172/25		25.0	IK• 161	IK• 162	IK• 168	
115 C-N-030	INS 172/25		25.0	IK• 161	IK• 162	IK• 168	
115 D-N-015	INS 172/10		10.0	IK• 121	IK• 122	IK• 128	
115 D-N-020	INS 172/25		25.0	IK• 161	IK• 162	IK• 168	

1) For coupling connector mate: motor power connector

Fig 12.6: Ready-made motor power cable

12.4.4. Order Guidelines

Example: IKL 001 / 12.0

Length in meters

L... standard cable without total shield

F... highly-flexible cable without total shield
(not available with power core diameters
0.75 and 1.5 mm²)

G... cable with total shield

The cables are available in increments of 0.5 meters from five meters and up. Shorter lengths are available upon request.

13. Electrical Motor Feedback Connections

13.1. Terminal Diagram

Terminal diagram for the motors with "resolver feedback"
MDD 021...
MDD 025...
MDD 041...

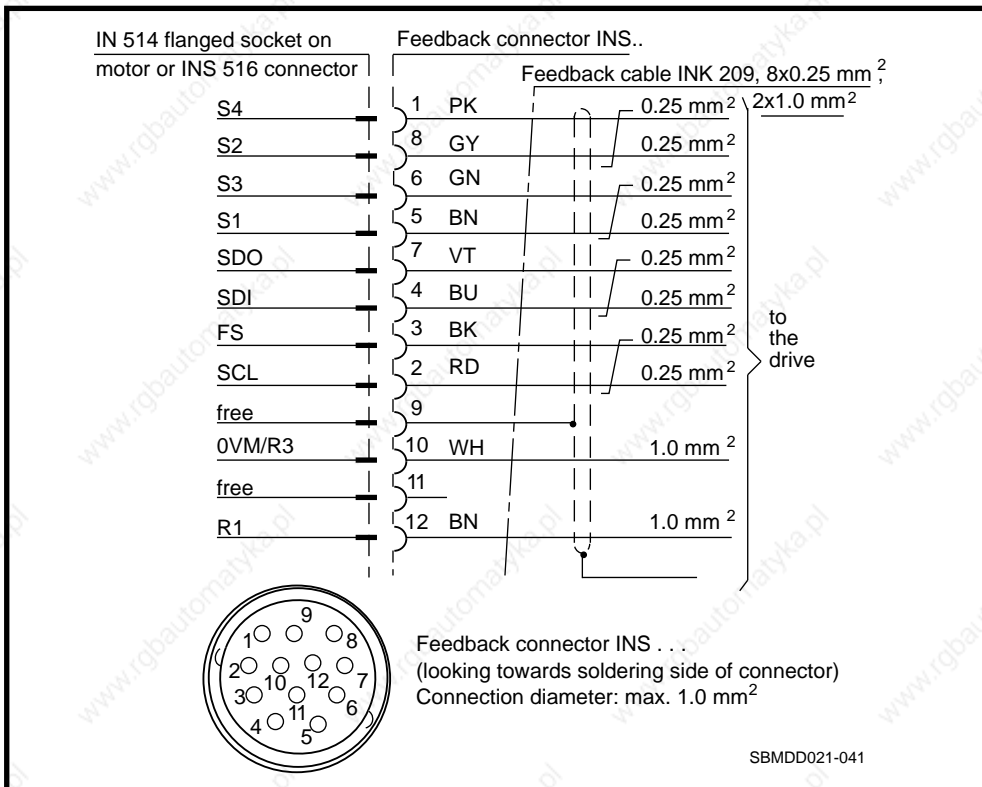

Fig 13.1: Terminal diagram for the motors with "resolver feedback"

Terminal diagram for the motors with "digital servo feedback"
MDD 065...
MDD 071...
MDD 090...
MDD 093...
MDD 112...
MDD 115...

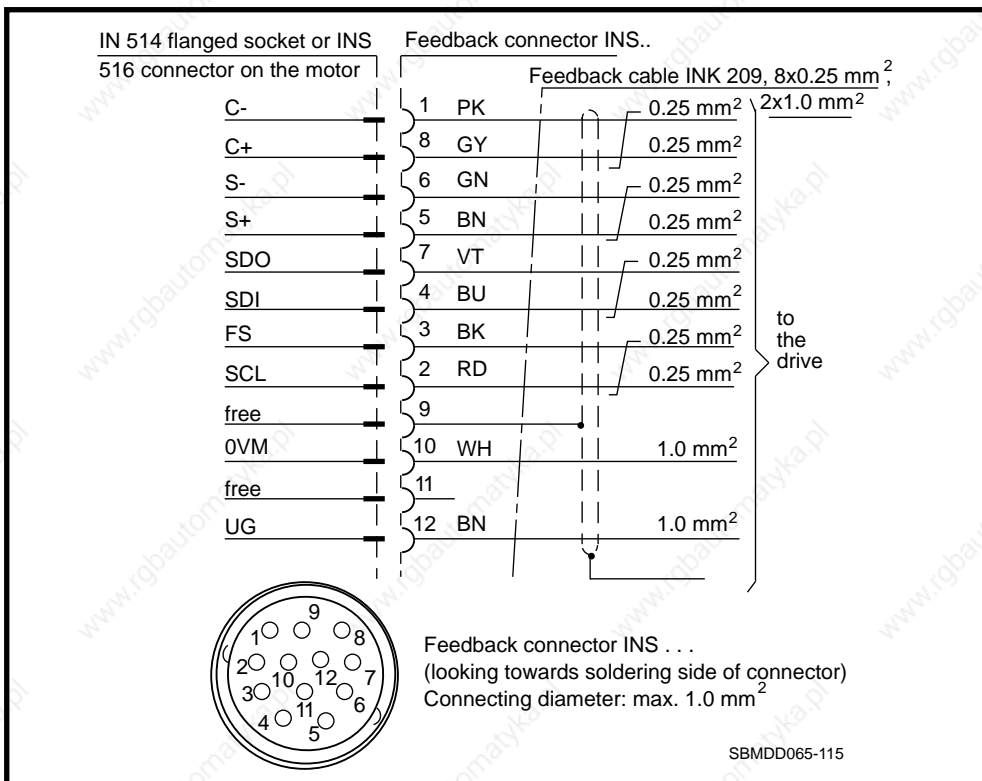

Fig 13.2: Terminal diagram for the motors with "digital servo feedback"



In the event that non-Indramat cables are used, then it is important that the allocation of cores between the flanged socket on the motor and the interface on the drive are absolutely correct. If connections are interchanged and not correctly stranded, then a fail function of the drive becomes highly probable.

13.2. Feedback Connector

Motor type MDD...	Connectors for INDRAMAT cable INK 209		Connectors for cables with an outside diameter of 6 to 10 mm	
	Connector (straight)	Connector (angle)	Connector (straight)	Connector (angle)
021... 025... 041...	INS 513 	—	INS 512 	—
065... 071... 090... 093...	INS 513 	INS 511 	INS 512 	INS 510
112... 115...	INS 513 	INS 511 1) 	INS 512 	INS 510 1)

1) The angle connectors cannot be used with axial surface cooling.

Fig 13.3: The available feedback connectors

13.3. Feedback Cable

13.3.1. Technical Data

Type designation	INK 209
Cable to connector transition protection	IP 65
Cable diameter	8.8 ± 0.3 mm
Minimum bending loads / fixed routing	40 mm
Minimum bending loads / flexible routing (service life = 1 000 000 bending loads)	90 mm
Weight	0.102 kg/m
Permissible ambient temperature for operation and storage	-30 °C to +80 °C
Cable surface	poor adhesion, prevents sticking in drag chains
Chemical features	absolute resistance to mineral oils and greases, hydrolysis resistant, silicone and halogen free
Maximum cable length	75 meters

Fig 13.4: Technical data of feedback cable INK 209

13.3.2. Ready-Made Feedback Cables

Type code for ready-made feedback cables	Feedback connectors	INDRAMAT feedback cables	Cable end design
IKS 374	INS 513	INK 209	INS 439
IKS 375 ²⁾	INS 511	INK 209	INS 439
IKS 376	INS 513	INK 209	INS 516
IKS 377 ²⁾	INS 511	INK 209	INS 516
IKS 378	INS 513	INK 209	with ferrules for connecting to terminal strips
IKS 379 ²⁾	INS 511	INK 209	with ferrules for connecting to terminal strips

Plug-in connector: 15-pin D-Sub for connection to drive

with coupling unit for connecting to INS 513

with ferrules for connecting to terminal strips

- 1) To be avoided due to possible interference in shielding.
- 2) • Not to be used for MDD 021, MDD 025 and MDD 041 motors.
- Do not use in MDD 112 and MDD 115 motors with axial surface cooling.

MZFEEDBACK

Fig 13.5: Ready-made feedback cables

13.3.3. Order Guidelines

Example: IKS 374 / 12.0
 length in meters

Ready-made feedback cables are available in increments of 0.5 meters after a length of five meters. Shorter lengths available upon request.

14. Condition at Delivery

The motors are packed onto a palette or in cartons at the time of delivery. The way they are packed depends upon the numbers and/or sizes of the motor.

If a single motor is packed on a palette, then it is secured against sliding and movement by means of squared timbers and tightly lashed into place with taut metal bands. If several motors are simultaneously delivered, then up to three motors will be on one palette. Pieces of styrofoam or cartons are then used to prevent them from damaging each other.

To prevent damage from inclement weather, a carton is placed over a palette and then affixed to the palette with the use of taut bands.

To unpack without damaging the items, simply cut through the taut bands.



Caution! There is tension in the taut bands!

There exists the danger of injury from the uncontrolled lashing out of the taut bands!

Maintain sufficient distance! Cut taut bands open carefully!

There is an envelope containing the delivery slip attached to the carton.

There is also a barcode sticker (or stickers depending on the extent of the delivery) listing the following information:

- type designations of the motor
- customer
- delivery slip number
- consignment
- name of delivering agent

(See section 15: "Identifying the Merchandise".)

There is no further documentation accompanying the delivery unless specifically requested.

15. Identifying the Merchandise

There is one delivery slip accompanying the entire delivery. This slip lists the merchandise in terms of its name and order designations. In the event that some of the listed items are distributed over several cartons or transport containers, this will be noted in the delivery or freight slip.

Barcode Sticker

There is a barcode sticker on the packaging of the motor. If several motors are in one carton or container, then there is a sticker for each motor.

The sticker helps to identify the contents of the cartons and is required to complete the order procedure at INDRAMAT.

The following information is on the sticker:

- type designation of the motor
- customer
- delivery slip number
- consignment
- name of delivering agent



Fig 15.1: Example of a barcode sticker

Rating Plate The motor is delivered with a name plate attached to the motor housing.

If a second name plate is ordered, then it is placed over the original one with double-sided tape. Both are on the housing of the motor.

INDRAMAT		Build Date 44 / 92	
MDD090C-N-020-N2L-110GB0/S016			
S.No. 123456	Com.No. 234567	Part No. 345678	
			
natural convection	surface cooled	I.Cl. F	IP 65
Tcont 10.4 Nm	16.0 Nm	n 2000 min ⁻¹	
IdN 9.5 A	14.6 A	Km 1.10 Nm/A	
		m 50 kg	
Brake 14.0 Nm	24 V ± 10 %		0,75 A
Made in Germany			

Fig 15.2: Example of a name plate of an MDD AC servo motor per DIN 42961

16. Storage, Transport and Handling

There are guidelines on storage and transportation printed on the carton. These must be followed.



Fig 16.1: Guidelines on storage and transport on packaging

Storing the Motors

The motors must be stored in a dry, dust-free and shock-free environment.

Permissible temperature range: -25 °C to + 85 °C.

There are protective covers on the connector housing as well as the output shaft. These are made of plastic and protect the parts they cover against moisture and damage. Do not remove the protective covers until shortly prior to mounting into the machine.

Transport and Handling

Avoid impacts to the output shaft and heavy loads as otherwise the bearings in the motor could be damaged.

Note the different weights and sizes of the individual types of motors when selecting both the transport and lifting devices.



Do not pick up the motor at the blower. This will damage and possibly tear the blower off of the motor housing.

Figure 16.2 depicts how the heavy motors should be picked up with the help of a crane and belts. It is important that no load is applied to either output shaft or blower housing during this procedure!

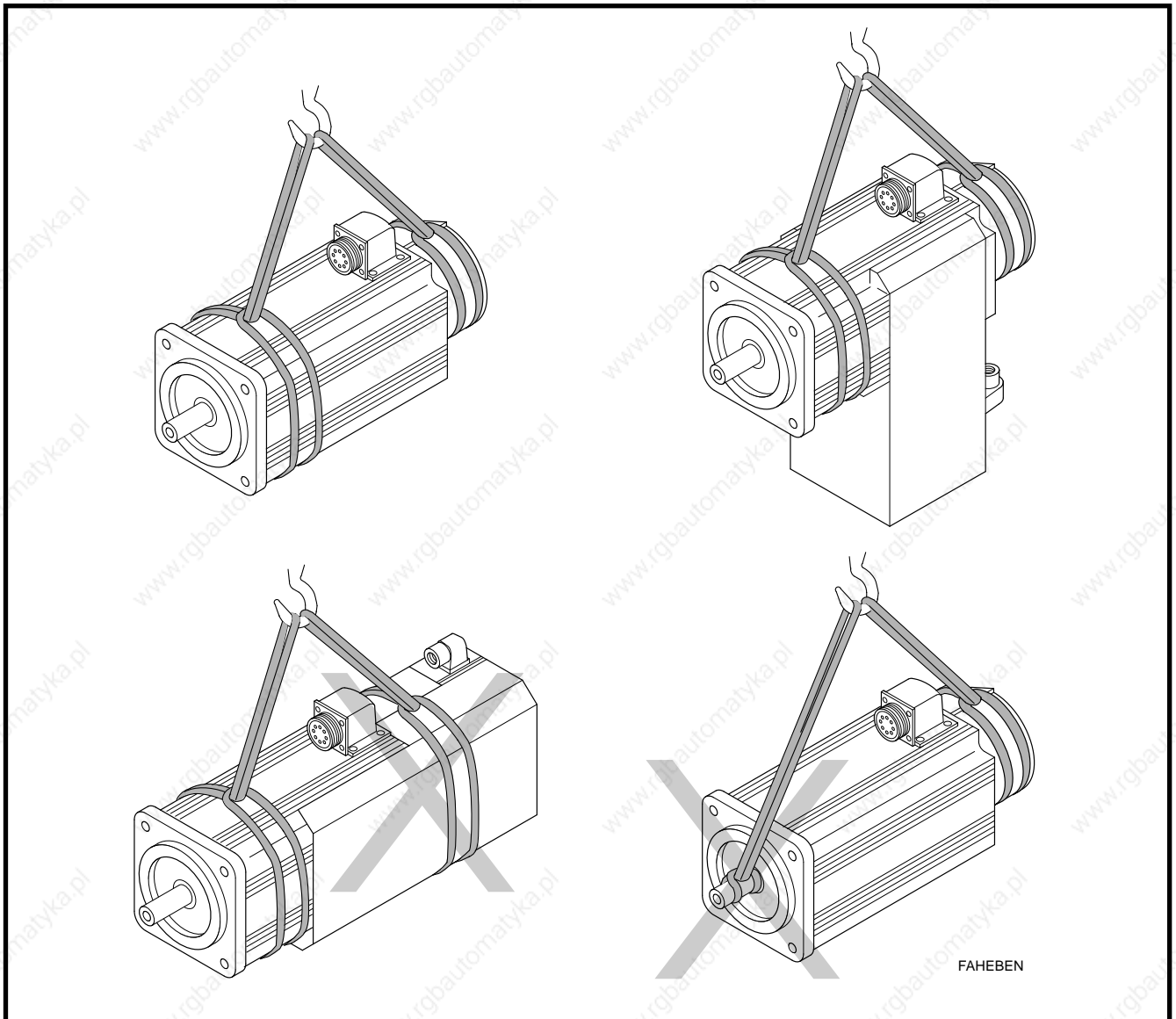

Fig 16.2: Picking up and transporting the motors with the help of the crane belts

There are two M8 tapped holes in the housing of the MDD 112 and MDD 115 line of motors. Lifting screws (per DIN 580) can be screwed into place here. These can then be used by for holding the motor in place by a suitable lifting device. The hooks of a chain tackle can, for example, be hooked into place here. (See Figure 16.3).

INDRAMAT does not automatically deliver these lifting screws with the motor. The user must, therefore, supply them.



If a blower for axially surface-cooling the motors of the MDD 112 and MDD 115 line is mounted, then these *may only* be picked up by the lifting screws.

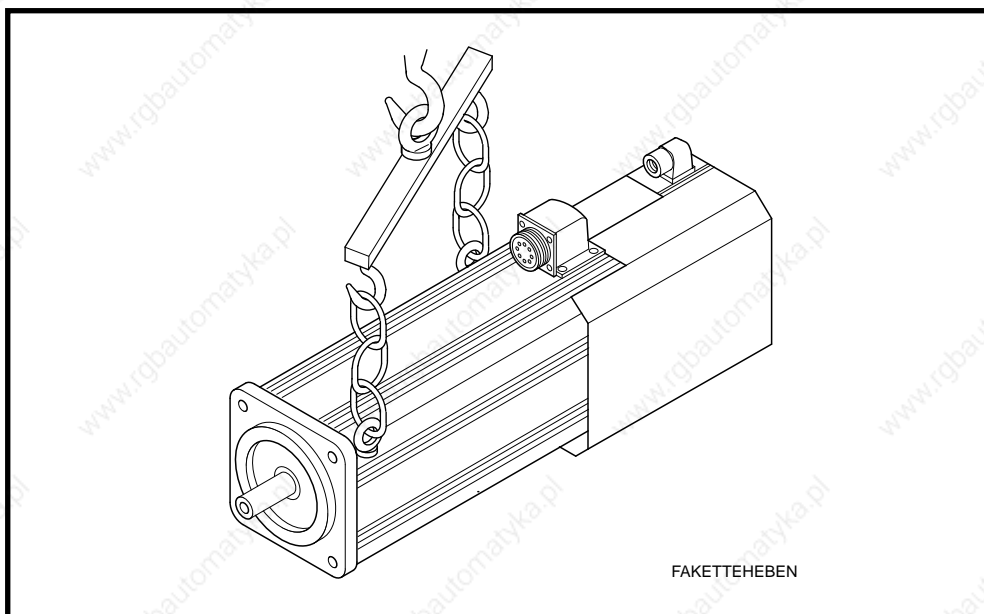

Fig 16.3: Picking up and transporting MDD 112 or MDD 115 motors with chain tackle

17. Mounting and Installation Guidelines

The following guidelines must be followed to avoid damaging the machine during mounting and commissioning.

- The bigger and thus heavier motors may only be transported with the use of suitable lifting devices as described in the guidelines of Section 16.
- Avoid impacts to the output shaft and heavy loads at the shaft as otherwise the bearings within the motor could be damaged.
- The motors should only be mounted to the machine by fully trained personnel.
- The spigot nuts on the connectors (motor power and feedback connectors) must be tightly screwed into place when connecting.
- The motor must be grounded to the drive amplifier.
- The terminal diagrams of the machine manufacturer should be followed when wiring the motor!
- The motor as well as machine/facility may only be started up by a fully trained electrician or personnel under the supervision of an electrician.

18. Service Guidelines

18.1. Contacting Customer Service

INDRAMAT customer service can be reached at the following Service Hotline Numbers:

Service Hotline Phone no.: 0172-6600406 or 0171-3338826

Monday - Friday 7 a.m. to 11 p.m. MEZ
Saturday 8 a.m. to 8 p.m. MEZ
Sundays and holidays 9 a.m. to 7 p.m. MEZ

We would appreciate your noting the following information prior to contacting INDRAMAT customer service:

- type data of motor and drive
- the problem
- all fault and diagnostics displays

This will make it possible to quickly and definitively locate the problem.

When returning a motor, please include a copy of the repair card. This can be copied from the example on the next page. Fill it out and send it in. This will enable us to locate the problem caused by this particular application.

18.2. Repair Card

Repair Report Card for INDRAMAT equipment and components			
Name:		Company/Location:	
Date:			
Part number for exchange of single parts		SN:	Consignment no.:
		SN:	Delivery date:
Machine manufacturer/co.:	Type:	Machine no.:	Commissioning date:
Failure in axis:	<input type="checkbox"/> horizontal <input type="checkbox"/> vertical <input type="checkbox"/>	Operating time:	Date fault occurred:
Fault: Fault _____ _____ <input type="checkbox"/> constantly present <input type="checkbox"/> occurs sporadically <input type="checkbox"/> occurs after _____ hrs. <input type="checkbox"/> occurs with shocks <input type="checkbox"/> depends on temperature <input type="checkbox"/> other _____ _____ _____	Additional data: (e.g., LED diagnosis, error in display) _____ _____ _____ _____ _____ _____ _____	Cause of fault: <input type="checkbox"/> unknown <input type="checkbox"/> connection fault <input type="checkbox"/> external short circuit <input type="checkbox"/> mechanical damage <input type="checkbox"/> loose cable(s) <input type="checkbox"/> other _____ _____ _____	
Additional Data			
General data: <input type="checkbox"/> no function <input type="checkbox"/> drive not running smooth <input type="checkbox"/> uncontrolled drive motions <input type="checkbox"/> error in one direction only <input type="checkbox"/> supply unit short-circuit fault <input type="checkbox"/> other	Concomitant phenomena: <input type="checkbox"/> Problems in mechanical sys. <input type="checkbox"/> Mains failure <input type="checkbox"/> Control failure <input type="checkbox"/> Motor failure <input type="checkbox"/> Break in cable <input type="checkbox"/> other	Drive, supply unit, amplifier, power section <input type="checkbox"/> control voltage faulty <input type="checkbox"/> power sect. circuit breaker F ____ <input type="checkbox"/> blower defective <input type="checkbox"/> bleeder resistor defective <input type="checkbox"/> power voltage faulty <input type="checkbox"/> connecting bolt broke <input type="checkbox"/> other	
Control: <input type="checkbox"/> no function <input type="checkbox"/> display failed <input type="checkbox"/> no command value output <input type="checkbox"/> diagnosis <input type="checkbox"/> dim. offset in _____ direction <input type="checkbox"/> E-stop loop interrupted <input type="checkbox"/> position control loop won't close <input type="checkbox"/> program sequence fault <input type="checkbox"/> interior auxiliary function faulty (outputs) <input type="checkbox"/> acknowledgements not accepted (inputs) <input type="checkbox"/> other _____ _____	Motor: <input type="checkbox"/> temperature monitoring defective <input type="checkbox"/> brake defective <input type="checkbox"/> blower defective <input type="checkbox"/> feedback defective <input type="checkbox"/> tachometer signal faulty <input type="checkbox"/> BLC-signal faulty <input type="checkbox"/> short-circuit to ground <input type="checkbox"/> thermal overload <input type="checkbox"/> other _____ _____ _____	Comments: _____ _____ _____ _____ _____	

PIRepBegI

Fig 18.1: Repair Card

19. Index

A

Absolute position detection 10, 25
absolute position detection 25
Ambient conditions 12
Angle connector 22
Applications 7
Axial shaft load 18
Axial surface cooling 19

B

Balance class 21
Barcode Sticker 139
Blocking brake 10, 20

C

Connector to Cable Allocation 122
Connector to cable allocation 122
Construction 9
Construction and mounting orientation 16
Construction/mounting orientation 16
Contacting Customer Service 145
Cooling 10
Crimping 24

E

Electrical Connections 11
Electrical Features 23
Electrical Motor Feedback Connections 135
Electrical power connection 121

F

Feedback 24
Feedback Cable 136
Feedback Connection 136
Feedback connection 24
Feedback connector 22
Feedback storage 26

H

Housing coat 15

I

Identifying the Merchandise 139
Installation elevation 12
Installation elevation and ambient temperatures 12
Installation on the motor 10

M

MDD 021 29
MDD 025 36
MDD 041 46
MDD 065 54
MDD 071 64
MDD 090 74

MDD 093 83
MDD 112 96
MDD 115 110
Mechanical ambient conditions 14
Montage- und Installationshinweise 144
Motor 128
Motor blower connection 24
Motor feedback 10, 25
Motor Power Cable 128
Motor power connector 127

O

Operating reliability 9
Output shaft 10, 17
Output shaft with keyway 17

P

Performance data 10
Permissible shaft load 18
Permissible radial force 18
Permissible shaft load 18
Pilot diameter 17
Plain output shaft 17
Plain shaft 10
Plain output shaft 17
Power connection 21, 24
Power levels 8
Protection 12
Protection category 12

R

Radial shaft load 18
Radial surface cooling 19
Rating 140
Rating Plate 140
Ready-Made Feedback Cables 137
Ready-made motor power cable 129
Relative position detection 10, 25
Repair Card 146

S

S1-continuous operating curve 28
S6-intermittent operating curve 28
Service 145
Service Guidelines 145
Service Hotline 145
Shaft 18
Shaft Load Capacities 31
Shaft Load Capacity 39, 49, 59, 69, 79, 91, 105, 117
Shaft sealing ring 18
Shafts with keyways 10
Soldering 24
Storage 141
Storage, Transport and Handling 141
Straight Connector 22
Straight connector 22

T

Technical Data	29
Terminal Diagram	121
Terminal diagram	23
Thermal Deformations	18
Thermal deformations	18
Torque-Speed Characteristic Curves	27
Torque-Speed Characteristics Curve	76, 85, 98
Torque-Speed Characteristics Curves	30, 37, 47, 56, 66
Torque-Speed Characteritics Curve	112

