

COMBIVERT



F4

0,75...160 kW

D

BETRIEBSANLEITUNG

Leistungsteil

GB

INSTRUCTION MANUAL

Power Circuit

E

MANUAL DE INSTRUCCIONES

Circuito de Potencia

I

MANUALE D'ISTRUZIONE

Circuito di potenza

RU

Руководство по эксплуатации

Силовая часть

F

MANUEL D'INSTRUCTIONS

Circuit de Puissance



Erst Betriebsanleitung Teil 1 lesen !
Read Instruction manual part 1 first !
Leer manual de instrucciones parte 1 antes !
Prima leggere le manuale di istruzione 1 parte !
Сначала прочти инструкцию 1 часть !
Lisez d'abord le manuel d'instructions partie 1 !

KEB

D

Seite D - 3 D - 40

Diese Betriebsanleitung muß jedem Anwender zugänglich gemacht werden. Vor jeglichen Arbeiten muß sich der Anwender mit dem Gerät vertraut machen. Darunter fällt insbesondere die Kenntnis und Beachtung der Sicherheits- und Warnhinweise. Die in dieser Betriebsanleitung verwendeten Pictogramme entsprechen folgender Bedeutung:



**Gefahr
Warnung
Vorsicht**



**Achtung,
unbedingt
beachten**



**Information
Hilfe
Tip**

GB

Page GB - 3 GB - 40

This instruction manual must be made available to any user. Before working with this unit the user must be familiarized with it. This is especially true for the attention, safety and warning guides. The meaning of the pictograms used in this manual are:



**Danger
Warning
Caution**



**Attention,
observe at
all costs**



**Information
Help
Tip**

E

Páginas E - 3 E - 40

Este manual de instrucciones debe estar a disposición de cualquier usuario. Antes de manipular el convertidor el usuario debe familiarizarse con él. Esto debe aplicarse especialmente al conocimiento de las indicaciones de advertencia y seguridad. El significado de los pictogramas usados en este manual son:



**Peligro
Advertencia
Precaución**



**Atención,
Cuidado**



**Consejo
Comentario
Información**

I

Page I - 3 I - 40

Prima di eseguire qualsiasi lavoro sull'unità l'utente deve familiarizzare con l'apparecchiatura. Questo comprende, specialmente, la conoscenza e le osservanze delle direttive di sicurezza e di avvertimento sottorincontrate. I simboli usati in questo Manuale di Istruzione hanno il seguente significato:



**Avvertimento
Pericolo
Cautela**



**Attenzione,
osservare
assolutamente**



**Informazione
Aiuto
Suggerimento**

RU

Страницы RU-3...RU-40

Эта инструкция должна быть доступна для каждого пользователя. Прежде чем приступить к работе каждый пользователь должен тщательно ознакомиться с прибором. Особенно это касается знаний по технике безопасности. Ниже приведённые пиктограммы означают следующее:



**Опасность
Предупреждение
Осторожно**



**Внимание
обязательно
соблюдать**



**Совет
Указание
Информация**

F

Page F - 3 F - 40

Ce manuel d'instructions doit être rendu accessible à tout utilisateur. Avant tous travaux, l'utilisateur doit se familiariser d'abord avec le variateur, notamment tenir compte des mesures de sécurité et des avertissements. Les pictogrammes utilisés dans ce manuel ont les significations suivantes:



**Danger
Avertissement
Précaution**



**Attention,
à respecter
obligatoirement**



**Information
Aide
Astuces**

Table of Contents

1. General	4
1.1 Product Description	4
1.2 Rating plate	5
1.3 Installation Instructions	6
1.3.1 RCD (FI-Protective Switch)	7
1.4 Control Cabinet Installation	8
1.5 DC-supply	8
2. Technical Data	9
2.1 Summary of the Technical Data 230V Class	9
2.2 Summary of the Technical Data 400V Class	10
2.3 Dimensions and Weight	14
2.4 Summary of the Power Circuit Connections	16
2.5 Connection of the Power Circuit	18
3. Accessories	20
3.1 Braking Resistors	20
3.1.1 Side mounting braking resistor	22
3.1.2 Parallel connection of braking resistors	24
3.1.3 Submounting braking resistor	25
3.2 Input filter	29
3.2.1 Input choke	29
3.2.2 HF filter	31
3.3 Output filter	35
3.3.1 Output choke	35
3.3.2 Sinus filter	37
3.3.3 Sinus filter plus	39
4. Annex	40
4.1 Overload curve	40
4.2 Overload protection in the lower speed range	40

1. General

1.1 Product Description

In selecting the KEB COMBIVERT you have chosen a frequency inverter with the highest demands for quality and dynamic.



It is exclusively for a stepless speed regulation of a three-phase motor.



The operation of other electrical loads is forbidden and can lead to disturbances of the unit.

This manual describes the power circuit for **KEB COMBIVERT F4-S, F4-C and F4-F** frequency inverters in the range of

- **0.75 kW...30 kW / 230V class**
- **0.75 kW...160 kW / 400V class**



The power circuits of the frequency inverters in the W-housing (**200 kW...315 kW**) are described in an additional instruction manual (part no. 00.F4.01Z-KWxx).

Not only is this unit small in size and in price, it also has the following features:

- with IGBT power circuits there are only slight switching losses
- slight noise on high switching frequency
- extensive safety device for current, voltage and temperature
- voltage and current monitoring in static and dynamic operation
- conditionally short circuit proof and earth-fault proof
- noise immunity in accordance with IEC1000
- hardware current regulation
- integrated cooling fan
- uniform mounting grid
- can be aligned next to each other using the rack

1.3 Installation Instructions

- Install KEB COMBIVERT stationary and ground.
- Take into consideration the minimum distance surrounding elements when positioning the inverter (see enclosed cabinet).
- Rack units are designed for vertical installation and can be aligned next to each other. Maintain a distance of at least 50mm to the elements stored in front. Make sure cooling is sufficient.
- No mist or water may get into the KEB COMBIVERT.
- Prevent dust from getting into the KEB COMBIVERT.
When installing a dust-proof housing make sure it has enough heat dissipation.
- Do not operate KEB COMBIVERT in an explosion-protected room! In explosion-protected rooms the KEB COMBIVERT must be installed in an explosion protected housing, in observance of the local regulations.
- Protect KEB COMBIVERT against conductive and aggressive gases and liquids.
- Consumers, which produce electrical or magnetic fields or have an influence on the voltage supply, must be placed as far away as possible and measures must be taken to suppress the influences.
- when installing COMBIVERT in the proximity of trafo or transformer stations we urgently recommend to connect in series a line reactor. Through high Rsc-values ($R_{sc} = \text{short-circuit power} / \text{apparent power}$) the intermediate circuit capacitors can age above average and lead to a defect. Guide values according to IEC 1000-2-6:
Rsc < 100: no reactor necessary
Rsc = 100...200: a reactor is recommended if the load exceeds 75 % permanently
Rsc > 200: reactor is necessary
- Regarding applications, that require cyclic switching off and on of the static frequency inverter, a minimum time-out of at least 5 minutes must be kept after power-off. If shorter cycle times are needed, please contact KEB.

GB

1.3.1 RCD (FI-Protective Switch)

If personnel protection is required during installation of the system the frequency inverters must be protected according to EN 50178 (VDE 0160):

- 1-phase inverters by RCD type A (pulse-current sensitive FI's) or type B (all-current sensitive FI's)
- 3-phase inverters (with B6 bridge-connected rectifier) by RCMA's with separation (used privileged) or RCD's type B (all-current sensitive FI's)

The tripping current should be 300mA or more, in order to avoid a premature triggering of the inverter by discharge currents (about 200mA).

Dependent on the load, the length of the motor cable and the use of a radio interference filter, substantially higher leakage current can occur.

The connection instructions from the manufacturer and the valid local requirements must be observed. Dependent on the available mains form (TN, IT, TT) further protective measures are necessary in accordance with VDE Part 410 (Part 4; Chapter 41). For example, with TN-mains this protection is made with overcurrent protective devices. With IT-mains it is insulation monitoring with a pulse-code measuring method. A protective separation can be used with all mains forms as long as the required power and cable lengths permit this.

Diagram of a distribution board (principle of protective elements)

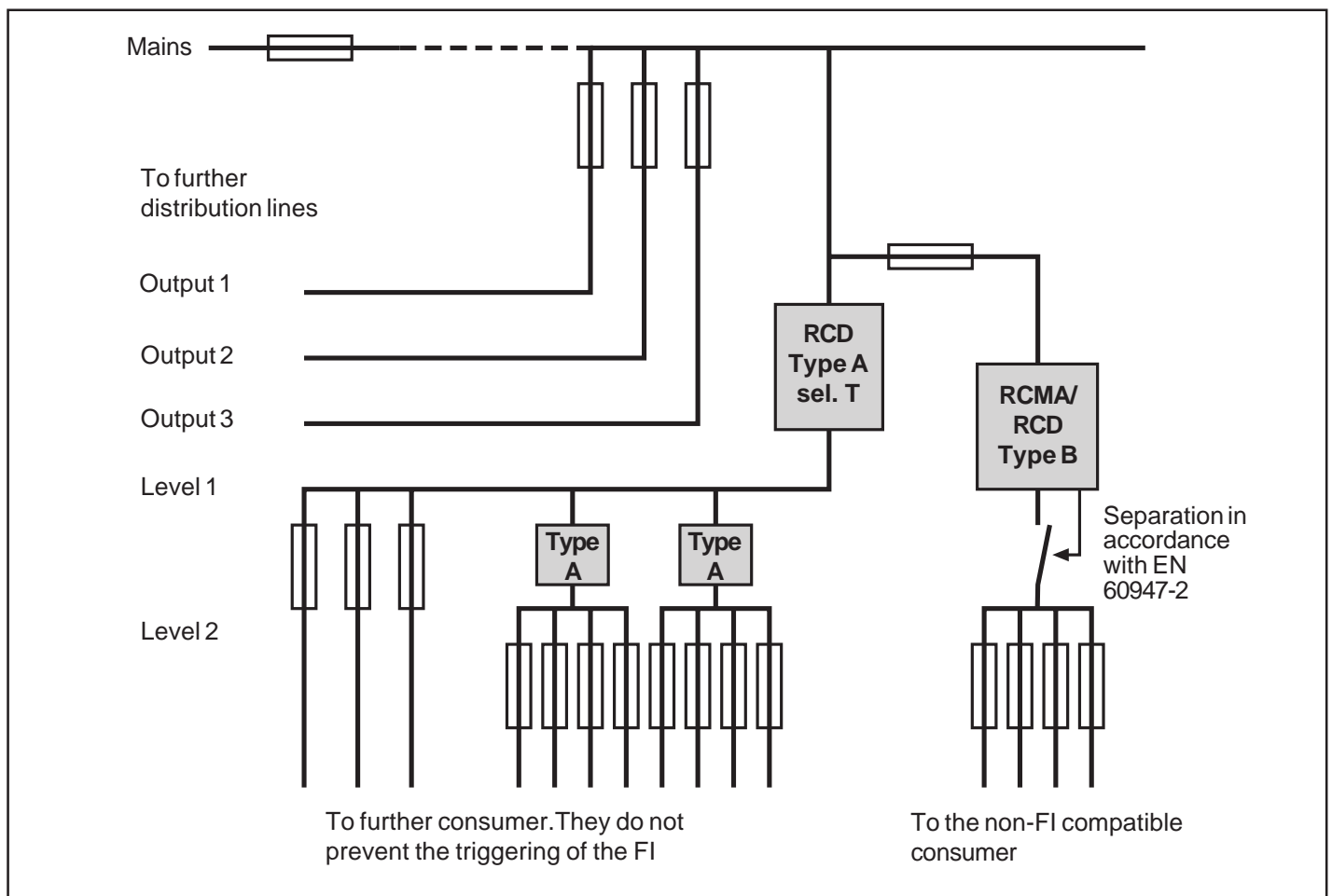

1.4 Control Cabinet Installation

GB

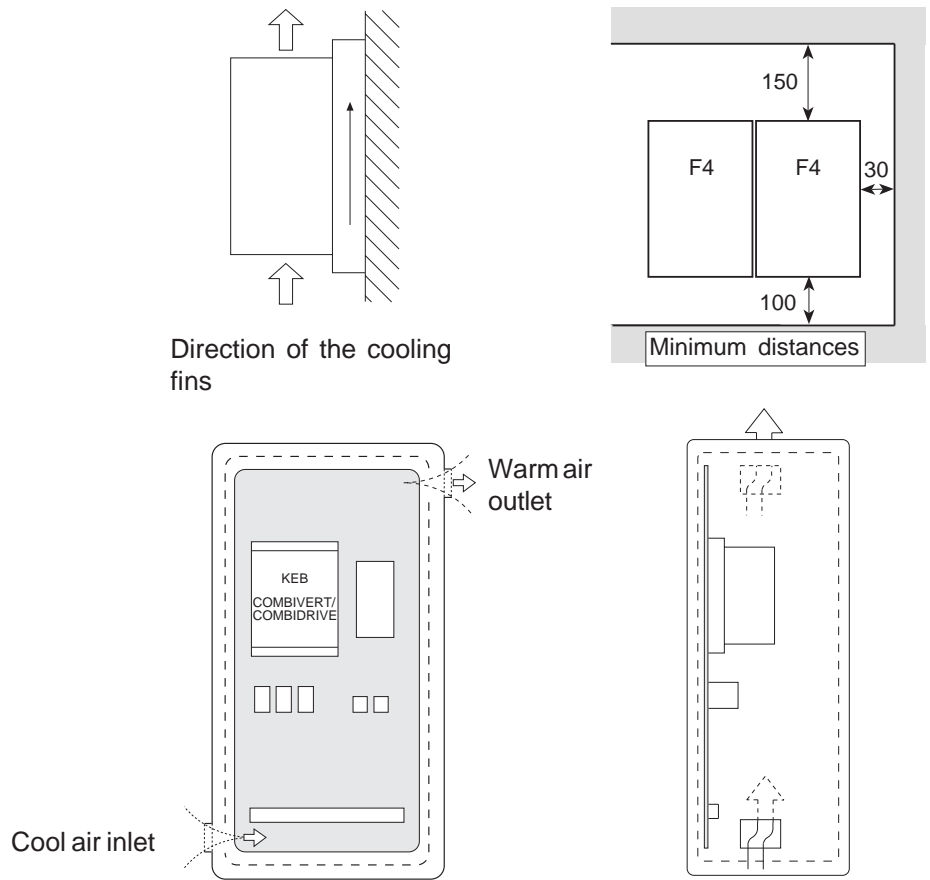

1.5 DC-supply

The **DC input current** of the inverter is basically determined by the used motor. The data can be taken from the motor name plate.

230V Class:

$$\frac{\sqrt{3} \times \text{rated motor voltage} \times \text{rated motor current} \times \text{motor } \cos \varphi}{310V}$$

400V Class:

$$\frac{\sqrt{3} \times \text{rated motor voltage} \times \text{rated motor current} \times \text{motor } \cos \varphi}{540V}$$

The **DC input peak current** is determined by the operating range.

- if you accelerate on the hardware current limit, the short-time limit current of the inverter must be set in the formula above (instead rated motor current).
- if the motor in normal operation is never stressed with rated torque, it can be calculated with the real motor current.
- a good value agrees with approx. 1,5 times of the rated motor current (from 90kW 1,25-times)

2. Technical Data

2.1 Summary Technical Data 230V Class

Inverter Size		07	09	10	13	14	15	16	17	18	19	20	21				
Output nominal power	[kVA]	1,6	2,8	4	9,5	13	19	26	33	40	46	59	71				
Max. rated motor power	[kW]	0,75	1,5	2,2	5,5	7,5	11	15	18,5	22	30	37	45				
Output nominal current	[A]	4	7	10	24	33	48	66	84	100	115	145	180				
Max. short-time current ¹⁾	[A]	7,2	12,6	18	36,5	49,5	72	99	126	150	172	217	270				
OC-tripping current	[A]	8,8	15	22	43	59	88	119	151	180	206	261	324				
Nominal input current	[A]	8 4	14 7,7	20 11	26,5	36	53	73	92	116	126	165	198				
Housing size		D	D	D	E	G	G	H	H	R	R	R	R				
Rated operating frequency ²⁾	[kHz]	16	8	16	4	16	16	16	16	8	8	8	8				
Max. operating frequency	[kHz]	16	8	16	4	16	16	16	16	8	8	8	8				
Power loss at nominal operating	[W]	65	70	135	165	220	280	430	550	850	1020	1200	1350				
Stall current at 8kHz	[A]	-	-	-	-	24	33	48	66	84	100	115	145				
Stall current at 16kHz	[A]	-	-	-	-	24	33	48	66	-	-	-	-				
Max. heat sink temperature T _{OH}	[°C]	85	85	85	73	90	90										
Max. permissible mains fuse (inert)	[A]	20 10	20 10	25 20	35	50	80	80	100	160	160	200	315				
Line cross section	[mm ²]	2,5 1,5	2,5 1,5	4,0 2,5	6	10	25	25	35	50	50	95	95				
Min. braking resistor ³⁾	[Ω]	56	56	28	18	16	13	5,6	5,6	4,7	4,7	3,9	2,0				
Typ. braking resistor ³⁾	[Ω]	180	100	68	27	20	13	10	7	5,6	4,7	3,9	3,0				
Max. braking current	[A]	7	7	14	21	29	29	70	70	85	85	102	160				
Overload curve (Page 40)		1															
Tightening torque for terminals	[Nm]	0,5			1,2			2,5			6			15			
Wiring diagram (Page 18/19)		1	2	1	2	1	2	3	4	4	4	4	3	3	3	3	3
Mains voltage (Rated voltage)	[V]	180...260 +/-0 (230V)															
Phases		1	3	1	3	1	3	3	3	3	3	3	3	3	3	3	
Mains frequency	[Hz]	50 / 60 +/- 2															
Output voltage (U _N =Mains voltage)	[V]	3 x 0...U _N															
Output frequency	[Hz]	0...409,58 (0...819,16; 0...1638,32)															
Shielded motor line length	[m]	30	30	50	50	100				50							
Storage temperature	[°C]	-25...70															
Operating temperature	[°C]	-10...45															
Model / protective system		IP20															
Relative humidity (without condensation)	[%]	max. 95															
EMC tested in accordance with...		EN 61800-3															
Climatic category (EN 50178)		3K3															
Mains choke (s. page 29)		3	4	5	6	7	8	11	12	13	15	16	17	17	19	19	
Motor choke (s. page 35)		4	6	8	11	12	13	14	15	16	17	18	19				
HF-Filter assembly kit (s. page 31)		1	4	2	4	3	5	6	7	7	8	9	10	11	11	12	13
Sine filter (s. page 37)		1	2	3	5	6	9	-	-	-	-	-	-				

- 1) For F4F-Types 5% must be subtracted as control reserve
- 2) For F4F-Types generally a operating frequency of min. 8 kHz is valid (for 16 kHz version ask KEB).
- 3) The statement counts only for frequency inverters with internal braking transistor (see "Rating Plate").

The technical data is for 2/4 pole standard motors. With other pole numbers the inverter must be dimensioned onto the motor rated current. Contact KEB for special or medium frequency motors.

Site altitude max. 2000 m. With site altitudes over 1000 m a power reduction of 1% per 100m must be taken into consideration.

2.2 Summary of Technical Data 400V Class (<= Size 17)

Inverter Size		07	09	10	12	13				
Output nominal power	[kVA]	1,8	2,8	4	6,6	8,3				
Max. rated motor power	[kW]	0,75	1,5	2,2	4	5,5				
Output nominal current	[A]	2,6	4,1	5,8	9,5	12				
Max. short-time current ¹⁾	[A]	4,6	7,4	10,4	17,1	21,6	18			
OC-tripping current	[A]	5,7	9	12,7	20,9	26,4	21,6			
Nominal input current	[A]	2,8	4,5	6,4	10,5	13,2				
Housing size		D	D	D	D	D	E	D	E	G
Rated operating frequency ²⁾	[kHz]	4	4	4	12	4	16	2	16	
Max. operating frequency	[kHz]	4	4	4	12	4	16	4	16	
Power loss at nominal operating	[W]	45	60	80	130	115	180	135	240	200
Stall current at 8kHz	[A]	-	-	-	6,4	-	9,5	-	12	19
Stall current at 16kHz	[A]	-	-	-	-	-	9,5	-	12	12
Max. heat sink temperature T _{OH}	[°C]	85		79	85	73	79	73	90	
Max. permissible mains fuse (inert)	[A]	10		10	20	20				
Line cross section	[mm ²]	1,5		1,5	2,5	2,5				
Min. braking resistor ³⁾	[Ω]	160		160	82	50	82	50	39	
Typ. braking resistor ³⁾	[Ω]	680	390	270	150	110				
Max. braking current	[A]	5			10	15	10	15	21	
Overload curve (Page 40)		1								
Tightening torque for terminals	[Nm]	0,5								1,2
Wiring diagram (Page 18/19)		2				3	2	3	4	
Mains voltage (Rated voltage) ⁴⁾	[V]	305...500 +/-0 (400V)								
Phases		3								
Mains frequency	[Hz]	50 / 60 +/- 2								
Output voltage (U _N =Mains voltage)	[V]	3 x 0...U _N								
Output frequency	[Hz]	0...409,58 (0...819,16; 0...1638,32)								
Shielded motor line length	[m]	50	50	100	100	100				
Storage temperature	[°C]	-25...70 °C								
Operating temperature	[°C]	-10...45 °C								
Model / protective system		IP20								
Relative humidity (without condensation)	[%]	max. 95								
EMC tested in accordance with...		EN 61800-3								
Climatic category (EN 50178)		3K3								
Mains choke (s.page 29)		19	20	21	23	23				
Motor choke (s.page 35)		19	20	20	22	23				
HF-Filter assembly kit (s. page 31)		10	10	10	11	12	11	12	14	
Sine filter (s. page 37)		1	1	2	2	-	3			
Sine filter plus (s. page 39)		-	-	-	2	-	3	-	3	

- 1) For F4F-Types 5% must be substrated as control reserve
- 2) F4-F units need a power circuit with rated operating frequency of min. 8kHz.
- 3) This data is only valid for units with internal brake transistor (see "unit identification").
- 4) At mains voltage ≥460V multiply the nominal current with factor 0,86.

Inverter Size		14		15			16		17		
Output nominal power	[kVA]	11		17			23		29		
Max. rated motor power	[kW]	7,5		11			15		18,5		
Output nominal current	[A]	16,5		24			33		42		
Max. short-time current ¹⁾	[A]	29,7	24,8	36			49,5		63		
OC-tripping current	[A]	36,3	29,7	43,2			59,4		75,6		
Nominal input current	[A]	18,1		26,5			36,5		46		
Housing size		E		G		H		R		R	
Rated operating frequency ²⁾	[kHz]	8	16	4	8	16	8	16	4	8	16
Max. operating frequency	[kHz]	16	16	12	16	16	16	16	16	16	16
Power loss at nominal operating	[W]	240	260	260	290	360	310	490	360	470	700
Stall current at 8kHz	[A]	16,5	19	-	19	25	21,5	33	-	30	42
Stall current at 16kHz	[A]	-	12	-	8,5	15	9,7	20	-	13,5	30
Max. heat sink temperature T _{OH}	[°C]	73	90	73	90						
Max. permissible mains fuse (inert)	[A]	25		35			50		63		
Line cross section	[mm ²]	4		6			10		16		
Min. braking resistor ³⁾	[Ω]	50	39	39		22	25	22	25	22	9
Typ. braking resistor ³⁾	[Ω]	85		56			42		30		
Max. braking current	[A]	15	21	21		37	30	37	30	37	88
Overload curve (Page 40)		1									
Tightening torque for terminals	[Nm]	0,5	1,2	1,2	1,2	2,5	1,2	2,5	1,2	2,5	6
Wiring diagram (Page 18/19)		3	4	3	4		4		4		3
Mains voltage (Rated voltage) ⁴⁾	[V]	305...500 +/-0 (400V)									
Phases		3									
Mains frequency	[Hz]	50 / 60 +/- 2									
Output voltage (U _N =Mains voltage)	[V]	3 x 0...U _N									
Output frequency	[Hz]	0...409,58 (0...819,16; 0...1638,32)									
Shielded motor line length	[m]	100									
Storage temperature	[°C]	-25...70 °C									
Operating temperature	[°C]	-10...45 °C									
Model / protective system		IP20									
Relative humidity (without condensation)	[%]	max. 95									
EMC tested in accordance with...		EN 61800-3									
Climatic category (EN 50178)		3K3									
Mains choke (s.page 29)		24		25			26		27		
Motor choke (s.page 35)		24		25			26		27		
HF-Filter assembly kit (s. page 31)		12	14	13	15	17	16	17	15	17	20
Sine filter (s. page 37)		4		5			6		7		
Sine filter plus (s. page 39)		4		-	5		-	-	-	-	-

The technical data is for 2/4 pole standard motors. With other pole numbers the inverter must be dimensioned onto the motor rated current. Contact KEB for special or medium frequency motors.



Site altitude max. 2000 m. With site altitudes over 1000 m a power reduction of 1% per 100m must be taken into consideration.

Summary of Technical Data 400V Class (>= Size 18)

Inverter Size		18		19		20	21	22	
Output nominal power	[kVA]	35		42		52	62	80	
Max. rated motor power	[kW]	22		30		37	45	55	
Output nominal current	[A]	50		60		75	90	115	
Max. short-time current ¹⁾	[A]	75		90		112,5	135	172,5	
OC-tripping current	[A]	90		108		135	162	207	
Nominal input current	[A]	55		66		83	100	127	
Housing size		H		R		R	R	R	
Rated operating frequency ²⁾	[kHz]	8	16	4	8	8	4/8	4	8
Max. operating frequency	[kHz]	16	16	16	16	16	16	4	8
Power loss at nominal operating	[W]	610	850	540	750	900	1100	1200	1500
Stall current at 8kHz	[A]	45	50	-	60	75	90	-	115
Stall current at 16kHz	[A]	20,3	40	-	27	33,7	40,5	-	-
Max. heat sink temperature T _{OH}	[°C]	90							
Max. permissible mains fuse (inert)	[A]	80		80		100	160	160	
Line cross section	[mm ²]	25		25		35	50	50	
Min. braking resistor ³⁾	[Ω]	13	9	13	9	9	9	8	
Typ. braking resistor ³⁾	[Ω]	20		15		12	10	8,6	
Max. braking current	[A]	63	88	63	88	88	88	88	
Overload curve (Page 40)		1							
Tightening torque for terminals	[Nm]	2,5	6	2,5	6				
Wiring diagram (Page 18/19)		4	3	4	3	3	3	3	
Mains voltage (Rated voltage) ⁴⁾	[V]	305...500 +/- 0 (400V)							
Phases		3							
Mains frequency	[Hz]	50 / 60 +/- 2							
Output voltage (U _N =Mains voltage)	[V]	3 x 0...U _N							
Output frequency	[Hz]	0...409,58 (0...819,16; 0...1638,32)							
Shielded motor line length	[m]	100		100		50	50	50	
Storage temperature	[°C]	-25...70 °C							
Operating temperature	[°C]	-10...45 °C							
Model / protective system		IP20							
Relative humidity (without condensation)	[%]	max. 95							
EMC tested in accordance with...		EN 61800-3							
Climatic category (EN 50178)		3K3							
Mains choke (s.page 29)		28		29		30	31	32	
Motor choke (s.page 35)		28		29		30	31	32	
HF-Filter assembly kit (s. page 31)		17	20	17	20	20	22	22	
Sine filter (s. page 37)		8		9		10	11	12	
Sine filter plus (s. page 39)		-	-	-	-	-	-	-	

- 1) For F4F-Types 5% must be substrated as control reserve
- 2) F4-F units need a power circuit with rated operating frequency of min. 8kHz.
- 3) This data is only valid for units with internal brake transistor (see "unit identification").
- 4) At mains voltage ≥460V multiply the nominal current with factor 0,86.

Inverter Size		23	24	25	26	27		
Output nominal power	[kVA]	104	125	145	173	208		
Max. rated motor power	[kW]	75	90	110	132	160		
Output nominal current	[A]	150	180	210	250	300		
Max. short-time current ¹⁾	[A]	225	270	262,5	312,5	375		
OC-tripping current	[A]	270	324	315	375	450		
Nominal input current	[A]	165	198	231	275	330		
Housing size		R	U	U	U	U		
Rated operating frequency ²⁾	[kHz]	2	8	4	8	4	4	2
Max. operating frequency	[kHz]	2	16	4	8	4	4	2
Power loss at nominal operating	[W]	1300	1900	2000	2400	2300	2800	3100
Stall current at 8kHz	[A]	-	150	-	180	-	-	-
Stall current at 16kHz	[A]	-	-	-	-	-	-	-
Max. heat sink temperature T _{OH}	[°C]	90						
Max. permissible mains fuse (inert)	[A]	200		315		315	400	450
Line cross section	[mm ²]	95		95		95	120	150
Min. braking resistor ³⁾	[Ω]	6	5	4		2,7	2,7	2,7
Typ. braking resistor ³⁾	[Ω]	6,7		5		4,3	3,8	3,3
Max. braking current	[A]	133	160	200		200	200	200
Overload curve (Page 40)		1			2			
Tightening torque for terminals	[Nm]	15			25			
Wiring diagram (Page 18/19)		3	3	3		3	3	3
Mains voltage (Rated voltage) ⁴⁾	[V]	305...500 +/-0 (400V)						
Phases		3						
Mains frequency	[Hz]	50 / 60 +/- 2						
Output voltage (U _N =Mains voltage)	[V]	3 x 0...U _N						
Output frequency	[Hz]	0...409,58 (0...819,16; 0...1638,32)						
Shielded motor line length	[m]	50						
Storage temperature	[°C]	-25...70 °C						
Operating temperature	[°C]	-10...45 °C						
Model / protective system		IP20						
Relative humidity (without condensation)	[%]	max. 95						
EMC tested in accordance with...		EN 61800-3						
Climatic category (EN 50178)		3K3						
Mains choke (s. page 29)		33		34		35	36	37
Motor choke (s. page 35)		33		34		35	36	37
HF-Filter assembly kit (s. page 31)		23		24		24	26	26
Sine filter (s. page 37)		-	33	34		35	36	37
Sine filter plus (s. page 39)		-	-	-		-	-	-



An input choke is necessary from size 23!

The technical data is for 2/4 pole standard motors. With other pole numbers the inverter must be dimensioned onto the motor rated current. Contact KEB for special or medium frequency motors.



Site altitude max. 2000 m. With site altitudes over 1000 m a power reduction of 1% per 100m must be taken into consideration.

2.3 Dimensions and Weight

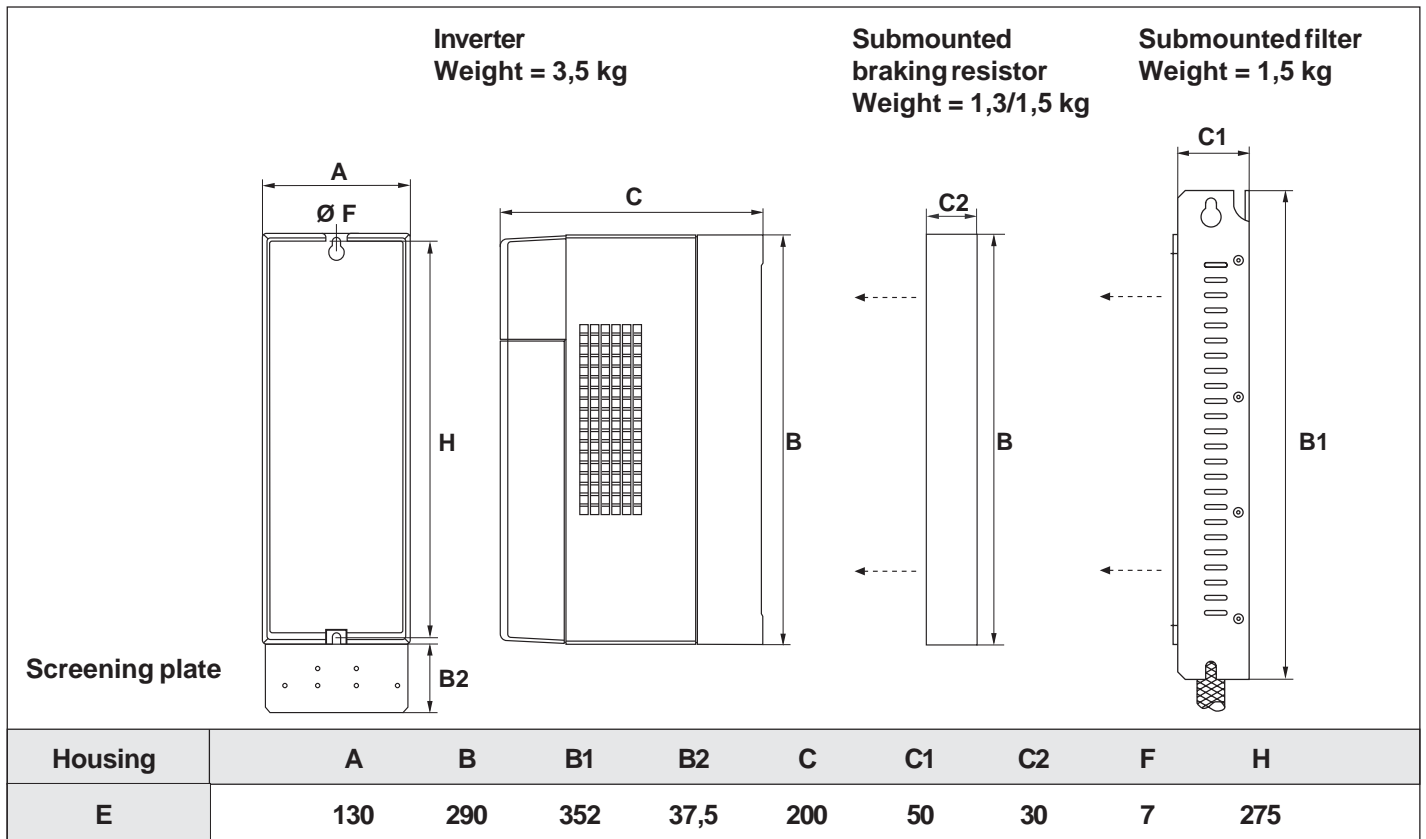
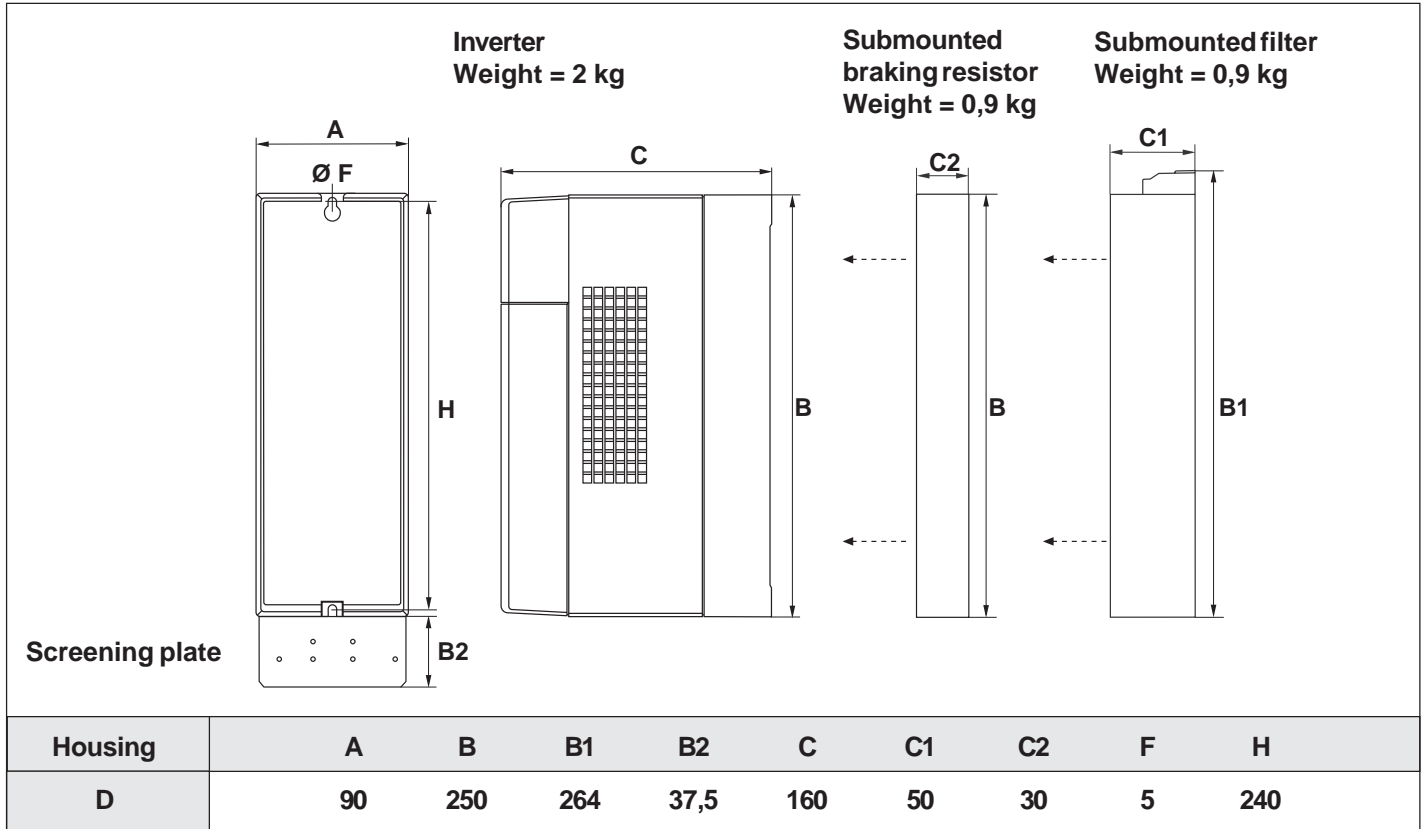

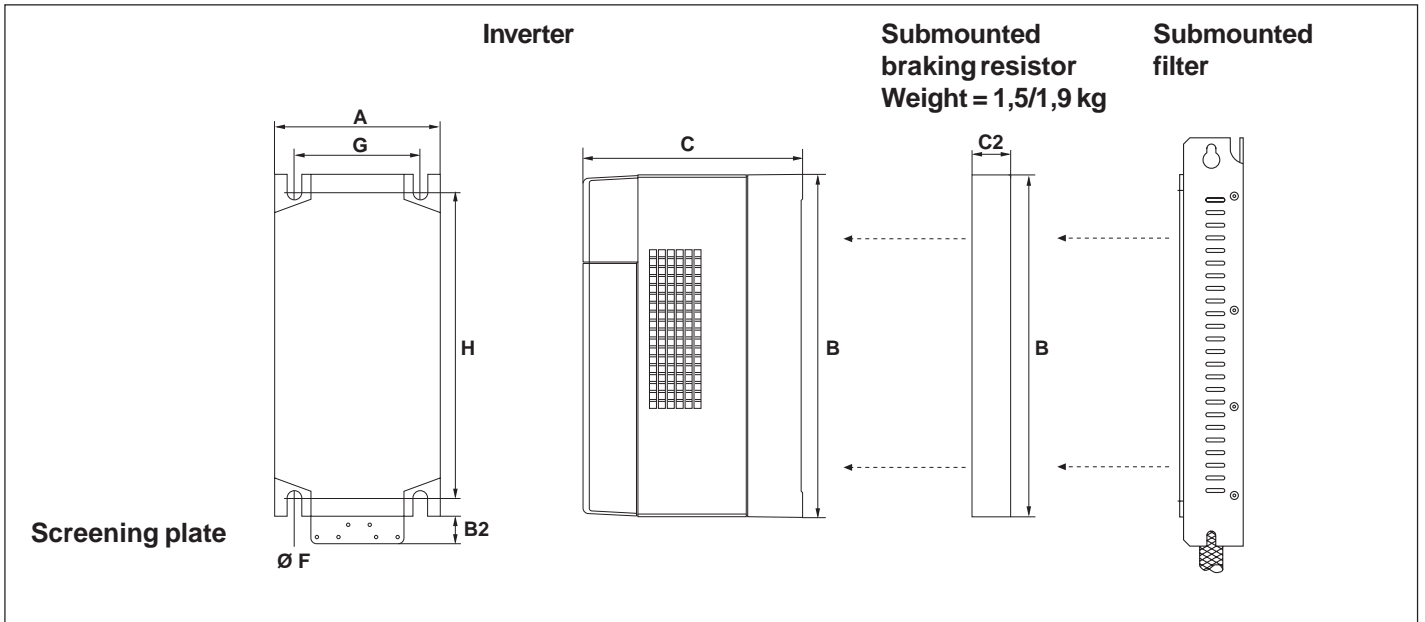





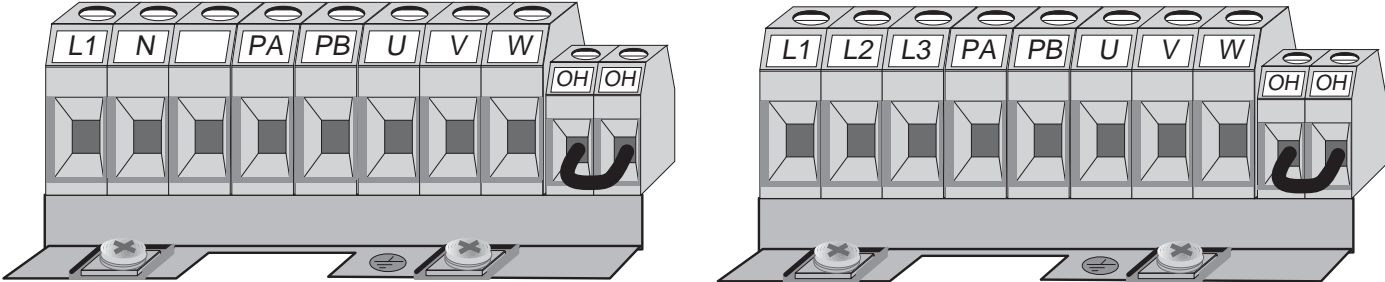

Housing	A	B	B2	C	C2	F	G	H	Weight [kg]
G	170	340	32	255	30	7	150	330	10
H	297	340	51	255	-	7	250	330	14
R *	340	520	68	355	-	11	300	495	25-29
U	340	800	-	355	-	11	300	775	75

Dimensions and wights of the HF-filter: see page 31 / pic. 2

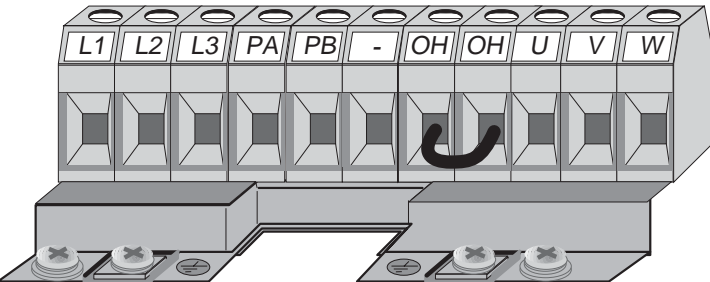
*) The R-Housing installation filter have no influence to the dimensions of the housing. (Weight = 7 kg)

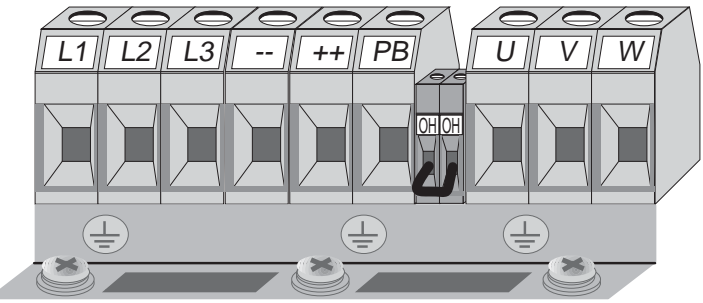
2.4 Summary of the Power Circuit Terminals

Housing size D  Note input voltage, since 230V and 400V class (3 phase) is possible.	
1 phase	3 phase
	
L1, N 1 phase mains connection L1, L2, L3 3 phase mains connection PA, PB Connection for braking resistor	U, V, W Motor connection OH, OH Connection for temperature sensor  Connection for screening/earthing
Housing size E  Note input voltage, since 230V and 400V class (3 phase) is possible.	
	
	L1, L2, L3 3 phase mains connection PA, PB Connection for braking resistor PA, - Connection for braking module and feedback unit OH, OH Connection for temperature sensor U, V, W Motor connection  Connection for screening/earthing
Housing size G  Note input voltage, since 230V and 400V class (3 phase) is possible.	
	
	L1, L2, L3 3 phase mains connection ++, PB Connection for braking resistor ++, -- Connection for braking module, feedback and supply unit DC input 250...370 VDC (230 V-class) 420...720 VDC (400 V-class) OH, OH Connection for temperature sensor U, V, W Motor connection  Connection for screening/earthing

Housing size H



Note input voltage, since 230V and 400V class (3 phase) is possible.

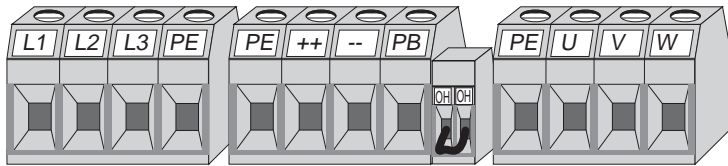

- L1, L2, L3** 3 phase mains connection
- ++, PB** Connection for braking resistor
- ++, --** **Connection for braking module, feedback and supply unit DC input**
250...370 VDC (230 V-class)
420...720 VDC (400 V-class)
- OH, OH** Connection for temperature sensor
- U, V, W** Motor connection
- PE** Connection for screening/earthing

Housing size R and U



Note input voltage, since 230V and 400V class (3 phase) is possible.

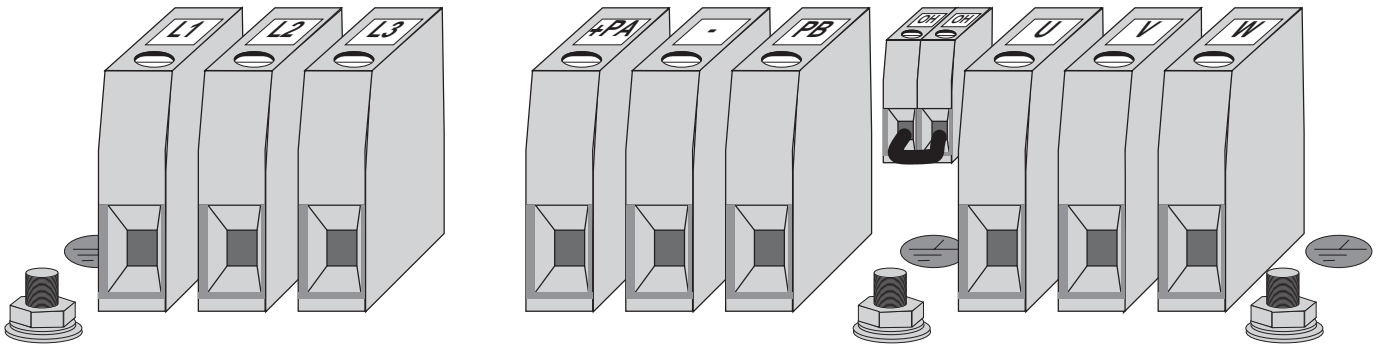

- L1, L2, L3** 3 phase mains connection
- +PA, PB** Connection for braking resistor
- +PA, -** Connection for braking module and feedback unit

- OH, OH** Connection for temperature sensor
- U, V, W** Motor connection
- Connection for screening/earthing

Connection of the Power Circuit

2.6 Connection of the Power Circuit

Assignment see technical data "Wiring diagram" Page 9-13



If the mains and motor connection are exchanged, this leads to immediate destruction of the unit.



Pay attention to the supply voltage and the correct polarity of the motor!

Wiring diagram 1

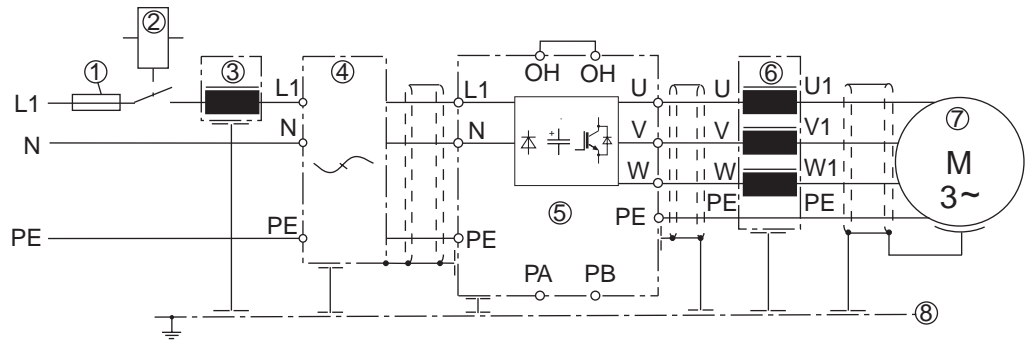

Wiring diagram 2

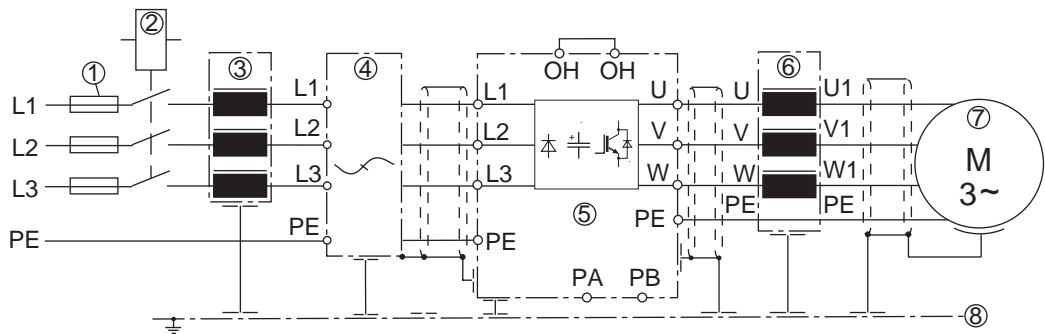

Wiring diagram 3

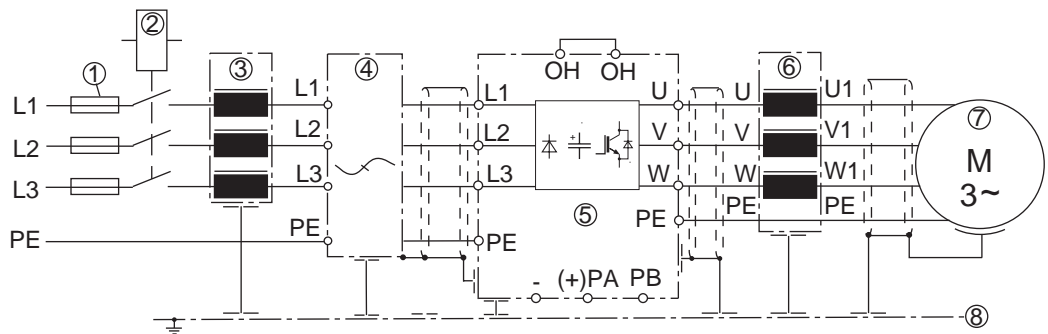

Wiring diagram 4

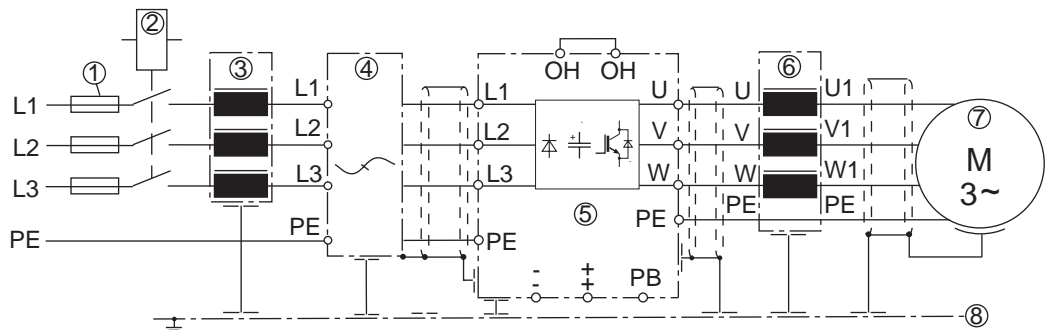

- | | |
|-----------------------------------|---|
| ① Mains fuse | ⑤ KEB COMBIVERT |
| ② Main contactor | ⑥ Motor choke or output filter (not for F4-F) |
| ③ Input choke | ⑦ Motor |
| ④ Interference suppression filter | ⑧ Mounting plate |

External temperature monitoring (for all units)

Don't install OH-wiring (also shielding) with control cable!
Only permissible with double-shielding into the motor cable!

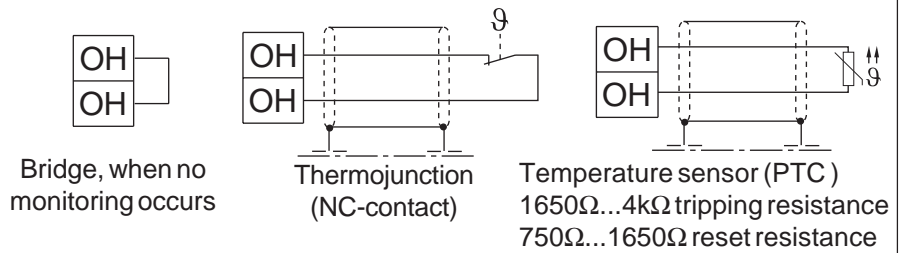

Connection of braking resistor (only with internal brake transistor see page 5)

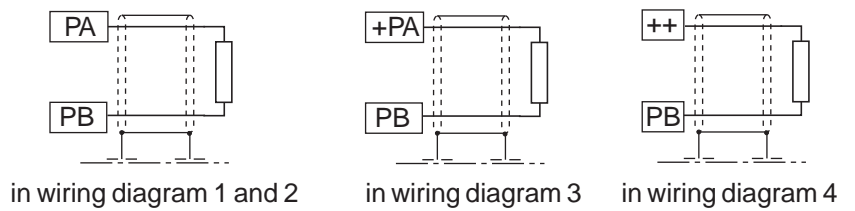

Connection of a braking module

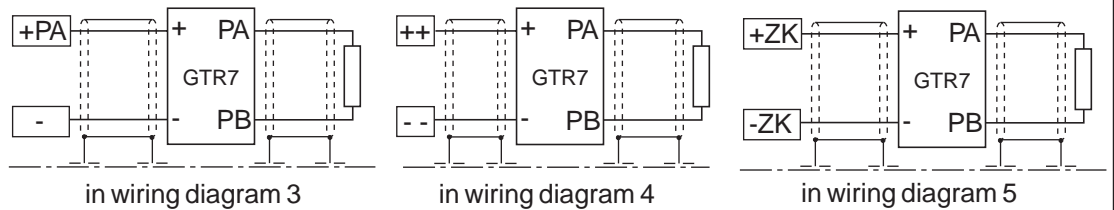

DC mains power input (only when terminals are ++ and --)

250...370 VDC (230 V-class)
420...720V DC (400 V-class)

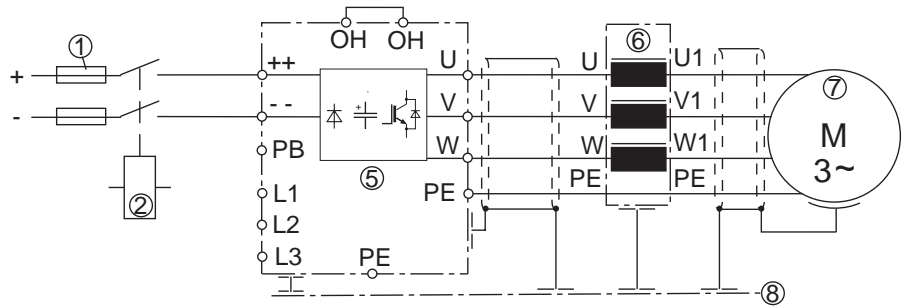

- | | |
|-----------------------------------|---|
| ① Mains fuse | ⑤ KEB COMBIVERT |
| ② Main contactor | ⑥ Motor choke or output filter (not for F4-F) |
| ③ Input choke | ⑦ Motor |
| ④ Interference suppression filter | ⑧ Mounting plate |

3. Accessories

3.1 Braking resistor

Installation Tip



GB

Selection of the braking resistor

KEB COMBIVERT is equipped with an external braking resistor or an external braking option and is suited for restricted 4 quadrant operation. The braking energy that is refeed into the intermediate circuit during regenerative operation is dissipated by means of the braking transistor, the control and the braking resistor.

The braking resistor heats up during braking. If it is installed inside a control cabinet sufficient cooling of the control cabinet interior must be provided and sufficient distance to the KEB COMBIVERT must be kept.

Different braking resistors are available for KEB COMBIVERT. They are selected according to their application requirements. The respective formulas and restrictions (validity range) are listed on the next page.

1. Preset desired braking time.
2. Calculate braking time without braking resistor (t_{Bmin}).
3. If the desired braking time is smaller than the calculated braking time, it will be necessary to use a braking resistor. ($t_b < t_{Bmin}$)
4. Calculate braking torque (M_B) and take the load torque into account.
5. Calculate peak braking power (P_B). This must always be calculated for the "worst case" (n_{max} at standstill).
6. Selection of the braking resistors:
 - a) $P_R \geq P_B$
 - b) P_N is to be selected in accordance with the cyclic duration factor. The braking resistors may only be used for the units listed. The max. ON period of the braking resistor may not be exceeded. Longer ON periods require special-designed braking resistors. Take into account the continuous output of the braking transistor.
7. Check whether the desired braking time is attained with the braking resistor (t_{Bmin}).

Restriction: Considering the capacity of the braking resistor and the braking capacity of the motor, the braking torque may not exceed the rated torque of the motor by more than 1.5 times (see formula).

To utilize the maximum possible braking torque the frequency inverter must be laid out for the increased current.

Braking time

The braking time is adjusted on the frequency inverter. If the selected time is too short the KEB COMBIVERT/COMBIDRIVE automatically switches off and displays the error message **OP** or **OC**. The following formulas allow an approximate determination of the braking time.

Formulas

1. Braking time without braking resistor

$$t_{Bmin} = \frac{(J_M + J_L) \cdot (n_1 - n_2)}{9,55 \cdot (K \cdot M_N + M_L)}$$

Validity range: $n_1 > n_N$

(field weakening range)

2. Braking torque (required)

$$M_B = \frac{(J_M + J_L) \cdot (n_1 - n_2)}{9,55 \cdot t_B} M_L$$

Condition: $M_B \leq 1,5 \cdot M_N$

$f \leq 70$ Hz

3. Peak braking power

$$P_B = \frac{M_B \cdot n_1}{9,55}$$

Condition: $P_B \leq P_R$

4. Braking time with braking resistor

$$t_{Bmin}^* = \frac{(J_M + J_L) \cdot (n_1 - n_2)}{9,55 \cdot (K \cdot M_N + M_L + \frac{P_R \cdot 9,55}{(n_1 - n_2)})}$$

Validity range: $n_1 > n_N$

Condition: $\frac{P_R \cdot 9,55}{(n_1 - n_2)} \leq M_N \cdot (1,5 - K)$

$f \leq 70$ Hz

$P_B \leq P_R$

K = 0,25 for motors	to 1,5 kW
0,20 for motors	2,2 to 4 kW
0,15 for motors	5,5 to 11 kW
0,08 for motors	15 to 45 kW
0,05 for motors	> 45 kW

J_M	=	Moment of inertia of the motor	[kgm ²]
J_L	=	Moment of inertia of the load	[kgm ²]
n_1	=	Motor speed before deceleration	[min ⁻¹]
n_2	=	Motor speed after deceleration (Stand still = 0 rpm)	[min ⁻¹]
n_N	=	Motor rated speed	[min ⁻¹]
M_N	=	Motor rated torque	[Nm]
M_B	=	Braking torque (required)	[Nm]
M_L	=	Load torque	[Nm]
t_B	=	Braking time (required)	[s]
t_{Bmin}	=	Minimum braking time	[s]
t_z	=	Cycle time	[s]
P_B	=	Peak braking power	[W]
P_R	=	Peak power of the braking resistor	[W]

On period c.d.f.

ON period c.d.f for cycle time $t_z \leq 120$ s

$$c.d.f = \frac{t_B}{t_z} \cdot 100 \%$$

ON period c.d.f for cycle time $t_z > 120$ s

$$c.d.f = \frac{t_B}{120 \text{ s}} \cdot 100 \%$$

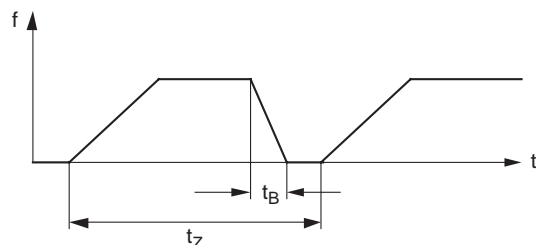

3.1.1 Side mounting braking resistor

Technical data braking resistor

Part number	R _B [OHM]	P _{Rated} [kW]	COMBIVERT	Nominal power ¹⁾ [W]		
				6 %	25 %	40 %
230 V - Class						
07.BR.100-1180	180	44	05, 07	800	300	180
09.BR.100-1100	100	82	07, 09	1500	500	300
10.BR.100-1683	68	120	07, 09, 10, 13(E)	2200	800	500
12.BR.100-1333	33	250	10, 13(G)	4400	1300	750
13.BR.100-1273	27	300	13(G), 14	5400	1500	900
14.BR.100-1203	20	450	13(G), 14	7300	1800	1100
15.BR.110-1133	13	630	14, 15	10000	3200	1800
16.BR.110-1103	10	850	15, 16	14000	3600	2200
17.BR.110-1073	7	1100	15, 16	21000	5400	3100
18.BR.xxx-xxxx		on request				
19.BR.xxx-xxxx		on request				
20.BR.xxx-xxxx		on request				
21.BR.xxx-xxxx		on request				
400 V - Class						
07.BR.100-6620	620	56	05, 07	900	300	180
09.BR.100-6390	390	90	07, 09	1500	500	300
10.BR.100-6270	270	130	07, 09, 10	2100	800	500
12.BR.100-6150	150	230	12	3700	1300	750
13.BR.100-6110	110	350	12, 13	5000	1500	900
14.BR.100-6853	85	410	12, 13, 14	6500	1800	1100
15.BR.110-6563	56	620	12(E), 13(E,G), 14, 15	10000	3200	1800
16.BR.110-6423	42	820	13(G), 14(G), 15, 16	13500	3600	2200
17.BR.110-6303	30	1200	15(H), 16, 17	18500	5400	3100
18.BR.226-6203	20	1700	17(R), 18, 19	27500	7500	4500
19.BR.226-6153	15	2300	17(R), 18, 19, 20	37000	10000	6000
20.BR.226-6123	12	2900	18(R), 19(R), 20, 21	46000	12500	7500
21.BR.226-6103	10	3000	18(R), 19(R), 20, 21, 22	55000	15000	9000
22.BR.226-6866	8,6	4000	21(L), 22(L), 23	64000	17500	10000
23.BR.226-6676	6,7	5200	22(L), 23, 24(U)	82000	22000	12500
24.BR.226-6506	5	6900	23(U), 24(U), 25(U)	110000	30000	18000
25.BR.226-6436	4,3	8100	24(U), 25(U), 26(U), 27(U)	130000	35000	20000
26.BR.226-6386	3,8	9200	25, 26, 27(U)	145000	40000	22500
27.BR.226-6336	3,3	10000	25, 26, 27(U)	170000	45000	25000
28.BR.226-6226	2,2	15000	28(W), 29(W), 30(W)	250000	67000	37000
29.BR.226-6176	1,7	20000	28(W), 29(W), 30(W)	325000	90000	50000
30.BR.226-6136	1,3	26000	28(W), 29(W), 30(W)	425000	112000	62000

1) Permissible load of the resistor in dependence on the cyclic duration factor related to 120 s cycle time. The calculated peak braking time must be ≤ the load of the resistor. If the value is not achieved, please contact KEB.

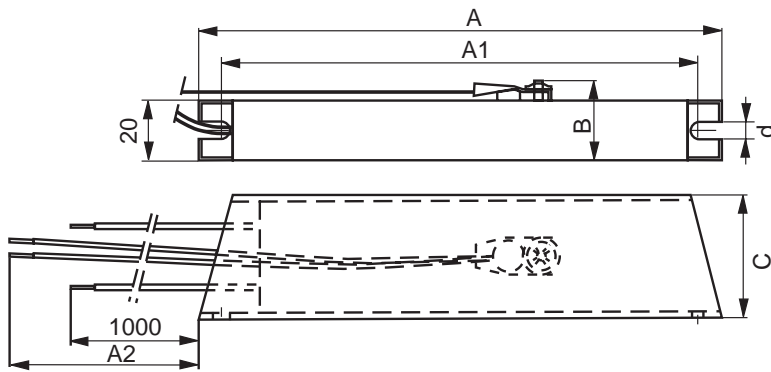

Part number	A	A1	A2	B	C	d
07.BR.100-xxxx	160	145	1120	26	40	6
09.BR.100-xxxx	240	222	1060	26	40	6
10.BR.100-xxxx	300	285	1030	26	40	6
11.BR.100-xxxx	240	225	1085	28	80	5,5
12.BR.100-xxxx	300	285	1055	28	80	5,5
13.BR.100-xxxx	400	400	1005	28	80	5,5
14.BR.100-xxxx	400	400	1005	28	80	5,5

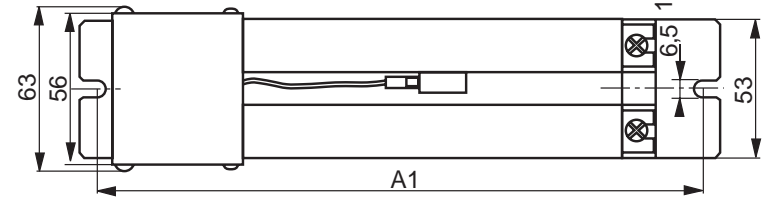
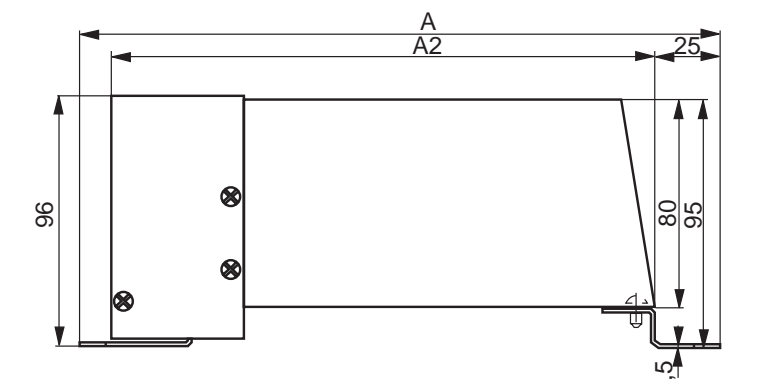

Part number	A	A1	A2
15.BR.110-xxxx	370	355	300
16.BR.110-xxxx	470	455	400

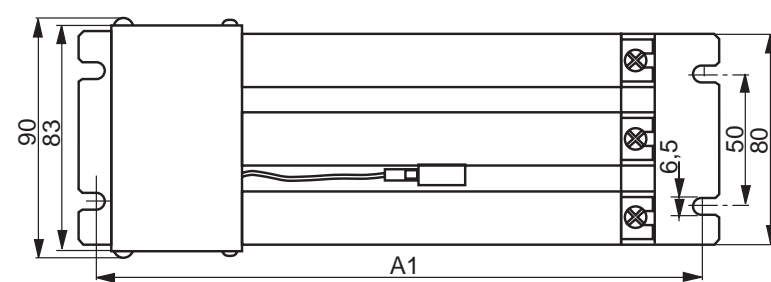

17.BR.110-xxxx	470	455	400
----------------	-----	-----	-----

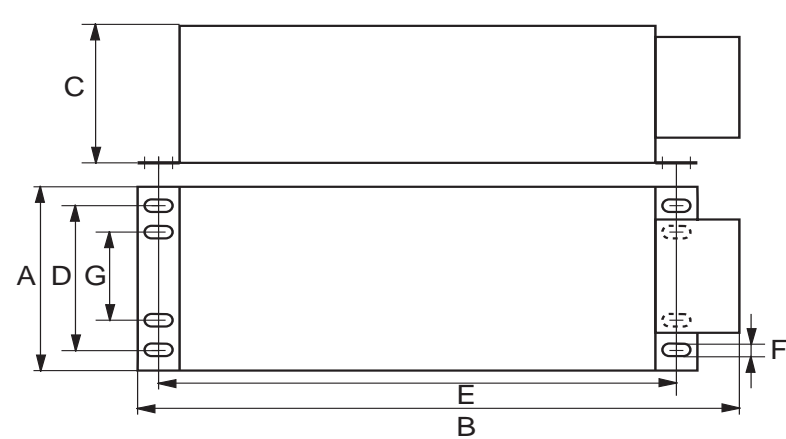

Part number	A	B
18.BR.226-6203	611	116
19.BR.226-6153	611	116
20.BR.226-6123	631	221
21.BR.226-6103	631	221
22.BR.226-6866	631	271
23.BR.226-6676	631	271
24.BR.226-6506	= 2 x 21.BR.226-6103	
25.BR.226-6436	= 2 x 22.BR.226-6866	
26.BR.226-6386	= 1 x 22.BR.226-6866 + 1 x 23.BR.226-6676	
27.BR.226-6336	= 2 x 23.BR.226-6676	
28.BR.226-6226	= 3 x 23.BR.226-6676	
29.BR.226-6176	= 4 x 23.BR.226-6676	
30.BR.226-6136	= 5 x 23.BR.226-6676	

3.1.2 Parallel connection of braking resistors

Terminal strip braking resistor

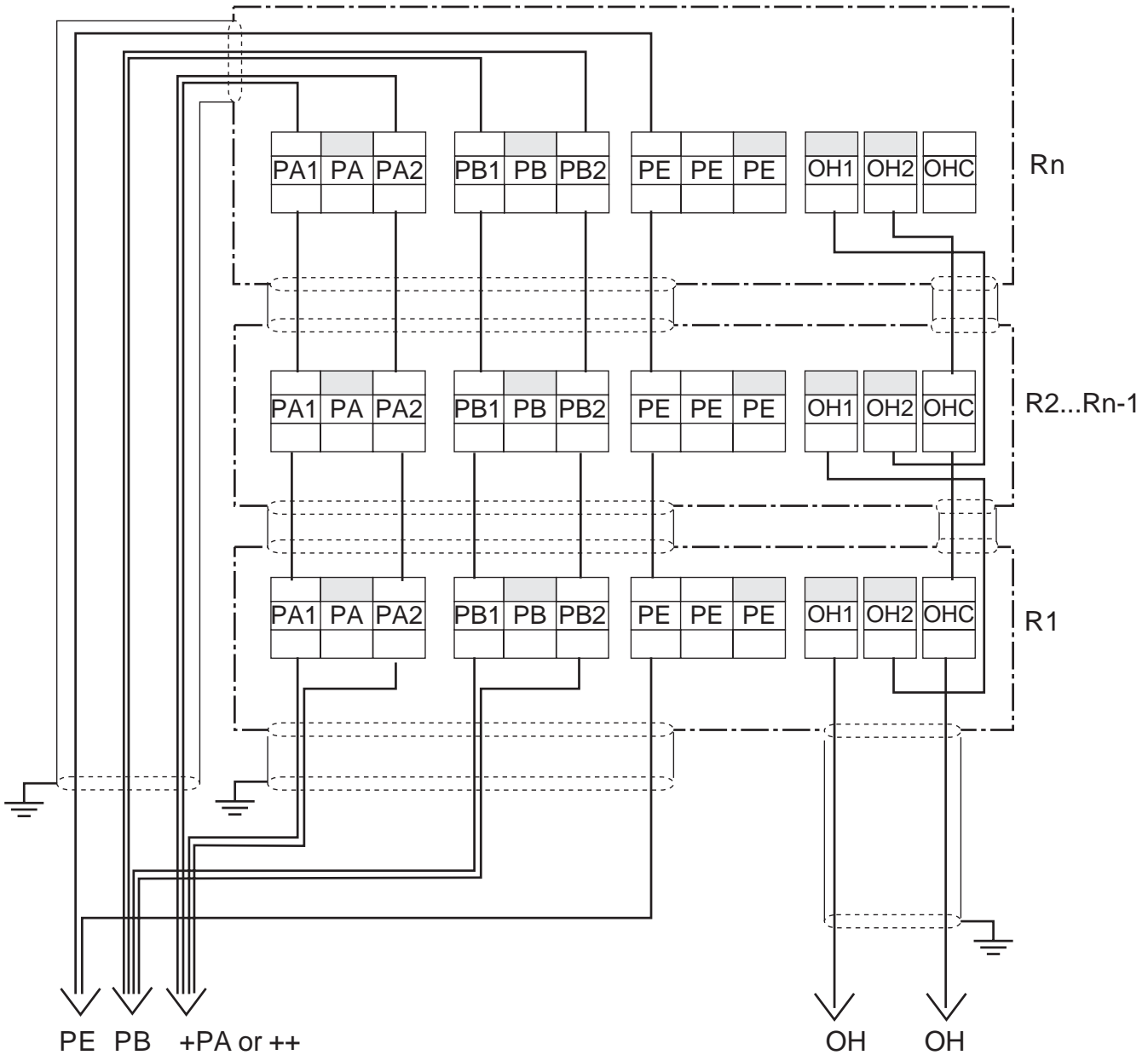
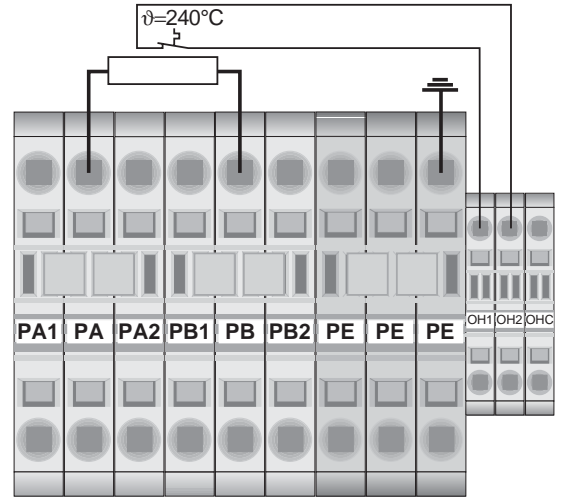

3.1.3 Submounting braking resistor

The submounting braking resistors are planned for a small volume installation directly under the frequency inverter. Mostly they are suitable for short braking cycles and clock system. The assemblies are made of:

- Braking resistor
- Temperature switch
- Submounted box
- Installation material

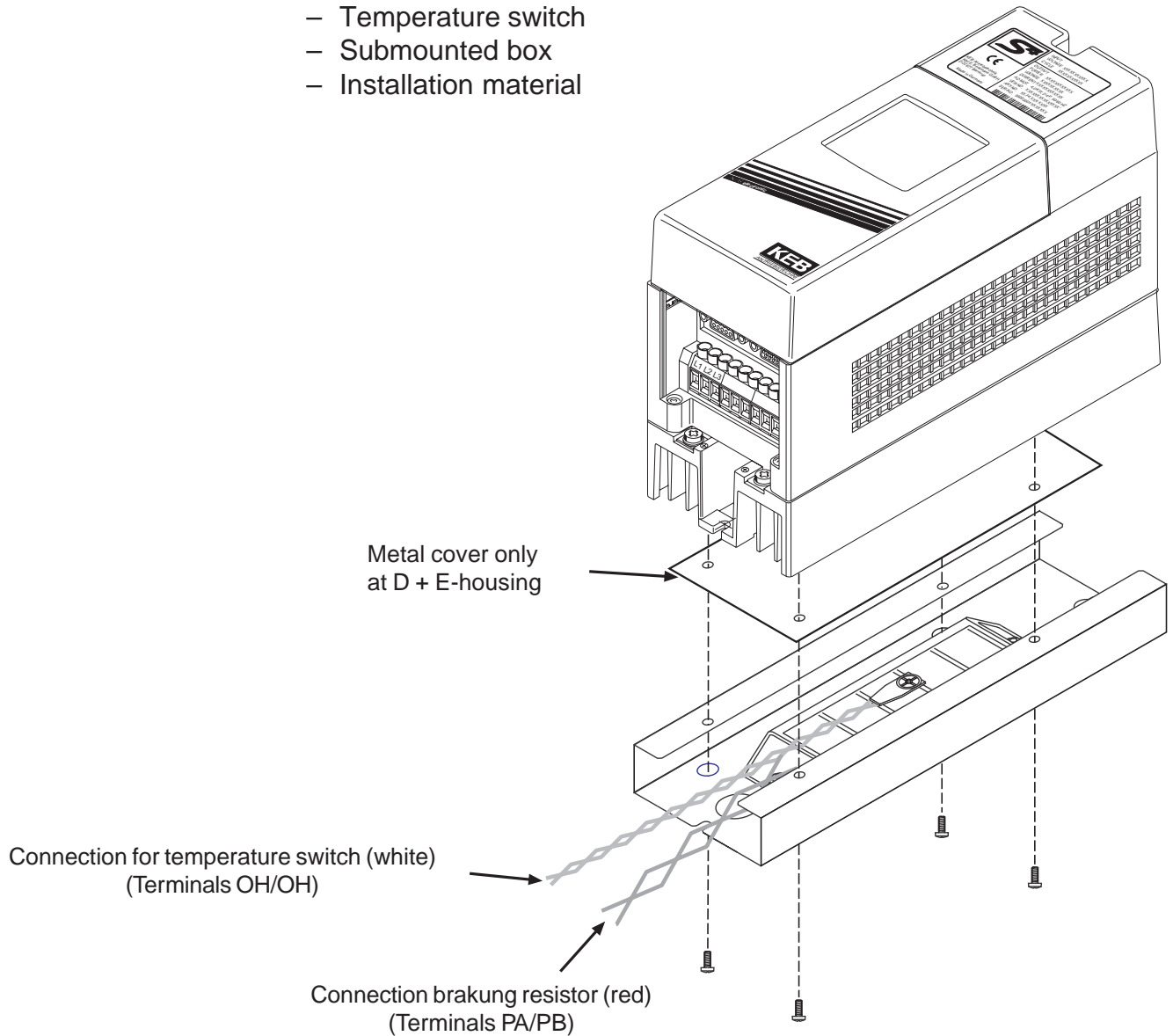

GB

Size		10	12	12/13/14	15	13/14/15	16
Housing		D	D	E	E	G	G
Braking resistor	[Ω]	160	82	60	30	50	25
Permanent load	[W]	35	35	60	2 x 60	80	2 x 80
Non-recurring load (max. 3s)	[W]	3600	7800	9600	19000	11500	23000
Permissible load at 5% c.d.f.	[W]	700	700	1200	2400	1600	3200
Permissible load at 10% c.d.f.	[W]	350	350	600	1200	800	1600
Permissible load at 20% c.d.f.	[W]	175	175	300	600	400	800
Permissible load at 40% c.d.f.	[W]	90	90	150	300	200	400
Weight	[kg]	0,89	0,9	1,3	1,5	1,5	1,9
Partnumber of the kit		10.F4.D50-4200	12.F4.D50-4200	14.F4.E50-4200	15.F4.E50-4200	15.F4.G50-4200	16.F4.G50-4200

GB

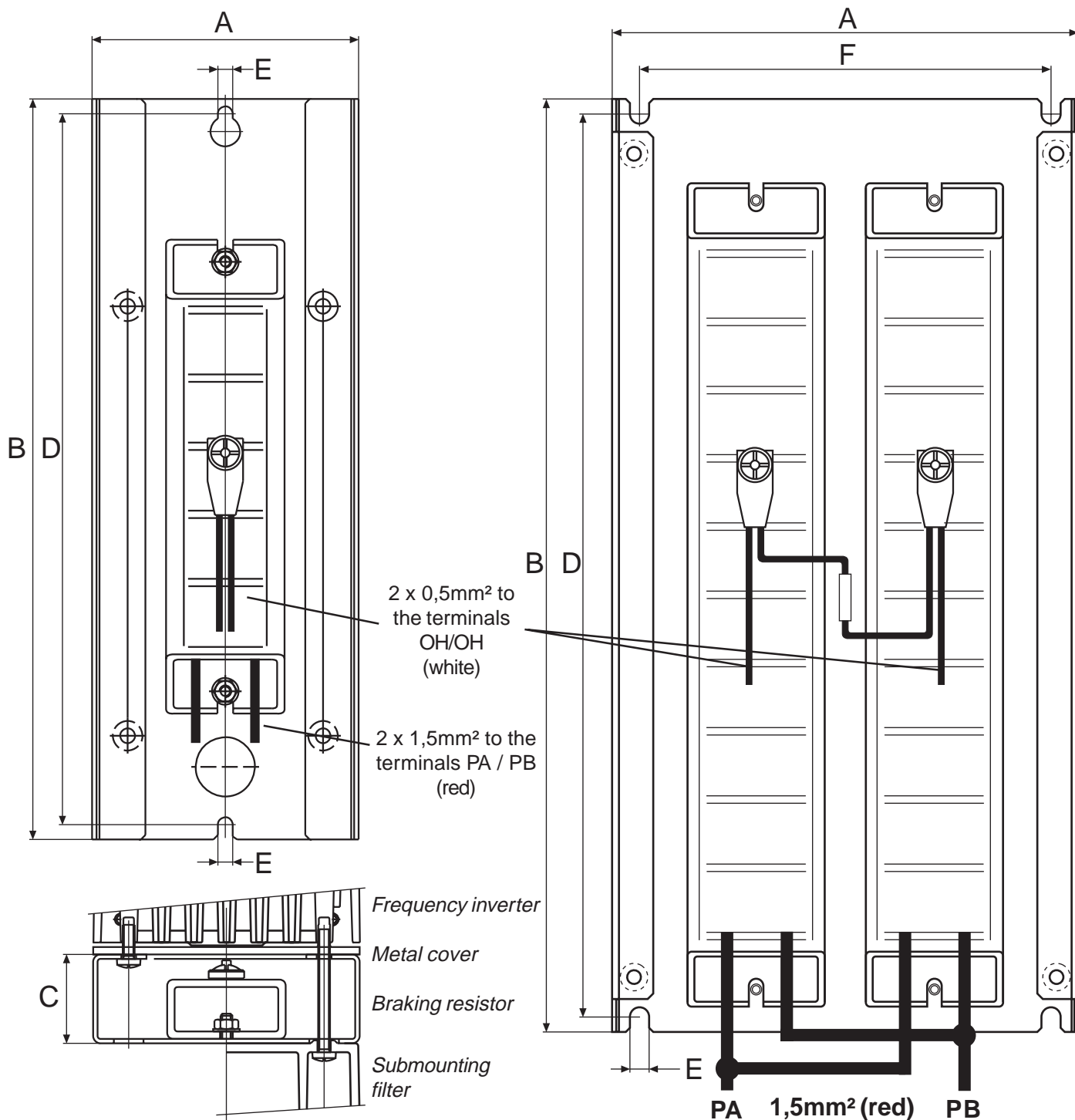

Dimensions
Submounting braking resistors

Housing	D	E	G
A [mm]	90	130	170
B [mm]	250	290	340
C [mm]	30	30	25
D [mm]	240	275	329
E [mm]	5	7	7
F [mm]	-	-	150

Attention Fire Risk!



In order to detect the overheating of a braking resistor it is absolutely necessary to monitor the temperature switch. The overheating can have following causes:

- ramps too short or the operation-time too long
- incorrect dimensioning of the braking resistor
- input voltage too high
- defect of braking transistor in the inverter or the braking module

The disconnection of the mains voltage offers the only protection in the case of a defective braking transistor (see diagram).

Braking resistors can develop a very high surface temperature, therefore install as safe-to-touch as possible!

Connection of the braking resistor

- +/PA, PB Terminals for the braking resistor
- during release of the temperature monitoring the input voltage is switched off

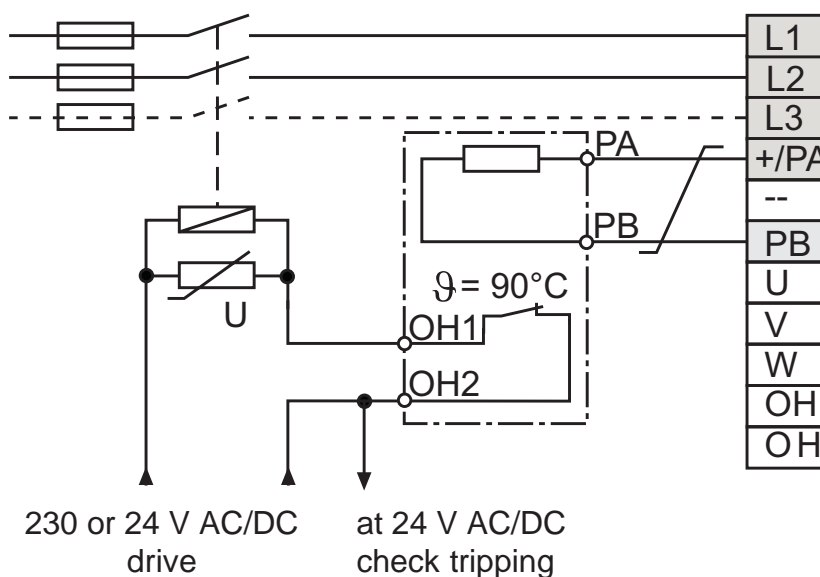

A simplified protection is achieved, if the links of the temperature sensor are integrated into the temperature detection in accordance with following drawing. This measure does not protect with a defect of the braking transistor however against the developing extreme overload with acute danger of fire.

Connection of the temperatur detection

- Terminals OH
- Do not lay connecting cable together with control cables!

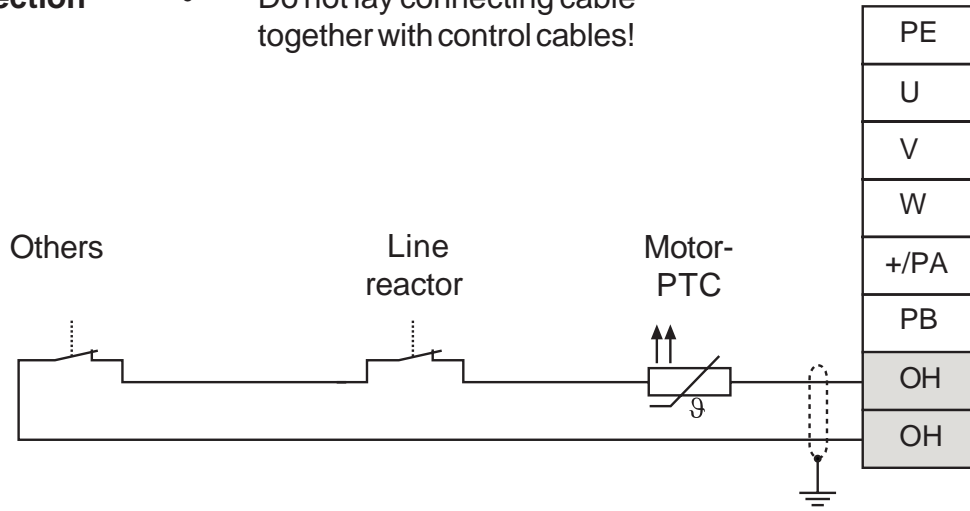

GB

3.2 Input filter

3.2.1 Input choke

The KEB input choke is dimensioned according to the regulations VDE 0160 with short circuit voltage of UK = 4%. By reducing the harmonics the power factor of the inverter improves from 0.5...0.6 to approximately 0.8...0.9.

With a frequency range from 10 kHz to approximately 300 kHz the values of the conducted HF-interferences are reduced up to 30 db.

Additionally the noise immunity of the system is improved and the DC-link capacitors lifetime increases.

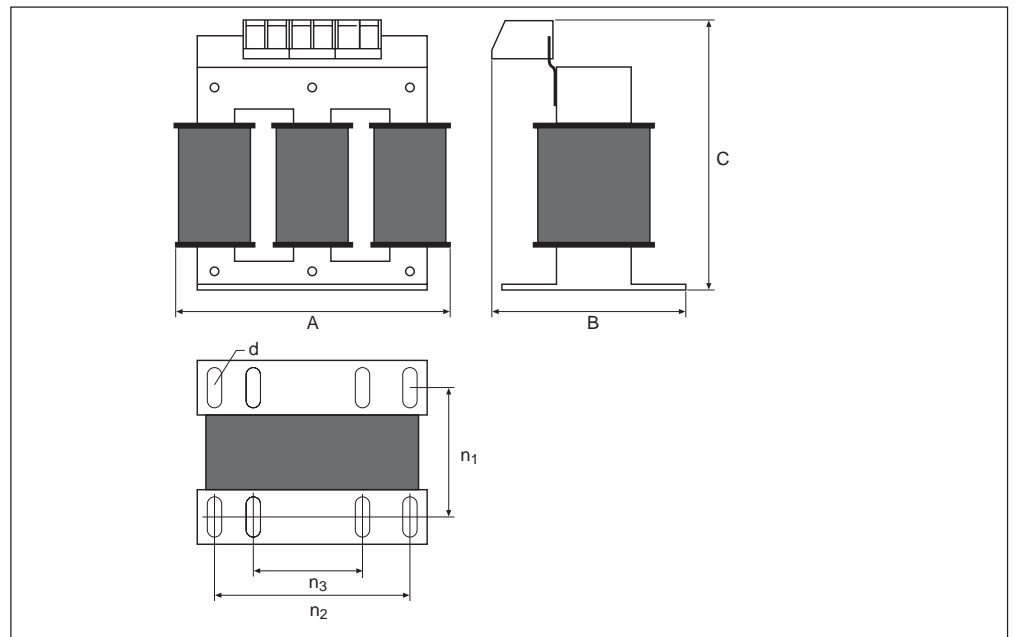

GB

230V-Class 4% terminal short circuit voltage

Number	For COMBIVERT	Phases	I _{rated} [A]	P _{loss} [W]	Part number	Dimensions						Terminal [mm ²]	Weight [kg]	
						A	B	C	n ₁	n ₂	n ₃			d
1	05	1	6	9	05.DR.F08-4951	60	60	80	37	45	-	3,6 x 7	4	0,5
2	05	3	4	14	05.DR.A08-4251	129	62	115	41	112	-	4,8 x 9	4	0,8
3	07	1	10	9	07.DR.F08-2951	84	86	100	48	64	-	4,8 x 9	4	1,4
4	07	3	6	21	07.DR.A08-2851	129	62	115	41	112	-	4,8 x 9	4	1,2
5	09	1	16	15	09.DR.F08-1851	84	86	100	48	64	-	4,8 x 9	4	1,5
6	09	3	8	21	09.DR.A08-2151	129	62	115	41	112	-	4,8 x 9	4	1,2
7	10	1	20	15	10.DR.F08-1551	84	86	100	48	64	-	4,8 x 9	4	1,5
8	10	3	12	30	10.DR.A08-1551	129	72	115	50	112	-	4,8 x 9	4	1,8
9	12	1	25	18	12.DR.F08-1151	96	100	115	62	84	-	5 x 11	4	2,5
10	12	3	20	30	12.DR.A08-8541	148	100	160	60	136	60	4,8 x 8	10	3
11	13	3	30	45	13.DR.A08-5641	148	100	160	60	136	60	4,8 x 8	10	3,7
12	14	3	40	50	14.DR.A08-4241	178	130	195	55	166	113	4,8 x 8	16	5
13	15	3	60	63	15.DR.A08-2841	178	145	235	70	166	113	4,8 x 8	16	6,4
14	16	3	70	74	16.DR.A08-2241	219	148	240	71	201	136	7 x 12	35	7,6
15	17	3	85	92	17.DR.A08-1841	219	170	255	81	201	136	7 x 12	95	10,5
16	18	3	100	90	18.DR.A08-1541	219	190	255	91	201	136	7 x 12	95	12
17	19	3	130	115	19.DR.A08-1241	267	195	300	81	249	176	7 x 12	95	15,3
18	20	3	160	155	20.DR.A08-1041	267	220	300	105	249	176	7 x 12	95	18
19	21	3	200	158	21.DR.A08-8031	267	215	310	102	249	176	7 x 12	95	29
20	22	3	230	170	22.DR.A08-6031	267	235	335	116	249	176	7 x 12	150	31

400V-Class 4% terminal short circuit voltage														
Number	For COMBIVERT	Phases	I _{rated} [A]	P _{loss} [W]	Part number	Dimensions							Terminal [mm ²]	Weight [kg]
						A	B	C	n ₁	n ₂	n ₃	d		
19	05	3	4	22	05.DR.B08-7351	129	72	115	50	112	-	4,8 x 9	2,5	1,35
20	07, 09		6	22	07.DR.B08-4951	129	72	115	50	112	-	4,8 x 9	2,5	1,6
21	10		8	33	10.DR.B08-3751	148	80	140	60	136	90	4,8 x 8	2,5	2,5
22	12		10	33	12.DR.B08-2851	148	80	140	60	136	60	4,8 x 8	2,5	2,5
23	13		16	53	13.DR.B08-1851	178	95	165	55	166	113	4,8 x 8	2,5	5,2
24	14		20	54	14.DR.B08-1451	178	95	165	55	166	113	4,8 x 8	4	5,4
25	15		30	76	15.DR.B08-9841	178	110	175	70	166	113	4,8 x 8	10	5,8
26	16		40	76	16.DR.B08-7341	178	110	175	70	166	113	7 x 12	10	6,8
27	17		50	97	17.DR.B08-5941	219	100	200	71	201	136	7 x 12	10	8
28	18		60	100	18.DR.B18-4941	219	110	200	81	201	136	7 x 12	10	9,8
29	19		75	110	19.DR.B18-3941	219	160	235	91	201	136	7 x 12	35	13,1
30	20		90	151	20.DR.B18-3341	267	186	285	81	249	176	7 x 12	35	15,6
31	21		115	181	21.DR.B18-2841	267	210	275	105	249	176	7 x 12	35	21,9
32	22		150	205	22.DR.B18-2241	316	200	330	99	292	200	9 x 13	95	24,7
33	23		180	145	23.DR.B18-1741	267	207	310	94	249	176	7 x 12	95	24,1
34	24		200	168	24.DR.B18-1541	267	215	310	102	249	176	7 x 12	95	28,3
35	25		230	230	25.DR.B18-1341	267	230	335	111	249	176	9 x 13	150	30
36	26		270	290	26.DR.B28-1141	352	230	400	105	328	224	10 x 16	240	37,3
37	27		300	308	27.DR.B28-1041	352	210	270	121	328	224	10 x 16	M12	48,2
38	28		400	420	28.DR.B28-8031	480	200	390	120	450	316	12 x 20	40 x 5	61
39	29		580	470	29.DR.B28-5331	480	210	390	130	450	316	12 x 20	40 x 5	73,5
40	30		660	530	30.DR.B22-4430	480	210	390	130	450	316	12 x 20	50 x 5	77

Connection of the input choke

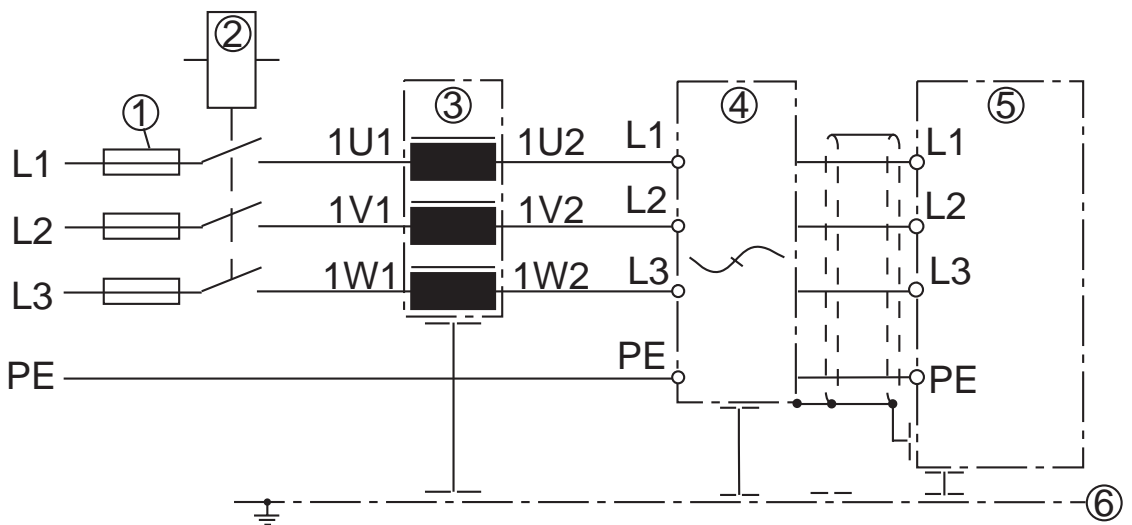

- ① Mains fuse
- ② Main protection
- ③ Input choke
- ④ Interference suppression filter
- ⑤ KEB COMBIVERT
- ⑥ Mounting plate

3.2.2 HF-Filter

The KEB COMBIVERT frequency inverters are optionally available with radio interference filters. Dependent on the housing size they are available as factory installed complete units (D-R Housing) or as filter assembly kits for local installation. The filter assembly kits contain the complete installation material incl. earth connection. They are ready for installation for max. 30 kW with connected lead wires at the filter output. Dependent on the available space and filter type the filter can either be installed under the frequency inverter (submounted), or beside the frequency inverter (side mounted).

All filters are dimensioned for the inverter and relate to the conducted emission in accordance with the limit curves EN 55011/B. When adhering to the specifications standard filters can be operated with a shielded motor cable up to 30 m.

For further filters e.g. for IT or delta networks, I/O filters or customized solutions please contact KEB.

Number	I [A]	Pv [W]	Kit incl. Filter	Filter	Submounting at housing type
HF-Filter, Phases 1, max. 240V (+10%)					
1	12	5	07.U4.00D-B606	07.E4.T60-0061	D
2	20	12	09.U4.00D-B601	09.E4.T60-0001	D
3	30	17,6	10.U4.00D-B601	10.E4.T60-0001	D
HF-Filter, Phases 3, max. 240V (+10%)					
4	8	7	10.U4.00D-BA01	10.E4.T60-1001	D
5	16	11,5	13.U4.00D-BA01	13.E4.T60-1001	D
6	30	21	13.U4.00E-BA01	15.E4.T60-1001	E
7	50	14	14.U4.00G-BA01	16.E4.T60-1001	G
8	70	15	15.U4.00H-BA01	18.E4.T60-1001	H
9	90	20	16.U4.00H-BA01	19.E4.T60-1001	H
10	110	60	17.U4.00R-BA01	20.E4.T60-1001	R
11	150	60	19.U4.00R-BA01	22.E4.T60-1001	R
12	180	40	23.U4.0RU-BM01	23.E4.T60-1001	-
13	250	50	25.U4.00U-BM01	25.E4.T60-1001	-
HF-Filter, Phases 3, max. 480V (+5%)					
14	8	7	10.U4.00D-BM01	10.E4.T60-1001	D
15	16	11,5	13.U4.00D-BM01	13.E4.T60-1001	D
16	20	14	14.U4.00E-BM01	14.E4.T60-1001	E
17	30	21	15.U4.00E-BM01	15.E4.T60-1001	E
18	20	14	14.U4.00G-BM01	14.E4.T60-1001	-
19	50	14	16.U4.00G-BM01	16.E4.T60-1001	G
20	50	14	16.U4.00H-BM01	16.E4.T60-1001	-
21	70	15	18.U4.00H-BM01	18.E4.T60-1001	H
22	90	20	19.U4.00H-BM01	19.E4.T60-1001	H
23	110	60	20.U4.00R-BM01	20.E4.T60-1001	R
24	150	60	22.U4.00R-BM01	22.E4.T60-1001	R*
25	180	40	23.U4.0RU-BM01	23.E4.T60-1001	-
26	250	50	25.U4.00U-BM01	25.E4.T60-1001	-
27	300	50	26.U5.A0U-3000	26.E4.T60-1001	-
28	330	75	27.U4.00U-BM01	27.E4.T60-1001	-
29	410	50	28.U4.00W-BM0S	28.E4.T60-1001	-
30	660	60	30.U5.A0W-3000	30.E4.T60-1001	-
31	1000	90	-	32.E4.T60-1001	-

GB

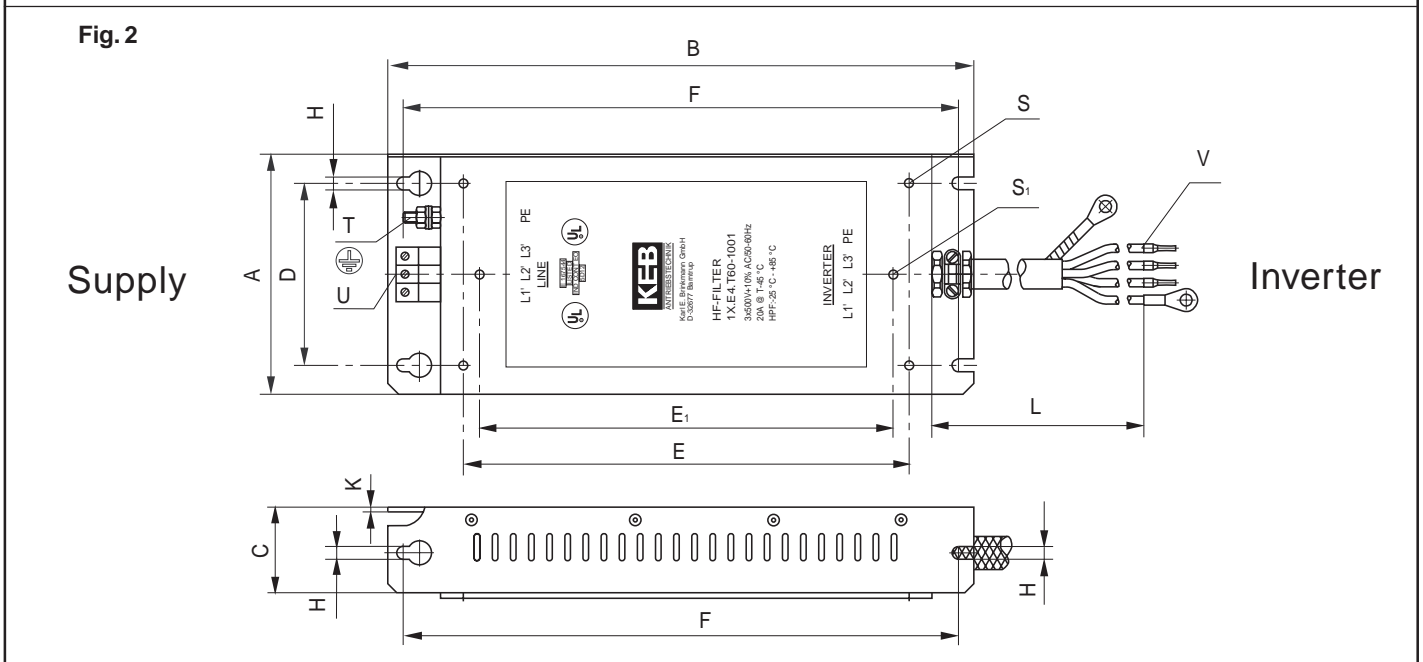
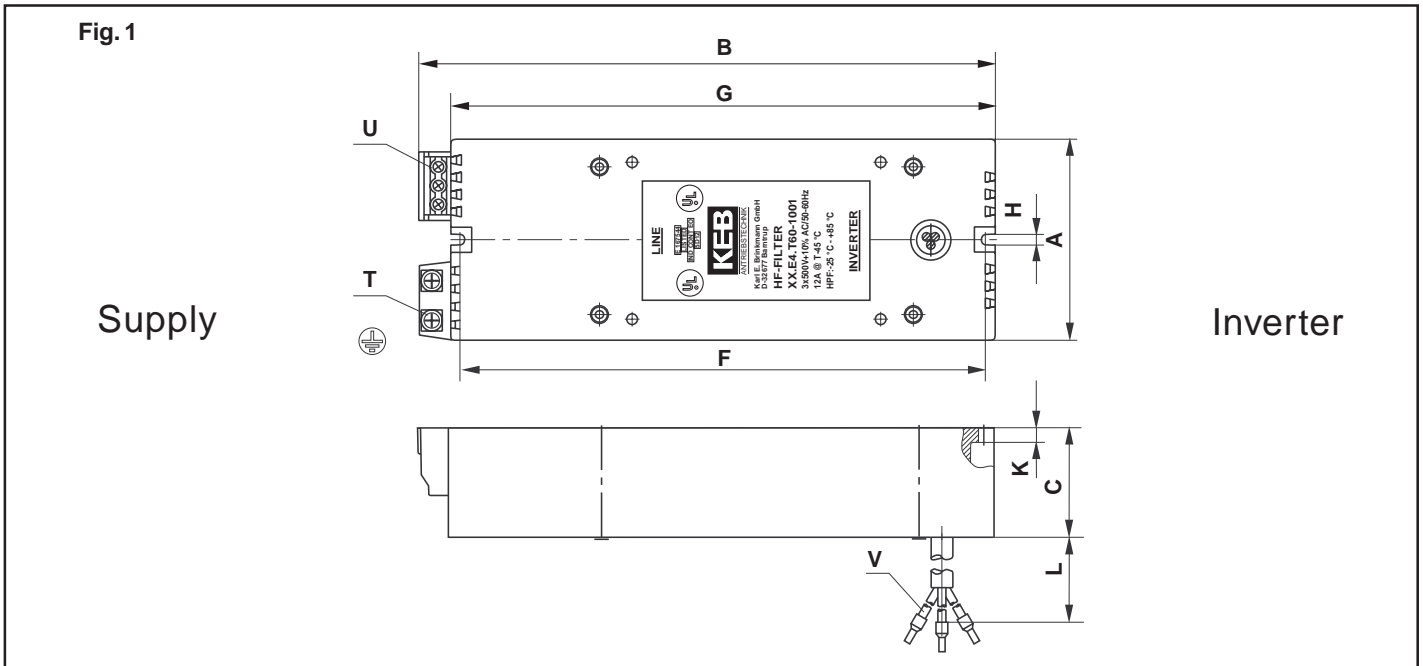

Rated current		U max. [V]	[A]	Fig.	A	B	C	D	E	E1	F	G	H	K	S	S1	T	LINE	INVERTER	L	Weight [kg]
Voltage	Terminal																	V			
KEB Art.No.:																					
07.E4.T60-0061	1x240 (+10%)	12	1	90	264	50	-	-	-	240	250	5	4	-	-	-	M4	2x 4mm ²	2x AWG 14	110	0,9
09.E4.T60-0001		20																2x AWG 10			
10.E4.T60-0001		30																2x AWG 10			
09.E4.T60-1001	3x480 (+5%)	8	2	132	352	50	100	-	275	335	-	7	3	-	M6	M6	3x 4mm ²	3x AWG 14	400	1,5	
10.E4.T60-1001		8															3x AWG 10				
13.E4.T60-1001		16															3x AWG 10				
14.E4.T60-1001	3x480 (+5%)	20	2	181	415	56	150	330	-	400	-	7	3	M6	-	M6	3x 10mm ²	4x AWG 10	400	3,2	
15.E4.T60-1001		30															3x AWG 6				
16.E4.T60-1001		50															3x AWG 6				
18.E4.T60-1001	3x480 (+5%)	70	2	300	445	66	250	330	-	420	-	7	4	M6	-	M6	3x 25mm ²	4x AWG 6	350	5,1	
19.E4.T60-1001		90															3x AWG 2	4x AWG 4			

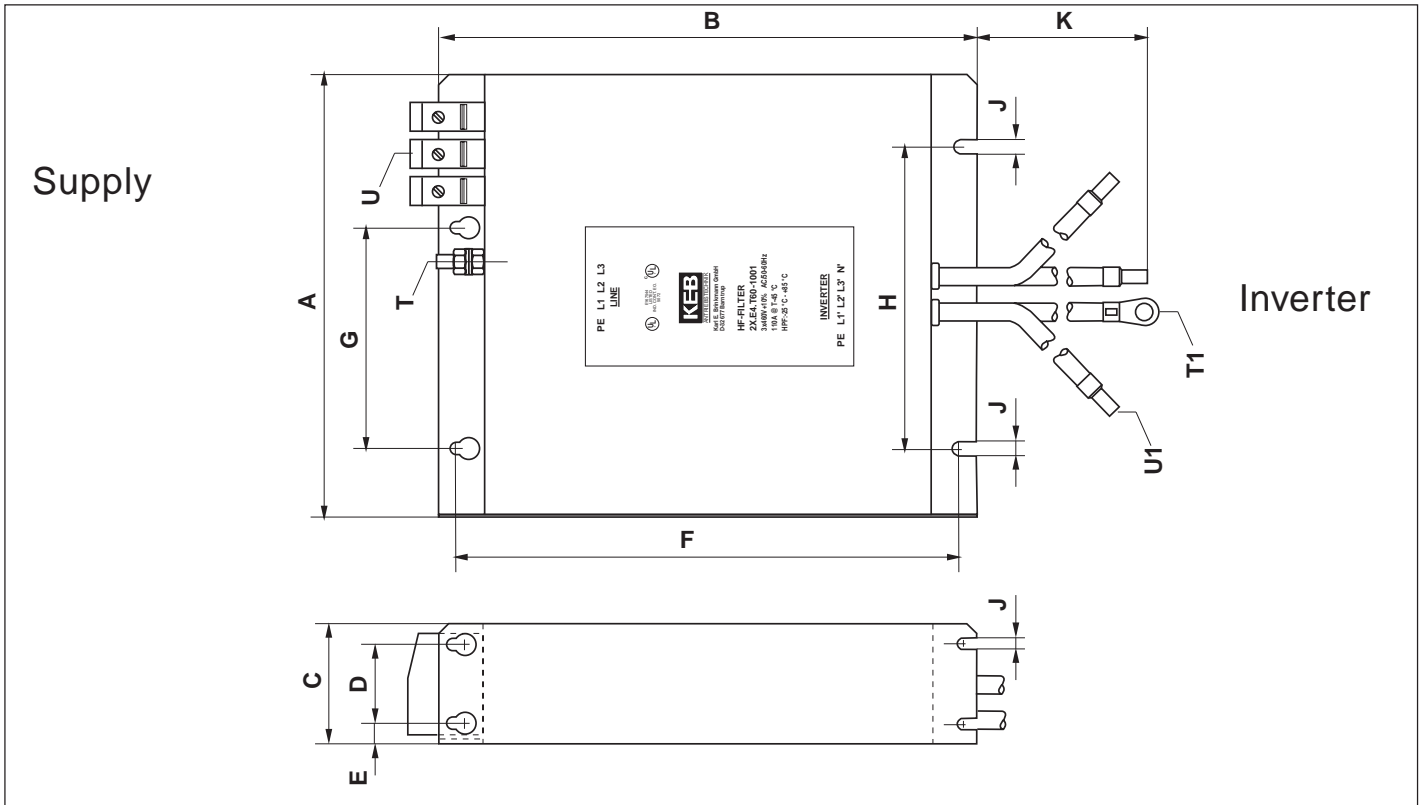

Rated current		Pv [W]	A	B	C	D	E	F	G	H	J	K	Line		Inverter		Weight [kg]
Mains voltage U _{max} .	KEB Art.Nr.:												T	U [mm ²]	T1	U1 [mm ²]	
3 x 480	20.E4.T60-1001	110	270	400	64	40	12	385	140	200	6,5	400	M8	3x 50	M8	3x25	8,5
(+5%)	22.E4.T60-1001	150														3x35	9,0

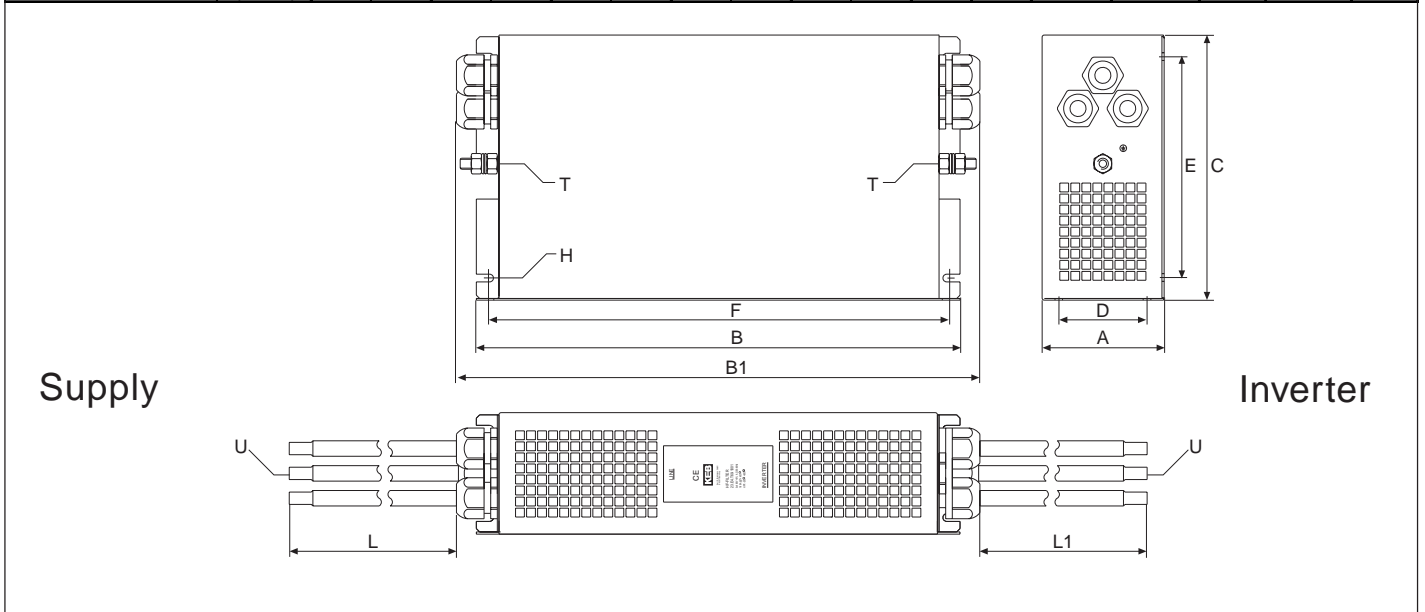

Rated current		Pv [W]	A	B	B1	C	D	E	F	H	L	L1	T	U [mm ²]	Weight [kg]
Voltage	U _{max} .														
3x	23.E4.T60-1001	40	110	438	474	240	80	200	414	6,5	1000	550	M10	3x50	13,0
480	25.E4.T60-1001	50		598	630				574			500		3x70	16,0
(+5%)	27.E4.T60-1001	75												3x95	18,0

GB

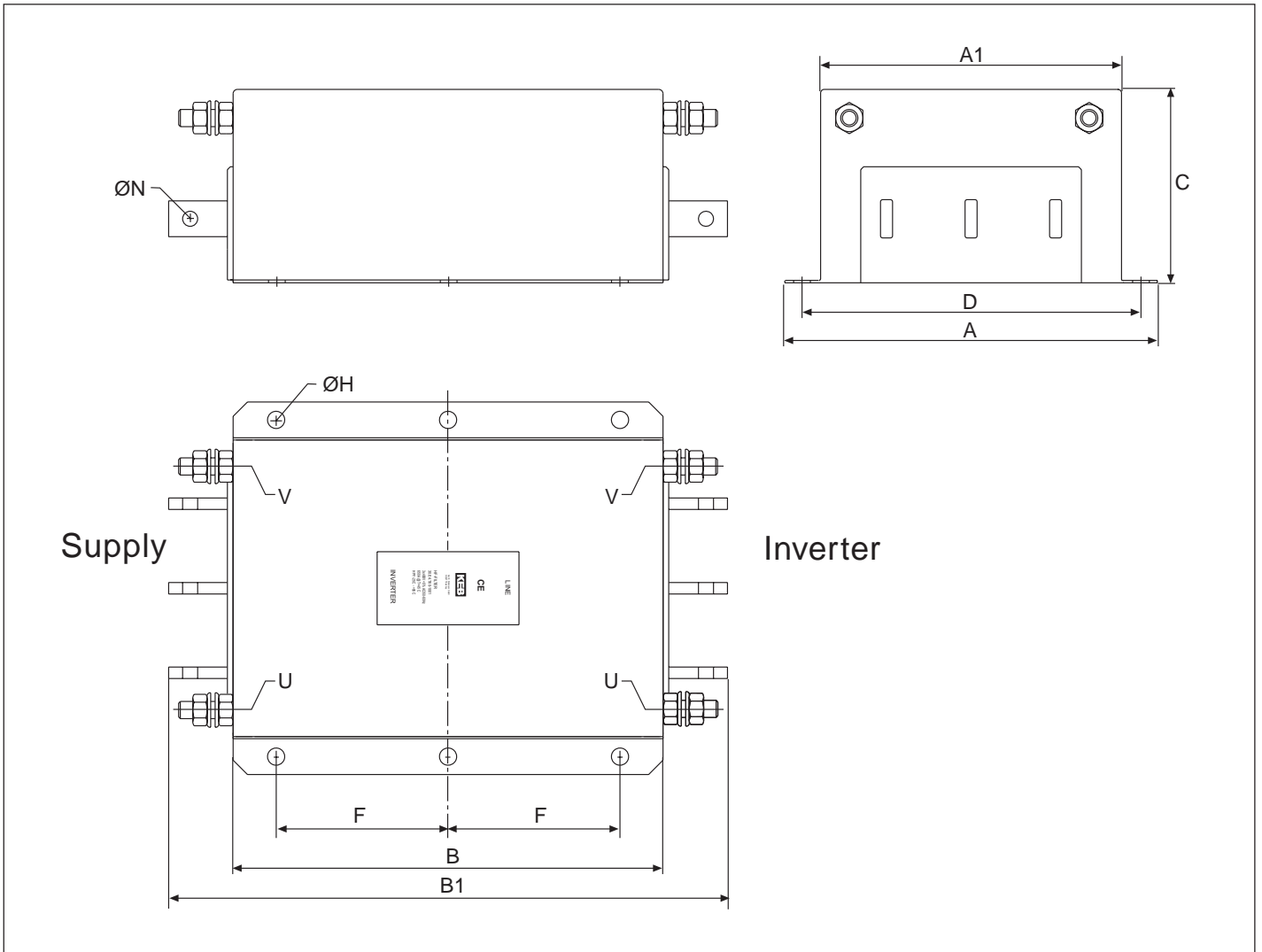

Rated current		Pv	A	A1	B	B1	C	D	F	H	N	U	V	Weight	
Voltage	U max.														
KEB Art.No.:	[V]	[A]	[W]											[kg]	
26.E4.T60-1001	3x 480 (+5%)	300	50	260	210	300	390	115	235	120	12	10,5	M12	-	14,0
28.E4.T60-1001		410	50					135							14,0
30.E4.T60-1001		650	60	280	230	350	440	185	255	145	14	-	M12	14,0	
32.E4.T60-1001		1000	90											17,0	

3.3 Output filter

3.3.1 Motor choke

The KEB output choke is a cost-effective possibility to reduce the voltage rise dv/dt , to avoid a premature age of the winding insulation of three-phase current motors. The KEB output choke can also be used for applications with long supply motor cables (>15m).

The following motor chokes are qualified for a max. motor frequency of 52 Hz. With a frequency range from 53 Hz... 60 the next size choke must be used. For motor frequencies > 60 Hz special chokes are available upon request.

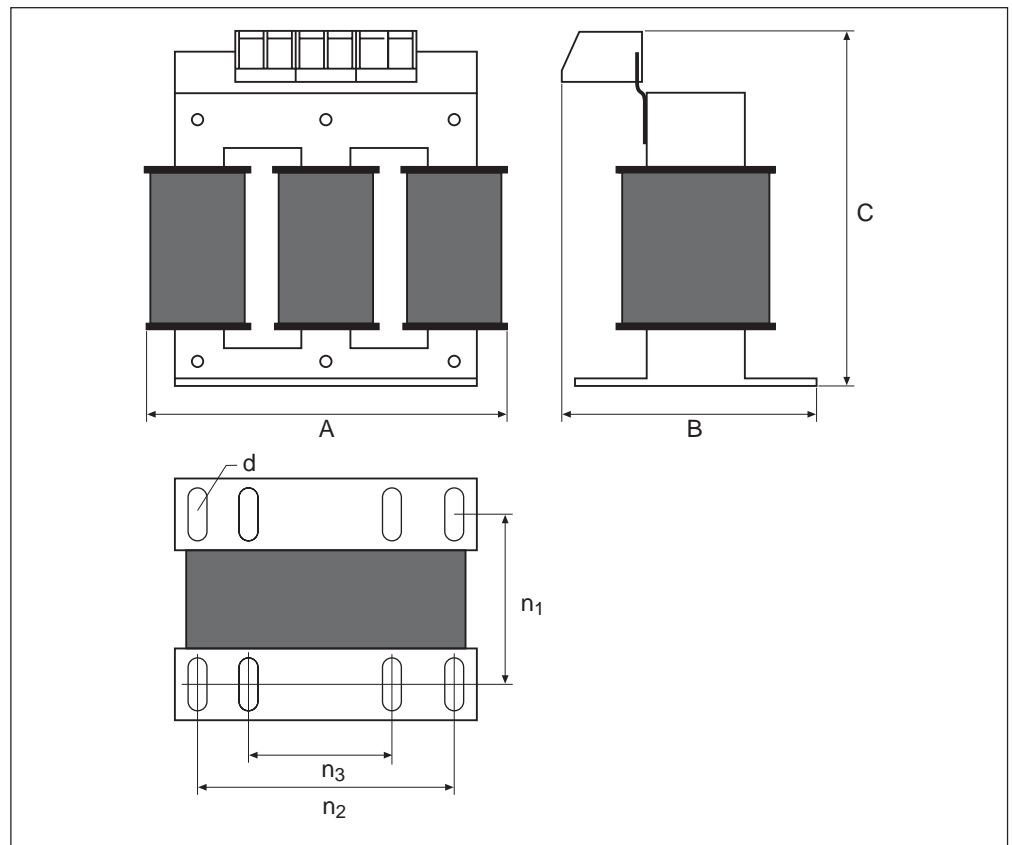

GB

230V-Class 4% terminal short circuit voltage														
Number	For COMBIVERT	Phases	I _{rated} [A]	P _{loss} [W]	Part number	Dimensions						Terminal [mm ²]	Weight [kg]	
						A	B	C	n ₁	n ₂	n ₃			d
2	05	3	4	14	05.DR.A08-4251	129	62	115	41	112	-	4,8 x 9	4	0,8
4	07	3	6	21	07.DR.A08-2851	129	62	115	41	112	-	4,8 x 9	4	1,2
6	09	3	8	21	09.DR.A08-2151	129	62	115	41	112	-	4,8 x 9	4	1,2
8	10	3	12	30	10.DR.A08-1551	129	72	115	50	112	-	4,8 x 9	4	1,8
10	12	3	20	30	12.DR.A08-8541	148	100	160	60	136	60	4,8 x 8	10	3
11	13	3	30	45	13.DR.A08-5641	148	100	160	60	136	60	4,8 x 8	10	3,7
12	14	3	40	50	14.DR.A08-4241	178	130	195	55	166	113	4,8 x 8	16	5
13	15	3	60	63	15.DR.A08-2841	178	145	235	70	166	113	4,8 x 8	16	6,4
14	16	3	70	74	16.DR.A08-2241	219	148	240	71	201	136	7 x 12	35	7,6
15	17	3	85	92	17.DR.A08-1841	219	170	255	81	201	136	7 x 12	95	10,5
16	18	3	100	90	18.DR.A08-1541	219	190	255	91	201	136	7 x 12	95	12
17	19	3	130	115	19.DR.A08-1241	267	195	300	81	249	176	7 x 12	95	15,3
18	20	3	160	155	20.DR.A08-1041	267	220	300	105	249	176	7 x 12	95	18
19	21	3	200	158	21.DR.A08-8031	267	215	310	102	249	176	7 x 12	95	29
20	22	3	230	170	22.DR.A08-6031	267	235	335	116	249	176	7 x 12	150	31

GB

400V-Class 4% terminal short circuit voltage														
Number	For COMBIVERT	Phases	I _{rated} [A]	P _{loss} [W]	Part number	Dimensions							Terminal [mm ²]	Weight [kg]
						A	B	C	n ₁	n ₂	n ₃	d		
19	05	3	4	22	05.DR.B08-7351	129	72	115	50	112	-	4,8 x 9	2,5	1,35
20	07, 09		6	22	07.DR.B08-4951	129	72	115	50	112	-	4,8 x 9	2,5	1,6
21	10		8	33	10.DR.B08-3751	148	80	140	60	136	90	4,8 x 8	2,5	2,5
22	12		10	33	12.DR.B08-2851	148	80	140	60	136	60	4,8 x 8	2,5	2,5
23	13		16	53	13.DR.B08-1851	178	95	165	55	166	113	4,8 x 8	2,5	5,2
24	14		20	54	14.DR.B08-1451	178	95	165	55	166	113	4,8 x 8	4	5,4
25	15		30	76	15.DR.B08-9841	178	110	175	70	166	113	4,8 x 8	10	5,8
26	16		40	76	16.DR.B08-7341	178	110	175	70	166	113	7 x 12	10	6,8
27	17		50	97	17.DR.B08-5941	219	100	200	71	201	136	7 x 12	10	8
28	18		60	100	18.DR.B18-4941	219	110	200	81	201	136	7 x 12	10	9,8
29	19		75	110	19.DR.B18-3941	219	160	235	91	201	136	7 x 12	35	13,1
30	20		90	151	20.DR.B18-3341	267	186	285	81	249	176	7 x 12	35	15,6
31	21		115	181	21.DR.B18-2841	267	210	275	105	249	176	7 x 12	35	21,9
32	22		150	205	22.DR.B18-2241	316	200	330	99	292	200	9 x 13	95	24,7
33	23		180	145	23.DR.B18-1741	267	207	310	94	249	176	7 x 12	95	24,1
34	24		200	168	24.DR.B18-1541	267	215	310	102	249	176	7 x 12	95	28,3
35	25		230	230	25.DR.B18-1341	267	230	335	111	249	176	9 x 13	150	30
36	26		270	290	26.DR.B28-1141	352	230	400	105	328	224	10 x 16	240	37,3
37	27		300	308	27.DR.B28-1041	352	210	270	121	328	224	10 x 16	M12	48,2
38	28		400	420	28.DR.B28-8031	480	200	390	120	450	316	12 x 20	40 x 5	61
39	29		580	470	29.DR.B28-5331	480	210	390	130	450	316	12 x 20	40 x 5	73,5
40	30		660	530	30.DR.B22-4430	480	210	390	130	450	316	12 x 20	50 x 5	77

Connection of the motor choke

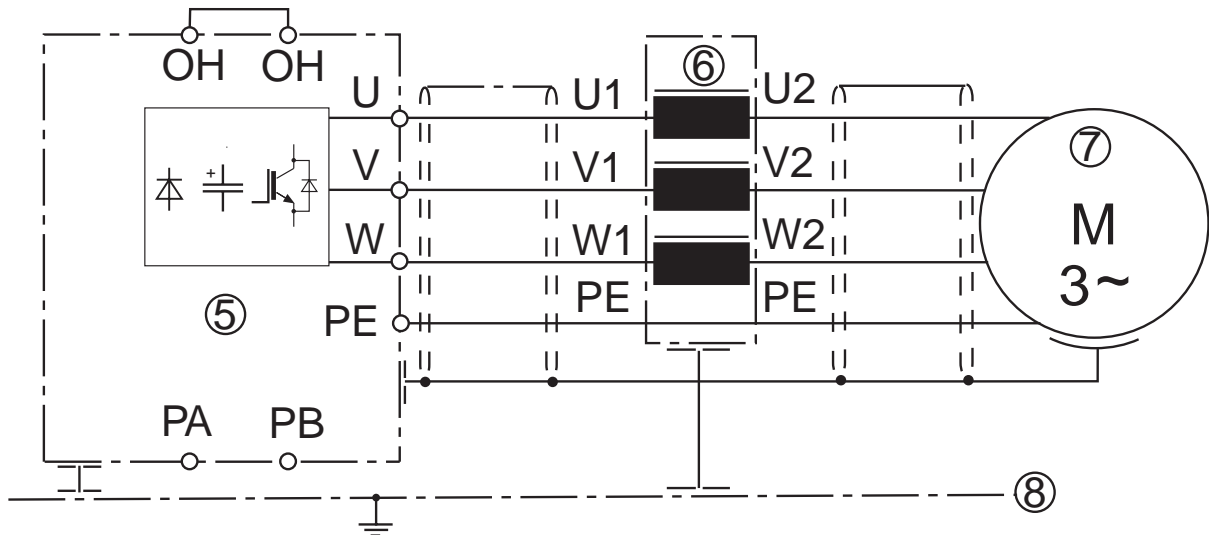

- ⑤ KEB COMBIVERT
- ⑥ Motor choke

- ⑦ Motor
- ⑧ Mounting plate

3.3.2 Sinus filter

Via the pulse duration modulation output voltage of the frequency inverters a voltage rise of du/dt of 5...10 kV/ μ s can occur dependent on the used power modules, control process, motor line length and type of the motor. Installation of KEB sinus filters reduce the speed of the voltage rise between the phases of mains conditions, that no negative influences to the long-time behaviour of the winding insulation of three-phase current motors have to be expected. The standard-sinus filters are made for an output frequency of max. 120 Hz.

GB

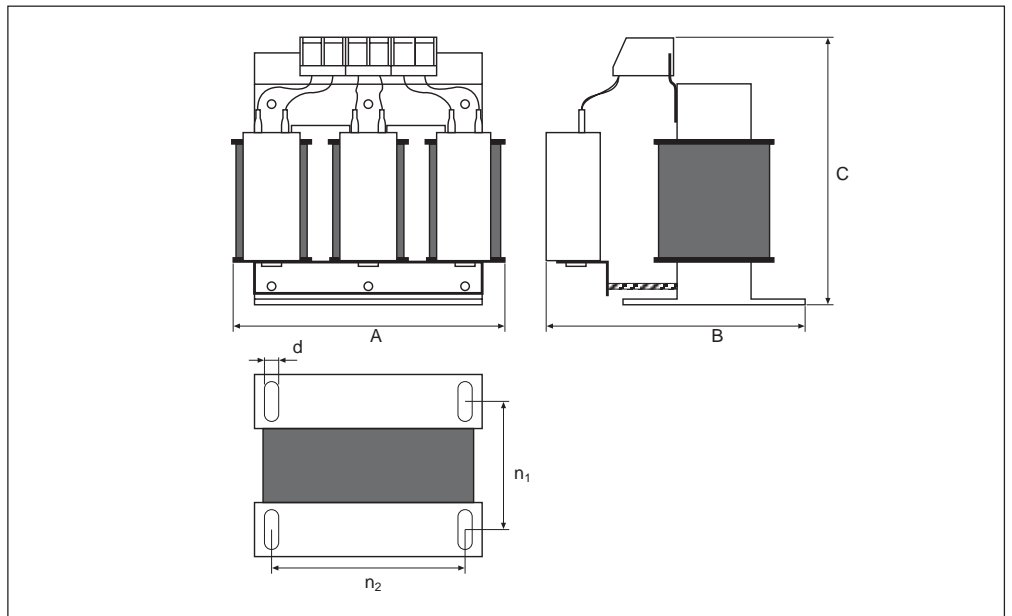

230V-Class, up to f_{out} max. 120Hz, for 4kHz switching frequency, IP00, VBG4, T 40/F

Number	For COMBIVERT	Part number	I_N [A]	Dimensions			Mounting			Terminals [mm ²]	Weight [kg]
				A	B	C	n1	n2	d		
1	07	00.90.428-5099	4,1	125	110	180	55	100	8	4	3,2
2	09	00.90.428-5129	9,5	155	130	210	72	130	8	4	6,8
3	10	00.90.428-5139	12	190	140	220	58	170	8	10	8
4	12	00.90.428-5149	16,5	190	150	220	68	170	8	10	12
5	13	00.90.428-5159	24	210	165	240	82	180	8	10	12
6	14	00.90.428-5169	33	240	195	280	106	190	11	16	20
8	15	00.90.428-5189	50	240	220	295	126	190	11	35	30
9	16	00.90.428-5199	60	300	355	355	121	240	11	35	38

400V-Class, f_{out} max. 120Hz, IP00, VBG4, T 40/F												
Number	For COMBIVERT	min. Switching freq.	Part number	I_N [A]	Dimensions			Mounting			Terminals [mm ²]	Weight [kg]
					A	B	C	n1	n2	d		
1	07/09	4 kHz	00.90.428-5099	4,1	125	110	180	55	100	8	4	3,2
2	10/12	4 kHz	00.90.428-5129	9,5	155	130	210	72	130	8	4	6,8
3	13	4 kHz	00.90.428-5139	12	190	140	220	58	170	8	10	8
4	14	4 kHz	00.90.428-5149	16,5	190	150	220	68	170	8	10	12
5	15	4 kHz	00.90.428-5159	24	210	165	240	82	180	8	10	12
6	16	4 kHz	00.90.428-5169	33	240	195	280	106	190	11	16	20
7	17	4 kHz	00.90.428-5179	42	240	220	295	126	190	8	35	30
8	18	4 kHz	00.90.428-5189	50	240	220	295	126	190	11	35	30
9	19	4 kHz	00.90.428-5199	60	300	355	355	121	240	11	35	38
10	20	4 kHz	00-90.428-5209	75	300	240	355	134	240	11	35	42
11	21	4 kHz	00-90.428-5219	90	300	255	360	146	240	11	50	50
12	22	4 kHz	00-90.428-5229	115	360	260	405	126	310	11	70	60
13	23	4 kHz	00-90.428-5239	152	360	280	420	141	310	11	95	70
14	24	4 kHz	00-90.428-5249	180	360	305	440	156	310	11	150	85
15	25	4 kHz	00-90.428-5259	210	420	290	495	152	370	11	150	110
16	26	4 kHz	00-90.428-5269	250	420	320	495	182	370	11	150	130
17	27	2 kHz	00-90.428-5279	300	420	420	495	212	370	11	150	160
18	28	2 kHz	00-90.428-5289	370	480	450	560	240	430	11	240	250
19	29	2 kHz	00-90.428-5299	450	480	450	560	240	430	11	240	250

Connection of the sinus filter

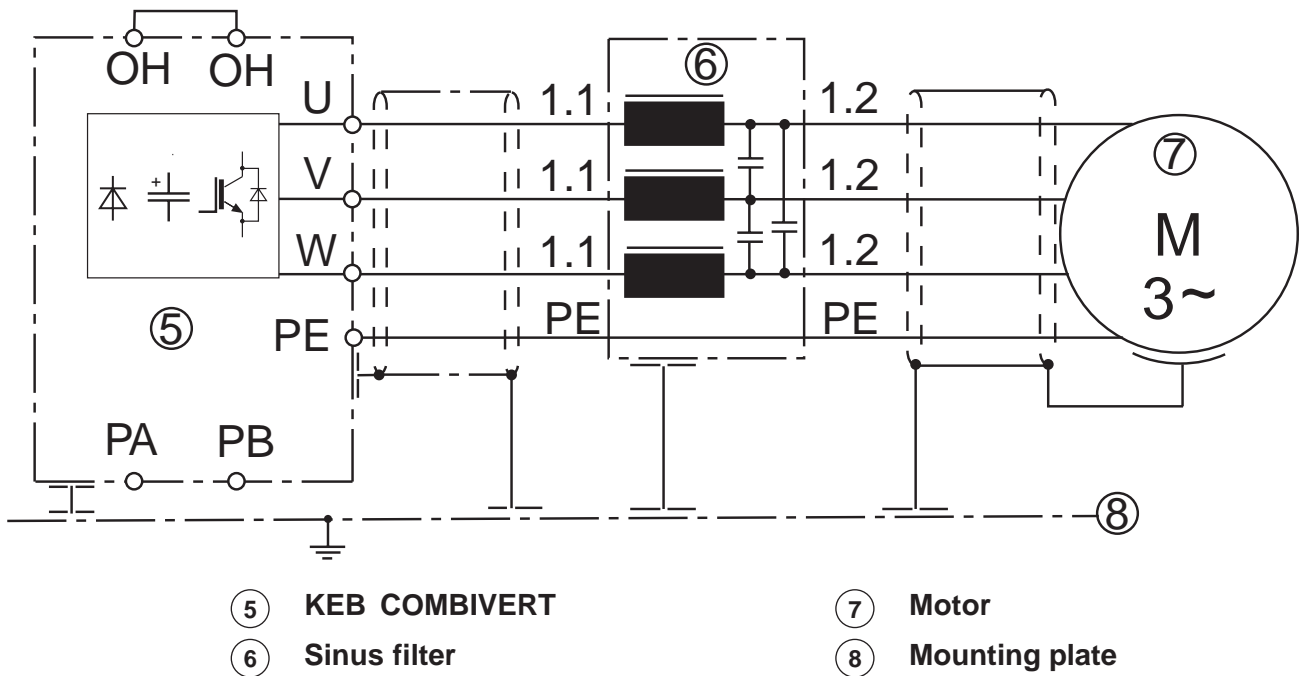

3.3.3 Sinus filter plus

The KEB sinus filter enables a sinusoidal voltage characteristic of the motor terminal voltage between the phases and against earth. Extremely long motor lines can be realized without shielding or later installation of FU's can be done without any problems in already existing units. The legal limits of interference are observed.

Information about dimension: With loads >150% inverter-rated current (I_N) the next higher filter must be used. Min. 8 kHz (better 16 kHz) carrier frequency are required. The filter is dimensioned to max. output frequency of 100 Hz.

GB

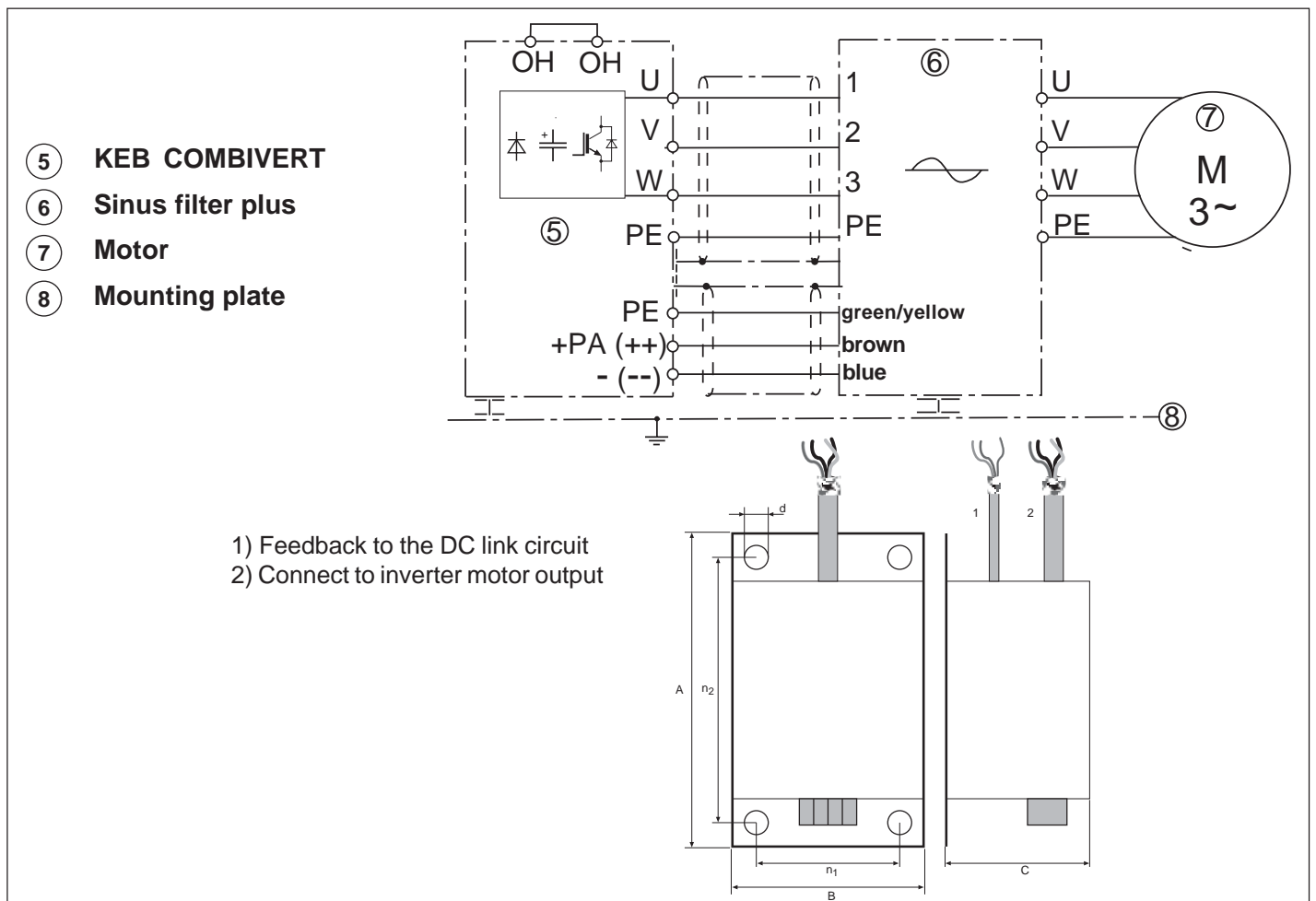

400V-Class, f_{out} max. 100Hz, for min. 8kHz switching frequency, IP20, VBG4, T 40/F

Number	For COMBIVERT	Part Number	I_N [A]	Dimensions			Mounting			Terminals [mm ²]	Weight [kg]
				A	B	C	n1	n2	d		
1	07/09	00.90.426-5099	4	390	90	150	44	373	6,5	4	11,5
2	10	00.90.426-5119	8	390	90	180	44	370	8,7	4	15
3	12/13	00.90.426-5139	12	390	90	215	44	370	8,7	10	18,5
4	14	00.90.426-5149	16	350	140	230	95	330	8,7	10	23
5	15	00.90.426-5159	25	390	165	230	135	370	8,7	10	25

4. Annex

4.1 Overload curve

① Inverter size ≤ 24

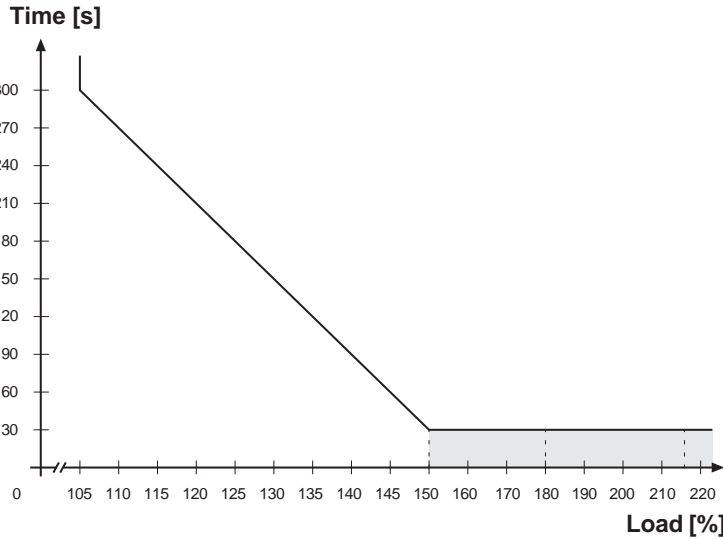

② Inverter size ≥ 25

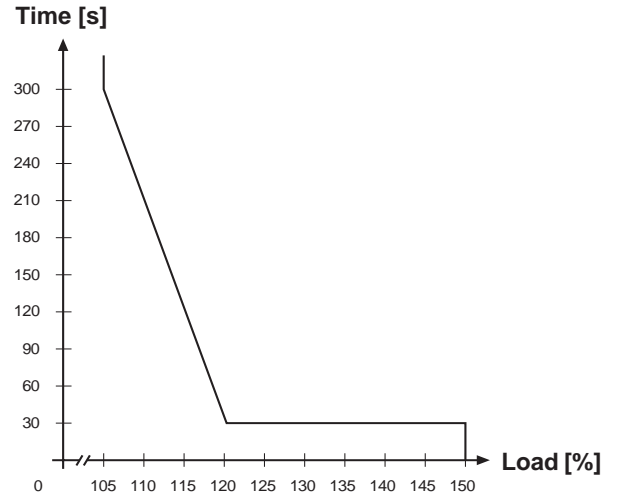

The characteristic declines device-dependently in this range (see technical data)

4.2 Overload protection in the lower speed range (only valid for F4-F, stall current see Page 9-13)

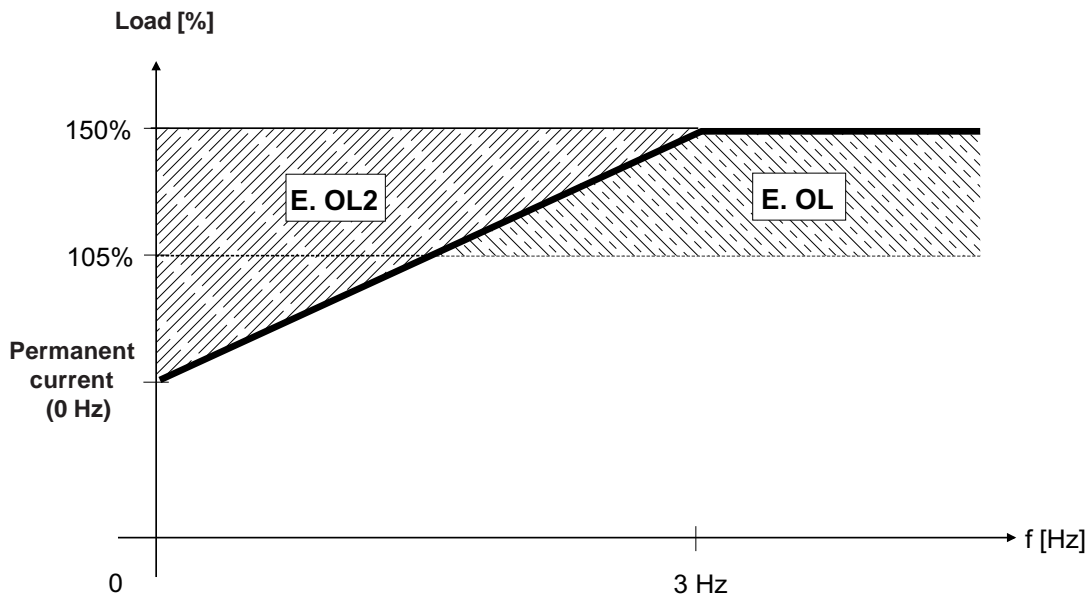

$$I_{T_K} = \text{stall current} \times \frac{180^\circ\text{C} - T_K}{180^\circ\text{C} - T_{OH}}$$

T_{OH} = Max.Heat sink temperature before error OH

T_K = Heat sink temperature

D

Vor Auslieferung durchlaufen alle Produkte mehrfach eine Qualitäts- und Funktionskontrolle, so daß Fehler auszuschließen sind. Bei Beachtung unserer Betriebsanleitung sind keine Störungen zu erwarten. Sollte sich trotzdem ein Grund zur Reklamation ergeben, so ist das Gerät mit Angabe der Rechnungsnummer, des Lieferdatums, der Fehlerursache und den Einsatzbedingungen an uns zurückzusenden. Für Fehler, die aufgrund falscher Behandlung, falscher Lagerung oder sonstigen allgemeinen Irrtümern auftreten, übernehmen wir keine Verantwortung. Prospekte, Kataloge und Angebote enthalten nur Richtwerte. Technische Änderungen jeder Art behalten wir uns vor. Alle Rechte vorbehalten. Nachdruck, Vervielfältigung und fotomechanische Wiedergabe sind ohne schriftliche Genehmigung durch KEB auch auszugsweise verboten.

GB

Prior to delivery all products pass several quality and performance inspections so that malfunctions can be ruled out. When used in accordance with the operating instructions failure is most unlikely. However, if you have cause for complaint the unit should be returned stating invoice number, delivery date, cause of failure and field conditions. We do not accept the responsibility for failures due to misuse, wrong storage or similar causes. Leaflets, catalogues and quotations contain only standard values. We reserve the right to make technical changes without obligation. All rights reserved. Any piratic printing, mimeographing or photomechanical reproduction, even in extracts, is strictly prohibited.

E

Antes de ser enviados todos los productos pasan severos controles de calidad por lo que pueden descartarse defectos. Cuando sea utilizado de acuerdo con las instrucciones de operación una avería no es nada probable. Sin embargo, si tiene motivo de reclamación la unidad podría devolverse indicando número de factura, fecha de entrega, causa del fallo y condiciones de instalación. Nosotros no aceptamos la responsabilidad por fallos debidos a mal uso, almacenaje incorrecto o causa similar. Los folletos, catalogues y ofertas contienen sólo valores estándar. Nos reservamos el derecho de modificar el equipo sin ninguna obligación. Todos los derechos reservados. Cualquier impresión pirata, reproducción mimeografía o fotomecánica, incluso en parte, está estrictamente prohibida.

I

Prima di essere spediti, tutti i nostri prodotti sono soggetti a severi controlli di qualità e funzionamento, questo al fine di evitare malfunzionamenti. Se utilizzati seguendo il manuale di istruzione si evita qualsiasi malfunzionamento. Comunque, qualora dovesse verificarsi un guasto, l'unità dovrà essere rispedita specificando il numero di bolla, la data di spedizione, i dettagli del guasto ed il tipo di applicazione. Non si assumono responsabilità per errori dovuti a manomissioni, cattivo stoccaggio o simili. Ci riserviamo di effettuare qualsiasi modifica senza preavviso alcuno. Tutti i diritti sono riservati. Qualsiasi riproduzione non autorizzata, anche parziale, è rigorosamente proibita.

RU

Перед отгрузкой все изделия неоднократно проходят проверку на предмет качества и работоспособность, так что брак исключается. При соблюдении нашего руководства по эксплуатации появление неисправностей не ожидается. Если вопреки этому, всё таки появятся основания для рекламации, изделие необходимо отправить на наш адрес с указанием номеров товарной накладной и счёта, датой поставки, причиной приведшей к выходу изделия из строя и условий эксплуатации.

Фирма КЕВ не несёт ответственность за выход изделий из строя по причинам не правильного хранения, транспортировки, неправильного обращения и других ошибочных действий. Проспекты, каталоги и коммерческие предложения содержат только ориентировочные значения. Мы оставляем, за собой право вносить технические изменения любого рода. Все права принадлежат нам. Размножение, перепечатывание, фотомеханическое воспроизведение, даже частичное, без письменного разрешения на то фирмы КЕВ запрещено.

F

Avant la livraison tous les produits passent par différents contrôles fonctionnels et qualitatifs de manière à éliminer les mauvais fonctionnements. L'apparition de défauts sur ces produits est très improbable s'ils sont raccordés et utilisés selon les recommandations des manuels d'instructions. Néanmoins, si un défaut apparaissait, le matériel doit être retourné en indiquant le numéro du bon de livraison, la date d'expédition et les détails apparents du défaut ainsi que le type d'application. Un mauvais emploi, de mauvaises conditions de stockage ou d'autres causes de ce type excluent notre responsabilité en cas de défectuosité. Les documents techniques et commerciaux, les offres de prix ne contiennent que des valeurs standards. Nous nous réservons le droit de procéder à des modifications techniques sans préavis. Tout droit réservé. Toutes contrefaçons imprimées, ou reproductions photomécaniques; même partielles, sont strictement interdites.



Karl E. Brinkmann GmbH

Försterweg 36 - 38 • D - 32683 Barntrup
Telefon 00 49 / 52 63 / 4 01 - 0 • Fax 00 49 / 52 63 / 4 01 - 1 16
Internet: www.keb.de • E-mail: info@keb.de

KEB Antriebstechnik GmbH & Co. KG

Wildbacher Str. 5 • D - 08289 Schneeberg
Telefon 0049 / 37 72 / 67 - 0 • Telefax 0049 / 37 72 / 67 - 2 81
E-mail: info@keb-combidrive.de

KEB Antriebstechnik Austria GmbH

Ritzstraße 8 • A - 4614 Marchtrenk
Tel.: 0043 / 7243 / 53586 - 0 • FAX: 0043 / 7243 / 53586 - 21
Kostelni 32/1226 • CZ - 370 04 České Budejovice
Tel.: 00420 / 38 / 731 92 23 • FAX: 00420 / 38 / 733 06 97
E-mail: info@keb.at

KEB Antriebstechnik

Herenveld 2 • B - 9500 Geraadsbergen
Tel.: 0032 / 5443 / 7860 • FAX: 0032 / 5443 / 7898
E-mail: koen.detaeye@keb.de

KEB China

Xianxia Road 299 • CHN - 200051 Shanghai
Tel.: 0086 / 21 / 62350922 • FAX: 0086 / 21 / 62350015
Internet: www.keb-cn.com • E-mail: info@keb-cn.com

Société Française KEB

Z.I. de la Croix St. Nicolas • 14, rue Gustave Eiffel
F - 94510 LA QUEUE EN BRIE
Tél.: 0033 / 1 / 49620101 • FAX: 0033 / 1 / 45767495
E-mail: sfkeb.4@wanadoo.fr

KEB (UK) Ltd.

6 Chieftain Buisness Park, Morris Close
Park Farm, Wellingborough, GB - Northants, NN8 6 XF
Tel.: 0044 / 1933 / 402220 • FAX: 0044 / 1933 / 400724
Internet: www.keb-uk.co.uk • E-mail: info@keb-uk.co.uk

KEB Italia S.r.l.

Via Newton, 2 • I - 20019 Settimo Milanese (Milano)
Tel.: 0039 / 02 / 33500782 • FAX: 0039 / 02 / 33500790
Internet: www.keb.it • E-mail: kebitalia@keb.it

KEB - YAMAKYU Ltd.

15 - 16, 2 - Chome, Takanawa Minato-ku
J - Tokyo 108 -0074
Tel.: 0081 / 33 / 445-8515 • FAX: 0081 / 33 / 445-8215
E-mail: kebjt001@d4.dion.ne.jp

KEB Portugal

Lugar de Salgueiros - Pavilhao A, Mouquim
P - 4760 V. N. de Famalicao
Tel.: 00351 / 252 / 371 318 • FAX: 00351 / 252 / 371 320
E-mail: keb.portugal@netc.pt

KEB Taiwan Ltd.

1F, No.19-5, Shi Chou Rd., Tounan Town
R.O.C. - Yin-Lin Hsian / Taiwan
Tel.: 00886 / 5 / 5964242 • FAX: 00886 / 5 / 5964240
E-mail: keb_taiwan@mail.apol.com.tw

KEBCO Inc.

1335 Mendota Heights Road
USA - Mendota Heights, MN 55120
Tel.: 001 / 651 / 4546162 • FAX: 001 / 651 / 4546198
Internet: www.kebco.com • E-mail: info@kebco.com