

ME-30-P series

[Square Wave/Incremental]

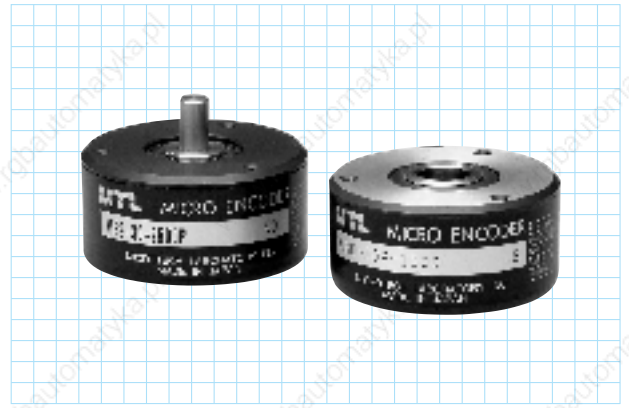

Outside dimensions

MES-30-P

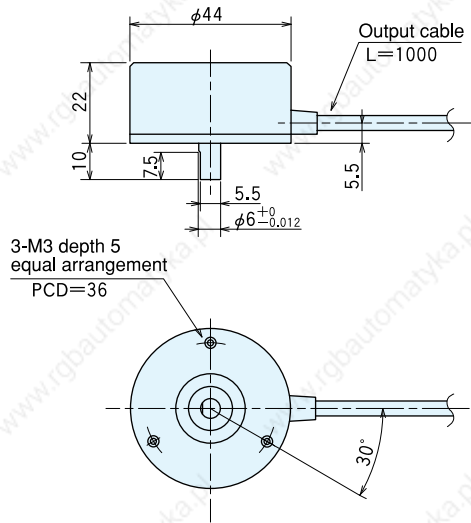

MEH-30-P

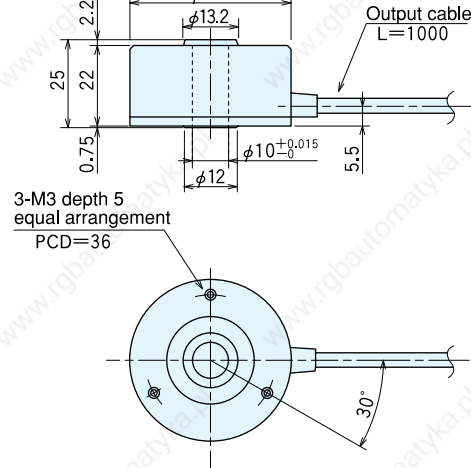

Specifications

Type name		ME□-30-□P□		
Item	Shaft shape	●S=single shaft	●H=hollow shaft	
	Pulse number	●C4=open collector output DC24V	●S=sine wave output	
Supply voltage	DC5~12V ±10%			
	DC24V±10%(open collector output only)			
Current consumption	50mA or less (under no load)			
Detection system	Incremental			
Output	Output pulse number (Standard) [Pulse number/rotation]	40	250	500
		50	300	512
		60	360	600
		100	400	
		200	450	
		720	2,000	10,800
Output phase	A, B, Z phase			
Output form	Square wave			
Output capacity	Sink current: 20mA Residual voltage: 0.5V or less (at 10mA)			
Maximum response frequency (response pulse number)	100kHz			
Output phase difference	A, B phase difference 90°±45° (T/4±T/8) Z phase T±T/2 (see Output Waveform)			
Waveform rise/fall time	2μs or less (output cable 1m or less)			
Starting torque	2×10 ⁻³ N·m (20gf·cm) or less			
Allowable load of shaft (electrical)	Radial	19.6N (2kgf)	14.7N (1.5kgf)	
	Thrust	9.8N (1kgf)	4.9N (0.5kgf)	
Maximum allowable revolutions (mechanical)	6,000r/min			
Working ambient temperature/humidity	-10°C~70°C RH35%~90% no dewing			
Storing ambient temperature	-20°C~80°C			
Vibration resistance	Durability 55Hz, double amplitude 1.5mm 2 hours each in X, Y, and Z directions			
Impact resistance	Durability 500m/s ² (about 50G) 3 times each in X, Y, and Z directions			
Cable	Outside diameter φ4.2 5-core vinyl wire Insulated shield cable (length 1m)			
Mass	140g			

Output circuit diagram

Voltage output (standard type)

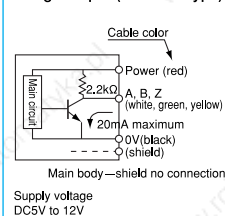

Open collector output (option)

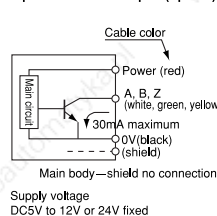

Line driver output (option)

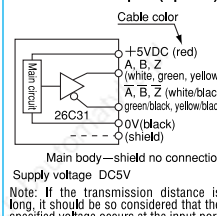

A capacitor (0.1μF) is connected between 0V and FG (frame ground).

Output waveform

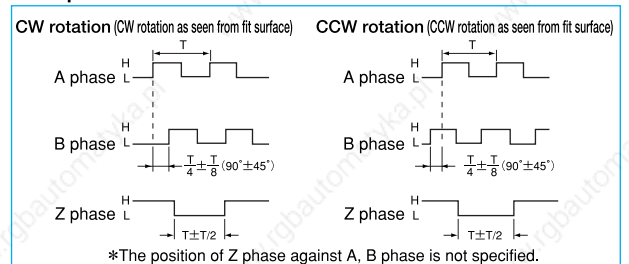

Specifications/Sine wave

Supply voltage	DC5V ±5%	
Current consumption	40mA or less (under no load)	
Detection system	Sine wave·Incremental	
Output pulse number (Standard) [Pulse number/rotation]	1,000	2,048
	1,500	3,600
	1,800	4,500
	2,000	
Output phase	A, B, Z phase	
Output form	A, B phase SIN wave, Z phase square wave	
A, B, Z phase output	SIN wave 1.5 V _{p-p} ±0.3 V offset 2.0V±0.2V	
	Opamp output current 5mA Max.	
	Harmonic distortion factor to be within 10% (Measuring condition to be within 20 kHz, effective value mean distortion factor measuring instrument)	
Maximum response frequency	50kHz	
Output phase difference	A, B phase difference 90°±45° (T/4±T/8) Z phase T±T/2 (see Output Waveform)	
Starting torque	2×10 ⁻³ N·m (20gf·cm) or less	
Allowable load of shaft (electrical)	Radial	14.7N (1.5kgf)
	Thrust	4.9N (0.5kgf)
Maximum allowable revolutions (mechanical)	6,000r/min	
Working ambient temperature/humidity	0°C~50°C RH35%~90% no dewing	
Storing ambient temperature	-20°C~80°C	
Vibration resistance	Durability 55Hz, double amplitude 1.5mm 2 hours each in X, Y, and Z directions	
Impact resistance	Durability 500m/s ² (about 50G) 3 times each in X, Y, and Z directions	
Cable	Outside diameter φ4.2 5-core vinyl wire Insulated shield cable (length 1m)	
Mass	140g	

Output circuit diagram

Sine wave output (option)

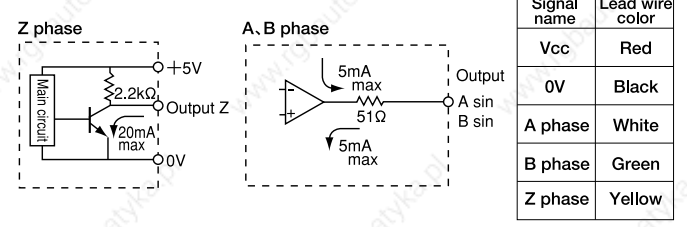

A capacitor (0.1 μF) is connected between 0V and FG (frame ground).

Output waveform

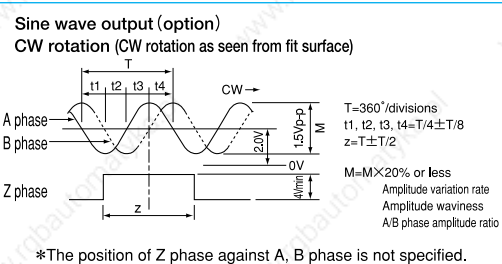

Specifications Built-in multiplication circuit (X2·X4·X8·X16)

Supply voltage	Voltage:DC5V-5%~12V+10% Open collector:DC5V-5%~24V+10% Line driver:DC5V±5%	
Current consumption	80mA or less (under no load)	
Detection system	Incremental	
Output pulse number (Standard) [Pulse number/rotation]	EX	4,500×2 (9,000)
		4,500×4 (18,000)
		4,500×8 (36,000)
		4,500×16 (72,000)
Output phase	A, B, Z phase	
Output form	Square wave	
Maximum response frequency	Line driver output:50kHz× (by multiplication) Voltage output·Open collector output:100kHz	
Output phase difference	See the diagram below.	
Starting torque	2×10 ⁻³ N·m (20gf·cm) or less	
Allowable load of shaft (electrical)	Radial	14.7N (1.5kgf)
	Thrust	4.9N (0.5kgf)
Maximum allowable revolutions (mechanical)	6,000r/min	
Working ambient temperature/humidity	-10°C~70°C RH35%~90% no dewing	
Storing ambient temperature	-20°C~80°C	
Vibration resistance	Durability 55Hz, double amplitude 1.5mm 2 hours each in X, Y, and Z directions	
Impact resistance	Durability 500m/s ² (about 50G) 3 times each in X, Y, and Z directions	
Cable	Outside diameter φ4.2 5-core vinyl wire Insulated shield cable (length 1m)	
Mass	140g	

Output circuit diagram

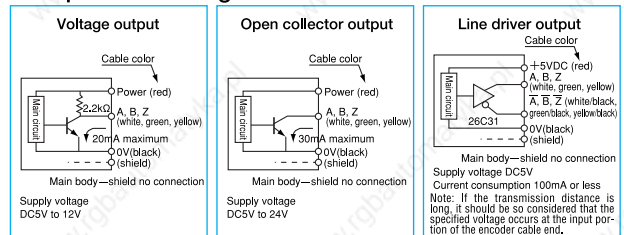

A capacitor (0.1 μF) is connected between 0V and FG (frame ground).

Output waveform

