

# Rexroth IndraDrive Drive System

R911309636  
Edition 04

## Project Planning Manual



**Title** Rexroth IndraDrive  
Drive System

**Type of Documentation** Project Planning Manual

**Document Typecode** DOK-INDRV\*-SYSTEM\*\*\*\*\*-PR04-EN-P

**Internal File Reference** RS-133519800a6846ac00a015a26f840210-1-en-US-3

**Record of Revision**

Edition	Release Date	Notes
120-2400-B321-04/EN	2007/08	Changes: see chapter "Introducing the System" → "Documentation" → "About This Documentation" → "Changes in Comparison to Previous Edition"

**Copyright** © 2007 Bosch Rexroth AG

Copying this document, giving it to others and the use or communication of the contents thereof without express authority, are forbidden. Offenders are liable for the payment of damages. All rights are reserved in the event of the grant of a patent or the registration of a utility model or design (DIN 34-1).

**Validity** The specified data is for product description purposes only and may not be deemed to be guaranteed unless expressly confirmed in the contract. All rights are reserved with respect to the content of this documentation and the availability of the product.

**Published by** Bosch Rexroth AG  
Bgm.-Dr.-Nebel-Str. 2 ■ D-97816 Lohr a. Main  
Telephone +49 (0)93 52/ 40-0 ■ Fax +49 (0)93 52/ 40-48 85  
<http://www.boschrexroth.com/>  
Dept. BRC/EDY1

**Note** This document has been printed on chlorine-free bleached paper.

# Table of Contents

	Page
<b>1</b>	<b>Introducing the System..... 1</b>
1.1	System Platform..... 1
1.2	Drive System Rexroth IndraDrive C - Compact Converters..... 1
1.3	Drive System Rexroth IndraDrive M - Modular System..... 3
1.4	Drive System Rexroth IndraDrive Mi..... 5
1.5	Combinations of Rexroth IndraDrive C With Rexroth IndraDrive M and Rexroth IndraDrive Mi..... 7
1.6	Basic Design of the Devices..... 8
1.6.1	General Information..... 8
1.6.2	Power Section..... 8
1.6.3	Control Section..... 9
1.7	Overview of Type Currents and Type Performances..... 9
1.7.1	General Information..... 9
1.7.2	Drive Controllers..... 9
1.7.3	Supply Units and Converters..... 10
1.8	Overview of Functions..... 11
1.8.1	Supply Units and Power Sections..... 11
1.8.2	Control Sections..... 11
1.9	Documentation..... 11
1.9.1	About This Documentation..... 11
1.9.2	Reference Documentations..... 12
	Drive Systems, System Components..... 12
	Motors..... 13
	Cables..... 13
	Firmware..... 13
1.9.3	Your Feedback..... 14
<b>2</b>	<b>Important Directions for Use ..... 15</b>
2.1	Appropriate Use ..... 15
2.1.1	Introduction..... 15
2.1.2	Areas of Use and Application..... 15
2.2	Inappropriate Use..... 16
<b>3</b>	<b>Safety Instructions for Electric Drives and Controls..... 17</b>
3.1	Safety Instructions - General Information..... 17
3.1.1	Using the Safety Instructions and Passing them on to Others..... 17
3.1.2	How to Employ the Safety Instructions..... 17
3.1.3	Explanation of Warning Symbols and Degrees of Hazard Seriousness..... 18
3.1.4	Hazards by Improper Use..... 19
3.2	Instructions with Regard to Specific Dangers..... 20
3.2.1	Protection Against Contact with Electrical Parts and Housings..... 20
3.2.2	Protection Against Electric Shock by Protective Extra-Low Voltage..... 21
3.2.3	Protection Against Dangerous Movements..... 21
3.2.4	Protection Against Magnetic and Electromagnetic Fields During Operation and Mounting..... 24

Table of Contents

	Page
3.2.5	Protection Against Contact with Hot Parts..... 24
3.2.6	Protection During Handling and Mounting..... 24
3.2.7	Battery Safety..... 25
3.2.8	Protection Against Pressurized Systems..... 25
<b>4</b>	<b>Brief Description, Usage..... 27</b>
4.1	General Information..... 27
4.2	Applications of the Drive System Rexroth IndraDrive..... 27
4.3	Mains Transformers DST and DLT..... 27
4.4	Mains Filters HNF, HNK, NFE, HNS02 and NFD..... 27
4.5	Mains Chokes HNL01 and HNL02..... 28
4.6	Supply Units HMV01 / HMV02..... 29
4.7	Drive Controllers HMS01, HMS02 and HMD01..... 29
4.8	Control Sections CSH01, CSB01, CDB01..... 29
4.9	Drive Controllers HCS02..... 30
4.10	Drive Controllers HCS03..... 30
4.11	DC Bus Resistor Unit HLB01..... 30
4.12	Braking Resistor HLR01..... 30
4.13	DC Bus Capacitor Unit HLC01..... 31
4.14	Blower Unit HAB01..... 31
4.15	Motor Filters HMF01..... 31
4.16	Accessories HAS..... 32
4.17	Housing HAC01 for Control Sections..... 32
4.18	Hall Sensor Box SHL01 (in Preparation)..... 32
<b>5</b>	<b>General Specifications of the Components..... 33</b>
5.1	Certifications..... 33
5.2	Transport and Storage..... 35
5.2.1	Transport of the Components..... 35
5.2.2	Storage of the Components..... 35
5.3	Installation Conditions..... 36
5.3.1	Ambient and Operating Conditions..... 36
5.3.2	Mounting Position..... 37
5.3.3	Compatibility with Foreign Matters..... 38
5.4	Capacity Utilization..... 38
5.5	High-Voltage Test..... 39
5.6	Control Voltage Specification (24V Supply)..... 40
<b>6</b>	<b>Project Planning of Control Voltage (24V Supply)..... 43</b>
6.1	General Information..... 43
6.2	Selection of 24V Supply..... 43
6.2.1	General Information..... 43
6.2.2	Electrical Requirements..... 44
6.3	Installation of 24V Supply..... 45
6.4	Looping Through the Control Voltage Supply..... 47



## Table of Contents

	Page
<b>7</b>	<b>Project Planning of Mains Connection..... 49</b>
7.1	General Information..... 49
7.2	Power Voltage Supply..... 49
7.3	Mains Types..... 51
7.3.1	TN-S Mains Type..... 51
7.3.2	TN-C Mains Type..... 52
7.3.3	IT Mains Type..... 52
7.3.4	TT System..... 54
7.3.5	Mains with Grounded Outer Conductor (Corner-Grounded Delta Mains)..... 54
7.4	Mains Short-Circuit Power and Mains Connected Load ..... 55
7.4.1	General Information..... 55
7.4.2	Mains Short-Circuit Power..... 55
7.4.3	Mains Connected Load..... 57
7.5	Protection Systems at the Mains Connection..... 60
7.5.1	General Information..... 60
7.5.2	Protective Grounding..... 60
	General Information..... 60
	Fusing by Protective Grounding in TN-S Mains..... 61
	Fusing by Protective Grounding in TN-C Mains..... 62
	Fusing by Protective Grounding in IT Mains (Ungrounded Mains)..... 64
	Rating of Mains Circuit Breaker..... 65
7.5.3	Connecting Equipment Grounding Conductor..... 66
	General Information..... 66
	Equipment Grounding Connection Between the Components..... 66
	Connecting Equipment Grounding Conductor to Mains..... 66
7.5.4	Residual-Current-Operated Circuit Breakers (RCD, RCCB) as Additional Fusing..... 67
	General Information..... 67
	Cause of Leakage Currents..... 67
	Possibilities of Use..... 68
	Using Residual-Current-Operated Circuit Breakers at HCS Drive Controllers..... 69
	Using Residual-Current-Operated Circuit Breakers at HMV Supply Units..... 69
7.5.5	Insulation Monitoring Devices..... 69
<b>8</b>	<b>Configuration of the Drive System..... 71</b>
8.1	General Information..... 71
8.2	Kind of Supply for Power Sections..... 71
8.2.1	General Information..... 71
8.2.2	HMV Supply Units for HMS/HMD Power Sections..... 73
	Central Supply HMV..... 73
	Parallel Operation HMV - Group Supply With DC Bus Connection HMV01, HMV02..... 75
8.2.3	Converter HCS as Supply Unit for Power Sections..... 77
	General Information..... 77
	Central Supply - HCS Supply HCS or HMS/HMD Drive Controllers..... 77
	Parallel Operation HCS - Group Supply With DC Bus Connection of the Groups..... 82
8.2.4	Third-Party Supply Units for Power Sections..... 83
	General Information..... 83

Table of Contents

	Page
8.3	Mains Connection Supply Units and Converters..... 85
8.3.1	General Information..... 85
8.3.2	Mains Connection of HMV Supply Units..... 87
	Mains Connection of HMV Supply Units..... 87
	Mains Connection of HMV01.1E Supply Units..... 88
	Mains Connection of HMV01.1R Supply Units..... 91
	Mains Connection of HMV02.1R Supply Units..... 92
8.3.3	Mains Connection for HCS Converters..... 93
	Mains Connection for Converters - Overview..... 93
	Mains Connection for HCS02 Converters..... 94
	Mains Connection for HCS03 Converters..... 96
8.4	Additional Components..... 97
8.4.1	Additional Components at the DC Bus..... 97
	General Information..... 97
	Notes on Project Planning for HLR Braking Resistors..... 98
8.4.2	Additional Components at the Motor Output..... 102
	General Information..... 102
	Motor Filters HMF01..... 102
8.5	Control Section and Firmware for Drive Controllers..... 102
8.5.1	General Information..... 102
8.5.2	Required Equipment of Control Sections With Optional Modules for Evaluating Encoder Systems.... 103
8.6	Combination with Other Rexroth Components..... 105
8.6.1	Combination with Components of the Control Range Rexroth IndraControl V..... 105
	Operator Terminals VCP..... 105
8.6.2	SERCOS Analog Converter..... 105
	General Information..... 105
	SERCOS Analog Converter..... 105
8.7	Connection Cables to Motor..... 106
8.7.1	General Information..... 106
8.7.2	Motor Cables..... 107
	General Information..... 107
	Required Cross Section..... 107
	Allowed Length of Motor Cable..... 107
	Voltage Drop on Connection to Motor Holding Brake..... 108
	Mechanical Requirements..... 108
	Third-Party Power Cables..... 108
8.7.3	Encoder Cables..... 109
8.8	Using Rexroth IndraDyn Motors..... 109
8.8.1	Rexroth IndraDyn H – Frameless Synchronous Spindle Motors..... 109
<b>9</b>	<b>Control Circuits for the Mains Connection..... 111</b>
9.1	General Information..... 111
9.2	Mains Contactor, Bb Contact..... 111
9.3	Control Circuits for Mains Connection of Rexroth IndraDrive C Drive Controllers..... 115
9.3.1	General Information..... 115

## Table of Contents

	Page	
9.3.2	Control via External Mains Contactor - HCS02 and HCS03.....	115
	General Information.....	115
	Standard Design for HCS02 and HCS03 Drive Controllers.....	116
	Design for HCS02 and HCS03 Drive Controllers with Integrated 24V Control Voltage Supply....	116
	Design for HCS02 and HCS03 Drive Controllers with Integrated 24V Control Voltage Supply and CSB01.1N-FU Control Sections.....	116
9.3.3	Control Circuits HCS02 and HCS03 with DC Bus Resistor Unit HLB01.1C or HLB01.1D.....	117
9.4	Control Circuits for Mains Connection of Rexroth IndraDrive M Supply Units.....	119
9.4.1	General Information.....	119
9.4.2	Parallel Operation HMV01.....	119
9.4.3	Deceleration in the Case of Disturbed Electronic System of Drive (DC Bus Short Circuit is Activated) .....	120
	General Information.....	120
	Control Circuits With DC Bus Short Circuit (ZKS).....	121
9.4.4	Deceleration in the Case of Emergency Stop or Mains Failure.....	128
	General Information.....	128
	Control Circuit "Position-Controlled Shutdown by the Control Unit" Without DC Bus Short Circuit (ZKS).....	128
	Control Circuit Emergency Stop Relay Without DC Bus Short Circuit (ZKS) .....	130
9.4.5	Time Behaviors When Switching HMV Supply Units ON and OFF.....	134
	Switching On.....	134
	Switching Off.....	135
<b>10</b>	<b>Electromagnetic Compatibility (EMC).....</b>	<b>137</b>
10.1	EMC Requirements.....	137
10.1.1	General Information.....	137
10.1.2	Noise Immunity in the Drive System.....	137
	Basic Structure for Noise Immunity.....	137
	Noise Immunity Limit Values.....	138
10.1.3	Noise Emission of the Drive System.....	138
	Causes of Noise Emission.....	138
	Limit Values for Line-Based Disturbances.....	139
10.2	Ensuring the EMC Requirements.....	141
10.3	Measures to Reduce Noise Emission.....	143
10.3.1	General Information.....	143
10.3.2	Shielding.....	143
10.3.3	Grounding.....	143
10.3.4	Filtering.....	143
<b>11</b>	<b>Arranging the Components in the Control Cabinet .....</b>	<b>145</b>
11.1	Dimensions and Distances.....	145
11.1.1	Main Dimensions of the System Components.....	145
	General Information.....	145
	Device Depths and Device Heights.....	145
11.1.2	Distances.....	146

Table of Contents

	Page
General Information.....	146
Distance Between the Devices.....	146
Distance to the Bottom of the Devices.....	147
Distance to the Top of the Devices.....	147
Lateral Distance at Drive System.....	149
<b>11.1.3 Boring Dimensions for the Mounting Plate.....</b>	<b>150</b>
Individually Arranged Devices.....	150
Combination of Devices of the Rexroth IndraDrive M Product Range.....	152
Combination of Drive Controllers of the Rexroth IndraDrive C Product Range.....	155
Combination of Drive Controllers of the Rexroth IndraDrive C and IndraDrive M Product Ranges....	156
<b>11.2 Arranging Components From Electrical Point of View.....</b>	<b>157</b>
<b>11.2.1 General Information.....</b>	<b>157</b>
<b>11.2.2 Performance-Dependent Arrangement .....</b>	<b>158</b>
<b>11.2.3 EMC Measures for Design and Installation.....</b>	<b>159</b>
Rules for Design of Installations With Drive Controllers in Compliance with EMC.....	159
<b>11.2.4 EMC-Optimal Installation in Facility and Control Cabinet.....</b>	<b>160</b>
General Information.....	160
Division Into Areas (Zones).....	160
Control Cabinet Mounting According to Interference Areas - Exemplary Arrangements.....	161
Design and Installation in Area A - Interference-Free Area of Control Cabinet.....	164
Design and Installation in Area B - Interference-Susceptible Area of Control Cabinet.....	165
Design and Installation in Area C - Strongly Interference-Susceptible Area of Control Cabinet....	166
<b>11.2.5 Ground Connections.....</b>	<b>167</b>
<b>11.2.6 Installing Signal Lines and Signal Cables.....</b>	<b>168</b>
<b>11.2.7 General Measures of Radio Interference Suppression for Relays, Contactors, Switches, Chokes, In-</b>	
<b>ductive Loads.....</b>	<b>169</b>
<b>12 Control Cabinet Cooling .....</b>	<b>171</b>
12.1 General Information.....	171
12.2 Passive Control Cabinet Cooling.....	172
12.2.1 Cooling via the Surface of the Control Cabinet.....	172
12.3 Active Control Cabinet Cooling.....	174
12.3.1 Ventilation of the Control Cabinet.....	174
12.4 Arrangement of Cooling Units.....	175
12.5 Multiple-Line Design of the Control Cabinet.....	178
<b>13 Connections of the Components in the Drive System.....</b>	<b>181</b>
13.1 System Connections of the Components.....	181
13.1.1 General Information.....	181
13.1.2 Position of System Connections.....	181
13.1.3 Ground Connection of Housing.....	182
13.1.4 Connection Point of Equipment Grounding Conductor and Equipment Grounding Connections....	182
General Information.....	182

## Table of Contents

	Page
Equipment Grounding Connections Between Devices.....	184
Connection to Equipment Grounding System in Control Cabinet.....	184
13.1.5 Connection to Mains Choke and Mains Filter .....	186
13.1.6 Connection of the DC Bus Connections.....	187
General Information.....	187
Maximum Allowed Line Length at DC Bus Connection.....	189
Minimum Requirements to the Connection Lines.....	190
Cable Routing to the Left.....	190
Cable Routing to the Right.....	191
13.1.7 Connection of the Control Voltage Connections.....	192
General Information.....	192
Cable Routing to the Left.....	194
Cable Routing to the Right.....	195
13.1.8 Module Bus Connection X1.....	195
13.1.9 Connection of Motor to Drive Controller X5, X6.....	195
General Information.....	195
Shield Connection with Accessory HAS02.....	196
Shield Connection Without Accessory HAS02.....	197
13.2 Overall Connection Diagrams of the System.....	200
<b>14 Accessories in the Drive System Rexroth IndraDrive.....</b>	<b>201</b>
14.1 HAS01 Basic Accessories.....	201
14.1.1 Type Code.....	201
14.1.2 Brief Description.....	201
14.1.3 Usage.....	202
14.1.4 Assignment.....	202
14.1.5 Scope of Supply.....	203
14.1.6 Mounting the Parts "Bar" and "End Piece" of the Accessories HAS01 .....	228
14.2 HAS02 Shield Connection.....	228
14.2.1 General Information.....	228
14.2.2 Type Code.....	229
14.2.3 Usage.....	229
14.2.4 Assignment of Accessory HAS02.....	229
14.2.5 Scope of Supply.....	230
14.2.6 Mounting the Accessory HAS02.....	245
General Information.....	245
HAS02.1-001 at HMS01.1N-W0054.....	246
HAS02.1-002 at HCS02.1E-W0054.....	247
HAS02.1-003 at HMS01.1N-W0210.....	248
HAS02.1-004 at HCS03.1E-W0070.....	249
HAS02.1-005 at HCS03.1E-W0100 / 150.....	250
HAS02.1-008 at HCS03.1E-W0210.....	251
HAS02.1-010 at HMS02.1N-W0028 / 54.....	251
HAS02.1-014 at HMS01.1N-W0350.....	252
14.2.7 Shield Connection of the Motor Cable via Mains Filter .....	252
General Information.....	252



## Table of Contents

	Page
HAS02.1-006 With Motor Cable and Mains Filter.....	253
HAS02.1-007 With Power Supply Cable and Mains Filter.....	254
HAS02.1-009 With Power Supply Cable and Mains Filter.....	255
14.3 HAS03 - Control Cabinet Adapter.....	256
14.3.1 Type Code.....	256
14.3.2 Usage.....	256
14.3.3 Assignment HAS03 Accessories.....	257
14.3.4 Scope of Supply.....	257
14.4 Capacitor HAS04.....	260
14.4.1 General Information.....	260
14.4.2 Type Code.....	260
14.4.3 Usage.....	260
14.4.4 Assignment.....	261
14.4.5 Scope of Supply.....	261
14.4.6 Capacitor.....	264
14.4.7 Mounting Dimensions.....	264
14.4.8 Mounting the HAS04.1-001 Accessories.....	265
14.4.9 Mounting the HAS04.1-002 Accessories.....	266
14.5 Accessories HAS05.....	268
14.5.1 Overview of Types.....	268
14.5.2 Type Code.....	269
14.5.3 HAS05.1-001, Adapter for Mains and Motor Connection.....	270
Brief Description and Usage.....	270
Technical Data.....	271
14.5.4 HAS05.1-002, Extension.....	272
Brief Description and Usage.....	272
14.5.5 HAS05.1-003, Signal Level Converter Encoder Emulation.....	273
Usage.....	273
Scope of Supply.....	273
Dimensions.....	273
Parts.....	274
14.5.6 HAS05.1-004, Adapter DC Bus Connection (Preliminary).....	276
Brief Description and Usage.....	276
Technical Data.....	280
How to Mount HAS05.1-004.....	281
14.5.7 HAS05.1-005, Signal Level Converter RS232/RS485 (Preliminary).....	285
Usage.....	285
Scope of Supply.....	285
Technical Data.....	286
Installation.....	288
14.5.8 HAS05.1-006, Adapter for Controlling Motor Holding Brake (Preliminary).....	290
Usage.....	290
Technical Data.....	291
Usage.....	293
Mounting.....	294
14.5.9 HAS05.1-007, Adapter From D-Sub to Terminal Connector (Preliminary).....	295

## Table of Contents

	Page
Usage.....	295
Technical Data.....	297
14.5.10 HAS05.1-008, Adapter for Connecting two Cables.....	302
Usage.....	302
Mounting.....	304
14.6 Fiber Optic Cable Connections.....	305
14.6.1 Overview of Types.....	305
14.6.2 Interconnection of Drive Controllers.....	306
General Information.....	306
Combination of HCS02 and HCS02.....	306
Combination of HCS02 to the Right of HMS or HMD.....	307
Combination of HCS02 to the Left of HMS or HMD.....	307
Combination of HCS03 to the Right of HMS or HMD.....	308
Combination of HCS03 to the Left of HMS or HMD.....	308
14.7 RKB0001, Extension for Module Bus Connections.....	309
14.7.1 Usage.....	309
14.7.2 Mounting.....	310
<b>15 Third-Party Motors at IndraDrive Controllers.....</b>	<b>313</b>
15.1 General Information on Third-Party Motors.....	313
15.1.1 Why Use Third-Party Motors at IndraDrive?.....	313
15.1.2 Which are the Important Directives?.....	313
15.1.3 Third-Party Motors to be Controlled.....	313
15.2 Requirements on Third-Party Motors.....	314
15.2.1 General Information.....	314
15.2.2 Voltage Load of the Third-Party Motor .....	314
15.2.3 Minimum Inductance of Third-Party Motor.....	315
15.2.4 Temperature Evaluation of Third-Party Motor.....	316
15.3 Requirements on the Encoder of the Third-Party Motor.....	316
15.3.1 Motor Encoder of Asynchronous Third-Party Motor.....	316
15.3.2 Motor Encoder of Synchronous Third-Party Motor.....	316
15.3.3 Motor Encoder Resolver - Notes on Selection.....	317
15.4 Notes on Selection and Commissioning.....	317
15.4.1 Selecting the Controller as Regards Continuous Current.....	317
15.4.2 Selecting the Connection Technique.....	317
15.4.3 Notes on Commissioning.....	318
<b>16 Calculations.....</b>	<b>319</b>
16.1 Determining the Appropriate Drive Controller.....	319
16.1.1 Introduction.....	319
16.1.2 DC Bus Continuous Power.....	319
16.1.3 DC Bus Peak Power.....	322
16.1.4 Regenerative Power.....	323
16.1.5 Reduction of Generated Power Dissipation - Additional External Capacitors at DC Bus.....	324
16.1.6 Continuous Regenerative Power.....	326

## Table of Contents

	Page
16.1.7	Peak Regenerative Power..... 329
16.1.8	Calculating the Control Factor..... 329
16.2	Calculations for the Mains Connection..... 330
16.2.1	Calculating the Mains-Side Phase Current..... 330
16.2.2	Calculating the Inrush Current..... 331
16.2.3	Mains Contactor and Fusing..... 332
16.2.4	Calculations for the Mains Harmonics..... 332
	Harmonic Load THD..... 332
	Harmonic Content / Distortion Factor k..... 332
	Power Factor $\cos\phi_1$ or DPF for Calculating the Wattless Power Load of the Mains..... 332
	Power Factor $\cos\phi$ or TPF ( $\lambda$ )..... 333
16.2.5	Mains Voltage Unbalance..... 333
16.2.6	Calculating the Allowed Continuous Power in the Common DC Bus..... 333
16.3	Determining Components in the Mains Connection..... 334
16.3.1	Determining Mains Choke HNL..... 334
16.3.2	Determining Mains Filter HNF..... 334
16.3.3	Determining the Leakage Capacitance..... 335
16.3.4	Determining the Allowed Operating Data of Mains Filters..... 336
	Reducing Allowed Operating Voltage Depending on Actual Temperature Rise Due to Harmonics.... 336
	Current Reduction in the Case of Overtemperature..... 337
16.4	Other Calculations..... 338
16.4.1	Charging the DC Bus..... 338
<b>17</b>	<b>Appendix..... 341</b>
17.1	System Elements - Product Overview, Short Designations..... 341
17.2	Capacitances Against Ground..... 342
17.2.1	General Information..... 342
17.2.2	Capacitance Data for Motors..... 342
17.2.3	Capacitance Data for Power Cables..... 344
17.3	Emitted Harmonics on Mains Current and Mains Voltage..... 344
17.3.1	General Information..... 344
17.3.2	Harmonics of Mains Current..... 345
17.3.3	Harmonics on Mains Voltage..... 349
17.4	Voltage Pulse for Test According to EN61000..... 349
17.5	Discharging of Capacitors..... 351
17.5.1	Discharging of DC Bus Capacitors..... 351
17.5.2	Discharging Device..... 351
<b>18</b>	<b>Disposal and Environmental Protection..... 353</b>
18.1	Disposal..... 353
18.1.1	Products..... 353
18.1.2	Packaging Materials..... 353
18.2	Environmental Protection..... 353
18.2.1	No Release of Hazardous Substances..... 353

## Table of Contents

	Page
18.2.2	Materials Contained in the Products..... 353
	Electronic Devices..... 353
	Motors..... 353
18.2.3	Recycling..... 354
<b>19</b>	<b>Service and Support..... 355</b>
19.1	Helpdesk..... 355
19.2	Service Hotline..... 355
19.3	Internet..... 355
19.4	Helpful Information..... 355
	<b>Index..... 357</b>





# 1 Introducing the System

## 1.1 System Platform

The following products are part of the **Rexroth IndraDrive** system platform:

Basic <b>C*B</b> single-axis/ double-axis	Advanced <b>C*H</b> single-axis	modular <b>HM*</b> single-axis/ double-axis	compact <b>HC*</b> single-axis	<b>HMV-E</b> E	<b>HMV-R</b> E / R	<b>HNF</b> <b>HNL</b> <b>HLB</b> <b>HLC</b> <b>HLR</b>	<b>MS*</b> <b>KSM</b>	<b>M**</b>
<b>Control sections</b>		<b>Power sections</b>		<b>Supply units</b>		<b>Additional components</b>	<b>Motors</b>	<b>Firmware</b>
<b>Rexroth IndraDrive System Platform</b>								

Fig. 1-1: Rexroth IndraDrive system platform

### Hierarchical Levels of Rexroth IndraDrive

The assignment of the fundamental components to the hierarchical levels system platform, type, range, line and component is illustrated in the figure below.

<b>Component</b>	W0012...70	W0070...210	W0018	W0020	W0012	01, 02, 03, 04, 05	02, 03	01
<b>Line</b>	HCS02	HCS03	HMV01 HMV02	HMS01 HMS02	HMD01	CSB	CDB	CSH
<b>Range</b>	Rexroth IndraDrive C		Rexroth IndraDrive M			Basic		Advanced
<b>Type</b>	Rexroth IndraDrive power sections					Rexroth IndraDrive control sections		
<b>System platform</b>	Rexroth IndraDrive							

Fig. 1-2: Hierarchical levels Rexroth IndraDrive C and M

<b>Component</b>	different sizes, lengths and designs	KCU01.2N-SE-SE*-025-NN-S	different lengths and codings
<b>Line</b>	KSM01	KCU01	RKHxxx
<b>Range</b>	Rexroth IndraDrive Mi		hybrid cable
<b>Type</b>	Rexroth IndraDrive distributed servo drives	Rexroth IndraDrive electronic control system	Rexroth cable
<b>System platform</b>	Rexroth IndraDrive		

Fig. 1-3: Hierarchical levels Rexroth IndraDrive Mi

### Short Designations

For an overview of the short designations, such as HMV, HCS, CSH, KCU, see Appendix of this documentation, chapter 17.1, [System Elements - Product Overview, Short Designations, page 341](#).

## 1.2 Drive System Rexroth IndraDrive C - Compact Converters

Rexroth IndraDrive C is the form of compact converters of the Rexroth IndraDrive product range.

Basic features of the product range Rexroth IndraDrive C:

- integrated power supply

Introducing the System

- integrated braking resistor (as an option, external for HCS03)
- integrated inverters
- integrated 24V control voltage supply (optional for HCS02)
- additional components:
  - DC bus resistor units
  - DC bus capacitor units
  - braking resistors

The figure below illustrates the system structure of the drive system Rexroth IndraDrive C. For the allowed combinations of components, see chapter "Configuration of the Drive System".

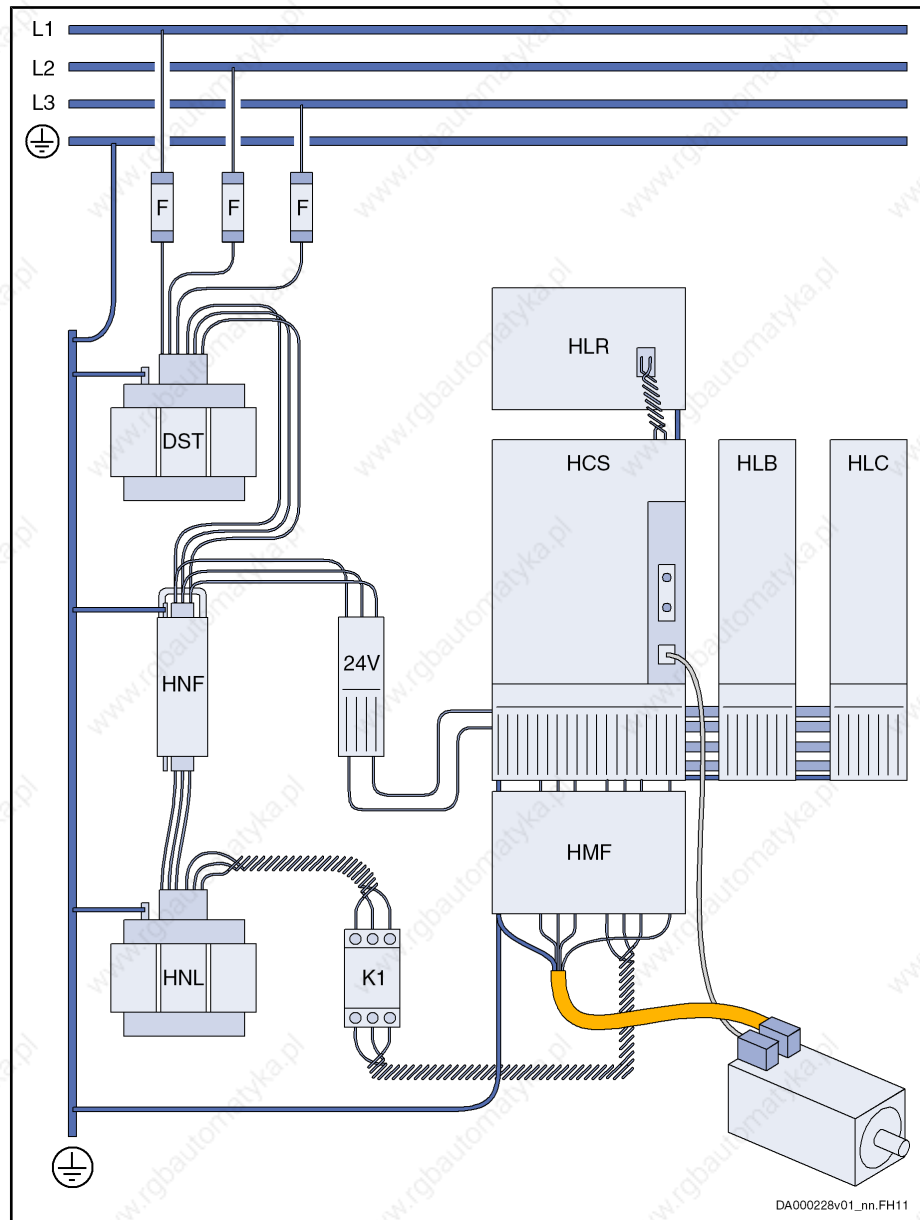

you can do without 24V power supply unit when using devices with integrated 24V power supply (HCS02.1E- or HCS03.1E-...-NNNV with control section CSB01.1N-FU)

Fig. 1-4: Drive system Rexroth IndraDrive C



---

If you use an HNK mains filter at HCS03 devices, connect the mains contactor between mains supply and mains filter.

---

## 1.3 Drive System Rexroth IndraDrive M - Modular System

Rexroth IndraDrive M is the form of a modular system of the Rexroth IndraDrive product range.

The combination of an HMV supply unit and HMS and HMD drive controllers to form a modular drive system allows operating several motors.

Basic features of the product range Rexroth IndraDrive M:

- scaleable power supply
- integrated mains contactor (except for HMV01.1R-W0120)
- modular extension of number of axis is possible
- two lines (mounting depths) of HMV and HMS available
- additional components:
  - DC bus resistor units
  - DC bus capacitor units

The figure below illustrates the system structure of the drive system Rexroth IndraDrive M. For the allowed combinations of components, see chapter "Configuration of the Drive System".

Introducing the System

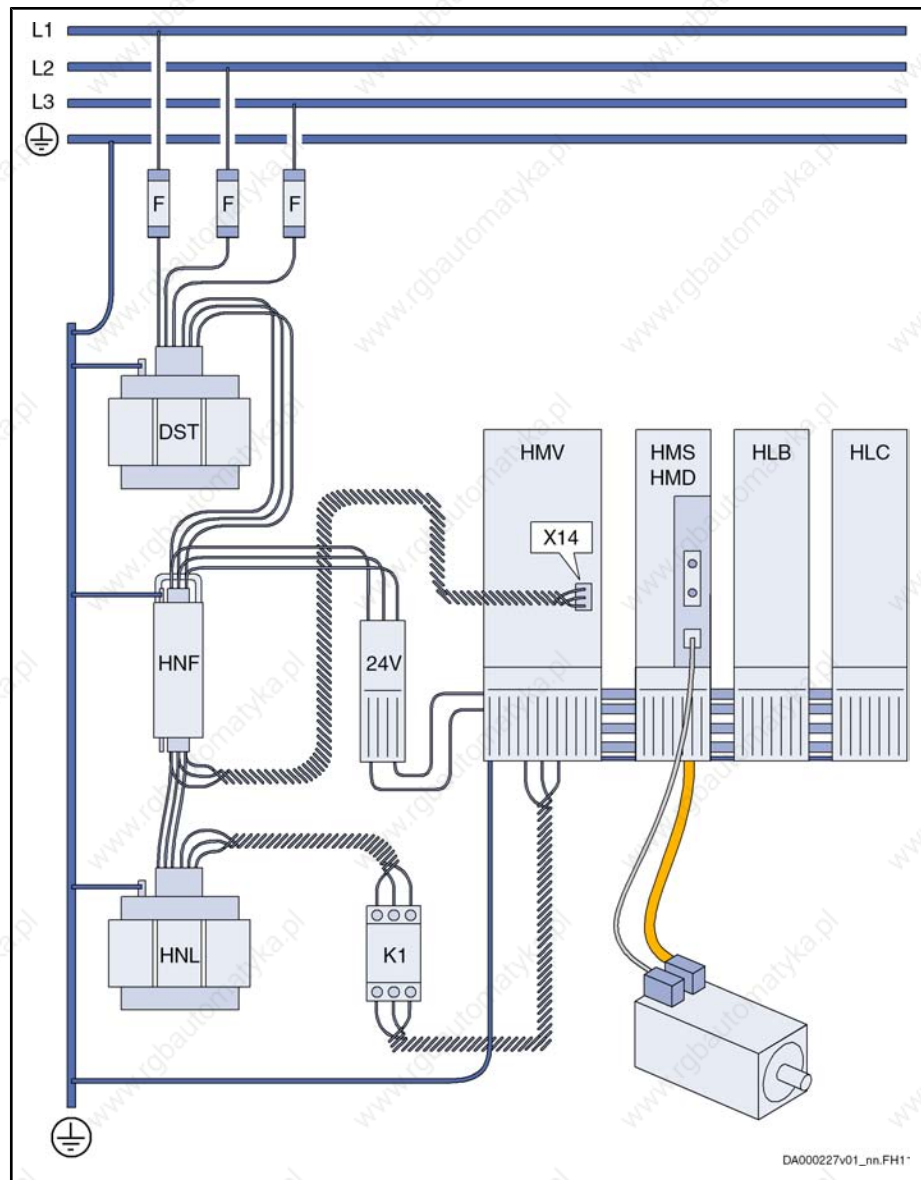

external mains contactor K1 only required for HMV01.1R-W0120  
optional mains choke (HNL) for HMV01.1E, required for HMV01.1R  
optional mains filter (HNF); depends on EMC requirements

Fig. 1-5: Drive system Rexroth IndraDrive M (line 01)

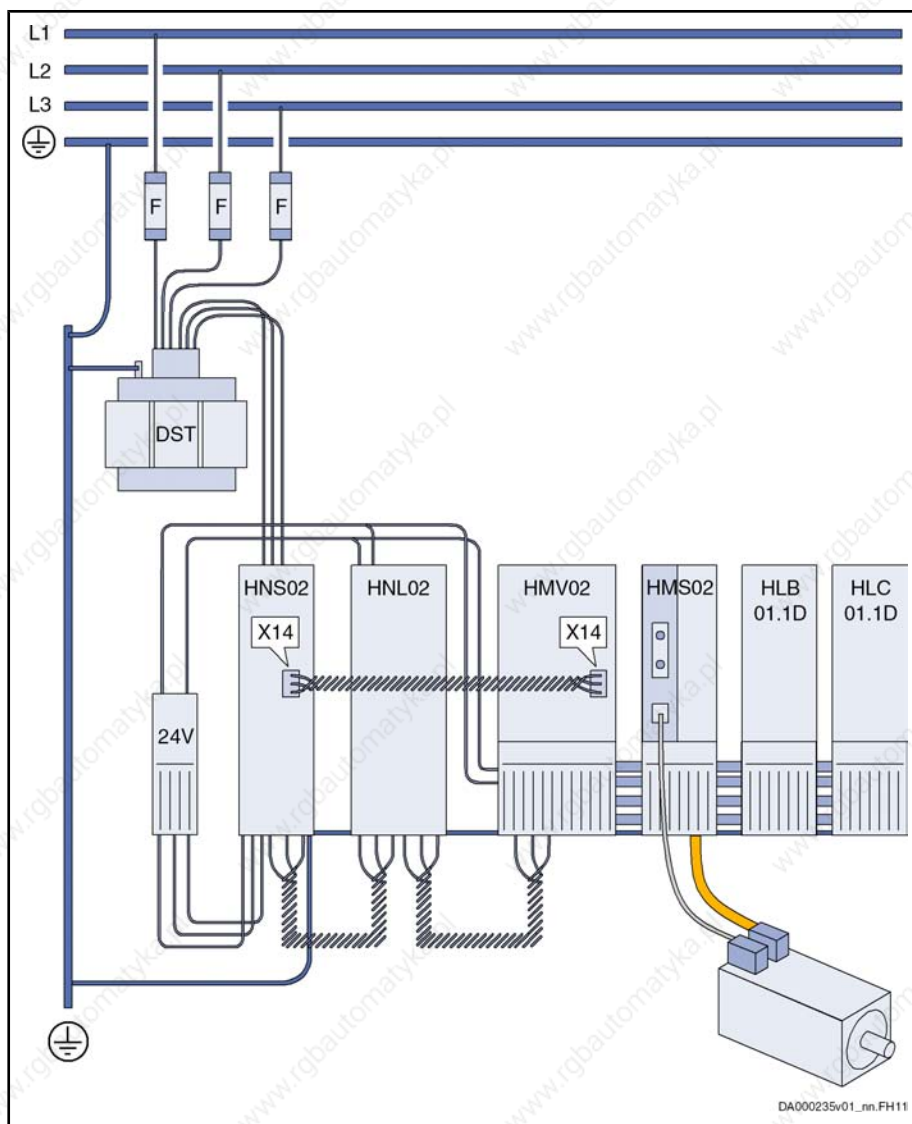

HLB01.1C optional; HLC01.1C optional

Fig. 1-6: Drive system Rexroth IndraDrive M (line 02)

## 1.4 Drive System Rexroth IndraDrive Mi

The figure below illustrates the system structure of the drive system Rexroth IndraDrive Mi with HMV supply unit. For the allowed combinations of components, see chapter "Configuration of the Drive System".



Introducing the System

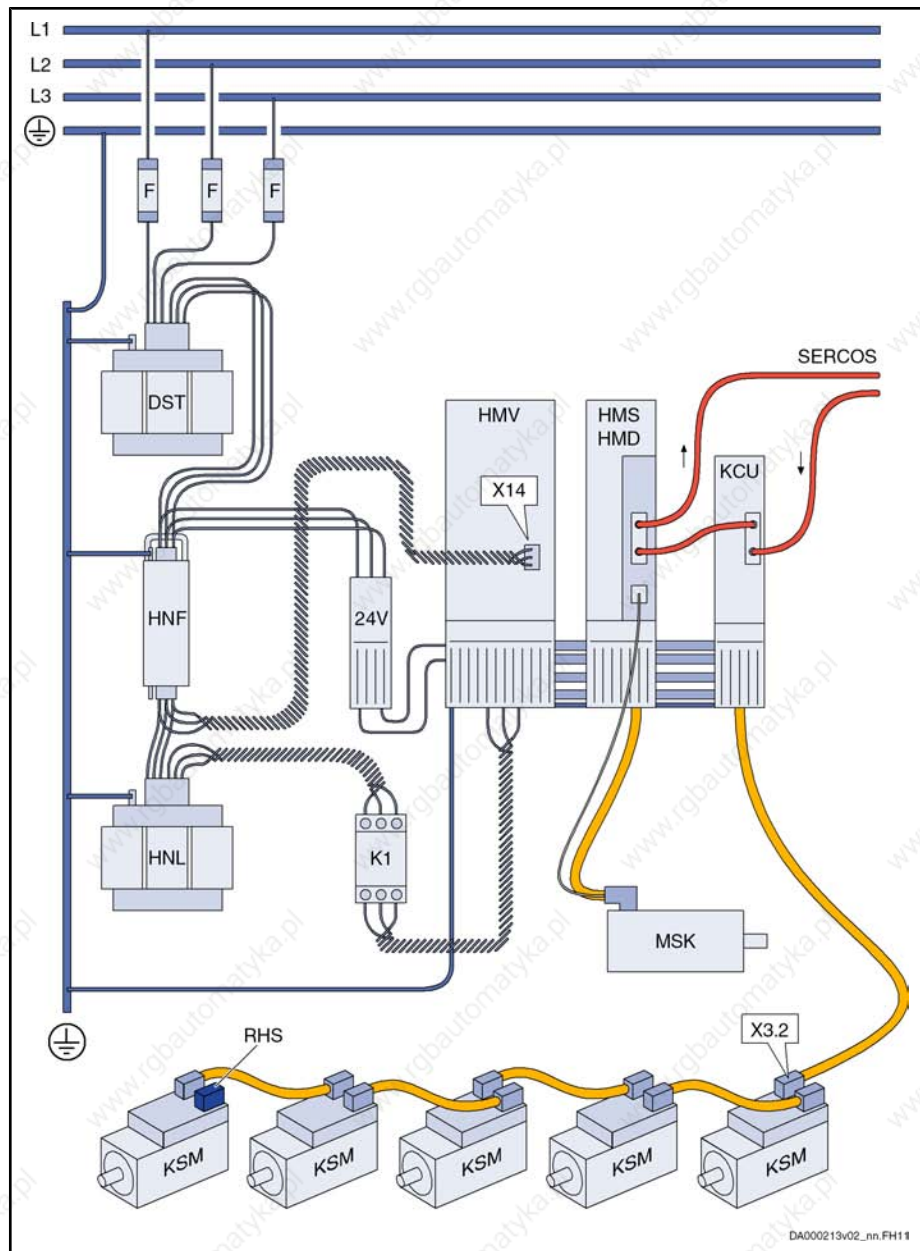

external mains contactor K1 only required for HMV01.1R-W0120  
**Fig. 1-7:** System structure Rexroth IndraDrive Mi with HMV  
 The figure below illustrates the system structure of the drive system Rexroth IndraDrive Mi with supply by an HCS converter. For the allowed combinations of components, see chapter "Configuration of the Drive System".

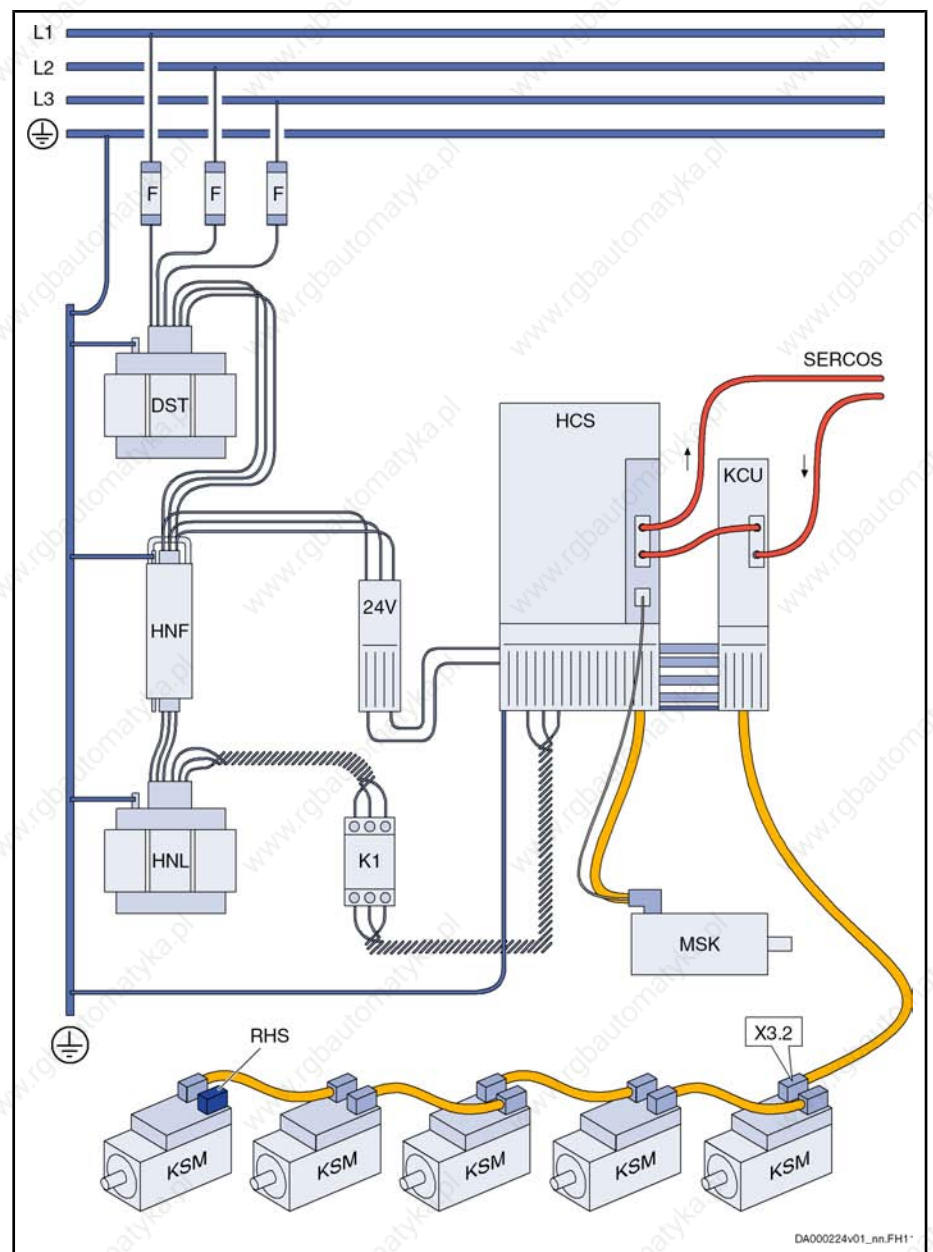

Fig. 1-8: System structure Rexroth IndraDrive Mi with HCS

## 1.5 Combinations of Rexroth IndraDrive C With Rexroth IndraDrive M and Rexroth IndraDrive Mi

On the common platform Rexroth IndraDrive, it is possible to combine the components of the product ranges IndraDrive C, Rexroth IndraDrive M and Rexroth IndraDrive Mi to form drive systems of optimum costs and performance.

To supply the product range Rexroth IndraDrive Mi (KCU01 with KSM), you can use:

- modular HMV01 and HMV02 supply units
- HCS02 and HCS03 converters

For the allowed combinations of components, see chapter "Configuration of the Drive System".

Introducing the System

## 1.6 Basic Design of the Devices

### 1.6.1 General Information

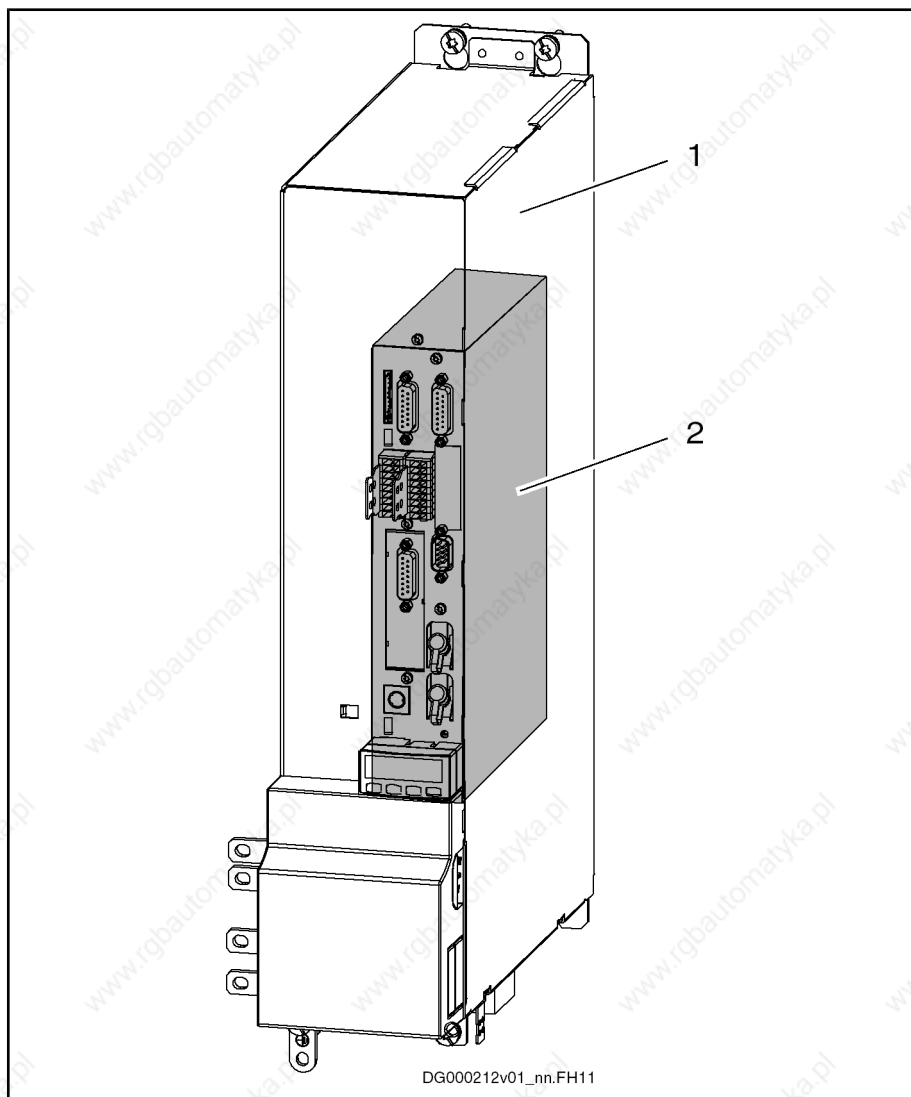

- 1 power section
- 2 control section

Fig. 1-9: Basic design of a drive controller

A drive controller consists of two essential parts:

- power section
- control section

### 1.6.2 Power Section

The power section incorporates the control section and has the following connections:

- mains voltage connection (at supply units and HCS devices)
- motor connection (with optional motor holding brake and motor temperature monitor)
- 24 V control voltage
- DC bus connection

- module bus connection for cross communication in the case of DC bus connection with other devices
- connection for external braking resistor (at HCS devices)



For detailed information on the power sections, see Project Planning Manual "Rexroth IndraDrive Supply Units and Power Sections".

### 1.6.3 Control Section

The control section is a separate component which is plugged into the power section. The control section consists of

- basic control section circuit board with interfaces
- optional modules (only for configurable control sections)

The drive controller is supplied complete with factory-installed (possibly configured) control section.



Only especially trained staff are allowed to replace control sections.



For detailed information on the control sections, see Project Planning Manual "Rexroth IndraDrive Drive Controllers Control Sections".

## 1.7 Overview of Type Currents and Type Performances

### 1.7.1 General Information

To allow you selecting appropriate drive controllers for a multitude of applications, the Rexroth IndraDrive product range includes a wide range of type currents and performances. The table below shows the fundamental data of drive controllers and supply units.



For detailed technical data, see Project Planning Manual "Rexroth IndraDrive Supply Units and Power Sections".

### 1.7.2 Drive Controllers

The order of the following table lines conforms with the peak currents of the devices.

Compact converters	Modular inverters	Type current	Contin. current $I_{out\_cont\_4k}$ [A] <sup>1)</sup>	Peak current $I_{out\_max\_4k}$ [A] <sup>1)</sup>	Nominal motor power [kW] <sup>2)</sup>
HCS02	-	W0012	4	12	1,5
-	HMD01		6,9	12	-
-	HMS01	W0020	12,1	20	-
-	HMD01		12,1	20	-
HCS02	-	W0028	11	28	4,0
-	HMS02		13	28	-
-	HMS01	W0036	21,3	36	-
-	HMD01		20	36	-

Introducing the System

Compact converters	Modular inverters	Type current	Contin. current $I_{out\_cont\_4k}$ [A] <sup>1)</sup>	Peak current $I_{out\_max\_4k}$ [A] <sup>1)</sup>	Nominal motor power [kW] <sup>2)</sup>
HCS02	-	W0054	22	54	7,5
	HMS01		35	54	-
-	HMS02		25	54	-
HCS02	-	W0070	28	70	11
HCS03	-		45	70	18,5
-	HMS01		42,4	70	-
HCS03	-	W0100	73	100	30
	HMS01	W0110	68,5	110	-
HCS03	-	W0150	95	150	45
-	HMS01		100	150	-
HCS03	-	W0210	145	210	75
-	HMS01		145	210	-
	HMS01	W0350	250	350	-

- 1) at  $f_s = 4$  kHz; without overload  
 2) for standard motor 3 AC 400 V; use of mains choke HNL01; variable torque

Fig. 1-10: Type current and type performances

### 1.7.3 Supply Units and Converters

The order of the following table lines conforms with the continuous power of the devices.

Compact converters	Modular mains supply	Type current or power	Contin. power "ON" $P_{DC\_cont}$ [kW] <sup>1)</sup>	Peak power "ON" $P_{DC\_peak}$ [kW] <sup>1)</sup>	Contin. braking power [kW]	Max. braking power [kW]
HCS02	-	E-W0028	4,2	10	0,15	10
HCS02	-	E-W0054	9,1	16	0,35	18
HCS02	-	E-W0070	13,3	19	0,5	25
-	HMV01	R-W0018	18	45	0,4	36
HCS03	-	E-W0070	25	40	opt.	opt.
-	HMV01	E-W0030	30	45	1,5	36
HCS03	-	E-W0100	43	59	opt.	opt.
HCS03	-	E-W0150	56	89	opt.	opt.
-	HMV02	R-W0015	15	37,5	0,3	33
-	HMV01	R-W0045	45	112	0,4	90
-	HMV01	R-W0065	65	162	0,4	130
-	HMV01	E-W0075	75	112	2	90
HCS03	-	E-W0210	85	124	opt.	opt.



Compact converters	Modular mains supply	Type current or power	Contin. power "ON" $P_{DC\_cont}$ [kW] <sup>1)</sup>	Peak power "ON" $P_{DC\_peak}$ [kW] <sup>1)</sup>	Contin. braking power [kW]	Max. braking power [kW]
-	HMV01	E-W0120	120	180	2,5	130
-	HMV01	R-W0120	120	180	0	0

opt. equipment to be optionally ordered  
1) with use of mains choke HNL01; at 3 AC 400 V

Fig. 1-11: Performance data of mains supply units

The data of peak power and continuous power show the maximum possible limit values.



For the actually available performance profiles, see Project Planning Manual "Rexroth IndraDrive Supply Units and Power Sections" → Chapter of the respective component → "Technical Data" → "Exemplary Data for Applications" → "Performance Profiles".

## 1.8 Overview of Functions

### 1.8.1 Supply Units and Power Sections



For an overview of the functions of supply units and power sections, see Project Planning Manual "Rexroth IndraDrive Supply Units and Power Sections" → "Functions and Electrical Connection Points" → "Overview of Functions, Power Sections and Supply Units".

### 1.8.2 Control Sections



For an overview of the functions of control sections, see Project Planning Manual "Rexroth IndraDrive Drive Controllers Control Sections" → "Rexroth IndraDrive Control Sections" → "Overview of Functions and Interfaces".

## 1.9 Documentation

### 1.9.1 About This Documentation



#### WARNING

**Personal injury and property damage caused by incorrect project planning for applications, machines and installations!**

Observe the contents of the reference documentations relevant to your drive system (see chapter [1.9.2 Reference Documentations, page 12](#)).

#### Purpose of Documentation

This documentation provides information on

- the drive system Rexroth IndraDrive
- the allowed combinations of Rexroth IndraDrive system components
- the selection of system components of the drive system Rexroth IndraDrive
- the specification applying to all components (ambient and operating conditions)
- the application description of system characteristics

Introducing the System



For detailed technical data of the individual components, see the respective Project Planning Manual. See chapter 1.9.2 Reference Documentations, page 12.

Changes in Comparison to Previous Edition

Chapter	Changes
Introducing the System	drive system Rexroth IndraDrive Mi included
Project Planning of Control Voltage	selection of 24V supply revised
Configuration of the Drive System	configuration of drive system restructured drive system Rexroth IndraDrive Mi included operation of HMS02 at HCS02 included requirements of third-party supply unit included power supply for IndraDrive Mi (KCU01 and KSM) integrated encoder systems ServoDyn D (SR, SF) included assignment Hall sensor box to optional module encoder evaluation included
Control Circuits for the Mains Connection	control circuits for mains connection expanded and restructured use without mains contactor specified HMV without integrated mains contactor included control circuits with HLB adjusted time behaviors when switching supply units ON and OFF included
Arranging the Components in the Control Cabinet	chapter "control cabinet mounting" revised lateral minimum distances HCS02 corrected
Control Cabinet Cooling	project planning of control cabinet cooling included
Connections of the Components in the Drive System	equipment grounding conductor design, cross section data and cross section reduction included fusing of branches included HMV example removed
Accessories in the Drive System	complete accessories included new: HAS05.1-004, -006, -007, -008
Calculations	data for harmonics and power factors added

Fig.1-12: Changes

## 1.9.2 Reference Documentations

### Drive Systems, System Components

Title	Kind of documentation	Document typecode <sup>1)</sup>	Part no.
Rexroth IndraDrive ...		DOK-INDRV*-...	R911...
Drive System	Project Planning Manual	SYSTEM*****-PRxx-EN-P	309636
Mi Drive Systems	Project Planning Manual	KCU+KSM*****-PRxx-EN-P	320924

Title	Kind of documentation	Document typecode <sup>1)</sup>	Part no.
Rexroth IndraDrive ...		DOK-INDRV*-...	R911...
Supply Units and Power Sections	Project Planning Manual	HMV-S-D+HCS-PRxx-EN-P	318790
Drive Controllers Control Sections	Project Planning Manual	CSH*****-PRxx-EN-P	295012
Additional Components	Project Planning Manual	ADDCOMP****-PRxx-EN-P	306140

1) In the document typecodes, "xx" is a wild card for the current edition of the documentation (example: PR01 is the first edition of a Project Planning Manual)

Fig. 1-13: Documentations – drive systems, system components

## Motors

Title	Kind of documentation	Document typecode <sup>1)</sup>	Part no.
Rexroth IndraDyn ...		DOK-MOTOR*-...	R911...
A Series Asynchronous Motors MAD/MAF	Project Planning Manual	MAD/MAF****-PRxx-EN-P	295781
H Frameless Synchronous Spindle Motors	Project Planning Manual	MBS-H*****-PRxx-EN-P	297895
L Synchronous Linear Motors	Project Planning Manual	MLF*****-PRxx-EN-P	293635
S MSK Synchronous Motors	Project Planning Manual	MSK*****-PRxx-EN-P	296289
T Synchronous Torque Motors	Project Planning Manual	MBT*****-PRxx-EN-P	298798

1) In the document typecodes, "xx" is a wild card for the current edition of the documentation (example: PR01 is the first edition of a Project Planning Manual)

Fig. 1-14: Documentations – motors

## Cables

Title	Kind of documentation	Document typecode <sup>1)</sup>	Part no.
Rexroth Connection Cables		DOK-...	R911...
Rexroth Connection Cables	Selection Data	CONNEX-CABLE*STAND-AUxx-EN-P	282688

1) In the document typecodes, "xx" is a wild card for the current edition of the documentation (example: AU03 is the third edition of the documentation "Selection Data")

Fig. 1-15: Documentations – cables

## Firmware

Title	Kind of documentation	Document typecode <sup>1)</sup>	Part no.
Rexroth IndraDrive ...		DOK-INDRV*-...	R911...
Firmware for Drive Controllers	Functional Description	MP*-02VRS**-FKxx-EN-P	299223
Firmware for Drive Controllers	Functional Description	MP*-03VRS**-FKxx-EN-P	308329
Firmware for Drive Controllers	Functional Description	MP*-04VRS**-FKxx-EN-P	315485
Firmware for Drive Controllers	Parameter Description	GEN-**VRS**-PAxx-EN-P	297317
Firmware for Drive Controllers	Troubleshooting Guide	GEN-**VRS**-WAxx-EN-P	297319
Integrated Safety Technology	Functional and Application Description	SI**-**VRS**-FKxx-EN-P	297838

Introducing the System

Title	Kind of documentation	Document typecode <sup>1)</sup>	Part no.
Rexroth IndraDrive ...		DOK-INDRV*-...	R911...
Rexroth IndraMotion MLD	Application Manual	MLD-**VRS**-AWxx-EN-P	306084
Rexroth IndraMotion MLD Library	Library Description	MLD-SYSLIB*-FKxx-EN-P	309224

1) In the document typecodes, "xx" is a wild card for the current edition of the documentation (example: PA02 is the second edition of a Parameter Description)

Fig. 1-16: Documentations – firmware

### 1.9.3 Your Feedback



Your experience is important for our improvement processes of products and documentations.

Inform us about mistakes you discovered in this documentation and changes you suggest; we would be grateful for your feedback.

Please send your remarks to:

**Address for Your Feedback**

Bosch Rexroth AG  
 Dept. BRC/EDY1  
 Bürgermeister-Dr.-Nebel-Str. 2  
 D-97816 Lohr  
 e-mail: [brcedy1-dokusupport-drives@boschrexroth.de](mailto:brcedy1-dokusupport-drives@boschrexroth.de)

## 2 Important Directions for Use

### 2.1 Appropriate Use

#### 2.1.1 Introduction

Rexroth products represent state-of-the-art developments and manufacturing. They are tested prior to delivery to ensure operating safety and reliability.



#### **Personal injury and property damage caused by incorrect use of the products!**

The products have been designed for use in the industrial environment and may only be used in the appropriate way. If they are not used in the appropriate way, situations resulting in property damage and personal injury can occur.



Rexroth as manufacturer is not liable for any damages resulting from inappropriate use. In such cases, the guarantee and the right to payment of damages resulting from inappropriate use are forfeited. The user alone carries all responsibility of the risks.

Before using Rexroth products, make sure that all the pre-requisites for an appropriate use of the products are satisfied:

- Personnel that in any way, shape or form uses our products must first read and understand the relevant safety instructions and be familiar with appropriate use.
- If the products take the form of hardware, then they must remain in their original state, in other words, no structural changes are permitted. It is not permitted to decompile software products or alter source codes.
- Do not mount damaged or faulty products or use them in operation.
- Make sure that the products have been installed in the manner described in the relevant documentation.

#### 2.1.2 Areas of Use and Application

Drive controllers made by Rexroth are designed to control electrical motors and monitor their operation.

Control and monitoring of the Drive controllers may require additional sensors and actors.



The drive controllers may only be used with the accessories and parts specified in this documentation. If a component has not been specifically named, then it may neither be mounted nor connected. The same applies to cables and lines.

Operation is only permitted in the specified configurations and combinations of components using the software and firmware as specified in the relevant Functional Descriptions.

Drive controllers have to be programmed before commissioning, making it possible for the motor to execute the specific functions of an application.

Drive controllers of the Rexroth IndraDrive line have been developed for use in single- and multi-axis drive and control tasks.

To ensure application-specific use of Drive controllers, device types of different drive power and different interfaces are available.

Typical applications include:

## Important Directions for Use

- handling and mounting systems,
- packaging and food machines,
- printing and paper processing machines and
- machine tools.

Drive controllers may only be operated under the assembly and installation conditions described in this documentation, in the specified position of normal use and under the ambient conditions as described (temperature, degree of protection, humidity, EMC, etc.).

## 2.2 Inappropriate Use

Using the Drive controllers outside of the operating conditions described in this documentation and outside of the indicated technical data and specifications is defined as "inappropriate use".

Drive controllers must not be used, if ...

- they are subject to operating conditions that do not meet the specified ambient conditions. This includes, for example, operation under water, under extreme temperature fluctuations or extremely high maximum temperatures.
- Furthermore, Drive controllers must not be used in applications which have not been expressly authorized by Rexroth. Please carefully follow the specifications outlined in the general Safety Instructions!



## 3 Safety Instructions for Electric Drives and Controls

### 3.1 Safety Instructions - General Information

#### 3.1.1 Using the Safety Instructions and Passing them on to Others

Do not attempt to install or commission this device without first reading all documentation provided with the product. Read and understand these safety instructions and all user documentation prior to working with the device. If you do not have the user documentation for the device, contact your responsible Bosch Rexroth sales representative. Ask for these documents to be sent immediately to the person or persons responsible for the safe operation of the device.

If the device is resold, rented and/or passed on to others in any other form, these safety instructions must be delivered with the device in the official language of the user's country.



**Improper use of these devices, failure to follow the safety instructions in this document or tampering with the product, including disabling of safety devices, may result in material damage, bodily harm, electric shock or even death!**

Observe the safety instructions!

---

#### 3.1.2 How to Employ the Safety Instructions

Read these instructions before initial commissioning of the equipment in order to eliminate the risk of bodily harm and/or material damage. Follow these safety instructions at all times.

- Bosch Rexroth AG is not liable for damages resulting from failure to observe the warnings provided in this documentation.
- Read the operating, maintenance and safety instructions in your language before commissioning the machine. If you find that you cannot completely understand the documentation for your product, please ask your supplier to clarify.
- Proper and correct transport, storage, assembly and installation, as well as care in operation and maintenance, are prerequisites for optimal and safe operation of this device.
- Only assign trained and qualified persons to work with electrical installations:
  - Only persons who are trained and qualified for the use and operation of the device may work on this device or within its proximity. The persons are qualified if they have sufficient knowledge of the assembly, installation and operation of the product, as well as an understanding of all warnings and precautionary measures noted in these instructions.
  - Furthermore, they must be trained, instructed and qualified to switch electrical circuits and devices on and off in accordance with technical safety regulations, to ground them and to mark them according to the requirements of safe work practices. They must have adequate safety equipment and be trained in first aid.
- Only use spare parts and accessories approved by the manufacturer.

## Safety Instructions for Electric Drives and Controls

- Follow all safety regulations and requirements for the specific application as practiced in the country of use.
- The devices have been designed for installation in industrial machinery.
- The ambient conditions given in the product documentation must be observed.
- Only use safety-relevant applications that are clearly and explicitly approved in the Project Planning Manual. If this is not the case, they are excluded. Safety-relevant are all such applications which can cause danger to persons and material damage.
- The information given in the documentation of the product with regard to the use of the delivered components contains only examples of applications and suggestions.

The machine and installation manufacturer must

- make sure that the delivered components are suited for his individual application and check the information given in this documentation with regard to the use of the components,
- make sure that his application complies with the applicable safety regulations and standards and carry out the required measures, modifications and complements.
- Commissioning of the delivered components is only permitted once it is sure that the machine or installation in which they are installed complies with the national regulations, safety specifications and standards of the application.
- Operation is only permitted if the national EMC regulations for the application are met.
- The instructions for installation in accordance with EMC requirements can be found in the section on EMC in the respective documentation (Project Planning Manuals of components and system).  
The machine or installation manufacturer is responsible for compliance with the limiting values as prescribed in the national regulations.
- Technical data, connection and installation conditions are specified in the product documentation and must be followed at all times.

*National regulations which the user must take into account*

- European countries: according to European EN standards
- United States of America (USA):
  - National Electrical Code (NEC)
  - National Electrical Manufacturers Association (NEMA), as well as local engineering regulations
  - regulations of the National Fire Protection Association (NFPA)
- Canada: Canadian Standards Association (CSA)
- Other countries:
  - International Organization for Standardization (ISO)
  - International Electrotechnical Commission (IEC)

### 3.1.3 Explanation of Warning Symbols and Degrees of Hazard Seriousness

The safety instructions describe the following degrees of hazard seriousness. The degree of hazard seriousness informs about the consequences resulting from non-compliance with the safety instructions:



## Safety Instructions for Electric Drives and Controls



Warning symbol	Signal word	Degree of hazard seriousness acc. to ANSI Z 535.4-2002
	Danger	Death or severe bodily harm will occur.
	Warning	Death or severe bodily harm may occur.
	Caution	Minor or moderate bodily harm or material damage may occur.

Fig.3-1: Hazard classification (according to ANSI Z 535)

## 3.1.4 Hazards by Improper Use

**DANGER****High electric voltage and high working current! Risk of death or severe bodily injury by electric shock!**

Observe the safety instructions!

**DANGER****Dangerous movements! Danger to life, severe bodily harm or material damage by unintentional motor movements!**

Observe the safety instructions!

**WARNING****High electric voltage because of incorrect connection! Risk of death or bodily injury by electric shock!**

Observe the safety instructions!

**WARNING****Health hazard for persons with heart pacemakers, metal implants and hearing aids in proximity to electrical equipment!**

Observe the safety instructions!

**CAUTION****Hot surfaces on device housing! Danger of injury! Danger of burns!**

Observe the safety instructions!

**CAUTION****Risk of injury by improper handling! Risk of bodily injury by bruising, shearing, cutting, hitting or improper handling of pressurized lines!**

Observe the safety instructions!

## Safety Instructions for Electric Drives and Controls

**CAUTION****Risk of injury by improper handling of batteries!**

Observe the safety instructions!

## 3.2 Instructions with Regard to Specific Dangers

### 3.2.1 Protection Against Contact with Electrical Parts and Housings



This section concerns devices and drive components with voltages of **more than 50 Volt**.

Contact with parts conducting voltages above 50 Volts can cause personal danger and electric shock. When operating electrical equipment, it is unavoidable that some parts of the devices conduct dangerous voltage.

**DANGER****High electrical voltage! Danger to life, electric shock and severe bodily injury!**

- Only those trained and qualified to work with or on electrical equipment are permitted to operate, maintain and repair this equipment.
- Follow general construction and safety regulations when working on power installations.
- Before switching on the device, the equipment grounding conductor must have been non-detachably connected to all electrical equipment in accordance with the connection diagram.
- Do not operate electrical equipment at any time, even for brief measurements or tests, if the equipment grounding conductor is not permanently connected to the mounting points of the components provided for this purpose.
- Before working with electrical parts with voltage potentials higher than 50 V, the device must be disconnected from the mains voltage or power supply unit. Provide a safeguard to prevent reconnection.
- With electrical drive and filter components, observe the following:  
Wait **30 minutes** after switching off power to allow capacitors to discharge before beginning to work. Measure the electric voltage on the capacitors before beginning to work to make sure that the equipment is safe to touch.
- Never touch the electrical connection points of a component while power is turned on. Do not remove or plug in connectors when the component has been powered.
- Install the covers and guards provided with the equipment properly before switching the device on. Before switching the equipment on, cover and safeguard live parts safely to prevent contact with those parts.
- A residual-current-operated circuit-breaker or r.c.d. cannot be used for electric drives! Indirect contact must be prevented by other means, for example, by an overcurrent protective device according to the relevant standards.
- Secure built-in devices from direct touching of electrical parts by providing an external housing, for example a control cabinet.

## Safety Instructions for Electric Drives and Controls



For electrical drive and filter components with voltages of **more than 50 volts**, observe the following additional safety instructions.

**DANGER****High housing voltage and high leakage current! Risk of death or bodily injury by electric shock!**

- Before switching on, the housings of all electrical equipment and motors must be connected or grounded with the equipment grounding conductor to the grounding points. This is also applicable before short tests.
- The equipment grounding conductor of the electrical equipment and the devices must be non-detachably and permanently connected to the power supply unit at all times. The leakage current is greater than 3.5 mA.
- Over the total length, use copper wire of a cross section of a minimum of 10 mm<sup>2</sup> for this equipment grounding connection!
- Before commissioning, also in trial runs, always attach the equipment grounding conductor or connect to the ground wire. Otherwise, high voltages may occur at the housing causing electric shock.

### 3.2.2 Protection Against Electric Shock by Protective Extra-Low Voltage

Protective extra-low voltage is used to allow connecting devices with basic insulation to extra-low voltage circuits.

All connections and terminals with voltages between 5 and 50 volts at Rexroth products are PELV systems. <sup>1)</sup> It is therefore allowed to connect devices equipped with basic insulation (such as programming devices, PCs, notebooks, display units) to these connections and terminals.

**WARNING****High electric voltage by incorrect connection! Risk of death or bodily injury by electric shock!**

If extra-low voltage circuits of devices containing voltages and circuits of more than 50 volts (e.g. the mains connection) are connected to Rexroth products, the connected extra-low voltage circuits must comply with the requirements for PELV. <sup>2)</sup>

### 3.2.3 Protection Against Dangerous Movements

Dangerous movements can be caused by faulty control of connected motors. Some common examples are:

- improper or wrong wiring of cable connections
- incorrect operation of the equipment components
- wrong input of parameters before operation
- malfunction of sensors, encoders and monitoring devices
- defective components
- software or firmware errors

Dangerous movements can occur immediately after equipment is switched on or even after an unspecified time of trouble-free operation.

1) "Protective Extra-Low Voltage"

2) "Protective Extra-Low Voltage"

## Safety Instructions for Electric Drives and Controls

The monitoring in the drive components will normally be sufficient to avoid faulty operation in the connected drives. Regarding personal safety, especially the danger of bodily harm and material damage, this alone cannot be relied upon to ensure complete safety. Until the integrated monitoring functions become effective, it must be assumed in any case that faulty drive movements will occur. The extent of faulty drive movements depends upon the type of control and the state of operation.

**DANGER****Dangerous movements! Danger to life, risk of injury, severe bodily harm or material damage!**

- Ensure personal safety by means of qualified and tested higher-level monitoring devices or measures integrated in the installation.

These measures have to be provided for by the user according to the specific conditions within the installation and a hazard and fault analysis. The safety regulations applicable for the installation have to be taken into consideration. Unintended machine motion or other malfunction is possible if safety devices are disabled, bypassed or not activated.

**To avoid accidents, bodily harm and/or material damage:**

- Keep free and clear of the machine's range of motion and moving parts. Possible measures to prevent people from accidentally entering the machine's range of motion:
  - use safety fences
  - use safety guards
  - use protective coverings
  - install light curtains or light barriers
- Fences and coverings must be strong enough to resist maximum possible momentum.
- Mount the emergency stop switch in the immediate reach of the operator. Verify that the emergency stop works before startup. Don't operate the device if the emergency stop is not working.
- Isolate the drive power connection by means of an emergency stop circuit or use a safety related starting lockout to prevent unintentional start.
- Make sure that the drives are brought to a safe standstill before accessing or entering the danger zone.
- Additionally secure vertical axes against falling or dropping after switching off the motor power by, for example:
  - mechanically securing the vertical axes,
  - adding an external braking/ arrester/ clamping mechanism or
  - ensuring sufficient equilibration of the vertical axes.
- The standard equipment motor brake or an external brake controlled directly by the drive controller are **not sufficient to guarantee personal safety!**
- Disconnect electrical power to the equipment using a master switch and secure the switch against reconnection for:
  - maintenance and repair work
  - cleaning of equipment
  - long periods of discontinued equipment use
- Prevent the operation of high-frequency, remote control and radio equipment near electronics circuits and supply leads. If the use of such devices cannot be avoided, verify the system and the installation for possible malfunctions in all possible positions of normal use before initial startup. If necessary, perform a special electromagnetic compatibility (EMC) test on the installation.



## Safety Instructions for Electric Drives and Controls

### 3.2.4 Protection Against Magnetic and Electromagnetic Fields During Operation and Mounting

Magnetic and electromagnetic fields generated by current-carrying conductors and permanent magnets in motors represent a serious personal danger to those with heart pacemakers, metal implants and hearing aids.



**WARNING**

#### Health hazard for persons with heart pacemakers, metal implants and hearing aids in proximity to electrical equipment!

- Persons with heart pacemakers and metal implants are not permitted to enter following areas:
  - Areas in which electrical equipment and parts are mounted, being operated or commissioned.
  - Areas in which parts of motors with permanent magnets are being stored, repaired or mounted.
- If it is necessary for somebody with a pacemaker to enter such an area, a doctor must be consulted prior to doing so. The noise immunity of present or future implanted heart pacemakers differs greatly so that no general rules can be given.
- Those with metal implants or metal pieces, as well as with hearing aids, must consult a doctor before they enter the areas described above. Otherwise health hazards may occur.

### 3.2.5 Protection Against Contact with Hot Parts



**CAUTION**

#### Hot surfaces at motor housings, on drive controllers or chokes! Danger of injury! Danger of burns!

- Do not touch surfaces of device housings and chokes in the proximity of heat sources! Danger of burns!
- Do not touch housing surfaces of motors! Danger of burns!
- According to the operating conditions, temperatures can be **higher than 60 °C, 140°F** during or after operation.
- Before accessing motors after having switched them off, let them cool down for a sufficiently long time. Cooling down can require **up to 140 minutes!** Roughly estimated, the time required for cooling down is five times the thermal time constant specified in the Technical Data.
- After switching drive controllers or chokes off, wait 15 minutes to allow them to cool down before touching them.
- Wear safety gloves or do not work at hot surfaces.
- For certain applications, the manufacturer of the end product, machine or installation, according to the respective safety regulations, has to take measures to avoid injuries caused by burns in the end application. These measures can be, for example: warnings, guards (shielding or barrier), technical documentation.

### 3.2.6 Protection During Handling and Mounting

In unfavorable conditions, handling and mounting certain parts and components in an improper way can cause injuries.

**CAUTION****Risk of injury by improper handling! Bodily injury by bruising, shearing, cutting, hitting!**

- Observe the general construction and safety regulations on handling and mounting.
- Use suitable devices for mounting and transport.
- Avoid jamming and bruising by appropriate measures.
- Always use suitable tools. Use special tools if specified.
- Use lifting equipment and tools in the correct manner.
- If necessary, use suitable protective equipment (for example safety goggles, safety shoes, safety gloves).
- Do not stand under hanging loads.
- Immediately clean up any spilled liquids because of the danger of skidding.

### 3.2.7 Battery Safety

Batteries consist of active chemicals enclosed in a solid housing. Therefore, improper handling can cause injury or material damage.

**CAUTION****Risk of injury by improper handling!**

- Do not attempt to reactivate low batteries by heating or other methods (risk of explosion and cauterization).
- Do not recharge the batteries as this may cause leakage or explosion.
- Do not throw batteries into open flames.
- Do not dismantle batteries.
- When replacing the battery/batteries do not damage electrical parts installed in the devices.
- Only use the battery types specified by the manufacturer.



Environmental protection and disposal! The batteries contained in the product are considered dangerous goods during land, air, and sea transport (risk of explosion) in the sense of the legal regulations. Dispose of used batteries separate from other waste. Observe the local regulations in the country of assembly.

### 3.2.8 Protection Against Pressurized Systems

According to the information given in the Project Planning Manuals, motors cooled with liquid and compressed air, as well as drive controllers, can be partially supplied with externally fed, pressurized media, such as compressed air, hydraulics oil, cooling liquids and cooling lubricating agents. Improper handling of the connected supply systems, supply lines or connections can cause injuries or material damage.

## Safety Instructions for Electric Drives and Controls

---



**CAUTION**

### **Risk of injury by improper handling of pressurized lines!**

- Do not attempt to disconnect, open or cut pressurized lines (risk of explosion).
  - Observe the respective manufacturer's operating instructions.
  - Before dismantling lines, relieve pressure and empty medium.
  - Use suitable protective equipment (for example safety goggles, safety shoes, safety gloves).
  - Immediately clean up any spilled liquids from the floor.
- 



Environmental protection and disposal! The agents used to operate the product might not be economically friendly. Dispose of ecologically harmful agents separately from other waste. Observe the local regulations in the country of assembly.

---



## 4 Brief Description, Usage

### 4.1 General Information

In terms of "Appropriate Use", cases of operation and applications not mentioned in this chapter are not allowed.



In this context, observe the chapter "[Configuration of the Drive System](#)".

### 4.2 Applications of the Drive System Rexroth IndraDrive

The digital, intelligent drive system Rexroth IndraDrive is the cost-efficient solution with a high degree of functionality for single-axis and multi-axis drive and control tasks.

The drive system Rexroth IndraDrive fulfills a large number of drive tasks in the most varied applications.

Typical applications are the industrial sectors:

- printing and paper converting
- packaging and food
- mounting and handling
- wood machining
- machine tools
- metal forming
- general automation

For these applications there are different device types of graduated performance.

### 4.3 Mains Transformers DST and DLT

**DST und DLT** transformers are used to transform mains voltages to the allowed nominal voltage of the device.

**DLT** transformers are used to

- prevent overvoltage between outer conductor and ground
- protect other loads against leakage currents

Type	Usage
DST autotransformer	adjusting voltage range in <b>grounded</b> mains
DLT isolating transformer	adjusting voltage range in <b>ungrounded</b> mains

Fig.4-1: Usage of transformers



As a matter of principle, use DLT isolating transformers at ungrounded mains.

### 4.4 Mains Filters HNF, HNK, NFE, HNS02 and NFD

Mains filters reduce radio interference and mains pollution.

Brief Description, Usage



When using HNF01, NFD03, HNS02 and HNK01 mains filters at **mains grounded via outer conductor**, use an isolating transformer between mains and mains filter.

Type	Usage
NFE01.1	interference suppression of supply units up to 230 V
NFE02.1	interference suppression of single-phase drive controllers up to 230 V
NFD03.1	interference suppression of three-phase drive controllers up to 480 V for 1–6 axes and motor cable lengths up to max. 75 m single-axis / 120 m multi-axis (HCS02.1E)
HNF01.1	interference suppression of three-phase drive controllers up to 480 V for drive systems with a high number of axes and long motor cables
HNK01.1	interference suppression of three-phase drive controllers HCS03.1E up to 500 V
HNS02	interference suppression of three-phase drive controllers up to 480 V for drive systems with a maximum of 12 axes and motor cable lengths up to a maximum of 200 m integrated switch-disconnector

Fig. 4-2: Usage of mains filters



Only operate expressly allowed components at the mentioned mains filters. Operating, for example, blowers, pumps etc. at HNF mains filters is not allowed.

## 4.5 Mains Chokes HNL01 and HNL02

(Standard) mains chokes HNL01.1E, HNL01.1R and HNL02.1R

- reduce harmonics in the mains current
- increase the allowed DC bus continuous power of certain converters
- allow operating regenerative supply units at the mains

**Current-compensated** mains chokes HNL01.1E-\*\*\*\*-S and HNL01.1R-\*\*\*\*-S

- reduce asymmetric currents (leakage currents) in the mains connection phase of the drive system.

The different types may be used **exclusively** as follows:

Type	Usage
HNL01.1R	for connection to components with regeneration to the supply mains (HNV01.1R)
HNL01.1E	for connection to components without regeneration to the supply mains (HNV01.1E, HCS02.1E; HCS03.1E)
HNL01.1*-****-S	current-compensated chokes for use with HNL01.1 mains chokes to reduce asymmetric currents (leakage currents) in the mains connection phase of the drive system (HNV01.1E, HNV01.1R; HCS02.1E; HCS03.1E)
HNL02.1R	mains chokes in housing for control cabinet mounting for connection to components with regeneration to the supply mains (HNV02.1R)

Fig. 4-3: Usage of mains chokes

## 4.6 Supply Units HMV01 / HMV02

HMV supply units supply modular HMS and HMD drive controllers.

Type	Usage
HMV01.1E	<b>infeeding</b> supplies HMS01 and HMD01 drive controllers
HMV01.1R	<b>regenerative</b> supplies HMS01 and HMD01 drive controllers
HMV02.1R	<b>regenerative</b> supplies HMS01, HMS02 and HMD01 drive controllers

Fig. 4-4: Usage of supply units

## 4.7 Drive Controllers HMS01, HMS02 and HMD01

In the modular drive system, HMS and HMD drive controllers control single and double axes.

Type	Usage
HMD01.1	<ul style="list-style-type: none"> <li>have two power outputs to operate two motors independently of each other</li> <li>are operated at HMV supply units and HCS drive controllers</li> </ul>
HMS01.1	<ul style="list-style-type: none"> <li>have a power output to operate a motor</li> <li>are operated at HMV01 supply units and HCS02 and HCS03 drive controllers</li> </ul>
HMS02.1	<ul style="list-style-type: none"> <li>have a power output to operate a motor</li> <li>are operated at HMV02 supply units and HCS02 drive controllers</li> </ul>

Fig. 4-5: Usage of HM\* drive controllers

## 4.8 Control Sections CSH01, CSB01, CDB01

CSH, CSB and CDB control sections

- allow operating HMS, HMD and HCS drive controllers
- fulfill open-loop and closed-loop control tasks with analog command value input

Type	Usage
CSH01	<b>Advanced</b> in HMS01, HMS02, HCS02 and HCS03 drive controllers
CSB01	<b>BASIC - single-axis</b> in HMS01, HMS02, HCS02 and HCS03 drive controllers
CDB01	<b>BASIC - double-axis</b> in HMD01 drive controllers in HAC01 control section housings for SERCOS analog converter

Fig. 4-6: Usage of control sections

Brief Description, Usage

## 4.9 Drive Controllers HCS02

HCS02 drive controllers control single axes.

Type	Usage
HCS02	<ul style="list-style-type: none"> <li>• have a power output to operate a motor</li> <li>• power range: 1.5 kW to 11 kW</li> </ul>

Fig.4-7: Usage of HCS02 drive controllers

## 4.10 Drive Controllers HCS03

HCS03 drive controllers control single axes.

Type	Usage
HCS03	<ul style="list-style-type: none"> <li>• have a power output to operate a motor</li> <li>• power range: 18.5 kW to 75 kW</li> </ul>

Fig.4-8: Usage of HCS03 drive controllers



In their standard design -NNNV, drive controllers HCS03 are not regenerative.

For applications where regenerative power is generated, use HCS03.1 of the -NNBV design and HLR braking resistors.

## 4.11 DC Bus Resistor Unit HLB01

DC bus resistor units HLB01

- convert generated kinetic energy into thermal energy
- increase the continuous regenerative power in the drive system
- increase the peak regenerative power in the drive system
- allow the DC bus short circuit function ("ZKS") in the drive system

Type	Usage
HLB01.1C	<p>in drive systems of the Rexroth IndraDrive C product range with a device mounting depth of 265 mm</p> <p>see also chapter "Additional Components at the DC Bus - Allowed Combinations" in the Project Planning Manual "Rexroth IndraDrive Drive System".</p>
HLB01.1D	<p>in drive systems of the Rexroth IndraDrive M product range with a device mounting depth of 322 mm</p> <p>see also chapter "Additional Components at the DC Bus - Allowed Combinations" in the Project Planning Manual "Rexroth IndraDrive Drive System".</p>

Fig.4-9: Usage of DC bus resistor units HLB

## 4.12 Braking Resistor HLR01

HLR01.1N-xxxx-Nxxx-A-007-NNNN braking resistors convert generated kinetic energy into thermal energy. For this purpose, the line covers a wide range of continuous power and energy absorption capacity.

Type	Usage
HLR01.1A	<b>Type of construction A</b> (version for device mounting): To be mounted to drive controllers of the Rexroth IndraDrive C product range. For this purpose, the drive controllers must be equipped with a brake chopper.
HLR01.1N	<b>Type of construction N</b> (version for free assembly): For free assembly in the installation, operated by drive controller of the Rexroth IndraDrive C product range. For this purpose, the drive controllers must be equipped with a brake chopper.

Fig.4-10: Usage of DC bus resistor units HLR

Versions of type of construction N:

- fixed resistor IP 20 **type A**  
cement-coated, wire-wound, tube-type fixed resistors; screwed on side walls; perforated cover; connections in terminal box with PG gland
- steel-grid fixed resistor IP 20 **type B**  
fixed resistor in steel-grid design; connection depending on type
- steel-grid fixed resistor IP 20 **type C**  
fixed resistor in steel-grid design; connection depending on type

## 4.13 DC Bus Capacitor Unit HLC01

DC bus capacitor units HLC01 store energy in the DC bus of the drive system.

Type	Usage
HLC01.1C	in drive systems of the product ranges Rexroth IndraDrive C and Rexroth IndraDrive M
HLC01.1D	in drive systems of the product ranges Rexroth IndraDrive C and Rexroth IndraDrive M

Fig.4-11: Usage of DC bus capacitor units HLC

## 4.14 Blower Unit HAB01

HAB01 blower units cool certain HMV01 and HMS01.

Type	Usage
HAB01.1	at HMS01.1N-W0350 drive controllers at HMV01.1R-W0120 supply units

Fig.4-12: Usage of HAB01 blower unit

## 4.15 Motor Filters HMF01

HMF01 motor filters

- reduce the rise of the output voltage of drive controllers
- reduce the leakage currents of the motor lines
- reduce interference voltage on the motor lines

Type	Usage
HMF01.1	at the motor output of HCS03 drive controllers

Fig.4-13: Usage of HMF01 motor filters

Brief Description, Usage

## 4.16 Accessories HAS

The HAS accessories support the operation and combination of components in the Rexroth IndraDrive system.

Description of the accessories and their usage: see chapter "14 Accessories in the Drive System Rexroth IndraDrive page 201".

## 4.17 Housing HAC01 for Control Sections

The additional component HAC01 is used to

- insert control sections in it
- supply control sections with 24V control voltage

Type	Usage
HAC01.1-002-NNN-NN	to insert CDB01 control sections in it

Fig.4-14: HAC01 type

## 4.18 Hall Sensor Box SHL01 (in Preparation)

The additional component SHL01 is used when the commutation setting of linear motors (e.g. IndraDyn L and LSF) is to be carried out, mechanical movement mustn't take place and the automatic commutation methods of the drive firmware cannot be used.

The drive firmware provides automatic commutation methods which can be used for sophisticated motion tasks.



See also Functional Description of firmware, chapter "Saturation Method" (requires  $I_{out\_max}$ ) and "Sine-Wave Method" (requires freedom of motion)

# 5 General Specifications of the Components

## 5.1 Certifications

**Declaration of Conformity** For components there are declarations of conformity which confirm that the components comply with valid EN standards and EC directives. If required, ask our sales representative for these declarations.

Designation	Standard
CE conformity regarding Low-Voltage Directive	EN61800-5-1 (IEC 61800-5-1:2003)
CE conformity regarding EMC product standard	EN61800-3 (IEC 61800-3:2004)

Fig. 5-1: Applied standards

**CE Label**

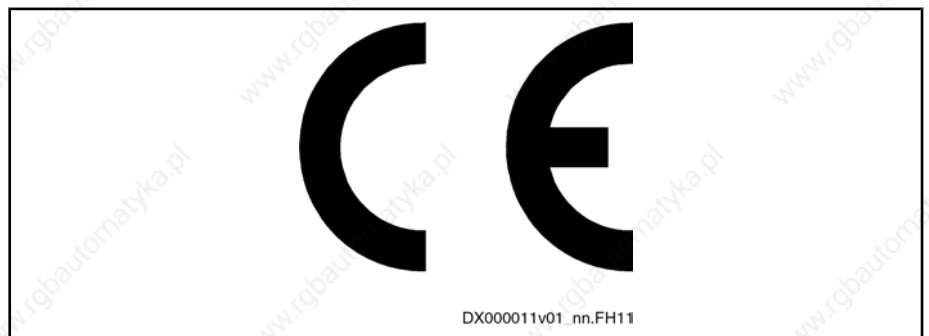

Fig. 5-2: CE label

**C-UL-US Listing**

The components are labeled:

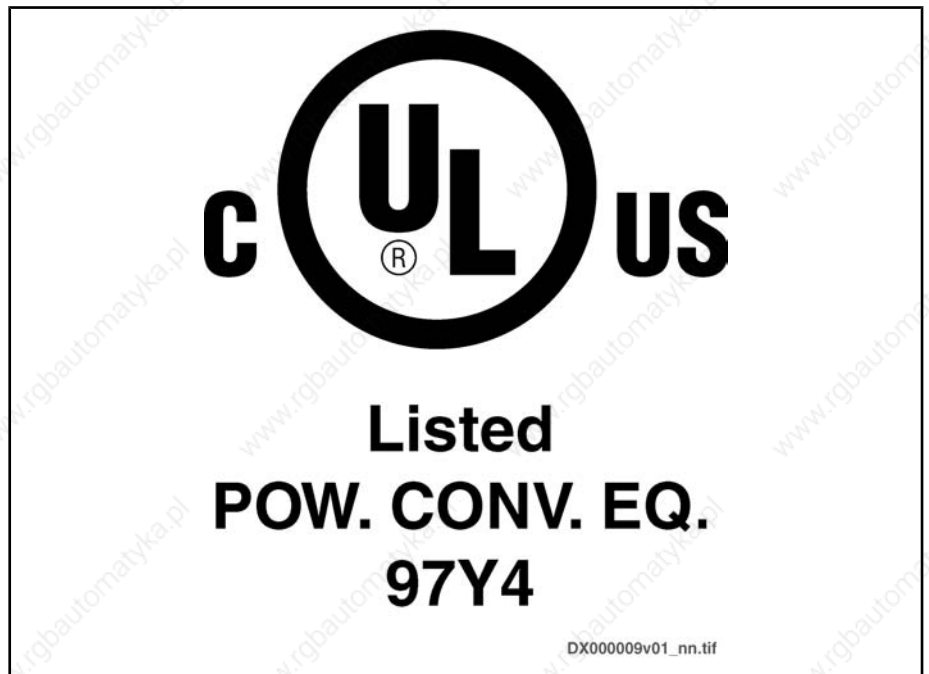

Fig. 5-3: C-UL-US label

## General Specifications of the Components

Designation	Standard
listing according to UL standard (UL)	UL 508 C
listing according to CSA standard	 See documentation of the respective component.

Fig.5-4: Applied standards

**UL ratings**

For using the component in the scope of UL, take the UL ratings of the individual components into account.



See documentation of the respective component.

In the scope of UL, it is exclusively the following components which have been approved for supplying IndraDrive components:

- HMV01.1E
- HMV01.1R
- HMV02.1R
- HCS02.1E
- HCS03.1E

**Wiring material**

In the scope of UL, use Class 1 copper wire only (or equivalent) with a minimum allowed conductor temperature of 75 °C for wiring the components.

**Allowed degree of dirt contamination**

Observe the allowed degree of dirt contamination of the components. Only use the components in environments with a maximum degree of dirt contamination 2 (see Ambient and Operating Conditions).



The components are listed by **UL** ("Underwriters Laboratories Inc.®"). You can find the evidence of certification on the internet under <http://www.ul.com> under "Certifications" by entering the file number or the "Company name: Rexroth".



See documentation of the respective component.

The **control sections** are part of the listed components.

**CCC (China Compulsory Certification)**

The CCC test symbol comprises a compulsory certification of safety and quality for certain products mentioned in the product catalog "First Catalogue of Products Subject to Compulsory Certification" and in the CNCA document "Application Scope for Compulsory Certification of Products acc. first Catalogue" and put in circulation in China. This compulsory certification has been existing since 2003.

CNCA is the Chinese authority responsible for certification directives. When a product is imported in China, the certification will be checked at the customs by means of entries in a database. For the requirement of certification three criteria are normally relevant:



## General Specifications of the Components

1. Customs tariff number (HS code) according to CNCA document "Application Scope for Compulsory Certification of Products acc. first Catalogue".
2. Scope of application according to CNCA document "Application Scope for Compulsory Certification of Products acc. first Catalogue".
3. For the IEC product standard used, the corresponding Chinese GB standard must exist.

For the Rexroth drive components described in this documentation, **certification is not required at present**, thus they are not CCC certified. Negative certifications will not be issued.

## 5.2 Transport and Storage

### 5.2.1 Transport of the Components

#### Ambient and operating conditions - Transport

Description	Symbol	Unit	Value
temperature range	$T_{a\_tran}$	°C	-25 ... 70
relative humidity		%	5 ... 95
absolute humidity		g/m <sup>3</sup>	1 ... 60
climatic category (IEC721)			2K3
moisture condensation			not allowed
icing			not allowed

Fig.5-5: Ambient and operating conditions - Transport

### 5.2.2 Storage of the Components



#### Damage to the component caused by long storage periods!

Some components contain electrolytic capacitors which may deteriorate during storage.

When storing these components for a longer period of time, operate them **once a year for at least 1 hour** with power on:

- HCS and HMV with mains voltage  $U_{LN}$
- HMS, HMD, HLC with DC bus voltage  $U_{DC}$

#### Ambient and operating conditions - Storage

Description	Symbol	Unit	Value
temperature range	$T_{a\_store}$	°C	-25 ... 55
relative humidity		%	5 ... 95
absolute humidity		g/m <sup>3</sup>	1 ... 29
climatic category (IEC721)			1K3
moisture condensation			not allowed
icing			not allowed

Fig.5-6: Ambient and operating conditions - Storage

## General Specifications of the Components

## 5.3 Installation Conditions

### 5.3.1 Ambient and Operating Conditions

The supply units and drive controllers, as well as their additional components, are designed for control cabinet mounting!



Check that the ambient conditions, in particular the control cabinet temperature, are complied with by calculating the heat levels in the control cabinet. Afterwards, make the corresponding measurements to find out that the ambient conditions have actually been complied with.

In the technical data of the individual components, the power dissipation is indicated as an important input value for calculating the heat levels.

#### Ambient and operating conditions

Description	Symbol	Unit	Value
degree of protection (IEC529)			IP20
temperature during storage			see chapter "Storage of the Components"
temperature during transport			see chapter "Transport of the Components"
allowed mounting position definition of mounting positions: see chapter 5.3.2 Mounting Position, page 37			 See documentation of the respective component.
allowed ambient temperature range	$T_{a\_work}$	°C	0 ... 40
allowed ambient temperature range during operation with reduced nominal data <sup>1)</sup>	$T_{a\_work\_red}$	°C	0 ... 55 see figure "Capacity utilization at higher ambient temperature" in chapter "Capacity Utilization"
derating at $T_{a\_work} < T_a < T_{a\_work\_red}$ <sup>2)</sup>	$f_{Ta}$	%/K	see technical data of the individual components
nominal data up to installation altitude	$h_{nenn}$	m	1000
maximum installation altitude without additional overvoltage limiter	$h_{max\_ohne}$	m	2000
maximum installation altitude <sup>3)</sup>	$h_{max}$	m	4000 see figure "Capacity utilization at higher installation altitude" in chapter "Capacity Utilization"
reduced performance data above installation altitude at $T_a < T_{a\_work\_red}$ <sup>4)</sup>	$h_{red}$	m	1000
relative humidity		%	5 ... 95
absolute humidity		g/m <sup>3</sup>	1 ... 29
climatic category (IEC721)			3K4
allowed degree of dirt contamination (EN50178)			2
allowed dust, steam			EN50178 tab. A.2
vibration sine: amplitude (peak-peak value) at 10 ... 57 Hz <sup>5)</sup>		mm	0,15 ± 15 %

General Specifications of the Components

Description	Symbol	Unit	Value
vibration sine: acceleration at 57 ... 150 Hz <sup>5)</sup>		g	1 ±15 %
vibration noise (random) frequency <sup>5)</sup>		Hz	20 ... 150
vibration noise (random) spectral acceleration density, amplitude <sup>5)</sup>		g <sup>2</sup> /Hz	0.005 ±3 dB
vibration noise (random) rms value of the total acceleration <sup>5)</sup>		g	1
shock test out of operation (EN60068-2-27), 11 ms		g	10

- 1) observe reduced performance data
  - 2) data to be derated: PDC\_cont; PBD; lout\_cont
  - 3) Install overvoltage limiter for transient overvoltage in the installation to limit the voltage to 1 kV between the outer conductors and to 2.5 kV between conductor-ground.
  - 4) see characteristic below; observe reduced performance data
  - 5) 6) according to EN 60068-2-36
- Fig.5-7: Ambient and operating conditions - Operation

### 5.3.2 Mounting Position

Only operate the components in allowed mounting positions.



For the **allowed mounting positions**, see documentation of the respective component.

#### Definition of Mounting Positions

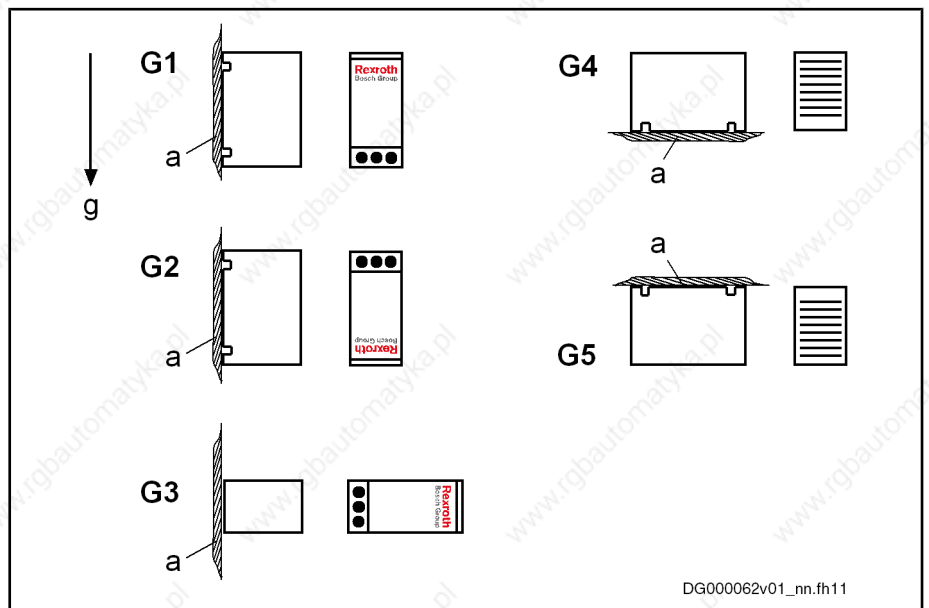

- a mounting surface
  - g direction of gravitational force
  - G1 Normal mounting position. The natural convection supports the forced cooling air current. This avoids the generation of pockets of heat in the component.
  - G2 180° to normal mounting position
  - G3 turned by 90° from vertical to horizontal mounting position
  - G4 bottom mounting; mounting surface on bottom of control cabinet
  - G5 top mounting; mounting surface at top of control cabinet
- Fig.5-8: Definition of mounting positions

## General Specifications of the Components

### 5.3.3 Compatibility with Foreign Matters

All Rexroth controls and drives have been developed and tested according to state-of-the-art technology.

As it is impossible to follow the continuing development of all materials (e.g. lubricants in machine tools) which may interact with our controls and drives, it cannot be completely ruled out that any reactions with the materials used by Bosch Rexroth might occur.

For this reason, before using the respective material you have to carry out a compatibility test for new lubricants, cleaning agents etc. and our housing/our materials.

## 5.4 Capacity Utilization

Where installation conditions differ, the following performance data are reduced in accordance with the diagrams:

**Drive controller:**

- allowed DC bus continuous power  $P_{DC\_cont}$
- braking resistor continuous power  $P_{BD}$
- continuous current  $I_{out\_cont}$

**Motor:**

- power
- continuous torque at standstill
- S1 continuous torques
- short-time service torque MKB

If differing ambient temperatures and higher installation altitudes occur simultaneously, both capacity utilization factors must be multiplied. The installation altitude must only be taken into account once, deviating ambient temperatures must be taken into account separately for motor and drive controller.



Use outside of the indicated installation conditions is not allowed, even if the performance data are additionally reduced.

**Capacity Utilization vs. Ambient Temperature**

As the ambient temperature increases, the capacity utilization of the devices is reduced according to the figure below.

General Specifications of the Components

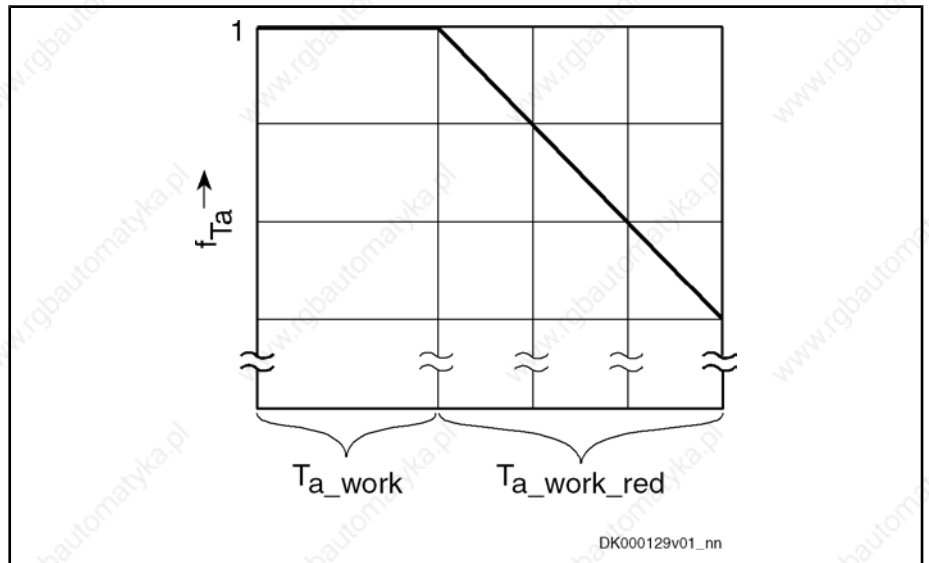

$f_{Ta}$  load factor  
 $T_{a\ work}$  ambient temperature range for operation with nominal data  
 $T_{a\ work\ red}$  ambient temperature range for operation with reduced nominal data  
 Fig.5-9: Capacity utilization at higher ambient temperature

Capacity Utilization vs. Installation Altitude

As the installation altitude increases, the capacity utilization of the devices is reduced according to the figure below.

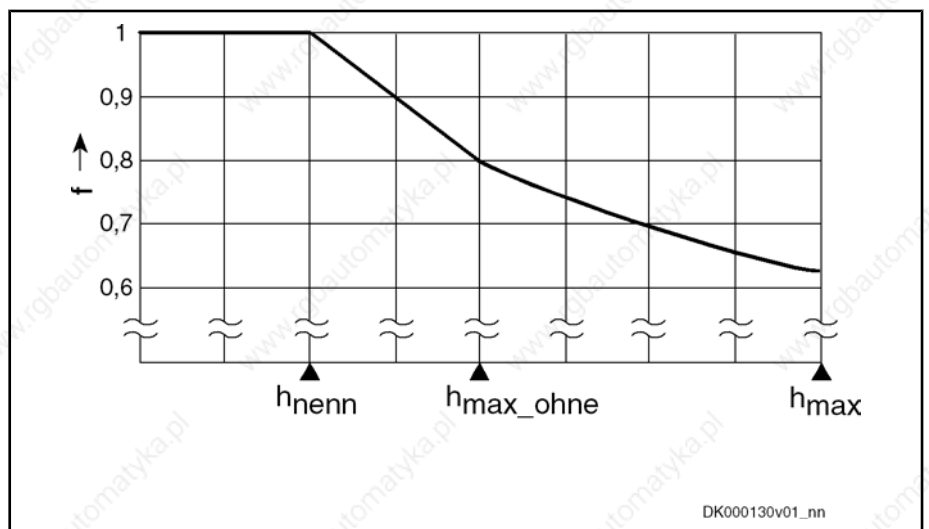

$f$  load factor  
 $h_{nenn}$  maximum installation altitude for operation with nominal data  
 $h_{max\_ohne}$  maximum installation altitude for operation with reduced nominal data without using an overvoltage limiter  
 $h_{max}$  maximum installation altitude for operation with reduced nominal data when using an overvoltage limiter  
 Fig.5-10: Capacity utilization at higher installation altitude

## 5.5 High-Voltage Test

According to standard, the components of the Rexroth IndraDrive range are tested with high voltage.

## General Specifications of the Components

Test	Test rate
high-voltage test	100% (EN61800-5-1)
high-voltage and insulation test	100% (EN61800-5-1)

Fig.5-11: Applied standards



Before making a high-voltage test for the installation in which the components are used, disconnect all connections to the components or disconnect the plug-in connections to protect the electronic components.

## 5.6 Control Voltage Specification (24V Supply)

The data in the table below generally apply to the 24V supply of the devices of the Rexroth IndraDrive range. For other data, such as power consumption and inrush currents, see the technical data of the respective device.

Description	Symbol	Unit	Value
control voltage for drive systems <b>without</b> operation of <b>motor holding brakes</b> in Rexroth motors	$U_{N3}$	V	<b>19,2 ... 28,8</b> (24 ±20%) When using supply units HMV01.1E, HMV01.1R, HMV02.1R, HLB01.1D: <b>22,8 ... 27,3</b> (24 -5%, 26 +5%)
control voltage for drive systems <b>with</b> operation of <b>motor holding brakes</b> in Rexroth motors	$U_{N3}$	V	Depending on the motor cable length, the control voltage must be within the following voltage ranges: <ul style="list-style-type: none"> <li>motor cable length &lt; 50 m: <b>22,8 ... 25,2</b> (24 ±5%)</li> <li>motor cable length &gt; 50 m: <b>24,7 ... 27,3</b> (26 ±5%)</li> </ul> Take the data of the corresponding motor holding brake into account.
external control voltage at devices of design "NNNV" (see type code HCS02, HCS03; other design: DC 24 V power supply from the DC bus or external)	$U_{N3}$	V	<b>26 ... 28,8</b> The output voltage of the internal switching power supply unit is 24 ±10% (see control voltage block diagram "int. SMPS").
max. ripple content	w	-	The amplitudes of the alternating component on $U_{N3}$ must be within the specified voltage range.
maximum allowed overvoltage	$U_{N3max}$	V	33 (max. 1 ms)

Fig.5-12: Control voltage



### Overvoltage

Overvoltage greater than 33 V has to be discharged by means of the appropriate electrical equipment of the machine or installation.

This includes:

- 24V power supply units that reduce incoming overvoltage to the allowed value.
- Overvoltage limiters at the control cabinet input that limit existing overvoltage to the allowed value. This, too, applies to long 24V lines that have been run in parallel to power cables and mains cables and can absorb overvoltage by inductive or capacitive coupling.



### Power supply units with buffer (UPS)

For HMV supply units, use 24 V supplies with buffer times of at least 100 ms (e.g. UPS), if commutation drops and short-time interruptions in the application exceed the specified values.

For the 24V supply, also take the following chapter into account: "Dimensioning the Mains Connection" in the Project Planning Manual "Rexroth IndraDrive – Drive System".



### Insulation monitoring impossible

The input 0 V is connected in conductive form with the housing potential. Insulation monitoring at +24V and 0V against housing is therefore impossible.

### Control Voltage Block Diagram

The control voltage, which is supplied via the connection for 24V supply, takes effect according to the following block diagram.

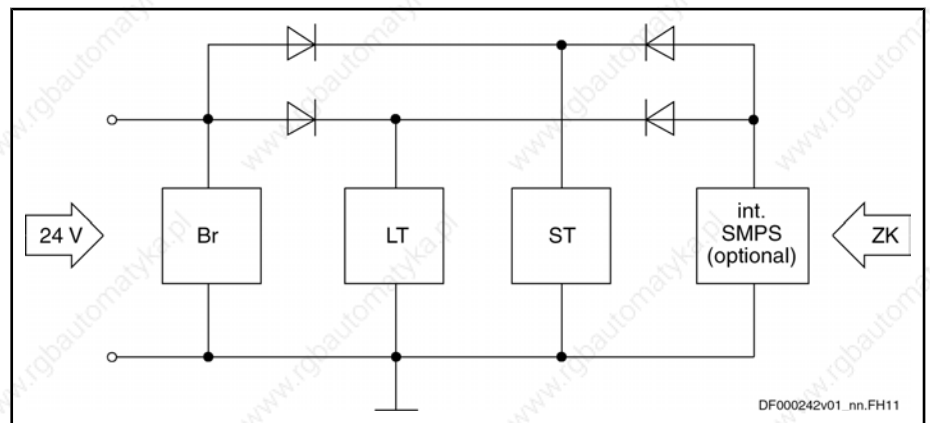

BR	circuit for brake control
LT	power section, e.g. HCS02
ST	control section, e.g. CSB01
ZK	DC bus
int. SMPS	internal switching power supply unit, for types HCS0x.1E-Wxxxx-NxxV

Fig.5-13: Block diagram of internal control voltage





## 6 Project Planning of Control Voltage (24V Supply)

### 6.1 General Information

To operate the drive system, supply the devices with control voltage. For the project planning of the 24V supply of the drive system, take the requirements of the devices used into account:

- voltage with tolerance zone position depending on line lengths and use of holding brake (see chapter "General Specifications of the Components" → "Control Voltage Specification (24V Supply)")
- power consumption of the drive controllers with control section and power section
- power consumption of other components, e.g. holding brakes
- current carrying capacity of the connections for "looping through"



For the requirements of the supply units and converters, see Project Planning Manual "Rexroth IndraDrive Supply Units and Power Sections" → Chapter of the respective device → "Technical Data" → "Basic Data" → table "Data for control voltage supply".

### 6.2 Selection of 24V Supply

#### 6.2.1 General Information

At components of the Rexroth IndraDrive range, the external 24V supply takes place via the connection X13 or via the connections 24V and 0V at the terminal block.

Via these connections, the components are supplied with 24V for

- the power section of the drive controller or supply unit
- brake control via X6
- the control section of the drive controller



The inputs/outputs of the I/O extensions MA1, MD1 and MD2 are not supplied with voltage via the control section, but have their own connections.

Take the additional power required for these connections into account.

Project Planning of Control Voltage (24V Supply)

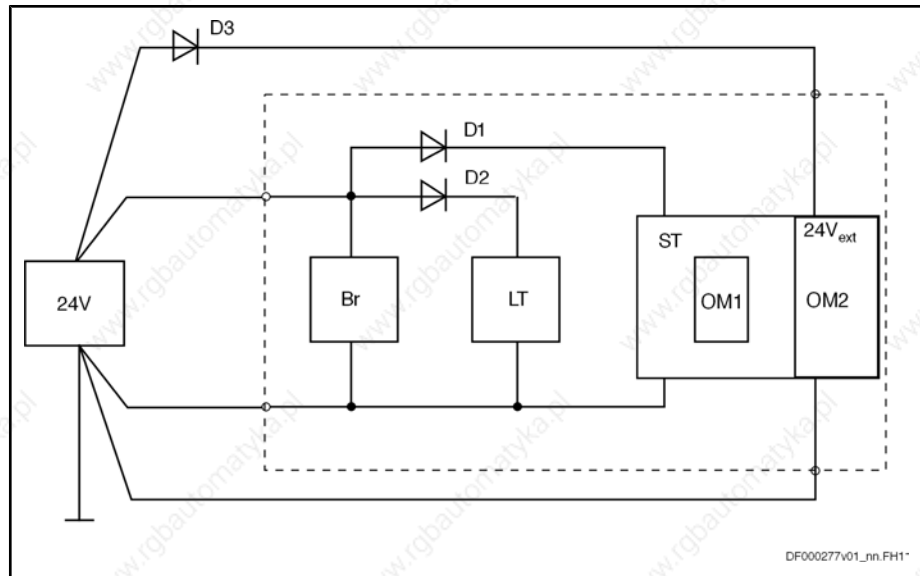

DF000277v01\_nn.FH1\*

- D1, D2 diodes, internal
  - D3 protective diode, external
  - LT power section
  - BR circuit motor holding brake
  - ST control section
  - OM1 optional modules
  - OM2 optional modules with supply voltage connection, e.g MA1, MD2
- Fig.6-1: Block diagram of 24V supply

## 6.2.2 Electrical Requirements

The following parameters contain the essential electrical requirements on the power supply unit:

- **output voltage** or range of output voltage
- **continuous power** which the power supply unit must supply during operation
- **peak current** which the power supply unit must supply when switching on

### Which Output Voltage Must the Power Supply Unit Have?

The output voltage of the power supply unit must be within the allowed input voltage  $U_{N3}$ .



See Project Planning Manual "Rexroth IndraDrive Supply Units and Power Sections" → Chapter of the respective device → "Technical Data" → "Basic Data" → "Data for control voltage supply".



### Control voltage when using motor holding brakes!

Depending on the motor cable length, a higher output voltage of the power supply unit is required for operating the motor holding brakes. Observe the data for operating motors with holding brakes in chapter "General Specifications of the Components" → "Control Voltage Specification (24V Supply)".

### Use power supply units with adjustable output voltage from 24 V to 26 V.

### Which Continuous Power Must the Power Supply Unit Supply?

The continuous power of the power supply unit must be greater than the sum of power consumptions  $P_{N3}$  of the components to be supplied.

## Project Planning of Control Voltage (24V Supply)



For the power consumption  $P_{N3}$ , see Project Planning Manual "Rexroth IndraDrive Supply Units and Power Sections" → Chapter of the respective device → "Technical Data" → "Basic Data" → "Data for control voltage supply".



For the power consumption of the control sections (basic control section circuit board or optional modules), see Project Planning Manual "Rexroth IndraDrive Drive Controllers Control Sections" → "Other Technical Data" → "Power Consumption"

If required, determine the continuous current  $I_{N3}$  for selecting the power supply unit:

$$I_{N3} = P_{N3} / U_{N3}$$

The power consumption is indicated as maximum value of the respective component and can occur at **individual components**.

In drive systems with **several components**, the occurring power consumption under statistical assumptions will be lower than the calculated one.

Experience has shown that the **typical power consumption** of drive systems is at only **approx. 70%** of the calculated maximum value.

**Which Peak Current Must the Power Supply Unit Supply?**

When switched on, the power supply unit must supply the sum of the occurring inrush currents  $I_{EIN3}$  or charges  $I_{EIN3} \times t_{EIN3Lade}$ .

When the power supply unit is switched on, the power supply unit is loaded with the charging current to the capacitors of the 24V supply input of the connected devices. An electronic circuit in each drive controller limits this charging current to the value  $I_{EIN3}$ .



For the data of the inrush current  $I_{EIN3}$  and its pulse width  $t_{EIN3Lade}$  for the individual devices, see Project Planning Manual "Rexroth IndraDrive Supply Units and Power Sections" → Chapter of the respective device → "Technical Data" → "Basic Data" → "Data for control voltage supply".

The occurring charging process  $I_{EIN3} \times t_{EIN3Lade}$  is controlled by power supply units with **integrated dynamic current limitation**, if the power supply units allow the 1.2-fold continuous current for at least 1 second. Therefore, use power supply units with integrated dynamic current limitation the continuous power of which is at least 20% above the determined sum of power consumptions  $P_{N3}$ .

## 6.3 Installation of 24V Supply

As a matter of principle, the 24V supply of the devices of the drive system Rexroth IndraDrive has to be in star-shaped form, i.e. for each group of drive controllers or third-party components it is necessary to run separate supply lines. This, too, applies to multiple-line arrangement in the case of supply from a supply unit, for example.

Project Planning of Control Voltage (24V Supply)

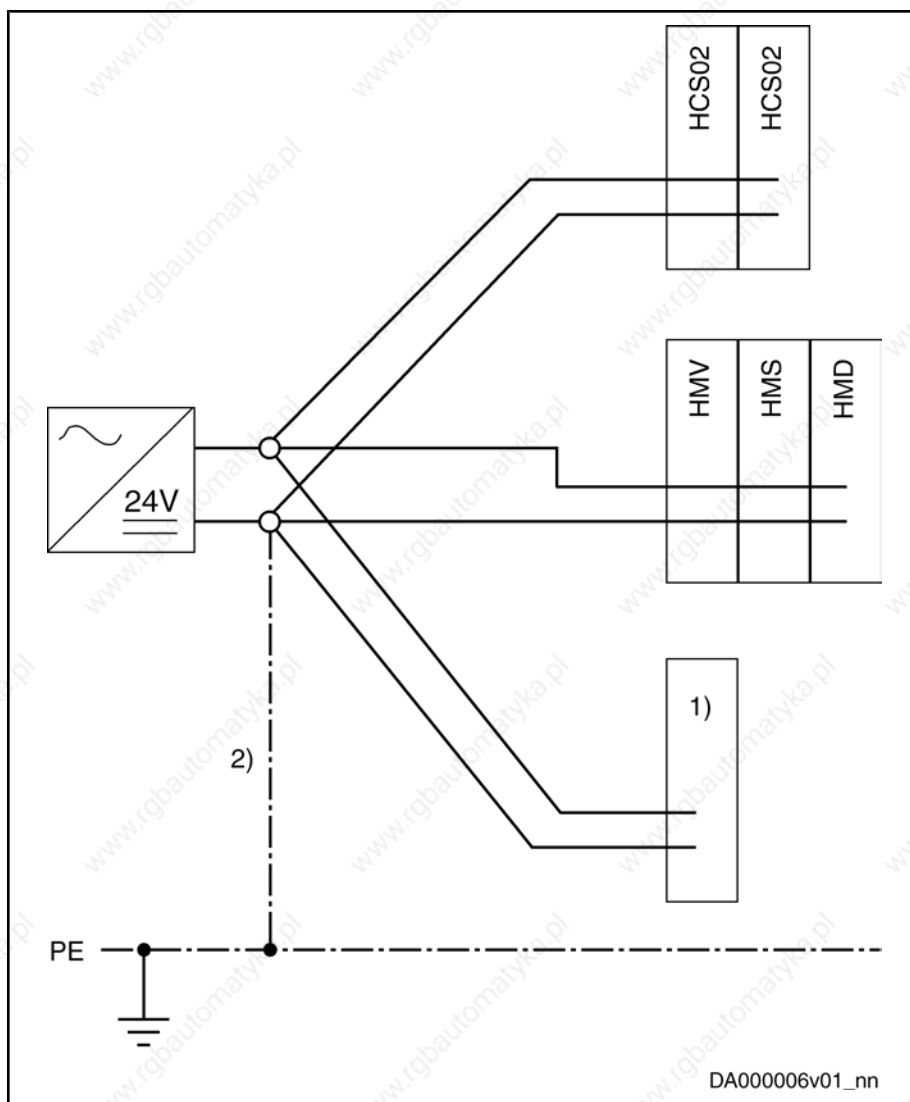

- 1) third-party component (e.g. PLC, valve etc.)
- 2) connection to central ground point (e.g. earth-circuit connector)

Fig.6-2: Installation of 24V supply



If you use several power supply units for 24 V supply:

- Interconnect the reference conductors 0 V of the individual power supply units with low impedance.
- The output voltages of the power supply units must be within the allowed voltage range.
- Switch the power supply units on and off synchronously.

**Chronological Order of 24V Supply and Mains Voltage**

Before mains voltage or DC bus voltage is applied to the devices, they have to be supplied by the 24V supply. Therefore, observe chapter 9 [Control Circuits for the Mains Connection](#), page 111.

## 6.4 Looping Through the Control Voltage Supply



### Property damage in case of error caused by too low line cross section!

Make use of the contact bars provided to loop-through and observe the current carrying capacity of the connections for 24V supply at the devices used (see Project Planning Manual "Rexroth IndraDrive Supply Units and Power Sections" → "Terminal Block, 24 V - 0V (24V Supply)" and "X13, Control Voltage (24V, 0V)").

At the drive controllers, the 24V supply is looped through via contact bars from one device to the next (for HCS02, HLB01.1C and HLC01.1C via lines at X13, see figure "Looping through the control voltage, example HCS02.1E-W0012").

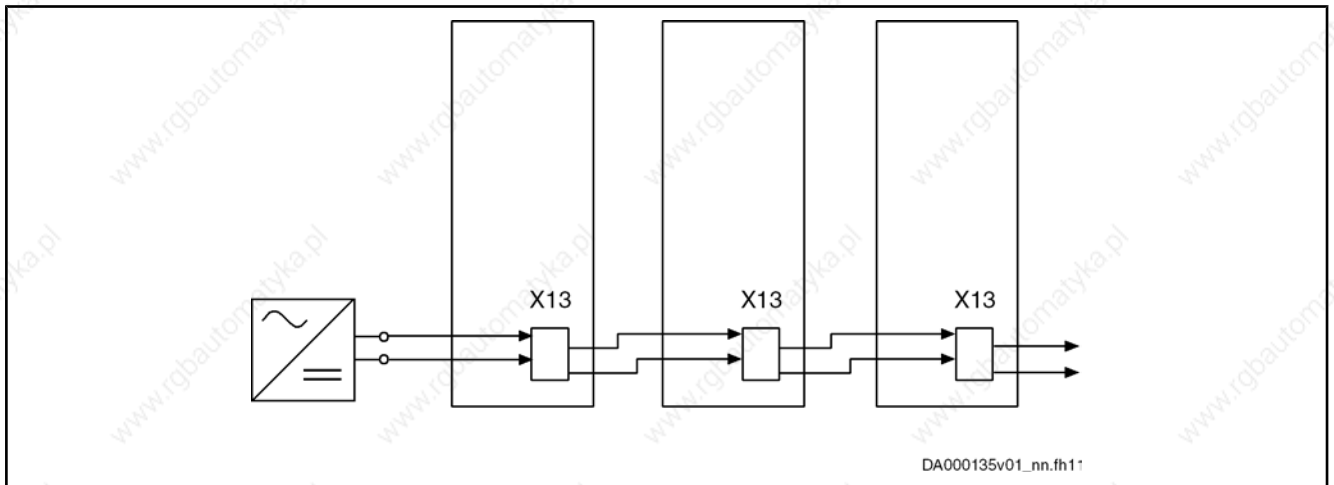

Fig. 6-3: Looping through the control voltage, example HCS02.1E-W0012

Exemplary calculation for 3 drive controllers:

$$I_D = 3 \times \frac{P_{N3}}{U_{N3}}$$

Fig. 6-4: Continuous current

The result  $I_D$  must be smaller than the specified current carrying capacity of the connection point.



### Looping through at HCS02

The current carrying capacity of X13 at HCS02 is only suited for looping through low currents. Limit the looping through to loads with low power consumption, such as HCS02.1E-W0012 with CSB01.1N-FC and additional components HLB01.1C.



### Inrush current $I_{EIN}$

When connecting the control voltage source to the connection point for 24V supply, a higher inrush current  $I_{EIN}$  will flow for the specified duration  $t_{EIN3Lade}$ .

The inrush current is increased with every additional drive controller.





## 7 Project Planning of Mains Connection

### 7.1 General Information

To supply the drive system with power, it is connected to the local supply mains via the mains connection. For the project planning of the mains connection, observe the requirements of the supply mains and of the devices used.

The essential requirements are:

- mains voltage  $U_{LN}$  (depending on mains type) with mains frequency  $f_{LN}$ , number of phases and rotary field
- mains connected load  $S_{LN}$ , mains short-circuit power  $S_{k\_min}$  and system impedance
- short-circuit current  $I_{SCCR}$ , particularly when used in the scope of C-UL
- mains circuit breaker and mains contactor
- protection systems that can be used, such as residual-current-operated circuit-breakers and insulation monitoring devices



For the requirements of the supply units and converters to the mains connection, see Project Planning Manual "Rexroth IndraDrive Supply Units and Power Sections" → Chapter of the respective device → "Technical Data" → "Basic Data" → table "Data for mains voltage supply".

### 7.2 Power Voltage Supply



#### Permanent mains connection

A permanent connection to the supply mains is required for Rexroth IndraDrive controllers.



Make sure that **all** devices participating in the mains connection are operated at the corresponding mains type in the allowed voltage range.

Description	Symbol	Unit	Value
allowed mains input voltage in <b>TN-S, TN-C, TT mains type<sup>1)</sup></b>	$U_{LN}$	V	see Project Planning Manual "Rexroth IndraDrive Supply Units and Power Sections" → Chapter of the respective device → "Technical Data" → "Basic Data" → table "Data for mains voltage supply"
allowed mains input voltage in <b>IT mains type<sup>1)</sup></b> for devices of which the minimum allowed mains input voltage includes this value	$U_{LN}$	V	
allowed mains input voltage in <b>mains grounded via outer conductor<sup>1)2)</sup></b> for devices of which the minimum allowed mains input voltage includes this value	$U_{LN}$	V	
<b>In TN-S, TN-C, TT, IT mains type and mains grounded via outer conductor:</b>			
rotary field			no rotary field condition
allowed range of mains frequency	$f_{LN}$	Hz	$(50 \dots 60) \pm 2$
maximum allowed mains frequency change	$\Delta f_{LN} / t$	Hz/s	$2\% \times f_{LN}$

Project Planning of Mains Connection

Description	Symbol	Unit	Value
maximum allowed voltage unbalance according to IEC 61000-2-4, class 3			3%
maximum allowed voltage drops on the mains voltage according to IEC 60146-1-1 – class 3			depth 40% of mains amplitude, total surface 250% × degrees (see diagram "Maximum allowed voltage drops in % of the mains voltage")
maximum allowed THD according to IEC 61000-2-4, class 3			10%
short-time interruptions			n.s., see section "Note on Project Planning Short-Time Interruptions"
maximum allowed overvoltages <sup>3)</sup> mains circuits against environment and ground		V	2000
maximum allowed overvoltages <sup>3)</sup> between the conductors of the mains connection; characteristic "Voltage Pulse" see chapter Calculations		V	1000

- 1) explanations see chapter Mains Types
- 2) for higher voltages, use isolating transformers with grounded neutral point
- 3) impulse withstand voltage 1,2/ 50 μs and 8/ 20 μs

Fig.7-1: Standard range of power voltage

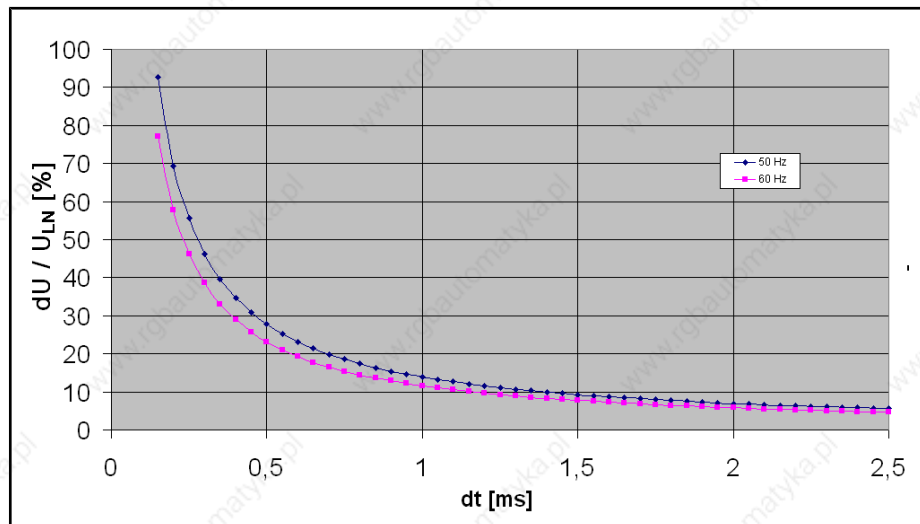

Fig.7-2: Maximum allowed voltage drops in % of the mains voltage

Note on Project Planning "Short-Time Interruptions"

The drive system is used for energy conversion and a voltage drop is a loss of available energy.

The effect of the voltage drop (energy reduction) on the process cannot be determined without detailed knowledge of the respective process. The effect is a system and rating aspect and generally will be greatest when the power demand (including the losses) of the drive system is greater than the available power.

In the case of a voltage drop on the mains, the voltage in the DC bus can be reduced. This can cause the drive system to be cut off the mains when voltage falls below certain levels and certain times are exceeded. When voltage returns, the drive system has to be reactivated in order to continue operation.

Note on Project Planning "Overvoltages"

If higher overvoltage values can occur in the application, measures for limitation of the values have to be taken in the electrical equipment of the machine or installation.



Overvoltages at the devices can occur due to

- inductive or capacitive coupling on lines
- lightning strikes

Use overvoltage limiters at the machine or installation, when the overvoltages at the devices are greater than the maximum allowed overvoltages.

Use the overvoltage limiters at long lines run through the building in parallel with power and mains cables.

Electrically place the overvoltage limiter at the control cabinet input.

## 7.3 Mains Types

### 7.3.1 TN-S Mains Type

The TN-S mains type is the usual mains type in Europe.

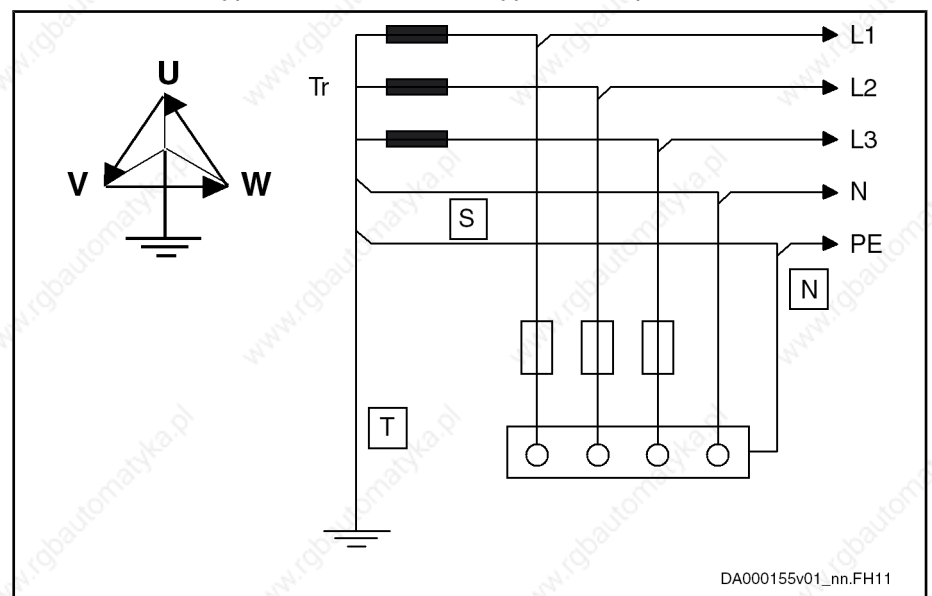

T = direct grounding of a point (station ground)

N = exposed conductive parts directly connected to station ground

S = separate neutral conductor and equipment grounding conductor in entire mains

Fig.7-3: Mains type TN-S

Project Planning of Mains Connection

### 7.3.2 TN-C Mains Type

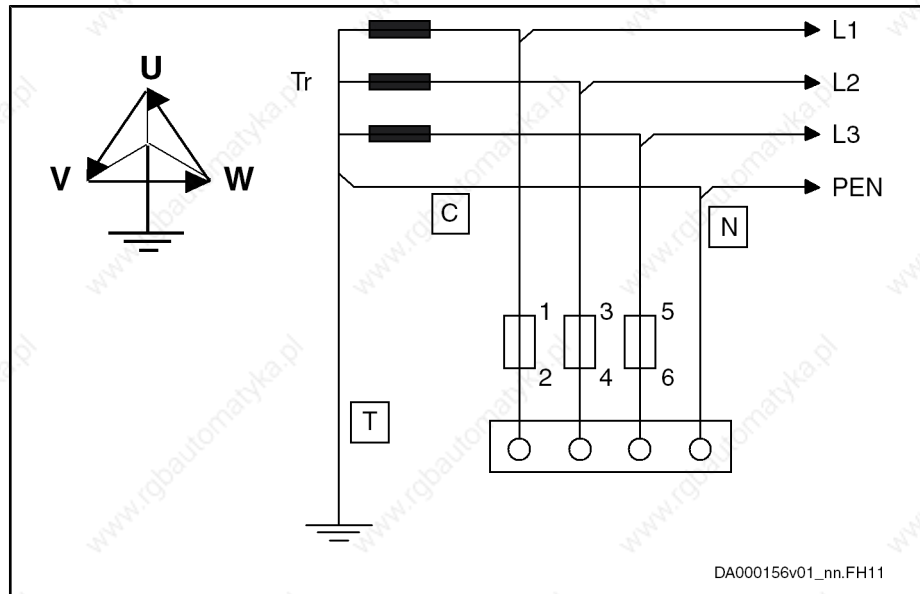

- T = direct grounding of a point (station ground)
- N = exposed conductive parts directly connected to station ground
- C = Neutral conductor and equipment grounding conductor functions in entire mains combined in a single conductor, the PEN conductor.

Fig.7-4: Mains type TN-C

### 7.3.3 IT Mains Type

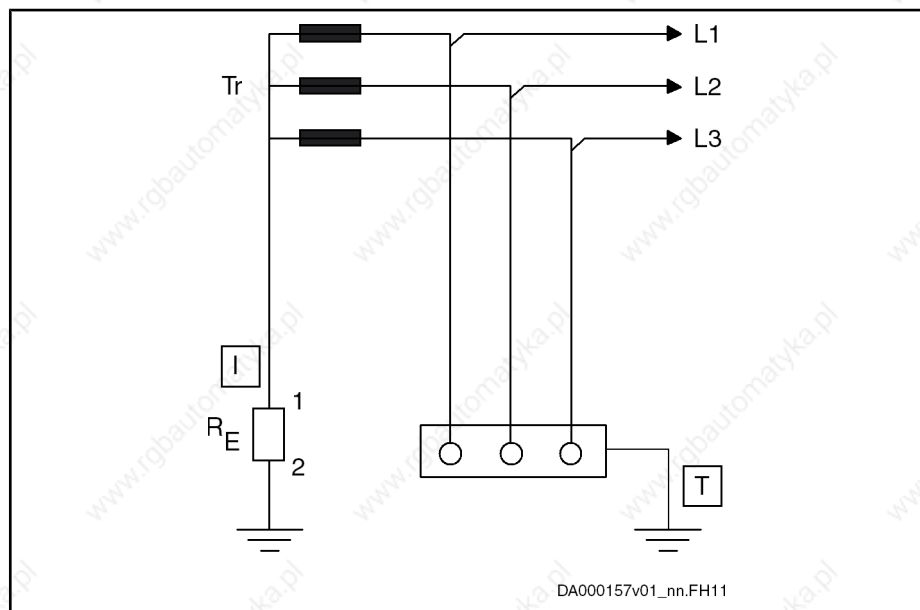

- I isolation of all active parts from ground or connection of one point to ground via an impedance RE
- T exposed conductive parts directly grounded, independent of grounding of current source (station ground)

Fig.7-5: Mains type IT

## Notes on Project Planning

**Damage to the devices by voltage arcing!**

For applications with static charging (e.g. printing, packaging) and operation at IT mains type, use an **isolating transformer** with  $U_K \leq 2.5\%$ .

**Voltage increase in the case of ground fault!**

In case of the error "ground fault" in the IT mains type, higher voltages against ground (device housing) than in error-free operation affect the device.

For operation at the IT mains type, the drive system including mains filter and mains choke should be galvanically decoupled from the mains via an **isolating transformer**.

In this was, the ground fault detection or monitoring can remain effective in the installation.

When operating IndraDrive C (HCS) drive systems in other applications **without isolating transformer** at the IT mains type,

- observe the allowed mains voltage  $U_{LN}$  at the IT mains type of the corresponding devices
- observe the allowed switching frequency  $f_s$ ; see note below
- check whether the ground fault detection of the mains does not trigger accidentally
- check whether the interference suppression (that is only activated via the parasitic mains capacitances of the ungrounded mains) is still sufficient to comply with the required limit values

The EMC requirements are only complied with by further measures (special mains filters, among other things)!

**Allowed switching frequency  $f_s$** 

Operating HCS03 converters at IT mains types without isolating transformer is only allowed with switching frequencies  $f_s \leq 8$  kHz.

See also Parameter Description "P-0-0001, Switching frequency of the power output stage".

Project Planning of Mains Connection

7.3.4 TT System

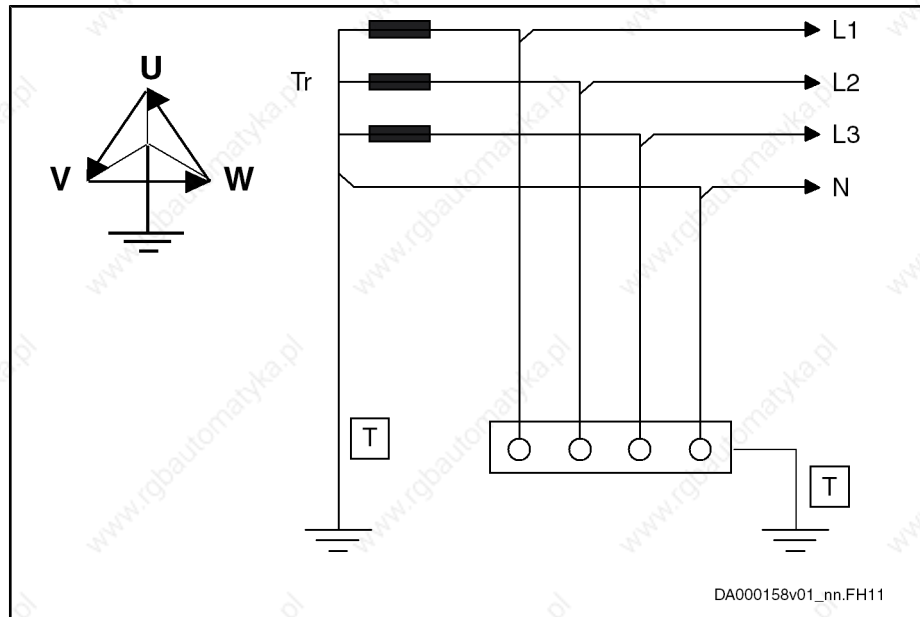

T = direct grounding of a point (station ground)  
 T = exposed conductive parts directly grounded, independent of grounding of current source (station ground)

Fig.7-6: Mains system TT

The EMC requirements are only complied with by specific measures (special mains filters, among other things).

7.3.5 Mains with Grounded Outer Conductor (Corner-Grounded Delta Mains)

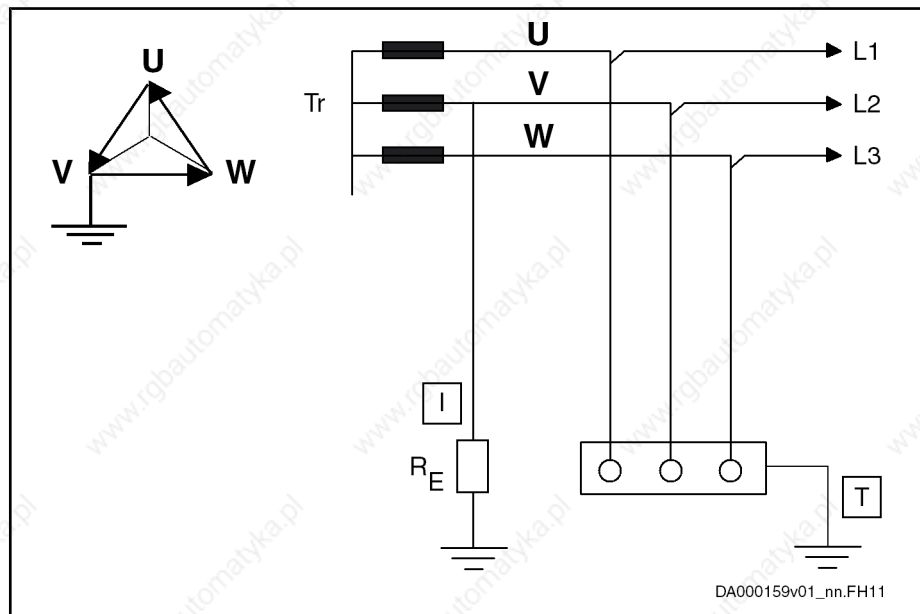

I = isolation of all active parts from ground, connection of one phase - generally phase V - to ground or via an impedance  
 T = exposed conductive parts directly grounded, independent of grounding of current source (station ground)

Fig.7-7: Mains with grounded outer conductor

Notes on Project Planning

The EMC requirements are only complied with by specific measures (special mains filters, among other things).



**Mains filters HNF01, NFD at mains grounded via outer conductor**

HNF01.1 or NFD03.1 mains filters are not suited for operation on mains grounded via outer conductor. Use isolating transformers.

Allowed mains connection voltage: see technical data of the respective device

## 7.4 Mains Short-Circuit Power and Mains Connected Load

### 7.4.1 General Information

Apart from the mains connected load, observe the following corridor of the mains short-circuit power for the mains connection:

- **Minimum required mains short-circuit power** (mains connected load) for interference-free operation

The smaller the mains short-circuit power, the greater the mains pollution due to the load current with harmonics on the supply voltage of the device. This can disturb both the device and other devices at the same mains node.

Minimum mains short-circuit power is required to limit mains pollution and to have sufficiently high voltage for realizing the drive performance.

- **Maximum allowed mains short-circuit power** (for device protection)

The higher the mains short-circuit power, the greater the short-circuit currents occurring in the case of error.

Use mains chokes to limit the short-circuit currents in the case of high mains short-circuit power  $S_k$ . See also note on "UL requirement  $I_{SCCR}$ ".



For comments on the short designations used, see chapter [16.2 Calculations for the Mains Connection, page 330](#).

### 7.4.2 Mains Short-Circuit Power

Mains short-circuit power:

Power at nominal voltage  $U_N$  between the phases and the maximum mains short-circuit current  $I_k$  at the connection point:

$$S_k = \sqrt{3} U_N \times I_k$$

$S_k$  short-circuit power of the mains

$I_k$  short-circuit current

$U_N$  mains voltage

*Fig. 7-8: Mains short-circuit power*



For the mains short circuit power of the point of supply, ask your local power supply company.

$I_k$  results in the case of a short circuit at the point of power supply connection. It is calculated as follows:



Project Planning of Mains Connection

$$I_k = \frac{U_N}{\sqrt{3}X_k}$$

$X_k$  system impedance  
 $U_N$  mains voltage  
 Fig.7-9: Mains short-circuit current



**UL requirement  $I_{SCCR}$**

Devices with C-UL listing are operated at mains nodes with a symmetrical short-circuit current smaller than the indicated value  $I_{SCCR}$ . If necessary, use mains chokes to increase the system impedance and reduce the short-circuit current.

$$I_{SCCR} = I_k$$

**Mains Classes According to Short-Circuit Power**

We basically distinguish the following mains (graded according to mains short-circuit power and system impedance):

Classification	$S_k$ MVA	$U_N = 400\text{ V}$		$U_N = 480\text{ V}$	
		$X_k$ mOhm	$L_k$ μH	$X_k$ mOhm	$L_k$ μH
		<b>1</b> rigid mains	200	0,80	2,55
	150	1,07	3,40	1,54	4,89
	100	1,60	5,09	2,30	7,33
	50	3,20	10,19	4,61	14,67
<b>2</b> semi-rigid mains	40	4,00	12,73	5,76	18,33
	30	5,33	16,98	7,68	24,45
	<b>20</b>	<b>8,00</b>	<b>25,46</b>	11,52	36,67
	15	10,67	33,95	15,36	48,89
	10	16,00	50,93	23,04	73,34
	5	32,00	101,86	46,08	146,68
	4	40,00	127,32	57,60	183,35
<b>3</b> non-rigid mains	3	53,33	169,77	76,80	244,46
	2	80,00	254,65	115,20	366,69
	1	160,00	509,30	230,40	733,39
	0,6	266,67	848,83	384,00	1222,31

$S_k$  short-circuit power of the mains  
 $X_k$  system impedance  
 $L_k$  inductance of mains phase

Fig.7-10: Mains classified according to mains short circuit power and mains internal resistance

**Minimum inductance**

The specified minimum inductances protect the drive controllers (especially the DC bus capacitances) during operation at mains with low impedance and high mains short-circuit power.

Use mains chokes at mains with  $L_k < L_{min}$ .

**Example:**

$U_N = 400 \text{ V}$ ;  $S_K > 20 \text{ MVA}$ ;  $L_k = 25.46 \mu\text{H}$

Data  $L_{min}$  of drive controller in technical data:  $40 \mu\text{H}$

$L_k < L_{min}$ : use of assigned mains choke is required.

### 7.4.3 Mains Connected Load

The apparent power with which the mains is loaded by the drive system is significantly determined by the power factor ( $\cos\phi$  with sinusoidal mains current or TPF with non-sinusoidal mains current). The load of the mains with harmonics is taken into account.

The mains connected load is calculated as follows from the projected power in the DC bus:

$$S_{LN} = \frac{P_{DC}}{TPF}$$

$S_{LN}$  mains connected load [VA]

$P_{DC}$  DC bus continuous power [W]

TPF Total Power Factor  $\lambda$

*Fig. 7-11: Calculating the mains connected load*

For the data of the **TPF**, see Project Planning Manual "Rexroth IndraDrive Supply Units and Power Sections" → Chapter of the respective device → "Technical Data" → "Basic Data" → table "Data for mains voltage supply".

**Maximum Allowed Connected Load at the Mains**

The maximum allowed connected load at the mains depends on the allowed distortion of the mains voltage due to the load current with harmonics (mains pollution). The distortion is described by the total harmonic distortion (THD) of the mains current (see chapter [16 Calculations](#), [page 319](#)).

In order to limit the distortion of the mains voltage, take the mains short-circuit ratio  $R_{SC}$  (ratio of the source) into account:

$$R_{sc} = \frac{I_k}{I_{1N}} = \frac{S_k}{S_A} = \frac{S_k}{\sum S_{LN}}$$

$I_k$  mains short-circuit current

$I_{1N}$  fundamental wave of nominal current of all loads at connection point

$S_k$  mains short-circuit power

$S_A$  connected load of all electric loads at connection point (apparent power of fundamental wave)

$\sum S_{LN}$  sum of mains connected loads of the supply units or converters

*Fig. 7-12: Mains short-circuit ratio*

**Measures for Compliance with Allowed THD or Distortion Factor**

For **public** mains we distinguish:

- Mains connections under 16 A:

Project Planning of Mains Connection

With an  $R_{SC} \geq 1000$ , there normally isn't any restriction of the allowed mains current distortion (according to EN 61000-3-2).

- Mains connections over 16 A:

The power supply company determines the restrictions. Unless there are other values available, the following data can be considered as guide values.

$R_{SC}$	Allowed THD of mains current	Allowed distortion factor of mains current
$\geq 1000$	THD > 48%	K > 45%
$\geq 120$	THD $\leq$ 48%	K $\leq$ 45%
> 33	THD < 13%	K < 12 %

Fig.7-13: Required THD/distortion factor with given Rsc of the mains (U < 600 V)

Measures to comply with the maximum allowed THD or distortion factor:

- use of mains chokes
- use of supply units with incorporated power factor correction PFC



The following fact applies to the mains choke: the higher the inductance of the mains choke, the lower the TDH/distortion factor and the mains pollution.

Kind of device	Realizable THD of mains current	Realizable distortion factor of mains current	Supply unit or drive controller with and without mains choke	
all devices	THD $\geq$ 50%	K $\geq$ 60%	HMV01.1E HCS03.1 HCS02.1	without
devices with mains choke	THD < 48%	K < 45 %	HMV01.1E HCS03.1 HCS02.1	HNL01.1
devices with Power Factor Control (PFC)	THD < 13%	K < 12 %	HMV01.1R HMV02.1R	HNL01.1 HNL02.1

Fig.7-14: Realizable THD / distortion factor for drive controllers



The allowed distortion factors can be achieved with the indicated combinations of drive controller and mains choke.



Observe the assignment of mains choke to drive controller in the Project Planning Manual "Rexroth IndraDrive Supply Units and Power Sections" → Chapter of the respective device → "Technical Data" → "Basic Data" → table "Data for mains voltage supply".

For detailed information on the emitted harmonics, see this Project Planning Manual in chapter [16.2.4 Calculations for the Mains Harmonics](#), page 332.

Procedure for selecting the required mains connection components:

1. Determine maximum current I of mains connection.

Note: Classification for public mains according to European standards in

Selecting Mains Connection Components

## Project Planning of Mains Connection

- $I < 16$  A (EN 61000-3-2)
  - $16$  A  $< I < 75$  A (EN 61000-3-12)
  - $I > 75$  A (not defined by any standard at present)
2. Determine mains short-circuit power  $S_k$  of mains at place of destination of application (ask power supply company).
  3. Determine sum of connected loads  $S_A$ .
  4. Determine ratio  $R_{SC}$ .
  5. Determine allowed THD or distortion factor  $K$  of mains current at place of destination of application (ask power supply company).
  6. Select appropriate mains supply unit with additional component.



The table below does not replace the described procedure.

The table is used for first estimation of maximum allowed connected load  $S_A$  at point of power supply connection in low-voltage mains at known mains short-circuit power  $S_k$ .

Classification	$S_k$	$R_{SC} = 250$	$R_{SC} = 200$	$R_{SC} = 100$	$R_{SC} = 50$
		$S_A$	$S_A$	$S_A$	$S_A$
	MVA	kVA	kVA	kVA	kVA
1 rigid mains	200	800	1000	2000	4000
	150	600	750	1500	3000
	100	400	500	1000	2000
	50	200	250	500	1000
2 semi-rigid mains	40	160	200	400	800
	30	120	150	300	600
	20	80	100	200	400
	15	60	75	150	300
	10	40	50	100	200
	5	20	25	50	100
	4	16	20	40	80
3 non-rigid mains	3	12	15	30	60
	2	8	10	20	40
	1	4	5	10	20
	0,6	2,40	3	6	12

$R_{SC}$

mains short-circuit ratio

$S_k$

mains short-circuit power

$S_A$

connected load of all electric loads at connection point (apparent power of fundamental wave)

Fig.7-15:

Maximum allowed connected load

## Project Planning of Mains Connection

# 7.5 Protection Systems at the Mains Connection

## 7.5.1 General Information

Protection against contact always depends on the kind and structure of the supply mains and the mains conditions. For project planning of an installation, the typical behavior of the devices and supply mains should always be taken into account.

For protection against contact (indirect contact) in a machine or plant in which a drive system is used, the overcurrent protective device normally used is one with protective grounding according to IEC 364 and EN 50178 (Electronic equipment for use in power installations). This is also specified in UL 508C (Industrial Control Equipment) for North America. Housing cover or encapsulation by closed housing is used as protection against direct contact with live conductors.

## 7.5.2 Protective Grounding

### General Information

Overcurrent protection normally is realized in the form of fuses or overcurrent release devices (circuit breakers, motor circuit breakers) installed at the mains connection. For details see figure.

Overcurrent protection generally is dimensioned or set with a release current of  $1.3 \times$  nominal current of the loads connected to this connection point.

In the case of an insulation error or a connection between mains phase and device housing connected to the equipment grounding conductor, the drive is disconnected from the mains.

### Fusing by Protective Grounding in TN-S Mains

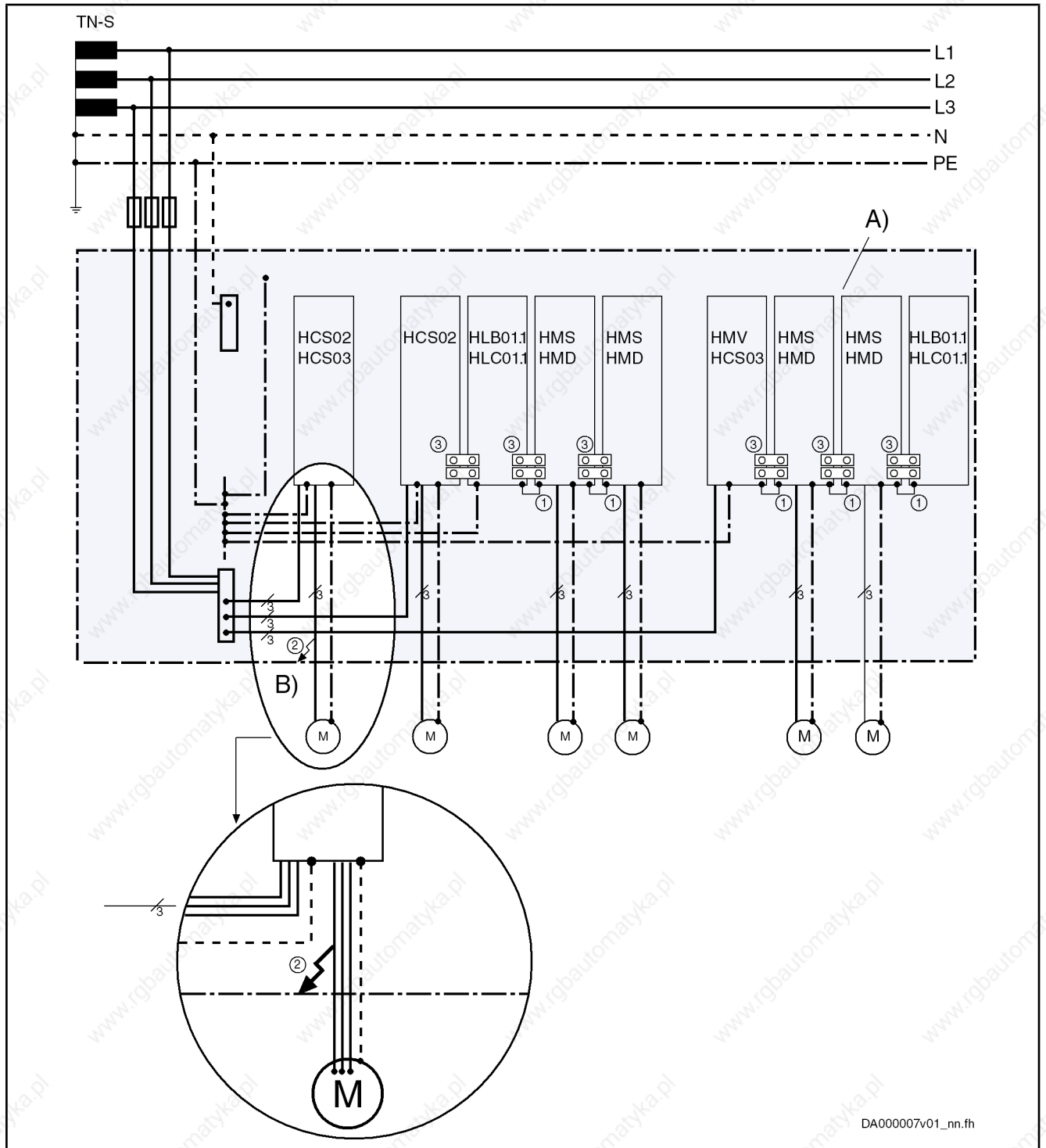

DA000007v01\_nn.fh

- A) control cabinet
- B) error
- ① joint bar of equipment grounding conductors
- ② aim of protective measures: contact voltage < 50 V at housing
- ③ DC bus connection L+/L-

Fig.7-16: Protection against contact by protective grounding with overcurrent protection device in TN-S mains

Project Planning of Mains Connection

Fusing by Protective Grounding in TN-C Mains

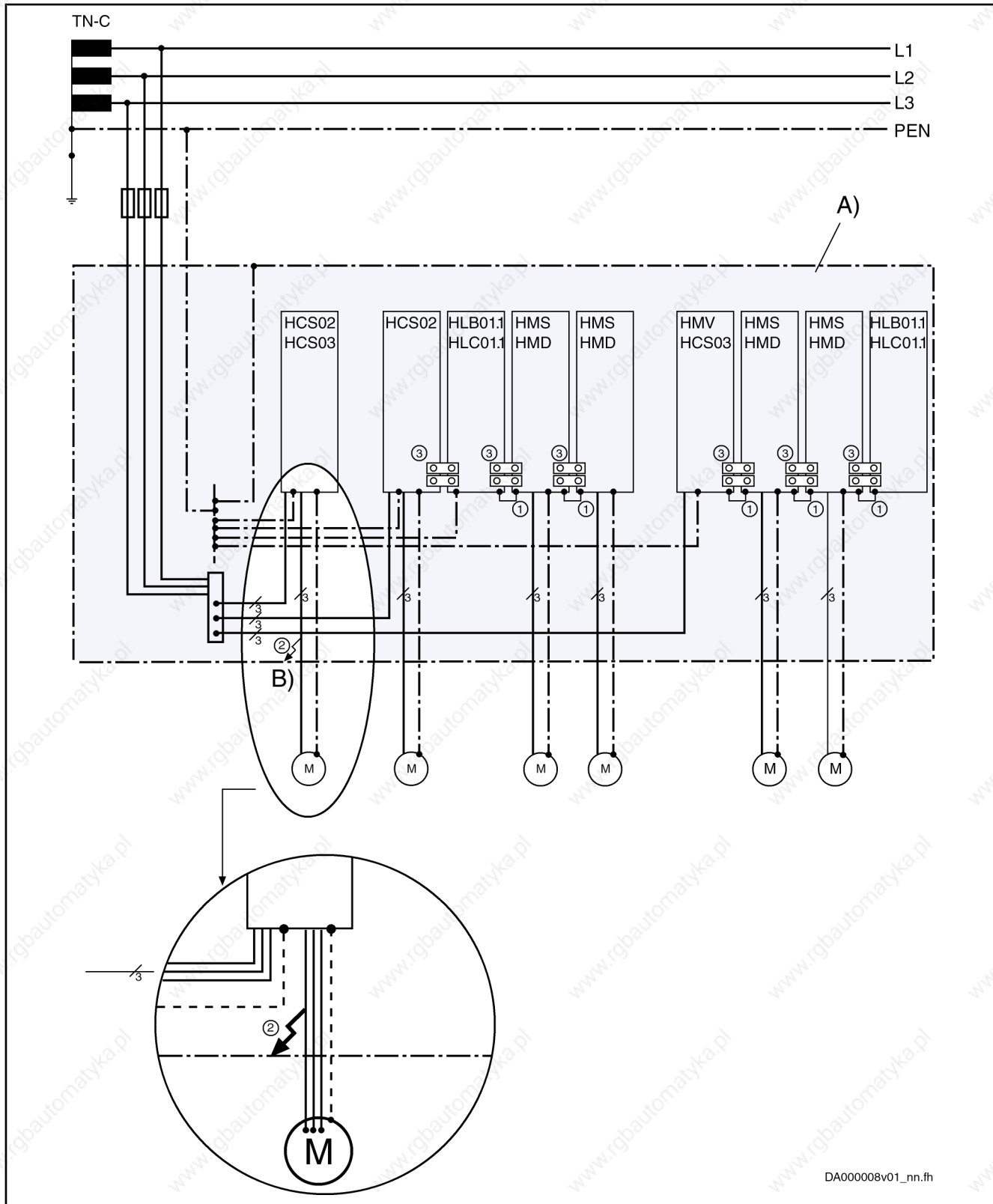

DA000008v01\_nn.fh

- A) control cabinet
- B) error
- ① joint bar of equipment grounding conductors
- ② aim of protective measures: contact voltage < 50 V at housing
- ③ DC bus connection L+/-

Fig. 7-17: Protection against contact by overcurrent protection device in TN-C



Project Planning of Mains Connection

*mains*

Project Planning of Mains Connection

Fusing by Protective Grounding in IT Mains (Ungrounded Mains)

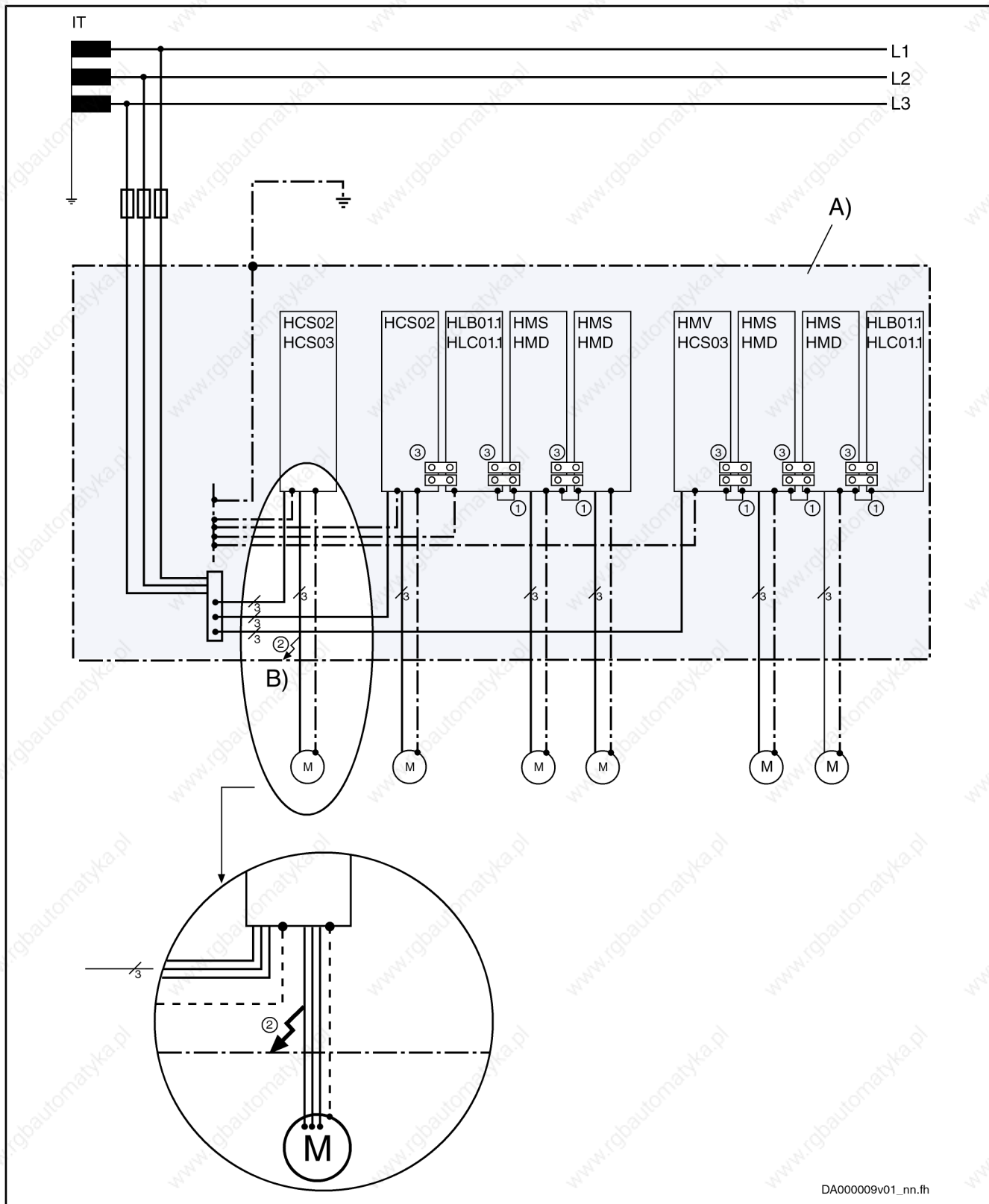

DA000009v01\_nn.th

- A) control cabinet
- B) error
- ① joint bar of equipment grounding conductors
- ② aim of protective measures: contact voltage < 50 V at housing
- ③ DC bus connection L+/L-

Fig.7-18: Protection against contact by overcurrent protection device in IT mains

## Rating of Mains Circuit Breaker



### High contact voltage in the case of error!

#### Do not exceed maximum allowed ground resistance !

Select the mains circuit breaker such that the disconnecting times in the case of error (short circuit or ground fault) according to VDE0100-410 and VDE0100-540, as well as the maximum ground resistance required for this purpose are complied with:

- nominal fuse current  $\leq 32 \text{ A}$ : max. disconnecting time **0.2 s**
- nominal fuse current  $> 32 \text{ A}$ : max. disconnecting time **5 s**

Determine the maximum allowed ground resistance at the site of installation with the tripping current (see tripping characteristic of selected fuse) and the maximum allowed contact voltage 50 V.



Rated currents for the mains circuit breakers and mains contactors: see Project Planning Manual "Rexroth IndraDrive Supply Units and Power Sections" → Chapter of the respective device → "Technical Data" → "Basic Data" → table "Data for mains voltage supply"

The data apply under the following conditions:

- the mains supply units and converters are operated with individual supply
- in the arithmetical mean, the indicated continuous power  $P_{DC\_cont}$  is not exceeded for 10 minutes
- easily separable contact-welded connections at the (external) contactor are allowed after short-circuit; corresponds to assignment type "2" according to DIN IEC 60947-4

Applications deviating from these conditions require detailed calculation of the mains connection values.

If several drive controllers are to be operated at one fuse and one mains contactor, add the mains-side phase currents and inrush currents calculated for the individual drives.



### Damage to the drive controller caused by overload!

Observe the specified performance data peak power and continuous power.

Selectively fuse the mains connection of each drive system. The fuse must protect the drive controller with the lowest mains connected load.

The indicated types of certain manufacturers are examples. Equivalent products by other manufacturers may be used as well.



In order to prevent the mains contactor from being overloaded by the load current in the case of frequent cut-off:

- first switch off the drive, e.g. via drive enable in the master communication
- then switch off the mains contactor

## Project Planning of Mains Connection



Fuses of **characteristic gR** can protect the involved semiconductors against further damage in the case of short circuit.

Fuses of **characteristic gL** protect the lines.

For the switch-off delay of the mains contactor see the technical data of the selected type. Take into account that additional components at the operating coil cause changes in the switch-off delay.

**Fusing Branches Within the Control Cabinet**

In the wiring of the drive system devices, there are branches run from main lines to short circuit protection devices.

According to EN 60 204 part 1, 5.2.4, such supply lines to short circuit protection devices branching off main lines do not need to be especially protected against short circuit, when the following requirements have been fulfilled:

- The supply lines to the short circuit protection device have at least the cross section of the conductors continuing the line from the short circuit protection device (line cross sections from and to motor circuit breaker have the same size).
- No supply line to the short circuit protection device is longer than 3 m.
- The lines are protected against external influence by a housing or a wiring duct.
- The lines are not run close to combustible material.

**7.5.3 Connecting Equipment Grounding Conductor****General Information****WARNING**

**Lethal electric shock when touching the housing caused by faulty connection of equipment grounding conductor!**

Observe the mentioned notes on installation in any case, in order to exclude danger by electric shock when touching the housing, even in case an equipment grounding conductor connection is broken.

**Equipment Grounding Connection Between the Components**

Observe the notes on installation in chapter [13.1.4 Connection Point of Equipment Grounding Conductor and Equipment Grounding Connections](#), page 182.

**Connecting Equipment Grounding Conductor to Mains**

According to the standards "Electronic equipment for use in power installations" (EN50178, chapter 5.3.2.1) and "Adjustable speed electrical power drive systems" (EN 61800-5-1, chapter 4.2.5.4.2), a **stationary connection** of the equipment grounding conductor is required and one or more of the following requirements have to be complied with:

- cross section of equipment grounding conductor at least 10 mm<sup>2</sup> (reason: sufficient mechanical stability required)
- mains and current supply automatically cut off when equipment grounding conductor interrupted (case of error)
- Routing of a second equipment grounding conductor, via separate terminal connectors, with the same cross section as the first equipment grounding conductor. Mounting of an additional terminal connector for this equipment grounding conductor.

## 7.5.4 Residual-Current-Operated Circuit Breakers (RCD, RCCB) as Additional Fusing

### General Information

The following designations are used for residual-current-operated circuit breakers:

- RCCB (Residual-Current-Operated Circuit Breaker)
- RCD (Residual-Current-Operated Device)
- RCM (Residual-Current Monitoring Device)
- earth-leakage circuit breaker (voltage-independent)
- residual-current circuit breaker (voltage-dependent)



---

Residual-current-operated circuit breakers can only be used with Rexroth IndraDrive systems to a limited extent.

---

If these circuit breakers are to be used, the company erecting the installation has to check the mutual compatibility of the residual-current-operated circuit breakers and installation or machine with the drive system, in order to avoid accidental triggering of the residual-current-operated circuit breaker. This has to be taken into account

- for switch-on processes, due to high asymmetric inrush currents and
- during operation of the installation, due to leakage currents produced in normal operation.

### Cause of Leakage Currents

For the purpose of stepless speed variation with a high degree of positioning accuracy and dynamic response, certain modulation procedures are necessary for drive systems. For physical reasons, these modulation procedures give rise to inevitable leakage current produced during normal operation. Especially with unbalanced loads of the mains phases or a large number of drives it can easily reach some amperes (rms value).

The leakage current is not sinusoidal but pulse-shaped. For this reason, measuring instruments normally dimensioned for alternating currents in the range of 50 Hz are not suited. Use measuring instruments with rms value measuring ranges up to at least 150 kHz.

The degree of leakage current depends on the following features of the installation:

- kind of inrush current limitation
- number, kind and size drives used
- length and cross section of connected motor power cables
- grounding conditions of the mains at the site of installation
- imbalance of the three-phase system
- kind of filters and chokes connected in the incoming circuit
- EMC measures that are taken

If measures are taken to improve the electromagnetic compatibility (EMC) of the installation (mains filters, shielded lines), the leakage current in the ground wire is inevitably increased, especially when switching on or in the case of mains unbalance. Given these operating conditions, residual-current-operated circuit breakers can trigger without an error having occurred.

## Project Planning of Mains Connection

The EMC measures are mainly based on capacitive short-circuiting of the interference currents within the drive system. Inductive filter measures can reduce the leakage currents, but affect the dynamic response of the drive and bring about higher construction volume, higher weight and expensive core material.

**Possibilities of Use****Motor Cable Length**

Keep the motor cables as short as possible. Only short motor cables do allow low leakage currents and thereby enable residual-current-operated circuit breakers to work.

**Kinds of Residual-Current-Operated Circuit Breakers**

There are two kinds of residual-current-operated circuit breakers:

1. **Residual-current-operated circuit breakers sensitive to power pulse current (type A acc. to IEC 60755)**

These are normally used. However, it is only pulsating direct fault currents of a maximum of 5 mA and sinusoidal alternating fault currents that they switch off safely. This is why they are not allowed for devices that can generate smoothed direct fault currents. In the case of smoothed direct fault currents that can be produced in power supply units, mains rectifiers and drive controllers with power converters in B6 circuit, the residual-current-operated circuit breaker is not triggered. This blocks the triggering of a residual-current-operated circuit breaker sensitive to power pulse current in the case of ground contact, i.e. in the case of error.

**Residual-current-operated circuit breakers sensitive to power pulse current do not provide any protection against inadmissible contact voltage.**

2. **Residual-current-operated circuit breakers sensitive to universal current (type B acc. to IEC 60755)**

These circuit breakers are suited for smoothed direct fault currents, too, and safely switch off devices with B6 input rectifiers.

When a current with 30 mA triggers the residual-current-operated circuit breaker, it is possible to use a residual-current-operated circuit breaker with higher tripping current for machine protection.

If this residual-current-operated circuit breaker triggers accidentally, too, check in how far the above conditions and dependencies can be improved (for example, by connecting current-compensated mains chokes in the incoming circuit, increasing the inrush current limitation).

**Using Isolating Transformer to Reduce Leakage Current in Mains**

If there is no improvement achieved and the residual-current-operated circuit breaker, due to specific mains conditions on site, has to be used nevertheless on the mains input side, connect an isolating transformer between mains connection and power connection of the drive system. This reduces the leakage current in the ground wire of the mains that is produced during normal operation which allows using the residual-current-operated circuit breaker. Connect the neutral point of the secondary winding of the isolating transformer to the equipment grounding conductor of the drive system.

Adjust the ground-fault loop impedance to the overcurrent protective device so that the unit can be switched off in the case of failure.

Before operating enable, check the correct function of the overcurrent protection device including activation in the case of failure.

**Exclusive fusing by residual-current-operated circuit breaker**

For drive systems with electronic drive controllers, exclusive protection by means of a residual-current-operated circuit breaker normally is not possible and not allowed.



Electronic equipment that has a nominal power higher than 4 kVA or is destined for permanent connection does not need residual-current-operated circuit breakers.

According to IEC 364 and EN 50178, the supply-side protection against contact for indirect contact, i.e. in the case of insulation failure, has to be provided in a different way, for example by means of overcurrent protective device, protective grounding, protective-conductor system, protective separation or total insulation.

## Using Residual-Current-Operated Circuit Breakers at HCS Drive Controllers

### HCS02 Drive Controllers at Residual-Current-Operated Circuit Breaker

At HCS02 drive controllers, residual-current-operated circuit breakers can be used under the following conditions:

- residual-current-operated circuit breaker is of type B (IEC60755)
- trip limit of the residual-current circuit breaker is  $\geq 300$  mA
- supplying TN-S mains
- maximum length of motor cable 20 m in shielded design
- use of a mains filter HNF01 or NFD03
- each residual-current-operated circuit breaker only supplies one HCS02 drive controller
- only Rexroth components and accessories including cables and filters are used

## Using Residual-Current-Operated Circuit Breakers at HMV Supply Units

### HMV01.1R, HMV02.1R at Residual-Current-Operated Circuit Breaker

Due to their function, regenerative HMV0x.1R supply units are unsuitable for the use of residual-current-operated circuit breakers.

## 7.5.5 Insulation Monitoring Devices

Insulation monitoring devices are normally used in IT mains with insulated neutral point. The aim is to have a monitor triggered in the case of ground fault – which means in the case of error – without having to switch off the electrical equipment.

When the monitor signals an error, the ground fault is detected and removed without operation being interrupted. Switch-off only takes place if a second ground fault occurs before the first one has been removed.

As insulation monitoring devices are also measuring the ground current at the mains input of the building, too high leakage current can cause accidental false triggering.

There are the same notes on application applying as mentioned in the previous chapter [7.5 Protection Systems at the Mains Connection, page 60](#).





## 8 Configuration of the Drive System

### 8.1 General Information

Within the product range Rexroth IndraDrive, you may combine components of the subranges Rexroth IndraDrive C and Rexroth IndraDrive M, as well as Rexroth IndraDrive Mi.

You have to select:

#### *Supply*

- supply units
- converters
- type of mains connection
- additional component mains filter
- other additional components for mains connection

#### *Drive*

- motors with measuring systems
- power sections
- control sections with options
- firmware for selected power sections with control section

#### *Additional components*

- for the DC bus
- for the motor output

#### *Cables*

- for power supply to the motor
- for signal evaluation from motor to control electronics

### 8.2 Kind of Supply for Power Sections

#### 8.2.1 General Information

The requirements to the individual axes are known from the drive task and the appropriate drive controllers - the drive system - have been selected for this purpose. For this drive system, select the appropriate supply. The following list will be explained in detail in this chapter:

- supply by **HMV** supply unit
  - in central supply
  - in parallel operation
- supply by **HCS** converter
  - in central supply
  - in parallel operation
- supply by **third-party supply units (preliminary)**
  - **RD500 - SFT** converter



---

It is not allowed to use supply units not contained in this list to supply the IndraDrive components.

---

Configuration of the Drive System



In the **scope of UL**, it is exclusively the following supply units which have been approved for supplying IndraDrive components:

- HMV01.1R
- HMV01.1E
- HMV02.1R
- HCS02.1E
- HCS03.1E

Orientation guide for selecting kind of supply

Criterion	HMV supply unit		HCS converter	
	Central supply with HMVxx.x	Parallel operation with HMVxx.xE (not W0030)	Central supply	Parallel operation
number of axes = 1	x	x	■	-
1 < number of axes ≤ 6	■	□	■	■
6 < number of axes ≤ 12	■	□	□	□
12 < number of axes ≤ 21	■	■	-	-
number of KCU01 = 1	■	■	■	■
1 < number of KCU01 ≤ 4	■	■	-	-
high overload ratio	■	■	□	□
regenerative operation with great energy contents	■ HMVxx.xR	□	□	□
high kinetic energies in the case of mains failure	x	□ additionally use braking resistors	□ additionally use braking resistors	□ additionally use braking resistors
single-phase operation	-	-	□ only HCS02	-

- recommended
- suited to a limited extent
- x possible
- not allowed

Fig. 8-1: Orientation guide



**CAUTION**

**Property damage caused by operation of combinations which are not allowed!**

Only operate the listed, allowed combinations.

Operating components not mentioned in this documentation at the common DC bus with Rexroth IndraDrive components requires Rexroth's explicit confirmation.

HMVs are the preferred supply units for HMS, HMD and KCU inverters. HCS converters can be used, too, as supply units for HMS, HMD and KCU. The table

## Configuration of the Drive System

below shows the general assignment. In addition, observe the detailed notes on project planning in the corresponding section.

Supply unit / converter	HMS01	HMS02 <sup>1)</sup>	HMD01	HCS02	HCS03	KCU01
HMV01.1E	■	-	■	-	-	■ <sup>3)</sup>
HMV01.1R	■	-	■	-	-	■ <sup>3)</sup>
HMV02.1R	-	■	-	-	-	■
HCS02	■ <sup>3)</sup>	■	■ <sup>3)</sup>	■	-	■ <sup>2)</sup>
HCS03	■	-	■	-	■	■ <sup>3)</sup>

- allowed
- not allowed
- 1) HMS02 not with HMS01/HMD01
- 2) only HCS02.1E-W0054, -W0070 with additional capacitances at the DC bus
- 3) different mounting depths: control cabinet adapter HAS03 required

Fig. 8-2: Supply units for power sections



#### KCU01 at HMV and HCS - number of axes, capacitances $C_y$

The electronic control system KCU01 allows operating a motor string of several KSM at the DC bus of Rexroth IndraDrive supply units and converters. KCU01 acts like an extension of the DC bus up to the inverters integrated in KSM.

A KCU01 with maximum hybrid cable length loads the supply unit like, for example, 5 devices HMS01.1N-W0110 (5 axes,  $C_y = 5 \times 100 \text{ nF}$ ).



For the project planning of HMS and HMD inverters at HCS converters, take the following aspects into account for use in the scope of UL:

- The maximum output voltage ( $U_{DC}$ ) of the supplying device (e.g. HCS) must be smaller than the allowed input voltage of the inverter (e.g. HMS).
- The symmetrical nominal short-circuit current at the mains connection ( $I_{SCCR}$ ) of the supplying device (e.g. HCS) must be smaller than the symmetrical nominal short-circuit current specified for the inverter (e.g. HMS).

## 8.2.2 HMV Supply Units for HMS/HMD Power Sections

### Central Supply HMV

#### Brief Description

The mains connection "central supply" (individual supply) is the standard type of connection for HMV. The "central supply" is characterized by one mains connection (mains circuit breaker, mains transformer, mains filter, mains choke) for the drive system. Other drive controllers and additional components are connected to the supply unit.

Configuration of the Drive System

Block Diagram

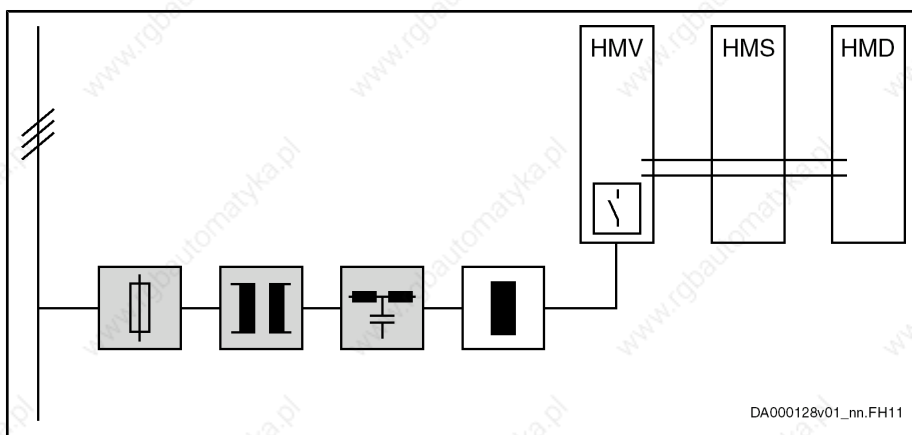

DA000128v01\_nn.FH11

HMVxx.xE components marked with gray background color: optional, depending on the application

HMVxx.xR mains filter and mains choke; necessary

HMVxx.xR-W0120 mains filter, mains choke, external mains contactor; necessary

Fig. 8-3: Individual supply HMV

The "group supply without DC bus connection of the groups" has to be handled like individual supply for HMV.

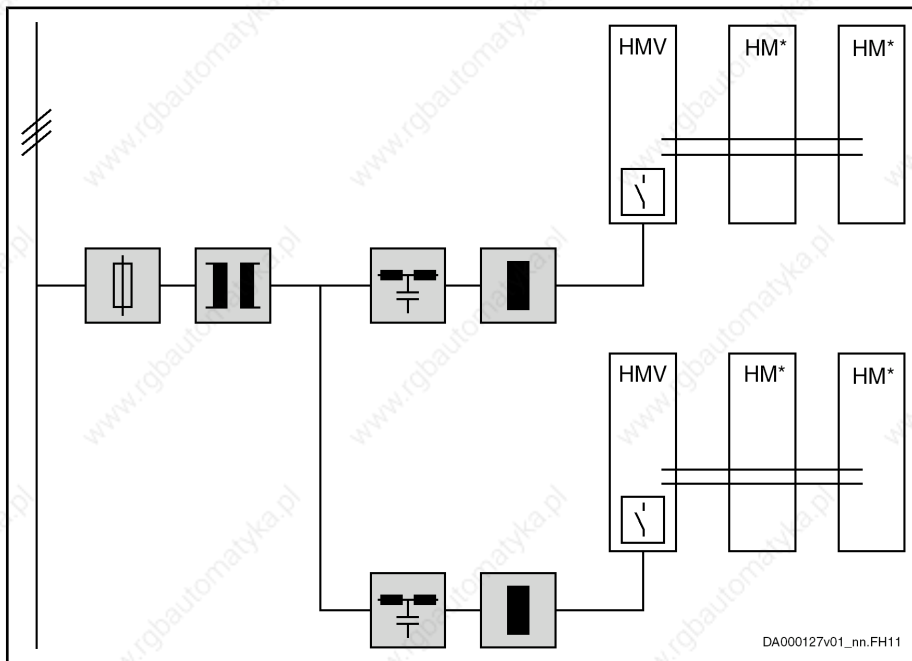

DA000127v01\_nn.FH11

HMVxx.xE components marked with gray background color: optional, depending on the application

HMVxx.xR mains filter and mains choke; necessary

HMVxx.xR-W0120 mains filter, mains choke, external mains contactor; necessary

Fig. 8-4: Group supply HMV without DC bus connection of the groups

Notes on Project Planning

For mains connection, observe the control circuit for the mains connection.

Up to the indicated maximum allowed **number of devices, drive controllers** may be operated at the common DC bus. The number is limited by the charging ability of HMV to charge capacitances against ground in the connected components.

For the selected number of axes, select the appropriate mains filter and mains choke with the required EMC limit value. This may result in a limitation with

## Configuration of the Drive System

regard to the number of axes and the motor cable length; the limitation can be resolved by division into several systems.

**Damage to the supply unit!**

Do not exceed allowed peak and continuous powers in the DC bus.

Comply with minimum value of mean phase control factor  $\bar{\alpha}$  (see data of continuous power of supply unit in the technical data, calculation see chapter 16, [Calculations, page 319](#)), in order to avoid overload of the integrated DC bus capacitors by wattless currents.

High load due to wattless current is generated, when, for example, synchronous motors permanently deliver high torque at low speed or asynchronous motors are operated with high magnetization currents.

In these cases of operation, use additional capacitances at the DC bus.

**Central Supply HMV - Number of Components**

Supply unit		IndraDrive components at common DC bus with supply via HMV devices		
Type	Charging ability capacitances $C_y$ [nF]	Allowed number of axes	HLB01.1	HLC01.1
HMV01.1E-W0030	2100	21 (21 × HMS01 or 11 × HMD01) or 4 × KCU01	2 × HLB01.1C or 2 × HLB01.1D	take max. allowed external DC bus capacitance $C_{DCext}$ into account
HMV01.1E-W0075	2100			
HMV01.1E-W0120	2100			
HMV01.1R-W0018	2100			
HMV01.1R-W0045	2100			
HMV01.1R-W0065	2100			
HMV01.1R-W0120	2100			
HMV02.1R-W0015	2100	12 (12 × HMS02) 1 × KCU01		

Fig. 8-5: Allowed Rexroth IndraDrive M components at common DC bus

**Parallel Operation HMV - Group Supply With DC Bus Connection HMV01, HMV02****Brief Description**

"Group supply with DC bus connection" increases the available regenerative power, the continuous braking resistor and infeeding power in the common DC bus of several drive controllers.

This mains connection is mainly used to cover the power range above the biggest modular supply unit.

Configuration of the Drive System

Block Diagram

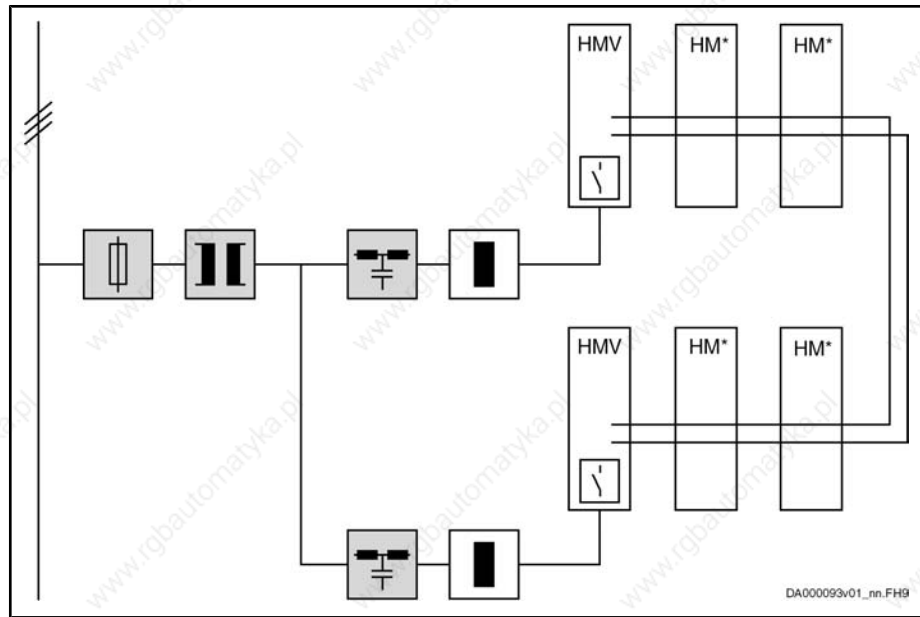

HMVxx.xE components marked with gray background color: optional, depending on the application  
 HMVxx.xR mains filter and mains choke; necessary  
 HMVxx.xR-W0120 mains filter, mains choke, external mains contactor; necessary

Fig. 8-6: Parallel operation - group supply HMV with DC bus connection

Notes on Project Planning



Parallel operation of regenerative supply units **HMV0x.xR is not allowed!**

For mains connection, observe the control circuit for the mains connection.

Parallel operation of HMV01 supply units

- is allowed with HMV01.1E supply units of the same **type current**
- requires a **mains choke** for each supply unit (for current sharing)
- does not increase the maximum allowed number of drive controllers or axes when operated without mains filter
- requires a control circuit master-slave; see chapter 9 , [Control Circuits for the Mains Connection, page 111](#).

For detailed information on derating and mounting, there is the specification with document number 109-1261-4102-\*\* (available on request).

For the selected number of axes, select the appropriate mains filter and mains choke with the required EMC limit value. This may result in a limitation with regard to the number of axes and the motor cable length; the limitation can be resolved by division into several systems.



One HMV01.1E-W0075 device replaces two HMV01.1E-W0030 devices connected in parallel.

Parallel Operation HMV - Number of Components

Supply unit type	Number of supply units at common DC bus							
	E-W**** (infeeding)			R-W**** (regenerative)				
HMV01.1	0030	0075	0120	0018	0045	0065	0120	0015



Supply unit type	Number of supply units at common DC bus							
HMV01.1E-W0030	2	-	-	-	-	-	-	-
HMV01.1E-W0075	-	2	-	-	-	-	-	-
HMV01.1E-W0120	-	-	2	-	-	-	-	-
HMV01.1R-W0018	-	-	-	1	-	-	-	-
HMV01.1R-W0045	-	-	-	-	1	-	-	-
HMV01.1R-W0065	-	-	-	-	-	1	-	-
HMV01.1R-W0120	-	-	-	-	-	-	1	-
HMV02.1R-W0015	-	-	-	-	-	-	-	1

- not allowed

Fig. 8-7: Parallel operation HMV

## 8.2.3 Converter HCS as Supply Unit for Power Sections

### General Information

Converters are designed for operating a single drive (see also Individual Supply with HCS). In particular, the power supply with the capacitors in the DC bus and the mains supply have been dimensioned with regard to operation under rated conditions of the converter. When HCS converters are used as supply units for further drive controllers, the power ( $P_{DC\_cont}$ ,  $P_{DC\_peak}$ ) of the converter is available at the motor output and at the DC bus connection of the converter. This causes additional loading which requires **additional measures** when the converter is used as supply unit. The measures reduce, for example, the resulting (higher) current load of the capacitors in the DC bus.



CAUTION

#### Damage to the converter!

Comply with the allowed peak power and continuous power ( $P_{DC\_cont}$ ,  $P_{DC\_peak}$ ) of the supplying drive controller.

### Central Supply - HCS Supply HCS or HMS/HMD Drive Controllers

#### Brief Description

The "central supply" via HCS converters is the mains supply with which the converter supplies further drive controllers.

Configuration of the Drive System

Block Diagram

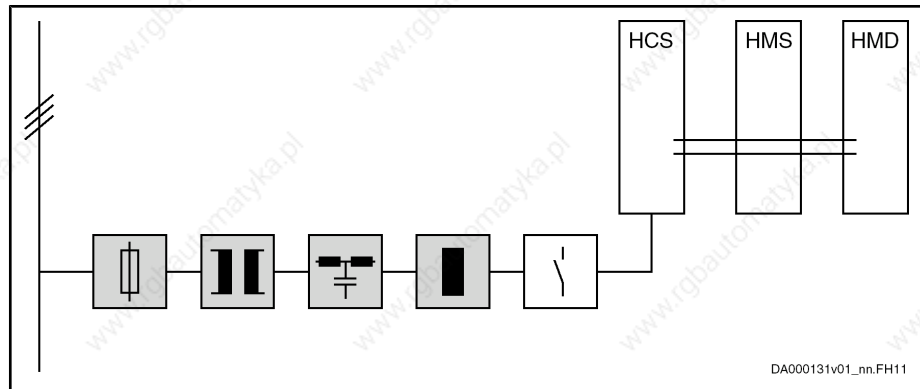

components marked with gray background color: optional, depending on the application

Fig. 8-8: Central supply HCS



When using the component HCS03.1E with HNK01.1, connect the mains contactor electrically before HNK and HCS03.

The "group supply without DC bus connection of the groups" allows using the additional components (HNL, HNF etc.) in the mains connection for several similar supplies.

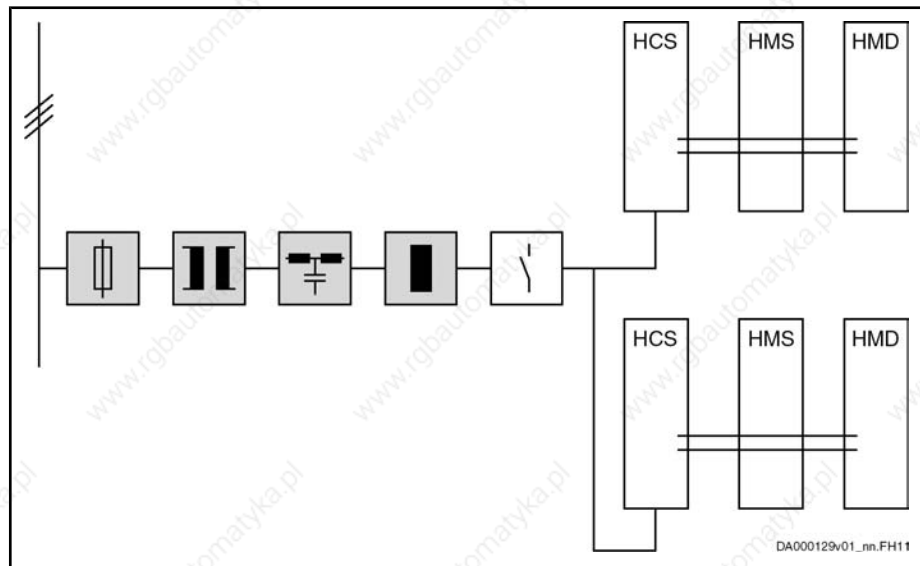

components marked with gray background color: optional, depending on the application

Fig. 8-9: Group supply HCS without DC bus connection of the groups



Control the mains contactor in such a way (connect Bb contacts in series) that errors of both groups lead to circuit interruption.

Notes on Project Planning HCS02

HCS02 converters as supply units for HMS01 / HMD01 require:

- accessory **HAS03** (to adjust different mounting depths)
- accessory **HAS04** (capacitances  $C_y$  at DC bus against ground)
- additional capacitors  $C_{DC\_ext}$  at the DC bus (external DC bus capacitance  $C_{DCext}$ ), if
  - the arithmetical mean of the output currents  $I_{out}$  is **greater than**  $I_{out\_cont}$  of the supplying device

## Configuration of the Drive System

- the accumulated chronological sequences of the output currents  $I_{out}$  and the DC bus power  $P_{DC}$  (superposition of the individual load profiles) are **greater than** the allowed load profiles

**Additional capacitance  $C_{DC\_ext}$  required for HCS02!**

To determine the additionally required capacitance  $C_{DC\_ext}$ , the following **guide values** apply when using an HLC01.1 DC bus capacitor unit:

- 10  $\mu\text{F}$  per A type current of installed HMS01 drive controllers
- 20  $\mu\text{F}$  per A type current of installed HMD01 drive controllers
- 50  $\mu\text{F}$  pro kW of installed continuous power KCU01

There aren't any additional capacitances required for HMS02.

**Arrangement of HCS02**

Place HCS02 to the left of HMS01, HMS02 and HMD01.

Place the accessory HAS04 at the left of HCS02.

Place the DC bus capacitor unit HLC01.1 at the junction from HCS02.1 to HMS01.1 or HMD01.1.

**Notes on Project Planning HCS03**

HCS03 converters as supply units for HMS01 / HMD01 require braking resistors:

**Operate HCS03 with HLR!**

To supply HMD01 and HMS01, operate HCS03 converters with brake chopper (option -NNBV) and HLR braking resistor.

DC bus capacitors HLC01.1 may only be operated at HCS03.1E-W0210.

**Arrangement of HCS03**

Place HCS03 to the left of HMS01 and HMD01.

Place the accessory HAS04 at the left of HCS03.

**Notes on Commissioning**

When converters are operated as supply units for inverters or supplied as inverters from another converter, the drive controller must be parameterized for this purpose.



For information on configuration and parameterization of the drive controllers, see Functional Description of firmware, chapter "Power Supply" and the involved parameters.

- P-0-0860, Converter configuration
- P-0-0861, Power supply status word

## Configuration of the Drive System

## Central Supply HCS02 - Number of Components

Converter as supply unit	Number of IndraDrive components at common DC bus					
	HCS02.1E		Allowed sum of type currents	Allowed number of axes	HLB01.1C	HLC01.1C
central supply via <b>HCS02.1E-W0028</b> without assigned mains choke	-		-	-	1	1 (up to -02M4)
central supply via <b>HCS02.1E-W0054</b> without assigned mains choke	up to W0054		166	12	1	1 (up to -02M4)
central supply via <b>HCS02.1E-W0054</b> with assigned mains choke HNL01.1	up to W0054		222	12	1	take max. allowed external DC bus capacitance $C_{DCext}$ into account
central supply via <b>HCS02.1E-W0070</b> without assigned mains choke	up to W0070		264	12	1	1 (up to -02M4)
central supply via <b>HCS02.1E-W0070</b> with assigned mains choke HNL01.1	up to W0070		402	12	1	take max. allowed external DC bus capacitance $C_{DCext}$ into account
	<b>HMS01.1N</b> <b>HMS02.1N</b>	<b>HMD01.1N</b>			<b>HLB01.1C</b>	
central supply via <b>HCS02.1E-W0054</b> without assigned mains choke	up to W0036	up to max. W0020	120	12 (1 × HCS02 and 11 × HMS01	1	take max. allowed external DC bus capacitance $C_{DCext}$ into account
central supply via <b>HCS02.1E-W0054</b> with assigned mains choke HNL01.1	up to W0054	up to max. W0020	198	or 1 × HCS02 and 2 × HMS02	1	
central supply via <b>HCS02.1E-W0070</b> without assigned mains choke	up to W0036	up to max. W0020	120	or 1 × HCS02 and 5 × HMD01 and 1 × HMS01)	1	
central supply via <b>HCS02.1E-W0070</b> with assigned mains choke HNL01.1	up to W0054	up to max. W0036	270		1	

- not allowed

Fig. 8-10: Maximum number of IndraDrive C components at common DC bus HCS02

**Example HCS02** Central supply via HCS02.1E-W0070 with assigned HNL01.1 mains choke:

- 1 × HCS02.1E-W0070 (supplying device)
- 7 × HCS02.1E-W0028
- 2 × HCS02.1E-W0054
- 1 × HCS02.1E-W0070
- 1 × HLB01.1C

## Configuration of the Drive System

- 1 × HLC01.1C

How to check the combination:

1. Check sum of type currents to be supplied:  $7 \times 28 + 2 \times 54 + 1 \times 70 = 374$ ;  $374 < 402 \Rightarrow$  sum of type currents is allowed
2. Check sum of drive controller axes:  $1 \times 1 + 7 \times 1 + 2 \times 1 + 1 \times 1 = 11$ ;  $11 < 12$ ;  $\Rightarrow$  max. allowed number of axes is not exceeded
3. Check sum of drive controllers with braking resistor:  $1 \times 1 + 7 \times 1 + 2 \times 1 + 1 \times 1 + 1 \times 1 = 12$ ;  $12 \leq 12$ ;  $\Rightarrow$  max. allowed number of drive controllers is not exceeded

You may make replacements up to the maximum allowed sum of the type currents. For drive controllers with two motor outputs (e.g. HMD01), the **double** value of their type current applies.

### Central Supply HCS03 - Number of Components



In central supply, HCS03 converters cannot supply any other HCS03.

Supply unit	Number of IndraDrive components at common DC bus					
	HMS01.1N-	HMD01.1N-	Allowed sum of type currents	Allowed number of axes	HLB01.1D	HLC01.1D
central supply via <b>HCS03.1E-W0070</b> without assigned mains choke HNL01.1	up to W0054	up to W0036	120	12 (1 × HCS03 and 11 × HMS01 or 1 × HCS03 and 5 × HMD01 and 1 × HMS01)	1	-
central supply via <b>HCS03.1E-W0070</b> with assigned mains choke HNL01.1	up to W0054	up to W0036	270		1	-
central supply via <b>HCS03.1E-W0100</b> without assigned mains choke HNL01.1	up to W0070	up to W0036	270		1	-
central supply via <b>HCS03.1E-W0100</b> with assigned mains choke HNL01.1	up to W0070	up to W0036	270		1	-
central supply via <b>HCS03.1E-W0150</b> without assigned mains choke HNL01.1	up to W0070	up to W0036	270		1	-
central supply via <b>HCS03.1E-W0150</b> with assigned mains choke HNL01.1	up to W0070	up to W0036	270		1	-
central supply via <b>HCS03.1E-W0210</b> without assigned mains choke HNL01.1	up to W0150	up to W0036	270		1	take max. allowed external DC bus capacitance $C_{DCext}$ into account
central supply via <b>HCS03.1E-W0210</b> with assigned mains choke HNL01.1	up to W0150	up to W0036	270		1	take max. allowed external DC bus capacitance $C_{DCext}$ into account

- not allowed

(1) for explanation see chapter "Types of Mains Connection"

Fig. 8-11: Maximum number of IndraDrive C components at common DC bus HCS03

Configuration of the Drive System

**Example HCS03** Central supply via HCS03.1E-W0070 with assigned mains choke HNL01.1:

- 1 × HCS03.1E-W0070 (supplying device)
- 1 × HMS01.1N-W0054
- 1 × HMS01.1N-W0036
- 1 × HMS01.1N-W0020
- 1 × HMD01.1N-W0036
- 1 × HMD01.1N-W0020
- 2 × HMD01.1N-W0012

How to check the combination:

1. Check sum of type currents to be supplied:  $54 + 36 + 20 + 2 \times 36 + 2 \times 20 + 2 \times 12 \times 2 = 270$ ;  $270 \leq 270 \Rightarrow$  sum of type currents is allowed
2. Check sum of drive controller axes:  $1 + 1 + 1 + 1 + 1 \times 2 + 1 \times 2 + 2 \times 2 = 12$ ;  $12 \leq 12 \Rightarrow$  max. allowed number of axes is not exceeded

You may make replacements up to the maximum allowed sum of the type currents. For drive controllers with two motor outputs (e.g. HMD01), the **double** value of their type current applies.

**Parallel Operation HCS - Group Supply With DC Bus Connection of the Groups**

**Brief Description**

"Group supply with DC bus connection" increases the available regenerative power, the continuous braking resistor and infeeding power in the common DC bus of several drive controllers or drive systems.

Block Diagram

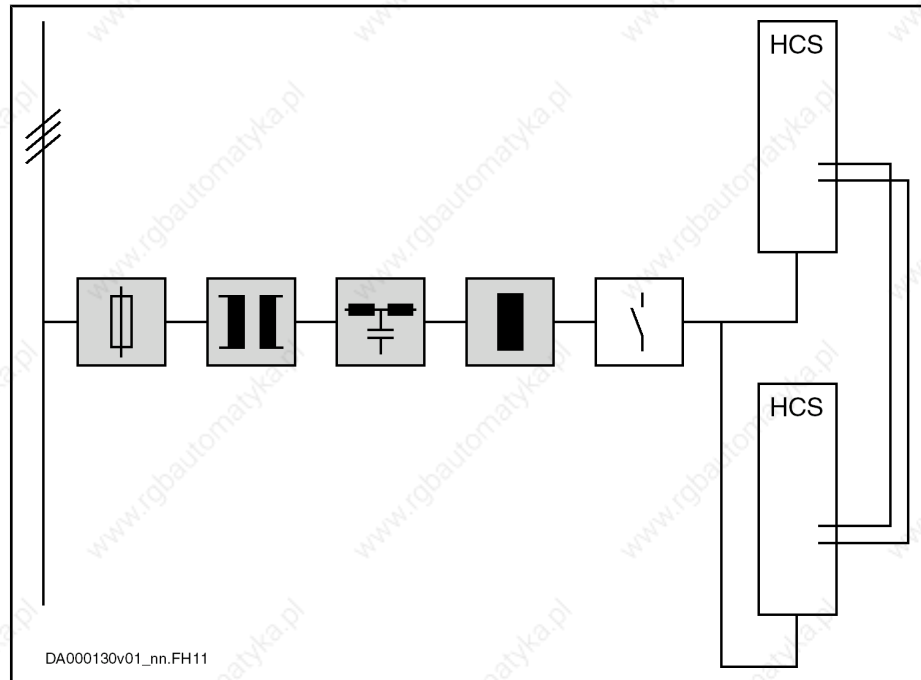

components marked with gray background color: optional, depending on the application

Fig.8-12: Parallel operation HCS

Notes on Project Planning



**Parallel operation**

Parallel operation is only allowed with drive controllers of the same type current.



**Connection lines**

The connection lines to the drive controllers should preferably have the same impedances in order to achieve balanced load distribution at the power input of the drive controllers. From the common node of the lines, you therefore have to make sure that

- the lengths of the supply lines and
- the cross sections of the supply lines are the same.

**Balancing factor**

At the common DC bus there is less than the sum of the device-specific performance data available. This particularly applies to the continuous DC bus power  $P_{DC\ cont}$  and the continuous regenerative power  $P_{BD}$ . The sum is generated with reduced performance data. The reduction takes place with the corresponding balancing factors for parallel operation.



For these data, see Project Planning Manual "Rexroth IndraDrive Supply Units and Power Sections" → Chapter of the respective device → "Technical Data" → "Basic Data" → table "Data of power section - DC bus".

**Parallel Operation HCS - Number of Components**

Converter	Number of IndraDrive C components at common DC bus		
		HLB01.1	HLC01.1
HCS02.1E-W0012	-	-	-
HCS02.1E-W0028	8	1	take max. allowed external DC bus capacitance $C_{DCext}$ into account <sup>1)</sup>
HCS02.1E-W0054	6	1	
HCS02.1E-W0070	4	1	
HCS03.1E-W0070	10	1	-
HCS03.1E-W0100	8	1	-
HCS03.1E-W0150	6	1	-
HCS03.1E-W0210	4	1	take max. allowed external DC bus capacitance $C_{DCext}$ into account

1) limited to the value of one converter  
- not allowed

Fig. 8-13: Parallel operation IndraDrive converters

**Example** Allowed parallel operation of HCS03.1E:  
6 × HCS03.1E-W00150

## 8.2.4 Third-Party Supply Units for Power Sections

### General Information

HMS01 and HMD01 power sections are designed to be supplied via HMV supply units or HCS converters. In exceptional cases, other supply units (called **third-party supply units** in the following paragraphs) can be used as supply units (e.g. SFT from the product range RD500). Third-party supply units cause loading which requires **additional measures**.



Configuration of the Drive System



The UL listing only applies to use with HMV supply units and HCS converters.

Block Diagram

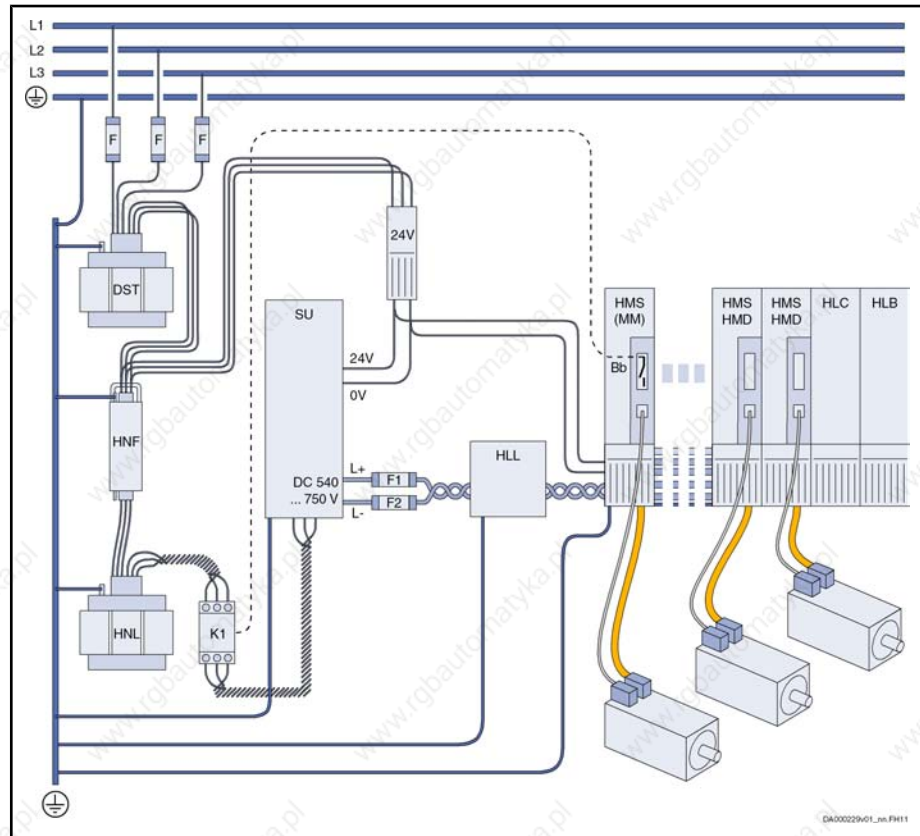

HLL DC bus choke  
 MM module bus master  
 SU third-party supply unit

Fig.8-14: Third-party supply unit with one drive system

Notes on Project Planning

Only HMS01 / HMD01 inverters, as well as additional components HLB and HLC, may be operated with third-party supply units.



Requirements to the **third-party supply unit**:

- **Minimum inductance:** In the mains connection of the third-party supply unit, install a mains choke with at least 100  $\mu\text{H}$ .
- **DC bus voltage:** The DC bus voltage of the third-party supply unit must be in the range DC 540 ... 750 V. Take the limit values  $U_{\text{DC\_LIMIT\_max}}$  of the supplied devices into account.
- **Allowed voltage control:** sine-wave modulation with  $f_s \geq 4.2 \text{ kHz}$ .  
 Third-party supply units with block modulation or flat-top modulation are **not** allowed.

Requirements to the **drive system**:

- **DC bus choke:** Per drive system, use one additional component HLL01.1N for connection to the DC bus of the third-party supply unit.
- **DC bus current:** Comply with maximum allowed DC bus current of 100 A.
- **Additional capacitances:** Use at least 50  $\mu\text{F}$  per kW of installed continuous power in the form of DC bus capacitor unit HLC01.
- **Leakage capacitance  $C_{ab}$ :** The leakage capacitance per drive system (motors and motor cables) mustn't be more than a maximum of 500 nF.

## Configuration of the Drive System

- **Capacitances against housing  $C_Y$ :** The total capacitance against housing per drive system mustn't exceed 850 nF and mustn't fall below 300 nF.
- **Peak voltage:** limit voltage L+ against  and L- against  to a maximum of 1 kV.
- If the drive system can be disconnected from the third-party supply unit in operation (e.g. in the case of overcurrent by fuses), use **DC bus resistor unit HLB01** with  $W_{max} \geq W_{max\_installiert}$ .

**Notes on Commissioning**

Supply units, converters, inverters and additional components of the Rexroth IndraDrive product range have a module bus X1. Via the module bus, information on the status within the drive system is exchanged and the power supply from the mains is influenced.

Supply units of other product ranges have no module bus. With the drive firmware as of version MPx04VRS, you can configure an inverter as module bus master. Integrate the relay contact of the module bus master configured as Bb contact in the control circuit of the power supply in such a way that the circuit is interrupted when the relay contact opens.



For information on configuration and parameterization of the drive controllers, see Functional Description of firmware, chapter "Power Supply" and the involved parameters.

- P-0-0860, Converter configuration
- P-0-0861, Power supply status word

Observe the notes in chapter 9 [Control Circuits for the Mains Connection](#), Seite 111.

## 8.3 Mains Connection Supply Units and Converters

### 8.3.1 General Information

The mains connection consists of:

- protection against overload (e.g. fuse for line protection)
- if necessary, an autotransformer or isolating transformer for voltage adjustment
- HNF mains filter
- HNL mains choke
- if necessary, combination of mains filter and HNK mains choke
- mains contactor (partly integrated for HMV)

**Notes on Project Planning**

By means of the tables in the following chapters, select the mains connection corresponding to the projected supply (HMV or HCS).

## Configuration of the Drive System

**CAUTION****Property damage due to mains filter overload!**

- Avoid series connection of mains filters as this can cause resonance effects on current and voltage.
- Only operate expressly allowed components at mains filters.  
Do not operate any other components, such as additional power supply units and blowers, at HNF mains filters.

With mains filters at compensation units, make sure there aren't any resonance effects on current and voltage.

Observe the allowed harmonic limit values (THD) of the filter components (see chapter [16.3.4 Determining the Allowed Operating Data of Mains Filters](#), page 336).

Make sure that the nominal current of the mains contactor does not exceed the nominal current of the mains filter.

**Control circuit for the mains connection**

Observe the chapter [9 Control Circuits for the Mains Connection](#), page 111.

**Mains filters HNF01, NFD at mains grounded via outer conductor**

HNF01.1 or NFD03.1 mains filters are not suited for operation on mains grounded via outer conductor. Therefore, use an isolating transformer, if necessary.

Allowed mains connection voltage: see technical data of the respective component

**Performance data without mains choke**

For operation without mains choke, take the reduced performance data of the supply units and converters into account.

Performance data: see technical data of the respective component

**EMC limits values and mains filter selection**

Explanation on dimensioning criterion EMC limit value class:

See chapter [Limit Values for Line-Based Disturbances](#), page 139

Calculation formulas for determining the allowed leakage capacitances:

See chapter [16.3.3 Determining the Leakage Capacitance](#), page 335

The mains filters used have been specifically dimensioned for Rexroth drive systems. For filters by other manufacturers, Rexroth cannot guarantee mains interference suppression with regard to allowed limit values.

The indicated EMC limit values apply to grounded mains. Ungrounded mains might possibly require additional measures.

The listed tables do not contain all practical applications (e.g. use of mains filters and mains chokes by several drive systems or exceeding the maximum motor line lengths). For such cases, mains filters and mains choke can be selected, too. See chapter:

- [16.3.1 Determining Mains Choke HNL](#), page 334

- 16.3.2 Determining Mains Filter HNF, page 334

## 8.3.2 Mains Connection of HMV Supply Units

### Mains Connection of HMV Supply Units



For interference-free operation of supply units with regeneration back to the mains (HMVxx.xR), use appropriate HNL mains chokes and HNF mains filters.

Supply unit	Transformer		Mains filter		Mains filter, mains switch	Mains choke		
	DST (auto)	DLT (isolating)	HNF01.1* ****-R****	HNF01.1* ****-E****		HNL01.1E; HNL01.1E- ****-S	HNL01.1R; HNL01.1R- ****-S	HNL 02.1
HMV01.1E	■	■	-	■	-	■	-	-
HMV01.1R	■	■	■ (!)	-	-	-	■ (!)	-
HMV02.1R	■	■	-	-	■ (!)	-	-	■ (!)

- allowed
- (!) must be used
- not allowed

Fig. 8-15: Additional components in the mains connection

## Configuration of the Drive System

## Mains Connection of HMV01.1E Supply Units

Supply unit	Mains chokes	Mains filter	Explanation	EMC limit value class to be achieved <sup>1)</sup> : max. leakage capacitance $C_{ab,g}$
HMV01.1E-W0030	HNL01.1E-0400-N0051	HNF01.1A-F240-E0051	standard combination up to <b>12 axes</b> (6 HMD01) motor cable lengths: 280 m ( $f_s = 8$ kHz) 110 m ( $f_s = 12$ kHz)	A1: 290 nF
	without	HNF01.1A-F240-E0051	reduced performance data; see Project Planning Manual	
	HNL01.1E-0400-N0051	HNF01.1A-M900-E0051	standard combination up to <b>21 axes</b> (11 HMD01) motor cable lengths: 1,050 m ( $f_s = 8$ kHz) 270 m ( $f_s = 12$ kHz)	A1: 1100 nF
	without	HNF01.1A-M900-E0051	reduced performance data; see Project Planning Manual	
	HNL01.1E-0400-N0051 with HNL01.1E-5700-S0051	customer-side	standard mains choke connected in series with current-compensated mains choke to reduce line-frequency leakage currents	
	without	without	not allowed	

## Configuration of the Drive System

Supply unit	Mains chokes	Mains filter	Explanation	EMC limit value class to be achieved <sup>1)</sup> : max. leakage capacitance $C_{ab\_g}$
HMV01.1E-W0075	HNL01.1E-0200-N0125	HNF01.1A-F240-E0125	standard combination up to <b>12 axes</b> (6 HMD01) motor cable lengths: 280 m ( $f_s = 8$ kHz) 110 m ( $f_s = 12$ kHz)	A2.2: 290 nF
	without	HNF01.1A-F240-E0125	reduced performance data; see Project Planning Manual	
	HNL01.1E-0200-N0125	HNF01.1A-M900-E0125	standard combination up to <b>21 axes</b> (11 HMD01) motor cable lengths: 1,050 m ( $f_s = 8$ kHz) 270 m ( $f_s = 12$ kHz)	A2.2: 1100 nF
	without	HNF01.1A-M900-E0125	reduced performance data; see Project Planning Manual	
	HNL01.1E-0200-N0125 with HNL01.1E-2800-S0125	customer-side	standard mains choke connected in series with current-compensated mains choke to reduce line-frequency leakage currents	
	without	without	standard combination for <b>1 axis</b> (1 HMD01) motor cable lengths: 40 m ( $f_s = 8$ kHz) 40 m ( $f_s = 12$ kHz)	A2.1: 40 nF

Configuration of the Drive System

Supply unit	Mains chokes	Mains filter	Explanation	EMC limit value class to be achieved <sup>1)</sup> : max. leakage capacitance $C_{ab,g}$
HMV01.1E-W0120	HNL01.1E-0100-N0202	HNF01.1A-F240-E0202	standard combination up to <b>12 axes</b> (6 HMD01) motor cable lengths: 280 m ( $f_s = 8$ kHz) 110 m ( $f_s = 12$ kHz)	A2.2: 290 nF
	without	HNF01.1A-F240-E0202	reduced performance data; see Project Planning Manual	
	HNL01.1E-0100-N0202	HNF01.1A-M900-E0202	standard combination up to <b>21 axes</b> (11 HMD01) motor cable lengths: 1,050 m ( $f_s = 8$ kHz) 270 m ( $f_s = 12$ kHz)	A2.2: 1100 nF
	without	HNF01.1A-M900-E0202	reduced performance data; see Project Planning Manual	
	HNL01.1E-0100-N0202 with HNL01.1E-3400-S0202	customer-side	standard mains choke connected in series with current-compensated mains choke to reduce line-frequency leakage currents	
	without	without	standard combination for <b>1 axis</b> (1 HMD01) motor cable lengths: 40 m ( $f_s = 8$ kHz) 40 m ( $f_s = 12$ kHz)	A2.1: 40 nF

<sup>1)</sup> in grounded mains  
 Fig. 8-16: Mains connection HMV01.1E



## Mains Connection of HMV01.1R Supply Units

Supply unit	Mains chokes	Mains filter	Explanation	EMC limit value class to be achieved <sup>1)</sup> : max. leakage capacitance $C_{ab-g}$
HMV01.1R-W0018	HNL01.1R-0980-C0026	HNF01.1A-F240-R0026	standard combination up to <b>12 axes</b> (6 HMD01) motor cable lengths: 280 m ( $f_s = 8$ kHz) 110 m ( $f_s = 12$ kHz)	A1: 290 nF
	HNL01.1R-0980-C0026	HNF01.1A-M900-R0026	standard combination up to <b>21 axes</b> (11 HMD01) motor cable lengths: 1,050 m ( $f_s = 8$ kHz) 270 m ( $f_s = 12$ kHz)	A1: 1100 nF
	HNL01.1R-0980-C0026 with HNL01.1R-4200-S0026	customer-side	standard mains choke connected in series with current-compensated mains choke to reduce line-frequency leakage currents	
HMV01.1R-W0045	HNL01.1R-0590-C0065	HNF01.1A-F240-R0065	standard combination up to <b>12 axes</b> (6 HMD01) motor cable lengths: 280 m ( $f_s = 8$ kHz) 110 m ( $f_s = 12$ kHz)	A1: 290 nF
	HNL01.1R-0590-C0065	HNF01.1A-M900-R0065	standard combination up to <b>21 axes</b> (11 HMD01) motor cable lengths: 1,050 m ( $f_s = 8$ kHz) 270 m ( $f_s = 12$ kHz)	A1: 1100 nF
	HNL01.1R-0590-C0065 with HNL01.1R-6300-S0065	customer-side	standard mains choke connected in series with current-compensated mains choke to reduce line-frequency leakage currents	

## Configuration of the Drive System

Supply unit	Mains chokes	Mains filter	Explanation	EMC limit value class to be achieved <sup>1)</sup> : max. leakage capacitance $C_{ab_g}$
HMV01.1R-W0065	HNL01.1R-0540-C0094	HNF01.1A-F240-R0094	standard combination up to <b>12 axes</b> (6 HMD01) motor cable lengths: 280 m ( $f_s = 8$ kHz) 110 m ( $f_s = 12$ kHz)	A2.2: 290 nF
	HNL01.1R-0540-C0094	HNF01.1A-M900-R0094	standard combination up to <b>21 axes</b> (11 HMD01) motor cable lengths: 1,050 m ( $f_s = 8$ kHz) 270 m ( $f_s = 12$ kHz)	A2.2: 1100 nF
	HNL01.1R-0540-C0094 with HNL01.1R-3000-S0094	customer-side	standard mains choke connected in series with current-compensated mains choke to reduce line-frequency leakage currents	
HMV01.1R-W0120	HNL01.1R-0300-C0180	HNF01.1A-H350-R0180	standard combination up to <b>8 axes</b> (4 HMD01) motor cable lengths: 350 m ( $f_s = 8$ kHz)	

<sup>1)</sup> in grounded mains  
Fig.8-17: Mains connection phase HMV01.1R

## Mains Connection of HMV02.1R Supply Units

Supply unit	Mains chokes	Mains filter	Explanation	EMC limit value class to be achieved <sup>1)</sup> : leakage capacitance $C_{ab_g}$
HMV02.1R-W0015	HNL02.1R-0980-C0023	HNS02.1A-Q200-R0023	standard combination up to <b>12 axes</b> motor cable lengths: 150 m ( $f_s = 8$ kHz)	A2.1

<sup>1)</sup> in grounded mains  
Fig.8-18: Mains connection phase HMV02.1R

### 8.3.3 Mains Connection for HCS Converters

#### Mains Connection for Converters - Overview

Converter	Transformer		Mains filter			Mains choke		
	DST (auto)	DLT (isolating)	NFD 03.1	HNF01.1*- ****-R****	HNF01.1*- ****-E****	HNK 01.1	HNL01.1E; HNL01.1E- ****-S	HNL01.1R; HNL01.1R- ****-S
HCS02.1E	■	■	■	■ <sup>1)</sup>	■ <sup>1)</sup>	-	■	-
HCS03.1E	■	■	-	■ <sup>1)</sup>	■ <sup>1)</sup>	■	■	-

■ allowed

- not allowed

1) observe the note "Minimum capacitance at the DC bus against ground required!"

Fig. 8-19: Additional components in the mains connection of converters



#### Minimum capacitance at the DC bus against ground required!

When using HNF01.1 mains filters at HCS02.1 and HCS03.1, make sure that the condition of minimum capacitances against ground is complied with at the DC bus of the combined system.

The minimum capacitance is **330 nF** against ground each at L+ and L-.

If the system does not achieve the minimum capacitance, use the accessory HAS04.

#### Accessory HAS04

Drive controllers already have capacitances  $C_Y$  against ground at L+ and L-.



See Project Planning Manual "Rexroth IndraDrive Supply Units and Power Sections" → Chapter of the respective device → "Technical Data" → "Mechanical System and Mounting" → "Dimensions, Mass, Insulation, Sound Pressure Level"

The integrated capacitances  $C_Y$  of HCS02 or HCS03 converters are not sufficient for operating HNF01 mains filters. In systems combined of several drive controllers, higher capacitances  $C_Y$  take effect. Use the HAS04 accessory depending on the involved components.

Drive controller	Capacitance $C_Y$ against ground in nF <sup>1)</sup>	Use of HAS04
HMS01.1N: < W0110	2 × 68	number of HMS01 ≤ 3
HMS01.1N: ≥ W0110	2 × 100	number of HMS01 ≤ 3
HMS02	2 × 68	number of HMS01 ≤ 3
HMD01	2 × 68	number of HMS01 ≤ 3
HCS02	2 × 100	number of HCS02 ≤ 4 check other combinations

### Configuration of the Drive System

Drive controller	Capacitance $C_Y$ against ground in nF <sup>1)</sup>	Use of HAS04
HCS03	2 × 100	number of HCS03 ≤ 4 check other combinations
KCU01	2 × 470	not required

<sup>1)</sup> see also documentation "Supply Units and Power Sections - Project Planning Manual"

Fig.8-20: Capacitances  $C_Y$ , capacitances at L+ and L- against ground

Accessory HAS04	For converter
HAS04.1-001 (2 × 470 nF)	HCS02
HAS04.1-002 (2 × 470 nF)	HCS03

Fig.8-21: Assignment HAS04 accessory

### Mains Connection for HCS02 Converters



With HCS02.1E drive controllers, the **limit value class A2.1** (see "Limit Values for Line-Based Disturbances") can already be achieved in grounded mains **without using mains filters**.

Observe notes in chapter 11 [Arranging the Components in the Control Cabinet](#), page 145.

Converter	Mains chokes	Mains filter	Explanation	EMC limit value class to be achieved <sup>2)</sup> : max. leakage capacitance $C_{ab_g}$
HCS02.1E-W0012	HNL01.1E-1000-N0012 (optional)	NFD03.1-480-007	standard combination for <b>1 converter</b> motor cable length: 75 m ( $f_s = 4$ kHz)	A2.1
	HNL01.1E-1000-N0020	NFD03.1-480-016	group supply up to <b>6 HCS02</b> motor cable lengths: 120 m ( $f_s = 8$ kHz)	A2.2: 60 nF A1: 50 nF B1: 40 nF
HCS02.1E-W0028	HNL01.1E-1000-N0012 (optional)	NFD03.1-480-016	standard combination for <b>1 converter</b> motor cable length: 75 m ( $f_s = 4$ kHz)	A2.1
	HNL01.1E-0600-N0032	NFD03.1-480-030	group supply up to <b>6 HCS02</b> motor cable lengths: 120 m ( $f_s = 8$ kHz)	A2.2: 80 nF A1: 50 nF

## Configuration of the Drive System

Converter	Mains chokes	Mains filter	Explanation	EMC limit value class to be achieved <sup>2)</sup> : max. leakage capacitance $C_{ab\_g}$
HCS02.1E-W0054	HNL01.1E-1000-N0020	NFD03.1-480-030	standard combination for <b>1 converter</b> motor cable length: 75 m ( $f_s = 4$ kHz)	A2.1
	HNL01.1E-1000-N0020	NFD03.1-480-030	central supply up to <b>6 axes</b> motor cable lengths: 120 m ( $f_s = 8$ kHz)	A2.2: 80 nF A1: 50 nF
	HNL01.1E-1000-N0020	NFD03.1-480-055	central supply up to <b>6 axes</b> motor cable lengths: 120 m ( $f_s = 8$ kHz)	A2.2: 110 nF A1: 70 nF B1: 55 nF
	HNL01.1E-1000-N0020	HNF01.1A-F240-R0026 <sup>1)</sup>	central supply up to <b>6 axes</b> motor cable lengths: 240 m ( $f_s = 8$ kHz)	A2.2: 350 nF A1: 300 nF B1: 89 nF
	HNL01.1E-1000-N0020	HNF01.1A-M900-R0026 <sup>1)</sup>	central supply up to <b>12 axes</b> motor cable lengths: 900 m ( $f_s = 8$ kHz)	A2.2: 350 nF
	HNL01.1E-1000-N0020	HNF01.1A-M900-E0051 <sup>1)</sup>	central supply up to <b>12 axes</b> motor cable lengths: 900 m ( $f_s = 8$ kHz)	A2.2: 350 nF A1: 350 nF B1: 350 nF
HCS02.1E-W0070	HNL01.1E-0600-N0032	NFD03.1-480-055	standard combination for <b>1 converter</b> motor cable length: 75 m ( $f_s = 4$ kHz)	A2.1
	HNL01.1E-0600-N0032	NFD03.1-480-055	central supply up to <b>6 axes</b> motor cable lengths: 120 m ( $f_s = 8$ kHz)	A2.2: 100 nF A1: 70 nF B1: 52 nF
	HNL01.1E-0600-N0032	NFD03.1-480-075	central supply up to <b>6 axes</b> motor cable lengths: 120 m ( $f_s = 8$ kHz)	A2.2: 110 nF A1: 70 nF B1: 55 nF
	HNL01.1E-0600-N0032	HNF01.1A-M900-E0051 <sup>1)</sup>	central supply up to <b>12 axes</b> motor cable lengths: 900 m ( $f_s = 8$ kHz)	A2.2: 350 nF

1) use HAS04.1-002

2) in grounded mains

Fig. 8-22: Mains connection HCS02

## Configuration of the Drive System

## Mains Connection for HCS03 Converters

Converter	Mains chokes	Mains filter	Explanation
HCS03.1E- W0070	HNK01.1A-A075-E0050		standard combination for <b>1 converter</b> motor cable length: 75 m ( $f_s = 4$ kHz)
	HNL01.1E-0571-N0050		standard for operating one drive controller without mains filter
	HNL01.1E-0571-N0050	HNF01.1A-F240-E0051 <sup>1)</sup>	central supply up to <b>6 axes</b> (2 HMD01) motor cable lengths: 240 m ( $f_s = 8$ kHz)
	HNL01.1E-0571-N0050	HNF01.1A-M900-E0051 <sup>1)</sup>	central supply up to <b>12 axes</b> (5 HMD01) motor cable lengths: 900 m ( $f_s = 8$ kHz)
	HNL01.1E-0400-N0051 with HNL01.1E-5700-S0051	customer-side	standard mains choke connected in series with current-compensated mains choke to re- duce line-frequency leakage currents
HCS03.1E- W0100	HNK01.1A-A075-E0080		standard combination for <b>1 converter</b> motor cable length: 75 m ( $f_s = 4$ kHz)
	HNL01.1E-0362-N0080		standard for operating one drive controller without mains filter
	HNL01.1E-0362-N0080	HNF01.1A-F240-E0125 <sup>1)</sup>	central supply up to <b>6 axes</b> (2 HMD01) motor cable lengths: 240 m ( $f_s = 8$ kHz)
	HNL01.1E-0362-N0080	HNF01.1A-M900-E0125 <sup>1)</sup>	central supply up to <b>12 axes</b> (5 HMD01) motor cable lengths: 900 m ( $f_s = 8$ kHz)
	HNL01.1E-0362-N0080 with HNL01.1E-2800-S0125	customer-side	standard mains choke connected in series with current-compensated mains choke to re- duce line-frequency leakage currents

## Configuration of the Drive System

Converter	Mains chokes	Mains filter	Explanation
HCS03.1E-W0150	HNK01.1A-A075-E0106		standard combination for <b>1 converter</b> motor cable length: 75 m ( $f_s = 4$ kHz)
	HNL01.1E-0240-N0106	without	standard for operating one drive controller without mains filter
	HNL01.1E-0240-N0106	HNF01.1A-F240-E0125 <sup>1)</sup>	central supply up to <b>6 axes</b> (2 HMD01) motor cable lengths: 240 m ( $f_s = 8$ kHz);
	HNL01.1E-0240-N0106	HNF01.1A-M900-E0125 <sup>1)</sup>	central supply up to <b>12 axes</b> (5 HMD01) motor cable lengths: 900 m ( $f_s = 8$ kHz)
	HNL01.1E-0240-N0106 with HNL01.1E-2800-S0125	customer-side	standard mains choke connected in series with current-compensated mains choke to re- duce line-frequency leakage currents
HCS03.1E-W0210	HNK01.1A-A075-E0146		standard combination for <b>1 converter</b> motor cable length: 75 m ( $f_s = 4$ kHz)
	HNL01.1E-0170-N0146	without	standard for operating one drive controller without mains filter
	HNL01.1E-0170-N0146	HNF01.1A-F240-E0202 <sup>1)</sup>	central supply up to <b>6 axes</b> (2 HMD01) motor cable lengths: 240 m ( $f_s = 8$ kHz)
	HNL01.1E-0170-N0146	HNF01.1A-M900-E0202 <sup>1)</sup>	central supply up to <b>12 axes</b> (5 HMD01) motor cable lengths: 900 m ( $f_s = 8$ kHz)
	HNL01.1E-0170-N0146 with HNL01.1E-3400-S0202	customer-side	standard mains choke connected in series with current-compensated mains choke to re- duce line-frequency leakage currents

<sup>1)</sup> use HAS04.1-002  
Fig. 8-23: Mains connection HCS03

## 8.4 Additional Components

### 8.4.1 Additional Components at the DC Bus

#### General Information

Converters and supply units basically differ in the following features:

- braking resistor integrated
- possible connection for external HLR braking resistor
- operation of DC bus resistor unit HLB
- operation of DC bus capacitor unit HLC

#### Allowed Combinations

The table below shows which additional components are allowed at the DC bus of HMV supply units and HCS converters.



Configuration of the Drive System

Supply unit or converter	HLB01.1C	HLB01.1D	HLC01.1C	HLC01.1D	HLR01.1
HMV01.1E	-	■	■ <sup>2)</sup>	■	-
HMV01.1R	-	■	■ <sup>2)</sup>	■	-
HMV02.1R	■	-	■	-	-
HCS02.1	■	■ <sup>2)</sup>	■	■ <sup>2)</sup>	■ <sup>3)</sup>
HCS03.1	-	■	-	■ <sup>1)</sup>	■ <sup>4)</sup>

- allowed
- not allowed
- 1) only HCS03.1E-...-W0210
- 2) different mounting depths: control cabinet adapter HAS03 required
- 3) HCS02.1E-W0054, -W0070 (standard equipment: braking transistor integrated)
- 4) HCS03.1E in optional design -xxBx (integrated braking transistor) required

Fig.8-24: Combinations with additional components



**HCS03.1 with HLC01**

In the HCS03 product line, it is allowed to operate external capacitances at the DC bus for the HCS03.1E-W0210 type.



Observe the data  $C_{DCext}$  in the Project Planning Manual "Rexroth IndraDrive Supply Units and Power Sections" → "HCS03 Power Sections" → "Technical Data" → "Basic Data" → Data of power section - DC bus

Notes on Project Planning for HLR Braking Resistors



**CAUTION**

**High temperatures in the proximity of braking resistors!**

Mount the braking resistors to temperature-resistant mounting surfaces in such a way that the air can freely enter and escape and heat does not accumulate.

Take the minimum distances  $d_{top}$ ,  $d_{bot}$  and  $d_{hor}$  into account.

Take into account that the temperatures in the range of the indicated minimum distances can be above 250 °C.

Leave sufficient distance to combustible objects and take into account that braking resistors dissipate a lot of heat.

Make sure there is free cooling air supply at the bottom  $d_{bot}$  and cooling air discharge at the top  $d_{top}$ .

The space must be able to discharge the energy converted by the braking resistor.

## Orientation guide for selecting additional components HLR, HLB

Criterion	DC bus resistor units HLB	Braking resistor HLR
regenerative operation with great energy contents, e.g. <ul style="list-style-type: none"> <li>deceleration of great centrifugal masses at centrifuges</li> <li>long braking processes for crane lifting gears</li> </ul>	□ take energy absorption capacity and continuous power into account	■ type of construction N check use of HMVxx.xR
kinetic energy is generated in control cabinet and can be dissipated	■	□ type of construction A
kinetic energy cannot be dissipated in control cabinet	-	■ type of construction N observe degree of protection
quick discharge of DC bus required DC bus short circuit device	■	-
deceleration of synchronous motors in the case of error "mains failure"	■	-
supply unit HMV01.1R-W0120	■	-
converter HCS02 selected	■	■
converter HCS03 selected	■	■ option -xxBx required

- recommended  
□ suited to a limited extent  
- not allowed

Fig. 8-25: Orientation guide



## Required type data

To select an appropriate HLR braking resistor, the following type data of the application are required:

- peak regenerative power  $P_{RS, Anlage}$
- continuous regenerative power  $P_{RD, Anlage}$
- regenerative power  $W_{R, Anlage}$

For calculating the type data, see chapter [16.1 Determining the Appropriate Drive Controller](#), page 319.



## HCS02, HCS03 with HLR01 and simultaneously HLB01

- The continuous power of the selected HLR01 has to be at least as high as the continuous power of the HLB used.
- Due to differences in balance, the total continuous power is lower than the sum of the individual continuous powers. The balancing factor of 0.8 is regarded as the guide value.

Configuration of the Drive System



**Function of integrated braking resistor in HCS02 for operation with HLR01**

Braking resistors have been integrated in HCS02 drive controllers. When operating external HLR01 braking resistors, the integrated braking resistors are not loaded.

See also parameter

- P-0-0859, Data of internal braking resistor
- P-0-0860, Converter configuration



**Observe degree of protection!**

When mounted outdoor or at the outside of the control cabinet, observe the degree of protection IP20 of the braking resistor.

Protect the devices against intrusion of water.



**Protection against overload!**

The HCS drive controller monitors the external braking resistor by means of the firmware which calculates a thermal image of the current braking power. When the limit values for the thermal image are exceeded, the converter switches off with the error "F8820 Braking resistor overload" to protect the braking resistor against overload.

- Exclusively operate the combinations of converter - braking resistor type listed below.
- At the drive controllers HCS02 and HCS03, parameterize the performance data of the selected braking resistor in parameter "P-0-0858, Data of external braking resistor". For this purpose, from the technical data take the data on: resistance value, braking resistor continuous power and maximum regenerative power to be absorbed.
- Activate the selected braking resistor by setting, in parameter "P-0-0860, Converter configuration", bit 8 = 1.

**Braking Resistors HLR01 for HCS02**

Converter	Braking resistor type <sup>1)</sup>	Type of construction <sup>2)</sup>	Type Dimensions <sup>3)</sup>
HCS02.1E-W0054-A-03-xNNx	HLR01.1N-01K8-N40R0-...	N for free assembly	A7
HCS02.1E-W0054-A-03-xNNx	HLR01.1N-03K8-N40R0-...	N for free assembly	B1
HCS02.1E-W0070-A-03-xNNx	HLR01.1N-02K4-N28R0-...	N for free assembly	A8
HCS02.1E-W0070-A-03-xNNx	HLR01.1N-05K5-N28R0-...	N for free assembly	B2

- 1) complete type with: A-007-NNNN
- 2) see Project Planning Manual "Rexroth IndraDrive Additional Components", type code HLR
- 3) see Project Planning Manual "Rexroth IndraDrive Additional Components", dimensions tables HLR

Fig. 8-26: Assignment braking resistors HLR - HCS02

## Configuration of the Drive System

Braking Resistors HLR01 for  
HCS03

Converter	Braking resistor type <sup>1)</sup>	Type of construction <sup>2)</sup>	Type Dimensions <sup>3)</sup>
HCS03.1E-W0070-A-05-xNBV	HLR01.1A-0300-N17R5-...	A for device mounting	see corresponding dimensional drawing HLR01.1N-...
HCS03.1E-W0100-A-05-xNBV	HLR01.1A-0470-N11R7-...	A for device mounting	
HCS03.1E-W0150-A-05-xNBV	HLR01.1A-0780-N07R0-...	A for device mounting	
HCS03.1E-W0210-A-05-xNBV	HLR01.1A-1K08-N05R0-...	A for device mounting	
HCS03.1E-W0070-A-05-xNBV	HLR01.1N-01K6-N18R0-...	N for free assembly	A5
HCS03.1E-W0100-A-05-xNBV	HLR01.1N-02K0-N15R0-...	N for free assembly	A6
HCS03.1E-W0150-A-05-xNBV	HLR01.1N-04K5-N07R4-...	N for free assembly	B1
HCS03.1E-W0210-A-05-xNBV	HLR01.1N-06K5-N06R1-...	N for free assembly	B2
HCS03.1E-W0070-A-05-xNBV	HLR01.1N-03K5-N19R0-...	N for free assembly	B1
HCS03.1E-W0100-A-05-xNBV	HLR01.1N-05K0-N15R0-...	N for free assembly	B2
HCS03.1E-W0150-A-05-xNBV	HLR01.1N-08K5-N08R0-...	N for free assembly	B3
HCS03.1E-W0210-A-05-xNBV	HLR01.1N-12K5-N05R5-...	N for free assembly	B4
HCS03.1E-W0070-A-05-xNBV	HLR01.1N-04K5-N18R0-...	N for free assembly	B2
HCS03.1E-W0100-A-05-xNBV	HLR01.1N-07K0-N14R0-...	N for free assembly	B3
HCS03.1E-W0150-A-05-xNBV	HLR01.1N-11K0-N07R3-...	N for free assembly	B3
HCS03.1E-W0210-A-05-xNBV	HLR01.1N-17K0-N05R1-...	N for free assembly	B5
HCS03.1E-W0070-A-05-xNBV	HLR01.1N-06K5-N18R0-...	N for free assembly	B2
HCS03.1E-W0100-A-05-xNBV	HLR01.1N-09K5-N13R0-...	N for free assembly	B3
HCS03.1E-W0150-A-05-xNBV	HLR01.1N-15K0-N08R1-...	N for free assembly	B4

Configuration of the Drive System

Converter	Braking resistor type <sup>1)</sup>	Type of construction <sup>2)</sup>	Type Dimensions <sup>3)</sup>
HCS03.1E-W0210-A-05-xNBV	HLR01.1N-23K0-N05R5-...	N for free assembly	C2
HCS03.1E-W0070-A-05-xNBV	HLR01.1N-10K0-N18R0-...	N for free assembly	B3
HCS03.1E-W0100-A-05-xNBV	HLR01.1N-14K5-N13R0-...	N for free assembly	B4
HCS03.1E-W0150-A-05-xNBV	HLR01.1N-24K0-N07R2-...	N for free assembly	C3
HCS03.1E-W0210-A-05-xNBV	HLR01.1N-36K0-N05R4-...	N for free assembly	C4

- 1) complete type with: A-007-NNNN
- 2) see Project Planning Manual "Rexroth IndraDrive Additional Components", type code HLR
- 3) see Project Planning Manual "Rexroth IndraDrive Additional Components", dimensions tables HLR

Fig. 8-27: Assignment braking resistors HLR - HCS03

## 8.4.2 Additional Components at the Motor Output

### General Information

In conjunction with long motor cables, the steep switching edges at the motor output of the drive controllers can cause transient overvoltages and high rise of voltage at the motor.

### Motor Filters HMF01



CAUTION

#### Damage caused by too high switching frequency!

Only operate HMF01 motor filters up to the maximum allowed switching frequency  $f_s$  of 4 kHz.

Motor filter HMF01	Drive controller
HMF01.1A-N0K2-M0012	HCS02.1E-W0012
HMF01.1A-N0K2-M0028	HCS02.1E-W0028
HMF01.1A-N0K2-D0045-...	HCS03.1E-W0070
HMF01.1A-N0K2-D0073-...	HCS03.1E-W0100
HMF01.1A-N0K2-D0095-...	HCS03.1E-W0150
HMF01.1A-N0K2-D0145-...	HCS03.1E-W0210

Fig. 8-28: Assignment HMF01 to HCS03

## 8.5 Control Section and Firmware for Drive Controllers

### 8.5.1 General Information

The modular structure of the IndraDrive controllers allows a multitude of combinations of control sections and drive controllers. Depending on the firmware design, the firmware of the Rexroth IndraDrive product range supports the combinations of control section and power section listed below.

## Configuration of the Drive System

## Allowed Combination Control Section - Firmware

Control section	Firmware		
	MPB	MPH	MPD
CSH01.1-C <sup>1)</sup>	-	■	-
CSH01.2-C <sup>1)</sup>	-	■	-
CSB01.1-N <sup>2)</sup>	■	-	-
CSB01.1-C <sup>1)</sup>	■	-	-
CDB01.1-C <sup>1)</sup>	-	-	■

■ allowed

- not allowed

1) control section can be configured

2) control section cannot be configured

Fig. 8-29: Combination control section - firmware

## Allowed Combination Control Section - Power Section

Power Section	HMS01	HMS02	HMD01	HCS02	HCS03
Control section					
CSH01.1-C <sup>1)</sup>	■	■	-	■	■
CSH01.2C <sup>1)</sup>	■	■	-	■	■
CSB01.1-N <sup>2)</sup>	■	■	-	■	■
CSB01.1-C <sup>1)</sup>	■	■	-	■	■
CDB01.1-C <sup>1)</sup>	-	-	■	-	-

■ allowed

- not allowed

1) control section can be configured

2) control section cannot be configured

Fig. 8-30: Combination control section - power section



The control section of a drive controller mustn't be mounted and dismounted more than a maximum of 20 times. If this number is exceeded, the electrical data of the internal connection can be above the specified minimum requirements. This can cause malfunction of the drive controllers.

## 8.5.2 Required Equipment of Control Sections With Optional Modules for Evaluating Encoder Systems

The control sections of the Rexroth IndraDrive product range support different encoder systems. The table below shows the assignment of the encoder system to the required equipment of the control section with options.



Operating other encoder systems than the ones listed above requires detailed control of the technical data of the encoder system used and the interface specification of the control section.

When using third-party encoders, observe that the optional modules provide different supply voltages.

Configuration of the Drive System

Encoder system <sup>1)</sup>	Brief description of encoder system (informal)	Optional module encoder evaluation			Cable for direct connection <sup>2)</sup>
		ENS	EN1	EN2	
R0	resolver	-	■	-	IKS4043
R1	resolver with integrated absolute multi-turn encoder	-	■	-	IKS4043
S0	optical encoder single-turn IIC, 512 increments, supply voltage 8 V	-	■	-	IKS4042
S1	optical encoder single-turn HIPERFACE, 128 increments, supply voltage 7...12 V	■	-	-	RKG4200
S2	optical encoder single-turn EnDat2.1, 2048 increments, supply voltage 12 V	■	-	-	RKG4200
M0	optical encoder multi-turn absolute IIC, 512 increments, supply voltage 8 V	-	■	-	IKS4042
M1	optical encoder multi-turn absolute HIPERFACE, 128 increments, supply voltage 7 ... 12 V	■	-	-	RKG4200
M2	optical encoder multi-turn absolute EnDat2.1, 2048 increments, supply voltage 12V	■	-	-	RKG4200
C0	optical encoder incremental 1 V <sub>pp</sub> , 2048 increments (sin/cos)	-	-	■	RKG0014
SHL01.1	Hall sensor box for position detection of primary part of, for example, IndraDyn L and LSF motors	-	■ <sup>3)</sup>	-	IKS4042
SHL02.1 (preliminary data)	Hall sensor box for position detection of primary part of, for example, IndraDyn L and LSF motors	-	■ <sup>4)</sup>	-	IKS4042
		■	-	-	RKG0027
<b>Rexroth ServoDyn D servo motors SF</b>					
STG	single-turn encoder, absolute			■	RKG0015
MTG	multi-turn encoder, 4096 revs. absolute			■	RKG0015
<b>Rexroth ServoDyn D servo motors SR</b>					
	resolver	-	-	-	-

- allowed
- not allowed
- 1) see note below
- 2) without extension and control cabinet duct
- 3) up to MPx04VRS, only allowed on option 2 (X8)
- 4) up to MPx04VRS, only allowed on option 2 (X8); as of MPx05VRS configurable

Fig. 8-31: Combination control section equipment - motor encoder



For the kind of encoder system, see the type code of the selected motor.



Abbrev.	Column	2	3	4	5	6	7	8	9	1	2	3	4	5	6	7	8	9	2	1	2	3	4	5	6	7	8	9		
Example:		M	S	K	0	7	0	C	-	0	4	5	0	-	N	N	-	S	1	-	U	G	0	-	N	N	N	N		

6. Encoder	
6.1	Optical encoder, singleturn hipurface, with 128 increments ..... = S1
6.2	Optical encoder, singleturn EnDat2.1, with 2048 increments ..... = S2
6.3	Optical encoder, multiturn-absolute hipurface, with 128 increments ..... = M1
6.4	Optical encoder, multiturn-absolute EnDat2.1, ..... = M2

DT000002v01\_en.fh11

Fig.8-32: Type code section of motor

## 8.6 Combination with Other Rexroth Components

### 8.6.1 Combination with Components of the Control Range Rexroth IndraControl V

#### Operator Terminals VCP

The VCP operator terminals allow comfortable operation of the Rexroth IndraDrive drive system with the IndraControl V control range.

The operator terminals VCP02, VCP05, VCP08, VCP20 and VCP25 are suited for control cabinet mounting and operated via the serial interface RS232 (X2) of the control sections.

The comfort control panel VCP01 is operated directly at the drive controller at the connection "H1". It then replaces the supplied standard control panel. The scope of functions is described in the Operating Instructions "Rexroth IndraDrive C Drive Controllers HCS02.1, HCS03.1".



Simultaneous operation of VCP operator terminals and standard control panels or comfort control panels is allowed.

### 8.6.2 SERCOS Analog Converter

#### General Information

To modernize machines the drive range Rexroth IndraDrive provides the possibility of operating drive controllers of the "ANAX" and "DiAx 02" ranges with analog command value input.

#### SERCOS Analog Converter

The SERCOS analog converter is used to

- connect control units with SERCOS interface to components with analog interface
- convert SERCOS position command values to analog speed command values

The SERCOS analog converter consists of:

- housing for **HAC01.1-002** control sections
- configurable control section with SERCOS master communication
  - for MAC motors at TDM drive controllers:
    - BASIC CDB01.1C-SE-EN1-EN1-MA1-MA1--NN-S-NN-FW

## Configuration of the Drive System

- for MDD motors at DDS drive controllers:  
BASIC CDB01.1C-SE-EN2-EN2-MA1-MA1--NN-S-NN-FW
- BASIC CDB01.1C-SE-ENS-ENS-MA1-MA1-NN-S-NN-FW (preliminary)
- firmware e.g. FWA-INDRV\*-MPD-04VRS-\*\*-\*\*\*-\*\*-\*\*
- optional accessory **HAS01.1-065-NNN-CN**



Make sure that parameter "P-0-0860, Converter configuration" has been set to operation as "SERCOS analog converter" (bit 15 = 1). Wrong setting will generate the error message "F8091 Power section defective".

## 8.7 Connection Cables to Motor

### 8.7.1 General Information

The connection from drive controller to motor is established by means of two cables:

- motor cable (power cable)
- encoder cable

The motor cable contains lines to connect the drive controller

- to the motor windings
- to the motor holding brake
- to the temperature measurement system of the motor

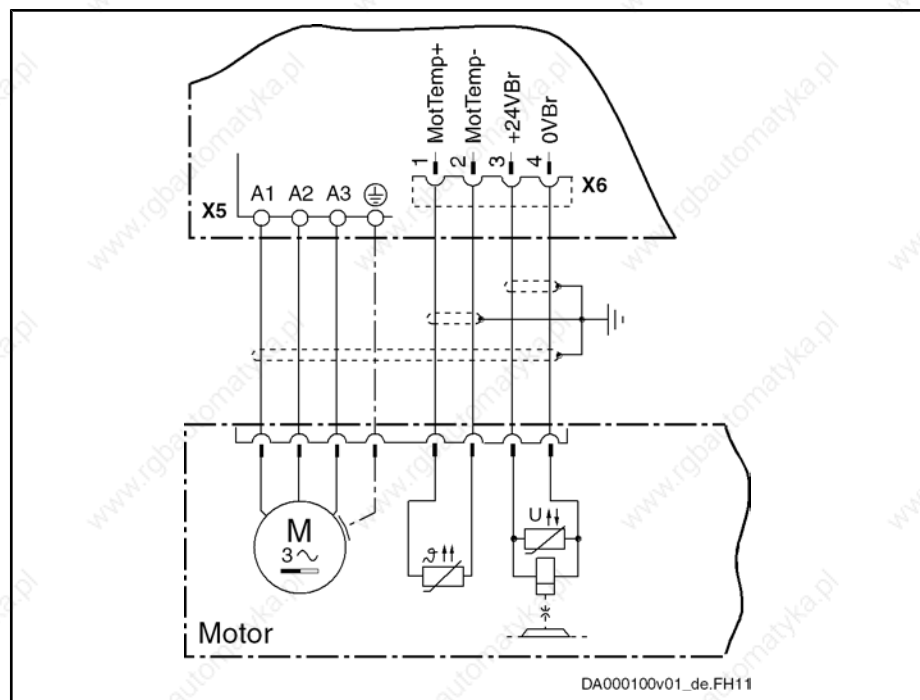

Fig.8-33: Power cable to connect drive controller to motor



Use shielded motor cables of the RKL line for Rexroth IndraDrive systems.



For selecting the motor cables and other connections (e.g. encoder cables), use the documentation "Rexroth Connection Cables - Selection Data".

## 8.7.2 Motor Cables

### General Information

For projecting and selecting the motor cable, observe the following aspects:

- required **cross section** depends on occurring loading with continuous current and peak current  
allowed **length** depends on PWM frequency, output filter and shielding
- length due to **voltage drop** on connection line to motor brake
- other **mechanical requirements** resulting from use of motor cable, such as bending radiuses, material compatibility; see documentation "Rexroth Connection Cables - Selection Data".

### Required Cross Section



To find the appropriate cable for the selected combination of motor and drive controller, see documentation "Rexroth Connection Cables - Selection Data".

### Allowed Length of Motor Cable

The length of the motor power cable is limited to protect the drive controllers. The longer the motor cable and the higher the switching frequency  $f_s$  of the drive controller which has been set, the higher the occurring losses.



Observe that the allowed motor cable length depends on the switching frequency  $f_s$  of the power output stage which has been set. As a matter of principle, the higher the switching frequency, the shorter the allowed cable length (to protect the drive controllers against overload).

Only set such switching frequencies which are supported by the involved components! Observe the technical data for drive controllers and motors.

See also Parameter Description "P-0-0001, Switching frequency of the power output stage".

Allowed cable lengths at ambient temperature  $T_{a\_work} \leq 40 \text{ °C}$  according to EN 60 204:

PWM frequency / kHz	Allowed cable length / m		
	without output filter		with output filter <sup>3)</sup>
	shielded	unshielded <sup>1)</sup>	
2 <sup>2)</sup>	100	175	200
4	75	150	200
8	38	150	not allowed

## Configuration of the Drive System

PWM frequency / kHz	Allowed cable length / m		
	12	25	not allowed
16	18	not allowed	not allowed

- 1) only allowed for HCS drive controllers, see also note below "Unshielded motor cables"
  - 2) depending on the drive controller which is used
  - 3) additional components HMF or HML
- Fig. 8-34: Line lengths*

**Unshielded motor cables**

Operation with unshielded motor cables

- aims at applications with "sensorless operation" (open-loop operation)
- does not include the control voltage lines to the motor; brake supply and evaluation of the temperature sensors in the motor might possibly require further measures
- requires additional measures with regard to EMC on the part of the operating company



For lines **connected in parallel**, half the indicated lengths apply.

**Voltage Drop on Connection to Motor Holding Brake**

The motor holding brake is controlled via the drive controller. For this purpose, the 24V supply is connected to the output at the connection point X6. To operate the motor holding brake reliably, observe its requirements on voltage supply.

For operating the integrated motor holding brakes of the motor line Rexroth IndraDyn at Rexroth IndraDrive controllers with Rexroth connection cables, the data of 24V supply are considered as guide values.



For the data of 24V supply, see Project Planning Manual "Rexroth Indra-Drive Supply Units and Power Sections" → Chapter of the respective device → "Technical Data" → "Basic Data" → "Data for control voltage supply".

**Mechanical Requirements**

Depending on the application, there are different requirements.



See the technical data of the cables in the documentation "Rexroth Connection Cables - Selection Data" for whether the properties comply with the requirements.

**Third-Party Power Cables**

Requirements on third-party motor power cables:

Maximum allowed **cable length** at A1, A2, A3:

- see chapter [8.7 Connection Cables to Motor, page 106](#)

Maximum allowed **capacitance per unit length** at A1, A2, A3:

- against ground, each: 0.5 nF/m
- against each other: 0.5 nF/m

Maximum allowed **inductance per unit length** at A1, A2, A3:

- 100 nH/m each



If you use third-party motor cables not corresponding to the requirements, Rexroth's guarantee for the drive system will expire. Use ready-made Rexroth cables.



To select the cables, use the documentation "Rexroth Connection Cables - Selection Data".

### 8.7.3 Encoder Cables



To select the cables, use the documentation "Rexroth Connection Cables - Selection Data".

## 8.8 Using Rexroth IndraDyn Motors

### 8.8.1 Rexroth IndraDyn H – Frameless Synchronous Spindle Motors

When selecting the drive controllers and supply units, make sure that, when using **MBS** motors, the occurring peak power does not cause overvoltage in the DC bus.

Therefore, make sure for your selection that the developed peak power of the motor is smaller than the peak power (or sum of peak powers) of the braking resistors at the DC bus. Take into account that, in particular during operation in the field weakening range, high peak powers occur when control voltage fails.

The assignment table below shows the supply units or drive controllers basically suited for operating MBS motors.

Drive controller or supply unit	IndraDyn H	Notes
	MBS	
HMV01	■	
HMV02	■	
HCS02	-	capacity $P_{BS}$ of braking resistor is too low for occurring peak power
HCS03	■	

■ allowed  
- not allowed  
*Fig. 8-35: Combinations*





## 9 Control Circuits for the Mains Connection

### 9.1 General Information

The controls of mains contactor and DC bus short circuit for supply units and drive controllers suggested in this documentation describe the **functional principles**.



The selection of the control and its effects depend on the extent of the functions and the operating sequence of the installation or machine. The selection of the control falls to the installation or machine manufacturer's responsibility.

### 9.2 Mains Contactor, Bb Contact

The central components in the control circuit for the mains connection are:

- mains contactor
- Bb contact

#### Mains Contactor

Mains contactors in the power circuit of the mains connection switch the power supply. In the case of error, mains contactors interrupt the energy flow from the supply mains and therewith the power supply of the drive controllers.

When the drive system is supplied via another circuit, e.g. in regenerative form via **permanently** driven motor:

- Integrate this supply in the control circuit for the mains connection.
- Take this into account when selecting the drive controllers and additional components.



#### Risk of fire caused by the "sacrificing behavior" of the ZKS stage!

The "ZKS" input activates the function "DC bus short circuit", when there hasn't any voltage been applied and when there isn't any current flowing to the input. This status occurs both in the case of wire break and when the 24V supply fails.

When the 24V supply fails in applications in which energy does not only get to the DC bus via the mains connection, but also via regeneratively operated motors (e.g. following-on rollers), the ZKS stage converts this energy into heat until it is destroyed ("sacrificing behavior").

Counter measures with such applications:

- Do not use drive controllers with integrated ZKS stage or
- buffer the 24V supply (e.g. by means of a UPS) to evaluate the monitor and switch off the energy flow in the case of error.

Switching off the power supply protects the supply units and drive controllers against permanently present error states and damage being caused by the persistent effect of these error states.

The **mains contactor does not replace overcurrent protection devices connected in the incoming circuit**, but is a functional complement. The mains contactor itself needs overcurrent protection to allow reliably operating it after switch-off processes.

In conjunction with the corresponding "control circuit for the mains connection", the mains contactor only switches the DC bus voltage to the drive controllers when they are ready to consume power voltage and when there isn't any error present.



## Control Circuits for the Mains Connection

In order that the drive controllers can signal their status, they must be supplied with the 24V control voltage.

The following scenarios are typical cases in which the control circuit for the mains connection is to switch off the mains contactor and lead to the power supply being switched off:

- short circuit at the output of the inverters with error "F8060 Overcurrent in power section"
- switch-on upon activated DC bus short circuit (ZKS) with error message "F2820 Braking resistor overload"
- operation at mains voltages outside of the allowed range with error message "F2815 Overvoltage in mains"

See also Troubleshooting Guide of the firmware used.

**Bb Contact** The mains contactor has to be controlled depending on the error status of the supply unit or drive controller.

At the control section of the HCS drive controllers and at the supply units, there is an isolated contact available for this purpose (relay contact Rel1) that has been configured as Bb contact in the condition as supplied. When the Bb contact closes, the drive or drive system is ready for power on.



For detailed information on the Bb contact, see Project Planning Manual "Rexroth IndraDrive Drive Controllers Control Sections".



**CAUTION**

### Danger of consequential damage!

Make sure that the mains contactor interrupts power supply from the mains when the Bb contact opens.



#### Load of Bb Contact

Observe the load capability limits of the Bb contact (see Project Planning Manual "Rexroth IndraDrive Control Sections" for the control section used [connection point X31.1, X31.2]).

Control contactors with AC excitation and contactors exceeding the load capability limits of the involved contact elements (Bb contacts etc.) via contactor relays.



See also Functional Description of firmware:Power Supply



#### Suppressor circuit for contactor coil

When the mains contactor is switched off, the contactor coil causes overvoltages. These overvoltages may result in premature failure of the Bb contact. To attenuate overvoltages, use overvoltage limiters with diode combination.

Varistors and RC elements are not allowed as suppressor circuit. Varistors are subject to aging and increase their reverse currents. RC elements overload the switching capacity of the Bb contact. This results in premature failure of the connected components and devices.

## Control Circuits for the Mains Connection

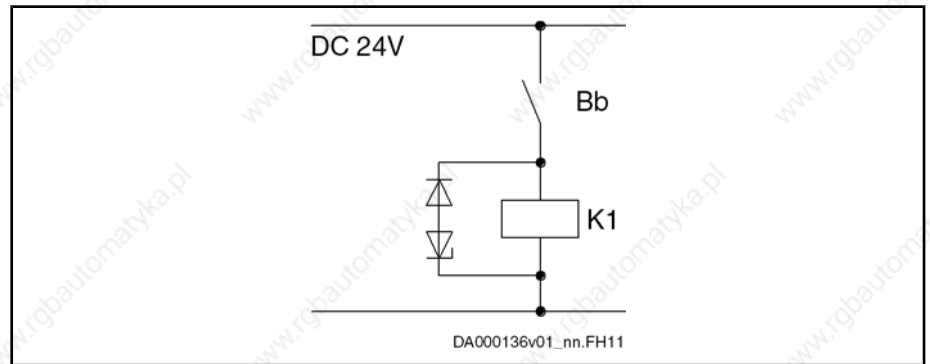

Fig. 9-1: Recommended suppressor circuit

**Switching on the Power Supply**

Switch-on sequence:

1. apply 24V control voltage
2. wait for readiness for operation of the connected components
3. switch on power supply (e.g. close mains contactor)

**Switching off the Power Supply**

Switch-off sequence:

1. switch power supply off
2. if required, switch 24V control voltage off

**Using and Arranging the Mains Contactor**

For HCS drive controllers of the Rexroth IndraDrive C product range, use an external mains contactor in the main connection for the control circuit. Connect the mains contactor electrically between mains filter and mains input (connection X3)<sup>1)</sup>.

The HMV01.1 supply units of the Rexroth IndraDrive M range have an integrated mains contactor<sup>2)</sup>.

**Lethal injuries caused by live parts with more than 50 V!**

Design and install the mains connection according to the valid standards.

Observe the protection goals

- electrical safety
- mechanical safety with incorrect movements
- protection against fire

Make sure you can provide evidence of the mechanisms of protection by means of FMEA and hazard analysis.

<sup>1)</sup> Exception: When using HNK01 at HCS03, it is allowed to connect the mains contactor electrically before HNK.

<sup>2)</sup> Exception: HMV01.1R-W0120 have no integrated mains contactor and additionally require an external mains contactor.

## Control Circuits for the Mains Connection

**Mains connection without mains contactor**

You do not need to use mains contactors in the mains connection, if the following conditions **simultaneously** apply to the respective application:

- the safety-related requirements of the application allow this
- the local safety regulations at the site of installation allow this
- HCS02 and HCS03 drive controllers with **integrated 24V supply in individual supply**
- the drive controller has **no DC bus short circuit protection device** (ZKS) and has passive charging current limitation ( $R_{Softstart}$ )
- **no components with DC bus short circuit protection device** (e.g. HLB) are supplied at the DC bus of the drive controller
- the **24V supply** of other drive controllers (e.g. HMS, HMD) and additional components (e.g. HLB, HLC) operated at the DC bus **has already been applied**, before mains voltage is switched on

Before doing without mains contactors, make sure that operator protection is as good as with external mains contactors!

**Make use of the protection by mains contactors in the mains connection.**

For the data for the rating of appropriate mains contactors incl. fuses and cable cross section, see Project Planning Manual "Rexroth IndraDrive Supply Units and Power Sections" → Chapter of the respective device → "Technical Data" → "Basic Data" → table "Data for mains voltage supply".

**Using and Arranging an Additional Mains Contactor**

When the safety regulations require the circuit interruption in the mains connection to be carried out in redundant form, it is necessary to have additional mains contactors in the mains connection.

Additional mains contactors are allowed at

- HMV supply units
- HCS drive controllers



Place the additional mains contactor **electrically before**

- mains filter
- mains choke
- mains contactor (integrated or externally installed)
- mains input of supply unit or drive controller

Observe the following aspect for **PLC programming**:

The additional mains contactor must already have been connected, before the request "power ON" is applied to the supply unit or drive controller.

At installations with additional mains contactor, there are **2 mains contactors** effective:

1. the integrated or external mains contactor of the supply unit or drive controller which is controlled by the control circuit for mains connection
2. the additional mains contactor which is controlled by an independent control circuit (e.g. from a PLC)

## 9.3 Control Circuits for Mains Connection of Rexroth IndraDrive C Drive Controllers

### 9.3.1 General Information

The mains contactor connected in the incoming circuit controls the energy flow to the drive controller. This allows separation from the mains in the case of error. The Bb contact at the control section of the drive controller or the Bb contact of the mains supply decisively influences the control circuit.

#### Control Circuits HCS02

For HCS02 drive controllers, the following control circuits for the mains connection are described:

- control via external mains contactor
- control via external mains contactor for devices with integrated control voltage supply
- control via external mains contactor with DC bus resistor unit HLB01.1C

#### Control Circuits HCS03

For HCS03 drive controllers, the following control circuits for the mains connection are described:

control via external mains contactor

#### Configuration Rel 1 as Bb Contact

Power voltage is only switched to drive system, when the closing of the Bb contact signals readiness for power voltage on.

For this purpose, there is the isolated contact "Rel 1" at the control sections. The behavior of this contact can be configured via the "P-0-0860, Converter configuration" parameter:

- behaves as **converter**, if drive controller is to get supply voltage via mains connection (e.g. for type of mains connection individual supply or central supply)
- behaves as **inverter**, if drive controller is to get supply voltage via connection DC bus (L+, L-) (e.g. for type of mains connection central supply as supplied device)

Include the converter contacts in the control circuit in such a way that they make the mains contactor drop out in the case of error (when the contact opens).

You can assign other information to the "Rel 1" contacts of the drive controllers configured as inverters. Via this contact you can, for example, control a second holding brake by entering a signal from "S-0-0398, IDN list of configurable data in signal status word" in parameter "P-0-0300, Digital I/Os, assignment list".

(See also Functional Description of firmware: "Power Supply" and Parameter Description of firmware for P-0-0300 and P-0-0861)

### 9.3.2 Control via External Mains Contactor - HCS02 and HCS03

#### General Information



**CAUTION**

#### Risk of damage!

Before switching the drive controller on again, wait at least for **300 ms plus the switch-off delay of the mains contactor**.

Control Circuits for the Mains Connection

Standard Design for HCS02 and HCS03 Drive Controllers

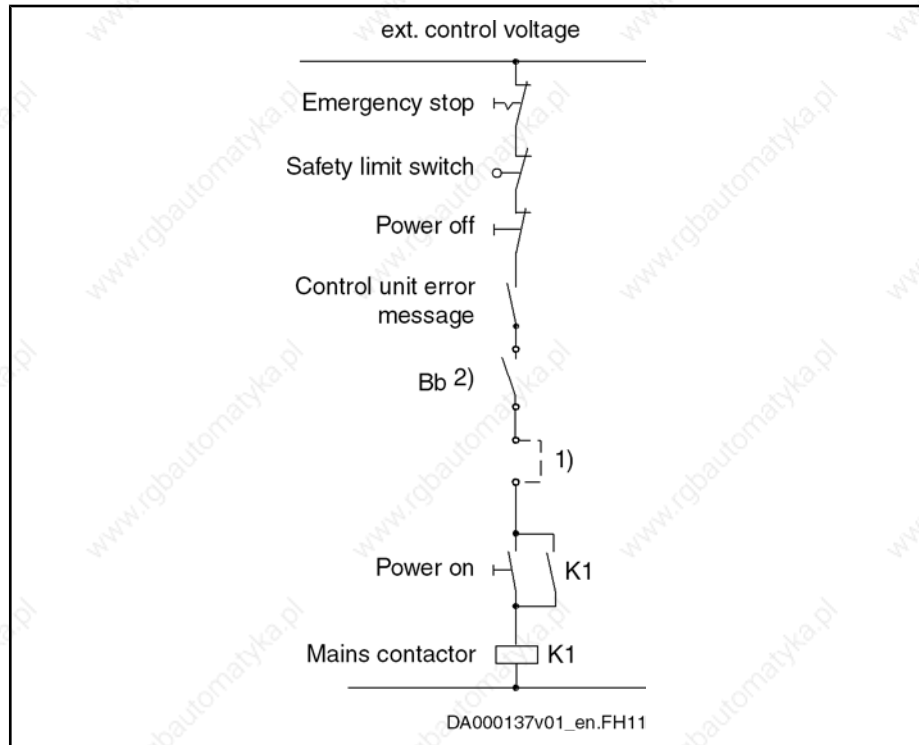

- 1) integration of the Bb contacts of other devices and configuration (see "Configuration Rel 1")
- 2) take switching capacity of Bb contact into account

Fig. 9-2: Control circuit

Design for HCS02 and HCS03 Drive Controllers with Integrated 24V Control Voltage Supply

Drive controllers with integrated 24V control voltage supply are used, for example, to maintain signal processing for controlled return motion in case the external 24V control voltage supply fails.



The integrated 24V control voltage supply cannot be used for motor brake supply.  
To supply the motor brakes, use an external 24V supply.

Design for HCS02 and HCS03 Drive Controllers with Integrated 24V Control Voltage Supply and CSB01.1N-FU Control Sections

When using the drive controllers HCS02.1E-...-NNNV and HCS03.1E-...-NNNV with CSB01.1N-FU control sections, it is possible to do without the external 24V control voltage supply.

## Control Circuits for the Mains Connection

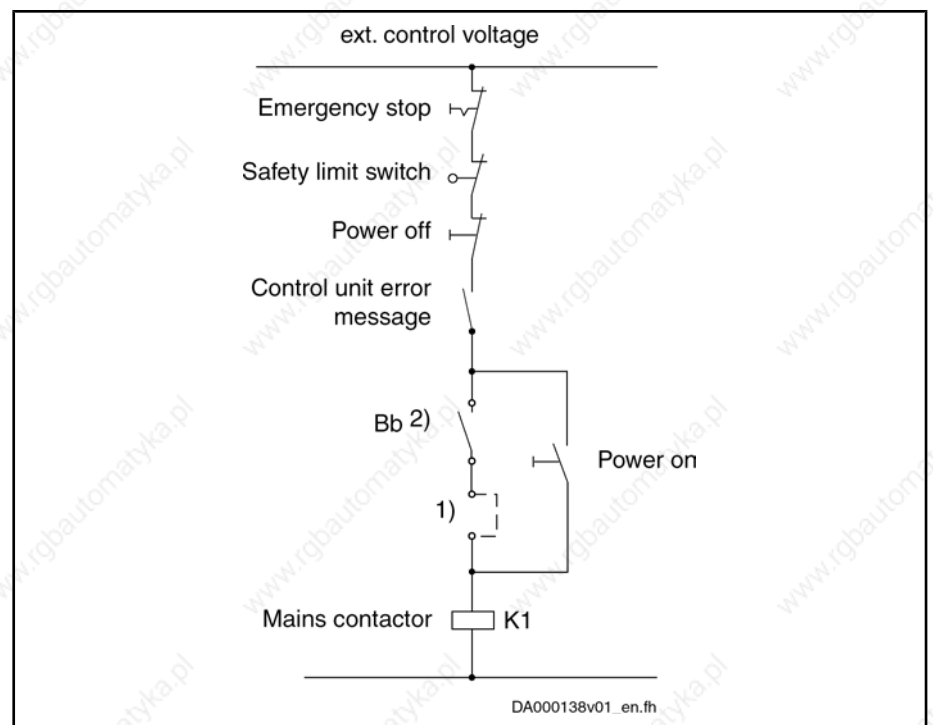

- 1) integration of the Bb contacts of other devices and configuration (see "Configuration Rel 1")
- 2) take switching capacity of Bb contact into account (see Project Planning Manual of control section), CSB01.1N-FU control sections have switch contacts with high switching capacity

Fig.9-3: Control circuit for HCS02.1E-...-NNNV drive controllers



Observe the allowed switching capacity of the Bb contact of the CSB01.1-FU control sections.

Compared to other control sections, only the CSB01.1-FU control section has a Bb contact with allowed switching voltage of AC 250 V.



Until the internal supply voltages are built up and the firmware is actively working in the drive controller, the Bb contact at the control section of the drive controller is open.

Take these times into account for the design of the mains connection.

### 9.3.3 Control Circuits HCS02 and HCS03 with DC Bus Resistor Unit HLB01.1C or HLB01.1D

**Usage** Use this variant, when

- only motors with permanent magnet excitation are connected
- motors with permanent magnet excitation and asynchronous motors (induction machines) are connected

**Features** Due to the DC bus short circuit, motors with permanent magnet excitation can be shutdown with deceleration even if the electronic system of the drive is disturbed.



Control Circuits for the Mains Connection



**Personal injury caused by uncontrolled axis motion!**

The DC bus short circuit protects machines in the case of drive errors. By itself it cannot assume the function of personal protection. In the case of errors in the drive or supply unit, uncontrolled drive motion can occur even when the DC bus short circuit has been activated.

Asynchronous machines do not brake when the DC bus has been short-circuited. Personal injury can occur according to the machine design.

Provide additional monitors and protective devices on the installation side.

**Operating Principle**

When the emergency stop pushbutton is actuated, the mains contactor drops out which activates the DC bus short circuit device in HLB.

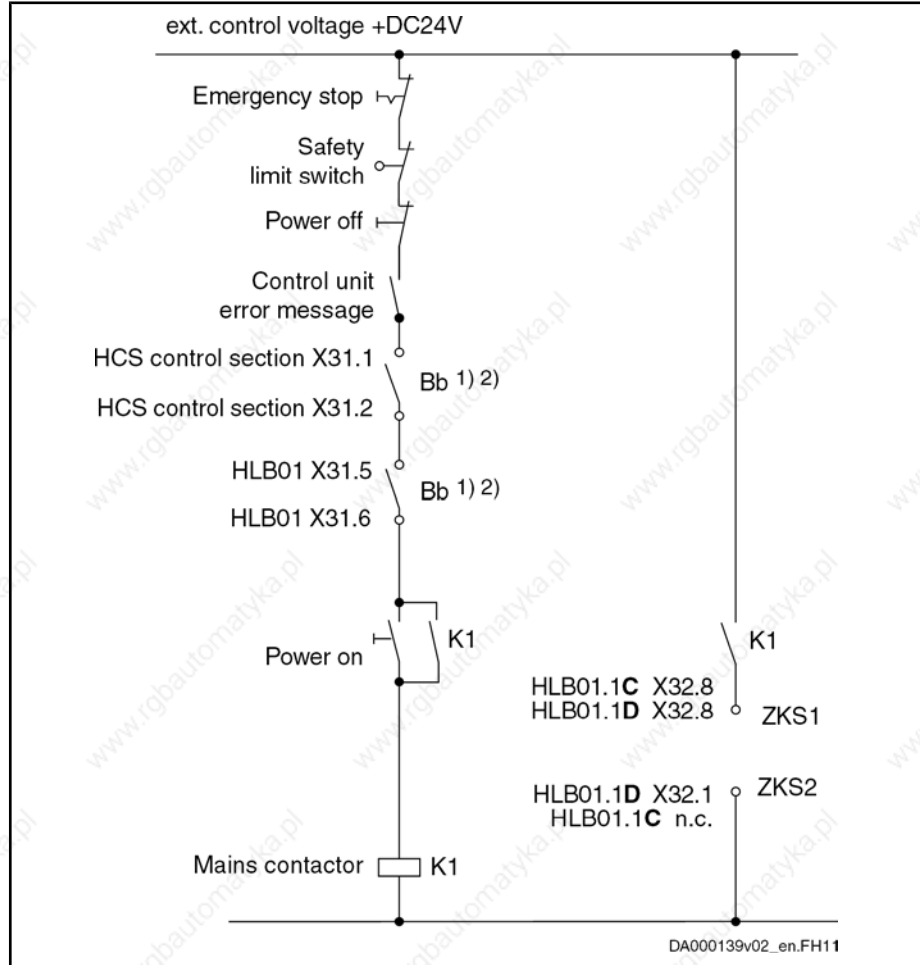

- 1) integration of the Bb contacts of other devices and configuration (see "Configuration Rel 1")
  - 2) take switching capacity of Bb contact into account (see technical data)
- K1 auxiliary contacts at mains contactor

Fig.9-4: Wiring diagram HLB01.1 and HCS



Connect the Bb contact of HLB in series with the Bb contacts of the involved IndraDrive components so that the mains contactor can be opened even if the module bus is defective.



**Avoid switching on upon short circuit in DC bus!**

Switch auxiliary contact K1 (N/O contact) before the ZKS1 input so that DC bus short circuit device is deactivated before mains contactor is switched on.

## 9.4 Control Circuits for Mains Connection of Rexroth IndraDrive M Supply Units

### 9.4.1 General Information

**Damage to the supply unit!**

At HMV01.1R supply units, there must be **at least 10 ms** between the request mains OFF (signal at X32.6 / X32.7) and the disconnection of the mains voltage, so that the energy flow has been interrupted when the disconnection process starts.

You can make sure this order is observed by appropriate switch elements (e.g. by a main switch of the control cabinet with leading auxiliary contact). For this purpose, connect the auxiliary contact in series with mains OFF.

**Do not switch on HMV supply units simultaneously!**

In the switch-on sequence of the supply unit, the supplying mains is loaded with the current  $I_{L\_trans\_max\_on}$  for the purpose of analysis.

During the unloading process, voltage overshoot can occur at the mains components connected in the incoming circuit (e.g. mains filters) due to inductances connected in the incoming circuit, e.g. the leakage inductance of the mains transformer.

**With 3 or more HMV supply units at the common supply mains:**  
Switch on supply units one after the other with a time interval of at least 0.5 seconds so that the inrush currents are not added.

**Control Circuits HMV**

For HMV01.1E, HMV01.1R and HMV02.1R supply units, the following control circuits for the mains connection are described:

- control circuit for parallel operation HMV01.1E master-slave
- deceleration in the case of disturbed electronic system of drive
- deceleration in the case of emergency stop or mains failure
- control by emergency stop relay with DC bus short circuit
- control by emergency stop relay without DC bus short circuit
- control by control unit
- combination with DC bus resistor unit HLB01.1D

### 9.4.2 Parallel Operation HMV01

For the type of mains connection "group supply with DC bus connection", use the control circuit master-slave when using HMV01.1E supply units. See the block diagram below:

Control Circuits for the Mains Connection

Control circuit for parallel operation HMV01.1E master-slave

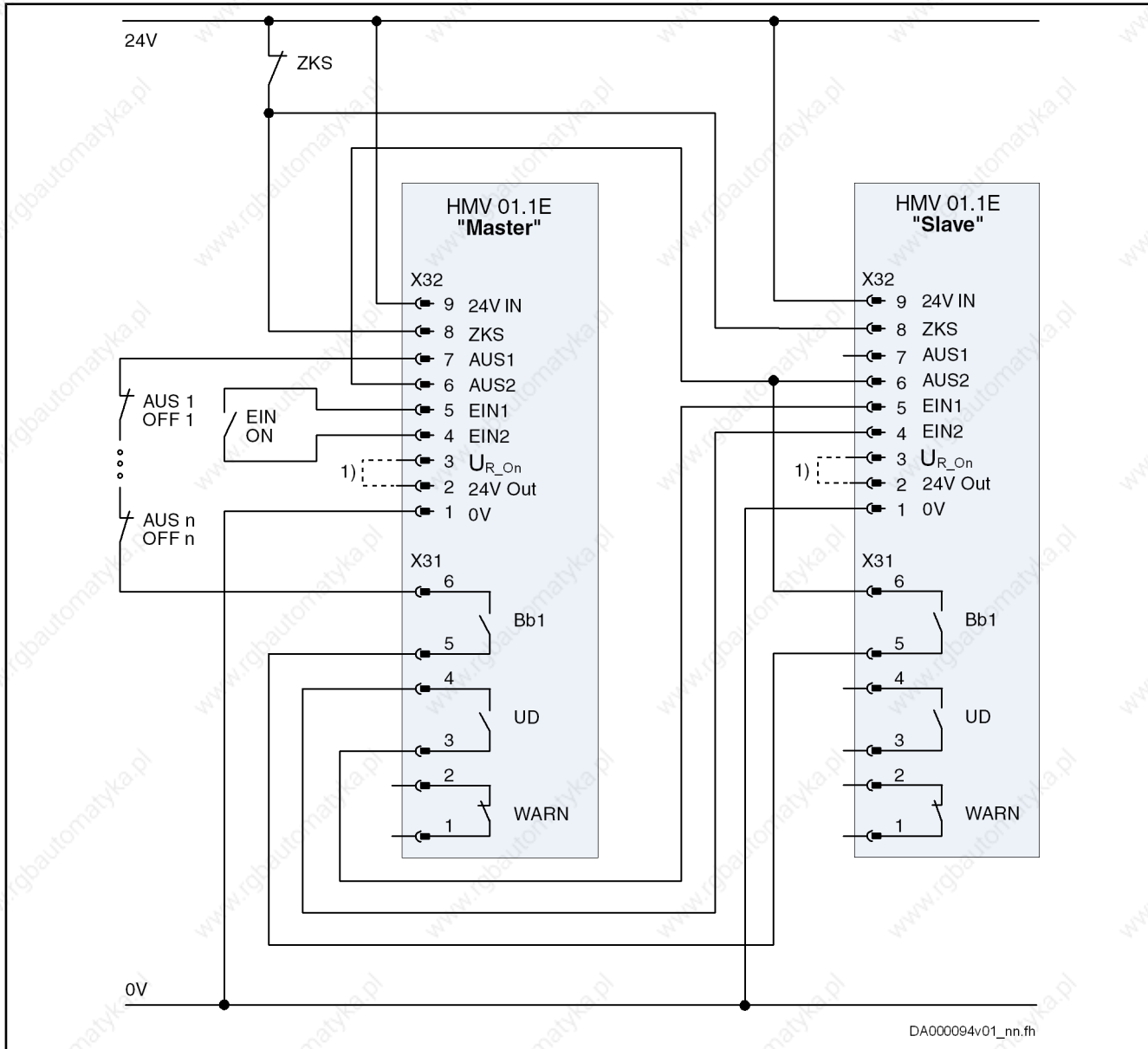

1) braking resistor switch-on threshold activated  
 Fig.9-5: Block diagram control circuit master-slave for parallel operation HMV01.1E

### 9.4.3 Deceleration in the Case of Disturbed Electronic System of Drive (DC Bus Short Circuit is Activated)

#### General Information

If the electronic system of the drive is disturbed, motors can coast in an uncontrolled way. In these cases, it is possible to short-circuit the DC bus voltage as a measure in addition to shutdown with deceleration of the drives in case the electronic system is disturbed.

In HMV supply units<sup>3)</sup> a circuit has been integrated which can discharge the DC bus as quickly as possible to low voltage. This circuit is called **DC bus short**

<sup>3)</sup> not available in HMV01.1R-W0120

## Control Circuits for the Mains Connection

**circuit (ZKS).** With active DC bus short circuit, a low-impedance resistor is connected to the DC bus between L+ and L- via a wear-free switch.

**Type of motor and DC bus short circuit**

Asynchronous drives do not decelerate when the DC bus voltage has been short-circuited!

When the DC bus has been short-circuited, motors with permanent magnet excitation generate brake torque and are decelerated.

**Control Circuits With DC Bus Short Circuit (ZKS)**

If you control the mains contactor in the supply unit by an emergency stop relay and short-circuit the DC bus, you achieve a high degree of safety with little effort. The monitoring functions of the drive system are then used in the most effective way.

**DC bus short circuit at HMV without integrated circuit for DC bus short circuit**

Use HLB01 DC bus resistor units for DC bus short circuit.

It is not recommended to short-circuit the motor connections.

**Usage**

Use this variant, when

- only motors with permanent magnet excitation are connected
- motors with permanent magnet excitation and asynchronous motors (induction machines) are connected
- the emergency stop switch has to be duplicated or a safety door monitor, for example, is required
- your drive system has an extensive emergency stop circuit

**Maximum resistance of control circuit**

The pickup current of the auxiliary relay for control of the mains contactor flows via the emergency stop circuit. In order that the mains contactor picks up reliably, the total resistance of the emergency stop circuit taking effect between connections X32/1 and X32/9 has to be less than 45 Ω!

**Features**

Due to the DC bus short circuit, motors with permanent magnet excitation can be shutdown with deceleration even if the electronic system of the drive is disturbed. In order to trigger a DC bus short circuit in such a case, the Bb contacts **of the drive controllers** have to be connected in series with the control contact and wired in the emergency stop circuit. The DC bus short circuit only takes effect in the case of drive failure. If emergency stop is actuated, asynchronous drives therefore are braking, too.

When the Bb contacts **of the supply unit** are connected in series with the control contact in the emergency stop circuit, the DC bus dynamic brake is only triggered in the case of a supply unit error.

In the case of emergency stop or when the monitors of the supply unit trigger (e.g. mains failure), the electronic system of the drives shuts them down according to the error reaction that was set.

## Control Circuits for the Mains Connection

---



### WARNING

#### Personal injury caused by uncontrolled axis motion!

The circuit for DC bus short circuit protects machines in the case of drive errors. By itself it cannot assume the function of personal protection. In the case of errors in the drive and supply unit, uncontrolled drive motion can occur even when the DC bus short circuit has been activated.

Asynchronous machines do not brake when the DC bus has been short-circuited. Personal injury can occur according to the machine design.

Use additional monitors and protective devices on the installation side.

Use Rexroth's "integrated safety technology".

---

#### Operating Principle

When the emergency stop pushbutton is actuated, the mains contactor in the supply unit opens. The emergency stop relay or an auxiliary contact of the mains contactor switches off the drive enable signals. The drives are shut down according to the error reaction set in the drive controller.

The mains contactor is switched off and the DC bus short circuit (ZKS) takes effect, when

- the supply unit (Bb1 contact) outputs a drive error message
- the control unit (CNC contact) outputs an error message
- the limit switch (S2) is passed

Control Circuits for the Mains Connection

Control circuit "DC bus short circuit (ZKS) in the case of disturbed electronic system of drive" for the mains connection of HMV01.1E supply units with integrated mains contactor (e.g. HMV01.1E-W0030, -W0070, -W0120)

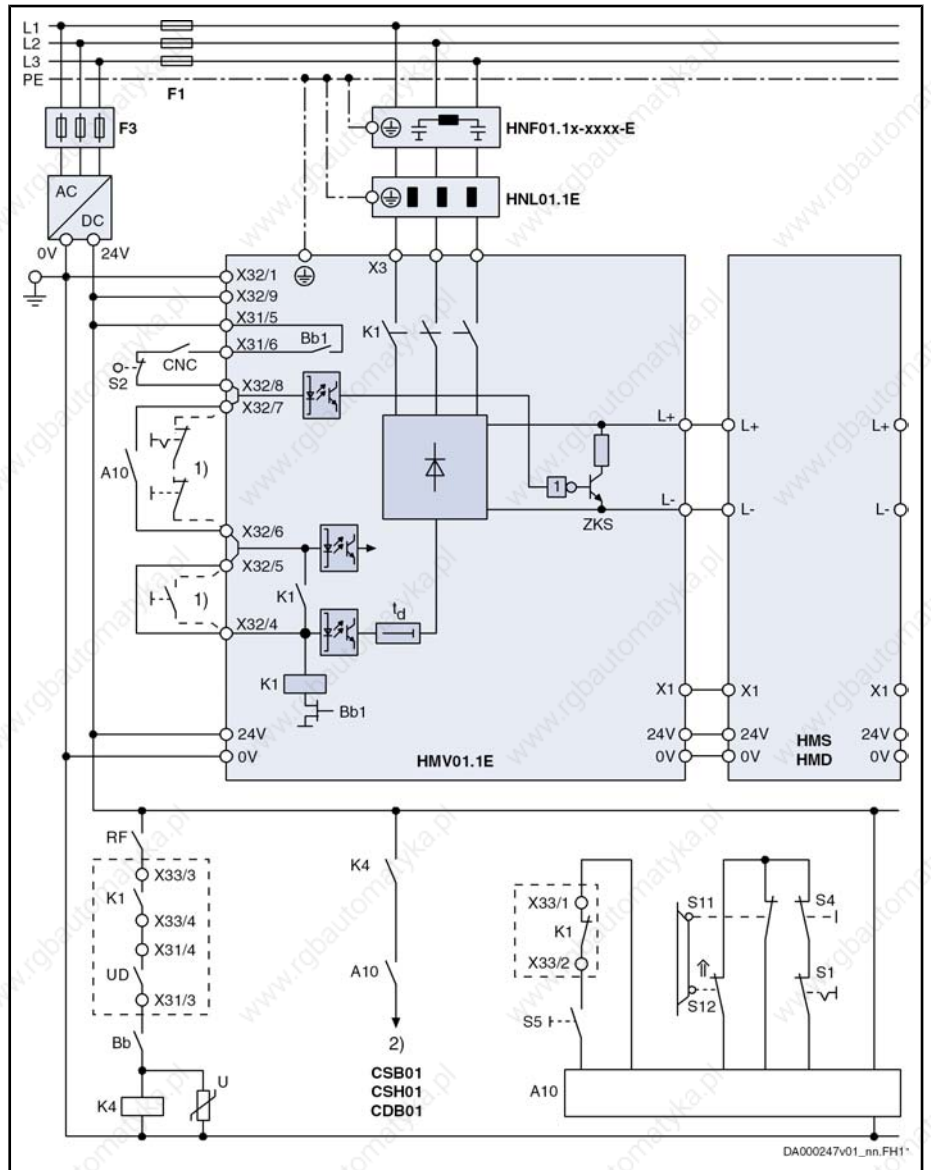

- F1 fuse of power supply
- F3 fuse of 24V power supply unit
- 1) control of K1, if A10 is not used
- 2) drive enable (via input at control section or via master communication); see also parameter "P-0-4028, Device control word"
- A10 emergency stop relay (example of circuit)
- Bb1 readiness for operation of supply unit
- Bb readiness for operation of drive controllers (see control section X31.1 and X31.2)
- CNC lag error message of control unit
- K1 integrated mains contactor
- K4 control of drive enable
- S1 emergency stop
- S2 axis end position
- S4 power Off
- S5 power On
- S11, S12 safety door monitor
- ZKS DC bus short circuit
- HNL, HNF optional, depending on the application

Fig.9-6: Control circuit DC bus short circuit (ZKS) in the case of disturbed elec-

## Control Circuits for the Mains Connection

*Electronic system of drive for HMV01.1E supply units with integrated mains  
contactor*

Control Circuits for the Mains Connection

Control circuit "DC bus short circuit (ZKS) in the case of disturbed electronic system of drive" for the mains connection of HMV01.1R supply units with integrated mains contactor (e.g. HMV01.1R-W0018, -W0045, -W0065)

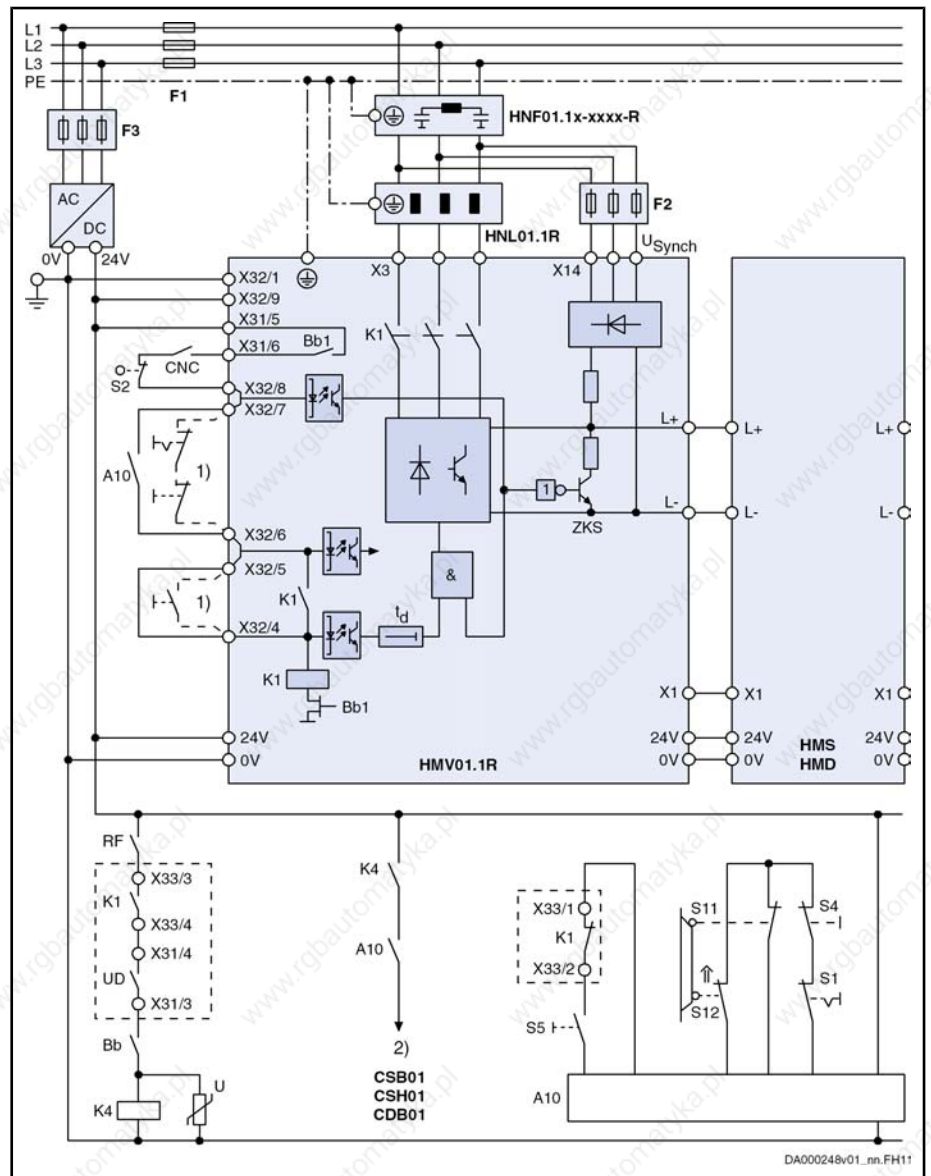

- F1 fuse of power supply
- F2 fuse of synchronization connection X14
- F3 fuse of 24V power supply unit
- 1) control of K1, if A10 is not used
- 2) drive enable (via input at control section or via master communication); see also parameter "P-0-4028, Device control word"
- A10 emergency stop relay (example of circuit)
- Bb1 readiness for operation of supply unit
- Bb readiness for operation of drive controllers (see control section X31.1 and X31.2)
- CNC lag error message of control unit
- K1 integrated mains contactor
- K4 control of drive enable
- S1 emergency stop
- S2 axis end position
- S4 power Off
- S5 power On
- S11, S12 safety door monitor
- ZKS DC bus short circuit

Fig.9-7: Control circuit DC bus short circuit (ZKS) in the case of disturbed elec-



## Control Circuits for the Mains Connection

*tronic system of drive for HMV01.1R supply units with integrated mains contactor*

### Operating Principle With HLB01.1D

When the emergency stop pushbutton is actuated, the mains contactor in the supply unit drops out. The emergency stop relay or an auxiliary contact of the mains contactor switches off the drive enable signals. The drives are shut down according to the error reaction set in the drive controller.

The mains contactor is switched off and the DC bus short circuit (ZKS) takes effect in HMV and HLB, when

- the supply unit (Bb1 contact) outputs a drive error message
- the control unit (CNC contact) outputs an error message
- the limit switch (S2) is passed



**CAUTION**

### Risk of damage to the device!

Establish connection from **HMV\_X32/8** to **HLB\_X32/7**.

This avoids energy from the mains connection being supplied and the DC bus short circuit protection device of the DC bus resistor unit HLB being simultaneously active.

---

Control circuit "DC bus short circuit (ZKS) at HMV and HLB in the case of disturbed electronic system of drive" for the mains connection of HMV01.1R supply

Control Circuits for the Mains Connection

units with integrated mains contactor (e.g. HMV01.1R-W0018, -W0045, -W0065) and DC bus resistor unit HLB01.1D

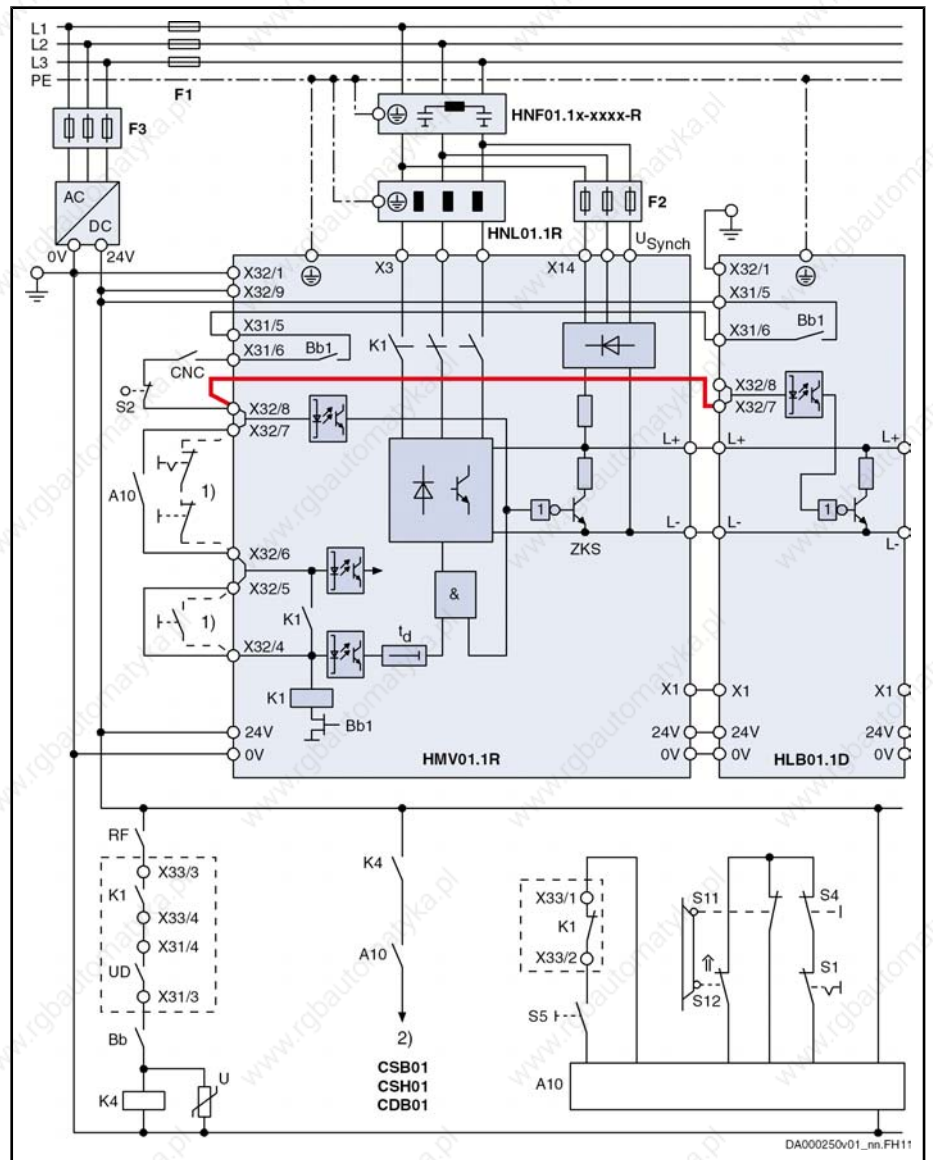

- F1 fuse of power supply
- F2 fuse of synchronization connection X14
- F3 fuse of 24V power supply unit
- 1) control of K1, if A10 is not used
- 2) drive enable (via input at control section or via master communication); see also parameter "P-0-4028, Device control word"
- A10 emergency stop relay (example of circuit)
- Bb1 readiness for operation of supply unit
- Bb readiness for operation of drive controllers (see control section X31.1 and X31.2)
- CNC lag error message of control unit
- K1 integrated mains contactor
- K4 control of drive enable
- S1 emergency stop
- S2 axis end position
- S4 power Off
- S5 power On
- S11, S12 safety door monitor
- ZKS DC bus short circuit

Fig.9-8: Control circuit DC bus short circuit (ZKS) at HMV and HLB in the case

Control Circuits for the Mains Connection

*of disturbed electronic system of drive for HMV01.1R supply units with integrated mains contactor and HLB01.1D*

## 9.4.4 Deceleration in the Case of Emergency Stop or Mains Failure

### General Information

In the case of emergency stop or mains failures, the drives normally are shut-down by drive control.

In the case of emergency stop or when the drive-internal monitors trigger, the drive control inputs the command value "zero". The drives are thereby decelerating in a controlled way with maximum torque.

In some applications (e.g. electronically coupled gear cutting machines) it is required that the drive shutdown is controlled by the control unit in the case of emergency stop or mains failures. In the case of emergency stop or when the drive-internal monitors trigger, the control unit decelerates the drives in a position-controlled way. In such applications, the **DC bus short circuit must not be activated**.

For further details, see the Functional Description of the firmware under the index entry "Best possible deceleration".

### Control Circuit "Position-Controlled Shutdown by the Control Unit" Without DC Bus Short Circuit (ZKS)

If the mains contactor is controlled by the control unit, the drive, in the case of emergency stop or when the drive-internal monitor triggers, can be shut down in a position-controlled way by a control unit.

**Usage** This kind of mains contactor control is mainly used for electronically coupled drives that are shut down synchronously even in the case of mains failure.

**Features** The DC bus voltage is not short-circuited so that there is energy available for position-controlled shutdown of the drives.



The energy stored in the DC bus or the regenerated energy has to be greater than the energy required for excitation of asynchronous machines or for return motions.

The parameter "Activation of NC reaction on error" has to be set accordingly in the drive controller (P-0-0117, bit 0 = 1).

In the case of emergency stop or when the monitors of the supply unit trigger (e.g. mains failure), the drives are shut down in a position-controlled way by the positioning control.

**Operating Principle** When the emergency stop circuit opens or the monitors of the supply unit trigger (e.g. mains failure), the mains contactor in the supply unit drops out.

For drives with SERCOS interface, the error is signaled to the control unit and the drives can be shut down in a position-controlled way.

For drives without SERCOS interface, the control unit has to evaluate the UD contact. When the UD contact triggers, the control unit has to shut down the drives.



**CAUTION**

**Damage to machines caused by unbraked coasting to stop of the drives in case DC bus voltage is too low!**

The control unit should evaluate the UD contact and shut the drives down when the contact triggers.

Control Circuits for the Mains Connection

Control circuit "position-controlled shutdown by the control unit" for the mains connection of HMV01.1R supply units with integrated mains contactor (e.g. HMV01.1R-W0018, -W0045, -W0065)

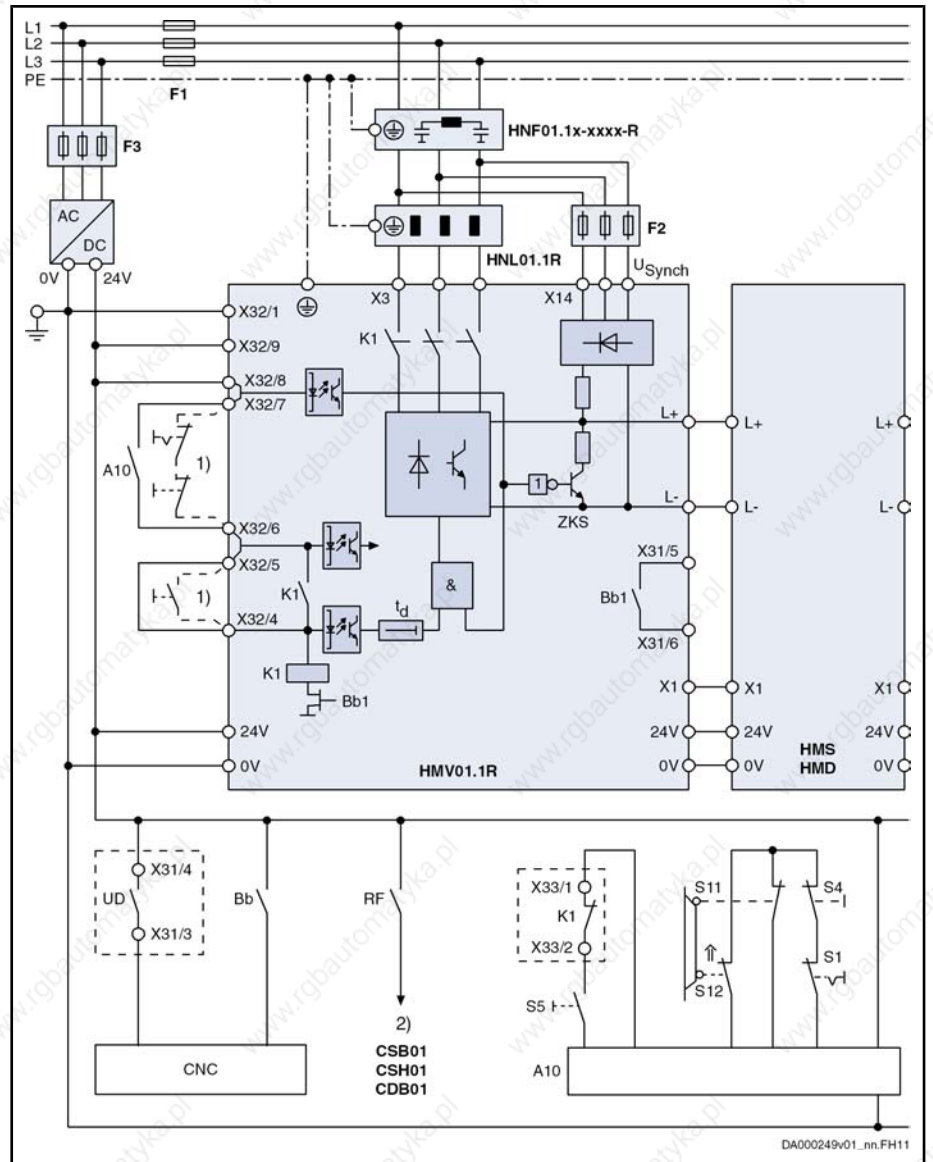

- F1 fuse of power supply
  - F2 fuse of synchronization connection X14
  - F3 fuse of 24V power supply unit
  - 1) control of K1, if A10 is not used
  - 2) drive enable (via input at control section or via master communication); see also parameter "P-0-4028, Device control word"
  - A10 emergency stop relay (example of circuit)
  - Bb1 readiness for operation of supply unit
  - Bb readiness for operation of drive controllers (see control section X31.1 and X31.2)
  - CNC control unit of installation
  - K1 integrated mains contactor
  - K4 control of drive enable
  - S1 emergency stop
  - S2 axis end position
  - S4 power Off
  - S5 power On
  - S11, S12 safety door monitor
  - ZKS DC bus short circuit
- Fig.9-9: Control circuit without DC bus short circuit (ZKS), position-controlled

## Control Circuits for the Mains Connection

*shutdown by the control unit for HMV01.1R supply units with integrated  
mains contactor*

### Control Circuit Emergency Stop Relay Without DC Bus Short Circuit (ZKS)

- Usage**
- If unbraked coasting to stop of the drives does not damage the installation.
  - If only asynchronous motors are connected to the supply unit.
  - If the end positions of the feed axes have been sufficiently cushioned.
  - If external braking devices are used.

**Features** The DC bus voltage is not short-circuited.

In the case of emergency stop or when the monitors of the supply unit trigger (e.g. mains failure), the drives are shut down according to the error reaction set in the drive controller.

**Operating Principle** When the emergency stop circuit opens, the mains contactor in the supply unit drops out immediately. The emergency stop relay or an auxiliary contact of the mains contactor switches off the drive enable signals. The drives are shut down according to the error reaction set in the drive controller.



**Damage to machines caused by unbraked coasting to stop of the drives  
in case their electronic system is disturbed!**

Use motors with mechanical brake (a holding brake mustn't be used as service brake).

Sufficiently cushion end positions of feed axes.

---



Control Circuits for the Mains Connection

Example Control circuit "without DC bus short circuit (ZKS)" for the mains connection of HMV01.1E supply units with integrated mains contactor (e.g. HMV01.1E-W0030, -W0070, -W0120)

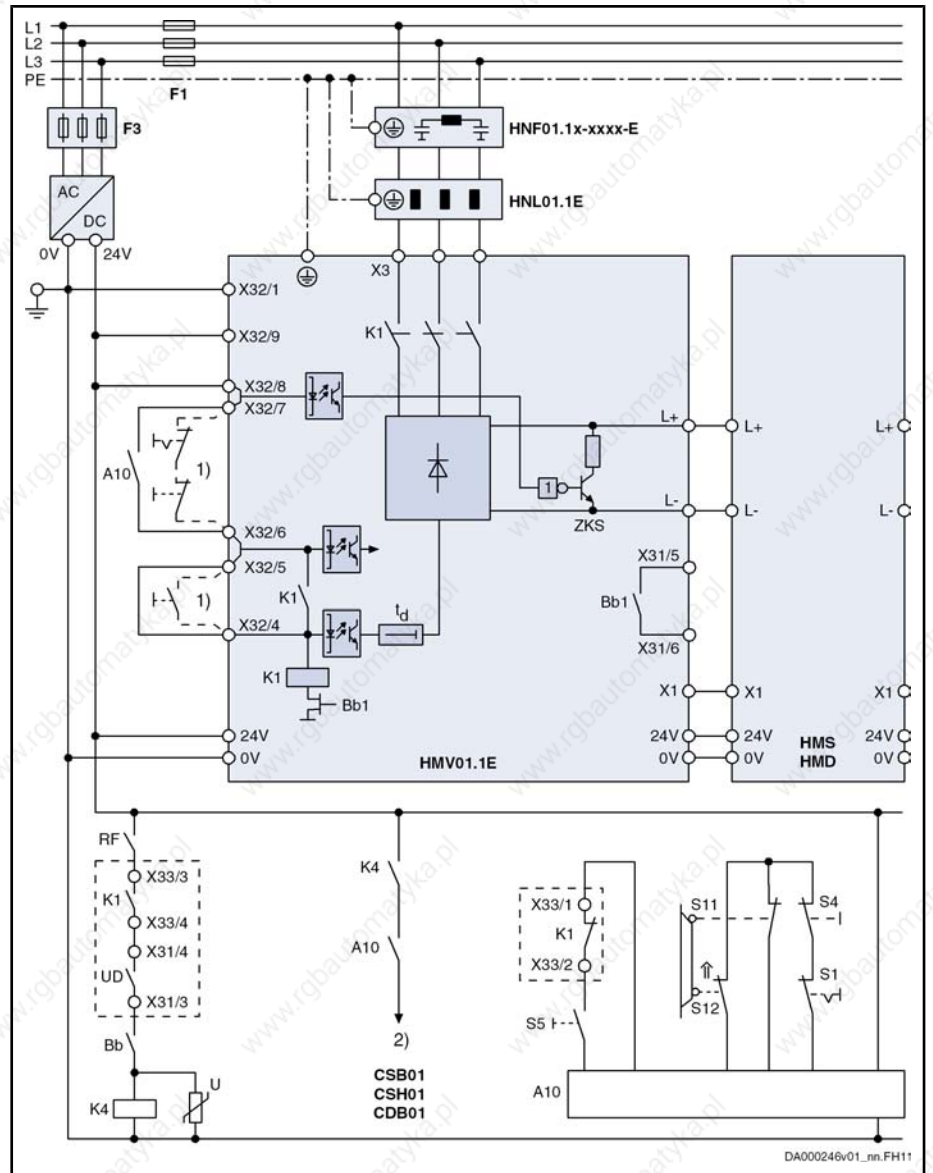

- F1 fuse of power supply
  - F3 fuse of 24V power supply unit
  - 1) control of K1, if A10 is not used
  - 2) drive enable (via input at control section or via master communication); see also parameter "P-0-4028, Device control word"
  - A10 emergency stop relay (example of circuit)
  - Bb1 readiness for operation of supply unit
  - Bb readiness for operation of drive controllers (see control section X31.1 and X31.2)
  - K1 integrated mains contactor
  - K4 control of drive enable
  - S1 emergency stop
  - S4 power Off
  - S5 power On
  - S11, S12 safety door monitor
  - ZKS DC bus short circuit
  - HNL, HNF optional, depending on the application
- Fig.9-10: Control circuit without DC bus short circuit (ZKS) for HMV01.1E supply units with integrated mains contactor

Control Circuits for the Mains Connection

Example Control circuit "without DC bus short circuit (ZKS)" for the mains connection of HMV01.1R supply units with integrated mains contactor (e.g. HMV01.1R-W0018, -W0045, -W0065)

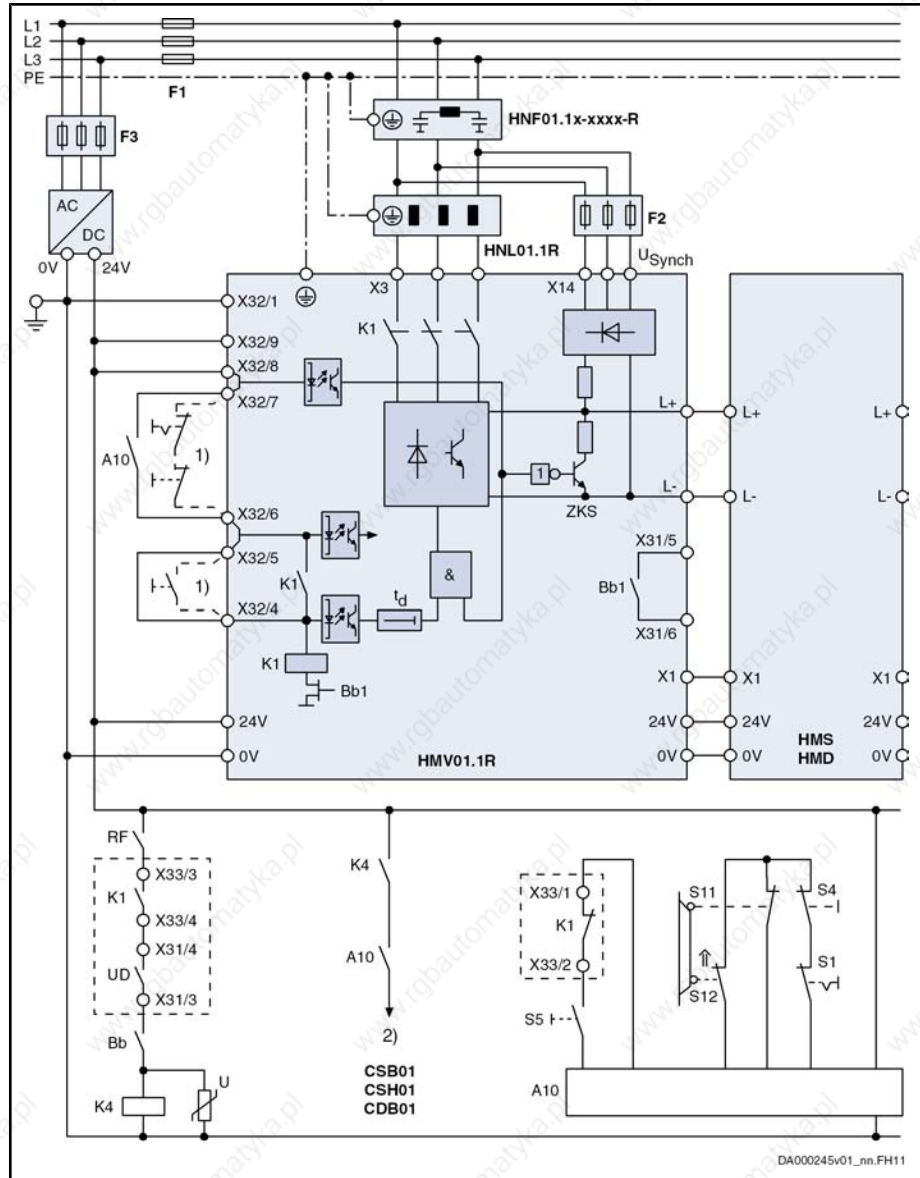

- F1 fuse of power supply
  - F2 fuse of synchronization connection X14
  - F3 fuse of 24V power supply unit
  - 1) control of K1, if A10 is not used
  - 2) drive enable (via input at control section or via master communication); see also parameter "P-0-4028, Device control word"
  - A10 emergency stop relay (example of circuit)
  - Bb1 readiness for operation of supply unit
  - Bb readiness for operation of drive controllers (see control section X31.1 and X31.2)
  - K1 integrated mains contactor
  - K4 control of drive enable
  - S1 emergency stop
  - S4 power Off
  - S5 power On
  - S11, S12 safety door monitor
  - ZKS DC bus short circuit
- Fig.9-11: Control circuit without DC bus short circuit (ZKS) for HMV01.1R supply units with integrated mains contactor



Control Circuits for the Mains Connection

Example Control circuit "without DC bus short circuit (ZKS)" for the mains connection of HMV01.1R supply units without integrated mains contactor (e.g. HMV01.1R-W0120)

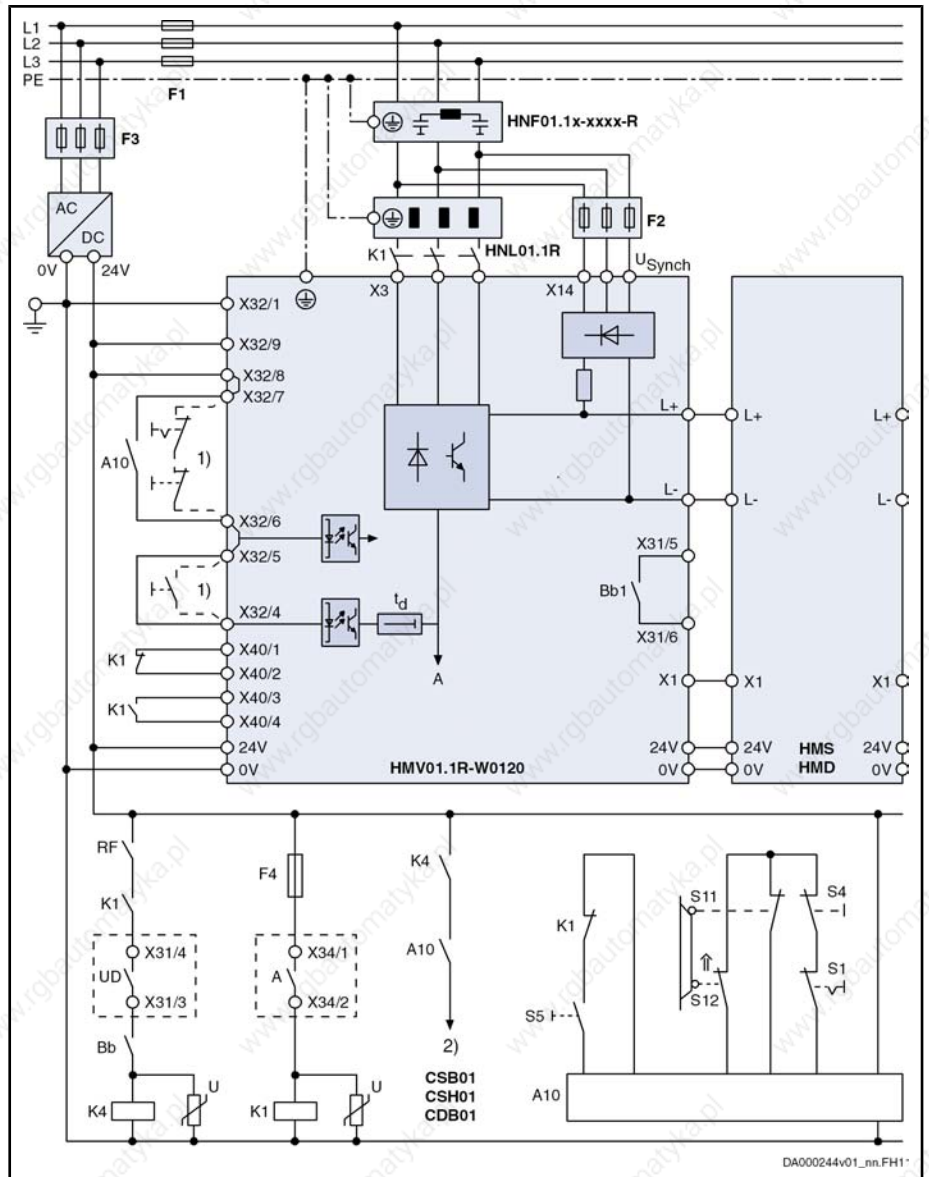

- F1 fuse of power supply
  - F2 fuse of synchronization connection X14
  - F3 fuse of 24V power supply unit
  - F4 fuse of contactor control X34
  - 1) control of K1, if A10 is not used
  - 2) drive enable (via input at control section or via master communication); see also parameter "P-0-4028, Device control word"
  - A10 emergency stop relay (example of circuit)
  - Bb1 readiness for operation of supply unit
  - Bb readiness for operation of drive controllers (see control section X31.1 and X31.2)
  - K1 mains contactor
  - K4 control of drive enable
  - S1 emergency stop
  - S4 power Off
  - S5 power On
  - S11, S12 safety door monitor
- Fig.9-12: Control circuit without DC bus short circuit (ZKS) for HMV01.1R supply units without integrated mains contactor

Control Circuits for the Mains Connection

### 9.4.5 Time Behaviors When Switching HMV Supply Units ON and OFF

#### Switching On



**Do not switch on HMV supply units simultaneously!**

In the switch-on sequence of the supply unit, the supplying mains is loaded with the current  $I_{L\_trans\_max\_on}$  for the purpose of analysis.

During the unloading process, voltage overshoot can occur at the mains components connected in the incoming circuit (e.g. mains filters) due to inductances connected in the incoming circuit, e.g. the leakage inductance of the mains transformer.

**With 3 or more HMV supply units at the common supply mains:**  
Switch on supply units one after the other with a time interval of at least 0.5 seconds so that the inrush currents are not added.

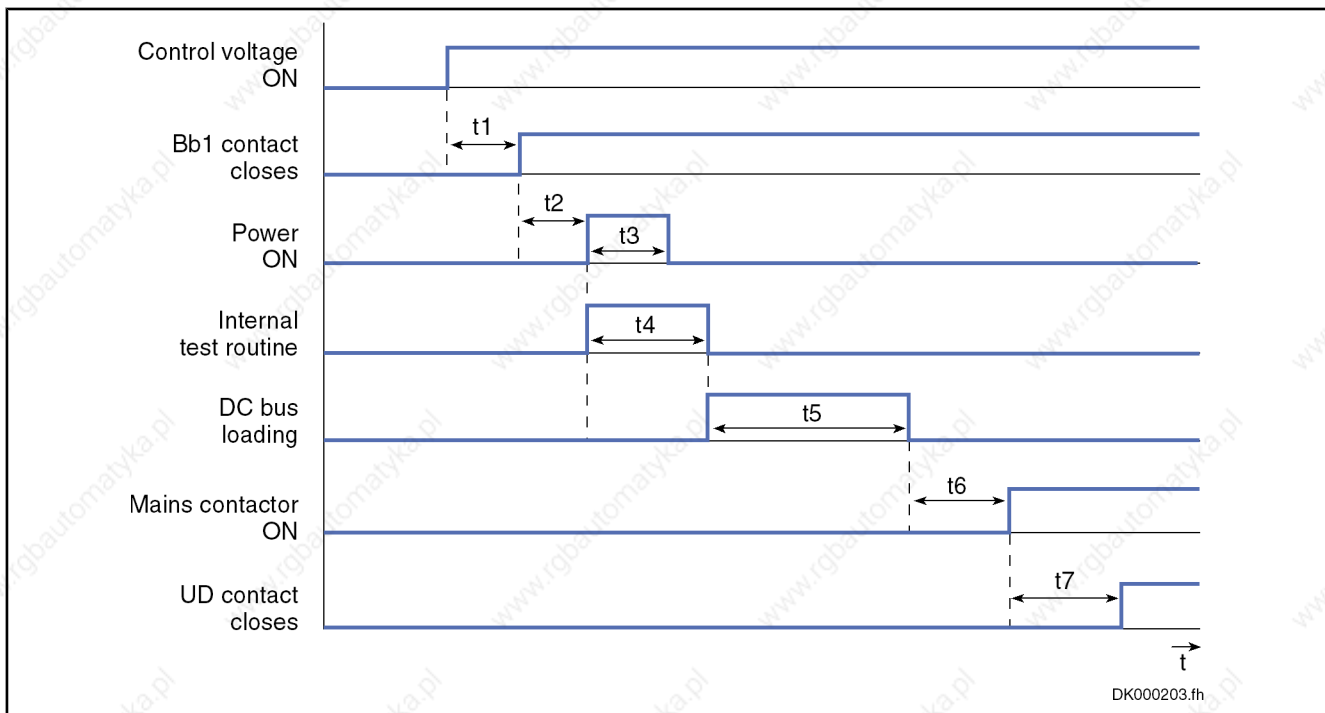

- t1 5.2 s; time for internal booting until Bb1 contact closes
- t2 Time can be set by the user. Take the time into account which is required for run-up of all devices connected to the module bus. This time depends on the control unit or the machine.
- t3 at least 250 ms; switch-on pulse
- t4 500 ms; time for internal test routines before the DC bus is loaded
- t5 time depends on DC bus capacitance (internal, external) and mains voltage
- t6 500 ms; delay time until mains contactor closes
- t7 maximum 200 ms; depends on device (ON delay of mains contactor)

Fig. 9-13: Time behavior when switching on

**Involved Connection Points**



See "Rexroth IndraDrive Supply Units and Power Sections" → chapter "Functions and Electrical Connection Points"

## Switching Off

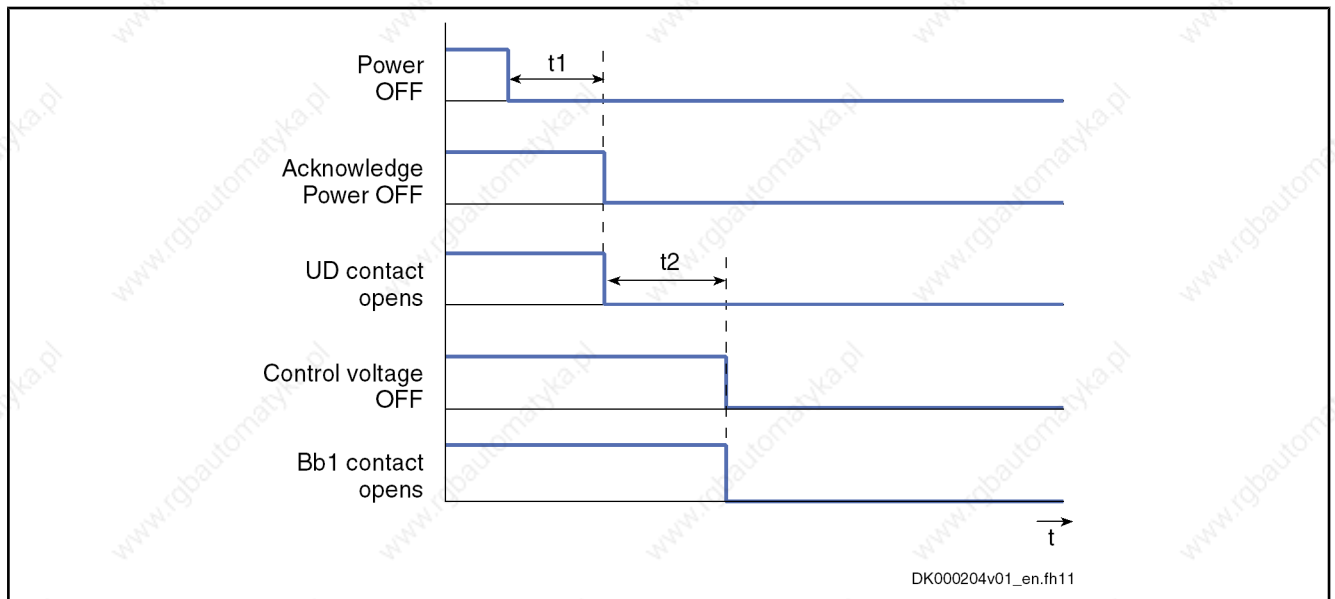

t1 maximum 200 ms; depends on device (OFF delay of mains contactor)

t2 time can be set by the user

Fig.9-14: Time behavior when switching off

**Damage to the supply unit!**

At HMV01.1R supply units, there must be **at least 10 ms** between the request mains OFF (signal at X32.6 / X32.7) and the disconnection of the mains voltage, so that the energy flow has been interrupted when the disconnection process starts.

You can make sure this order is observed by appropriate switch elements (e.g. by a main switch of the control cabinet with leading auxiliary contact). For this purpose, connect the auxiliary contact in series with mains OFF.

## Involved Connection Points



See "Rexroth IndraDrive Supply Units and Power Sections" → chapter "Functions and Electrical Connection Points"



## 10 Electromagnetic Compatibility (EMC)

### 10.1 EMC Requirements

#### 10.1.1 General Information

The electromagnetic compatibility (EMC) or electromagnetic interference (EMI) includes the following requirements:

- sufficient **noise immunity** of an electric installation or an electric device against external electric, magnetic or electromagnetic interference via lines or through air
- sufficiently low **noise emission** of electric, magnetic or electromagnetic noise of an electric installation or an electric device to other surrounding devices via lines or through air

#### 10.1.2 Noise Immunity in the Drive System

##### Basic Structure for Noise Immunity

The figure below illustrates the interfaces for definition of noise immunity requirements in the drive system.

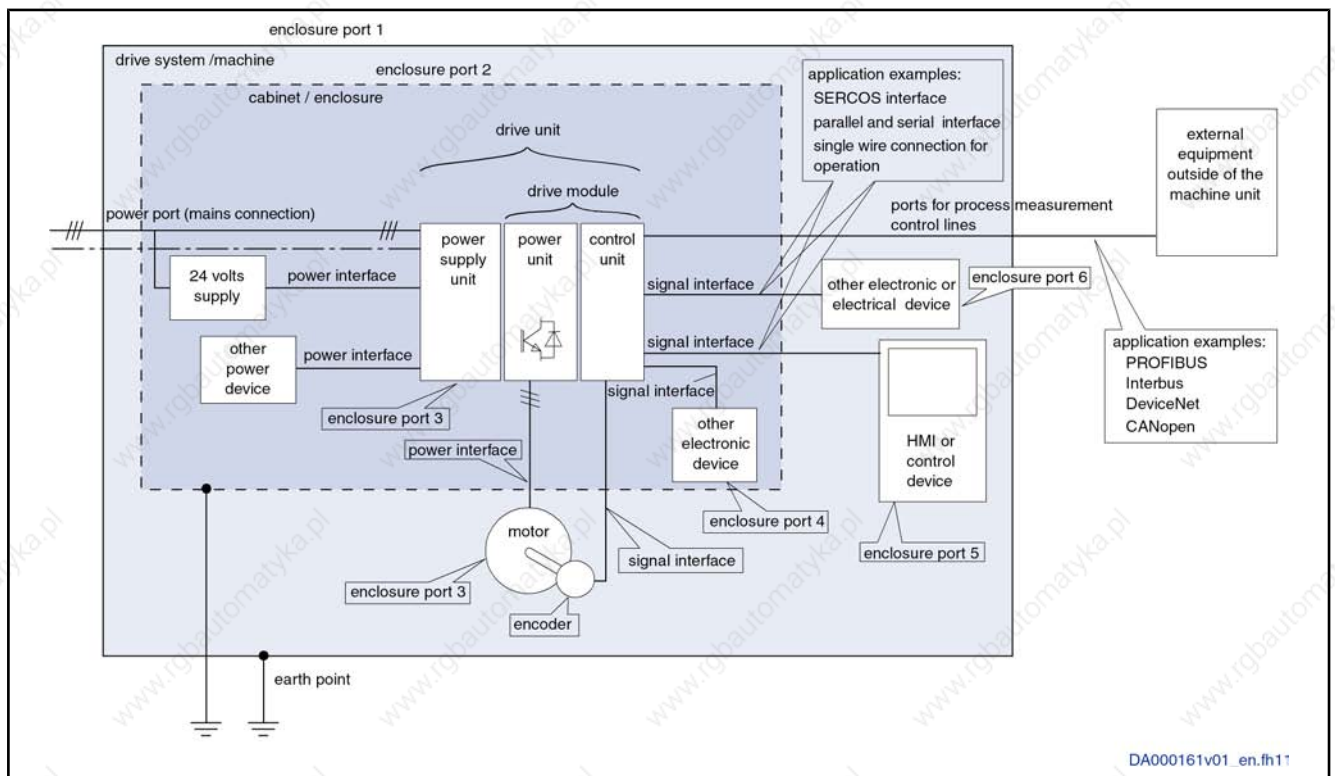

Fig. 10-1: Basic structure and noise immunity

Electromagnetic Compatibility (EMC)

Noise Immunity Limit Values

No	Place of effect	Phenomenon	Standard	Conditions	Coupling	Test values according standard EN 61800-3	Performance level
	Enclosure port		IEC 61000-4-2		CD, AD	6 kV CD, 8 kV AD, if CD not possible	B
		RF Field	IEC 61000-4-3		Via antenna on EUT	10 V / m	A
	Power port	Burst	IEC 61000-4-4	length > 3 m	mains connection I < 100 A: decoupling network I > 100 A: clamp	4 kV / 2,5 kHz (clamp)	B
		Surge	IEC 61000-4-5	Only mains connection; I < 63 A, light load test		Line – line 1 kV (2 ohm) Line – earth 2 kV (12 ohm)	B
			IEC 61000-4-6	length > 3 m	clamp	10 V, 0,15–80 MHz	A
	Power Interface	Burst	IEC 61000-4-4	length > 3 m	clamp		B
	Signal Interface	Burst	IEC 61000-4-4	length > 3 m	clamp		B
			IEC 61000-4-6	length > 3 m	Clamp or CDN	10 V, 0,15–80 MHz	B
	Ports of process; measurement control lines	Burst	IEC 61000-4-4	length > 3 m	clamp		B
			IEC 61000-4-6	length > 3 m	Clamp or CDN	10 V, 0,15–80 MHz	A

Fig.10-2: Noise immunity limit values

Evaluation criterion	Explanation (abbreviated form from EN 1800-3)
A	deviations within allowed range
B	automatic recovery after interference
C	Switched off without automatic recovery. Device remains undamaged.

Fig.10-3: Evaluation criterion

### 10.1.3 Noise Emission of the Drive System

#### Causes of Noise Emission

Controlled variable-speed drives contain converters containing snappy semi-conductors. The advantage of modifying the speed with high precision is achieved by means of pulse width modulation of the converter voltage. This can generate sinusoidal currents with variable amplitude and frequency in the motor.

The steep voltage rise, the high clock rate and the resulting harmonics cause unwanted but physically unavoidable emission of interference voltage and interference fields (wide band interference). The interference mainly is asymmetric interference against ground.

The propagation of this interference strongly depends on:

## Electromagnetic Compatibility (EMC)

- configuration of the connected drives
- number of the connected drives
- conditions of mounting
- site of installation
- radiation conditions
- wiring and installation

If the interference gets from the device to the connected lines in unfiltered form, these lines can radiate the interference into the air (antenna effect). This applies to power lines, too.

**Limit Values for Line-Based Disturbances**

According to IEC EN 61800-3 or CISPR 11 (corresponds to EN55011), the limit values in the table below are distinguished. For this documentation both standards are combined in the limit value classes A2.1 to B1.

IEC / EN 61800-3	CISPR 11 (EN55011)	Explanation	In this documentation	Curves of limit value characteristic
Category C4 2nd environment	none	One of the following 3 requirements must have been fulfilled: Mains connection current >400 A, IT mains or required dynamic drive behavior not reached by means of EMC filter. Adjust limit values to use and operation on site. User has to carry out and provide evidence of EMC planning.	none	-
Category C3 2nd environment	Class A; Group 2 I > 100 A	limit value in industrial areas to be complied with for applications operated at supply mains with nominal currents > 100 A	A2.1	1.1 1.2
Category C3 2nd environment	Class A; Group 2 I < 100 A	limit value in industrial areas to be complied with for applications operated at supply mains with nominal currents < 100 A	A2.2	2.1 2.2
Category C2 1st environment; restricted distribution	Class A; Group 1	Limit value in residential area or at facilities at low-voltage mains supplying buildings in residential areas. To be complied with for applications with restricted distribution.	A1	3.1 3.2
Category C1 1st environment; unrestricted distribution	Class B; Group 1	limit value in residential areas to be complied with for applications with unrestricted distribution	B1	4.1 4.2

Fig. 10-4: Limit value classes



Electromagnetic Compatibility (EMC)

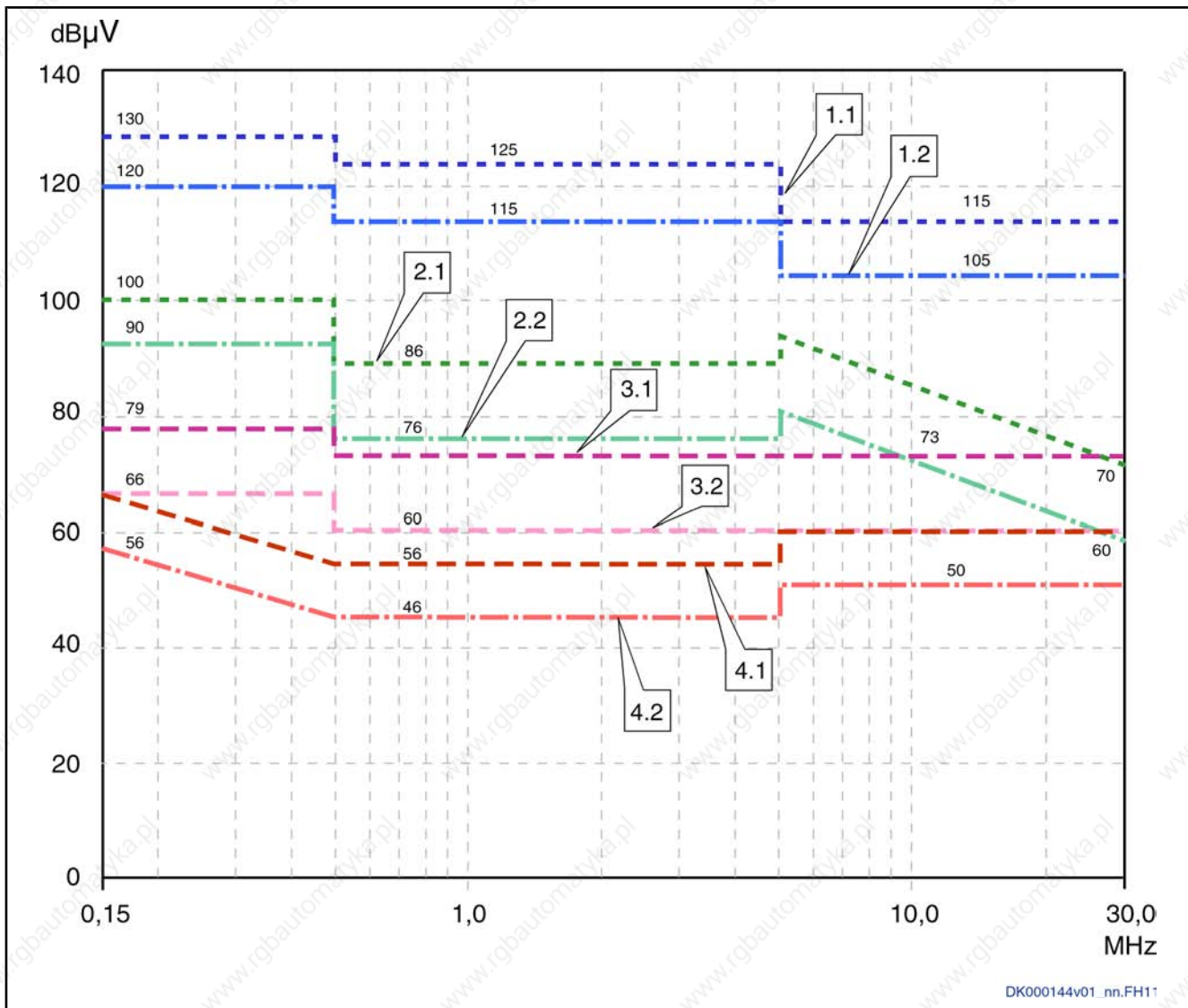

- 1.1 Category C3: second environment, QSP, I > 100 A (class A, group 2, I > 100 A)
  - 1.2 Category C3: second environment, AV, I > 100 A (class A, group 2, I > 100 A)
  - 2.1 Category C3: second environment, QSP, I < 100 A (class A, group 2, I < 100 A)
  - 2.2 Category C3: second environment, AV, I < 100 A (class A, group 2, I < 100 A)
  - 3.1 Category C2: first environment, restricted distribution, QSP (first environment, even if source of interference in second environment) (class A, group 1)
  - 3.2 Category C2: first environment, restricted distribution, AV (first environment, even if source of interference in second environment) (class A, group 1)
  - 4.1 Category C1: first environment, unrestricted distribution, QSP (first environment, even if source of interference in second environment) (class B, group 1)
  - 4.2 Category C1: first environment, unrestricted distribution, AV (first environment, even if source of interference in second environment) (class B, group 1)
- Notes
- (1) Limit value for first environment is also relevant, if source of interference of second environment affects first environment.
  - (2) Designations "class" and "group" according to IEC CISPR 11.
- QSP: measuring method quasi peak measurement; AV: measuring method arithmetic averaging

Fig. 10-5: Limit values for line-based disturbances (IEC 61800-3); limit value char-

## Electromagnetic Compatibility (EMC)

*Characteristic through frequency range***Second Environment, Industrial Area**

Facilities not directly connected to a low-voltage mains to supply buildings in residential areas.

If the limit values in an industrial area separated from public supply by a transformer station only have to be complied with at the property boundary or in the neighboring low-voltage mains, the filter might not be necessary. In the vicinity of broadcast receivers or other sensitive devices as regards high-frequency, such as measuring sensors, measuring lines or measuring devices, it is normally required to use the interference suppression filter.

Increasing the noise immunity of a sensitive device can often be the economically better solution compared to measures of interference suppression at the drive system of the installation.

**First Environment**

Environment containing residential areas and facilities directly connected, without interstage transformer, to a low-voltage mains supplying buildings in residential areas.

Medium-sized manufacturing plants and industrial establishments can be connected to the public low-voltage mains together with residential buildings. In this case there is a high risk for radio and television reception if there aren't any measures for radio interference suppression taken. Therefore, the indicated measures are generally recommended.

**Nominal Current of Supply Mains**

The nominal current of the supply mains ( $> 100 \text{ A}$  or  $< 100 \text{ A}$ ) is specified by the local power supply company at the connection point of the mains. For industrial companies, for example, such connection points are the interconnecting stations from the power supply system.

**Unrestricted Distribution**

Channel of distribution for which placing on the market is independent of the EMC expert knowledge of the customer or user of electric drives.

**Restricted Distribution**

Channel of distribution for which the placing on the market is restricted to traders, customers or users who individually or together have technical expert knowledge of EMC for the use of electric drives.

Since it is impossible to obtain the lower limit values for residential areas with all applications by means of the usual measures (like for example in the case of large and electrically not closed installations, longer motor cables or a large number of drives), the following note included in EN 61800-3 has to be observed.



Components of the drive system Rexroth IndraDrive are **products of category C3** (with restricted distribution) according to IEC 61800-3. They are not provided for use in a public low-voltage mains supplying residential areas. If they are used in such a mains, high-frequency interference is to be expected. This can require additional measures of radio interference suppression.

See the following chapters for the limit value classes (as per categories C1, C2, C3, C4 according to EN 61800-3) which can be reached for the individual drive systems and devices:

- Mains Connection of HMV01.1E Supply Units
- Mains Connection of HMV01.1R Supply Units
- Mains Connection for HCS02 Converters

## 10.2 Ensuring the EMC Requirements

**Standards and Laws**

On the European level there are the EU Directives. In the EU states these Directives are transformed into laws valid on a national level. The relevant

## Electromagnetic Compatibility (EMC)

**EMC Properties of Components**

directive for EMC is EU Directive 89/336/EEG which was transformed on the national level in Germany into the law EMVG ("Law concerning electromagnetic compatibility of devices") of 1992-11-09.

Drive and control components by Rexroth are designed and built, in accordance with the present state-of-the-art of standardization, according to legal regulations of the EU Directive EMC 89/336/EEC and the German EMC law.

The compliance with EMC standards was tested by means of a typical arrangement with a test setup conforming to standard with the indicated mains filters. The limit values according to product standard EN 61800-3 have been complied with.

Apart from the internal test at the factory, a conformity test was carried out for individual drive systems in an accredited laboratory of a CE-responsible authority.

**Applicability for End Product**

Measurements of the drive system with an arrangement typical for the system are not in all cases applicable to the status as installed in a machine or installation. Noise immunity and noise emission strongly depend on:

- configuration of the connected drives
- number of the connected drives
- conditions of mounting
- site of installation
- radiation conditions
- wiring and installation

In addition, the required measures depend on the requirements of electric safety technology and economic efficiency in the application.

In order to prevent interference as far as possible, notes on mounting and installation are contained in the application manuals of the components and in this documentation.



Observe the descriptions and notes in chapter [11 Arranging the Components in the Control Cabinet](#), page 145.

**Cases to Distinguish for Declaration of EMC Conformity**

For validity of the harmonized standards, we distinguish the following cases:

- **Case 1: Delivery** of the drive system.  
According to the regulations, the product standard EN 61800-3 is complied with for Rexroth drive systems. The drive system is listed in the declaration of EMC conformity. This fulfills the legal requirements according to EMC directive.
- **Case 2: Acceptance test** of a machine or installation with the installed drive systems.  
The product standard for the respective type of machine/installation, if existing, applies to the acceptance test of the machine or installation. In the last years, some new product standards were created for certain machine types and some are being created at present. These new product standards contain references to the product standard EN 61800-3 for drives or specify higher-level requirements demanding increased filter and installation efforts. When the machine manufacturer wants to put the machine/installation into circulation, the product standard relevant to his machine/installation has to be complied with for his end product "machine/installation". The authorities and test laboratories responsible for EMC normally refer to this product standard.

This documentation specifies the EMC properties which can be achieved, in a machine or installation, with a drive system consisting of the standard components.

It also specifies the conditions under which the indicated EMC properties can be achieved.

## 10.3 Measures to Reduce Noise Emission

### 10.3.1 General Information

To reduce noise emission there are mainly three possible measures:

- filtering by means of mains filter
- shielding by mounting and shielded cables
- grounding by electrical bonding

#### Noise Emission of the Drive Systems

In order to comply with the limit values for noise emission (mainly line-based radio interference of more than 9 kHz) at the connection points of the machine or installation, observe the notes on application contained in this documentation.

### 10.3.2 Shielding

Sufficient metallic shielding prevents radiation into the air. This is achieved by mounting the devices in a grounded control cabinet or in a housing (metallic encapsulation). The shielding of line connections is realized by shielded cables and lines, the shield has to be grounded over a large surface area.

To connect the shield at the motor, a suitable PG gland with shield connection can be used (e.g. "SKINDICHT SHV/SRE/E" from the Lapp company, Stuttgart). Make sure that the connection between the motor terminal box and the motor housing has a low impedance. If necessary, use an additional grounding strap between them. Never use plastic motor terminal boxes!

### 10.3.3 Grounding

Grounding discharges interference to ground and makes it flow back to the source of interference over the shortest distance. Realize grounding via a sufficiently **short connection over the largest possible surface area** in order to achieve low inductive resistance with a low degree of line inductance. The higher the frequency of disturbances, the lower the line inductance of grounding has to be.



In ungrounded mains the measure "grounding" cannot be generally used.

### 10.3.4 Filtering

Filtering prevents emission of noise via the lines, especially via the mains connection. For this purpose, there are special interference suppression filters available with which

- the allowed limit values of the line-based interference emission can be complied with in the range of 50 kHz to 30 MHz.
- interference via the mains connection to devices connected near by (e.g. control unit components) can be reduced.



# 11 Arranging the Components in the Control Cabinet

## 11.1 Dimensions and Distances

### 11.1.1 Main Dimensions of the System Components

#### General Information



The **mounting depths** of the Rexroth IndraDrive product range have been optimized for mounting in control cabinets:

- mounting depths up to **265 mm**: for control cabinets with a depth of 300 mm
- mounting depths up to **322 mm**: for control cabinets with a depth of 400 mm

The figure below contains a rough overview of the main dimensions.



For other data and required mounting dimensions, see Project Planning Manual "Rexroth IndraDrive Supply Units and Power Sections" → Chapter of the respective device → "Technical Data" → "Mechanical System and Mounting"

#### Device Depths and Device Heights

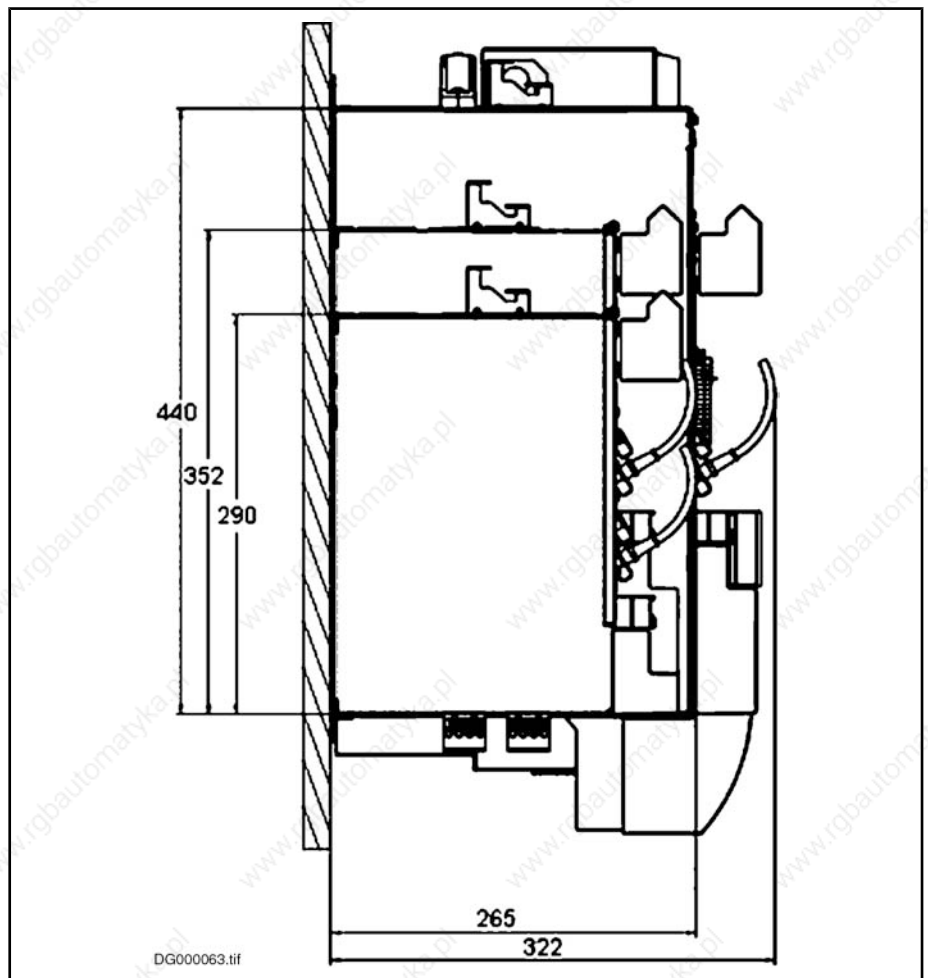

Fig. 11-1: Main dimensions in mm



Arranging the Components in the Control Cabinet

## 11.1.2 Distances

### General Information

In addition to the mounting dimensions, the devices of the Rexroth IndraDrive range require additional mounting clearance:

- to ventilate the devices
- to mount accessories and connections
- to take temperature limits of neighboring mounting parts, such as cable ducts etc., into account

For the required mounting clearance in the control cabinet, take additional distances between the devices and on their tops and bottoms into account.



For the distances to be complied with  $d_{top}$  (distance to top of device),  $d_{bot}$  (distance to bottom of device) and  $d_{hor}$  (distance to side of device), see Project Planning Manual "Rexroth IndraDrive Supply Units and Power Sections" → Chapter of the respective device → "Technical Data" → "Mechanical System and Mounting" → "Power Dissipation, Mounting Position, Cooling, Distances"

### Distance Between the Devices

Owing to power dissipation in the devices, especially due to integrated braking resistors, the temperatures of neighboring devices are rising. In the case of lateral mounting, trouble-free operation therefore requires the following minimum distances (in mm) between the devices.

Minimum distance [mm]						
between	and					
	HCS02	HCS03 (HNK01, HLR01)	HMV01	HMV02	HMS01 / HMD01	HMS02
HCS02.1E	5	--	--	--	0 (HMS to the right of HCS) 5 (HMS to the left of HCS)	0 (HMS to the right of HCS) 5 (HMS to the left of HCS)
HCS03.1E with HNK01 and HLR01	--	0	--	--	0	--
HMV01.1E / HMV01.1R	--	--	0	--	0	--
HMS01.1 / HMD01.1	0 (HMS to the right of HCS) 5 (HMS to the left of HCS)	0	0	--	0	--
HMV02.1R	--	--	--	--	--	0
HMS02.1	0 (HMS to the right of HCS) 5 (HMS to the left of HCS)	0	0	0	0	0

-- not allowed  
Fig. 11-2: Minimum distances



## Arranging the Components in the Control Cabinet



For arrangement of the devices in the control cabinet, take the required minimum distances into account besides the device dimensions.

**Distance to the Bottom of the Devices**

In order that there is sufficient cooling air available for cooling the devices, a minimum distance to other devices must be complied with from the bottom of the devices. This applies both to the intake space of devices with forced cooling and to devices with cooling by natural convection.

In the thermal steady-state condition of the drive system, the temperature at the **air intake** of the device is the ambient temperature of the device. The temperature at the air intake is relevant when you check whether the allowed ambient temperature range  $T_{a\_work}$  (see technical data of the respective device) has been complied with.



Keep the space at the air intake free from unnecessary barriers.

Run the cables as short as possible and without loops.

Do not place loads with power dissipation (e.g. mains chokes, braking resistors) near the air intake.

Use barrier plates, if necessary.

Form a **channel** which is as obstacle-free as possible and corresponds at least to the cross section " $d_{bot} \times$  mounting depth". The channel should lead with at least this cross section to the air intakes at the bottom and at the top of the devices.



If there are different minimum distances for the individual devices in a drive system, the greatest value determines the minimum distance to be observed for the entire row in the drive system.

**Distance to the Top of the Devices**

In order that the cooling systems can transport the cooling air through the devices and heat does not accumulate, a minimum distance to the top of the devices must be complied with.



Keep the space at the air outlet free from unnecessary barriers.

Where possible, run the cables and lines outside the outlet apertures.

The supplied cooling air is heated up due to the power dissipation generated in the devices.

In a distance of  $d_{top}$  above the devices, the temperature of the cooling air is up to 105 °C.

Directly at the outlet apertures – especially of devices with integrated braking resistor – the temperature of the cooling air can be significantly higher than 105 °C.

**CAUTION**

**Property damage due to temperatures higher than 105 °C!**

Comply with indicated minimum distances!

Arranging the Components in the Control Cabinet

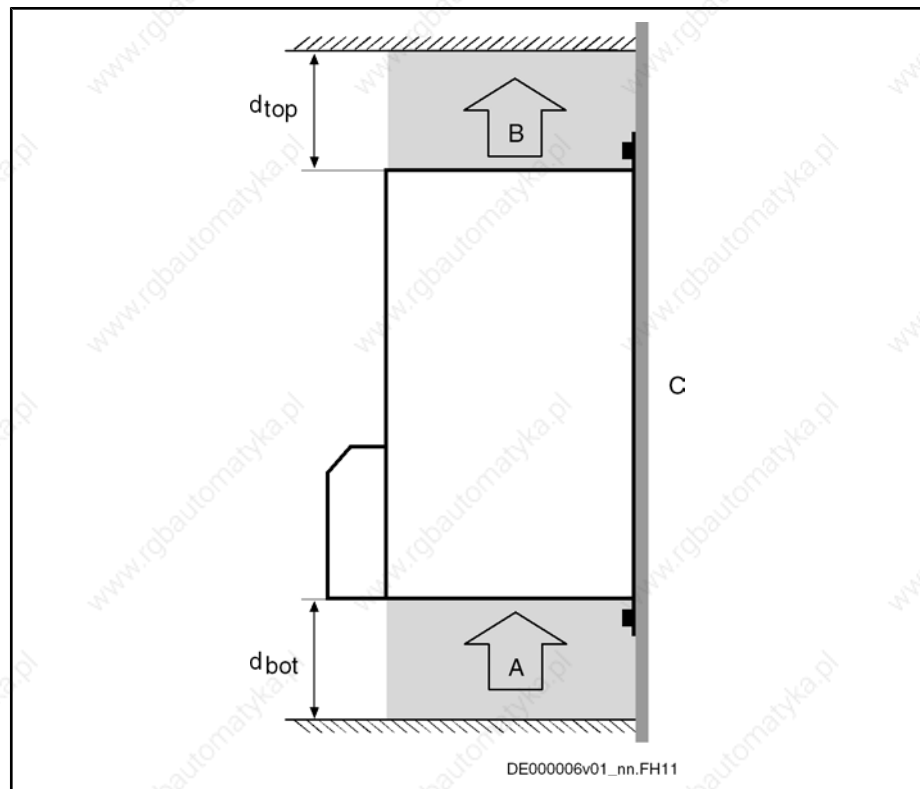

- A air intake
- B air outlet
- C mounting surface in control cabinet
- $d_{top}$  distance to top of device
- $d_{bot}$  distance to bottom of device

Fig. 11-3: Air intake and air outlet at drive controller



If there are different minimum distances for the individual devices in a drive system, the greatest value determines the minimum distance to be observed for the entire row in the drive system.

For example, if a supply unit with integrated braking resistor is used and operated with nominal power, its minimum distance  $d_{top}$  of for example 300 mm determines the minimum distance for the connected HMS / HMD drive controllers, see figure "Minimum distance at HMV supply units".

**Minimum Distance of HMV Supply Units**

The braking resistor in HMV01.1E heats up during operation, the braking resistor in HMV01.1R and HMV02.1R does so particularly after power has been switched off.

Under rated load, the escaping cooling air has cooled down in the minimum distance to below 105 °C. If the integrated braking resistor is not loaded, the distance can be reduced to 80 mm.

## Arranging the Components in the Control Cabinet

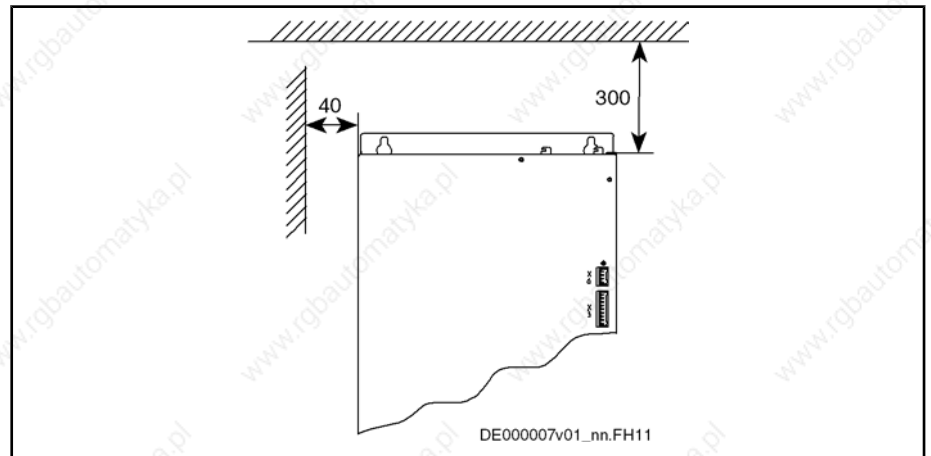

Fig. 11-4: Minimum distance at HMV supply units

### Lateral Distance at Drive System

In order that the cooling air can circulate in the closed control cabinet, a distance at the sides of the drive system is required in addition to the distances at the top and at the bottom.

In the closed control cabinet, the circulation is provoked by the natural convection and supported by the device-internal blowers.

Arranging the Components in the Control Cabinet

### 11.1.3 Boring Dimensions for the Mounting Plate Individually Arranged Devices

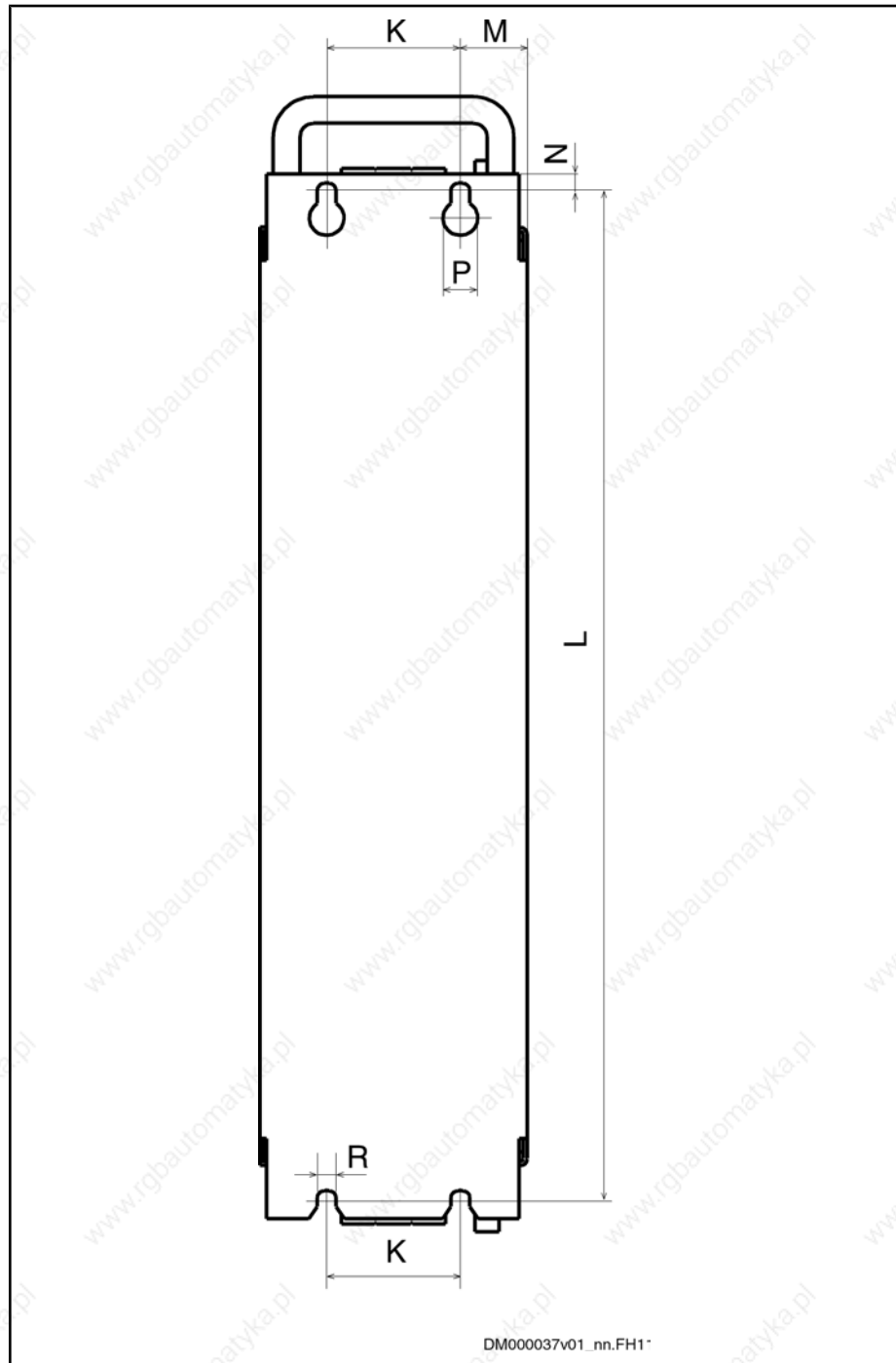

Fig. 11-5: Boring dimensions



The figure shows the back of a device.

## Arranging the Components in the Control Cabinet

Device	K [mm]	L [mm]	M [mm]	P [mm]	R [mm]	Notes
HCS02.1E-W0012	0	316	32,5	13	7	observe additional distance to lateral neighboring devices
HCS02.1E-W0028	0	378	32,5	13	7	observe additional distance to lateral neighboring devices
HCS02.1E-W0054	55	378	25	13	7	observe additional distance to lateral neighboring devices
HCS02.1E-W0070	55	378	25	13	7	observe additional distance to lateral neighboring devices
HCS03.1E-W0070	75	466	25	13	7	
HCS03.1E-W0100	175	466	25	13	7	
HCS03.1E-W0150	175	466	25	13	7	
HCS03.1E-W0210	250	466	50	13	7	
HMV01.1E-W0030	100	466	25	13	7	
HMV01.1E-W0075	200	466	25	13	7	
HMV01.1E-W0120	300	466	25	13	7	
HMV01.1R-W0018	125	466	25	13	7	
HMV01.1R-W0045	200	466	25	13	7	
HMV01.1R-W0065	300	466	25	13	7	
HMV02.1R-W0015	100	378	25	13	7	
HMS01.1N-W0020	0	466	25	13	7	
HMS01.1N-W0036	0	466	25	13	7	
HMS01.1N-W0054	0	466	25	13	7	
HMS01.1N-W0070	50	466	25	13	7	
HMS01.1N-W0150	100	466	25	13	7	
HMS01.1N-W0210	150	466	25	13	7	
HMS02.1N-W0028	0	378	25	13	7	
HMS02.1N-W0054	0	378	25	13	7	
HMD01.1N-W0012	0	466	25	13	7	
HMD01.1N-W0020	0	466	25	13	7	
HMD01.1N-W0036	0	466	25	13	7	
HNL02.1	100	378	20	13	7	
HNS02.1	0	378	55	13	7	
HLB01.1C	0	378	32,5	13	7	
HLB01.1D	50	466	25	13	7	
HLC01.1C-01M0	0	378	25	13	7	

Arranging the Components in the Control Cabinet

Device	K [mm]	L [mm]	M [mm]	P [mm]	R [mm]	Notes
HLC01.1C-02M4	0	378	25	13	7	
HLC01.1D-05M0	0	466	25	13	7	

Fig. 11-6: Boring dimensions

**Ground the housings of the devices!**

1. Connect the bare metal back panel of the device in conductive form to the mounting surface in the control cabinet.
2. Use the supplied mounting screws and fix the screws with a tightening torque of typically 6 Nm.
3. Connect the mounting surface of the control cabinet in conductive form to the equipment grounding system.

**Combination of Devices of the Rexroth IndraDrive M Product Range**

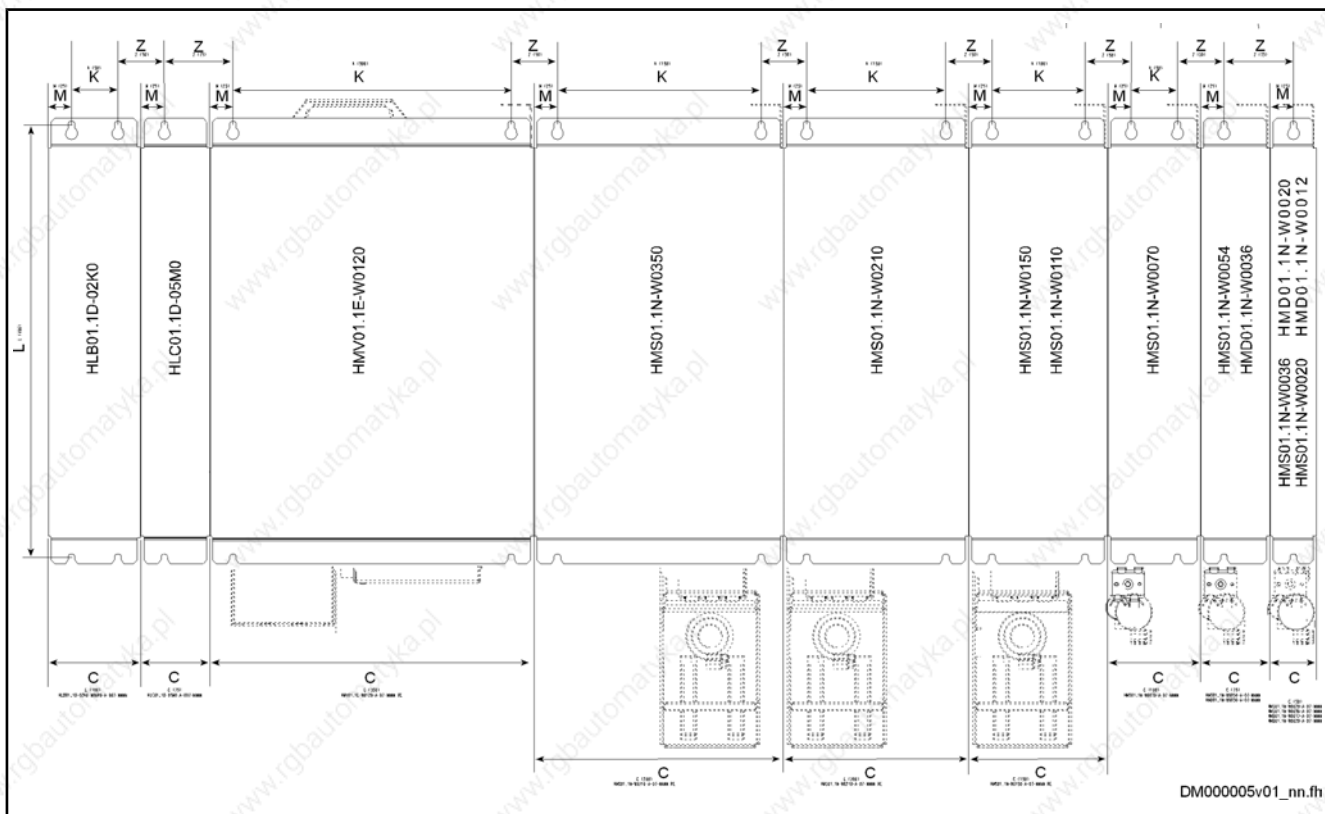

Fig. 11-7: Rexroth IndraDrive M devices



The prevailing grid of fixing bores within the Rexroth IndraDrive M product range is **25 mm**.

Arrange the drive controllers with high capacity as close to the supplying unit as possible.

The **HAS02** accessories in the figure require additional downward mounting clearance.

**Dimension Z** is significantly determined by the involved devices. The table below contains the dimensions Z between the device arranged to the left and the device arranged to the right.

## Arranging the Components in the Control Cabinet

Device left	Device right	Dimension Z [mm]
HMV01.1E-W0030 HMV01.1E-W0075 HMV01.1E-W0120 HMV01.1R-W0018 HMV01.1R-W0045 HMV01.1R-W0065 HMS01.1N-W0020 HMS01.1N-W0036 HMS01.1N-W0070 HMS01.1N-W0110 HMS01.1N-W0150 HMS01.1N-W0210 HMS01.1N-W0350 HMD01.1N-W0012 HMD01.1N-W0020	HMS01.1N-W0020 HMS01.1N-W0036 HMS01.1N-W0054 HMS01.1N-W0070 HMS01.1N-W0110 HMS01.1N-W0150 HMS01.1N-W0210 HMS01.1N-W0350 HMD01.1N-W0012 HMD01.1N-W0020 HMD01.1N-W0036 HLC01.1D-05M0 HLB01.1D	50
HMS01.1N-W0054 HMD01.1N-W0036 HLC01.1D-05M0	HMV01.1E-W0030 HMV01.1E-W0075 HMV01.1E-W0120 HMV01.1R-W0018 HMV01.1R-W0045 HMV01.1R-W0065 HMS01.1N-W0020 HMS01.1N-W0036 HMS01.1N-W0070 HMS01.1N-W0110 HMS01.1N-W0150 HMS01.1N-W0210 HMS01.1N-W0350 HMD01.1N-W0012 HMD01.1N-W0020 HLC01.1D-05M0 HLB01.1D	75



Arranging the Components in the Control Cabinet

Device left	Device right	Dimension Z [mm]
HLC01.1C-01M0 HLC01.1C-02M4	HMV01.1E-W0030 HMV01.1E-W0075 HMV01.1E-W0120 HMV01.1R-W0018 HMV01.1R-W0045 HMV01.1R-W0065 HMS01.1N-W0020 HMS01.1N-W0036 HMS01.1N-W0070 HMS01.1N-W0110 HMS01.1N-W0150 HMS01.1N-W0210 HMS01.1N-W0350 HMD01.1N-W0012 HMD01.1N-W0020 HLC01.1D-05M0 HLB01.1D	57,5
HLC01.1C-01M0 HLC01.1C-02M4	HLC01.1C-01M0 HLC01.1C-02M4	65

Fig. 11-8: Table for dimension Z

## Combination of Drive Controllers of the Rexroth IndraDrive C Product Range

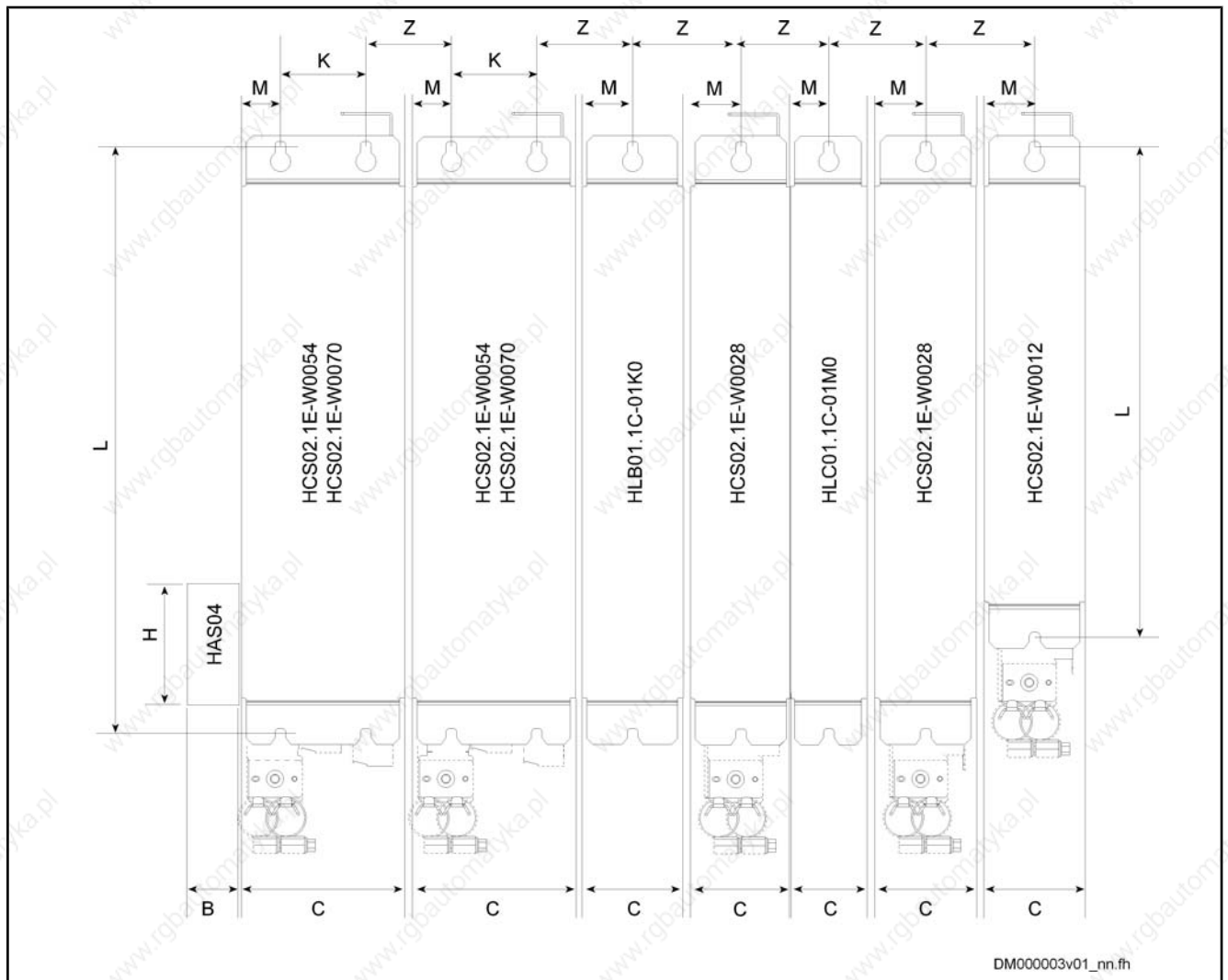

Fig. 11-9: Rexroth IndraDrive C devices



The accessory **HAS04** requires additional mounting clearance at the HCS arranged at the utmost left position.

Rexroth IndraDrive devices are arranged in line **to the right** starting from the supplying device. Arrange the drive controllers with high capacity as close to the supplying unit as possible.

The **HAS02** accessories in the figure require additional downward mounting clearance.

**Dimension Z** is significantly determined by the involved devices. The table below contains the dimensions **Z** between the device arranged to the left and the device arranged to the right.

Arranging the Components in the Control Cabinet

Device left	Device right	Dimension Z [mm]
HCS02.1E-W0012 HCS02.1E-W0028 HLB01.1C	HCS02.1E-W0012 HCS02.1E-W0028 HLB01.1C	70
HCS02.1E-W0054 HCS02.1E-W0070	HCS02.1E-W0054 HCS02.1E-W0070	55
HLC01.1C-01M0 HLC01.1C-02M4 HCS02.1E-W0054 HCS02.1E-W0070	HLC01.1C-01M0 HLC01.1C-02M4	50 (without distance between the devices)
HCS02.1E-W0012 HCS02.1E-W0028 HLB01.1C	HLC01.1C-01M0 HLC01.1C-02M4	57,5 (without distance between the devices)
HCS02.1E-W0054 HCS02.1E-W0070 HLC01.1C-01M0 HLC01.1C-02M4	HCS02.1E-W0012 HCS02.1E-W0028 HLB01.1C	62,5
HCS03.1E-W0070 HCS03.1E-W0100 HCS03.1E-W0150	HCS03.1E-W0070 HCS03.1E-W0100 HCS03.1E-W0150	50 (without distance between the devices)
HCS03.1E-W0210	HCS03.1E-W0210	100 (without distance between the devices)
HCS03.1E-W0070 HCS03.1E-W0100 HCS03.1E-W0150	HCS03.1E-W0210	75 (without distance between the devices)
HCS03.1E-W0210	HCS03.1E-W0070 HCS03.1E-W0100 HCS03.1E-W0150	75 (without distance between the devices)

Fig. 11-10: Table for dimension Z

Combination of Drive Controllers of the Rexroth IndraDrive C and IndraDrive M Product Ranges



The accessory **HAS04** requires additional mounting clearance at the HCS arranged at the utmost left position.

Rexroth IndraDrive M devices are arranged in line **to the right** starting from the supplying drive controller HCS.

**Dimension Z** is significantly determined by the involved devices. The table below contains the dimensions Z between the device arranged to the left and the device arranged to the right.

## Arranging the Components in the Control Cabinet

## HCS02 Drive Controllers

Device left	Device right	Dimension Z [mm]
HCS02.1E-W0054 HCS02.1E-W0070	HMS01.1N-W0020 HMS01.1N-W0036 HMS01.1N-W0054 HMS02.1N-W0028 HMS02.1N-W0054 HMD01.1N-W0012 HMD01.1N-W0020 HMD01.1N-W0036 HLC01.1D-05M0 HLB01.1D	50 (without distance between the devices)

Fig. 11-11: Table for dimension Z

## HCS03 Drive Controllers

Device left	Device right	Dimension Z [mm]
HCS03.1E-W0070 HCS03.1E-W0100 HCS03.1E-W0150	HMS01.1N-W0020 HMS01.1N-W0036 HMS01.1N-W0054 HMS01.1N-W0070 HMD01.1N-W0012 HMD01.1N-W0020 HMD01.1N-W0036	50 (without distance between the devices)
HCS03.1E-W0210	HMS01.1N-W0020 HMS01.1N-W0036 HMS01.1N-W0054 HMS01.1N-W0070 HMS01.1N-W0110 HMS01.1N-W0150 HMD01.1N-W0012 HMD01.1N-W0020 HMD01.1N-W0036	75 (without distance between the devices)

Fig. 11-12: Table for dimension Z



For the dimensions Z between other combinations see previous tables.

## 11.2 Arranging Components From Electrical Point of View

### 11.2.1 General Information

The section below contains information and recommendations on the arrangement of the devices in the control cabinet from mainly electrical points of view. These points of view include aspects of performance-dependent arrangement and electromagnetically compatible installation.

## Arranging the Components in the Control Cabinet

### 11.2.2 Performance-Dependent Arrangement

**Arrangement With HMV** The **HMV01** supply units can supply HMS and HMD drive controllers **on both sides**.



When you use HNS02 and HNL02, the supply units **HMV02** only allow mounting them on one side to the **right**.

- Arrange drive controllers according to their performance. Arrange drive controllers with high performance as close to the supply unit as possible. Ideally the drive controllers should be distributed equally to the left and right side of the supply unit.
- Arrange DC bus capacitor unit (HLC) next to the supply unit.
- Arrange DC bus resistor unit (HLB) next to the supply unit.
- When simultaneously using DC bus resistor unit and DC bus capacitor unit in a drive system, arrange the DC bus capacitor unit between supply unit and DC bus resistor unit.

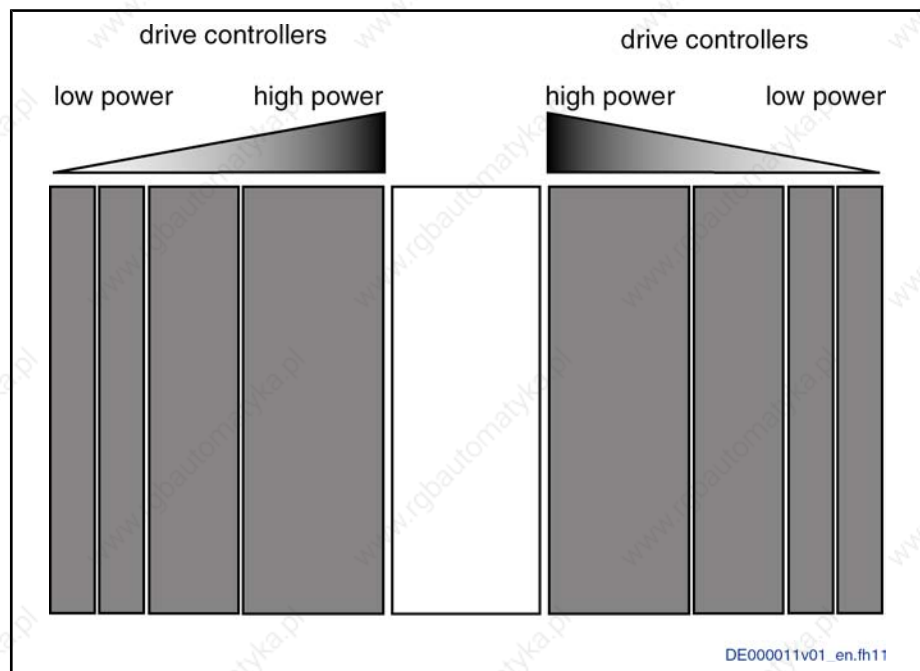

Fig.11-13: Example of an arrangement

**Arrangement With HCS** When you operate **HCS** converters in the type of mains connection "central supply", place the supplied drive controllers to the **right** of the HCS converters.

- Arrange DC bus capacitor unit next to drive controller with the greatest DC bus continuous power.
- Arrange DC bus resistor unit next to drive controller with the greatest regenerative power.
- When simultaneously using DC bus resistor unit and DC bus capacitor unit in a drive system, arrange the DC bus capacitor unit to the right of HCS and the DC bus resistor unit to the right of the DC bus capacitor unit.
- Arrange HLR braking resistors in "standard" design above the HCS03 drive controller.

## 11.2.3 EMC Measures for Design and Installation

### Rules for Design of Installations With Drive Controllers in Compliance with EMC

The following rules are the basics for designing and installing drives in compliance with EMC.

<b>Mains Filter</b>	Correctly use a mains filter recommended by Rexroth for radio interference suppression in the supply feeder of the drive system.
<b>Control Cabinet Grounding</b>	Connect all metal parts of the cabinet with one another over the largest possible surface area to establish a good electrical connection. This, too, applies to the mounting of the EMC filter. If required, use serrated washers which cut through the paint surface. Connect the cabinet door to the control cabinet using the shortest possible grounding straps.
<b>Line Routing</b>	<ul style="list-style-type: none"> <li>• Avoid coupling routes between lines with high potential of noise and noise-free lines; therefore signal, mains and motor lines and power cables have to be routed separately from another. Minimum distance: 10 cm. Provide separating sheets between power and signal lines. Ground separating sheets several times.</li> <li>• The lines with high potential of noise include: <ul style="list-style-type: none"> <li>– at the drive controller the lines at the mains connection (incl. synchronization connection)</li> <li>– the lines at the motor connection and the connections at the DC bus</li> </ul> </li> <li>• Generally, interference injection are reduced by routing cables close to grounded sheet steel plates. For this reason, cables and wires should not be routed freely in the cabinet, but close to the cabinet housing or mounting panels. Separate the incoming and outgoing cables of the radio interference suppression filter.</li> </ul>
<b>Interference Suppression Elements</b>	<p>Provide the following components in the control cabinet with interference suppression combinations:</p> <ul style="list-style-type: none"> <li>• contactors</li> <li>• relays</li> <li>• solenoid valves</li> <li>• electromechanical operating hour counters</li> </ul> <p>Connect these combinations directly at each coil.</p>
<b>Twisted Wires</b>	Twist unshielded wires belonging to the same circuit (feeder and return cable) or keep the surface between feeder and return cable as small as possible. Ground wires that are not used at both ends.
<b>Lines of Measuring Systems</b>	Lines of measuring systems must be shielded. Connect the shield to ground at both ends and over the largest possible surface area. The shield may not be interrupted, e.g. using intermediate terminals.
<b>Digital Signal Lines</b>	Ground the shields of digital signal lines at both ends (transmitter <b>and</b> receiver) over the largest possible surface area and with low impedance. In the case of bad ground connection between transmitter and receiver, additionally route a bonding conductor (min. 10 mm <sup>2</sup> ). Braided shields are better than foil shields.
<b>Analog Signal Lines</b>	Ground the shields of analog signal lines at one end (transmitter <b>or</b> receiver) over the largest possible surface area and with low impedance. This avoids low-frequency interference current (in the mains frequency range) on the shield.
<b>Connection of Mains Choke</b>	Keep connection lines of the mains choke at the drive controller as short as possible and twist them.
<b>Installation of Motor Power Cable</b>	<ul style="list-style-type: none"> <li>• Preferably use Rexroth's motor power cables with shield. If you use other motor power cables, they have to be run in shielded form.</li> </ul>

## Arranging the Components in the Control Cabinet

- Keep length of motor power cable as short as possible.
- Ground shield of motor cable at both ends over the largest possible surface area to establish a good electrical connection.
- Run motor lines in shielded form inside the control cabinet.
- Do not use any steel-shielded lines.
- The shield of the motor cable mustn't be interrupted by mounted components, such as output chokes, sine filters, motor filters.

## 11.2.4 EMC-Optimal Installation in Facility and Control Cabinet

### General Information

For EMC-optimal installation, a spatial separation of the interference-free area (mains connection) and the interference-susceptible area (drive components) is recommended, as shown in the figures below.



For EMC-optimal installation in the control cabinet, use a separate control cabinet panel for the drive components.

### Division Into Areas (Zones)

Exemplary arrangements in the control cabinet: see section [Control Cabinet Mounting According to Interference Areas - Exemplary Arrangements](#), page 161.

We distinguish three areas:

#### 1. Interference-free area of control cabinet (**area A**):

This includes:

- supply feeder, input terminals, fuse, main switch, mains side of mains filter for drives and corresponding connecting lines
- control voltage or auxiliary voltage connection with power supply unit, fuse and other parts unless connection is run via the mains filter of the AC drives
- all components that aren't electrically connected with the drive system

#### 2. Interference-susceptible area **area B**:

- mains connections between drive system and mains filter for drives, mains contactor
- interface lines of drive controller

#### 3. Strongly interference-susceptible area **area C**:

- motor cable including single strands

Never run lines of one of these areas in parallel with lines of another area so that there isn't any unwanted interference injection from one area to the other and that the filter is jumpered with regard to high frequency. Keep connection lines as short as possible.

Recommendation for complex systems: Install drive components in one cabinet and the control units in a second, separate cabinet.

Badly grounded control cabinet doors act as antennas. Therefore, connect the control cabinet doors to the cabinet on top, in the middle and on the bottom via short equipment grounding conductors with a cross section of at least 6 mm<sup>2</sup> or, even better, via grounding straps with the same cross section. Make sure connection points have good contact.



## Control Cabinet Mounting According to Interference Areas - Exemplary Arrangements

### Supply Units With Regeneration



**Do not operate any additional loads at the mains filter!**

Do not operate any other loads at the connection from the mains filter output to the mains connection of the supply unit.

For motor blowers and power supply units, for example, use separate mains filters.

Arranging the Components in the Control Cabinet

HMVxx.xR supply unit

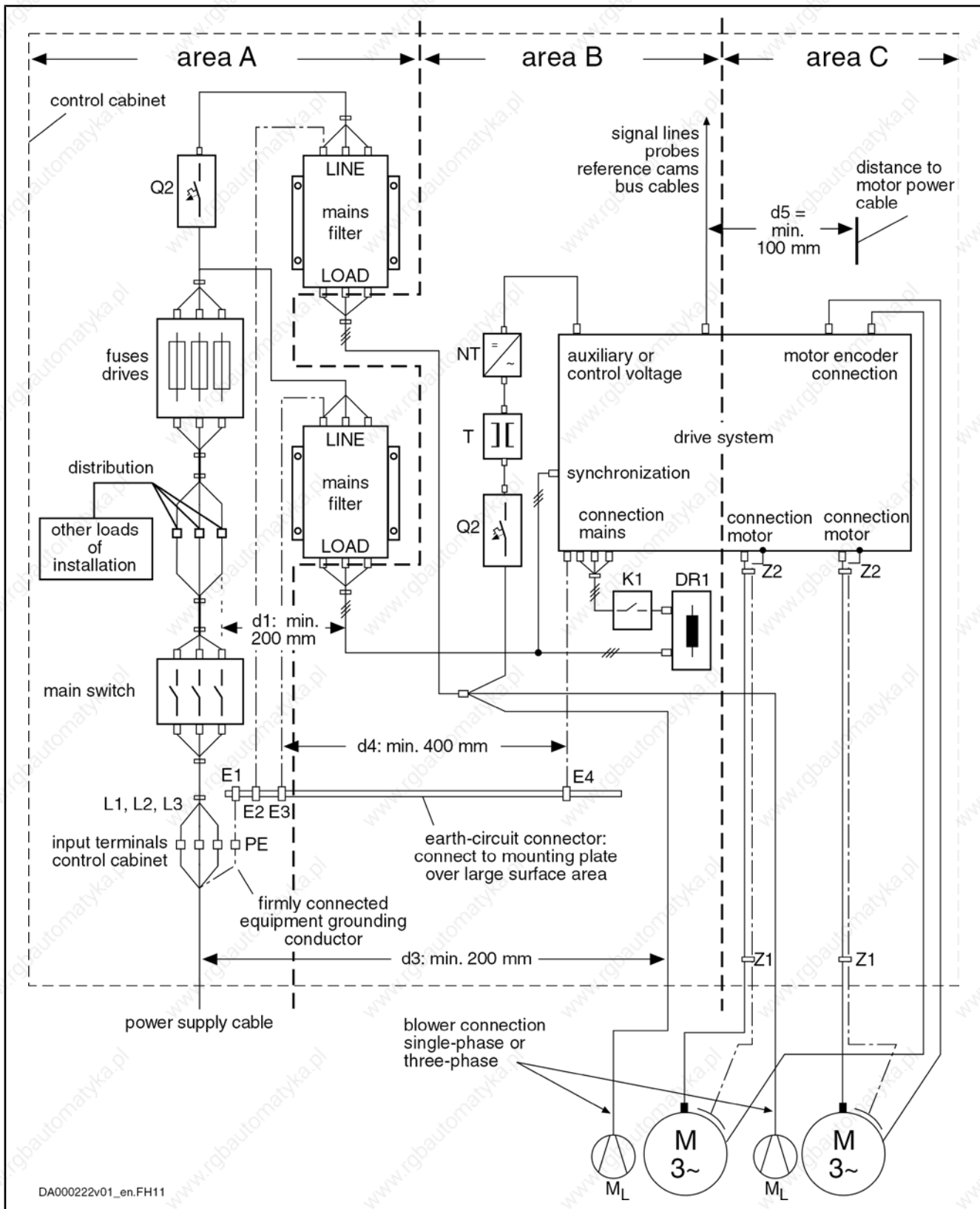

DA000222v01\_en.FH11

- |                |  |
|----------------|--|
| DR1            | mains choke  |
| K1             | external mains contactor for supply units without integrated mains contactor |
| M <sub>L</sub> | motor blower   |
| NT             | power supply unit  |
| Q2             | fuse   |
| T              | transformer  |
| Z1, Z2         | shield connection points for cable   |

Fig.11-14: HMVxx.xR - EMC areas in the control cabinet

Arranging the Components in the Control Cabinet

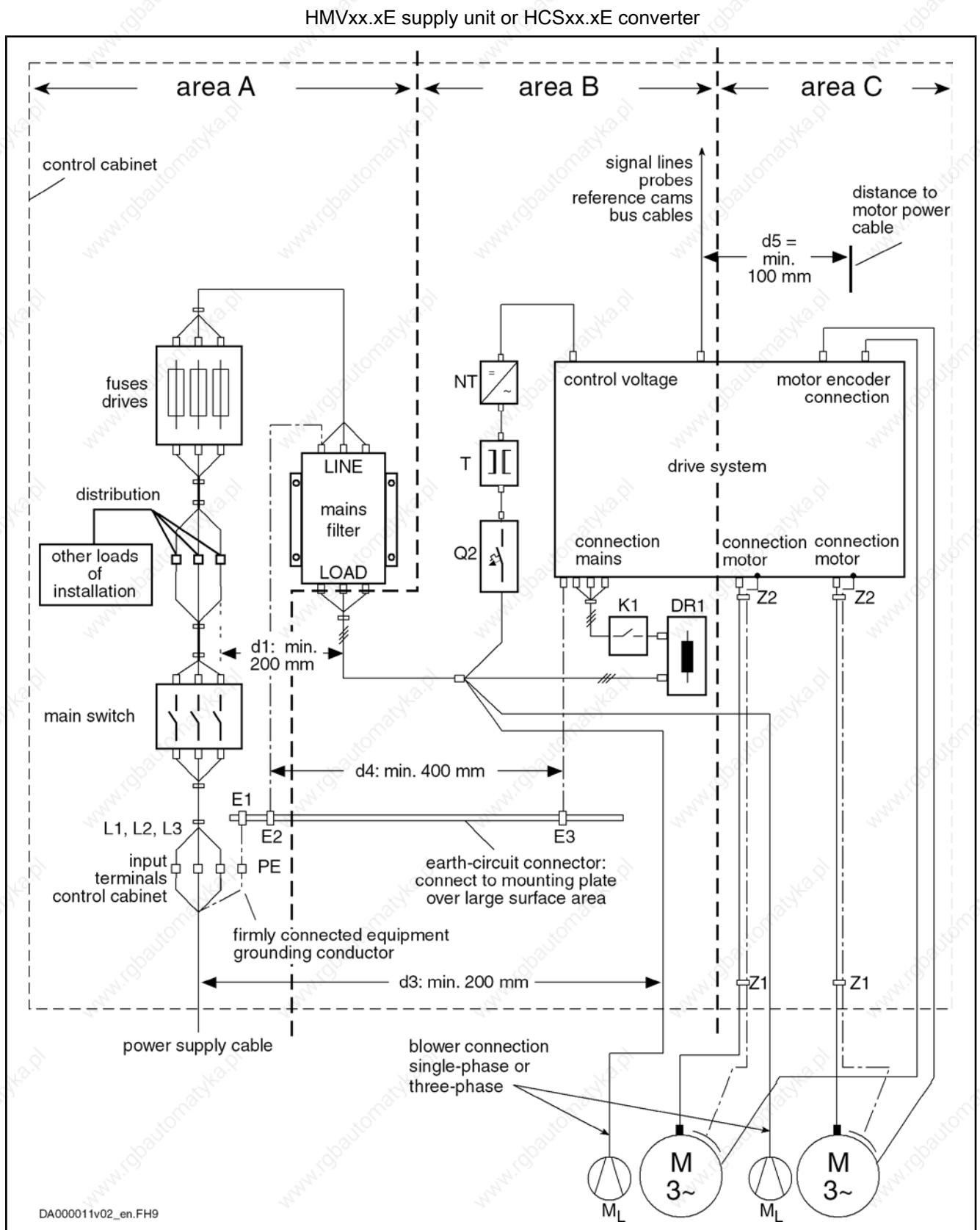

- DR1 mains choke (optional)
  - K1 external mains contactor for supply units and converters without integrated mains contactor
  - ML motor blower
  - NT power supply unit
  - Q2 fuse
  - T transformer
  - Z1, Z2 shield connection points for cable
- Fig. 11-15: HMVxx.xE; HCSxx.xE - EMC areas in the control cabinet

## Arranging the Components in the Control Cabinet

## Design and Installation in Area A - Interference-Free Area of Control Cabinet

## Arranging the Components in the Control Cabinet

Comply with a distance of at least **200 mm** (distance d1 in the figure):

between components and electrical elements (switches, pushbuttons, fuses, terminal connectors) in the interference-free area A and the components in the two other areas B and C

Comply with a distance of at least **500 mm**:

between magnetic components (such as transformers, mains chokes and DC bus chokes that are directly connected to the power connections of the drive system) and the interference-free components and lines between mains and filter including the mains filter in area A

If this distance is not kept, the magnetic leakage fields are injected to the interference-free components and lines connected to the mains so that the limit values at the supply connection are exceeded in spite of the installed filter.

## Cable Routing of the Interference-Free Lines to the Mains Connection

Comply with a distance of at least **200 mm** (distance d1 and d3 in the figure):

between supply feeder or lines between filter and exit point from the control cabinet in area A and the lines in area B and C

If this is impossible, there are two alternatives:

1. Install lines in shielded form and connect the shield at several points (at least at the beginning and at the end of the line) to the mounting plate or the control cabinet housing over a large surface area.
2. Separate lines from the other interference-susceptible lines in areas B and C by means of a grounded distance plate vertically attached to the mounting plate.

Keep lines as short as possible within the control cabinet and install them directly on the grounded metal surface of the mounting plate or of the control cabinet housing.

Mains supply lines from areas B and C must not be connected to the mains without a filter.



In case the information on cable routing given in this section is not observed, the effect of the mains filter is totally or partly neutralized. You must then expect the noise level of the interference emission to be higher within the range of 150 kHz to 40 MHz and the limit values at the connection points of the machine or installation to be exceeded.

## Routing and Connecting a Neutral Conductor (N)

If a neutral conductor is used together with a three-phase connection, it must not be installed unfiltered in zones B and C, in order to keep interference off the mains.

## Motor Blower at Mains Filter

Single-phase or three-phase supply lines of motor blowers, that are usually routed in parallel with motor cables or interference-susceptible lines, must be filtered:

- in drive systems with **regenerative supply units**, via a separate single-phase (NFE type) or three-phase filter (HNF, NFD type) near the mains connection of the control cabinet
- in drive systems with **only infeeding supply units**, via the available three-phase filter of the drive system

When switching power off, make sure the blower is not switched off.

## Arranging the Components in the Control Cabinet

**Loads at Mains Filter of Drive System****Only operate allowed loads at the mains filter of the drive system!**

At the three-phase filter for the power connection of regenerative supply units, it is only allowed to operate the following loads:

- HMV supply unit with mains choke and, if necessary, mains contactor

Do not operate any motor blowers, power supply units etc. at the mains filter of the drive system.

**Shielding Mains Supply Lines in Control Cabinet**

If there is a high degree of interference injection to the mains supply line within the control cabinet, although you have observed the above instructions (to be found out by EMC measurement according to standard), proceed as follows:

- only use shielded lines in area A
- connect shields to the mounting plate at the beginning and the end of the line by means of clips

The same procedure may be required for long cables of more than 2 m between the point of power supply connection of the control cabinet and the filter within the control cabinet.

**Mains Filters for AC Drives**

Ideally, mount the mains filter on the parting line between area A and B. Make sure the ground connection between filter housing and housing of the drive controllers has good electrically conductive properties.

If single-phase loads are connected on the load side of the filter, their current may only be a maximum of 10% of the three-phase operating current. A highly imbalanced load of the filter would deteriorate its interference suppression capacity.

If the mains voltage is more than 480 V, connect the filter to the output side of the transformer and not to the supply side of the transformer.

**Grounding**

In the case of bad ground connections in the installation, the distance between the lines to the grounding points E1, E2 in area A and the other grounding points of the drive system should be at least  $d_4 = 400 \text{ mm}$ , in order to minimize interference injection from ground and ground cables to the power input lines.

See also [Division Into Areas \(Zones\)](#), page 160.

**Point of Connection for Equipment Grounding Conductor at Machine, Installation, Control Cabinet**

The equipment grounding conductor of the power cable of the machine, installation or control cabinet has to be **firmly connected** at point PE and have a **cross section of at least  $10 \text{ mm}^2$**  or to be complemented by a second equipment grounding conductor via separate terminal connectors (according to EN50178/1997, section 5.3.2.1). If the cross section of the outer conductor is bigger, the cross section of the equipment grounding conductor must be accordingly bigger.

**Design and Installation in Area B - Interference-Susceptible Area of Control Cabinet****Arranging Components and Lines**

Modules, components and lines in area B should be placed at a distance of at least  $d_1 = 200 \text{ mm}$  from modules and lines in area A.

Alternative: Shield modules, components and lines in area B by distance plates mounted vertically on the mounting plate from modules and lines in area A or use shielded lines.

Only connect power supply units for auxiliary or control voltage connections in the drive system to the mains via a mains filter. See [Division Into Areas \(Zones\)](#), page 160.

Keep the length of the lines between drive controller and filter as short as possible.

**Control Voltage or Auxiliary Voltage Connection**

Only in exceptional cases should you connect power supply unit and fusing for the control voltage connection to phase and neutral conductor. In this case,

## Arranging the Components in the Control Cabinet

mount and install these components in area A far away from the areas B and C of the drive system. For details see section [Design and Installation in Area A - Interference-Free Area of Control Cabinet](#), page 164.

Run the connection between control voltage connection of the drive system and power supply unit used through area B over the shortest distance.

### Line Routing

Run the lines along grounded metal surfaces, in order to minimize radiation of interference fields to area A (transmitting antenna effect).

## Design and Installation in Area C - Strongly Interference-Susceptible Area of Control Cabinet

Area C mainly concerns the motor cables, especially at the connection point at the device.

### Influence of the Motor Power Cable

The discharge capacitance is limited to ensure compliance with the limit values. For the calculation of the discharge capacitance, see chapter [16 Calculations](#), page 319.

Keep the length of the cables as short as possible.

### Routing the Motor Cables

Only use shielded motor cables.

Route the motor cables with a distance of  $d_5 = 100 \text{ mm}$  to the other interference-free lines, as well as to signal cables and signal lines. Alternative: Route motor cables separated by a grounded distance plate. This is not necessary for the feedback cables to the Rexroth motors.

At the drive controller connection, route the motor lines and the (unfiltered) mains connection lines **in parallel for a maximum distance of 300 mm**. After that distance, route motor cables and power supply cables in opposite directions in separate **cable ducts** (see following figures with the example of a drive system with separate mains connection per drive axis IndraDrive HCS).

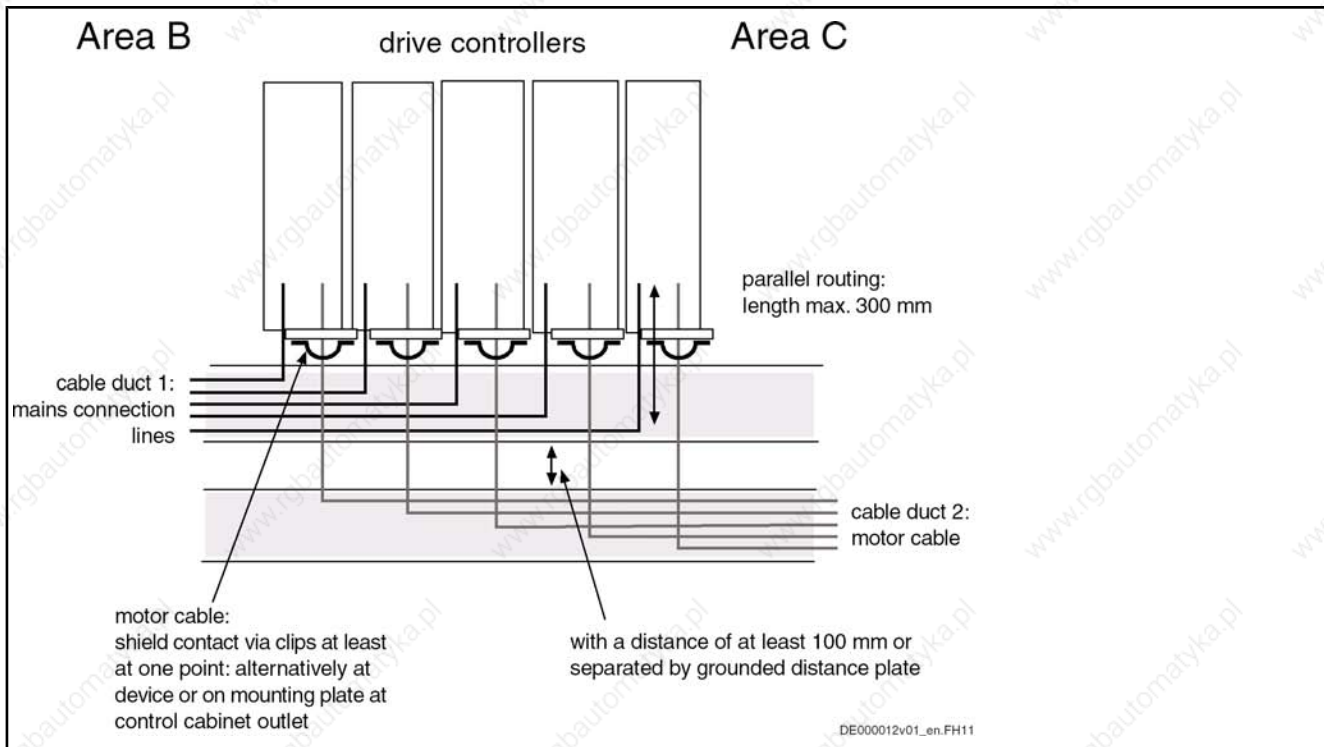

Fig. 11-16: Option 1: separate routing of motor cable and mains connection lines via 2 cable ducts



## Arranging the Components in the Control Cabinet

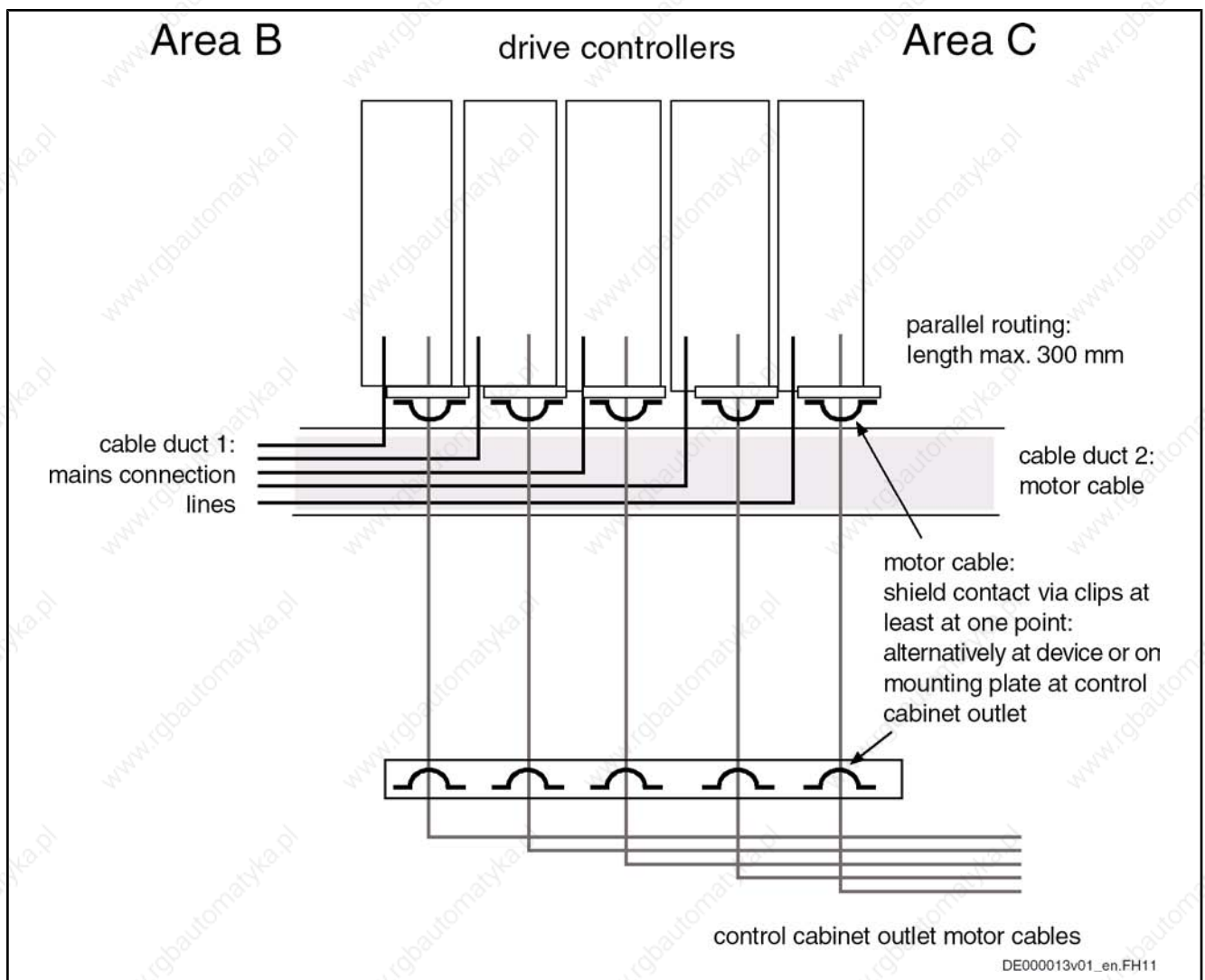

Fig. 11-17: Option 2: separate routing of motor cable and mains connection lines

#### Additional Recommendations for Cable Routing

Route the motor cables along grounded metal surfaces, both inside the control cabinet and outside of it, in order to minimize radiation of interference fields. If possible, route the motor cables in metal-grounded cable ducts.

Ideally, the outlet of the motor cables at the control cabinet should be provided in a distance of at least  $d3 = 200 \text{ mm}$  from the (filtered) power supply cable.

## 11.2.5 Ground Connections

### Housing and Mounting Plate

By means of appropriate ground connections, it is possible to avoid the emission of interference, because interference is discharged to ground on the shortest possible way.

Ground connections of the metal housings of EMC-critical components (such as filters, devices of the drive system, connection points of the cable shields, devices with microprocessor and switching power supply units) have to be well contacted over a large surface area. This also applies to all screw connections between mounting plate and control cabinet wall and to the mounting of a ground bus to the mounting plate.

The best solution is to use a zinc-coated or chromated mounting plate. Compared to a lacquered plate, the connections in this case have a good long-time stability.



## Arranging the Components in the Control Cabinet

**Connection Elements** For lacquered mounting plates, always use screw connections with tooth lock washers and zinc-coated, tinned screws as connection elements. At the connection points, scratch off the lacquer so that there is safe electrical contact over a large surface area. You achieve contact over a large surface area by means of bare connection surfaces or several connection screws. For screw connections, you can establish the contact to lacquered surfaces by using tooth lock washers.

**Metal Surfaces** Always use connection elements (screws, nuts, plain washers) with good electroconductive surface.

Bare zinc-coated, tinned and chromated metal surfaces have **good electroconductive properties**. Anodized, yellow chromated, black gunmetal finish or lacquered metal surfaces have **bad electroconductive properties**.

**Ground Wires and Shield Connections** For connecting ground wires and shield connections, it is not the cross section but the size of contact surface that is important, as the high-frequency interference currents mainly flow on the surface of the conductor.

Always connect cable shields, especially shields of the motor power cables with ground potential over a large surface area.

## 11.2.6 Installing Signal Lines and Signal Cables

**Line Routing** For measures to prevent interference, see the Project Planning Manuals of the respective device. In addition, we recommend the following measures:

Route signal and control lines separately from the power cables with a minimum distance of  $d_5 = 100 \text{ mm}$  (see [Division Into Areas \(Zones\)](#), page 160) or with a grounded separating sheet. The optimum way is to route them in separate cable ducts. If possible, lead signal lines into control cabinet at one point only.

Exception: If there is no other way to do it, motor feedback cables can be routed together with the motor power cables.

If signal lines are crossing power cables, route them in an angle of  $90^\circ$  in order to avoid interference injection.

Ground spare cables, that are not used and have been connected, at least at both ends so that they don't have any antenna effect.

Avoid unnecessary line lengths.

Run cables as close as possible to grounded metal surfaces (reference potential). The ideal solution are closed, grounded cable ducts or metal pipes which, however, is only obligatory for high requirements (sensitive instrument leads).

Avoid suspended lines or lines routed along synthetic carriers, because they are functioning both like good reception antennas (noise immunity) and like good transmitting antennas (emission of interference). Exceptional cases are flexible cable tracks over short distances of a maximum of 5 m.

**Shielding** Connect the cable shield immediately at the devices in the shortest and most direct possible way and over the largest possible surface area.

Connect the shield of **analog signal lines** at one end over a large surface area, normally in the control cabinet at the analog device. Make sure the connection to ground/housing is short and over a large surface area.

Connect the shield of **digital signal lines** at both ends over a large surface area and in short form. In the case of potential differences between beginning and end of the line, run an additional bonding conductor in parallel. The guide value for the cross section is  $10 \text{ mm}^2$ .

You absolutely have to equip separable connections with connectors with grounded metal housing.

## Arranging the Components in the Control Cabinet

In the case of non-shielded lines belonging to the same circuit, twist feeder and return cable.

### 11.2.7 General Measures of Radio Interference Suppression for Relays, Contactors, Switches, Chokes, Inductive Loads

If, in conjunction with electronic devices and components, inductive loads, such as chokes, contactors, relays are switched by contacts or semiconductors, appropriate interference suppression has to be provided for them:

- by arranging free-wheeling diodes in the case of d.c. operation
- in the case of a.c. operation, by arranging usual RC interference suppression elements depending on the contactor type, immediately at the inductance

Only the interference suppression element arranged immediately at the inductance does serve this purpose. Otherwise, the emitted noise level is too high which can affect the function of the electronic system and of the drive.

If possible, mechanical switches and contacts should only be realized as snap contacts. Contact pressure and contact material must be suited for the corresponding switching currents.

Slow-action contacts should be replaced by snap switches or by solid-state switches, because slow-action contacts strongly bounce and are in an undefined switching status for a long time which emits electromagnetic waves in the case of inductive loads. These waves are an especially critical aspect in the case of manometric or temperature switches.



## 12 Control Cabinet Cooling

### 12.1 General Information

All devices operated in the control cabinet generate heat due to their power dissipation. The power dissipation increases the temperature inside the control cabinet compared to the ambient temperature of the control cabinet. The temperature inside the control cabinet is decisive as the ambient temperature of the devices.

You may only operate the devices within the allowed ambient temperature range  $T_{a\_work}$  (with derating within  $T_{a\_work\_red}$ ). The control cabinet must therefore be cooled. It is possible to cool the control cabinet in a passive or active way.

The table below contains an orientation guide showing the criteria on which the type of cooling depends.



The following table does not replace your detailed calculation of the heat levels. The data required for this calculation are explained in the following paragraphs.

Check your calculation of the heat levels by measuring the temperature in the control cabinet at the air intake of the components (area A in figure 11-3 [Air intake and air outlet at drive controller on page 148](#)) under full load operation.

Criterion	Small temperature difference $T_{a\_work} - T_a$	Big temperature difference $T_{a\_work\_red} - T_a$	Low degree of power dissipation	High degree of power dissipation (e.g. with HMVxx.xE, HLBxx.x)
low degree of power dissipation (e.g. with derating)	A, B	A	-	-
high degree of power dissipation (e.g. with HMVxx.xE, HLBxx.x)	C	B, C	-	-
small control cabinet surface	B, C	B	B	C
big control cabinet surface	B, C	A	A	C

A cooling via surface of control cabinet  
 B forced ventilation of control cabinet  
 C cooling unit

Fig. 12-1: Orientation guide for the appropriate cooling type

Control Cabinet Cooling

## 12.2 Passive Control Cabinet Cooling

### 12.2.1 Cooling via the Surface of the Control Cabinet

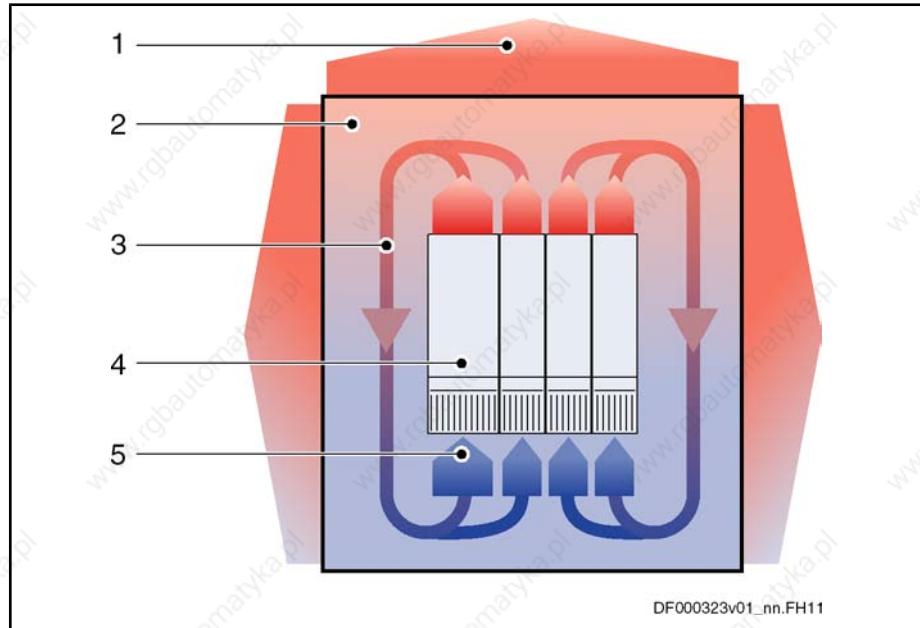

- 1 heat dissipation via surface of control cabinet
- 2 interior of control cabinet
- 3 convection flow of air in control cabinet
- 4 device in control cabinet
- 5 air intake at device

Fig. 12-2: Control cabinet airtight to the outside

Advantage: Control cabinet airtight to the outside without blower and filter.

The surface of the airtight control cabinet required for discharging the power dissipation is to be calculated below.

- Input Data**
- $\Sigma P_{Diss}$ : power dissipation of all devices installed in the control cabinet
  - $T_a$ : maximum temperature outside of the control cabinet
  - $T_{a\_work}$ : maximum allowed ambient temperature of the devices
  - $k$ : heat transition coefficient resulting from material and surface condition of the control cabinet



Avoid additional heating of the control cabinet, e.g. by directly attached constructions and solar radiation.

Allow the cooling air to freely circulate in the control cabinet. For devices with cooling type "n", use additional blowers, if necessary, to force the circulation.

**Required Surface**

$$A_{w_{irk}} \geq \frac{\Sigma P_{Diss}}{k \times (T_{a\_work} - T_a)}$$

Fig. 12-3: Required surface

**Exemplary Calculation**

**Power sections**

2 × HCS02.1E-W0012 with

## Control Cabinet Cooling

- $P_{\text{Diss\_cont}} = 80 \text{ W}$  (at  $I_{\text{out\_cont}}$ )
- $P_{\text{BD}} = 50 \text{ W}$
- $P_{\text{N3}} = 12 \text{ W}$

**Control sections**

2 × CSB01.1N-FC with  $P_{\text{N3}} = 8.5 \text{ W}$

**General conditions**

- material of control cabinet: lacquered steel plate
- maximum temperature outside of the control cabinet: 30 °C

**Result**

$$\Sigma P_{\text{Diss}} = 2 \times (80 + 50 + 12) + 2 \times 8.5 = 301 \text{ W}$$

$$T_{\text{a}} = 30 \text{ °C}$$

$$T_{\text{a\_work}} = 40 \text{ °C}$$

$k \sim 5.5 \text{ W/(m}^2\text{K)}$  (lacquered steel plate)

Required effective surface:

$$A_{\text{wirk}} \geq \frac{301}{5,5 \times (40 - 30)} = 5,472 \approx 5,5 \text{ m}^2$$

Control Cabinet Cooling

## 12.3 Active Control Cabinet Cooling

### 12.3.1 Ventilation of the Control Cabinet

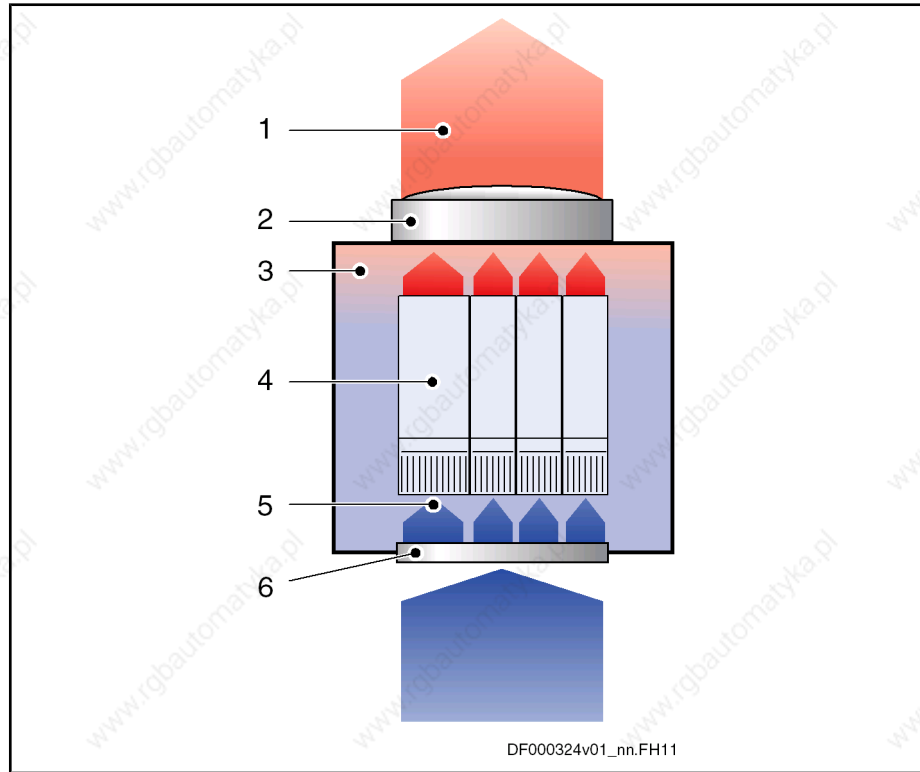

DF000324v01\_nn.FH11

- 1 heat dissipation via control cabinet blower
- 2 control cabinet blower
- 3 interior of control cabinet
- 4 device in control cabinet
- 5 air intake at device
- 6 air intake at control cabinet

Fig. 12-4: Ventilation of the control cabinet

Advantage: compact control cabinet

The cooling air current required for discharging the power dissipation from the control cabinet is to be calculated below. This will allow selecting the appropriate control cabinet blower.

- Input Data**
- $\Sigma P_{Diss}$ : power dissipation of all devices installed in the control cabinet
  - $T_a$ : maximum temperature outside of the control cabinet
  - $T_{a\_work}$ : maximum allowed ambient temperature of the devices
  - $f_{air}$ : air constant at 1000 m installation altitude (operation under rated conditions without derating of the devices)

**Required Cooling Air Current**

$$\dot{V}_{min} = \frac{\Sigma P_{Diss}}{T_{a\_work} - T_a} \times f_{air}$$

Fig. 12-5: Required cooling air current

**Exemplary Calculation Power sections**

2 × HCS02.1E-W0012 with



- $P_{\text{Diss\_cont}} = 80 \text{ W}$  (at  $I_{\text{out\_cont}}$ )
- $P_{\text{BD}} = 50 \text{ W}$
- $P_{\text{N3}} = 12 \text{ W}$

**Control sections**

2 × CSB01.1N-FC with  $P_{\text{N3}} = 8.5 \text{ W}$

**General conditions**

maximum temperature outside of the control cabinet: 30 °C

**Result**

$$\Sigma P_{\text{Diss}} = 2 \times (80 + 50 + 12) + 2 \times 8.5 = 301 \text{ W}$$

$$T_{\text{a}} = 30 \text{ °C}$$

$$T_{\text{a\_work}} = 40 \text{ °C}$$

$$f_{\text{air}} \sim 3.5 \text{ m}^3 \text{ K/Wh (1000 m)}$$

Required cooling air current:

$$\dot{V}_{\text{min}} \geq \frac{301}{40 - 30} \times 3,5 = 105,35 \approx 106 \frac{\text{m}^3}{\text{h}}$$



The integrated blowers of the devices have been dimensioned with regard to the pressure conditions of their cooling systems and are not provided for control cabinet cooling.

Select a control cabinet blower which at least conveys the calculated cooling air current. Take into account that installed filters, for example, reduce the output of the control cabinet blower.

## 12.4 Arrangement of Cooling Units

Unless the nominal data are reduced, the drive controller may only be operated up to a specified maximum ambient temperature. Therefore, a cooling unit might possibly be required.

**CAUTION**

### Possible damage to the drive controller! Operational safety of the machine endangered!

Take the information below into account.

#### Avoiding Dripping or Spraying Water

Due to their operating principle, condensation water is formed when cooling units are used.

For this reason, observe the following aspects:

- Always position cooling units in such a way that condensation water cannot drip onto the devices in the control cabinet.
- Position the cooling unit in such a way that the blower of the cooling unit does not spray accumulated condensation water onto the devices in the control cabinet. Mount the air duct in the control cabinet accordingly.

Control Cabinet Cooling

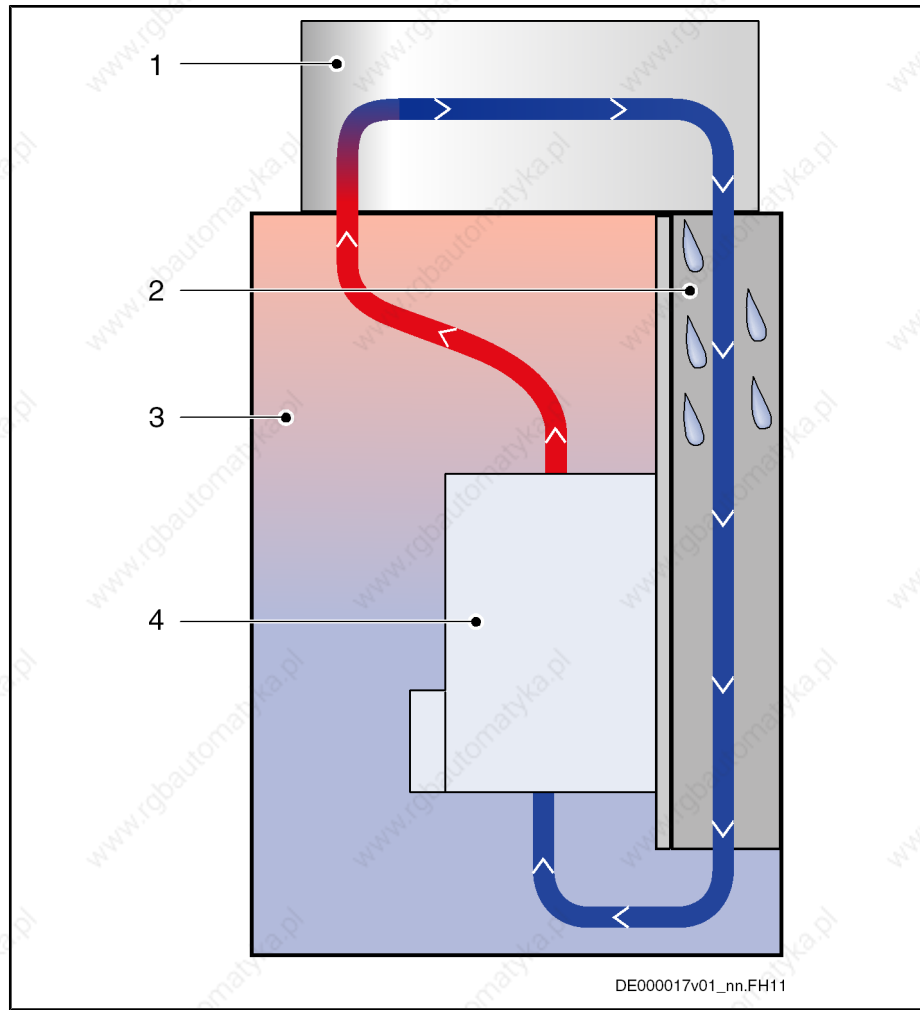

- 1 cooling unit
- 2 air duct (protects devices against condensation water)
- 3 interior of control cabinet
- 4 device in control cabinet

Fig.12-6: Cooling unit on top of the control cabinet

## Control Cabinet Cooling

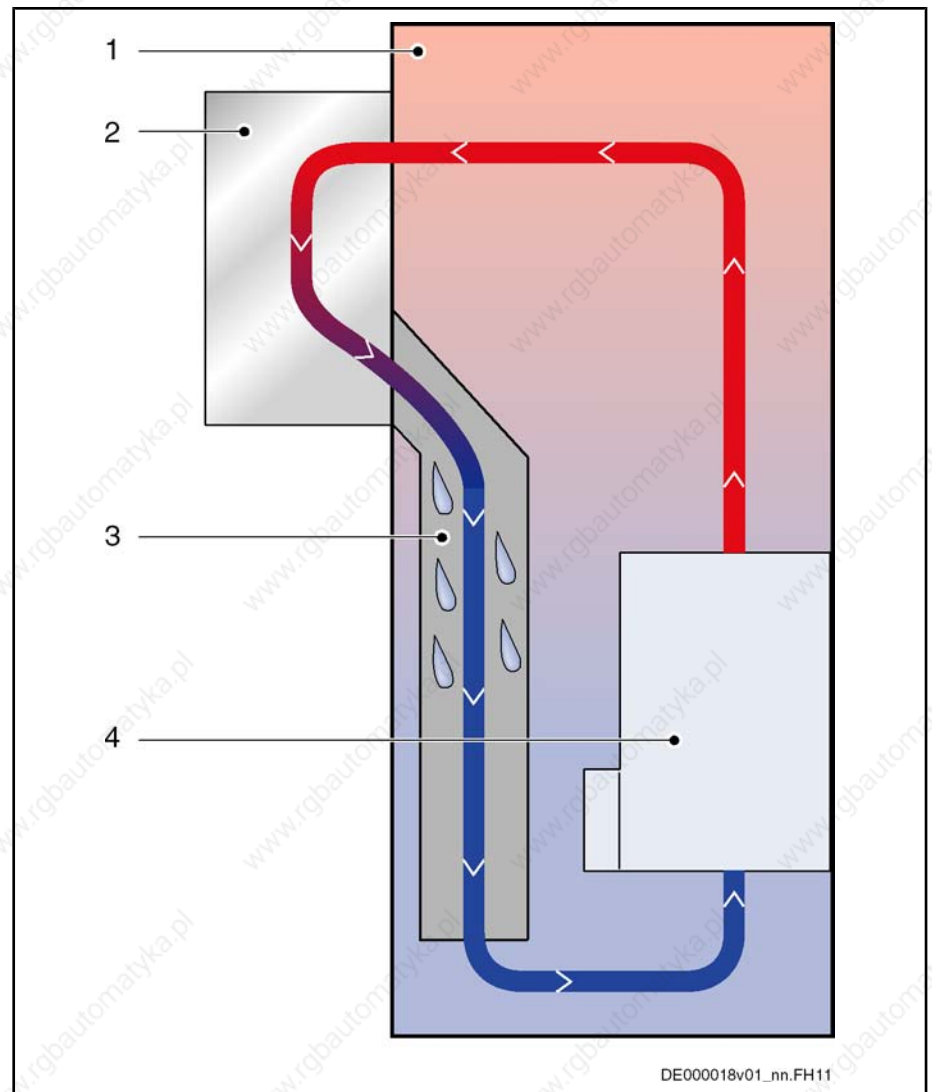

- 1 interior of control cabinet
- 2 cooling unit
- 3 air duct (protects devices against condensation water)
- 4 device in control cabinet

Fig. 12-7: Cooling unit at the front of the control cabinet

### Avoiding Moisture Condensation

Moisture condensation occurs when the temperature of the device is lower than the ambient temperature.

- Set cooling units with temperature adjustment to the maximum surrounding temperature and not lower!
- Set cooling units with follow-up temperature in such a way that the interior temperature of the control cabinet is no lower than the temperature of the surrounding air. Set the temperature limitation to the maximum surrounding temperature!
- Only use well-sealed control cabinets so that moisture condensation cannot arise as a result of warm and moist external air entering the cabinet.
- In the event that control cabinets are operated with the doors open (commissioning, servicing etc.), it is essential to ensure that after the doors are closed the drive controllers cannot at any time be cooler than the air in the control cabinet. For this reason, sufficient circulation must be provided inside the control cabinet to avoid pockets of heat.

## 12.5 Multiple-Line Design of the Control Cabinet



### Air guides, blowers, arrangement

Particular attention should be paid to the maximum allowed air intake temperature of devices when they are arranged in multiple lines in the control cabinet.

If possible, place devices with a high degree of power dissipation (e.g. supply units with braking resistors, DC bus resistor units)

- in the top line and
- near the outlet air aperture to the cooling unit.

To protect the devices in the upper lines against the warm air of the air outlet of the devices beneath, mount **air guides** between the lines.

**Additional blowers** are used to convey the warm air to the cooling unit and to supply cooling air to the upper lines.

At the installed control cabinet, check the temperature at the air intake of all devices.



To extend the module bus connection, the accessory RKB0001 is available. Observe the assignment.

Control Cabinet Cooling

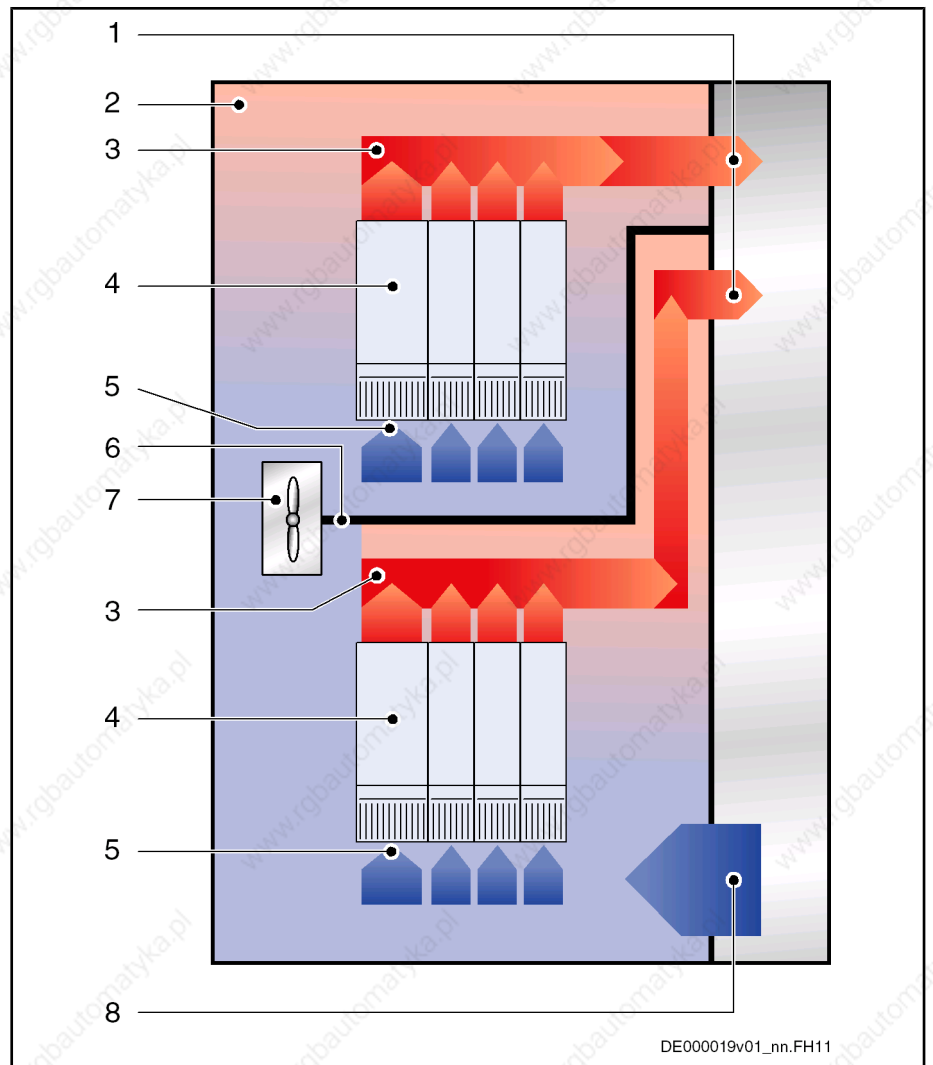

- 1 discharge of heated air to cooling unit
- 2 interior of control cabinet
- 3 conveying direction of heated air in area where air flows off
- 4 device in control cabinet
- 5 air intake at device
- 6 air guide in control cabinet
- 7 blower in control cabinet
- 8 supply of cooled air from cooling unit

Fig. 12-8: Example of arrangement for double-line design



## 13 Connections of the Components in the Drive System

### 13.1 System Connections of the Components

#### 13.1.1 General Information

Electrical connections for operating the drive system Rexroth IndraDrive:

- |                                  |   |
|----------------------------------|---|
| <b>In the System Environment</b> | <ul style="list-style-type: none"> <li>• connection X3 or PE to equipment grounding system</li> <li>• connection X3 to supply with power voltage</li> <li>• connection X13 or terminal block 0V / +24V to supply with control voltage</li> <li>• connection to control unit and/or master communication</li> </ul>  |
| <b>Within the Drive System</b>   | <ul style="list-style-type: none"> <li>• equipment grounding conductor connections PE to X3 or joint bars at the devices</li> <li>• DC bus connections L+ with bars</li> <li>• DC bus connections L- with bars</li> <li>• control voltage connections 0V with bars</li> <li>• control voltage connections +24V with bars</li> <li>• module bus connections X1 with ribbon cable</li> <li>• motor power connections via motor power cable at X5</li> <li>• connections for motor temperature monitoring and motor holding brake via motor power cable at X6</li> </ul> |

#### 13.1.2 Position of System Connections

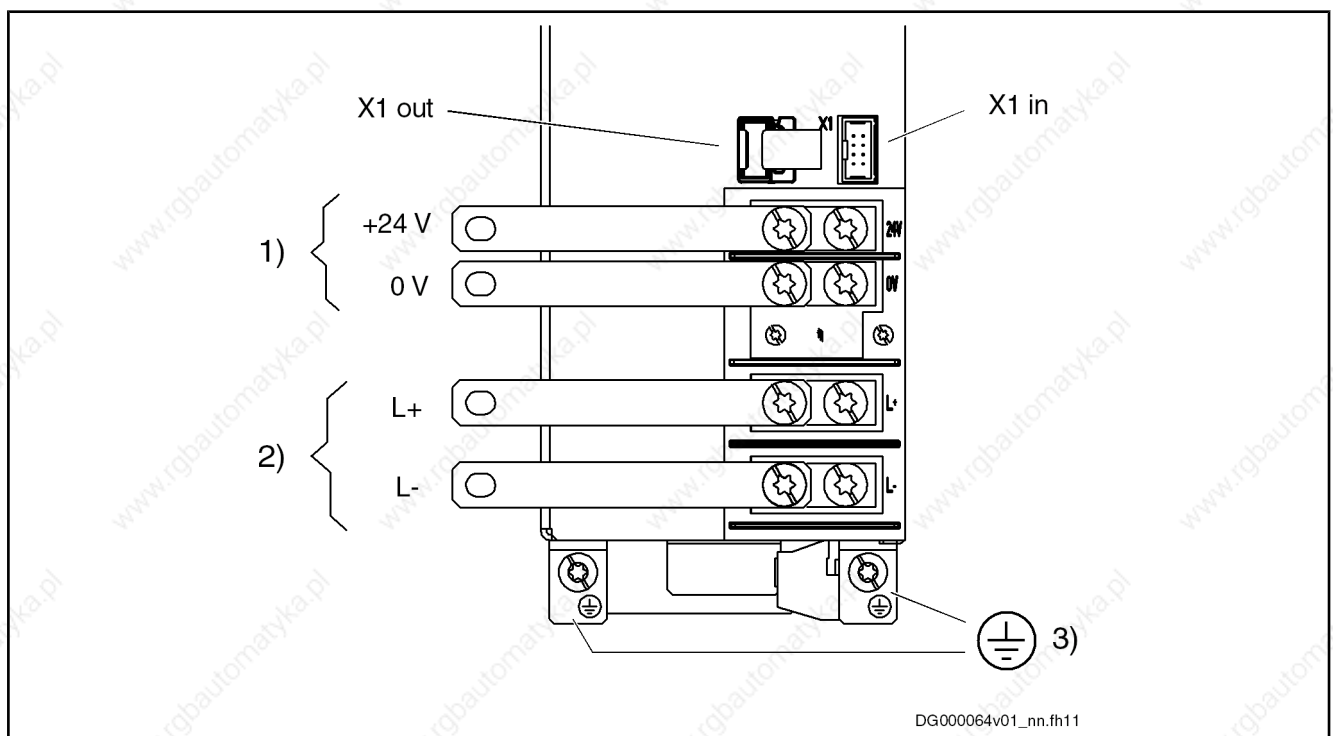

- |               |                               |
|---------------|-------------------------------|
| 1)            | control voltage               |
| 2)            | DC bus                        |
| 3)            | equipment grounding conductor |
| X1 out, X1 in | module bus                    |
- Fig. 13-1: Connections at power section



## Connections of the Components in the Drive System

### 13.1.3 Ground Connection of Housing

The ground connection of the housing is used to provide functional safety of the drive controllers and protection against contact in conjunction with the equipment grounding conductor.

**Avoid spark discharge of static charges!**

In some applications (e.g. printing or packaging), high static charges can develop. Make sure that these charges can be directly discharged against ground at their point of origin. If necessary, install additional lines between the fixing points of the motor flanges (charge acceptance) and the ground connection of the drive system (e.g. mounting surface of the drive controllers in the control cabinet).

Ground the housings of the devices:

1. Connect the bare metal back panel of the device in conductive form to the mounting surface in the control cabinet. To do this, use the supplied mounting screws.
2. Connect the mounting surface of the control cabinet in conductive form to the equipment grounding system.
3. Connect the bare metal back panel of the mains filter in conductive form to the mounting surface in the control cabinet. Connect the mounting surface of the mains filter with the lowest possible impedance (over a large surface area) to the mounting surface of the drive controllers (see item 1).

### 13.1.4 Connection Point of Equipment Grounding Conductor and Equipment Grounding Connections

#### General Information

The connection of the equipment grounding conductors of the devices and their connection to the equipment grounding system are indispensable for the electrical safety of the drive system.

**DANGER****Dangerous contact voltage at device housing! Lethal electric shock!**

Devices of the Rexroth IndraDrive product range are devices with increased leakage current (greater than AC 3.5 mA or DC 10 mA). Therefore, always install a stationary connection of the equipment grounding conductor.

Observe the description below.

In the drive system Rexroth IndraDrive, connect the equipment grounding conductor connections of all devices and additional components to the equipment grounding system.

Connections of the Components in the Drive System

Involved devices	Equipment grounding connections between devices		Connection to equipment grounding system in control cabinet at devices	
<b>HMV01</b> <b>HCS03</b> HMS01 HMD01 HLB01.1D HLC01.1D HLC01.1C	interconnect joint bars at front of devices	HMV01 HCS03 HMS01 HMD01 HLB01.1D HLC01.1D HLC01.1C	<b>realized in central form</b> one connection at	HMV01 HCS03
<b>HCS02 with HAS04</b> HLB01.1C HLC01.1C HMS01 HMD01	interconnect joint bars at front of devices	<b>HAS04</b> HLB01.1C HLC01.1C HMS01 HMS02 HMD01	<b>realized in central form</b> one connection at	HCS02
<b>HCS02 without HAS04</b> HCS02 HMS01 HMS02 HMD01 HLB01.1C HLC01.1C HLB01.1D HLC01.1	interconnect joint bars at front of devices	HMS01 HMS02 HMD01 HLB01.1C HLC01.1C HLB01.1D HLC01.1D	<b>one connection each</b> at all	HCS02
			<b>and</b> one connection at connected drive system, consisting of all	HMS01 HMS02 HMD01 HLB01.1C HLC01.1C HLB01.1D HLC01.1D
<b>HMV02</b> HMS02 HNL02 HNS02	interconnect joint bars at front of devices	HMV02 HMS02	<b>one connection each</b> at all	HNL02 HNS02
			<b>and</b> one connection at connected drive system, consisting of all	HMV02 HMS02

Fig. 13-2: Equipment grounding connections

### Connections of the Components in the Drive System

#### Equipment Grounding Connections Between Devices

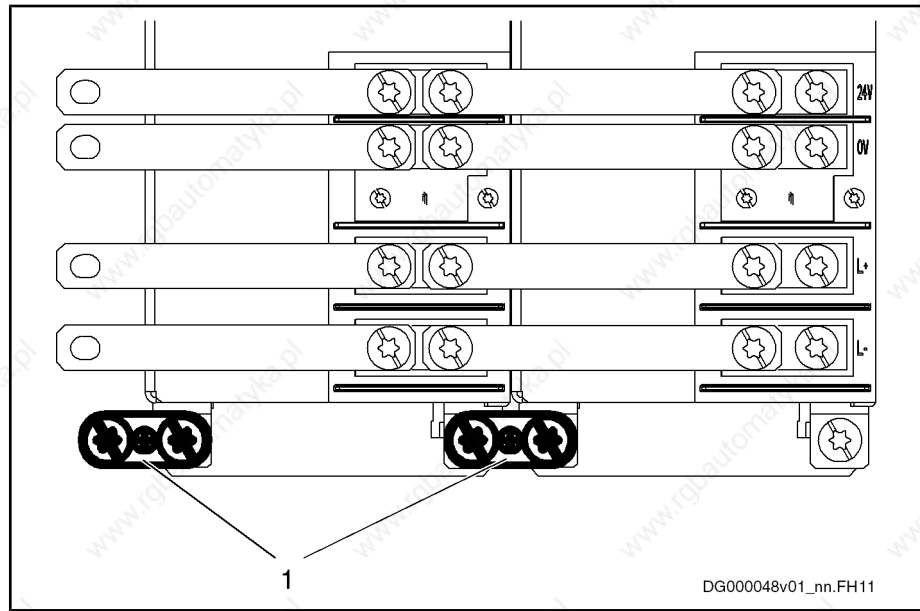

1 joint bar

Fig. 13-3: Equipment grounding connections between devices

#### Connection to Equipment Grounding System in Control Cabinet

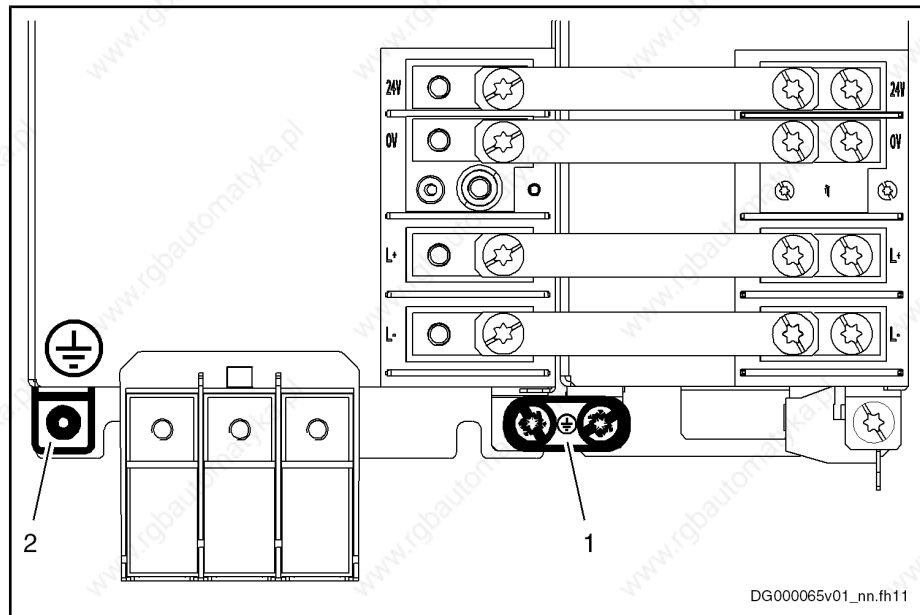

1 joint bar

2 connection point for connection to equipment grounding system in control cabinet

Fig. 13-4: Equipment grounding connections

Connections of the Components in the Drive System

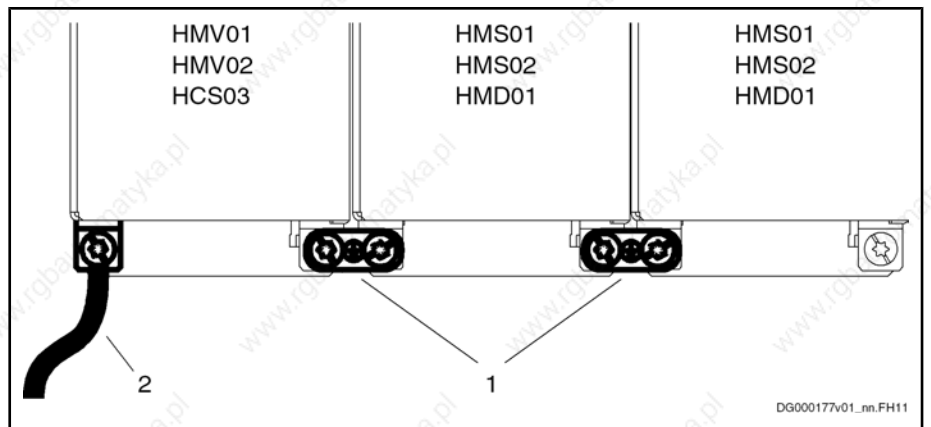

- 1 joint bar
- 2 connection to equipment grounding system

Fig. 13-5: Equipment grounding connection in the case of supply via HMV01, HMV02 or HCS03

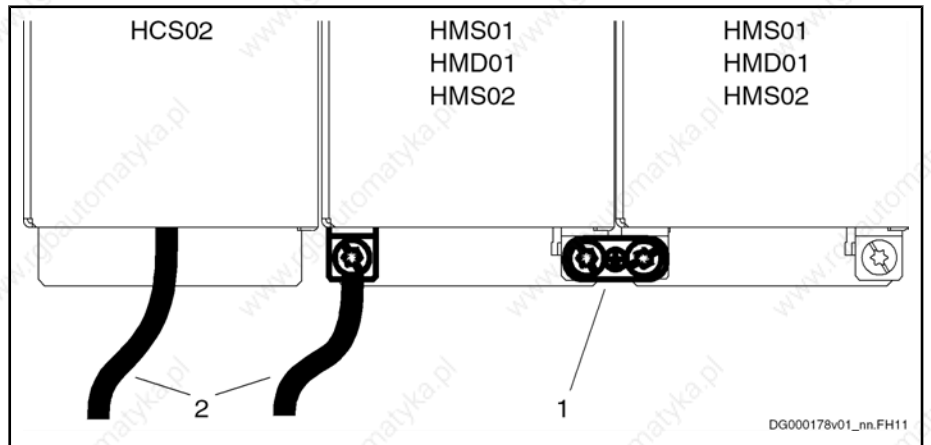

- 1 joint bar
- 2 connection to equipment grounding system

Fig. 13-6: Equipment grounding connection in the case of supply via HCS02

Connections of the Components in the Drive System



**Equipment grounding conductor: material and cross section**

For the equipment grounding conductor, use the same metal (e.g. copper) as for the outer conductors.

For the connections from the equipment grounding conductor connection of the device to the equipment grounding conductor system in the control cabinet, make sure the cross sections of the lines are sufficient.

Cross sections of the equipment grounding connections:

- for **HCS03.1E** drive controllers and **HMV01** supply units, at **least 10 mm<sup>2</sup>**, but not smaller than the cross sections of the outer conductors of the mains supply feeder
- for **HCS02.1E** drive controllers, at **least 4 mm<sup>2</sup>**, but not smaller than the cross sections of the outer conductors of the mains supply feeder

Additionally, mount the housing of HCS02.1E to a bare metal mounting plate. Connect the mounting plate, too, with at least the same cross section to the equipment grounding conductor system in the control cabinet.

For outer conductors with a cross section greater than 16 mm<sup>2</sup>, you can reduce the cross section of the equipment grounding connection according to the table "Cross section of equipment grounding conductor, excerpt from EN 61800-5-1:2003".

Cross-sectional area A of outer conductors	Minimum cross-sectional area A <sub>PE</sub> of equipment grounding connection
$A \leq 16 \text{ mm}^2$	A
$16 \text{ mm}^2 < A \leq 35 \text{ mm}^2$	16
$35 \text{ mm}^2 < A$	A / 2

Fig. 13-7: Cross section of equipment grounding conductor, excerpt from EN 61800-5-1:2003, table 2

### 13.1.5 Connection to Mains Choke and Mains Filter

Order of the connections to the supply mains:

supply mains → mains filter → mains choke → supply unit or drive controller



**Only operate allowed loads at the mains filter of the drive system!**

At the three-phase filter for the power connection of regenerative supply units, it is only allowed to operate the following loads:

- HMV supply unit with mains choke and, if necessary, mains contactor

Do not operate any motor blowers, power supply units etc. at the mains filter of the drive system.

The cables to the mains choke and mains filter carry a high potential of interference; you should therefore keep them as short as possible and twist them.



The cables allowed at HMV supply units between mains choke and the HMV mains input must be **of a maximum length of 5 m and twisted** (or run in a grounded, metallic cable duct).

Connections of the Components in the Drive System

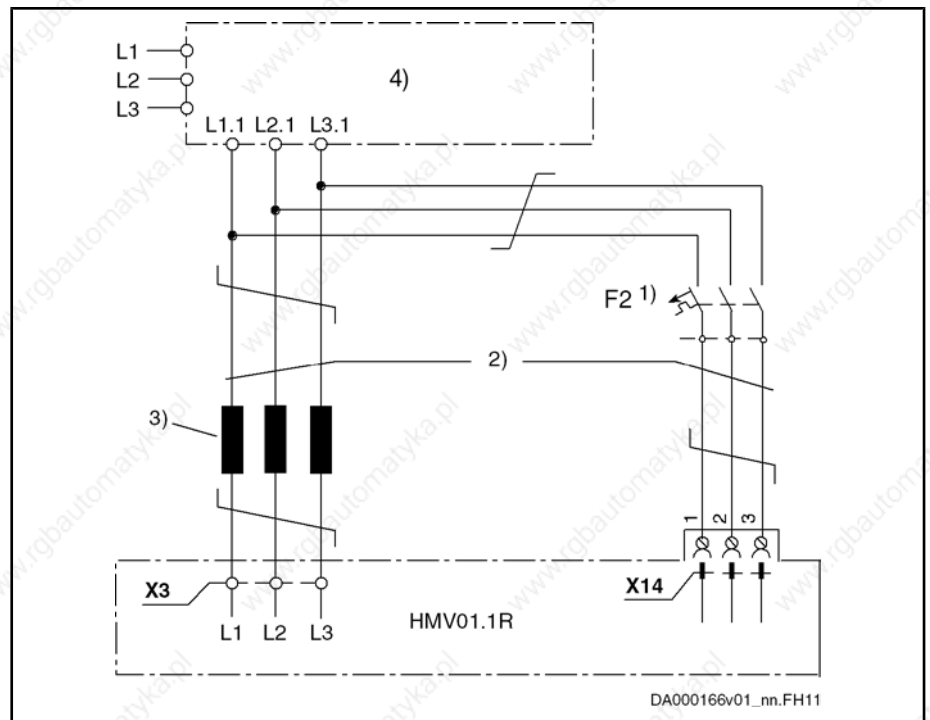

- 1) fusing of connection X14
- 2) in-phase connection required
- 3) mains choke
- 4) mains filter

Fig. 13-8: Synchronizing voltage HMV01.1R

See also EMC measures for design and installation in chapter 11.2.3 EMC Measures for Design and Installation, page 159.

### 13.1.6 Connection of the DC Bus Connections

#### General Information



**CAUTION**

**Property damage in case of error caused by too small line cross section!**

Observe the **current carrying capacity of the connection lines** at the DC bus connections of the components used; see chapter "DC Bus Connection (L+, L-)" in the Project Planning Manual "Rexroth IndraDrive Supply Units and Power Sections".

Install connection lines at the DC bus connections in such a way that they are protected by the line protection at the mains connection of the supply unit or by additional fuses before the connection line.

View	Technical Data	Identification	Function
		L+	connections to connect the DC bus connections
		L-	

DA000176v01\_nn.FH11

Connections of the Components in the Drive System

Screw connection	Unit	Min.	Max.
M6 thread at device (terminal block)			
tightening torque	Nm	5,5	6,5
short circuit protection		via fusing elements connected in the incoming circuit to the mains connection	
overload protection		via fusing elements connected in the incoming circuit to the mains connection	
<b>current carrying capacity "looping through" from L+ to L+, L- to L-</b> (contact bars in scope of supply of accessory HAS01)			
with contact bars -072	A		220
<b>additionally</b> with contact bars -042 and end piece	A		245

Fig.13-9: Function, pin assignment, properties

Single-Line Arrangement

The figure below illustrates the connection point and connection of the DC bus connections in the case of single-line arrangement **with contact bars** for the system components

- HMV01
- HMS01
- HMD01
- HLB01.1D
- HCS03

Design

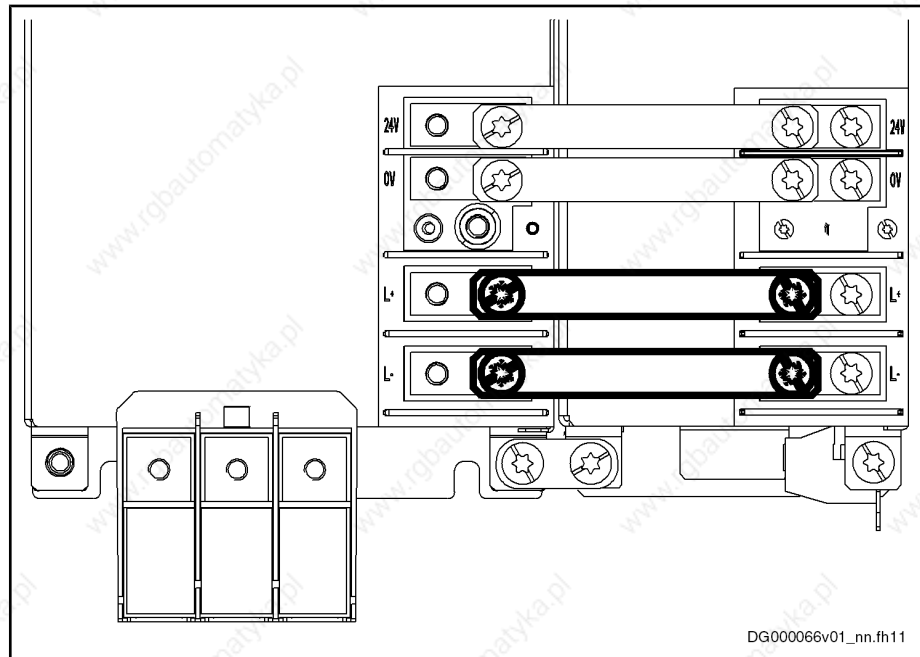

Fig.13-10: Contact bars

Multiple-Line Arrangement

For multiple-line arrangement of drive controllers, the connection for DC bus and control voltage supply is realized **with twisted cables**.



**CAUTION****Damage to the drive controller!**

- The DC bus connections of stacked drive controllers must be correctly interconnected.
- Connect L+ connections only to other L+ connections and L- connections only to other L- connections.
- Observe the measures regarding maximum allowed line lengths and minimum required line cross sections.

**Maximum Allowed Line Length at DC Bus Connection**

The line length at the DC bus connection is limited to protect the devices. For the maximum allowed line lengths between the electrical connections, see table below.



In this context, observe the data in chapter "Minimum Requirements to the Connection Lines"!

Allowed line length / m								
from	to							
	HMV01	HMV02	HCS03	HCS02	HMS01 / HMD01	HMS02	HLB01	HLC01
HMV01	0,5	--	--	--	2 <sup>1)</sup>	--	0,35	0,35
HMV02	--	0,5	--	--	--	0,35	0,35	0,35
HCS03	--	--	0,5	--	2 <sup>1)</sup>	--	--	0,35
HCS02	--	--	--	0,5	2 <sup>1)</sup>	0,35	0,35	0,35
HMS01 / HMD01	--	--	--	--	2 <sup>1)</sup>	--	0,35	0,35
HMS02	--	--	--	--	--	2 <sup>1)</sup>	0,35	0,35
HLB01	--	--	--	--	--	--	0,35	0,35
HLC01	--	--	--	--	--	--	--	0,35

<sup>1)</sup> additional lateral distance requires the module bus connection RKB0001  
 Fig. 13-11: Maximum allowed line lengths at DC bus

**Line length > 2 m between supply unit and drive controller**

For arrangements of supply units which supply, for example, drive controllers over line lengths > 2 m, take special measures:

- Use HLC01 DC bus capacitor units at every drive system.
- Dimension the minimum size of HLC01 according to the projected continuous power of the respective drive system: 47 µF per kilowatt [kW] of continuous power.

Example: 50 kW calculated continuous power in DC bus requires 2350 µF at this system, thus at least 1 HLC01.1D-02M4.

## Connections of the Components in the Drive System

**Maximum length between drive systems and drive controllers**

Multiple-line arrangement or distance between the devices requires the accessory **RKB0001** for the **module bus connection** between the devices (see chapter [14 Accessories in the Drive System Rexroth IndraDrive, page 201](#)).

The maximum length of the accessory RKB0001 limits the length of the DC bus connection to be achieved between drive systems.

**Minimum Requirements to the Connection Lines**

**Dielectric Strength** The connection lines from the supply unit to the drive systems and between the drive systems must have a dielectric strength of at least:

- 1000 V against each other
- 700 V against ground

**Line Cross Section** Determine the minimum line cross section from supply unit to drive systems and between drive systems by means of the **rated current**. For rated current, use the higher value from the following calculations:

- calculate the mains-side phase current
- calculate the current in the branch with the greatest DC bus power

**Minimum cross section UL**

Use in the scope of UL requires the line cross section  $A \geq 35 \text{ mm}^2$  (AWG2).



For connecting line cross sections of **35 mm<sup>2</sup>** (AWG2) and **50 mm<sup>2</sup>** (AWG1/0), use the accessory **HAS05.1-004**.

**Routing** Routing of the connection lines from the supply unit to drive systems and between the drive systems:

- **twist** the lines with the minimum possible length of lay, but 120 mm as a maximum
- with minimum mechanical distance to ground potential
- with a minimum distance of 200 mm to control voltage lines

The figures below illustrate the correct DC bus connection for stacked drive controllers. The illustrated way of connection keeps bare wire sections from being situated directly vis-à-vis. This avoids voltage arcing.

**Cable Routing to the Left****CAUTION****Damage caused by voltage arcing!**

Insulate ring terminals and connecting lines with a heat-shrinkable sleeve. Afterwards only strip the insulation of the contact surface of the ring terminal. Realize connections according to figure.

Connections of the Components in the Drive System

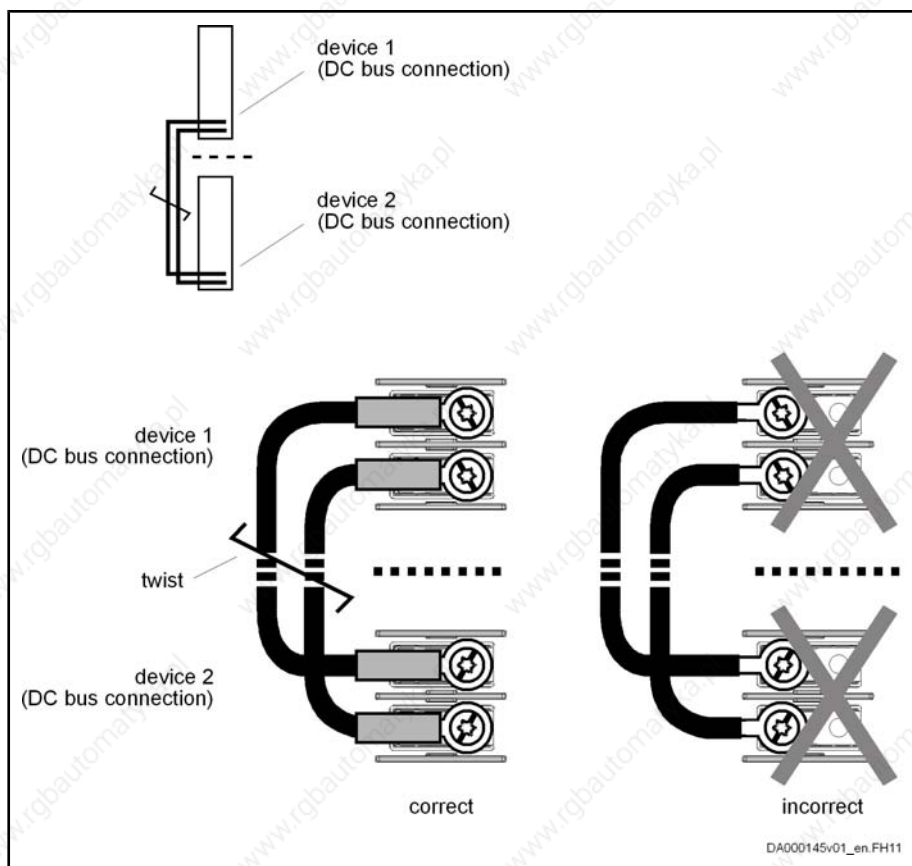

Fig.13-12: DC bus connections for cable routing to the left

Cable Routing to the Right



CAUTION

Damage caused by voltage arcing!

Insulate ring terminals and connecting lines with a heat-shrinkable sleeve. Afterwards only strip the insulation of the contact surface of the ring terminal.

Connections of the Components in the Drive System

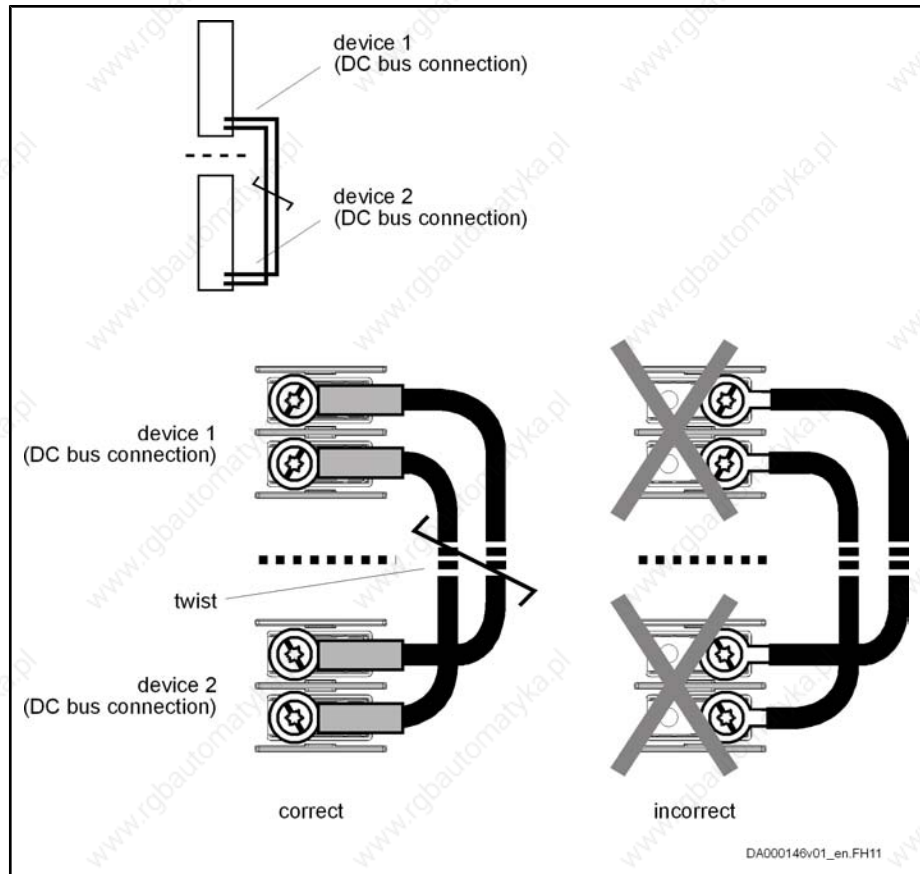

Fig. 13-13: DC bus connections for cable routing to the right

### 13.1.7 Connection of the Control Voltage Connections

#### General Information



**CAUTION**

**Property damage in case of error caused by too small line cross section!**

Make use of the contact bars provided to loop-through.

Observe the current carrying capacity of the connections for 24V supply at the devices used; see section "Terminal Block, 24 V - 0V (24V Supply)" and "X13, Control Voltage (24V, 0V)" in the Project Planning Manual "Rexroth IndraDrive Supply Units and Power Sections".



Connect the connections X13 of components with connector for 24V supply individually and in star-shaped form to the 24V supply in the control cabinet.

Connection of 24V Supply per Terminal Block	Identification	Function
	+24V	power supply connection to neighboring devices with contact bars from the HAS01.1 accessory
	0V	reference potential for power supply connection to neighboring devices with contact bars from the HAS01.1 accessory

DA000175v01\_nn.FH11

Connections of the Components in the Drive System

Screw connection	Unit	Min.	Max.
M6 thread at device (terminal block)			
tightening torque	Nm	5,5	6,5
power consumption	W	see P <sub>N3</sub> (see index entry with reference to the corresponding page)	
voltage load capacity	V	see U <sub>N3</sub> (see index entry with reference to the corresponding page)	
polarity reversal protection		within the allowed voltage range by internal protective diode	
<b>current carrying capacity "looping through" from 24V to 24V, 0V to 0V</b> (contact bars in scope of supply of accessory HAS01)			
with contact bars -072-	A	220	

Fig. 13-14: Function, pin assignment, properties

**Single-Line Arrangement**

The figure below illustrates the connection point and connection of the control voltage connections for devices **HMV01, HMV02, HMS01, HMS02, HMD01, HLB01.1D and HCS03** in single-line arrangement.

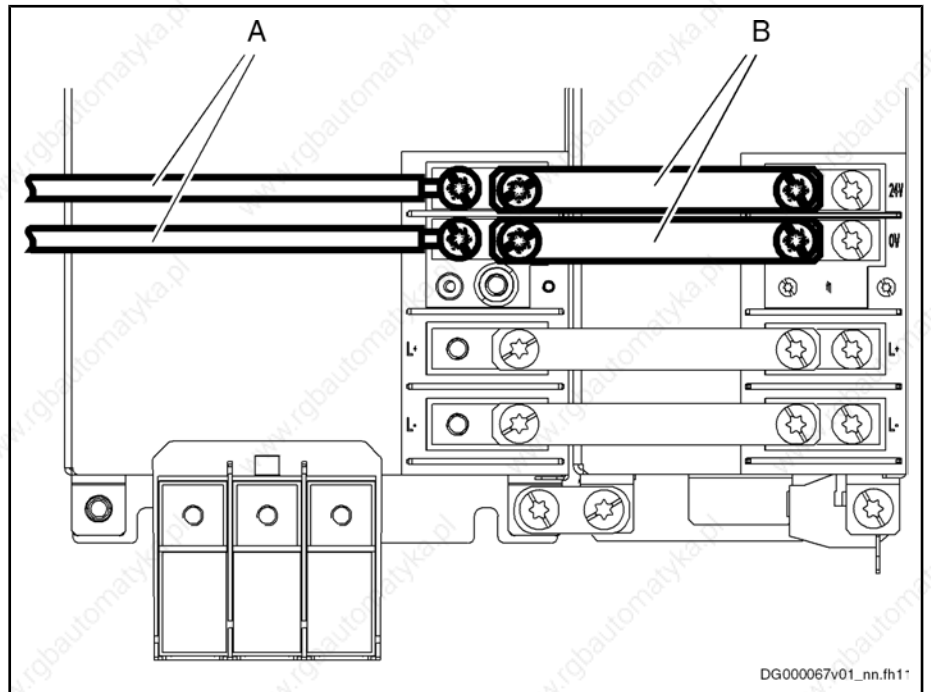

- A cable (to source of control voltage supply)
- B contact bars

Fig. 13-15: Connection points and connections of control voltage

**Multiple-Line Arrangement**

The following figures show the correct control voltage connection for stacked drive controllers. The illustrated way of connection ensures that the touch guard can be correctly mounted and the required clearances and creepage distances can be complied with.

The cables have to be twisted.

### Connections of the Components in the Drive System

#### Cable Routing to the Left

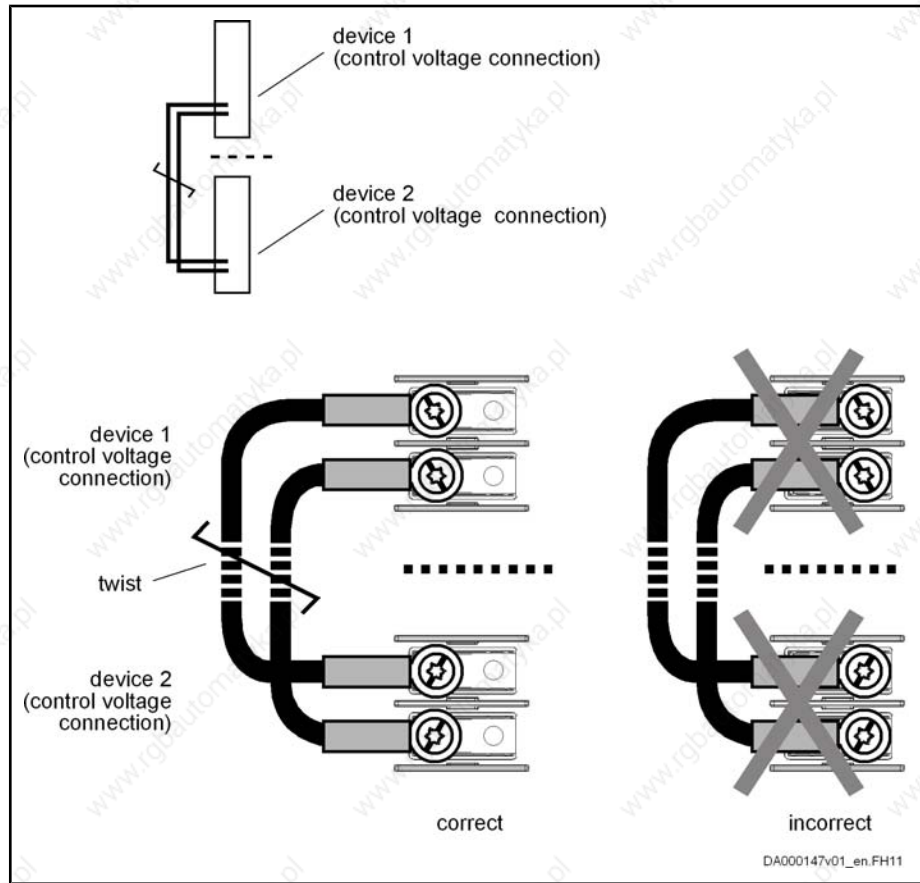

Fig.13-16: Control voltage connections for cable routing to the left



Connections of the Components in the Drive System

Cable Routing to the Right

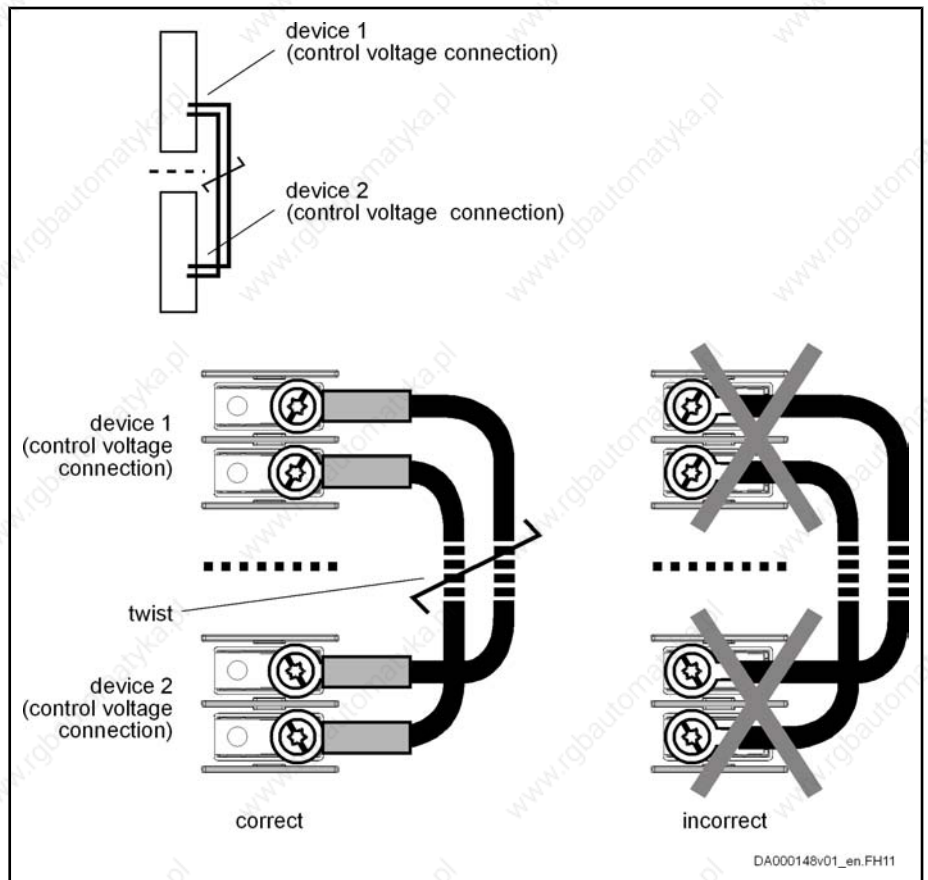

Fig. 13-17: Control voltage connections for cable routing to the right

13.1.8 Module Bus Connection X1

The module bus connection is used for signal exchange within the drive system and takes place via the supplied ribbon cables.

Graphic Representation

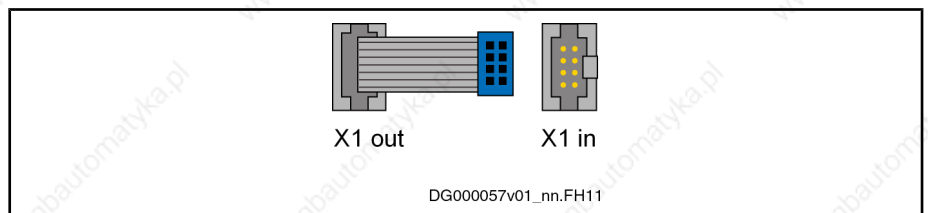

Fig. 13-18: X1



When extension cables are used for the module bus, they must be **shielded**. Their total length mustn't exceed a **maximum of 40 m**.

To extend the module bus connection, the accessory **RKB0001** is available.

13.1.9 Connection of Motor to Drive Controller X5, X6

General Information

The connection to the motor takes place with Rexroth power cables. The motor power cables contain:



Connections of the Components in the Drive System

*Connection X5 (power)*

- outputs to motor A1, A2, A3
- equipment grounding conductor connection
- overall shield

*Connection X6 (control contacts)*

- motor temperature monitoring with partial shield
- motor holding brake with partial shield

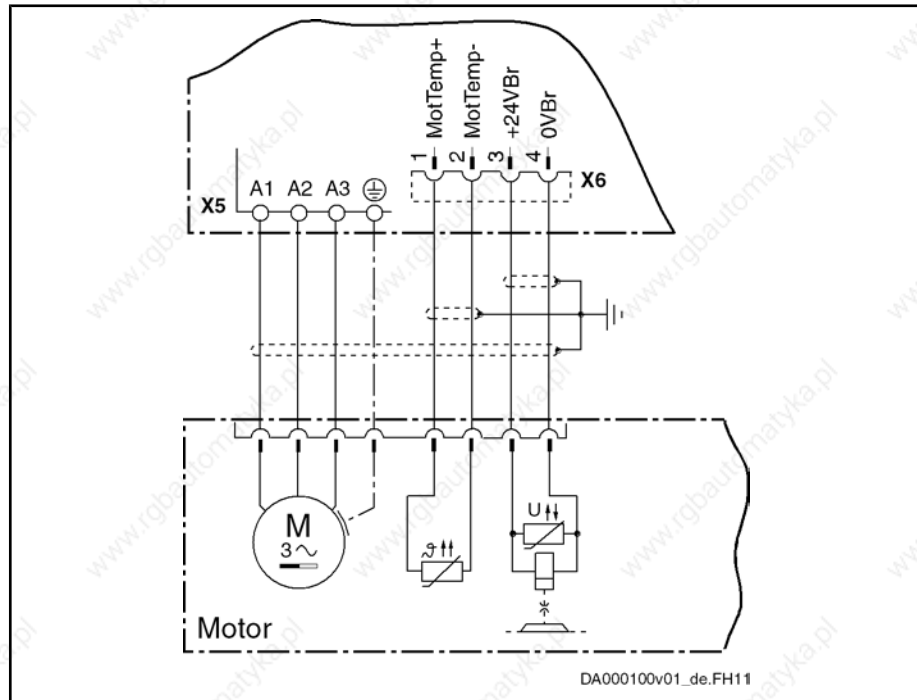

Fig. 13-19: Motor connection



For detailed information, particularly on suitable additional parts, such as control cabinet ducts and extensions, see documentation "Rexroth Connection Cables".

Minimum requirements for connecting the motor power cables to the drive controller:

- Connect the shield of the motor power cable **over the largest possible surface area (with low impedance)** to the drive controller. The connection of cable shields by means of round wires (so-called "pig tails") at the cable ends to ground and housing is normally insufficient.
- Make sure there is sufficient **strain relief** for the motor power cable itself.
- For further notes on how to route the cables, see section "Arranging the Components in the Control Cabinet" under "EMC Measures" and "EMC-Optimal Installation".

According to the individual connection properties, these requirements can be fulfilled with or without the HAS02 accessory.

**Shield Connection with Accessory HAS02**

Using the optional accessory HAS02 with connection over a large surface area directly to the device is the best solution for shield connection. The figure below illustrates this **by the example of HCS02 drive controllers**:

## Connections of the Components in the Drive System



Fig. 13-20: Connecting HAS02 to HCS02



For information on the available accessory HAS02 and how to mount it, see chapter "Accessories in the Drive System Rexroth IndraDrive" under "Shield Connection HAS02" and "Mounting the HAS02 Accessories"

### Shield Connection Without Accessory HAS02

For shield connection without HAS02 accessory, connect the cable shield with the lowest possible impedance to the drive controller.

The following paragraphs describe two basic alternatives of this kind of connection.

#### Alternative 1

Connect cable shield to a ground bus. The maximum distance between ground bus and device connection is 100 mm. For this purpose take the given length of the single strands at the cable end into account for ready-made Rexroth motor power cables.

Connections of the Components in the Drive System

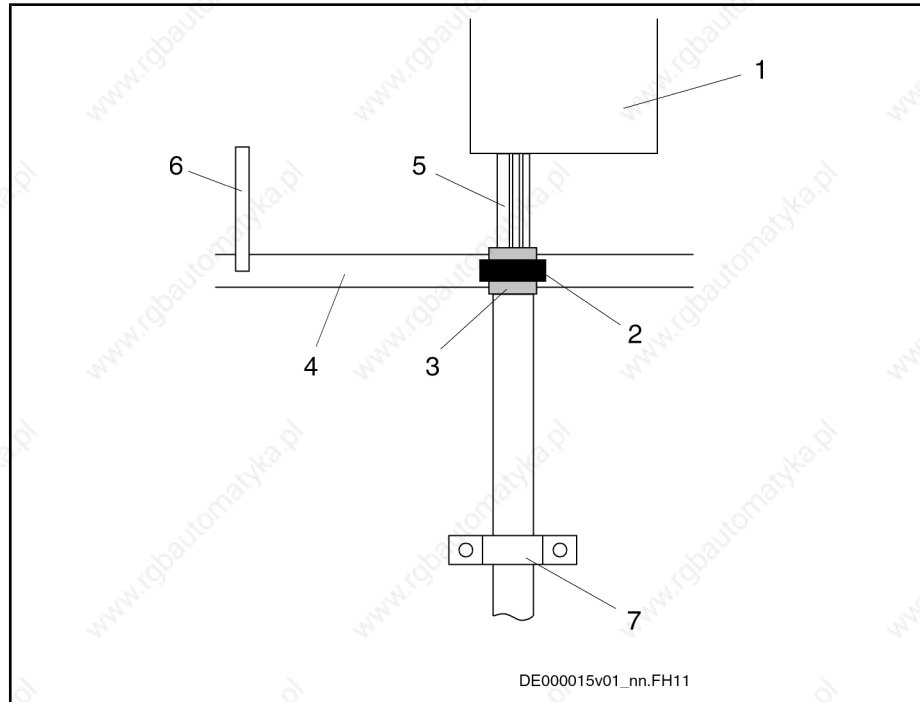

- 1: drive controller
- 2: clip for shield connection
- 3: overall shield of the motor power cable folded back
- 4: ground bus in control cabinet
- 5: single strands of motor power cable
- 6: connection of ground bus to supplying device
- 7: strain relief (as near as possible to exit point from control cabinet)

Fig. 13-21: Shield connection, alternative 1

- With a clip (2) connect overall shield of motor power cable (3) to ground bus (4). (If you use your own cable, make sure the shields of the two inner pairs of wires are in contact with the overall shield.)
- With a cable (6) (line cross section at least 10 mm<sup>2</sup>), connect ground bus (4) to ground connection at supplying device (Rexroth IndraDrive supply unit or Rexroth IndraDrive drive controller HCS).

**Alternative 2** Connect cable shield to a ground bus. The cable length between device and ground bus mustn't be more than a maximum of 1 m. For this purpose, prepare the motor cable in accordance with the description below:

## Connections of the Components in the Drive System

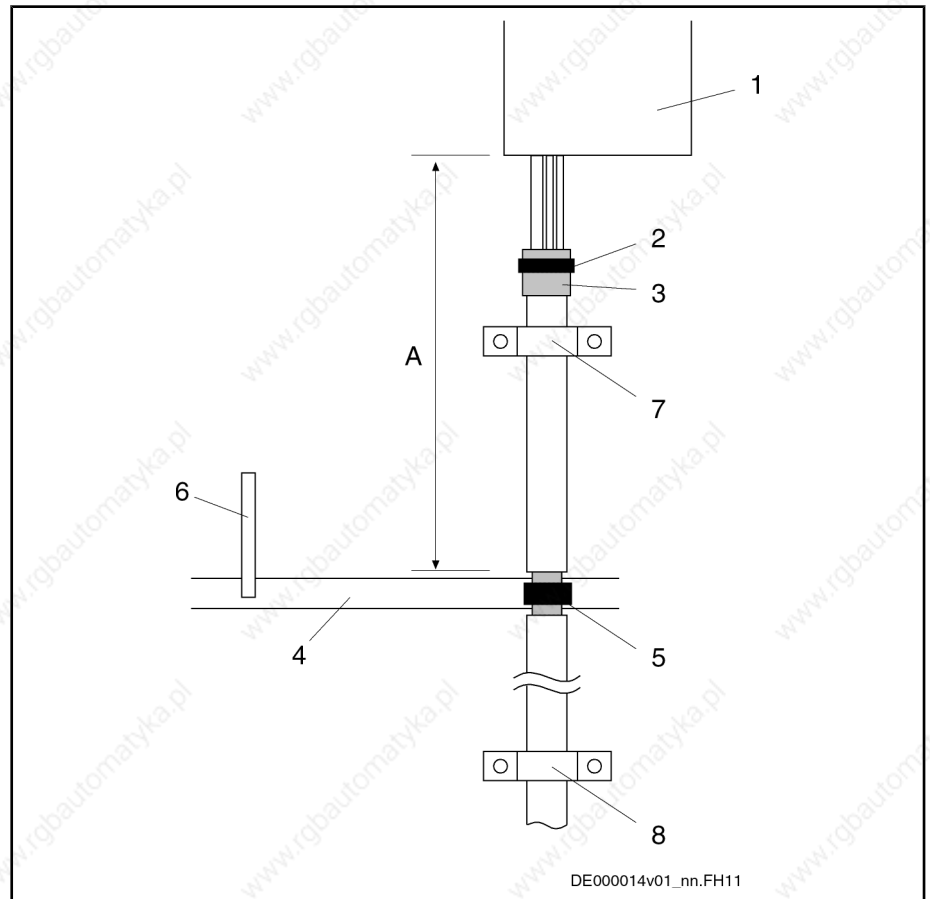

- 1: drive controller  
 2: cable tie  
 3: overall shield of the motor power cable folded back  
 4: ground bus in control cabinet  
 5: connection between overall shield of motor power cable laying bare and ground bus  
 6: connection of ground bus to supplying device  
 7: strain relief (as near as possible to the drive-side cable end)  
 8: strain relief (as near as possible to exit point from control cabinet)  
 A: cable length between ground bus and device: < 1 m

Fig. 13-22: Shield connection, alternative 2

- With a cable tie (2) press the drive-side cable end in such a way that the shields of the two inner pairs of wires (motor temperature, holding brake) have good contact with the overall shield of the motor power cable (3). (If you use your own cable, make sure the shields of the two inner pairs of wires are in contact with the overall shield.)
- On the level of the ground bus in the control cabinet remove a piece of the cable sheath from the motor power cable in order to lay bare the overall shield (5).
- Connect overall shield (5) to ground bus in the control cabinet with an appropriate connection (clip). The connection must have a cross section of at least 10 mm<sup>2</sup>.
- With a cable (6) (line cross section at least 10 mm<sup>2</sup>), connect ground bus (4) to ground connection at supplying device (Rexroth IndraDrive supply unit or Rexroth IndraDrive drive controller HCS).
- Make sure there is sufficient strain relief for the motor power cable as near as possible to the drive-side cable end (7).

## Connections of the Components in the Drive System

- In addition, make sure there is sufficient strain relief for the motor power cable as near as possible to the exit point from the control cabinet of the motor power cable (8).



Do not remove the shield of the motor cable between ground bus and device.

If the motor power cables are routed to the control cabinet via flange sockets, directly connect the shield to the wall of the control cabinet over a large surface area via the housing of the flange socket. Make sure there is sufficient separate strain relief.

**Bonding Conductor**

Bad ground connection between motor housing and control cabinet housing, as well as long motor cables, can require additional routing of a bonding conductor of a cross section of normally 10 mm<sup>2</sup> between control cabinet housing and motor housing.



For cable lengths of more than 50 m, the cross section should be at least 35 mm<sup>2</sup>.

**Shield Connection of Kit Motors**

For kit motors, make sure that the connection lines are run in shielded form or under metal between winding and terminal box, if the terminal box is not directly mounted on the spindle case.

**Shield Connection of Linear Motors**

For linear motors, connect the shield of the connection cable between primary part and terminal box via clips to machine housing or metal shell.

**Shielding of Motor Temperature Monitoring and Motor Holding Brake**

The inner shields of motor temperature monitor and motor holding brake in the motor cable are connected to the drive controller at one end.

## 13.2 Overall Connection Diagrams of the System

To draw up the overall connection diagrams there are **ePlan macros** of the devices available. Please ask our sales representative.

# 14 Accessories in the Drive System Rexroth IndraDrive

## 14.1 HAS01 Basic Accessories

### 14.1.1 Type Code



The following figure illustrates the basic structure of the type code. Our sales representative will help you with the current status of available versions.

Abbrev.	Column	1	2	3	4	5	6	7	8	9	0	1	2	3	4	5	6	7	8	9	0	1	2	3	4	5	6	7	8	9	0	1	2	3	4	5	6	7	8	9	0	
Example:		H	A	S	0	1	.	1	-	0	5	0	-	0	7	2	-	M	2																							

- 1. Product**
  - 1.1 Accessories  
IndraDrive ... = HAS
- 2. Line**
  - 2.1 Basic kit ..... = 01
- 3. Design**
  - 3.1 1 ..... = 1
- 4. Device width**
  - 4.1 50 ..... = 050
  - 4.2 65 ..... = 065
  - 4.3 75 ..... = 075
  - 4.4 100 ..... = 100
  - 4.5 105 ..... = 105
  - 4.6 125 ..... = 125
  - 4.7 150 ..... = 150
  - 4.8 175 ..... = 175
  - 4.9 200 ..... = 200
  - 4.10 225 ..... = 225
  - 4.11 250 ..... = 250
  - 4.12 350 ..... = 350
- 5. Bus-bar**
  - 5.1 with cross-sectional area 48 mm<sup>2</sup> ..... = 048
  - 5.2 with cross-sectional area 72 mm<sup>2</sup> ..... = 072
  - 5.3 without ..... = NNN ①
- 6. Other design**
  - 6.1 Compact units ..... = CN
  - 6.2 Compact unit, HCS04.1E-x500 ..... = CA
  - 6.3 Modular units in line "02" ..... = M2
  - 6.4 Modular units ..... = MN
  - 6.5 none ..... = NN

**Note:**  
① only for device width of "065", "105", "125", "150", "175", "225", "250" and "350"

DT000003v01\_en.fh

Fig. 14-1: Type code HAS01.1

### 14.1.2 Brief Description

Accessories for mounting and installing the drive controllers in a group, i.e. next to each other.



## Accessories in the Drive System Rexroth IndraDrive

As adjusted to the device widths, we distinguish 3 types:

- HAS01 **without** contact bars (-NNN)
- HAS01 **with** contact bars (-072-) to connect the DC buses
- HAS01 **with** contact bars (-072-) to connect the DC buses and joint bars to connect the equipment grounding conductors of the devices



Observe that the contact bars of the basic accessories HAS01 are used for connection to the drive controller on the **left-hand** side.

### 14.1.3 Usage

The HAS01 accessories are used to

- fix the drive controllers to a mounting surface
- connect the DC bus connections of drive controllers
- connect the 24V supply of drive controllers of the Rexroth IndraDrive M range
- connect the equipment grounding conductor from drive controller to drive controller or supply unit
- increase the current carrying capacity of the contact bars in the DC bus for high-performance devices (by means of the parts "end piece" and "bar" in HAS01; see chapter "Assignment")



#### Use of the parts "end piece" and "bar"

For high-performance devices, you have to mount the end pieces and bars contained in the HAS01 accessory (see chapter "Assignment").

See sections "Terminal Block L+, L- (DC Bus Connection)" and "Terminal Block, 24V - 0V (24V Supply)" in the Project Planning Manual "Rexroth IndraDrive, Supply Units and Power Sections".

### 14.1.4 Assignment

The accessories are assigned to the individual devices depending on the device width (see section "Type Code").

Device type		Width / mm	Accessory HAS01.1-	
				with "end piece"
HMS01.1N-	W0020	50	050	-
	W0036	50	050	-
	W0054	75	075	-
	W0070	100	100	-
	W0110	125	125	-
	W0150	150	150	-
	W0210	200	200	■
	W0350	350	350	■



## Accessories in the Drive System Rexroth IndraDrive

Device type		Width / mm	Accessory HAS01.1-		
				with "end piece"	
HMD01.1N-	W0012	50	050	-	
	W0020	50	050	-	
	W0036	75	075	-	
HMS02.1N-	W0028	49.5	050	-	
	W0054	74.5	075	-	
HLB01.1	D	100	100	-	
HLC01.1	D	100	100	-	
HMV01.1E-	W0030	150	150	-	
	W0075	250	250	■	
	W0120	350	350	■	
HMV01.1R-	W0018	175	175	-	
	W0045	250	250	■	
	W0065	350	350	■	
	W0120	350	350	■	
HMV02.1R-	W0015	150	150	-	
	W0012	65	065	-	
	W0028	65	065	-	
	W0054	105	105	-	
HCS02.1N-	W0070	105	105	-	
	HLB01.1	C	65	065	-
	HLC01.1	C	50	050	-
	HCS03.1N-	W0070	125	125	-
W0100		225	225	-	
W0150		225	225	-	
W0210		350	350	■	

Fig. 14-2: Device width

### 14.1.5 Scope of Supply

Components of the accessory: see accompanying notes

Accessories in the Drive System Rexroth IndraDrive

















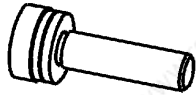

<p>Made in Germany 109-1253-4801-05</p> <p style="text-align: right;"><b>Rexroth Bosch Group</b></p> <h2 style="text-align: center;">HAS01.1-050-072-MN</h2>  <p style="text-align: center;">R911306620</p> <table border="1" style="width: 100%; border-collapse: collapse; margin-top: 10px;"> <thead> <tr> <th style="width: 5%;">Stck</th> <th style="width: 85%;">Benennung</th> <th style="width: 10%;">MNR</th> </tr> </thead> <tbody> <tr> <td>12</td> <td>SCHR-LIN-M 6,0X25,0-K-8.8-ISO7045-ZN-Z41</td> <td>R911276873</td> </tr> <tr> <td>2</td> <td>SCHR-LIN-M 3,0X 8,0-T-8.8-ISO7045-ZN-ML*</td> <td>R911294165</td> </tr> <tr> <td>1</td> <td>SCHILD-KLEBE UL-CSA WARNHINWEIS EN/FR 30</td> <td>R911309089</td> </tr> <tr> <td>4</td> <td>SCHIENE-VERBINDUNG HAS01.1-050-072 ISOL.</td> <td>R911309945</td> </tr> <tr> <td>2</td> <td>SCHIENE-VERBINDUNG HAS01.1-032-042</td> <td>R911311751</td> </tr> <tr> <td>1</td> <td>LASCHE HMD/HMS01.1 ERDUNG</td> <td>R911294924</td> </tr> <tr> <td>5</td> <td>KAB-BIND-D045-B4,8-C085-N220-TR-PA-*****</td> <td>R911222614</td> </tr> <tr> <th>Stck</th> <th>Benennung</th> <th>MNR</th> </tr> </tbody> </table>	Stck	Benennung	MNR	12	SCHR-LIN-M 6,0X25,0-K-8.8-ISO7045-ZN-Z41	R911276873	2	SCHR-LIN-M 3,0X 8,0-T-8.8-ISO7045-ZN-ML*	R911294165	1	SCHILD-KLEBE UL-CSA WARNHINWEIS EN/FR 30	R911309089	4	SCHIENE-VERBINDUNG HAS01.1-050-072 ISOL.	R911309945	2	SCHIENE-VERBINDUNG HAS01.1-032-042	R911311751	1	LASCHE HMD/HMS01.1 ERDUNG	R911294924	5	KAB-BIND-D045-B4,8-C085-N220-TR-PA-*****	R911222614	Stck	Benennung	MNR	<p style="text-align: center;"><b>BEIPACKZETTEL HAS01.1-050-072-MN</b></p> <table border="1" style="width: 100%; border-collapse: collapse;"> <thead> <tr> <th style="width: 5%;">Stck</th> <th style="width: 85%;">Benennung</th> <th style="width: 10%;">MNR</th> </tr> </thead> <tbody> <tr> <td>5</td> <td>KAB-BIND-D045-B4,8-C085-N220-TR-PA-*****</td> <td>R911222614</td> </tr> <tr> <td style="text-align: center;">DB146855</td> <td style="text-align: center;"></td> <td style="text-align: right;">1:4</td> </tr> <tr> <td>1</td> <td>LASCHE HMD/HMS01.1 ERDUNG</td> <td>R911294924</td> </tr> <tr> <td style="text-align: center;">DB139203</td> <td style="text-align: center;"></td> <td style="text-align: right;">1:2</td> </tr> <tr> <td>2</td> <td>SCHIENE-VERBINDUNG HAS01.1-032-042</td> <td>R911311751</td> </tr> <tr> <td style="text-align: center;">DB184465</td> <td style="text-align: center;"></td> <td style="text-align: right;">1:2</td> </tr> <tr> <td>4</td> <td>SCHIENE-VERBINDUNG HAS01.1-050-072 ISOL.</td> <td>R911309945</td> </tr> <tr> <td style="text-align: center;">DB166230</td> <td style="text-align: center;"></td> <td style="text-align: right;">1:2</td> </tr> <tr> <td>1</td> <td>SCHILD-KLEBE UL-CSA WARNHINWEIS EN/FR 30</td> <td>R911309089</td> </tr> <tr> <td style="text-align: center;">DB175105</td> <td style="text-align: center;"></td> <td style="text-align: right;">2:5</td> </tr> <tr> <td>2</td> <td>SCHR-LIN-M 3,0X 8,0-T-8.8-ISO7045-ZN-ML*</td> <td>R911294165</td> </tr> <tr> <td style="text-align: center;">DB-40050</td> <td style="text-align: center;"></td> <td style="text-align: right;">1:1</td> </tr> <tr> <td>12</td> <td>SCHR-LIN-M 6,0X25,0-K-8.8-ISO7045-ZN-Z41</td> <td>R911276873</td> </tr> <tr> <td style="text-align: center;">DB-54729</td> <td style="text-align: center;"></td> <td style="text-align: right;">1:1</td> </tr> </tbody> </table> <table border="1" style="width: 100%; border-collapse: collapse; margin-top: 10px;"> <tr> <td style="width: 20%;">Datum</td> <td style="width: 20%;">2004-02-20</td> <td style="width: 20%;">Benennung</td> <td style="width: 40%;">BEIPACKZETTEL HAS01.1-050-072-MN</td> </tr> <tr> <td>Name</td> <td>Hirt</td> <td>Material-Nr.</td> <td>R911306606</td> </tr> <tr> <td>Material-Nr.</td> <td>R911306606</td> <td>Zeich-Nr.</td> <td>109-1253-4201-06</td> </tr> <tr> <td>Datei</td> <td>DB166239</td> <td>Ers.durch</td> <td>..</td> </tr> <tr> <td></td> <td></td> <td>AEM-Nr.</td> <td>5-017509</td> </tr> </table>	Stck	Benennung	MNR	5	KAB-BIND-D045-B4,8-C085-N220-TR-PA-*****	R911222614	DB146855		1:4	1	LASCHE HMD/HMS01.1 ERDUNG	R911294924	DB139203		1:2	2	SCHIENE-VERBINDUNG HAS01.1-032-042	R911311751	DB184465		1:2	4	SCHIENE-VERBINDUNG HAS01.1-050-072 ISOL.	R911309945	DB166230		1:2	1	SCHILD-KLEBE UL-CSA WARNHINWEIS EN/FR 30	R911309089	DB175105		2:5	2	SCHR-LIN-M 3,0X 8,0-T-8.8-ISO7045-ZN-ML*	R911294165	DB-40050		1:1	12	SCHR-LIN-M 6,0X25,0-K-8.8-ISO7045-ZN-Z41	R911276873	DB-54729		1:1	Datum	2004-02-20	Benennung	BEIPACKZETTEL HAS01.1-050-072-MN	Name	Hirt	Material-Nr.	R911306606	Material-Nr.	R911306606	Zeich-Nr.	109-1253-4201-06	Datei	DB166239	Ers.durch	..			AEM-Nr.	5-017509
Stck	Benennung	MNR																																																																																											
12	SCHR-LIN-M 6,0X25,0-K-8.8-ISO7045-ZN-Z41	R911276873																																																																																											
2	SCHR-LIN-M 3,0X 8,0-T-8.8-ISO7045-ZN-ML*	R911294165																																																																																											
1	SCHILD-KLEBE UL-CSA WARNHINWEIS EN/FR 30	R911309089																																																																																											
4	SCHIENE-VERBINDUNG HAS01.1-050-072 ISOL.	R911309945																																																																																											
2	SCHIENE-VERBINDUNG HAS01.1-032-042	R911311751																																																																																											
1	LASCHE HMD/HMS01.1 ERDUNG	R911294924																																																																																											
5	KAB-BIND-D045-B4,8-C085-N220-TR-PA-*****	R911222614																																																																																											
Stck	Benennung	MNR																																																																																											
Stck	Benennung	MNR																																																																																											
5	KAB-BIND-D045-B4,8-C085-N220-TR-PA-*****	R911222614																																																																																											
DB146855		1:4																																																																																											
1	LASCHE HMD/HMS01.1 ERDUNG	R911294924																																																																																											
DB139203		1:2																																																																																											
2	SCHIENE-VERBINDUNG HAS01.1-032-042	R911311751																																																																																											
DB184465		1:2																																																																																											
4	SCHIENE-VERBINDUNG HAS01.1-050-072 ISOL.	R911309945																																																																																											
DB166230		1:2																																																																																											
1	SCHILD-KLEBE UL-CSA WARNHINWEIS EN/FR 30	R911309089																																																																																											
DB175105		2:5																																																																																											
2	SCHR-LIN-M 3,0X 8,0-T-8.8-ISO7045-ZN-ML*	R911294165																																																																																											
DB-40050		1:1																																																																																											
12	SCHR-LIN-M 6,0X25,0-K-8.8-ISO7045-ZN-Z41	R911276873																																																																																											
DB-54729		1:1																																																																																											
Datum	2004-02-20	Benennung	BEIPACKZETTEL HAS01.1-050-072-MN																																																																																										
Name	Hirt	Material-Nr.	R911306606																																																																																										
Material-Nr.	R911306606	Zeich-Nr.	109-1253-4201-06																																																																																										
Datei	DB166239	Ers.durch	..																																																																																										
		AEM-Nr.	5-017509																																																																																										

Fig.14-3: Accompanying note

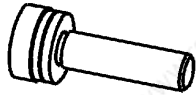
Accessories in the Drive System Rexroth IndraDrive

Made in Germany  
109-1253-4802-05

**Rexroth  
Bosch Group**

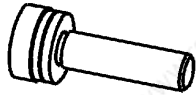



## HAS01.1-075-072-MN



R911306619

12	SCHR-LIN-M 6,0X25,0-K-8-8-ISO7045-ZN-Z41	R911276873
2	SCHR-LIN-M 3,0X 8,0-T-8-8-ISO7045-ZN-ML*	R911294165
1	SCHILD-KLEBE UL-CSA WARNHINWEIS EN/FR 30	R911309089
4	SCHIENE-VERBINDUNG HAS01.1-075-072 ISOL.	R911309946
2	SCHIENE-VERBINDUNG HAS01.1-032-042	R911311751
1	LASCHE HMD/HMS01.1 ERDUNG	R911294924
5	KAB-BIND-D045-B4,8-C085-N220-TR-PA-*****	R911222614
<b>Stck</b>	<b>Benennung</b>	<b>MNR</b>

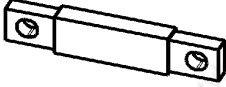
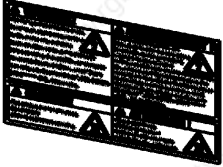
**BEIPACKZETTEL HAS01.1-075-072-MN**

Stck	Benennung	MNR
5	KAB-BIND-D045-B4,8-C085-N220-TR-PA-*****	R911222614
DB140855		1:4
1	LASCHE HMD/HMS01.1 ERDUNG	R911294924
DB139203		1:2
2	SCHIENE-VERBINDUNG HAS01.1-032-042	R911311751
DB184465		1:2
4	SCHIENE-VERBINDUNG HAS01.1-075-072 ISOL.	R911309946
DB166231		1:2
1	SCHILD-KLEBE UL-CSA WARNHINWEIS EN/FR 30	R911309089
DB175705		2:5
2	SCHR-LIN-M 3,0X 8,0-T-8-8-ISO7045-ZN-ML*	R911294165
DB-40050		1:1
12	SCHR-LIN-M 6,0X25,0-K-8-8-ISO7045-ZN-Z41	R911276873
DB-54729		1:1

Datum	2004-02-20	Benennung
Name	Hirt	BEIPACKZETTEL HAS01.1-075-072-MN
Material-Nr.	R911306607	Zeich-Nr. 109-1253-4202-06
Datei	DB166241	Ers.durch ... AEM-Nr. 5-017509

Fig.14-4: Accompanying note

Accessories in the Drive System Rexroth IndraDrive

Made in Germany  
109-1253-4803-05

**Rexroth  
Bosch Group**







## HAS01.1-100-072-MN

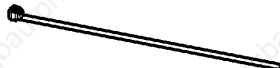

R911306621

14	SCHR-LIN-M 6,0X25,0-K-8.8-ISO7045-ZN-Z41	R911276873
2	SCHR-LIN-M 3,0X 8,0-T-8.8-ISO7045-ZN-ML*	R911294165
1	SCHILD-KLEBE UL-CSA WARNHINWEIS EN/FR 30	R911309089
4	SCHIENE-VERBINDUNG HAS01.1-100-072 ISOL.	R911309947
2	SCHIENE-VERBINDUNG HAS01.1-032-042	R911311751
1	LASCHE HMD/HMS01.1 ERDUNG	R911294924
5	KAB-BIND-D045-B4,8-C085-N220-TR-PA-*****	R911222614
Stck	Benennung	MNR

**BEIPACKZETTEL HAS01.1-100-072-MN**

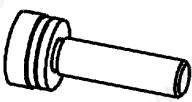
Stck	Benennung	MNR
5	KAB-BIND-D045-B4,8-C085-N220-TR-PA-*****	R911222614
DB146855		1:4
1	LASCHE HMD/HMS01.1 ERDUNG	R911294924
DB139203		1:2
2	SCHIENE-VERBINDUNG HAS01.1-032-042	R911311751
DB184465		1:2
4	SCHIENE-VERBINDUNG HAS01.1-100-072 ISOL.	R911309947
DB166232		1:2
1	SCHILD-KLEBE UL-CSA WARNHINWEIS EN/FR 30	R911309089
DB175105		2:5
2	SCHR-LIN-M 3,0X 8,0-T-8.8-ISO7045-ZN-ML*	R911294165
DB-40050		1:1
14	SCHR-LIN-M 6,0X25,0-K-8.8-ISO7045-ZN-Z41	R911276873
DB-54729		1:1

Datum	2004-02-20	Benennung	BEIPACKZETTEL HAS01.1-100-072-MN	
Name	Hirt	Material-Nr.	R911306608	Zeich-Nr. 109-1253-4203-06
Datei	DB166243	Ers.durch	..	AEM-Nr. 5-017509

Fig.14-5: Accompanying note

Accessories in the Drive System Rexroth IndraDrive

Made in Germany  
109-1253-4845-00

**Rexroth  
Bosch Group**







## HAS01.1-125-072-MN



R911315182

17	SCHR-LIN-M 6,0X25,0-K-8-8-ISO7045-ZN-Z41	R911276873
2	SCHR-LIN-M 3,0X 8,0-T-8-8-ISO7045-ZN-ML*	R911294165
1	SCHILD-KLEBE UL-CSA WARNHINWEIS EN/FR 30	R911309089
4	SCHIENE-VERBINDUNG HAS01.1-125-072 ISOL.	R911309948
2	SCHIENE-VERBINDUNG HAS01.1-032-042	R911311751
1	LASCHE HMD/HMS01.1 ERDUNG	R911294924
5	KAB-BIND-D045-B4,8-C085-N220-TR-PA-*****	R911222614
<b>Stck</b>	<b>Benennung</b>	<b>MNR</b>

**BEIPACKZETTEL HAS01.1-125-072-MN**

Stck	Benennung	MNR
5	KAB-BIND-D045-B4,8-C085-N220-TR-PA-*****	R911222614
DB140835		1:4
1	LASCHE HMD/HMS01.1 ERDUNG	R911294924
DB139203		1:2
2	SCHIENE-VERBINDUNG HAS01.1-032-042	R911311751
DB184765		1:2
4	SCHIENE-VERBINDUNG HAS01.1-125-072 ISOL.	R911309948
DB166347		1:2
1	SCHILD-KLEBE UL-CSA WARNHINWEIS EN/FR 30	R911309089
DB175705		2:5
2	SCHR-LIN-M 3,0X 8,0-T-8-8-ISO7045-ZN-ML*	R911294165
DB-40050		1:1
17	SCHR-LIN-M 6,0X25,0-K-8-8-ISO7045-ZN-Z41	R911276873
DB-54729		1:1

<b>Datum</b>	2005-10-28	<b>Benennung</b>	BEIPACKZETTEL HAS01.1-125-072-MN
<b>Name</b>	rainhirt	<b>Material-Nr.</b>	R911315185
<b>Material-Nr.</b>	R911315185	<b>Zeich-Nr.</b>	109-1253-4279-00
<b>Datei</b>	DB193171	<b>Ers.durch</b>	...
		<b>AEM-Nr.</b>	5-0

Fig. 14-6: Accompanying note

Accessories in the Drive System Rexroth IndraDrive

Made in Germany  
109-1253-4804-05

**Rexroth  
Bosch Group**







## HAS01.1-150-072-MN



R911306622

17	SCHR-LIN-M 6,0X25,0-K-8.8-ISO7045-ZN-Z41	R911276873
2	SCHR-LIN-M 3,0X 8,0-T-8.8-ISO7045-ZN-ML*	R911294165
1	SCHILD-KLEBE UL-CSA WARNHINWEIS EN/FR 30	R911309089
4	SCHIENE-VERBINDUNG HAS01.1-150-072 ISOL.	R911309949
2	SCHIENE-VERBINDUNG HAS01.1-032-042	R911311751
1	LASCHE HMD/HMS01.1 ERDUNG	R911294924
5	KAB-BIND-D045-B4,8-C085-N220-TR-PA-*****	R911222614
<b>Stck</b>	<b>Benennung</b>	<b>MNR</b>

**BEIPACKZETTEL HAS01.1-150-072-MN**

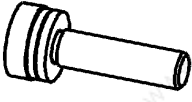
Stck	Benennung	MNR
5	KAB-BIND-D045-B4,8-C085-N220-TR-PA-*****	R911222614
DB146855		1:4
1	LASCHE HMD/HMS01.1 ERDUNG	R911294924
DB139203		1:2
2	SCHIENE-VERBINDUNG HAS01.1-032-042	R911311751
DB184465		1:2
4	SCHIENE-VERBINDUNG HAS01.1-150-072 ISOL.	R911309949
DB166233		1:2
1	SCHILD-KLEBE UL-CSA WARNHINWEIS EN/FR 30	R911309089
DB175105		2:5
2	SCHR-LIN-M 3,0X 8,0-T-8.8-ISO7045-ZN-ML*	R911294165
DB-40050		1:1
17	SCHR-LIN-M 6,0X25,0-K-8.8-ISO7045-ZN-Z41	R911276873
DB-54729		1:1

<b>Datum</b>	2004-02-20	<b>Benennung</b>	BEIPACKZETTEL HAS01.1-150-072-MN	
<b>Name</b>	Hirt	<b>Material-Nr.</b>	R911306614	<b>Zeich-Nr.</b> 109-1253-4204-06
<b>Datei</b>	DB166245	<b>Ers.durch</b>	..	<b>AEM-Nr.</b> 5-017509

Fig.14-7: Accompanying note

Accessories in the Drive System Rexroth IndraDrive

Made in Germany  
109-1253-4809-02



## HAS01.1-150-NNN-MN



R911306629

2	WERKZ-BETAETIGUNG STECK-FK RM5,00	R911295969
13	SCHR-LIN-M 6,0X25,0-K-8.8-ISO7045-ZN-Z41	R911276873
2	SCHR-LIN-M 3,0X 8,0-T-8.8-ISO7045-ZN-ML*	R911294165
1	SCHILD-KLEBE UL-CSA WARNHINWEIS EN/FR 30	R911309089
5	KAB-BIND-D045-B4,8-C085-N220-TR-PA-*****	R911222614
Stck	Benennung	MNR

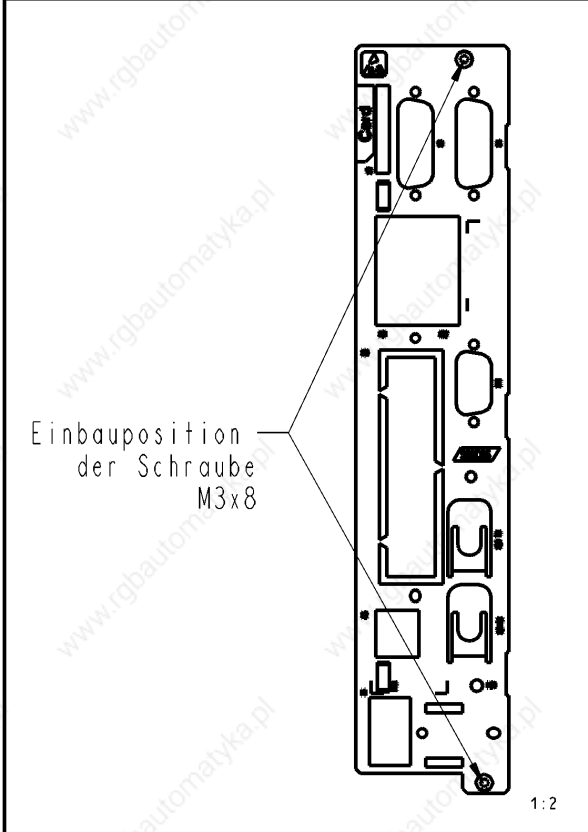

1:2

### BEIPACKZETTEL HAS01.1-150-NNN-MN

Stck	Benennung	MNR
5	KAB-BIND-D045-B4,8-C085-N220-TR-PA-*****	R911222614
1	SCHILD-KLEBE UL-CSA WARNHINWEIS EN/FR 30	R911309089
2	SCHR-LIN-M 3,0X 8,0-T-8.8-ISO7045-ZN-ML*	R911294165
13	SCHR-LIN-M 6,0X25,0-K-8.8-ISO7045-ZN-Z41	R911276873
2	WERKZ-BETAETIGUNG STECK-FK RM5,00	R911295969

Datum	2004-02-20	Benennung
Name	Hirt	BEIPACKZETTEL HAS01.1-150-NNN-MN
Material-Nr.	R911306635	Zeich-Nr. 109-1253-4217-02
Datei	DB166332	Ers.durch .. AEM-Nr. 5-010883

Fig. 14-8: Accompanying note



Accessories in the Drive System Rexroth IndraDrive

Made in Germany  
109-1253-4805-05

**Rexroth  
Bosch Group**







## HAS01.1-175-072-MN

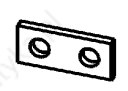

R911306623

17	SCHR-LIN-M 6,0X25,0-K-8.8-ISO7045-ZN-Z41	R911276873
2	SCHR-LIN-M 3,0X 8,0-T-8.8-ISO7045-ZN-ML*	R911294165
1	SCHILD-KLEBE UL-CSA WARNHINWEIS EN/FR 30	R911309089
4	SCHIENE-VERBINDUNG HAS01.1-175-072 ISOL.	R911309950
2	SCHIENE-VERBINDUNG HAS01.1-032-042	R911311751
1	LASCHE HMD/HMS01.1 ERDUNG	R911294924
5	KAB-BIND-D045-B4,8-C085-N220-TR-PA-*****	R911222614
Stck	Benennung	MNR

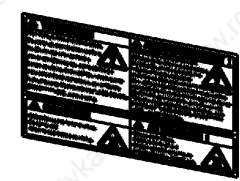
**BEIPACKZETTEL HAS01.1-175-072-MN**

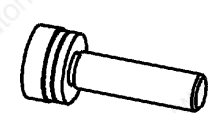
Stck	Benennung	MNR
5	KAB-BIND-D045-B4,8-C085-N220-TR-PA-*****	R911222614
DB146855		1:4
1	LASCHE HMD/HMS01.1 ERDUNG	R911294924
DB139203		1:2
2	SCHIENE-VERBINDUNG HAS01.1-032-042	R911311751
DB184465		1:2
4	SCHIENE-VERBINDUNG HAS01.1-175-072 ISOL.	R911309950
DB166234		7:20
1	SCHILD-KLEBE UL-CSA WARNHINWEIS EN/FR 30	R911309089
DB175105		2:5
2	SCHR-LIN-M 3,0X 8,0-T-8.8-ISO7045-ZN-ML*	R911294165
DB-40050		1:1
17	SCHR-LIN-M 6,0X25,0-K-8.8-ISO7045-ZN-Z41	R911276873
DB-54729		1:1

Datum	2004-02-20	Benennung	BEIPACKZETTEL HAS01.1-175-072-MN		
Name	Hirt	Material-Nr.	R911306615	Zeich-Nr.	109-1253-4205-06
Datei	DB166274	Ers.durch	..	AEM-Nr.	5-017509

Fig.14-9: Accompanying note

Accessories in the Drive System Rexroth IndraDrive

Made in Germany  
109-1253-4810-02



## HAS01.1-175-NNN-MN



R911306630



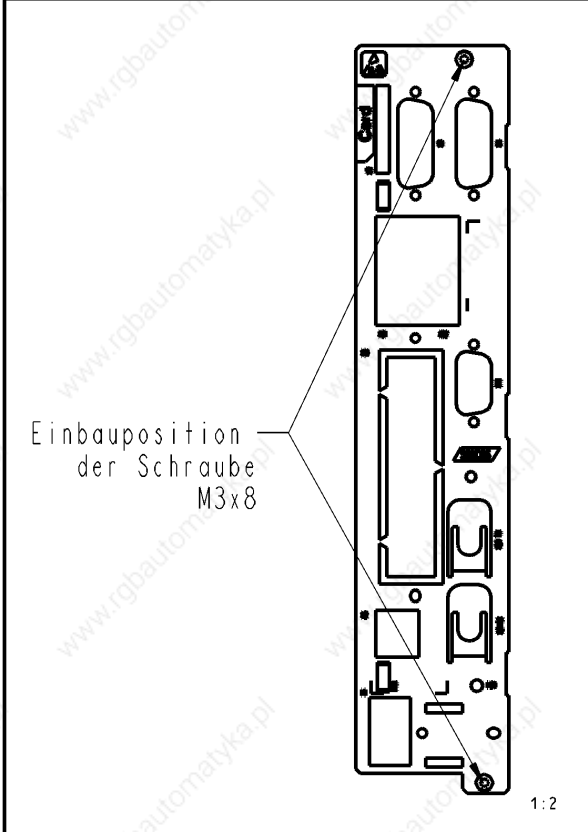

2	WERKZ-BETAETIGUNG STECK-FK RM5,00	R911295969
13	SCHR-LIN-M 6,0X25,0-K-8.8-ISO7045-ZN-Z4I	R911276873
2	SCHR-LIN-M 3,0X 8,0-T-8.8-ISO7045-ZN-ML*	R911294165
1	SCHILD-KLEBE UL-CSA WARNHINWEIS EN/FR 30	R911309089
5	KAB-BIND-D045-B4,8-C085-N220-TR-PA-*****	R911222614
<b>Stck</b>	<b>Benennung</b>	<b>MNR</b>

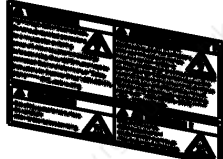

Einbauposition  
der Schraube  
M3x8

1:2

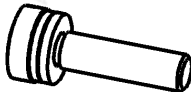
### BEIPACKZETTEL HAS01.1-175-NNN-MN

Stck	Benennung	MNR
5	KAB-BIND-D045-B4,8-C085-N220-TR-PA-*****	R911222614
DB146855		1:4
1	SCHILD-KLEBE UL-CSA WARNHINWEIS EN/FR 30	R911309089
DB175105		2:5
2	SCHR-LIN-M 3,0X 8,0-T-8.8-ISO7045-ZN-ML*	R911294165
DB_40060		1:1
13	SCHR-LIN-M 6,0X25,0-K-8.8-ISO7045-ZN-Z4I	R911276873
DB_54729		1:1
2	WERKZ-BETAETIGUNG STECK-FK RM5,00	R911295969
DB144739		1:1

Datum	2004-02-20	Benennung	BEIPACKZETTEL HAS01.1-175-NNN-MN
Name	Hirt	Material-Nr.	R911306636
Zeich-Nr.	109-1253-4218-02	Erst-durch	...
Datei	DB166319	AEM-Nr.	5-010883

Fig. 14-10: Accompanying note

Accessories in the Drive System Rexroth IndraDrive

Made in Germany  
109-1253-4806-05

**Rexroth  
Bosch Group**





## HAS01.1-200-072-MN



R911306624

17	SCHR-LIN-M 6,0x25,0-K-8.8-ISO7045-ZN-Z41	R911276873
2	SCHR-LIN-M 3,0x 8,0-T-8.8-ISO7045-ZN-ML*	R911294165
1	SCHILD-KLEBE UL-CSA WARNHINWEIS EN/FR 30	R911309089
4	SCHIENE-VERBINDUNG HAS01.1-200-072 ISOL.	R911309951
2	SCHIENE-VERBINDUNG HAS01.1-032-042	R911311751
1	LASCHE HMD/HMS01.1 ERDUNG	R911294924
5	KAB-BIND-D045-B4,8-C085-N220-TR-PA-*****	R911222614
2	ENDSTUECK HAS01.1 SCHIENE-VERBINDUNG	R911311982
<b>Stck</b>	<b>Benennung</b>	<b>MNR</b>

### BEIPACKZETTEL HAS01.1-200-072-MN

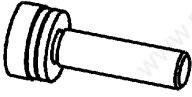
Stck	Benennung	MNR
DB139203		R911294924 1:2
DB164405		R911311751 1:2
DB166235		R911309951 7:20
DB175705		R911309089 2:5
DB-10060		R911294165 1:1
DB-54729		R911276873 1:1

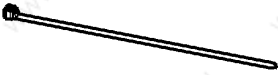
Stck	Benennung	MNR
DB137131		R911311982 1:2
DB146855		R911222614 1:4

Datum	2004-02-20	Benennung
Name	Hirt	BEIPACKZETTEL HAS01.1-200-072-MN
Material-Nr.	R911306616	Zeich-Nr. 109-1253-4206-06
Datei	DB166247	Ers.durch .. AEM-Nr. 5-017509

Fig.14-11: Accompanying note

Accessories in the Drive System Rexroth IndraDrive

Made in Germany  
109-1253-4807-06

**Rexroth  
Bosch Group**









## HAS01.1-250-072-MN



R911306625

1	SCHILD-KLEBE UL-CSA WARNHINWEIS EN/FR 30	R911309089
4	SCHIENE-VERBINDUNG HAS01.1-250-072 ISOL.	R911309953
2	SCHIENE-VERBINDUNG HAS01.1-032-042	R911311751
1	LASCHE HMD/HMS01.1 ERDUNG	R911294924
17	KOMBI-SCHRAUBE ZISO10644-M6X25-8.8 &	R911276873
5	KAB-BIND-D045-B4,8-C085-N220-TR-PA-*****	R911222614
2	FLACHKOPFSCHRAUBE ISO14583-M3X8-8.8 &	R911294165
2	ENDSTUECK HAS01.1 SCHIENE-VERBINDUNG	R911311982
<b>Stck</b>	<b>Benennung</b>	<b>MNR</b>

**BEIPACKZETTEL HAS01.1-250-072-MN**

Stck	Benennung	MNR
2	ENDSTUECK HAS01.1 SCHIENE-VERBINDUNG	R911311982
DB18131		1:2
2	FLACHKOPFSCHRAUBE ISO14583-M3X8-8.8 &	R911294165
DB-40660		1:1
5	KAB-BIND-D045-B4,8-C085-N220-TR-PA-*****	R911222614
DB146855		1:4
17	KOMBI-SCHRAUBE ZISO10644-M6X25-8.8 &	R911276873
DB-51729		1:1
1	LASCHE HMD/HMS01.1 ERDUNG	R911294924
DB139203		1:2
2	SCHIENE-VERBINDUNG HAS01.1-032-042	R911311751
DB184465		1:2
4	SCHIENE-VERBINDUNG HAS01.1-250-072 ISOL.	R911309953
DB166236		1:4
1	SCHILD-KLEBE UL-CSA WARNHINWEIS EN/FR 30	R911309089
DB175105		2:5

Datum	2004-02-20	Benennung	BEIPACKZETTEL HAS01.1-250-072-MN
Name	Hirt	Material-Nr.	R911306617
Zeich-Nr.	109-1253-4207-07	Ers.durch	...
Datei	DB166276	AEM-Nr.	5-036224

Fig. 14-12: Accompanying note

Accessories in the Drive System Rexroth IndraDrive

<p>Made in Germany 109-1253-4811-04</p> <p style="text-align: right;"><b>Rexroth Bosch Group</b></p> <h2 style="text-align: center;">HAS01.1-250-NNN-MN</h2>  <p style="text-align: center;">R911306631</p> <table border="1" style="width: 100%; border-collapse: collapse; margin-top: 10px;"> <tr> <td style="width: 5%;">1</td> <td style="width: 85%;">SCHILD-KLEBE UL-CSA WARNHINWEIS EN/FR 30</td> <td style="width: 10%;">R911309089</td> </tr> <tr> <td>13</td> <td>KOMBI-SCHRAUBE ZISO10644-M6X25-8.8 &amp;</td> <td>R911276873</td> </tr> <tr> <td>5</td> <td>KAB-BIND-D045-B4,8-C085-N220-TR-PA-*****</td> <td>R911222614</td> </tr> <tr> <td>2</td> <td>FLACHKOPFSCHRAUBE ISO14583-M3X8-8.8 &amp;</td> <td>R911294165</td> </tr> <tr> <td>2</td> <td>ENDSTUECK HAS01.1 SCHIENE-VERBINDUNG</td> <td>R911311982</td> </tr> <tr> <th>Stck</th> <th>Benennung</th> <th>MNR</th> </tr> </table>	1	SCHILD-KLEBE UL-CSA WARNHINWEIS EN/FR 30	R911309089	13	KOMBI-SCHRAUBE ZISO10644-M6X25-8.8 &	R911276873	5	KAB-BIND-D045-B4,8-C085-N220-TR-PA-*****	R911222614	2	FLACHKOPFSCHRAUBE ISO14583-M3X8-8.8 &	R911294165	2	ENDSTUECK HAS01.1 SCHIENE-VERBINDUNG	R911311982	Stck	Benennung	MNR	<p style="text-align: center;"><b>BEIPACKZETTEL HAS01.1-250-NNN-MN</b></p> <table border="1" style="width: 100%; border-collapse: collapse;"> <thead> <tr> <th style="width: 5%;">Stck</th> <th style="width: 85%;">Benennung</th> <th style="width: 10%;">MNR</th> </tr> </thead> <tbody> <tr> <td style="text-align: center;">2</td> <td>ENDSTUECK HAS01.1 SCHIENE-VERBINDUNG</td> <td style="text-align: right;">R911311982</td> </tr> <tr> <td style="text-align: center;">2</td> <td>FLACHKOPFSCHRAUBE ISO14583-M3X8-8.8 &amp;</td> <td style="text-align: right;">R911294165</td> </tr> <tr> <td style="text-align: center;">5</td> <td>KAB-BIND-D045-B4,8-C085-N220-TR-PA-*****</td> <td style="text-align: right;">R911222614</td> </tr> <tr> <td style="text-align: center;">13</td> <td>KOMBI-SCHRAUBE ZISO10644-M6X25-8.8 &amp;</td> <td style="text-align: right;">R911276873</td> </tr> <tr> <td style="text-align: center;">1</td> <td>SCHILD-KLEBE UL-CSA WARNHINWEIS EN/FR 30</td> <td style="text-align: right;">R911309089</td> </tr> </tbody> </table> <table border="1" style="width: 100%; border-collapse: collapse;"> <tr> <td style="width: 20%;">Datum</td> <td style="width: 20%;">2004-02-20</td> <td style="width: 60%;">Benennung</td> </tr> <tr> <td>Name</td> <td>Hirt</td> <td>BEIPACKZETTEL HAS01.1-250-NNN-MN</td> </tr> <tr> <td>Material-Nr.</td> <td>R911306637</td> <td>Zeich-Nr. 109-1253-4219-04</td> </tr> <tr> <td>Datei</td> <td>DB166334</td> <td>Ers.durch .. AEM-Nr. 5-036224</td> </tr> </table>	Stck	Benennung	MNR	2	ENDSTUECK HAS01.1 SCHIENE-VERBINDUNG	R911311982	2	FLACHKOPFSCHRAUBE ISO14583-M3X8-8.8 &	R911294165	5	KAB-BIND-D045-B4,8-C085-N220-TR-PA-*****	R911222614	13	KOMBI-SCHRAUBE ZISO10644-M6X25-8.8 &	R911276873	1	SCHILD-KLEBE UL-CSA WARNHINWEIS EN/FR 30	R911309089	Datum	2004-02-20	Benennung	Name	Hirt	BEIPACKZETTEL HAS01.1-250-NNN-MN	Material-Nr.	R911306637	Zeich-Nr. 109-1253-4219-04	Datei	DB166334	Ers.durch .. AEM-Nr. 5-036224
1	SCHILD-KLEBE UL-CSA WARNHINWEIS EN/FR 30	R911309089																																															
13	KOMBI-SCHRAUBE ZISO10644-M6X25-8.8 &	R911276873																																															
5	KAB-BIND-D045-B4,8-C085-N220-TR-PA-*****	R911222614																																															
2	FLACHKOPFSCHRAUBE ISO14583-M3X8-8.8 &	R911294165																																															
2	ENDSTUECK HAS01.1 SCHIENE-VERBINDUNG	R911311982																																															
Stck	Benennung	MNR																																															
Stck	Benennung	MNR																																															
2	ENDSTUECK HAS01.1 SCHIENE-VERBINDUNG	R911311982																																															
2	FLACHKOPFSCHRAUBE ISO14583-M3X8-8.8 &	R911294165																																															
5	KAB-BIND-D045-B4,8-C085-N220-TR-PA-*****	R911222614																																															
13	KOMBI-SCHRAUBE ZISO10644-M6X25-8.8 &	R911276873																																															
1	SCHILD-KLEBE UL-CSA WARNHINWEIS EN/FR 30	R911309089																																															
Datum	2004-02-20	Benennung																																															
Name	Hirt	BEIPACKZETTEL HAS01.1-250-NNN-MN																																															
Material-Nr.	R911306637	Zeich-Nr. 109-1253-4219-04																																															
Datei	DB166334	Ers.durch .. AEM-Nr. 5-036224																																															

Fig.14-13: Accompanying note

Accessories in the Drive System Rexroth IndraDrive

Made in Germany  
109-1253-4808-06

**Rexroth  
Bosch Group**







## HAS01.1-350-072-MN



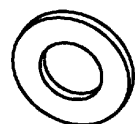
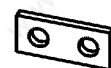

R911306626

4	SECHSKANTSCHRAUBE ISO4017-M10X30-8.8A1E	R913000050
17	SCHR-LIN-M 6,0X25,0-K-8.8-ISO7045-ZN-Z41	R911276873
2	SCHR-LIN-M 3,0X 8,0-T-8.8-ISO7045-ZN-ML*	R911294165
1	SCHILD-KLEBE UL-CSA WARNHINWEIS EN/FR 30	R911309089
4	SCHIENE-VERBINDUNG HAS01.1-350-072 ISOL.	R911309954
2	SCHIENE-VERBINDUNG HAS01.1-032-042	R911311751
4	SCHEIBE 10,50X 20,00X 2,00 DIN 125 A	R911213277
1	LASCHE HMD/HMS01.1 ERDUNG	R911294924
5	KAB-BIND-D045-B4,8-C085-N220-TR-PA-*****	R911222614
4	FEDERRING DIN127-B10-FST &	R911213251
2	ENDSTUECK HAS01.1 SCHIENE-VERBINDUNG	R911311982
<b>Stck</b>	<b>Benennung</b>	<b>MN</b>

### BEIPACKZETTEL HAS01.1-350-072-MN

Stck	Benennung	MN
1	LASCHE HMD/HMS01.1 ERDUNG	R911294924
		1:2
4	SCHEIBE 10,50X 20,00X 2,00 DIN 125 A	R911213277
		1:1
2	SCHIENE-VERBINDUNG HAS01.1-032-042	R911311751
		1:2
4	SCHIENE-VERBINDUNG HAS01.1-350-072 ISOL.	R911309954
		1:5
1	SCHILD-KLEBE UL-CSA WARNHINWEIS EN/FR 30	R911309089
		1:4
2	SCHR-LIN-M 3,0X 8,0-T-8.8-ISO7045-ZN-ML*	R911294165
		1:1
17	SCHR-LIN-M 6,0X25,0-K-8.8-ISO7045-ZN-Z41	R911276873
		1:1
4	SECHSKANTSCHRAUBE ISO4017-M10X30-8.8A1E	R913000050
		1:2

### BEIPACKZETTEL HAS01.1-350-072-MN

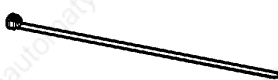
Stck	Benennung	MN
2	ENDSTUECK HAS01.1 SCHIENE-VERBINDUNG	R911311982
		1:2
4	FEDERRING DIN127-B10-FST &	R911213251
		1:1
5	KAB-BIND-D045-B4,8-C085-N220-TR-PA-*****	R911222614
		1:4

Datum	2004-02-23	Benennung
Name	Hirt	BEIPACKZETTEL HAS01.1-350-072-MN
Material-Nr.	R911306618	Zeich-Nr. 109-1253-4208-07
Datei	DB166280	Ers.durch ... AEM-Nr. 5-017509

Fig. 14-14: Accompanying note

Accessories in the Drive System Rexroth IndraDrive

Made in Germany  
109-1253-4812-05

**Rexroth  
Bosch Group**









## HAS01.1-350-NNN-MN

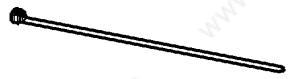

R911306632

4	SECHSKANTSCHRAUBE ISO4017-M10X30-8.8A1E	R913000050
15	SCHR-LIN-M 6,0X25,0-K-8.8-ISO7045-ZN-Z41	R911276873
2	SCHR-LIN-M 3,0X 8,0-T-8.8-ISO7045-ZN-ML*	R911294165
1	SCHILD-KLEBE UL-CSA WARNHINWEIS EN/FR 30	R911309089
4	SCHEIBE 10,50X 20,00X 2,00 DIN 125 A	R911213277
5	KAB-BIND-D045-B4,8-C085-N220-TR-PA-*****	R911222614
4	FEDERRING DIN127-B10-FST &	R911213251
2	ENDSTUECK HAS01.1 SCHIENE-VERBINDUNG	R911311982
Stck	Benennung	MN

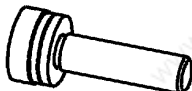
**BEIPACKZETTEL HAS01.1-350-NNN-MN**

Stck	Benennung	MN
2	ENDSTUECK HAS01.1 SCHIENE-VERBINDUNG	R911311982
		
		1:2
4	FEDERRING DIN127-B10-FST &	R911213251
		
		1:1
5	KAB-BIND-D045-B4,8-C085-N220-TR-PA-*****	R911222614
		
		1:4
4	SCHEIBE 10,50X 20,00X 2,00 DIN 125 A	R911213277
		
		1:1
1	SCHILD-KLEBE UL-CSA WARNHINWEIS EN/FR 30	R911309089
		
		1:4
2	SCHR-LIN-M 3,0X 8,0-T-8.8-ISO7045-ZN-ML*	R911294165
		
		1:1
15	SCHR-LIN-M 6,0X25,0-K-8.8-ISO7045-ZN-Z41	R911276873
		
		1:1
4	SECHSKANTSCHRAUBE ISO4017-M10X30-8.8A1E	R913000050
		
		1:2

<b>Datum</b>	2004-02-24	<b>Benennung</b>	BEIPACKZETTEL HAS01.1-350-NNN-MN		
<b>Name</b>	Hirt	<b>Material-Nr.</b>	R911306632	<b>Zeich-Nr.</b>	109-1253-4220-05
<b>Datei</b>	DB166325	<b>Ers.durch</b>	..	<b>AEM-Nr.</b>	5-017509

Fig.14-15: Accompanying note



Accessories in the Drive System Rexroth IndraDrive

Made in Germany  
109-1253-4827-00

**Rexroth  
Bosch Group**

## HAS01.1-065-072-CN

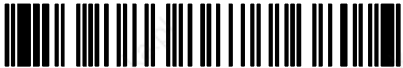

R911311807



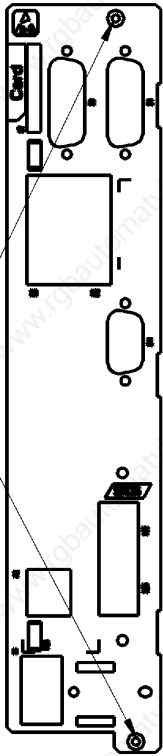

6	SCHR-LIN-M 6,0X25,0-K-8.8-ISO7045-ZN-Z41	R911276873
2	SCHR-LIN-M 3,0X 8,0-T-8.8-ISO7045-ZN-ML*	R911294165
1	SCHILD-KLEBE UL-CSA WARNHINWEIS EN/FR 30	R911309089
2	SCHIENE-VERBINDUNG HAS01.1-065-072 ISOL.	R911311806
5	KAB-BIND-D045-B4,8-C085-N220-TR-PA-*****	R911222614
Stck	Benennung	MNR



Einbauposition  
der Schraube  
M3x8

1:2

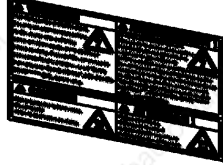
### BEIPACKZETTEL HAS01.1-065-072-CN

Stck	Benennung	MNR
5 DB140855		R911222614 1:4
2 DB187254		R911311806 1:2
1 DB115105		R911309089 2:5
2 DB-40060		R911294165 1:1
6 DB-51729		R911276873 1:2

Datum	2005-06-01	Benennung
Name	rainhirt	BEIPACKZETTEL HAS01.1-065-072-CN
Material-Nr.	R911311810	Zeich-Nr. 109-1253-4265-00
Datei	DB187295	Ers.durch .. AEM-Nr. 5-017033

Fig. 14-16: Accompanying note

Accessories in the Drive System Rexroth IndraDrive

Made in Germany  
109-1253-4828-00

**Rexroth  
Bosch Group**





## HAS01.1-105-072-CN

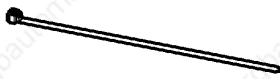

R911311808

8	SCHR-LIN-M 6,0x25,0-K-8.8-ISO7045-ZN-Z41	R911276873
2	SCHR-LIN-M 3,0x 8,0-T-8.8-ISO7045-ZN-ML*	R911294165
1	SCHILD-KLEBE UL-CSA WARNHINWEIS EN/FR 30	R911309089
2	SCHIENE-VERBINDUNG HAS01.1-105-072 ISOL.	R911311805
5	KAB-BIND-D045-B4,8-C085-N220-TR-PA-*****	R911222614
Stck	Benennung	MNR

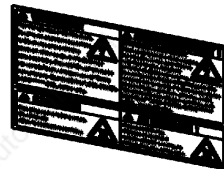
**BEIPACKZETTEL HAS01.1-105-072-CN**

Stck	Benennung	MNR
5	KAB-BIND-D045-B4,8-C085-N220-TR-PA-*****	R911222614
DBT-46855		1:4
2	SCHIENE-VERBINDUNG HAS01.1-105-072 ISOL.	R911311805
DBT67255		1:2
1	SCHILD-KLEBE UL-CSA WARNHINWEIS EN/FR 30	R911309089
DBT15705		2:5
2	SCHR-LIN-M 3,0x 8,0-T-8.8-ISO7045-ZN-ML*	R911294165
DB-10060		1:1
8	SCHR-LIN-M 6,0x25,0-K-8.8-ISO7045-ZN-Z41	R911276873
DB-51729		1:1

Einbauposition  
der Schraube  
M3x8

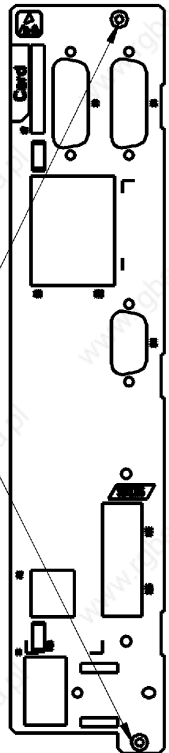

1:2

Datum	2005-06-01	Benennung
Name	rainhirt	BEIPACKZETTEL HAS01.1-105-072-CN
Material-Nr.	R911311812	Zeich-Nr. 109-1253-4266-00
Datei	DB187297	Ers.durch .. AEM-Nr. 5-017033

Fig.14-17: Accompanying note

Accessories in the Drive System Rexroth IndraDrive

Made in Germany  
109-1228-4812-02



## HAS01.1-065-NNN-CN



R911306007



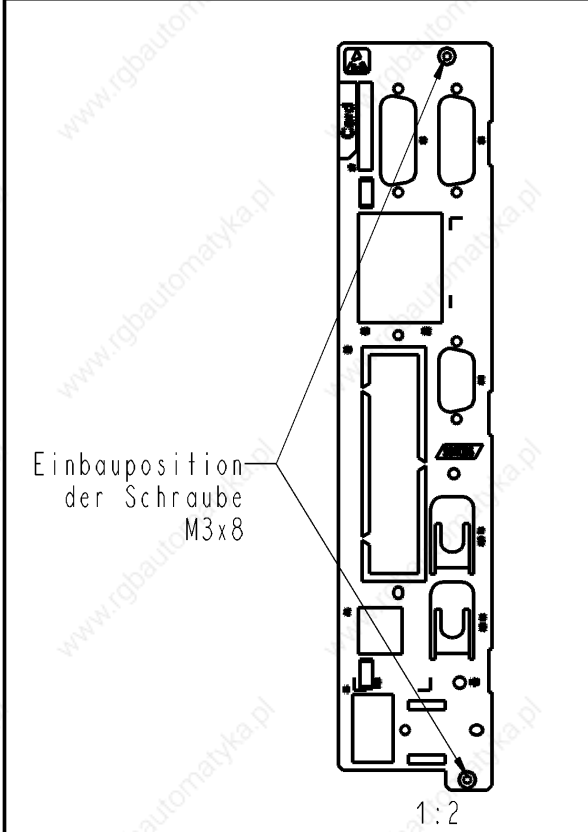

2	WERKZ-BETAETIGUNG STECK-FK RM3,50	R911295970
2	SCHR-LIN-M 6,0X25,0-K-8.8-ISO7045-ZN-Z41	R911276873
2	SCHR-LIN-M 3,0X 8,0-T-8.8-ISO7045-ZN-ML*	R911294165
1	SCHILD-KLEBE UL-CSA WARNHINWEIS EN/FR 30	R911309089
5	KAB-BIND-D045-B4,8-C085-N220-TR-PA-*****	R911222614
Stck	Benennung	MNR

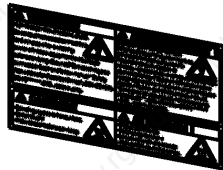

Einbauposition  
der Schraube  
M3x8

1:2

### BEIPACKZETTEL HAS01.1-065-NNN-CN

Stck	Benennung	MNR
5	KAB-BIND-D045-B4,8-C085-N220-TR-PA-*****	R911222614
DB146855		1:4
1	SCHILD-KLEBE UL-CSA WARNHINWEIS EN/FR 30	R911309089
DB175105		2:5
2	SCHR-LIN-M 3,0X 8,0-T-8.8-ISO7045-ZN-ML*	R911294165
DB_40060		1:1
2	SCHR-LIN-M 6,0X25,0-K-8.8-ISO7045-ZN-Z41	R911276873
DB_54729		1:2
2	WERKZ-BETAETIGUNG STECK-FK RM3,50	R911295970
DB144743		1:1

Datum	2004-01-29	Benennung	BEIPACKZETTEL HAS01.1-065-NNN-CN
Name	Hirt	Zeich-Nr.	109-1228-4230-03
Material-Nr.	R911306096	Ers.durch	..
Datei	DB165225	AEM-Nr.	5-010883

Fig. 14-18: Accompanying note

Accessories in the Drive System Rexroth IndraDrive

Made in Germany  
109-1229-4813-02







# HAS01.1-105-NNN-CN

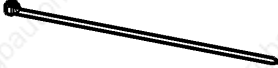

R911306008

2	WERKZ-BETAETIGUNG STECK-FK RM3,50	R911295970
4	SCHR-LIN-M 6,0X25,0-K-8.8-ISO7045-ZN-Z4I	R911276873
2	SCHR-LIN-M 3,0X 8,0-T-8.8-ISO7045-ZN-ML*	R911294165
1	SCHILD-KLEBE UL-CSA WARNHINWEIS EN/FR 30	R911309089
5	KAB-BIND-D045-B4,8-C085-N220-TR-PA-*****	R911222614
Stck	Benennung	MNR

### BEIPACKZETTEL HAS01.1-105-NNN-CN

Stck	Benennung	MNR
5	 1:4	R911222614
1	 2:5	R911309089
2	 1:1	R911294165
4	 1:2	R911276873
2	 1:1	R911295970

Einbauposition  
der Schraube  
M3x8

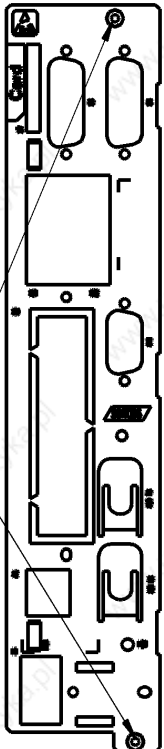

1:2

Datum	2004-01-29	Benennung	BEIPACKZETTEL HAS01.1-105-NNN-CN	
Name	Hirt	Material-Nr.	R911306098	Zeich-Nr.
			109-1229-4224-03	
Datei	DB165229	Ers.durch	..	AEM-Nr.
				5-010883

Fig.14-19: Accompanying note

Accessories in the Drive System Rexroth IndraDrive



<p>Made in Germany 109-1253-4813-04</p> <p style="text-align: right;"><b>Rexroth Bosch Group</b></p> <h2 style="text-align: center;">HAS01.1-125-072-CN</h2>  <p style="text-align: center;">R911306664</p> <table border="1" style="width: 100%; border-collapse: collapse; margin-top: 10px;"> <thead> <tr> <th style="width: 5%;">Stck</th> <th style="width: 85%;">Benennung</th> <th style="width: 10%;">MNR</th> </tr> </thead> <tbody> <tr> <td>15</td> <td>SCHR-LIN-M 6,0X25,0-K-8-8-ISO7045-ZN-Z41</td> <td>R911276873</td> </tr> <tr> <td>2</td> <td>SCHR-LIN-M 3,0X 8,0-T-8-8-ISO7045-ZN-ML*</td> <td>R911294165</td> </tr> <tr> <td>1</td> <td>SCHILD-KLEBE UL-CSA WARNHINWEIS EN/FR 30</td> <td>R911309089</td> </tr> <tr> <td>4</td> <td>SCHIENE-VERBINDUNG HAS01.1-125-072 ISOL.</td> <td>R911309948</td> </tr> <tr> <td>2</td> <td>SCHIENE-VERBINDUNG HAS01.1-032-042</td> <td>R911311751</td> </tr> <tr> <td>1</td> <td>LASCHE HMD/HMS01.1 ERDUNG</td> <td>R911294924</td> </tr> <tr> <td>5</td> <td>KAB-BIND-D045-B4,8-C085-N220-TR-PA-*****</td> <td>R911222614</td> </tr> <tr> <th>Stck</th> <th>Benennung</th> <th>MNR</th> </tr> </tbody> </table>	Stck	Benennung	MNR	15	SCHR-LIN-M 6,0X25,0-K-8-8-ISO7045-ZN-Z41	R911276873	2	SCHR-LIN-M 3,0X 8,0-T-8-8-ISO7045-ZN-ML*	R911294165	1	SCHILD-KLEBE UL-CSA WARNHINWEIS EN/FR 30	R911309089	4	SCHIENE-VERBINDUNG HAS01.1-125-072 ISOL.	R911309948	2	SCHIENE-VERBINDUNG HAS01.1-032-042	R911311751	1	LASCHE HMD/HMS01.1 ERDUNG	R911294924	5	KAB-BIND-D045-B4,8-C085-N220-TR-PA-*****	R911222614	Stck	Benennung	MNR	<p style="text-align: center;"><b>BEIPACKZETTEL HAS01.1-125-072-CN</b></p> <table border="1" style="width: 100%; border-collapse: collapse;"> <thead> <tr> <th style="width: 5%;">Stck</th> <th style="width: 85%;">Benennung</th> <th style="width: 10%;">MNR</th> </tr> </thead> <tbody> <tr> <td>5</td> <td>KAB-BIND-D045-B4,8-C085-N220-TR-PA-*****</td> <td>R911222614</td> </tr> <tr> <td>1</td> <td>LASCHE HMD/HMS01.1 ERDUNG</td> <td>R911294924</td> </tr> <tr> <td>2</td> <td>SCHIENE-VERBINDUNG HAS01.1-032-042</td> <td>R911311751</td> </tr> <tr> <td>4</td> <td>SCHIENE-VERBINDUNG HAS01.1-125-072 ISOL.</td> <td>R911309948</td> </tr> <tr> <td>1</td> <td>SCHILD-KLEBE UL-CSA WARNHINWEIS EN/FR 30</td> <td>R911309089</td> </tr> <tr> <td>2</td> <td>SCHR-LIN-M 3,0X 8,0-T-8-8-ISO7045-ZN-ML*</td> <td>R911294165</td> </tr> <tr> <td>15</td> <td>SCHR-LIN-M 6,0X25,0-K-8-8-ISO7045-ZN-Z41</td> <td>R911276873</td> </tr> </tbody> </table> <table border="1" style="width: 100%; border-collapse: collapse; margin-top: 10px;"> <tr> <td style="width: 15%;">Datum</td> <td style="width: 35%;">2004-02-26</td> <td style="width: 50%;">Benennung</td> </tr> <tr> <td>Name</td> <td>Hirt / Steven</td> <td>BEIPACKZETTEL HAS01.1-125-072-CN</td> </tr> <tr> <td>Material-Nr.</td> <td>R911306672</td> <td>Zeich-Nr. 109-1253-4223-05</td> </tr> <tr> <td>Datei</td> <td>DB166375</td> <td>Ers.durch .. AEM-Nr. 5-017509</td> </tr> </table>	Stck	Benennung	MNR	5	KAB-BIND-D045-B4,8-C085-N220-TR-PA-*****	R911222614	1	LASCHE HMD/HMS01.1 ERDUNG	R911294924	2	SCHIENE-VERBINDUNG HAS01.1-032-042	R911311751	4	SCHIENE-VERBINDUNG HAS01.1-125-072 ISOL.	R911309948	1	SCHILD-KLEBE UL-CSA WARNHINWEIS EN/FR 30	R911309089	2	SCHR-LIN-M 3,0X 8,0-T-8-8-ISO7045-ZN-ML*	R911294165	15	SCHR-LIN-M 6,0X25,0-K-8-8-ISO7045-ZN-Z41	R911276873	Datum	2004-02-26	Benennung	Name	Hirt / Steven	BEIPACKZETTEL HAS01.1-125-072-CN	Material-Nr.	R911306672	Zeich-Nr. 109-1253-4223-05	Datei	DB166375	Ers.durch .. AEM-Nr. 5-017509
Stck	Benennung	MNR																																																														
15	SCHR-LIN-M 6,0X25,0-K-8-8-ISO7045-ZN-Z41	R911276873																																																														
2	SCHR-LIN-M 3,0X 8,0-T-8-8-ISO7045-ZN-ML*	R911294165																																																														
1	SCHILD-KLEBE UL-CSA WARNHINWEIS EN/FR 30	R911309089																																																														
4	SCHIENE-VERBINDUNG HAS01.1-125-072 ISOL.	R911309948																																																														
2	SCHIENE-VERBINDUNG HAS01.1-032-042	R911311751																																																														
1	LASCHE HMD/HMS01.1 ERDUNG	R911294924																																																														
5	KAB-BIND-D045-B4,8-C085-N220-TR-PA-*****	R911222614																																																														
Stck	Benennung	MNR																																																														
Stck	Benennung	MNR																																																														
5	KAB-BIND-D045-B4,8-C085-N220-TR-PA-*****	R911222614																																																														
1	LASCHE HMD/HMS01.1 ERDUNG	R911294924																																																														
2	SCHIENE-VERBINDUNG HAS01.1-032-042	R911311751																																																														
4	SCHIENE-VERBINDUNG HAS01.1-125-072 ISOL.	R911309948																																																														
1	SCHILD-KLEBE UL-CSA WARNHINWEIS EN/FR 30	R911309089																																																														
2	SCHR-LIN-M 3,0X 8,0-T-8-8-ISO7045-ZN-ML*	R911294165																																																														
15	SCHR-LIN-M 6,0X25,0-K-8-8-ISO7045-ZN-Z41	R911276873																																																														
Datum	2004-02-26	Benennung																																																														
Name	Hirt / Steven	BEIPACKZETTEL HAS01.1-125-072-CN																																																														
Material-Nr.	R911306672	Zeich-Nr. 109-1253-4223-05																																																														
Datei	DB166375	Ers.durch .. AEM-Nr. 5-017509																																																														

Fig. 14-20: Accompanying note

Accessories in the Drive System Rexroth IndraDrive

Made in Germany  
109-1253-4814-01







# HAS01.1-125-NNN-CN

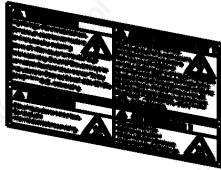

R911306665

2	WERKZ-BETAETIGUNG STECK-FK RM3,50	R911295970
11	SCHR-LIN-M 6,0X25,0-K-8.8-ISO7045-ZN-Z4I	R911276873
2	SCHR-LIN-M 3,0X 8,0-T-8.8-ISO7045-ZN-ML*	R911294165
1	SCHILD-KLEBE UL-CSA WARNHINWEIS EN/FR	R911299476
5	KAB-BIND-D045-B4,8-C085-N220-TR-PA-****	R911222614
Stck	Benennung	MNR

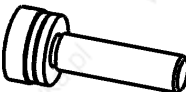
### BEIPACKZETTEL HAS01.1-125-NNN-CN

Stck	Benennung	MNR
5	KAB-BIND-D045-B4,8-C085-N220-TR-PA-****	R911222614
		
		1:4
1	SCHILD-KLEBE UL-CSA WARNHINWEIS EN/FR	R911299476
		
		2:5
2	SCHR-LIN-M 3,0X 8,0-T-8.8-ISO7045-ZN-ML*	R911294165
		
		1:1
11	SCHR-LIN-M 6,0X25,0-K-8.8-ISO7045-ZN-Z4I	R911276873
		
		1:1
2	WERKZ-BETAETIGUNG STECK-FK RM3,50	R911295970
		
		1:1

Einbauposition  
der Schraube  
M3x8

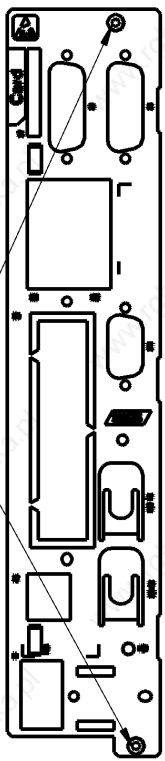

1:2

Datum	2004-02-26	Benennung
Name	Hirt / Slevén	BEIPACKZETTEL HAS01.1-125-NNN-CN
Material-Nr.	R911306674	Zeich-Nr. 109-1253-4224-01
Datei	DB166377	Ers.durch .. AEM-Nr. 5-07273

Fig.14-21: Accompanying note

Accessories in the Drive System Rexroth IndraDrive

<p>Made in Germany 109-1253-4815-04</p> <p style="text-align: right;"><b>Rexroth Bosch Group</b></p> <h2 style="text-align: center;">HAS01.1-225-072-CN</h2> <p style="text-align: center;">R911306666</p> <table border="1" style="width: 100%; border-collapse: collapse; margin-top: 10px;"> <thead> <tr> <th style="width: 5%;">Stck</th> <th style="width: 85%;">Benennung</th> <th style="width: 10%;">MNR</th> </tr> </thead> <tbody> <tr> <td>21</td> <td>SCHR-LIN-M 6,0X25,0-K-8.8-ISO7045-ZN-Z41</td> <td>R911276873</td> </tr> <tr> <td>2</td> <td>SCHR-LIN-M 3,0X 8,0-T-8.8-ISO7045-ZN-ML*</td> <td>R911294165</td> </tr> <tr> <td>1</td> <td>SCHILD-KLEBE UL-CSA WARNHINWEIS EN/FR 30</td> <td>R911309089</td> </tr> <tr> <td>4</td> <td>SCHIENE-VERBINDUNG HAS01.1-225-072 ISOL.</td> <td>R911309952</td> </tr> <tr> <td>2</td> <td>SCHIENE-VERBINDUNG HAS01.1-032-042</td> <td>R911311751</td> </tr> <tr> <td>1</td> <td>LASCHE HMD/HMS01.1 ERDUNG</td> <td>R911294924</td> </tr> <tr> <td>5</td> <td>KAB-BIND-D045-B4,8-C085-N220-TR-PA-*****</td> <td>R911222614</td> </tr> <tr> <th>Stck</th> <th>Benennung</th> <th>MNR</th> </tr> </tbody> </table>	Stck	Benennung	MNR	21	SCHR-LIN-M 6,0X25,0-K-8.8-ISO7045-ZN-Z41	R911276873	2	SCHR-LIN-M 3,0X 8,0-T-8.8-ISO7045-ZN-ML*	R911294165	1	SCHILD-KLEBE UL-CSA WARNHINWEIS EN/FR 30	R911309089	4	SCHIENE-VERBINDUNG HAS01.1-225-072 ISOL.	R911309952	2	SCHIENE-VERBINDUNG HAS01.1-032-042	R911311751	1	LASCHE HMD/HMS01.1 ERDUNG	R911294924	5	KAB-BIND-D045-B4,8-C085-N220-TR-PA-*****	R911222614	Stck	Benennung	MNR	<p style="text-align: center;"><b>BEIPACKZETTEL HAS01.1-225-072-CN</b></p> <table border="1" style="width: 100%; border-collapse: collapse;"> <thead> <tr> <th style="width: 5%;">Stck</th> <th style="width: 85%;">Benennung</th> <th style="width: 10%;">MNR</th> </tr> </thead> <tbody> <tr> <td>5</td> <td>KAB-BIND-D045-B4,8-C085-N220-TR-PA-*****</td> <td>R911222614</td> </tr> <tr> <td>1</td> <td>LASCHE HMD/HMS01.1 ERDUNG</td> <td>R911294924</td> </tr> <tr> <td>2</td> <td>SCHIENE-VERBINDUNG HAS01.1-032-042</td> <td>R911311751</td> </tr> <tr> <td>4</td> <td>SCHIENE-VERBINDUNG HAS01.1-225-072 ISOL.</td> <td>R911309952</td> </tr> <tr> <td>1</td> <td>SCHILD-KLEBE UL-CSA WARNHINWEIS EN/FR 30</td> <td>R911309089</td> </tr> <tr> <td>2</td> <td>SCHR-LIN-M 3,0X 8,0-T-8.8-ISO7045-ZN-ML*</td> <td>R911294165</td> </tr> <tr> <td>21</td> <td>SCHR-LIN-M 6,0X25,0-K-8.8-ISO7045-ZN-Z41</td> <td>R911276873</td> </tr> </tbody> </table> <table border="1" style="width: 100%; border-collapse: collapse; margin-top: 10px;"> <tr> <td style="width: 15%;">Datum</td> <td style="width: 35%;">2004-02-26</td> <td style="width: 50%;">Benennung</td> </tr> <tr> <td>Name</td> <td>Hirt / Steven</td> <td>BEIPACKZETTEL HAS01.1-225-072-CN</td> </tr> <tr> <td>Material-Nr.</td> <td>R911306675</td> <td>Zeich-Nr. 109-1253-4225-05</td> </tr> <tr> <td>Datei</td> <td>DB166379</td> <td>Ers.durch ... AEM-Nr. 5-017509</td> </tr> </table>	Stck	Benennung	MNR	5	KAB-BIND-D045-B4,8-C085-N220-TR-PA-*****	R911222614	1	LASCHE HMD/HMS01.1 ERDUNG	R911294924	2	SCHIENE-VERBINDUNG HAS01.1-032-042	R911311751	4	SCHIENE-VERBINDUNG HAS01.1-225-072 ISOL.	R911309952	1	SCHILD-KLEBE UL-CSA WARNHINWEIS EN/FR 30	R911309089	2	SCHR-LIN-M 3,0X 8,0-T-8.8-ISO7045-ZN-ML*	R911294165	21	SCHR-LIN-M 6,0X25,0-K-8.8-ISO7045-ZN-Z41	R911276873	Datum	2004-02-26	Benennung	Name	Hirt / Steven	BEIPACKZETTEL HAS01.1-225-072-CN	Material-Nr.	R911306675	Zeich-Nr. 109-1253-4225-05	Datei	DB166379	Ers.durch ... AEM-Nr. 5-017509
Stck	Benennung	MNR																																																														
21	SCHR-LIN-M 6,0X25,0-K-8.8-ISO7045-ZN-Z41	R911276873																																																														
2	SCHR-LIN-M 3,0X 8,0-T-8.8-ISO7045-ZN-ML*	R911294165																																																														
1	SCHILD-KLEBE UL-CSA WARNHINWEIS EN/FR 30	R911309089																																																														
4	SCHIENE-VERBINDUNG HAS01.1-225-072 ISOL.	R911309952																																																														
2	SCHIENE-VERBINDUNG HAS01.1-032-042	R911311751																																																														
1	LASCHE HMD/HMS01.1 ERDUNG	R911294924																																																														
5	KAB-BIND-D045-B4,8-C085-N220-TR-PA-*****	R911222614																																																														
Stck	Benennung	MNR																																																														
Stck	Benennung	MNR																																																														
5	KAB-BIND-D045-B4,8-C085-N220-TR-PA-*****	R911222614																																																														
1	LASCHE HMD/HMS01.1 ERDUNG	R911294924																																																														
2	SCHIENE-VERBINDUNG HAS01.1-032-042	R911311751																																																														
4	SCHIENE-VERBINDUNG HAS01.1-225-072 ISOL.	R911309952																																																														
1	SCHILD-KLEBE UL-CSA WARNHINWEIS EN/FR 30	R911309089																																																														
2	SCHR-LIN-M 3,0X 8,0-T-8.8-ISO7045-ZN-ML*	R911294165																																																														
21	SCHR-LIN-M 6,0X25,0-K-8.8-ISO7045-ZN-Z41	R911276873																																																														
Datum	2004-02-26	Benennung																																																														
Name	Hirt / Steven	BEIPACKZETTEL HAS01.1-225-072-CN																																																														
Material-Nr.	R911306675	Zeich-Nr. 109-1253-4225-05																																																														
Datei	DB166379	Ers.durch ... AEM-Nr. 5-017509																																																														

Fig. 14-22: Accompanying note



Accessories in the Drive System Rexroth IndraDrive

Made in Germany  
109-1253-4816-01







# HAS01.1-225-NNN-CN

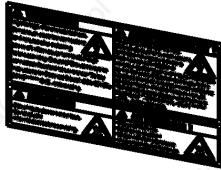

R911306667

2	WERKZ-BETAETIGUNG STECK-FK RM3,50	R911295970
17	SCHR-LIN-M 6,0X25,0-K-8.8-ISO7045-ZN-Z4I	R911276873
2	SCHR-LIN-M 3,0X 8,0-T-8.8-ISO7045-ZN-ML*	R911294165
1	SCHILD-KLEBE UL-CSA WARNHINWEIS EN/FR	R911299476
5	KAB-BIND-D045-B4,8-C085-N220-TR-PA-****	R911222614
<b>Stck</b>	<b>Benennung</b>	<b>MNR</b>

### BEIPACKZETTEL HAS01.1-225-NNN-CN

Stck	Benennung	MNR
5	 KAB-BIND-D045-B4,8-C085-N220-TR-PA-****	R911222614  1:4
1	 SCHILD-KLEBE UL-CSA WARNHINWEIS EN/FR	R911299476  2:5
2	 SCHR-LIN-M 3,0X 8,0-T-8.8-ISO7045-ZN-ML*	R911294165  1:1
17	 SCHR-LIN-M 6,0X25,0-K-8.8-ISO7045-ZN-Z4I	R911276873  1:1
2	 WERKZ-BETAETIGUNG STECK-FK RM3,50	R911295970  1:1

Einbauposition  
der Schraube  
M3x8

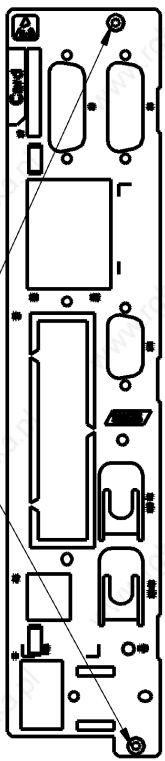

1:2

Datum	2004-02-26	Benennung	BEIPACKZETTEL HAS01.1-225-NNN-CN	
Name	Hirt / Slevén	Material-Nr.	R911306667	Zeich-Nr.
Material-Nr.	R911306667	Ers.durch	109-1253-4226-01	AEM-Nr.
Datei	DB166381	Ers.durch	..	AEM-Nr.
				5-07273

Fig.14-23: Accompanying note

Accessories in the Drive System Rexroth IndraDrive

Made in Germany  
109-1253-4817-06

**Rexroth**  
**Bosch Group**

## HAS01.1-350-072-CN

R911306668

1	SECHSKANTSCHRAUBE ISO4017-M8X25-8.8 &	R911292421
6	SECHSKANTSCHRAUBE ISO4017-M10X30-8.8A1E	R913000050
15	SCHR-LIN-M 6,0X25,0-K-8.8-ISO7045-ZN-Z41	R911276873
2	SCHR-LIN-M 3,0X 8,0-T-8.8-ISO7045-ZN-ML*	R911294165
1	SCHILD-KLEBE UL-CSA WARNHINWEIS EN/FR 30	R911309089
4	SCHIENE-VERBINDUNG HAS01.1-350-072 ISOL.	R911309954
2	SCHIENE-VERBINDUNG HAS01.1-032-042	R911311751
6	SCHEIBE 10,50X 20,00X 2,00 DIN 125 A	R911213277
1	LASCHE HMD/HMS01.1 ERDUNG	R911294924
1	LASCHE HCS03.1E-W0210 ERDUNG	R911025419
5	KAB-BIND-D045-B4,8-C085-N220-TR-PA-*****	R911222614
6	FEDERRING DIN127-B10-FST &	R911213251
2	ENDSTUECK HAS01.1 SCHIENE-VERBINDUNG	R911311982
<b>Stck</b>	<b>Benennung</b>	<b>MN</b>

**BEIPACKZETTEL HAS01.1-350-072-CN**

Stck	Benennung	MN
1	LASCHE HMD/HMS01.1 ERDUNG	R911294924
6	SCHEIBE 10,50X 20,00X 2,00 DIN 125 A	R911213277
2	SCHIENE-VERBINDUNG HAS01.1-032-042	R911311751
4	SCHIENE-VERBINDUNG HAS01.1-350-072 ISOL.	R911309954
1	SCHILD-KLEBE UL-CSA WARNHINWEIS EN/FR 30	R911309089
2	SCHR-LIN-M 3,0X 8,0-T-8.8-ISO7045-ZN-ML*	R911294165
15	SCHR-LIN-M 6,0X25,0-K-8.8-ISO7045-ZN-Z41	R911276873
6	SECHSKANTSCHRAUBE ISO4017-M10X30-8.8A1E	R913000050
5	KAB-BIND-D045-B4,8-C085-N220-TR-PA-*****	R911222614
6	FEDERRING DIN127-B10-FST &	R911213251
2	ENDSTUECK HAS01.1 SCHIENE-VERBINDUNG	R911311982

**BEIPACKZETTEL HAS01.1-350-072-CN**

Stck	Benennung	MN
2	ENDSTUECK HAS01.1 SCHIENE-VERBINDUNG	R911311982
6	FEDERRING DIN127-B10-FST &	R911213251
5	KAB-BIND-D045-B4,8-C085-N220-TR-PA-*****	R911222614
1	LASCHE HCS03.1E-W0210 ERDUNG	R911025419

<b>Datum</b>	2004-02-28	<b>Benennung</b>	BEIPACKZETTEL HAS01.1-350-072-CN
<b>Name</b>	Hirt / Steven	<b>Material-Nr.</b>	R911306668
<b>Material-Nr.</b>	R911306668	<b>Zeich-Nr.</b>	109-1253-4227-07
<b>Datei</b>	DB166387	<b>Ers.durch</b>	...
		<b>AEM-Nr.</b>	5-017509

Fig. 14-24: Accompanying note

Accessories in the Drive System Rexroth IndraDrive

Made in Germany  
109-1253-4818-06

**Rexroth  
Bosch Group**

## HAS01.1-350-NNN-CN



R911306669

Stck	Benennung	MN
1	SECHSKANTSCHRAUBE ISO4017-M8X25-8.8 &	R911292421
6	SECHSKANTSCHRAUBE ISO4017-M10X30-8.8A1E	R913000050
13	SCHR-LIN-M 6,0X25,0-K-8.8-ISO7045-ZN-Z41	R911216873
2	SCHR-LIN-M 3,0X 8,0-T-8.8-ISO7045-ZN-ML*	R911294165
1	SCHILD-KLEBE UL-CSA WARNHINWEIS EN/FR 30	R911309089
6	SCHEIBE 10,50X 20,00X 2,00 DIN 125 A	R911213277
1	LASCHE HCS03.1E-W0210 ERDUNG	R911025419
6	KAB-BIND-D045-B4,8-C085-N220-TR-PA-*****	R911222614
5	FEDERRING DIN127-B10-FST &	R911213251
2	ENDSTUECK HAS01.1 SCHIENE-VERBINDUNG	R911311982

### BEIPACKZETTEL HAS01.1-350-NNN-CN

Stck	Benennung	MN
1	LASCHE HCS03.1E-W0210 ERDUNG	R911025419
6	SCHEIBE 10,50X 20,00X 2,00 DIN 125 A	R911213277
1	SCHILD-KLEBE UL-CSA WARNHINWEIS EN/FR 30	R911309089
2	SCHR-LIN-M 3,0X 8,0-T-8.8-ISO7045-ZN-ML*	R911294165
13	SCHR-LIN-M 6,0X25,0-K-8.8-ISO7045-ZN-Z41	R911216873
6	SECHSKANTSCHRAUBE ISO4017-M10X30-8.8A1E	R913000050
1	SECHSKANTSCHRAUBE ISO4017-M8X25-8.8 &	R911292421

### BEIPACKZETTEL HAS01.1-350-NNN-CN

Stck	Benennung	MN
2	ENDSTUECK HAS01.1 SCHIENE-VERBINDUNG	R911311982
6	FEDERRING DIN127-B10-FST &	R911213251
5	KAB-BIND-D045-B4,8-C085-N220-TR-PA-*****	R911222614

### BEIPACKZETTEL HAS01.1-350-NNN-CN

Stck	Benennung	MN
2	ENDSTUECK HAS01.1 SCHIENE-VERBINDUNG	R911311982
6	FEDERRING DIN127-B10-FST &	R911213251
5	KAB-BIND-D045-B4,8-C085-N220-TR-PA-*****	R911222614

<b>Datum</b>	2004-02-26	<b>Benennung</b>	BEIPACKZETTEL HAS01.1-350-NNN-CN	
<b>Name</b>	Hirt / Slevén	<b>Material-Nr.</b>	R911306679	<b>Zeich-Nr.</b> 109-1253-4228-07
<b>Datei</b>	DB166390	<b>Ers.durch</b>	..	<b>AEM-Nr.</b> 5-017509

Fig.14-25: Accompanying note

Accessories in the Drive System Rexroth IndraDrive

Made in Germany  
109-1253-4849-00

**Rexroth**  
**Bosch Group**







## HAS01.1-350-NNN-CA



R911315683

9	SECHSKANTSCHRAUBE ISO4017-M10X30-8.8A1E	R913000050
9	SECHSKANTMUTTER ISO4032-M10-8-E0P	R911213275
16	SCHR-LIN-M 6,0X25,0-K-8.8-ISO7045-ZN-Z41	R911276873
2	SCHR-LIN-M 3,0X 8,0-T-8.8-ISO7045-ZN-ML*	R911294165
1	SCHILD-KLEBE UL-CSA WARNHINWEIS EN/FR 30	R911309089
9	SCHLEIBE 10,50X 20,00X 2,00 DIN 125 A	R911213277
5	KAB-BIND-D045-B4,8-C085-N220-TR-PA-*****	R911222614
9	FEDERRING DIN127-B10-FST &	R911213251
2	ENDSTUECK HAS01.1 SCHIENE-VERBINDUNG	R911311982
Stck	Benennung	MN

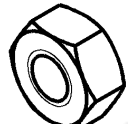
**BEIPACKZETTEL HAS01.1-350-NNN-CA**

Stck	Benennung	MN
DB-48243	9 SCHEIBE 10,50X 20,00X 2,00 DIN 125 A	R911213277 1:1 
DB175105	1 SCHILD-KLEBE UL-CSA WARNHINWEIS EN/FR 30	R911309089 1:4 
DB-40060	2 SCHR-LIN-M 3,0X 8,0-T-8.8-ISO7045-ZN-ML*	R911294165 2:1 
DB-54729	16 SCHR-LIN-M 6,0X25,0-K-8.8-ISO7045-ZN-Z41	R911276873 1:1 
DB-39818	9 SECHSKANTMUTTER ISO4032-M10-8-E0P	R911213275 1:1 
DB115916	9 SECHSKANTSCHRAUBE ISO4017-M10X30-8.8A1E	R913000050 1:2 

Datum	2006-01-17	Benennung
Name	sonjrazz	BEIPACKZETTEL HAS01.1-350-NNN-CA
Material-Nr.	R911315811	Zeich-Nr. 109-1253-4283-00
Datei	DB195173	Ers.durch .. AEM-Nr. ...

BEIPACKZETTEL HAS01.1-350-NNN-CA		
Stck	Benennung	MN
DB181131	2 ENDSTUECK HAS01.1 SCHIENE-VERBINDUNG	R911311982 1:2 
DB113025	9 FEDERRING DIN127-B10-FST &	R911213251 1:1 
DB148855	5 KAB-BIND-D045-B4,8-C085-N220-TR-PA-*****	R911222614 1:4 

Fig. 14-26: Accompanying note

Accessories in the Drive System Rexroth IndraDrive

## 14.1.6 Mounting the Parts "Bar" and "End Piece" of the Accessories HAS01

The parts "bar" and "end piece" increase the current carrying capacity of the DC bus connections by reducing the involved contact resistances.

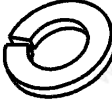
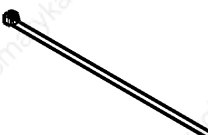
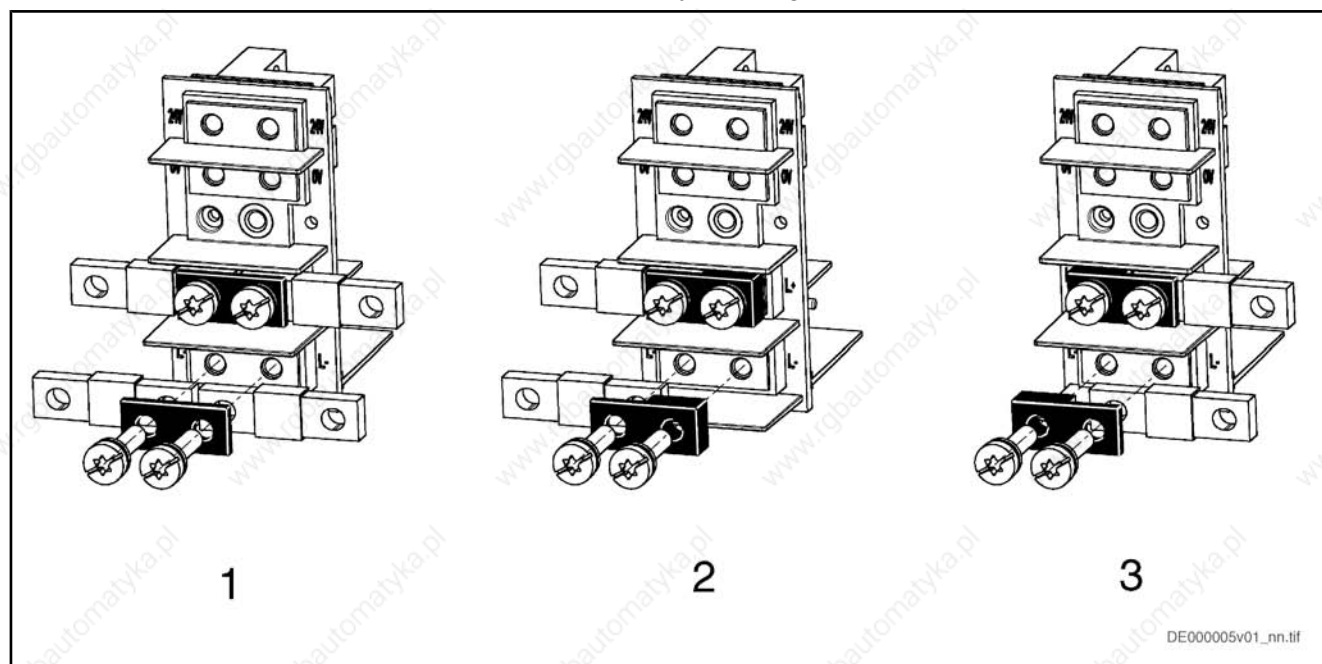

- 1 bar  
2 end piece (right end)  
3 end piece (left end)

Fig. 14-27: Mounting bar and end piece of HAS01

- **Ad 1:** Use the bars (-042) contained in all HAS01.1-\*\*\*-072-\*\* as shown in the figure at L+ and L-.
- **Ad 2 and 3:** Use the end pieces contained in all HAS01.1-350-\*\*\*-\*\* and HAS01.1-200-\*\*\*-\*\* at the right and left ends of the DC bus connections in the drive system.

## 14.2 HAS02 Shield Connection

### 14.2.1 General Information

Accessories for appropriate connection of the motor cable to the drive controller, especially the shield connection of the motor cable.

There are appropriate HAS02 accessories for the different drive controllers.

## 14.2.2 Type Code

Abbrev. Column	1	2	3	4	5	6	7	8	9	0	1	2	3	4	5	6	7	8	9	0	1	2	3	4	5	6	7	8	9	0	1	2	3	4	5	6	7	8	9	0					
Example:	H	A	S	0	2	.	1	-	0	0	1	-	N	N	N	-	N	N																											

1. **Product**

1.1 Accessories  
IndraDrive ... = HAS

2. **Line**

2.1 Shield connection. ... = 02

3. **Design**

3.1 1 ..... = 1

4. **Device assignment**

4.1 HMS01.1N-W0020 ..... = 001

4.2 HMS01.1N-W0036 ..... = 001

4.3 HMS01.1N-W0054 ..... = 002

4.4 HMS01.1N-W0070 ..... = 002

4.5 HMD01.1N-W0020 ..... = 002

4.6 HMD01.1N-W0036 ..... = 002

4.7 HCS02.1E-W0012 ..... = 002

4.8 HCS02.1E-W0028 ..... = 002

4.9 HCS02.1E-W0054 ..... = 002

4.10 HCS02.1E-W0070 ..... = 002

4.11 HMS01.1N-W0150 ..... = 003

4.12 HMS01.1N-W0210 ..... = 003

4.13 HCS03.1E-W0070 ..... = 004

4.14 HCS03.1E-W0100 ..... = 005

4.15 HCS03.1E-W0150 ..... = 005

4.16 HNK01.1A-A075-E0050 ..... = 006

4.17 HNK01.1A-A075-E0080 ..... = 007

4.18 HNK01.1A-A075-E0106 ..... = 007

4.19 HCS03.1E-W0210 ..... = 008

4.20 HNK01.1A-A075-E0146 ..... = 009

4.21 HMS02.1N-W0028 ..... = 010

4.22 HMS02.1N-W0054 ..... = 011

4.23 HCS04.1E-X0500 ..... = 012

5. **Other feature**

5.1 none ..... = NNN

6. **Other design**

6.1 none ..... = NN

DT000004v01\_en.fh

*Fig. 14-28: Type code HAS02.1*

## 14.2.3 Usage

The HAS02 accessories are used for

- strain relief of the motor cable
- connecting the shield of the motor cable to the drive controller

## 14.2.4 Assignment of Accessory HAS02

See section "Type Code (Device assignment)"

Accessories in the Drive System Rexroth IndraDrive

## 14.2.5 Scope of Supply

For the scope of supply and the components of HAS02, see the corresponding accompanying notes.



Accessories in the Drive System Rexroth IndraDrive

Made in Germany  
109-1214-4805-02







## HAS02.1-001-NNN-NN



R911306330

2	SCHR-LIN-M 6,0X12,0-K-8-8-ISO7045-ZN-Z41	R911252551
1	SCHELLE-SCHL-S023*035*B12-ZN-SW7*S-3017	R911274472
1	SCHELLE-SCHL-S012*022-B12-ZN-SW7*S-3017	R911274471
1	HALTERUNG HMS01.1 KABELD. 12-30	R911306336
1	BLECH HCS02.1 KABELBEFESTIGUNG	R911305851
Stck	Benennung	MN

BEIPACKZETTEL HAS02.1-001-NNN-NN		
Stck	Benennung	MN
DB163070	1 BLECH HCS02.1 KABELBEFESTIGUNG	R911305851
		1:5
DB164826	1 HALTERUNG HMS01.1 KABELD. 12-30	R911306336
		7:20
DB-46879	1 SCHELLE-SCHL-S012*022-B12-ZN-SW7*S-3017	R911274471
		1:2
DB-46888	1 SCHELLE-SCHL-S023*035*B12-ZN-SW7*S-3017	R911274472
		1:2
DB-38705	2 SCHR-LIN-M 6,0X12,0-K-8-8-ISO7045-ZN-Z41	R911252551
		1:1

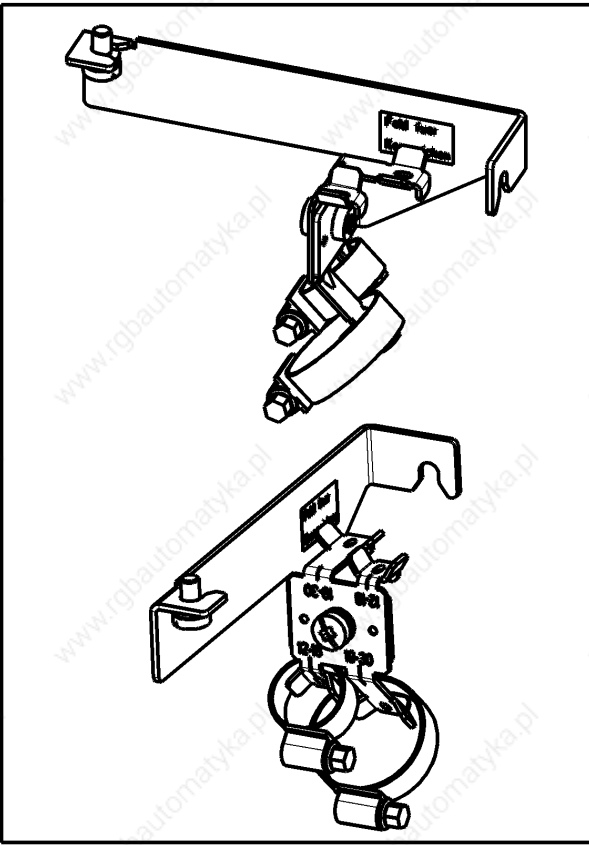

Datum	2004-02-03	Benennung	BEIPACKZETTEL HAS02.1-001-NNN-NN
Name	Hirt	Material-Nr.	R911306332
		Zeich-Nr.	109-1214-4213-02
Datei	DB165406	Ers.durch	...
		AEM-Nr.	5-07273

Fig. 14-29: Accompanying note

Accessories in the Drive System Rexroth IndraDrive

Made in Germany  
109-1228-4815-02





# HAS02.1-002-NNN-NN



R911306106

2	SCHR-LIN-M 6,0X12,0-K-8.8-ISO7045-ZN-Z41	R911252551
2	SCHELLE-SCHL-S012*022-B12-ZN-SW7*S-3017	R911274471
1	HALTERUNG HCS02.1 KABELD. 12-18	R911305852
1	BLECH HCS02.1 KABELBEFESTIGUNG	R911305851
Stck	Benennung	MN

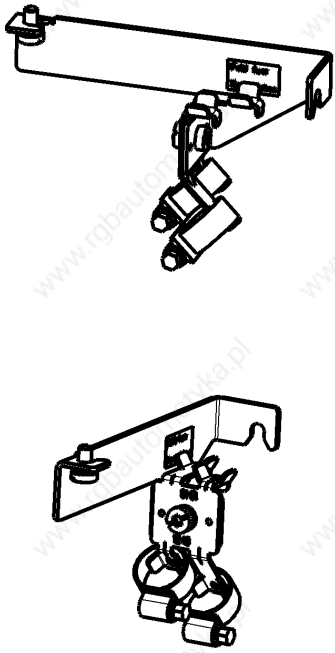
### BEIPACKZETTEL HAS02.1-002-NNN-NN

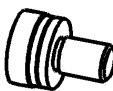
Stck	Benennung	MN
DB163070	 BLECH HCS02.1 KABELBEFESTIGUNG	R911305851  1:5
DB163246	 HALTERUNG HCS02.1 KABELD. 12-18	R911305852  7:20
DB-46879	 SCHELLE-SCHL-S012*022-B12-ZN-SW7*S-3017	R911274471  1:2
DB-38405	 SCHR-LIN-M 6,0X12,0-K-8.8-ISO7045-ZN-Z41	R911252551  1:1

Datum	2004-01-30	Benennung
Name	Born	BEIPACKZETTEL HAS02.1-002-NNN-NN
Material-Nr.	R911306107	Zeich-Nr. 109-1228-4231-02
Datei	DB165311	Ers.durch .. AEM-Nr. 5-07273

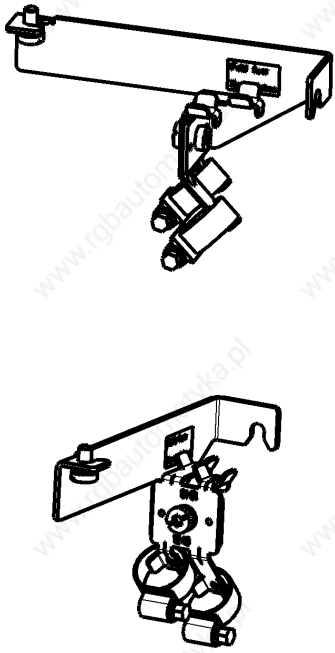



Fig.14-30: Accompanying note

Accessories in the Drive System Rexroth IndraDrive

Made in Germany  
109-1217-4816-02



## HAS02.1-003-NNN-NN





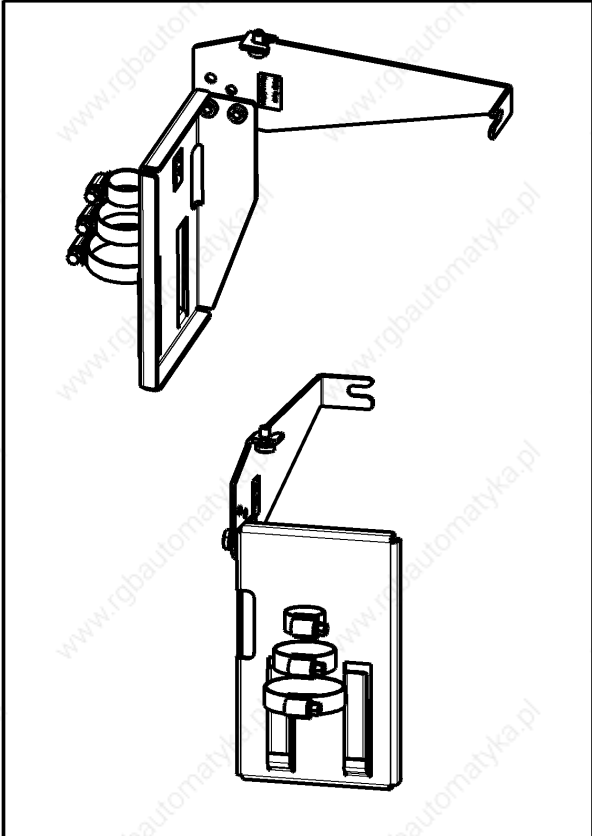

R911306331

1	WINKEL HMS01.1-W0210 ABSCHIRMANSCHLUSS	R911305950
3	SCHR-LIN-M 6,0X12,0-K-8.8-ISO7045-ZN-Z41	R911252551
1	SHELLE-SCHL-S032*050-B12-ZN-SW7*S-3017	R911296565
1	SHELLE-SCHL-S023*035*B12-ZN-SW7*S-3017	R911274472
1	SHELLE-SCHL-S012*022-B12-ZN-SW7*S-3017	R911274471
1	BLECH HMS01.1-W0210 ABSCHIRMANSCHLUSS	R911305940
<b>Stck</b>	<b>Benennung</b>	<b>MN</b>

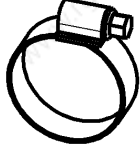

### BEIPACKZETTEL HAS02.1-003-NNN-NN

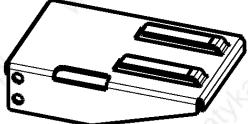
Stck	Benennung	MN
1	BLECH HMS01.1-W0210 ABSCHIRMANSCHLUSS	R911305940
DB164075		1:4
1	SHELLE-SCHL-S012*022-B12-ZN-SW7*S-3017	R911274471
DB_46879		1:2
1	SHELLE-SCHL-S023*035*B12-ZN-SW7*S-3017	R911274472
DB_46868		1:2
1	SHELLE-SCHL-S032*050-B12-ZN-SW7*S-3017	R911296565
DB148043		2:5
3	SCHR-LIN-M 6,0X12,0-K-8.8-ISO7045-ZN-Z41	R911252551
DB_38405		1:1
1	WINKEL HMS01.1-W0210 ABSCHIRMANSCHLUSS	R911305950
DB161163		1:5

Datum	2004-02-03	Benennung	BEIPACKZETTEL HAS02.1-003-NNN-NN
Name	Koblinger	Material-Nr.	R911306333
		Zeich-Nr.	109-1217-4262-02
Datei	DB164151	Ers.durch	...
		AEM-Nr.	5-07273

Fig.14-31: Accompanying note

Accessories in the Drive System Rexroth IndraDrive

Made in Germany  
109-1253-4819-01







## HAS02.1-004-NNN-NN

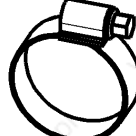

R911306720

I	SCHR-LIN-M 6,0X12,0-K-8.8-ISO7045-ZN-Z41	R911252551
I	SCHIRMWINKEL	R911024542
I	SHELLE-SCHL-S023*035*B12-ZN-SW7*S-3017	R911274472
I	SHELLE-SCHL-S012*022-B12-ZN-SW7*S-3017	R911274471
I	HALTERUNG HMS01.1 KABELD. 12-35	R911296081
Stck	Benennung	MN

BEIPACKZETTEL HAS02.1-004-NNN-NN		
Stck	Benennung	MN
DB145411	1 HALTERUNG HMS01.1 KABELD. 12-35 	R911296081 7:20
DB_16879	1 SCHELLE-SCHL-S012*022-B12-ZN-SW7*S-3017 	R911274471 1:2
DB_46868	1 SCHELLE-SCHL-S023*035*B12-ZN-SW7*S-3017 	R911274472 1:2
DB165569	1 SCHIRMWINKEL 	R911024542 1:5
DB_38705	1 SCHR-LIN-M 6,0X12,0-K-8.8-ISO7045-ZN-Z41 	R911252551 1:1

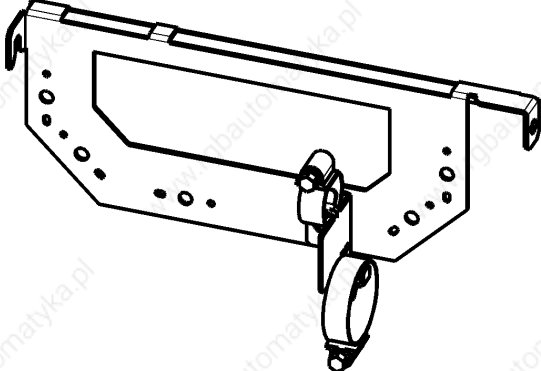

Datum	2004-03-02	Benennung	
Name	Hirt / Slevén	BEIPACKZETTEL HAS02.1-004-NNN-NN	
Material-Nr.	R911306724	Zeich-Nr.	109-1253-4229-01
Datei	DB168622	Ers.durch	.. AEM-Nr. 5-07273

Fig.14-32: Accompanying note

Accessories in the Drive System Rexroth IndraDrive

Made in Germany  
109-1253-4820-01







## HAS02.1-005-NNN-NN

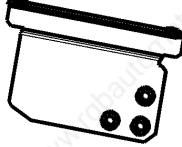

R911306721

1	WINKEL HMS01.1-W0150 ABSCHIRMANSCHLUSS	R911296068
4	SCHR-LIN-M 6,0X12,0-K-8.8-ISO7045-ZN-Z41	R911252551
1	SHELLE-SCHL-S032*050-B12-ZN-SW7*S-3017	R911296565
2	SHELLE-SCHL-S023*035*B12-ZN-SW7*S-3017	R911274472
1	ABSCHIRMANSCHLUSS	R911024379
Stck	Benennung	MN

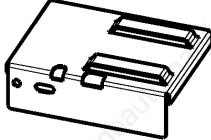
BEIPACKZETTEL HAS02.1-005-NNN-NN		
Stck	Benennung	MN
DB166511	1 ABSCHIRMANSCHLUSS 	R911024379 1:4
DB_46868	2 SCHELLE-SCHL-S023*035*B12-ZN-SW7*S-3017 	R911274472 1:2
DB148043	1 SCHELLE-SCHL-S032*050-B12-ZN-SW7*S-3017 	R911296565 7:20
DB_38405	4 SCHR-LIN-M 6,0X12,0-K-8.8-ISO7045-ZN-Z41 	R911252551 1:1
DB144663	1 WINKEL HMS01.1-W0150 ABSCHIRMANSCHLUSS 	R911296068 1:5

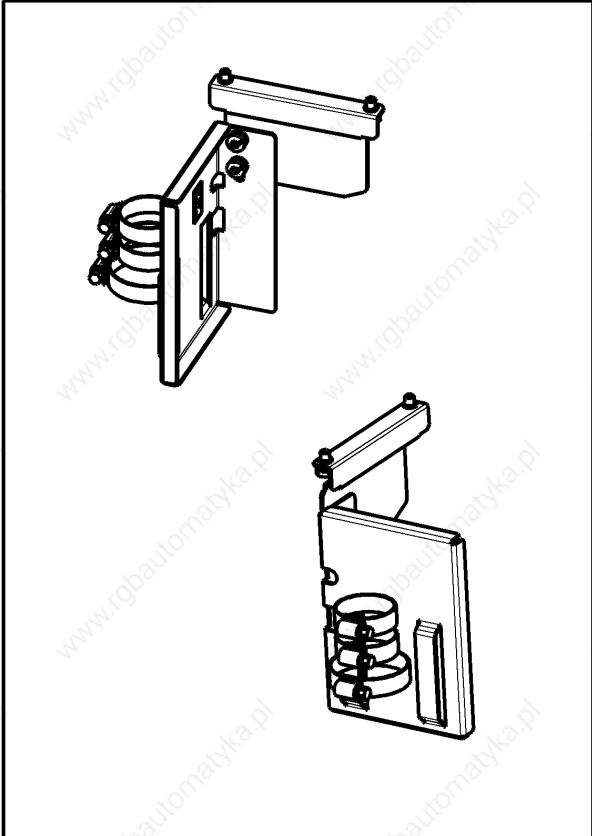

Datum	2004-03-02	Benennung	BEIPACKZETTEL HAS02.1-005-NNN-NN	
Name	Hirt / Steven	Material-Nr.	R911306725	Zeich-Nr. 109-1253-4230-01
Datei	DB166623	Ers.durch	..	AEM-Nr. 5-07273

Fig. 14-33: Accompanying note

Accessories in the Drive System Rexroth IndraDrive

Made in Germany  
109-1253-4821-01









## HAS02.1-006-NNN-NN

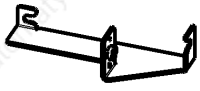

R911306722

1	SCHR-LIN-M 6,0X12,0-K-8.8-ISO7045-ZN-Z41	R911252551
1	SCHELLE-SCHL-S023*035*B12-ZN-SW7*S-3017	R911274472
1	SCHELLE-SCHL-S012*022-B12-ZN-SW7*S-3017	R911274471
2	MUTTER-KOM-M 5,0-D10-H05,80 A2-B	R911210162
1	HALTERUNG HMS01.1 KABELD. 12-30	R911306336
1	BLECH HCS02.1 KABELBEFESTIGUNG	R911305851
<b>Stck</b>	<b>Benennung</b>	<b>MN</b>

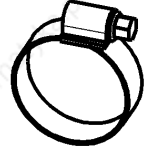
### BEIPACKZETTEL HAS02.1-006-NNN-NN

Stck	Benennung	MN
DB163070	 BLECH HCS02.1 KABELBEFESTIGUNG	R911305851 1:5
DB164826	 HALTERUNG HMS01.1 KABELD. 12-30	R911306336 7:20
DB-39161	 MUTTER-KOM-M 5,0-D10-H05,80 A2-B	R911210162 1:1
DB-46879	 SCHELLE-SCHL-S012*022-B12-ZN-SW7*S-3017	R911274471 1:2
DB-46866	 SCHELLE-SCHL-S023*035*B12-ZN-SW7*S-3017	R911274472 1:2
DB-38405	 SCHR-LIN-M 6,0X12,0-K-8.8-ISO7045-ZN-Z41	R911252551 1:1

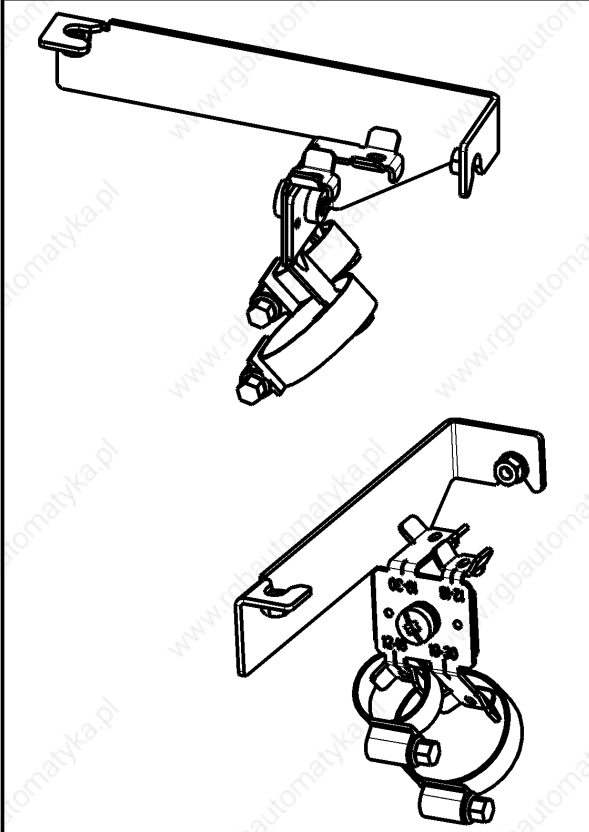

Datum	2004-03-02	Benennung	BEIPACKZETTEL HAS02.1-006-NNN-NN
Name	Hirt / Slevén	Material-Nr.	R911306726
Material-Nr.	R911306726	Zeich-Nr.	109-1253-4231-01
Datei	DB166624	Ers.durch	..
		AEM-Nr.	5-07273

Fig.14-34: Accompanying note

Accessories in the Drive System Rexroth IndraDrive

Made in Germany  
109-1253-4822-01



# HAS02.1-007-NNN-NN



R911306723

3	SCHR-LIN-M 6,0X12,0-K-8.8-ISO7045-ZN-Z41	R911252551
1	SCHIRMANBINDUNG	R911024565
1	SHELLE-SCHL-S032*050-B12-ZN-SW7*S-3017	R911296565
2	SHELLE-SCHL-S023*035*B12-ZN-SW7*S-3017	R911274472
1	HALTER SCHIRMANBINDUNG	R911024564
Stck	Benennung	MN

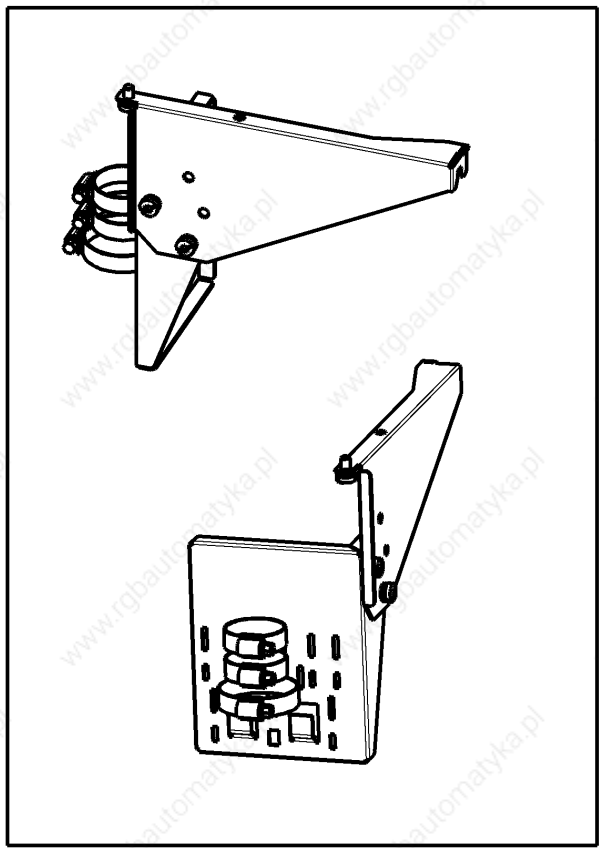





BEIPACKZETTEL HAS02.1-007-NNN-NN		
Stck	Benennung	MN
1	HALTER SCHIRMANBINDUNG	R911024564
DB166573		1:5
2	SHELLE-SCHL-S023*035*B12-ZN-SW7*S-3017	R911274472
DB_16668		1:2
1	SHELLE-SCHL-S032*050-B12-ZN-SW7*S-3017	R911296565
DB148043		7:20
1	SCHIRMANBINDUNG	R911024565
DB166572		1:4
3	SCHR-LIN-M 6,0X12,0-K-8.8-ISO7045-ZN-Z41	R911252551
DB_38705		1:1
Datum	2004-03-02	Benennung
Name	Hirt / Steven	BEIPACKZETTEL HAS02.1-007-NNN-NN
Material-Nr.	R911306727	Zeich-Nr. 109-1253-4232-01
Datei	DB166625	Ers.durch .. AEM-Nr. 5-07273

Fig. 14-35: Accompanying note

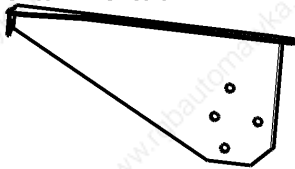
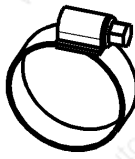

Accessories in the Drive System Rexroth IndraDrive

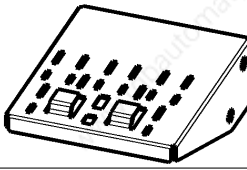
Made in Germany









## HAS02.1-008-NNN-NN



R911309579

Stck	Benennung	MN
4	SECHSKANTSCHRAUBE ISO4017-M6X12-8.8-A2C	R900014492
4	SCHR-LIN-M 6,0X12,0-K-8.8-ISO7045-ZN-Z41	R911252551
1	SCHIRMAUFLAGE HCS210	0025285
4	SHELLE-SCHL-S023*035*B12-ZN-SW7*S-3017	R911274472
4	SCHLEIBE 6,40X 12,00X 1,60 DIN 125	R911212427
2	HALTER SCHIRMAUFLAGE HCS210	0025286
4	FEDERRING B 6,0 DIN 127 ZN	R911213515
Stck	Benennung	MN

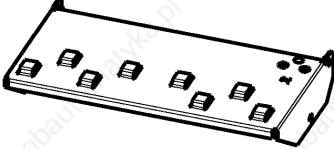
### BEIPACKZETTEL HAS02.1-008-NNN-NN

Stck	Benennung	MN
DB-55462	 FEDERRING B 6,0 DIN 127 ZN	R911213515 1:1
DB178733	 HALTER SCHIRMAUFLAGE HCS210	0025286 3:20
DB-42275	 SCHEIBE 6,40X 12,00X 1,60 DIN 125	R911212427 1:1
DB-46688	 SCHELLE-SCHL-S023*035*B12-ZN-SW7*S-3017	R911274472 1:2
DB178731	 SCHIRMAUFLAGE HCS210	0025285 3:20
DB-38405	 SCHR-LIN-M 6,0X12,0-K-8.8-ISO7045-ZN-Z41	R911252551 1:1
DB178750	 SECHSKANTSCHRAUBE ISO4017-M6X12-8.8-A2C	R900014492 1:1

Datum	2004-11-08	Benennung	BEIPACKZETTEL HAS02.1-008-NNN-NN
Name	Sieven	Zeich-Nr.	109-1253-4233-00
Material-Nr.		Ers.durch	..
Datei	DB178779	AEM-Nr.	..

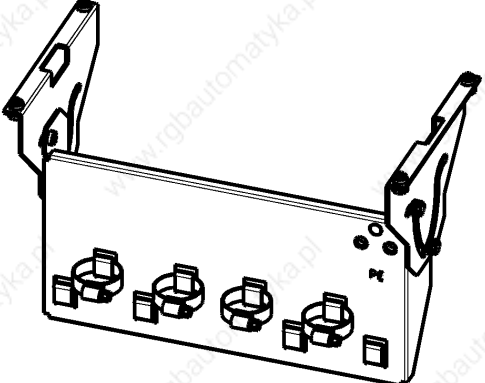



Fig.14-36: Accompanying note

Accessories in the Drive System Rexroth IndraDrive

Made in Germany  
109-1253-4824-00







## HAS02.1-009-NNN-NN

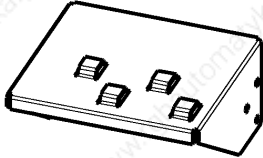
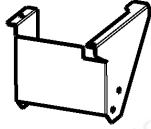

R911308225

6	SCHR-LIN-M 6,0X12,0-K-8.8-ISO7045-ZN-Z41	R911252551
1	SCHELLE-SCHL-S032*050-B12-ZN-SW7*S-3017	R911296565
2	SCHELLE-SCHL-S023*035*B12-ZN-SW7*S-3017	R911274472
1	HALTER SCHIRMBLECH	R911025035
1	BLECH-SCHIRMAUFLAGE	R911025036
Stck	Benennung	MN

**BEIPACKZETTEL HAS02.1-009-NNN-NN**

Stck	Benennung	MN
DB171916	1 BLECH-SCHIRMAUFLAGE 	R911025036 1:5
DB171914	1 HALTER SCHIRMBLECH 	R911025035 1:10
DB-46868	2 SCHELLE-SCHL-S023*035*B12-ZN-SW7*S-3017 	R911274472 1:4
DB1748043	1 SCHELLE-SCHL-S032*050-B12-ZN-SW7*S-3017 	R911296565 1:4
DB-38705	6 SCHR-LIN-M 6,0X12,0-K-8.8-ISO7045-ZN-Z41 	R911252551 1:1

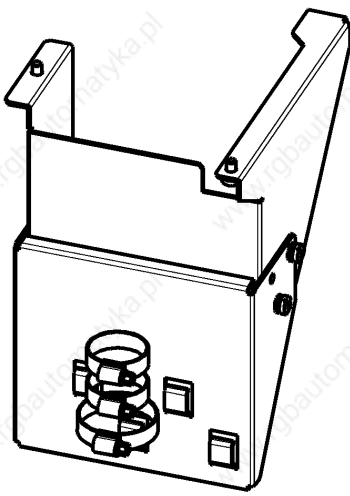

Datum	2004-07-06	Benennung
Name	Hirt	BEIPACKZETTEL HAS02.1-009-NNN-NN
Material-Nr.	R911308255	Zeich-Nr. 109-1253-4234-00
Datei	DB171948	Ers.durch ... AEM-Nr. ...

Fig.14-37: Accompanying note

Accessories in the Drive System Rexroth IndraDrive







<p>Made in Germany 109-1253-4841-00</p> <p style="text-align: right;"><b>Rexroth Bosch Group</b></p> <h2 style="text-align: center;">HAS02.1-010-NNN-NN</h2> <div style="text-align: center;">               R911306209         </div> <table border="1" style="width: 100%; border-collapse: collapse; margin-top: 20px;"> <tr> <td style="width: 5%;">1</td> <td style="width: 75%;">KLEMME SK 20</td> <td style="width: 20%;">R911313176</td> </tr> <tr> <td>1</td> <td>BLECH HMS02.1-W0054 ABSCHIRMANSCHLUSS</td> <td>R911311526</td> </tr> <tr> <td><b>Stck</b></td> <td><b>Benennung</b></td> <td><b>MN</b></td> </tr> </table>	1	KLEMME SK 20	R911313176	1	BLECH HMS02.1-W0054 ABSCHIRMANSCHLUSS	R911311526	<b>Stck</b>	<b>Benennung</b>	<b>MN</b>	<table border="1" style="width: 100%; border-collapse: collapse;"> <tr> <th colspan="3" style="text-align: center;">BEIPACKZETTEL HAS021-010-NNN-NN</th> </tr> <tr> <th style="width: 10%;">Stck</th> <th style="width: 70%;">Benennung</th> <th style="width: 20%;">MN</th> </tr> <tr> <td style="text-align: center;">1</td> <td>BLECH HMS02.1-W0054 ABSCHIRMANSCHLUSS</td> <td style="text-align: center;">R911311526</td> </tr> <tr> <td style="text-align: center;">1</td> <td>KLEMME SK 20</td> <td style="text-align: center;">R911313176</td> </tr> <tr> <td colspan="3" style="text-align: center;">  </td> </tr> <tr> <td colspan="3" style="text-align: center;">  </td> </tr> <tr> <td colspan="3" style="text-align: center;"> <table border="1" style="width: 100%; border-collapse: collapse; margin-top: 20px;"> <tr> <td style="width: 25%;">Datum</td> <td style="width: 25%;">2005-08-19</td> <td style="width: 50%;">Benennung</td> </tr> <tr> <td>Name</td> <td>rainhirt</td> <td>BEIPACKZETTEL HAS02.1-010-NNN-NN</td> </tr> <tr> <td>Material-Nr.</td> <td>R911313050</td> <td>Zeich-Nr. 109-1253-4277-00</td> </tr> <tr> <td>Datei</td> <td>DB190746</td> <td>Ers.durch .. AEM-Nr. ..</td> </tr> </table> </td> </tr> </table>	BEIPACKZETTEL HAS021-010-NNN-NN			Stck	Benennung	MN	1	BLECH HMS02.1-W0054 ABSCHIRMANSCHLUSS	R911311526	1	KLEMME SK 20	R911313176							<table border="1" style="width: 100%; border-collapse: collapse; margin-top: 20px;"> <tr> <td style="width: 25%;">Datum</td> <td style="width: 25%;">2005-08-19</td> <td style="width: 50%;">Benennung</td> </tr> <tr> <td>Name</td> <td>rainhirt</td> <td>BEIPACKZETTEL HAS02.1-010-NNN-NN</td> </tr> <tr> <td>Material-Nr.</td> <td>R911313050</td> <td>Zeich-Nr. 109-1253-4277-00</td> </tr> <tr> <td>Datei</td> <td>DB190746</td> <td>Ers.durch .. AEM-Nr. ..</td> </tr> </table>			Datum	2005-08-19	Benennung	Name	rainhirt	BEIPACKZETTEL HAS02.1-010-NNN-NN	Material-Nr.	R911313050	Zeich-Nr. 109-1253-4277-00	Datei	DB190746	Ers.durch .. AEM-Nr. ..
1	KLEMME SK 20	R911313176																																									
1	BLECH HMS02.1-W0054 ABSCHIRMANSCHLUSS	R911311526																																									
<b>Stck</b>	<b>Benennung</b>	<b>MN</b>																																									
BEIPACKZETTEL HAS021-010-NNN-NN																																											
Stck	Benennung	MN																																									
1	BLECH HMS02.1-W0054 ABSCHIRMANSCHLUSS	R911311526																																									
1	KLEMME SK 20	R911313176																																									
																																											
																																											
<table border="1" style="width: 100%; border-collapse: collapse; margin-top: 20px;"> <tr> <td style="width: 25%;">Datum</td> <td style="width: 25%;">2005-08-19</td> <td style="width: 50%;">Benennung</td> </tr> <tr> <td>Name</td> <td>rainhirt</td> <td>BEIPACKZETTEL HAS02.1-010-NNN-NN</td> </tr> <tr> <td>Material-Nr.</td> <td>R911313050</td> <td>Zeich-Nr. 109-1253-4277-00</td> </tr> <tr> <td>Datei</td> <td>DB190746</td> <td>Ers.durch .. AEM-Nr. ..</td> </tr> </table>			Datum	2005-08-19	Benennung	Name	rainhirt	BEIPACKZETTEL HAS02.1-010-NNN-NN	Material-Nr.	R911313050	Zeich-Nr. 109-1253-4277-00	Datei	DB190746	Ers.durch .. AEM-Nr. ..																													
Datum	2005-08-19	Benennung																																									
Name	rainhirt	BEIPACKZETTEL HAS02.1-010-NNN-NN																																									
Material-Nr.	R911313050	Zeich-Nr. 109-1253-4277-00																																									
Datei	DB190746	Ers.durch .. AEM-Nr. ..																																									

Fig.14-38: Accompanying note

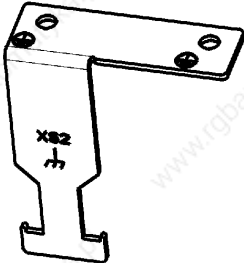
Accessories in the Drive System Rexroth IndraDrive

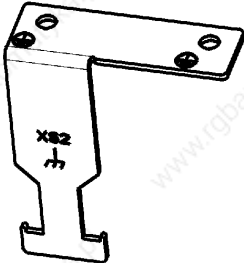

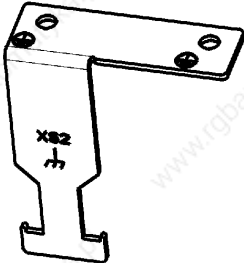
<p>Made in Germany 109-1253-4842-00</p> <p style="text-align: right;"><b>Rexroth Bosch Group</b></p> <p style="text-align: center; font-size: 24px; font-weight: bold;">HAS02.1-011-NNN-NN</p> <div style="text-align: center;">  <p>R911306471</p> </div> <table border="1" style="width: 100%; border-collapse: collapse; margin-top: 10px;"> <tr> <td style="width: 10%; text-align: center;">1</td> <td style="width: 70%;">KLEMME SK 20</td> <td style="width: 20%; text-align: center;">R911313176</td> </tr> <tr> <td style="text-align: center;">1</td> <td>BLECH HMS02.1 W0028 ABSCHIRMANSCHLUSS</td> <td style="text-align: center;">R911311525</td> </tr> <tr> <td style="text-align: center;"><b>Stck</b></td> <td style="text-align: center;"><b>Benennung</b></td> <td style="text-align: center;"><b>MN</b></td> </tr> </table>	1	KLEMME SK 20	R911313176	1	BLECH HMS02.1 W0028 ABSCHIRMANSCHLUSS	R911311525	<b>Stck</b>	<b>Benennung</b>	<b>MN</b>	<p style="text-align: center; font-weight: bold;">BEIPACKZETTEL HAS02.1-011-NNN-NN</p> <table border="1" style="width: 100%; border-collapse: collapse;"> <thead> <tr> <th style="width: 10%;">Stck</th> <th style="width: 70%;">Benennung</th> <th style="width: 20%;">MN</th> </tr> </thead> <tbody> <tr> <td style="text-align: center;">1</td> <td>BLECH HMS02.1 W0028 ABSCHIRMANSCHLUSS</td> <td style="text-align: center;">R911311525</td> </tr> <tr> <td style="text-align: center;">1</td> <td>KLEMME SK 20</td> <td style="text-align: center;">R911313176</td> </tr> </tbody> </table> <div style="margin-top: 10px;">   </div> <table border="1" style="width: 100%; border-collapse: collapse; margin-top: 10px;"> <tr> <td style="width: 15%;">Datum</td> <td style="width: 35%;">2005-08-19</td> <td style="width: 15%;">Benennung</td> <td style="width: 35%;">BEIPACKZETTEL HAS02.1-011-NNN-NN</td> </tr> <tr> <td>Name</td> <td>rainhirt</td> <td>Material-Nr.</td> <td>R911306628</td> </tr> <tr> <td>Material-Nr.</td> <td>R911306628</td> <td>Zeich-Nr.</td> <td>109-1253-4278-00</td> </tr> <tr> <td>Datei</td> <td>DB190747</td> <td>Ers.durch</td> <td>...</td> </tr> <tr> <td></td> <td></td> <td>AEM-Nr.</td> <td>...</td> </tr> </table>	Stck	Benennung	MN	1	BLECH HMS02.1 W0028 ABSCHIRMANSCHLUSS	R911311525	1	KLEMME SK 20	R911313176	Datum	2005-08-19	Benennung	BEIPACKZETTEL HAS02.1-011-NNN-NN	Name	rainhirt	Material-Nr.	R911306628	Material-Nr.	R911306628	Zeich-Nr.	109-1253-4278-00	Datei	DB190747	Ers.durch	...			AEM-Nr.	...
1	KLEMME SK 20	R911313176																																					
1	BLECH HMS02.1 W0028 ABSCHIRMANSCHLUSS	R911311525																																					
<b>Stck</b>	<b>Benennung</b>	<b>MN</b>																																					
Stck	Benennung	MN																																					
1	BLECH HMS02.1 W0028 ABSCHIRMANSCHLUSS	R911311525																																					
1	KLEMME SK 20	R911313176																																					
Datum	2005-08-19	Benennung	BEIPACKZETTEL HAS02.1-011-NNN-NN																																				
Name	rainhirt	Material-Nr.	R911306628																																				
Material-Nr.	R911306628	Zeich-Nr.	109-1253-4278-00																																				
Datei	DB190747	Ers.durch	...																																				
		AEM-Nr.	...																																				

Fig. 14-39: Accompanying note

Accessories in the Drive System Rexroth IndraDrive

Made in Germany  
109-1253-4850-00

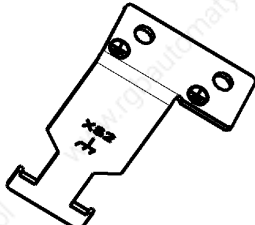
**Rexroth**  
**Bosch Group**







## HAS02.1-012-NNN-NN



R911315682

1	WINKEL HCS03.1E-W0210 ABSCHIRMANSCHLUSS	R911025285
4	SECHSKANTSCHRAUBE ISO4017-M6X12-8.8-A2C	R900014492
4	SCHR-LIN-M 6,0X12,0-K-8.8-ISO7045-ZN-Z41	R911252551
4	SHELLE-SCHL-S032*050-B12-ZN-SW7*S-3017	R911296565
4	SCHEIBE 6,40X 12,00X 1,60 DIN 125	R911212427
4	FEDERRING DIN127-B6-FST &	R911213515
2	BLECH HCS04.1E-W0500 ABSCHIRMANSCHLUSS	R911027316
<b>Stck</b>	<b>Benennung</b>	<b>MN</b>

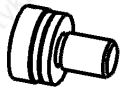
**BEIPACKZETTEL HAS02.1-012-NNN-NN**

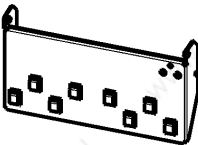
Stck	Benennung	MN
DB195166	2 BLECH HCS04.1E-W0500 ABSCHIRMANSCHLUSS	R911027316
		1:10
DB-53462	4 FEDERRING DIN127-B6-FST &	R911213515
		1:1
DB-42275	4 SCHEIBE 6,40X 12,00X 1,60 DIN 125	R911212427
		1:1
DB148043	4 SHELLE-SCHL-S032*050-B12-ZN-SW7*S-3017	R911296565
		2:5
DB-38405	4 SCHR-LIN-M 6,0X12,0-K-8.8-ISO7045-ZN-Z41	R911252551
		1:1
DB187150	4 SECHSKANTSCHRAUBE ISO4017-M6X12-8.8-A2C	R900014492
		1:1
DB186125	1 WINKEL HCS03.1E-W0210 ABSCHIRMANSCHLUSS	R911025285
		1:10

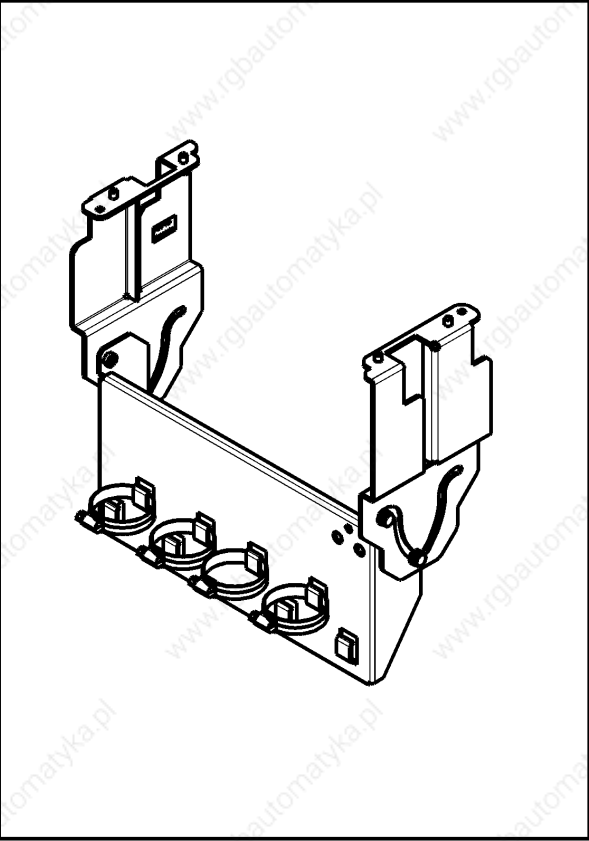

Datum	2006-01-19	Benennung
Name	Sonjrazz	BEIPACKZETTEL HAS02.1-012-NNN-NN
Material-Nr.	R911315849	Zeich-Nr. 109-1253-4284-00
Datei	DB195390	Ers.durch .. AEM-Nr. ..

Fig.14-40: Accompanying note

Accessories in the Drive System Rexroth IndraDrive

Made in Germany  
109-1287-4820-00

**Rexroth  
Bosch Group**

## HAS02.1-013-NNN-NN

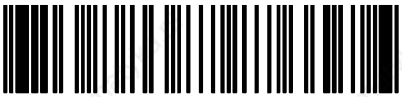

R911318183

4	SCHELLE-SCHL-S032*050-B12-ZN-SW7*S-3017	R911296565
8	KOMBI-SCHRAUBE ZISO10644-M6X16-8.8 &	R911294530
1	0027843 SCHIRMAUFLAGE HCS0500	R911203470
1	0027842 HALTER SCHIRMAUFLAGE HCS0500	R911203471
<b>Stck</b>	<b>Benennung</b>	<b>MN</b>

**BEIPACKZETTEL HAS02.1-013-NNN-NN**

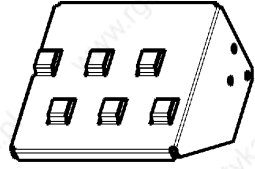
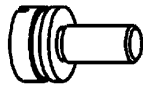
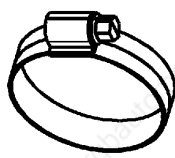
Stck	Benennung	MN
08204197	1 0027842 HALTER SCHIRMAUFLAGE HCS0500 	R911203471  1:5
08199332	1 0027843 SCHIRMAUFLAGE HCS0500 	R911203470  1:5
08149085	8 KOMBI-SCHRAUBE ZISO10644-M6X16-8.8 & 	R911294530  1:1
08148043	4 SCHELLE-SCHL-S032*050-B12-ZN-SW7*S-3017 	R911296565  1:2

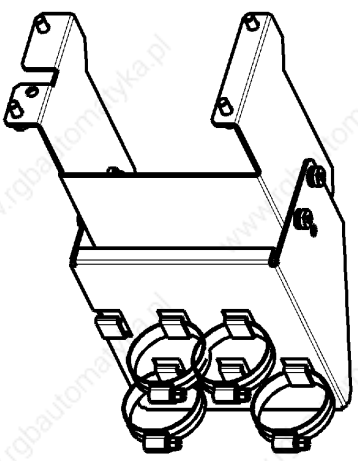

<b>Datum</b>	2006-08-21	<b>Benennung</b>
<b>Name</b>	mottamel	BEIPACKZETTEL HAS02.1-013-NNN-NN
<b>Material-Nr.</b>	R911318184	<b>Zeich-Nr.</b> 109-1287-4203-00
<b>Datei</b>	08204202	<b>Ers.durch</b> ... <b>AEM-Nr.</b> ...

Fig.14-41: Accompanying note

Accessories in the Drive System Rexroth IndraDrive

Made in Germany  
109-1253-4857-00

**Rexroth  
Bosch Group**

## HAS02.1-014-NNN-NN



R911319050

Stck	Benennung	MN
1	WINKEL HCS03.1E-W0210 ABSCHIRMANSCHLUSS	R911025285
4	SECHSKANTSCHRAUBE ISO4017-M6X12-8.8-A2C	R900014492
1	SHELLE-SCHL-S032*050-B12-ZN-SW7*S-3017	R911296565
2	SHELLE-SCHL-S023*035*B12-ZN-SW7*S-3017	R911274472
4	SCHEIBE 6,40X 12,00X 1,60 DIN 125	R911212427
4	KOMBI-SCHRAUBE ZISO10644-M6X12-8.8 &	R911252551
4	FEDERRING DIN127-B6-FST &	R911213515
2	BLECH HMS01.1-W0350 ABSCHIRMANSCHLUSS	R911318661
Stck	Benennung	MN

**BEIPACKZETTEL HAS02.1-014-NNN-NN**

Stck	Benennung	MN
2	BLECH HMS01.1-W0350 ABSCHIRMANSCHLUSS	R911318661
4	FEDERRING DIN127-B6-FST &	R911213515
4	KOMBI-SCHRAUBE ZISO10644-M6X12-8.8 &	R911252551
4	SCHEIBE 6,40X 12,00X 1,60 DIN 125	R911212427
2	SHELLE-SCHL-S023*035*B12-ZN-SW7*S-3017	R911274472
1	SHELLE-SCHL-S032*050-B12-ZN-SW7*S-3017	R911296565
4	SECHSKANTSCHRAUBE ISO4017-M6X12-8.8-A2C	R900014492
1	WINKEL HCS03.1E-W0210 ABSCHIRMANSCHLUSS	R911025285

<b>Datum</b>	2006-10-11	<b>Benennung</b>	BEIPACKZETTEL HAS02.1-014-NNN-NN
<b>Name</b>	siegfisd	<b>Material-Nr.</b>	R911319013
<b>Material-Nr.</b>	R911319013	<b>Zeich-Nr.</b>	109-1253-4298-00
<b>Datei</b>	DB205990	<b>Ers.durch</b>	..
		<b>AEM-Nr.</b>	..

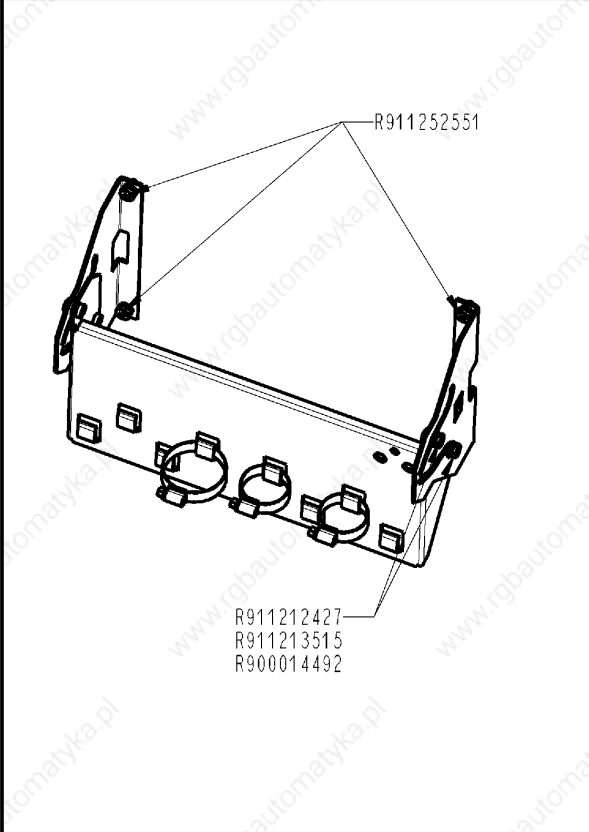
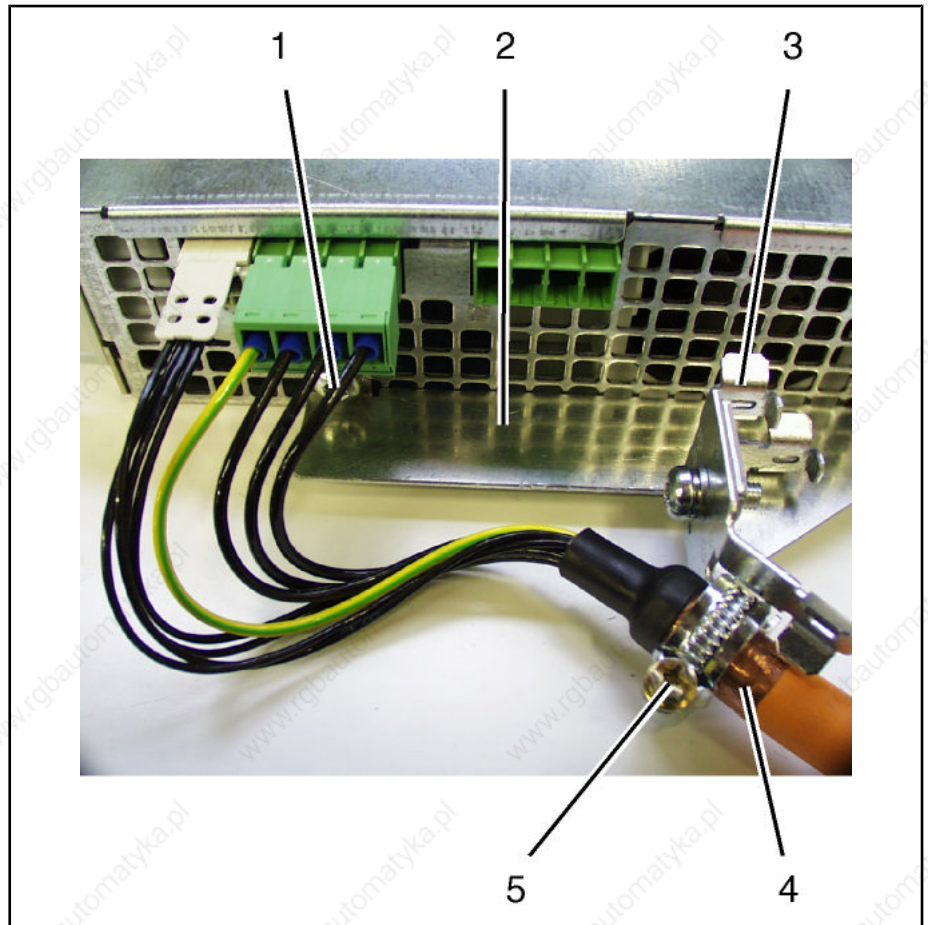

Fig.14-42: Accompanying note



## 14.2.6 Mounting the Accessory HAS02

### General Information



- |   |                                  |
|---|----------------------------------|
| 1 | screw in thread XS2              |
| 2 | fixing device of shielding plate |
| 3 | shielding plate                  |
| 4 | shield of motor cable            |
| 5 | clip                             |

Fig. 14-43: Shield connection of motor cable

- Unscrew bottom or bottom left fixing screw of drive controller.
- Put fixing device of accessories to bottom of drive controller and screw down fixing screw of drive controller again.



**CAUTION**

#### Risk of damage to the drive controller caused by too long screws!

Exclusively use the supplied screws of a length of **12 mm** for the thread of the shield connection XS2.

- Screw second screw (M6 x 12) in thread XS2 at bottom of drive controller.
- Screw shielding plate to sheet metal of accessories according to desired cable routing of motor cable (45° or horizontal). (The figure below illustrates cable routing with 45°.)
- According to diameter of motor cable, fix motor cable at corresponding point of shielding plate (12–18 mm or 19–30 mm) with a clip. Make sure that shield of motor cable has good contact with shielding plate (see figure below).

Accessories in the Drive System Rexroth IndraDrive

HAS02.1-001 at HMS01.1N-W0054

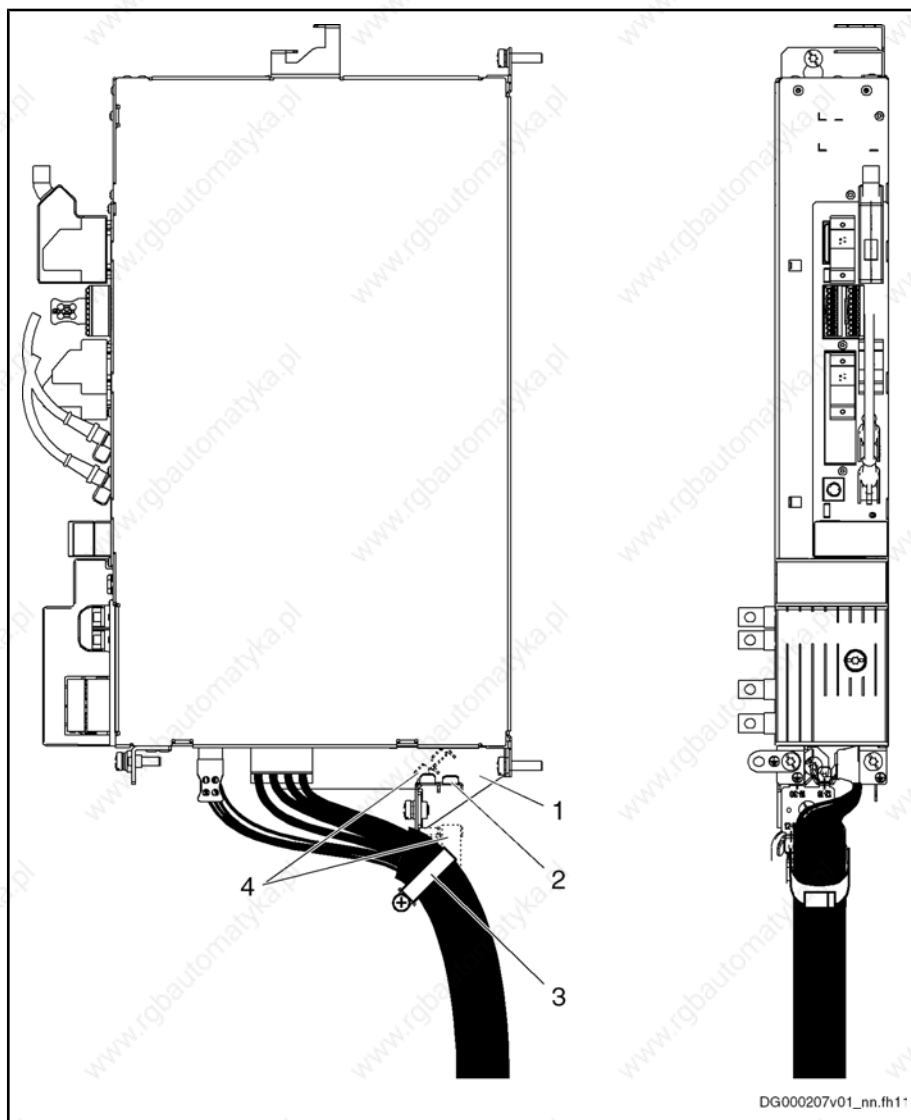

- 1 fixing device
- 2 shielding plate
- 3 clip
- 4 different possibilities of mounting the shielding plate, according to motor cable routing

Fig. 14-44: HAS02.1-001 at bottom of drive controller HMS01.1N-W0054

**Mounting**

1. By means of supplied screws, fasten fixing device to bottom of drive controller.
2. Fix shielding plate to fixing device according to desired motor cable routing.
3. Fix shield of cable to shielding plate with appropriate clip.

## HAS02.1-002 at HCS02.1E-W0054

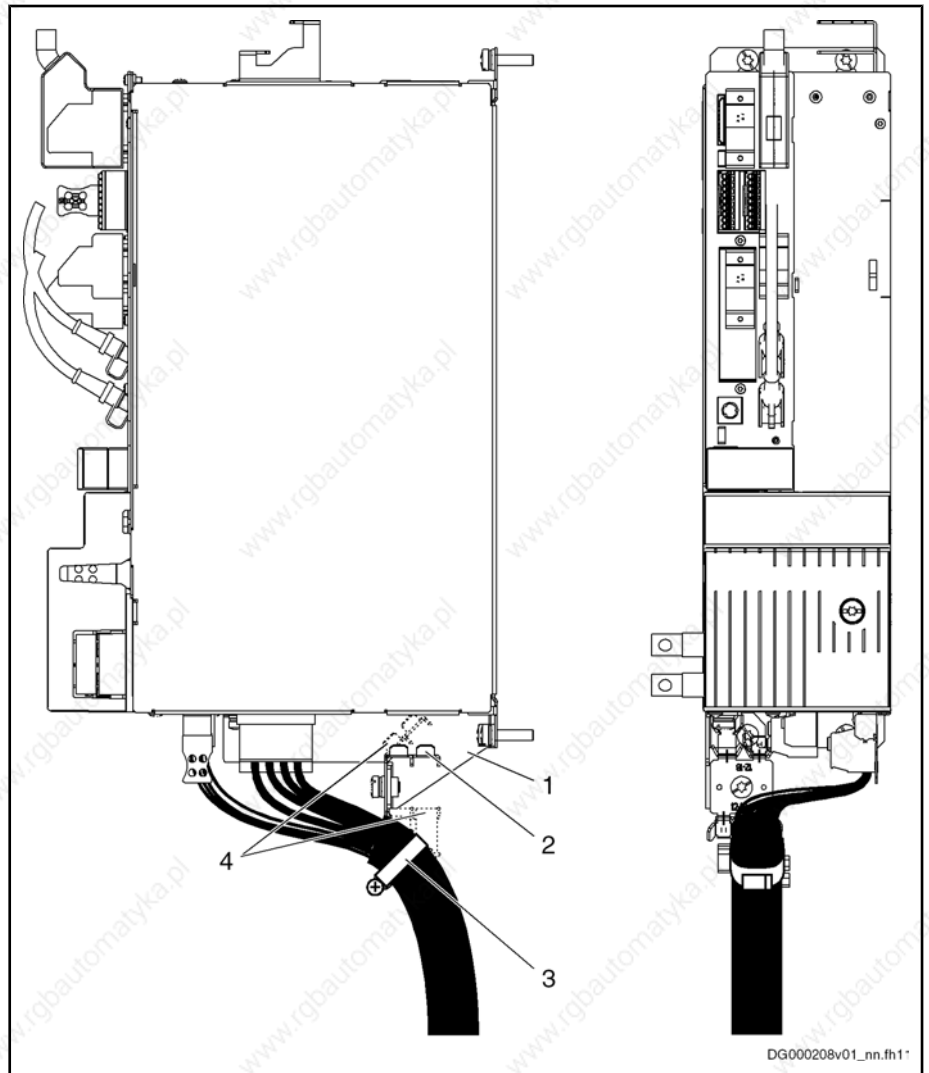

DG000208v01\_nn.fh11

- |   |   |
|---|---|
| 1 | fixing device   |
| 2 | shielding plate   |
| 3 | clip  |
| 4 | different possibilities of mounting the shielding plate, according to motor cable routing |

Fig. 14-45: HAS02.1-002 at bottom of drive controller HCS02.1E-W0054

**Mounting**

1. By means of supplied screws, fasten fixing device to bottom of drive controller.
2. Fix shielding plate to fixing device according to desired motor cable routing.
3. Fix shield of cable to shielding plate with appropriate clip.

Accessories in the Drive System Rexroth IndraDrive

HAS02.1-003 at HMS01.1N-W0210

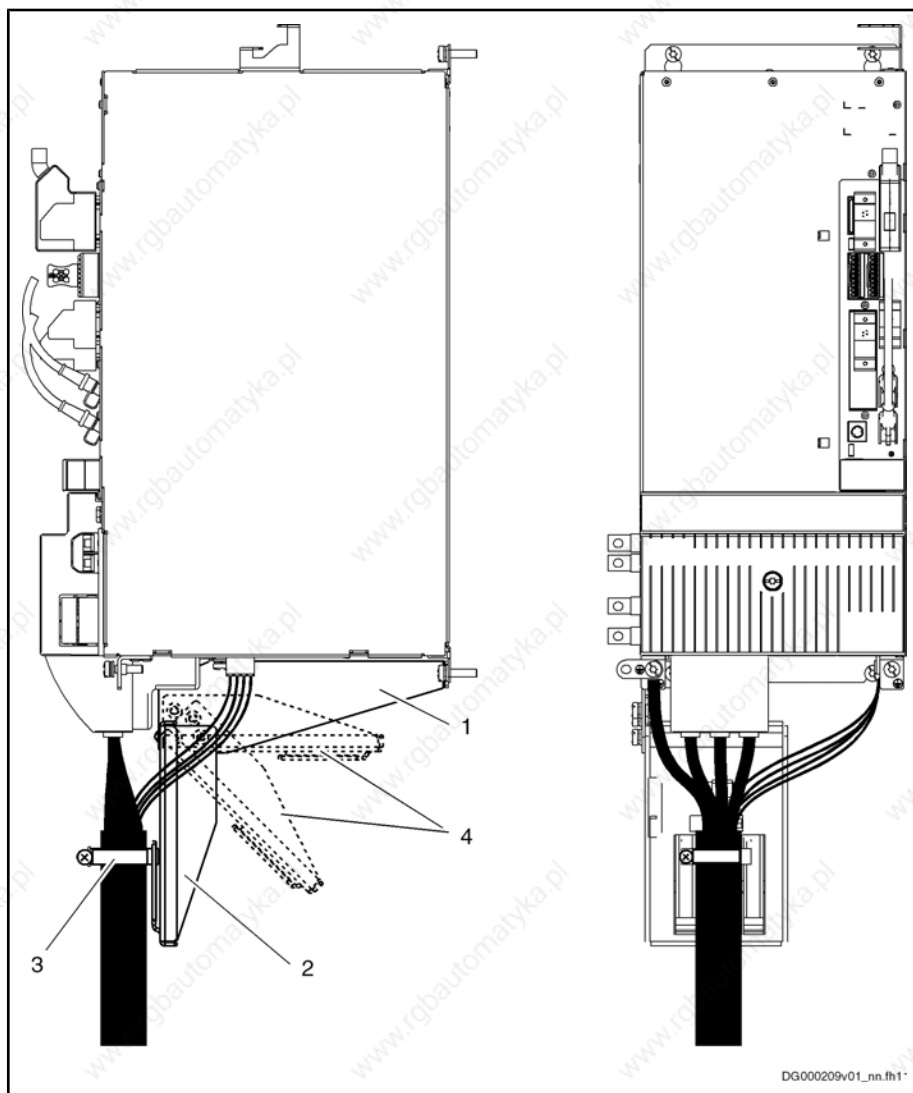

- 1 fixing device
- 2 shielding plate
- 3 clip
- 4 different possibilities of mounting the shielding plate, according to motor cable routing

Fig.14-46: HAS02.1-003 at bottom of drive controller HMS01.1N-W0210

**Mounting**

1. By means of supplied screws, fasten fixing device to bottom of drive controller.
2. Fix shielding plate to fixing device according to desired motor cable routing.
3. Fix shield of cable to shielding plate with appropriate clip.

## Accessories in the Drive System Rexroth IndraDrive

## HAS02.1-004 at HCS03.1E-W0070

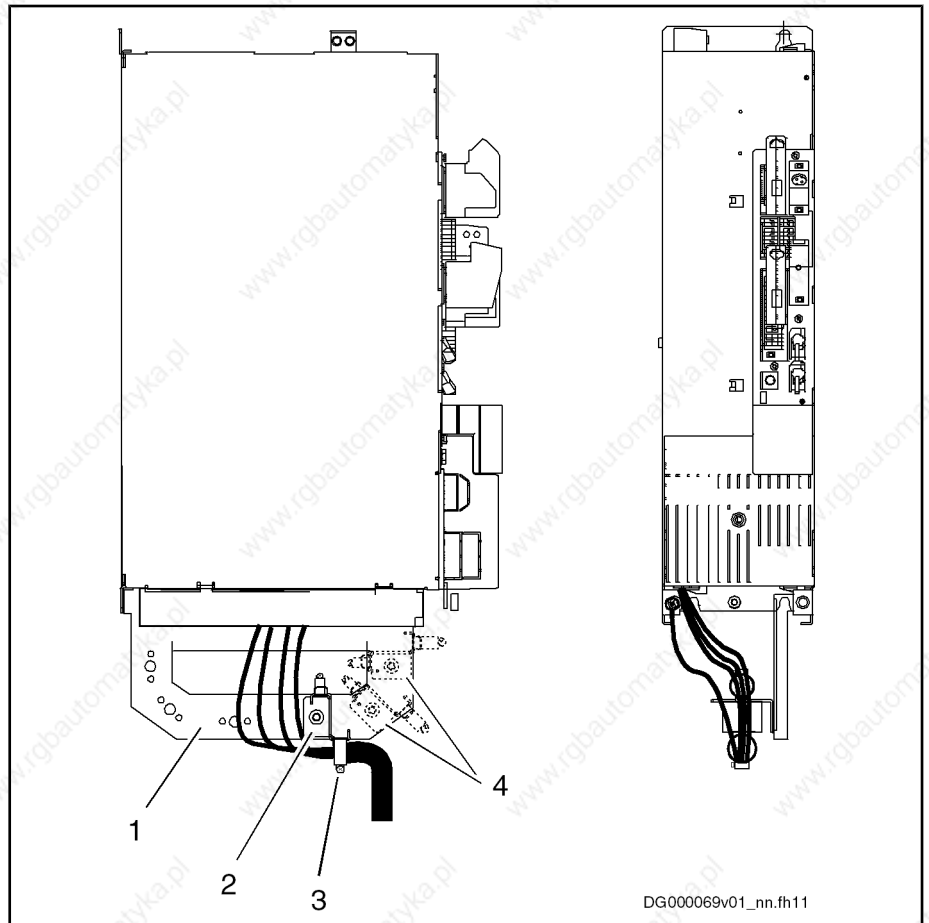

- |   |   |
|---|---|
| 1 | fixing device   |
| 2 | shielding plate   |
| 3 | clip  |
| 4 | different possibilities of mounting the shielding plate, according to motor cable routing |

Fig. 14-47: HAS02.1-004 at bottom of drive controller HCS03.1E-W0070

**Mounting**

1. By means of supplied screws, fasten fixing device to bottom of drive controller.
2. Fix shielding plate to fixing device according to desired motor cable routing.
3. Fix shield of cable to shielding plate with appropriate clip.

Accessories in the Drive System Rexroth IndraDrive

HAS02.1-005 at HCS03.1E-W0100 / 150

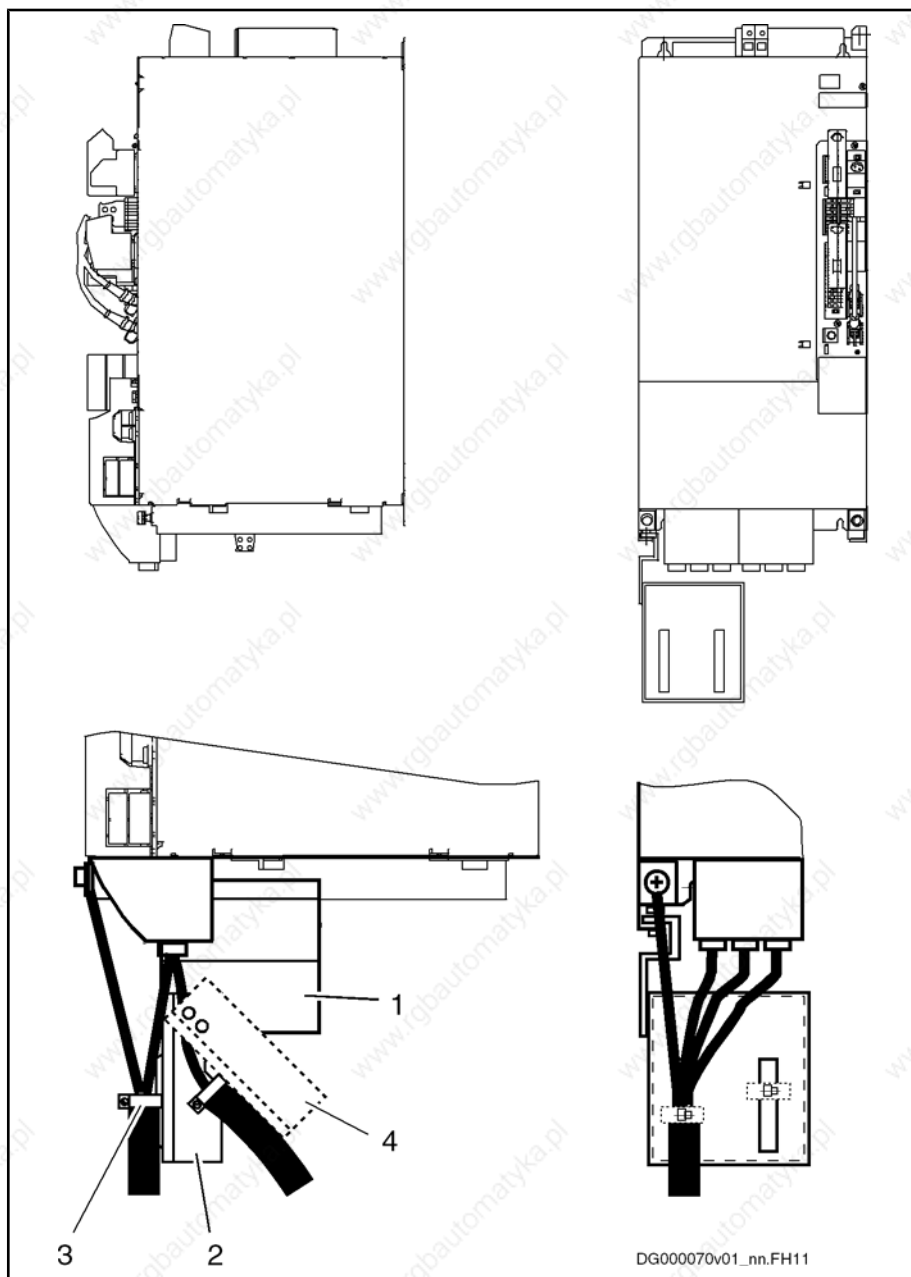

- 1 fixing device
- 2 shielding plate
- 3 clip
- 4 different possibilities of mounting the shielding plate, according to motor cable routing

Fig. 14-48: HAS02.1-005 at bottom of drive controller HCS03.1E-W0100 / 0150

**Mounting**

1. By means of supplied screws, fasten fixing device to bottom of drive controller.
2. Fix shielding plate to fixing device according to desired motor cable routing.
3. Fix shield of cable to shielding plate with appropriate clip.

Accessories in the Drive System Rexroth IndraDrive

HAS02.1-008 at HCS03.1E-W0210

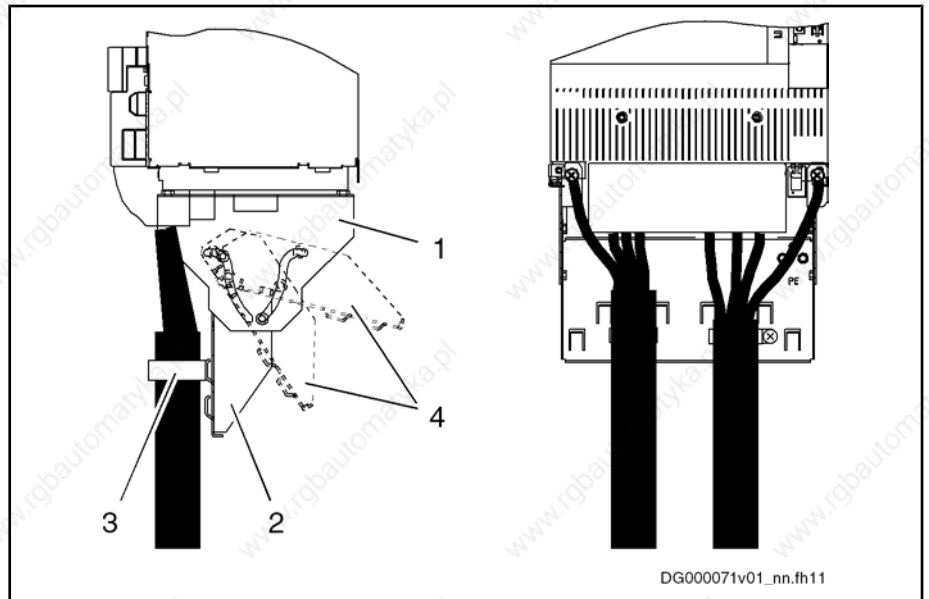

- 1 fixing device
- 2 shielding plate
- 3 clip
- 4 different possibilities of mounting the shielding plate, according to motor cable routing

Fig. 14-49: HAS02.1-008 at bottom of drive controller HCS03.1E-W0210

**Mounting**

1. By means of supplied screws, fasten fixing device to bottom of drive controller.
2. Fix shielding plate to fixing device according to desired motor cable routing.
3. Fix shield of cable to shielding plate with appropriate clip.

HAS02.1-010 at HMS02.1N-W0028 / 54

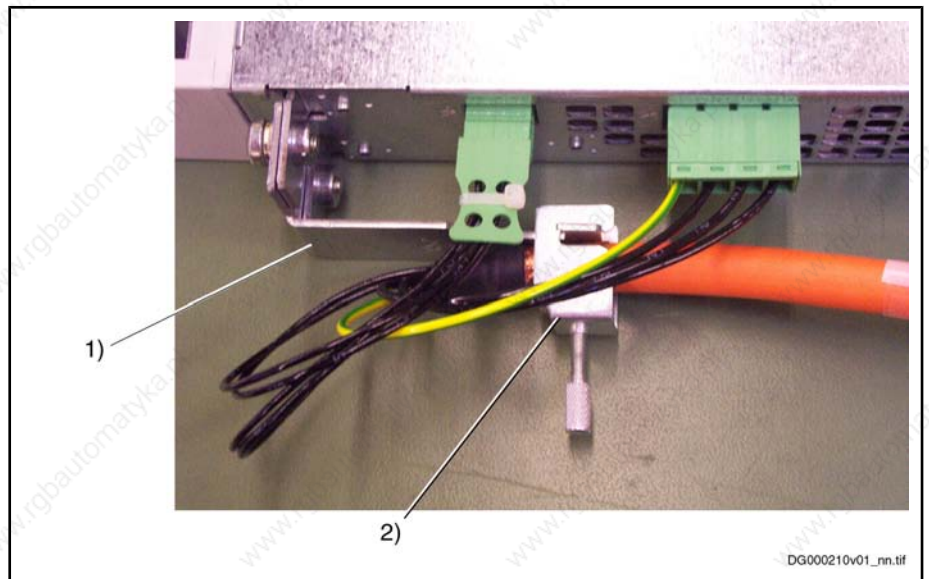

- 1 fixing device
- 2 shielding plate

Fig. 14-50: HAS02.1-010-NNN-NN at bottom of drive controller HMS02.1N-W0028 / 54



## Accessories in the Drive System Rexroth IndraDrive

1. Screw fixing device to equipment grounding conductor connection of drive controller.
2. Fix shield of cable with shielding plate to fixing device.

### HAS02.1-014 at HMS01.1N-W0350

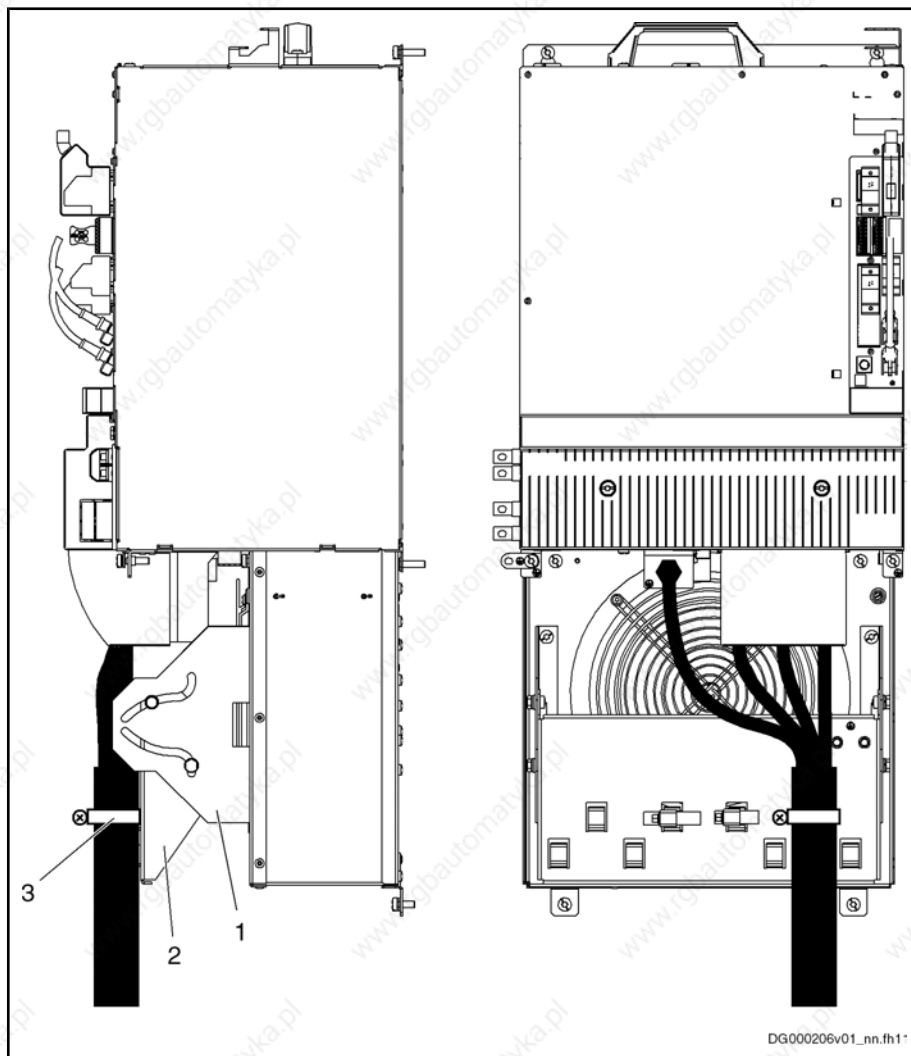

- 1 fixing device
- 2 shielding plate
- 3 clip

Fig. 14-51: HAS02.1-014 at bottom of drive controller HMS01.1N-W0350

1. By means of supplied screws, fasten fixing device to front of blower unit.
2. Fix shielding plate to fixing device.
3. Fix shield of cable to shielding plate with appropriate clip.

## 14.2.7 Shield Connection of the Motor Cable via Mains Filter

### General Information

There is a special shielding plate for shield connection of the motor cable via the mains filter at the drive controller:

## Accessories in the Drive System Rexroth IndraDrive



Using the shielding plate guarantees optimum shield contact of the motor cable. You should therefore, **where possible, always** use the shielding plate.

The shielding plate is only available as an option.

## HAS02.1-006 With Motor Cable and Mains Filter

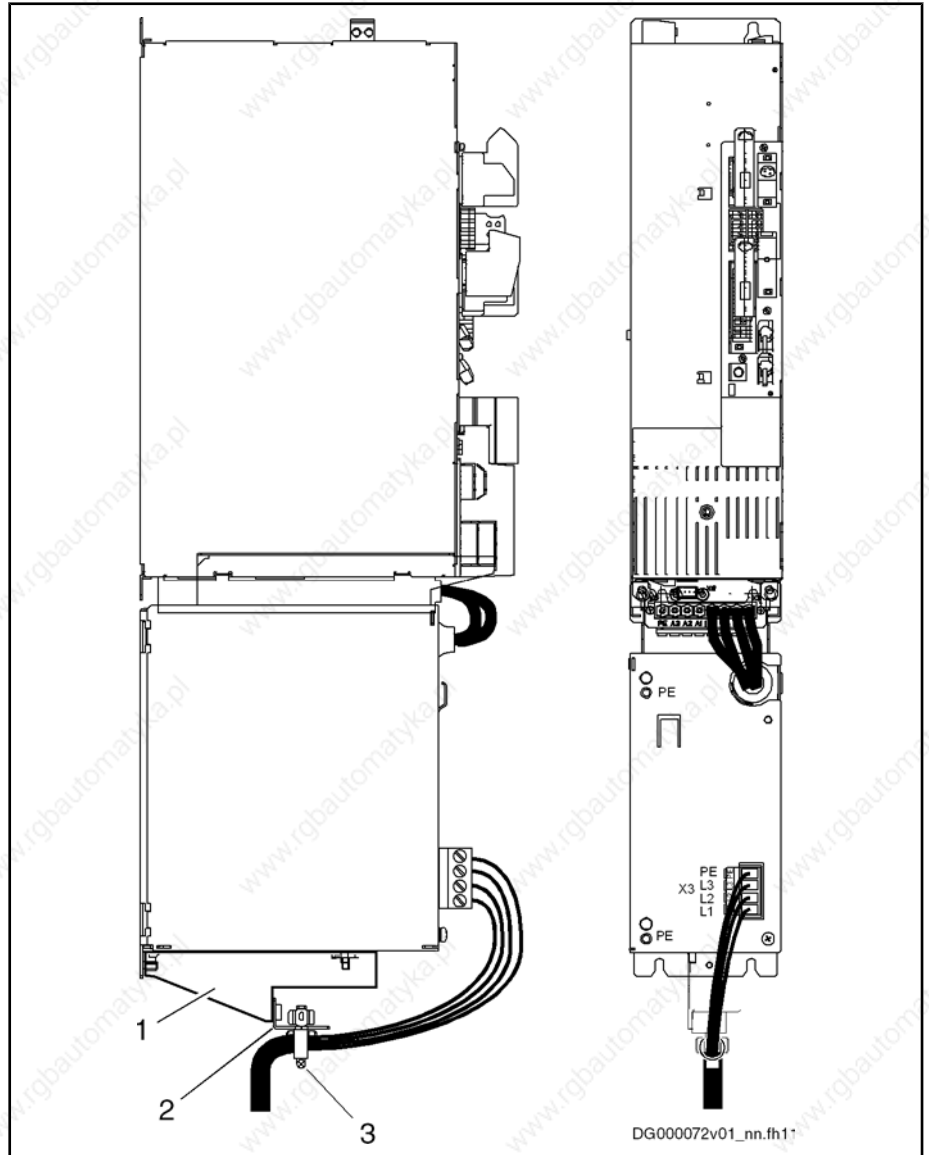

- 1 fixing device
- 2 shielding plate
- 3 clip

Fig. 14-52: HAS02.1-006 at bottom of mains filter (rated current 50 A)

1. Hang up fixing device at bottom of mains filter at threaded bolts and fasten with supplied nuts.

2. Screw shielding plate to fixing device.

3. Fix shield of cable to shielding plate with appropriate clip.



The shield terminals must not be used to provide strain relief.

Accessories in the Drive System Rexroth IndraDrive

HAS02.1-007 With Power Supply Cable and Mains Filter

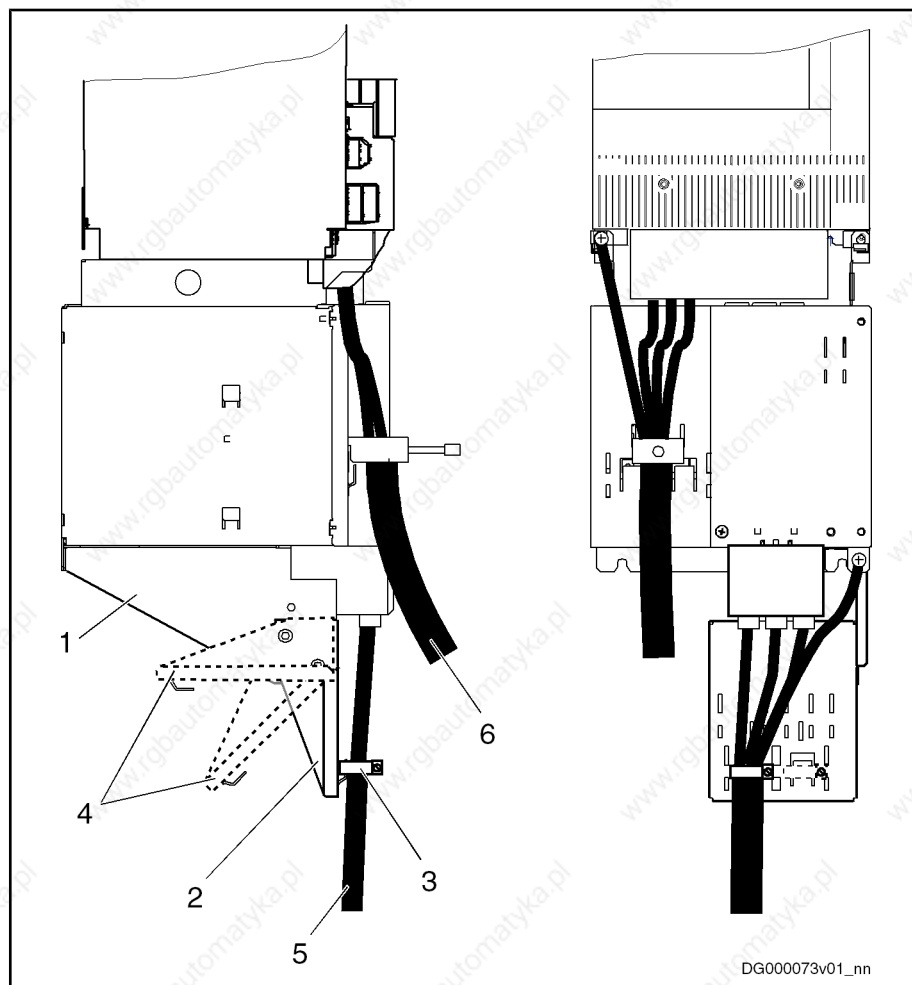

DG000073v01\_nn

- 1 fixing device
- 2 shielding plate
- 3 clip
- 4 different possibilities of mounting the shielding plate, according to cable routing
- 5 power supply cable
- 6 motor cable

Fig.14-53: HAS02.1-007 at bottom of mains filter (rated current 80 A / 106 A)

**1.** Hang up fixing device at bottom of mains filter and fasten with supplied screws.

**2.** Screw shielding plate to fixing device.

According to desired cable routing, the shielding plate can be mounted in different positions

**3.** Fix shield of cable to shielding plate with clip.



The shield terminals must not be used to provide strain relief.

## HAS02.1-009 With Power Supply Cable and Mains Filter

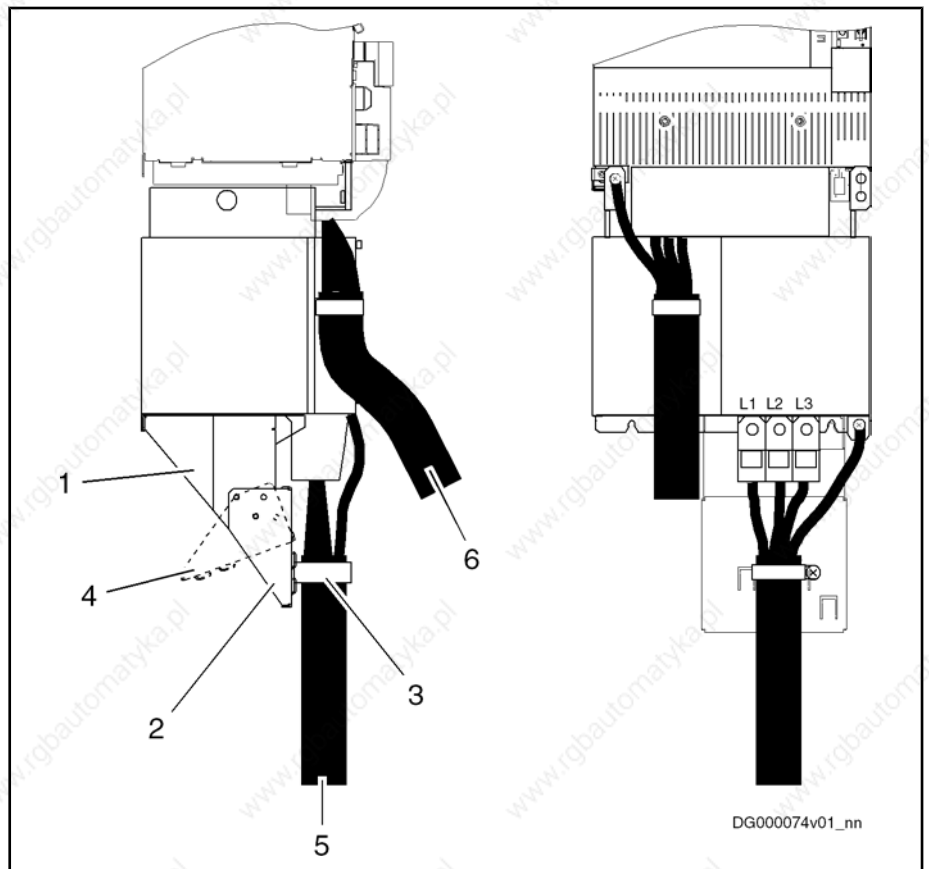

- |   |   |
|---|---|
| 1 | fixing device   |
| 2 | shielding plate   |
| 3 | clip  |
| 4 | different possibilities of mounting the shielding plate, according to cable routing |
| 5 | power supply cable  |
| 6 | motor cable   |

Fig. 14-54: HAS02.1-009 at bottom of mains filter (rated current 146 A)

**Mounting**

1. By means of supplied screws, fasten fixing device to bottom of drive controller.
2. Fix shielding plate to fixing device according to desired motor cable routing.
3. Fix shield of cable to shielding plate with appropriate clip.



The shield terminals must not be used to provide strain relief.

Accessories in the Drive System Rexroth IndraDrive

## 14.3 HAS03 - Control Cabinet Adapter

### 14.3.1 Type Code

Abbrev. Column	1	2	3	4	5	6	7	8	9	0	1	2	3	4	5	6	7	8	9
Example:	H	A	S	0	3	.	1	-	0	0	2	-	N	N	N	-	N	N	
<b>1. Product</b>																			
1.1 Accessories	IndraDrive ... = HAS																		
<b>2. Line</b>																			
2.1 Control cabinet adapter	= 03																		
<b>3. Design</b>																			
3.1 1 .....	= 1																		
<b>4. Device assignment (Number of bolt)</b>																			
4.1 HCS02.1E-W0012 .....	= 002																		
4.2 HCS02.1E-W0028 .....	= 002																		
4.3 HLB01.1C-01K0-N06R0-A-007-NNNN	= 002																		
4.4 HLC01.1C-01M0-A-007-NNNN	= 002																		
4.5 HLC01.1C-02M4-A-007-NNNN	= 002																		
4.6 HCS02.1E-W0054 .....	= 004																		
4.7 HCS02.1E-W0070 .....	= 004																		
<b>5. Other feature</b>																			
5.1 none .....	= NNN																		
<b>6. Other design</b>																			
6.1 none .....	= NN																		

DT000005v01\_en.fh

Fig. 14-55: Type code HAS03.1

### 14.3.2 Usage

The control cabinet adapter is used to compensate different mounting depths of drive controllers HCS02.1E and HLC01.1C and HMS01 / HMD01 when mounted to a common mounting surface.

## Accessories in the Drive System Rexroth IndraDrive

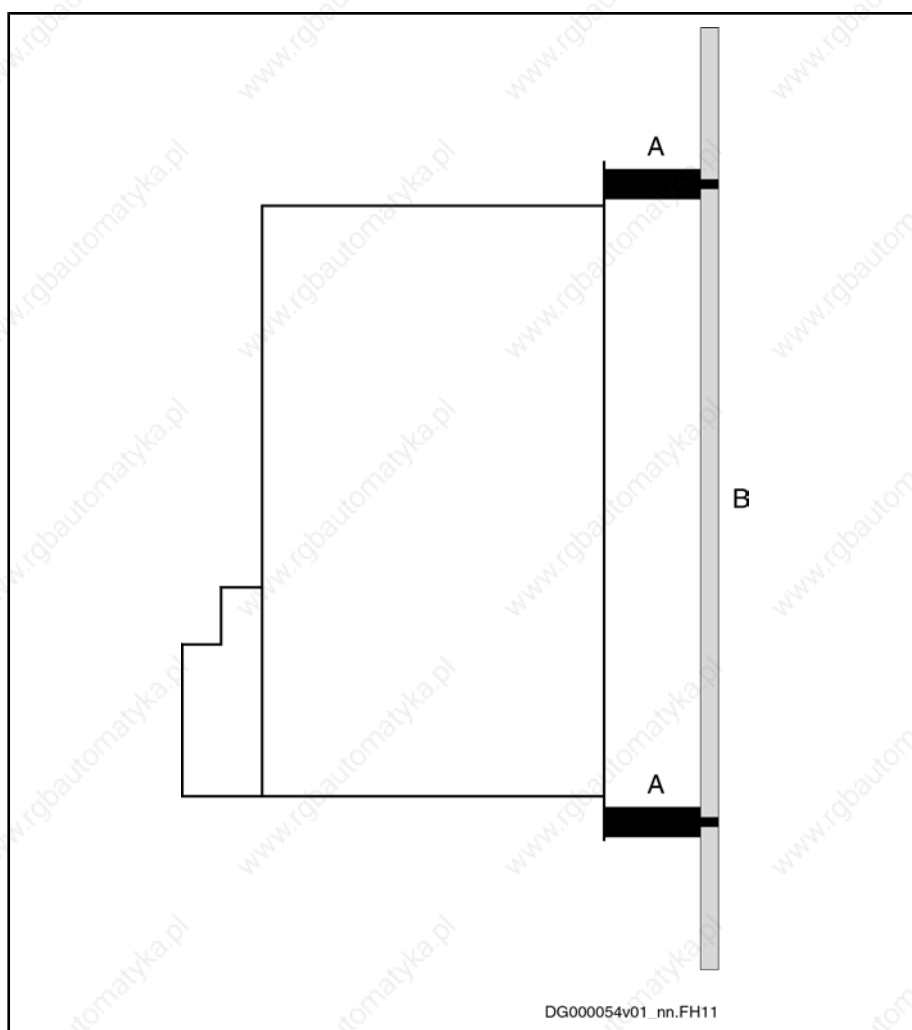

A control cabinet adapter  
B mounting surface in control cabinet

Fig. 14-56: How to use the control cabinet adapters



Observe the maximum allowed **tightening torque** of **6 Nm** at HAS03.



Mechanical stability of the adapted device requires a rigid connection via DC bus rails to a neighboring device without adapter.

- Do not operate HAS03 without neighboring device.
- Mount HAS03 to bare metal mounting plate.

### 14.3.3 Assignment HAS03 Accessories

See section "Type Code (Device Assignment)".

### 14.3.4 Scope of Supply

**Scope of Supply** For the scope of supply and the parts of HAS03, see the corresponding accompanying note.

Accessories in the Drive System Rexroth IndraDrive



<p>Made in Germany 109-1253-4825-01</p> <div style="text-align: right;">  </div> <h2 style="text-align: center; margin: 20px 0;">HAS03.1-002-NNN-NN</h2> <div style="text-align: center;">                   R911308567             </div> <table border="1" style="width: 100%; border-collapse: collapse; margin-top: 20px;"> <tr> <td style="width: 10%; text-align: center;">2</td> <td style="width: 70%;">ABSTANDBOLZEN BM 6,0X 57,0 SW19,0 ST-ZN</td> <td style="width: 20%; text-align: center;">R911309313</td> </tr> <tr> <td style="text-align: center;"><b>Stck</b></td> <td style="text-align: center;"><b>Benennung</b></td> <td style="text-align: center;"><b>MN</b></td> </tr> </table>	2	ABSTANDBOLZEN BM 6,0X 57,0 SW19,0 ST-ZN	R911309313	<b>Stck</b>	<b>Benennung</b>	<b>MN</b>	<table border="1" style="width: 100%; border-collapse: collapse;"> <tr> <th colspan="3" style="text-align: center;">BEIPACKZETTEL HAS03.1-002-NNN-NN</th> </tr> <tr> <td style="width: 10%; text-align: center;">Stck</td> <td style="width: 60%; text-align: center;">Benennung</td> <td style="width: 30%; text-align: center;">MN</td> </tr> <tr> <td style="text-align: center;">2</td> <td style="text-align: center;">ABSTANDBOLZEN BM 6,0X 57,0 SW19,0 ST-ZN</td> <td style="text-align: center;">R911309313</td> </tr> </table> <div style="text-align: center; margin: 20px 0;">  </div> <p style="text-align: right; margin-right: 20px;">1:2</p> <table border="1" style="width: 100%; border-collapse: collapse; margin-top: 20px;"> <tr> <td style="width: 20%;">Datum</td> <td style="width: 20%;">2004-08-04</td> <td style="width: 60%;">Benennung</td> </tr> <tr> <td>Name</td> <td>Hirt</td> <td>BEIPACKZETTEL HAS03.1-002-NNN-NN</td> </tr> <tr> <td>Material-Nr.</td> <td>R911308566</td> <td>Zeich-Nr. 109-1253-4235-01</td> </tr> <tr> <td>Datei</td> <td>DB173400</td> <td>Ers.durch .. AEM-Nr. 5-011323</td> </tr> </table>	BEIPACKZETTEL HAS03.1-002-NNN-NN			Stck	Benennung	MN	2	ABSTANDBOLZEN BM 6,0X 57,0 SW19,0 ST-ZN	R911309313	Datum	2004-08-04	Benennung	Name	Hirt	BEIPACKZETTEL HAS03.1-002-NNN-NN	Material-Nr.	R911308566	Zeich-Nr. 109-1253-4235-01	Datei	DB173400	Ers.durch .. AEM-Nr. 5-011323
2	ABSTANDBOLZEN BM 6,0X 57,0 SW19,0 ST-ZN	R911309313																										
<b>Stck</b>	<b>Benennung</b>	<b>MN</b>																										
BEIPACKZETTEL HAS03.1-002-NNN-NN																												
Stck	Benennung	MN																										
2	ABSTANDBOLZEN BM 6,0X 57,0 SW19,0 ST-ZN	R911309313																										
Datum	2004-08-04	Benennung																										
Name	Hirt	BEIPACKZETTEL HAS03.1-002-NNN-NN																										
Material-Nr.	R911308566	Zeich-Nr. 109-1253-4235-01																										
Datei	DB173400	Ers.durch .. AEM-Nr. 5-011323																										

Fig.14-57: Accompanying note



Accessories in the Drive System Rexroth IndraDrive

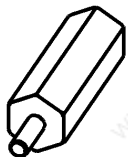

<p>Made in Germany 109-1253-4826-01</p> <div style="text-align: right;">  </div> <h2 style="text-align: center; margin: 20px 0;">HAS03.1-004-NNN-NN</h2> <div style="text-align: center;">  <p>R 9 1 1 3 0 8 5 6 8</p> </div>		<table border="1" style="width: 100%; border-collapse: collapse;"> <tr> <th colspan="3" style="text-align: center;">BEIPACKZETTEL HAS03.1-004-NNN-NN</th> </tr> <tr> <th style="width: 10%;">Stck</th> <th style="width: 70%;">Benennung</th> <th style="width: 20%;">MN</th> </tr> <tr> <td style="text-align: center;">4</td> <td>ABSTANDSBOLZEN BM 6,0X 57,0 SW19,0 ST-ZN</td> <td style="text-align: center;">R911309313</td> </tr> <tr> <td colspan="3" style="text-align: center;"> <div style="display: flex; justify-content: space-around; align-items: center;"> <div style="writing-mode: vertical-rl; transform: rotate(180deg); font-size: small;">08172119</div>  <div style="text-align: right;">1:2</div> </div> </td> </tr> <tr> <td colspan="3" style="height: 150px;"></td> </tr> <tr> <td colspan="3" style="text-align: center;"> <table border="1" style="width: 100%; border-collapse: collapse;"> <tr> <td style="width: 10%; text-align: center;">4</td> <td style="width: 70%;">ABSTANDSBOLZEN BM 6,0X 57,0 SW19,0 ST-ZN</td> <td style="width: 20%; text-align: center;">R911309313</td> </tr> <tr> <th style="text-align: center;">Stck</th> <th style="text-align: center;">Benennung</th> <th style="text-align: center;">MN</th> </tr> </table> </td> </tr> </table>		BEIPACKZETTEL HAS03.1-004-NNN-NN			Stck	Benennung	MN	4	ABSTANDSBOLZEN BM 6,0X 57,0 SW19,0 ST-ZN	R911309313	<div style="display: flex; justify-content: space-around; align-items: center;"> <div style="writing-mode: vertical-rl; transform: rotate(180deg); font-size: small;">08172119</div>  <div style="text-align: right;">1:2</div> </div>						<table border="1" style="width: 100%; border-collapse: collapse;"> <tr> <td style="width: 10%; text-align: center;">4</td> <td style="width: 70%;">ABSTANDSBOLZEN BM 6,0X 57,0 SW19,0 ST-ZN</td> <td style="width: 20%; text-align: center;">R911309313</td> </tr> <tr> <th style="text-align: center;">Stck</th> <th style="text-align: center;">Benennung</th> <th style="text-align: center;">MN</th> </tr> </table>			4	ABSTANDSBOLZEN BM 6,0X 57,0 SW19,0 ST-ZN	R911309313	Stck	Benennung	MN
BEIPACKZETTEL HAS03.1-004-NNN-NN																											
Stck	Benennung	MN																									
4	ABSTANDSBOLZEN BM 6,0X 57,0 SW19,0 ST-ZN	R911309313																									
<div style="display: flex; justify-content: space-around; align-items: center;"> <div style="writing-mode: vertical-rl; transform: rotate(180deg); font-size: small;">08172119</div>  <div style="text-align: right;">1:2</div> </div>																											
<table border="1" style="width: 100%; border-collapse: collapse;"> <tr> <td style="width: 10%; text-align: center;">4</td> <td style="width: 70%;">ABSTANDSBOLZEN BM 6,0X 57,0 SW19,0 ST-ZN</td> <td style="width: 20%; text-align: center;">R911309313</td> </tr> <tr> <th style="text-align: center;">Stck</th> <th style="text-align: center;">Benennung</th> <th style="text-align: center;">MN</th> </tr> </table>			4	ABSTANDSBOLZEN BM 6,0X 57,0 SW19,0 ST-ZN	R911309313	Stck	Benennung	MN																			
4	ABSTANDSBOLZEN BM 6,0X 57,0 SW19,0 ST-ZN	R911309313																									
Stck	Benennung	MN																									
<div style="border: 1px solid black; height: 300px; width: 100%;"></div>		<table border="1" style="width: 100%; border-collapse: collapse;"> <tr> <td style="width: 15%;">Datum</td> <td style="width: 35%;">2004-08-04</td> <td style="width: 20%;">Benennung</td> <td style="width: 30%;">BEIPACKZETTEL HAS03.1-004-NNN-NN</td> </tr> <tr> <td>Name</td> <td>Hirt</td> <td colspan="2"></td> </tr> <tr> <td>Material-Nr.</td> <td>R911308568</td> <td>Zeich-Nr.</td> <td>109-1253-4236-01</td> </tr> <tr> <td>Datei</td> <td>08173398</td> <td>Ers.durch</td> <td>...</td> </tr> <tr> <td colspan="2"></td> <td>AEM-Nr.</td> <td>5-011323</td> </tr> </table>		Datum	2004-08-04	Benennung	BEIPACKZETTEL HAS03.1-004-NNN-NN	Name	Hirt			Material-Nr.	R911308568	Zeich-Nr.	109-1253-4236-01	Datei	08173398	Ers.durch	...			AEM-Nr.	5-011323				
Datum	2004-08-04	Benennung	BEIPACKZETTEL HAS03.1-004-NNN-NN																								
Name	Hirt																										
Material-Nr.	R911308568	Zeich-Nr.	109-1253-4236-01																								
Datei	08173398	Ers.durch	...																								
		AEM-Nr.	5-011323																								

Fig. 14-58: Accompanying note

Accessories in the Drive System Rexroth IndraDrive

## 14.4 Capacitor HAS04

### 14.4.1 General Information

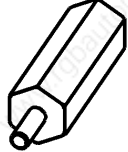
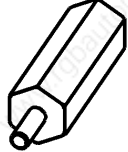
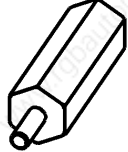
Capacitors from the DC bus connections L+ and L- against housing.

### 14.4.2 Type Code

Abbrev. Column	1	2	3	4	5	6	7	8	9	10	11	12	13	14	15	16	17	18	19
Example:	H	A	S	0	4	.	1	-	0	0	1	-	N	N	N	-	N	N	

<b>1. Product</b>	
1.1 Accessories	IndraDrive ... = HAS
<b>2. Line</b>	
2.1 Capacitor	..... = 04
<b>3. Design</b>	
3.1 1	..... = 1
<b>4. Capacitor</b>	
4.1 2 x 470 nF (HCS02.x)	..... = 001
4.2 2 x 470 nF (HCS03.x)	..... = 002
<b>5. Other feature</b>	
5.1 none	..... = NNN
<b>6. Other design</b>	
6.1 none	..... = NN

DT000006v01\_en.fh

Fig. 14-59: Type code HAS04.1



Using the HAS04 accessories requires additional mounting clearance at the drive controller.

Observe the dimensions of HAS04.

### 14.4.3 Usage

The HAS04 accessories are used to

- operate HCS02 and HCS03 drive controllers at the HNF01.1 mains filter
- operate HMS01 drive controllers at HCS02 and HCS03 drive controllers

HAS04 type	Usage
HAS04.1-001-NNN-NN	at DC bus connections of HCS02 drive controllers
HAS04.1-002-NNN-NN	at DC bus connections of HCS03 drive controllers

Fig. 14-60: HAS04 type

## Accessories in the Drive System Rexroth IndraDrive

**14.4.4 Assignment**

Device (type)	HAS04.1	
	-001	-002
HCS02.1E-W0028	■	-
HCS02.1E-W0054	■	-
HCS02.1E-W0070	■	-
HCS03.1E-W0070	-	■
HCS03.1E-W0100	-	■
HCS03.1E-W0150	-	■
HCS03.1E-W0210	-	■

Fig. 14-61: Assignment HAS04 accessory

**14.4.5 Scope of Supply**

The HAS04 accessories are available as an option, they are not part of the standard scope of supply.

Accessories in the Drive System Rexroth IndraDrive

Made in Germany  
109-1228-4S05-00



## HAS04.1-001-NNN-NN



R911309268

3	SCHR-LIN-M 6,0X12,0-K-8.8-ISO7045-ZN-Z41	R911252551
1	SCHIENE-VERBINDUNG HAS01.1-150-072	R911306692
1	BGR HAS04.1-001-NNN-NN	R911309270
Stck	Benennung	MN

**BEIPACKZETTEL HAS04.1-001-NNN-NN**

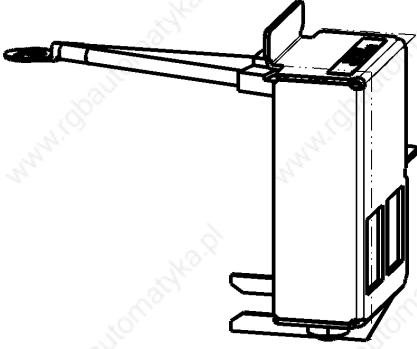
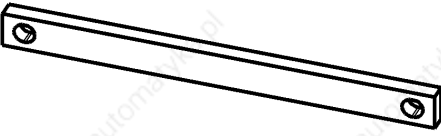
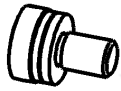
Stck	Benennung	MN
1	BGR HAS04.1-001-NNN-NN	R911309270
 <p style="text-align: right;">1:2</p>		
1	SCHIENE-VERBINDUNG HAS01.1-150-072	R911306692
 <p style="text-align: right;">1:2</p>		
3	SCHR-LIN-M 6,0X12,0-K-8.8-ISO7045-ZN-Z41	R911252551
 <p style="text-align: right;">1:1</p>		

Datum	2004-10-15	Benennung
Name	Razzo	BEIPACKZETTEL HAS04.1-001-NNN-NN
Material-Nr.	R911309316	Zeich-Nr. 109-1228-4236-01
Datei	DB177206	Ers.durch 109-1228-4236-00 AEM-Nr. ohae

Fig. 14-62: Accompanying note HAS04.1-001

Accessories in the Drive System Rexroth IndraDrive

Made in Germany  
109-1253-4847-00

**Rexroth  
Bosch Group**

# HAS04.1-002-NNN-NN



R911315348

1	SCHR-LIN-M 6, 0X25, 0-K-8. 8-ISO7045-ZN-Z41	R911276873
2	LZE-PU0014-GY033-KA30S4/XXXX-SG27H9/XXXX	R911315727
2	LZE-PU0014-GY020-KA30S4/XXXX-SG27H9/XXXX	R911315725
1	BGR HAS04.1-002-NNN-NN	R911315347
Stck	Benennung	MN

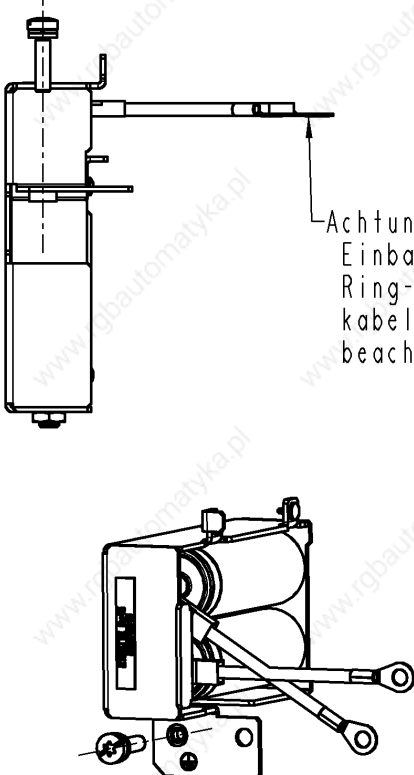

Achtung !  
Einbaulage des  
Ring-  
kabelschuhs  
beachten !!!

BEIPACKZETTEL HAS04.1-002-NNN-NN

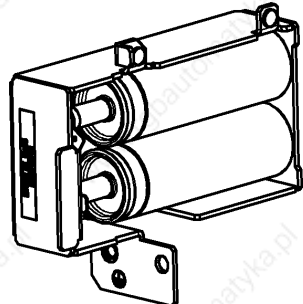
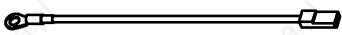
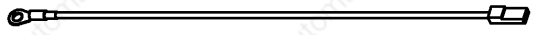
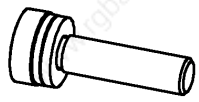
Stck	Benennung	MN
1	BGR HAS04.1-002-NNN-NN	R911315347
		
		2:5
2	LZE-PU0014-GY020-KA30S4/XXXX-SG27H9/XXXX	R911315725
		
		1:4
2	LZE-PU0014-GY033-KA30S4/XXXX-SG27H9/XXXX	R911315727
		
		1:4
1	SCHR-LIN-M 6, 0X25, 0-K-8. 8-ISO7045-ZN-Z41	R911276873
		
		1:1

Datum	2005-10-06	Benennung	BEIPACKZETTEL HAS04.1-002-NNN-NN	
Name	rainhirt	Zeich-Nr.	109-1253-4281-00	
Material-Nr.	R911315349	Ers.durch	..	AEM-Nr. ..
Datei	DB192241			

Fig. 14-63: Accompanying note HAS04.1-002

Accessories in the Drive System Rexroth IndraDrive

### 14.4.6 Capacitor

Connection HAS04

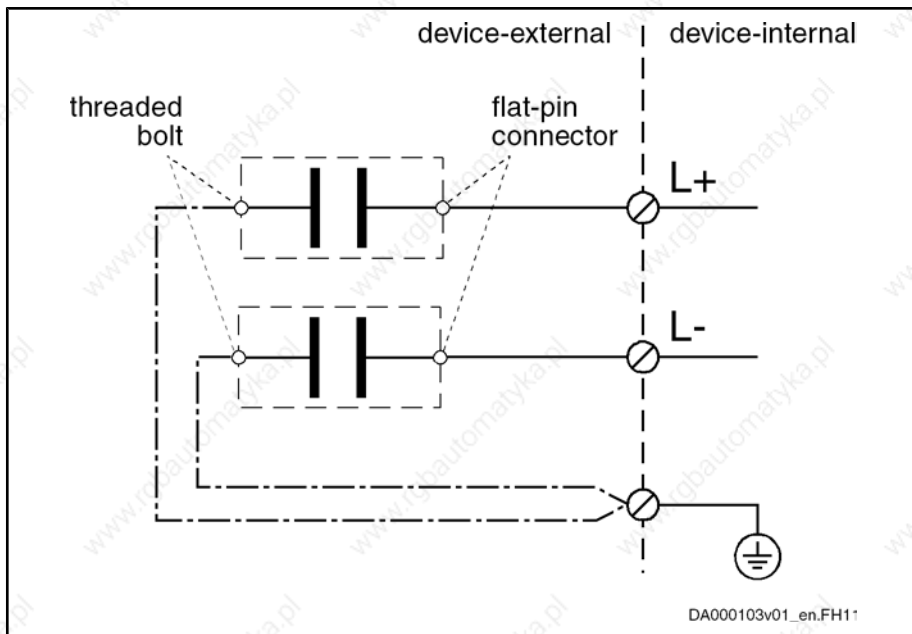

Fig. 14-64: Connection HAS04

### 14.4.7 Mounting Dimensions

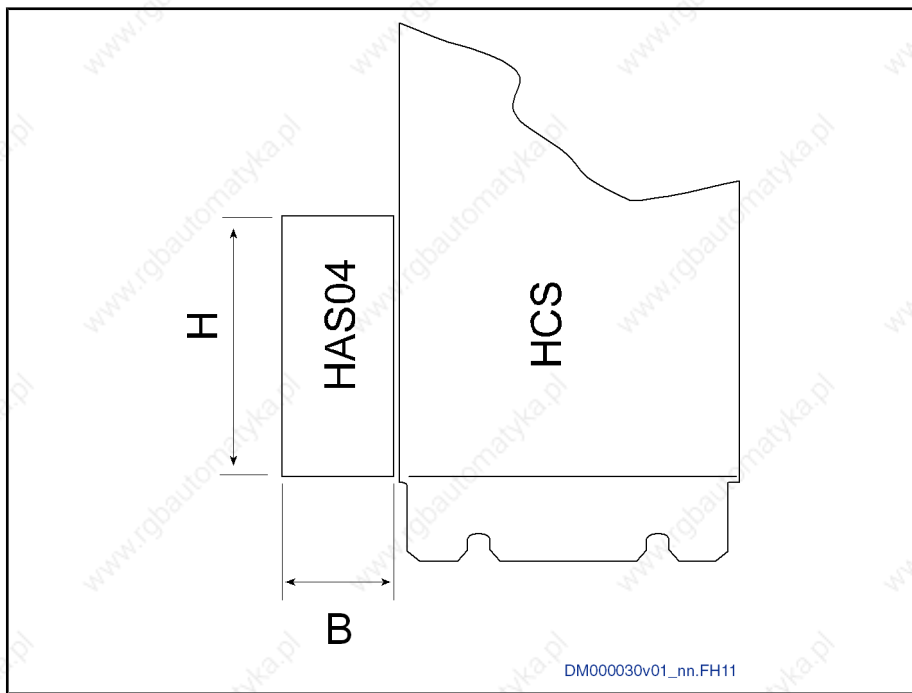

Fig. 14-65: Mounting dimensions HAS04

Device	Min. mounting width B [mm]	Device height H [mm]	Device depth [mm]
HAS04.1-001	30	75	< 150
HAS04.1-002	40	75	< 150

Fig. 14-66: Mounting dimensions

## 14.4.8 Mounting the HAS04.1-001 Accessories



**WARNING**

**Dangerous contact voltage at device housing! Lethal electric shock!**

Connect HMx01 drive controllers to the HCS02 drive controller by means of bus bar 2 (see figure below). Bus bar 2 replaces the equipment grounding connection 3 at HMx01 (see figure below) to the equipment grounding system.

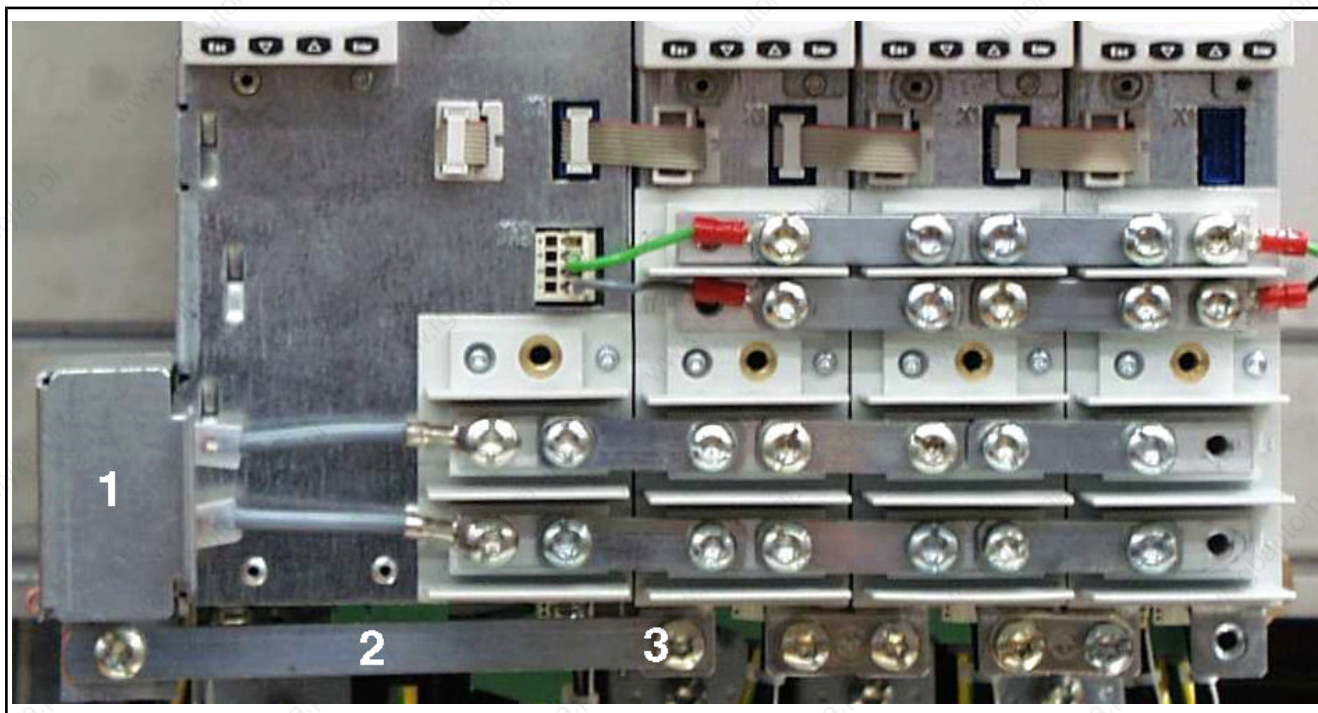

- 1 mounted HAS04.1-001 accessories with connection to L+ and L-
- 2 mounted bus bar
- 3 equipment grounding connection at HMx01

*Fig. 14-67: HAS04.1-001 at drive system HCS02 with HMx01 without touch guard mounted*



### Accessories in the Drive System Rexroth IndraDrive



- 1 mounted HAS04.1-001 accessories
- 2 mounted bus bar

Fig. 14-68: HAS04.1-001 at drive system HCS02 with HMx01 with touch guard mounted

## 14.4.9 Mounting the HAS04.1-002 Accessories



**WARNING**

**Dangerous contact voltage at device housing! Lethal electric shock!**

Connect the HAS04.1-002 accessories to drive controller HCS03 via the joint bar (see figure below).

Accessories in the Drive System Rexroth IndraDrive

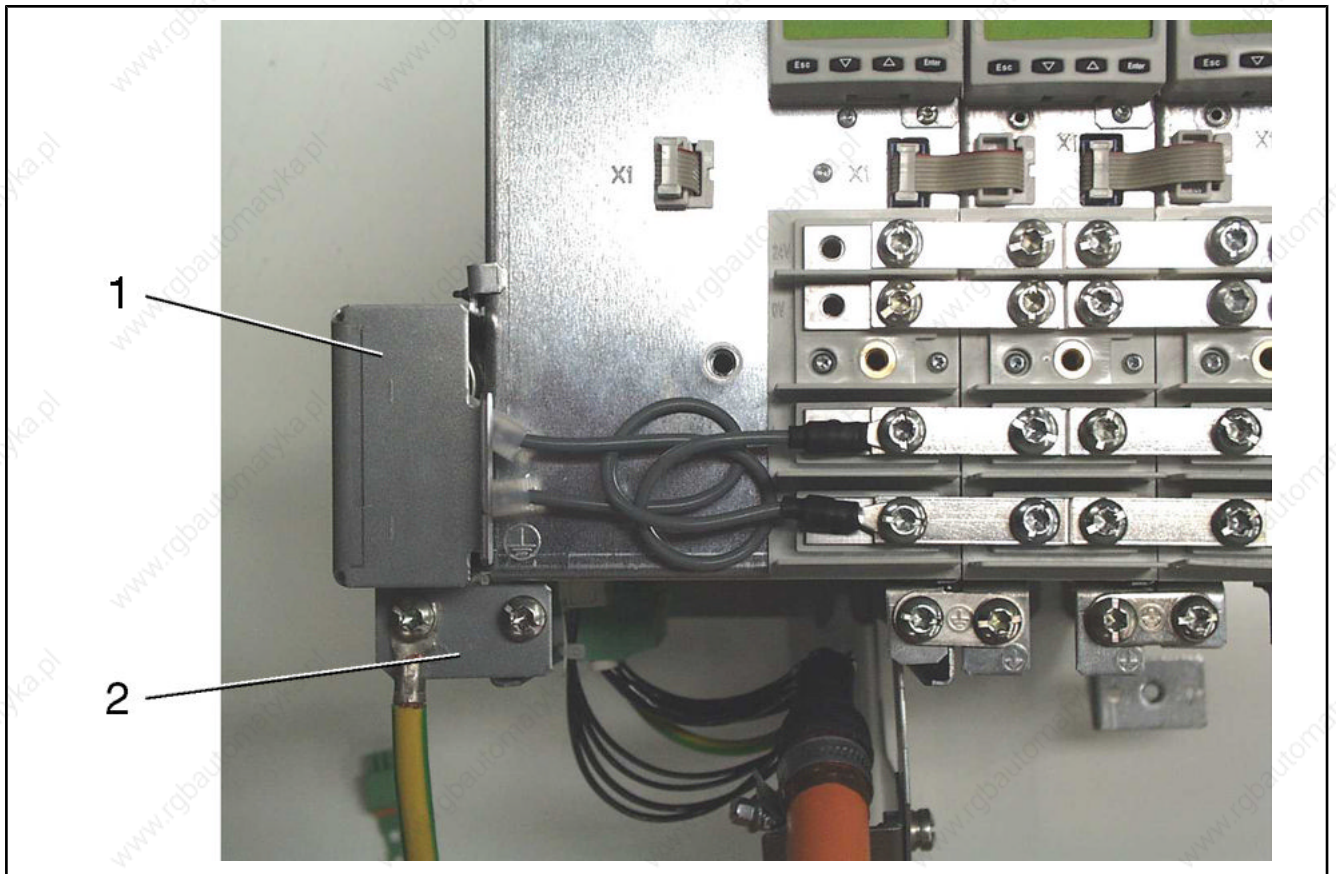

- 1 mounted HAS04.1-002 accessories with connection to L+ and L- joint bar
- 2

Fig. 14-69: HAS04.1-002 at drive system HCS03.1E-W0070, -W0100, -W0150 with HMx01 without touch guard mounted

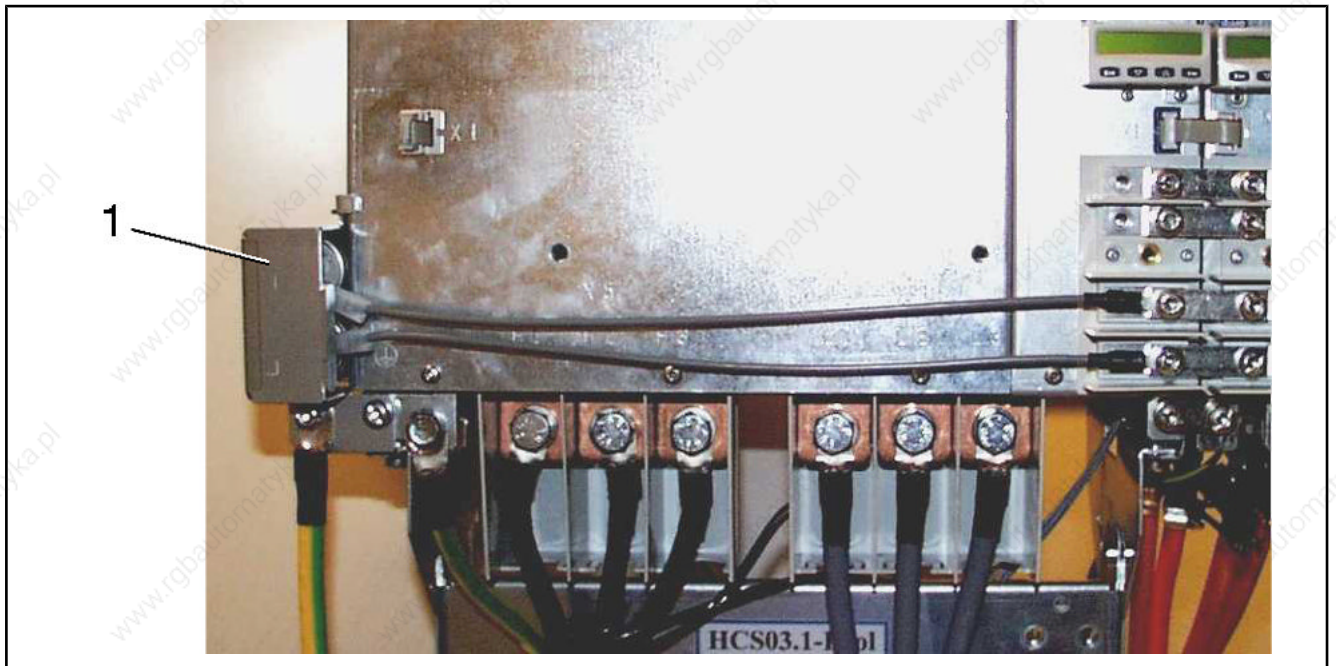

1 mounted HAS04.1-002 accessories with connection to L+ and L-  
Fig. 14-70: HAS04.1-002 at drive system HCS03.1E-W0210 with HMx01 without touch guard mounted



Accessories in the Drive System Rexroth IndraDrive

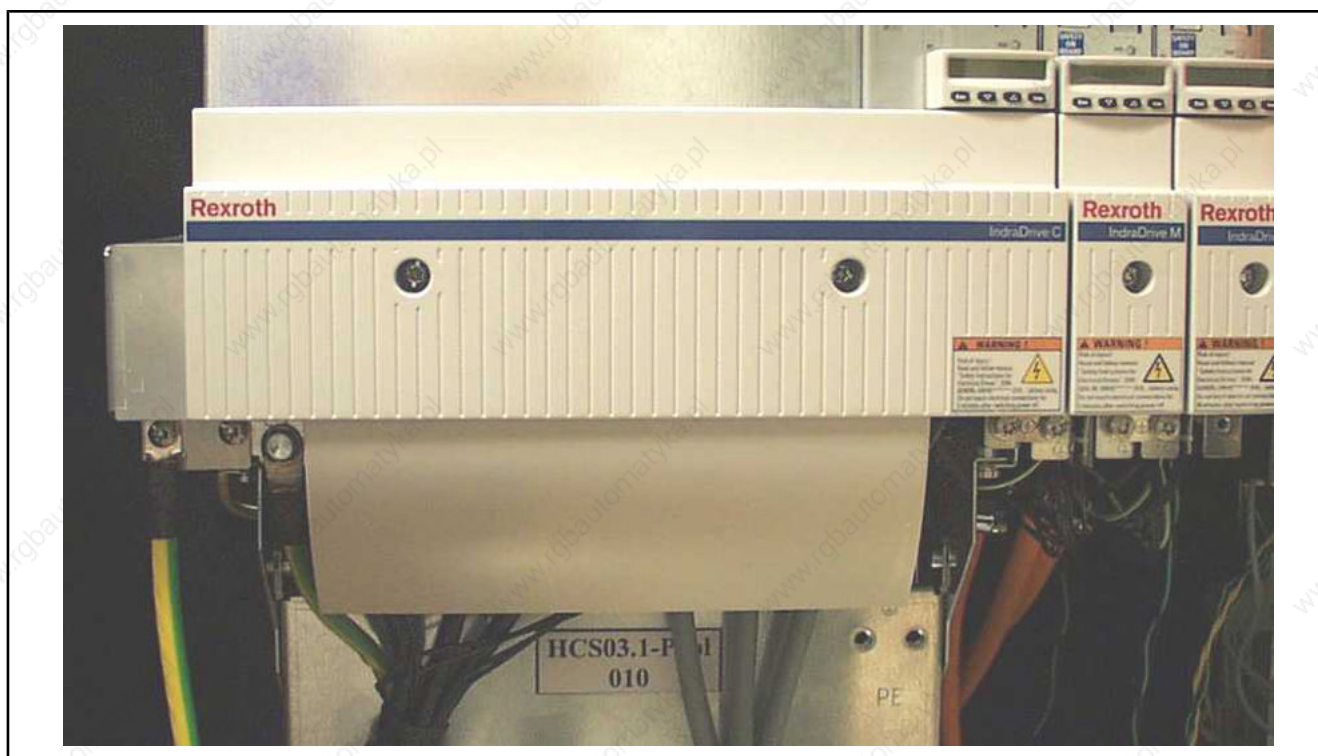

Fig.14-71: HAS04.1-002 at drive system HCS03 with HMx01 with touch guard mounted

## 14.5 Accessories HAS05

### 14.5.1 Overview of Types

The product line HAS05 includes:

- cables
- connectors
- adapters

HAS05 type	Brief description / usage
HAS05.1-001-NNN-NN	adapter for mains and motor connection is used for electrical connection between output filter HMF01.1A-D0K2-D0045 and HCS03.1E-W0070, as well as between mains filter HNK01.1A-A075-E0050 and HCS03.1E-W0070
HAS05.1-002-NNN-NN	extension is used for electrical connection between mains filter HNK01.1A-A075-E0050 and HCS03.1E-W0070, if an output filter has been mounted between HCS03.1 and mains filter
HAS05.1-003-NNN-NN	signal level converter encoder emulation increases voltage level at output of optional module MEM (encoder emulation) to voltage range 5 ... 30 V

## Accessories in the Drive System Rexroth IndraDrive

HAS05 type	Brief description / usage
HAS05.1-004-NNL-NN HAS05.1-004-NNR-NN	adapter DC bus connection with this accessory, you can wire several systems of drive controllers with greater cross sections at DC bus connections L+ and L- NNL: outgoing direction "left" NNR: outgoing direction "right"
HAS05.1-005-NNN-NN	signal level converter RS232/RS485 converts serial interface of control sections from RS232 standard to RS485 standard
HAS05.1-006-NNN-NN (preliminary)	adapter for controlling motor holding brake
HAS05.1-007-NNL-NN (preliminary) HAS05.1-007-NNR-NN (preliminary)	adapter from D-Sub to terminal connector universal adapter for safety technology for easier X41 wiring of 2nd channel NNL: for mounting to double-axis control sections CDB01 at OP ST1 NNR: for mounting to double-axis control sections CDB01 at OP ST2
HAS05.1-008-NNN-NN	adapter for connecting two cables with this accessory, you can connect 2 ring cable lugs each at connections A1, A2 and A3 of X5 (motor connection)

Fig. 14-72: HAS05 type

## 14.5.2 Type Code



The following figure illustrates the basic structure of the type code. Our sales representative will help you with the current status of available versions.

Accessories in the Drive System Rexroth IndraDrive

Abbrev. Column	→	1	2	3	4	5	6	7	8	9	0	1	2	3	4	5	6	7	8	9	0	1	2	3	4	5	6	7	8	9	0	1	2	3	4	5	6	7	8	9				
Example:		H	A	S	0	5	.	1	-	0	0	1	-	N	N	N	-	N	N																									

**Product**  
HAS..... = HAS

**Line**  
Cable, connectors and adapter..... = 05

**Design**  
1..... = 1

**Assignment**

**Adapter**  
 HCS03.1E-W0070 ..... = 001  
 HMF01.1...0070 ..... = 002  
 Level emulation Encoder emulation = 003  
 DC bus, 2 x 50 mm<sup>2</sup>. ..... = 004  
 RS232/RS485 converter ..... = 005  
 Brake module ..... = 006  
 X41 adapter ..... = 007  
 Motor connection, 2 x 16 mm<sup>2</sup> = 008

**Other features**  
 none ..... = NNN  
 Fitting direction : on both sides ..... = NNB  
 Fitting direction : lefthand ..... = NNL  
 Fitting direction : righthand ..... = NNR

**Other design**  
 None ..... = NN

**zu Feld Zuordnung**

Adapter: "001"



Adapter: "002"



Adapter: "003"



Adapter: "004"

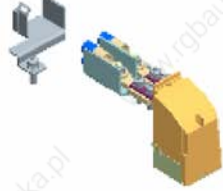

Adapter: "005"



Adapter: "006"

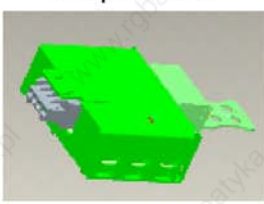

Adapter: "007"

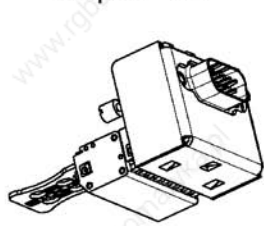

Adapter: "008"

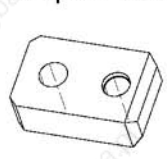

DT000015v01\_en.FH11

Fig.14-73: Type code HAS05.1

### 14.5.3 HAS05.1-001, Adapter for Mains and Motor Connection

#### Brief Description and Usage

**Brief Description** The accessory HAS05.1-001 brings the mains and motor connections from the bottom of the device to the front of an HCS03.1-W0070.

Accessories in the Drive System Rexroth IndraDrive

You need this adapter when additional components are mounted to HCS03.1E-W0070 in order to connect them to the mains and motor input.

**Assignment** HAS05.1-001 can be used at the following drive controllers:

Device	HAS05.1-001
HCS03.1E-W0070	■

Fig. 14-74: Assignment accessory HAS05.1-001

**Scope of Supply** Order this accessory as a separate item. It is not part of the scope of supply of the device.

Parts of the accessory: see accompanying note

**Parts of HAS05.1-001**

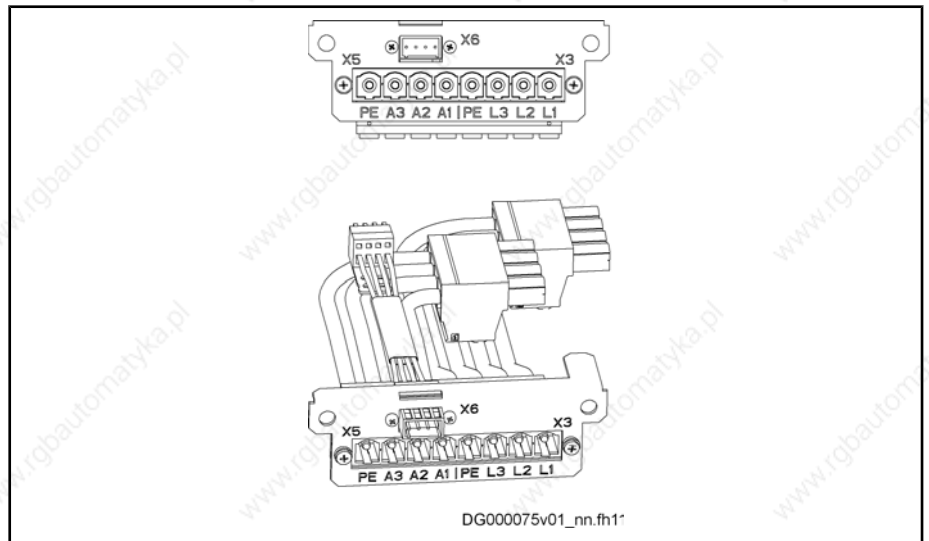

Fig. 14-75: Parts of HAS05.1-001

**Technical Data**

**Connection, Mounting Dimensions**

**Allowed Cross Sections** The accessory HAS05.1 has been dimensioned to insert lines with ferrules in it.

	Unit	HAS05.1-001
allowed connection cross section stranded wire	mm <sup>2</sup>	16
allowed connection cross section stranded wire	AWG	6

Fig. 14-76: Connection cross section HAS05.1-001

**Mounting Dimensions** The mounted adapter remains within the outer housing dimensions of the involved components HMF and HCS03.

- Connection**
- **HMF01**  
Connect input of output filter HMF01 to X5 at HAS05.1-001 (motor output of HCS03).
  - **HNK01**  
Connect output of mains filter HNK01 to X3 at HAS05.1-001 (mains input of HCS03).

**Examples of Installation** Mounted accessory

Accessories in the Drive System Rexroth IndraDrive

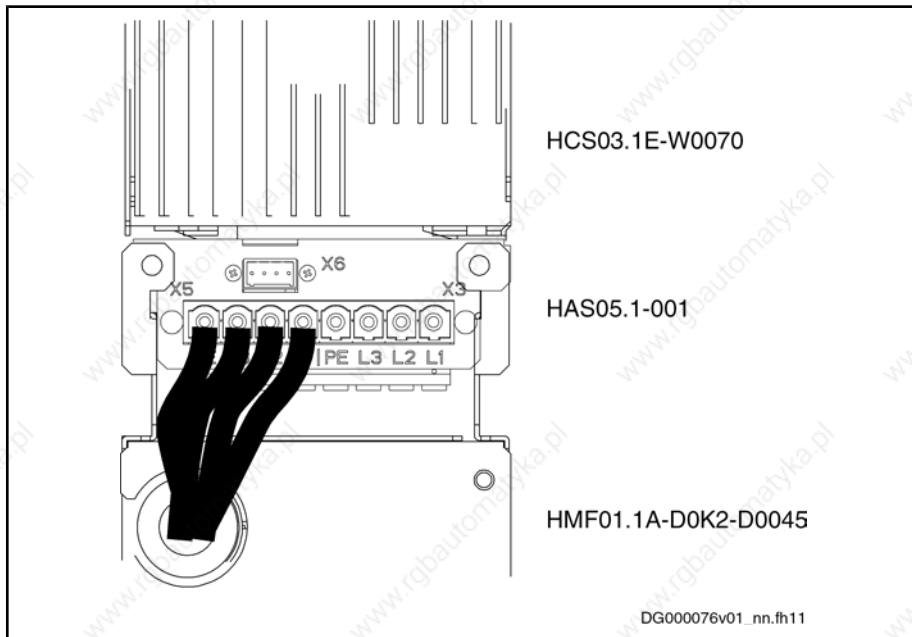

Fig. 14-77: Arrangement HCS03 / HAS05.1-001 / HMF01

### 14.5.4 HAS05.1-002, Extension

#### Brief Description and Usage

**Brief Description** The accessory HAS05.1-002 is an extension which connects the output of the HNK01 mains filter to the mains input of HCS03 (X3).

This adapter is required when the additional components HNK01 and HMF01 are mounted to HCS03.1E-W0070. The adapter is not required without HMF01.

**Assignment** HAS05.1-002 can be used at the following drive controllers:

Device	HAS05.1-002
HCS03.1E-W0070 with HNK01 and HMF01	■

Fig. 14-78: Assignment accessory HAS05.1-002

**Scope of Supply** Order this accessory as a separate item. It is not part of the scope of supply of the device.

Parts of the accessory: see accompanying note

**Parts of HAS05.1-002**

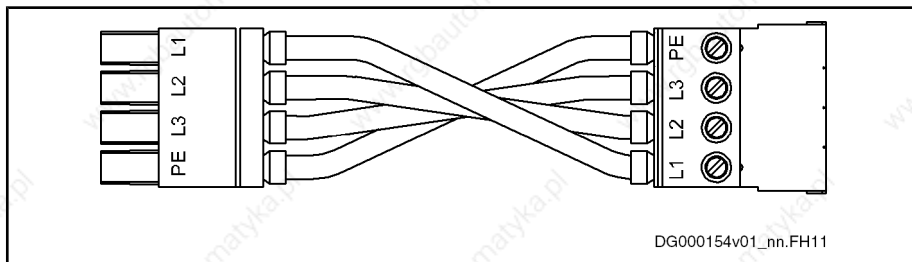

Fig. 14-79: Parts of HAS05.1-002



## 14.5.5 HAS05.1-003, Signal Level Converter Encoder Emulation

### Usage

Accessory	Usage
HAS05.1-003-NNN-NN	adjusts voltage level at output of optional module MEM to voltage range 5–30 V

Fig. 14-80: Usage

### Scope of Supply

#### Scope of Supply

Order this accessory as a separate item. It is not part of the scope of supply of the device.

Parts of the accessory: see accompanying note

### Dimensions

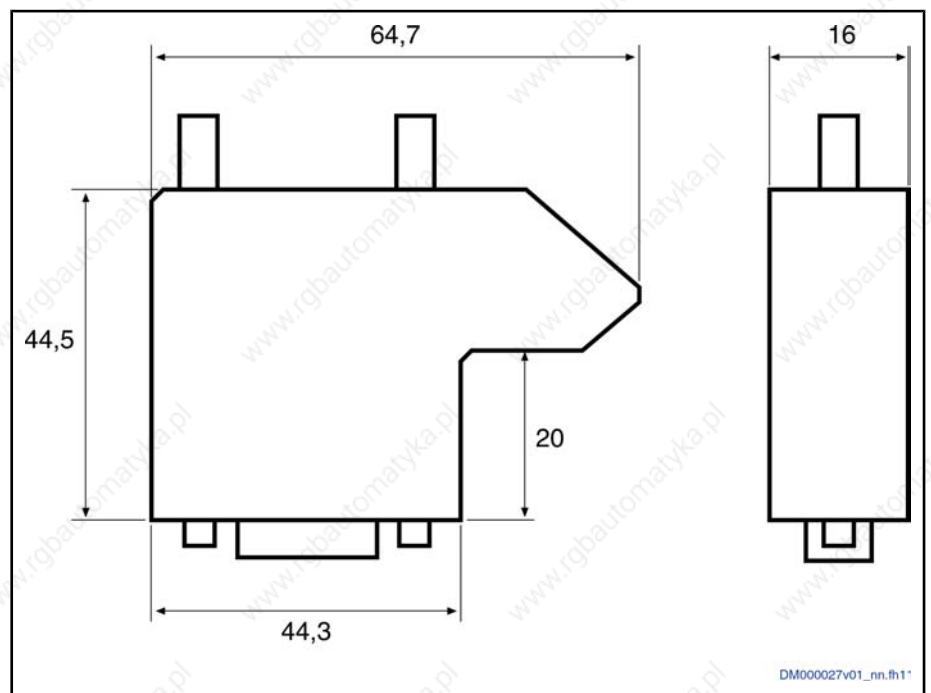
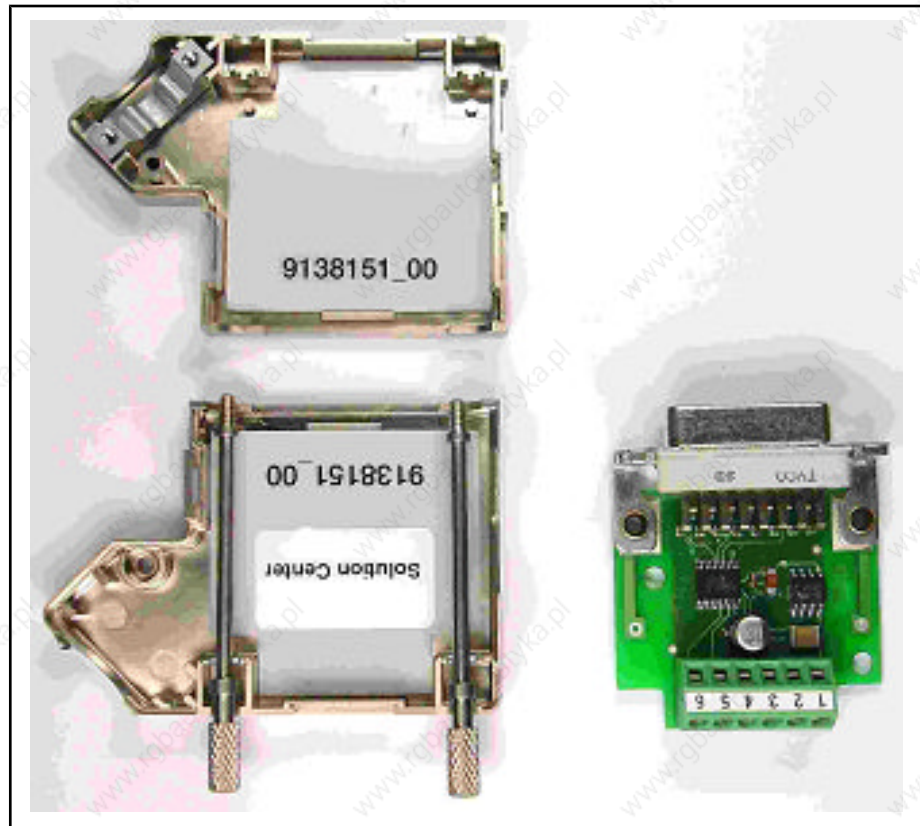

Fig. 14-81: Dimensions HAS05.1-003

## Accessories in the Drive System Rexroth IndraDrive

### Parts



- 1 top shell of connector housing
- 2 bottom shell of connector housing
- 3 electronics circuit board with internal connection point

Fig.14-82: Parts

Accessories in the Drive System Rexroth IndraDrive

Description

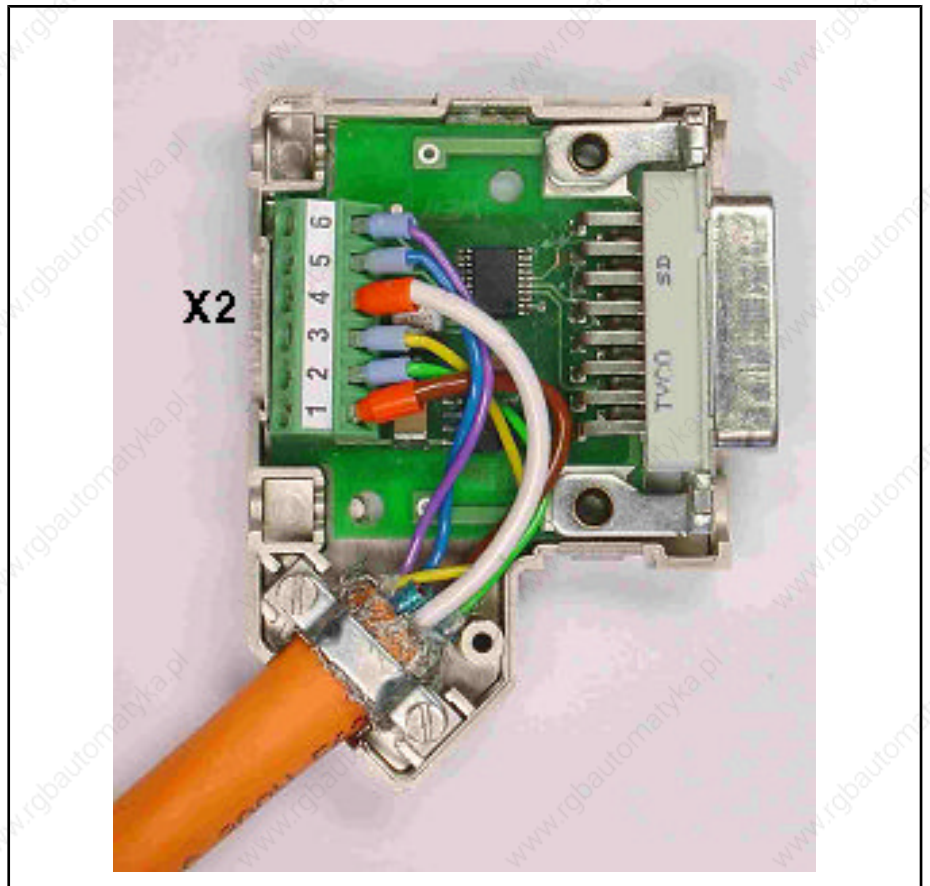

Fig. 14-83: Accessory HAS05.1-003

Connection point	Type	No. of poles	Stranded wire [mm <sup>2</sup> ]
X2	screw terminal block	6	0,14–1,5

Fig. 14-84: Connection

Pin Assignment

Pin	Signal	Function
1	UB	voltage supply for electronics
2	UL	voltage supply for output driver
3	UA2+	incremental encoder track A2
4	0Vext	reference potential
5	UA1+	incremental encoder track A1
6	UA0+	incremental encoder reference track A0
	Shield	connect cable shield to connector housing

Fig. 14-85: Assignment



If the required output voltage UL is greater than 7V, it can be used to supply the electronics (UB), too.

Accessories in the Drive System Rexroth IndraDrive

Electrical Data

Data	Unit	Min.	Typ.	Max.
supply voltage U <sub>L</sub> (output driver)	V	5		30
supply current U <sub>L</sub> (output driver)	mA		16	
supply voltage U <sub>B</sub> (electronics)	V	7		30
supply current U <sub>B</sub> (electronics)	mA		17	
output voltage UA0+, UA1+, UA2+	V			U <sub>L</sub>
allowed output current per output UA0+, UA1+, UA2+	mA			40
output resistance	kOhm			
short circuit protection		included		
overload protection		included, output voltage is reduced		

Fig. 14-86: Supply and outputs

Example of Connection

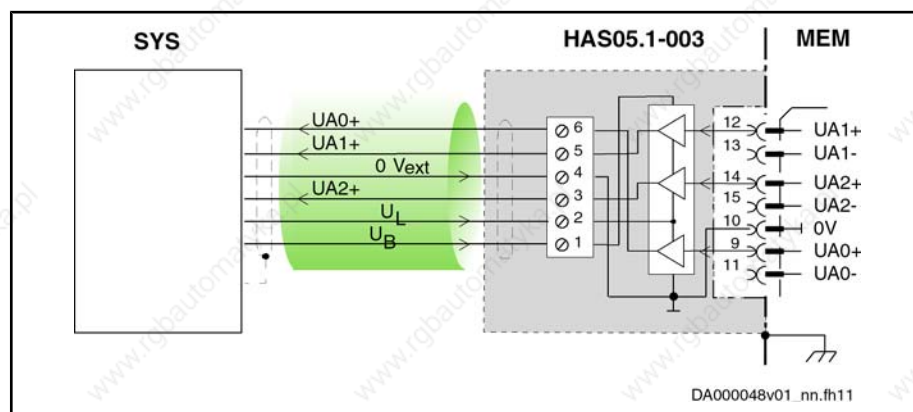

SYS target, e.g. PLC; incremental input, counter or trigger function

Fig. 14-87: Example of connection

### 14.5.6 HAS05.1-004, Adapter DC Bus Connection (Preliminary)

#### Brief Description and Usage

**Brief Description**

The accessory HAS05.1-004-NNR and HAS05.1-004-NNL is an adapter which allows connecting lines with cross sections of up to 2 × 50 mm<sup>2</sup> to the DC bus connections.

It is typically used at the DC bus connections of high-performance supply units and inverters, when these devices have not been arranged directly side by side (e.g. with multiple-line arrangement or with decentralized supply concepts between several control cabinets).

The types "NNR" and "NNL" allow connections with outgoing directions to the right and left (view to front of drive controller).

**Assignment**

The use of the HAS05.1-004 accessory is restricted by the width of the drive controllers:

- NNL: device width is at least 125 mm
- NNR: can be used independently of the device width

## Accessories in the Drive System Rexroth IndraDrive

At devices with a width of 50 mm, the outgoing direction to the left can also be used with the type "NNR".

For devices up to a width of 125 mm and for the outgoing direction to the left, you can fix lines with a **maximum cross section of 1 × 35 mm<sup>2</sup>** (1 ring cable lug) without fixing device (01) and without bar (05) directly at the terminal block (see [picture 4](#)).

The accessory can be used at the following drive controllers:

Device	HAS05.1-004-	
	NNL	NNR
HMV01.1E-W0030, -W0075, -W0120	■	■
HMV01.1R-W0018, -W0065, -W0120	■	■
HMS01.1N: type current < W0110	-	■
HMS01.1N: type current ≥ W0110	■	■
HMD01.1N-W0012, -W0020, -W0036	-	■
HCS03.1E: type current ≥ W0070	■	■
HLB01.1D	-	■
HLC01.1D	-	■

Fig. 14-88: Assignment accessory HAS05.1-004

**Scope of Supply**

Order this accessory as a separate item. It is not part of the scope of supply of the device.

Parts of the accessory: see accompanying note

Accessories in the Drive System Rexroth IndraDrive

Accompanying note HAS05.1-004-NNR-NN

Made in Germany  
109-1253-4837-00

**Rexroth  
Bosch Group**

## HAS05.1-004-NNR-NN



R911312154

1	SCHR-EJO-P-KL 40X14	WN1452*-SN-***	R911268139
2	SCHIENE-STROM HAS05.1-004-NNR		R911315873
2	MUTTER-KOM-M 6,0-D12-H06,70 A2-B		R911221473
2	KAB-BIND-D078-B4,8-C085-N220-TR-PA-*****		R911269782
1	BERUEHRUNGSSCHUTZ WINKEL HAS05.1-004-NNR		R911315622
1	BERUEHRUNGSSCHUTZ DECKEL HAS05.1-004-NNR		R911315621
Stck	Benennung		MN

BEIPACKZETTEL HAS05.1-004-NNR-NN			
Stck	Benennung		MN
1	BERUEHRUNGSSCHUTZ DECKEL HAS05.1-004-NNR		R911315621
			
			1:2
1	BERUEHRUNGSSCHUTZ WINKEL HAS05.1-004-NNR		R911315622
			
			1:2

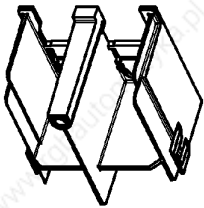
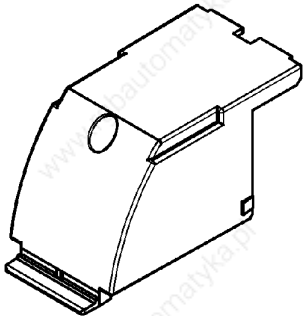
BEIPACKZETTEL HAS05.1-004-NNR-NN			
Stck	Benennung		MN
2	KAB-BIND-D078-B4,8-C085-N220-TR-PA-*****		R911269782
			
			1:4
2	MUTTER-KOM-M 6,0-D12-H06,70 A2-B		R911221473
			
			2:1
2	SCHIENE-STROM HAS05.1-004-NNR		R911315873
			
			1:1
1	SCHR-EJO-P-KL 40X14	WN1452*-SN-***	R911268139
			
			2:1

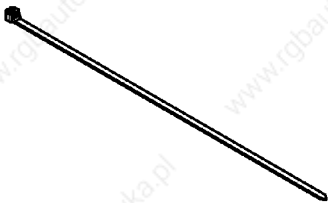
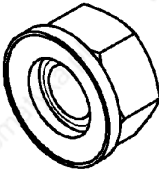
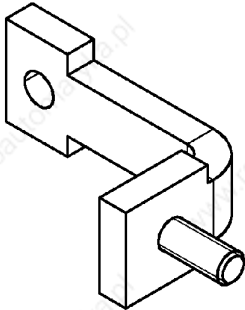
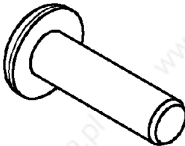
Datum	2006-02-13	Benennung	BEIPACKZETTEL HAS05.1-004-NNR-NN
Name	sonjrazz		
Material-Nr.	R911312185	Zeich-Nr.	109-1253-4275-00
Datei	DB196528	Ers.durch	..
		AEM-Nr.	..

Fig. 14-89: Accompanying note HAS05.1-004-NNR-NN



Accessories in the Drive System Rexroth IndraDrive

Accompanying note HAS05.1-004-NNL

<p>Made in Germany 109-1253-4836-00</p> <p style="text-align: right;"><b>Rexroth</b> <b>Bosch Group</b></p> <h2 style="text-align: center;">HAS05.1-004-NNL-NN</h2>  <p style="text-align: center;">R911312153</p> <table border="1" style="width: 100%; border-collapse: collapse; margin-top: 10px;"> <thead> <tr> <th style="width: 5%;">Stck</th> <th style="width: 75%;">Benennung</th> <th style="width: 20%;">MN</th> </tr> </thead> <tbody> <tr> <td>2</td> <td>SCHIENE-STROM HAS05.1-004-NNL</td> <td>R911315869</td> </tr> <tr> <td>2</td> <td>MUTTER-KOM-M 6,0-D12-H06,70 A2-B</td> <td>R911221473</td> </tr> <tr> <td>3</td> <td>KAB-BIND-D078-B4,8-C085-N220-TR-PA-*****</td> <td>R911269782</td> </tr> <tr> <td>1</td> <td>HALTERUNG KABEL HAS05.1-004-NNL/NNB</td> <td>R911315620</td> </tr> <tr> <td>1</td> <td>HALTERUNG HAS05.1-004 LINKS</td> <td>R911312216</td> </tr> <tr> <th>Stck</th> <th>Benennung</th> <th>MN</th> </tr> </tbody> </table>	Stck	Benennung	MN	2	SCHIENE-STROM HAS05.1-004-NNL	R911315869	2	MUTTER-KOM-M 6,0-D12-H06,70 A2-B	R911221473	3	KAB-BIND-D078-B4,8-C085-N220-TR-PA-*****	R911269782	1	HALTERUNG KABEL HAS05.1-004-NNL/NNB	R911315620	1	HALTERUNG HAS05.1-004 LINKS	R911312216	Stck	Benennung	MN	<table border="1" style="width: 100%; border-collapse: collapse;"> <thead> <tr> <th colspan="3">BEIPACKZETTEL HAS05.1-004-NNL-NN</th> </tr> <tr> <th style="width: 5%;">Stck</th> <th style="width: 75%;">Benennung</th> <th style="width: 20%;">MN</th> </tr> </thead> <tbody> <tr> <td>1</td> <td>HALTERUNG HAS05.1-004 LINKS</td> <td>R911312216</td> </tr> <tr> <td style="text-align: center; vertical-align: middle;">DB196346</td> <td style="text-align: center;"></td> <td style="text-align: right; vertical-align: middle;">1:2</td> </tr> <tr> <td>1</td> <td>HALTERUNG KABEL HAS05.1-004-NNL/NNB</td> <td>R911315620</td> </tr> <tr> <td style="text-align: center; vertical-align: middle;">DB194342</td> <td style="text-align: center;"></td> <td style="text-align: right; vertical-align: middle;">1:2</td> </tr> <tr> <td>3</td> <td>KAB-BIND-D078-B4,8-C085-N220-TR-PA-*****</td> <td>R911269782</td> </tr> <tr> <td style="text-align: center; vertical-align: middle;">DB196491</td> <td style="text-align: center;"></td> <td style="text-align: right; vertical-align: middle;">1:4</td> </tr> <tr> <td>2</td> <td>MUTTER-KOM-M 6,0-D12-H06,70 A2-B</td> <td>R911221473</td> </tr> <tr> <td style="text-align: center; vertical-align: middle;">DB-39762</td> <td style="text-align: center;"></td> <td style="text-align: right; vertical-align: middle;">2:1</td> </tr> <tr> <td>2</td> <td>SCHIENE-STROM HAS05.1-004-NNL</td> <td>R911315869</td> </tr> <tr> <td style="text-align: center; vertical-align: middle;">DB195396</td> <td style="text-align: center;"></td> <td style="text-align: right; vertical-align: middle;">1:1</td> </tr> <tr> <td colspan="3"> <table border="1" style="width: 100%; border-collapse: collapse;"> <tr> <td style="width: 20%;">Datum</td> <td style="width: 30%;">2006-02-10</td> <td style="width: 50%;">Benennung</td> </tr> <tr> <td>Name</td> <td>sonjrazz</td> <td>BEIPACKZETTEL HAS05.1-004-NNL-NN</td> </tr> <tr> <td>Material-Nr.</td> <td>R911312183</td> <td>Zeich-Nr. 109-1253-4274-00</td> </tr> <tr> <td>Datei</td> <td>DB196502</td> <td>Ers.durch .. AEM-Nr. ..</td> </tr> </table> </td> </tr> </tbody> </table>	BEIPACKZETTEL HAS05.1-004-NNL-NN			Stck	Benennung	MN	1	HALTERUNG HAS05.1-004 LINKS	R911312216	DB196346		1:2	1	HALTERUNG KABEL HAS05.1-004-NNL/NNB	R911315620	DB194342		1:2	3	KAB-BIND-D078-B4,8-C085-N220-TR-PA-*****	R911269782	DB196491		1:4	2	MUTTER-KOM-M 6,0-D12-H06,70 A2-B	R911221473	DB-39762		2:1	2	SCHIENE-STROM HAS05.1-004-NNL	R911315869	DB195396		1:1	<table border="1" style="width: 100%; border-collapse: collapse;"> <tr> <td style="width: 20%;">Datum</td> <td style="width: 30%;">2006-02-10</td> <td style="width: 50%;">Benennung</td> </tr> <tr> <td>Name</td> <td>sonjrazz</td> <td>BEIPACKZETTEL HAS05.1-004-NNL-NN</td> </tr> <tr> <td>Material-Nr.</td> <td>R911312183</td> <td>Zeich-Nr. 109-1253-4274-00</td> </tr> <tr> <td>Datei</td> <td>DB196502</td> <td>Ers.durch .. AEM-Nr. ..</td> </tr> </table>			Datum	2006-02-10	Benennung	Name	sonjrazz	BEIPACKZETTEL HAS05.1-004-NNL-NN	Material-Nr.	R911312183	Zeich-Nr. 109-1253-4274-00	Datei	DB196502	Ers.durch .. AEM-Nr. ..
Stck	Benennung	MN																																																																							
2	SCHIENE-STROM HAS05.1-004-NNL	R911315869																																																																							
2	MUTTER-KOM-M 6,0-D12-H06,70 A2-B	R911221473																																																																							
3	KAB-BIND-D078-B4,8-C085-N220-TR-PA-*****	R911269782																																																																							
1	HALTERUNG KABEL HAS05.1-004-NNL/NNB	R911315620																																																																							
1	HALTERUNG HAS05.1-004 LINKS	R911312216																																																																							
Stck	Benennung	MN																																																																							
BEIPACKZETTEL HAS05.1-004-NNL-NN																																																																									
Stck	Benennung	MN																																																																							
1	HALTERUNG HAS05.1-004 LINKS	R911312216																																																																							
DB196346		1:2																																																																							
1	HALTERUNG KABEL HAS05.1-004-NNL/NNB	R911315620																																																																							
DB194342		1:2																																																																							
3	KAB-BIND-D078-B4,8-C085-N220-TR-PA-*****	R911269782																																																																							
DB196491		1:4																																																																							
2	MUTTER-KOM-M 6,0-D12-H06,70 A2-B	R911221473																																																																							
DB-39762		2:1																																																																							
2	SCHIENE-STROM HAS05.1-004-NNL	R911315869																																																																							
DB195396		1:1																																																																							
<table border="1" style="width: 100%; border-collapse: collapse;"> <tr> <td style="width: 20%;">Datum</td> <td style="width: 30%;">2006-02-10</td> <td style="width: 50%;">Benennung</td> </tr> <tr> <td>Name</td> <td>sonjrazz</td> <td>BEIPACKZETTEL HAS05.1-004-NNL-NN</td> </tr> <tr> <td>Material-Nr.</td> <td>R911312183</td> <td>Zeich-Nr. 109-1253-4274-00</td> </tr> <tr> <td>Datei</td> <td>DB196502</td> <td>Ers.durch .. AEM-Nr. ..</td> </tr> </table>			Datum	2006-02-10	Benennung	Name	sonjrazz	BEIPACKZETTEL HAS05.1-004-NNL-NN	Material-Nr.	R911312183	Zeich-Nr. 109-1253-4274-00	Datei	DB196502	Ers.durch .. AEM-Nr. ..																																																											
Datum	2006-02-10	Benennung																																																																							
Name	sonjrazz	BEIPACKZETTEL HAS05.1-004-NNL-NN																																																																							
Material-Nr.	R911312183	Zeich-Nr. 109-1253-4274-00																																																																							
Datei	DB196502	Ers.durch .. AEM-Nr. ..																																																																							

Fig. 14-90: Accompanying note HAS05.1-004-NNL-NN



Accessories in the Drive System Rexroth IndraDrive

Technical Data

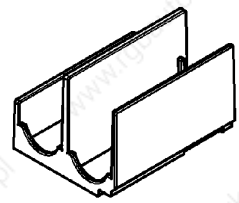
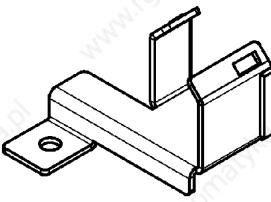
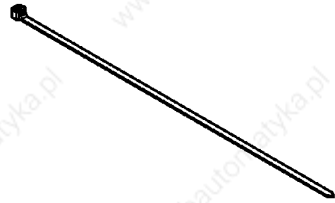
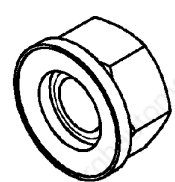
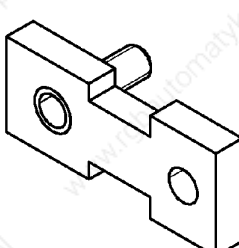
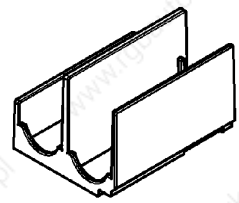
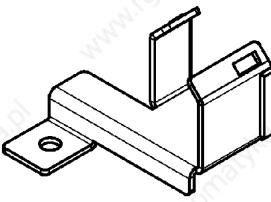
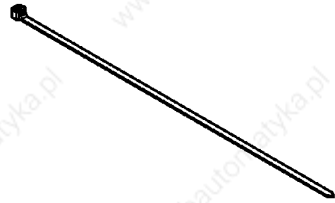
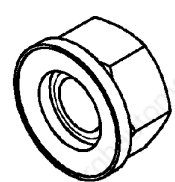
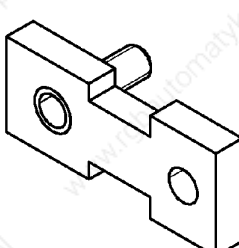
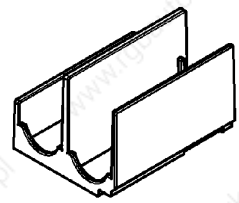
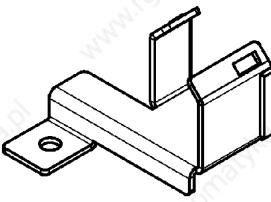
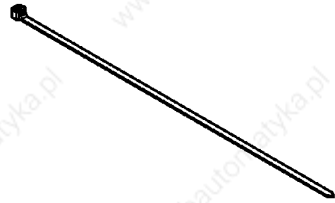
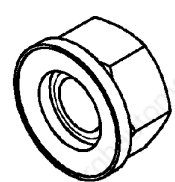
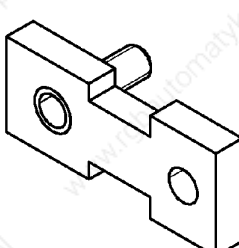
Connection, Mounting Dimensions

Allowed Cross Sections, Lengths

The accessory HAS05.1-004 is used to connect lines with ring cable lugs. At each connection point, it is allowed to use 1 or 2 lines of the same cross section.

	Unit	HAS05.1-004-NNL	HAS05.1-004-NNR
allowed connection cross section stranded wire; 1 ring cable lug mounted	mm <sup>2</sup>	35 50	35 50
	AWG	2 1/0	2 1/0
allowed connection cross section stranded wire; 2 ring cable lugs mounted	mm <sup>2</sup>	35 50	35 50
	AWG	2 1/0	2 1/0
maximum tightening torque	Nm	6,6	6,6
minimum tightening torque	Nm	5,4	5,4
allowed length, required lengths of lay etc.		see <a href="#">chapter 13.1.6 Connection of the DC Bus Connections on page 187</a>	
fusing		Observe requirement on line protection! see <a href="#">chapter 13.1.6 Connection of the DC Bus Connections on page 187</a>	

Fig.14-91: Connection cross section HAS05.1-004

Mounting Dimensions

When mounted, the accessory requires the following mounting clearance to the left or to the right.

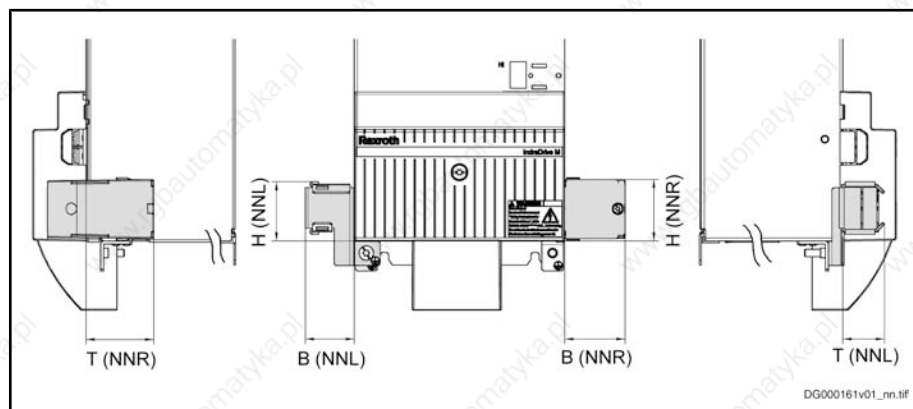

Fig.14-92: Mounting dimensions HAS05.1-004-NNR, -NNL



Observe the minimum bending radiuses of the lines used. This requires additional mounting clearance, particularly on the left side.

## Accessories in the Drive System Rexroth IndraDrive

Dimension	Unit	HAS05.1-004-NNL	HAS05.1-004-NNR
mounting dimension B	mm	41	50
mounting dimension H	mm	50	51
mounting dimension T	mm	35	56

Fig. 14-93: Mounting dimensions HAS05.1-004

**How to Mount HAS05.1-004****Cases to be Distinguished**

- outgoing direction of the lines to the right (HAS05.1-004-NNR)
- outgoing direction of the lines to the left (HAS05.1-004-NNL)
- outgoing direction of the lines to both sides (HAS05.1-004-NNR and HAS05.1-004-NNL)

**Outgoing Direction of the Lines to the Right (HAS05.1-004-NNR)**

## 1. Mount bar:

**Without** DC bus contact bars (see [picture 1](#)):

screw bar (5) and end piece (12) to terminal block (tightening torque: 6 Nm)

**With** DC bus contact bars (see [picture 2](#)):

screw bar (5), DC bus contact bar (11) and connection piece (13) to terminal block (tightening torque: 6 Nm)

## 2. Mount line:

(see [picture 1](#) and [picture 2](#))

screw ring cable lug (10) to bar (5) (tightening torque: 6 Nm; with 2 ring cable lugs, observe inverse arrangement)

## 3. Mount touch guard:

(see [picture 3](#))

mount touch guard of drive controller (tightening torque: max. 2.8 Nm)

insert touch guard of bars (2) and touch guard cover (1) and screw them together (tightening torque: 1.6 Nm)

Accessories in the Drive System Rexroth IndraDrive

Picture 1

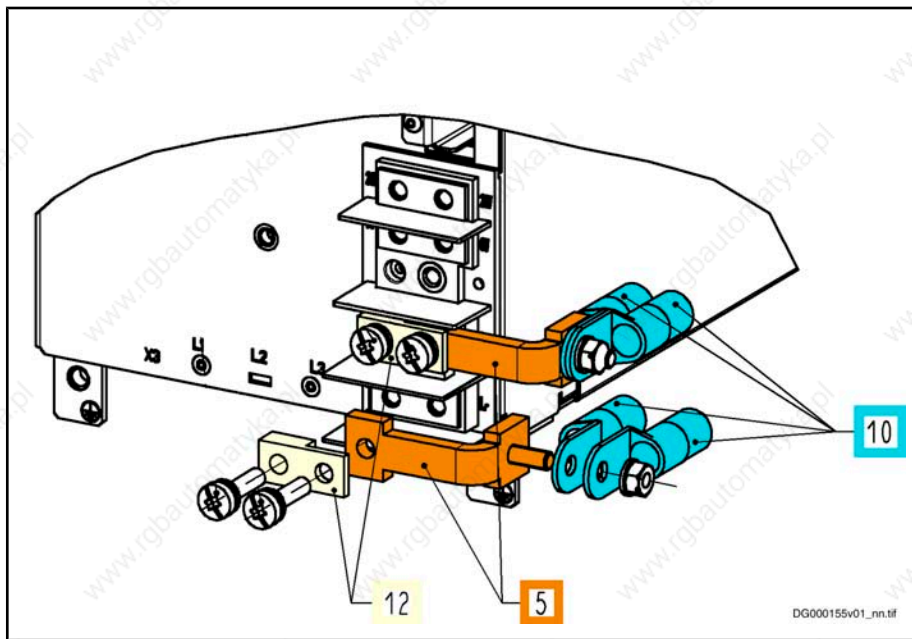

Fig. 14-94: HAS05.1-004-NNR; outgoing direction of the lines to the right; without DC bus contact bars

Picture 2

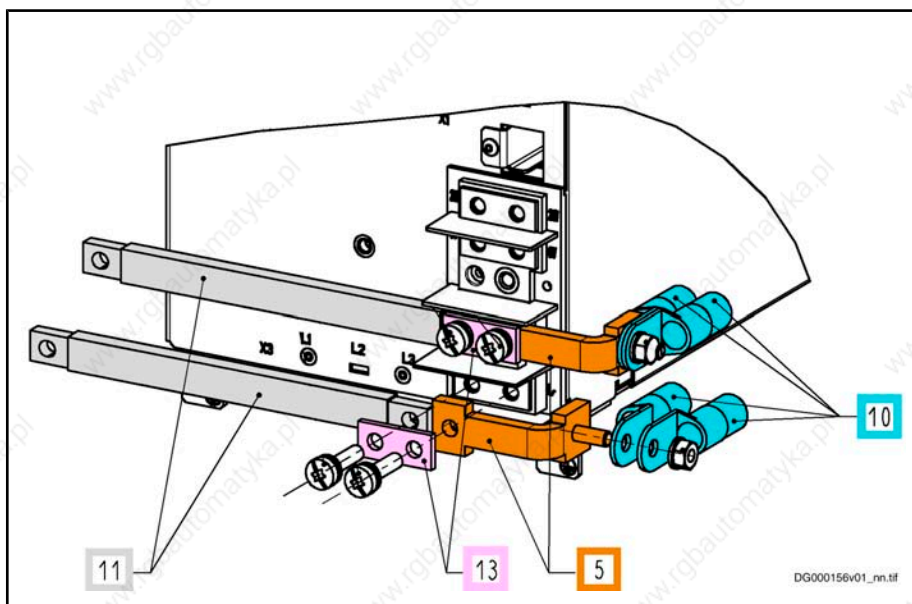

Fig. 14-95: HAS05.1-004-NNR; outgoing direction of the lines to the right; with DC bus contact bars

## Accessories in the Drive System Rexroth IndraDrive

Picture 3

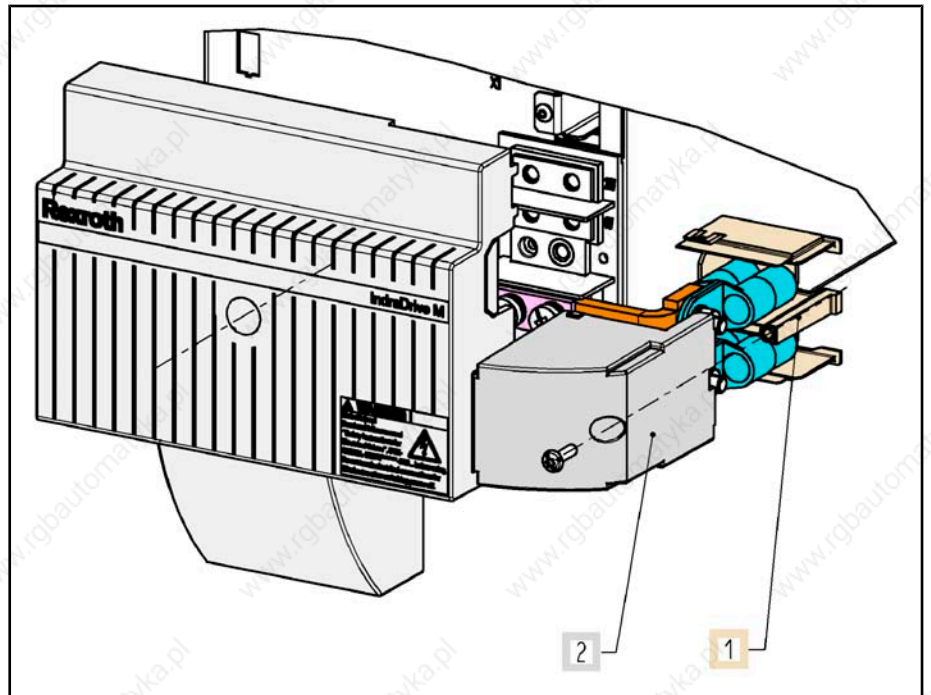

Fig. 14-96: HAS05.1-004-NNR; mounting the touch guard



Make sure there is strain relief for the lines outgoing backward.

#### Outgoing Direction of the Lines to the Left (HAS05.1-004-NNL)

1. Mount bar:
  - Without** DC bus contact bars (see [picture 4](#)):  
screw bar (05) and end piece (12) to terminal block (tightening torque: 6 Nm)
  - With** DC bus contact bars (see [picture 5](#)):  
screw bar (05), DC bus contact bar (11) and connection piece (13) to terminal block (tightening torque: 6 Nm)
2. Put fixing device (01) on bar (05)
3. Screw cable holder (02) to left equipment grounding connection
4. Mount line:
  - (see [picture 4](#) and [picture 5](#))
  - screw ring cable lug (10) to bar (05) (tightening torque: 6 Nm; with 2 ring cable lugs, observe inverse arrangement)
  - fix lines with cable tie to cable holder (02)
5. Mount touch guard of drive controller (tightening torque: max. 2.8 Nm)



Accessories in the Drive System Rexroth IndraDrive

Picture 4

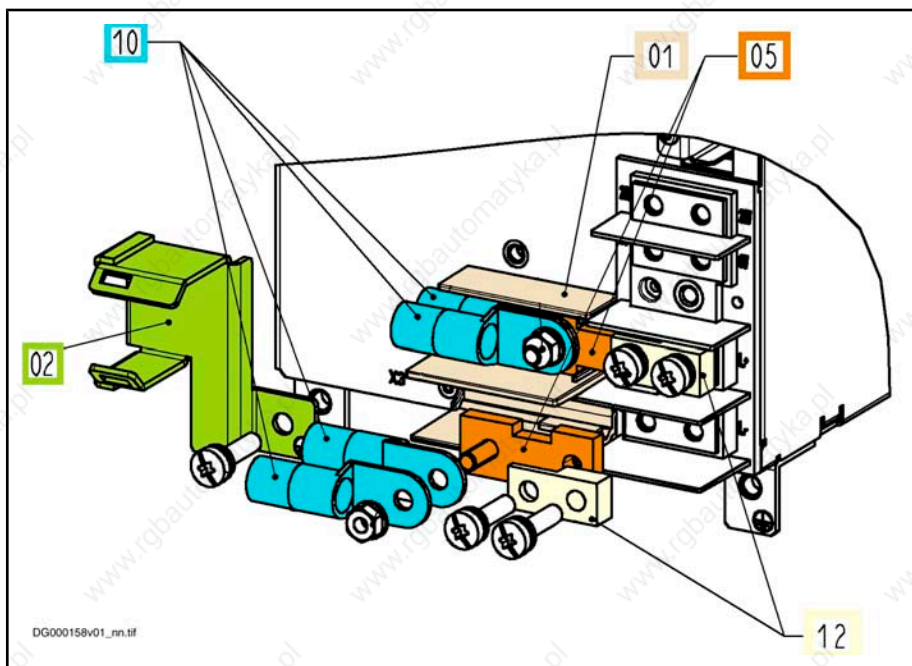

Fig. 14-97: HAS05.1-004-NNL; outgoing direction of the lines to the left; without DC bus contact bars

Picture 5

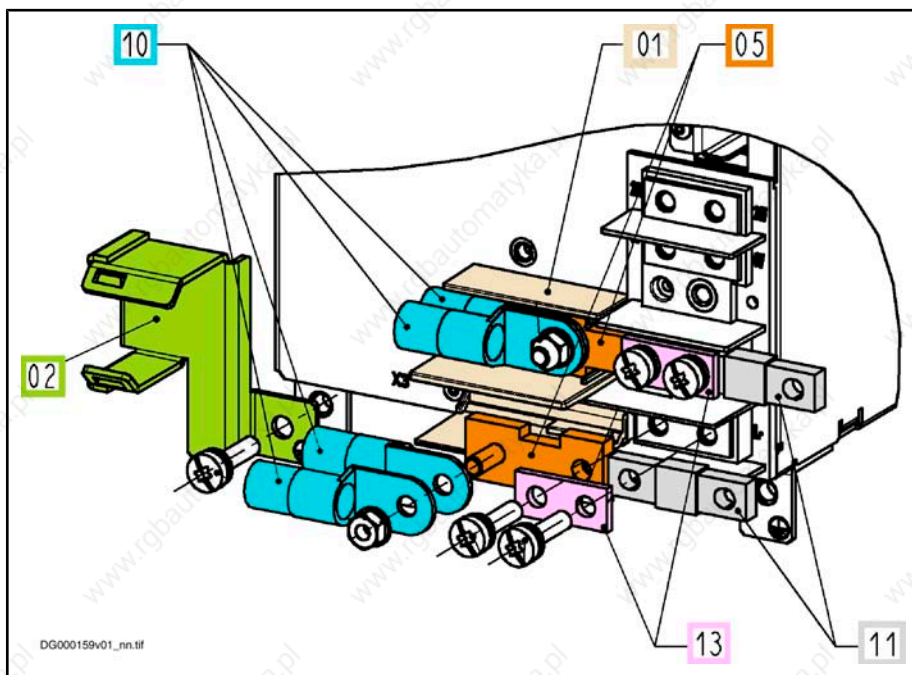

Fig. 14-98: HAS05.1-004-NNL; outgoing direction of the lines to the left; with DC bus contact bars

Accessories in the Drive System Rexroth IndraDrive



Beneath the touch guard, run the non-twisted lines in parallel.  
Outside of the touch guard (after the strain relief), twist the line pairs.  
In the case of four lines at the connections L+ and L-, twist L+ and L- to form one pair.  
Keep the surface between the individual lines of a pair as small as possible.  
Run the line pairs with the smallest possible distance to each other.

**Outgoing Direction of the Lines to Both Sides (HAS05.1-004-NNR and HAS05.1-004-NNL)**

For mounting with outgoing direction to both sides, observe the descriptions on "Outgoing Direction of the Lines to the Left (HAS05.1-004-NNL)" and "Outgoing Direction of the Lines to the Right (HAS05.1-004-NNR)".

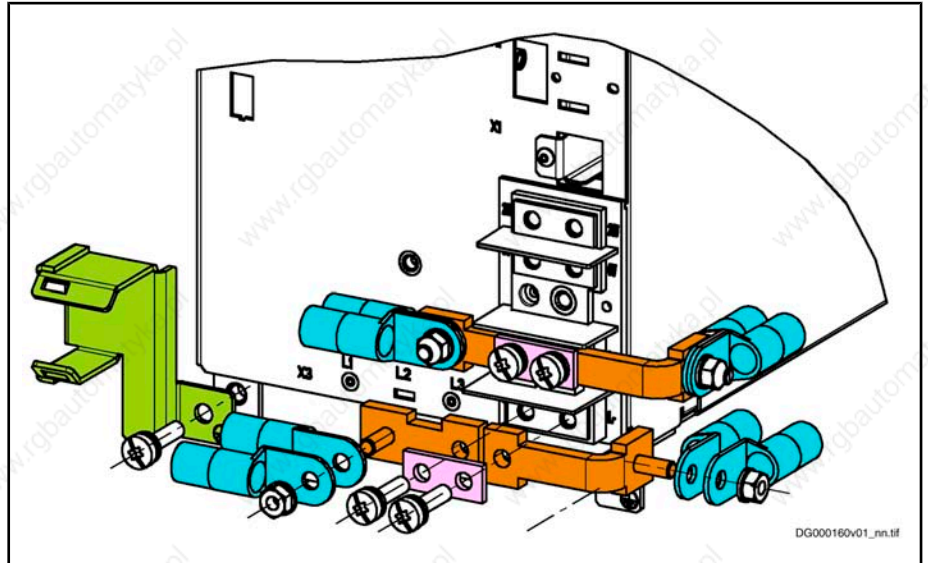

Fig. 14-99: Mounting HAS05.1-004-NNL and -NNR

**14.5.7 HAS05.1-005, Signal Level Converter RS232/RS485 (Preliminary Usage)**

Accessory	Usage
HAS05.1-005-NNN-NN	converts serial interface of Rexroth Indra-Drive control sections from RS232 standard to RS485 standard

Fig. 14-100: Usage

**Scope of Supply**

**Scope of Supply**

Order this accessory as a separate item. It is not part of the scope of supply of the device.

Parts of the accessory: see accompanying note

*Scope of supply*

- converter
- connector at X2 and X3
- cable tie
- accompanying note

Accessories in the Drive System Rexroth IndraDrive

Technical Data

Dimensions

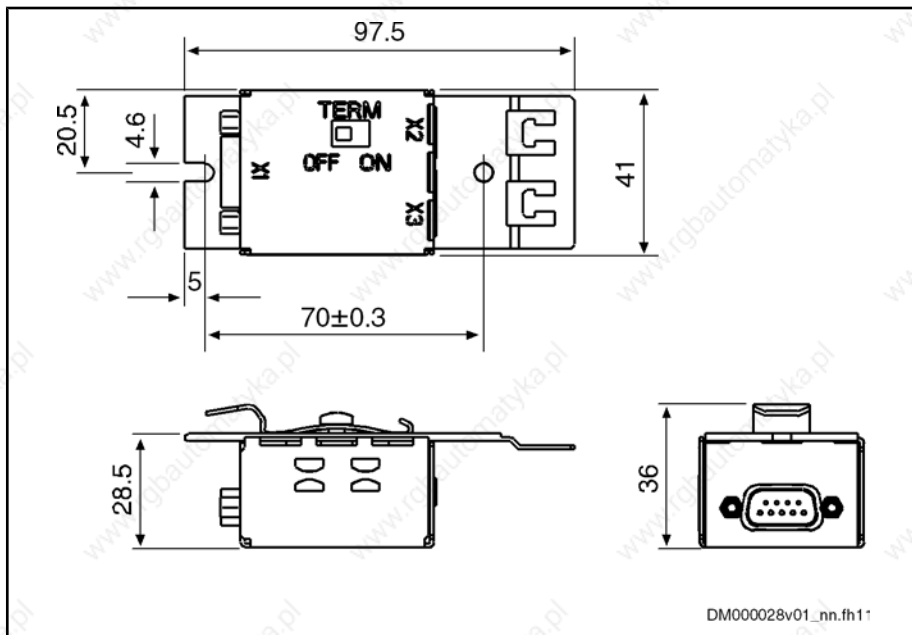

Fig. 14-101: Dimensions



HAS05.1-005 can be mounted on a top-hat rail. For mounting it at a wall, remove the top-hat rail clip at the back of the housing.

You can also mount HAS05.1-005 on electrically insulating surfaces.

Electrical Data

Characteristic	Unit	Min.	Typ.	Max.
number of nodes				31
allowed cable length <sup>1)</sup>	m			500
transmission rates <sup>2)</sup>	kBaud	9,6		115
mode of operation		semi-duplex 2-wire line		
connection between X1 and X2, X3		galvanically connected		
allowed voltage difference between the reference potentials of the drive controllers (housing)	V			20
current consumption at X1.1	mA			50
termination (TERM)		switchable ON, OFF		
short-circuit protection		Data+ against Data- Data+, Data- against GND		
cable length at X1	m			5
cable length at X2, X3	m	comply with bus length, see allowed cable length		



Accessories in the Drive System Rexroth IndraDrive

Characteristic	Unit	Min.	Typ.	Max.
connections X2, X3		spring terminal		
connection cross section stranded wire	mm <sup>2</sup> / AWG	0.14–1.5 / 28–16; ferrule without insulating sleeve		

- 1) bus length RS485, corresponds to total length of all connected cables
- 2) is set via firmware used

Fig. 14-102: Technical characteristics

Position of Connections, Termination



Fig. 14-103: HAS05.1-005 with connection cables

Pin Assignment X1

Connection	Signal	Function
1	V <sub>cc</sub>	supply voltage (+5V)
2	RxD	reception line (Receive Data)
3	TxD	transmission line (Transmit Data)
4	n. c.	n. c.
5	GND	reference potential
6	n. c.	n. c.
7	n. c.	n. c.
8	RTS	Request to send
9	n. c.	n. c.

Fig. 14-104: Pin assignment X1

## Accessories in the Drive System Rexroth IndraDrive

## Pin Assignment X2

Connection	Signal	Function
1	Data+	data transmission +
2	Data-	data transmission -
3	Shield	connection overall shield

Fig. 14-105: Pin assignment X2

## Pin Assignment X3

Connection	Signal	Function
1	Data+	data transmission +
2	Data-	data transmission -
3	Shield	connection overall shield
4	GND	connection internal shield (signal shield)

Fig. 14-106: Pin assignment X3

## Installation

## General Information

Three connections connect the accessory HAS05.1-005 to form an RS485 bus:

- connection X1 to serial interface X2 at control section
- connection X2 to connection X3 at next HAS05
- connection X2 to bus master (e.g. RS232/485 converter controlled by a PC)



Terminate the RS485 bus line at the most remote bus ends.

To do this, switch on the termination at the bus master (converter at PC). At the last node, set the "TERM" switch to "ON".



See also Functional Description of firmware "Communication via RS485 Interface" and Parameter Description, e.g. "P-0-4050, Answer delay RS-232/485"

Accessories in the Drive System Rexroth IndraDrive

Example of Connection

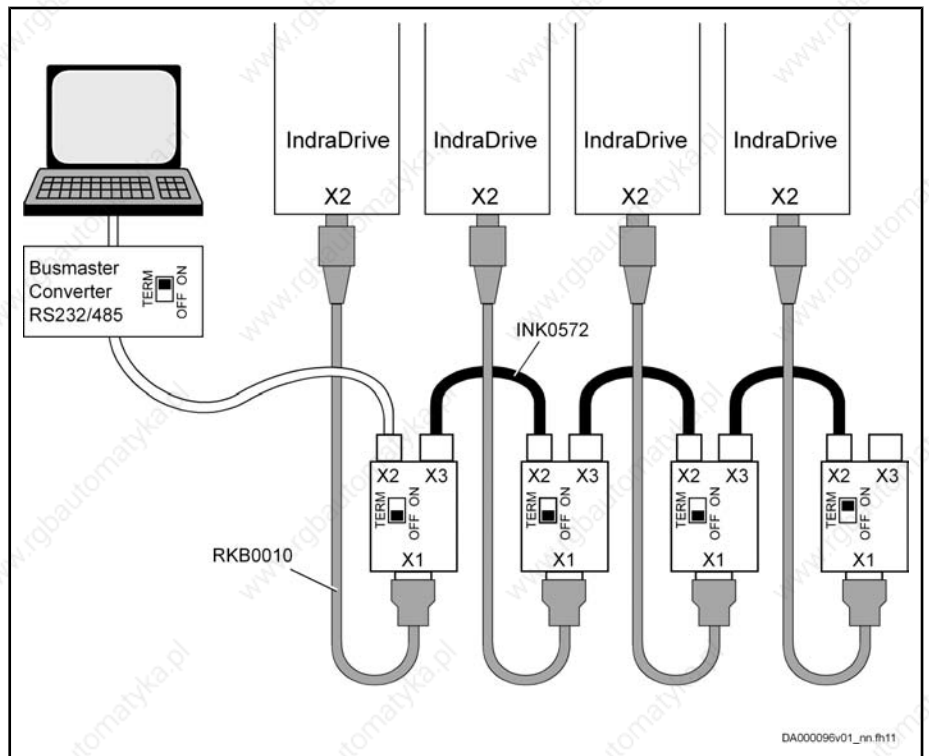

Fig. 14-107: Example of connection



Connect PC and RS485 bus to a so-called bus master converter; this RS232/485 converter automatically generates the RTS control signal.

The accessory HAS05.1-005 does not accomplish this function!

Connection at X1

Connection From X1 to Control Section (X2)

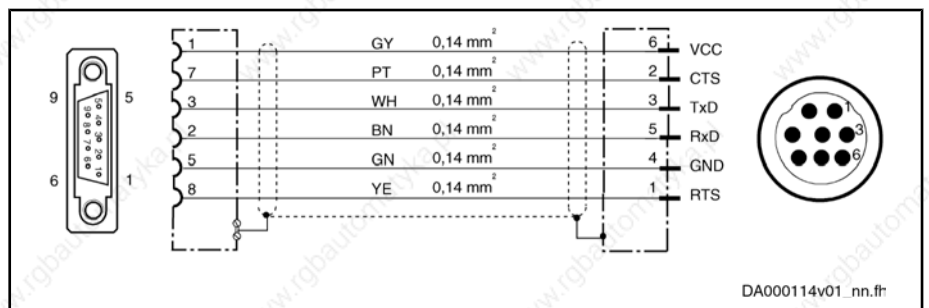

Fig. 14-108: Connection cable RKB0010



For **direct** connection from X1 to the control section, use our cable **RKB0010** and observe its maximum allowed length (see "Electrical Data" on page 286).

Connection at X2 and X3

Connect X2 and X3 with a cable according to the interconnection diagram below.

Accessories in the Drive System Rexroth IndraDrive

Connection between X2 and X3

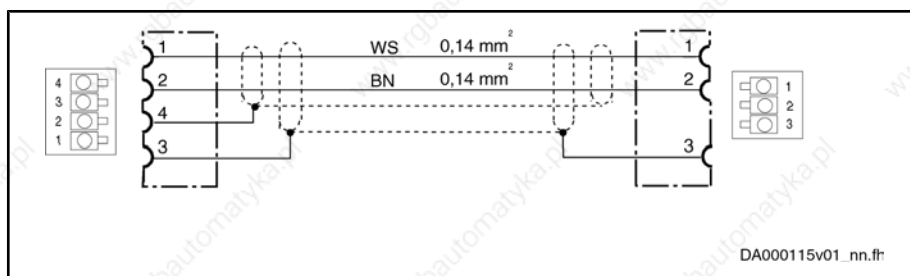

Fig. 14-109: Connection cable at X2 and X3



To assemble connection cables at X2 and X3, use our non-assembled cable **INK0572**.

Strain Relief at Connection X2 and X3



Fig. 14-110: Strain relief at connection X2 and X3



Provide sufficient strain relief for the connections at X2 and X3! Use the supplied cable ties.

## 14.5.8 HAS05.1-006, Adapter for Controlling Motor Holding Brake (Preliminary)

### Usage

<b>Assignment</b>	The accessory HAS05.1-006 can be used at the following drive controllers: <ul style="list-style-type: none"> <li>• HMS02.1N-W0028</li> <li>• HMS02.1N-W0054</li> </ul>
<b>Function</b>	The accessory HAS05.1-006 switches the voltage supply of the motor holding brake (connection point X6, motor temperature monitoring and motor holding brake) and has a feedback contact to the switching action.
<b>Scope of Supply</b>	Connector at X44 (Connector at X6 is not part of the scope of supply. Use the connector of the power section.)
<b>Identification, Parts</b>	The accessory has a type plate for identification.

Accessories in the Drive System Rexroth IndraDrive

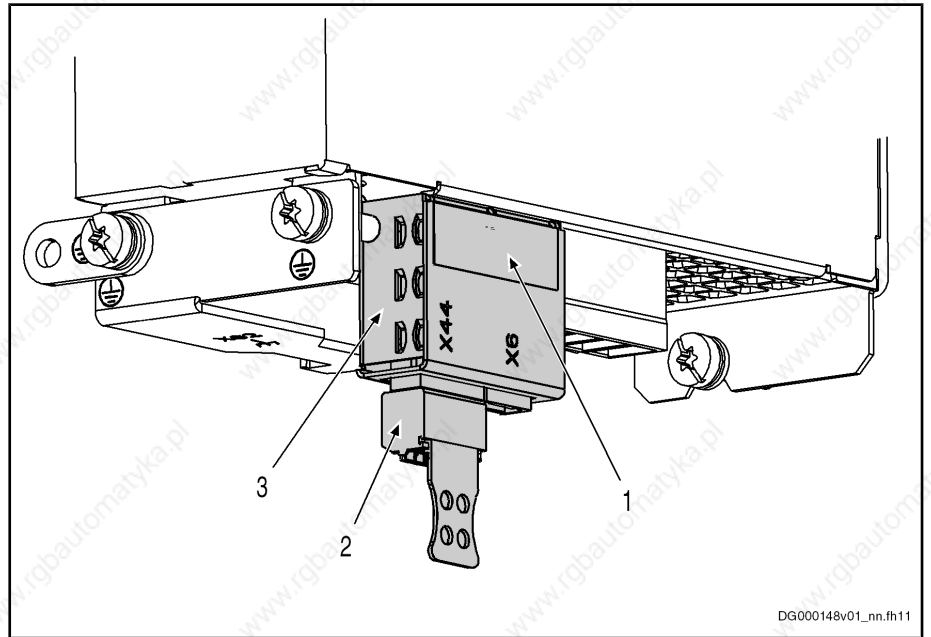

DG000148v01\_nn.fh11

- 1 type plate
- 2 connector at connection point X44
- 3 HAS05.1-006

Fig. 14-111: HAS05.1-006 at connection point X6 at drive controller

Technical Data

Mounting Dimensions

The accessory requires the following mounting clearance at the drive controller.

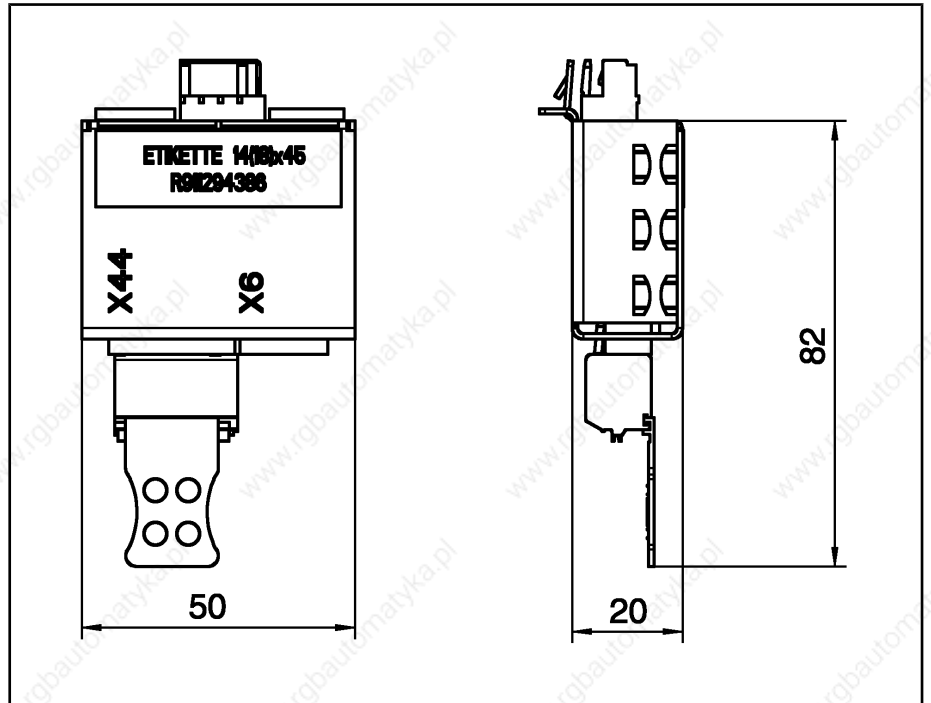

data in mm

Fig. 14-112: Mounting dimensions

Accessories in the Drive System Rexroth IndraDrive



Observe the minimum bending radiuses of the lines used. This requires additional mounting clearance at the drive controller, particularly downward.

**Connection Points**

**X6**



The connection point is described in the Project Planning Manual "Rexroth IndraDrive Supply Units and Power Sections" → "Functions and Electrical Connection Points" → "X6, Motor Temperature Monitoring and Motor Holding Brake".

**X44**

View	Connection	Signal name	Function
 DG000147v01_nn.FH1*	X44.1	+24V	relay control
	X44.2		
	X44.3	0V	
	X44.4		
	X44.5	nc_Rel	relay contact "N/C"
	X44.6	nc_Rel	

Spring terminal (connector)	Unit	Min.	Max.
connection cross section solid wire	mm <sup>2</sup>	0,14	1,5
connection cross section stranded wire	mm <sup>2</sup>	0,14	1,5
connection cross section	AWG	28	16
<b>Electrical data</b>			
supply d1 (X44.1/2, X44.3/4)	V	19,2	28,8
	mA		50
switching capacity K1 (X44.5, X44.6)	A	-	2
switching capacity K2 (X6.3, X6.4)	V		28,8
minimum load of the contacts	mA	10	
contact resistance at minimum current	Ω		1
pick up delay	ms		30
drop out delay	ms		30
time constant of load	ms	ohmic	
number of switching actions at maximum time constant of load		1 × 10 <sup>6</sup>	
number of mechanical switching cycles		1 × 10 <sup>6</sup>	

Accessories in the Drive System Rexroth IndraDrive

short circuit protection		see description of connection point "X6, Motor Temperature Monitoring and Motor Holding Brake" in the Project Planning Manual "Rexroth IndraDrive Supply Units and Power Sections"
overload protection		

Fig. 14-113: Function, pin assignment

Usage

Block Diagram

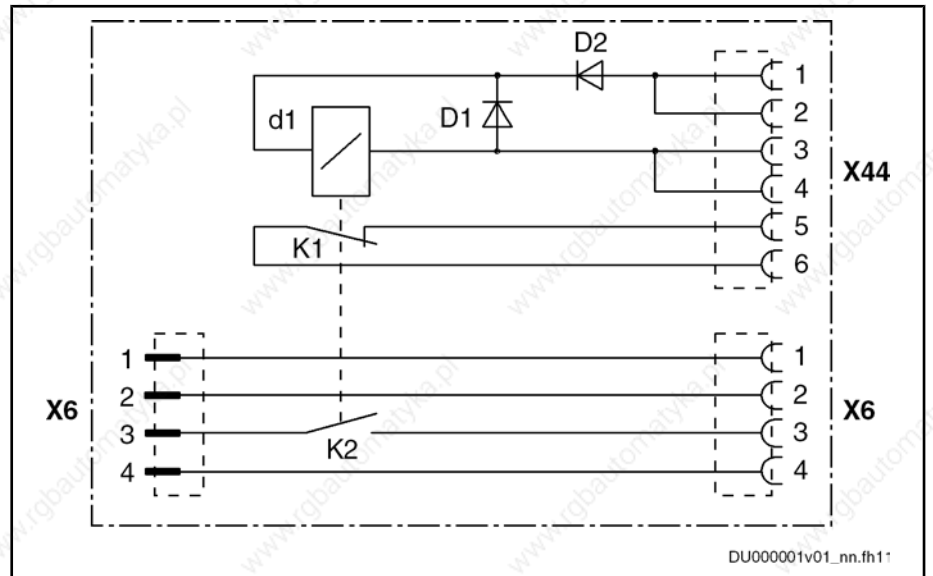

- D1 free-wheeling diode
- D2 polarity reversal protection diode
- d1 relay
- K1 N/C contact
- K2 N/O contact

Fig. 14-114: Block diagram



Accessories in the Drive System Rexroth IndraDrive

Example of Use

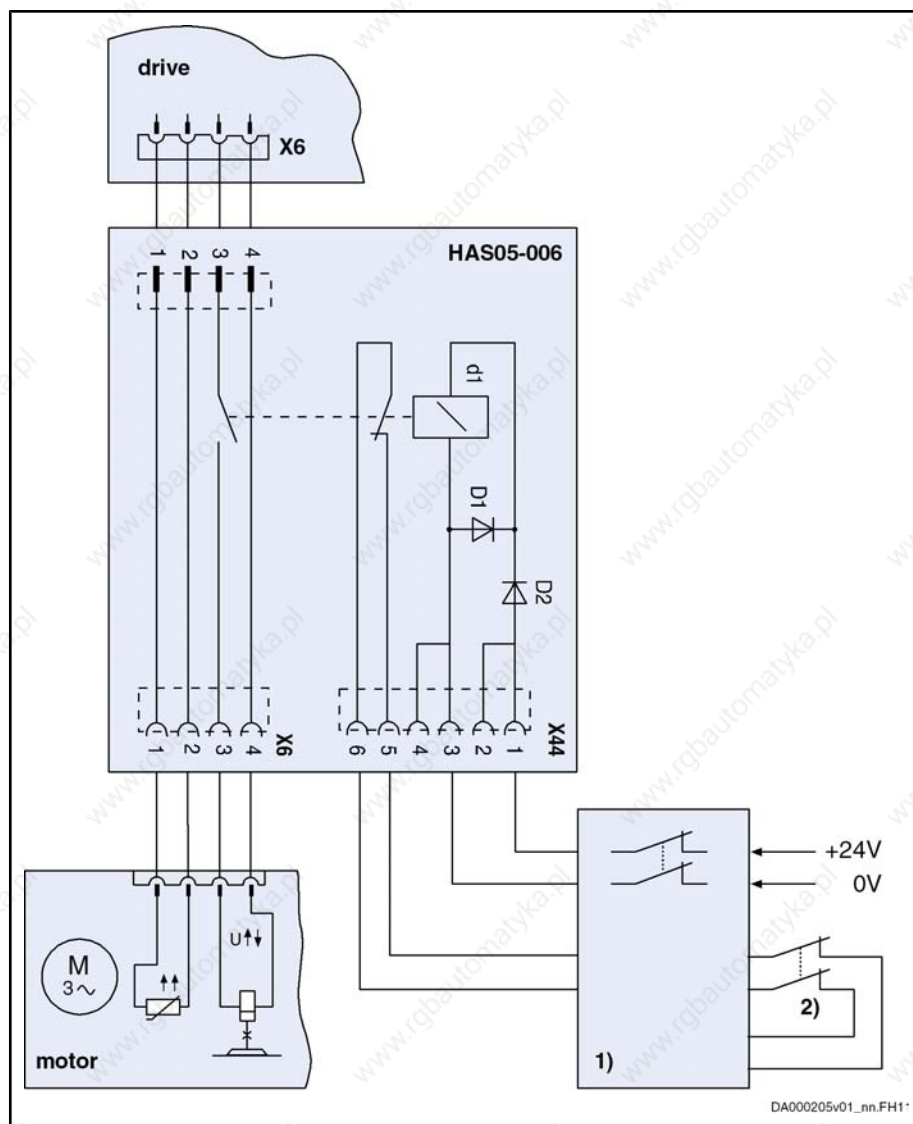

1) safety door monitor  
 2) safety door contacts  
 Fig.14-115: Example of connection

Mounting

Mount HAS05.1-006

1. Plug HAS05.1-006 in connection point X6 at drive controller

Make sure that HAS05.1-006 snaps into at X6 at the drive controller.

2. Plug connectors X6 and X44 in HAS05.1-006

Make sure there is sufficient strain relief for the connectors.

Dismount HAS05.1-006

1. Remove connection cable from HAS05.1-006

2. Loosen snap-in connection with screwdriver and remove HAS05.1-006 from drive controller

### 14.5.9 HAS05.1-007, Adapter From D-Sub to Terminal Connector (Preliminary)

#### Usage

The adapter **HAS05.1-007** exists in the following types of design:

- **NNL**: mounting direction left (outgoing direction spring terminal left)
- **NNR**: mounting direction right (outgoing direction spring terminal right)

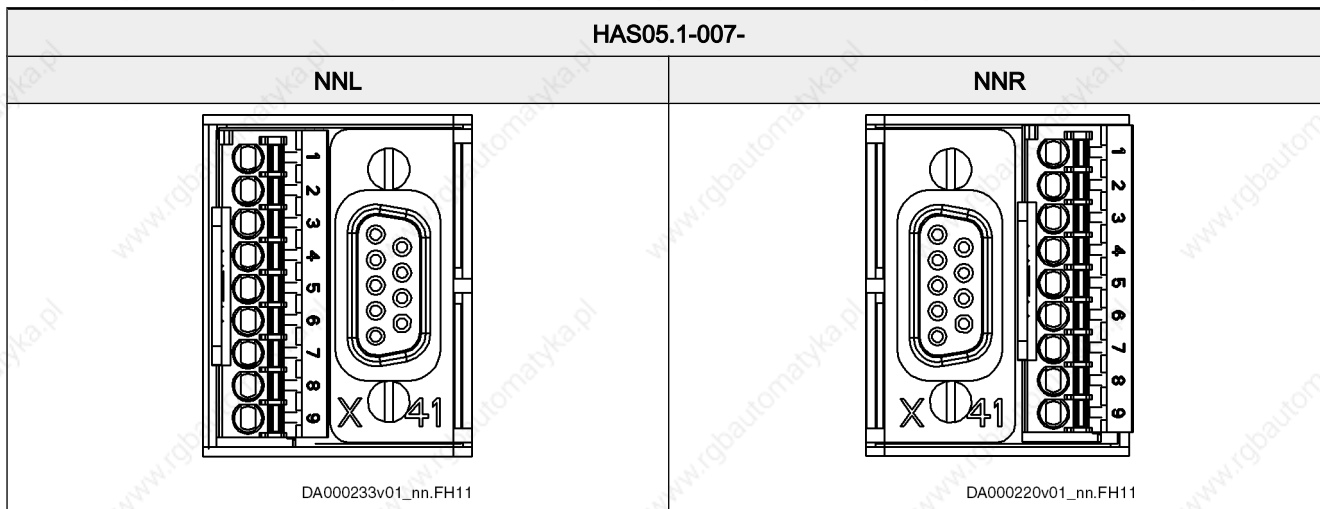

Fig. 14-116: Types of design

**Assignment** The accessory HAS05.1-007 can be used at the following control sections:

HAS05.1-007-NNL	HAS05.1-007-NNR
CSH01.1C at X41 (condition: option 3 not equipped)	CSH01.1C at X41
CDB01.1C at X41.1 (option ST1)	CSH01.2C at X41
	CDB01.1C at X41.2 (option ST2)

Fig. 14-117: Assignment HAS05.1-007

At **CDB01** control sections, you can use both types of design together. However, there is the following restriction:

When using the type of design **NNL** at **HMD01.1N-W0012** or **HMD01.1N-W0020** drive controllers of a width of 50 mm, you cannot use the adapter of type of design **NNR** to the left of the neighboring control section.

Accessories in the Drive System Rexroth IndraDrive

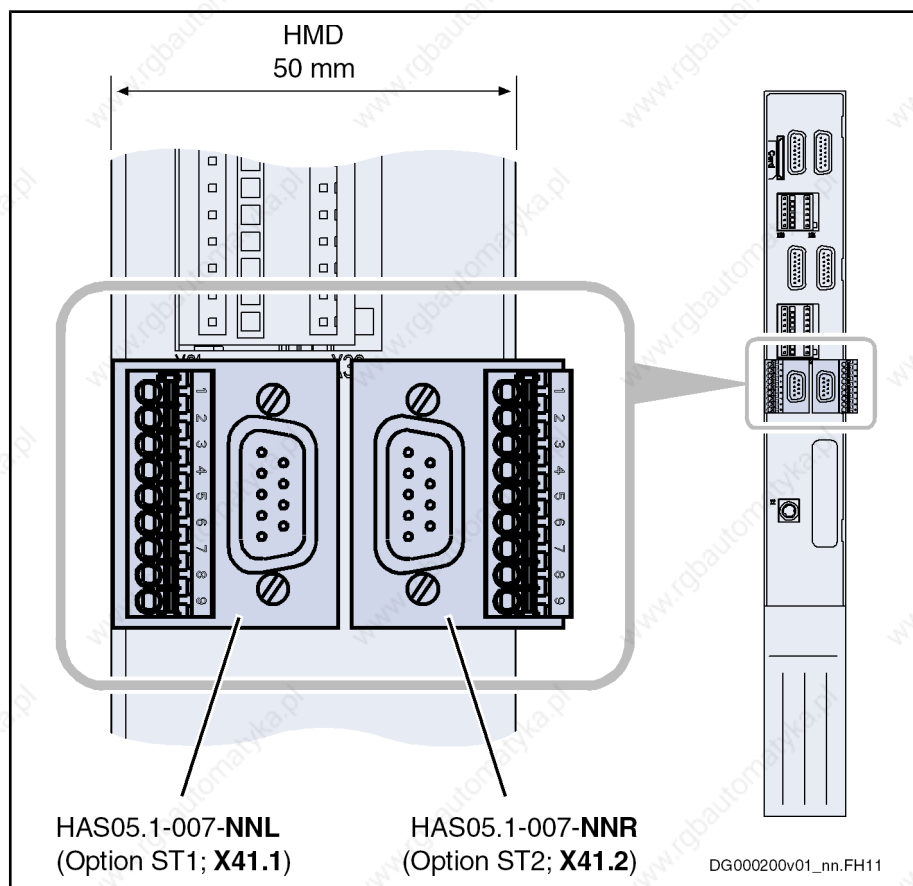

Fig.14-118: HAS05.1-007-NNL and -NNR at HMD drive controller of a width of 50 mm

**Function** Universal adapter for safety technology

Usage:

1. Converter of D-Sub connection to terminal connection for an axis
2. Connection of additional component HAT01 to control section and optional module S1
3. Converter of D-Sub connection to terminal connection for bus connection of optional modules S1 of the axes of one zone (see figure "Wiring Example With HAS05.1-007-NNR" on page 300)

**Identification, Parts** The accessory has a type plate for identification.

## Accessories in the Drive System Rexroth IndraDrive

## HAS05.1-007-NNL

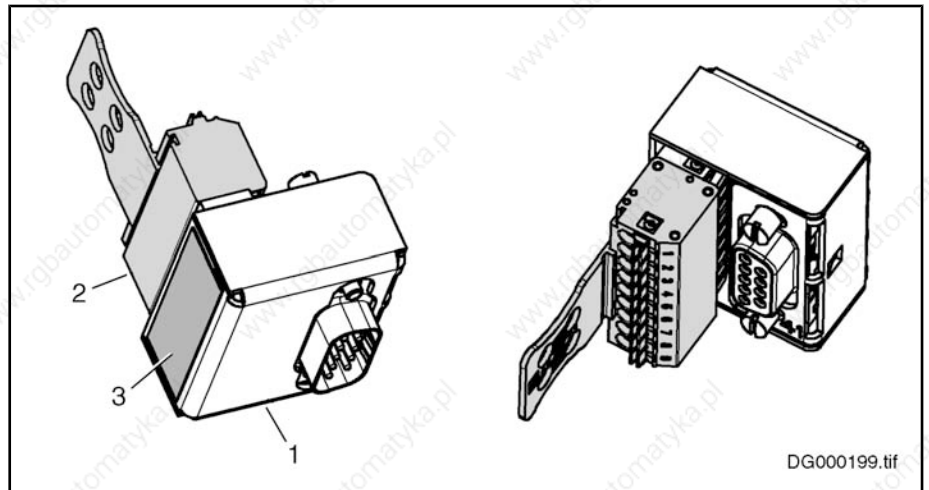

- 1 adapter  
2 connector (spring terminal)  
3 type plate

Fig. 14-119: HAS05.1-007-NNL

## HAS05.1-007-NNR

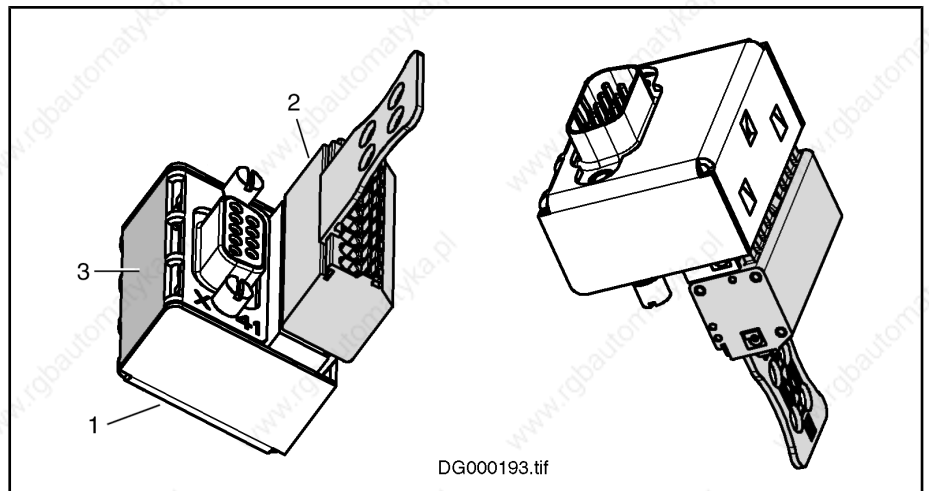

- 1 adapter  
2 connector (spring terminal)  
3 type plate

Fig. 14-120: HAS05.1-007-NNR

The adapter is plugged in the connection point X41 (resp. X41.1 or X41.2 for double-axis devices) of the control section and secured with screws.

## Technical Data

## Mounting Dimensions

The accessory requires the following mounting clearance at the drive controller.

Accessories in the Drive System Rexroth IndraDrive

HAS05.1-007-NNL

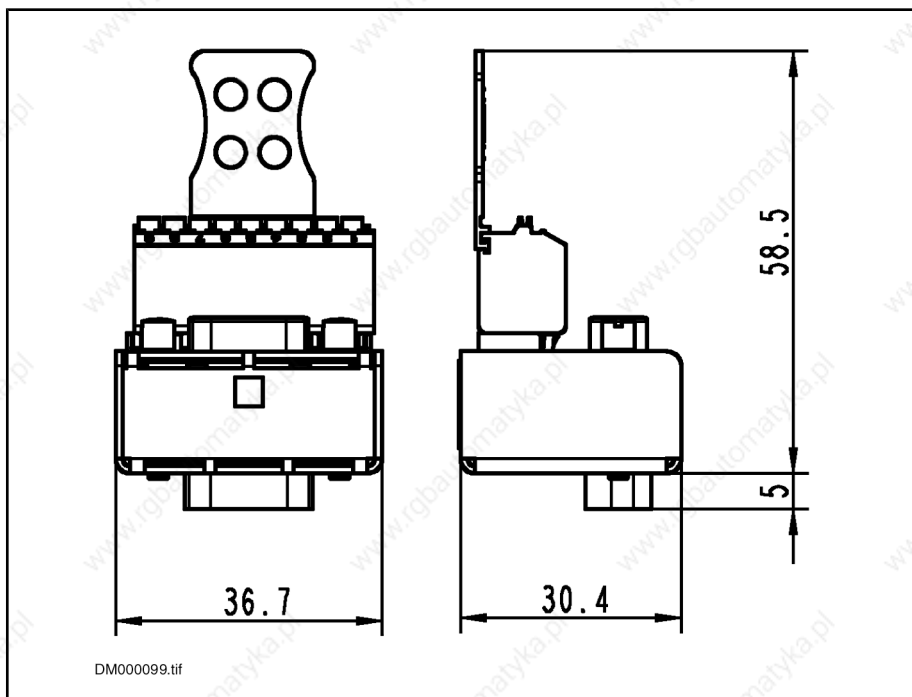

data in mm

Fig. 14-121: Mounting dimensions HAS05.1-007-NNL

HAS05.1-007-NNR

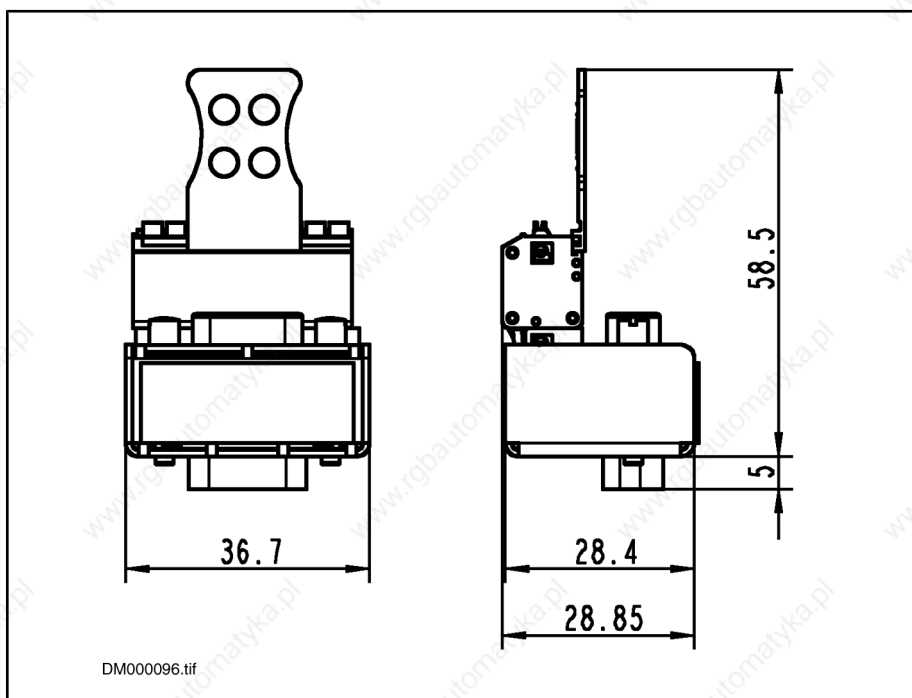

data in mm

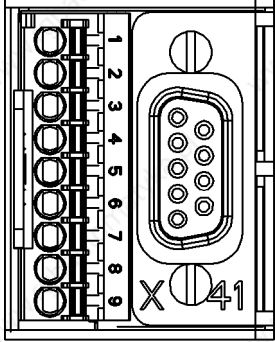

Fig. 14-122: Mounting dimensions HAS05.1-007-NNR



Observe the minimum bending radiuses of the lines used. This requires additional mounting clearance at the front of the drive controller.

Accessories in the Drive System Rexroth IndraDrive

Connection Point X41

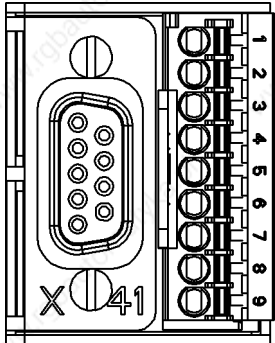
View	Connection (terminal)	Signal name	Function
<p>HAS05.1-007-NNL spring terminal / D-Sub female connector</p>  <p>DA000233v01_nn.FH11</p>	1	X41.1	<p>The adapter brings the connections of the optional modules L1 or S1 to the connections 1–9 of a spring terminal and a D-Sub female connector.</p>  <p>Description of connection point X41: see Project Planning Manual "Rexroth IndraDrive Control Sections", section "Optional Modules for Control Sections, Safety Technology".</p>
	2	X41.2	
	3	X41.3	
	4	X41.4	
	5	X41.5	
	6	X41.6	
	7	X41.7	
	8	X41.8	
	9	X41.9	
<p>HAS05.1-007-NNR D-Sub female connector / spring terminal</p>  <p>DA000220v01_nn.FH11</p>			
<b>Spring terminal (connector)</b>	<b>Unit</b>	<b>Min.</b>	<b>Max.</b>
cable cross section stranded wire	mm <sup>2</sup>	0,5	1,5
cable cross section	AWG	20	16
coding	At both types of design, the connection point 5 has been coded, i.e. provided with a coding section. The spring terminal was already assembled accordingly at the factory.		



Accessories in the Drive System Rexroth IndraDrive

<p><b>Electrical data</b></p>	<p>Description of connection point X41: see Project Planning Manual "Rexroth IndraDrive Control Sections", section "Optional Modules for Control Sections, Safety Technology".</p>
<ul style="list-style-type: none"> <li>• <b>mating connector for D-Sub female connector</b></li> <li>• <b>ribbon cable</b></li> </ul>	<ul style="list-style-type: none"> <li>• <b>RBS0017/S05</b> → D-Sub connector, 9-pin</li> <li>• <b>REB0401</b> → ribbon cable, 9-pin, can be ordered in steps of 0.5 m</li> </ul> <p>For professional assembly of the ribbon cable in the D-Sub connector, use the following Tyco tools:</p> <ul style="list-style-type: none"> <li>• Pistol-Grip tool (part number 734155-1)</li> <li>• matrix for D-Sub connector (part number 734148-1)</li> </ul>

Fig.14-123: Function, pin assignment

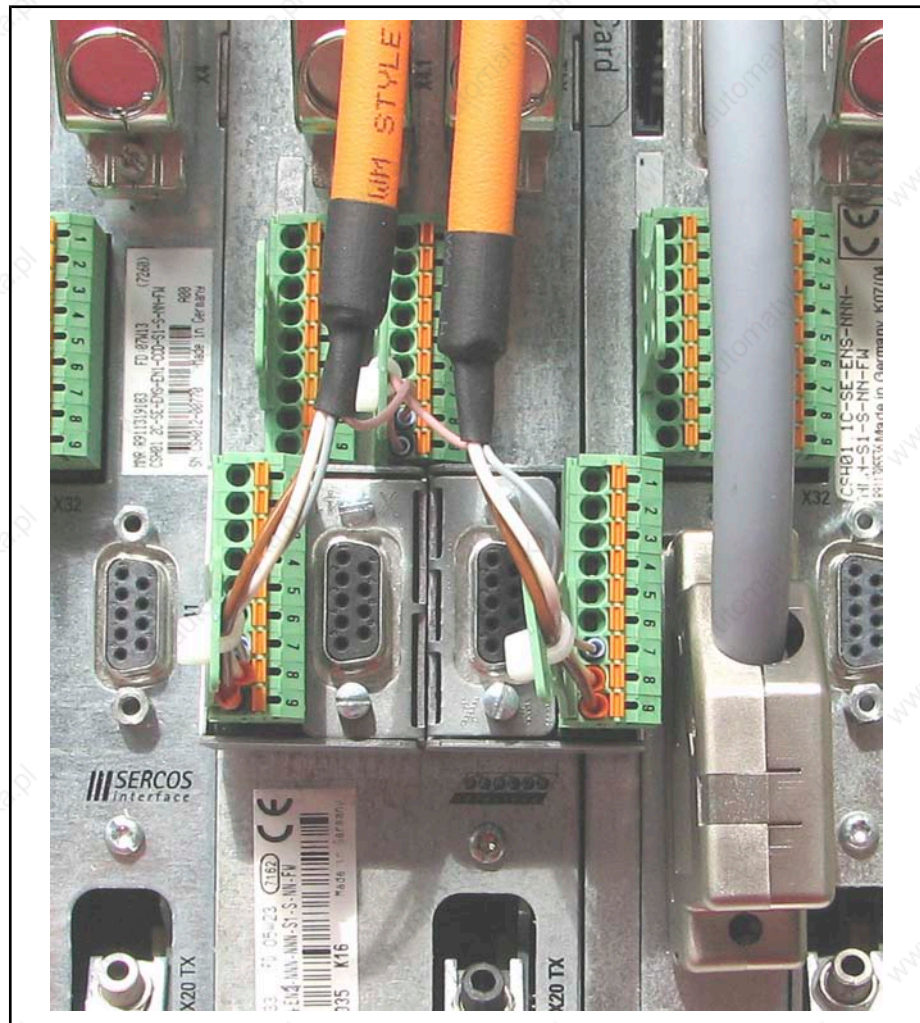

Fig.14-124: HAS05.1-007-NNL and HAS05.1-007-NNR at CDB control section

**Wiring Example With HAS05.1-007-NNR**

HAS05.1-007-NNR is the preferred adapter for the bus connection of several optional modules S1.



Accessories in the Drive System Rexroth IndraDrive

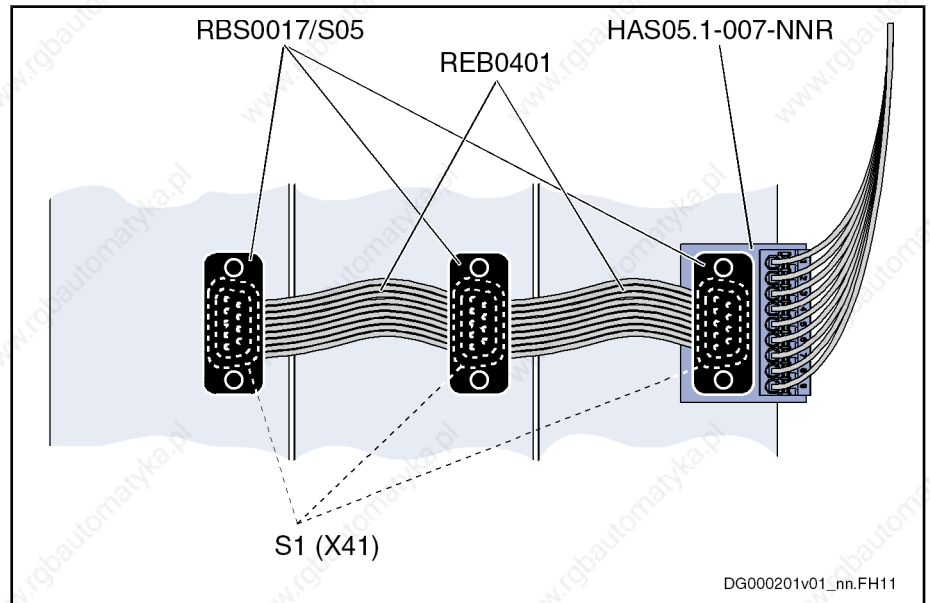

DG000201v01\_nn.FH11

RBS0017/ S05 D-Sub connector with connection for ribbon cable

REB0401 ribbon cable

Fig. 14-125: HAS05.1-007-NNR

At CSH01.1C control sections, the adapter HAS05.1-007-NNL can only be used at the left end of the bus connection, when option 3 has not been equipped.

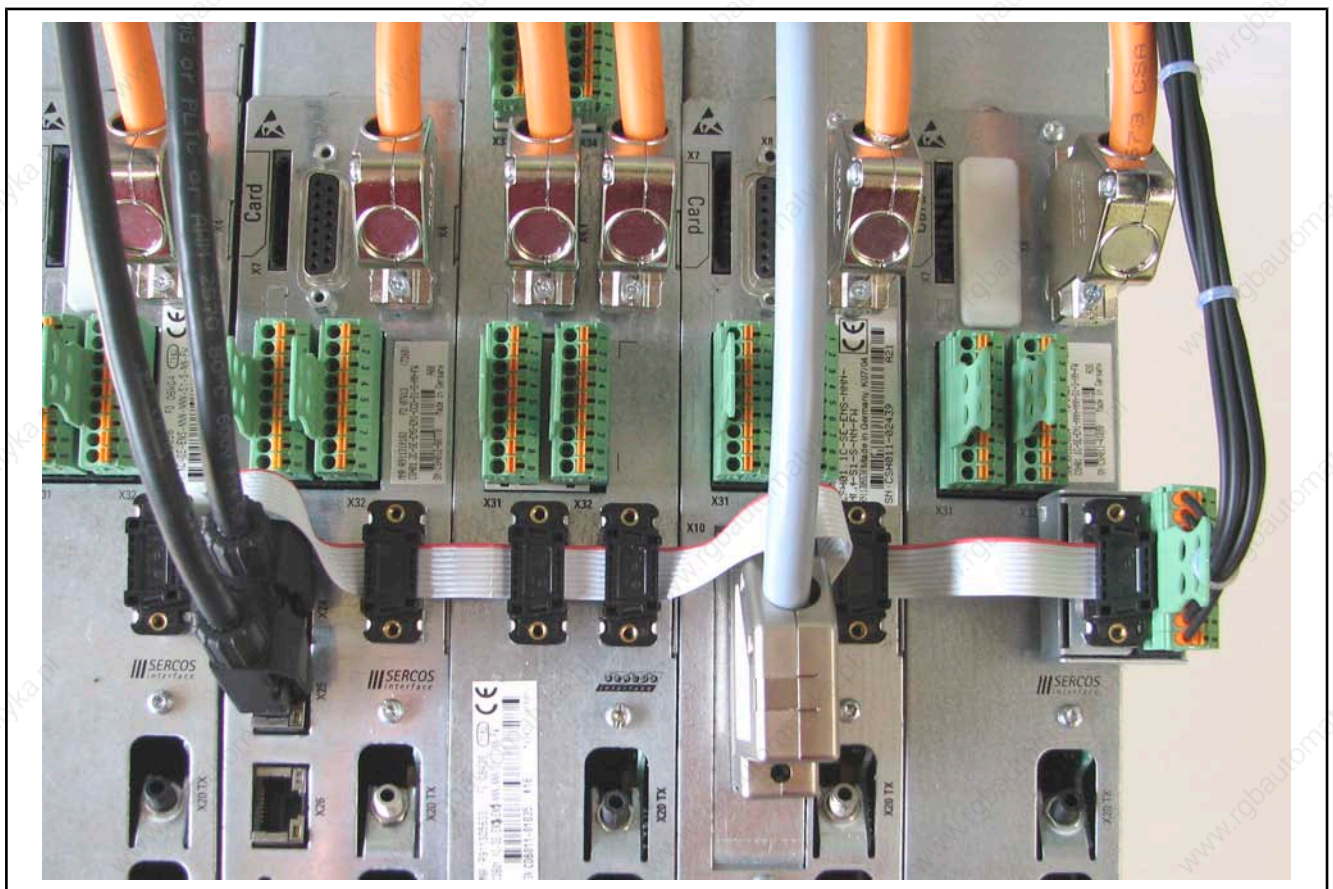

Fig. 14-126: HAS05.1-007-NNR, RBS0017/S05 and REB0401 for bus connection of optional modules S1 of the axes of one zone

Accessories in the Drive System Rexroth IndraDrive

## 14.5.10 HAS05.1-008, Adapter for Connecting two Cables

### Usage

**Assignment** The accessory HAS05.1-008 can be used at the following drive controllers:

- HCS03.1E-W0100...0210
- HMS01.1N-W0150...0210

**Function** With the accessory HAS05.1-008, you can connect two 16 mm<sup>2</sup> cables with ring cable lugs at the mentioned devices at terminal block X5 (motor connection), each at A1, A2 and A3.

**Scope of Supply** The accessory contains:

- 3 × adapter
- 3 × screw M6 × 25

Accessories in the Drive System Rexroth IndraDrive

<p>Made in Germany 109-1304-4803-00</p> <p style="text-align: right;"><b>Rexroth Bosch Group</b></p> <h2 style="text-align: center;">HAS05.1-008-NNN-NN</h2> <div style="text-align: center;">                   R911319898             </div> <table border="1" style="width: 100%; border-collapse: collapse; margin-top: 10px;"> <tr> <td style="width: 5%;">3</td> <td style="width: 45%;">KOMBI-SCHRAUBE</td> <td style="width: 35%;">Z1SO10644-M6X25-8.8 &amp;</td> <td style="width: 15%;">R911276873</td> </tr> <tr> <td>3</td> <td>ADAPTERBLECH HMS01.1-W0150 AS-BLOCK</td> <td></td> <td>R911319243</td> </tr> <tr> <td><b>Stck</b></td> <td><b>Benennung</b></td> <td></td> <td><b>MN</b></td> </tr> </table>		3	KOMBI-SCHRAUBE	Z1SO10644-M6X25-8.8 &	R911276873	3	ADAPTERBLECH HMS01.1-W0150 AS-BLOCK		R911319243	<b>Stck</b>	<b>Benennung</b>		<b>MN</b>	<p style="text-align: center;"><b>BEIPACKZETTEL HAS05.1-008-NNN-NN</b></p> <table border="1" style="width: 100%; border-collapse: collapse;"> <thead> <tr> <th style="width: 10%;">Stck</th> <th style="width: 70%;">Benennung</th> <th style="width: 20%;">MN</th> </tr> </thead> <tbody> <tr> <td style="text-align: center;">3</td> <td>ADAPTERBLECH HMS01.1-W0150 AS-BLOCK</td> <td style="text-align: center;">R911319243</td> </tr> <tr> <td></td> <td style="text-align: center;">   <span style="float: right;">1:1</span> </td> <td></td> </tr> <tr> <td style="text-align: center;">3</td> <td>KOMBI-SCHRAUBE Z1SO10644-M6X25-8.8 &amp;</td> <td style="text-align: center;">R911276873</td> </tr> <tr> <td></td> <td style="text-align: center;">   <span style="float: right;">1:1</span> </td> <td></td> </tr> </tbody> </table> <table border="1" style="width: 100%; border-collapse: collapse; margin-top: 10px;"> <tr> <td><b>Datum</b></td> <td>2006-12-18</td> <td><b>Benennung</b></td> <td></td> </tr> <tr> <td><b>Name</b></td> <td>rainhirt</td> <td colspan="2">BEIPACKZETTEL HAS05.1-008-NNN-NN</td> </tr> <tr> <td><b>Material-Nr.</b></td> <td>R911319900</td> <td><b>Zeich-Nr.</b></td> <td>109-1304-4203-00</td> </tr> <tr> <td><b>Datei</b></td> <td>08209292</td> <td><b>Ers.durch</b></td> <td>...</td> </tr> <tr> <td></td> <td></td> <td><b>AEM-Nr.</b></td> <td>...</td> </tr> </table>	Stck	Benennung	MN	3	ADAPTERBLECH HMS01.1-W0150 AS-BLOCK	R911319243		 <span style="float: right;">1:1</span>		3	KOMBI-SCHRAUBE Z1SO10644-M6X25-8.8 &	R911276873		 <span style="float: right;">1:1</span>		<b>Datum</b>	2006-12-18	<b>Benennung</b>		<b>Name</b>	rainhirt	BEIPACKZETTEL HAS05.1-008-NNN-NN		<b>Material-Nr.</b>	R911319900	<b>Zeich-Nr.</b>	109-1304-4203-00	<b>Datei</b>	08209292	<b>Ers.durch</b>	...			<b>AEM-Nr.</b>	...
3	KOMBI-SCHRAUBE	Z1SO10644-M6X25-8.8 &	R911276873																																														
3	ADAPTERBLECH HMS01.1-W0150 AS-BLOCK		R911319243																																														
<b>Stck</b>	<b>Benennung</b>		<b>MN</b>																																														
Stck	Benennung	MN																																															
3	ADAPTERBLECH HMS01.1-W0150 AS-BLOCK	R911319243																																															
	 <span style="float: right;">1:1</span>																																																
3	KOMBI-SCHRAUBE Z1SO10644-M6X25-8.8 &	R911276873																																															
	 <span style="float: right;">1:1</span>																																																
<b>Datum</b>	2006-12-18	<b>Benennung</b>																																															
<b>Name</b>	rainhirt	BEIPACKZETTEL HAS05.1-008-NNN-NN																																															
<b>Material-Nr.</b>	R911319900	<b>Zeich-Nr.</b>	109-1304-4203-00																																														
<b>Datei</b>	08209292	<b>Ers.durch</b>	...																																														
		<b>AEM-Nr.</b>	...																																														

Fig. 14-127: Accompanying note

## Accessories in the Drive System Rexroth IndraDrive

### Mounting

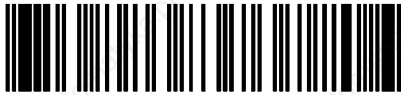
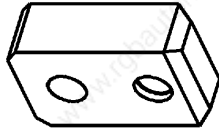
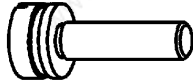
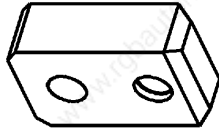
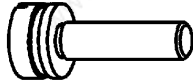
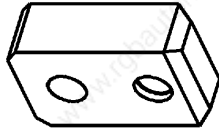
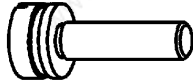
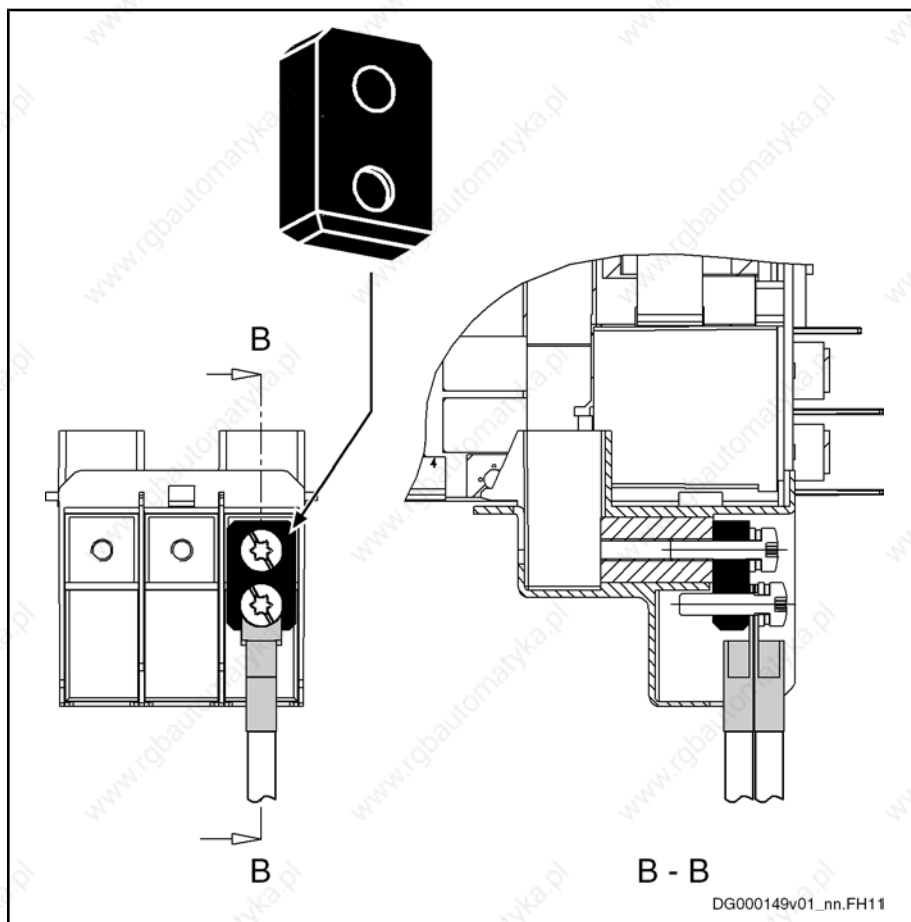

B - B transverse profile of connection

Fig. 14-128: HAS05.1-008 at an X5 connection point

1. Screw adapter to connection point with supplied screw.
2. Connect cable as shown and screw it on.
3. Repeat steps 1 and 2 for each connection point.

## 14.6 Fiber Optic Cable Connections

### 14.6.1 Overview of Types

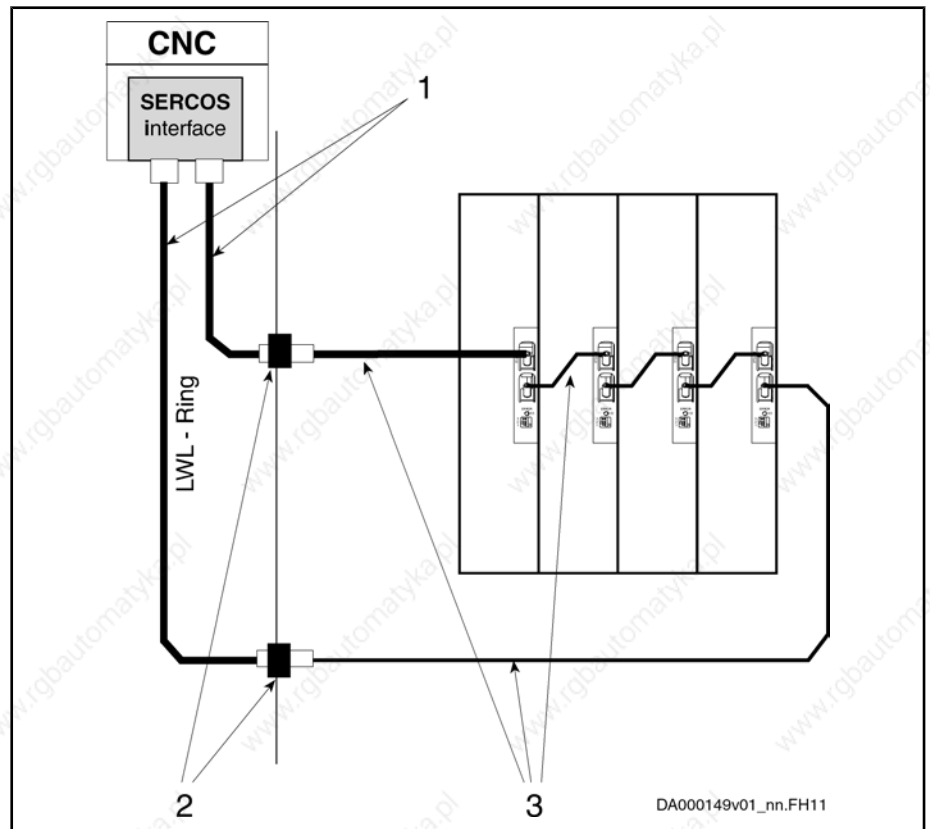

- 1 fiber optic cable connections outside of control cabinet
- 2 control cabinet duct
- 3 fiber optic cable connections inside of control cabinet

Fig. 14-129: Fiber optic cable connections

Installation location	Description	Type designation
outside of control cabinet	robust fiber optic cable connections from peripherals to control cabinet	RKO0101
at control cabinet	control cabinet duct with plug-in connectors	INS0610
inside of control cabinet	fiber optic cable connections to and between drive controllers	RKO0100

Fig. 14-130: Fiber optic cable connection elements



For ordering the fiber optic cable connection, you have to generate the complete order code containing details on type and length.

For the type designation see the above table and add the required length to it.

Determine the length by means of the list of different device arrangements.

Example of order code for arrangement HCS02 (left 105 mm) next to HCS02 (right 65 mm):

Accessories in the Drive System Rexroth IndraDrive

- required length: 0.25 m
- type designation: RKO0100
- order code: RKO0100 / 0,25

## 14.6.2 Interconnection of Drive Controllers

### General Information

For selecting the fiber optic cable connection of drive controllers, take different possible combinations and different device widths into account.

### Combination of HCS02 and HCS02

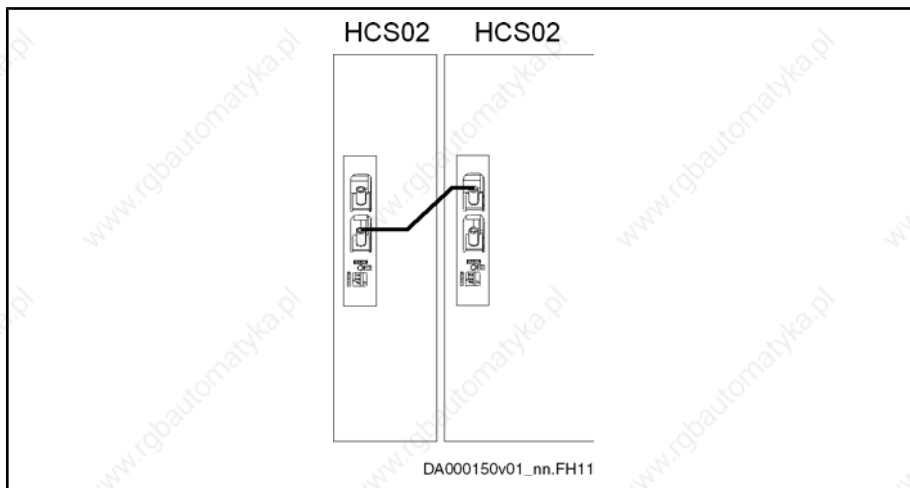

Fig.14-131: HCS02 with HCS02



For fiber optic cables from **CSB01.1N-SE** control sections to other control section types, take fiber optic cables which are **0.05 m** longer (at the devices, SERCOS connections are at different heights and sides).

Observe the routing guidelines and technical data (e.g. allowed bending radiuses) contained in documentation "Rexroth Connection Cables", DOK-CONNEC-CABLE\*LWL\*\*\_AW\*\*\_\*\*\_\*.

Required fiber optic cable length [m]		
Width left HCS02 [mm]	Width right HCS02 [mm]	
	65	105
65	0,15	0,15
105	0,25	0,25

Fig.14-132: Fiber optic cable lengths

Accessories in the Drive System Rexroth IndraDrive

Combination of HCS02 to the Right of HMS or HMD

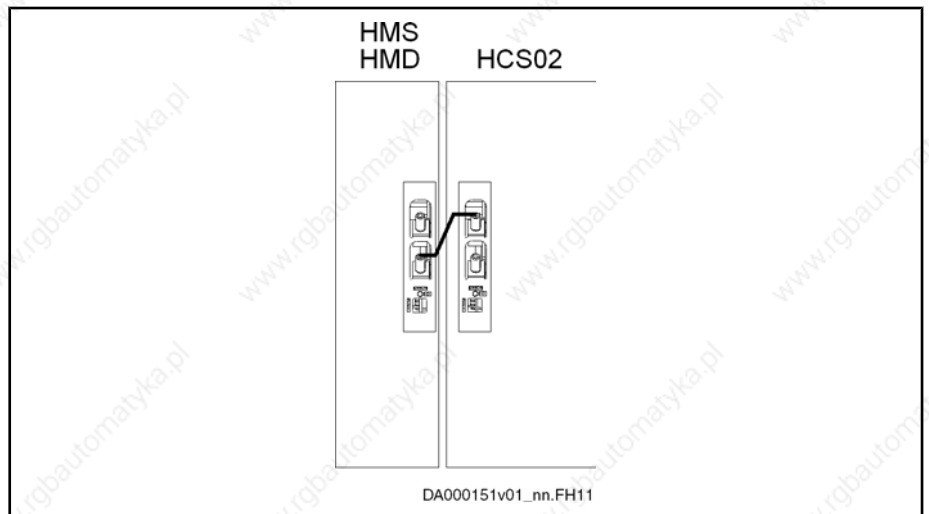

Fig. 14-133: HCS02 to the right of HMS or HMD  
Independent of the width of the devices, cable length is 0.15 m.

Combination of HCS02 to the Left of HMS or HMD

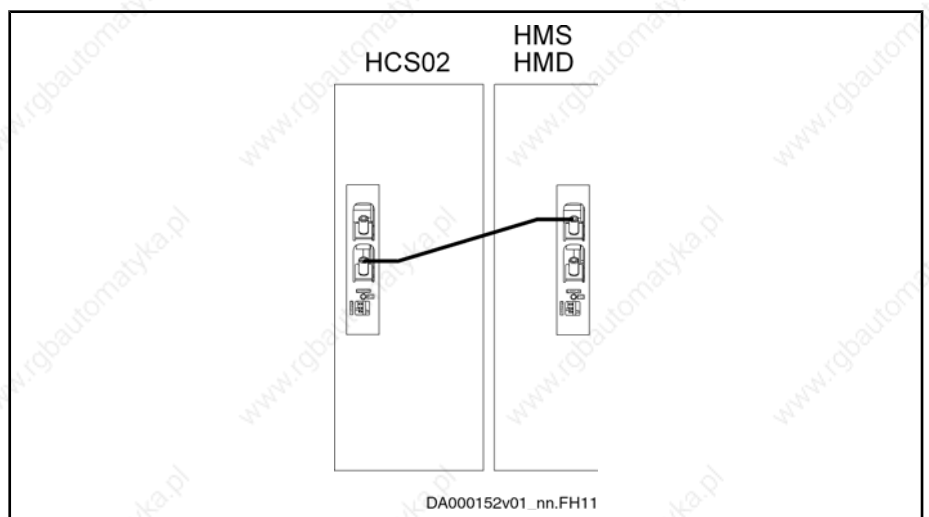

Fig. 14-134: HCS02 to the left of HMS or HMD



For fiber optic cables from **CSB01.1N-SE** control sections to other control section types, take fiber optic cables which are **0.05 m** longer (at the devices, SERCOS connections are at different heights and sides).

Observe the routing guidelines and technical data (e.g. allowed bending radiuses) contained in documentation "Rexroth Connection Cables", DOK-CONNEX-CABLE\*LWL\*\* -AW\*\* -\*\* -\*.

Cable length = width HCS02 + width HMS/HMD + 10 cm

Required fiber optic cable length [m]				
Width HCS02 [mm]	Width HMS / HMD [mm]			
	50	75	100	125



Accessories in the Drive System Rexroth IndraDrive

Required fiber optic cable length [m]				
65	0,25	0,25	--	--
105	0,25	0,30	0,30	0,30

Fig. 14-135: Fiber optic cable lengths

Combination of HCS03 to the Right of HMS or HMD

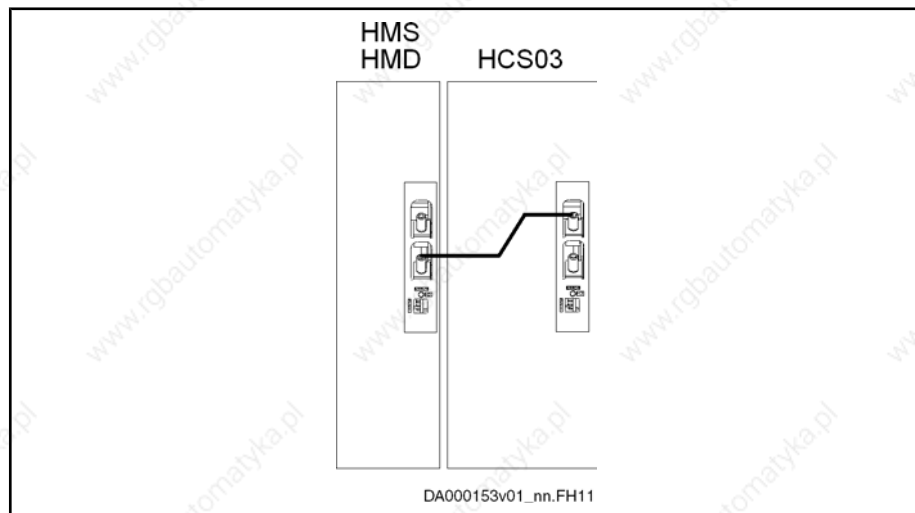

Fig. 14-136: HCS03 to the right of HMS or HMD

Combination of HCS03 to the Left of HMS or HMD

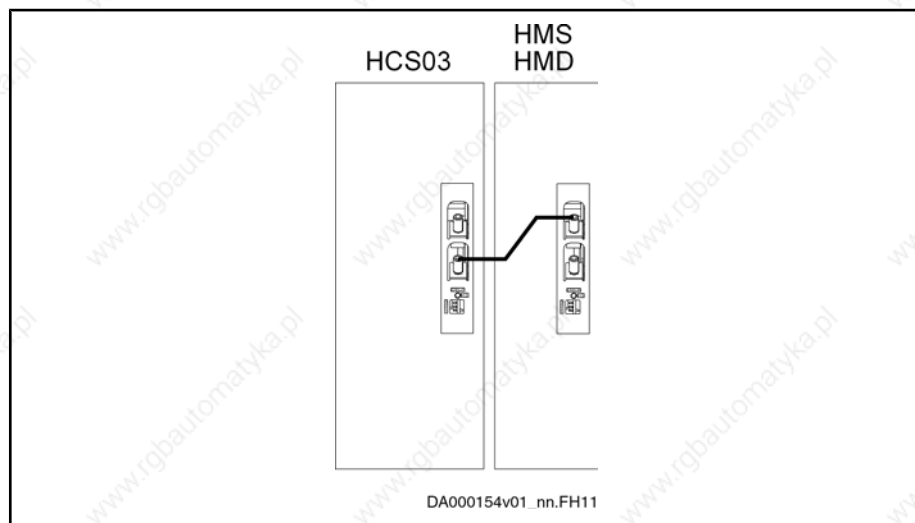

Fig. 14-137: HCS03 to the left of HMS or HMD



For fiber optic cables from **CSB01.1N-SE** control sections to other control section types, take fiber optic cables which are **0.05 m** longer (at the devices, SERCOS connections are at different heights and sides).

Observe the routing guidelines and technical data (e.g. allowed bending radiuses) contained in documentation "Rexroth Connection Cables", DOK-CONN-EC-CABLE\*LWL\*\*\_AW\*\*\_\*\*\_\*.

## Accessories in the Drive System Rexroth IndraDrive

Required fiber optic cable length [m]								
Width left device [mm]	Width right device [mm]							
	50	75	100	125	150	200	225	350
50	0,15	0,25	0,25	0,25	0,30	0,50	0,50	0,50
75	0,15	0,25	0,25	0,25	0,30	0,50	0,50	0,50
100	0,15	0,25	0,25	0,25	0,30	0,50	0,50	0,50
125	0,15	0,25	0,25	0,25	0,30	0,50	0,50	0,50
150	0,15	0,25	0,25	0,25	0,30	0,50	0,50	0,50
200	0,15	0,25	0,25	0,25	0,30	0,50	0,50	0,50
225	0,15	0,25	0,25	0,25	0,30	0,50	0,50	0,50
350	0,15	0,25	0,25	0,25	0,30	0,50	0,50	0,50

Fig. 14-138: Fiber optic cable lengths

## 14.7 RKB0001, Extension for Module Bus Connections

### 14.7.1 Usage

**Assignment** The extension **RKB0001** can be used at:

- HMV01.1E
- HMV01.1R
- HMS01.1N
- HMD01.1N
- HMV02.1R
- HMS02.1N
- HCS03.1E-W0070, -W0100; -W0150



The extension RKB0001 cannot be used at HCS02 drive controllers.

**Function**

With the accessory RKB0001 you can extend the module bus connection between devices, when the distance between the drive controllers is greater than 5 mm (e.g. in the case of multiple-line arrangement).

**Lengths That can be Ordered, Order Code**

Lengths: 0.5 m to 40 m (in steps of 0.5 m)

Parts:

- housing with hinged cover
- cable with strain relief mounted at both ends

Indicate the complete order code for your order.

Example:

- required length: 2.5 m
- type designation: RKB0001
- order code: **RKB0001 / 02,5**

Accessories in the Drive System Rexroth IndraDrive

### 14.7.2 Mounting

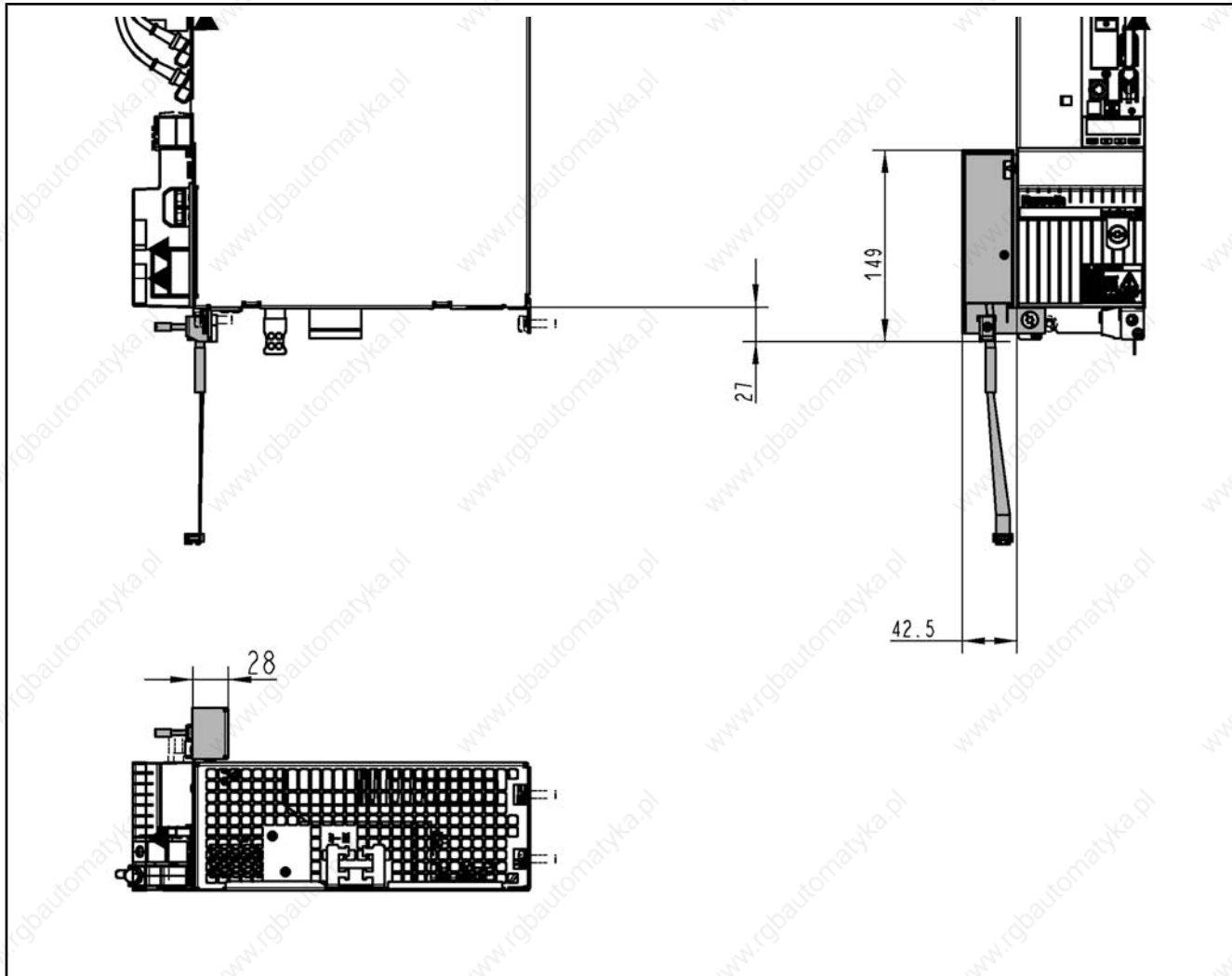

Fig.14-139: Dimensions RKB0001

## Accessories in the Drive System Rexroth IndraDrive

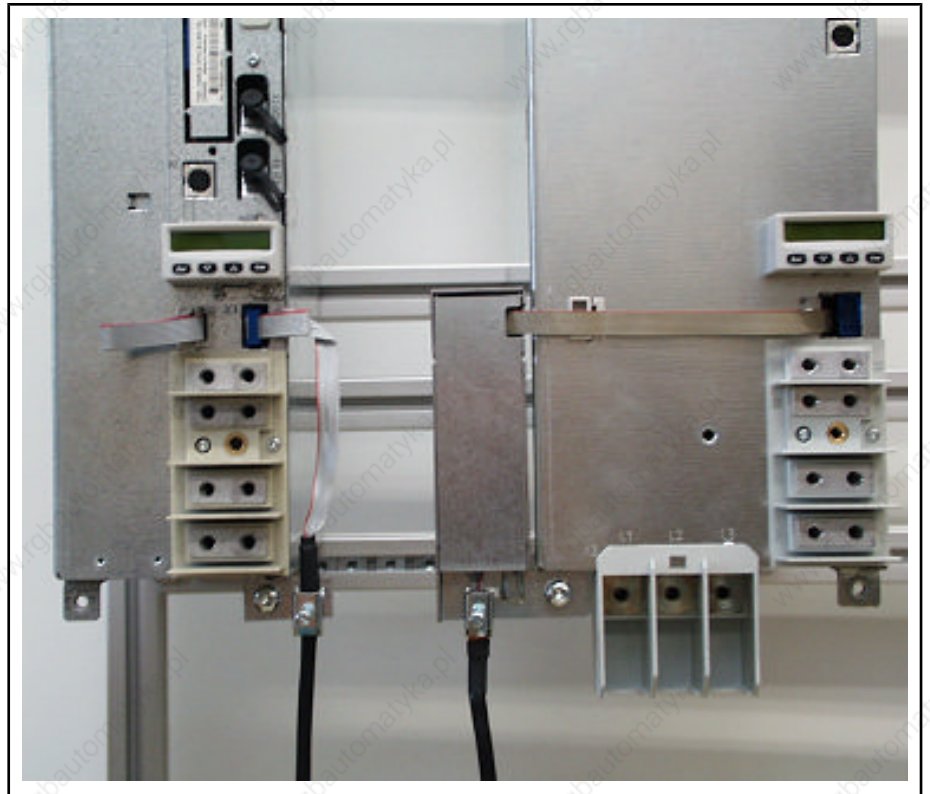

Fig. 14-140: Extension of module bus

*Mounting RKB bus cable*

1. Mount housing to point of connection for equipment grounding conductor.
2. Open cover and plug ribbon cable of right device into circuit board.
3. Close cover.
4. Screw strain relief down to point of connection for equipment grounding conductor.
5. Plug ribbon cable into X1.



Make sure the connection between strain relief and point of connection for equipment grounding conductor is well conductive.

By means of appropriate wiring, establish equipment grounding connections of devices that are not directly adjoining.



## 15 Third-Party Motors at IndraDrive Controllers

### 15.1 General Information on Third-Party Motors

#### 15.1.1 Why Use Third-Party Motors at IndraDrive?

Today machine axes are mainly moved with electric drives. Motors of standard design are used in most cases as this is the most cost-efficient solution.

##### Special Requirements

Due to special requirements at machine axes, constructional or safety-related aspects, it may be necessary for the machine manufacturer to use a motor construction diverging from the standard.

##### Motor Design not Included in Product Range

For these cases there is the demand on the drive supplier to realize drives with motors that are not included in his own product range due to the special design.

##### Check Before Using Third-Party Motors

At drive controllers of the Rexroth IndraDrive range, it is possible to use third-party motors. For this purpose, check whether the third-party motor complies with the requirements of use.

#### 15.1.2 Which are the Important Directives?

According to the legal regulations (EU Directive EMC 89/336/EEC and the German EMC laws), installations and machines must be designed and built in accordance with the present state-of-the-art of standardization.

In order to comply with the machine directives regarding "electromagnetic compatibility (EMC)", a conformity test of the drive system (motor with controller and connection design) has to be carried out. The test of the drive system and compliance with the directives have to be guaranteed by the machine manufacturer.

#### 15.1.3 Third-Party Motors to be Controlled

##### Motor Types

The following motor types can be controlled:

- asynchronous motors, rotary
- asynchronous motors, linear
- synchronous motors, rotary
- synchronous motors, linear

These motors can be operated within the scope of the technical data of the selected Rexroth IndraDrive controller. If motors have been provided with a holding brake, it should be controlled via the drive controller. Make sure that the relevant technical data of the motor holding brake are complying with those of the holding brake output.



For third-party motors Bosch Rexroth, as a matter of principle, does not assume the guarantee for the power data at the motor shaft!

##### Synchronous Motors

In the case of synchronous motors, the commutation offset has to be set during commissioning. The drive firmware provides several methods for determining this offset so that it is possible to determine the value for different motor characteristics.

## Third-Party Motors at IndraDrive Controllers



Observe the restrictions in conjunction with the commutation offset determination when using synchronous motors! See firmware documentation chapter "Drive Control", "Motor Control: Commutation Setting".

Possibly available reluctance property cannot be used for synchronous third-party motors! For third-party motors, it is impossible to determine fail-safe motor parameter values for using the reluctance property. The respective bit of "P-0-4014, Type of construction of motor" therefore mustn't be set!

## 15.2 Requirements on Third-Party Motors

### 15.2.1 General Information

For successful and fail-safe use of a third-party motor, check

- whether the third-party motor to be controlled satisfies the voltage loads
- which controller, including supply, is suitable due to the motor power to be delivered
- whether the third-party motor has the required minimum inductance
- whether the motor can be protected against inadmissible temperature rise in the case of overload (temperature evaluation)
- whether the mounted position measuring system can be evaluated by the drive controller or which position measuring system can be selected for kit motors

### 15.2.2 Voltage Load of the Third-Party Motor

The voltage load of the insulation system of a motor occurring in practical application is mainly influenced by the following characteristics:

- the output variables of the drive controller which is used (feed the transmission distance)
- cable parameters depending on cable design and length (determine the properties of the transmission distance, such as attenuation)
- the motor design regarding capacitive and inductive properties (from the end of the transmission distance)

As a result of the variables, the insulation system of the third-party motor, as regards voltage, is loaded by the following values:

- peak voltage  $U_{pp}$  and
- voltage change  $dv/dt$

The occurring peak voltages at the motor are caused by reflections in the motor cable. The insulation of the motor is thereby loaded with other peak voltages and voltage changes than the ones occurring at the output of the power section.



Determine the occurring voltage load at the **terminals** of the third-party motor in the application with all involved components.

#### Using the HMF Motor Filter

Use voltage-reducing components (e.g. motor filter HMF), if one of the following criteria applies:

- allowed voltage change ( $dv/dt$ ) of third-party motor: **< 5 kV/μs**
- allowed peak voltage (crest value) of third-party motor between phase-phase and phase-housing: **< 1500 V**
- Both values (voltage change, peak voltage) are influenced by:



## Third-Party Motors at IndraDrive Controllers

- **Mains voltage:**  
The higher the mains voltage at which the drive system is operated, the higher the value of the voltage change and the occurring peak voltage.
- **Length and electrical properties of the motor cable:**  
The shorter the motor cable, the less the attenuation effects.  
The longer the motor cable, the higher the degree of voltage overshoot at the motor-side cable end.
- For a motor cable length  $l < 25 \text{ m}$  and mains voltage  $U_{N3} > \text{AC } 440 \text{ V}$ , it is recommended that you use voltage-reducing components.



Apart from the nominal current  $I_N$ , especially take the maximum allowed switching frequency of the power output stage ( $f_s$ ) into account with which the motor filter HMF may be operated.

Verify the success of the voltage-reducing measures.

### 15.2.3 Minimum Inductance of Third-Party Motor

Depending on the drive controller used, the motor has to have a minimum value for inductance. The actually available inductance of a motor can be measured directly between two motor terminals by means of an inductance measuring bridge. The measurement has to be made for a complete motor wired for normal operation but not yet connected. During the measurement one motor terminal remains open! For asynchronous motors, the measured value can only be used if the rotor doesn't have closed slots!

Drive controller	Minimum required motor inductance
HCS at 3 × AC 230 V	$L_{U-V} = 60 \times 4 / (\sqrt{2} \times I_{Typ} \times f_s)$ (in mH)
HMS, HMD at HMV (3 × AC 400 V) HMS, HMD at HCS (3 × AC 400 V)	$L_{U-V} = 80 \times 4 / (\sqrt{2} \times I_{Typ} \times f_s)$ (in mH)
HMS, HMD at HMV (3 × AC 480 V) HMS, HMD at HCS (3 × AC 480 V)	$L_{U-V} = 116 \times 4 / (\sqrt{2} \times I_{Typ} \times f_s)$ (in mH)

$I_{Typ}$  maximum current of drive controller according to type code (rms value)  
 $f_s$  desired switching frequency in kHz

*Fig. 15-1: Minimum inductances depending on drive controller data, supply units and supply voltage*

Install a three-phase choke in the motor feed wire, if the inductance of the third-party motor is smaller than indicated in the table above. This choke has to increase the inductance that can be measured between two motor terminals to the minimum value.



When the inductance is measured, different inductance values can be determined at different rotor positions within one pole pair distance of the motor. The average value is relevant for the check of the minimum value.

Correct values can only be determined when the motor is **in standstill!**

Third-Party Motors at IndraDrive Controllers

Available third-party motor	Planned third-party motor
 <p style="text-align: center;"><math>3 \times L_{Dr}</math></p> <p style="text-align: right; font-size: small;">DA000111v01_nn.fh11</p> <p><math>L_{Dr} = 0,5 \times (L_{U-Vmin} - L_{U-V})</math> (inductance measurement with 1 kHz)</p> <p><i>Fig. 15-2: mounting of 3 x LDr (three-phase choke)</i></p>	<p>Calculate the leakage inductance (asynchronous motor) or inductance (synchronous motor) of the third-party motor by means of the single-phase equivalent circuit diagram (manufacturer's specification!).</p> <p>Determine choke by means of calculation, if necessary. It is recommended that you contact Bosch Rexroth!</p>
<p>Requirements on the choke:</p> <ul style="list-style-type: none"> <li>• <math>I_{n\_Dr} \geq I_{n\_Mot}</math> The rated current of the choke has to be greater than or equal to the rated motor current.</li> <li>• Depending on the maximum speed, the choke is loaded with the respective output frequency and the PWM frequency of the drive controller.</li> <li>• The insulation class has to correspond at least to that of the motor or has to be dimensioned for higher temperatures.</li> <li>• The voltage load of the choke depends on the drive controller used.</li> </ul>	

Fig. 15-3: Data for possibly required choke

## 15.2.4 Temperature Evaluation of Third-Party Motor

Only operate such motors with incorporated temperature sensor at IndraDrive controllers so that the motor can be thermally monitored by the controller and protected against destruction by too high temperature rise (see "P-0-0512, Temperature sensor").

When, in exceptional cases, you want to operate third-party motors without temperature sensor at IndraDrive controllers, you must determine the thermal time constants of motor housing (P-0-4035) and motor winding (P-0-4034, P-0-4037). By means of its temperature model, the firmware can correctly reflect the cooling situation of the motor.

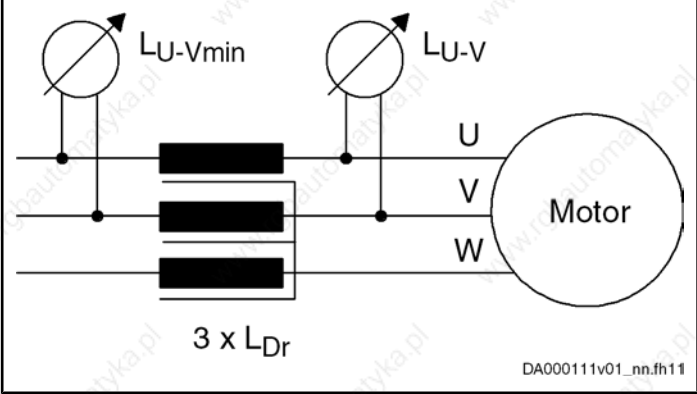

In case the motor housing or blower is dirty, this worsens the cooling situation of the motor and protection against thermal overload is therefore insufficient!

## 15.3 Requirements on the Encoder of the Third-Party Motor

### 15.3.1 Motor Encoder of Asynchronous Third-Party Motor

Asynchronous motors can also be controlled by IndraDrive controllers in "open-loop" operation (without motor encoder). In "closed-loop" operation (with motor encoder), a relative measuring system is sufficient for asynchronous motors.

### 15.3.2 Motor Encoder of Synchronous Third-Party Motor

For fail-safe drives with synchronous third-party motors at IndraDrive controllers, the following possible combinations or restrictions have to be taken into account when selecting the measuring system:

## Third-Party Motors at IndraDrive Controllers

Drive range	Motor measuring system	Synchronous third-party motor
IndraDrive	absolute	■
	relative	□

- advantageous combination
- Combination is possible (restrictions specific to application), commissioning may be more complicated!

Fig. 15-4: Possible combinations of synchronous third-party motor and motor measuring system



The control section integrated in the drive controller can evaluate measuring systems as a motor encoder, if they are contained in "P-0-0074, Encoder type 1 (motor encoder)" (see also Project Planning Manual "Rexroth IndraDrive Drive Controllers Control Sections").

For information on absolute and relative measuring systems, see section "Measuring Systems" of firmware documentation!

### 15.3.3 Motor Encoder Resolver - Notes on Selection

For operating "resolver" encoder types, there is the optional module EN1 available (see also Project Planning Manual "Rexroth IndraDrive Drive Controllers Control Sections").

Observe:

- data of resolver system to be compared must be available at 4 kHz
- ratio
- current consumption
- DC resistance of stator
- No. of poles
- phase shift

You can get more detailed information on request.

## 15.4 Notes on Selection and Commissioning

### 15.4.1 Selecting the Controller as Regards Continuous Current

The drive controller required for the respective motor and the supply unit are determined by comparing the motor data to the data of these devices (see Project Planning Manual "Rexroth IndraDrive Supply Units and Power Sections").



The continuous current of the controller should be greater than the one of the motor. The continuous power of the supply must be greater than the sum of all average powers of the axes of the drive system!

### 15.4.2 Selecting the Connection Technique

For the available power and encoder cables, see documentation "Rexroth Connection Cables" (DOK-CONN-CABLE\*STAND-AU...).

Third-Party Motors at IndraDrive Controllers

### 15.4.3 Notes on Commissioning



For further information, notes on commissioning and supporting documents (e.g. forms for entering the required data) see firmware documentation.

---

## 16 Calculations

### 16.1 Determining the Appropriate Drive Controller

#### 16.1.1 Introduction

Supply for the drive system Rexroth IndraDrive takes place by means of compact HCS converters or HMV supply units. According to drive task, design of drive controller and operating conditions, you can in addition use chokes, additional capacitors, braking resistors, transformers etc.

The drive controller or supply unit has to supply the DC bus continuous power and for acceleration the DC bus peak power. With regenerative operation, they must be able to absorb the continuous recovery power and peak recovery power.

Before the drive controller or supply unit and the additional components can be selected, the motors and drive controllers to be used must be defined.

To ensure correct dimensioning of the drive system, you should do the calculations as described in the following sections.

#### 16.1.2 DC Bus Continuous Power

The DC bus continuous power is calculated from the mechanical power, taking the following aspects into consideration:

- motor and controller efficiency
- simultaneity factors

##### Mechanical Power

$$P_m [W] = M \times \omega = \frac{M \times n \times 2\pi}{60}$$

$$P_m [kW] = \frac{M \times n}{9550}$$

$P_m$	mechanical power
$M$	torque [Nm]
$\omega$	angular velocity [min <sup>-1</sup> ]
$n$	motor speed [min <sup>-1</sup> ]

Fig. 16-1: Mechanical power

##### Mechanical Continuous Power for Servo Drives

To calculate the mechanical continuous power of a servo drive, you need the effective motor torque and the average motor speed.

The effective motor torque can be taken over from the servo drive calculation. The average motor speed is determined as follows.

##### Average Motor Speed

For servo drive tasks at common NC machine tools, the average motor speed is approx. 25% of the rapid traverse speed. In some cases, however, this rough estimation is not sufficient. An exact calculation of the average motor speed is required.

##### Average Speed with Run-Up and Braking Times not Taken into Account

If the period during which the motor is run at constant speed is significantly greater than the run-up and braking time, the following applies:

Calculations

$$n_{av} = \frac{n_1 \times t_1 + n_2 \times t_2 \dots + n_n \times t_n}{t_1 + t_2 \dots + t_n}$$

$n_{av}$  average motor speed [min-1]  
 $n_1 \dots n_n$  motor speed [min-1]  
 $t_1 \dots t_n$  duty cycle [s]

Fig.16-2: Average speed; effects of run-up and braking times not taken into account

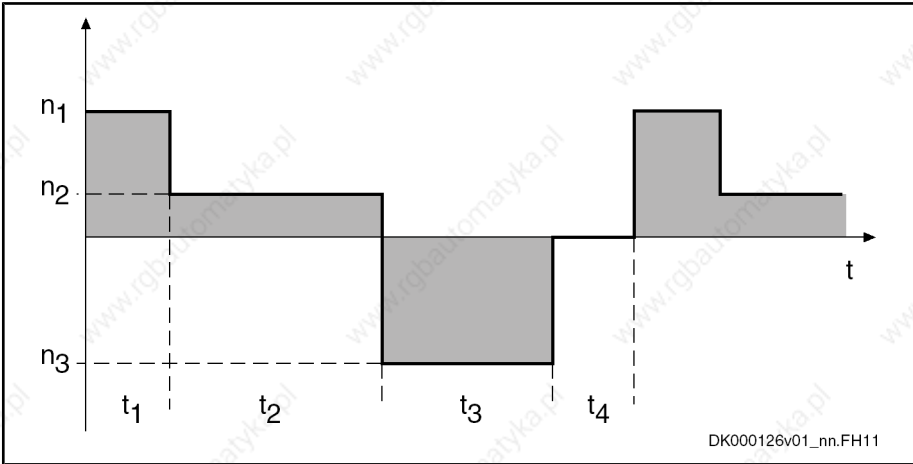

Fig.16-3: Speed characteristic; effects of run-up and braking times not taken into account

In dynamic applications with short cycle times, e.g. roll feeds and nibbling machines, run-up and braking times must be taken into account.



**CAUTION**

**Damage to the drive controller!**

- The DC bus capacitors in the drive controller have been dimensioned for loading with continuous power.
- If loaded with cyclic charging and discharging processes of high energy content, the DC bus capacitors can be overloaded, especially with decreasing mains connection voltage.

Operate additional capacitors at the DC bus.

**Average Speed with Run-Up and Braking Times Taken into Account**

$$n_{av} = \frac{\frac{n}{2} \times t_H + n \times t_1 + \frac{n}{2} \times t_B}{t_H + t_1 + t_B + t_2}$$

$n_{av}$  average motor speed [min-1]  
 $n$  motor speed [min-1]  
 $t$  time [s]  
 $t_H$  run-up time [s]  
 $t_B$  braking time [s]

Fig.16-4: Average speed; effects of run-up and braking times taken into account

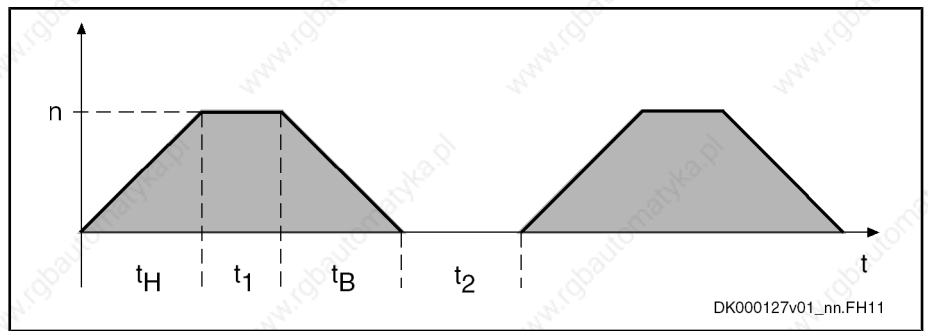

Fig. 16-5: Average speed; effects of run-up and braking times taken into account

**Mechanical Power for Servo Drives**

$$P_{mSe} = \frac{M_{eff} \times n_{av}}{9550}$$

$P_{mSe}$  mechanical continuous power for servo drives [kW]  
 $M_{eff}$  effective motor torque [Nm]  
 $n_{av}$  average motor speed [min<sup>-1</sup>]

Fig. 16-6: Mechanical power for servo drives

**Mechanical Power for Main Drives**

Main drives are drives which are mainly used in the constant power speed range. Thus, nominal power is decisive for dimensioning the mains supply. The mechanical nominal power of the main drives can be taken from the operating characteristic or calculated from nominal speed and nominal torque.

$$P_{mHn} = \frac{M_n \times n_n}{9550}$$

$P_{mHn}$  mechanical nominal power for main drives (shaft output) [kW]  
 $M_n$  nominal motor torque [Nm]  
 $n_n$  nominal motor speed [min<sup>-1</sup>]

Fig. 16-7: Mechanical power for main drives

**DC Bus Continuous Power for Servo Drives**

The drive controller or the combination of drive controllers has to make available the DC bus power. However, in most applications, simultaneous loading of all drives will not occur; thus, only the simultaneous load must be considered for calculating the DC bus continuous power to be made available for servo drives. To calculate the DC bus continuous power to be made available for typical NC feed axes at machine tools, inclusion of a so-called simultaneity factor has proved to be favorable in practical application:

<b>Number of axes</b>	1	2	3	4	5	6	7	$n = n + 1$
<b>Simultaneity factor (<math>F_G</math>)</b>	1	1,15	1,32	1,75	2,0	2,25	$F_G = 2,5$	$F_{Gn} = F_G + 0,25$

Fig. 16-8: Simultaneity factors



Calculations

$$P_{ZWDSe} = \frac{(P_{mSe1} + P_{mSe2} \dots + P_{mSen}) \times 1,25}{F_G}$$

$P_{ZWDSe}$  DC bus continuous power for servo drives [kW]  
 $P_{mSe1} \dots P_{mSen}$  mechanical continuous power for servo drives [kW]  
 $F_G$  simultaneity factor  
 1,25 constant for motor and controller efficiency  
*Fig. 16-9: DC bus continuous power for servo drives*

**DC Bus Continuous Power for Main Drives**

If several main drives are operated at one DC bus, the simultaneously required DC bus continuous powers must be added:

$$P_{ZWHa} (P_{mHa1} + P_{mHa2} \dots + P_{mHan}) \times 1,25$$

$P_{ZWHa}$  DC bus continuous power for main drives [kW]  
 $P_{mHa1} \dots P_{mHan}$  mechanical continuous power for main drives [kW]  
 1,25 constant for motor and controller efficiency  
*Fig. 16-10: DC bus continuous power for main drives*

Chokes and additional capacitors have to be selected according to the actually required DC bus continuous power. It is determined by the nominal power of the main drives.



When selecting the drive controllers, make sure that their maximum DC bus continuous power will not restrict the short-time operation power of the main drives.

**DC Bus Continuous Power for Main and Servo Drives**

When main and servo drives are operated at a drive controller, the required DC bus continuous powers must be added.

At a typical NC machine tool, the required DC bus continuous power will be primarily defined by the main drive. Accordingly, the following equation is to be used for such applications:

$$P_{ZWD} = [P_{mHa} + 0,3 \times (P_{mSe1} + P_{mSe2} \dots + P_{mSen})] \times 1,25$$

0,3 experimental value for standard machine tools  
 1,25 constant for motor and controller efficiency  
 $P_{ZWD}$  DC bus continuous power [kW]  
 $P_{mSe1} \dots P_{mSen}$  mechanical continuous power for servo drives [kW]  
 $P_{mHa}$  nominal power for main drive (shaft output) [kW]  
*Fig. 16-11: DC bus continuous power for main and servo drives at NC machine tools*

$$\sum P_{ZWD, Anlage} \leq \sum P_{ZWD, Geräte}$$

$P_{ZWD, Anlage}$  generated DC bus continuous power of the installation  
 $P_{ZWD, Geräte}$  allowed DC bus continuous power of the devices  
*Fig. 16-12: Supply condition: DC bus continuous power*

**16.1.3 DC Bus Peak Power**

The drive controller or combination of drive controllers has to produce DC bus peak power for example when several axes of a machine tool simultaneously accelerate to rapid traverse rate after a tool change, approaching the work-piece.

**CAUTION****Damage due to supply unit overload!**

To avoid damage to the drive controller the sum of peak powers of all drives mustn't exceed the DC bus peak power of the supplying drive controller (central supply).

$$P_{ZWS} = \frac{(M_{NC} \pm M_G) \times n_{eil} \times 1,25}{9550}$$

$M_{NC}$	acceleration torque in the drive [Nm]
$M_G$	torque due to weight for vertical axes [Nm]
$n_{eil}$	speed at rapid traverse rate [min-1]
$P_{ZWS}$	DC bus peak power [kW]
1,25	constant for motor and controller efficiency
<i>Fig. 16-13:</i>	<i>DC bus peak power per drive</i>

$$\sum P_{ZWS, Anlage} \leq \sum P_{ZWS, Geräte}$$

$P_{ZWS, Anlage}$	generated DC bus peak power of the installation
$P_{ZWS, Geräte}$	allowed DC bus peak power of the devices
<i>Fig. 16-14:</i>	<i>Supply condition: DC bus peak power</i>

**16.1.4 Regenerative Power**

When all main and servo drives connected to a drive controller or combination of drive controllers brake simultaneously, the generated regenerative power must not be greater than the maximum regenerative power of the drive controller or combination of drive controllers. If this is not taken into consideration in dimensioning the system, thermal destruction of the braking resistors in the drive controllers may occur.

**CAUTION****Destruction due to braking resistor overload!**

Do the project planning for drive controllers or combinations of drive controllers in such a way that the resulting regenerative power can be absorbed when all main and servo drives connected to the drive controller or combination of drive controllers brake simultaneously.

$$W_{rot} = \frac{J_G}{2} \times \left( n_{eil} \times \frac{2\pi}{60} \right)^2$$

$W_{rot}$	rotary energy [Ws]
$n_{eil}$	speed at rapid traverse rate [min-1]
$J_G$	motor inertia and load inertia reduced to the motor shaft [kgm <sup>2</sup> ]
<i>Fig. 16-15:</i>	<i>Regenerative power per drive</i>

$$\sum W_{R, Anlage} \leq \sum W_{R, Geräte}$$

$W_{R, Anlage}$	generated regenerative power of the installation
$W_{R, Geräte}$	allowed regenerative power of the devices
<i>Fig. 16-16:</i>	<i>Supply condition: regenerative power</i>

## Calculations

**Influence of efficiency**

The energy absorption occurring in the steady-state condition in the majority of cases is less than the calculated energy absorption, because all involved components (such as load, gear, motor, cables) absorb a part of the regenerative power.

Only reduce the generated regenerative power when the efficiency behavior is known.

**Energy Absorption of Braking Resistor**

Within the minimum cycle time  $T_{cycl}$ , the braking resistor dissipates the electrically absorbed energy to its environment as heat. The braking resistor makes available the energy absorption during its duty cycle. The energy absorption is calculated as follows:

$$W_R = t_{on} \times P_{BS}$$

$$W_R \approx P_{BD} \times (T_{cycl} - t_{on})$$

$W_R$	absorbed regenerative power
$t_{on}$	allowed duty cycle
$P_{BS}$	allowed peak power of braking resistor
$P_{BD}$	allowed continuous power of braking resistor
$T_{cycl}$	allowed cycle time

Fig. 16-17: Energy absorption of braking resistor

**Energy absorption capacity with long cycle times**

For cycles with " $T > 5 \times T_{cycl}$ ", the indicated maximum regenerative power to be absorbed  $W_{R\_max}$  can be used.

**Several braking resistors (e.g. HLR) at common DC bus**

With several braking resistors at the DC bus, the available energy absorption is determined as the sum of the individual energy absorptions. For this purpose, the same switch-on threshold must take effect for all involved braking resistors.

**Adjustment of switch-on threshold!**

For the adjustment of the switch-on threshold, see also the following parameters:

- P-0-0833, Braking resistor threshold
- P-0-0858, Data of external braking resistor

### 16.1.5 Reduction of Generated Power Dissipation - Additional External Capacitors at DC Bus

When the drive brakes, the rotary energy present in the mechanical system is released as regenerative power in the DC bus of the drive controller or combination of drive controllers. It can

- be converted into dissipation heat via the braking resistor integrated in the drive controller or the additional braking resistor

or

- be stored as energy in the drive controllers and possibly available additional capacitors and reused for following acceleration processes. This

reduces the power dissipation generated in the control cabinet and lowers the energy consumption.

The following applies to successful use of additional capacitors to avoid unnecessary power dissipation in the control cabinet:

$$\sum W_{R, Anlage} \leq \sum W_{ZW, Geräte}$$

$W_{R, Anlage}$  generated regenerative power of the installation

$W_{ZW, Geräte}$  storable energy of the DC bus capacitors

Fig. 16-18: Condition to avoid power dissipation from the regenerative power

### Additional Capacitors as Energy Stores

Many acceleration and deceleration processes are typical for applications with servo drives (e.g. nibbling machines or roll feeds). This is why it can be useful for such applications to connect additional capacitors to the DC bus of the drive controllers. This provides the following advantages:

- For drive controllers without mains regeneration function this prevents the braking resistor in the drive controller from being switched on when the drives brake. The dissipation heat in the control cabinet is considerably reduced.
- The energy stored in the DC bus capacitors can be used for acceleration. The energy demand of the installation is reduced.

### Storable Energy in DC Bus

The specific energy absorption capacity of the drive controllers can be determined with the formula below.

$$W_{DC} = \frac{(C_{DC} + C_{DCext})}{2} \times (U_{R\_DC\_On}^2 - U_{DC}^2)$$

$W_{DC}$  storable energy in DC bus

$C_{DC}$  DC bus capacitance in device [F]

$C_{DCext}$  external DC bus capacitance [F]

$U_{R\_DC\_On}$  braking resistor switch-on threshold

$U_{DC}$  DC bus voltage

Fig. 16-19: Storable energy in DC bus

The additional capacitor has to be dimensioned in such a way that it can store the rotary drive energy:

$$C_{DCext} \geq \frac{2W_{rot}}{(U_{R\_DC\_On}^2 - U_{DC}^2)} - C_{DC}$$

$U_{R\_DC\_On}$  braking resistor switch-on threshold

$U_{DC}$  DC bus voltage

$W_{rot}$  rotary energy [Ws]

$C_{DC}$  internal capacitance [F]

$C_{DCext}$  required external DC bus capacitance [F]

Fig. 16-20: Required additional capacitance [F]



**CAUTION**

### Property damage caused by overload of HMV and HCS devices!

Comply with max. allowed external DC bus capacitances! See electrical data of the HMV and HCS components.

## Calculations



## CAUTION

**Property damage caused by overload of the additional external capacitors!**

- Only use allowed components.
- The properties of the additional capacitors have to comply with minimum requirements:
  - min. **dielectric strength**: DC 900 V
  - min. **current load capacity**:  $15 A_{\text{eff}} / \text{mF}$
  - min. **heat resistance**:  $105 \text{ }^\circ\text{C}$
  - max. **discharge time**: 30 min
  - Take measures against fire in the case of overload, e.g. by **housing** the capacitors.
- **Connect correct polarity**: Connect L+ to positive pole and L- to negative pole of the additional capacitors.



- For additional external capacitors, observe that the series connection of these units can require a balancing device.
- Dimension additional capacitors at the DC bus for 10% over-voltage at the mains connection.
- As the supply voltage increases the storable energy in the DC bus decreases, because the differential voltage between braking resistor switch-on threshold  $U_B$  and DC bus voltage  $U_{ZW}$  (crest value of supply voltage) is reduced.

The figure below illustrates the characteristic of the storable energy in the DC bus versus mains voltage with fixed braking resistor switch-on threshold  $U_B$  by the example of HCS02.1E devices.

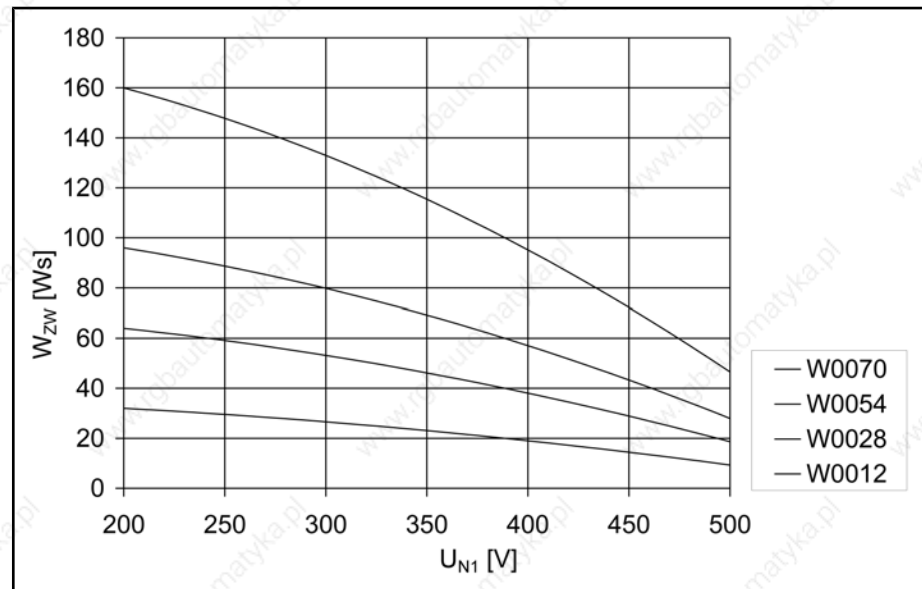

Fig. 16-21: Storable energy in DC bus

## 16.1.6 Continuous Regenerative Power



In terms of average period of time, the sum of the continuous regenerative power of all drives mustn't exceed the allowed continuous power of the regenerative device (regeneration of supply units or braking resistors of converters).

In applications with servo drives at typical NC machine tools, machining time is relatively long relative to the cycle time. Accordingly, the continuous regenerative powers are small. For this type of applications, exact calculation is not required. It is sufficient to make sure that the regenerative peak power is not exceeded.

Exact calculation is required, for example, for one of the following applications:

- applications with servo drives which are characterized by many acceleration and deceleration processes (e.g. nibbling machines or roll feeds)
- machine tools with modular main drive
- applications which involve lowering of large masses, e.g. loading bridges, warehousing and transport systems

Before the continuous regenerative power can be calculated, the rotary energy of the drives and the potential energy of non-balanced masses must be calculated.

$$W_{rot} = \frac{J_g}{2} \times \left( n_{eil} \times \frac{2\pi}{60} \right)^2 \times z$$

$W_{rot}$	rotary energy [Ws]
$n_{eil}$	speed at rapid traverse rate [min-1]
$J_g$	inertia (motor + load) [kgm <sup>2</sup> ]
$z$	number of braking processes per cycle

Fig. 16-22: Rotary energy of the drives

$$W_{pot} = m \times g \times h \times z$$

$W_{pot}$	potential energy [Ws]
$m$	load mass [kg]
$g$	gravitational acceleration = 9.81 m/s <sup>2</sup>
$h$	lowering height [m]
$z$	number of lowering processes per cycle

Fig. 16-23: Potential energy of non-balanced masses

$$P_{RD,Anlage} = \frac{W_{pot} + W_{rotg}}{t_z}$$

$$\sum P_{RD,Anlage} \leq \sum P_{BD,Geräte}$$

$P_{RD,Anlage}$	generated continuous regenerative power [kW]
$P_{BD,Geräte}$	allowed braking resistor continuous power [kW]
$t_z$	cycle time [s]
$W_{potg}$	sum of potential energies [kWs]
$W_{rotg}$	sum of rotary energies [kWs]

Fig. 16-24: Continuous regenerative power

Calculations



**Influence of efficiency**

The continuous regenerative power occurring in the steady-state condition in the majority of cases is less than the calculated energy absorption, because all involved components (such as load, gear, motor, cables) absorb a part of the regenerative energy.

Only reduce the generated continuous regenerative power when the efficiency behavior is known.

**Continuous Power of Braking Resistor**

Continuous power of the braking resistor:

$$P_{BD} = \frac{t_{on} \times P_{BS}}{T_{cycl}}$$

- $P_{BD}$  allowed continuous power of braking resistor
- $t_{on}$  allowed duty cycle
- $P_{BS}$  allowed peak power of braking resistor
- $T_{cycl}$  allowed cycle time

Fig. 16-25: Braking resistor continuous power



**Several braking resistors (e.g. HLR) at common DC bus**

With several braking resistors at the DC bus, the available continuous power is less than the sum of the individual continuous powers.

$$\sum P_{BD} = f \times (P_{BD\_1} + P_{BD\_2} + \dots + P_{BD\_n})$$

- $P_{BD\_1}, P_{BD\_2}, \dots, P_{BD\_n}$  data sheet data of the braking resistors
- $f$  balancing factor for PDB ( $f = 0.8$  (guide value); see also technical data of converter and supply unit)

Fig. 16-26: Sum of braking resistor continuous powers

**Relative Duty Cycle of Braking Resistor**

The quotient of  $t_{on}$  and  $T_{cycl}$  is understood by the duty cycle ED. The maximum allowed relative duty cycle  $ED_{max}$  is calculated from the nominal data for HLR braking resistors:

$$ED_{max} = \frac{t_{on}}{T_{cycl}}$$

- $ED_{max}$  maximum allowed relative duty cycle
- $t_{on}$  allowed duty cycle
- $T_{cycl}$  allowed cycle time

Fig. 16-27: Relative duty cycle of braking resistor



**Braking times**

Within the indicated minimum cycle time  $T_{cycl}$ , the braking resistor may be switched on, as a maximum, for the time  $t_{on}$ .



## 16.1.7 Peak Regenerative Power

Usually, peak regenerative power will occur when an E-Stop signal is triggered and all axes brake simultaneously.



**CAUTION**

### Risk of damage due to extended braking times and distances!

Select the supply unit such that the sum of peak regenerative powers of all drives does not exceed braking resistor peak power of the supply unit.

See the respective motor selection data for the peak regenerative powers.

Peak regenerative power can be roughly calculated by the following equation:

$$P_{ES} = \frac{M_{\max} \times n_{\max}}{9550 \times 1,25}$$

$$\sum P_{ES, \text{Anlage}} \leq \sum P_{ES, \text{Geräte}}$$

$P_{RS, \text{Anlage}}$	generated peak regenerated power [kW]
$P_{BS, \text{Geräte}}$	allowed braking resistor peak power [kW]
$M_{\max}$	maximum drive torque [Nm]
$n_{\max}$	maximum NC useful speed [min <sup>-1</sup> ]
1,25	constant for motor and controller efficiency

Fig. 16-28: Peak regenerative power

### Peak Power of Braking Resistor

The braking resistor makes available the peak power during its duty cycle. The peak power is calculated as follows:

$$P_{BS} = \frac{U_{R\_DC\_on}^2}{R_{DC\_bleeder}}$$

$P_{BS}$	effective peak power
$U_{R\_DC\_on}$	switch-on threshold
$R_{DC\_bleeder}$	

Fig. 16-29: Braking resistor peak power



### Several braking resistors (e.g. HLR) at common DC bus

With several braking resistors at the DC bus, the available peak power is determined as the sum of the individual peak powers. For this purpose, the same switch-on threshold must take effect for all involved braking resistors.



### Adjustment of switch-on threshold!

For the adjustment of the switch-on threshold, see also the following parameters:

- P-0-0833, Braking resistor threshold
- P-0-0858, Data of external braking resistor

## 16.1.8 Calculating the Control Factor

The control factor of an inverter is the ratio of its output voltage to a reference output voltage.

Calculations

The reference output voltage is the output voltage of the inverter at mains input voltage without overload.

$$a = \frac{U_{out}}{U_{out\_ref}} = \frac{U_{out}}{U_{LN}}$$

$U_{out}$  output voltage of inverter  
 $U_{out\_ref}$  reference output voltage  
 $U_{LN}$  mains voltage

Fig. 16-30: Control factor

If several inverters have effect on one supply unit at the same time, you have to consider the so-called mean control factor scaled with the axis power.

$$\bar{a} = \frac{1}{n \times P_{ZWD}} \times \sum_{i=1}^n (a_i \times P_{mi} \times 1,25)$$

$n$  number of inverters  
 $a_i$  several control factors  
 $P_{ZWD}$  DC bus continuous power [kW]  
 $P_{mi}$  mechanical continuous power [kW]

Fig. 16-31: Mean, scaled control factor

When the control factor falls below the required value (see data  $P_{DC\_cont}$  in the technical data of the corresponding supply unit), additional wattless power occurs. The additional wattless power can be compensated with additional capacitors in the DC bus. The required additional capacitance can be approximately calculated with the following formula.

$$C_{DC\_ext} = (a_0 - \bar{a}) \times P_{DC\_nenn} \times k_a$$

$C_{DC\_ext}$  required additional capacitance in DC bus in  $\mu F$   
 $a_0$  minimum required control factor  
 $a$  calculated mean control factor (e.g.  $a_0 > 0.8$ )  
 $P_{DC\_nenn}$  nominal power of supply unit [kW]  
 $k_a$  200 (preliminary); factor capacitance [ $\mu F$ ] / nominal power [kW]

Fig. 16-32: Required additional capacitances when control factor falls below minimum value

## 16.2 Calculations for the Mains Connection

### 16.2.1 Calculating the Mains-Side Phase Current

To select the appropriate mains contactor and the appropriate fusing of the power connection, the mains-side phase current  $I_N$  has to be calculated before.

The mains-side phase current  $I_N$  is determined from the mains connected load  $S_{LN}$ .

For the maximum mains connected load, see technical data of the drive controllers or calculate it according to the formula below and the formulas contained in the appendix. For several drive controllers, add the individual mains connected loads.

$$P_{DC} = \frac{M_{\text{eff}} \times n_m \times 2\pi}{60} \times k$$

$P_{DC}$  required DC bus continuous power in W  
 $M_{\text{eff}}$  effective torque in Nm  
 $n_m$  average speed in min-1  
 $k$  factor for motor and controller efficiency = 1.25  
**Fig. 16-33:** *Calculating the DC bus power*

$$S_{LN} = \frac{P_{DC}}{TPF}$$

$S_{LN}$  mains connected load in VA  
 $P_{DC}$  DC bus continuous power in W  
 $TPF$  Total Power Factor  $\lambda$   
**Fig. 16-34:** *Calculating the mains connected load*



For the data of **TPF** at nominal power and **TPF<sub>10</sub>** (at 10% of nominal power), see Project Planning Manual "Rexroth IndraDrive Supply Units and Power Sections" → Chapter of the respective device → "Technical Data" → "Basic Data" → table "Data for mains voltage supply".

Intermediate values can be interpolated with the diagram contained in this chapter.

$$I_{LN} = \frac{S_{LN}}{U_{LN}}$$

$I_{LN}$  mains-side phase current in A  
 $S_{LN}$  mains connected load in VA  
 $U_{LN}$  voltage between phases of mains in V  
**Fig. 16-35:** *Calculating the mains-side phase current (single-phase)*

$$I_{LN} = \frac{S_{LN}}{U_{LN} \sqrt{3}}$$

$I_{LN}$  mains-side phase current in A  
 $S_{LN}$  mains connected load in VA  
 $U_{LN}$  voltage between phases of mains in V  
**Fig. 16-36:** *Calculating the mains-side phase current (three-phase)*

## 16.2.2 Calculating the Inrush Current

For calculating the inrush current, take all devices connected to mains voltage into account. The resulting inrush current is the sum of the inrush currents of the individual devices.



For the data of the **inrush current  $I_{L\_trans\_max\_on}$** , see Project Planning Manual "Rexroth IndraDrive Supply Units and Power Sections" → Chapter of the respective device → "Technical Data" → "Basic Data" → table "Data for mains voltage supply".

Calculations

### 16.2.3 Mains Contactor and Fusing



For the data of **mains contactor**, **fusing** and the required **connection cross section** in operation under rated conditions, see Project Planning Manual "Rexroth IndraDrive Supply Units and Power Sections" → Chapter of the respective device → "Technical Data" → "Basic Data" → table "Data for mains voltage supply".

### 16.2.4 Calculations for the Mains Harmonics

#### Harmonic Load THD

The harmonic load of the mains is described by the THD (total harmonic distortion):

$$THD = \sqrt{\sum_{n=2}^{40} \left(\frac{I_n}{I_1}\right)^2}$$

- $I_n$  harmonic current of the n-th harmonic
- $I_1$  rms value of the 1st harmonic (fundamental wave)
- $I_2$  rms value of the 2nd harmonic
- $I_n$  rms value of the n-th harmonic

Fig. 16-37: THD (total harmonic distortion)

#### Harmonic Content / Distortion Factor k

The harmonic content of, for example, the mains current is described by the distortion factor k. The distortion factor contains all alternating components, both those of the fundamental wave ( $I_1$ ) and of the harmonics ( $I_k$ ). Direct components ( $I_0$ ) are not contained.

$$k_i = \frac{\sqrt{\sum_{k=2}^n I_k^2}}{\sqrt{\sum_{k=1}^n I_k^2}} = \sqrt{\frac{I_2^2 + I_3^2 + \dots}{I_1^2 + I_2^2 + I_3^2 \dots}}$$

- $k_i$  distortion factor or harmonic content
- $I_k$  harmonic current of the k-th harmonic
- $I_1$  rms value of the 1st harmonic (fundamental wave)
- $I_2$  rms value of the 2nd harmonic

Fig. 16-38: Distortion factor k or harmonic content

#### Power Factor $\cos\phi_1$ or DPF for Calculating the Wattless Power Load of the Mains

The power factor  $\cos\phi_1$  or DPF (distortion power factor) is used to calculate the wattless power load of the mains:

$$DPF = \cos\phi_1 = \frac{P_{netz}}{S_{1LN}}$$

- $P_{netz}$  effective mains power
- $S_{1LN}$  apparent mains power of fundamental wave

Fig. 16-39: Power factor  $\cos\phi_1$  / DPF

## Power Factor $\cos\varphi$ or TPF ( $\lambda$ )

The power factor  $\cos\varphi$  or TPF is used for rating mains components (transformer, fuse etc.):

$$TPF = \lambda = \cos\varphi = \frac{P_{\text{netz}}}{S_{\text{LN}}}$$

$P_{\text{netz}}$	effective mains power
$S_{\text{LN}}$	apparent mains power
Fig. 16-40:	Power factor $\cos\varphi$ / TPF / $\lambda$



Only for sinusoidal values does the power factor  $\cos\varphi$  equal the total power factor TPF ( $\lambda$ ).

## 16.2.5 Mains Voltage Unbalance

The voltage unbalance is described by a three-phase system consisting of the combination of the following systems:

- clockwise a.c. system (positive-sequence system  $U_m$ )
- counter-clockwise a.c. system (negative-sequence system  $U_g$ )
- d.c. system ( $U_0$ )

$$\frac{|U_x - U_{\text{AVE}}|}{U_{\text{AVE}}} \times 100\%$$

$U_x$	phase-to-phase voltage with highest deviation from average value
$U_{\text{AVE}}$	$= (U_{12} + U_{23} + U_{31}) / 3$ ; $U_{12}$ , $U_{23}$ , $U_{31}$ being voltages between the phases

Fig. 16-41: Definition of voltage unbalance

## 16.2.6 Calculating the Allowed Continuous Power in the Common DC Bus

By interconnecting the DC bus connections of several HCS02 and HLB01 drive controllers, the regenerative power and continuous power generated in the common DC bus are equally distributed to all IndraDrive C devices with braking resistor.

Distribution to the involved devices takes place with high balancing factor.

For Central Supply and Group Supply with DC Bus Connection

$$\sum P_{\text{BD, Geräte}} = \sum (P_{\text{BD, HCS}} + P_{\text{BD, HLB}}) \times f$$

$P_{\text{BD, Geräte}}$	braking resistor continuous power that all devices at common DC bus can process in continuous operation, in kW
$P_{\text{BD, HCS02}}$	braking resistor continuous power that the drive controller can process in continuous operation, in kW
$P_{\text{BD, HLB01}}$	braking resistor continuous power that the additional braking resistor module can process in continuous operation, in kW
$f$	balancing factor for parallel operation

Fig. 16-42: Available braking resistor continuous power at common DC bus

## Calculations

$$\sum P_{ZW, \text{Geräte}} = \sum P_{ZW} \times f$$

$P_{ZW, \text{Geräte}}$	available DC bus continuous power at common DC bus, in kW
$P_{ZW}$	DC bus continuous power of the individual devices, in kW
$f$	balancing factor for parallel operation
<i>Fig. 16-43:</i>	<i>Available DC bus continuous power at common DC bus</i>

## 16.3 Determining Components in the Mains Connection

### 16.3.1 Determining Mains Choke HNL

When using mains chokes, take their effect on the connected drive controllers into account. Due to their inductance, mains chokes have a smoothing effect on the current and thereby reduce harmonics.

To have the inductance available, comply with the nominal current of the mains choke.

Depending on the type of mains connection, we distinguish two cases.

**Case 1 (standard):** Only one drive controller or supply unit is connected to the mains choke (individual supply and central supply).

Selection criteria:

- Use of assigned mains choke according to Project Planning Manual of drive controller or supply unit.

**Case 2:** Several drive controllers or supply units are connected to the mains choke (group supply with and without DC bus connection).

Selection criteria:

- **Nominal current:**

$$I_N \geq \sum I_{LN}$$

$I_{LN}$	mains-side phase current in A
$I_N$	nominal current of mains choke in A
<i>Fig. 16-44:</i>	<i>Mains choke conditions</i>

- **Nominal inductance:** The nominal inductance of the individual mains choke has to be at least as high as the inductance of the greatest assigned mains choke of the connected drive controllers or supply units.

### 16.3.2 Determining Mains Filter HNF

#### Criteria for Selecting the Mains Filter

For selecting the appropriate mains filter, take the following criteria into account:

- EMC limit value class on site
- ambient conditions on site
- loading by harmonics on site
- loading by mains voltage and frequency on site
- loading by mains-side phase current
- total length of connected motor cables
- sum of leakage capacitances
- harmonics on mains voltage on site

#### How to Proceed for Selecting the Mains Filter

The selection of the mains filter is significantly determined by the operating conditions. How to proceed for selecting the mains filter:





When using HNF01, NFD03, HNS02 and HNK01 mains filters at **mains grounded via outer conductor**, install an isolating transformer between mains and mains filter.

1. Determine the required EMC limit value class for the application.
2. Determine the maximum applied mains voltage. Observe that not all Rexroth IndraDrive mains filters are suited for a mains voltage of 3 AC 500 V and, in the case of harmonics on mains voltage, check whether the mains voltage of the mains filter is loaded with harmonics and still allowed for the mains filter. For the allowed operating data depending on existing harmonics, see chapter [17.3 Emitted Harmonics on Mains Current and Mains Voltage](#), page 344.  
If necessary, make sure the harmonics are reduced on site.
3. Determine the kind of mains connection, such as central supply, group supply etc. (to do this, it is useful to outline the involved components and their interaction).
4. Calculate the **mains-side phase current** of the mains filter. For selecting the components, calculate the effective rms value. Chapter [16.2 Calculations for the Mains Connection](#), page 330 helps you with the calculation.  
Check or determine the maximum occurring ambient temperature. Select a mains filter with higher nominal current, when the ambient temperature is between 45 °C and 55 °C.
5. Select a mains contactor the nominal current of which does not exceed nominal current of mains filter.
6. Determine the number of drive axes. Take into account that HMD01 power sections are equipped with 2 axes.
7. Determine the total length of the connected motor cables.
8. Calculate the sum of the leakage capacitances on the load side of the mains filter. Determine the sum of the leakage capacitances from the number of operated axes and the length of the connected motor cables. Chapter [16.3.3 Determining the Leakage Capacitance](#), page 335 helps you with the calculation.
9. Select the appropriate mains connection (supply unit/converter, mains choke, mains filter) from the tables in chapter [8.3 Mains Connection Supply Units and Converters](#), page 85.

The **capacity of the mains filters** regarding the maximum allowed number of drive controllers and the maximum allowed total motor cable length depends on whether you use an HMV supply unit or supply other drive controllers with HCS drive controllers. For supply by an HMV supply unit, the allowed number and allowed total length are higher.

### 16.3.3 Determining the Leakage Capacitance

The capacitances which generate so-called leakage currents against ground at the outputs of inverters are regarded as leakage capacitance  $C_{ab}$ . The decisive values for the total value  $C_{ab,g}$  of the leakage capacitance are:

- capacitances of output filters
- capacitances of motor cables (capacitance per unit length against shield and ground wire)
- capacitances of motors (winding capacitance against housing)



Calculations



The capacitance per unit length of the hybrid cable of Rexroth IndraDrive Mi is insignificant for determining the leakage capacitance, because the hybrid cable is at the DC bus and not at the output of the inverter.

The leakage capacitance consists of the values of motor cable and motor of all individual drives operated at the mains filter.

Calculation:

$$C_{ab\_g} = C_{ab\_Mg} + C_{ab\_Kg}$$

- $C_{ab\_g}$  total value of leakage capacitance
- $C_{ab\_Mg}$  total value of leakage capacitance of motor
- $C_{ab\_Kg}$  total value of leakage capacitance of cable

Fig. 16-45: Total leakage capacitance

The total capacitance  $C_{ab\_Mg}$  results from the sum of capacitances of the individual motors. For these individual capacitances, see documentation of the motor. For a list of selected values, see Appendix of this documentation under "Capacitances Against Ground".

$$C_{ab\_Mg} = C_{ab(Motor\_1)} + C_{ab(Motor\_2)} \dots + C_{ab(Motor\_n)}$$

- $C_{ab(motor)}$  leakage capacitance of a motor
- Fig. 16-46: Total leakage capacitance of motor

$$C_{ab\_Kg} = C_{Y\_K\ typ(K1)} \times I_{(K1)} + C_{Y\_K\ typ(K2)} \times I_{(K2)} \dots + C_{Y\_K\ typ(Kn)} \times I_{(Kn)}$$

- $C_{Y\_K\ typ}$  capacitance per unit length of cables
  - $C_{ab\_Kg}$  total leakage capacitance of cables
- Fig. 16-47: Total leakage capacitance of cables

The total capacitance  $C_{ab\_Kg}$  consists of the sum of capacitances of the individual motor cables. For the individual capacitances per unit length, see the technical data of the motor cables. For a list of selected values, see Appendix of this documentation under "Capacitances Against Ground".

### 16.3.4 Determining the Allowed Operating Data of Mains Filters

#### Reducing Allowed Operating Voltage Depending on Actual Temperature Rise Due to Harmonics

The mains filters may only be operated in the allowed mains voltage range. Harmonics ( $f_n$ ) at the system voltage cause additional temperature rise of the dielectric of the capacitors used in the filter. Calculating the temperature rise:

$$\Delta T_n = \frac{10 \times (U_{Mn})^2}{(U_{Gn})^2} [K]$$

- $U_{Mn}$  measured voltage value at frequency  $f_n$  (harmonic)
- $U_{Gn}$  voltage limit value for frequency  $f_n$
- $\Delta T_n$  calculated temperature rise of the dielectric for frequency  $f_n$

Fig. 16-48: Calculating the temperature rise of the dielectric

The temperature rises have to be added up for all frequencies  $f_n \geq f_k$  ( $f_k$ : frequency at which the voltage derating of the filter starts):

$$\Delta T_{\text{ges}} = \sum_{v=1}^{\infty} \Delta T_v = \sum_{v=1}^{\infty} \frac{10 \times (U_{Mv})^2}{(U_{Gv})^2} [K] \leq 10 [K]$$

$U_{Mv}$  voltage value at frequency  $f_v$

$U_{Gv}$  voltage limit value for frequency  $f_v$

$\Delta T_{\text{ges}}$  calculated temperature rise of the dielectric for all frequencies

Fig. 16-49: Calculating the temperature rise of the dielectric for all frequencies

With the above formulas and the measured voltages, it is possible to determine the real load of a filter with voltages of higher frequencies. To this end, the rms value of the voltage on the mains side of the filter with all occurring frequencies (higher than  $f_k$ ) must be measured by means of a Fourier analysis for all combinations of line/line and line/PE. You always have to measure the voltages under conditions of operation at the nominal working point, the filter having been installed. By means of the measured values, it is then possible to calculate the temperature rise. To do this, the limit values of the following diagram are read at the respective frequency and used in the formula together with the measured value.

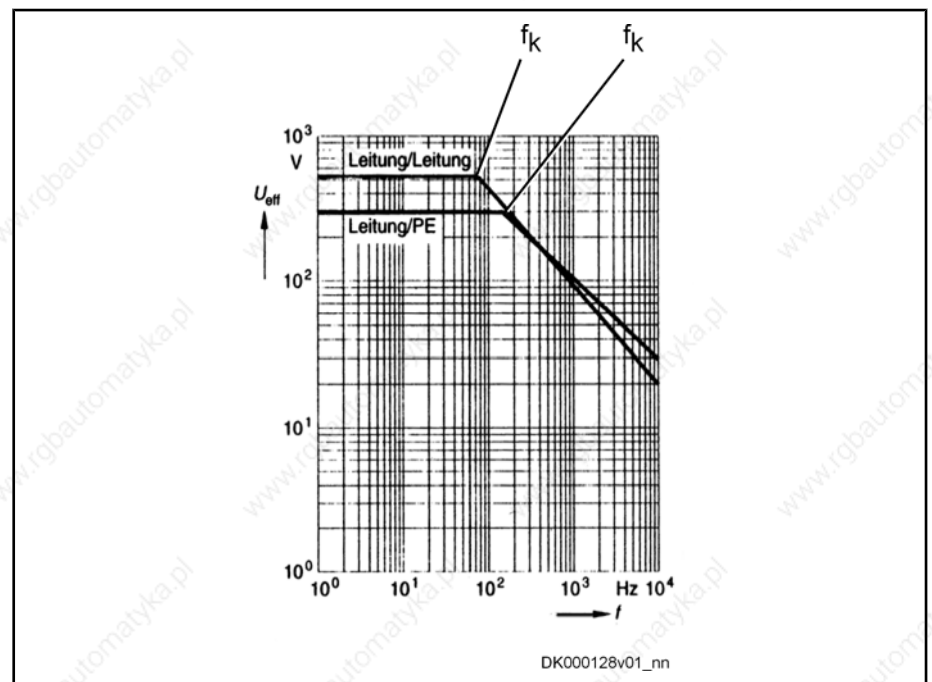

Fig. 16-50: Derating

If the total of the temperature values is greater than 10 K, the harmonics have to be reduced by means of appropriate measures.

### Current Reduction in the Case of Overtemperature

The mains filters recommended by Rexroth have been dimensioned for an ambient temperature of 45 °C.

For higher temperatures, reduce the mains current according to the following formula:

Calculations

$$I = I_{Netz} \times \sqrt{\frac{85 - T_{amb}}{40}}$$

$I_{Netz}$  nominal current of filter at 45 °C  
 $T_{amb}$  ambient temperature on site  
 Fig.16-51: Current reduction in the case of overtemperature

## 16.4 Other Calculations

### 16.4.1 Charging the DC Bus

To estimate the delay time  $t_d$  which a supply unit or a converter needs to charge the DC bus, consider the following interrelation:

- Delay time  $t_d$  from connection of mains voltage to the device (from status "ready for operation") and the status "drive ready". See also parameter "P-0-0115, Device control: status word " or "S-0-0135, Drive status word"

Delay Time  $t_d$

$$t_d = R_{lade} \times 1,2 \times C_{DC} \times 3 + 200ms$$

$t_d$  delay time  
 $R_{lade}$  effective charging resistance  
 $C_{DC}$  effective DC bus capacitance  
 Fig.16-52: Delay time for three-phase operation

The interrelation applies to three-phase mains connection. For single-phase mains operation assume the double time or control following processes via the status "P-0-0115, Device control: status word".

#### Effective Charging Resistance with Several Mains Supplies

Effective charging resistance of all drive controllers at common DC bus connected to mains voltage:

$$\frac{1}{R_{lade}} = \frac{1}{R_{lade\_1}} + \frac{1}{R_{lade\_2}} + \dots + \frac{1}{R_{lade\_n}}$$

Fig.16-53: Several charging resistances

#### Effective Charging Resistance with One Mains Supply

Effective charging resistance of one drive controller at common DC bus connected to mains voltage:

$$R_{lade} = \frac{U_{LN}}{I_{L\_trans\_max\_on}}$$

$U_{LN}$  mains voltage  
 $I_{L\_trans\_max\_on}$  inrush current  
 Fig.16-54: Charging resistance



For the data of the inrush current  $I_{L\_trans\_max\_on}$  and the mains voltage  $U_{LN}$ , see Project Planning Manual "Rexroth IndraDrive Supply Units and Power Sections" → Chapter of the respective device → "Technical Data" → "Basic Data" → table "Data for mains voltage supply".

#### Resulting DC Bus Capacitance

Effective DC bus capacitance of all devices at common DC bus:

$$C_{DC} = C_{DC1} + C_{DC2} \dots + C_{DCn} + C_{DCent}$$

$C_{DC}$  capacitance in DC bus

Fig. 16-55: DC bus capacitance



For the data of the **capacitance in DC bus  $C_{DC}$** , see Project Planning Manual "Rexroth IndraDrive Supply Units and Power Sections" → Chapter of the respective device → "Technical Data" → "Basic Data" → table "Data of power section - DC bus".



# 17 Appendix

## 17.1 System Elements - Product Overview, Short Designations

Short designation	System element / product	Description
BAM	motor holding brake	
CSB01.1	control section single-axis	scope of functions BASIC
CDB01.1	control section double-axis	
CSH01.1, CSH01.2	control section single-axis	scope of functions ADVANCED
CZ 1.2	additional capacitor	capacitor with touch guard
DLT	isolating transformer	
DST	matching transformer	
HAT01.1		control unit for motor holding brake (e.g. BAM)
HAB01	blower unit	blower to be mounted to certain HMV01 and HMS01
HAC01	hosing for control sections	
HAS01	basic accessories	accessories for connecting the components (contact bars, fixing material ...)
HAS02	shield connection	accessory for connecting shielded motor cables to power sections
HAS03	control cabinet adapter	accessory for adjusting the mounting depth
HAS04	capacitor	accessory DC bus capacitors against ground potential
HAS05	cables, connectors, adapters	accessories to adjust electrical interfaces
HCS02.1	drive controller	converter
HCS03.1	drive controller	converter
HLB01.1C	DC bus resistor unit	for IndraDrive C
HLB01.1D	DC bus resistor unit	for IndraDrive M
HLC01.1C	DC bus capacitor unit	for IndraDrive C
HLC01.1D	DC bus capacitor unit	for IndraDrive M
HLR01	braking resistor	
HMD01.1	drive controller	power section, double-axis
HMF01.1	motor filter	
HMS01.1	drive controller	power section, single-axis
HMS02.1	drive controller	power section, single-axis
HMV01.1E	supply unit	supply unit, infeeding
HMV01.1R	supply unit	supply unit, infeeding and regenerative
HMV02.1R	supply unit	supply unit, infeeding and regenerative
HNF01.1	mains filter	

## Appendix

Short designation	System element / product	Description
HNL01.1	mains choke	designs for infeeding systems (E) regenerative systems (R) in current-compensated design
HNL02.1	mains choke	mains choke with housing for control cabinet mounting
HNS02.1	mains filter	mains filter with integrated switch-disconnector and motor circuit breaker
HNK01.1	mains filter	mains filter with integrated mains choke, variant for mounting
KCU01	electronic control system	additional component of IndraDrive Mi product range, to connect KSM to HMV supply units or HCS converters
KSM	distributed servo motor	distributed servo motor of IndraDrive Mi product range
MPB	firmware	scope of functions BASIC
MPD	firmware	scope of functions BASIC, double-axis
MPH	firmware	scope of functions ADVANCED
MSK	synchronous motor	
NFD03.1	mains filter	
RKL	ready-made cable	ready-made motor power cable
RKS	ready-made cable	ready-made control cable
RKG	ready-made cable	ready-made encoder cable
RKH	ready-made cable	system cable of IndraDrive Mi product range
VCP01	comfort control panel	variant to be plugged on
VCP02	operator terminal	variant for assembly
VCP05	operator terminal	variant for assembly
VCP08	operator terminal	variant for assembly
VCP20	operator terminal	variant for assembly
VCP25	operator terminal	variant for assembly

Fig.17-1: Product short designations

## 17.2 Capacitances Against Ground

### 17.2.1 General Information

The given capacitance values are used to select appropriate mains filters of the HNF01 and NFD03 lines.

### 17.2.2 Capacitance Data for Motors

Rexroth motors have the typical capacitance values listed below. The data refer to the total capacitance of the power connections U, V, W against the motor housing.

Motor types	Length	Symbol	Unit	Typ. value
MKD025	A	$C_{ab}$	nF	
MKE037	B	$C_{ab}$	nF	1,0



Motor types	Length	Symbol	Unit	Typ. value
MKD	A	C <sub>ab</sub>	nF	
MHD				
MHP041	B	C <sub>ab</sub>	nF	1,6
MKE047				
MKD	A	C <sub>ab</sub>	nF	1,2
MHD				
MHP071	B	C <sub>ab</sub>	nF	2,5
MKD				
MHD	B	C <sub>ab</sub>	nF	6,7
MHP090				
MKE098				
MHD	A	C <sub>ab</sub>	nF	4,8
MHP093	B	C <sub>ab</sub>	nF	7,8
	C	C <sub>ab</sub>	nF	9,5
MHD	A	C <sub>ab</sub>	nF	3,7
MHP095	B	C <sub>ab</sub>	nF	5,3
	C	C <sub>ab</sub>	nF	6,7
MKD	A	C <sub>ab</sub>	nF	5,3
MHD	B	C <sub>ab</sub>	nF	10,3
MHP112	C	C <sub>ab</sub>	nF	14,1
MKE118	D	C <sub>ab</sub>	nF	20,2
MKD	A	C <sub>ab</sub>	nF	6,9
MHD	B	C <sub>ab</sub>	nF	13,2
MHP115	C	C <sub>ab</sub>	nF	18,2
MHD131	B	C <sub>ab</sub>	nF	13,9
	D	C <sub>ab</sub>	nF	25,7
MSK050	B	C <sub>ab</sub>	nF	2,1
	C	C <sub>ab</sub>	nF	2,6
MSK060	B	C <sub>ab</sub>	nF	2,1
	C	C <sub>ab</sub>	nF	
MSK070	C	C <sub>ab</sub>	nF	3,1
	D	C <sub>ab</sub>	nF	
	E	C <sub>ab</sub>	nF	
	<b>Size, length, winding</b>			<b>preliminary</b>

## Appendix

Motor types	Length	Symbol	Unit	Typ. value
KSM01.2B-	041C-42	$C_{ab}$	nF	11,3
	061C-35	$C_{ab}$	nF	2,4
	061C-61	$C_{ab}$	nF	2,2
	071C-24	$C_{ab}$	nF	5,0
	071C-35	$C_{ab}$	nF	4,7
	076C-35	$C_{ab}$	nF	6,9

Fig. 17-2: Leakage capacitance of selected motors

The scope of available motors is continuously extended. Please ask for data of motors not contained in this list.

## 17.2.3 Capacitance Data for Power Cables

The motor cables of Rexroth's "RKL" line have the capacitances per unit length listed below. The values refer to the sum of the single capacitances of power strands 1, 2 and 3 against the overall shield. For motor cables of the "RKH" line (hybrid cable of IndraDrive Mi), the value refers to the power strands L+, L- against the overall shield.

Type of non-assembled cable	Nominal cross section [mm <sup>2</sup> ]	Symbol	Unit	Value
INK 653	1,0	$C_{Y,K \text{ typ}}$	nF/m	0,6
INK 650	1,5	$C_{Y,K \text{ typ}}$	nF/m	0,8
INK 602	2,5	$C_{Y,K \text{ typ}}$	nF/m	0,7
INK 603	4	$C_{Y,K \text{ typ}}$	nF/m	tbd
INK 604	6	$C_{Y,K \text{ typ}}$	nF/m	0,8
INK 605	10	$C_{Y,K \text{ typ}}$	nF/m	1,0
INK 606	16	$C_{Y,K \text{ typ}}$	nF/m	1,2
INK 607	25	$C_{Y,K \text{ typ}}$	nF/m	1,1
INK 667	35	$C_{Y,K \text{ typ}}$	nF/m	tbd
INK 668	50	$C_{Y,K \text{ typ}}$	nF/m	tbd
REH0800	n.s.	$C_{Y,K \text{ typ}}$	nF/m	0,2

Fig. 17-3: Capacitance values of power cables (non-assembled cables)



Approximate calculation is allowed with the following values:

- 1 nF/m for cross sections from 1 mm<sup>2</sup> to 6 mm<sup>2</sup>
- 1.2 nF/m for cross sections from 10 mm<sup>2</sup> to 50 mm<sup>2</sup>

## 17.3 Emitted Harmonics on Mains Current and Mains Voltage

### 17.3.1 General Information

Due to their electric design, the drive controllers and supply units generate harmonics in the mains current and on the mains voltage during operation at the

mains. Using appropriate mains chokes decisively influences power factors and mains harmonics.



For comments on the short designations used, see chapter 16.2 Calculations for the Mains Connection, page 330.

## 17.3.2 Harmonics of Mains Current

Harmonics of Supply Units, Infeeding (HMV...E and HCS)



The harmonics of the mains current are decisively reduced by the use of mains chokes.



For mains with mains frequency  $f_{LN} = 60$  Hz, the values accordingly are multiples of  $f_{LN} = 60$  Hz.

Formulas see chapter "Calculations".

	$I_{Lcont}$	Without mains choke			With HNL Mains choke			With mains choke of higher inductance 1.7 x $L_N$ of HNL		
		5%	50%	100%	5%	50%	100%	5%	50%	100%
k	f	Ik/I1	Ik/I1	Ik/I1	Ik/I1	Ik/I1	Ik/I1	Ik/I1	Ik/I1	Ik/I1
	Hz	%	%	%	%	%	%	%	%	%
1	50	100%	100%	100%	100%	100%	100%	100%	100%	100%
2	100	3	2	1	2	1	0,2	2	1	0,5
3	150	9	3	2	8	2	1	7	2	1
4	200	1	2	1	1	1	0,2	1	1	0,5
5	250	95	90	85	84	70	61	71	55	38
6	300	3	2	1	2	2	0,5	2	1	0,5
7	350	85	80	75	71	40	36	58	28	13
8	400	3	3	1	1	2	0,5	1	2	0,5
9	450	2	2	1	6	1	1	5	1	0,5
10	500	1	1	1	1	1	0,5	1	1	0,5
11	550	70	60	50	40	6	4,2	27	7	6,5
12	600	1	1	1	1	1	0,5	1	1	1
13	650	46	55	45	28	5	5,1	17	5	3
14	700	2	2	1	1	1	1	2	1	1
15	750	2	1	1	1	1	1	2	1	1
16	800	1	1	1	1	1	0,5	2	1	1
17	850	30	25	20	1	0,5	0,5	6	3	2,5
18	900	1	1	1	1	0,5	0,5	1	1	1
19	950	20	13	10	1	0,5	0,5	7	1	2
20	1000	2	2	1	0,5	0,5	0,5	2	1	1
21	1050	2	1	1	0,5	0,5	0,5	1	1	1



		Without mains choke			With HNL Mains choke			With mains choke of higher inductance 1.7 x L <sub>N</sub> of HNL		
		5%	50%	100%	5%	50%	100%	5%	50%	100%
k	I <sub>L_cont</sub>	Ik/I1	Ik/I1	Ik/I1	Ik/I1	Ik/I1	Ik/I1	Ik/I1	Ik/I1	Ik/I1
	f	%	%	%	%	%	%	%	%	%
THD	%	173,08	156,32	144,86	120,86	81,18	71,24	98,08	62,61	41,12
ki		0,87	0,84	0,82	0,77	0,63	0,58	0,70	0,53	0,38

k	k = 1: fundamental wave; k ≥ 2: harmonics number
I <sub>L_cont</sub>	maximum input current (mains input continuous current), see technical data of device - Data for mains voltage supply
ki	distortion factor or harmonic content
I <sub>k</sub>	harmonic current of the k-th harmonic
I <sub>1</sub>	rms value of the 1st harmonic (fundamental wave)
THD	Total Harmonic Distortion
Fig. 17-4:	Harmonics HMV...E and HCS

### Harmonics of Supply Units, Regenerative (HMV...R)



In the end application, the harmonics values are within the minimum and maximum values listed below. The harmonics values depend on

- load distribution
- conditions in the mains
- mains pollution which other devices feed in the mains

If the degree of mains pollution generated by other devices is low, the resulting values of the harmonics in the mains current of the drive system are minimum values. If there is a high degree of mains pollution generated by other devices, the maximum values of the table can be reached in the worst case.

k	f	Ik/I1		
		Min.	Typ.	Max.
	Hz	%	%	%
1	50	100%	100%	100%
2	100	2,5	4	25
3	150	2	5	25
4	200	2	3	25
5	250	2	17	35
6	300	2	2	30
7	350	1,6	7	30
8	400	1	2	12
9	450	1	2	10
10	500	1	2	8
11	550	1	5	12
12	600	1	2	7
13	650	1	2	6

## Appendix

k	f	Ik/I1		
		Min.	Typ.	Max.
	Hz	%	%	%
14	700	1	2	3
15	750	1	2	3
16	800	0,5	2	3
17	850	0,5	2	3
18	900	0,5	2	3
19	950	0,5	2	3
20	1000	0,5	2	2
21	1050	0,5	1	2
22	1100	0,5	1	2
23	1150	0,5	1	2
24	1200	0,5	1	2
25	1250	0,5	1	2
26	1300	0,5	1	1
27	1350	0,5	1	1
28	1400	0,5	1	1
29	1450	0,5	1	1
30	1500	0,5	0,5	1
31	1550	0,5	0,5	1
32	1600	0,5	0,5	1
33	1650	0,5	0,5	0,5
34	1700	0,5	0,5	0,5
35	1750	0,5	0,5	0,5
36	1800	0,5	0,5	0,5
37	1850	0,5	0,5	0,5
38	1900	0,5	0,5	0,5
39	1950	0,5	0,5	0,5
40	2000	0,5	0,5	0,5
41	2050	0,5	0,5	0,5
42	2100	0,5	0,5	0,5
43	2150	0,5	0,5	0,5
44	2200	0,5	0,5	0,5
45	2250	0,5	0,5	0,5
46	2300	0,5	0,5	0,5
47	2350	0,5	0,5	0,5
48	2400	0,5	0,5	0,5

		Ik/I1		
k	f	Min.	Typ.	Max.
	Hz	%	%	%
49	2450	0,5	0,5	0,5
50	2500	0,5	0,5	0,5
THD	%	6,45	21,89	74,34
ki		0,06	0,21	0,60

Min. values in the case of a low degree of mains pollution by other devices  
 Typ. values in the case of standard applications in industrial mains  
 Max. values in the case of a high degree of mains pollution by other devices  
 k k = 1: fundamental wave; k ≥ 2: harmonics number  
 I<sub>L,cont</sub> maximum input current (mains input continuous current), see technical data of device - Data for mains voltage supply  
 ki distortion factor or harmonic content  
 I<sub>k</sub> harmonic current of the k-th harmonic  
 I<sub>1</sub> rms value of the 1st harmonic (fundamental wave)  
 THD Total Harmonic Distortion  
 Fig.17-5: Harmonics HMV01.1R

### 17.3.3 Harmonics on Mains Voltage

The voltage harmonics depend on the structure of the mains, especially on the mains inductance or the mains short-circuit power at the connection point. At different mains and mains connection points, one device can cause different voltage harmonics.

For a normal mains, the harmonics content of the mains voltage when operating drives generally is below 10%. Short-time drops in mains voltage are below 20%.

More precise values can only be calculated with exact knowledge of the mains data (mains topology), such as line inductance and line capacitance related to the connection point.

These values, however, can temporally vary quite strongly, according to the switch status of the mains. The harmonics of the mains voltage thereby change, too.

Rough estimated values of the mains data are not sufficient for pre-calculation of the harmonics, as mainly the resonance points always present in the mains have a strong influence on the harmonics content.

In order to keep the degree of mains voltage harmonics as low as possible, you should, if possible, not connect capacitors or compensation units (capacitor batteries) directly to the mains. If capacitors or compensation units are absolutely required, you should only connect them to the mains via chokes.

## 17.4 Voltage Pulse for Test According to EN61000

The figure below shows the voltage pulse for defining the impulse withstand voltage according to EN61000.



Appendix

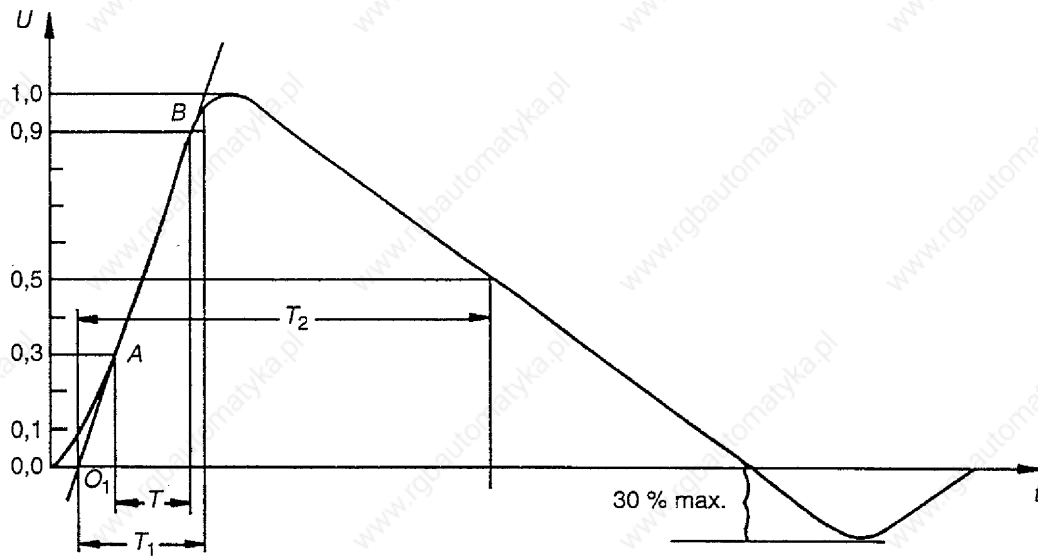

front time:  $T_1 = 1.67 \cdot T = 1.2 \mu\text{s} \pm 30 \%$

halftime:  $T_2 = 50 \mu\text{s} \pm 20 \%$

**Pulse shape of voltage at no load (1.2/50  $\mu\text{s}$ )  
(Definition of pulse shape acc. to IEC 60-1)**

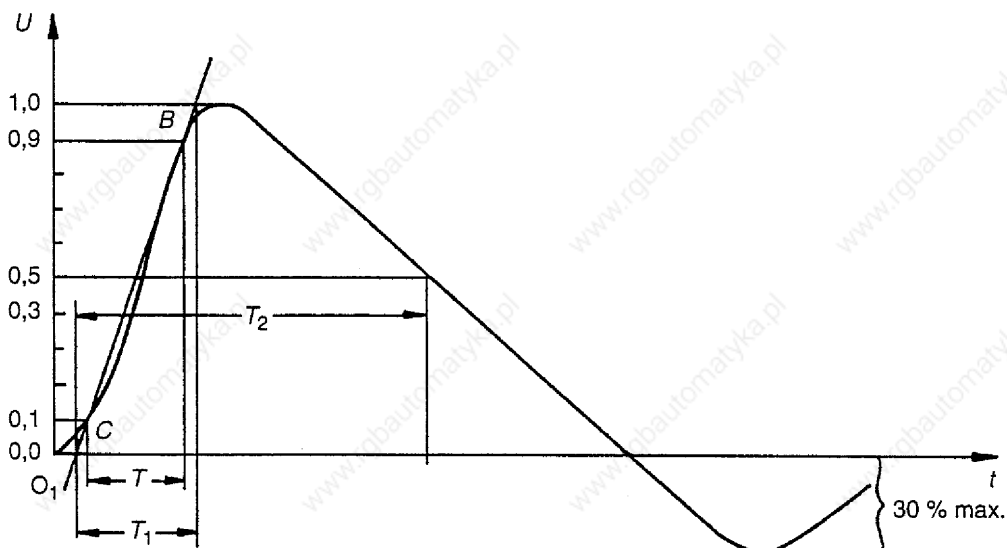

front time:  $T_1 = 1.25 \cdot T = 8 \mu\text{s} \pm 20 \%$

halftime:  $T_2 = 20 \mu\text{s} \pm 20 \%$

**Pulse shape of voltage at no load (8/20  $\mu\text{s}$ )  
(Definition of pulse shape acc. to IEC 60-1)**

Fig. 17-6: Impulse withstand voltage 1,2/50  $\mu\text{s}$  and 8/20  $\mu\text{s}$  according to EN 61000

## 17.5 Discharging of Capacitors

### 17.5.1 Discharging of DC Bus Capacitors

In the drive system Rexroth IndraDrive, capacitors are used in the DC bus as energy stores. In the drive controllers and particularly in the supply units, such capacitors have already been integrated.

Energy stores maintain their energy even when energy supply has been cut off and have to be discharged before somebody gets in contact with them.

Discharging devices have been integrated in the components of the drive system Rexroth IndraDrive; within the indicated discharging time, these devices discharge the voltage below the allowed 50 V.

If additional capacitances in the form of

- DC bus capacitor units or
- additional capacitors

are connected, make sure that these capacitors, too, are discharged before somebody gets in contact with them.

Due to the operating principle, the discharging time is the longer

- the bigger the energy store (the capacitance value)
- the higher the voltage to which the energy store has been charged
- the greater the resistance for discharging the capacitors.

Components of the drive system Rexroth IndraDrive have been dimensioned in such a way that after the energy supply was cut off the voltage value falls below 50 V within a discharging time of a maximum of 30 minutes.



**WARNING**

#### Lethal electric shock caused by live parts with more than 50 V!

- Wait at least 30 minutes after switching off power to allow discharging.
- Check whether voltage has fallen below 50 V before touching live parts!

To shorten the waiting time until voltage has fallen below 50 V, you can take the following measures:

- Activate the function "ZKS" when using HMV01 supply units.



**WARNING**

#### Lethal electric shock caused by live parts with more than 50 V!

Check whether voltage has fallen below 50 V before touching live parts!

- Use the discharging device described below.

### 17.5.2 Discharging Device



**WARNING**

#### Lethal electric shock caused by live parts with more than 50 V!

Before touching live parts, check in any case whether the voltage between the DC bus terminals L+ and L- has fallen below 50 V!

#### Operating Principle

A contactor is installed to switch a resistor to the terminals L+ and L- of the DC bus connection to discharge the capacitors. The contactor is activated via a control input which is supplied with appropriate control voltage.

Appendix

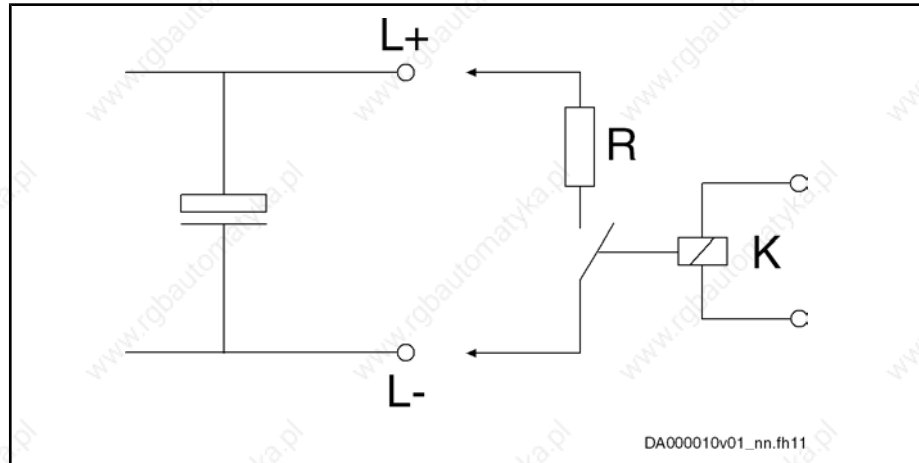

R: discharging resistor  
 K: contactor contact

Fig. 17-7: Operating principle of discharging device

**Dimensioning** The individual components have to be sufficiently dimensioned:

- The value of the discharging resistor has to be dimensioned with 1000 ohm and at least 1000 W.
- The discharging resistor and the contactor contact have to withstand the loads of practical operation (for example in the case of frequent use of the discharging device of the occurring continuous power).
- The contactor contact has to withstand the occurring direct voltage of min. 1000 V.
- The contactor contact has to withstand the occurring discharge current according to the resistance value that is used, i.e. 1 A with 1000 ohm.

**How to Proceed for Discharging** Observe the proceeding when using the discharging device:

1. Install discharging device before switching energy supply on for the first time and establish safe electrical connection between discharging device and object to be discharged.
2. On mains side, switch off energy supply to drive system before activating discharging device.
3. Activate discharging device.

## 18 Disposal and Environmental Protection

### 18.1 Disposal

#### 18.1.1 Products

Our products can be returned to us free of charge for disposal. However, it is a precondition that the products are free of oil, grease or other dirt.

Furthermore, the products returned for disposal must not contain any undue foreign matter or foreign component.

Please send the products free domicile to the following address:

Bosch Rexroth AG

Electric Drives and Controls

Bürgermeister-Dr.-Nebel-Strasse 2

D-97816 Lohr am Main

#### 18.1.2 Packaging Materials

The packaging materials consist of cardboard, wood and polystyrene. These materials can be easily recycled in any municipal recycling system. For ecological reasons, please refrain from returning the empty packages to us.

### 18.2 Environmental Protection

#### 18.2.1 No Release of Hazardous Substances

Our products do not contain any hazardous substances which may be released in the case of appropriate use. Accordingly, our products will normally not have any negative effect on the environment.

#### 18.2.2 Materials Contained in the Products

##### Electronic Devices

Electronic devices mainly contain:

- steel
- aluminum
- copper
- synthetic materials
- electronic components and modules

##### Motors

Motors mainly contain:

- steel
- aluminum
- copper
- brass
- magnetic materials
- electronic components and modules

## Disposal and Environmental Protection

### 18.2.3 Recycling

Due to their high content of metal, most of the product components can be recycled. In order to recycle the metal in the best possible way, the products must be disassembled into individual modules.

Metals contained in electric and electronic modules can also be recycled by means of special separation processes. The synthetic materials remaining after these processes can be thermally recycled.

If the products contain batteries or rechargeable batteries, these batteries are to be removed before recycling and disposed of.

## 19 Service and Support

### 19.1 Helpdesk

Our service helpdesk at our headquarters in Lohr, Germany, will assist you with all kinds of inquiries.

Contact us:

- By phone through the Service Call Entry Center,  
Monday to Friday 7:00 am - 6:00 pm CET  
**+49 (0) 9352 40 50 60**
- By fax  
**+49 (0) 9352 40 49 41**
- By e-mail: [service.svc@boschrexroth.de](mailto:service.svc@boschrexroth.de)

### 19.2 Service Hotline

Out of helpdesk hours please contact our German service department directly:

**+49 (0) 171 333 88 26**

or

**+49 (0) 172 660 04 06**

Hotline numbers for other countries can be found in the addresses of each region (see below).

### 19.3 Internet

Additional notes regarding service, maintenance and training, as well as the current addresses of our sales and service offices can be found on

<http://www.boschrexroth.com>

Outwith Germany please contact our sales/service office in your area first.

### 19.4 Helpful Information

For quick and efficient help please have the following information ready:

- Detailed description of the fault and the circumstances
- Information on the type plate of the affected products, especially type codes and serial numbers
- Your phone and fax numbers as well as your e-mail address so we can contact you in case of questions





# Index

## Symbols

- 24V control voltage supply 43
- 24V supply 40
  - Continuous power 44
  - Determining the data for selection 43
  - Installation 45
  - Internal 41
  - Peak current 45

## A

- Abbreviations 341
- Accessories
  - In the drive system Rexroth IndraDrive 201
- Accessories HAS
  - Brief description 32
- Accessories HAS01 201
- Accessories HAS05 268
- Accessory
  - Connection of two cables, adapter 302
  - D-Sub to terminal connector, adapter 295
  - HAS05.1-001 270
  - HAS05.1-002 272
  - HAS05.1-003 273
  - HAS05.1-005 285
  - HAS05.1-006 290
  - HAS05.1-007 295
  - HAS05.1-008 302
  - Motor holding brake control, adapter 290
- Adapter
  - Mains and motor connection 270
- Additional components
  - Arrangement 158
  - For supply units and converters 97
- Additional external capacitors
  - Calculations 324
- Ambient conditions 36
- ANAX 105
- Applications
  - Drive system Rexroth IndraDrive 27
- Appropriate use 15
  - Applications 15
- Arrangement
  - Performance-dependent 158

## B

- Bar, 228
  - Use 202
- Bb contact 111
  - Properties 112
- Bb Contact
  - Load capability limits 112
- Blower unit HAB01
  - Brief description 31
- Bonding conductor 200

## Boring dimensions

- For the mounting plate 150

## Braking resistor

- Continuous power 328
- Duty cycle 328
- Duty cycle, relative 328
- Energy absorption 324
- Peak power 329

## Braking resistor HLR01

- Brief description 30

## Braking resistors HLR

- For HCS02 100
- For HCS03 101

## Branch

- Fusing 66

## Bus cable

- Extension 309

## Bus master 288

## C

### Cable

- INK0572 290
- RKB0010 289

### Cables

- Capacitance 344
- Connection cables to motor 106

### Calculations 319

- Additional external capacitors 324
- Charging the DC bus 338
- Continuous power in the common DC bus 333
- Continuous regenerative power 326
- Control factor 329
- DC bus continuous power 319
- DC bus peak power 322
- Distortion factor 332
- DPF 332
- Harmonic content 332
- Inrush current 331
- Leakage capacitance 335
- Mains choke HNL 334
- Mains connection 330
- Mains filters: allowed operating data 336
- Mains harmonics 332
- Peak regenerative power 329
- Phase current 330
- Power dissipation 324
- Power factor  $\cos\phi$  333
- Power factor  $\cos\phi_1$  332
- Regenerative power 323
- TPF ( $\lambda$ ) 333
- Wattless power load 332

### Capacitance

- Motors 342
- Power cables 344

### Capacitance per unit length 108

## Index

- Capacitors
  - Discharging 351
- Capacity utilization 38
- CCC, China Compulsory Certification 34
- CDB01
  - Brief description 29
- CE label 33
- Central supply
  - HCS 77
  - HMV 73
- Certifications 33
- Charging the DC bus
  - Calculations 338
- Circulation 149
- Combination
  - Firmware, control section, power section 102
  - With components of the control range
    - Rexroth IndraControl V 105
    - With motor filters HMF01 102
- Commutation drops 50
- Compatibility with foreign matters 38
- Components
  - Arranging the components in the control cabinet 145
  - Main dimensions of the system components 145
  - Performance-dependent arrangement 158
  - Short designations 341
- Connected load
  - Mains, maximum 57
- Connection
  - Control voltage 192
  - DC bus 187
  - Ground connection 182
  - Mains choke 186
  - Motor 195
- Connection cables
  - To motor 106
- Connection point
  - Equipment grounding conductor 182
- Connection points
  - X44 292
- Connections
  - In the drive system 181
- Contactors
  - Selection 65
- Continuous powers in the common DC bus
  - Calculations 333
- Continuous regenerative power
  - Calculations 326
- Control
  - By emergency stop relay 130
  - By the control unit 128
  - Via external mains contactor - HCS02 and HCS03 115
- Control cabinet
  - Arranging the components 145
  - Cooling 171
  - Heat dissipation 171
- Control cabinet adapter
  - HAS03 256
- Control cabinet areas
  - Area A, interference-free 164
  - Area B, interference-susceptible 165
  - Area C, strongly interference-susceptible 166
  - Interference areas 161
- Control cabinet blower 174
- Control circuit
  - Parallel operation 120
- Control circuit position-controlled shutdown
  - Supply unit HMV01.1R with integrated mains contactor 129
- Control circuits
  - For mains connection of Rexroth IndraDrive M supply units 119
  - For the mains connection 111
  - HCS02 with DC bus resistor unit HLB01.1C 117
  - HCS03 with DC bus resistor unit HLB01.1D 117
- Control circuit with DC bus short circuit (ZKS)
  - Supply unit HMV01.1E with integrated mains contactor 123
  - Supply unit HMV01.1R with integrated mains contactor 125, 127
- Control circuit without DC bus short circuit (ZKS)
  - Supply unit HMV01.1E with integrated mains contactor 131
  - Supply unit HMV01.1R with integrated mains contactor 132
  - Supply unit HMV01.1R without integrated mains contactor 133
- Control factor
  - Calculations 329
- Control section
  - In drive controller 9
- Control section CDB01
  - Usage 29
- Control section CSB01
  - Usage 29
- Control section CSH01
  - Usage 29
- Control sections
  - Brief description 29
- Control voltage
  - Connection 192
  - Specification 40
  - Supply 41
  - Supply with control voltage 24 V 43
- Control voltage supply
  - Loop-through contacts 47
- Convection 149
- Cooling
  - Control cabinet 171
- Cooling air current 174
- Cooling units
  - Arrangement 175
- Corner-grounded delta mains 54

- cosφ 57
- CSB01
  - Brief description 29
- CSH01
  - Brief description 29
- C-UL-US listing 33
- D**
- DC bus
  - Connection 187
- DC bus capacitors
  - Discharging 351
- DC bus capacitor unit HLC01
  - Brief description 31
- DC bus continuous power
  - Calculations 319
- DC bus peak power
  - Calculations 322
- DC bus resistor unit HLB01
  - Brief description 30
- Declaration of Conformity 33
- Devices
  - Short designations 341
- Dimensions
  - Main dimensions of the system components 145
- Discharging device 351
- Distance 146
  - Between the devices 146
  - Lateral 149
  - To the bottom 147
  - To the top 147
- Distortion factor 57, 345
  - Calculations 332
- DLT
  - Brief description 27
- Documentation
  - Changes 11
  - Purpose 11
- Documentations
  - Overview 12
  - Reference 12
- DPF
  - Calculations 332
- Drive controller
  - Basic design 8
  - Control section 9
  - Determine appropriate drive controller 319
  - HCS02, brief description 30
  - HCS03, brief description 30
  - HMD01, brief description 29
  - HMS01, brief description 29
  - HMS02, brief description 29
  - Power section 8
- Drive controllers
  - Multiple-line arrangement 178
- Drive system
  - Combination of components 71
  - Configuration 71
  - Connections 181
  - Rexroth IndraDrive C 1
  - Rexroth IndraDrive M 3
  - Rexroth IndraDrive Mi 5
- Drive system Rexroth IndraDrive
  - Applications 27
- DST
  - Brief description 27
- Duty cycle ED
  - Relative 328
- E**
- Electromagnetic compatibility (EMC) 137
- EMC 137
  - EMC-optimal installation in facility and control cabinet 160
- EMC measures
  - For design and installation 159
- Emergency stop relay
  - Control without DC bus short circuit (ZKS) 130
- EMI 137
- Encoder emulation
  - Voltage signal level converter 273
- Encoder systems
  - Optional module encoder evaluation 103
- EnDat 103
- End piece
  - Use 202
- End Piece
  - Mounting 228
- ePlan macros 200
- Equipment grounding conductor
  - Connection 66
  - Connection point 182
  - Connections 184
  - Cross section 184
- Extension
  - For HNK01 mains filters and HCS03 mains input 272
- F**
- Fiber optic cable
  - Accessories 305
- Fiber optic cable connection
  - Accessories 305
- Fields of application
  - Drive system Rexroth IndraDrive 27
- Foreign matters
  - Compatibility with 38
- Functions 11
- Fusing
  - Selection 65

## Index

**G**

- G1, G2, G3, G4, G5
  - Mounting positions 37
- Ground connection
  - Of Housing 182
- Ground connections 167
- Ground resistance
  - Maximum allowed 65

**H**

- HAB01
  - Brief description 31
- HAC01
  - Brief description 32
- Hall sensor box 103
- Hall sensor box SHL01
  - Brief description 32
- Harmonic content, 345
  - Calculations 332
- Harmonics
  - Emitted 344
  - Mains current 345
  - Mains voltage 349
- HAS
  - Brief description 32
- HAS01
  - Assignment 202
  - Basic accessories 201
- HAS02
  - Shield connection 228
  - Shield connection with accessory HAS02 196
- HAS03
  - Control cabinet adapter 256
- HAS04
  - Capacitor 260
  - Use 93
- HAS05
  - Overview 268
- HAS05.1-
  - 001 270
  - 002 272
  - 003 273
  - 005 285
  - 006 290
  - 007 295
  - 008 302
- HCS
  - Central supply 77
  - Parallel operation 83
  - Supply unit 77
- HCS02
  - Brief description 30
  - Central supply, number 80
- HCS03
  - Brief description 30
  - Central supply, number 81

## Heat dissipation

- Control cabinet 171
- Hierarchical levels 1
- High-voltage test 39
- HIPERFACE 103
- HLB01
  - Brief description 30
- HLC01
  - Brief description 31
- HLR01
  - Brief description 30
- HMD01
  - Brief description 29
- HMF01
  - Brief description 31
- HMS01
  - Brief description 29
- HMS02
  - Brief description 29
- HMV
  - Central supply 73
  - Central supply, number 75
- HMV01
  - Brief description 29
- HMV02
  - Brief description 29
- HNF
  - Brief description 27
- HNF01
  - HAS04 required 93
  - Minimum capacitance 93
- HNK
  - Brief description 27
- HNL
  - Brief description 28
- HNS02
  - Brief description 27
- Housing HAC01 for control sections
  - Brief description 32

**I**

- Impulse withstand voltage 349
- Inappropriate use, 16
  - Consequences, exclusion of liability 15
- IndraDrive
  - Hierarchical levels 1
- IndraDyn H 109
- Inductance per unit length 108
- Industrial sectors 27
- Inrush current
  - Calculations 331
- INS0610 305
- Installation
  - EMC-optimal 160
- Installation conditions 36
- Insulation monitoring devices 69
- Introducing the system 1

**ISCCR**

Short-circuit current ratio 56

IT mains type 52

**K****k**

Distortion factor 345

Kind of supply

For power sections 71

**L**

Leakage capacitance

Calculations 335

Leakage currents

Cause 67

**M****Mains**

Maximum connected load 57

Measures for compliance with allowed THD or distortion factor 57

Selecting mains connection components 58

With grounded outer conductor 54

Mains and motor connection

Adapter HAS05.1-001 270

Mains choke

Connection 186

Mains choke HNL

Calculations 334

Mains chokes

Brief description 28

Mains circuit breaker

Ground resistance 65

Selection 65

Mains classes 56

Mains connected load 57

Mains connection

Calculations 330

Control circuits 111

Protection systems 60

Requirements 49

With HNL mains chokes, HNF mains filters and

HNK mains chokes 85

Mains contactor, 111

Additional 114

Control by the control unit 128

Control via external mains contactor - HCS02

and HCS03 115

Redundant 114

Selection 65

Suppressor circuit 112

Mains filter

Connection 186

Motor blower 164

Other loads 165

Selection 334

**Mains filters**

Brief description 27

Operating data, allowed 336

Mains harmonics 50

Calculations 332

Emitted 344

Mains overvoltages

Maximum allowed 50

Mains short-circuit power 55

Mains short-circuit ratio 57

Mains transformers

Brief description 27

Mains types 51

Mains voltage

Harmonics 349

Mains voltage unbalance 333

Master-slave 120

Measures of radio interference suppression

General measures of radio interference suppression for relays, contactors, switches, chokes, inductive loads 169

Minimum capacitance

At the DC bus 93

Use of HNF01 93

Minimum inductance 57

Module bus

Connection 195

Extension 309

Motor

Connection 195

IndraDyn H 109

Third-party motors 313

Motor blower

Mains filter 164

Motor cable

Allowed length 107

Connection to drive controller 195

Cross section 107

Motor cables

Capacitance per unit length 108

Connected in parallel 108

Inductance per unit length 108

Unshielded 108

Motor cables connected in parallel 108

Motor encoder systems

Optional module encoder evaluation 103

Motor filters HMF01, 102

Brief description 31

Motor holding brake

Voltage drop 108

Motors

Capacitance 342

Mounting

Bar 228

Boring dimensions for the mounting plate 150

End Piece 228

Mounting position

Definitions 37

## Index

Multiple-line arrangement of drive controllers 178

**N**

## NFD

Brief description 27

## NFE

Brief description 27

## Noise emission

Measures to reduce 143

Noise emission of the drive system 138

Noise immunity in the drive system 137

**O**

Operating conditions 36

Operator terminals 105

Overvoltage limiters 51

**P**

## Parallel operation

HCS02 with HCS02 82

HCS03 with HCS03 82

HMV 75

Number of components HCS 83

Number of HMVs 76

Parallel operation HMV01 120

## Peak regenerative power

Calculations 329

## Phase current

Calculations 330

## Power consumption

Maximum 45

Typical 45

## Power dissipation

Calculations 324

Power factor  $\cos\phi$ 

Calculations 333

Power factor  $\cos\phi_1$ 

Calculations 332

## Power factors 344

## Power supply

Switching off 113

Switching on 113

## Power voltage

Power voltage supply 49

## Products

Short designations 341

## Protection systems

At the mains connection 60

Protective grounding 60

**R**

RCCB 67

RCD 67

RD500

Supply unit 83

## Regenerative power

Calculations 323

Residual-current-operated circuit breakers 67

Resolver 103

Rexroth IndraDrive C 1

Rexroth IndraDrive M 3

Rexroth IndraDrive Mi 5

RKB0001 309

RKO0100 305

RKO0101 305

RS232/485

Signal level converter 285

**S**

Safety instructions for electric drives 17

Scope of supply

HAS01 203

SERCOS analog converter 105

Shield connection

Accessory HAS02 228

Motor cable 195

SHL01, 103

Brief description 32

Short-circuit current

Symmetrical 56

Short designations 341

Short-time interruptions 50

Signal level converter

Voltage signal level converter (for encoder emulation) 273

Signal level converter RS232/485 285

Signal lines

Installation 168

Simultaneity factor 321

Specifications

Of the components 33

State-of-the-art 15

Storage

Of the components 35

Supply

With control voltage 24 V 43

With power voltage 49

Supply unit

HMV01, brief description 29

HMV02, brief description 29

Switching off

Power supply 113

Time behavior 134

Switching on

Power supply 113

Time behavior 134

System connections 181

Position 181

System impedance 56

System platform 1

**T**

TERM

HAS05.1-005 286

**Termination**

HAS05.1-005 286

THD 57, 332, 345

Third-party motors 313

Third-party supply units 83

**Time behavior**

When switching on and off 134

TN-C mains type 52

TN-S mains type 51

Total Harmonic Distortion (THD) 332

TPF 57

TPF ( $\lambda$ )

Calculations 333

**Transport**

Of the components 35

TT system 54

Type current 9

Type performance 9

**U**

Ungrounded mains 52

**Use**

Appropriate use 15

Inappropriate use 16

**V**

VCP 105

Voltage drop 108

Voltage drops 50

Voltage pulse 349

**W**

Wattless power load

Calculations 332

**X**

X44 292





## Notes

Bosch Rexroth AG  
Bgm.-Dr.-Nebel-Str. 2  
D-97816 Lohr a. Main  
[service.svc@boschrexroth.de](mailto:service.svc@boschrexroth.de)  
[www.boschrexroth.de](http://www.boschrexroth.de)