

## User Guide

# DigitAx

AC Servo Drive  
1.4kW to 22kW

Part Number: 0415-0008  
Issue Number: 4

## General information

The manufacturer accepts no liability for any consequences resulting from inappropriate, negligent or incorrect installation or adjustment of the optional operating parameters of the equipment or from mismatching the variable speed drive (Drive) with the motor.

The contents of this User Guide are believed to be correct at the time of printing. In the interests of a commitment to a policy of continuous development and improvement, the manufacturer reserves the right to change the specification of the product or its performance, or the contents of the User Guide, without notice.

All rights reserved. No parts of this User Guide may be reproduced or transmitted in any form or by any means, electrical or mechanical including photocopying, recording or by any information-storage or retrieval system, without permission in writing from the publisher.

## Important...

### Drive software version

This product is supplied with the latest version of user-interface and machine-control software. If this product is to be used in a new or existing system with other DigitAx Drives, there may be some differences between their software and the software in this product. These differences may cause this product to function differently. This may also apply to Drives returned from a Control Techniques Service Centre.

If there is any doubt, contact a Control Techniques Drive Centre.

## Use within the European Union, etc

The following information applies where the end use of the Drive is within the European Union, the European Economic Area, or other regions which have implemented Directives of the European Council or equivalent measures.

The Drive complies with the Low Voltage Directive 73/23/EEC.

The installer is responsible for ensuring that the equipment into which the Drive is incorporated complies with all relevant Directives.

The complete equipment into which the Drive is incorporated must comply with the EMC Directive 89/336/EEC.

If the Drive is incorporated into a machine, the manufacturer is responsible for ensuring that the machine complies with the Machinery Directive 98/37/EC. In particular, the electrical equipment should generally comply with European Harmonised Standard EN60204-1.

Copyright © January 1999  
Control Techniques Drives Ltd  
Author: RFD  
Issue Code: dgxu4  
Issue Date: January 1999  
S/W Version: V04.XX.XX

---

# Contents

---

<b>1</b>	<b>Introduction</b>	<b>1-1</b>	<b>4</b>	<b>Mechanical Installation</b>	<b>4-1</b>
1.1	Case styles	1-1	4.1	EMC wiring recommendations	4-1
1.2	Method of operation	1-2	4.2	Planning the installation	4-2
1.3	How best to use this User Guide	1-2	4.3	Environment	4-4
<b>2</b>	<b>Safety Information</b>	<b>2-1</b>	4.4	RFI filters	4-4
<b>3</b>	<b>Data</b>	<b>3-1</b>	4.5	Ferrite absorber ring	4-4
3.1	Model range	3-1	4.6	Ferrite rings	4-5
3.2	Ingress protection (IP and NEMA 1)	3-1	4.7	Control Keypad	4-5
3.3	AC supply	3-1	4.8	Installing an external DC braking resistor	4-6
3.4	Drive output	3-1	4.9	Installing a DC bus choke	4-6
3.5	Ambient temperature and humidity	3-1	4.10	Heat dissipation in a sealed enclosure	4-6
3.6	Derating	3-1	4.11	Heat dissipation in a ventilated enclosure	4-7
3.7	Starts per hour	3-1	4.12	Motor cooling	4-7
3.8	PWM switching frequencies	3-1	<b>5</b>	<b>Electrical Installation</b>	<b>5-1</b>
3.9	Vibration	3-1	5.1	Hazardous areas	5-1
3.10	Serial communications	3-2	5.2	Access to the power connectors	5-1
3.11	Resolver specification	3-2	5.3	EMC wiring recommendations	5-3
3.12	Resolver resolution	3-2	5.4	AC supply cables and fuses	5-8
3.13	Response times	3-2	5.5	Ground connections	5-8
3.14	Electromagnetic compatibility (EMC)	3-2	5.6	DC bus choke	5-8
3.15	Frequency accuracy	3-3	5.7	Protecting the Drive with line reactors	5-8
3.16	Weights	3-3	5.8	Connecting an internal or external braking resistor	5-9
3.17	Power ratings	3-3	5.9	Example calculations for a braking resistor	5-12
3.18	Losses and efficiency	3-3	5.10	Control Keypad connections	5-14
3.19	DC bus choke ratings	3-4	5.11	Signal connections	5-15
3.20	Dimensions	3-4			

<b>6</b>	<b>Control Keypad</b>	<b>6-1</b>	<b>11</b>	<b>List of Parameters</b>	<b>11-1</b>
6.1	Models DBE140, DBE220, DBE420, DBE600, DBE750, DBE1100S	6-1	11.1	Variable parameters	11-1
6.2	Models DBE1500, DBE2200	6-1	11.2	Bit parameters	11-5
6.3	Display and controls	6-1	11.3	Summary of default values	11-11
<b>7</b>	<b>Parameters</b>	<b>7-1</b>	<b>12</b>	<b>Trip codes and Fault Finding</b>	<b>12-1</b>
<b>8</b>	<b>Programming Instructions</b>	<b>8-1</b>	12.1	Trip codes	12-1
8.1	Displaying a parameter	8-1	12.2	Fault finding	12-2
8.2	Changing a parameter value	8-1	<b>13</b>	<b>Serial Communications</b>	<b>13-1</b>
8.3	Saving parameter values	8-1	13.1	Introduction	13-1
<b>9</b>	<b>Security</b>	<b>9-1</b>	13.2	Connecting the Drive	13-1
9.1	Setting up a security code	9-1	13.3	Serial communications connector	13-1
9.2	Security access	9-1	13.4	Serial communications configuration	13-1
9.3	Changing a security code	9-1	13.5	Message structure	13-2
<b>10</b>	<b>Getting Started</b>	<b>10-1</b>	13.6	Messages from host to Drive	13-3
10.1	Setting jumpers	10-1	13.7	Write data to the Drive	13-3
10.2	Setting parameter values	10-1	13.8	Terminal mode	13-4
10.3	Protection parameters	10-2	13.9	Parameters related to serial communications	13-5
10.4	PID parameters	10-3	<b>Appendix A</b>	<b>PID Loop</b>	<b>A1</b>
10.5	Speed calibration	10-3	A.1	Setting the PID gains	A-1
10.6	Resolver phasing	10-4	A.2	Evaluating the PID gains	A-2
10.7	Commissioning	10-4	A.3	Setting the bandwidth limit	A-2
10.8	Calibration	10-5			
10.9	Methods of speed control	10-6			
10.10	Methods of torque control	10-7			
10.11	Methods of position control	10-8			
10.12	Quick reference	10-10			
10.13	Programmable outputs	10-11			

# Declaration of Conformity

**Control Techniques plc**  
**The Gro**  
**Newtown**  
**Powys**  
**UK**  
**SY16 3BE**



**W. Drury**  
**Technical Director**  
**Newtown**

**Date: 11th November 1998**

DBE140	DBE220	DBE420
DBE600	DBE750	DBE1100S
DBE1500	DBE2200	

The DigitAx servo drive products listed above have been designed and manufactured in accordance with the following European harmonised, national and international standards:

EN60249	Base materials for printed circuits
IEC326-1	Printed boards: general information for the specification writer
IEC326-5	Printed boards: specification for single- and double-sided printed boards with plated-through holes
IEC326-6	Printed boards: specification for multilayer printed boards
IEC664-1	Insulation co-ordination for equipment within low-voltage systems: principles, requirements and tests
EN60529	Degrees of protection provided by enclosures (IP code)
UL94	Flammability rating of plastic materials
UL508C *	Standard for industrial control equipment

\* Applies to models DBE1500 and DBE2200 only

These products comply with the Low Voltage Directive 73/23/EEC and the CE Marking Directive 93/68/EEC.

**These electronic Drive products are intended to be used with an appropriate motor, controller, electrical protection components and other equipment to form a complete end product or system. The Drive must be installed only by a professional assembler who is familiar with the requirements for safety and electromagnetic compatibility (EMC). The assembler is responsible for ensuring that the end product or system complies with all the relevant laws in the country where it is to be used. This User Guide or the related EMC Data Sheet should be referred to for further information on the EMC standards that the product complies with, as well as for guidance on installation.**



---

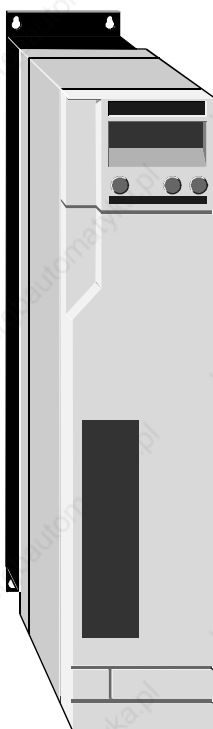
# 1 Introduction

---

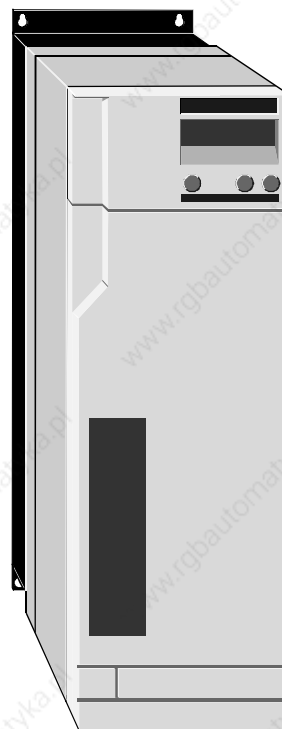
## 1.1 Case styles

Eight DigitAx models cover the range of power ratings. There are two styles and three sizes of case which depend on the power rating of the model. Size 1 and size 2 cases have ingress protection to IP20; size 3 case to IP00

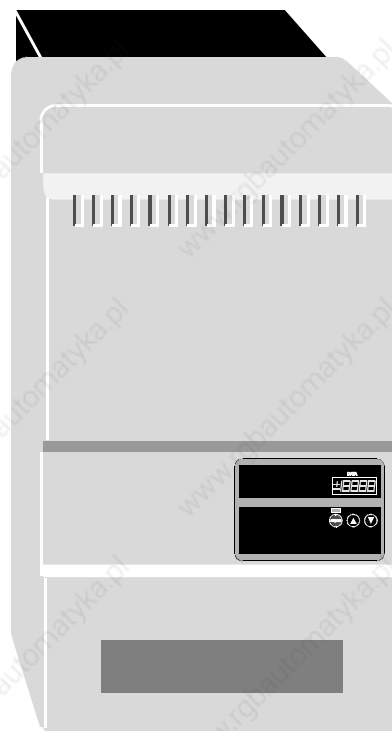
The model in the size 1 case is cooled by natural convection. The models in sizes 2 and 3 cases are fan cooled.



**Figure 1-1** Size 1 case used on models DBE140, DBE220



**Figure 1-2** Size 2 case used on models DBE420, DBE600, DBE750, DBE1100S



**Figure 1-3** Size 3 case used on models DBE1500, DBE2200

## 1.2 Method of operation

### Power circuits

The AC supply is rectified and smoothed to apply a constant voltage on a DC bus. This DC bus supplies a pulse-width modulated IGBT power stage that delivers AC power at variable frequency and voltage to the motor.

Depending on the model, an external DC choke is required for the DC bus.

In order to enhance the braking capabilities of the Drive, all but the two most powerful models have an internal braking resistor, and all models can be used with an external braking resistor.

When the recommended wiring techniques are used, the Drive retains EMC compatibility.

### Controlling the Drive

Operation of the Drive is controlled by programming a number of software parameters. These parameters have default values that enable the Drive to be run without any initial programming.

The Drives have a Control Keypad which is located on the front panel of the case. The Control Keypad is used for the following:

- To change parameter values
- To stop and start the Drive
- To display the operating status of the Drive

An RS485 serial communications port allows the Drive to be controlled remotely using a host PC or plc.



### Warning

**Enabling the Drive when zero speed reference is applied can sometimes cause the motor shaft to be rotated in either direction by up to 10°. Even though all DigitAx Drives are affected in this way, only a small percentage cause rotation in excess of 2°. This effect is caused by tolerances in the current sensors.**

**The effect is usually of no consequence when the motor is driving a belt or gearbox, but may sometimes cause problems in applications involving material held in tension (eg. film).**

**If the effect is likely to be unacceptable for the application, before installing the Drive refer to this User Guide for making just basic AC power and signal connections, and test the Drive for the effect.**

**If necessary, obtain a replacement Drive.**

## 1.3 How best to use this User Guide

This User Guide is arranged logically: reading from beginning to end will take you in the correct order through the basic steps of installing the Drive and getting it running with a motor.

To make subsequent adjustments to the parameters, refer to Chapter 11, *List of Parameters*.



---

## 2 Safety Information

---

### 2.1 Warnings, Cautions and Notes

A **Warning** contains information which is essential for avoiding a safety hazard.

A **Caution** contains information which is necessary for avoiding a risk of damage to the product or other equipment.

A **Note** contains information which helps to ensure correct operation of the product.

### 2.2 Electrical safety – general warning

The voltages used in the Drive can cause severe electric shock and/or burns, and could be lethal. Extreme care is necessary at all times when working with or adjacent to the Drive.

Specific warnings are given at the relevant places in this User Guide and the accompanying User Guide.

The installation must comply with all relevant safety legislation in the country of use.

### 2.3 System design

The Drive is intended as a component for professional incorporation into complete equipment or systems. If installed incorrectly the Drive may present a safety hazard. The Drive uses high voltages and currents, carries a high level of stored electrical energy, and is used to control mechanical equipment which can cause injury.

Close attention is required to the electrical installation and the system-design to avoid hazards either in normal operation or in the event of equipment malfunction. System-design, installation, commissioning and maintenance must be carried out by personnel who have the necessary training and experience. They must read this safety information and User Guide carefully.

To ensure mechanical safety, additional safety devices such as electro-mechanical interlocks may be required. The Drive must not be used in a safety-critical application without additional high-integrity protection against hazards arising from a malfunction.

### 2.4 Environmental limits

Instructions in this User Guide regarding transport, storage, installation and use of Drives must be complied with, including the specified environmental limits. Drives must not be subjected to excessive physical force.

### 2.5 Compliance with regulations

The installer is responsible for complying with all relevant regulations, such as national wiring regulations, accident prevention regulations and electromagnetic compatibility (EMC) regulations. Particular attention must be given to the cross-sectional areas of conductors, the selection of fuses or other protection, and protective earth (ground) connections.

This User Guide contains instructions for achieving compliance with specific EMC standards.

Within the European Union, all machinery in which this product is used must comply with the following directives:

98/37/EC: Safety of Machinery

89/336/EEC: Electromagnetic Compatibility.

### 2.6 Safety of personnel

The STOP function of the Drive does not remove dangerous voltages from the output of the Drive or from any external option unit.

The Stop and Start controls or electrical inputs of the Drive should not be relied upon to ensure safety of personnel. If a safety hazard could exist from unexpected starting of the Drive, an interlock that electrically isolates the Drive from the AC supply must be installed to prevent the motor being inadvertently started.

Careful consideration must be given to the functions of the Drive which might result in a hazard through incorrect operation due to a fault or trip (eg. stop/start, forward/reverse, maximum speed).

Under certain conditions, the Drive can suddenly discontinue control of the motor. If the load on the motor could cause the motor speed to be increased (eg. hoists and cranes), a separate method of braking and stopping the motor must be used (eg. a mechanical brake).

Before connecting the AC supply to the Drive, it is important that you understand the operating controls and their operation. If in doubt, do not adjust the Drive. Damage may occur, or lives put at risk. Carefully follow the instructions in this User Guide.

Before making adjustments to the Drive, ensure all personnel in the area are warned. Make notes of all adjustments that are made.

## 2.7 Risk analysis

In any application where a malfunction of the Drive could lead to damage, loss or injury, a risk analysis must be carried out, and where necessary, further measures taken to reduce the risk. This would normally be an appropriate form of independent safety back-up system using simple electro-mechanical components.

## 2.8 Motor

Ensure the motor is installed in accordance with the manufacturer's recommendations. Ensure the motor shaft is not exposed.

## 2.9 Adjusting parameters

Some parameters have a profound effect on the operation of the Drive and protection of the motor. They must not be altered without careful consideration of the impact on the controlled system. Measures must be taken to prevent unwanted changes due to error or tampering.

## 3 Data



### Warning

**The voltages present in the Drive are capable of inflicting a severe electric shock and may be lethal. The Stop function of the Drive does not remove dangerous voltages from the Drive or the driven machine.**

**AC supplies to the Drive must be disconnected at least 15 minutes before any cover is removed or servicing work is performed.**

### 3.1 Model range

Model	Case size	Nominal power rating	Current ratings	
			I <sub>nom</sub>	I <sub>pk</sub>
DBE140	1	1.4kW	2.8	5.6
DBE220		2.2kW	4.4	8.8
DBE420	2	4.2kW	8.5	17
DBE600		6kW	13	26
DBE750		7.5kW	16	32
DBE1100S		11kW	26	39
DBE1500	3	15kW	32	48
DBE2200		22kW	48	72

AC supply voltage: 380V to 460V

Maximum duration of I<sub>pk</sub>: 4 seconds

### 3.2 Ingress protection (IP and NEMA 1)

Model sizes 1 and 2 are rated at IP20. The cooling fans for the heatsink are rated at IP20.

Model size 3 are supplied as a stand-alone unit in a protective case having an enclosure specification which is rated as IP00 (in accordance with the IEC529) or NEMA 1. The cooling fans for the heatsink are rated at IP20.

For Drives supplied in an IP00 case, a DC bus choke (inductor) and an optional braking resistor should be installed externally to the Drive. For Drives supplied in a NEMA 1 case, a DC bus choke and braking resistor are installed internally.

### 3.3 AC supply

Balanced 3-phase

50Hz -2Hz to 60Hz +2Hz

380V -10% to 460V +10%

### 3.4 Drive output

Maximum motor speed: 6000 RPM

Maximum output voltage:

Equal to the AC supply voltage

### 3.5 Ambient temperature and humidity

Ambient temperature range:

-10°C to +50°C (14°F to 122°F) non-condensing

Local heat sources (such as other equipment) that raise the air temperature above +50°C (122°F) must be removed.

### 3.6 Derating

Maximum altitude without derating is 1000m (3200ft). Derate full load current (FLC) by 1% for each additional 100m (320ft).

### 3.7 Starts per hour

#### Drive

By switching the supply: 20 per hour

Electronic starts: Unlimited

#### Motor

Refer to motor manufacturer.

### 3.8 PWM switching frequencies

DBE140 to DBE1100S: 8kHz

DBE1500, DBE2200: 4kHz, 8kHz

### 3.9 Vibration

Conformance to the requirements of IEC 68-2-34

### 3.10 Serial communications

RS485 half-duplex (RS422 can also be used)  
Protocol: ANSI x 3.28-2.5-A4-N, positive logic

#### Timing

Write to Drive:

25ms at 9600 Baud  
15ms at 19.2 kBaud

Read from the Drive:

30ms at 9600 Baud  
16ms at 19.2 kBaud

### 3.11 Resolver specification

Voltage	6V RMS
Frequency	10kHz
Primary	Rotor
Number of poles	2
Transformation ratio	0.28 ±10%
Phase shift	-14° nominal
Primary current	40mA nominal
Power input	120mW
Electrical error	±15 minutes
Impedance ZRO	73 + j129 Ω
Impedance ZSO	116 + j159 Ω
Impedance ZSS	95 + j162 Ω
Excitation winding resistance	28Ω
Stator winding resistance	18Ω
Temperature range	-55°C to 155°C -97°F to 240°F
Inertia	2.0gm <sup>2</sup> x 10 <sup>-5</sup>

### 3.12 Resolver resolution

14-bit when **Pr99** < 3200 RPM  
12 bit when **Pr99** ≥ 3200 RPM

### 3.13 Response times

Scanning rate for speed loop	512μs
Scanning rate for current loop	128μs
Sampling time of analogue inputs	512μs
Rise time of digital outputs	10μs
Speed loop resolution	0.01%
Current loop resolution	10 bits
Speed loop bandwidth	320Hz
Current loop bandwidth	2kHz
Max delay of STOP input	15ms
Max delay of limit switch input	2ms
Max delay of external trip input	5ms

### 3.14 Electromagnetic compatibility (EMC)

When all the following conditions are met, the installation can meet the requirements for conducted emissions of EN50081-2:

The specified RFI filter (or ferrite absorber ring and capacitor network) is used

The recommendations for the wiring arrangements are followed

The motor cable passes through a pair of ferrite rings (as specified)

#### Immunity

In accordance with IEC801 without significant disturbance to operation at the following level:

Part 4 (Transient Burst) Level 3

### 3.15 Frequency accuracy

Output frequency is within 100ppm of the demanded frequency.

### 3.16 Weights

The weights of the most powerful model in each model size are as follows:

- Model size 1: 5.5kg (12lb)
- Model size 2: 9.5kg (21lb)
- Model size 3: 22.3kg (49lb)

### 3.17 Power ratings

**Note**

**Power ratings are for typical 3-phase 6-pole DutymAx motors.**

**Displacement factor (fundamental power factor) at input closely approximates to unity, but is dependent on supply impedance.**

**400V nominal supply voltage**

### 3.18 Losses and efficiency

**Note**

**Figures quoted are at maximum output power.**

Model	Total power loss		Efficiency at 460V	
	4kHz (100%)	8kHz (100%)	4kHz	8kHz
	W	W	%	%
DBE140		105		93.0
DBE220		145		94.4
DBE420		220		95.0
DBE600		310		95.1
DBE750		385		95.1
DBE1100S		510		95.5
DBE1500	436	564	97.1	96.4
DBE2200	623	827	97.2	96.4

Model	Output	Motor rating (DutymAx)	Input			
	100% rms Current		100% rms Current	100% fundamental		
	A	Nm	A	A	kVA	kW
DBE140	2.8	4.5	5.3	4.0	3.7	2.8
DBE220	4.4	7.0	7.8	6.3	5.4	4.4
DBE420	8.5	13.6	8.8	10.6	6.1	7.3
DBE600	13	20.8	13.1	15.2	9.1	10.5
DBE750	16	25.6	15.4	19.7	10.7	13.6
DBE1100S	26	41.6	23.7	30.5	16.4	21.1
DBE1500	32	51.2	29.7	39.0	20.6	27.0
DBE2200	48	76.8	44.9	57.5	31.1	39.8

### 3.19 DC bus choke ratings

DC bus chokes are fitted internally on the DBE420 to DBE1100S drives. No DC bus choke is needed for models DBE140 and DBE220.

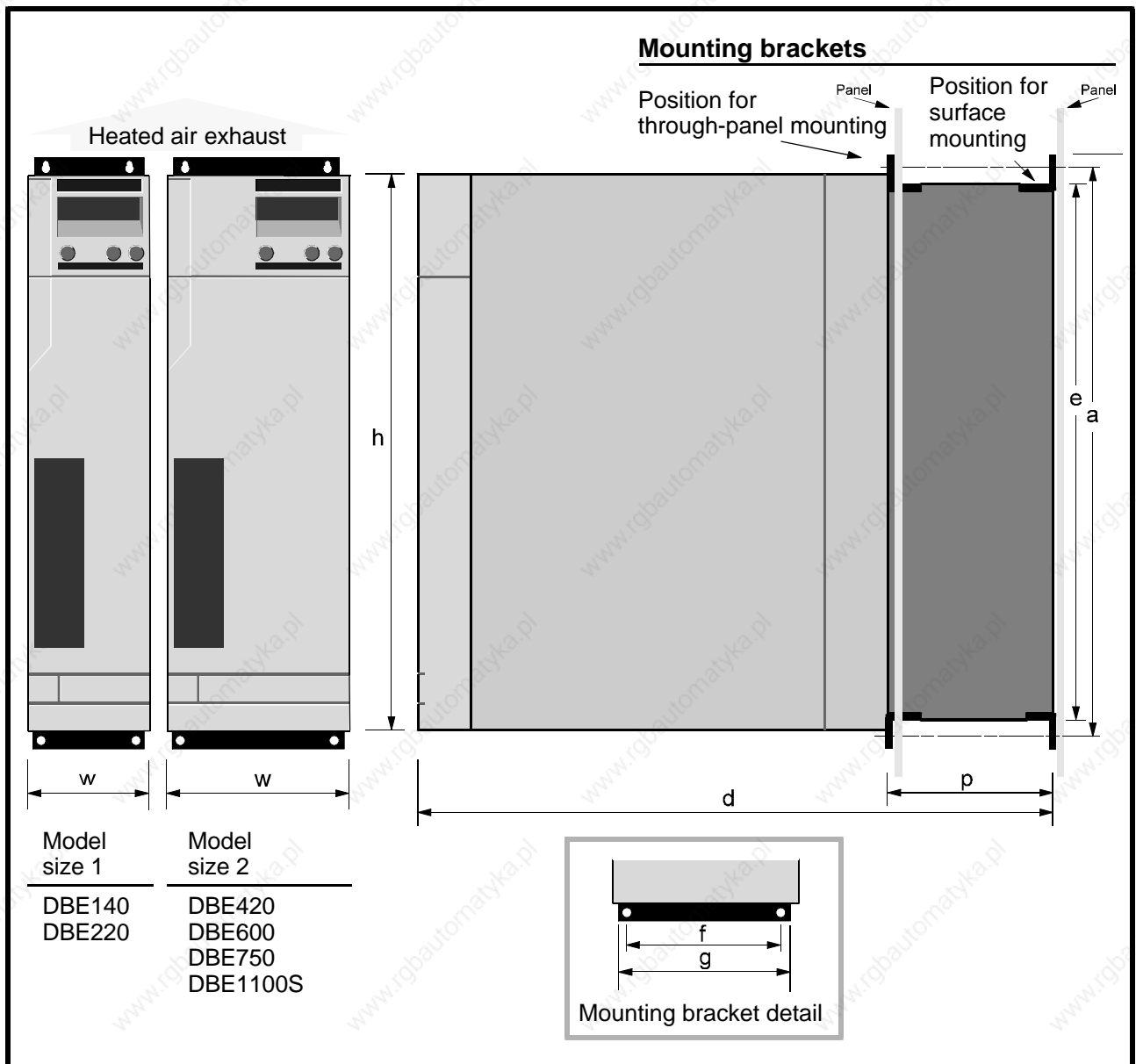
Ripple frequency =  $6 \times$  supply frequency

Ratings and values quoted are design minima.

Drive model	Choke ratings			Weight	
	mH	ARMS	Apk	kg	lb
DBE1500	1.50	45	85	6.4	14
DBE2200	0.70	75	143	8.4	19

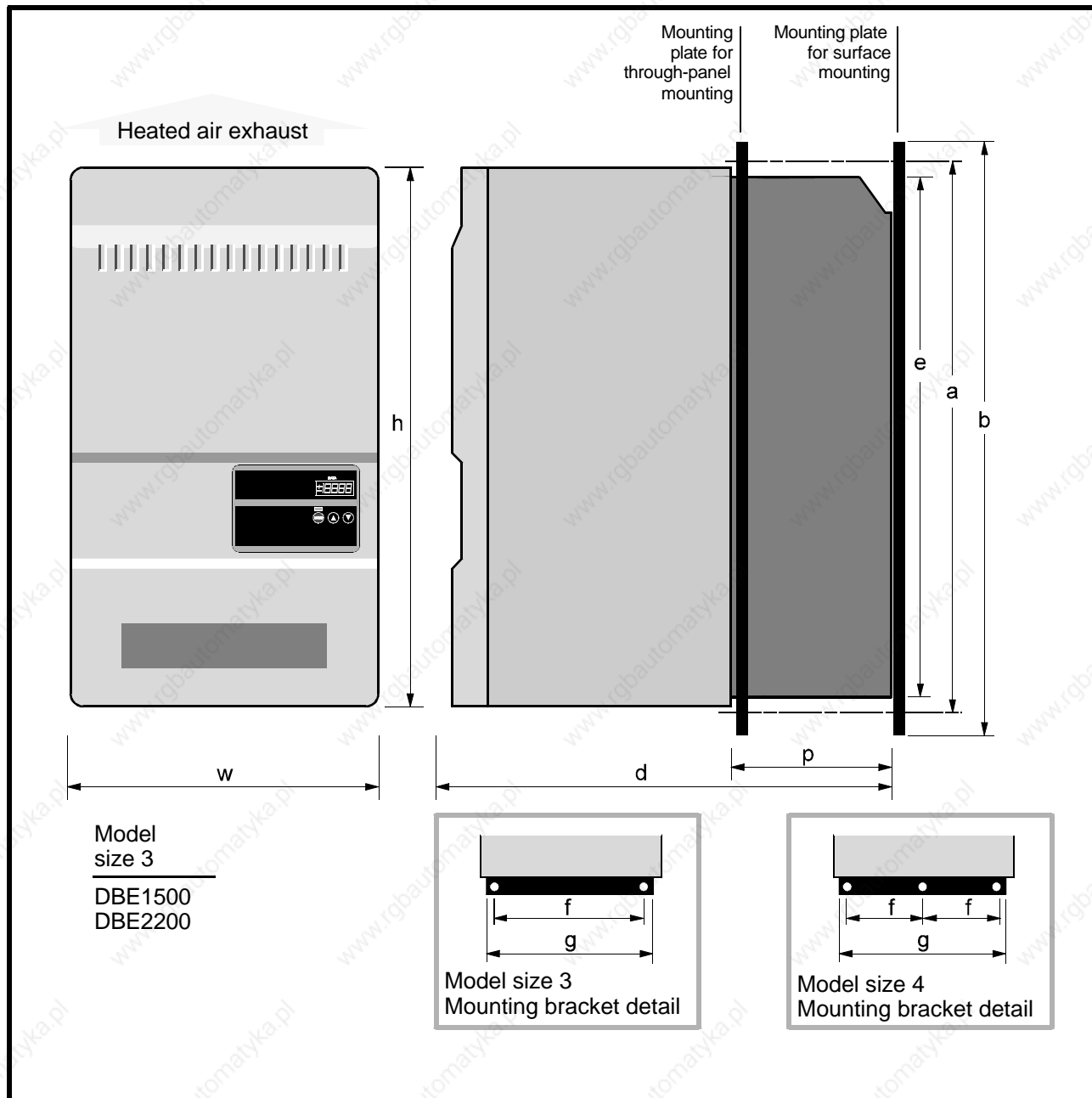
### 3.20 Dimensions

Refer to the following diagrams.



**Figure 3-1** Dimensions of model sizes 1 and 2 (See table on opposite page)

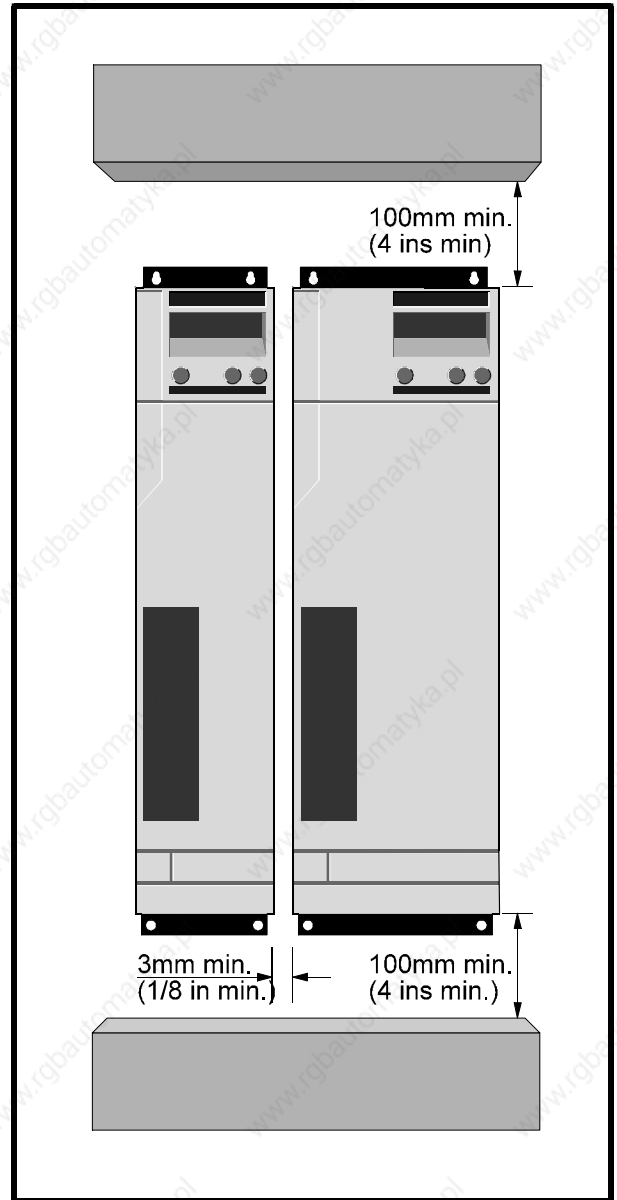
Dimension		Model size 1 DBE140, DBE220		Model size 2 DBE420, DBE600 DBE750, DBE1100S	
		mm	in	mm	in
Height of case	h	352	13 <sup>7</sup> / <sub>8</sub>	352	13 <sup>7</sup> / <sub>8</sub>
Width of case	w	78.5	3 <sup>1</sup> / <sub>16</sub>	127	5
Overall depth	d	323.5	12 <sup>3</sup> / <sub>4</sub>	328.5	12 <sup>15</sup> / <sub>16</sub>
Depth of heatsink	p	95	3 <sup>7</sup> / <sub>8</sub>	100	3 <sup>15</sup> / <sub>16</sub>
Width of heatsink	g	62	2 <sup>7</sup> / <sub>16</sub>	109	4 <sup>5</sup> / <sub>16</sub>
Height of heatsink	e	332	13 <sup>1</sup> / <sub>16</sub>	330	13
Mounting centres top bracket to bottom bracket	a	359.4	14 <sup>1</sup> / <sub>8</sub>	359.4	14 <sup>1</sup> / <sub>8</sub>
Mounting centres of mounting bracket	f	45	1 <sup>3</sup> / <sub>4</sub>	77	3 <sup>1</sup> / <sub>16</sub>
Height of aperture for through-panel mounting		334	13 <sup>1</sup> / <sub>8</sub>	332	13 <sup>1</sup> / <sub>16</sub>
Width of aperture for through-panel mounting		64	2 <sup>1</sup> / <sub>2</sub>	111	4 <sup>3</sup> / <sub>8</sub>
Fixing hole diameter		4mm ( <sup>3</sup> / <sub>16</sub> ins) clear			



**Figure 3-2 Dimensions of model size 3 (See table on opposite page)**



Dimension		Model size 3 DBE1500 DBE2200	
		mm	in
Height of case	h	490	19 <sup>5</sup> / <sub>16</sub>
Width of case	w	330	13
Overall depth	d	283	11 <sup>3</sup> / <sub>16</sub>
Depth of heatsink	p	139	5 <sup>1</sup> / <sub>2</sub>
Height of heatsink	e	466	18 <sup>5</sup> / <sub>16</sub>
Width of heatsink	g	295	11 <sup>5</sup> / <sub>8</sub>
Total height of mounting plates	b	522	20 <sup>9</sup> / <sub>16</sub>
Mounting centres top to bottom	a	502	19 <sup>3</sup> / <sub>4</sub>
Mounting centres	f	248	9 <sup>5</sup> / <sub>16</sub>
Height of aperture for through-panel mounting		468	18 <sup>1</sup> / <sub>2</sub>
Width of aperture for through-panel mounting		296	11 <sup>5</sup> / <sub>8</sub>
Fixing hole diameter		6mm (1/4 in) clear	



**Figure 3–3** Clearances required around the Drive



## 4 Mechanical Installation



### Warning

**The equipment enclosure is rated at IP20 in accordance with IEC539. It is designed for installation within a protective enclosure which prevents unauthorised access except for trained service personnel, and prevents contamination with conductive dust and condensation.**

### 4.1 EMC wiring recommendations

To minimize radio-frequency emissions, it is necessary to install the Drive in a steel enclosure and pay attention to the arrangement of the wiring inside the enclosure. Figure 4-1 shows recommendations for the layout of the enclosure. Figures 5-1 and 5-3 in Chapter 5 *Electrical Installation* show examples of wiring arrangements for minimum radio-frequency emissions. The actual arrangement will have to be adapted to individual requirements.

When planning the installation, refer to Chapter 5 in addition to this chapter.

The essential requirements are as follows:

#### RFI filter

- Mount an RFI filter above the Drive at a distance of 125mm (5 in).
- Make the AC power cables from the RFI filter to the Drive as short as possible.
- Use a flat conductor at least 10mm ( $\frac{1}{2}$ in) wide and as short as possible to make the ground connection from the RFI filter to the Drive.

#### Motor cable

- Use armoured or shielded cable to connect the motor to the Drive. Connect the armour or shield to the Drive and to the motor frame. Make these connections no longer than 50mm (2in).
- If the length of cable used to connect the motor to the Drive exceeds 50m (150 feet), output chokes may be required in order to prevent cable capacitance effects causing over-current trips (**OC**) in the Drive. For difficult cases, consult the supplier of the Drive.

#### Resolver wiring Simulated-encoder wiring

- Signal connections from the resolver and from the simulated encoder input of the CNC controller must be connected to the Drive using cable consisting of three twisted-pairs of wire. Each twisted pair must be screened, and the cable must have an overall screen. Connect the screens of the resolver cable only to terminal B18 of the Drive. Connect the screens of the simulated encoder output only to the CNC controller ground terminal.
- When a motor thermistor is to be used, connect it to the Drive using a fourth twisted-pair in the screened cable to the resolver. Connect the screen for this twisted-pair only to terminal B18 on the Drive.

#### Analog speed reference wiring

- Use shielded twisted-pair cable to connect the analog speed reference to the Drive. It is strongly recommended that a true differential signal source is used in order to maximize immunity to electrical noise. Connect the cable shield only to the ground connection of the CNC controller.
- A single-ended signal source may be used, but electrical noise immunity is reduced. Use shielded twisted-pair cable. Apply the signal to terminal B9 or B10 of the Drive, as required. Connect the 0V common to terminal B11. Connect the unused differential input (terminal B10 or B9) to terminal B11.

#### Ground connections

- Bus-bars must be used to make certain ground connections, as shown in Figure 5-4. These bus-bars must be made of copper bar of the dimensions shown.

#### Ferrite absorber ring

- When a number of Drives are installed in an enclosure, it is recommended that a ferrite absorber ring is fitted over the AC supply cables to each Drive. (See also *Capacitor network*.)
- Part number: 4200-3608

#### Capacitor network

- When three or more Drives are installed in an enclosure, a capacitor network may be required. Refer to Figure 5-4.

## 4.2 Planning the installation

The following conditions must be met when planning the installation of the Drive or a number of Drives in an enclosure:

- The environment is acceptable
- The maximum permissible ambient temperature is not exceeded
- The EMC requirements are met
- The electrical installation meets safety requirements
- The size of the installation does not exceed the space available

Use the following procedure:

1. Decide how the Drives are to be mounted in the enclosure, as follows:
  - Surface-mounted
  - Through-panel mounted

Surface mounting gives the following:

Better ingress protection  
Heat dissipated inside the enclosure

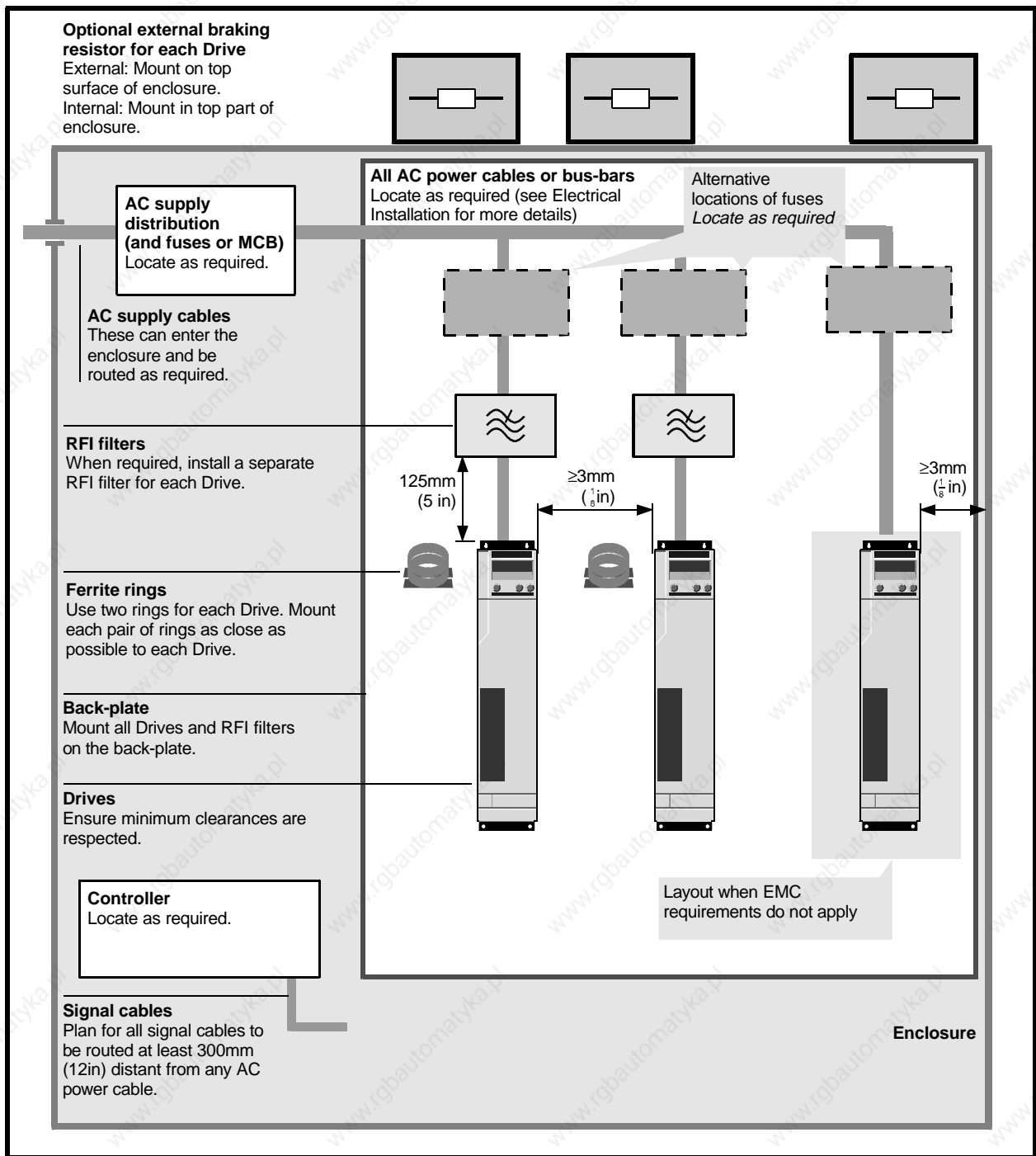
Through-panel mounting gives the following:

Heat dissipated outside the enclosure  
Reduced ingress protection

2. Refer to Figure 4–1 to plan the layout of the equipment in the enclosure.
3. If the Drives are to be surface mounted in the enclosure, refer to either of the following:

If the enclosure is to be sealed, perform the calculations in *Heat dissipation in a sealed enclosure* in order to determine the minimum permissible size of enclosure for heat dissipation.

If the enclosure is to be ventilated, perform the calculation in *Heat dissipation in a ventilated enclosure* in order to determine the required volume of air-flow.
4. If necessary, adjust the size of the enclosure, and re-plan the internal equipment accordingly. Repeat instructions **2** to **4** as many times as required to meet all the requirements.



**Figure 4-1 Planning the layout of the enclosure**

### 4.3 Environment

1. In accordance with the IP20 rating of the Drive, the Drive must be located in an environment that is free from dust, corrosive vapours, gases and all liquids, including condensation of atmospheric moisture.
2. If condensation is likely to occur when the Drive is not in use, install an anti-condensation heater. This heater must be switched off when the Drive is in use; automatic switching is recommended.
3. Do not locate the Drive in a classified hazardous area, unless the Drive is installed in an approved enclosure and the installation is approved.
4. Install the Drive vertically for best flow of cooling air.
5. Install the Drive as low as possible in the enclosure without contravening EMC requirements.
6. Observe the requirements for ambient temperature if the Drive is to be mounted directly above any heat generating equipment, such as another Drive.
7. If the Drive is to be installed directly beneath other equipment, such as another Drive, ensure the Drive does not cause the ambient temperature requirements of the equipment to be exceeded.
8. Allow at least 100mm (4in) clearance above and below the Drive.
9. Allow at least 3mm ( $\frac{1}{8}$ in) clearance each side of the Drive.

### 4.4 RFI filters

Install the RFI filter specified for the Drive model as follows. Use one RFI filter for each Drive. (Ferrite absorber rings and a capacitor network can be used in place of an RFI filter. See *Ferrite absorber rings* below.)

Drive model	Filter part number
DBE140	4200-4810
DBE420	4200-4810
DBE420	4200-4810
DBE600	4200-4820
DBE750	4200-4820
DBE1100S	4200-4830
DBE1500	4200-1051
DBE2200	4200-1051

Filter part number	Filter dimensions					
	Length		Width		Depth	
4200-	mm	in	mm	in	mm	in
4810	250	$9\frac{15}{16}$	110	$4\frac{3}{8}$	60	$2\frac{3}{8}$
4820	270	$10\frac{3}{4}$	140	$5\frac{9}{16}$	60	$2\frac{3}{8}$
4830	270	$10\frac{3}{4}$	140	$5\frac{9}{16}$	60	$2\frac{3}{8}$
1051	330	13	190	$7\frac{5}{8}$	145	$5\frac{11}{16}$

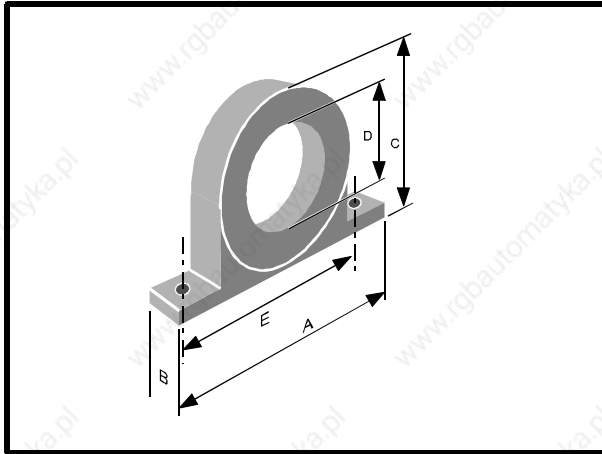
### 4.5 Ferrite absorber ring

A ferrite absorber ring and capacitor network may be used in place of an RFI filter for all models, except for models DBE1500 and DBE2200. See Figure 5-4.

## 4.6 Ferrite rings

The three conductors of the motor cable from each Drive must pass twice through two ferrite rings, as shown in Figures 5–2 and 5–3.

Part number: 4200-0000

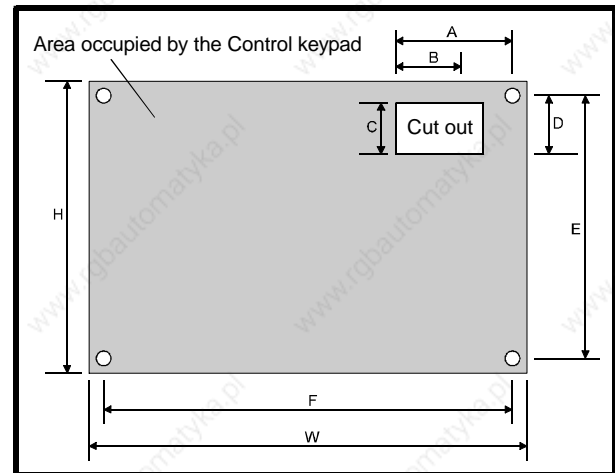


Dimension	mm	in
A	105	4 <sup>3</sup> / <sub>16</sub>
B	24	1
C	62	2 <sup>1</sup> / <sub>2</sub>
D	28.5	1 <sup>1</sup> / <sub>8</sub>
E	90	3 <sup>5</sup> / <sub>8</sub>
Mounting hole diameter	5	<sup>3</sup> / <sub>16</sub>

**Figure 4–2** Dimensions of the ferrite rings

## 4.7 Control Keypad

For model size 3, the Control Keypad is a plug-in unit which can be detached from the Drive for mounting in a panel. Holes are required in the panel for the fixing studs and connector which project from the rear of the Control Keypad housing. Refer to Figure 4–3.



Dimension	mm	in
A	65.0	2 <sup>9</sup> / <sub>16</sub>
B	40.0	1 <sup>9</sup> / <sub>16</sub>
C	26.0	1 <sup>1</sup> / <sub>16</sub>
D	22.0	<sup>7</sup> / <sub>8</sub>
E	97.0	3 <sup>13</sup> / <sub>16</sub>
F	146.5	5 <sup>3</sup> / <sub>4</sub>
H	167	6 <sup>9</sup> / <sub>16</sub>
W	114	4 <sup>1</sup> / <sub>2</sub>
Mounting hole diameter	M4	<sup>3</sup> / <sub>16</sub>

**Figure 4–3** Mounting screw holes and dimensions of cut-out required for remote mounting of the Control Keypad

The Control Keypad on model sizes 1 and 2 cannot be located remotely from the Drive.

## 4.8 Installing an external DC braking resistor

When an external braking resistor is to be installed, it should be installed in accordance with the manufacturer's instructions. Refer to *Calculating the braking resistor value* in Chapter 5 *Electrical Installation*.

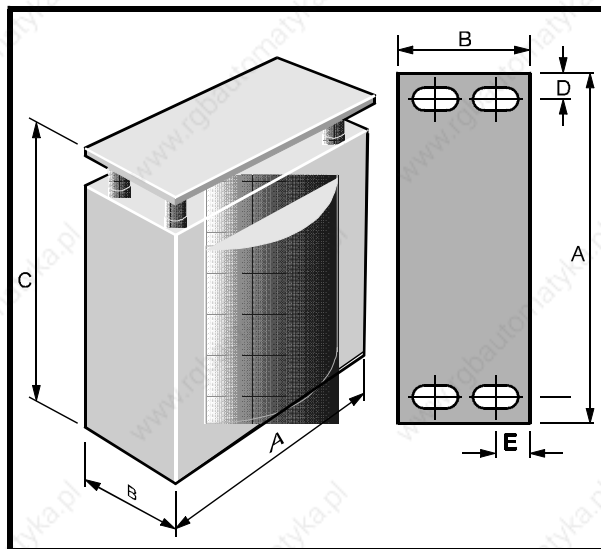
## 4.9 Installing a DC bus choke

For model size 3, an external DC bus choke is required. The choke may be mounted in the same enclosure as the Drive.

No external DC bus choke is required for model sizes 1 and 2.

### Note

**Drives supplied in NEMA 1 case contain the required DC bus choke.**



Value	A	B	C	D	E	Terminal size
mH	mm in	mm in	mm in	mm in	mm in	
1.50	137 5 <sup>7</sup> / <sub>16</sub>	84 3 <sup>5</sup> / <sub>16</sub>	175 6 <sup>7</sup> / <sub>8</sub>	24 1 <sup>5</sup> / <sub>16</sub>	10 3 <sup>3</sup> / <sub>8</sub>	M8
0.70	137 5 <sup>7</sup> / <sub>16</sub>	116 4 <sup>9</sup> / <sub>16</sub>	175 6 <sup>7</sup> / <sub>8</sub>	24 1 <sup>5</sup> / <sub>16</sub>	10 3 <sup>3</sup> / <sub>8</sub>	M8

**Figure 4-4 Dimensions of the DC bus choke**

## 4.10 Heat dissipation in a sealed enclosure

To maintain sufficient cooling of the Drive when it is installed inside a sealed enclosure, heat generated by all the equipment in the enclosure must be taken into account and the enclosure must be of adequate size. To calculate the minimum acceptable size of enclosure, use the following procedure.

Calculate the minimum required surface area  $A_e$  for the enclosure from:

$$A_e = \frac{P}{k(T_i - T_{amb})}$$

where:

- $A_e$  = Unobstructed heat-conducting area in m<sup>2</sup>
- $k$  = Heat Transmission coefficient of the enclosure material in Watts/m<sup>2</sup>/°C
- $T_i$  = Maximum permissible operating temperature in °C of the Drive
- $T_{amb}$  = Maximum external ambient temperature in °C
- $P$  = Power in Watts dissipated by all heat sources in the enclosure

### Example

To calculate the size of an enclosure for one DBE2200 Drive. The following conditions are assumed:

The installation is to conform to IP54, requiring the Drive to be surface-mounted within a sealed enclosure

Only the top, front and two sides of the enclosure are free to dissipate heat

The enclosure is constructed of painted 2mm (<sup>3</sup>/<sub>32</sub> inch) sheet steel

Maximum external ambient temperature: 25°C (77°F)

Drive PWM switching frequency: 8kHz



Insert the following values:

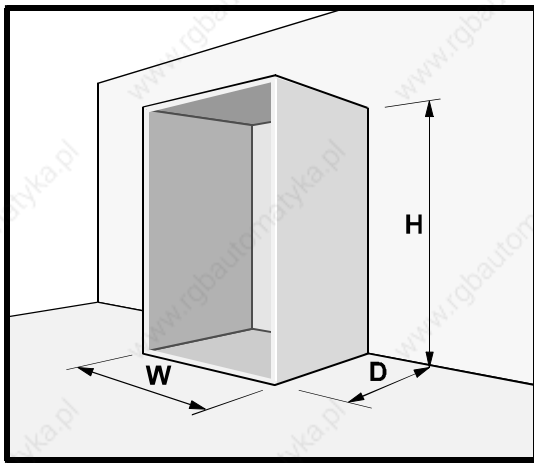
- P** = 827W (from Losses and Efficiency table)
- T<sub>i</sub>** = 50°C (122°F)
- T<sub>amb</sub>** = 25°C (77°F)
- k** = 5.5 (typical value for painted 2mm (1/16 inch) sheet steel)

The minimum required heat conducting area is then:

$$A_e = \frac{827}{5.5(50 - 25)} = 6.0\text{m}^2$$

The unobstructed heat-conducting area of the enclosure is:

$$A_e = 2HD + HW + DW$$



**Figure 4-5 Enclosure having top, sides and front surfaces free to dissipate heat**

Estimate two of the enclosure dimensions – the height and depth, for instance. Calculate the minimum width from:

$$W = \frac{A_e - 2HD}{H + D}$$

Inserting H = 1.8 metres, D = 0.5 metre, obtain the minimum width:

$$W = \frac{6.0 - (2 \times 1.8 \times 0.5)}{1.8 + 0.5} = 1.8 \text{ metres approx}$$

If possible, locate heat-generating equipment in the lower part of the enclosure to encourage internal convection. Otherwise, increase the height of the enclosure or install 'stirrer' fans.

## 4.11 Heat dissipation in a ventilated enclosure

If a high ingress factor is not required, a ventilated enclosure may be used. This will be smaller than a sealed enclosure.

To calculate the minimum required volume of ventilating air, use the following formula:

$$V = \frac{3.1 \times P}{T_i - T_{amb}}$$

where:

- V** = Air-flow in m<sup>3</sup>/hr
- P** = Power in Watts dissipated by all heat sources in the enclosure
- T<sub>i</sub>** = Maximum permissible operating temperature in °C of the Drive
- T<sub>amb</sub>** = Maximum external ambient temperature in °C

### Example

To calculate the ventilation requirement for one DBE1500 Drive:

- P** = 827W
- T<sub>i</sub>** = 50°C
- T<sub>amb</sub>** = 25°C

Then..

$$V = \frac{3.1 \times 827}{50 - 25} = 102.5\text{m}^3 / \text{hr}$$

## 4.12 Motor cooling

When a motor is driven at low speed, its internal cooling fan becomes less effective. If necessary, provide it with additional cooling (such as forced ventilation).



## 5 Electrical Installation



### Warning

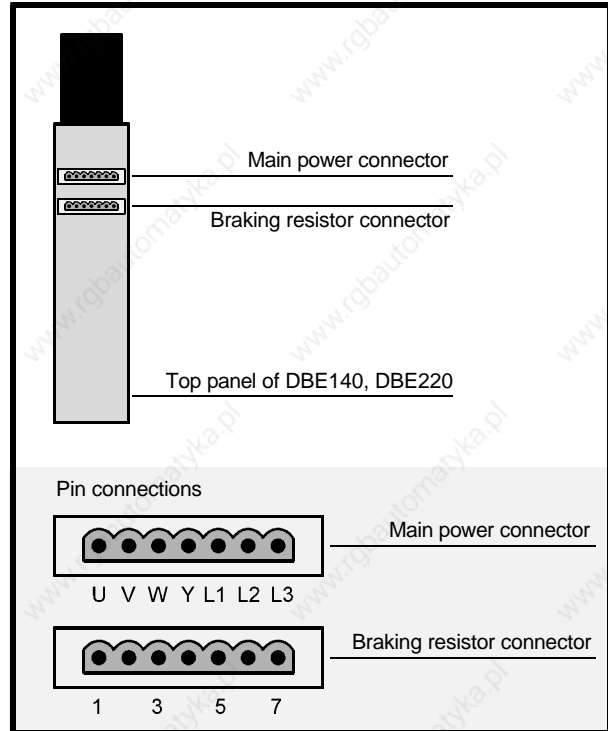
The voltages present in the Drive are capable of inflicting a severe electric shock and may be lethal. The Stop function of the Drive does not remove dangerous voltages from the Drive or the driven machine. AC supplies to the Drive must be disconnected using an approved isolation device before any cover is removed or service work is performed.



### Warning

#### Electric shock risk

If the Drive has been energized, the supply must be isolated for at least fifteen minutes. This allows the internal capacitors to discharge fully before work may continue. Refer to *Safety information on the inside front cover of this user guide.*



**Figure 5-1** Locations of the main power connector and the braking resistor connector on models DBE140 and DBE220

### 5.1 Hazardous areas

Approval and certification for hazardous areas should be obtained for the complete installation of the motor and Drive.

### 5.2 Access to the power connectors

#### DBE140, DBE220

A main power connector and a braking resistor connector are fitted to the top panel of the case. See Figure 5-1.

#### Main power connector

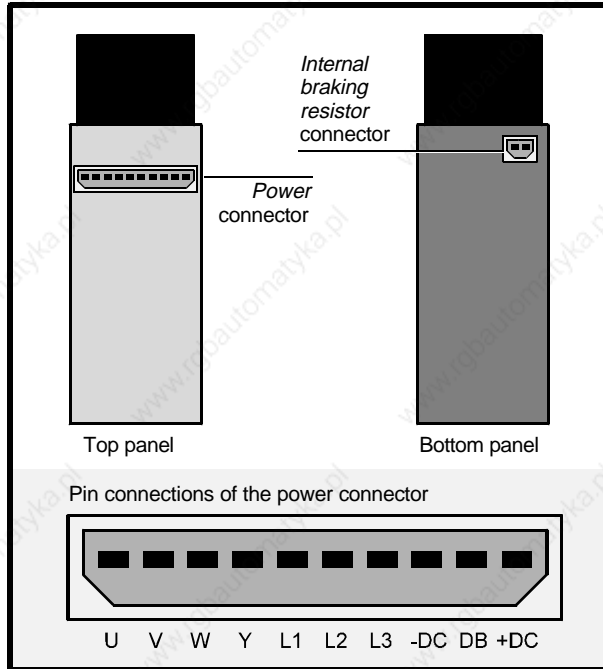
Pin	Function	Type	Notes
U	Phase U	Out	Output to motor
V	Phase V	Out	
W	Phase W	Out	
Y	PE		
L1	Phase L1	In	AC supply
L2	Phase L2	In	
L3	Phase L3	In	

#### Braking resistor connector

Pin	Function	Type	Notes
1	+DC bus	Out	External braking resistor connection
3	Internal braking resistor	Out	Internal braking resistor connection
5	External/Internal braking resistor	Out	Controlled output
7	-DC bus	Out	

## DBE420, DBE600, DBE750, DBE1100S

A power connector is fitted to the top panel of the case; a braking-resistor connector is located on the underside of the case.



**Figure 5-2** Location of the power and braking-resistor connectors on models DBE420, DBE600, DBE750, DBE1100S

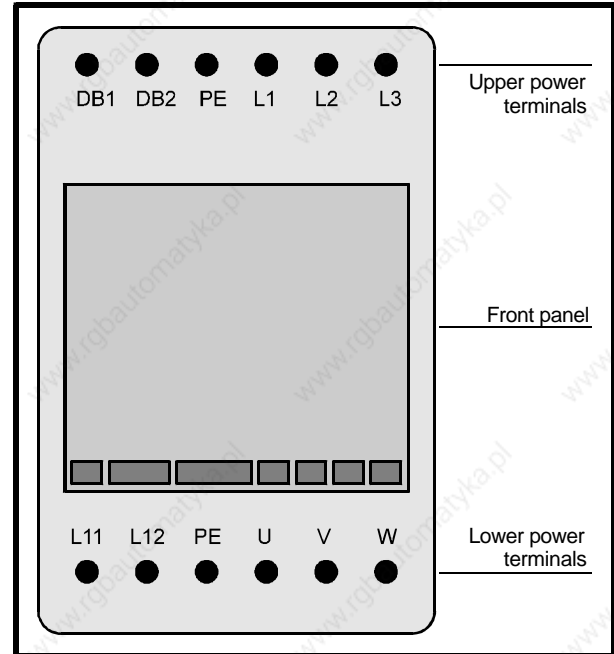
### Power connector

Pin	Function	Type	Notes
U	Phase U	Out	Output to motor
V	Phase V	Out	
W	Phase W	Out	
Y	PE		
L1	Phase L1	In	AC supply connections
L2	Phase L2	In	
L3	Phase L3	In	
-DC	DC bus negative	Out	
BR	External braking resistor	Out	External braking resistor connections
+DC	External braking resistor	Out	+DC bus connection

## DBE1500, DBE2200

Power terminals are located along the top and bottom edges of the front panel.

Maximum tightening torque: 15N.m (132 lb.in)



**Figure 5-3** Locations of the power terminals on models DBE1500 and DBE2200

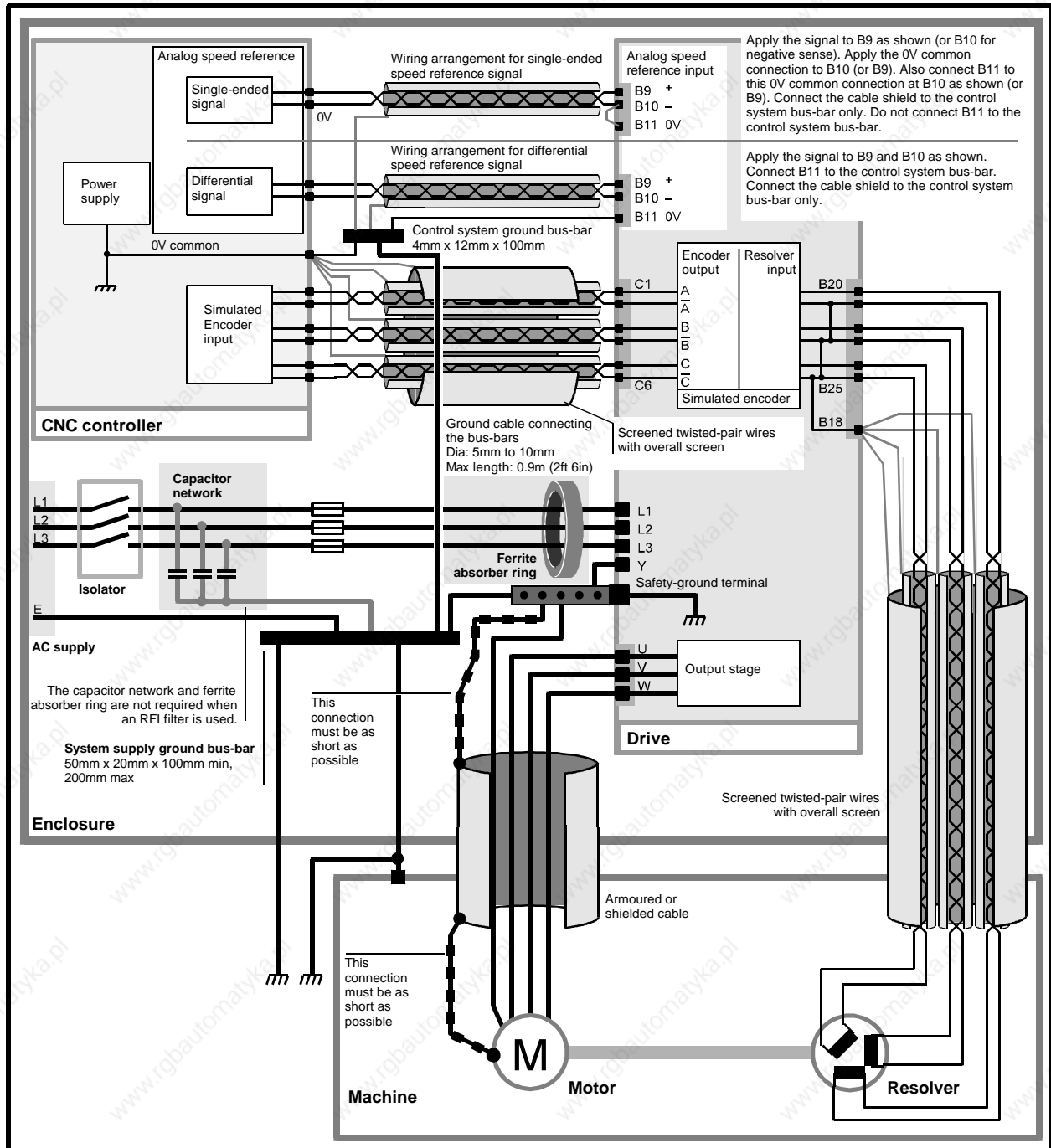
### Upper power terminals

Pin	Function	Type	Notes
DB1	External braking resistor	Out	Braking transistor connection
DB2	External braking resistor	Out	+DC bus connection
PE	Ground		
L1	Phase L1	In	AC supply connections
L2	Phase L2	In	
L3	Phase L3	In	

### Lower power terminals

Pin	Function	Type	Notes
L11	Choke	Out	-DC bus
L12	Choke	Out	
PE	Ground		
U	Phase U	Out	Output to motor
V	Phase V	Out	
W	Phase W	Out	

## 5.3 EMC wiring recommendations

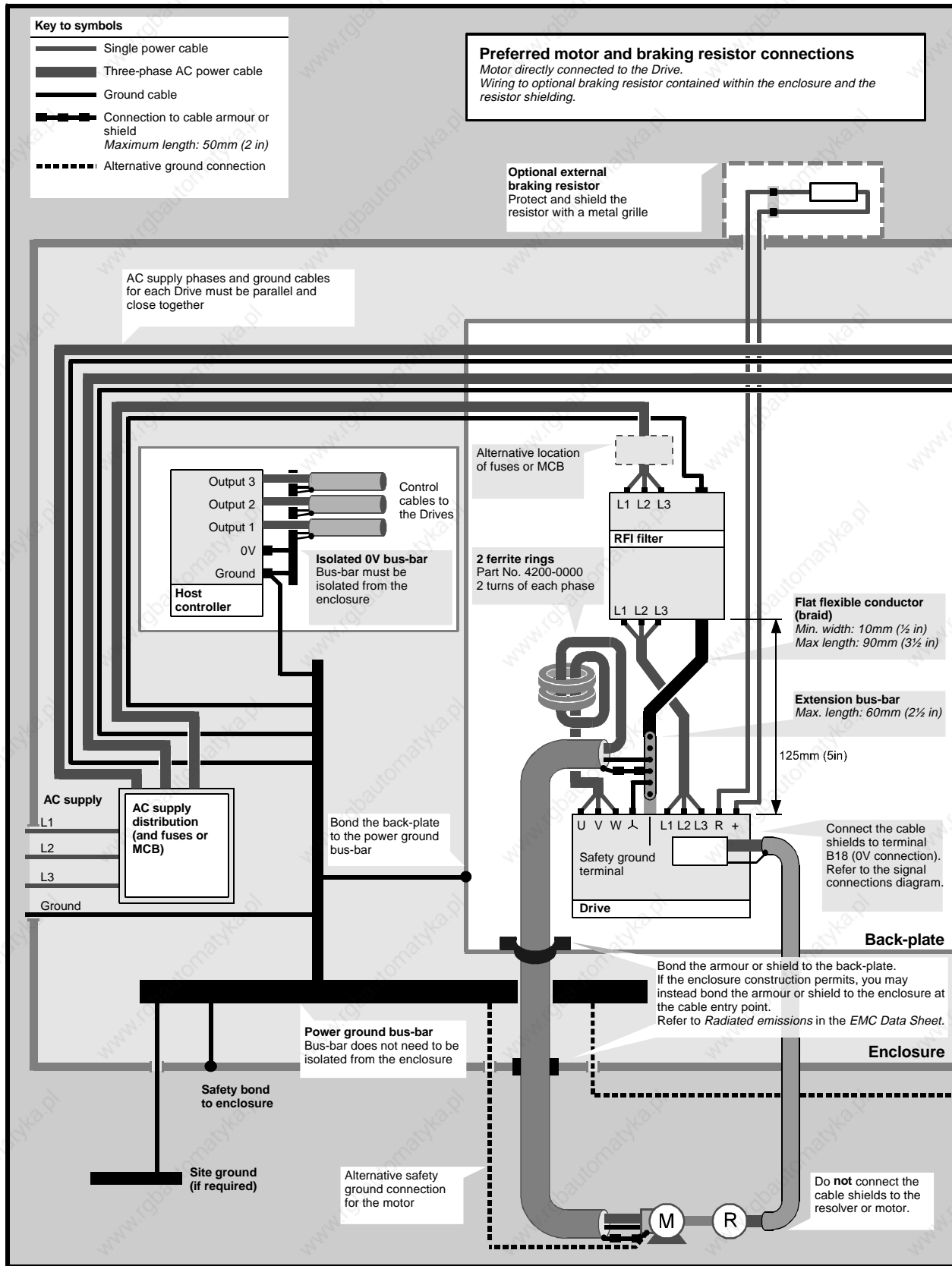


**Figure 5-4** Recommended connections, ground arrangements and other minimum requirements to ensure good noise immunity

### Note

Failure to follow the basic recommendations shown in Figure 5-4 may result in vibration in the motor or spurious trips in the Drive.

Using the arrangement shown in Figure 5-4 does not guarantee that the specified standards for conducted and radiated emissions are met. Additional precautions and guidelines need to be considered. These are shown in Figures 5-5 and 5-6.



**Figure 5-5 Models DBE140 to DBE1100S – Recommended AC power and ground connections**

**Alternative motor and braking resistor connections**

Use these wiring techniques as appropriate for the following:  
 Motor connected to the Drive through a terminal block.  
 Wiring to optional braking resistor external to the enclosure and the resistor shielding.

**Optional external braking resistor**  
 Protect and shield the resistor with a metal grille.  
 Use armoured or shielded cable to connect the braking resistor.

Bond the armour or shield to the back-plate.  
 If the enclosure construction permits, you may instead bond the armour or shield to the enclosure at the cable entry point.  
 Refer to *Radiated emissions* in the EMC Data Sheet.

Alternative location of fuses or MCB

**Example connections using a DIN-rail connector**  
 Bond armour or shields to back-plate using an uninsulated terminal.  
 Bond the DIN-rail to the back-plate.

**2 ferrite rings**  
 Part No. 4200-0000  
 2 turns of each phase

**Flat flexible conductor (braid)**  
 Min. width: 10mm (½ in)  
 Max length: 90mm (3½ in)

125mm (5 in)

**Extension bus-bar**  
 Max. length: 60mm (2½ in)

Alternative safety ground connection for the motor

Connect the cable shields to terminal B18 (0V connection).  
 Refer to the signal connections diagram.

**Back-plate**

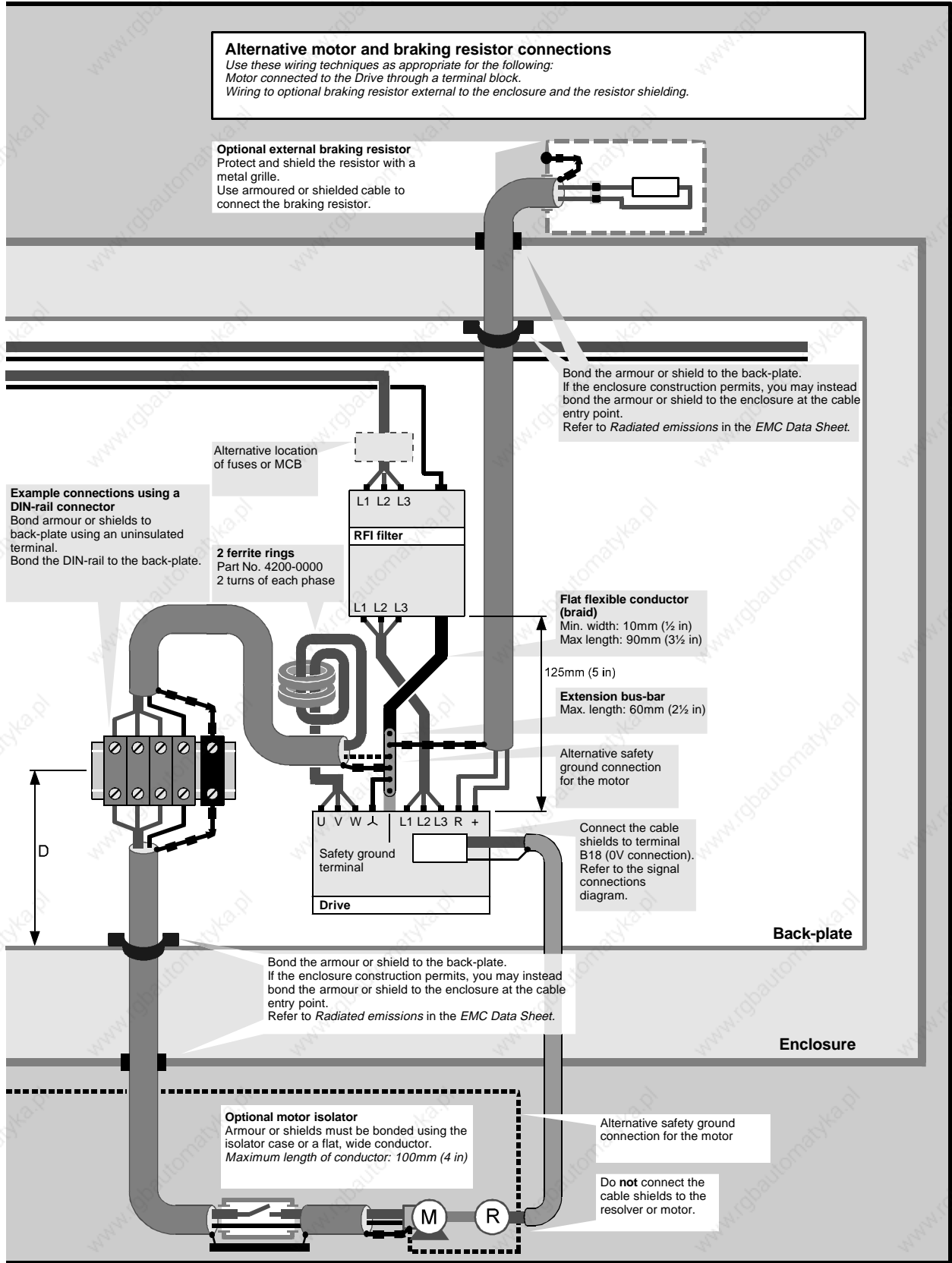
Bond the armour or shield to the back-plate.  
 If the enclosure construction permits, you may instead bond the armour or shield to the enclosure at the cable entry point.  
 Refer to *Radiated emissions* in the EMC Data Sheet.

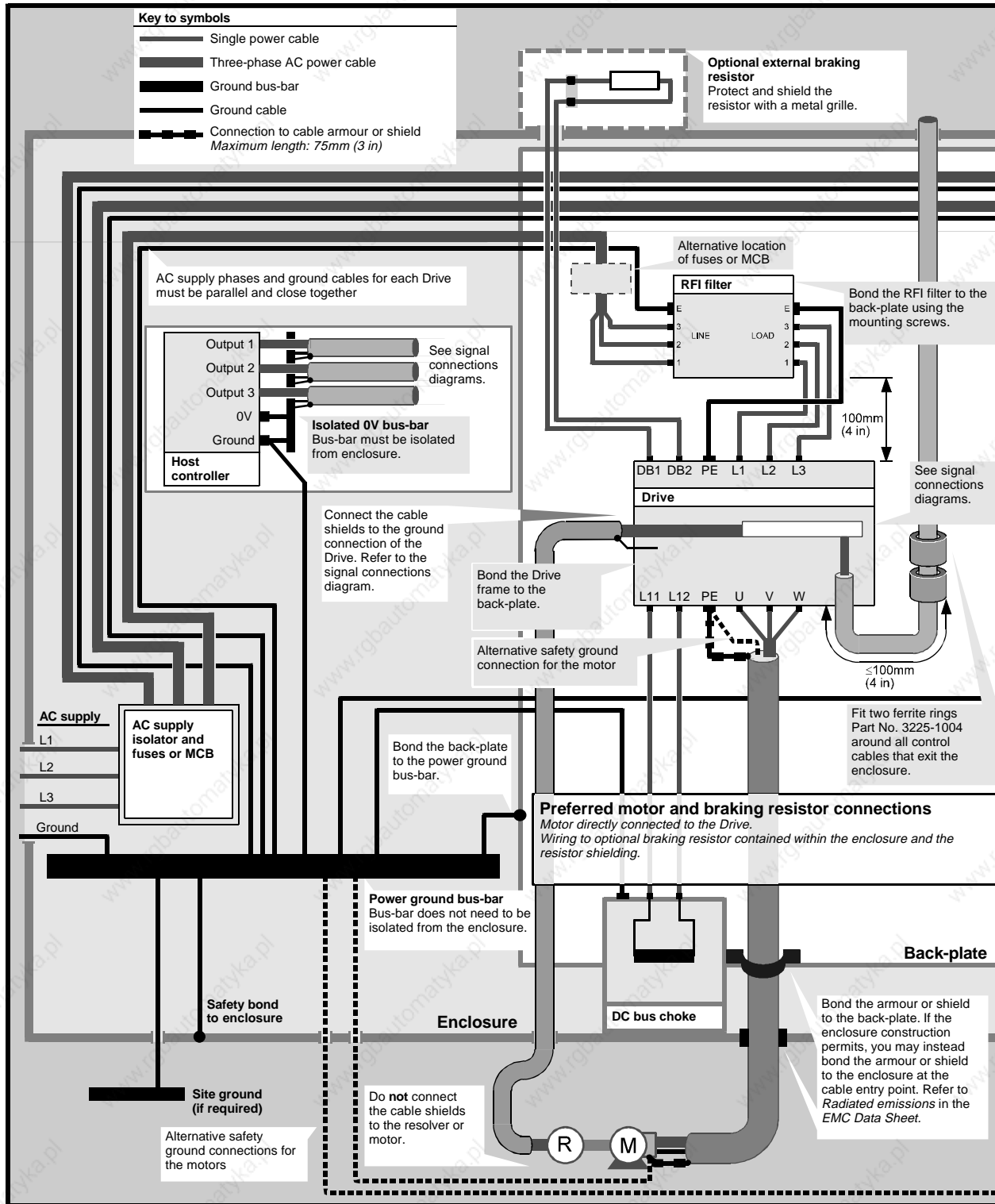
**Enclosure**

**Optional motor isolator**  
 Armour or shields must be bonded using the isolator case or a flat, wide conductor.  
 Maximum length of conductor: 100mm (4 in)

Alternative safety ground connection for the motor

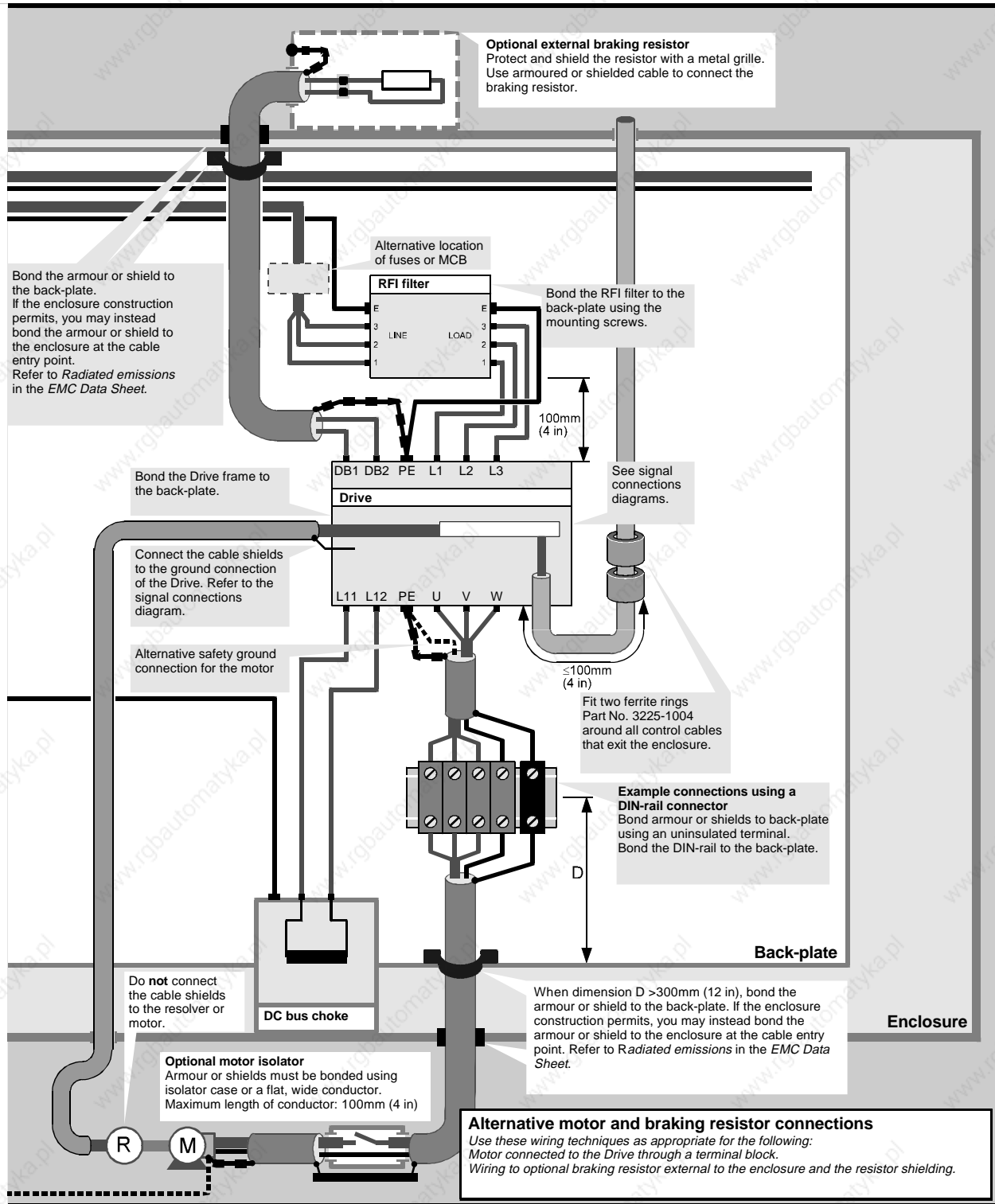
**Do not** connect the cable shields to the resolver or motor.





**Figure 5-6 Models DBE1500 to DBE2200 – Recommended AC power and ground connections**





## 5.4 AC supply cables and fuses



**Warning**

**The AC supply to the Drive must be fitted with suitable protection against overload and short circuits. The table shows recommended fuse ratings. Failure to observe this recommendation will cause a risk of fire.**



**Warning**

**Wiring must be in accordance with local regulations and codes of practice. The table shows typical cable sizes for power input and output wiring. In the event of a conflict, local regulations prevail.**

The following table is only a guide to cable sizes. Refer to local wiring regulations for the correct size of cables.

Model	AC supply cables		Motor cables		Fuse rating A
	mm <sup>2</sup>	AWG	mm <sup>2</sup>	AWG	
DBE140	2.5	14	1.5	16	10
DBE220	2.5	14	1.5	16	10
DBE420	4.0	10	2.5	14	16
DBE600	4.0	10	4.0	10	16
DBE750	4.0	10	4.0	10	20
DBE1100S	4.0	10	4.0	10	30
DBE1500	10	6	10	8	40
DBE2200	16	4	16	6	60

For the following connections, use 600VAC (1000VDC) 3-core pvc-insulated cable with copper conductors of the size specified in the table:

AC power to the Drive

For the following connections, use 600VAC (1000VDC) 3-core pvc-insulated, shielded or armoured cable with copper conductors of the size specified in the table:

Drive to the motor

Drive to external braking resistor (if used)

Cable sizes must be selected for 100% of the RMS currents.

Unusually long cable runs between the Drive and the motor may give rise to spurious tripping due to the effect of cable capacitance. As a result, an over-current fault would be indicated (OC). In this case, output chokes may be required. In difficult cases, consult the supplier of the Drive.

The AC power should be applied through an isolator and a fuse or circuit-breaker of the specified rating. Since a current surge can occur when AC power is applied to the Drive, the use of slow-blow fuses is recommended. As an alternative to fuses, an MCB or MCCB may be used if equipped with adjustable thermal and magnetic trip devices of a suitable rating.

## 5.5 Ground connections

The impedance of the ground circuit must conform to the requirements of Health and Safety Regulations that may apply.

The size of external grounding terminals should be appropriate to the size of the grounding cables.

Ground connections on the power input and power output connectors are connected together in the Drive, enabling the following connections to be made through the Drive:

Motor frame ground to system ground

Motor frame ground to the machine ground

The Drives are suitable for grounded-delta installation without alteration.

## 5.6 DC bus choke

For model size 3, connect the specified DC bus choke to terminals L11 and L12 of the Drive.

An external DC bus choke is not required for model sizes 1 and 2.

## 5.7 Protecting the Drive with line reactors

When a DigitAx is connected to an AC supply which is subject to severe disturbances, as a result of the following for example...

- Capacity is at least 200kVA
- Fault current is at least 5kA
- Power-factor correction equipment is connected close to the Drive
- Large DC Drives having no or ineffective line reactors are connected to the supply
- Direct-on-line started motor(s) are connected to the supply and, when any of

these motors are started, a dip is produced in excess of 20% of the actual supply voltage

... excessive peak current may flow in the input power circuit of the Drive. This may cause nuisance tripping or, in extreme cases, failure of the Drive.

A line reactor should be connected in each phase of the supply to each Drive. Line reactor(s) add the required impedance to the AC supply in order to reduce current transients to a level that can be tolerated by the Drive.



**Caution**

**RFI filters (for EMC purposes) do not give adequate protection against these conditions.**

Three individual reactors, or a single three-phase reactor should be used. Each Drive must have its own reactor(s).

## Typical values

Model	Value (mH)
DBE140	4.1
DBE220	2.8
DBE420	2.5
DBE600	1.7
DBE750	1.4
DBE1100S	0.9
DBE1500	0.7
DBE2200	0.5

## Current ratings

Continuous: Not less than the continuous current rating of the Drive

Peak: Not less than *twice* the continuous current rating of the Drive

## 5.8 Connecting an internal or external braking resistor



**Warning**

### Electric shock risk

**The voltages present on the braking resistor, its associated components and terminals on the Drive are capable of inflicting a severe electric shock and may be lethal.**

## Introduction

When an AC motor is decelerated, energy is returned to the Drive from the motor. When a high inertia load is decelerated in a short time, the energy returned can be too great for the Drive to absorb. The effect is to increase the voltage of the DC bus, with the possibility of the Drive tripping due to overvoltage on the DC bus.

When the DC-bus voltage exceeds a predetermined level (750V), a braking resistor can be connected to the DC bus by an internal transistor in order to absorb the excessive energy. All models except DBE1500 and DBE2200 have an internal braking resistor; this resistor or an external resistor can be used.

The required value of the braking resistor is determined by the maximum required braking torque. The required power rating of the resistor is determined by the amount of energy to be dissipated, duty cycle, repetition time and cooling available for resistor. When the resistor value and power rating have been calculated, a decision can be made to use an external or the internal braking resistor (when fitted).

## Precautions

When the internal or an external braking resistor is used, it is strongly recommended that a **thermal overload protection relay** is fitted in the braking-resistor circuit in order to protect the resistor against overheating. Overheating can damage the resistor and the Drive, as well as increase the risk of fire.

Overheating can be caused by the power-rating of the resistor being inadequate for the application or the internal braking transistor becoming short-circuit.

The maximum DC-bus voltage is 800V. Ensure the (external) braking resistor, connecting cables and insulation are suitable for this operating voltage.

Take the following precautions for external braking resistors:

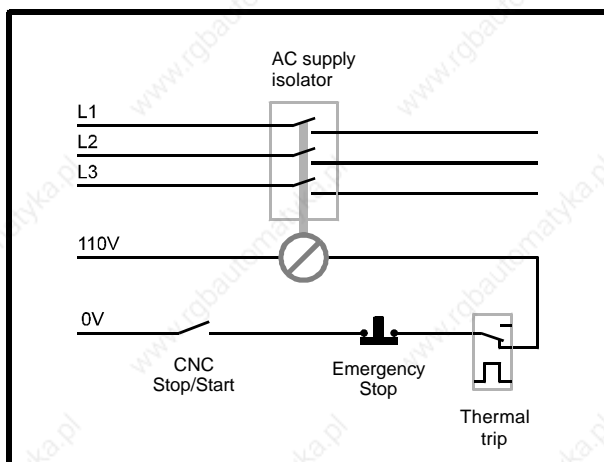
The braking resistor should be capable of tolerating thermal shock; pulse rated resistors are recommended.

Position the braking resistor so that heat dissipated from it cannot affect the Drive.

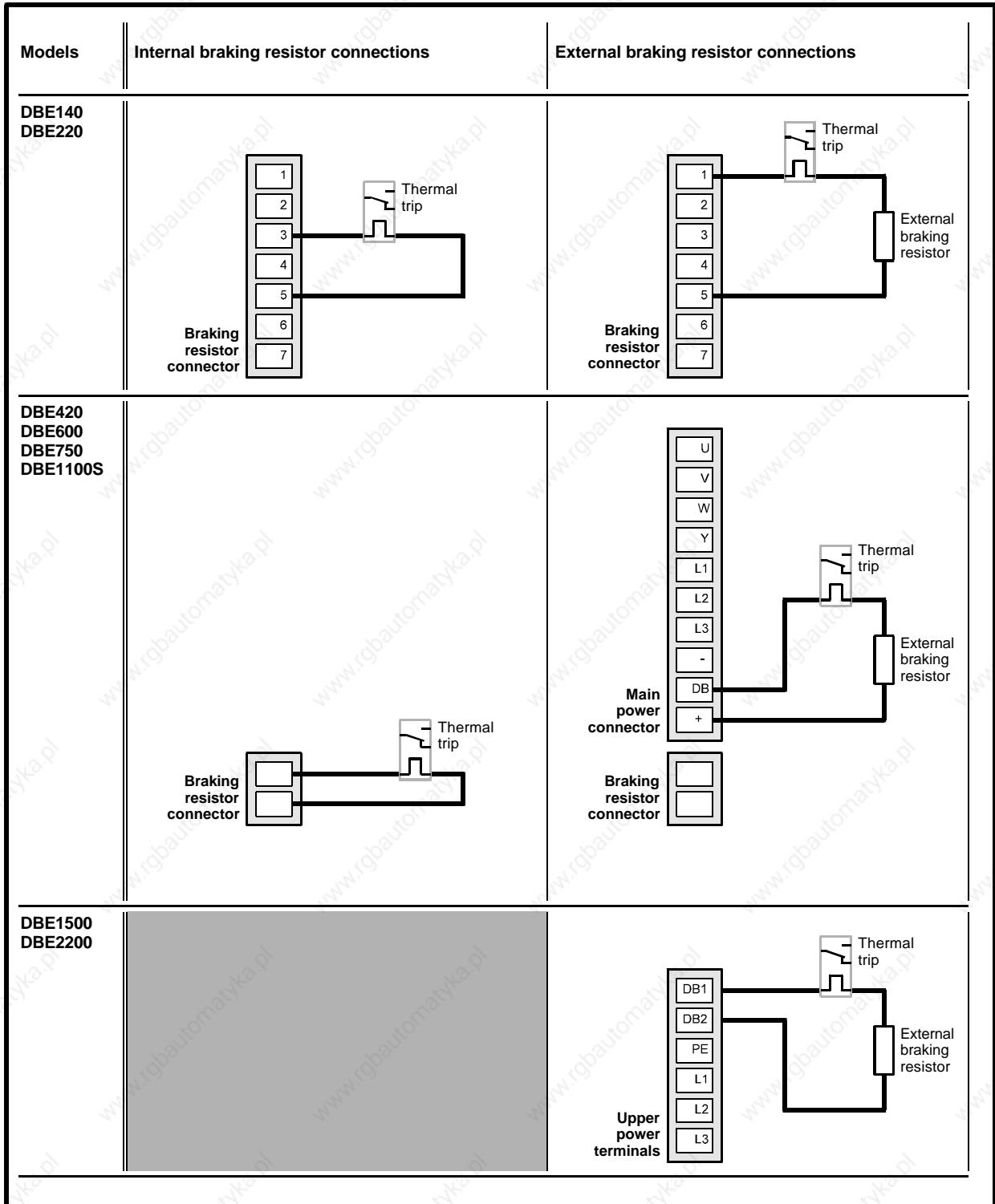
### Thermal-trip circuit for the braking resistor

Connect the thermal overload protection relay to the control circuit of the AC supply isolator, as shown in Figure 5–7. (Do not connect the thermal overload protection relay so that it would disconnect the braking resistor, since interrupting large direct currents will cause arcing.) Connect the thermal overload protection relay to the Drive and braking resistor as shown in Figure 5–8.

A lock-out facility must be included in order to prevent the AC supply from being re-connected to the Drive until the cause of a trip has been fully investigated.



**Figure 5–7** Connecting the thermal overload protection relay to the trip circuit of the AC supply isolator



**Figure 5–8** Connecting internal and external braking resistors to the recommended thermal trip circuit

## 5.9 Example calculations for a braking resistor

The required value and power rating of the braking resistor are calculated from the following:

- Amount of energy to be absorbed
- Rate at which the energy is to be absorbed (power)
- Time lapse between successive decelerations

### Conditions

Drive model: DBE2200  
Drive rating = 22kW  
Peak output current of the Drive ( $I_{pk}$ ) = 72A  
Maximum duration of the peak current = 4 seconds  
Motor rating = 22kW  
Full-load speed of the motor ( $n$ ) = 3000RPM  
Nominal torque rating of motor ( $T_{nom}$ ) = 130Nm  
System inertia ( $J$ ) = 0.5kg.m<sup>2</sup>  
Resistor operating voltage ( $V_R$ ) = 800V  
Motor  $K_T$  = 2.5Nm/ARMS  
Deceleration time from full-load speed to rest ( $t_d$ ) = 2 seconds  
Repeat cycle time = 30 seconds

### Minimum permissible deceleration time

The minimum permissible deceleration time is limited by the following:

- The peak current of the Drive ( $I_{pk}$ )
  - The *intermittent torque limit* of the motor (the value of torque that the motor can deliver for a specified time – see the motor manufacturer's data)
1. Calculate the maximum torque that the motor would produce when the Drive is delivering peak current (72A), as follows:  
$$M_{bDRIVE} = I_{pk} \times K_T = 72 \times 2.5 = 180Nm$$

The Drive would cause this value of torque to be produced for up to 4 seconds.
  2. Refer to the the motor manufacturer's data to obtain the permissible overload for 4 seconds. Then use this figure to calculate the intermittent torque limit for the motor for a 4-second duration. For this example, 3 times the nominal torque rating is assumed, as follows:

$$M_{bINT} = T_{nom} \times 3 = 130 \times 3 = 390Nm$$

3. For calculating the minimum permissible deceleration time ( $t_{bMIN}$ ), use the lower of the two calculated values, as follows:

$$M_{bMAX} = 180Nm$$

4. The following equation is used as the basis for the calculations:

$$M_b = \frac{Jn}{t_b} \times \frac{\pi}{30} (Nm)$$

Use the following derivative of the equation to calculate the minimum permissible deceleration time ( $t_{bMIN}$ ) for stopping the motor from full-load speed:

$$t_{bMIN} = \frac{J\pi n}{30M_{bMAX}}$$
$$t_{bMIN} = \frac{0.5 \times \pi \times 3000}{30 \times 180} = 0.87 \text{ seconds}$$

### Resulting torque

1. Calculate the torque that results from the required deceleration time, as follows:

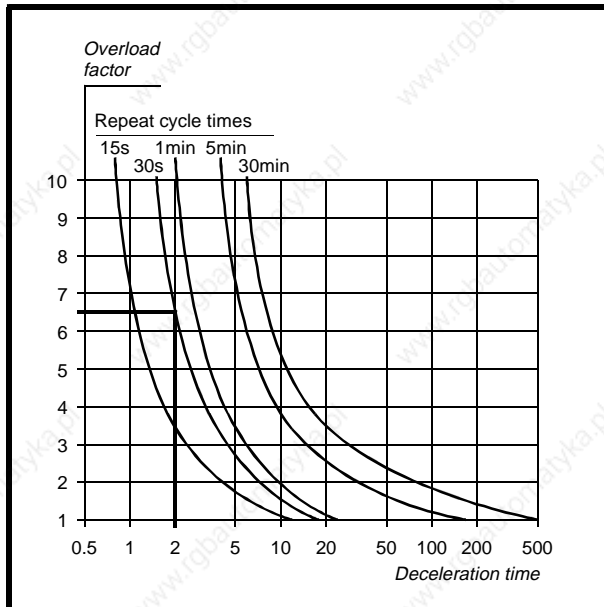
$$M_b = \frac{Jn}{t_b} \times \frac{\pi}{30} (Nm)$$
$$M_b = \frac{0.5 \times \pi \times 3000}{2 \times 30} = 78.5Nm$$

### Power rating of the braking resistor

1. Calculate the power to be dissipated in the resistor during braking as follows:

$$P_b = \frac{M_b \pi n}{30 \times 10^3} (W)$$
$$P_b = \frac{78.5 \times \pi \times 3000}{30 \times 10^3} = 24.7kW$$

2. Since braking is planned to occur intermittently, the resistor can be rated for *intermittent* rather than *continuous* power dissipation so that the overload factor of the resistor can be used. This factor can be obtained from cooling curves for the resistor, as shown in Figure 5–9.



**Figure 5-9 Example cooling curves for power resistors (in practice, refer to the cooling curves for the resistor to be used)**

- The cooling curves indicate that for a braking time of 2 seconds and repeat cycle time of 30 seconds, the overload factor (F) is 6.5.
- Calculate the required power rating of the resistor, as follows:

$$P_R = \frac{P_b}{F} = \frac{24.7}{6.5} = 3.8\text{kW}$$

### Value of the braking resistor

- Calculate the maximum suitable value for the braking resistor, as follows:

$$R_{MAX} = \frac{(V_R)^2}{P_b} = \frac{800^2}{24.7 \times 10^3} = 25.9\Omega$$

- In practice, use a resistor having a preferred value close to and lower than the calculated value. This is because the calculated value would cause the braking transistor to be switched on almost continuously during braking. In this case, the Drive will not have full control of the DC-bus voltage. A lower value of braking resistor will cause the braking transistor to act as a chopper which will then allow the Drive to control the DC-bus voltage more accurately.

The reduction in value does not increase the power dissipation since the average voltage across the resistor is reduced by the braking transistor operating as a chopper.

For this example:  $R = 22\Omega$

- Refer to the following table to find out if the internal braking resistor (when fitted) is suitable for the application. If it is not, an external resistor must be used. In this case, ensure the resistor value is not less than the minimum permissible value.

Model	Internal resistor		External resistor
	Value	Power ratings	Minimum permissible value
DBE140 DBE220	80Ω	150W continuous 1.5kW for 10 secs braking time with 90 secs minimum cooling time.	65Ω
DBE420 DBE600 DBE750 DBE1100S	40Ω	300W continuous 3.0kW for 10 secs braking time with 90 secs minimum cooling time.	27Ω
DBE1500 DBE2200			11Ω

### Current setting for the thermal overload relay

- Calculate the maximum permissible continuous current through the braking resistor, as follows:

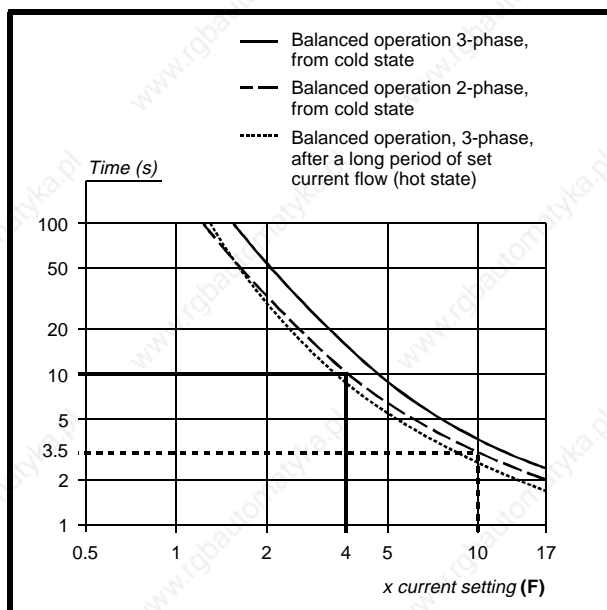
$$I_{Rmax} = \sqrt{\frac{P_R}{R}} = \sqrt{\frac{3.8 \times 10^3}{22}} = 13.1\text{A}$$

where:

$P_R$  is the power rating of the resistor to be used (not the calculated power dissipation)

$R$  is the actual value of the braking resistor (not the calculated value)

- Use the *tripping curves* for the thermal overload relay in order to find the overload factor (F) that will cause the relay to trip after 10 seconds. See Figure 5-10.



**Figure 5-10 Example tripping curves for the Telemecanique thermal overload relays type LR2-Dx3xx**

3. Calculate the current setting required for the thermal overload relay, as follows:

$$I_{\text{SET}} = \frac{I_{\text{Rmax}}}{F} = \frac{13.1}{4} = 3.275\text{A}$$

4. Select a model of thermal overload relay that can be set at 3.275A (eg. Telemecanique LR2-D1308).
5. Calculate the maximum current that could flow through the resistor (eg. due to the braking transistor becoming short-circuit), as follows:

$$I_{\text{Rpk}} = \frac{V_{\text{R}}}{R} = \frac{800}{22} = 36\text{A}$$

6. Calculate the overload factor for this condition, as follows:

$$F_{\text{S/C}} = \frac{I_{\text{Rpk}}}{I_{\text{SET}}} = \frac{36}{3.275} = 11$$

7. Use the tripping curves to find the time that the thermal overload relay will take to trip (eg. 3.5 seconds approximately)
8. Check that the braking resistor can tolerate the overload current for this duration.

## 5.10 Control Keypad connections

### Model size 3

Use screened cable when connecting to a remotely mounted Control Keypad. Connect the cable screen to an external ground terminal which should be as close to the Control Keypad as possible.

The connecting cable should be shielded data cable having a maximum length of 100m (330ft). For lengths of less than 1 metre (3 feet), unshielded twisted-pair wiring may be used. The Control Keypad connector is a 9-pin D-type socket.

### Model sizes 1 and 2

The Control Keypad cannot be mounted remotely.



## 5.11 Signal connections

### Note

In the connection diagrams, the programmable inputs and outputs are shown in their default configurations.

### CON B – Resolver connections

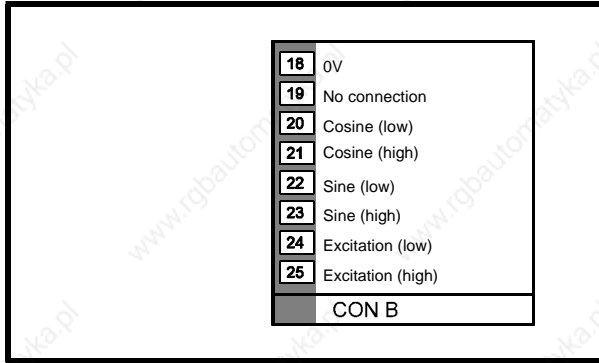


Figure 5–11 Resolver connections

Pin	Function	Type	Description
B18	0V		Ground connection for the resolver wiring screen
B19	Not internally connected		Do not connect
B20	Cosine low	In	Cosine signal from resolver
B21	Cosine high	In	
B22	Sine low	In	Sine signal from resolver
B23	Sine high	In	
B24	Excitation low	Out	
B25	Excitation high	Out	Signal at 7.812 kHz for resolver

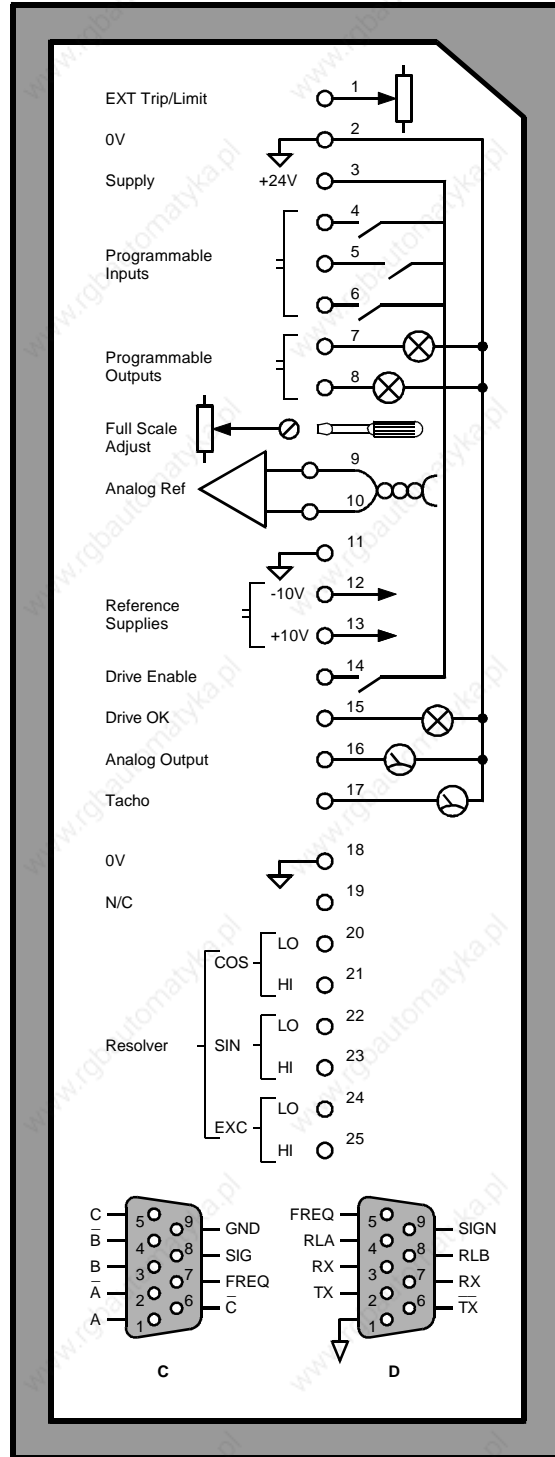
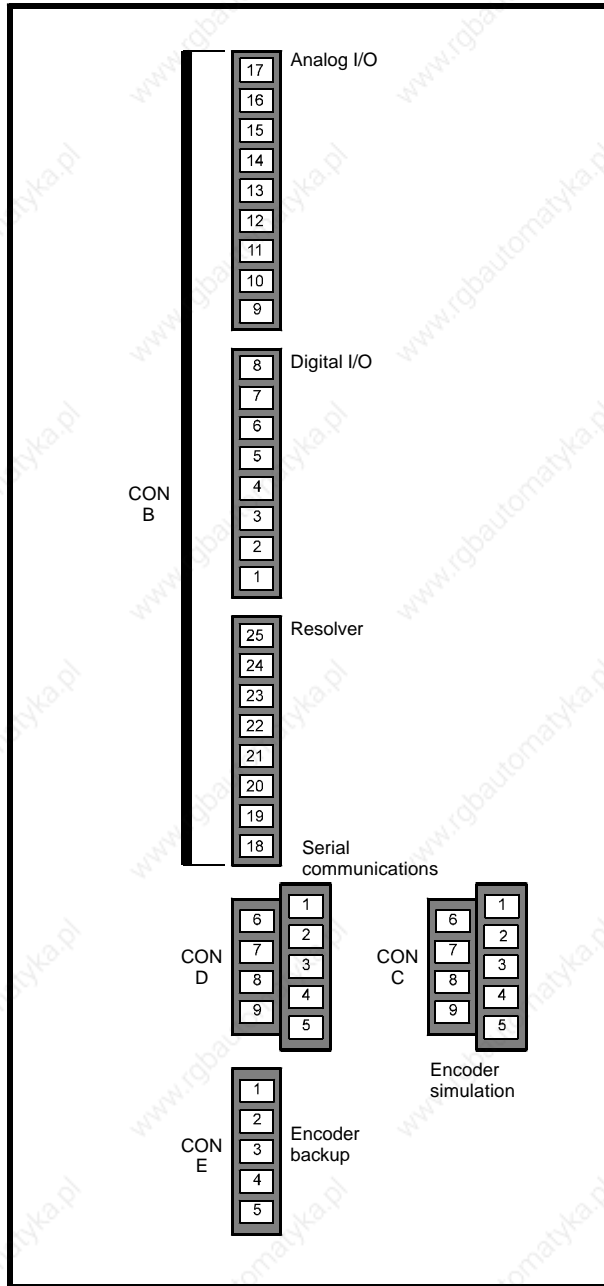
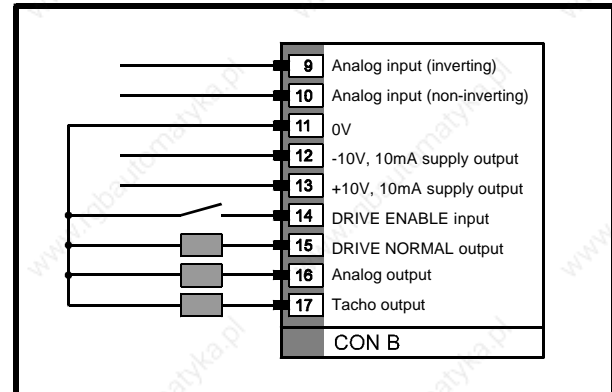


Figure 5–12 DBE140 to DBE1100S Legend printed on the front panel showing the locations of the control signal connectors



**Figure 5-13 DBE1500, DBE2200 Layout of the control signal connectors on the front panel**

## CON B – Analog I/O connections



**Figure 5-14 Analog inputs and outputs**

### Analog inputs

Input impedance: 10k $\Omega$

### Analog outputs

Output impedance: 1k $\Omega$

Pin	Function	Type	Description
B9	Analog inverting input	In	When b6 = 0, these inputs are used as analog speed reference
B10	Analog non-inverting input	In	When b6 = 1, these inputs are used as torque reference input Input Impedance: 10k $\Omega$
B11	0V		Control signal common
B12	-10V (10mA)	Out	Voltage reference
B13	+10V (10mA)	Out	Voltage reference
B14	Drive enable	In	Apply +6V to +24V to pin B14, and setting parameter b2 at 1, to enable the Drive.
B15	Drive Normal	Out	Logic output to indicate the Drive is operating normally. Normal state is indicated by: +24V output on B15 b33 = 1
B16	Programmable analog output	Out	Refer to b12 and b13
B17	Tacho-generator output	Out	Accuracy: $\pm 15\%$ When Pr99 $\leq 3000$ RPM 3V = 1000 RPM When Pr99 > 3000 RPM 3V = 4000 RPM This output must be loaded by 10k $\Omega$ in order to produce a load current of 1mA

## CON B – Digital I/O connections

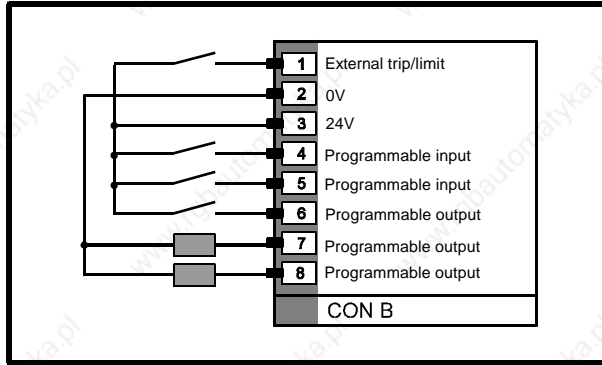


Figure 5–15 Digital I/O connections

### Digital inputs

Input impedance: 15kΩ

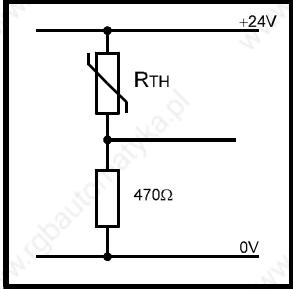
Logic 0 = <4.5V or input open circuit

Logic 1 = >5.5V

### Digital outputs

Output type: Open collector (PNP)

Current: 60mA per channel

Pin	Function	Type	Description
B1	External trip / External current limit	In	<p>When parameter b56 is set at 0, a signal applied to this input sets the current-trip level.</p> <p>When parameter b56 is set at 1, this input is used as an external trip input. For example, the input can be connected to a PTC motor thermistor as shown below.</p>  <p>Note — The 470Ω resistor value shown applies to <b>Dutymax</b> servomotors. For other motors, the resistor value should be selected so that the input signal at terminal B1 is less than 5V at the motor trip temperature.</p>
B2	0V		Control signal common
B3	+24V, 100mA	Out	Power supply to external control circuits
B4	Programmable input 2	In	When parameter b16 = 0, and Pr21 = 2, these inputs are used for digital speed selection. The configuration can be read in parameter Pr18.
B5	Programmable input 1	In	When b16 = 1, these inputs are used for limit switch signals.

B4	B5	When b16 = 0, b15 = 0 Selects digital speed reference parameter...	When b16 = 0, b15 = 1 Position offset control	When b16 = 1 Limit-switch inputs
Open-cct	Open-cct	Pr0	No effect	Inhibits rotation in both directions
Open-cct	+24V	Pr1	Pr20 subtracted from buffer every 5ms	Inhibits reverse (anti-clockwise) rotation
+24V	Open-cct	Pr2	Pr20 added to buffer every 5ms	Inhibits forward (clockwise) rotation
+24V	+24V	Pr3	Pr3No effect	Allows rotation in either direction

Pin	Function	Type	Description
B6	Programmable input 0	In	The function of this input is selected using b18, b53 and Pr27 as follows:  Zero speed Hold Shaft orientation input.

b18	Signal applied to B6	Function
0	logic 0	Not stop
1	X	Stop
X	logic 1	Stop

Pin	Function	Type	Description
B7	Programmable output 1	Out	Refer to Pr30
B8	Programmable output 0	Out	Refer to Pr31

## CON C – Simulated Encoder connector

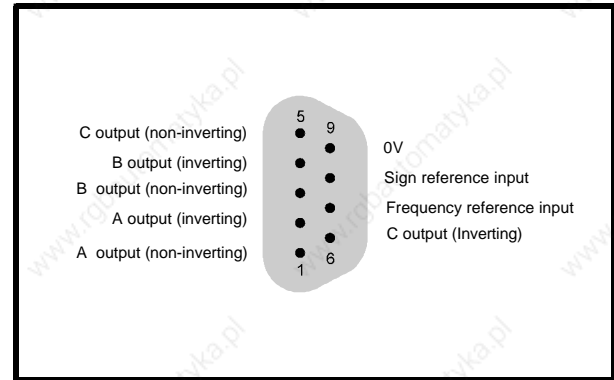


Figure 5–16 Simulated Encoder connections

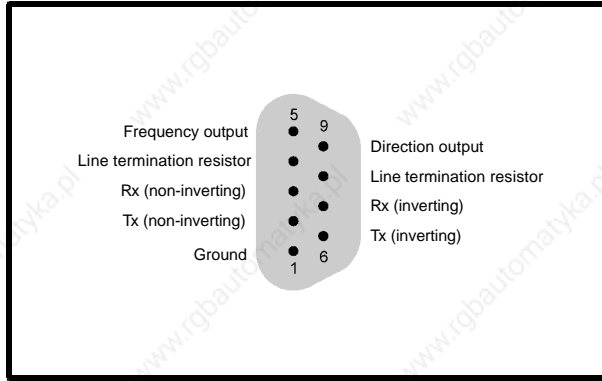
### Frequency/Sign inputs

Input impedance: 1.5K $\Omega$

Pin	Function	Type	Description
C1	A	Out	Simulated encoder, channel A non-inverting output
C2	$\bar{A}$	Out	Simulated encoder, channel A inverting output
C3	B	Out	Simulated encoder, channel B non-inverting output
C4	$\bar{B}$	Out	Simulated encoder, channel B inverting output
C5	C	Out	Simulated encoder, channel C non-inverting output
C6	$\bar{C}$	Out	Simulated encoder, channel C inverting output
C7	Frequency reference input	In	When parameters b14 = 0 and b17 = 0, the frequency of a signal applied to this input controls the motor speed.  <b>Scaling</b> When Pr99 is set at $\leq 3000$ RPM, 409.6kHz gives 3000 RPM. When Pr99 is set at $> 3000$ RPM, 409.6kHz gives 6000 RPM. Reliable operation at 409.6kHz occurs when the amplitude of the input pulse train is between 15V and 24V.
C8	Sign reference input	In	Used in conjunction with terminal C7 to indicate the required direction of rotation of the motor (See parameter b15).  Apply 0V for reverse rotation (anti clockwise)  Apply +15V (or leave open-circuit) for forward rotation (clockwise)
C9	0V		

## CON D – Serial Communications connector

The serial communications connector is a 9-way D-type. Full duplex RS485 connections require two screened twisted-pair wiring.



**Figure 5-17 Serial Communications connections**

Pin	Function	Type	Description
D1	GND		0V
D2	TX	out	Transmit signal, non-inverted
D3	RX	in	Receive signal, non-inverted
D4	RLA		Network termination resistor
D5	FREQOUT	out	Frequency output (102.4kHz = 6000rpm)
D6	$\overline{\text{TX}}$	out	Transmit signal, inverted
D7	$\overline{\text{RX}}$	in	Receive signal, inverted
D8	RLB		Network termination resistor
D9	DIROUT	out	Direction output An external 10k $\Omega$ load resistor connected to +10V is required +15V indicates forward direction (clockwise) 0V indicates reverse direction (anti clockwise)

## CON E – Back-up Supply connector

For applications that require serial communications or information on rotor shaft position to be maintained when AC power is lost from the Drive, an external power supply can be connected to connector E which is on the underside of the Drive on sizes 1 and 2, and at the right hand side of the control board in size 3. This is used to maintain the supplies to the control circuits in the Drive.

When AC power is lost, the display on the Drive shows the decimal point moving from left to right. When AC power returns, the Drive goes through the normal calibration routine.

Pin	Supply
1	+8V
2	+24V
3	0V
4	-24V
5	0V



## 6 Control Keypad

Two types of Control Keypad are used in DigitAx Drives. The type used depends on the model size.

The Control Keypad can be removed from model size 3.

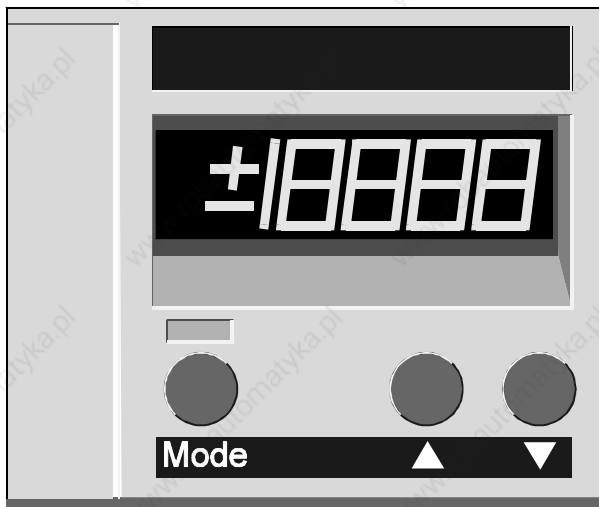
### 6.1 DBE140, DBE220, DBE420, DBE600, DBE750, DBE1100S



**Caution**

**Model sizes 1 and 2 only – Before removing the Control Keypad, disconnect the Drive from the AC supply.**

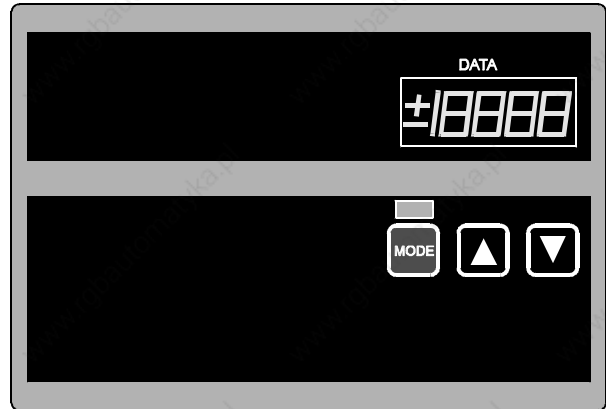
The Control Keypad on these models has a programmable non-volatile memory. When power is removed, the Control Keypad retains any stored parameter settings. This allows a programmed Control Keypad to be transferred to another Drive (enabling a Drive to be replaced without the necessity for re-programming).



**Figure 6-1 Control Keypad used in models DBE140, DBE220, DBE420, DBE600, DBE750, DBE1100S**

### 6.2 DBE1500, DBE2200

The Control Keypad on these models has no memory; the parameters are stored in the non-volatile memory on the control board. Programs cannot be transferred from one Drive to another by swapping the pods.



**Figure 6-2 Control Keypad used in models DBE1500, DBE2200**

## 6.3 Display and controls

### Digital display

A 4½ digit display is used to show the following:

- Status of the Drive
- Selected parameter
- Value of the selected parameter

At the time AC power is applied, the display shows the following in sequence:

- Software version number
- CAL** during calibration
- rdY** to indicate that the Drive is ready

When the Drive is running, the display shows the motor speed in rpm.

When a trip has occurred, the display shows a related trip code (see Chapter 12 *Diagnostics*).

### Keypad

The Control Keypad has three keys. These are as follows:

#### Mode key

The **Mode** key is used to change the type of information shown on the display. A green LED indicator responds to operation of the **Mode** key.

#### Arrow keys

These are used to scroll through the parameter list, and edit the parameter values shown on the digital display.





## 7 Parameters

There are two types of parameters

- Variable parameters, denoted by **Prxx**
- Bit parameters denoted by **bx**

Variable parameters allow numerical values to be entered. Bit parameters allow digital settings to be made.

Both types of parameter can be as follows:

- Read–write (R–W)
- Read-only (RO)

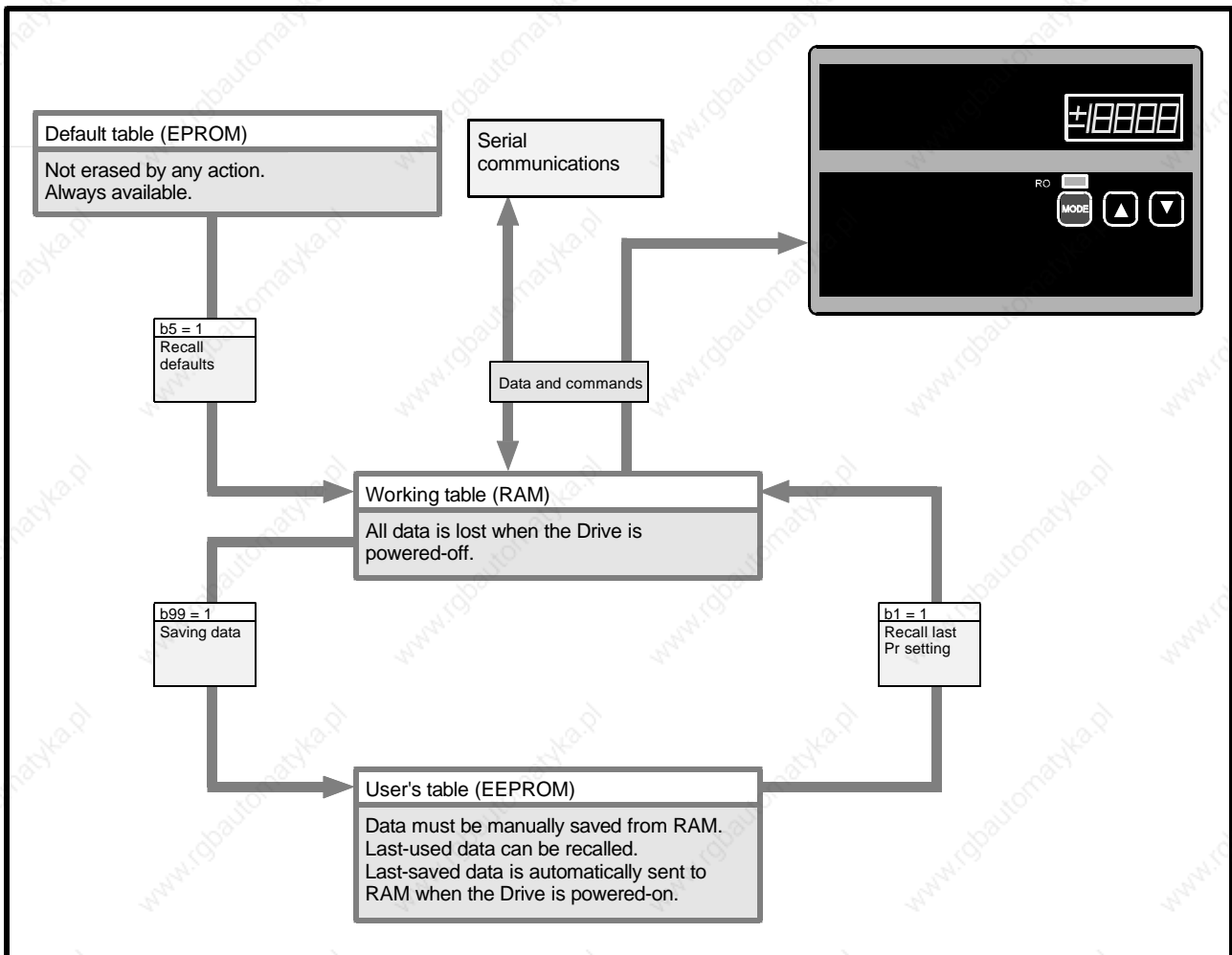
Read–write parameters are programmable by the user, and the values can be read on the display (or remotely using a serial communications link).

Read-only parameters are for information purposes; they cannot be programmed.

## Default values

The read–write parameters are programmed during manufacture with default values which are generally valid for the size of Drive and motor.

The default values cannot be erased or changed by the user.



**Figure 7–1** How parameter values are stored and changed

## Memory Tables

Parameters are held in three Memory Tables (see Figure 7–1). A **Default Table** contains the permanent default settings for the parameters, a **Working Table** holds values that are in use while the Drive is operating, and a **User's Table** holds values set and saved by the user.

Default parameters are all recalled to the Working Table by setting bit parameter **b5** at **1**.

The Default Table is held in PROM in the Drive. The Working Table is held in RAM in the Drive and the User's Table is held in EEPROM in the Control Keypad. This arrangement ensures that a Drive is always equipped with its default values, and the user-defined parameter values remain unchanged when the Control Keypad is removed from the Drive.

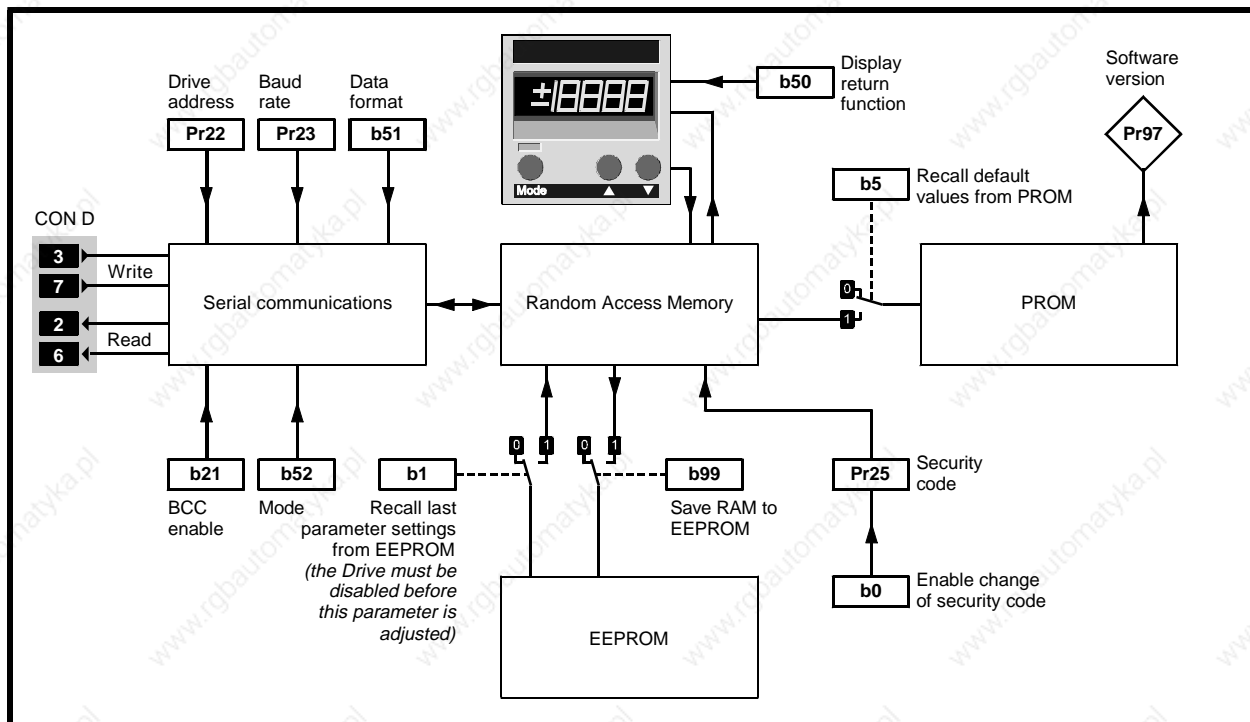
### Note

**Setting parameters to their default values includes the value of the security code parameter Pr25. The default value is zero, which allows any parameter to be changed; ie. security is lost when default values are recalled.**

At the time AC power is applied, the contents of the User's Table are read into the Working Table. If the Drive has not been programmed by the user, the User's Table contains the default values.

When a parameter value is changed, the new value is held in the Working Table until AC power is removed. The original value is stored in the User's Table and can be recalled by setting bit parameter **b1** at **1**. This is useful when experimenting with different values for a parameter when setting up a Drive.

Saving parameter values held in the Working Table stores them in the User's Table. Saving is carried out by setting **b99** at **1**. The contents of the Working Table are lost when AC power is removed.



**Figure 7–2 Logic diagram showing how parameter values are changed using serial communications**

---

## 8 Programming Instructions

---

### 8.1 Displaying a parameter

Use the following procedure to display a parameter and its value:

1. Press the **Mode** key once. The LED above the **Mode** key illuminates. The display will alternately display the number of the last accessed parameter in the form of **Pr33** or **b17** and the parameter value. After 8 seconds, the display returns to showing the current status.
2. To select a different parameter from the one shown, either hold down or press repeatedly one of the arrow keys. The display scrolls through the parameter numbers.
3. Release the key when the number of the required parameter is displayed.
4. Press the **Mode** key. The display shows the value of the parameter; the value remains on display for 8 seconds after a key is last pressed.

### 8.2 Changing a parameter value

#### Note

**If a new value has been entered in security parameter Pr25, parameter values cannot be edited unless the correct value is first entered in Pr25. Refer to Chapter 9 Security.**

---

The values of parameters can be changed when the Drive is stopped or running.

1. Select the parameter to be edited by following the instructions above in *Displaying a parameter*.
2. When the value of the parameter is being displayed hold down or press repeatedly one of the arrow keys to change the displayed value.
3. To enter the value, press the **Mode** key. The LED extinguishes.

### 8.3 Saving parameter values

Parameters are not saved when AC power is removed. Use the following procedure to save parameters:

1. Follow the procedure in *Displaying a parameter* to display the value of parameter **b99**.
2. Follow the procedure in *Changing a parameter value* to set the value at **1**.

The current parameter values are now saved in the User's Table.



---

## 9 Security

---

### 9.1 Setting up a security code

The Drive is supplied with no security set up (ie. security code = 0). There is no protection against unauthorized or accidental editing of parameters. Use the following procedure to set up a security code:

1. Set **b0** to 1
2. Set **Pr25** to the required security code number. (From 0 to 9999)
3. Set **b99** to 1 to save the new security code

At this stage, the security code is set but only in the User's Table. To make the new security code active, remove AC power for at least 5 seconds.

### 9.2 Security access

To edit parameters when a security code is in use, proceed as follows:

1. Set **Pr25** to the User Security Code number.
2. Read/Write parameters can now be edited.

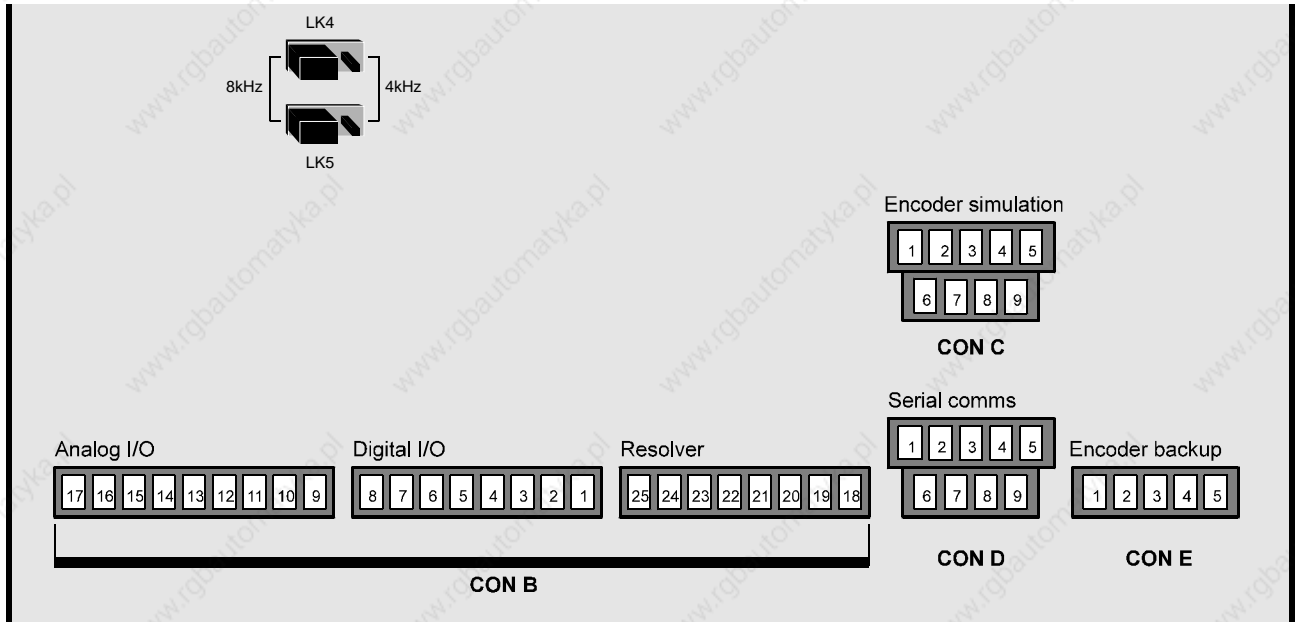
### 9.3 Changing a security code

1. Set **Pr25** to the existing User Security Code number
2. Follow the procedure in *Setting up a security code*.



## 10 Getting Started

### 10.1 Setting jumpers



**Figure 10–1** Approximate locations of the jumpers on the SD200 board

#### Models DBE1500 and DBE2200

If required, and prior to operation of the Drive, change the settings of LK4 and LK5 on the SD200 board to set the switching frequency of the IGBT output bridge at 4kHz.

Default setting: 8kHz

The approximate locations of the jumpers are shown in Figure 10–1, which shows the default settings.

### 10.2 Setting parameter values



**Caution**

**Take care when adjusting parameters, especially the protection parameters. Incorrect values may result in damage to the motor.**

For the Drive to operate correctly with a motor, appropriate values must be given to certain parameters. Follow the instructions in this chapter to enter values for these parameters in order to get the motor and Drive running. Adjustments can be made later to optimize the system.

The following parameters may be left initially in their default state:

Speed reference	Analog $\pm 10V$ (b17 = 0)
Acceleration and deceleration ramps	Disabled (b7 = 0)
Software enable	Enabled (b2 = 1)
Limit-switch	Disabled (b16 = 0V)
Analog output B16	Indicates clamped current demand (b12 = 0, b13 = 0)
Analog output B17	Indicates simulated tachogenerator signal
Digital output B7	Configured for I <sup>2</sup> t limitation (Pr30 = 0)
Digital output B8	Configured for temperature pre-alarm (Pr31 = 1)
PID parameters Pr13, Pr14, Pr15	Set at typical values

## Pr95 — Number of motor poles

Enter 4, 6 or 8 in **Pr95** according to the construction of the motor. (Default setting: 6)

If this parameter is changed, the following procedure must be performed to make the change take effect:

- Save the parameters (**b99** = 1)
- Switch off the drive, and wait 10 seconds
- Switch on the drive

## 10.3 Protection parameters

### Pr42 — Maximum current

Since servo applications require rapid acceleration to a high speed, the motor must tolerate a short-term current  $I_{max}$  in excess of the continuous full load current,  $I_{nom}$ .  $I_{max}$  may be lower than the rated maximum current of the Drive,  $I_{pk}$ . **Pr42** is used to limit the maximum current delivered by the Drive so that  $I_{max}$  for the motor is not exceeded.

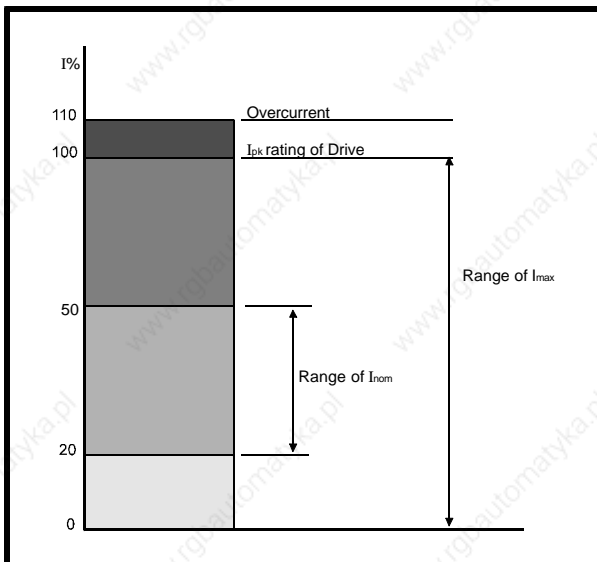
Calculate the following:

$$\text{Pr42} = \frac{I_{max}}{I_{pk}} \times 100$$

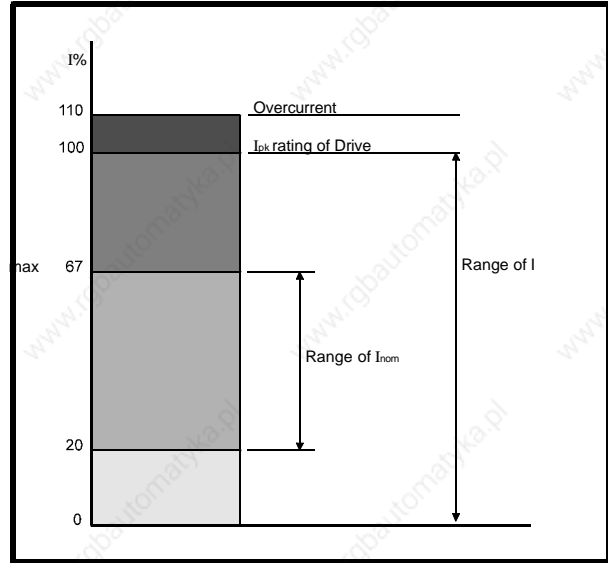
where:

$I_{pk}$  = Rated current of the Drive  
 $I_{max}$  = Maximum motor current

Enter this calculated value in **Pr42**.



**Figure 10-2 Models DBE140, DBE220, DBE420, DBE600, DBE750 — Relationship between maximum current (Pr42) and nominal current (Pr45)**



**Figure 10-3 Models DBE1100S, DBE1500, DBE2200 — Relationship between maximum current (Pr42) and nominal current (Pr45)**

The default value of **Pr42** is 100, which makes  $I_{max}$  equal to  $I_{pk}$ .

Example: if the rated current  $I_{pk}$  of the Drive is 24.0A and the required maximum motor current  $I_{max}$  is 19A, then:

$$\text{Pr42} = \frac{19}{24} \times 100 = 79.17\%$$

Since a whole number must be entered in **Pr42**, the value entered in this example would be 79 or 80.

### Maximum continuous current

This is the maximum current level that can flow in the motor continuously without causing overheating and any permanent damage to the motor. This value is entered **Pr45**, and is calculated as the percentage of  $I_{pk}$ .

The motor in the above example is rated for 9A continuously.

$$\text{Pr45} = \frac{9}{24} * 100 = 37.5\%$$

Since a whole number must be entered in **Pr45**, the value entered in this example would be 37 or 38.



## Pr80 — I<sup>2</sup>t protection

The effect of the values of **Pr42** and **Pr45** on the operation of the Drive are important. When the motor current exceeds the value of  $I_{nom}$  (**Pr45**) the Drive will start integrating the current with respect to time constant in **Pr55**. This integrated value is displayed in **Pr80**. The Drive limits the current when **Pr80** reaches 100%. The Drive **does not trip** when this point is reached. The display shows **It**, and the current is limited to the level set in **Pr45**.

When the motor current reduces to below the value set in **Pr45**, the integrator starts to count down towards 0. This allows for short periods of high over-load to be tolerated, particularly during acceleration and deceleration cycles.

Current in excess of 110% of  $I_{pk}$  (which would indicate an abnormal condition such as a short-circuit or a ground fault in the motor circuit) activates a hardware trip circuit. This produces over-current trip **OC**, and discontinues the current in the motor.

### Analysis of the effective current

When the specifications of the mechanical system and of the duty cycle are known, it is possible to evaluate the effective current  $I_{eff}$  to verify whether it exceeds  $I_{nom}$  at any part of the cycle. It is possible then to calculate the amount of time spent in the overload region during a particular cycle, and determine when possible [x t] limiting will occur.

Using the example operating cycle shown below:

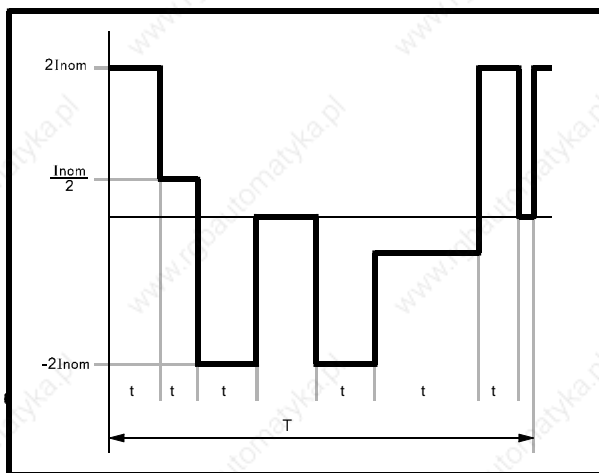


Figure 10-4 Example operating cycle

The effective current is given by:

$$I_{eff} = \sqrt{\frac{I_1^2 t_1 + I_2^2 t_2 + \dots + I_6^2 t_6}{T}}$$

where  $I_1$  to  $I_6$  are the current levels during time periods  $t_1$  to  $t_6$ .

To ensure that short-term overload does not cause the **I<sup>2</sup>t** integration to time out, the calculated value of  $I_{eff}$  must not exceed the value of  $I_{nom}$ .

## 10.4 PID parameters

The default values of the dynamic parameters (PID) are valid for typical spindle applications. It is recommended that the PID functions should not be disturbed until the Drive is commissioned and its behaviour during a normal duty cycle has been observed. The PID parameters are as follows:

Parameter	Default value	Function
Pr13	30	Proportional gain Range 0 to 255 Resolution 1
Pr14	30	Derivative gain Range 0 to 128 Resolution 1
Pr15	30	Integral gain Range 0 to 255 Resolution 1
Pr7	1	Speed loop bandwidth limit. Range 1 to 7 (320Hz to 5Hz)

## 10.5 Speed calibration

### Full-scale speed calibration

The Drive requires 10V input signal for maximum speed. Some motion controllers produce an output signal of 8V to 9V for maximum speed demand, reserving a margin of 1V to 2V to cover tracking errors. **Pr99** sets the scaling of the input speed reference, but this can only be set in steps of 200 or 400 RPM. The full-scale speed calibration pot allows the full scale speed to be adjusted to produce the correct speed for a specified speed reference input signal.

## Defining a ratio using parameter Pr99

Consider a motion controller which gives a reference of 8V for a speed of 2400 RPM. The Drive requires 10V reference to produce full speed. To find the value of **Pr99**, use the following equation:

$$\text{Pr99} = \frac{V_{\text{ref}} * n_{\text{max}}}{V_{\text{out}}}$$

where:

**V<sub>ref</sub>** is the maximum speed reference input voltage of the Drive

**n<sub>max</sub>** is the required maximum speed (2400 RPM)

**V<sub>out</sub>** is the output of the controller corresponding to maximum speed.

The equation then becomes:

$$\text{Pr99} = \frac{10 \times 2400}{8} = 3000$$

Full reference should be applied from the motion controller, and the speed trimmed to the exact requirements using the full scale speed pot.

## Pr6 — Zero-speed offset

An offset in the speed reference signal will cause the motor to rotate slowly when zero speed is demanded. To compensate for this offset, enter the resulting motor speed in **Pr6** to the nearest 0.1RPM.

## 10.6 Resolver phasing

Motor and resolver assemblies are supplied with correct phasing. Use the following procedure only when you are unsure of the phasing of a motor and resolver.



### Warning

**Disconnect the motor shaft from the driven load before using this procedure. During this procedure, the drive will apply rated current to the motor. It is essential that Pr45 is set correctly, or the drive may damage the motor.**

1. Set parameter **b2** at 0.
2. Apply +24V to terminal B14.
3. Set parameter **b49** at 1. The motor shaft will complete one revolution, making 3 steps per pole.
4. Motor must rotate in clockwise (forwards) direction, when viewed from the shaft end of

the motor. The value on the keypad display should also count upward as the motor rotates.

5. If the steps are of unequal size, or in different directions, check the connections to the resolver and motor.
6. The final display indicates the error between the motor and resolver alignment. Note this figure.
7. To return the display to **rdY**, hold the **Mode** button for 2 seconds. Read the value of parameter **Pr16**.
8. Add the value noted in step 6 to the value of **Pr16**, and change the value of **Pr16** to this new figure.  
If the new figure exceeds 2047, subtract 2047 from the figure and enter the result into **Pr16** (eg. Total = 2157. Subtract 2047. Result = 110).
9. Remove the +24V supply from terminal B14.
10. Set parameter **b2** at 1.
11. Set parameter **b99** at 1 to save the new setting.

The resolver signal is now in phase with the motor.

## 10.7 Commissioning

Use the following procedure for each Drive in a multi-axis system:

1. Remove the connections from terminals B9 to B17.
2. If the Drive is one of a multi-axis system, disconnect AC power from all the other Drives in the system.
3. Apply AC power to the Drive. Check the display first shows **04.xx**, then **CAL**, then **rdY**.
4. If using serial communications, check the correct transmission format is being used (refer to Chapter 13 Serial Communications).
5. Unless the **Hold zero speed** function is required, disconnect terminal B6 and check the value of parameter **b18** (digital stop selector) is **0** (default value).
6. Replace the connections that were removed in step 1. Make sure that all terminals are fully tightened on the Drive, motor and resolver.
7. Connect the motor to the load. Perform typical working cycles for a period of at least 15 minutes. Check the following:  
If the value of **b33** = 0, at least one alarm condition exists. Investigate as necessary.  
If the value of **b89** = 1, the Drive has entered

the  $I^2t$  region. The value of  $I^2t$  is displayed in **Pr80** as a percentage (fully-integrated value = 100). It may be necessary to change the setting of **Pr45**, or reduce the duty ratio to reduce the effective current  $I_{eff}$ .

## 10.8 Calibration

In most cases, only small changes will be needed to the values of parameters to optimize the system to the application. If a large change is necessary (for example, due to a load inertia greater than three times the motor inertia), use the following procedure:



### Warning

**During calibration, the motor is required to drive the load. Take care to ensure the following:**

**It is safe for the machinery to be operating**

**The limit switches are not over-ridden**

### Procedure

#### Preliminary settings

1. Connect the motor to the load.
2. Set **b7** at 0 (no ramps).
3. Set **b12** at 0.
4. Set **b18** at 0.
5. Set **Pr58** at maximum speed.
6. Ensure that **Pr99** is set for the full-scale speed of the motor.

#### Digital Reference settings

1. Set **b17** at 1
2. Set **Pr0** at 0
3. Set **Pr1** at  $\text{Pr58} \div 5$
4. Set **Pr2** at 0
5. Set **Pr3** at  $-(\text{Pr58} \div 5)$
6. Set **Pr19** at 2.5 (0.2Hz)

### Note

**This setting depends on the transmission ratio and the mechanical limitations of the system.**

7. Set **Pr21** at 1

#### Analog Reference settings

1. Set **b17** = 0

#### Connecting the terminals

1. Disconnect terminal B6 (Programmable input).
2. Disconnect terminals B9 and B10 (Analog Reference Input).
3. Link terminal B9 to terminal B11 (zero volts).
4. Set up a signal generator to deliver the following output:
  - Square-wave
  - Amplitude:  $-2V$  to  $+2V$
  - Frequency: 0.2Hz (NOTE: see digital reference settings, note 6)
5. Connect the non-inverted output of the signal generator to terminal B10, and the common to terminal B11.
6. Set up an oscilloscope as follows:
  - Both channels at 1V per division
  - Timebase at 20ms per division
  - Channel B trigger
7. Attach probe A of the oscilloscope to terminal B16, and probe B to the signal generator output. Attach the ground clips of the probes to terminal B11 or B18 (0V common)

### Note

**During the next stage, the Drive will cause the motor shaft to oscillate. Adjustment may be made as follows:**

#### Using an analog reference signal

If the amplitude of oscillation is excessive, increase the signal generator frequency. If the speed is too high, reduce the signal generator output voltage to not less than  $\pm 1V$ .

#### Using a digital reference

If the speed is excessive, decrease the values of **Pr0**, **Pr1**, **Pr2**, **Pr3**. Increase the inversion frequency by decreasing the value of **Pr19**.

## 10.9 Methods of speed control

Any of the following three methods can be used as a speed reference:

- Analog input signal
- Digital input signal
- Frequency input signal



**Caution**

**Before changing the method of speed control, set parameter b2 at 0 to disable the Drive. The Drive can subsequently be enabled by setting b2 at 1.**

### Using an analog speed reference

The speed of the motor is controlled by applying an analog speed reference voltage having a maximum range of  $\pm 10V$  to terminals B9 and B10. This voltage can be either a single-ended or differential signal. The maximum speed is set by the value of **Pr99**, but this can be trimmed using the full-scale speed potentiometer. This has a  $\pm 20\%$  window of adjustment around **Pr99**.

Use the following procedure to set up the Drive for analog speed control:

1. Set parameter **b6** at 0.
2. Set parameter **b14** at 1.
3. Set parameter **b17** at 0.

### Using a digital speed reference

The speed of the motor can be controlled by values in **Pr0**, **Pr1**, **Pr2** and **Pr3**. This allows for up to four pre-set speed settings. These values can be selected using any of the following methods:

- **Direct selection** using **Pr20**
- **Sequential selection** using **Pr19**
- **Digital input control** using terminals **B4** and **B5**

The permissible range of values is determined by the value programmed in **Pr99** as follows:

Value of <b>Pr99</b>	Maximum value of reference parameters
200 to 3000	3000
>3000	6000

### Direct selection

1. Set **b6** at 0.
2. Set **b16** at 0.
3. Set **b17** at 1.
4. Set **Pr21** at 0.

Enter the required pre-set speed parameter in **Pr20** (eg. to select **Pr2**, enter 2 in **Pr20**) using serial communications or directly using the Control Keypad.

### Sequential selection

1. Set **b6** at 0.
2. Set **b16** at 0.
3. Set **b17** at 1.
4. Set **Pr21** at 1.

The pre-set speeds are selected in sequence at intervals defined by **Pr19**.

### Digital input control

1. Set **b6** at 0.
2. Set **b16** at 0.
3. Set **b17** at 1.
4. Set **Pr21** at 2.

The required parameter is selected by applying signals to the digital inputs as follows:

Parameter	Terminal	
	b4	b5
Pr0	0V	0V
Pr1	0V	+24V
Pr2	+24V	0V
Pr3	+24V	+24V

### Frequency speed reference

The speed and direction of the motor are controlled by applying a pulse reference to terminal C7 and a direction signal to terminal C8. The speed of the motor is directly controlled by the frequency of the pulse reference signal.

Scaling is as follows:

When **Pr99**  $\leq 3000$ ,  
8192 pulses = 1 revolution, i.e. 409.6kHz gives 3000 RPM

When **Pr99**  $> 3000$ ,  
4096 pulses = 1 revolution, i.e. 409.6kHz gives 6000 RPM

Reliable operation at 409.6kHz occurs when the step height of the frequency input pulse train is  $\geq 15V$ .

Make the following settings for frequency reference control:

1. Set **b14** at 0.
2. Set **b15** at 0.
3. Set **b17** at 0.

Ramps can be selected by setting **b7** at 1. When selected, all three methods of speed control will be subject to the ramps during changes in speed. All ramps (acceleration and deceleration in forward and reverse) are independently controlled, and can be set in terms of milliseconds per 1000 RPM in **Pr9**, **Pr10**, **Pr11** and **Pr12**.

## 10.10 Methods of torque control

Any of the following three methods can be used to run the Drive in torque control:

- Analog input signal
- Digital input signal
- Speed control with external torque limit



### Warning

**Before selecting torque control, set parameter b2 at 0 to disable the Drive, and ensure the motor is at standstill. The Drive can subsequently be enabled by setting b2 at 1.**

### Analog torque control

This mode of operation allows the shaft torque from the motor to be controlled using an analog reference applied to terminals B9 and B10. This input can also be used for master/slave applications where the motors or their loads are coupled together in some way to allow load sharing. The master Drive would be in speed control, and the current demand output from the master would be used as the torque reference for the slave.

Protection against excessive motor speed is given by the Drive tripping on trip **OS** if the speed set in **Pr58** is exceeded.

Use the following procedure to set the Drive in analog torque reference control:

1. Set **b2** at 0 to disable the Drive
2. Ensure the motor is stopped.
3. Set **b6** at 1 to select torque control.
4. Set **b8** at 0 to select analog torque reference

### Digital torque control

The torque reference for the Drive is controlled by parameter **Pr8**, and is set as the percentage of  $I_{max}$ . The range of **Pr8** is  $-100$  to  $+100$ ; the maximum corresponds to the value of maximum current. (See **Pr42** in Chapter 11 *List of Parameters*). This allows the torque output to be controlled using serial communications.

Protection against excessive motor speed is given by the Drive tripping on trip **OS** if the speed set in **Pr58** is exceeded.

Use the following procedure to set the Drive for digital torque reference control:

1. Set **b2** at 0 to disable the Drive.
2. Ensure the motor is stopped.
3. Set **b6** at 1 to select torque control.
4. Set **b8** at 1 to select digital torque reference.

### Speed control with external torque limit

Speed control with external torque limit allows the maximum speed to be controlled while the Drive is in torque control.

When the motor is under load, the Drive tries to run the motor at the speed set by the speed reference. It is prevented from doing so while the output current (torque) is limited by the value set by the torque input signal. When the load reduces sufficiently to reduce the output current to below the value set by the torque input signal, the motor speed attains the value set by the speed reference.

When parameter **b11** is set at 1, terminal B1 becomes an analog speed reference input, and controls parameter **Pr41**. This sets the value of current limit which in effect applies torque control to the motor.

Use the following procedure:

1. Set **b6** at 0 to select speed control. (See **Methods of speed control** for setting up the Drive for the required speed reference).
2. Set **b11** at 1 to select external torque limit.
3. Set **b56** at 0 to disable the external trip function of terminal B1.
4. Apply the required signal to terminal B1 ( $\pm 10V$  gives torque limited to  $\pm 100\%$  of  $I_{pk}$ ). (See **Pr42**).

The instantaneous values of current limit are given as percentages of **Pr41**, and are shown in the following read-only parameters:

- Pr39** Value of the analog current limit signal on terminal B1.
- Pr40** Value of the analog current reference; this can be made available at terminal B16 as the Clamped Current Demand.
- Pr41** Clamped Current Reference threshold, corresponding to the lowest of the values among **Pr42**, **Pr43**, and **Pr39**.
- Pr80** Shows the value of the **I<sup>2</sup>t** computation. **I<sup>2</sup>t** limitation will occur when **Pr80** reaches 100.

## 10.11 Methods of position control

Position control of the Drive uses the up-down count capability of the internal 32-bit buffer. The position reference is applied to this buffer. For every count in the buffer, the Drive will step the motor by  $\frac{1}{16384}$ th of a revolution (0.022°). As the motor rotates, the buffer value is reduced by 1 for each clockwise step, and incremented by 1 for each anti-clockwise step. Since the Drive will always try to reduce the value in the buffer to zero, this error determines the direction in which the motor steps.

There are three methods of position control, as follows:

- Pulse reference
- Digital reference
- Fixed increment reference

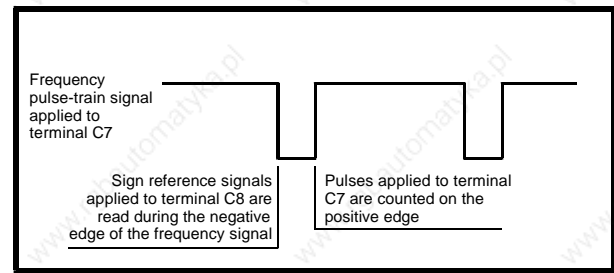
During position control, **b41 Zero speed indication** is set at 1 when the buffer is empty and the motor is at zero speed. This indicates that the motor is *in position*.

### Pulse Reference control

The position reference is applied as a pulse-train to terminal C7 (maximum frequency is 240kHz) and a direction signal to terminal C8. The pulses arriving on terminal C7 are multiplied by a scaling factor set in **Pr70**, and counted by the buffer. The signal present on terminal C8 determines whether the buffer counts up (positive value) or down (negative value). As each pulse enters the buffer, the Drive immediately steps the motor in the appropriate direction, and attempts to keep the net value at zero.

This mode of operation allows the Drive to be directly controlled by a stepper controller. In this case, the ramps should be controlled by the stepper controller. The acceleration and deceleration ramps

on the Drive should be disabled (parameter **b7** set at 0).



**Figure 10-5 Interpretation of pulses using frequency reference control**

The motor will try to run at the speed given by the following equation:

$$\text{Speed} = \frac{\text{Frequency} \times \text{Pr70} \times 60}{16384}$$

If the motor momentarily loses position for any reason, the motor accelerates to its maximum speed until it has regained its correct position. The speed will also be limited if the result of the above equation exceeds the maximum speed limit. The maximum speed limit is dependent on the setting of parameter **b8**. The table below shows how the maximum speed limit is calculated.

Setting of <b>b8</b>	Maximum speed RPM
0	Pr99 + 130
1	Pr24 + 7

Make the following settings for pulse position control:

1. Set **b14** at 0.
2. Set **b15** at 1.
3. Set **b16** at 0.
4. Set **b17** at 0.

### Digital Reference control

The position reference is entered into **Pr75** and **Pr76** using serial communications. The value of **Pr75 must** be entered first, followed by **Pr76**. The new value is entered into the buffer when the value of **Pr76** has been entered. The Drive runs at maximum speed while it is moving into position (see Pulse Reference control above).

The value that will actually be written into the buffer is given by:

$$\text{Position reference} = (\text{Pr76} \times 1000) + \text{Pr75}$$

When reading the total value from the buffer, **Pr75** must be read first. When **Pr75** is accessed, the value in **Pr76** is frozen until it has also been accessed.

Make the following settings for digital pulse position control:

1. Set **b14** at 0.
2. Set **b15** at 1.
3. Set **b16** at 0.
4. Set **b17** at 0.

### Fixed Increment Reference control

Fixed Increment Reference control allows a certain number of pulses to be added or subtracted from the buffer while the Drive is running. This allows a phase shift to be introduced between the master and any slave Drives. The function is controlled using the digital inputs on terminals B4 and B5 (see the table below). The increment value is set in **Pr20**. The buffer is updated every 5ms.

B4	B5	Value of Pr20
+24V	0V or open circuit	Added to count
0V or open circuit	+24V	Subtracted from count
0V or open circuit	0V or open circuit	No effect on count
+24V	+24V	No effect on count

Make the following settings for fixed increment position control:

1. Set **b14** at 0.
2. Set **b15** at 1.
3. Set **b16** at 1.
4. Set **b17** at 0.

### Position Hold at zero speed

When the value held in the buffer is zero, the Drive holds the motor at zero speed but any position reference is lost. The buffer is cleared to under either of the following conditions:

- When the Drive is enabled
- When a Stop signal is received

When the motor is required to be held at zero speed for a period of time before the final position is reached (eg. when the machine door is opened) without clearing the value in the buffer (and hence losing the position reference), the limit-switch function should be used by setting **b16** at 1. This

holds the motor at zero speed by inhibiting rotation in either direction.

### Spindle orientation

This function allows the motor to be stopped at a pre-defined position when under analog or digital speed reference control. The orientation position for the shaft is set in **Pr27**. The range of **Pr27** is 0 to 2047, giving a resolution of 0.176°. The orientation command can be given in either of two ways as follows:

Set **b53** and **b18** at 1 (Stop, orientate and hold with ramps) using serial communications.

Set **b53** at 1, and apply a Stop signal to terminal B6.

When the Stop signal is received, the motor decelerates to the orientation speed set in **Pr54**. The motor continues rotating in the same direction until the orientation position is reached.

Parameter **b41** (Shaft orientation) is set at 1 when the following applies:

$$\text{Pr53} \geq \text{Pr27} - \text{Pr83}$$

During orientation, the value of **Pr37** is used for the position loop gain.

### Methods of stopping

#### Auto-stop

If the DC bus voltage falls below the value set in **Pr5**, **b18** is automatically set at 1 and the motor is stopped without deceleration ramp (stopping under current limit) (see *Normal stop-and-hold* below). The motor remains stopped even if the DC bus voltage recovers immediately. To re-start the motor, use serial communications to set **b18** at 0.

#### Normal stop-and-hold

When a Stop signal is applied to terminal B6, or **b18** is set at 1, the Drive brings the motor to standstill, but the Drive does not become disabled. The motor can be stopped without deceleration ramp (stopping under current limit), or ramps can be included to make the stop smoother. This keeps the motor under torque control, and consequently holds the motor at the stopped position. The motor stops at a random position unless some external control loop is used.

Ramps are selected by setting **b22** at 1. When a Stop signal is received, the Drive decelerates the motor at the rate given in **Pr11** or **Pr12**. Selection of ramps for stop-and-hold mode is independent of whether ramps are selected to act on the speed reference.

Use the following procedure to select Stop-and-hold mode:

1. Configure terminal B6 as follows for the voltage sense of the Stop signal:

b88 setting	Stop signal
0	+24V
1	0V

2. Set **b22** at 1 for stopping with ramps.
3. Set **Pr11** and **Pr12** for deceleration rate in milliseconds per 1000 RPM.

### Limit-switch stop-and-hold

When a limit-switch is triggered, the Drive inhibits rotation in that direction, and stops the motor. The motor can be stopped without deceleration ramp (stopping under current limit), or ramps can be included to make the stop smoother. When the motor has stopped, the Drive will keep the motor in torque to prevent the mechanical system from moving past the end-stop.

Ramps are selected by setting **b23** at 1. When the limit-switch is activated, the Drive decelerates the motor at the rate set in **Pr11** or **Pr12**. Selection of ramps for the limit-switch stop-and-hold mode is independent of whether or not ramps are selected to act on the speed reference.

Use the following procedure to configure the limit-switch stop functions:

1. Set **b16** at 1.
2. Set **b23** at 1 to select ramps.
3. Apply the limit-switch signals as follows:

Limit-switch	Terminal	
	B4	B5
Forward	X	0
Reverse	0	X

0 = logic 0 = 0V = Stop  
(X = don't care)

### Stop, hold and orientate

See *Spindle orientation* earlier in this chapter.

## 10.12 Quick reference

### Note

**A maximum speed limit is programmable in Pr58. The Drive is disabled if the motor speed exceeds the programmed value.**

### Speed control

Make the following settings:

Type of speed reference	b6	b14	b15	b17
Analog	0	1	X	0
Digital	0	X	X	1
Frequency	0	0	0	0

Ramps can be applied to all types of speed reference by setting **b7** at 1.

### Torque control

Make the following settings:

Type of torque reference	b6	b8	b11	b56
Analog	1	0	0	1
Digital	1	1	0	1
Speed control with external torque limit	0	X	1	0

### Position control

Make the following settings:

Type of position Reference	b14	b15	b16	b17
Pulse	0	1	1	0
Digital	0	1	1	0
Fixed increment	0	1	0	0



## 10.13 Programmable outputs

### Digital outputs

The digital outputs on terminals B7 and B8 can be configured to show the state of a bit parameter. These signals can then be used to indicate the present status of the Drive.

Terminal B7 is selected using **Pr30**.

Terminal B8 is selected using **Pr31**.

The following parameters can be selected for terminals B7 and B8:

Pr30 Pr31	Parameter	Indication
0	b89	I <sup>2</sup> t integrating (alarm)
1	b91	Over-temperature (pre-alarm)
2	b84	Over-current (alarm)
3	b38	Direction of motor rotation
4	b41	Motor status (running/stopped)
5	b42	At-speed status
6	b48	Speed loop saturation status
7	b4	Drive enabled status
8	b95	Braking resistor overload

### Programmable analog output

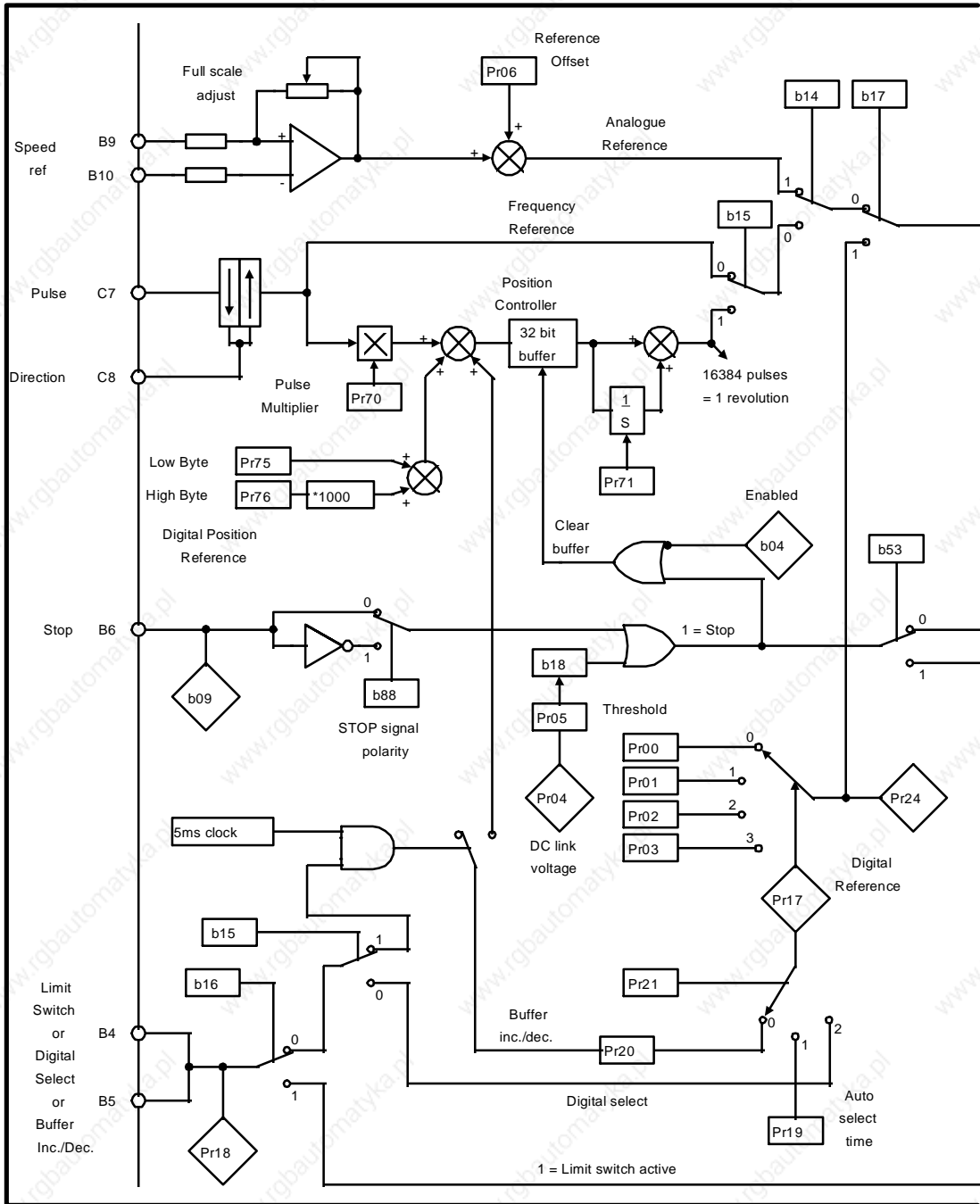
The analog output on terminal B16 can be configured to produce an analog signal proportional to one of the following:

- Motor current
- Clamped current demand
- Post-ramp speed reference

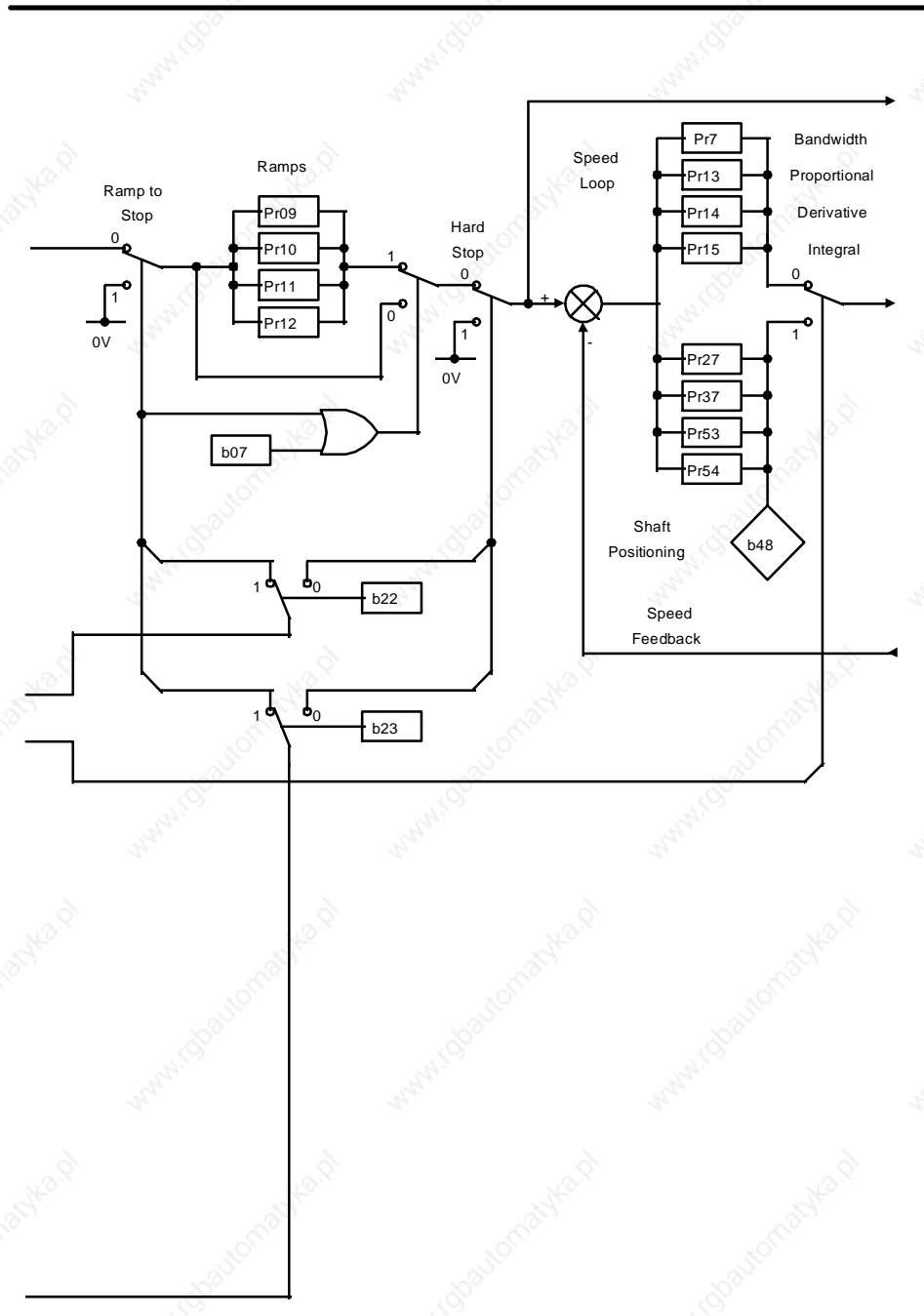
Make the following settings to select the required indication:

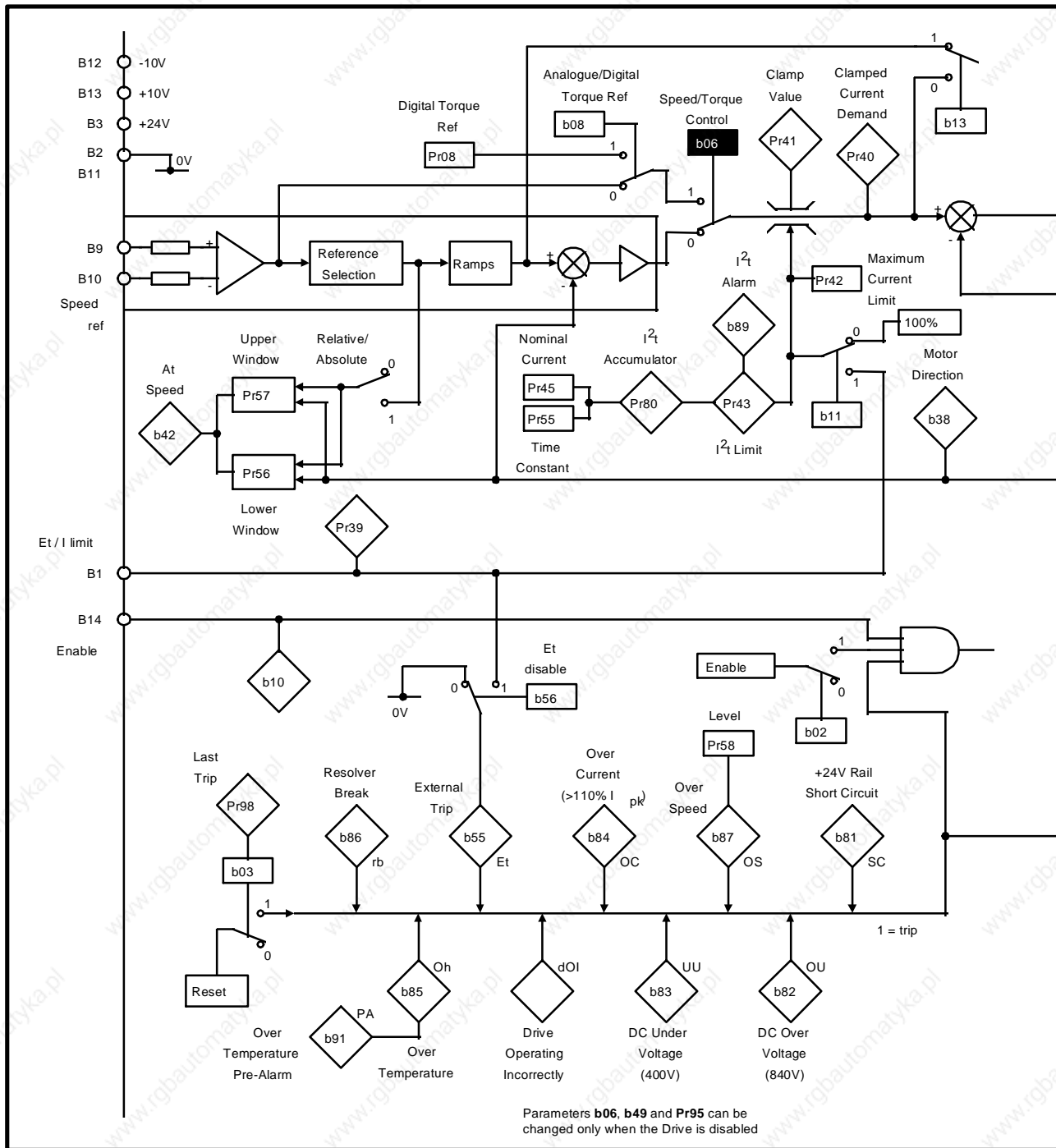
b12	b13	Parameter	Indication
1	X		Motor current. Scaling: 16V pk-pk = I <sub>peak-peak</sub>
0	0	Pr40	Clamped current demand. This output can be used as the torque reference for a slave Drive (See Methods of torque control). Scaling: ±10V = ±100% of I <sub>max</sub>
0	1		Post-ramp speed reference. Scaling: ±5V = ±6000 RPM

The output from terminal B17 is the analog tacho signal.

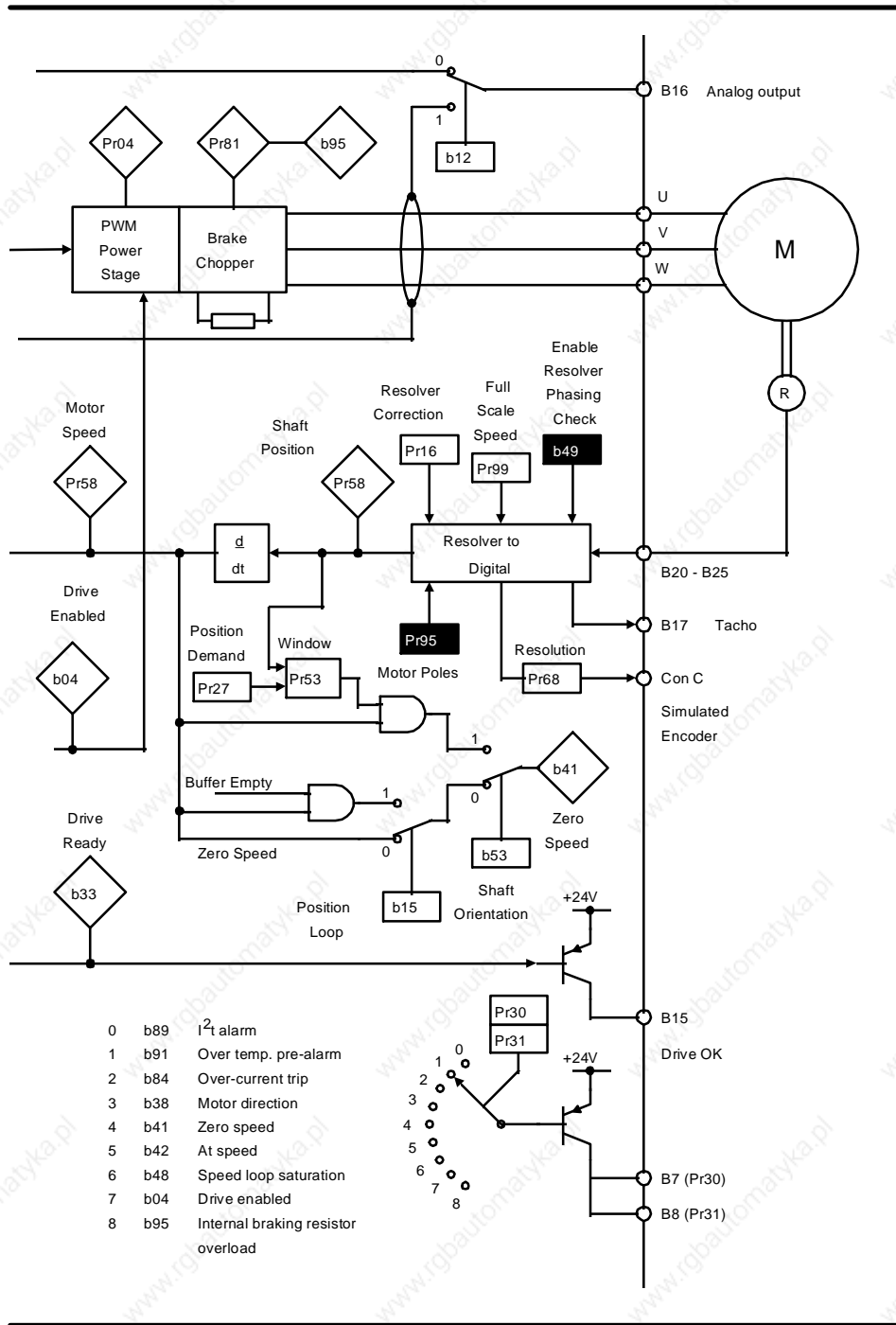


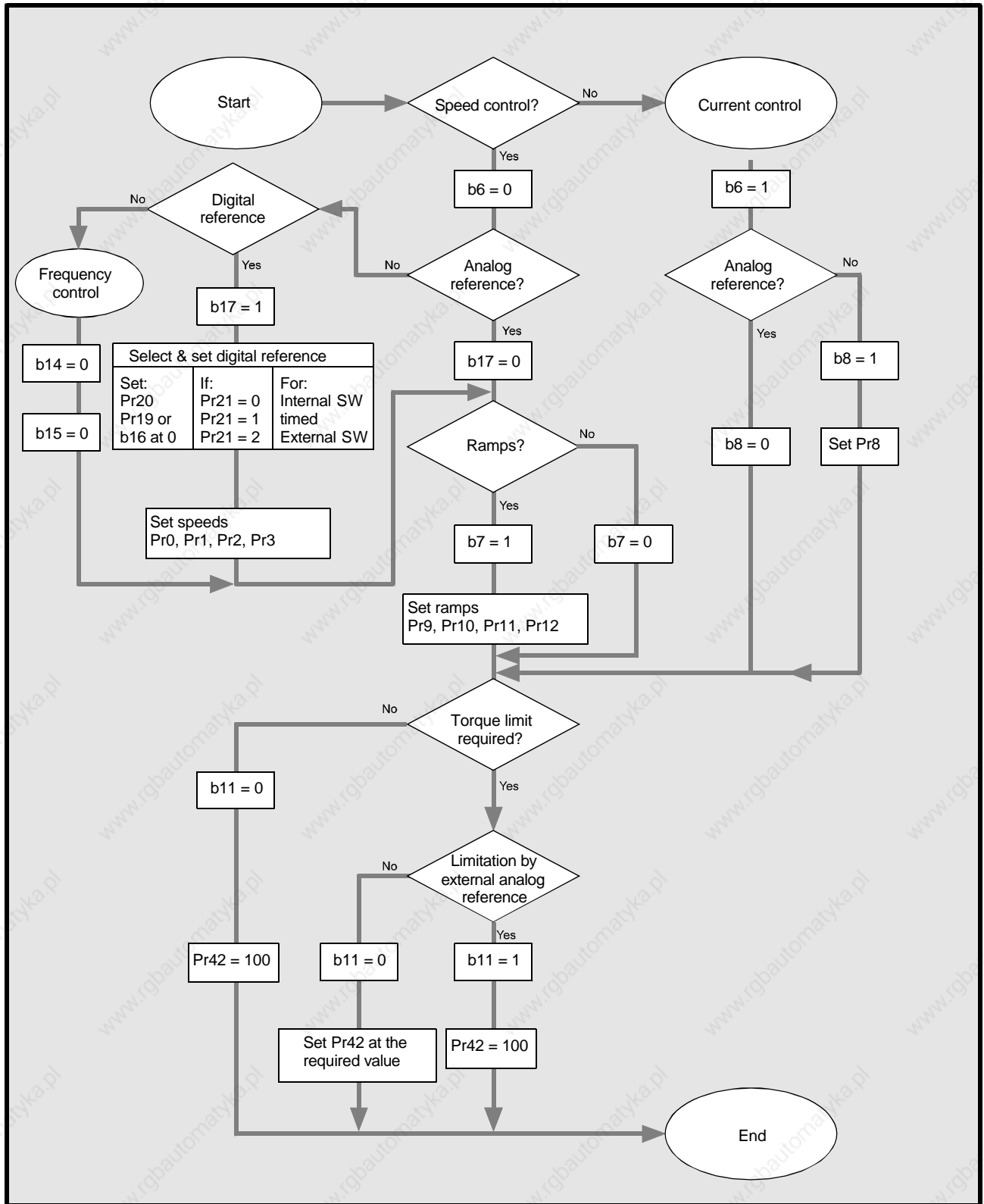
**Figure 10–6 Logic diagram showing speed reference selection and position control**



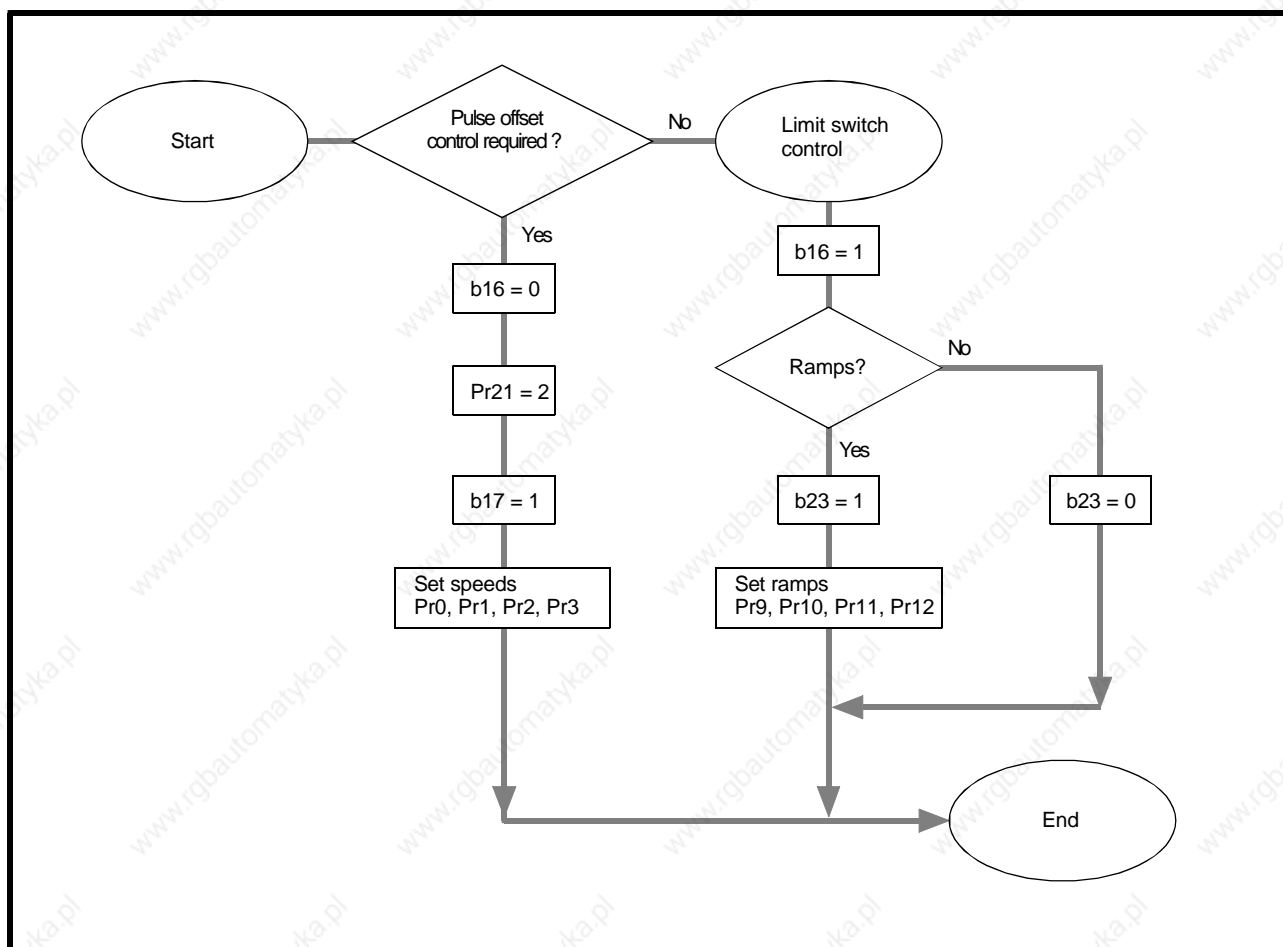


**Figure 10-7 Logic diagram showing the torque loop, trip logic and I/O**

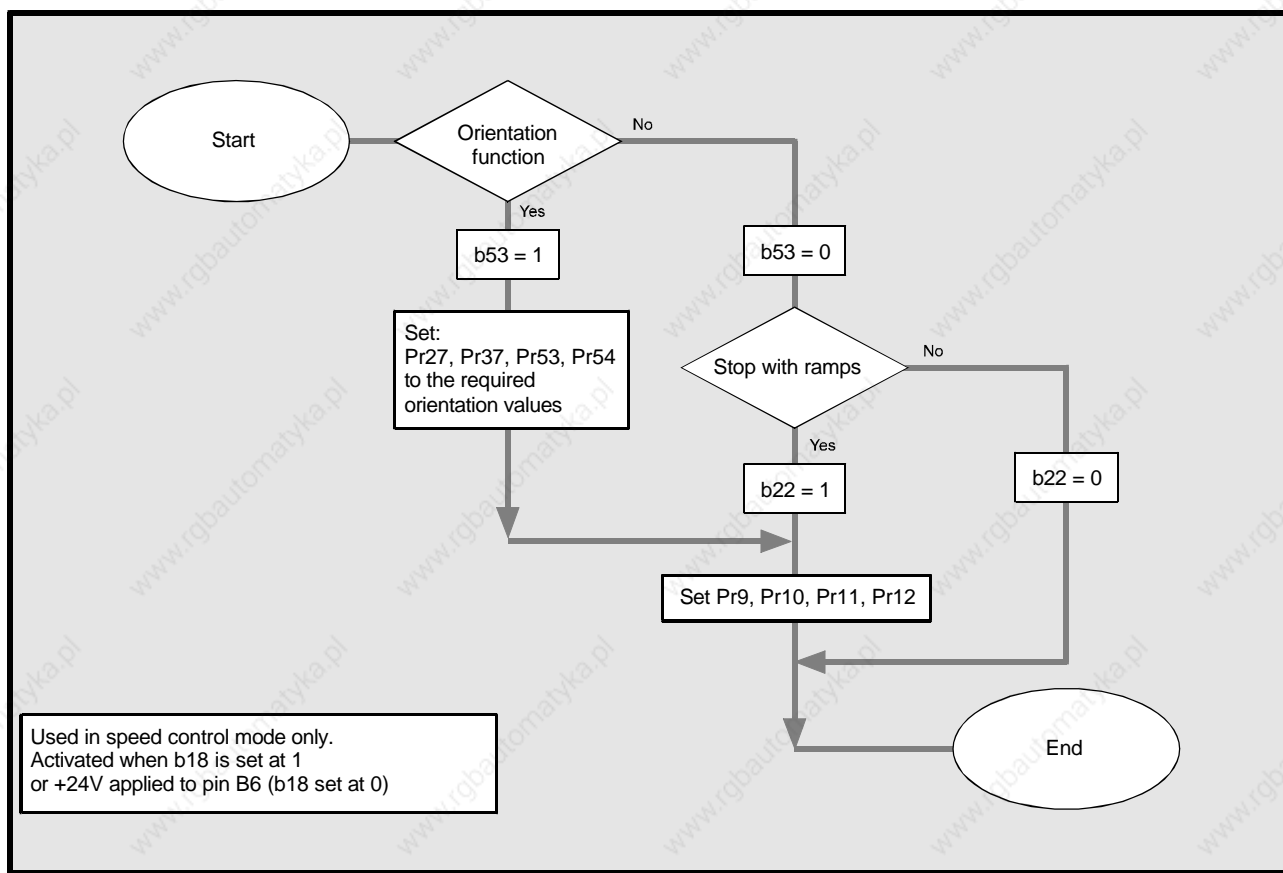




**Figure 10–8 Select speed control or current control**



**Figure 10–9 Select pulse offset control switching, or limit-switch function**



**Figure 10–10 Select Stop-and-hold or Stop-orientate and hold**



# 11 List of Parameters

## 11.1 Variable parameters

### Note

**R-W** = Read-write parameter  
**RO** = Read-only parameter

Selection of **Pr0**, **Pr1**, **Pr2**, and **Pr3** is controlled by **Pr17**, which receives its coding from the values of **Pr18**, **Pr19** and **Pr20**, as selected by **b16** and **Pr21**. Refer to **Pr17**, **Pr18**, **Pr19**, **Pr20**, **Pr21** and **b16**.

<b>Pr0</b>	<b>Programmable digital speed reference</b>				R-W
(Range: see below)	RPM	Def. val.	0	Res.	1

-3000 to 3000 RPM when **Pr99** = 200 to 3000  
 -6000 to +6000 RPM when **Pr99** = 3200 to 6000

<b>Pr1</b>	<b>Programmable digital speed reference</b>				R-W
(Range: see below)	RPM	Def. val.	0	Res.	1

-3000 to 3000 RPM when **Pr99** = 200 to 3000  
 -6000 to +6000 RPM when **Pr99** = 3200 to 6000

<b>Pr2</b>	<b>Programmable digital speed reference</b>				R-W
(Range: see below)	RPM	Def. val.	0	Res.	1

-3000 to 3000 RPM when **Pr99** = 200 to 3000  
 -6000 to +6000 RPM when **Pr99** = 3200 to 6000

<b>Pr3</b>	<b>Programmable digital speed reference</b>				R-W
(Range: see below)	RPM	Def. val.	0	Res.	1

-3000 to 3000 RPM when **Pr99** = 200 to 3000  
 -6000 to +6000 RPM when **Pr99** = 3200 to 6000

<b>Pr4</b>	<b>Voltage level of DC bus</b>				RO
0 to 1024	V	Def. val.		Res.	4

<b>Pr5</b>	<b>Auto-Stop function</b>				R-W
0 to 1020	V	Def. val.	0	Res.	1V

If the DC bus voltage falls below the value of **Pr5**, the Drive stops automatically.

(See *Auto Stop function*)

<b>Pr6</b>	<b>Analog reference input offset</b>				R-W
-50.0 to +50.0	RPM	Def. val.	0.0	Res.	0.1

Permits the user to apply a correction to an offset in the analog speed reference which would cause slow rotation of the motor when zero speed is intended.

<b>Pr7</b>	<b>Speed loop bandwidth limit</b>				R-W
1 to 7	RPM	Def. val.	1	Res.	1

Used in conjunction with **Pr13**, **Pr14**, **Pr15** to minimize instability of the speed loop caused by resonance in the mechanical transmission, or by high inertia of the driven load.

Value of Pr7	Bandwidth limit Hz
1	320
2	160
3	80
4	40
5	20
6	10
7	5

<b>Pr8</b>	<b>Digital current reference</b>				R-W
± 100	%	Def. val.	0	Res.	1

User-programmable current (torque) reference, as a percentage of  $I_{pk}$ . Polarity indicates the direction of motor rotation.

<b>Pr9</b>	<b>Acceleration ramp – forward</b>				R-W
1 to 3000	ms	Def. val.	200	Res.	1

Slope in milliseconds per 1000 RPM.

<b>Pr10</b>	<b>Acceleration ramp – reverse</b>				R-W
1 to 3000	ms	Def. val.	200	Res.	1

Slope in milliseconds per 1000 RPM.

<b>Pr11</b>	<b>Deceleration ramp – forward</b>	R–W
1 to 3000	ms	Def. val. 200 Res. 1

Slope in milliseconds per 1000 RPM.

<b>Pr12</b>	<b>Deceleration ramp – reverse</b>	R–W
1 to 3000	ms	Def. val. 200 Res. 1

Slope in milliseconds per 1000 RPM.

<b>Pr13</b>	<b>Proportional gain</b>	R–W
0 to 255		Def. val. 30 Res. 1

<b>Pr14</b>	<b>Derivative gain</b>	R–W
0 to 128		Def. val. 30 Res. 1

<b>Pr15</b>	<b>Integral gain</b>	R–W
0 to 255		Def. val. 30 Res. 1

<b>Pr16</b>	<b>Resolver Phasing</b>	R–W
0 to 2047		Def. val. 0 Res. 1

Value of the resolver phase correction. Refer to *Resolver Phasing* in Chapter 10 Getting Started.

<b>Pr17</b>	<b>Digital reference</b>	RO
0 to 3		Def. val. Res.

Indicates the reference selected in **Pr21**

<b>Pr18</b>	<b>Digital input configuration (terminals B4 and B5)</b>	RO
0 to 3		Def. val. Res.

Indicates the signals on terminals B4 and B5, as follows:

0V or open-circuit = 0  
+24V = 1

The indications are as follows:

Terminal		Pr18
B4	B5	
0	0	0
0	1	1
1	0	2
1	1	3

<b>Pr19</b>	<b>Digital reference scan time</b>	R–W
0.1 to 600.0	s	Def. val. 10.0s Res. 0.1

<b>Pr20</b>	<b>Digital reference selector / Number of offset pulses</b>	R–W
(See below)		Def. val. 0 Res. 1

### Normal control

Range: 0 to 3

Select the required digital reference.

### Position control

Range: 0 to 255

Resolution: 1

Enter the required number of position counts in the position buffer every 5 ms.

<b>Pr21</b>	<b>Digital reference selector enable</b>	R–W
0, 1 or 2		Def. val. 0 Res. 1

When **Pr21** = 0, **Pr20** is used as digital reference selector.

When **Pr21** = 1, sequential selector **Pr19** is enabled.

When **Pr21** = 2 and **b16** = 0, digital inputs are enabled.

<b>Pr22</b>	<b>Drive address</b>	R–W
1 to 32		Def. val. 1 Res. 1

A Drive address is required when serial communications are used. Each Drive on a serial communications link must have an individual address.

<b>Pr23</b>	<b>Baud rate</b>	R–W
300 to 19200		Def. val. 9600 Res.

This parameter can be set only at the control keypad, not by using serial communications.

Available values are as follows:

300, 600 1200, 2400, 4800, 9600, 19200

The host computer must be set at the same Baud rate as the Drive.

<b>Pr24</b>	<b>Digital run reference</b>	RO
±6000	RPM	Def. val. Res. 1

Indicates the value of the selected digital reference in RPM at the start of the speed loop.

<b>Pr25</b>	<b>Security code</b>	R-W
1 to 9999	Def. val. 0	Res. 1

Security gives write protection to parameters. Refer to Setting up a security code in Chapter 9.

<b>Pr26</b>	<b>Drive model code</b>	RO
(See below)	Def. val.	Res.

The model number is coded as follows:

0	DBE140
1	DBE220
2	DBE420
3	DBE600
7	DBE750
11	DBE1100S
12	DBE1500, DBE2200

<b>Pr27</b>	<b>Shaft orientation function in resolver steps</b>	R-W
0 to 2047	steps	Def. val. 0 Res. 1

When **b53** = 1, **Pr27** determines the shaft orientation as directed by either **b18** or the input at terminal **B6**. See **Pr37**, **Pr53**, **Pr54**, **Pr83**, **b41**.

<b>Pr30</b>	<b>Digital output selector 1</b>	R-W
0 to 8	Def. val. 0	Res. 1

Selects the source parameter for terminal B7.

Value of Pr30	Parameter selected
0	<b>b89</b> I <sup>2</sup> t alarm
1	<b>b91</b> Temperature pre-alarm
2	<b>b84</b> Current limit alarm
3	<b>b38</b> Present direction
4	<b>b41</b> Motor stopped
5	<b>b42</b> At Speed
6	<b>b48</b> Speed loop saturation
7	<b>b4</b> Drive enable status
8	<b>b95</b> Braking resistor overload

<b>Pr31</b>	<b>Digital output selector 0</b>	R-W
0 to 8	Def. val. 1	Res. 1

Selects the source parameter for terminal B8.

Value of Pr31	Parameter selected
0	<b>b89</b> I <sup>2</sup> t alarm
1	<b>b91</b> Temperature pre-alarm
2	<b>b84</b> Current limit alarm
3	<b>b38</b> Present direction
4	<b>b41</b> Motor stopped
5	<b>b42</b> At Speed
6	<b>b48</b> Speed loop saturation
7	<b>b4</b> Drive enable status
8	<b>b95</b> Braking resistor overload

<b>Pr37</b>	<b>Orientation (position) loop gain</b>	R-W
0 to 50	Def. val. 12	Res. 1

When the orientation function is selected (Normal stop while **b53** = 1), the Drive automatically sets the orientation loop gain.

<b>Pr39</b>	<b>Analog current limit input</b>	RO
-100 to +100 %	Def. val.	Res. 1

Indicates the value of the reference voltage on analog input terminal B1. -100% to +100% represents -10V to +10V.

<b>Pr40</b>	<b>Clamped current demand</b>	RO
-100 to +100 %	Def. val.	Res. 1

Indicates the value of the current after limiting by **Pr41**.

<b>Pr41</b>	<b>Current limitation value</b>	RO
0 to +100 %	Def. val.	Res. 1

Indicates the lowest value set in the following parameters:

- I<sup>2</sup>t limit (**Pr43**)
- Analog limit (rectified) (**Pr39**) when **b11** = 1
- Digital limit **Pr42**

0 is shown when the Drive is disabled.

<b>Pr42</b>	<b>Maximum current limit</b>					R-W
0 to 100	%	Def. val.	100	Res.	1	

Sets the maximum peak motor current ( $I_{max}$ ) available from the Drive, as a percentage of  $I_{pk}$ .

<b>Pr43</b>	<b>I<sup>2</sup>t limit</b>					RO
0 to 100	%	Def. val.		Res.	1	

When **Pr43** = 100, this indicates current is not in the I<sup>2</sup>t region.

When **Pr43** shows percentage of  $I_{pk}$ , current is in the I<sup>2</sup>t region.

<b>Pr45</b>	<b>Nominal current</b>					R-W
See below	%	Def. val.	50	Res.	1	

Sets the maximum continuous motor current ( $I_{nom}$ ) available from the Drive, as a percentage of  $I_{pk}$ .

Range:

DBE140 to DBE750: 20% to 50%

DBE1100S to DBE2200: 20% to 67%

<b>Pr53</b>	<b>Shaft orientation window</b>					R-W
0 to 100	stops	Def. val.	10	Res.	1	

Defines a window either side of the value programmed in **Pr27** within which it is assumed that the motor shaft is correctly orientated when stop is selected and **b53** = 1. See **Pr27**.

<b>Pr54</b>	<b>Speed reference during orientation</b>					R-W
10 to 200	RPM	Def. val.	150	Res.	1	

Speed in RPM adopted during shaft orientation. See **Pr27**.

<b>Pr55</b>	<b>Thermal time-constant of motor</b>					R-W
0.4 to 10.0	secs	Def. val.	7.0s	Res.	0.1s	

Enter the value for the motor.

<b>Pr56</b>	<b>Motor At-speed window – lower limit</b>					R-W
±6000	RPM	Def. val.	-5	Res.	1	

Refer also to **Pr57**, **b42** and **b96**.

<b>Pr57</b>	<b>Motor At-Speed window – upper limit</b>					R-W
±6000	RPM	Def. val.	5	Res.	1	

Refer also to **Pr56**, **b42** and **b96**.

<b>Pr58</b>	<b>Maximum speed limit</b>					R-W
0 to 6000	RPM	Def. val.	3200	Res.	1	

If the motor exceeds this limit, an over-speed trip occurs. See **b87**.

<b>Pr59</b>	<b>Motor speed</b>					RO
0 to 6500	RPM	Def. val.		Res.	1	

<b>Pr68</b>	<b>Simulated encoder output resolution</b>					R-W
0 to 3		Def. val.	1	Res.		

When **Pr68** = 0, pulses per revolution = 256

When **Pr68** = 1, pulses per revolution = 512

When **Pr68** = 2, pulses per revolution = 1024

When **Pr68** = 3, pulses per revolution = 2048

#### Note

**When Pr68 is set at 3, the maximum permissible speed is 3000 RPM**

<b>Pr70</b>	<b>Position Reference Input Scaling</b>					R-W
4 to 16384		Def. val.	4	Res.	1	

The number of pulses at the input is multiplied by **Pr70**. For each resulting pulse, the motor shaft will rotate **Pr70**/16384 part of a revolution. Refer also to **Pr71**.

<b>Pr71</b>	<b>Position Loop Integral Gain</b>					R-W
0 to 255		Def. val.	0	Res.	1	

When the Drive is set up to operate in position control with a frequency input signal, **Pr71** is used to add integral gain to eliminate steady-state position error.

<b>Pr75</b>	<b>Position Reference using Serial Communications</b>				R-W
16384	steps/rev	Def. val.	0	Res.	

These two parameters permit serial communications to be used to control the position reference. The position reference value is  $[(Pr76 \times 1000) + Pr75]$ . Any changes to the values of **Pr75** and **Pr76** are effective only after the values of *both* parameters have been written.

<b>Pr80</b>	<b>I<sup>2</sup>t Level</b>				RO
0 to 100	%	Def. val.		Res.	0.1

Displays values corresponding to I<sup>2</sup>t accumulation. I<sup>2</sup>t limit is activated at 100%.

<b>Pr81</b>	<b>Braking resistor protection</b>				RO
0 to 1999.9		Def. val.		Res.	0.1

Displays a value proportional to the power dissipated in the braking circuit. When **Pr81** reaches 100, parameter **b95** is set at 1.

<b>Pr83</b>	<b>Rotor position</b>				RO
0 to 2047		Def. val.		Res.	1

Shows the shaft position at all times.

<b>Pr95</b>	<b>Number of Motor Poles</b>				R-W
		Def. val.	6	Res.	

4, 6, or 8 poles can be set.

<b>Pr97</b>	<b>Software version number</b>				RO
		Def. val.		Res.	

(This manual applies to V4.XX.XX software.)

<b>Pr98</b>	<b>Last alarm store</b>				RO
		Def. val.		Res.	

Displays the cause of the last trip. **Pr98** is cleared when the Drive is reset by setting **b03** at 1. When **Pr98** is interrogated using Serial Communications, a number representing the trip is transmitted. The numbers are as follows:

No.	Condition	Trip code
0	Drive normal	
1	Overvoltage	OV
2	Undervoltage	OU
3	Overcurrent	OC
4	Overtemperature	Oh
5	Resolver break	rb
6	I <sup>2</sup> t integrating	It
7	Temperature pre-alarm	PA
8	Overspeed	OS
9	Digital output short circuit	SC
10	External trip	Et
11	Internal fault	dOI or Err

<b>Pr99</b>	<b>Full Scale Speed</b>				R-W
200 to 3000	RPM	Def. val.	3000	Res.	200
3200 to 6000					400

## 11.2 Bit parameters

<b>b0</b>	<b>Enable change of security code</b>				R-W
0 or 1		Def. val.	0	Res.	

Set at 1 to enable the security code to be changed to any valid number. Refer to **Pr25**.

<b>b1</b>	<b>Recall last parameter settings from EEPROM</b>				R-W
0 or 1		Def. val.	0	Res.	

Return to the last-written parameter values. Set **b2** at 0 to allow parameter recall. The display will show **REAd** during this process. Related to **b5** and **b99**.

<b>b2</b>	<b>Drive enable</b>				R-W
0 or 1		Def. val.	1	Res.	

When **b2** = 0, the Drive is disabled.  
When **b2** = 1, the Drive is enabled.

Refer to terminal B14.

<b>b3</b>	<b>Alarm reset</b>	R-W
0 or 1	Def. val. 0	Res.

Set **b3** at 1 to accept and cancel any alarm or trip, and reset the last alarm store. Display will show **rSt** during reset. Refer to **Pr98**.

**Note**

**Set b2 at 0 or apply 0V to terminal B14 to disable the Drive before resetting the alarm.**

<b>b4</b>	<b>Drive enable status</b>	RO
	Def. val.	Res.

**b4** = 0 indicates the Drive is disabled (by **b2** = 0, an alarm, or the Drive enable signal being removed from terminal B14).

**b4** = 1 indicates the Drive is enabled.

<b>b5</b>	<b>Recall default values from PROM</b>	R-W
0 or 1	Def. val. 0	Res.


Recalls the default values of all parameters from PROM and enters them in RAM for immediate application. The display shows **dEf** while default values are loaded. Related to **b1** and **b99**.

<b>b6</b>	<b>Reference selector</b>	R-W
0 or 1	Def. val. 0	Res.

Refer to **b8**.

When **b6** = 0, the reference is the speed loop output.

When **b6** = 1, analog or digital current reference selected.



**Change the value of b6 only when the Drive is disabled by setting b2 at 0, and the motor is stopped**

**Warning**

<b>b7</b>	<b>Enable accel/decel ramps</b>	R-W
0 or 1	Def. val. 0	Res.

Change speed with or without ramps.

When **b7** = 0, ramps are disabled.

When **b7** = 1, ramps are enabled.

<b>b8</b>	<b>Current reference mode selector</b>	R-W
0 or 1	Def. val. 0	Res.

When **b8** = 0, analog torque reference is selected.

When **b8** = 1, digital torque reference is selected (see **Pr8**).

<b>b9</b>	<b>Digital stop function status</b>	RO
	Def. val.	Res.

Indicates the logic level present on terminal B6.

When the input at terminal B6 is 0V selection is by software only. Refer to **b18**.

When the input at terminal B6 is +24V, and **b53** = 1, the stop function is to stop in position.

If the input at terminal B6 is +24V, **b53** = 0, and **b22** = 0, **b9** = 0, the stop function is to hold zero speed without ramps.

When the input at terminal B6 is +24V, **b53** = 0, and **b22** = 1, **b9** = 1, the stop function is to hold zero speed with ramps. Refer to **b18**.

<b>b10</b>	<b>Digital enable state</b>	RO
	Def. val.	Res.

Indicates the logic input state at terminal B14.

When the logic state at B14 is 0, **b10** is 0 and the Drive is not enabled.

When the logic state at B14 is 1, **b10** is 1 and the Drive is enabled depending on the setting of **b2**.

<b>b11</b>	<b>Current limit selector</b>	R-W
0 or 1	Def. val. 0	Res.

Selects the current limit.

When **b11** is set at 0, the current limit is  $I_{max}$ .

When **b11** is set at 1, the current limit is determined by the signal applied to terminal B1.

<b>b12</b>	<b>Analog Output Selector</b>	R-W
	Def. val. 0	Res.

Refer to **b13**.

Selects the analog signal output produced at terminal B16.

When **b12** is set at 0, refer to **b13**.

When **b12** is set at 1, the output signal represents the motor current ( $16V\ pk-pk \equiv I_{peak}$ ).

<b>b13</b>	<b>Analog Output Selector</b>				R–W
0 or 1	Def. val.	0	Res.		

When **b12** = 0, **b13** is used to select the signal source.

When **b13** is set at 0, clamped current demand (**Pr40**) is selected ( $\pm 10V \equiv \pm 100\%$ ).

When **b13** is set at 1, post-ramp speed reference is selected ( $5V \equiv 6000RPM$  request).

<b>b14</b>	<b>Pulse/analog reference selector</b>				R–W
0 or 1	Def. val.	1	Res.		

When **b17** is set at 0 and **b14** is set at 0, pulse-train input is selected (terminal C7).

When **b17** is set at 0 and **b14** is set at 1, analog speed reference ( $\pm 10V$ ) is selected (terminals B9 and B10).

<b>b15</b>	<b>Pulse/position control selector</b>				R–W
0 or 1	Def. val.	0	Res.		

When **b15** is set at 0, pulse control is selected.

When **b15** is set at 1, position control is selected.

<b>b16</b>	<b>Pulse offset control / limit switch selector</b>				R–W
0 or 1	Def. val.	0	Res.		

Selects the function of terminals B4 and B5.

When **b16** is set at 0, terminals B4 and B5 are used to control the application of an offset count to the 32-bit buffer.

When **b16** is set at 1, terminals B4 and B5 are used for limit switch inputs.

<b>b17</b>	<b>Speed reference input selector</b>				R–W
0 or 1	Def. val.	0	Res.		

Selects analog speed reference at terminals B9 and B10 or digital reference.

When **b17** is set at 0, analog speed reference is selected.

When **b17** is set at 1, digital speed reference is selected; **b14** has no effect.

<b>b18</b>	<b>Digital stop selector</b>				R–W
0 or 1	Def. val.	0	Res.		

Selects the stop function without an input applied to terminal B6.

When **b18** = 0, the stop function is controlled by applying a signal to terminal B6. Refer to **b9**.

When **b18** = 1, and **b53** = 1, the stop function is to stop to position with ramp and hold.

When **b18** = 1, **b53** = 0, and **b22** = 0, the stop function is to stop without ramps and hold.

When **b18** = 1, **b53** = 0, and **b22** = 1, the stop function is to stop with ramps and hold.

Refer also to **b7**, **b9**, **b23**.

<b>b21</b>	<b>BCC enable</b>				R–W
0 or 1	Def. val.	1	Res.		

When **b21** is set at 0, BCC is disabled.

When **b21** is set at 1, BCC enabled.

See Chapter 13 *Serial Communications*.

<b>b22</b>	<b>Ramp function for Normal stop</b>				R–W
0 or 1	Def. val.	1	Res.		

Selects with or without ramps for stop-and-hold.

When **b22** is set at 0, **without ramps** is selected.

When **b22** is set at 1, **with ramps** is selected.

#### Note

**Stopping with orientation always uses ramps irrespective of the setting of b22 (see b53).**

<b>b23</b>	<b>Limit switch ramp function</b>				R–W
0 or 1	Def. val.	1	Res.		

Selects with or without ramps for limit-switch stop.

When **b23** is set at 0, without ramps is selected.

When **b23** is set at 1, with ramps is selected.

<b>b33</b>	<b>Alarm status</b>				RO
	Def. val.		Res.		

When **b33** is set at 0, at least one alarm is active.

When **b33** is set at 1, no alarm is active.

The status of this parameter is produced as a logic signal on terminal B15.

<b>b38</b>	<b>Direction of motor rotation</b>	RO
	Def. val.	Res.

Indicates the direction of rotation when seen at the drive shaft end of the motor.

**b38** = 0 indicates the motor is rotating in the reverse (counterclockwise) direction.

**b38** = 1, indicates the motor is rotating in the forward (clockwise) direction.

<b>b41</b>	<b>Zero speed or shaft orientation status</b>	RO
	Def. val.	Res.

**b53** = 0, **b41** = 0 indicates motor not at zero speed.

**b53** = 1, **b41** = 0 indicates shaft not orientated.

**b53** = 0, **b41** = 1 indicates motor at zero speed.

**b53** = 1, **b41** = 1 indicates shaft is orientated.

See **Pr27**.

When the Drive is being used for position control, **b41** indicates **In Position**.

<b>b42</b>	<b>At-speed status</b>	RO
	Def. val.	Res.

**b42** = 0 indicates motor not at speed — motor speed is outside the range defined by **Pr56** and **Pr57**.

**b42** = 1 indicates motor **At speed** — motor speed is within the range defined by **Pr56** and **Pr57**.

Refer also to **Pr56**, **Pr57** and **b96**.

<b>b48</b>	<b>Speed loop saturation status</b>	RO
	Def. val.	Res.

Indicates whether the speed loop is operating linearly or is in saturation.

**b48** = 0 indicates the speed loop is in linear operation.

**b48** = 1 indicates the speed loop is saturated.

<b>b49</b>	<b>Resolver phasing</b>	R-W
0 or 1	Def. val.	0 Res.

When **b49** is set at 0, resolver phasing is inactive.  
When **b49** is set at 1, resolver phasing is enabled.



**Warning**

**Change the value of b49 only when the Drive is disabled by setting b2 at 0, and the motor is stopped**

<b>b50</b>	<b>Display return function</b>	R-W
0 or 1	Def. val.	0 Res.

When **b50** is set at 0, the control keypad display returns to **rdY** or the speed value after 8 seconds without a key stroke.

When **b50** is set at 1, the display continues to show the value of the last parameter to have been selected.

<b>b51</b>	<b>Serial link data format</b>	R-W
0 or 1	Def. val.	0 Res.

When **b51** is set at 0, 8 data bits with no parity is selected.

When **b51** is set at 1, 7 data bits with even parity is selected.

**Note**

**This parameter can be adjusted only at the keypad, not by using serial communications.**

<b>b52</b>	<b>Serial link mode</b>	R-W
0 or 1	Def. val.	0 Res.

When **b52** is set at 0, ANSI standard is selected.

When **b52** is set at 1, Terminal mode is selected.

<b>b53</b>	<b>Digital stop mode selector</b>	R-W
0 or 1	Def. val.	0 Res.

When **b53** is set at 0, stop and hold is selected.

When **b53** is set at 1, stop, orientate, and hold is selected.

See **Pr27**.

<b>b55</b>	<b>External Trip Alarm</b>	RO
	Def. val.	Res.

**b55** = 0 indicates no external trip.

**b55** = 1 indicates external trip active.



<b>b56</b>	<b>External trip enable</b>	R-W
0 or 1	Def. val. 0	Res.

When **b56** is set at 0, external trip is disabled.  
When **b56** is set at 1, external trip is enabled.

<b>b81</b>	<b>Digital output short circuit trip</b>	RO
	Def. val.	Res.

**b81** = 0 indicates digital outputs are normal.  
**b81** = 1 indicates a digital output is short-circuit to 0V.

<b>b82</b>	<b>DC over-voltage trip</b>	RO
	Def. val.	Res.

**b82** = 0 indicates DC bus voltage below permitted maximum (<808V).  
**b82** = 1 indicates DC bus voltage above permitted maximum (>808V).

<b>b83</b>	<b>DC under-voltage trip</b>	RO
	Def. val.	Res.

**b83** = 0 indicates voltage above permitted minimum (>400V).  
**b83** = 1 indicates voltage below permitted minimum (<400V).  
See **Pr4**.

<b>b84</b>	<b>Over-current trip</b>	RO
	Def. val.	Res.

**b84** = 0 indicates current below the set limit.  
**b84** = 1 indicates current exceeds 110% of  $I_{pk}$ .

<b>b85</b>	<b>Over-temperature trip</b>	RO
	Def. val.	Res.

**b85** = 0 indicates heat-sink temperature below permitted maximum.  
**b85** = 1 indicates heat-sink temperature above permitted maximum.

<b>b86</b>	<b>Resolver break trip</b>	RO
	Def. val.	Res.

**b86** = 0 indicates no fault.  
**b86** = 1 indicates a fault present.

<b>b87</b>	<b>Overspeed trip</b>	RO
	Def. val.	Res.

**b87** = 0 indicates the speed is within limits.  
**b87** = 1 indicates the speed has exceeded the limit set in **Pr58**.

<b>b88</b>	<b>Invert Polarity of STOP signal</b>	R-W
	Def. val. 0	Res.

Set **b88** at 0 for zero speed when terminal B6 is at +24V.  
Set **b88** at 1 for zero speed when terminal B6 is at 0V.

<b>b89</b>	<b>I<sup>2</sup>t integrating alarm</b>	RO
	Def. val.	Res.

**b89** = 0 indicates Drive not in the I<sup>2</sup>t zone.  
**b89** = 1 indicates Drive is in I<sup>2</sup>t limit.

<b>b91</b>	<b>Over-temperature pre-alarm</b>	RO
	Def. val.	Res.

**b91** = 0 indicates heat-sink temperature <75°C (167°F).  
**b91** = 1 indicates heat-sink temperature >75°C (167°F).

<b>b95</b>	<b>Internal braking resistor overload</b>	RO
	Def. val.	Res.

**b95** = 0 indicates Normal.  
**b95** = 1 indicates Overload.

<b>b96</b>	<b>At-speed relative/absolute</b>		R-W
0 or 1	Def. val.	1	Res.

Defines the type of signal given by the At-speed given by the At-speed status parameter **b42**.

When **b96** is set at 0, absolute is selected.

When **b96** is set at 1, relative is selected.

When **b96** is set at 1 (relative) the At-speed status held in **b42** is related to the Speed Reference input, so that **b42** = 1 (At speed) when the motor speed is between the two limits, as follows:

*Greater than* [Speed reference] – **Pr56**

*Less than* [Speed reference] + **Pr57**

When **b96** is set at 0 (Absolute) the At-speed status held in **b42** responds to the absolute values set in **Pr56** and **Pr57**, so that **b42** = 1 (At speed) when the motor speed is between the two limits, as follows:

*Greater than* **Pr56**

*Less than* **Pr57**

Refer also to **Pr56**, **Pr57** and **b42**.

<b>b99</b>	<b>Save RAM to EEPROM</b>		R-W
0 or 1	Def. val.	0	Res.

Saves new parameter values in the EEPROM. The display shows **SAVE** while parameters are being saved. **b99** is related to **b1** and **b5**.

When **b99** is set at 0, no saving occurs.

When **b99** is set at 1, parameters are saved.

## 11.3 Summary of default values

### Variable parameters (R–W)

Parameter	Default	Unit	Name	
Pr0	0	RPM	Digital speed reference	
Pr1	0	RPM	Digital speed reference	
Pr2	0	RPM	Digital speed reference	
Pr3	0	RPM	Digital speed reference	
Pr5	0	V	Auto stop function	
Pr6	0	RPM	Analog reference input offset	
Pr7	1	Hz	Speed loop bandwidth limit	
Pr8	0	% I <sub>pk</sub>	Digital current reference	
Pr9	200	ms	Forward acceleration ramp	
Pr10	200	ms	Reverse acceleration ramp	
Pr11	200	ms	Forward deceleration ramp	
Pr12	200	ms	Reverse deceleration ramp	
Pr13	30		Proportional gain	
Pr14	30		Derivative gain	
Pr15	30		Integral gain	
Pr16	0		Resolver phasing	
Pr19	10.0	s	Digital reference scan time	
Pr20	0		Number of offset pulses	
Pr21	0		Digital reference selector enable	
Pr22	1		Drive address	
Pr23	9600		Baud rate	
Pr25	0		Security code	
Pr27	0		Shaft orientation function	
Pr30	0		Digital output selector 1	
Pr31	1		Digital output selector 0	
Pr37	12		Orientation loop gain	
Pr42	100	% I <sub>pk</sub>	Maximum current limit	
Pr45	50	% I <sub>pk</sub>	Nominal current	
Pr53	10		Shaft orientation window	
Pr54	150	RPM	Speed reference during orientation	
Pr55	7.0	secs	Motor thermal time constant	
Pr56	-5	RPM	Motor at-speed window – lower limit	
Pr57	5	RPM	Motor at-speed window – upper limit	
Pr58	3200	RPM	Maximum speed limit	
Pr68	1		Simulated encoder output resolution	
Pr70	4		Position reference input scaling	
Pr71	0		Position loop integral gain	
Pr75	0		Position reference (via serial comms only)	
Pr76	0		Position reference (via serial comms only)	
Pr95	6		Number of motor poles	
Pr99	3000	RPM	Speed – full-scale	

## Bit parameters (R–W)

Parameter	Default	Effect	Name
b0	0	Disable	Enable change of security code
b1	0	Not	Recall parameter settings from EEPROM
b2	1	Enable	Drive enable
b3	0	Not	Alarm reset
b5	0	Not	Recall default values from EEPROM
b6	0	Speed	Reference selector
b7	0	Disable	Enable ramps
b8	0	Analog	Current reference mode selector
b11	0	Delimit	Current limit selector
b12	0	(b13)	Current signal selector
b13	0	TPRC	Current signal source selector
b14	1	Analog ref.	Reference selector
b15	0	Polarity	Sign signal polarity selector
b16	0	Speed selector	Digital input selector
b17	0	Analog	Speed reference input selector
b18	0	Digital	Digital stop selector
b21	1	Enable	BCC enable
b22	1	Enable	Normal-stop ramp function
b23	1	With	Limit-switch ramp function
b49	0	Inactive	Resolver phasing
b50	0	Return	Display return function
b51	0	8-bit	Serial link (interface) data format (parity)
b52	0	ANSI	Serial link (interface) mode
b53	0	Stop and hold	Digital stop mode selector
b56	0	Disable	External trip (Et) enable
b88	0	+24V = STOP	Invert logic of STOP signal
b96	1	Relative	At-speed relative or absolute
b99	0	Not	Save Working Table to EEPROM

---

## 12 Trip Codes and Fault Finding

---

### 12.1 Trip codes

The last trip code is stored in **Pr98**. The value read from **Pr98** via the serial comms is the trip code number.

**OU**

#### **Trip Code number: 1 Over Voltage**

The DC bus voltage has exceeded the permitted maximum of 808V.

**UU**

#### **Trip Code number: 2 Under Voltage**

The DC bus voltage is below the permitted minimum of 404V.

**OC**

#### **Trip Code number: 3 Over Current**

Excessive current (>110% of  $I_{pk}$ ) has been detected in the output bridge.

**th**

#### **Trip Code number: 4 Over Temperature**

The temperature of the heatsink has exceeded the permitted maximum of 95°C (173°F).

**rb**

#### **Trip Code number: 5 Resolver Break**

One of the connections to the resolver has been lost or broken.

**It**

#### **Trip Code number: 6 I<sup>2</sup>t Current Limitation**

The output current has been in excess of that set in **Pr45** for too long, and the drive is limiting the current to the value set in **Pr45**.

**Note**

**This is NOT a trip condition.**

---

**PA**

#### **Trip Code number: 7 Over Temperature Pre-Alarm**

The heatsink temperature is close to the permitted maximum.

**OS**

#### **Trip Code number: 8 Motor Overspeed**

The motor speed has exceeded the safe limit set in **Pr58**.

**SC**

#### **Trip Code number: 9 Digital Output Short Circuit Trip**

A digital output (terminals B7, B8, B15) is short circuit to 0V.

**Et**

#### **Trip Code number: 10 External Trip**

The external trip input has been activated. If a motor PTC thermistor is connected, the motor is overheating.

**Err**

or

**dOI**

#### **Trip Code number: 11 Hardware Fault Trip or Drive Operating Incorrectly**

There is an internal hardware fault. Remove then re-connect AC power to the Drive. This may clear the fault, otherwise consult the supplier of the Drive.

## 12.2 Fault finding

Condition	Causes	Actions
At power-up, the Drive is enabled but the motor is disabled		
	b2 at 0	Set <b>b2</b> at 1
Analog speed reference $\neq 0$ but motor does not turn and is in torque		
	Hold-zero-speed function active	Check that the input applied to pin <b>B6</b> is 0V and that <b>b18</b> is set at 0.
	Digital ref. selected	Check that <b>b17</b> is set at 0.
Analog speed reference varies but motor rotates at constant speed		
	Digital ref. selected	Check that <b>b17</b> is set at 0.
Motor speed changes with analog reference change, but speed and reference do not correspond		
	Torque control selected	Check that <b>b6</b> is set at 0.
When the Drive is enabled, the motor is in torque at maximum current, and the Drive enters the I <sup>t</sup> region		
	Faulty connections	Check the wiring, especially for inverted phases..
When the Drive is enabled and a speed reference is applied, the motor is at a standstill but free to rotate.		
	No current in motor	Check the current limit (analog or digital) $\neq 0$ . Refer to <b>b11</b> or <b>Pr42</b> , <b>Pr43</b> and <b>Pr45</b> .
Communication with remote terminal not possible.		
	Serial communications programming error	Check Baud rates and data formats correspond. Check polarity of wiring connections.
At power up the Drive displays dEf		
	The User Table of parameters has become corrupted or parameters do not match the version of the software	Set <b>b99</b> at 1. Re-program the parameters and again set <b>b99</b> at 1. <b>Model sizes 1 and 2</b> If <b>dEf</b> re-appears when AC power is next applied, change the Control Keypad. <b>Model size 34</b> If <b>dEf</b> re-appears when AC power is next applied, change the NOVRAM on the control board.

# 13 Serial Communications

## 13.1 Introduction

Serial communications can be used by a host computer or PLC to read and edit parameters, and control any function on the Drive. The serial communications port is an RS422/RS485 specification, and allows the host to communicate with up to 32 Drives on a single line. The protocol is industry standard ANSI x 3.28–2.5–A4

## 13.2 Connecting the Drive

### RS485 and RS422

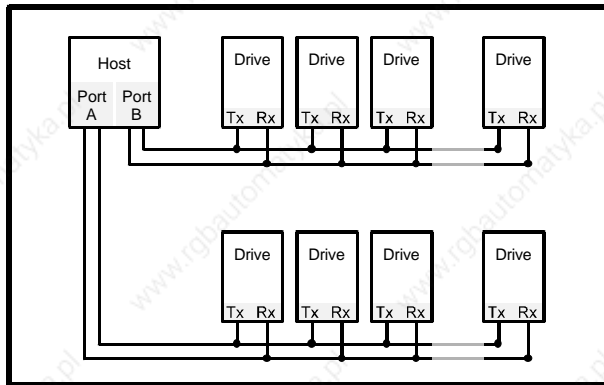
RS485 uses 4-wire differential lines which ensure a high level of immunity to noise. It also has high common-mode rejection.

RS485 full-duplex four-wire connection allows multi-drop links to be made to a maximum of 32 Drives. See Figure 13–1. The maximum permissible cable length for each link is 1200m (3700 feet).

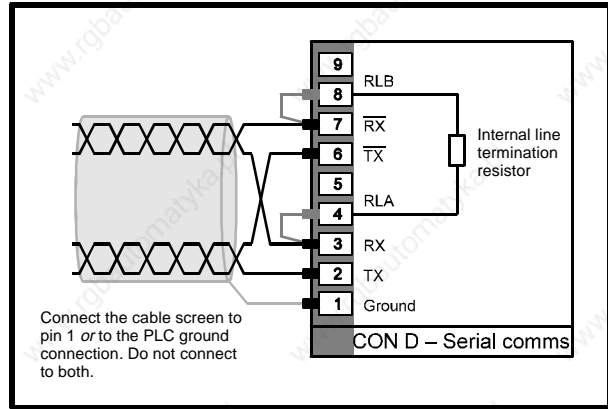
On the final Drive in each serial communications link, connect the following pins in order to terminate the receive line with the internal line termination resistor:

Pin 8 to pin 7

Pin 4 to pin 3



**Figure 13–1 Up to 32 Drives can be connected to each communications port of the host computer**



**Figure 13–2 Connections for 4-wire RS485 or RS422 serial communications**

## 13.3 Serial communications connector

Pin No.	Function	Description
D1	GND	Ground
D2	TX	Transmit
D3	RX	Receive
D4	RLA	Network terminating resistor
D5	FREQOUT	Frequency output
D6	$\overline{\text{TX}}$	Transmit (inverting)
D7	$\overline{\text{RX}}$	Receive (inverting)
D8	RLB	Network terminating resistor
D9	DIROUT	Direction output

## 13.4 Serial communications configuration

The configuration for the serial port must be determined before attempting to communicate with the Drive. These parameters should be set up using the control keypad.

### Baud rate

The Baud rate is selected using parameter **Pr23**. The selected rate must be the same as that of the host computer.

## Data format

The data field format is selected using parameter **b51**.

### 7-bit plus parity (bit 51 = 0)

- One start-bit
- Seven data bits
- One even parity bit
- One stop bit

### 8-bit, no parity (bit 51 = 1)

- One start bit
- Eight data bits
- One stop bit

## 13.5 Message structure

Serial messages consist of the following:

- Control characters
- Serial address code
- Parameter identifier
- Data field
- Block checksum (BCC)

### Control characters

If a message is initiated from a keyboard, control characters may be entered by holding down the CTRL key and pressing the key shown in the table below.

Character	Purpose	ASCII code (HEX)	CTRL + key
EOT	Reset Message begins	04	D
ENQ	Enquiry Interrogating the Drive	05	E
STX	Start of text	02	B
ETX	End of text	03	C
ACK	Acknowledge (go to next parameter)	06	F
BS	Backspace (go to previous parameter)	08	H
NAK	Negative acknowledge (repeat same parameter)	15	U
CR	Carriage return	0D	M

## Serial address code

Each Drive on a serial link must have a unique address. This allows the host controller to communicate with each Drive individually. The Drive address code is entered in Pr22, and can be any value between 1 and 32. (Drive address 00 has a special use, see below) Each digit of the address is transmitted twice, so to address Drive 08, the following must be transmitted:

Drive address			
0	0	8	8

It is possible to send an instruction to all Drives on the serial link using Drive address 00. All Drives will listen to the an instruction, but none will acknowledge. This can be useful for ensuring that all Drives on a flow line get the START signal at the same instant.

### Parameter identifier

To address an individual parameter, the host must send a code that relates to that parameter. There are two types of parameter in the DigitAx:

Numerical parameters      **Pr00 to Pr99**  
Parameter identity  
000 to 099

Bit parameters              **b00 to b99**  
Parameter identity  
100 to 199

### Data field

Data is sent as a numerical value with sign and decimal point. The data field can consist of up to six characters, two of which must be the sign and decimal point. The data field can be shortened when transmitting data to the Drive, since the ETX control character (see above) indicates the data is complete. The response of the Drive, when interrogated, will always have six data characters.

### Block checksum

The block checksum character (BCC) is used to check the received message has not been corrupted during transmission. The BCC is a value that is calculated from the ASCII codes of the characters in the parameter identifier and data fields. The BCC is calculated by using the XOR function, and starts with the first character following the STX (ctrl B) control character. The following example shows how to calculate the BCC.



The instruction is to change the value of **Pr06** to -35.8.

Character	ASCII code	XOR
0	011 0000	
0	011 0000	000 0000
6	011 0110	011 0110
-	010 1101	001 1011
0	011 0000	010 1011
3	011 0011	001 1000
5	011 0101	010 1101
.	010 1110	000 0011
8	011 1000	011 1011
ETX	000 0011	011 1000
8	011 1000	

#### Note

**If the calculated value for the BCC is less than 32 decimal, (20Hex) then 32 must be added. The resulting character is used as the BCC value.**

**The BCC can be disabled by setting bit 21 = 0, but a CR (ctrl M, 0DHex) character MUST be transmitted in place of the BCC character.**

## 13.6 Messages from host to Drive

### Interrogate the Drive

To find the value of a parameter, the host must send a message in the format shown below. No data field is needed.

	Drive address	Pr	
EOT	0 0 1 1	0 0 6	ENQ
Ctrl-D			Ctrl-E

The response from the Drive will be in the format shown below. The data field will always consist of six characters.

	Pr	Data field		BCC
STX	0 0 6	- 0 3 5 . 8	ETX	8
Ctrl-B			Ctrl-C	

If a parameter interrogated does not exist, the Drive will reply with the message:

	Pr	
STX	0 2 8	EOT
Ctrl-C		Ctrl-D

Once a Drive has been interrogated, it is possible to extract data from the Drive using the quick commands, without needing to address the Drive each time.

### NAK

#### Repeat last response

The Drive will repeat the data for the same parameter. This provides a quick way of monitoring a continuously changing parameter.

### ACK

#### Read next parameter

The Drive will respond with the data for the next higher parameter number.

### BS

#### Read previous parameter

The Drive will respond with the data for next lower parameter number.

## 13.7 Write data to the Drive

To write data into the Drive, the message must be in the format shown below. The data field does not need to be six characters long, since the ETX (ctrl C) character indicates the end of the data. The BCC can be disabled, but a CR (ctrl M) character **must** be transmitted in its place.

	Drive address	Pr	Data field		BCC
EOT	0 0 1 1	STX	0 0 6 - 0 3 5 . 8	ETX	8
Ctrl-B		Ctrl-B		Ctrl-C	

The Drive will respond with either of the following:

### ACK

Message received, understood and carried out.

### NAK

Message received, but not carried out. The data is out of range, or the message was corrupted during transmission. The EOT character and Drive address can be omitted from subsequent write instructions to that Drive.

## 13.8 Terminal mode

Terminal mode uses a simplified protocol. To communicate with Drive address 02, the terminal must be opened using the selection string. This is done by transmitting the following message:

	Drive address				
EOT	0	0	2	2	Cr
Ctrl-D					Ctrl-M

The Drive responds with:

0	2	>
---	---	---

The terminal remains in open communication with this Drive until a different selection string is sent.

### Interrogating the Drive

To interrogate the Drive, e.g. to find the value of parameter **Pr6**, the message sent would be:

Pr	
P 6 =	CR
	Ctrl M

For bit parameter **b24**, the message would be:

	Pr		
P	1 2 4 =		CR
			Ctrl M

### Sending commands to the Drive

To send a command to the Drive, the string is composed of the same characters but with the new value inserted after the = sign, as follows:

Pr	Data field	
P 6 =	- 0 3 5 . 8	CR
		Ctrl-M

## Quick keystrokes

### ESC

Resets the current command line, clearing it of entered information

=

Requests a repeat of the data for the parameter last addressed

>

Requests the data for the parameter of next higher number

<

Requests the data for the parameter of next lower number

### Errors

Plain language error messages are returned in Terminal Mode as follows:

#### Parameter not recognised

Message string does not comply with format.

#### Parameter not recognised

A number has been given in the Address field which does not apply to any parameter.

#### Value out of range

Value sent is above or below the maximum or minimum value permissible for the parameter addressed.

#### Too many characters

Up to 20 characters are permitted in Terminal Mode.

#### Read-Only Parameter

An attempt has been made to write to a read-only (OR) parameter.

## 13.9 Parameters related to serial communications

Number	Type	Name and description	Range	Resolution	Default
Pr22	R/W	Drive Address	1 to 32	1	1
Pr23	R/W	Baud Rate This parameter can be set only at the control keypad, not by the host computer. Adjust the value to the Baud rate of the host computer	300, 600, 1200, 2400, 4800, 9600, 19200.		9600

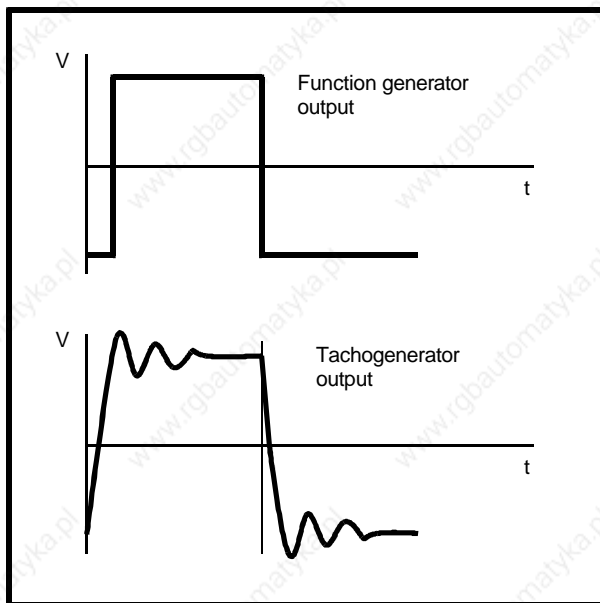
Number	Type	Name and description	Default	Default Status
b21	R/W	BCC enable When b21 is set at 0, BCC is disabled When b21 is set at 1, BCC is enabled	1	Enabled
b51	R/W	Data format When b51 is set at 0, 8 data bits, no parity is selected When b51 is set at 1, 7 data bits, even parity is selected This parameter can be set only at the control keypad, not by the host computer.	0	8 bits no parity
b52	R/W	Serial communications mode When b52 is set at 0, ANSI standard is selected When b52 is set at 1, Terminal mode is selected	0	ANSI mode



## A PID Loop

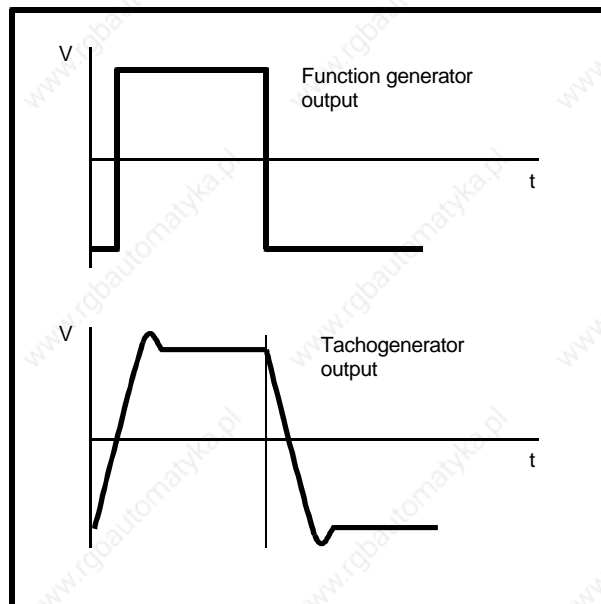
### A.1 Setting the PID gains

1. Apply +24V to terminal **B14** and set **b2** at **1** to enable the Drive.
2. Check the waveform on the oscilloscope. If the waveform is similar to that shown in Figure A-1 the proportional gain is too low.

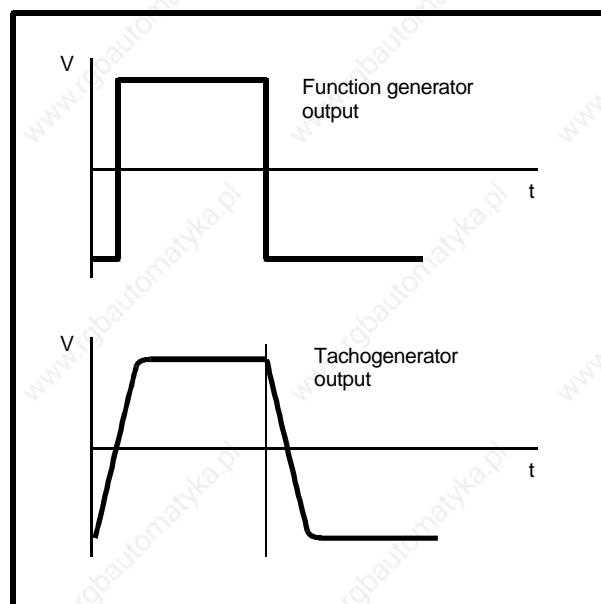


**Figure A-1** Waveform resulting from proportional gain being too low

Increasing the value of **Pr13** (proportional gain) will achieve a waveform similar to that shown in Figure A-2, which shows low derivative gain. Increasing the value of **Pr14** (derivative gain) will reduce overshoot at the expense of increased current and possibly increased heating of the motor. An ideal response can be achieved as shown in Figure A-3.



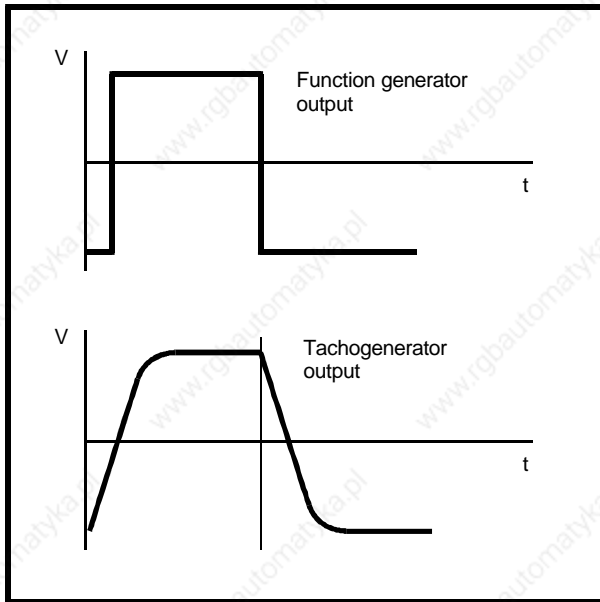
**Figure A-2** Waveform resulting from derivative gain being too low



**Figure A-3** Waveform showing ideal response

Excessive derivative gain can have the following effects:

- Excessive heating of the motor due to extra current
- Motor shaft oscillation
- I2t current limiting
- Reduced speed of response as shown in Figure A-4



**Figure A-4** Reduced speed of response caused by excessive derivative gain

**Pr15** (integral gain) is not likely to require adjustment. If adjustment is required, the value must not exceed 250. If stability of position control or anomalous responses to stop signals persist, check the operation of the position controller.

## A.2 Evaluating the PID gains

The following guide is based on a combination of theoretical analysis and practical experience. The results obtained may not always give the optimum performance but will give a useful starting point for the settings required for the speed loop gains.

### Evaluating the integral gain

It is possible to calculate the required value of parameter **Pr15** *Integral gain* from the required acceleration and the stiffness of the system. The acceleration can be calculated from:

$$\alpha = \frac{I_{pk} \times K_T}{J}$$

Where:

$I_{pk}$  = Peak current of the drive (A)

$K_T$  = Motor torque constant (N.m/A)

$J$  = Total inertia of the motor and load (kg.m<sup>2</sup>)

The stiffness can be expressed as degrees of angle that the motor shaft rotates in order to deliver full torque when the torque reference is zero. For systems requiring a stiff response, the angle would be around 6°. For a softer response, the angle may be up to 60°.

The required value of parameter **Pr15** can then be calculated from:

$$\text{Pr 15} = \frac{1.5 \times \sqrt{\alpha}}{\phi}$$

Where:

$\phi$  = Stiffness angle in degrees

### Evaluating the proportional gain

The value of parameter **Pr13** *Proportional gain* can be calculated as follows:

$$\text{Pr 13} = \frac{\left( \frac{I_{nom}}{I_{pk}} \right) \times 22\,500}{\phi \times (\text{Pr 15} + 1)}$$

Where:

$I_{nom}$  = Nominal current

$I_{pk}$  = Peak current

### Evaluating the derivative gain

The value of parameter **Pr14** *Derivative gain* can be calculated as follows:

$$\text{Pr 14} = \frac{512 \times \sqrt{2}}{\text{Pr 15} + 1}$$

This results in a damping factor of 0.7.

For low values of acceleration and/or large stiffness angles the theoretical value may exceed the range of **Pr14**. In this case it is necessary to set **Pr14** at 0.

The minimum (non-zero) value of **Pr14** that gives stable operation is as follows:

$$\frac{512}{\text{Pr 15} + 1}$$

## A.3 Setting the bandwidth limit

The bandwidth limit of the speed loop can be adjusted from 20Hz to 320Hz using parameter **Pr7**.

The bandwidth limit has the effect of a first-order filter which can be used to eliminate mechanical resonance and reduce audible noise. Refer to **Pr7** in Chapter 11 *List of Parameters*.