



# HPD N

(HPD2N, HPD5N, HPD8N, HPD16N,  
HPD20N,HPD24N)

User's manual

rev. 8.5  
November 2004  
software rel. 41

# HPD

## HIGH PERFORMANCE DRIVE

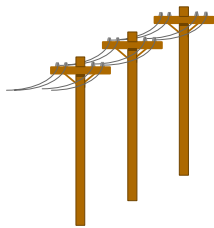
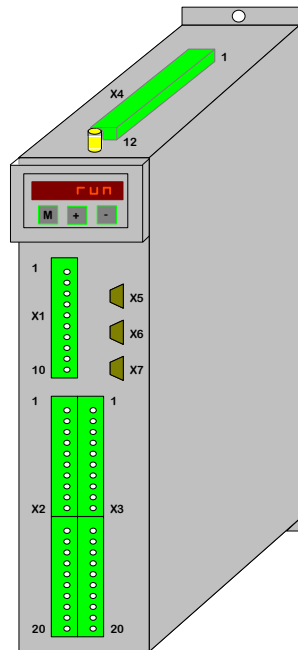

RS-485 or RS-422 SERIAL LINK

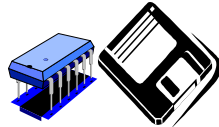

SOFTWARE & HARDWARE  
EXPANSION

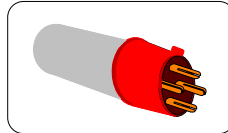

EXTENDED  
VOLTAGE RANGE

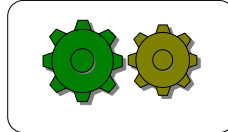

DIGITAL-LOCK  
VARIABLE RATIO

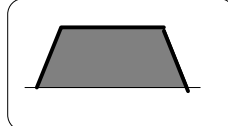

POSITIONER



STEP MOTOR  
SIMULATION



EASY  
MAINTENANCE

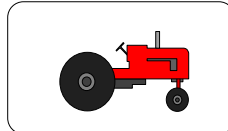

TORQUE CONTROL



ACCELERATION  
CONTROL

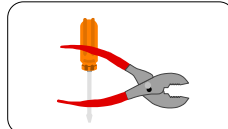

SPINDLE ORIENTATION  
FOR TOOL CHANGING

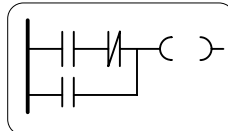

BUILT-IN P.L.C.

**Parker Hannifin S.p.A.**

**Divisione S.B.C.**

Via Gounod, 1 – 20092 Cinisello B.  
(Milano) – Italy

Phone: +39-02-66012478

Fax: +39-02-66012808

E-mail: [drivesbc@parker.com](mailto:drivesbc@parker.com)

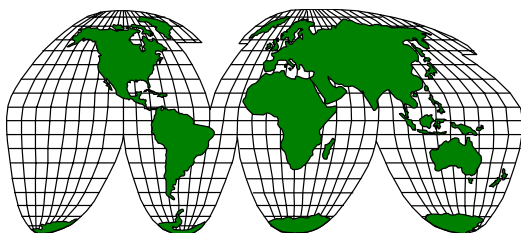

***HPD :***  
***everywhere***  
***for any***  
***application***





Parker Hannifin S.p.A.  
Divisione S.B.C.  
Via Gounod, 1 – Tel.02 66012459  
20092 Cinisello Balsamo (MI) – Italy

COMPANY  
WITH QUALITY SYSTEM  
CERTIFIED BY DNV  
ISO 9001/2000

## DICHIARAZIONE DI CONFORMITÀ CE CE DECLARATION OF CONFORMITY

Dichiarazione N. **DC007-R 0.0**  
*Declaration N.*

Costruttore **PARKER HANNIFIN S.p.A. – Divisione S.B.C.**  
*Manufacturer*

Indirizzo **Via Gounod, 1**  
*Address* **20092 Cinisello Balsamo (MI)**  
**ITALIA**

Prodotto **Azionamento**  
*Product* **Drive**

Nome del Prodotto **HPD2N, HPD5N, HPD8N, HPD16N,HPD 20N,HPD24N**  
*Product name*

Il prodotto sopra descritto è conforme a:  
*The above product is conform to:*

Doc. N. / Doc. Nr.	Titolo / Title	Edizione / Edition
CEI EN 60065	Apparecchi audio, video ed apparecchi elettronici similari- Requisiti di sicurezza. Audio, video and similar electronic apparatus - Safety requirements.	8a / 6768 Gennaio 2003
CEI EN 50178	Apparecchiature elettroniche da utilizzare negli impianti di potenza. Electronic equipment for use in power installations	1a/5080 Marzo 1999
CEI EN 61000-6-2	Compatibilità elettromagnetica Parte 6-2: Norme Generiche – Immunità per gli ambienti industriali. Electromagnetic compatibility 6-2: Generic Standards- Immunity for industrial environments	2a / 6671 Ott.2002
CEI EN 61000-6-4	Compatibilità elettromagnetica Parte 6-4: Norme generiche – Emissioni per gli ambienti industriali. Electromagnetic compatibility 6-4: Generic Standards- Emission standard for industrial environments	1a / 6673 Ott.2002
CEI EN 61800-3 e /A11	Azionamenti elettrici a velocità variabile. Parte 3:Norma di prodotto relativa alla compatibilità elettromagnetica ed ai metodi di prova specifici. Adjustable speed electrical power drive systems Part 3: EMC product standard including specific test methods.	1a / 2861 Settembre 1996 5805 Ottobre 2000
CEI EN 60204-1	Sicurezza del macchinario Equipaggiamento elettrico delle macchine, Parte 1: Regole Generali Safety of machinery – Electrical equipment of machines, Part1: General requirements	3a/4455 Aprile 1998

### Note/notes:

I prodotti devono essere installati seguendo scrupolosamente le indicazioni riportate nel manuale d'uso e manutenzione.  
*These products must be installed scrupulously following the instructions written on the handbook.*

I prodotti inclusi sono conformi ai requisiti della Direttiva 73/23/CEE modificata dalla 93/68/CEE, e alla Direttiva 89/336/CEE.  
*These products are corresponding to the 73/23/CEE requirements guideline, modified by 93/68/CEE and 89/336/CEE guidelines.*

Cinisello Balsamo, 05/06/2003

Ottorino SALVALAI, Direttore Generale (General Manager)

Parker Hannifin S.p.A.  
Divisione S.B.C.



Certain circuits in the **HPD** drive carry dangerously high voltages that could cause serious personal injury or death.

**Do not attempt to service any parts of the drive when it is connected to the power supply.**

If you need to access internal parts, before working on the drive allow at least 15 minutes after power-down to allow the DC bus capacitors to discharge. It is the User's responsibility to make sure that the installation is executed in accordance with established industrial health and safety standards.

In relation to the interpretation of standards, note that the drive is considered as a component and not as a machine.

Any tampering or unauthorised modification of the drive will invalidate the guarantee immediately. Guarantee cover is otherwise provided for 1 (one) year.

This instruction manual is applicable to the standard version of the drive.

Parker Hannifin S.p.A. - S.B.C. Division declines all liability for any whatsoever form of damage caused by inappropriate use of the drive.

**Installation and maintenance of the drive and connected equipment must be performed exclusively by qualified and trained personnel with basic skills in electronics.**

**Commissioning of the drive must be performed exclusively by qualified and trained personnel with advanced skills in electronics and drive technology.**

Training courses can be supplied by Parker Hannifin S.p.A. - S.B.C. Division on request.

**The quoted performance of the HPD drive is guaranteed only when used with series MB synchronous motors manufactured by Parker Hannifin S.p.A. - S.B.C. Division**

## CONTENTS:

1. INTRODUCTION.....	5
1.1. General information .....	5
1.2. Product description.....	5
1.3. Direct mains connection.....	6
1.4. Identification .....	6
2. Technical data .....	7
2.1. Main hardware specifications.....	7
2.2. Software features.....	8
2.3. Compliance with EMC standards.....	8
2.4. Safety.....	8
3. INSTALLATION.....	9
3.1. Safety instructions .....	9
3.2. Interference suppression hints .....	10
3.3. Mains filter installation instructions.....	10
3.4. Control cubicle layout example.....	12
3.5. HPD drive mains filters.....	13
3.6. Terminal assignments.....	16
3.7. Power connections.....	18
3.8. Power connection layout .....	19
3.9. Signal cable connections .....	20
3.10. Signal cable connection layout.....	20
3.11. Frequency input connection .....	20
3.11.1. Encoder emulation.....	23
3.12. Serial line connection .....	23
3.13. Braking resistor .....	24
3.14. Backup.....	24
4. PARAMETERS AND PROGRAMMING .....	25
4.1. Using the keypad.....	26
4.2. Commissioning the HPD drive .....	27
4.3. Basic parameters .....	30
4.4. Basic commands.....	36
4.5. Calibrating speed loop.....	37
4.6. Operating modes .....	43
4.6.1. Torque control .....	43
4.6.2. Acceleration control .....	43
4.6.3. Low voltage procedure (rel. Sw.41 or more) .....	44
4.6.4. Maintenance and commissioning.....	45
4.6.5. Positioner.....	46
4.6.6. Digital locking.....	48
4.6.7. Stepper motor emulation .....	49
4.6.8. Spindle orientation .....	51
4.7. Block diagrams.....	51
4.8. Digital input and output programming.....	58
4.8.1. Pico-PLC .....	58
4.8.2. Examples and applications .....	63
4.9. Programming with Pbrush.....	80
5. SERIAL INTERFACE.....	81

5.1.	Communication protocol.....	81
5.2.	Serial addresses and parameter lengths.....	87
6.	Appendix A: HPD drive mechanical dimensions .....	89
7.	Appendix B: hardware characteristics.....	90
8.	Appendix C: DC bus voltage thresholds .....	91
9.	Appendix D: Standard settings.....	91
10.	Appendix E: Software timers .....	92
11.	Appendix F: pico-PLC default program.....	93
12.	Appendix G: flash information .....	94
13.	Appendix H: Alarms .....	95
14.	Appendix I:options.....	97
15.	Appendix L: EC4 .....	98
15.1.	Product description.....	98
15.2.	Main characteristics.....	98
15.3.	EC-4 block diagram .....	99
15.4.	Product and connectors identification .....	100
15.5.	EC-4 installation.....	101
16.	Profibus-DP connector .....	102
17.	Can Bus Connector.....	103
18.	Digital I/O .....	104
19.	Encoder and serial link.....	106
20.	Motion functions concepts .....	108
21.	Examples of applications .....	109
21.1.	Power supply for presses.....	109
21.2.	Electronic cam.....	110
21.3.	Positioner with 250 preset levels.....	111
21.4.	Two-axis extractor.....	112
21.5.	Vertical robot.....	113
21.6.	Continuous press .....	114
21.7.	On the fly cutting.....	115
21.8.	Heat sealer .....	116
22.	Appendix M: external bracking modul .....	117
23.	Appendix N application description form.....	119
24.	Rerersion history of the User's Manual .....	121

## 1. INTRODUCTION

### 1.1. General information

This manual describes operations required for the installation and commissioning of the HPD (High Performance drive) drive for brushless motors. Read all chapters of the manual carefully before using the drive.

**Peerlessness with previous versions: if you wire together the DC BUSES, the drive must be of the same family (HPD with HPD, HPD N with HPD N - not HPD with HPD N ! Pay attention when ordering a spare part !).**

Except the above situation, the HPD N can replace a HPD drive.

**When using the backup feature, DO NOT change the HPD N with the HPD: the circuitry is different and the HPD requires the external relay.**

### 1.2. Product description

The HPD drive is a digital frequency converter for driving AC brushless motors. The adoption of a Parametric Operator Interface makes drive configuration procedures faster and easier to repeat. The large number of configuration possibilities makes the drive suitable for numerous applications.

A high power 16 bit micro-controller allows speed control with the characteristics required of a servo controller, plus a range of auxiliary functions that can help reduce the presence of control electronics in the application and thus permit considerable economic savings.

In addition to the positioner functions with trapezoidal profile, digital lock, spindle orientation, stepper motor emulation, torque control and acceleration control, the HPD drive also has an internal pico-PLC. The pico-PLC adopts the most diffused industrial programming standards and offers considerable freedom for use of inputs and outputs. It also enables users to develop a range of additional functions that are not among the basic features of the drive.

The HPD drive is complete with an RS-422/RS-485 serial interface which can be used for configuration, monitoring, or simultaneous transmission of commands to a multiple system comprising up to 32 HPD drives.

In addition to the above functionality, the HPD drive is designed as an open system with the facility to accommodate hardware and software expansion cards. For further information on currently available expansion cards contact Parker Hannifin S.p.A. - S.B.C. Division directly or your local Dealer.



### 1.3. Direct mains connection

The HPD series of drives is specifically designed for direct connection to a three-phase mains power supply from 90 to 460V~ 50/60 Hz, without interposing transformers. It is the responsibility of the User to connect the system via protection fuses. The use of single phase power supplies is permitted although motor power output must be derated in this case. Maximum motor power is calculated by the following formula:

$$P_{max} = 14 \cdot 10^{-3} V_{rete}^2 \text{ [watt] } \quad \text{only HPD2}$$

$$P_{max} = 27 \cdot 10^{-3} V_{rete}^2 \text{ [watt] } \quad \text{only HPD5 and HPD8}$$

**Not applicable HPD16 HPD20 HPD24**

All protections required for safety, such as overvoltage detection, short circuit fault protection and inverter and motor overtemperature detection are integral with the drive.

Mains filters and motor filters must be calculated during the design of the electrical cubicle so that EMC standards are met in order to qualify for CE marking.

Chapter 2 provides a detailed view of problems related to EMC.

**N.B. leave at least 60 sec. after switching the drive off before switching it on again.**

The HPD “N” has 2.5 seconds circa of power-on time. Previously, it was nearly 10 seconds.

### 1.4. Identification

HPD drives are available in 6 models: HPD2N, HPD5N, HPD8N, HPD16N, HPD20N and HPD25N. The number that follows HPD is the value of drive rated current in amperes.

Parker Hannifin S.p.A. Divisione S.B.C. Via Gounod 1 – 20092 Cinisello B. (Milano) – Italy	
POWER INPUT  3XAC90...480V XXA 50...60 Hz  REINSTALLATION INSTRUCTION MANUAL BEFORE INSTALLING	POWER OUTPUT  3XAC90...480 XXA 0...500 Hz  USE COPPER WIRE RATED 60/75°C

Another yellow warning label is placed on the right side of the HPD “N” drive:



## 2. Technical data

### 2.1. Main hardware specifications

The maximum voltage value is 480Vac (instead of former 460Vac). Ensure that the maximum voltage across terminals L1, L2, L3 does not exceed more than 10% the 480Vac, even in the worst case (see EN60204-1 standard, section 4.3.1). An excessive voltage may damage the drive. The following table describes the new ratings:

<i>Description</i>	<i>Unit</i>	<i>Value</i>					
Mains voltage	V~	90...480					
Models		HPD2N	HPD5N	HPD8N	HPD16N	HPD20N	HPD24N
Rated current	A	2	5	8	16	20	25
Peak current (4 seconds)	A	4	10	16	32	65	50
Input current	FLA	1.6	4.2	6.2	12	15	19
Rated motor torque (@400 V~)	KW	1	2.5	4.1	8.3	10	12.5
Control-stage power dissipation	W	18					
Power-stage dissipation	W	25	60	89	158	200	246
Environmental temperature	°C	45					
Braking resistor		internal / external					
Internal braking resistor power dissipation	W	120				240	
Feedback		resolver (speed 1)					
Power-stage switching frequency	KHz	8					
Max. output frequency	Hz	450					
Protection Grade		IP 20					
Digital Inputs 24V =	N°	8					
Digital Outputs 24V = / 100mA / PNP	N°	6					
Digital Output "Voltage-Free"	N°	1					
Encoder Simulation RS-422	steps/rev	128..16384					
Frequency/sign Input or ext. Encoder	KHz	800 / 200					
Analogue reference	V	±10 diff 15 bits					
Aux. Analogue Input	V	±10 diff 10 bits					
Aux. Analogue Output	V	±10 - 8 bits					
Tacho Output	V	±10 V					
Serial link		RS-422 / RS-485					
Encoder Simulation Backup	V	24 =					
Encoder Simulation Backup	A	max. 2					

## 2.2. Software features

The following capabilities are implemented in the basic software supplied with the HPD drive:

- Speed control
- Advanced torque limit manager
- Speed windows management
- Positioning with trapezoidal speed profile
- Digital locking functions with variable transmission ratio and phase shifting
- Spindle orientation
- Stepper motor emulation
- Torque control with overlaid speed control
- Acceleration ramp control with overlaid speed control
- Simplified maintenance and start-up mode
- Internal PLC for advanced input/output programming functions

## 2.3. Compliance with EMC standards

Immunity:

EN50082-1* / EN61000-6-2		Basic immunity specifications
IEC1000-4-2 (ex IEC 801-2)	level 3	Electrostatic discharge immunity
IEC1000-4-3 (ex IEC 801-3)	level 3	Electromagnetic field immunity
IEC1000-4-4 (ex IEC 801-4)	level 4	Fast transient burst conducted immunity

Compatibility:

EN50081-1* / EN61000-6-4	Basic radio interference specifications
EN55011 group 1, class A	Measurement limits for radio interference
EN55011 group 1, class B*	Measurement limits for radio interference

## 2.4. Safety

Safety standard	EN60065
Low voltage Directive	73/23/CEE amended by 93/68/CEE
Applied standard	EN60204-1
Available with markcULus	UL508C

\* Conformity for use in domestic or industrial surroundings depends on the nature of the installation.

This is a product of the restricted sales distribution class according to EN61800-3.

In a domestic environment this product may cause radio interference, in that case the user must use the properly measures.

### 3. INSTALLATION

- The HPD drive must be installed in a vertical position (power terminal block X4 at the top).
- Leave **at least** 190 mm clearance above and below the drive.

#### 3.1. Safety instructions

- Make sure the drive is correctly sized for the motor you intend to connect. Compare rated voltage and current.
- Wire up electrical panel/drive/motor in accordance with the instructions in this section of the manual, taking into consideration EMC requirements and established safety legislation.
- The User is responsible for installing fuses on the drive A.C. power supply.
- A differential interrupter could not be used on the entry of feeding of the converter. The protection against indirect contacts must be realized through other streets, for instance through a overcurrent disconnecting switch in accord to the EN 50178/ 1994 Sez. 5.3.2.3 and to the EN 60204-1 Sez. 6.3 6.3.1 6.3.2 6.3.3 and however in accord to the laws of the country of installation.
- Before feed the converter, all the components and the motor must be to earth or connected to the points of earth through isolated cables.

**The current of loss toward earth is superior at 3,5mA o'clock. E' therefore application an excellent connection of earth (EN 50178/ 1994 [sez]. 5.12.11.1).**

- Power conductors and control circuits must be kept apart (at least 20 cm) and, when they must cross, intersections must be at a right angle. Motor lines and mains power lines must never be parallel.
- All power conductors must be sufficiently sized (refer to table in heading 2.7; in all cases compliance with IEC227-2 must be guaranteed).
- Conductors connected to the system by means of the terminal strip must not be soldered (EN60065, art.15.3.5).
- Make sure drive and motor and properly earthed.
- Make sure that the maximum voltage on terminals L1, L2, L3 does not exceed rated voltage by more than 10% in the worst possible case (see EN60204-1, section 4.3.1). Excessively high mains feeding voltage can damage the drive.
- Do not detach electrical connections when the drive is connected to the power supply.
- Follow all installation instructions in this manual step by step. If you are in doubt, contact S.B.C. customer service.
- Dangerous voltages may remain for 60 seconds after mains disconnection and system power-down; do not touch power cables during this interval.
- Do not open the drive casing. This action is potentially dangerous and will automatically invalidate the guarantee.

Installation and wiring must be carried out with the entire electrical panel disconnected from the power supply. Make sure that the drive enable command is disconnected from the emergency circuit. Qualified technical personnel must preside when the power panel is powered up for the first time.

### ***3.2. Interference suppression hints***

Because of the high speed voltage wavefronts in PWM, high levels of stray current may sometimes flow through capacitive couplings and earth systems. Stray currents of this type can affect other functional units. It is therefore prudent to calculate the presence of an amount of spurious energy that depends on the size of the system (drives, motor lines, motor). Spurious energy generates EM radiation that can interfere with the operation of nearby systems. Existing standards do not set down limits for this type of radiation.

#### **Preventive measures**

Basic methods for preventing interference are: decoupling of drive from its surroundings, high quality and properly sized conductors to neutralise voltages (earthing), and adequate shielding. Shields, filters and drives must have a large contact area to achieve the maximum possible decoupling and hence optimal noise suppression. Attention must be paid, however, to the entire installation, as this is one of the most important precautions in assuring efficient noise suppression.

High frequency interference takes the form of radiation, especially from the motor lines. This effect can be reduced with the use of shielding.

Another essential counter-measure for noise suppression is the use of filters.

The use of filters is aimed at reducing conducted interference on wiring and the return of conducted interference to source (drive) through routes offering the lowest impedance. This method provides effective protection for other systems connected to the same electrical line, also protecting the drive from interference originating from other systems. When installing filters consider the mains input and motor feeding output; the motor feeding output can be protected with output filters that minimise interference levels (generally toroidal ferrite core coils bearing several windings of all three motor wires).

### ***3.3. Mains filter installation instructions***

To guarantee electromagnetic compatibility in compliance with the relevant standards the maximum priority must be awarded to EMC requirements when designing the control cubicle. To obtain the best results from filters follow the instructions in this section carefully, because

**even a complex and expensive filter is ineffective unless it is installed taking EMC aspects into consideration.**

**Avoid:**

- routing noise emitting cables parallel to “clean” cables
- parallel cables, especially in the vicinity of the filter (ensure physical separation)
- cable loops (keep cables as short as possible and close to the common potential).

**Additional measures**

- With the exception of mains cables to the filter, all power and control wiring must be shielded and, wherever possible, kept segregated (minimum distance 20 cm). If control and power cables must cross, the intersection must be at a right angle.

- Shielded cables must be installed on a copper bar by means of a high conductivity wire clamp. The area of contact must be as large as possible and the shield must be unbroken. In general the shield should be connected at each extremity. In certain circumstances, however, control cable shields may be connected only at one end to eliminate mains hum that could interfere with the control signal. Decide case by case as numerous factors must be considered. Adopt the following general approach: if the shield is solely for shielding, connect at both ends. If current flowing in the shield interferes with the shielded signals, connect at one end only.

- The incoming cable must be connected to an earth terminal by means of a screw to ensure proper contact between shield and earth.

- RF interference suppression filters must be installed as close as possible to the drive and must have a large area of contact with the power panel or the baseplate. Remove all paint. The filter earth terminal must be connected to the earth bar along the shortest possible route.

- As far as possible keep the power side (drive) and control side (PLC or NC) physically separated by separating the metal mounting plates. Do not route any cables through the mounting plates.

**Protective measures for drives with > 3.5mA dispersion current per phase**

Interference currents dispersed through the earth system may be considerable in certain conditions. Therefore, make sure all suppression filters are properly earthed before they are connected. Cable sizes must be in line with the requirements of safety standards.

If a suppression filter is permanently connected and current dispersion during normal operation is greater than 3.5mA (which would be expected with most drives) adopt one of the following measures additionally:

- a) Increase shield size to at least 10 mm<sup>2</sup>.
- b) Install a detection system to monitor the shield and automatically disconnect the drive in the presence of faults.
- c) Install a second conductor in parallel (electrically) with the shield using separate terminals.

**3.4. Control cubicle layout example**

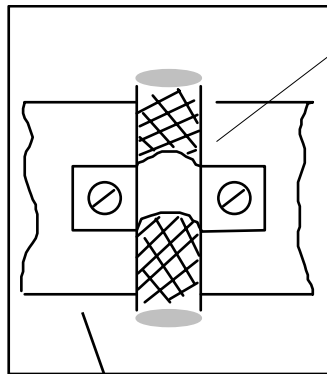

All conductors down-line of the mains filter must be shielded and mounted to a copper bar with large contact area. Also the copper bar must present an ample area of contact with the cubicle mounting plate.

Large surface area partition shield with generous contact area around perimeter. Remove paint from contact points in the cubicle.

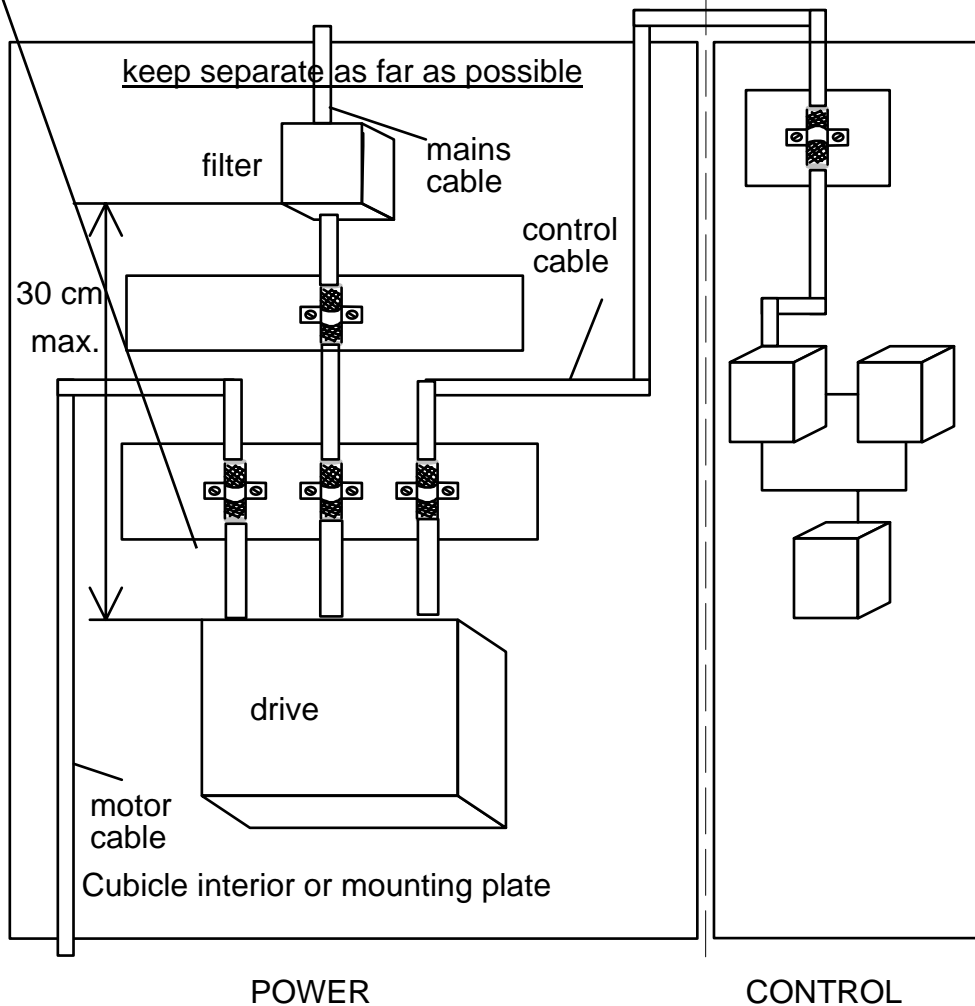

### 3.5. HPD drive mains filters

S.B.C. has developed a special series of filters for HPD drives. When the filters are installed in accordance with our instructions, compliance with EN55011-class A is guaranteed; for class B rating add a transformer to the power supply (shielded primary and secondary). Users must allow space in the control cubicle to accommodate filters implemented at the time of the project. Parker Hannifin S.B.C. division filters provide both mains and motor output filter functions.

Filters of different manufacture can also be utilised. In this case **Parker Hannifin S.B.C. division offers its technical support by testing the filter you intend to use and generating a test data report.**

#### **CERTIFIED FILTER CONFIGURATIONS IN COMPLIANCE WITH EN55011 (group 1 classes A and B)**

High attenuation S.B.C. three-phase filters are specifically designed for S.B.C. brushless motor drives in compliance with the standard IEC950 for stray current up to 3.5 mA (380 - 50 Hz) for semi-static equipment.

#### **TECHNICAL FEATURES**

Enclosure	metal
Protection degree	IP20
Temperature	-25 ... +50 °C
Rated voltage	480 V~ @ 50°C, 50-60 Hz

S.B.C. FILTERS			
code	typo	current A @ 40°C	enclosure
SBC3RD7M	mains	8	
SBC3RD16M	mains	18	
SBC3RD30M	mains	34	
SBC3M10M	motor	10	F6
SBC3M20M	motor	20	F6



**Configuration 1 Class A**

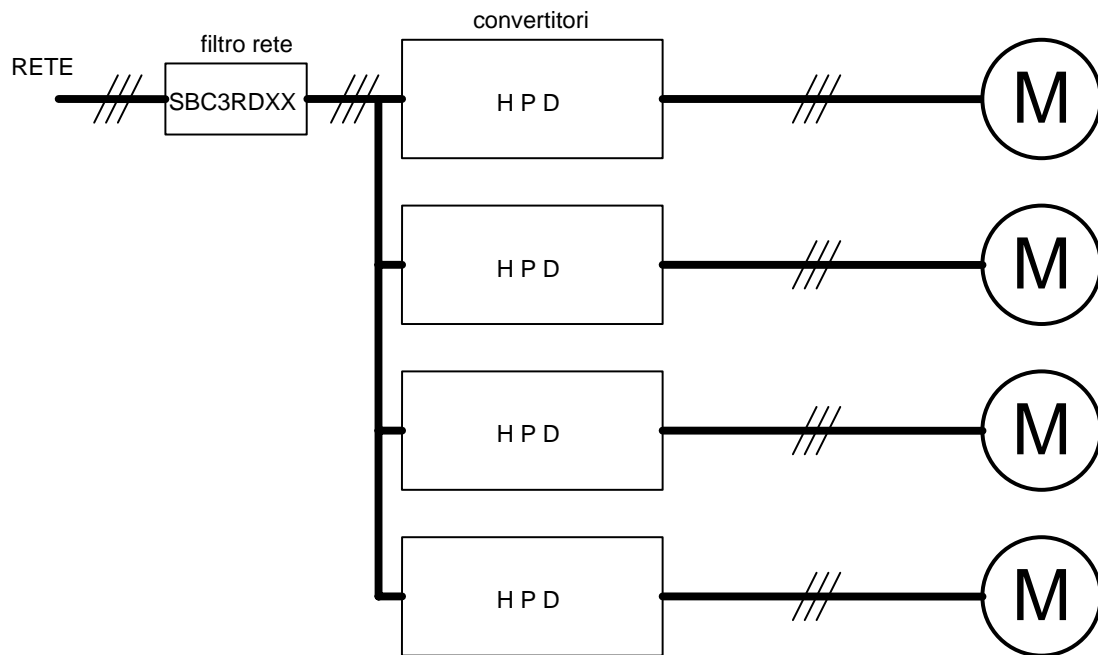

Where HPD rating is between 2 and 16 A

The sum of the rated current values must not exceed the XX mains filter rated current

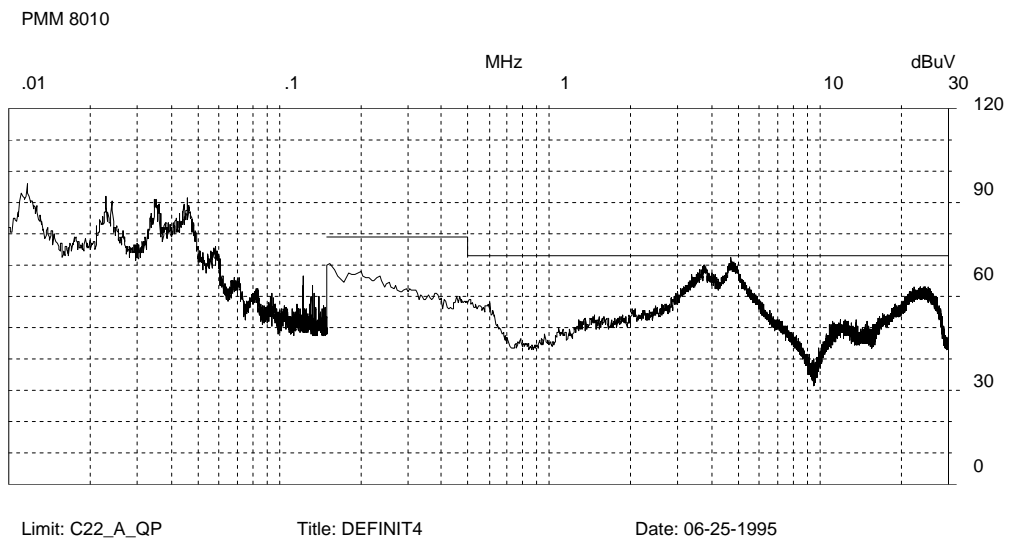

**Configuration 2 Class B**

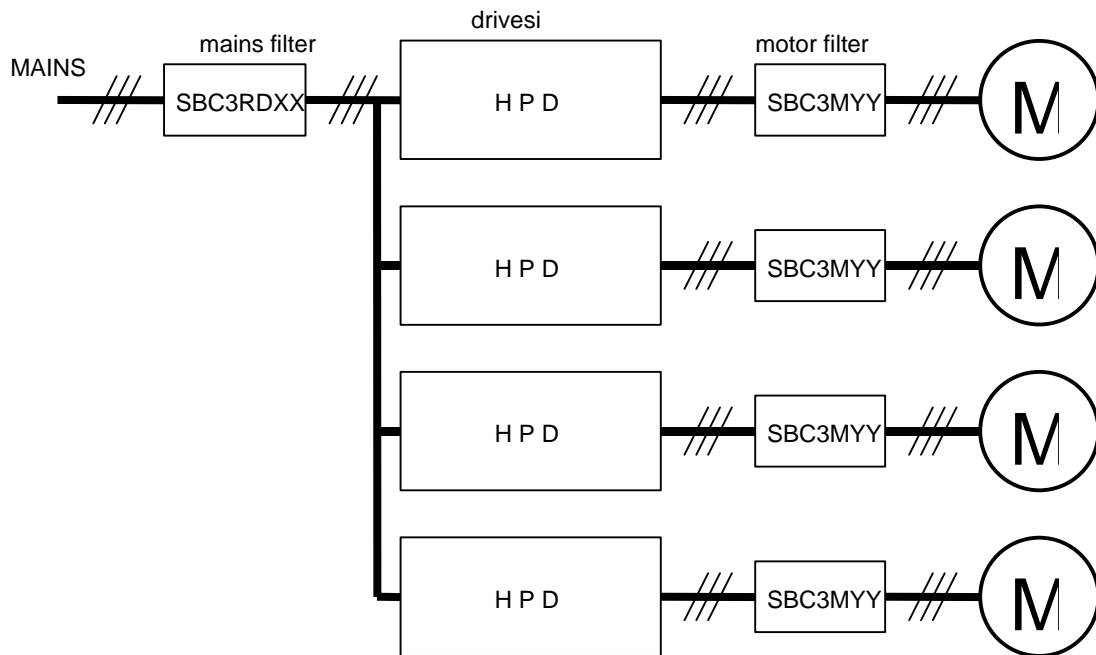

Where HPD rating is between 2 and 16 A

The sum of drive rated current values must not exceed the XX mains filter rated current

YY can be 10 or 20 and represents the motor filter rated current; drive rated current must not exceed that of the filter

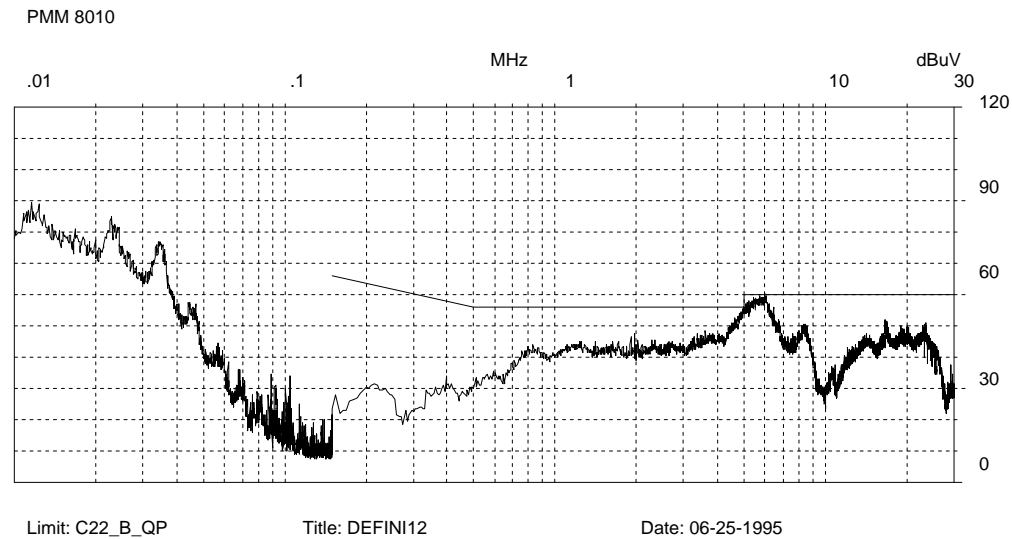

**3.6. Terminal assignments**

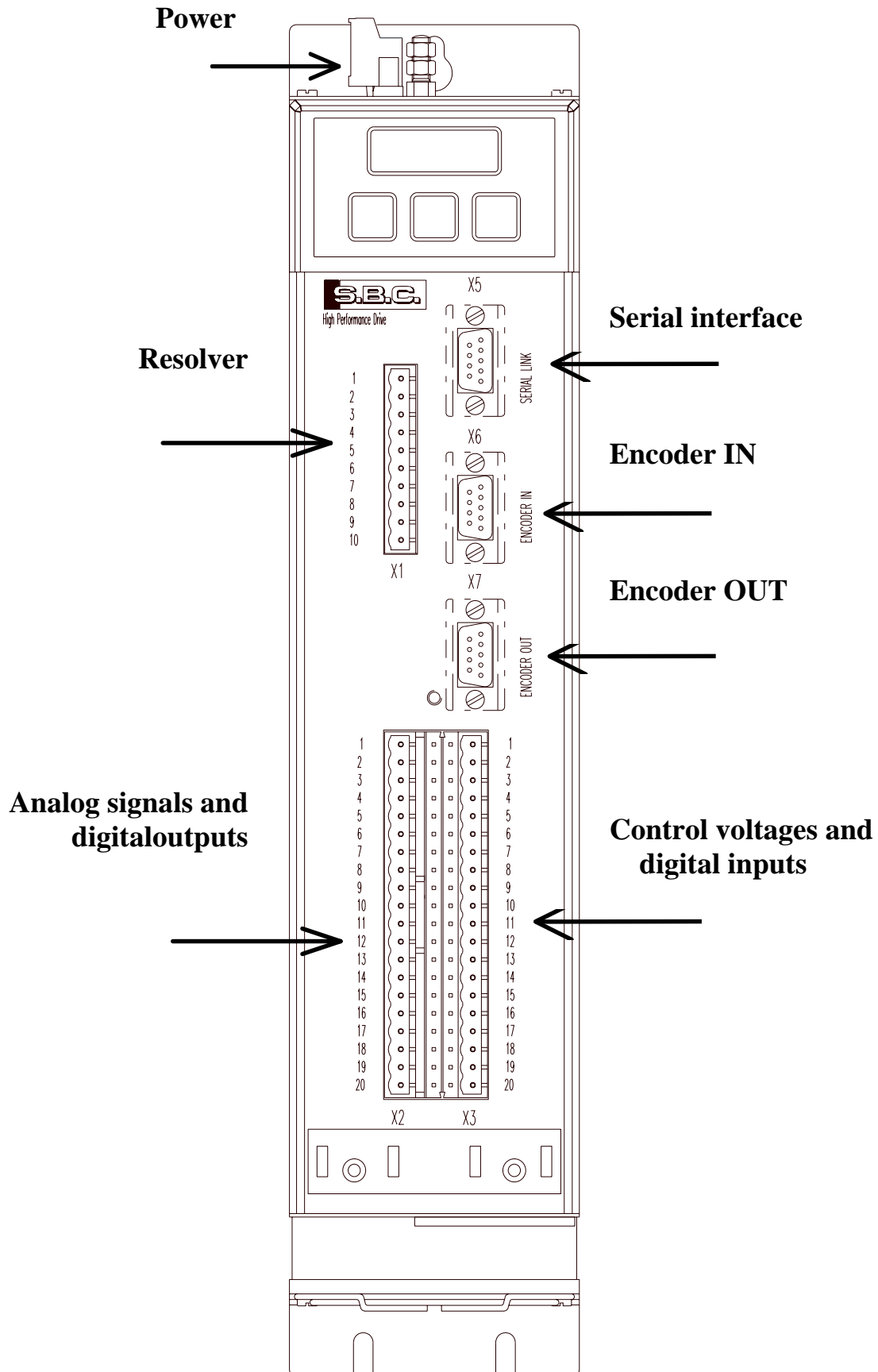

Terminal board X1	
1	motor PTC + ( 24 V )
2	motor PTC -
3	resolver, EXCT +
4	resolver, EXCT -
5	resolver, SIN +
6	resolver, SIN -
7	resolver, COS +
8	resolver, COS -
9	0 V
10	0 V

Terminal board X4	
1	L 1
2	L 2
3	L 3
4	U PHASE
5	V PHASE
6	W PHASE
7	AB
8	BB
9	EB
10	IB
11	+ DC BUS
12	- DC BUS

Terminal board X2	
1	reference high +
2	reference low -
3	0 V
4	Aux reference high +
5	Aux reference low -
6	0 V
7	Aux. analogue output
8	0 V
9	tacho output
10	0 V
11	digital out 0
12	digital out 1
13	digital out 2
14	digital out 3
15	digital out 4
16	digital out 5
17	digital out 6 A
18	digital out 6 B
19	+ 24 Vdc - OUT 200 mA
20	0 V

Terminal board X3	
1	+ 10 V - 10 mA max
2	0 V
3	- 10 V - 10 mA max
4	0 V
5	+ 24 V - IN
6	0 V
7	0 V
8	+ V backup
9	- V backup
10	0 V
11	drive enable
12	digital input 1
13	digital input 2
14	digital input 3
15	digital input 4
16	digital input 5
17	digital input 6
18	digital input 7
19	+ 24 V - OUT 200 mA
20	0 V

DB9 female type X5	
1	TX
2	RX
3	/TX
4	/RX
5	
6	+BR
7	-BR
8	0 V
9	0 V

D DB9 female type X6	
1	A
2	/A
3	B
4	/B
5	-BRA
6	+BRB
7	0 V
8	-BRB
9	+BRA

DB9 male type X7	
1	PHA
2	/PHA
3	PHB
4	/PHB
5	PHC
6	/PHC
7	0 V
8	
9	

### 3.7. Power connections

#### For the motor cable consider

Choice between cable for fixed or floating installation.

Cable must be shielded and suitably sized in terms of insulation and wire sections.

Reticulated polypropylene is the preferred insulation material.

Length (max 100 m); note that conductor-conductor capacitance must not exceed 8 nF.

If cable length exceeds 35 m install a triple inductance between drive and motor with rated current identical to HPD rated current.

Minimum conductor size is 1.5mm<sup>2</sup> for HPD2N and HPD5N , 2.5mm<sup>2</sup> for HPD8N and 4mm<sup>2</sup> for HPD16N, HPD20N and HPD24N.

#### For the mains power cable

Power cables must not be shielded.

Minimum conductor size is 1.5mm<sup>2</sup> for HPD2 and HPD5, 2.5mm<sup>2</sup> for HPD8 and 4mm<sup>2</sup> for HPD16 HPD20N and HPD24N.

Input fuses must be rated as follows:

<i>MODEL</i>	<i>Slow blow fuses (A)</i>
HPD2N	6
HPD5N	10
HPD8N	16
HPD16N	20
HPD20N	25
HPD24N	25

#### Resolver cable

The cable must comprise 4 twisted pairs with individual shields and one common shield.

Capacitance for the length of cable must not exceed 10 nF; wire size must be no less than 0.35mm<sup>2</sup>.

Maximum length is 100 m.

See the section "resolver connections".

#### EMI filter connection

The connection between filter and drive must never exceed 30 cm. If the distance is less than 15 cm unshielded cables are possible, otherwise a shielded cable must be used.

### Earth connections

To reduce the length of individual conductors that must be connected to earth we recommend using an earth busbar located as near as possible to the drive.

The busbar must be made of copper to ensure low inductance. It must also be mounted on insulated fixings. The adjacent table shows minimum dimensions according to length.

<i>Length (m)</i>	<i>width (mm)</i>	<i>thickness (mm)</i>
0.5	20	6
1	40	6
1.5	50	6

### 3.8. Power connection layout

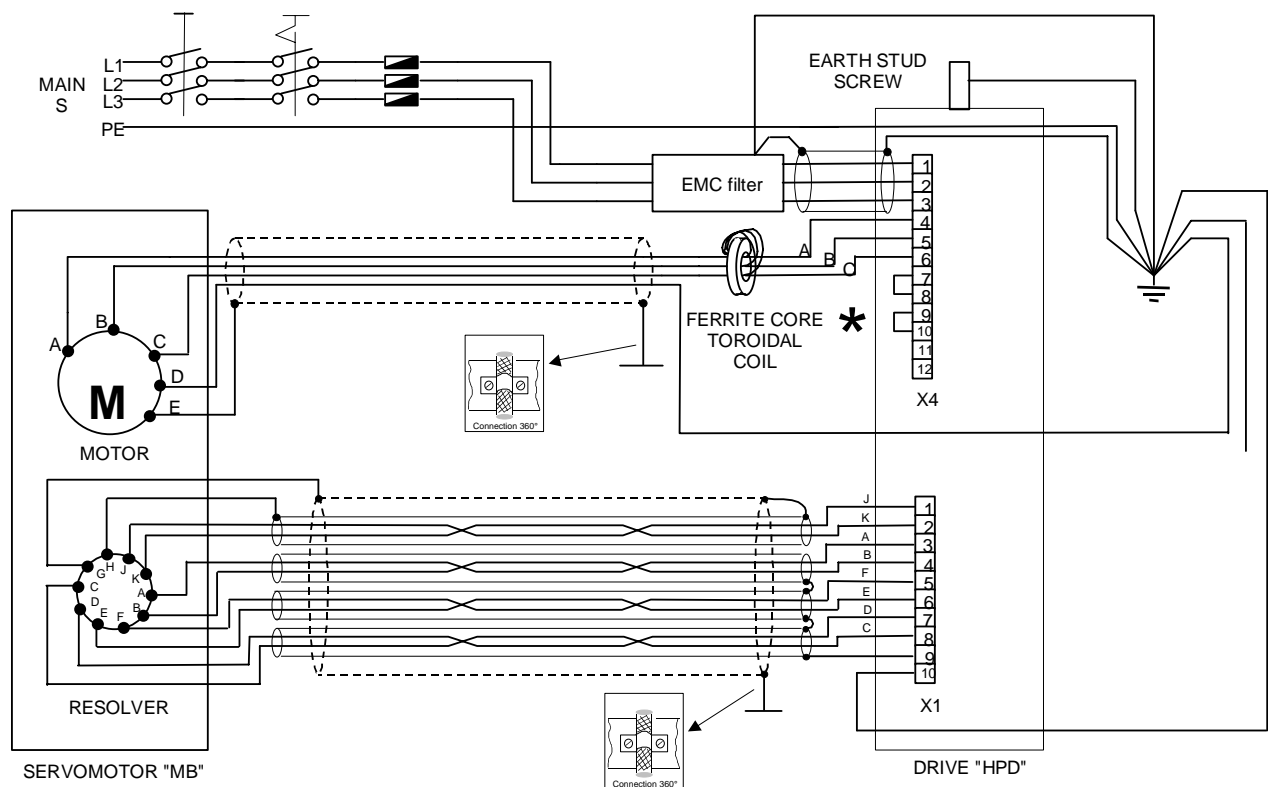

\*

FERRITE COIL, MOTOR FILTER OR NOT PROTECTION ACCORDING TO CHOSEN CONFIGURATION

ATTENTION: respect suitable connections meticulously (with particular attention to the shield) for a correct operation system.

N.B. the protection of the resolver cable in general must be all connected to the clamp 9 of X1. Side motor, the protection of the connected duplex cable to [j-k] must be connected to H, the general protection to G. the other protections must not be connected.

### 3.9. Signal cable connections

A twisted and shielded pair must be employed for the analogue reference.  
 The cable for emulated encoder signals must comprise three twisted pairs with a common shield.  
 Normal cables can be used for digital inputs/outputs.

**Minimum size of all signal wires is 0.35mm<sup>2</sup>**

### 3.10. Signal cable connection layout

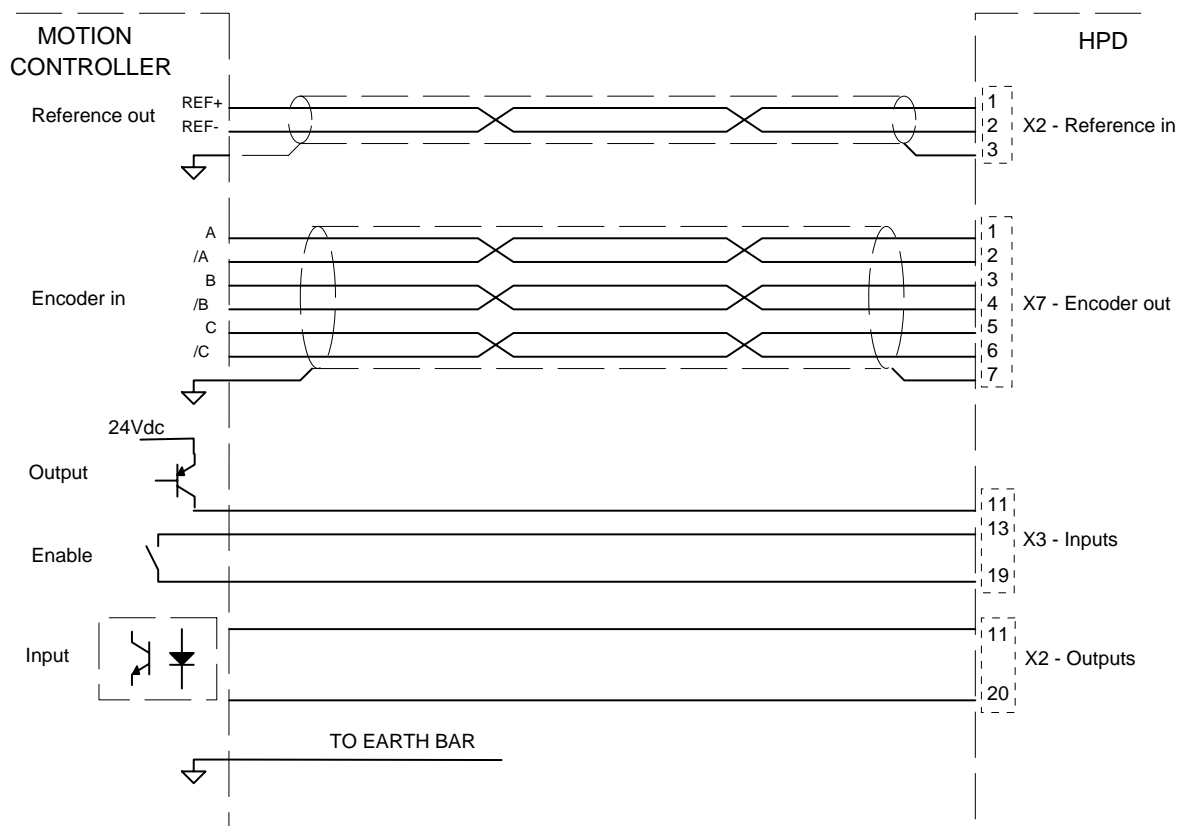

### 3.11. Frequency input connection

The frequency input, RS-422 type in X6, can be software-configured in two different ways: the first (default) to accept two quadrature signals (for example, from encoders), the second is frequency/direction type (see chapter *Basic parameters* bit b42.5).

In the first case the scheme to use is the follow:

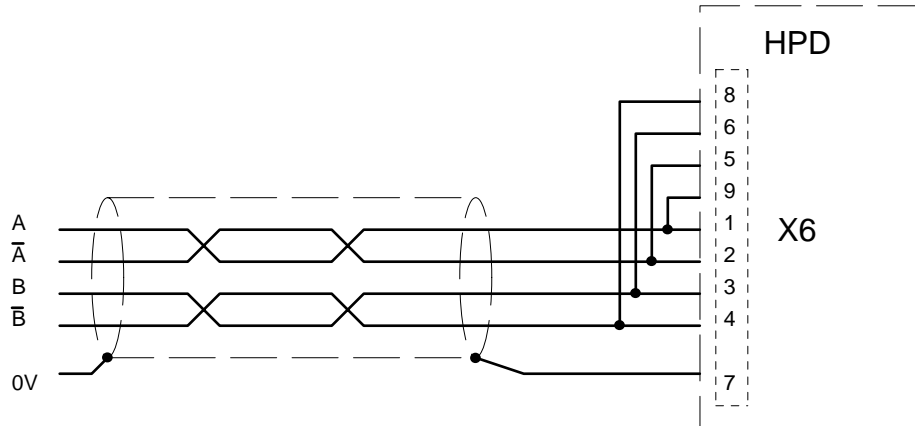

In case of parallel connections to more than one HPD, connections to pins 9, 5, 6, and 8, must be made only on the last drive in the group.

In the second case, there are two possible solution for to control the drive with input signal from X6 frequency/direction type:

- by "PLC-Line driver interface" board (available to our products);
- by showed below.

When CLOCK and DIR signals are to 24Vdc, execute the connections: channel A is dedicated to frequency while channel B to direction.

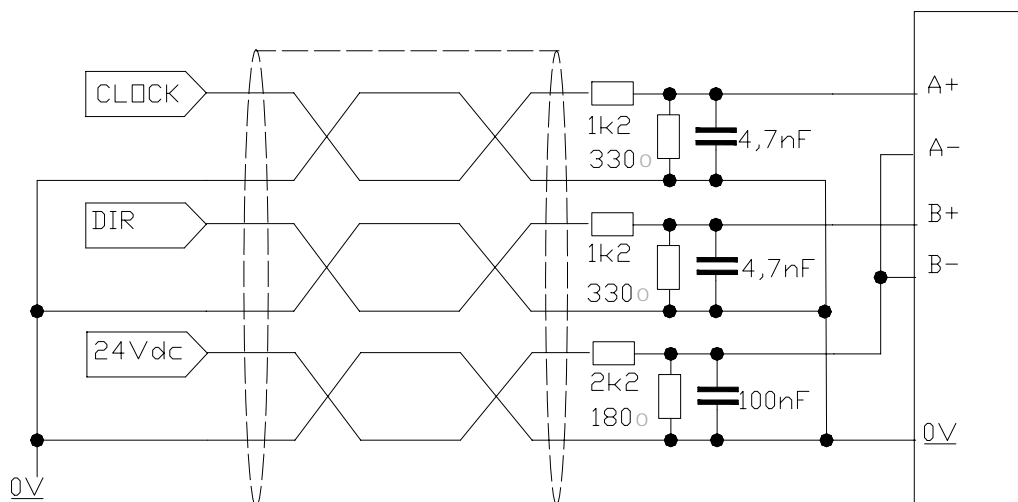

- Cable shielded with 3twisted pairs.
- Connect the resistances near to the terminal of the drive (max. 5cm).
- For the fixing of the cable-shields use the connections shown on the picture beneath.

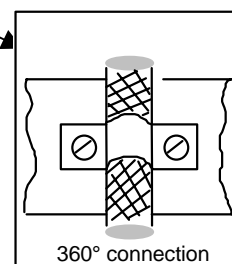



When CLOCK and DIR signals are to 5Vdc, execute the connections:

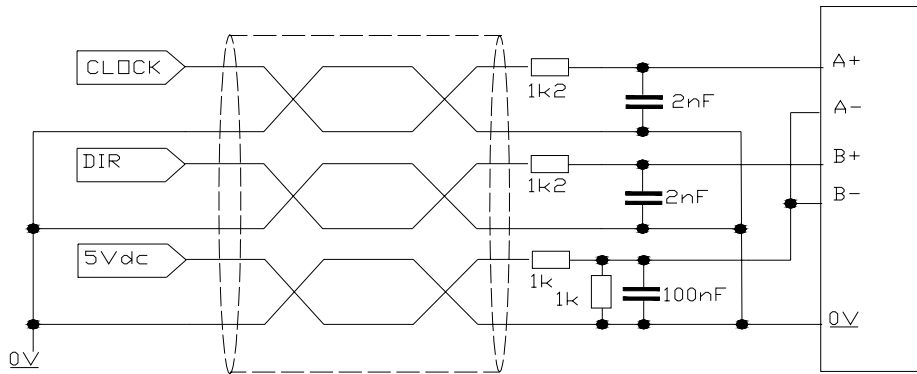

- Cable shielded with 3 twisted pairs.
- Connect the resistances near to the terminal of the drive (max. 5cm).
- For the fixing of the cable-shields use the connections shown on the picture beneath.

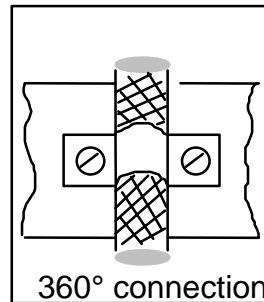

**HPD connection with digital locking**

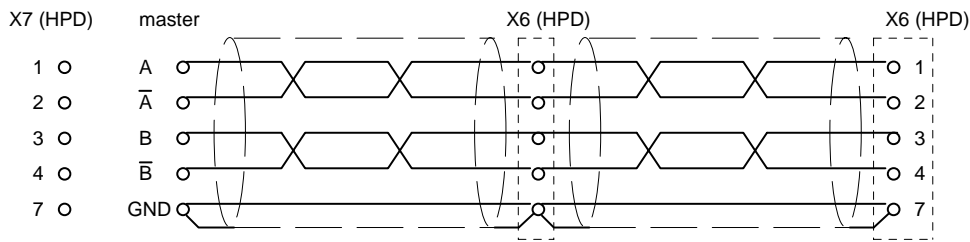

see text for burden resistors

The example in the figure shows the connection between two HPD drives in digital lock with a master, but this configuration can be extended to several drives connected in series. On the final drive in the series connect the burden resistors by jumpering pin 1 with pin 9, pin 2 with pin 5, pin 3 with pin 6 and pin 4 with pin 8 on connector X6. The master can be an externally fed encoder, or the simulated encoder output on another drive.

The signal from the master encoder must be differential type 5V RS-422; it is therefore possible to connect a maximum of 10 slave HPDs.

If the master is an HPD drive, then up to 32 units can be connected in digital lock mode using the same simulated encoder signal (RS-422 standard).

For the relative programming of the HPD, consult the *Digital locking* chapter in this manual.

### **3.11.1. Encoder emulation**

On connector X7 there are signals of encoder emulation phase A, phase B and phase C (reference zero). The signals are RS-422 type. For the relative programming of pulses per revolution consult the *Basic parameters* chapter in this manual, bit b42.0, b42.1 and b42.2 (default = 1024 pulses/revolution).

### **3.12. Serial line connection**

The HPD drive serial line can be configured as RS-422 or RS-485 depending on the connection. In both cases termination resistors must be used (150  $\Omega$ ). Where more than one HPD drive is connected to the bus the final node must be terminated as shown below. The two cases are illustrated in the following diagrams.

### 3.13. Braking resistor

HPD drives are equipped with an integrated braking resistor. If you intend to dissipate more power, use an external braking resistor. To connect up the system (which must be carried out in conditions of complete safety) disconnect the jumper between terminals 9 and 10 of terminal board X4; connect one end of the resistor to terminal 9 and the other to terminal 11 on X4. The external resistor value must be 40 ohm for HPD2N, HPD5N, HPD8N and HPD16N, 27 ohm for HPD20N and HPD24N, and a thermal magnetic circuit breaker must be installed between resistor and drive. The minimum wire size for the connection is 4 mm<sup>2</sup>; the connection cables should be as short as possible and, in any event, no longer than 3 metres.

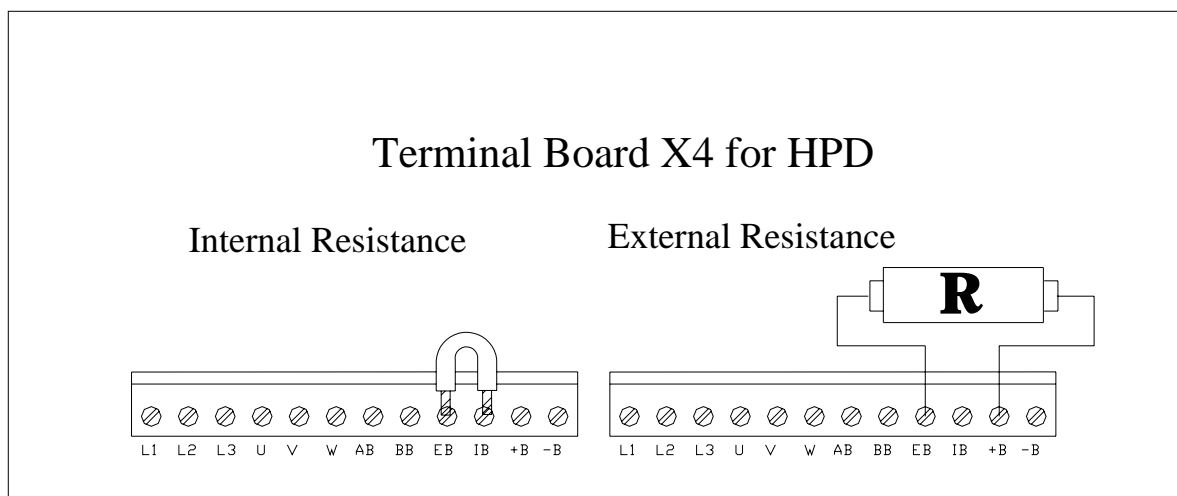

### 3.14. Backup

Precaution for simulation encoder:

- Use an external 24Vdc 2A regulated power supply with protected output.
- Set the parameter b99.8 = 1 (the automatic reset of the undervoltage alarm when the mains voltage is restored). Now the backup function does not need the external relay.  
Furthermore is not required to write in the pico-PLC the programme described in the example 11 - "Examples and applications" chapter.

## 4. PARAMETERS AND PROGRAMMING

The features: torque, speed, acceleration and position control are the task of a dedicated electronic circuits. In this chapter you can see how to set up and the meaning of any parameter, functional block diagrams and advanced functions description too. In the figure below it is described the general block diagram of the drive's functions that you can configure by parameters.

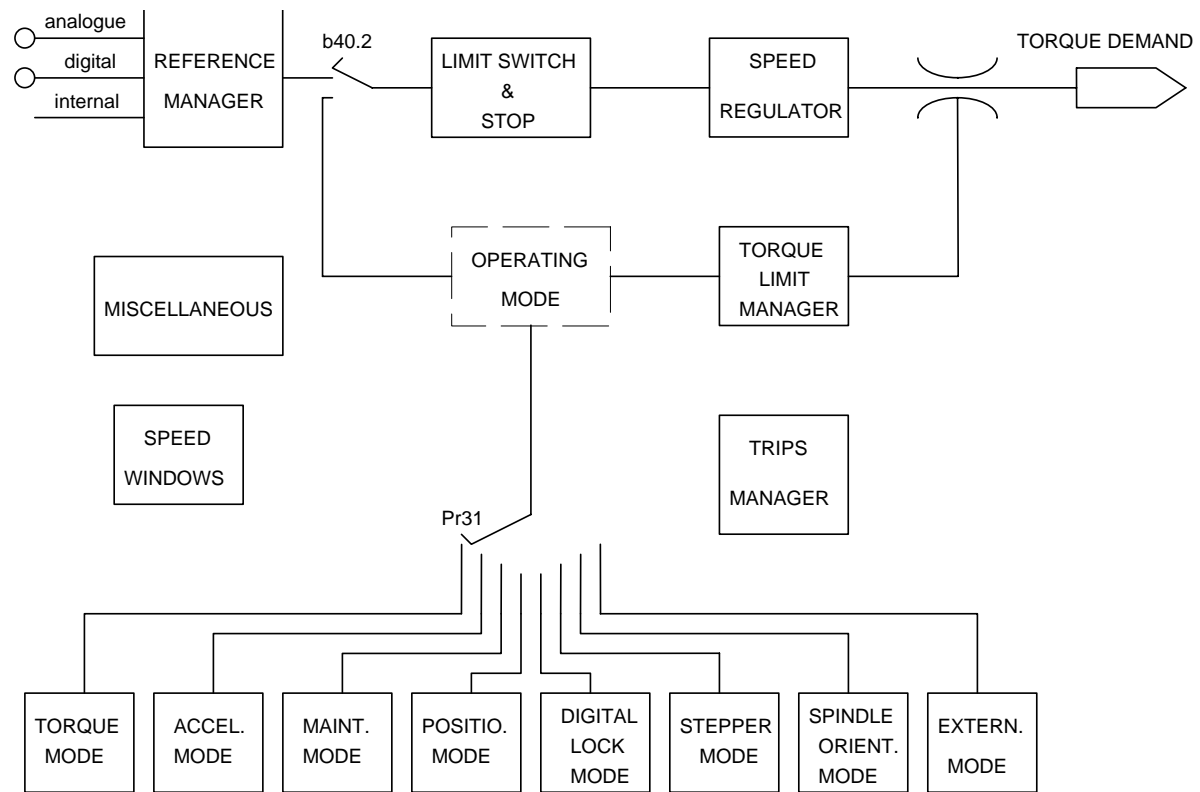

See chapter *Block diagrams* for a better description of how to use the drive, especially for operating modes. See chapter *Pico-PLC* to understand how to connect peripheral systems (inputs/outputs) to the parametric system of the HPD drive.

Parameters are divided as follows:

from Pr0 to Pb42	basic parameters
from Pr50 to Pb70	operating mode parameters
from Pr71 to Pb99	pico-PLC parameters
from In0 to In63	pico-PLC instructions

The principal parameter units and resolutions are:

parameter	unit	resolution
speed	revolutions per minute	1
acceleration	seconds / 1000 rpm.	0.001
position	4096 steps / revolution	1/4096 revolution
current	% of the drive peak current	0.1

### 4.1. Using the keypad

The keypad-display module is designed to provide an intuitive operator interface. It can be used to program operating data, monitor system status and enter commands.

The module has only three keys, located at the top of the front panel just below the display. The keys are marked: [M], [+] and [-].

[M] is used to change the display mode and consequently also the function of [+] and [-].

There are two display modes: parameter mode and parameter value mode.

When the unit is powered up, provided there are no active alarms, the message "Idle" (drive disabled) or "run" (drive enabled) is displayed; this is also the position of parameter Pr0.

Press [+] or [-] to scroll through the parameters.

If you want to check a parameter value, press [M]; when the value is shown it can be updated using [+] and [-].

To return to parameter mode press [M] again.

The display can be shown in various forms, depending on the parameter in question.

If you need to increase (or decrease) a parameter value quickly, press [M] while the up key [+] (or down key [-]) is pressed.

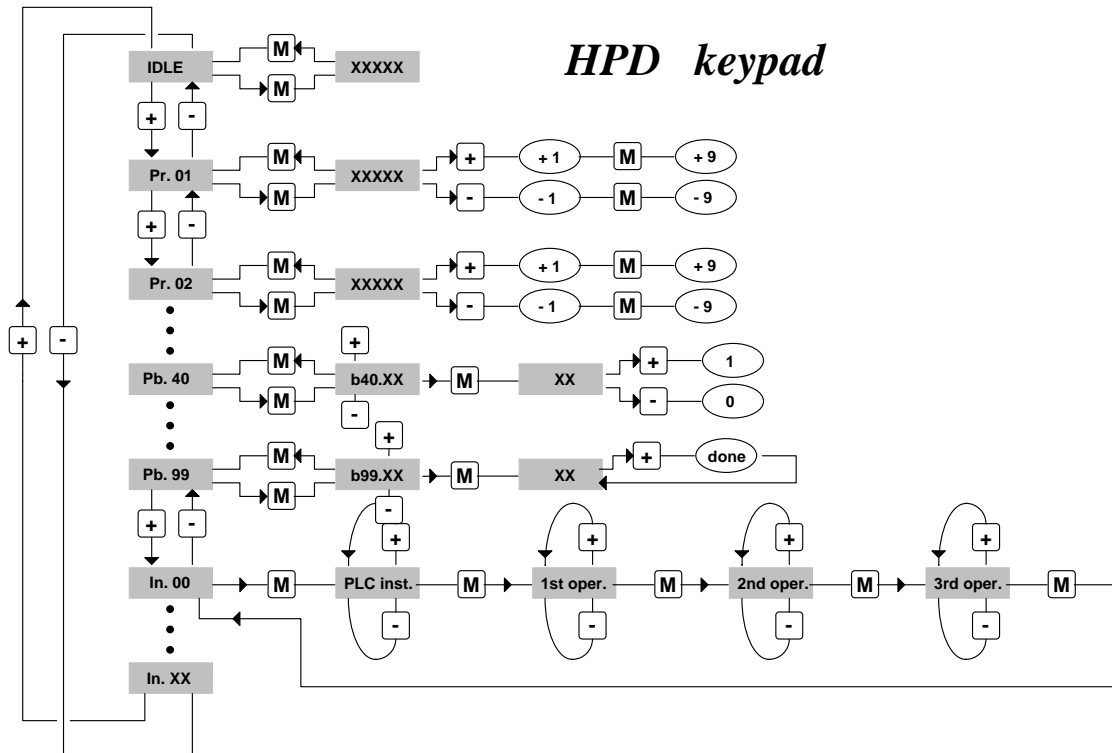

In addition to the parameter values and the pico-PLC instructions, the display may show the following messages:

- r. xx** At the time of power-up this message indicates the software version installed (2 seconds approx.).
- IdLE** At power-up and in correspondence with Pr0 this message shows that no alarms are present and the system is disabled.
- run** At the time of power-up and in correspondence with Pr0 this message indicates that no alarms are present and the drive is enabled; the motor shaft may be spinning.
- Er. xx** In correspondence with Pr0 this message indicates that the drive has detected an alarm (xx indicates the alarm code) and has therefore been disabled. When an alarm is detected the display automatically switches to parameter Pr0 and shows the alarm code.
- dcbuS** In correspondence with Pr0 this message indicates that the drive is not operating at low voltage (b40.10=0) and that DC bus voltage is still below the 120 V threshold; the inrush current circuit is still connected so the drive is not yet ready (b41.4=0).
- Prxx** Indication of parameter xx (value displayed by pressing "M").
- Pb. xx** Indication of bit parameter xx.
- bxx.yy** Indication of bit yy of parameter xx; press "M" to display bit status.
- In. xx** Indication of instruction xx of PLC program.
- donE** Displayed for approximately 1 second each time a command is entered.
- rESet** Displayed for approximately 1 second each time an alarm reset command is entered (b99.10).
- tESt** Displayed during wiring test (b70.3).
- rEtrY** It's displayed when a writing error is detected storing the pico-PLC instructions (b99.14) or while saving parameters (b99.15).

## 4.2. Commissioning the HPD drive

The steps described in this section must be followed carefully when the drive is started up for the first time.

- 1) Connect the motor to the drive in compliance with the wiring diagrams in the manual.
- 2) Make sure the drive is disabled (terminal 11 of board X3 must be open)
- 3) Power up the drive.
- 4) After some seconds the display shows "IdLE".
- 5) Setting essential parameters:  
Pr33 calculation (rated current)

$$\text{Pr33} = \frac{\text{InM}}{\text{InD} \cdot 2} \cdot 100$$

where: InM is rated motor current at zero rpm in Ampere  
 InD is rated drive current in Ampere  
 The maximum value of Pr33 is 50.0 except for HPD20N because the limit is 31.

Pr19 calculation (peak current)

$$\text{Pr19}_{\text{MAX}} = \text{Pr33} \cdot 3$$

The maximum value must be no higher than three times the value of Pr33

Pr29 calculation (number of poles)

Use the following table for MB series motors

<i>Flange ( mm )</i>	<i>Pr29</i>
56	4
70	4
105	8
145	8
205	8

Pr32 calculation (rated speed)

If Pb 42.6=0       $\text{Pr32} = V_{\text{max}} \cdot 1.12$

If Pb 42.6=1       $\text{Pr32} = \frac{\omega \cdot V_{\text{MAIN}}}{V_{\text{MOT}}} \cdot 8.3$

where:  $\omega$  is nominal motor speed in rad/sec  
 Vmain is HPD power supply in Vrms  
 Vmot is motor rated voltage in Vrms

Evaluation of Pr16 and Pr17 (speed regulator gain)

The default values of Pr16 and Pr17 have been chosen considering identical motor and drive rated currents; if this is not the case correct the values of parameters Pr16 and Pr17 with the ratio of the motor rated current/drive rated current. Preventive execution of this compensation will eliminate the risk of motor vibration at the first start-up.

- 6) Set the analogue reference signal to 0 V (terminals 1, 2 of board X2), and enable the drive (24 V on terminal 11 of board X3 ).
- 7) The motor shaft must be stopped; when the analogue reference voltage is changed motor speed should change proportionally. If this is not the case check your wiring.
- 8) Save your changes with b99.15.

The drive is preset with default values designed to meet the requirements of the majority of applications. With the default values the pico-PLC in the drive runs the program described in appendix G, so the following functions will be present on the input and output terminal boards:

TERMINAL BOARD X2	
11	real speed > Pr13
12	motor speed = reference (+/- 20 rpm)
13	real speed = 0
14	real speed > 0
15	motor thermal image active (i <sup>2</sup> t)
16	
17	terminal A                  drive ready
18	terminal B                  (n.c. contact)

TERMINAL BOARD X3	
11	start drive
12	left-hand stroke end (n. c.)
13	right-hand stroke end (n. c.)
14	emergency stop (n. c.)
15	clockwise/counter-clockwise rotation
16	start / stop
17	
18	

The functions on terminals 12, 13 and 14 must be enabled by setting bit b90.10 to one. This requires access to the extended parameters menu.

The default PLC program controls parameter Pr5 in addition to timer 1 (Pr92) and bits b40.0, b40.4, b40.5, b40.6, b40.12 so in this case the above binary parameters and switches cannot be utilised unless the pico-PLC is disabled (b99.13=0) or the basic program is modified.

### Short and extended menu

When the HPD drive is in default status, only a limited number of parameters are displayed. These parameters are the only ones required for applications in which the HPD is employed as a straightforward frequency converter, i.e. you are not using the advanced functions of the drive (e.g. using HPD with a Numerical Control or an intelligent axis control card). Switch between short and extended menu using b99.6.

Short memory parameters are:

- Pr0      Real speed of motor shaft in rpm.
- Pr1      Analogue reference offset (terminals 1 and 2 of terminal board X2 ).
- Pr2      Analogue reference full scale: speed value in rpm corresponding to 10 V reference signal.
- Pr8      Acceleration/deceleration ramp values in seconds per 1000 rpm
- Pr16     Integral gain of speed control loop.
- Pr17     Speed control loop damping.
- Pr19     Peak current delivered to drive expressed as a percentage of the peak rated value of the drive.
- Pr29     Number of motor poles.
- Pr32     Rated speed (rpm).



- Pr33 Rated current that can be delivered by the drive (can be maintained indefinitely) expressed in percent of the peak rated current of the drive.
- Pr35 Instantaneous current requested by the motor expressed as a percentage of drive peak rated current.
- b99 Bit parameter for the fundamental orders.

Using extended menu you can manage all parameters and pico-PLC instructions.

### Restoring default parameters

- If you need to restore the factory-set default parameter values:
- disable the drive via hardware (open terminal 11 on board X3)
  - power-up the system
  - the display will show "IdLE" after approximately 3 seconds
  - set b99.7 and b99.13 to zero
  - enter command b99.12
  - save your changes with b99.14 and b99.15.

## 4.3. Basic parameters

To access all the following parameters open the extended menu by setting b99.6 to one. For this procedure, b99.7 must be set to zero.

### DECIMAL PARAMETERS

- Pr0 Motor speed:** this is a read-only parameter expressed in rpm; the message Pr0 never appears on the display. In its place a message corresponding to drive status is shown.
- Pr1 Analogue reference offset.** This is expressed in input A/D converter counts. Programming limits are -10000 and +10000 while the range of the A/D converter is from -16384 to +16383 over  $\pm 10$  V.
- Pr2 First full scale of analogue reference.** Unit=rpm, range= $\pm 10000$ , default=3000. If b40.0=0 and b40.12=0, Pr7 will be equal to:  $V_{in} \cdot Pr2 / 9.76$  where  $V_{in}$  is the voltage on the analogue input.
- Pr3 Second full scale of analogue reference.** Unit=rpm, range= $\pm 10000$ , default=-3000. If b40.0=1 and b40.12=0, Pr7 will be equal to:  $V_{in} \cdot Pr3 / 9.76$  where  $V_{in}$  is the voltage on the analogue input.
- Pr4 Frequency reference full scale** (connector X6). Unit=rpm, range= $\pm 32767$ , default=3000. If b40.12=1 and b40.13=1, Pr7 will have the following value:
- if b42.5=0  $Pr7 = Fin \cdot Pr4 / 2000000$  (frequency/direction signal)
- if b42.5=1  $Pr7 = Fin \cdot Pr4 / 500000$  (quadrature signal)
- where  $Fin$  is the frequency on the encoder input.

- Pr5 Internal reference.** Unit=rpm, range= $\pm 9000$ , default=0. If b40.12=1 and b40.13=0, Pr7 will be the same as Pr5.
- Pr6 Reserved read-only speed reference.** Unit=rpm, range= $\pm 9000$ . If b40.2=1 Pr6 is only utilised as a speed reference for the control loop. The active operating mode will enter its speed request in parameter Pr6.
- Pr7 Main reference (read-only parameter).** Unit=rpm, range= $\pm 9000$ . If b40.2=0, Pr7 is used as a reference for the speed control loop. In certain operating modes Pr7 can be used as a reference for other factors (torque / acceleration). In this case Pr7 is expressed in a suitable unit.
- Pr8 Acceleration ramp for positive speed values.** Unit=s/krpm range=0.002..65.535, resolution=0.001 s, default=0.002 s. Acceleration for positive speeds required of the motor by way of the speed reference is internally limited so that acceleration of 1000 rpm takes Pr8 seconds.
- Pr9 Deceleration ramp for positive speed values.** Unit=s/krpm, range=0.002..65.535, resolution=0.001 s, default=0.002 s. Deceleration for positive speeds required of the motor by way of the speed reference is internally limited so that deceleration of 1000 rpm takes Pr9 seconds.
- Pr10 Acceleration ramp for negative speed values.** Unit=s/krpm, range=0.002..65.535, resolution=0.001 s, default=0.002 s. Acceleration for negative speeds required of the motor by way of the speed reference is internally limited so that acceleration of 1000 rpm takes Pr10 seconds.
- Pr11 Deceleration ramp for negative speed values.** Unit=s/krpm, range=0.002..65.535, resolution=0.001 s, default=0.002 s. Deceleration for negative speeds required of the motor by way of the speed reference is internally limited so that deceleration of 1000 rpm takes Pr11 seconds.
- Pr12 Deceleration ramp for stroke end and stop functions.** Unit=s/krpm, range=0.002..65.535, resolution=0.001 s, default=0.002 s. Deceleration required of the motor by the stroke limit and stop functions is internally limited so deceleration of 1000 rpm takes Pr12 seconds.
- Pr13 Overspeed threshold.** Unit=rpm, range=0..+13000, default=3500. If the absolute value for motor speed exceeds the value entered in Pr13, b41.0 must be =1, otherwise it will be = 0.
- Pr14 High speed threshold.** Unit=rpm, range= $\pm 13000$ , default=20. When b40.7=0, if the speed difference between motor and reference is less than Pr14 and greater than Pr15, b41.1 will be =1, otherwise it will be = 0. In the case of b40.7=1, if motor speed is less than Pr14 and higher than Pr15, b41.1 will be =1, otherwise it will be =0.
- Pr15 Low speed threshold.** Unit=rpm, range=  $\pm 13000$ , default=20. When b40.7=0, if the speed difference between motor and reference is less than Pr14 and greater than Pr15, b41.1 will be =1, otherwise it will be =0. In the case of b40.7=1, if motor speed is less than Pr14 and higher than Pr15, b41.1 will be =1, otherwise it will be =0.
- Pr16 Integral gain of speed control loop.** Range =0...32767, default=120.
- Pr17 Speed control loop damping.** Range=0...32767, default=2000. If Pr16 is set to zero Pr17 sets the value for proportional gain of the speed control loop.
- Pr18 Bandwidth limiter.** Unit=512 $\mu$ s, range=0..1000, default=1. Use Pr18 to set the time constant of a first order filter located on the digital torque demand signal. The filter cut-off frequency will be: 310/Pr18 Hertz.

- Pr19 Peak current.** Unit=%, range=0..100.0%, resolution=0.1%, default=100.0%. Maximum current that the drive can deliver to the motor expressed as a percentage of drive peak current. It is good practice to maintain this value to within 3 times the rated motor current.
- Pr20 DC bus voltage.** Unit=volt, read-only parameter. Shows the value of DC bus voltage.
- Pr21 Torque limiter,** read-only parameter. Unit=%. Can be used by operating modes to restrict motor torque.
- Pr22 Auxiliary analogue reference.** Unit=%. The displayed value will be  $Pr22 = V_{in} \cdot 100 / 9.76$ . Resolution is 0.2%.
- Pr23 Alarm code.** This code shows the currently active alarm; zero means that no alarms are active. Consult the table of alarm codes for more details.
- Pr24 Last alarm.** This parameter stores the last alarm. Pr24 is reset when the alarm reset command is entered (b99.10).

Alarm code	Alarm
0	no alarm
1	overvoltage
2	undervoltage
3	overcurrent
4	resolver alarm
5	motor overheating
6	drive overheating
7	external alarm
8	auxiliary alarm
9	digital output overcurrent alarm
10	PLC check-sum
11	parameter check-sum

- Pr25 Code describing installed software version.** Read-only parameter.
- Pr26 Serial line baud-rate code.** Default=8. This is the code for programming transmission speed. For more information consult the section on the serial interface.
- Pr27 Serial line address code.** Default=0, possible settings=0..31. For more information consult the relative section of the manual.
- Pr28 Motor shaft position.** Unit=steps, range=0..4095. Read-only parameter that shows the absolute position of the resolver.
- Pr29 Number of motor poles.** Possible settings=2..64, default=8.
- Pr30 Resolver position offset.** Default=0; use Pr30 for electronic correction of the mechanical resolver position.
- Pr31 Operating mode.** Default=0. Use Pr31 to select the active operating mode. 0 indicates no operating mode.
- Pr32 Rated speed.** Unit=rpm, range=0..9000, default=3200. Nominal motor speed. Should be programmed with the motor speed at which rated voltage corresponds to drive power feeding voltage reduced by 13%. Consult the formula in section *Commissioning the HPD drive*.

- Pr33 Motor rated current.** Unit=% of peak current, range=10.0..50.0%, resolution=0.1% default=50.0%. Enter motor rated current.
- Pr34 Tacho generator emulation output gain.** Default=127. Use parameter 34 to alter analogue output gain in proportion to speed (terminal 9 on board X2). The analog output value (Volt) is:

$$tacho = \frac{Pr0 \cdot Pr34}{K \cdot 15875}$$

where: K = 1 if Pr32 ≤ 875  
 K = 4 if 875 < Pr32 ≤ 3500  
 K = 16 if Pr32 > 3500

- Pr35 Torque monitor.** Unit=% of peak torque, resolution 0.1%. This parameter indicates the percentage of torque (or current) that the motor is delivering.
- Pr36 Thermal image of motor winding.** Unit=% of reference temperature. This read-only parameter indicates an estimation of the heat on the innermost windings of the motor. If the value reaches 100.0 %, which is equal to the nominal value, b41.11 switches to 1 so that current can be limited to the rated value.
- Pr37 Thermal image of braking resistor.** Unit=% of nominal temperature. This read-only parameter indicates an estimation of the heat on the braking resistor. If the value reaches 100.0 % or more, consider using an external braking resistor.
- Pr38 Auxiliary analogue output.** Unit=% of 9.76V, default=0, range=±100.0%, resolution 8 bit. If b40.11 is equal to 1, the auxiliary analogue output will be equal to 976·Pr38/100 volts.
- Pr39 Phase correction.** This parameter may be used in certain applications with special motors that are to run also at constant power. Range ±32000, default = 0.

## **BINARY PARAMETERS**

Binary parameter Pb40 can be read, written and saved. Binary parameter Pb41 provides information regarding system status. Parameters Pb42 and Pb99 are read/write parameters with save facility.

- b40.0** **Selecting the first or second speed reference full scale value.** Default=0. If set to 0 Pr2 is used to standardise the analogue reference. If set to 1 parameter Pr3 is used.
- b40.1** **Activation of algorithm for the suppression of vibration at 0 rpm.** Default=0. Set to 1 to activate the algorithm.
- b40.2** **Selecting user/reserved reference.** If set to 1 the reserved reference is used in accordance with the currently active operating mode. If set to zero the reference selected by b40.0, b40.12 and b40.13. is employed. Default is 0.
- b40.3** **Reference freeze.** Default=0. If set to 1 the reference will not be updated so that motor will not follow input reference modifications. If set to zero the reference will follow variation in the input reference.
- b40.4** **Left-hand stroke end.** Default=0. If set to 1 and the selected reference requires negative speed, the reference will be forced to zero in accordance with the ramp in Pr12. If set to zero no type of control is performed.
- b40.5** **Right-hand stroke end.** Default=0. If set to 1 and the selected reference requires positive speed, the reference will be forced to zero in accordance with the ramp set in Pr12. If set to zero no control is performed.
- b40.6** **Stop function.** Default=0. If set to 1 the motor is stopped according to the ramp set in Pr12.
- b40.7** **Absolute/relative speed window selection.** Default=0. If set to zero speed windows Pr14 Pr15 b41.1 will operate in relative mode, if set to 1 the speed windows will operate in absolute mode.
- b40.8** **Analogue torque limit.** Default=0. If set to 1, Pr22, i.e. auxiliary analogue input, will be used to limit motor torque.
- b40.9** **Software enable.** Default=1. If set to zero the drive cannot be started.
- b40.10** **Low voltage operation enable.** Default=0. If at 1 the inrush current circuit will be connected each time the drive is disabled, thus permitting rapid increases in power supply voltage. When the drive is started the inrush current circuit will be connected before the effective start-up of the power stage. This procedure causes a drive start-up delay of 120ms.
- b40.11** **Analogue output selector.** Default=0. If set to 0 the analogue output will carry a signal proportional to motor torque. If set to 1 it carries a value proportional to Pr38.
- b40.12** **Digital/analogue reference selector.** Default=0. If set to 0 the analogue input is selected as the main reference. If set to 1 the reference will be digital and, by means of 40.13, it can be set for internal or external. If set for an external input, using b42.5 this can be set for quadrature or frequency/direction.
- b40.13** **Internal or frequency reference selector.** Default=0. If b40.12=1, b40.13 can be set to 0 to select internal reference, or to 1 to select the frequency input (encoder-in) which, in turn can be configured as frequency/direction or quadrature signal using b42.5.

- b40.14 Serial communication enable.** Default=0. Set this parameter to 1 to enable serial comms.
- b40.15** Reserved. Must remain on zero.
- b41.0 Overspeed.** When the absolute motor speed value exceeds the value set in Pr13, b41.0 is on 1, otherwise it is on 0.
- b41.1 At speed.** With b40.7=0 if the speed difference between motor and reference is lower than Pr14 and higher than Pr15, b41.1 will be 1, otherwise it will be 0. With b40.7=1, if motor speed is lower than Pr14 and higher than Pr15, b41.1 will be 1, otherwise it will be 0.
- b41.2 Zero speed.** If motor speed (Pr0) is zero rpm, b41.2=1, otherwise b41.2=0.
- b41.3 Forward.** If motor speed (Pr0) is positive b41.3=1, otherwise b41.3=0.
- b41.4 Drive Healthy.** If =1 no alarms are present, otherwise =0.
- b41.5 Hardware enable status.** 1 when hardware enable is set.
- b41.6 Temperature pre-alarm.** 10 degrees before reaching the maximum temperature of the power stage, b41.6 is set to 1.
- b41.7 External alarm.** Alarm for user's equipment.
- b41.8 Auxiliary alarm.** Second alarm for user's equipment.
- b41.9 Calibration failed.** b41.9=1 indicates that initial calibration of current offsets has terminated incorrectly.
- b41.10 Speed control saturation.** b41.10=1 when the speed control loop is delivering maximum current.
- b41.11 I<sup>2</sup>T active.** Indicates that Pr36 has reached 100.0 % and therefore the drive is restricting current to the rated value.
- b41.12 Drive enabled.**
- b41.13 Keypad fault.** b41.12=1 if communication between keypad and drive has failed.
- b41.14 External operating mode.** If set to 1 an external operating mode is installed.
- b41.15 External operating mode time slot.** If set to 1 indicates that the external operating mode is controlled at 2 ms intervals otherwise at 512µs.
- b42.0** Selector to configure encoder emulation.
- b42.1** Selector to configure encoder emulation.
- b42.2** Selector to configure encoder emulation.

Pr32 up to 9000 rpm	=====							
Pr32 up to 3500 rpm	=====							
Pr32 up to 875 rpm	=====							
ENCODER OUT	16384	8192	4096	2048	1024	512	256	128
b42.0	0	1	0	1	0	1	0	1
b42.1	0	0	1	1	0	0	1	1
b42.2	0	0	0	0	1	1	1	1

the double line indicates encoder resolutions available in the various speed ranges  
 Default value is 1024

- b42.4 24V over current.** Digital output trip.
- b42.5 Frequency input** (board X6). If set to 1 the frequency input is programmed to receive two phases in quadrature. This is the default. If set to 0 it is enabled to receive a frequency/direction type input.

- b42.6 Torque compensation.** Default=1. When set to 1 torque compensation is implemented to improve linearity of response.
- b42.7** Reserved.
- b99.6 Extended menu enable.** Default=0. Set to 1 to enable the extended menu.
- b99.7 Security.** Default=0. Set to 1 to prevent parameter modification.
- B99.8 Automatic reset undervoltage.** Default =0. if used the backup function, the parameter must be 1, and in this case the undervoltage alarm is automatically reset.
- b99.13 pico-PLC status.** Default=1. If on 1 the PLC program is run, if on zero the program is not run and the PLC instructions can be modified if required.

#### 4.4. Basic commands

To transmit the following commands b99.7 must be on zero. For commands b42.3 and b94.1, b99.6 must be on one.

- b42.3 Re-initialise serial line.** Command to reinitialise the serial line when the communication speed (Pr26) has been modified. In any event, the serial line is initialised when the drive is started up.
- b94.1 Reset main reference offset.** This command automatically sets parameter Pr1 in order to reset any voltage offset on the main analogue reference. This procedure is only possible if the absolute offset value is less than 200 mV.
- b99.9 Current offset calibration request.** The command is accepted only if the drive is disabled. The calibration procedure is executed when the drive is started up.
- b99.10 Alarm reset.** This command resets Pr23 and Pr24; if the alarm persists it is shown on the display. The command is not accepted in the presence of checksum errors (Pr23=10, 11); in this case set default parameters (b99.12) and then reset the alarm. If the backup power supply is present (terminals 8 and 9 on X3), when mains power is restored to the terminals on X4 you must wait 10 seconds before transmitting the undervoltage alarm reset command and enabling the drive.
- b99.11 Operating mode parameter default values.** This command sets current operating parameters to default values. The command is executed only if b40.2 = 0.
- b99.12 Default values.** This command sets all parameters to default values and cancels the values used by the operating modes; it also sets the pico-PLC program as described in appendix G. If a checksum alarm is present, Pr23 and Pr24 are set to zero so that the alarm can be reset. The command is executed only if b99.13 = 0.
- b99.14 Save pico-PLC instructions.** Saves the pico-PLC program. If an error occurs while saving, "retry" is shown on display: in this case transmit the command again.
- b99.15 Save parameters.** Stores all parameters. This command is not possible in the presence of a checksum error; in this case, set default parameters, reset the alarm and then save the new parameterisation settings. If an error occurs while saving, "retry" is shown on display: in this case transmit the command again.

## **4.5. Calibrating speed loop**

### **IMPORTANT CONCEPTS**

**SPEED LOOP:** the main task of any drive is to control motor speed so that it follows, as faithfully as possible, the required speed, which is generally referred to as the **REFERENCE**. High fidelity reproduction of the reference implies that motor speed is identical to reference speed in static conditions and also that it follows speed requirements closely also in the case of sudden changes in the speed reference (dynamic conditions). To perform this task the drive must be informed of various characteristics of the motor and the mechanical system to which the motor is coupled; this type of information is set in the **CALIBRATION PARAMETERS**.

**ERROR:** the error refers to the difference between reference speed and motor speed. The error value is utilised by the speed control loop to calculate (using calibration parameters) how much current to supply to the motor.

**TORQUE:** current flowing through the motor windings is converted into torque which allows the motor to accelerate and decelerate.

**GAIN:** in consideration of the typical applications of the HPD drive, the expression “gain” in this section of the manual refers to “stiffness”. To understand the concept of stiffness imagine a motor controlled by a drive with speed demand of zero rpm. The motor shaft will appear immobile but if we apply torque to the shaft it will rotate through an angle that depends on the amount of torque applied. We can then apply the rated torque of the motor and then measure the “stiffness angle” in degrees. The resulting value provides an indication of the fidelity of the drive thus parametrised, although it is clearly not the only fidelity indicator.

### **WHAT'S NEEDED**

To calibrate an HPD drive correctly we recommend using an oscilloscope with memory. Obviously, the technician in charge must be well versed in the use of the instrument. If it is impossible to use an oscilloscope, we illustrate, at the end of this section of the manual, an alternative although less accurate method.



## BEFORE STARTING

Before starting observe figure 1.

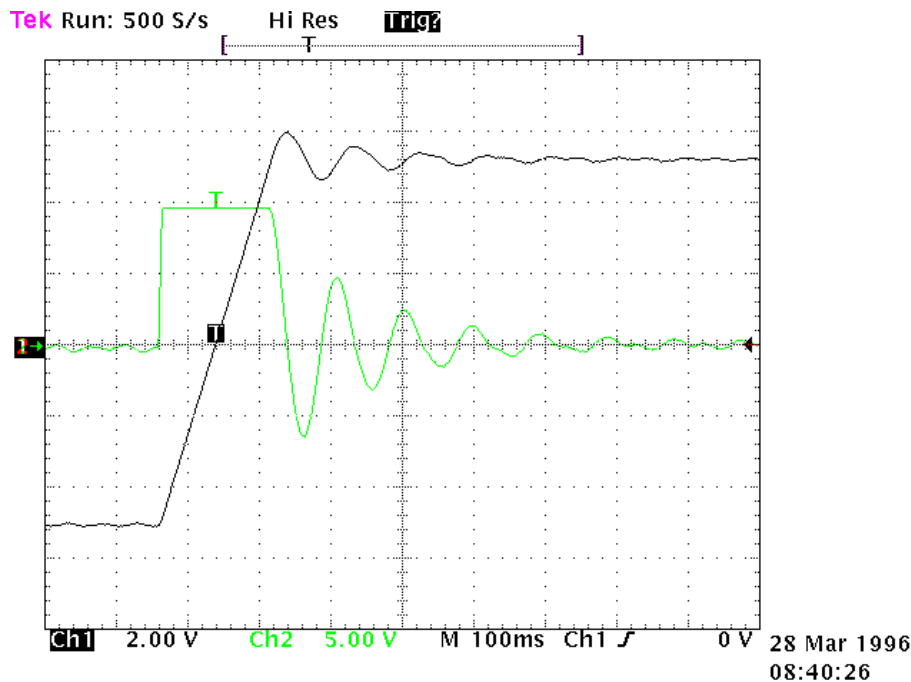

Fig. 1

The graph shows system response to a square wave speed reference. Channel 1 (Ch1) is speed and channel 2 (Ch2) is motor current. The channel 1 oscilloscope probe is connected to terminal 9 of X2 and channel 2 to terminal 7 of X2. The V/div scale and the timebase are not mentioned as they may vary considerably.

## CALCULATING Pr16

The value of Pr16 should be calculated before enabling the drive. Pr16 defines system gain. To convert Pr16 into degrees for rated torque use the formula:  $ac = \frac{Pr33}{Pr16} \cdot 28$  where ac is

the stiffness angle. Obviously, before the formula can be used Pr33 must be set to motor rated current. To evaluate ac correctly we shall consider that, if the driven machine transmission is rigid (not flexible) and there is no transmission backlash, the optimal stiffness angle could be around 4 degrees. If the transmission is not sufficiently rigid it may be necessary to reduce gain. If motor torque has been selected to achieve steep acceleration ramps, while dynamic torque changes in normal operation are minimal, stiffness angles of 20, 30 or 40 degrees are acceptable without negatively affecting performance. If you encounter difficulty in choosing the most appropriate stiffness angle, start from 10 degrees, which is the default value when using a motor with the same rated current as the drive.

Now enter the calculated value for Pr16 and start the motor with a square wave reference signal (pay attention when setting the reference amplitude and frequency to avoid problems in the case of limited stroke axes). On the oscilloscope note that the response changes as Pr17 is altered. Lowering Pr17 will allow you to approach system response as shown in figure 2.

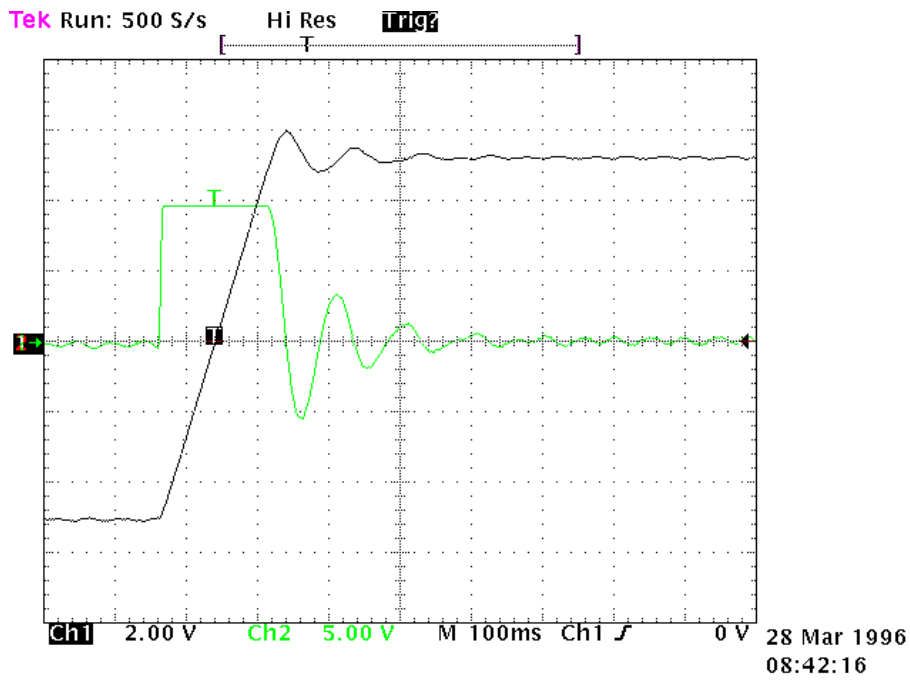

Fig.2

For higher values of Pr17 system response will resemble the situation of figure 3 below.

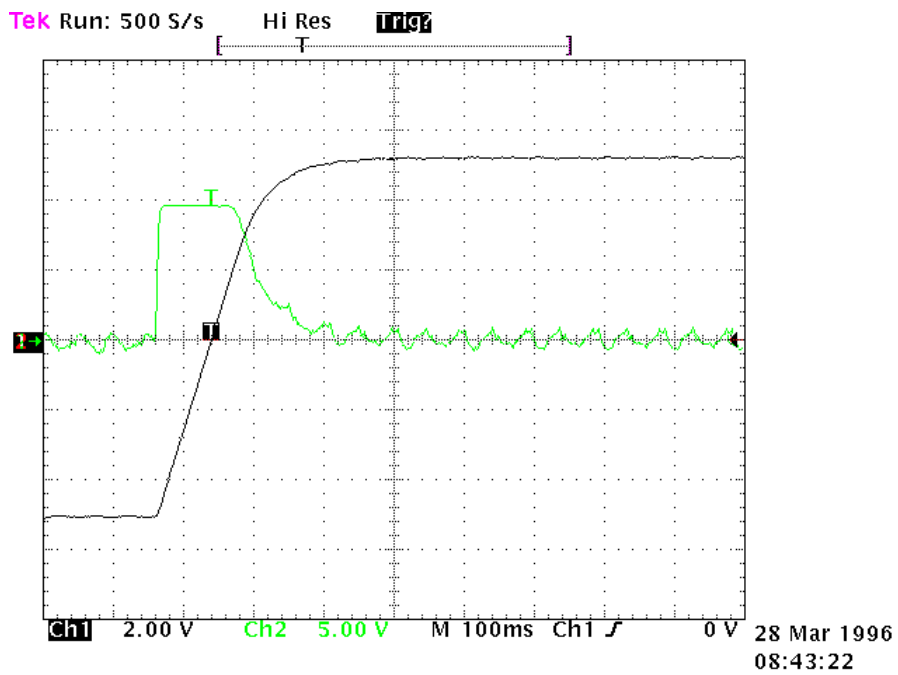

Fig.3

The optimal value of Pr17 can be considered when system response is as shown in figure 4.

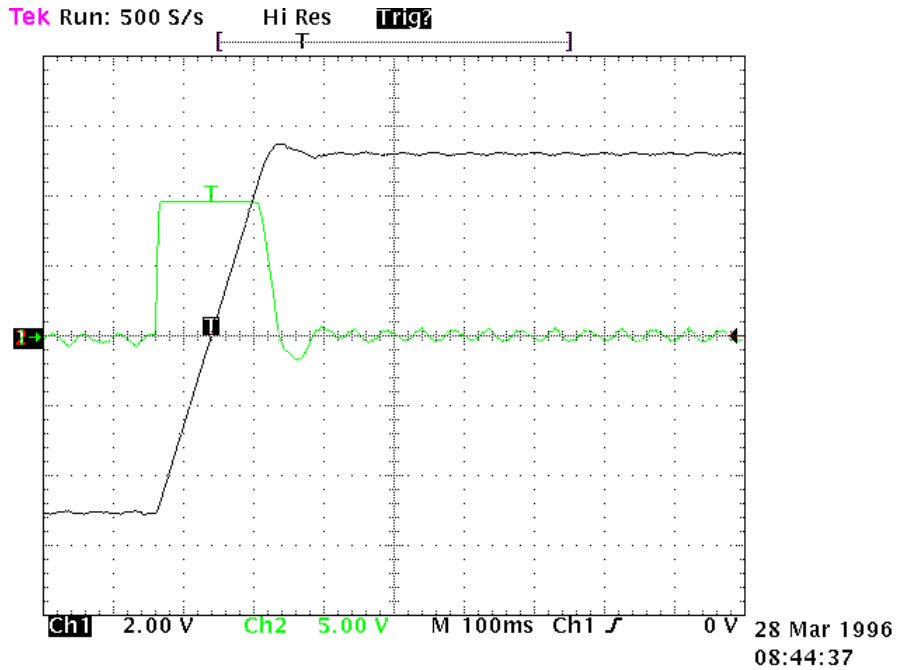

Fig.4

We must therefore obtain approximately 10% overshoot. Make sure that the overshoot is not followed immediately by undershoot.

Once you have set the optimal value for Pr17 pay attention to the movement of the motor shaft: if it moves smoothly without vibration and noise, you can deduce that system calibration procedures are terminated. Otherwise repeat all the previous steps using lower values for Pr16.

In certain applications you can reduce system acoustic noise levels by raising parameter Pr18 by a few points. Fig.5 shows that the optimal system response is accompanied by a current fluctuation that can generate acoustic noise and mechanical vibration; increasing Pr18 to the value 3 will improve this condition significantly (fig. 6).

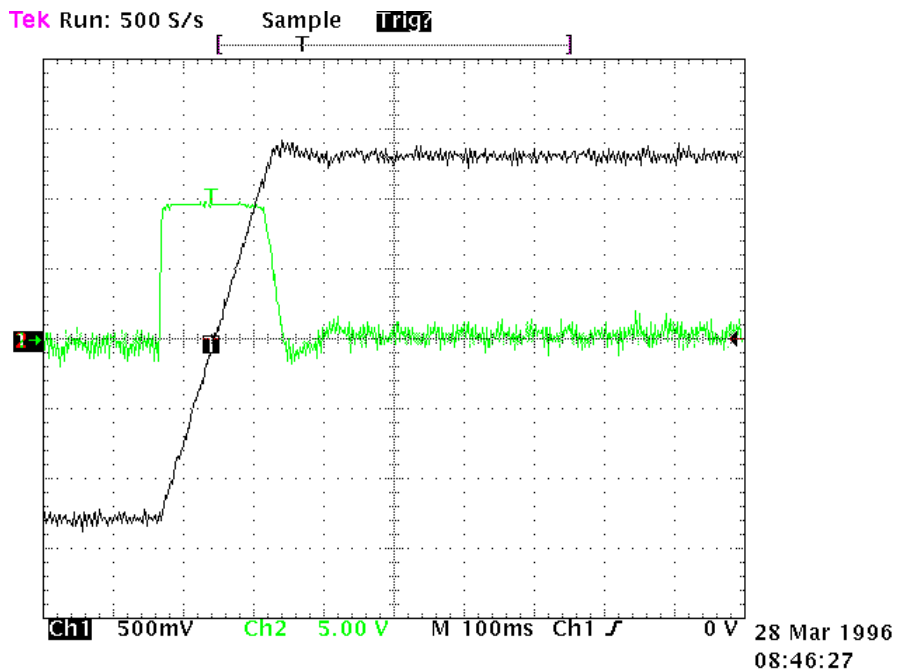

Fig.5

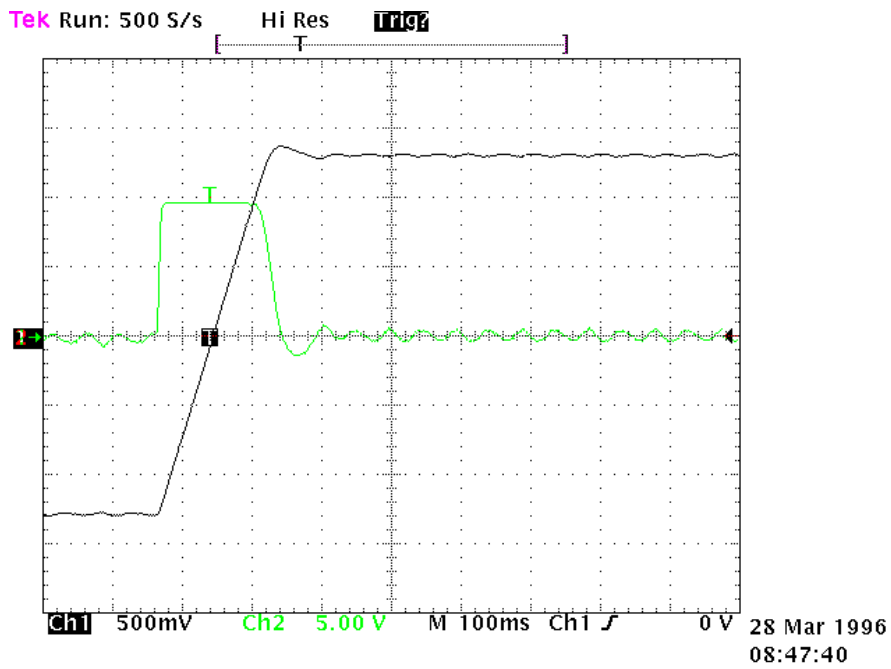

Fig.6

If the driven mechanical system is prone to oscillation, we recommend using very low values for Pr16; in this configuration the HPD drive will smooth out motor torque requests to prevent the creation of mechanical oscillation. Figure 7 shows this type of configuration.

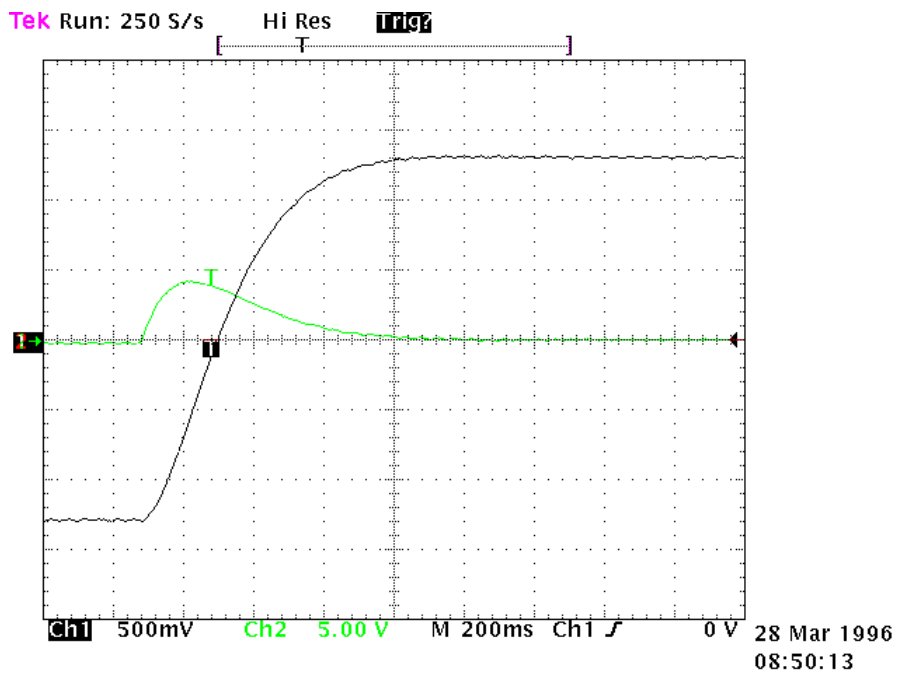

Fig.7

## CALIBRATION WITHOUT INSTRUMENTS

If an oscilloscope is not available, proceed as follows:

- A) Calculate the value of Pr16 as described earlier.
- B) Calculate Pr17 using the following formula:

$$\text{Pr17} = 1488 \cdot \sqrt{\frac{135.41 \cdot \text{Pr16} \cdot J_{\text{tot}}}{\text{Nm}_{\text{peak}}}}$$

where:  $J_{\text{tot}}$  is total inertia (motor + load) in  $\text{kgm}^2$   
 $\text{Nm}_{\text{peak}}$  is available torque with peak current of the system

- C) Start the drive and, moving the axis with an external control change Pr17 to seek the value at which the axis moves as required.
- D) Calculate Pr18 using the following formula:

$$\text{Pr18} = 0.17 \cdot \frac{\text{Pr17}}{\text{Pr16}} \geq 1$$

If the resulting calibration is unsatisfactory, repeat the procedure with lower values for Pr16.

**If the result is <1, Pr18 must be =1.**

## 4.6. Operating modes

Operating modes are selected by means of parameter Pr31, whose default value is 0. Each operating mode commands a speed loop by means of parameter Pr6 and can limit motor torque with parameter Pr21 (see block diagrams). Speed control uses Pr7 or Pr6 as a reference depending on the value of b40.2. Before changing Pr31, b40.2 must be set to 0 to prevent undesired motor movement; it is now possible to set Pr31 to the value of the chosen operating mode and load default parameters by means of parameter b99.11. The operating mode will be enabled by setting b40.2 to 1.

### 4.6.1. Torque control

This operating mode (1) does not perform “classic” torque control because the speed loop remains active to monitor limit speed; the torque reference is the main reference Pr7. To set torque control first program the speed loop to create a stable system. Now set Pr2=1000 (10 V = 100.0 % torque) b40.0=0 & b40.12=0; b40.2=1 to program the reserved reference, Pr31=1 to enable the operating mode and Pr50 for maximum speed.

#### PARAMETERS FOR OPERATING MODE 1

**Pr50** **Maximum speed.** Unit=rpm, default=3000, range=0..9000. This parameter makes it possible to limit maximum absolute motor speed during torque control operation.

### 4.6.2. Acceleration control

Instead of performing closed loop acceleration control, this mode (2) uses main reference Pr7 for dynamic modulation of the ramps. To program analogue acceleration control the first requirement is a stable speed loop. When this is present set Pr2=ACC / 3.2 where ACC is acceleration in rad/s<sup>2</sup> required with a 10V reference signal, b40.0 = 0, b40.12 = 0, b40.2 = 1 and Pr31 = 2. Maximum speed must be programmed in Pr50.

#### PARAMETERS FOR OPERATING MODE 2

**Pr50** **Maximum speed.** Unit=rpm, default=3000, range=0..9000. This parameter makes it possible to limit maximum absolute motor speed during operation with acceleration reference.

**Pr55** **Acceleration/deceleration ramp,** read-only parameter. Unit=s/krpm, range=2..30000, resolution=1 thousandth of a second.

**Pr60:61** Reserved.  
**Pr62:63** Reserved.  
**Pr66:67** Reserved.

### 4.6.3. Low voltage procedure (rel. Sw.41 or more)

This procedure is for those situations in which the operator needs to work in close proximity to the machine in a situation which could be potentially hazardous. In these conditions, the operator must move the axes with a lower voltage than the nominal motor voltage (nominal voltage useable: from 90 to 480V~, low voltage: from 48 to 90V~), so that the top speed of the axes is also lowered.

- Setting the drive:
  1. Store **b40.10=1**
  2. Autoreset under voltage excluded: **b99.8=0**

**Caution:**

The low voltage movement mode is potentially hazardous to the drive when going from low voltage to nominal operating voltage. This passage must always be done with the drive disabled, and it is necessary to follow these instructions step by step.

- Low voltage to nominal operating voltage sequence.
  - a. Disable the drive. Wait 100ms.
  - b. Change the voltage from low to nominal.
  - c. Wait 1sec.
  - d. Enable the drive. The drive will be enabled after about 120ms. The display will say RUN, and the axis is ready to be checked
- Nominal operating voltage to low voltage sequence.
  - a. Disable the drive. Wait 100ms.
  - b. Change the voltage from nominal to low.
  - c. Wait 1sec.
  - d. Enable the drive. The drive will be enabled after about 120ms. The display will say RUN, and the axis is ready to be checked

If during these sequences the display shows the error message ERR2, send the reset command **b99.10=1**.

In the previous releases, this procedure only works if there is no backup, and you must wait for the drive to shut off in the passage from low voltage to nominal voltage and vice versa.

#### 4.6.4. Maintenance and commissioning

This operating mode is designed to assist technical personnel during commissioning.

Mode 8 provides various tests to check drive wiring. It's also possible to move the shaft manually by means of Pr50, b70.1 and b70.2 or using the internal profile generator, which simplifies speed control loop set-up and ensures that there is no overrun on the programmed movement. Programming parameters for generating internal profiles are: speed, motor revolutions, starting position and interval, in seconds, between forward and reverse movement.

To perform the wiring test the motor must be disconnected from all loads, including inertia loads; disable the drive via software (b40.9=0), Pr30 must be zero, enable the drive via hardware and set b70.3=1. The drive will now execute the test routine. When terminated (b70.3=0), the error code in Pr56 can be displayed after setting Pr57=0.

Error codes:

0	no error
1	b40.9=1 or drive disabled via hardware
2	motor phase sequence and resolver direction incompatible
3	number of motor poles and Pr29 incompatible
4	resolver phase error
5	Pr30 value not zero
99	procedure aborted

By setting the various values in Pr57 you can get other useful information for installation and maintenance (see table in block diagrams).

#### **PARAMETERS FOR OPERATING MODE 8**

- Pr50 Manual speed.** Unit=rpm, default=100. This speed value is used for manual movements executed using b70.1 , b70.2 with b70.0=0 and b40.2=1.
- Pr51 Profile execution speed.** Unit=rpm, default=1000. This is the speed at which the trapezoidal profile is executed.
- Pr52 Distance.** Unit=revolutions, default=30. This is the number of revolutions of the motor shaft that must be performed during generation of the profile.
- Pr53 Starting point.** Default=1. If set to 1, at start profile (b70.0) the motor will start rotating and execute Pr52 revolutions with positive speed. If set to 2 the motor will start rotating and execute Pr52 / 2 revolutions with positive speed. If you set 3 the motor will start and execute Pr52 revolutions at negative speed.
- Pr54 Pause.** Unit= tenths of a second, default=1. During execution of the profile the drive stops between positive speed movement and negative speed movement for an interval of Pr54 at zero rpm.
- Pr55 Deviation factor.** During execution of the profile, assuming the same value of Pr16 the optimal value of Pr17 can be achieved by minimising the value of Pr55.
- Pr56 Value.** Returns information requested with Pr57.
- Pr57 Information request.** This parameter serves to query the drive. A table of queries is shown in the block diagram of operating mode 8.
- Pr58** Reserved.
- Pr59** Reserved.



**Pr60:61** Reserved.

**Pr62:63** Reserved.

**Pr64:65** Reserved.

**Pr66:67** Reserved.

**Pr68:69** Reserved.

**b70.0 Start profile.** Set 1 to execute the programmed profile. Remember to set b40.2=1 to effectively switch the speed reference to the control loop.

**b70.1 Manual forward speed.** If at 1 with b70.0=0 and b40.2=1, the shaft will rotate at the speed programmed in Pr50.

**b70.2 Manual reverse speed.** If at 1 with b70.0=0 and b40.2=1, the shaft will rotate at the speed programmed in Pr50 but in the opposite direction.

**b70.3 Wiring test.** When you set this command the drive performs a test procedure and returns the result as an error code that can be viewed using parameters Pr56 and Pr57. Before entering this command, make sure the motor is disconnected from all loads, even pure inertia loads. Also ensure that b40.9=0.

**b70.4** Reserved.

**b70.5 Vibration test.** If none of the above functions is active, you can set this bit to one to evaluate the vibration of the motor shaft, incrementing parameter Pr64 in absolute terms by a value proportional to the vibration detected. The user is responsible for evaluating Pr64 and bringing it to zero in relation to the appropriate time interval.

**b70.6** Reserved.

**b70.7** Reserved.

**b70.8** Reserved.

#### 4.6.5. Positioner

Operating mode 9 executes a simple trapezoidal profile. For this profile the user must define acceleration with Pr51, steady time rpm with Pr52 and displacement using the pair of long format parameters Pr64 and Pr65. At each profile execution command, b70.8, the motor executes Pr64:65 steps (one motor revolution is equivalent to 4096 steps). The parameters of a trapezoidal profile cannot be changed during execution (b70.7=1), except Pr64:65. In the block diagram note the four different reset types, the availability of servo-error indication and the possibility of using space control with or without feed forward. The incremental position must be always positive and movement direction must be selected with parameter b70.1. Displacement can be defined using the drive frequency input. Additional features are available using the internal PLC.

Note that the profile execution command is not generated on a constant time base (profile calculation may require more than 2 milliseconds).

**PARAMETERS FOR OPERATING MODE 9**

- Pr50 Pulse input multiplication factor K.** Default=1. If b70.9=1 frequency/direction input pulses are multiplied by Pr50 and the result is added to Pr64:65. The frequency input direction signal must be forced to a fixed level (logical 0). Refer to the chapter *Frequency input connection* for the connection diagrams.
- Pr51 Acceleration time.** Unit=s/krpm, range=0.002..30.000, resolution=0.001 sec, default=0.002 S. Acceleration ramp for positioning profile.
- Pr52 Rpm at speed.** Unit=rpm, default=1000. Steady state speed used during generation of the positioning profile.
- Pr53** Reserved.
- Pr54** Reserved.
- Pr55** Reserved.
- Pr56 Servo-error window.** Unit=steps, default=100. If the position error as an absolute value exceeds the value set in Pr56, b70.5 is set to 1. If b70.5 is utilised it must be reset by the user following servo errors. This can be achieved, for example, by the PLC program.
- Pr57 Position controller proportional gain.** Default=100, range 0..32000.
- Pr58** Reserved.
- Pr59** Reserved.
- Pr60:61 Position controller reference.** Unit=steps.
- Pr62:63 Motor position.** Unit=steps, 4096 steps per revolution.
- Pr64:65 Incremental position.** Unit=steps. On receipt of the profile request, b70.8, the motor will execute Pr64:65 steps in the direction set in b70.4.
- Pr66:67** Reserved. Cannot be used during profile generation.
- Pr68:69** Reserved. Cannot be used during profile generation.
- b70.2 Reset incremental position.** Resets Pr64:65. This command is useful when the incremental value is programmed on the frequency input.
- b70.4 Forward/Reverse.** When the start profile command is transmitted (b70.8) if b70.4=0 the motor will execute Pr64:65 steps in the positive speed direction. If b70.4=1 it will execute the same number of steps in the negative speed direction.
- b70.5 Servo error.** b70.5 is set to 1 if the absolute value of the position error is greater than the value set in Pr56. If utilised, b70.5 must be reset by the user, e.g. using the PLC program, following servo-errors.
- b70.6 Feed-forward enable.** Default=0. If set to 1 feed-forward is enabled on the position controller.
- b70.7 Profile in execution.** B70.7=1 indicates that the drive is executing a positioning profile.
- b70.8 Start profile.** To start positioning.
- b70.9 Enable frequency input.** Default=0. If set to 1, Pr64:65 can be set on the frequency input.
- b70.10 Reset type 1.** Resets motor and reference position. This command is only accepted when no profile is in execution.
- b70.11 Reset type 2.** Command to set motor and reference position to equal the absolute position of the shaft. Accepted only when no profile is in execution.

- b70.12 Reset type 3.** Command to set the reference equal to the motor position. Accepted only when no profile is in execution.
- b70.13** Reserved.
- b70.14** Reserved.
- b70.15** Reserved.

#### 4.6.6. Digital locking

Operating mode 10 is a tracking function referred to a frequency input signal (connector X6) set as an encoder signal with b42.5=1; the encoder signal is counted on all A and B signal switching fronts. The motor position counter increases by 4096 steps each revolution. The ratio between master and slave can be entered using parameters Pr51 and Pr53. You can also select the ramp to utilise during catch or release cycles (Pr52), add slip speed (Pr58) and limit speed demands of the proportional part of the loop (Pr50). Further information available: master and slave locked and servo-error. Using Pr52, the main ramps and the internal PLC makes it possible to program various different catch and release modes with or without phase recuperation. Refer to *Frequency input connection* chapter for connection diagrams.

#### PARAMETERS FOR OPERATING MODE 10

- Pr50 Maximum speed.** Unit=rpm, default=200, range =0..9000. This parameter makes it possible to limit maximum speed of the motor; it can be used to limit speed during a catch on fly cycle or during sudden speed changes (see Pr58).
- Pr51 Reference multiplication factor.** Default=1, range =-32000..+32000. This parameter, together with Pr53, makes it possible to set the required ratio for the input reference frequency.
- Pr52 Acceleration/deceleration ramp.** Unit=s/krpm, default=500, range=0..30000, resolution=1 thousandth of a second. The acceleration/deceleration demanded of the motor can be restricted so that a speed decrease or increase of 1000 rpm takes Pr52 thousandths of a second; this function is useful during catch on fly cycles.
- Pr53 Reference division factor.** Default=1, range=-32000..+32000. This parameter together with Pr51 makes it possible to set the required ratio for the input reference frequency.
- Pr54** Reserved.
- Pr55 Required speed.** Unit=rpm Read-only parameter. Shows the input reference frequency converted into rpm
- Pr56 Servo-error window.** Unit=steps, default=100. If the absolute value of the position error exceeds the value set in Pr56, b70.5 is set to 1. If utilised, b70.5 must be reset by the user, e.g. by the PLC program, following servo-errors.
- Pr57 Position controller proportional gain.** Default=100, range 0..32000.
- Pr58 Slip speed.**

**Pr59** Reserved.

**Pr60:61 Position controller reference.** Unit=steps.

**Pr62:63 Motor position.** Unit=steps, 4096 steps per revolution.

**Pr64:65** Reserved.

**Pr66:67** Reserved.

**Pr68:69** Reserved.

**b70.2 Digital locking engaged.** During locking with ramp (Pr52) other than zero, this bit indicates the termination of the transitional phase.

**b70.3 Enable position.** Default=0. During unlocking b70.3=1 enable position with Pr61:60.

**b70.5 Servo-error.** b70.5 is set to 1 if the absolute value of the position error exceeds the value set in. If utilised, b70.5 must be reset by the user, e.g. by the PLC program, following servo-errors.

**b70.6 Feed-forward.** Default=1. If set to 1 feed-forward is enabled on the position controller.

**b70.8 Axis lock/release.** With this bit you can lock (=1) or release (=0) the axis from the input encoder reference.

**b70.9** Reserved.

**b70.10 Reset type 1.** Resets motor and reference position. Implemented only with b70.8=0.

**b70.15** Reserved.

#### 4.6.7. Stepper motor emulation

This mode emulates the operation of a stepper motor: each pulse received on the frequency input (terminal board X6 channel A=frequency, channel B=direction) is multiplied by Pr51 and the result is added to the reference position. The frequency input must be programmed as a direction/sign signal by setting b42.5=0. Just as in all other operating modes it is possible to enable feed forward, limit the action of the proportional part, obtain servo-error indication and select the most suitable type of reset. Note that the frequency count occurs on the negative front of the signal and changes of the direction signal must be made at least 1  $\mu$ S before the negative frequency front. Unlike stepper motors, in this case there is no risk of step loss. Refer to *Frequency input connection* chapter for the connection diagrams.

#### PARAMETERS FOR OPERATING MODE 11

**Pr50 Maximum speed.** Unit=rpm, default=3000, range=0..9000. This parameter makes it possible to limit maximum motor speed.

**Pr51 Reference multiplication factor.** Default=1, range=-0..+4096. This parameter allows you to set the required multiplication ratio for input reference frequency.

**Pr54** Reserved.

**Pr56 Servo-error window.** Unit=steps, default=100. If the absolute position error is greater than the value in Pr56, b70.5 is set to 1. If utilised, b70.5 must be reset by the user, e.g. by the PLC program, following servo-errors.

**Pr57 Position control loop proportional gain.** Default=100, range 0..32000.

**Pr60:61 Position control loop reference.** Unit=steps.

**Pr62:63 Motor position.** Unit=steps, 4096 steps per revolution.

**Pr64:65** Reserved.

**b70.5 Servo-error.** b70.5 is set to 1 if the absolute position error is greater than the value in Pr56. If utilised, b70.5 must be reset by the user, e.g. by the PLC program, following servo-errors.

**b70.6 Feed-forward enable.** Default=0. If set to 1 feed-forward is enabled on the position controller.

**b70.8 Axis lock/release.** With this bit you can lock (=1) or release (=0) the axis from the input encoder reference.

**b70.9** Reserved.

**b70.10 Reset type 1.** This command resets motor and reference position.

**b70.11 Reset type 2.** Sets motor and reference position equal to the absolute shaft position.

**b70.12 Reset type 3.** Sets the reference equal to the motor position.

#### 4.6.8. Spindle orientation

When this mode (12) is selected it becomes operational when b40.2=1. The motor reaches the speed in Pr50 on the ramps in Pr52. It now spins at constant speed until it reaches the position set in Pr54; at this point the position loop is closed.

#### PARAMETERS FOR OPERATING MODE 12

- Pr50** **Maximum speed during spindle orientation.** Unit=rpm, default=200, range=0..500. This parameter makes it possible to limit maximum motor speed during spindle orientation.
- Pr51** Reserved.
- Pr52** **Deceleration ramp.** Unit=s/krpm, default=500, range=2..30000, resolution=1 thousandth of a second. When the spindle orientation command is set (b40.2=1) deceleration required of the motor can be limited by this parameter so that a change of 1000 rpm takes Pr52 thousandths of a second.
- Pr53** Reserved.
- Pr54** **Motor shaft position for spindle orientation.** Unit=steps, default=0, range=0..4095. One revolution of the motor shaft corresponds to 4096 steps.
- Pr56** **Servo-error window.** Unit=steps, default=100. If the absolute position error is greater than the value set in Pr56, b70.5 is set to 1.
- Pr57** **Position control loop proportional gain.** Default=100, range = 0..32000.
- Pr58** Reserved.
- Pr59** Reserved.
- b70.5** **Servo-error.** b70.5 is set to 1 if the absolute position error is greater than the value in Pr56, otherwise it is set to zero.

#### 4.7. Block diagrams

The main block diagram provides a graphic description of how to use the drive. Each rectangular block represents one or more read/write parameters, each rhomboid shape represents read-only parameters. In the diagram there are other functional blocks such as: greater than..., equal to, the smallest among..., logical and/or; we have used standard symbols for all these blocks. Binary parameters are shown as switches and the position depicted is the default value.

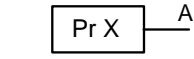

- Read/write parameter PrX  
A = value of PrX

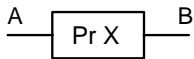

- Read/write parameter PrX  
B = value according to values of A and PrX

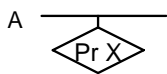

- Read-only parameter  
PrX is value of A (can also be binary)

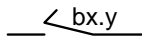

- Read/write bit parameter  
switch position shows  $bx.y=0$

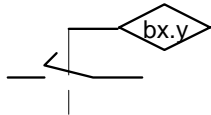

- Value of bit parameter  $bx.y$  sets the switch

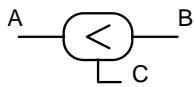

- If A is smaller than B,  $C = 1$  (true); otherwise  $C = 0$  (false)

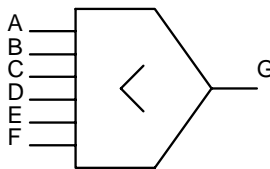

- The value of G is the lower value among A B C D E and F

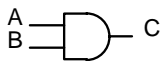

- $C = 1$  only when  $A = 1$  and  $B = 1$ ; otherwise  $C = 0$



- If A or B are 1,  $C = 1$   
otherwise  $C = 0$

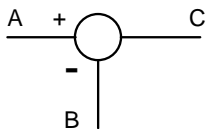

- $C = A - B$



- values from hardware



- values to hardware



- Value of A is converted to B. E.g., if the triangle symbol contains A/D, the analogue value of A is converted into the digital value B

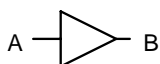

- Maximum value of A is PrX

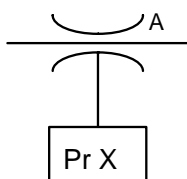

# HIGH PERFORMANCE DRIVE MAIN BLOCK DIAGRAM

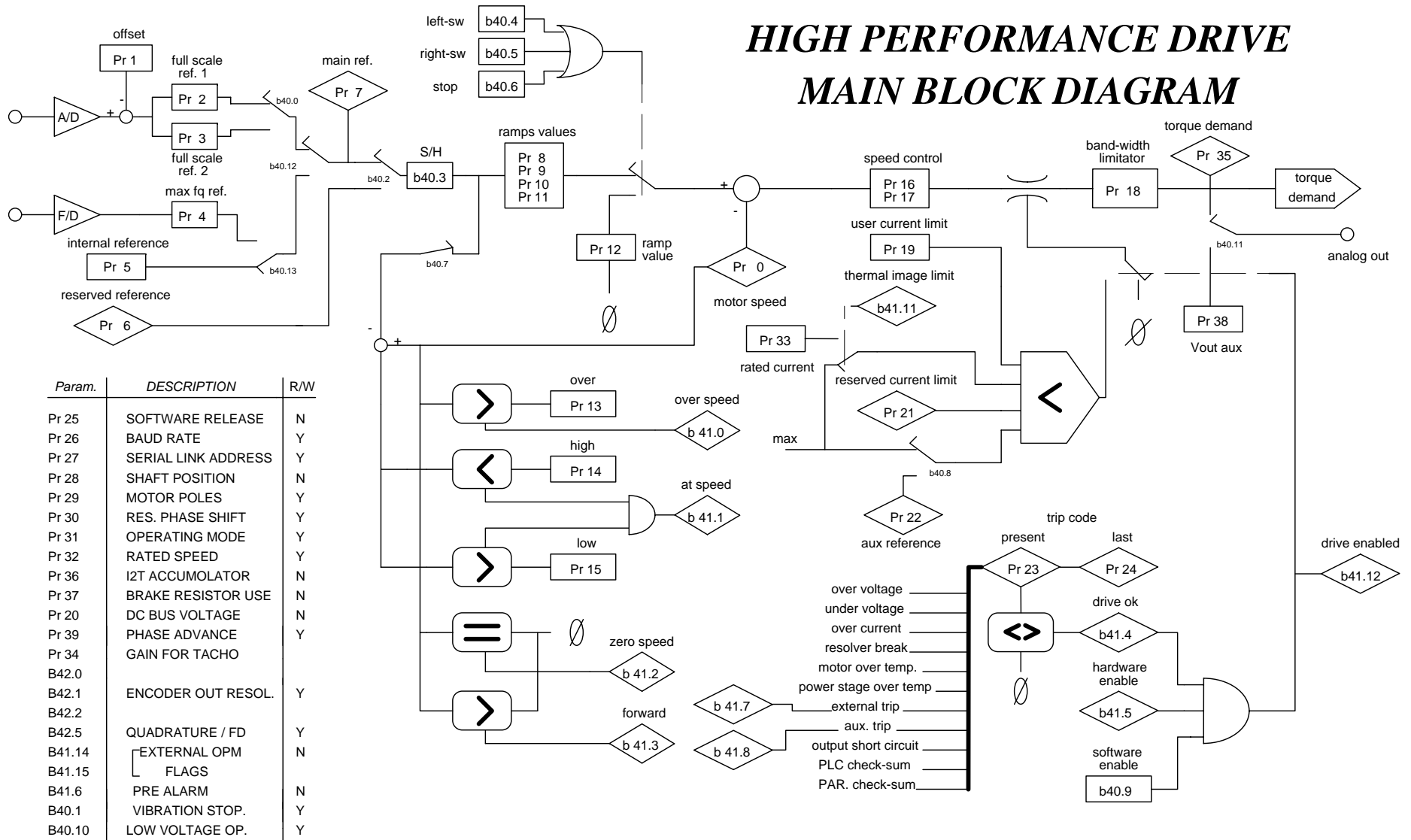

Param.	DESCRIPTION	R/W
Pr 25	SOFTWARE RELEASE	N
Pr 26	BAUD RATE	Y
Pr 27	SERIAL LINK ADDRESS	Y
Pr 28	SHAFT POSITION	N
Pr 29	MOTOR POLES	Y
Pr 30	RES. PHASE SHIFT	Y
Pr 31	OPERATING MODE	Y
Pr 32	RATED SPEED	Y
Pr 36	I2T ACCUMOLATOR	N
Pr 37	BRAKE RESISTOR USE	N
Pr 20	DC BUS VOLTAGE	N
Pr 39	PHASE ADVANCE	Y
Pr 34	GAIN FOR TACHO	Y
B42.0		
B42.1	ENCODER OUT RESOL.	Y
B42.2		
B42.5	QUADRATURE / FD	Y
B41.14	EXTERNAL OPM	N
B41.15	FLAGS	
B41.6	PRE ALARM	N
B40.1	VIBRATION STOP.	Y
B40.10	LOW VOLTAGE OP.	Y



### REFERENCE SELECTION

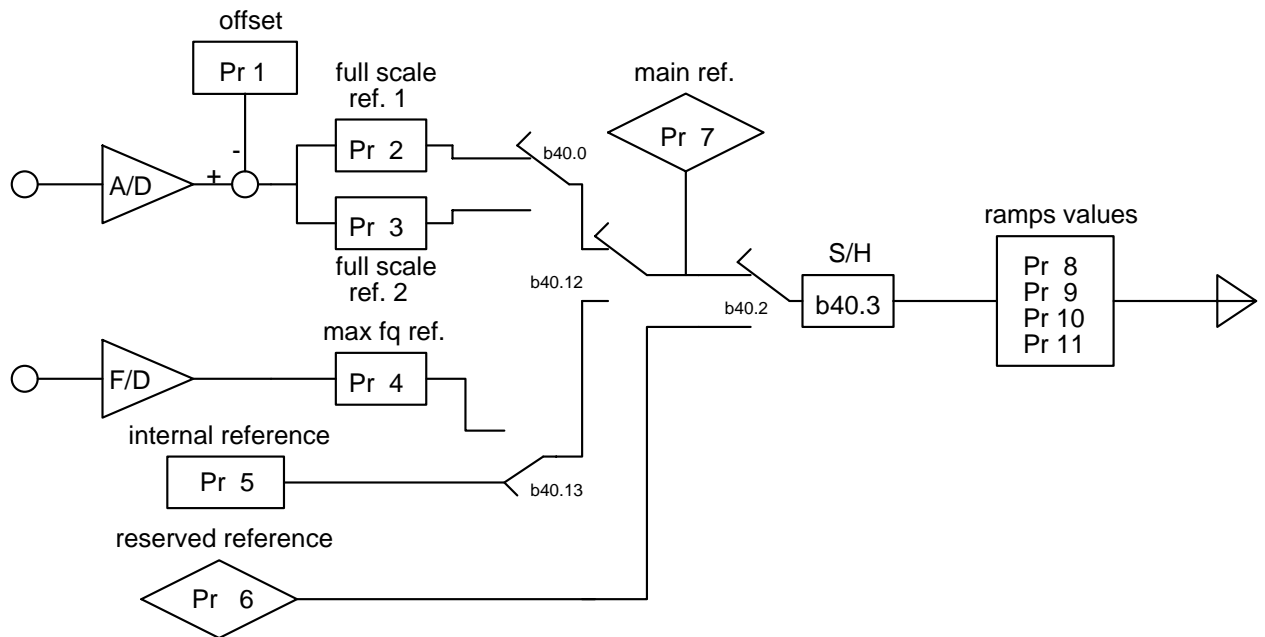

# 1

## **TORQUE CONTROL OPERATING MODE**

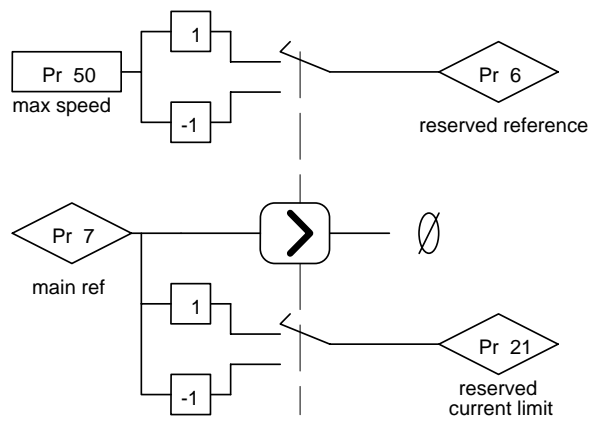

# 2

## ACCELERATION CONTROL OPERATING MODE

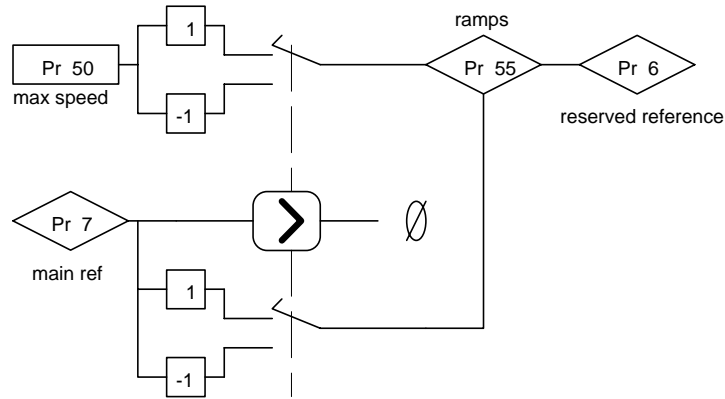

# 8

## MAINTENANCE & COMMISSIONING OPERATING MODE

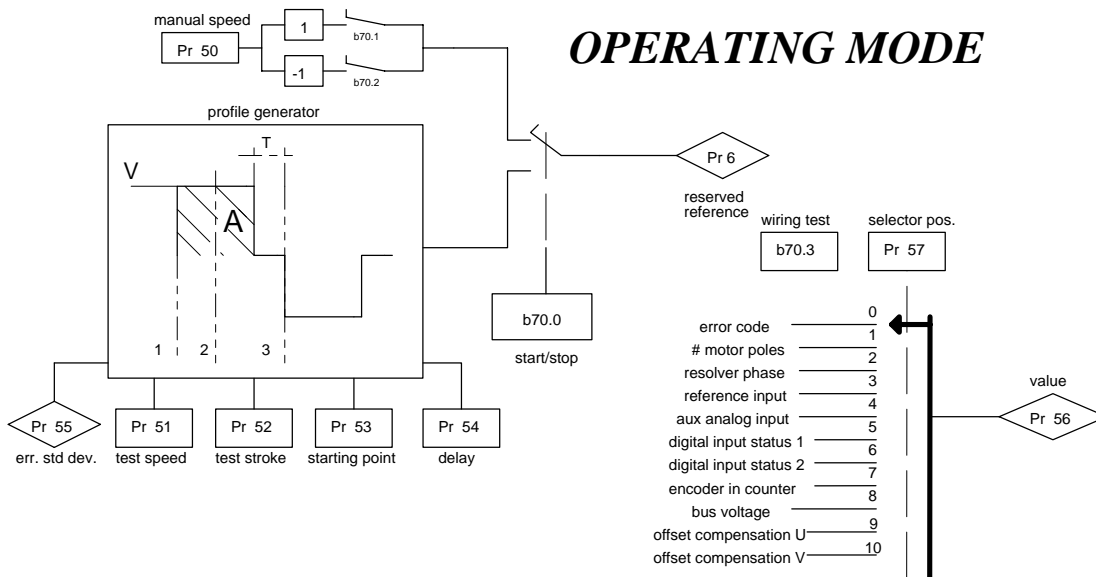

# 9

## TRAPEZOIDAL POSITIONER OPERATING MODE

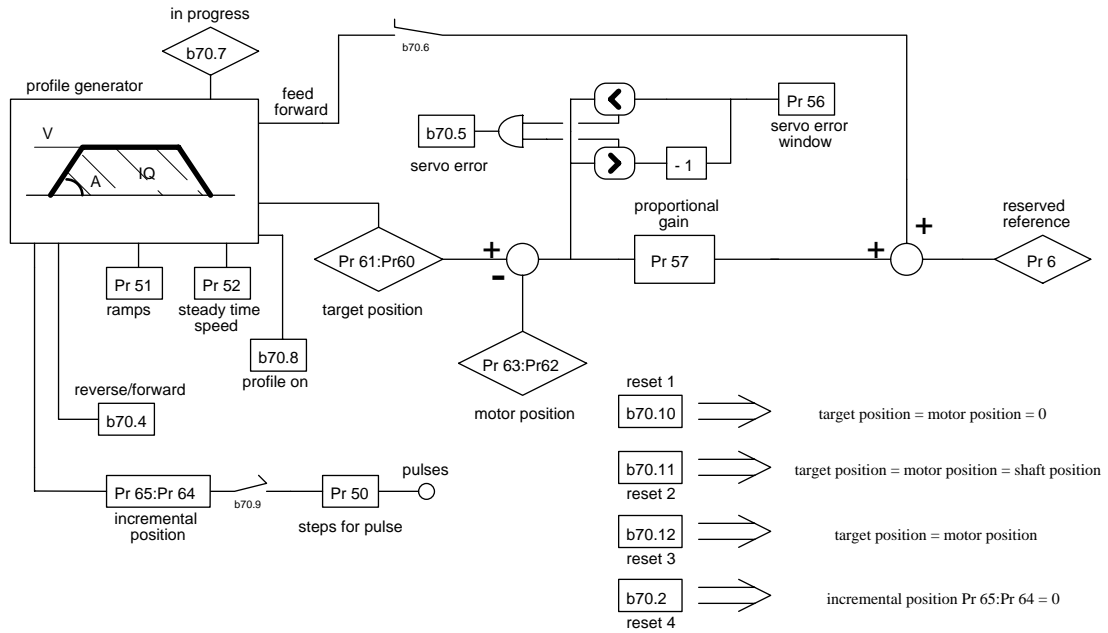

# 10

## DIGITAL LOCK OPERATING MODE

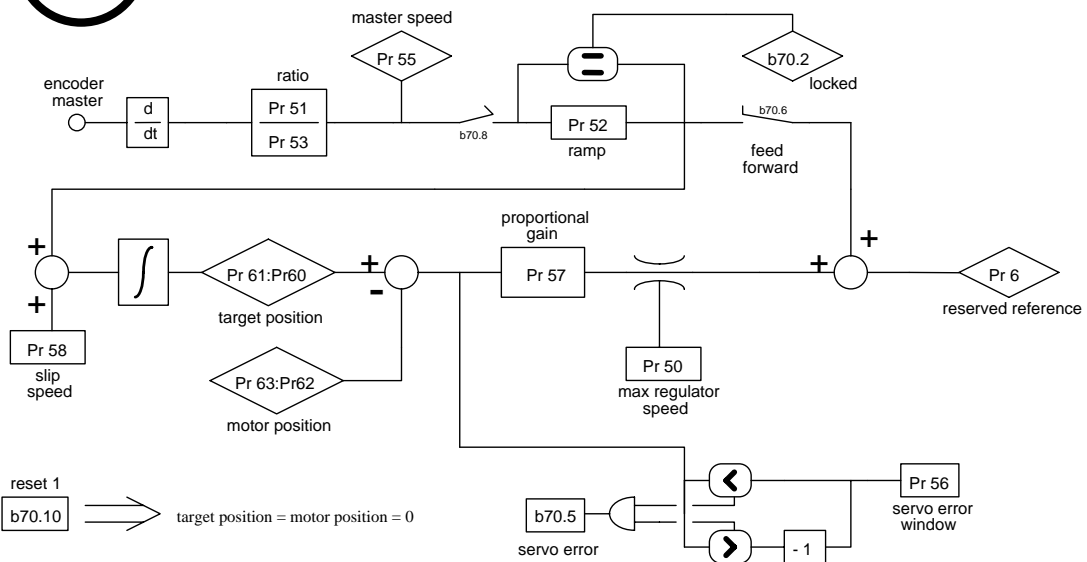

11

**STEPPER LIKE OPERATING MODE**

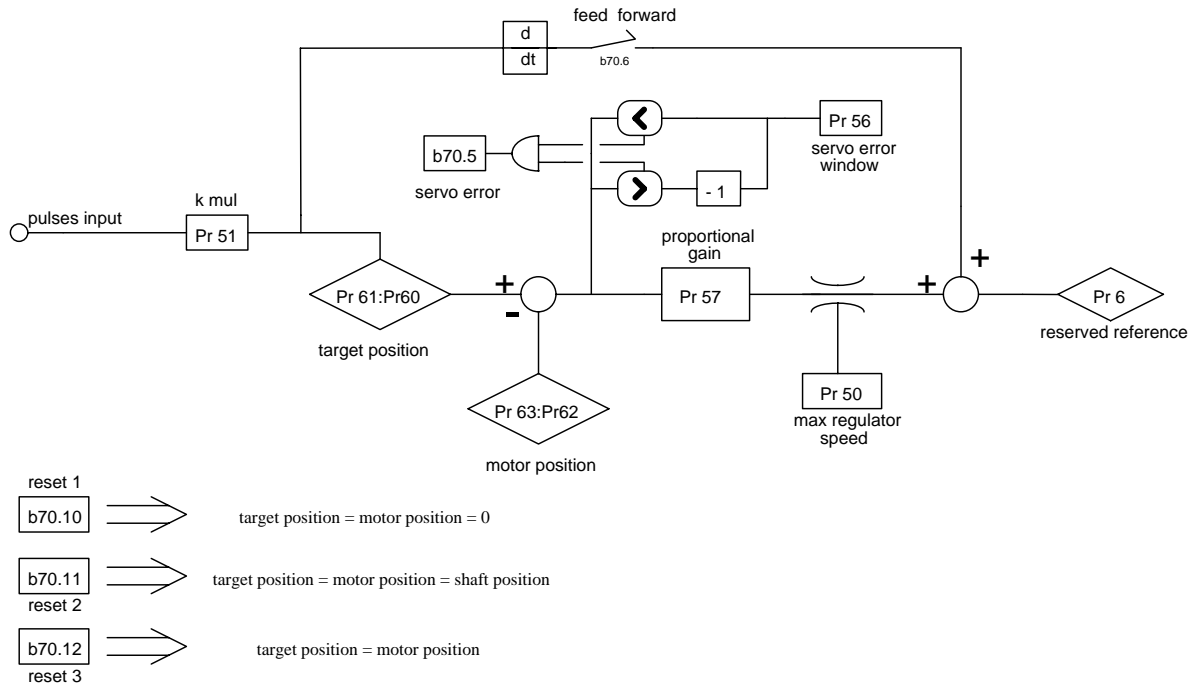

**SPINDLE ORIENTATION OPERATING MODE**

12

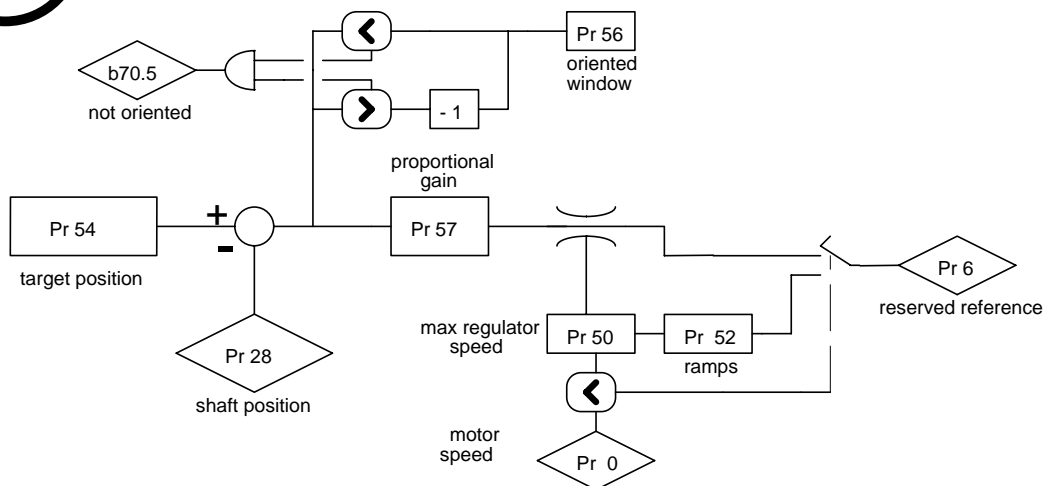

## 4.8. Digital input and output programming

### 4.8.1. Pico-PLC

The internal pico-PLC makes it possible to connect peripheral systems (inputs/outputs) to the parametric system of the HPD drive. The PLC can be used to copy a digital input into a bit parameter, copy a bit parameter into a digital output and perform mathematical and boolean calculations. The PLC program must be entered as a list of instructions from the keypad; alternatively the PLC can be programmed with the ladder diagram system using a PC on the serial line with an interface such as Pcbrush. Default parameterisation (b99.12) provides a PLC program (see appendix G) designed to fill the requirements of the broadest possible range of applications, therefore it is not necessary to reprogram the PLC in the majority of cases.

Main features of the PLC:





<b>Program steps</b>	<b>64</b>
<b>scan time</b>	<b>6.144 ms</b>
<b>timers</b>	<b>2</b>
<b>instructions</b>	<b>15</b>
<b>stack depth</b>	<b>1</b>
<b>mathematic operations</b>	<b>16 / 32 bits</b>
<b>fast inputs (fast copy)</b>	<b>3 - (512 µs)</b>

### PLC PARAMETERS

- Pr71** Constant value = **-1**. Double word.
- Pr72** Constant value = **0**. Double word.
- Pr73** Constant value = **1**. Double word.
- Pr74** Constant value = **2**. Double word.
- Pr75** Constant value = **10**. Double word.
- Pr76** Constant value = **100**. Double word.
- Pr77** Constant value = **1000**. Double word.
- Pr78** Constant value = **1024**. Double word.
- Pr79** Constant value = **4096**. Double word.
- Pr80** Free parameter. Parameter with save facility at user's disposal (word).
- Pr81** Free parameter. Parameter with save facility at user's disposal (word).
- Pr82** Free parameter. Parameter with save facility at user's disposal (word).
- Pr83** Free parameter. Parameter with save facility at user's disposal (word).
- Pr84** Free parameter. Parameter with save facility at user's disposal (word).
- Pr85** Free parameter. Parameter with save facility at user's disposal (word).
- Pr86** Free parameter. Parameter with save facility at user's disposal (word).
- Pr87** Free parameter. Parameter with save facility at user's disposal (word).
- Pr88** Free parameter. Parameter with save facility at user's disposal (word).
- Pr89** Free parameter. Parameter with save facility at user's disposal (word).

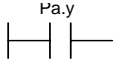
- b90.X Digital input X status.** If X is greater than 7, parameter with save facility at user's disposal (b90.0 = drive enable).
- b91.Y Digital input Y status.** If Y is greater than 7, parameter with save facility at user's disposal. Parameter Pb91 is not saved at power up and is definitely at zero.
- Pr92 First PLC timer.** Every 6.144 ms if Pr92 is not at 0 the timer is decreased, if set to zero b99.0 is set at 1.
- Pr93 Second PLC timer.** Every 6.144 ms if Pr93 is not at 0 the timer is decreased, if set to zero b99.1 is set to 1.
- b94.0 Forces a double word formatted operation.** When the drive is powered up this parameter is on zero. If it is on one, the first mathematical operation of the pico-PLC is executed setting the three operands as double word type; after the operation is executed b94.0 is automatically set to zero.  
If Pr60..Pr68 are utilised, double word formatting is automatic (see text).
- b94.5 Disables the first fast input** (b94.5=0). Set to zero at power-up.
- b94.6 Disables the second fast input** (b94.6=0). Set to zero at power-up.
- b94.7 Disables the third fast input** (b94.7=0). Set to zero at power-up.
- b99.0 First timer status.** At 1 if Pr92 = 0
- b99.1 Second timer status.** At 1 if Pr93 = 0
- b99.2** At 1 if the result of the last PLC operation is negative.
- b99.3** At 1 if the result of the last PLC operation is zero.
- b99.13 PLC status.** Default=1. If set to 1 the PLC program is executed, if on zero the program is not executed and modification of PLC instructions is enabled.

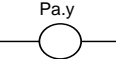
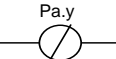
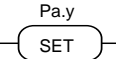
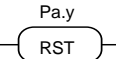
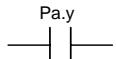
**PLC INSTRUCTIONS**

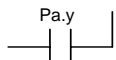
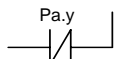
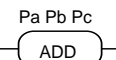
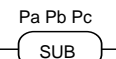
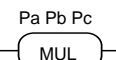
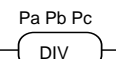
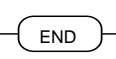
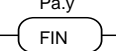
	<b>LD</b>	<b>Pa,y</b>	load bit y of parameter Pa in the stack
	<b>LDN</b>	<b>Pa,y</b>	load inverted bit y of parameter Pa in the stack
	<b>OUT</b>	<b>Pa,y</b>	set bit y of parameter Pa to the value loaded in the stack
	<b>OUTN</b>	<b>Pa,y</b>	set bit y of parameter Pa to the stack value and invert it
	<b>SET</b>	<b>Pa,y</b>	if stack is at 1, set bit y of parameter Pa to 1
	<b>RES</b>	<b>Pa,y</b>	if stack is at 1, set bit y of parameter Pa to zero
	<b>AND</b>	<b>Pa,y</b>	the bit loaded into the stack assumes the result of the logical AND operation between itself and bit y of parameter Pa
	<b>ANDN</b>	<b>Pa,y</b>	the stack bit assumes the result of the logical AND between itself and inverted bit y of parameter Pa
	<b>OR</b>	<b>Pa,y</b>	the bit loaded into the stack assumes the result of the OR between itself and bit y of parameter Pa
	<b>ORN</b>	<b>Pa,y</b>	the stack bit assumes the result of the OR between itself and inverted bit y of parameter Pa
	<b>ADD</b>	<b>Pa, Pb, Pc</b>	if stack bit is at 1, parameter sum operation is executed, therefore: $Pc = Pa + Pb$
	<b>SUB</b>	<b>Pa, Pb, Pc</b>	if stack bit is at 1, subtraction operation is executed on parameters, therefore: $Pc = Pa - Pb$
	<b>MUL</b>	<b>Pa, Pb, Pc</b>	if stack bit is at 1, multiplication operation is executed on parameters, therefore: $Pc = Pa \cdot Pb$
	<b>DIV</b>	<b>Pa, Pb, Pc</b>	if stack bit is at 1, division operation is executed on the parameters, therefore: $Pc = Pa / Pb$
	<b>END</b>		program end
	<b>FIN</b>	<b>y, 0/1</b>	fast scanning input

## OPERATIONAL DESCRIPTION

The pico-PLC program is scanned every 6.144 msec; at each sampling first the inputs are read, then the two timers are updated (Pr92 Pr93 b99.0 and b99.1), the user program is scanned, and finally the outputs are updated. Therefore, reading of the inputs and output updates can deviate temporally by up to 6.144 ms with respect to the physical event.

All pico-PLC instructions with the exception of mathematical instructions, operate on single bits; moreover, available stack depth is a single bit.

Instruction LD (LDN) loads the bit defined as operand into the stack, while all other logical instructions operate on the stack. Mathematical operations are executed only if the stack bit is at 1.

The following logic operations truth tables are provided for the user's convenience:

logical AND operations		
bit A	bit B	result
0	0	0
0	1	0
1	0	0
1	1	1

logical OR operations		
bit A	bit B	result
0	0	0
0	1	1
1	0	1
1	1	1

The relative inverted ANDN and ORN operations follow the same logic, except they use the inverted value of the specified bit.

There are 8 bits with save facility from b90.8 to b90.15 reserved for the PLC; a further 8 bits from b91.8 to b91.15 are available for the PLC; these are not stored and are always at zero at drive power-up.

Also 10 word parameters are reserved, specifically from Pr80 to Pr89 with save facility and option for use as 5 double word parameters. For mathematical operations the pico-PLC has 9 constants available, from Pr71 to Pr79 selected from those that are most frequently utilised in standard applications.

When using mathematical instructions (ADD, SUB, MUL, DIV) note that operators are assumed as words with their relative signs. If a double word operation is necessary, parameter b94.0 must be set to 1 before the operation; after the operation the PLC will automatically set the bit to zero. Parameters Pr60...Pr69 are considered as double words so an operation like [ADD 71 72 64] will write the result -1 in the double word Pr64:65 without having to set b94.0=1 before the operation. If Pr80=-1 and Pr81=0, the operation [ADD 80 72 64] will have the result Pr64:65=-1, while the same operation performed with b94.0=1 will assume Pr81 as the high part of the double word Pr80:81 so the result will be Pr64:65=65535. In the first case, therefore, operands other than Pr60...Pr69 will be treated as words, while in the second case they will be treated as double words.

Note that in mathematical operations on double words, operands and results are defined as follows: the operand parameter defines the least significant part while the most significant part is represented by the word with the next serial address (see chapter *Serial addresses and parameter lengths*). Parameters from Pr50 to Pr69 and from Pr80 to Pr89 are successive.



At the completion of each mathematical operation b99.2 is set to 0 if the result is positive, and to 1 if the result is negative; likewise, b99.3=0 if the result is zero and b99.3=1 if it is different from zero. These settings remain valid until the next mathematical operation is performed (the operation is executed only if the stack bit is equal to one). A mathematical operation can be performed, setting the result in one of the constant parameters (Pr71...Pr79) in order to set bits b99.2 and b99.3.

In the case of the DIV operation, if it is executed on a double word the most significant part of the result contains the rest of the division, i.e. if you set b94.0=1 and perform [DIV 79 77 80] the result will be Pr80=4 and Pr81=96.

Note that parameters Pr23, Pr24, Pr25, Pr26, Pr27, Pr29, Pr31 and Pr34 are bytes like Pb42 and Pb94; therefore, these parameters cannot be used for mathematical operations; logical operations must be used to alter their values.

**FIN instruction.** Three instructions are provided for high speed input acquisition: in this case the scan is executed at 512µs (normal scanning is 6.144ms). If used, FIN instructions must be the first PLC instructions. The first FIN instruction copies digital input 1 into bit y of parameter Pb40 (second operand=0) or Pb70 (second operand =1). The second FIN instruction copies digital input 2 into bit y of parameter Pb40 (second operand=0) or Pb70 (second operand=1). The third FIN instruction copies digital input 3 into bit y of parameter Pb40 (second operand=0) or Pb70 (second operand=1). If the second operand is added to value 2, before the input is copied it will be inverted. If a FIN instruction is included at any other position in the program it will have no effect. FIN instructions can be enabled/disabled for each FIN: 1st FIN enabled if b94.5=0; 2nd FIN enabled if b94.6=0; 3rd FIN enabled if b94.7=0.

A FIN instruction in the PLC program after the first three instructions or after any other type of instruction will always be ignored.

There are two timers Pr92 and Pr93 at the disposal of the user. To use the first timer simply load the time in terms of number of samplings (6.144 ms) in parameter Pr92: for example Pr92=100 is equivalent to 614 milliseconds. Pr92 automatically decreases through time, bit b99.0 remains on zero until the timer interval has elapsed; when Pr92=0 then b99.0=1. The same functionality applies to the second timer regarding parameter Pr93 and bit b99.1. Ensure that Pr92 Pr93 b99.0 and b99.1 are refreshed only after the first pico-PLC program scan.

The maximum number of instructions is 64 including the END instruction. Note that mathematical operations occupy the space of two logical operations so when they are used the maximum number of instructions available is decreased accordingly.

The PLC program must always be terminated with an END instruction.

The pico-PLC program can be edited on a PC (see *Programming with Pbrush*) or directly from the keypad. In this latter case, to facilitate procedures, when you need to delete an instruction, select it and then press [M] to display the type of instruction; now keep [M] pressed and simultaneously press [-]; when both keys are released the instruction will be deleted. On the contrary, in order to add an instruction after In06 for example, select the next instruction In07, press [M] to display the type of instruction; now keep [M] pressed and press [+] simultaneously; when both keys are released an FIN instruction will be inserted. In this latter procedure make sure that the instructions in the program are no more than the maximum number or you will lose the last one(s). The pico-PLC program can be edited or altered only when the PLC is in stop status (b99.13=0).

### 4.8.2. Examples and applications

The following examples illustrate possible functionalities obtained by suitable programming of the HPD pico-PLC. The suggested solutions offer the possibility of reducing the components required to build the machine or part of the machine while, in many cases, also cutting the overall cost of the application. Note that the pico-PLC scanning time is 6.144 msec and the maximum number of instructions is 64; moreover, the PLC is designed principally to manage the drive's digital inputs and outputs.

In addition to a concise description of the application, the examples show the settings required for HPD parameters and the pico-PLC program. The program is shown in ladder diagrams and instruction listings.

#### Example 1: two inputs for on/off functions

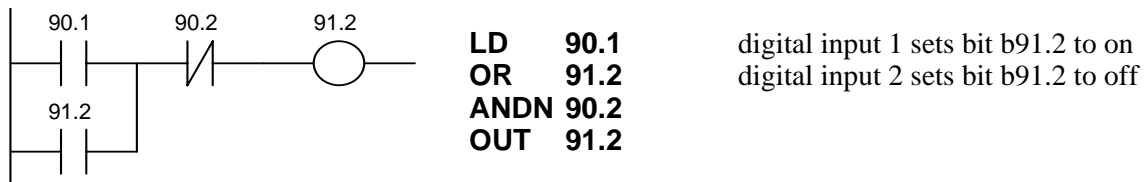

#### Example 2: changing a parameter value with the up/down keys

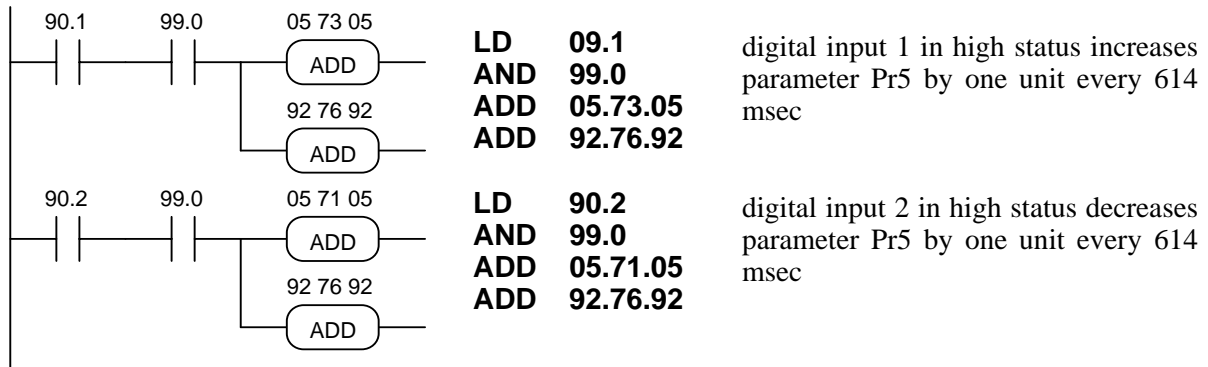

#### Example 3: command on positive front of a digital input

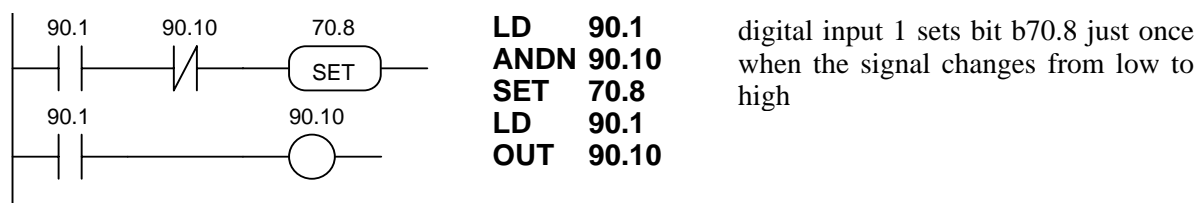

**Example 4: filtered digital input at 60 msec**

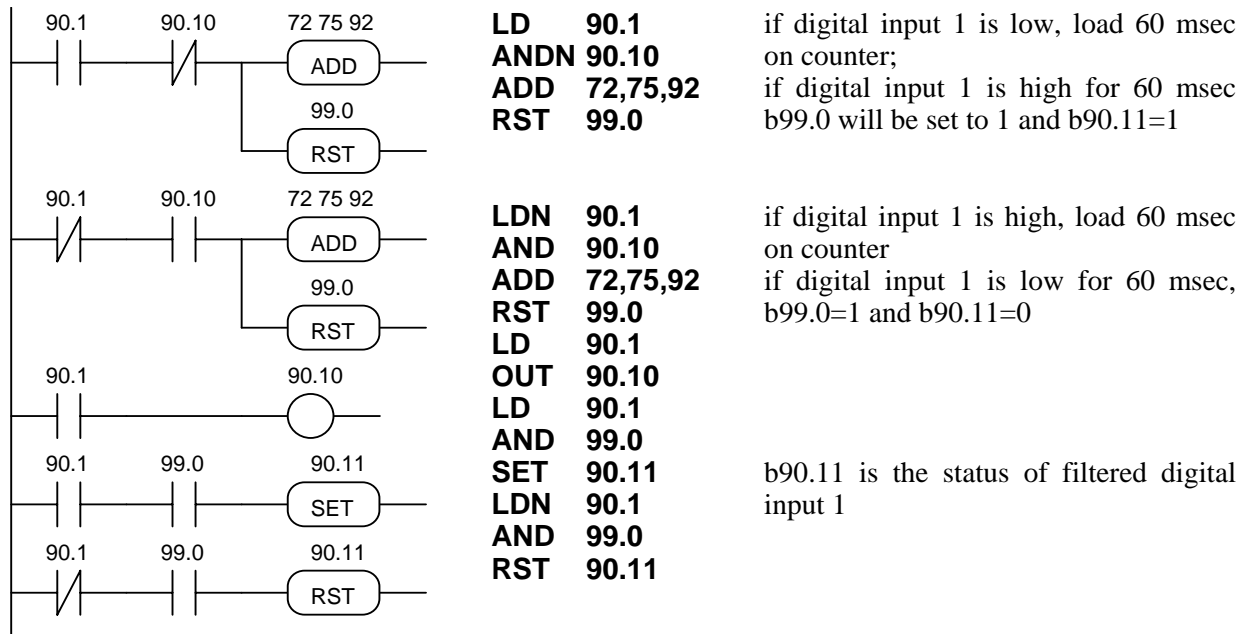

**Example 5: correlation between parameter values**

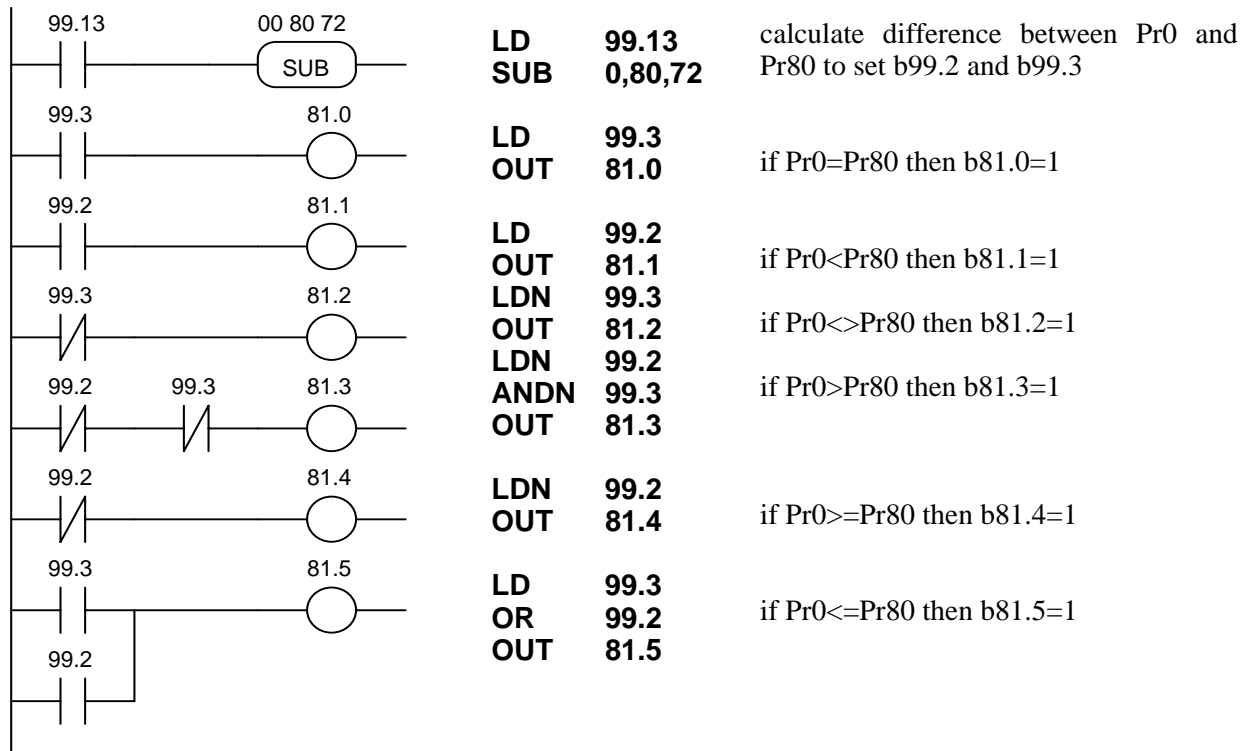

**Example 6: filter (600 msec) for reading the value of a parameter**

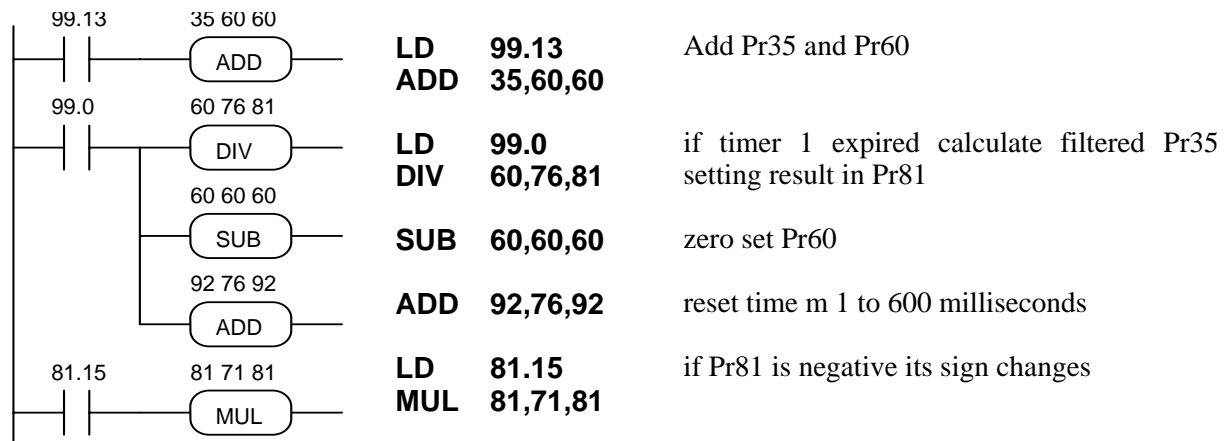

**Example 7: homing**

If you are using an operating mode with spatial control (9, 10 or 11) and you need to align the motor with a zero position defined by a proximity sensor when the system is powered up. You can use two digital inputs, one for the homing command and one to acquire the proximity sensor signal. The commands are pulse type and the homing command is executed once only.

After setting the default values set up the required operating mode (Pr31=xx, b99.11=1, b40.2=1, and any other settings required) and then set the homing speed for the zero proximity sensor in Pr5 and set b40.12=1 to enable Pr5 when b40.2 reaches zero.

Terminal 13 on X3 = pulse command - execute homing.

Terminal 14 on X3 = PNP axis zero proximity sensor.

Bit b91.10 is utilised to signal that the operation is terminated. Note that bits from b91.8 to b91.15 are at the disposal of the PLC and cannot be stored in the memory.

The program is as follows:

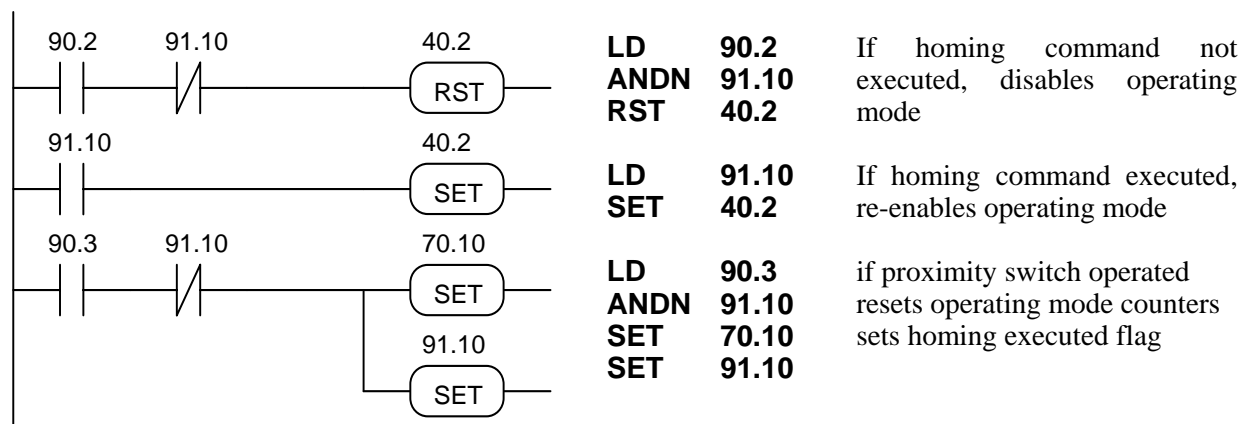

In certain cases a more precise axis zero reference is required; this is achieved using, in addition to the proximity sensor on the machine, also the motor position transducer. In this setup the proximity sensor signal is correlated with the first zero on the motor position transducer.

The following example provides this functionality using operating mode (9) (trapezoidal profile).

After setting default values, set up operating mode 9 (Pr31=9, b99.11=1, b40.2=0, b40.12=1, and any other settings required) and then enter the zero proximity sensor homing speed in Pr5.

Terminal 13 on X3 = homing pulse command.

Terminal 14 on X3 = PNP type axis zero proximity sensor.

Terminal 11 on X2 = digital output. Switches to 1 when the homing phase is terminated.

The following bits are utilised b91.8, b91.9, b91.11.

The program is as follows:

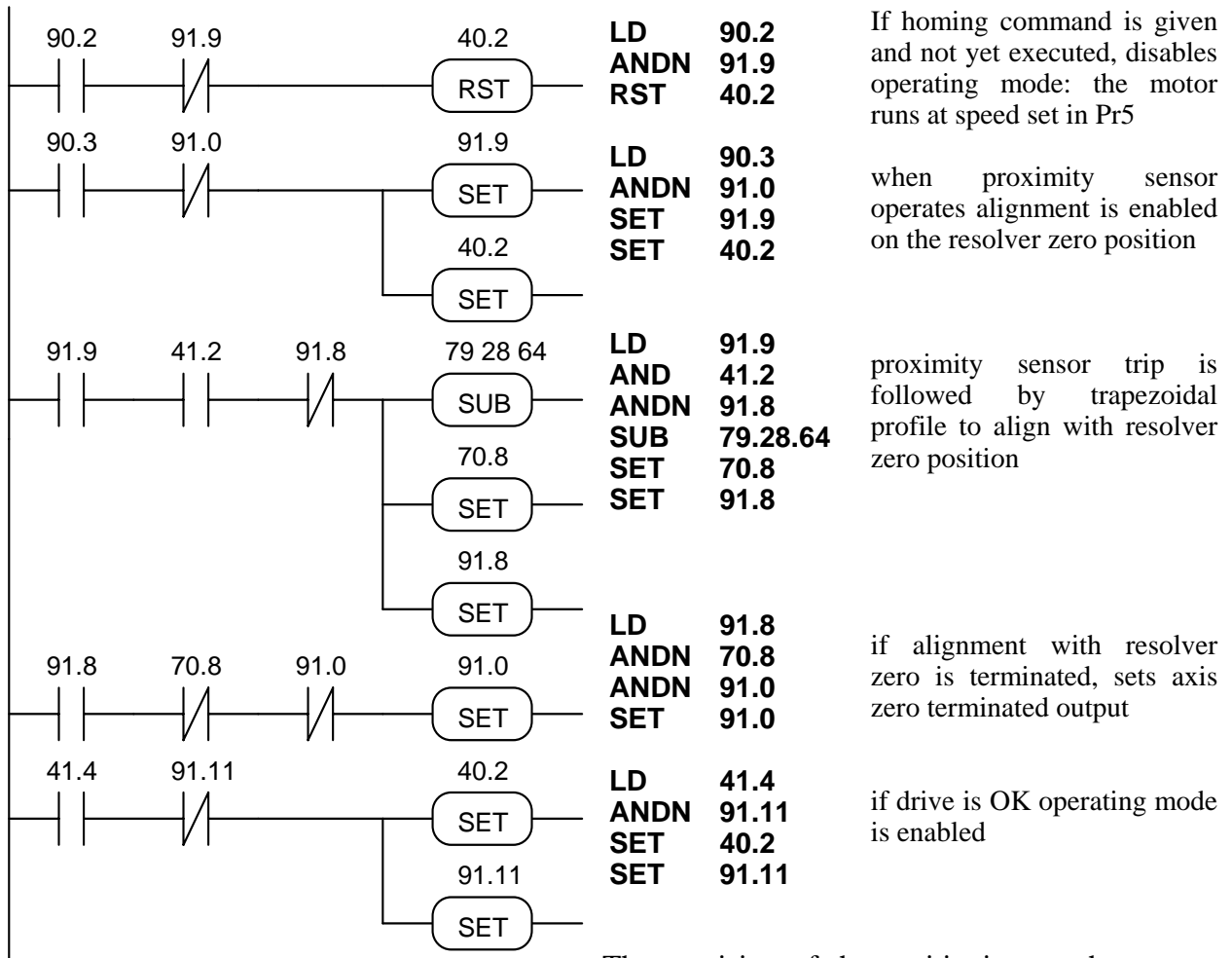

The precision of the positioning on the zero resolver depends on the stability of the motor in the moment in which the trapezoidal profile is calculated for final alignment. You must therefore make sure that the motor shaft has stopped before this calculation. In the example above, the halted motor test is done with bit b41.2. In this case, the imprecision is due to the fact that this bit has a precision of ±1 rpm. Should greater precision be required, in place of the test b41.2 set a sufficient delay to ensure that the motor shaft has stopped.

***Example 8: execution of modulus in digital locking***

(FILE: E001.HPD)

To obtain the following functionality: with reference to the figure assume you have a conveyor transporting product and a blade roller driven by the HPD drive. At start up on an external command the blade roller is aligned with a zero reference (proximity sensor). On receipt of the next pulse command, which is generated by a product detection sensor, the blade roller drive locks onto the conveyor master so that the product is always cut at precisely the same length; when the cut is terminated the blade roller reassumes the starting position awaiting the next cutting command.

In this case the program permits the homing procedure (see chapter 1) and then, on receipt of the command from the product sensor, it assumes digital locked mode and covers a space equal to the value of Pr87:86; when it reaches this distance the drive unlocks and ramps down to the standby position defined by parameter Pr89:88 = modulus. Note that one motor shaft revolution corresponds to 4096 steps so the modulus value to set is equal to the number of steps required by the motor shaft to execute a full revolution of the blade roller. The value of Pr87:86 must be less than the value of the modulus (=Pr89:88).

The master encoder mounted to the conveyor shaft provides the drive with a position reference during the digital locking phase.

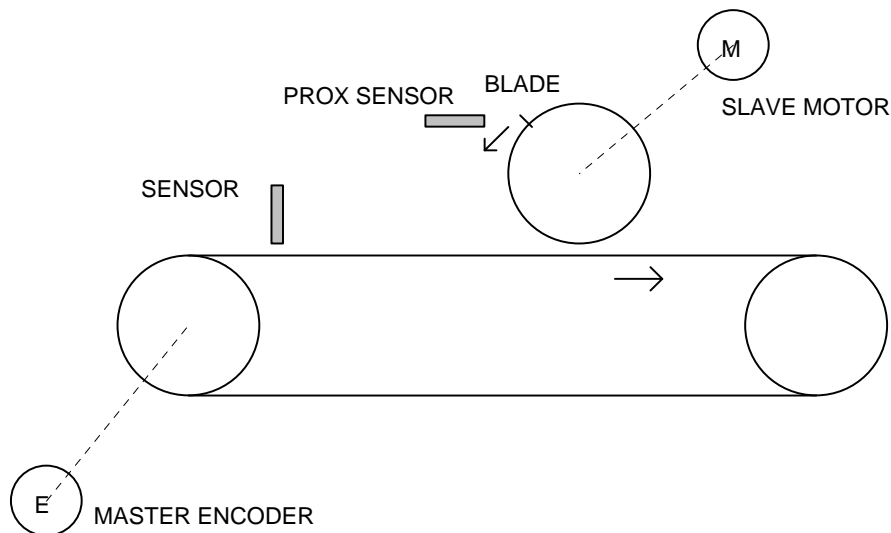

When you have set the default values set the following parameters: Pr5=10 (homing speed), Pr31=10, b99.11=1, b40.2=1, b40.12=1, Pr52=0, b70.3=1, Pr87:86=modulus - ramp, Pr89:88=modulus in which the ramp is expressed in steps, i.e. it is the space that the axis must cover during ramp down. Pay attention when programming Pr89:88 and Pr87:86 because these parameters are utilised as double word format by the PLC but they must be set up as two pairs of single whole words from the keypad. For example, if the modulus is 40960 steps, Pr89 must be set to 0 and Pr88 must be set to 24576.

Terminal 13 on X3 = homing pulse command

Terminal 14 on X3 = NPN type axis zero proximity sensor

Terminal 12 on X3 = pulse command - digital locking engage sensor.

Terminal 12 on X2 = exit - high during modulus execution; if a digital lock command is transmitted during execution of the modulus it will be ignored.

The delay before digital locking varies by up to 2.048 msec max.

The following auxiliary parameters are utilised: Pr83, Pr84, Pr85, b91.10, b91.12.

It is assumed that parameter Pr34 is not used.

The program is as follows:

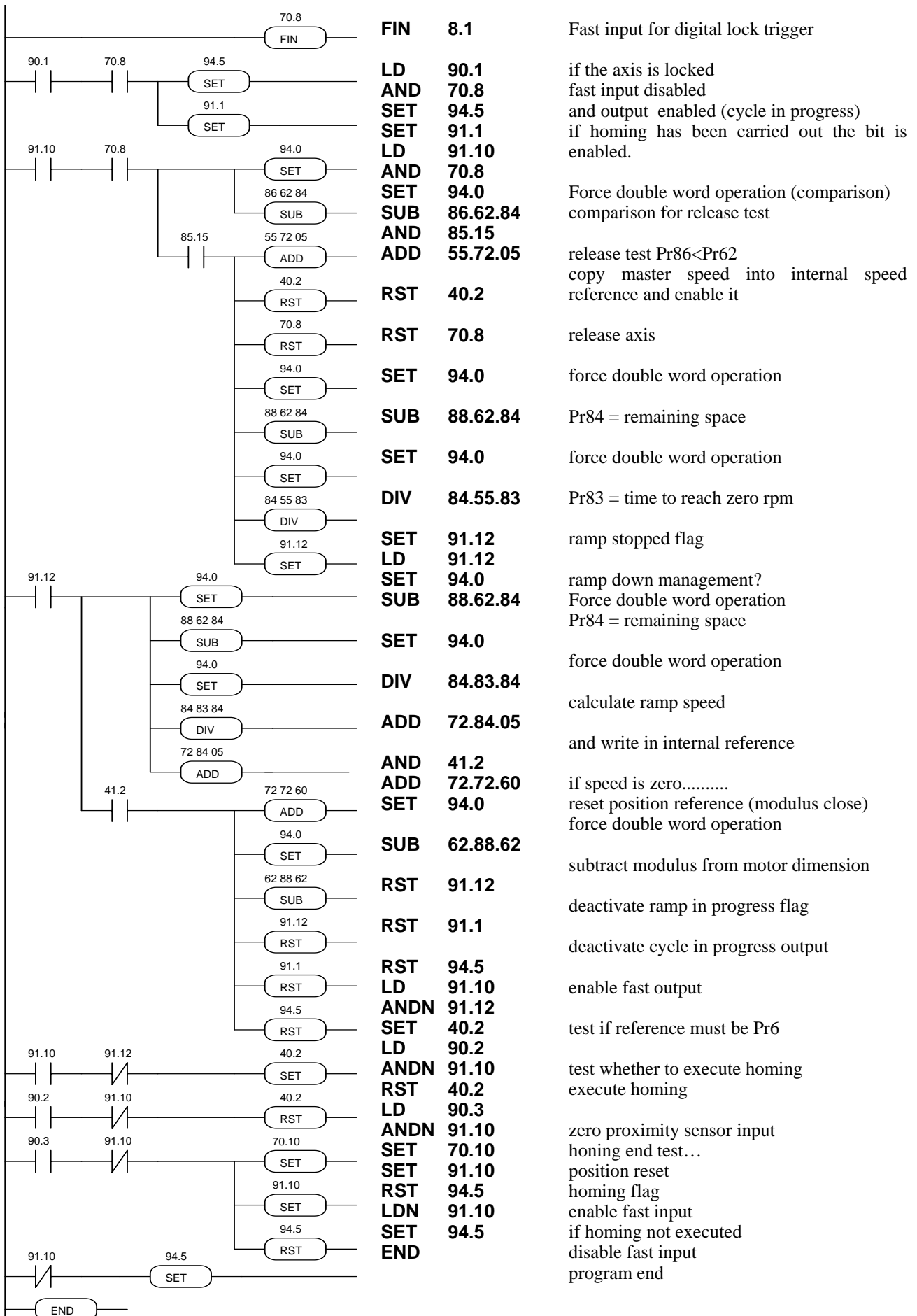



### Example 9: movement with digital locking and return to origin

(FILE: E002.HPD)

To obtain the following functionality: with reference to the figure below assume there is a conveyor transporting product and a carriage running parallel to the conveyor and controlled by an HPD drive. On receipt of an external start command the carriage is aligned on a zero reference position (proximity sensor). With a second pulse command, provided by a product detection sensor, the drive locks on to the conveyor in order to perform an operation on the product at a precisely defined position; when this operation is terminated the carriage returns to its starting position.

In this case the program makes it possible to execute homing (see chapter 1) after which, on receipt of the manual command from the sensor, the carriage locks on and covers a distance equal to the value of Pr87:86; when this distance is reached the drive unlocks and stops according to the ramp programmed in parameter Pr83. The motor now automatically returns to the origin position executing a trapezoidal profile with the ramps set in Pr80 and the speed in Pr81. Note that one motor revolution corresponds to 4096 steps so the value to set in Pr87:86 should correspond to the number of steps of the motor shaft needed for the carriage to execute the required translation.

The master encoder on the conveyor shaft provides the drive with the necessary position reference during digital locking.

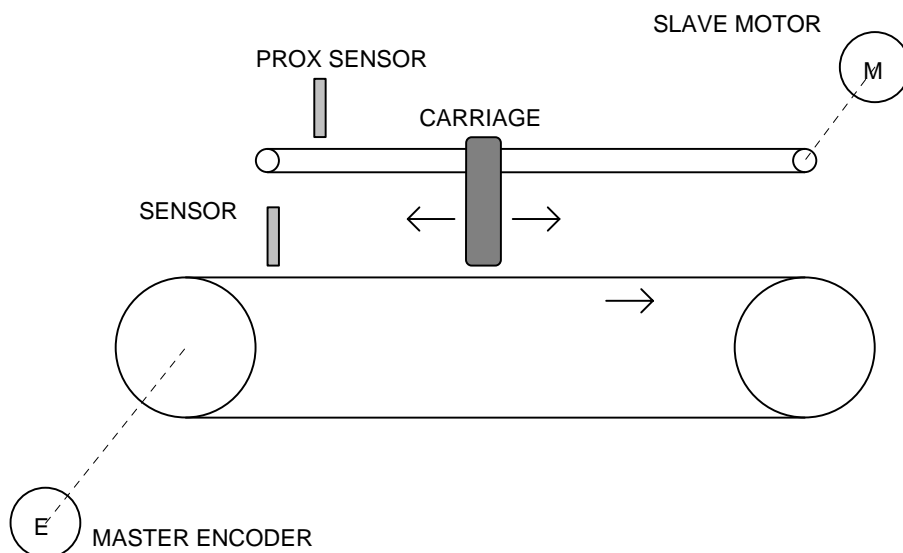

After having set the default values, program the following parameters:

Pr5=10 (homing speed), Pr31=10, b99.11=1, b40.2=1, b40.12=1, Pr80=trapezoidal profile ramp, Pr81=trapezoidal profile speed, Pr82=copy of P.51 in digital locking, Pr83=digital locking release deceleration ramp, Pr84=copy of Pr53 in digital locking, Pr87:86=release dimension in steps

terminal 13 on X3 = pulse command for homing execution

terminal 14 on X3 = axis zero position PNP proximity sensor

terminal 12 on X3 = digital locking sensor pulse command

terminal 12 on X2 = output; high during cycle execution; digital locking commands received during cycle execution will be disregarded.

The digital locking delay interval can be up to 6.144 msec.

The following auxiliary bits are utilised: b91.10, b91.12.

Program (see on next page) :

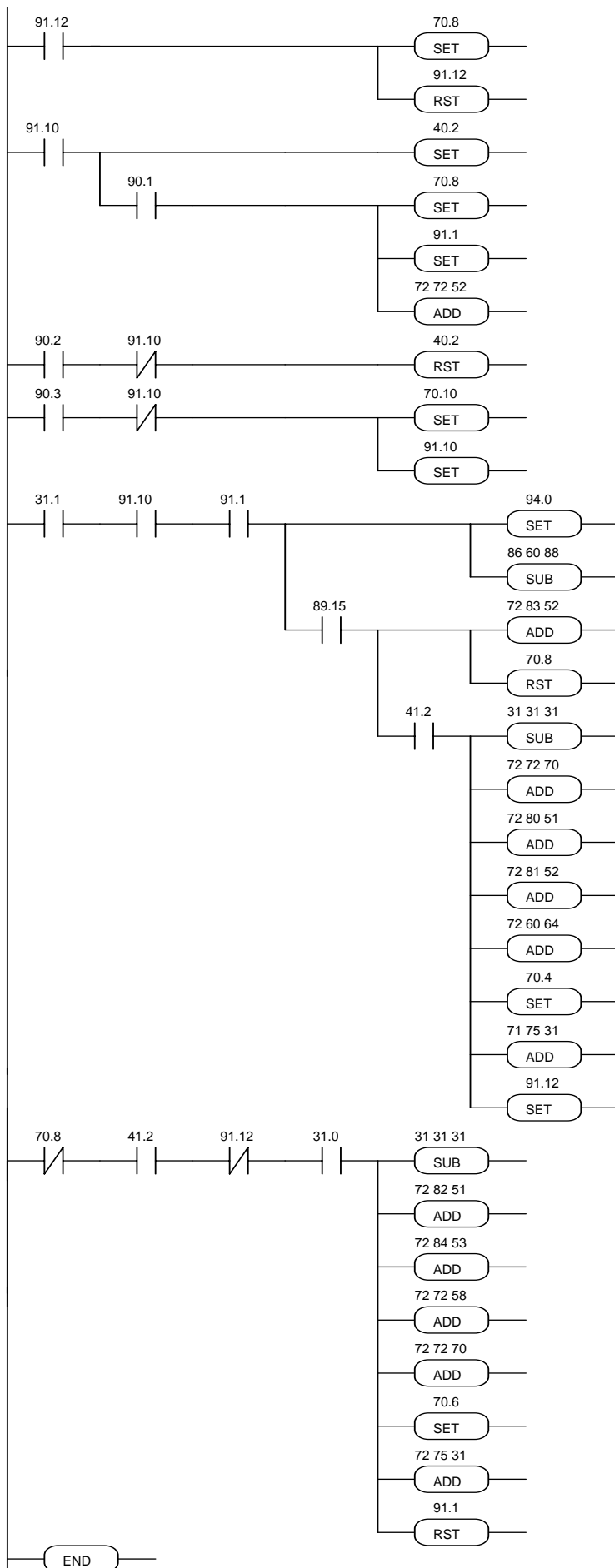

<b>LD</b>	<b>91.12</b>	
<b>SET</b>	<b>70.8</b>	return start management
<b>RST</b>	<b>91.12</b>	with trapezoidal profile
<b>LD</b>	<b>91.10</b>	
<b>SET</b>	<b>40.2</b>	if homing exec. ref=pr6
<b>AND</b>	<b>90.1</b>	locking start request
<b>SET</b>	<b>70.8</b>	locking
<b>SET</b>	<b>91.1</b>	cycle output on
<b>ADD</b>	<b>72.72.52</b>	no ramp pr52=0
<b>LD</b>	<b>90.2</b>	
<b>ANDN</b>	<b>91.10</b>	homing request
<b>RST</b>	<b>40.2</b>	
<b>LD</b>	<b>90.3</b>	
<b>ANDN</b>	<b>91.10</b>	stand by for proximity
<b>SET</b>	<b>70.10</b>	reset dimensions
<b>SET</b>	<b>91.10</b>	homing exec. flag
<b>LD</b>	<b>31.1</b>	
<b>AND</b>	<b>91.10</b>	if OPM = 10
<b>AND</b>	<b>91.1</b>	if homing is done
<b>SET</b>	<b>94.0</b>	and locked
<b>SUB</b>	<b>86.60.88</b>	forces double word
<b>SUB</b>	<b>86.60.88</b>	release dimension
<b>AND</b>	<b>89.15</b>	reached ?
<b>ADD</b>	<b>72.83.52</b>	
<b>RST</b>	<b>70.8</b>	set release ramp
<b>AND</b>	<b>41.2</b>	and release axis
<b>SUB</b>	<b>31.31.31</b>	if speed is zero
<b>ADD</b>	<b>72.72.70</b>	disable OPM
		reset all b70
<b>ADD</b>	<b>72.80.51</b>	trapezoidal profile ramp
<b>ADD</b>	<b>72.81.52</b>	trapezoidal profile speed
<b>ADD</b>	<b>72.60.64</b>	copy position in
<b>SET</b>	<b>70.4</b>	incremental dimension
<b>ADD</b>	<b>71.75.31</b>	and reverse for return
		set OPM 9
		preset start
<b>SET</b>	<b>91.12</b>	profile at next scan
<b>LDN</b>	<b>70.8</b>	if no profile in exec.
<b>AND</b>	<b>41.2</b>	Motor stopped
<b>ANDN</b>	<b>91.12</b>	no profile preset
<b>AND</b>	<b>31.0</b>	and OPM is 9
<b>SUB</b>	<b>31.31.31</b>	disable OPM
<b>ADD</b>	<b>72.82.51</b>	reset ratio
<b>ADD</b>	<b>72.84.53</b>	reset ratio
<b>ADD</b>	<b>72.72.58</b>	zero set slip
<b>ADD</b>	<b>72.72.70</b>	zero set all bits
<b>SET</b>	<b>70.6</b>	enable feed forward
<b>ADD</b>	<b>72.75.31</b>	set OPM 10
<b>RST</b>	<b>91.1</b>	zero set current cycle
<b>END</b>		program end

### Example 10: Inter-Drive Communication

IDC (Inter Drive Communication) refers to a specific configuration of the serial port of the HPD drive that makes it possible to interchange parameters between two or more units.

With IDC enabled (Pr26=10) if bit b99.5 is set to 1 the HPD activates a broadcast command by sending the value of Pr81 to the address of Pr80. HPDs that receive broadcast commands with Pr26=10 automatically set b99.5 to 1 causing automatic transmission of Pr81 to the address of Pr80 in broadcast mode. Using this potential, it is extremely simple to connect two HPD drives in a loop via the serial ports, and a short program on the internal PLC will suffice to start transmission at power-on and restore it in the event of communication errors. The following example describes the PLC program required to copy Pr81 from the two drives in parameters Pr80.

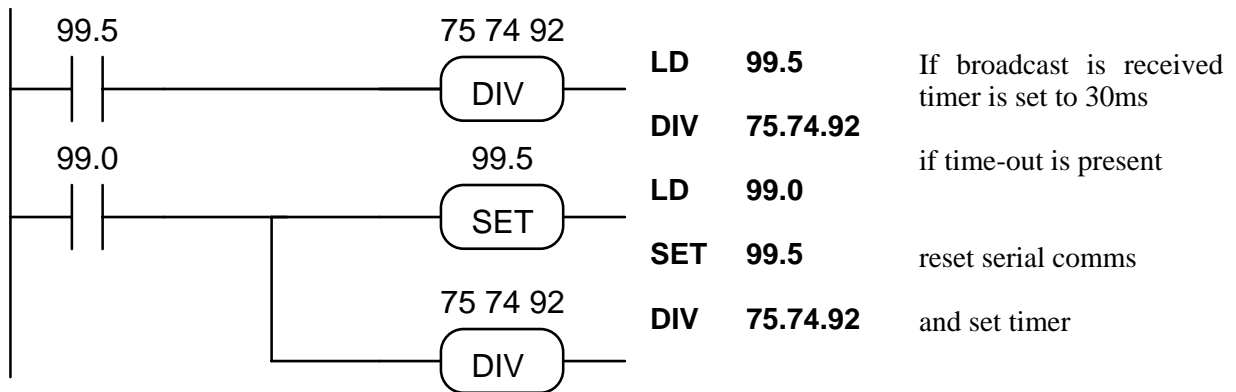
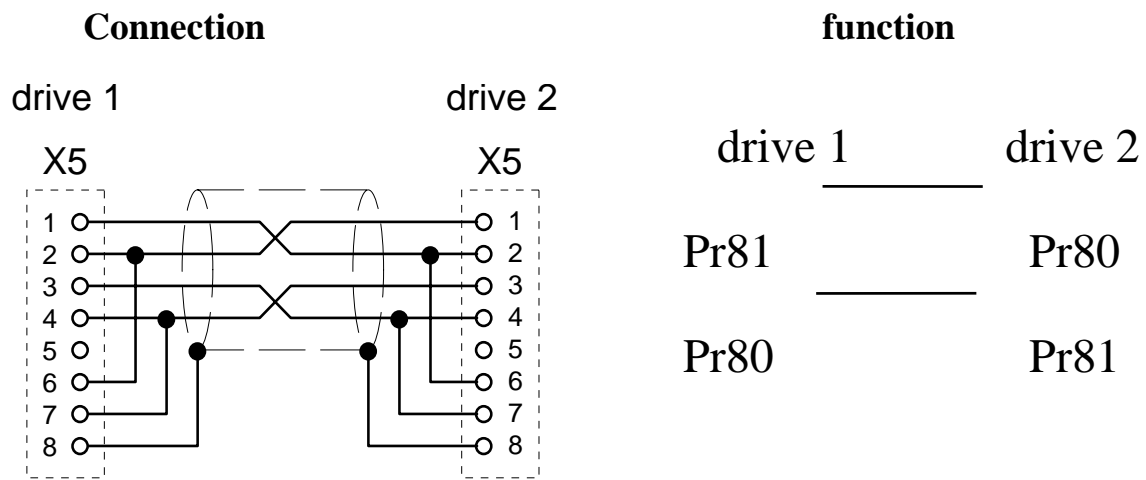

These PLC instructions must be entered on only one of the drives; both drives must have parameter Pr26=10 to enable the IDC function.

### Example 11: 5 positioning with teach-in

(FILE: E003.HPD)

To obtain the following functionality: with reference to the figure, assume you need to acquire 5 different machine positions and then execute them automatically.

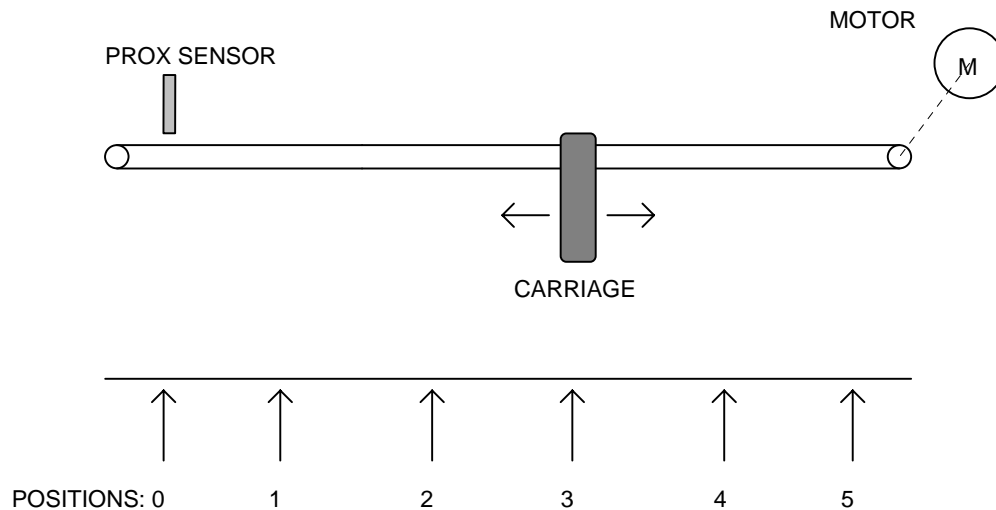

This can be achieved using a smart keypad module (see appendix L, SBC1 program) connected on the serial communications line with the drive and with the internal PLC. When the machine is powered up the drive will stand by to receive the homing exec command and the keypad will show the message “axis zero (F4)”. By pressing [F4] or sending a pulse command to digital input 2 of the drive, the motor shaft will turn at the speed established by parameter Pr5 until the intervention of the proximity sensor at digital input 3. The keypad display will now present the message “automatic dimension 1”; digital inputs 4, 5 and 6 select the position to be reached, while a pulse supplied to digital input 1 provides a trapezoidal profile to reach the selected position. The following table shows the relationship between parameters Pr80...Pr89 and the encoding of the 3 digital inputs; for example, input 4 on one selects position 1 and the distance in steps between the zero axis point and position 1 is set in Pr81:80, bearing in mind that one revolution of the motor shaft is equivalent to 4096 steps.

Input 6	Input 5	Input 4	position	dimension
0	0	1	1	Pr81:80
0	1	0	2	Pr83:82
0	1	1	3	Pr85:84
1	0	0	4	Pr87:86
1	0	1	5	Pr89:88
other combinations			0	axis zero

If you want to set the dimension from the keypad, press [F3] and the display will show the message “dimension xx yyyy“ where xx defines the dimension in question and yyyy determines the relative value. The [+] and [-] keys are used to modify the value yyyy while [F3] changes the value xx.

If you wish to acquire the required position by moving the carriage, press [F1]: the display will show the message “manual dimension xx “; [F1] selects the xx dimension to be programmed while [+] and [-] are used to move the carriage. The [+] key provides the motor start/stop in the positive direction, while [-] provides the start/stop in a negative direction; the translation speed in this case must be set in parameter Pr4. Once the required position has been reached, press [C] to confirm the dimension. Press [F2] to set automatic mode.

To store the parameters you have programmed press [S].

After having set the default values, set the following parameters on the HPD drive:

Pr4=10 manual translation speed

Pr5=5 homing speed

Pr31=9, b99.11=1, b40.2=1, b40.12=1

Pr81:80=dimension 1

Pr83:82=dimension 2

Pr85:84=dimension 3

Pr87:86=dimension 4

Pr89:88=dimension 5

terminal 12 on X3 = pulse command - execute positioning

terminal 13 on X3 = pulse command - execute homing

terminal 14 on X3 = PNP zero axis proximity sensor

terminal 15 on X3 = select position

terminal 16 on X3 = select position

terminal 17 on X3 = select position

terminal 11 on X2 = output: high during homing

terminal 12 on X2 = output, high during positioning

terminal 13 on X2 = output, high during manual translation

The following auxiliary bits are utilised: b91.10, b91.11.

The program is as follows:

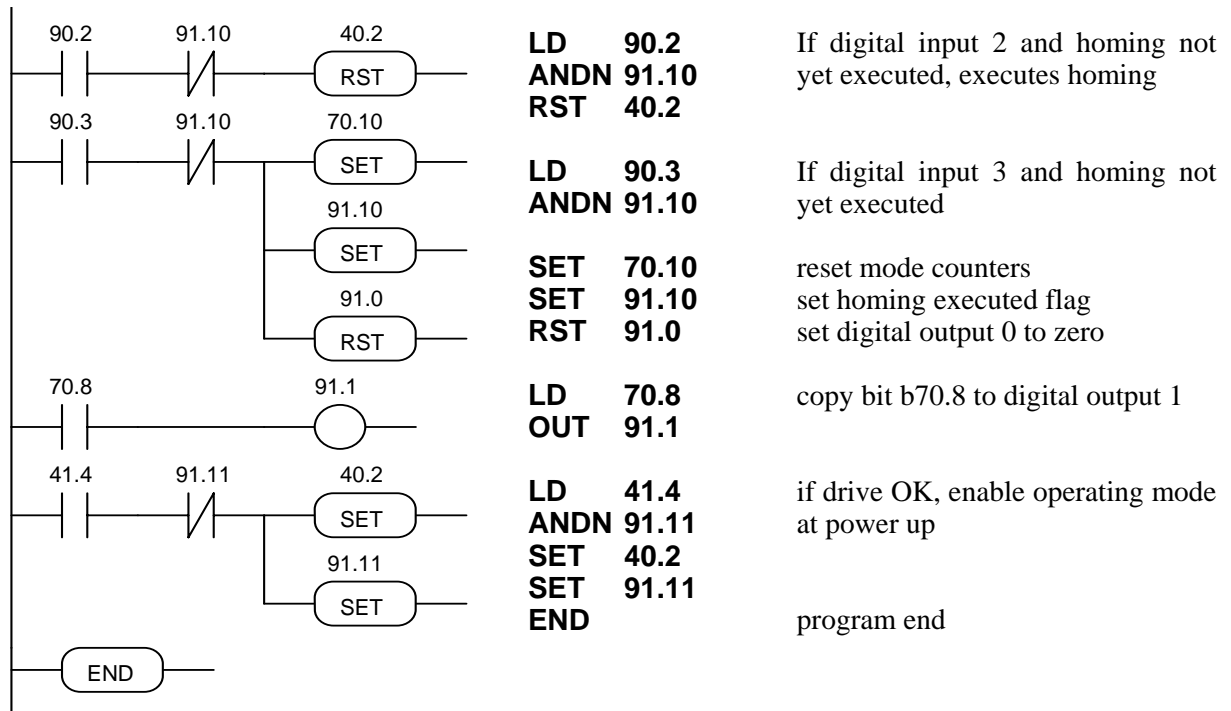

Inputs and outputs can be read and written directly via the serial communications line so there is no need to use the pico-PLC if you have an intelligent unit connected to the drive via the serial line. For more information regarding the serial line, refer to the HPD user manual.

## Example 12: 5 positioning

(FILE: E004.HPD)

Referring to the figure below, assume you need to move the carriage to 5 different positions selected by means of three digital signals.

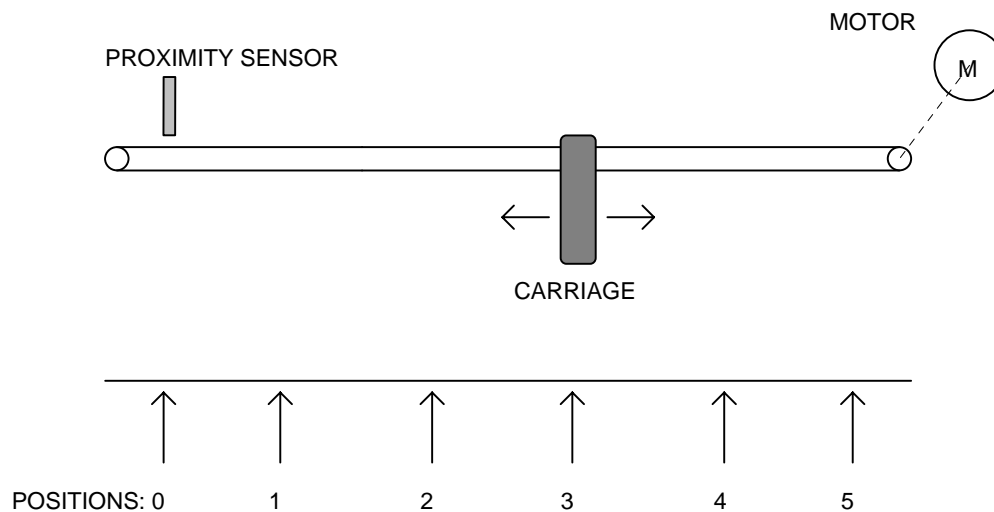

The positions are set in parameters Pr80...Pr89 in resolver steps taking the position of the proximity sensor as the zero value. When the machine is powered up the drive remains in standby mode awaiting the homing execution command: when a pulse command is supplied to digital input 2 of the HPD drive the motor shaft will turn at the speed set in parameter Pr5 until the proximity switch provides a signal at digital input 3. At this point digital inputs 4, 5 and 6 select the position to be reached, while a pulse on digital input 1 makes it possible to perform positioning on a trapezoidal profile. The following table shows the relationship between parameters Pr80...Pr89 and the encoding on the 3 digital inputs; for example, only input 4 on one selects position 1 and the distance in steps between the zero axis point and position 1 is set in steps, bearing in mind that one revolution of the motor shaft corresponds to 4096 steps.

Input 6	Input 5	Input 4	Position	Dimension
0	0	1	1	Pr81:80
0	1	0	2	Pr83:82
0	1	1	3	Pr85:84
1	0	0	4	Pr87:86
1	0	1	5	Pr89:88
other combinations			0	axis zero

After having set the default values, set the following parameters on the HPD unit:

Pr5=5 homing speed

Pr31=9, b99.11=1, b40.2=1, b40.12=1

Pr81:80= dimension 1

Pr83:82= dimension 2

Pr85:84= dimension 3

Pr87:86= dimension 4

Pr89:88= dimension 5

terminal 12 on X3 = execute positioning - pulse command  
 terminal 13 on X3 = execute homing - pulse command  
 terminal 14 on X3 = PNP axis zero proximity sensor  
 terminal 15 on X3 = position selection  
 terminal 16 on X3 = position selection  
 terminal 17 on X3 = position selection  
 terminal 12 on X2 = output, high during positioning  
 The following auxiliary bits are utilised: b91.10, b91.11.  
 Program:

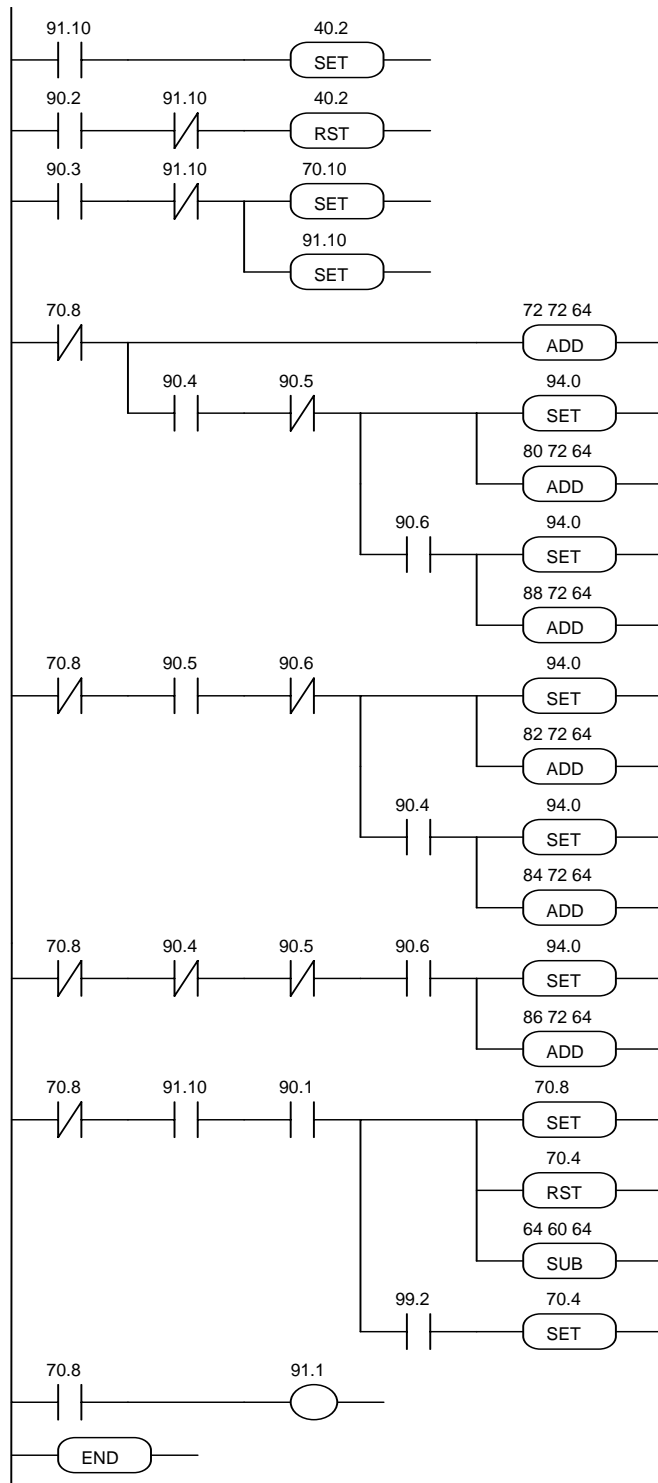

<b>LD 91.10</b>	If homing already
<b>SET 40.2</b>	executed enable
	operating mode
<b>LD 90.2</b>	
<b>ANDN 91.10</b>	If digital input 2
<b>SET 40.2</b>	execute homing if not
<b>LD 90.3</b>	yet done
<b>ANDN 91.10</b>	
<b>SET 70.10</b>	if digital input 3 and
<b>SET 91.10</b>	homing not executed:
	reset counters
<b>LDN 70.8</b>	homing exec flag
<b>ADD 72.72.64</b>	digital output 0 at zero
<b>AND 90.4</b>	
<b>ANDN 90.5</b>	if profile terminated,
<b>SET 94.0</b>	select dimension
<b>ADD 80.72.64</b>	according to the three
<b>AND 90.6</b>	digital inputs
<b>SET 94.0</b>	
<b>ADD 88.72.64</b>	
<b>LDN 70.8</b>	
<b>AND 90.5</b>	
<b>ANDN 90.6</b>	
<b>SET 94.0</b>	
<b>ADD 82.72.64</b>	
<b>AND 90.4</b>	
<b>SET 94.0</b>	
<b>ADD 84.72.64</b>	
<b>LDN 70.8</b>	
<b>ANDN 90.4</b>	
<b>ANDN 90.5</b>	
<b>AND 90.6</b>	
<b>SET 94.0</b>	
<b>ADD 86.72.64</b>	
<b>LDN 70.8</b>	if profile terminated
<b>AND 91.10</b>	and input 1=1 execute
<b>AND 90.1</b>	profile resetting
<b>SET 70.8</b>	direction bit and
<b>RST 70.4</b>	calculating distance
<b>SUB 64.60.64</b>	with respect to current
<b>AND 99.2</b>	motor position
<b>SET 70.4</b>	if negative sign set
	b70.4=1
<b>LD 70.8</b>	
<b>OUT 91.1</b>	digital output 2
<b>END</b>	indicates profile on
	program end



### Example 13: reading 4-digit controller

(FILE: E005.HPD)

You wish to change the value of parameter Pr83 using a 4-digit controller. Four digital inputs and four digital outputs are used for this:

block 12 of X2 = output to select the first digit (least significant) of the controller

block 13 of X2 = output to select the second digit of the controller

block 14 of X2 = output to select the third digit of the controller

block 15 of X2 = output to select the fourth digit of the controller

blocks 12...15 of X3 = inputs to read digits in BCD (block 12 is the least significant bit; the connection diagram is shown on the following page).

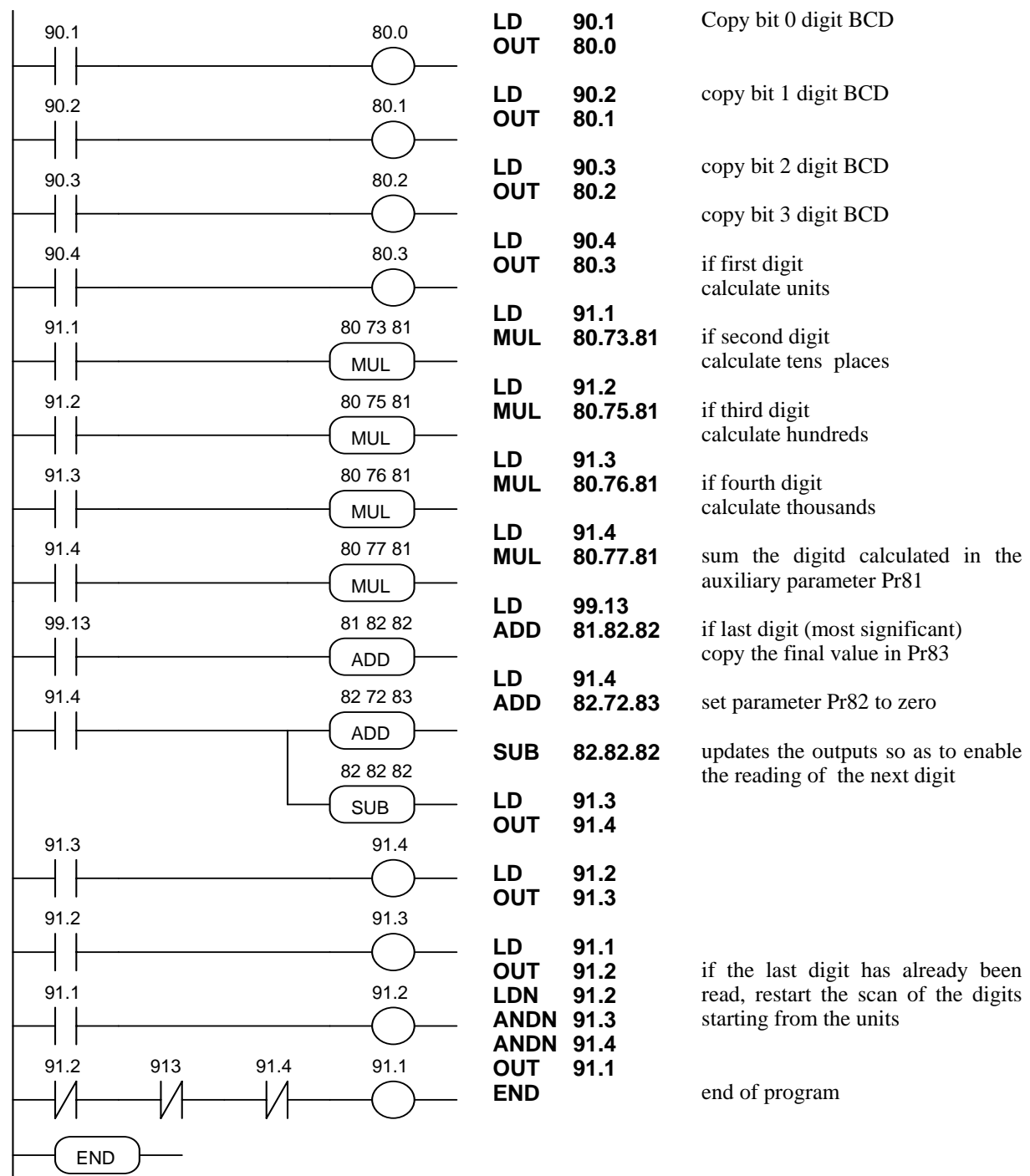



## 4.9. Programming with Pbrush



The **HPD serial kit** is supplied to enable communication between a PC and the drive. The kit includes an RS-422/RS-232 converter, relative 230V~ power supply and serial connection cable. The enclosed communication software (supplied free of charge) designated **Pbrush** has the following HW/SW requirements: 486 microprocessor or higher, *Windows\* 3.1* or more recent version, mouse and serial port for drive connections. The main features of Pbrush are:

- serial connection of up to 32 drives
- reading and setting of basic parameters and drive commands
- reading and setting of commands and parameters of operating modes
- functional block diagrams
- pico-PLC program displayed as ladder diagrams
- display of pico-PLC program status during operation
- I/O status
- file storage of parameterisation including pico-PLC program
- uploading of parameterisation including pico-PLC program from a file that can be selected from among those previously stored
- speed regulator and position controller simulation

PC - HPD connection layout (HPD serial kit):

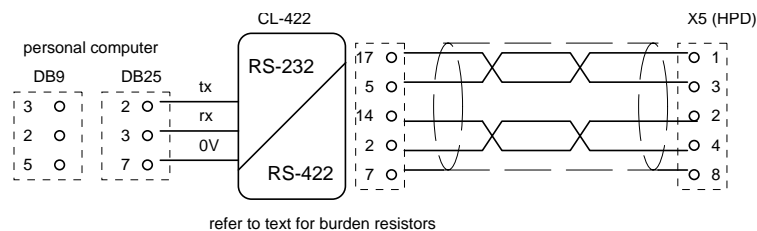

To create line load (burden) resistances, jumper pins 2 and 6, and pins 4 and 7 on connector X5 of the last drive on the serial line.

If the PC is a battery powered laptop (i.e. not connected to ground) use the following connection layout:

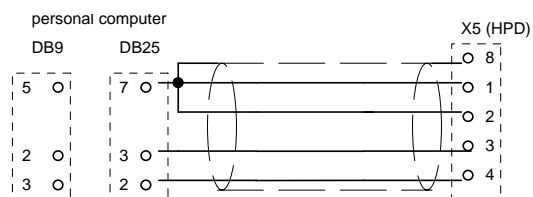

To install Pbrush open *WINDOWS\**, insert the diskette in drive A, select the *File* menu in Program Manager and then the *Run*.option. Now run Setup.exe on [A:\] by typing the following string on the *Command line*: *A:\setup.exe* or by selecting the file with the *Browse...*button. The following installation procedure automatically creates a new icon for Pbrush. Once the program is installed, launch it by double clicking the relative icon (or select the icon and then press ENTER).

Set the following parameters on the drive: Pr26=6, Pr27=0, b40.14=1, b42.3=1.

- *Windows* and the Windows logo are registered trade marks or trade marks owned by Microsoft Corporation in the United States of America and/or other countries.

## 5. SERIAL INTERFACE

The drive communication protocol is “master-slave” half-duplex type on an asynchronous RS-485/RS-422 line. The drives assume control of the line only following interrogation by the master.

Up to 32 drives can be connected on the same serial line, allocating each a different serial address in parameter Pr27. It is also possible to set transmission speed in parameter Pr26 as specified in the table:

Pr26 (decimal base)	b/s	time-out (ms)
0	600	512
1	1200	256
2	2400	128
3	4800	64
4	9600 (*)	32
5	9600	32
6	19200	16
7	38400	12
8	57600	8
9	125000	4
10	57600 (**)	8

(\*) The version with code Pr26=4 differs from Pr26=5 because of the 25 ms response delay. This version was developed to interface with PLCs that require this characteristic.

(\*\*) The version with code Pr26=10 was developed to allow data communication between two HPD drives.

Refer to the heading *Serial line connection* for connection diagrams.

### 5.1. Communication protocol

The right hand column in the table shows the time-out value in milliseconds for each communication speed; this is the time, starting from the beginning of each message (STX) within which the transmission of the message must terminate. Therefore, if the message is interrupted, after the time-out the drive will ignore the information already received and stand by to receive a new message.

Messages are made up of several consecutive data in the following format:

- 1 start bit
- 8 data bits following one byte between square brackets
- 1 parity bit (even)
- 1 stop bit

The message structure is:

[STX] [CMD+ADDR] [LUN] [PAR] [D0] ... [Dn] [CHK]

where:

[STX] = \$7E transmission start indicator. If a field other than STX should assume the value \$7E in the message, this field is followed by a (\$00) to ensure that it cannot be interpreted as an [STX].

[CMD+ADDR] = command and address of peripheral device, always different to zero. This datum is composed as follows: the first 5 bits (from 0 to 4) define the drive address (from 0 to 31); the remaining 3 bits (from 5 to 7) define the type of message, as described in the following table:

CMD	bit 7	bit 6	bit 5	message type
1	0	0	1	drive response
2	0	1	0	read PLC instruction
3	0	1	1	write PLC instruction
4	1	0	0	read parameter
5	1	0	1	write parameter
6	1	1	0	bit change
7	1	1	1	broadcast parameters to all drives

[LUN] = total number of bytes transmitted (parameter or PLC instruction); can assume values from 1 to 4. This value must not hold zero characters (\$00) after values that coincide with the initial transmission character (\$7E).

[PAR] = parameter or PLC instruction read/write address

[D0] ... [Dn] = datum transmitted.

[CHK] = 256 modulus sum of all fields except [STX] (checksum).

### Message types

[CMD1] = drive response to data request, format:

[STX] [001+ADDR] [LUN] [PAR] [D0] ... [Dn] [CHK]

or confirm message in response to data entry or update, format:

[STX] [001+ADDR]

where ADDR identifies the answering drive.

[CMD2] = read message of PLC area instruction; format:

[STX] [010+ADDR] [LUN] [PAR] [CHK]

[CMD3] = write message of PLC area instruction; format:

[STX] [011+ADDR] [LUN] [PAR] [D0] ... [Dn] [CHK]

[CMD4] = parameter read message; format:

[STX] [100+ADDR] [LUN] [PAR] [CHK]

[CMD5] = parameter write message; format:

[STX] [101+ADDR] [LUN] [PAR] [D0] ... [Dn] [CHK]

[CMD6] = byte parameter bit change message; format:

[STX] [110+ADDR] [LUN] [PAR] [D0] [D1] [CHK]

In this case (LUN=2) two bytes are transmitted for the data: the first byte is the mask containing 0 in the positions of the bits to change and 1 in the other positions; the second byte contains 1 in bit positions to be set to 1 and 0 in the other positions. The address PAR corresponds to the parameter (byte) in which one or more bits is to be modified. If the parameter is a word and the bit to be modified is among the first 8 (b0...b7): PAR = parameter address; otherwise if the bit to modify is one of the upper 8 (b8...b15): PAR = parameter address + 1.

[CMD7] = parameter write broadcast message to all drives connected to the serial line; format:

[STX] [11100000] [LUN] [PAR] [D0] ... [Dn] [CHK]

The address of peripheral device (ADDR) must be zero.

#### Notes:

- Parameters shown on the display with decimals must be treated as integer values, e.g. 978.5 will be read, and written, as 9785.
- All values preceded by the symbol \$ are hexadecimal numbers.
- The value in square brackets is the basic unit (byte) of the message.
- To be considered valid all messages must be terminated within a clearly defined time interval (time-out) which is a function of speed, and they must have correct parity and checksum.
- The drive responds to data requests or transmission only if the message is received correctly; if the message contains an error, no answer will be transmitted. The only exception is message type 7, with which a datum is transmitted with a single message addressed to all drives connected to the serial line.

## Serial line initialisation and management

Drive serial communication can be enabled or disabled by means of bit b40.14.

The drive is factory set with b40.14=0, i.e. serial line disabled (default).

If you want to use the serial line first set the baud-rate in Pr.26; now set the serial address in Pr.27; finally, enable serial communication by setting b40.14=1 and initialise using b42.3. At this point you must save the configuration using command b99.15.

For parameter addresses and lengths refer to the relative table.

In the case of PLC instructions, each one occupies 2 or 4 bytes, the format of which is described below.

Instruction		code	length (bytes)
LD	Pa.y	0	2
LDN	Pa.y	1	2
OUT	Pa.y	2	2
OUTN	Pa.y	3	2
AND	Pa.y	4	2
ANDN	Pa.y	5	2
OR	Pa.y	6	2
ORN	Pa.y	7	2
ADD	Pa, Pb, Pc	8	4
SUB	Pa, Pb, Pc	9	4
MUL	Pa, Pb, Pc	10	4
DIV	Pa, Pb, Pc	11	4
SET	Pa.y	12	2
RES	Pa.y	13	2
FIN	Pb40.y/Pb70.y	14	2
END		15	2

The memory area available for PLC instructions is 128 bytes, with addresses from 0h to 7Fh.

As the minimum length for each instruction is 2 bytes, the PLC program can hold a maximum of 64 instructions.

The first four bits of the first byte in each instruction (b0..b3) contain the instruction **code**.

For the first 8 instructions in the table (LD...ORN) and the SET and RES instructions, the remaining 4 bits of the first byte (b4..b7) contain the value **y**, while the second byte contains the value **Pa**.

For instructions ADD, SUB, MUL and DIV, the second byte contains the value **Pa**, the third **Pb**, and the fourth **Pc**.

The second byte is not utilised for the END instruction.

For the FIN instruction the fifth bit (b4) of the first byte selects the parameter: b4=0 refers to Pr.40, b4=1 refers to Pr.70; the sixth bit (b5) of the first byte is used for negative logic if required: b5=0 the bit is copied; b5=1 the bit is inverted and then copied. The second byte of the FIN instruction contains the value of **y**.

If FIN instructions are used they must be the first of the program and there must be no more than 3 so they will occupy addresses from 0h to 5h. If a FIN instruction is included from address 6h forward or, anyway, after any other instruction, it will be ignored (NOP).

The instructions must be one after the other starting from address 0h, without any free bytes.

There is just one program and it terminates with the END instruction.

## Serial line application examples

For a better understanding of how to implement the serial line communication protocol, we have provided a few examples for each type of message.

The values are entered simply by way of example.

### Case 1: reading a 1 byte parameter

Assume you want to read the value of parameter Pr.31 (operating mode), and that the value of this parameter is 9; assume the drive serial address is 0. The message to transmit is:

```
[$7E][$80][$01][$54][$D5]
```

The drive answers with the message:

```
[$7E][$20][$01][$54][$09][$7E][$00]
```

### Case 2: reading a 2 byte parameter

Assume you wish to read the reference speed (Pr.7) and that the relative value is 2000; assume also that the drive serial address is 1. The message to transmit is:

```
[$7E][$81][$02][$42][$C5]
```

The drive answers with:

```
[$7E][$21][$02][$42][$D0][$07][$3C]
```

### Case 3: writing a 1 byte parameter

Assume you want to select operating mode 1 (Pr.31); assume also that the drive serial address is 3. The message to transmit is:

```
[$7E][$A3][$01][$54][$01][$F9]
```

The drive answers with:

```
[$7E][$23]
```

### Case 4: writing a 2 byte parameter

Assume you intend to set rated current at 25.3% (Pr.33); assume also that the drive serial address is 3. The message to transmit is:

```
[$7E][$A3][$02][$C6][$FD][$00][$68]
```

The drive answers with:

```
[$7E][$23]
```

### Case 5: setting a bit to 1

Assume you want to enter the command to save the PLC program (b99.14=1); assume also that the drive serial address is 0. The message to transmit is:

```
[$7E][$C0][$02][$93][$BF][$40][$54]
```

The drive answers with:

```
[$7E][$20]
```



**Case 6: setting a bit to 0**

Assume you want to disable the drive by software (b40.9=0); assume that drive serial address is 0. The message to transmit is:

[7E][C0][02][5D][FD][00][1C]

The drive answers with:

[7E][20]

**Case 7: writing a PLC instruction**

Assume you want to set the first PLC instruction as: LD 90.4; assume the drive serial address is 0. The message to transmit is:

[7E][60][02][00][40][5A][FC]

The drive answers with:

[7E][20]

**Case 8: reading the first PLC instructions**

Assume you want to read the first instructions of the PLC default program; assume the serial address of the drive is 0. The message to transmit is:

[7E][40][04][00][44]

The drive answers with the message:

[7E][20][04][00][10][5A][A7][5A][8F]

which corresponds to the acquisition of the following instructions: LD 90.1, ORN 90.10.

## 5.2. Serial addresses and parameter lengths

Parameter	Address	Length	Meaning
Pr0	038h	2	motor speed in rpm
Pr1	034h	2	analogue reference
Pr2	03Ah	2	full scale 1
Pr3	03Ch	2	full scale 2
Pr4	036h	2	frequency full scale
Pr5	03Eh	2	internal reference
Pr6	040h	2	reserved reference
Pr7	042h	2	chosen reference
Pr8	0AEh	2	positive acceleration in seconds
Pr9	0B0h	2	positive deceleration in seconds
Pr10	0B2h	2	negative acceleration in seconds
Pr11	0B4h	2	negative deceleration in seconds
Pr12	0B6h	2	limit switch deceleration
Pr13	0B8h	2	overspeed threshold
Pr14	044h	2	top speed limit
Pr15	046h	2	lower speed limit
Pr16	048h	2	integral gain
Pr17	0BAh	2	damping factor
Pr18	0BCh	2	filter time constant
Pr19	0BEh	2	user current limit
Pr20	04Ah	2	DC bus voltage
Pr21	04Ch	2	reserved torque limit
Pr22	04Eh	2	auxiliary reference
Pr23	051h	1	current alarm code
Pr24	052h	1	previous alarm code
Pr25	053h	1	software version code
Pr26	05Eh	1	baud rate
Pr27	05Fh	1	serial address
Pr28	0C0h	2	shaft position (0..4095)
Pr29	061h	1	motor poles
Pr30	0C2h	2	resolver offset
Pr31	054h	1	operating mode
Pr32	0C4h	2	rated motor speed
Pr33	0C6h	2	rated current
Pr34	055h	1	scale factor for tacho generator
Pr35	0C8h	2	filtered torque request
Pr36	058h	2	i <sup>2</sup> t accumulation
Pr37	05Ah	2	thermal image for braking
Pr38	0CAh	2	auxiliary analogue output
Pr39	0CCh	2	K for phase advance
Pb40	05Ch	2	flags used by main block

Pb41	056h	2	flags used by main block
Pb42	060h	1	flags used by main block
Pr50	064h	2	
Pr51	066h	2	
Pr52	068h	2	
Pr53	06Ah	2	
Pr54	06Ch	2	
Pr55	06Eh	2	
Pr56	070h	2	
Pr57	072h	2	
Pr58	074h	2	
Pr59	076h	2	
Pr60	078h	2	
Pr61	07Ah	2	
Pr62	07Ch	2	
Pr63	07Eh	2	
Pr64	080h	2	
Pr65	082h	2	
Pr66	084h	2	
Pr67	086h	2	
Pr68	088h	2	
Pr69	08Ah	2	
Pb70	062h	2	flags used by operating mode
Pr80	0CEh	2	
Pr81	0D0h	2	
Pr82	0D2h	2	
Pr83	0D4h	2	
Pr84	0D6h	2	
Pr85	0D8h	2	
Pr86	0DAh	2	
Pr87	0DCh	2	
Pr88	0DEh	2	
Pr89	0E0h	2	
Pb90	0E2h	2	inputs
Pb91	08Ch	2	outputs
Pr92	08Eh	2	timer 1
Pr93	090h	2	timer 2
Pb94	032h	1	flags used by PLC
Pb99	092h	2	flags used for PLC and commands

PLC area length: 128 bytes, addresses 00h to 7Fh.

**6. Appendix A: HPD drive mechanical dimensions**

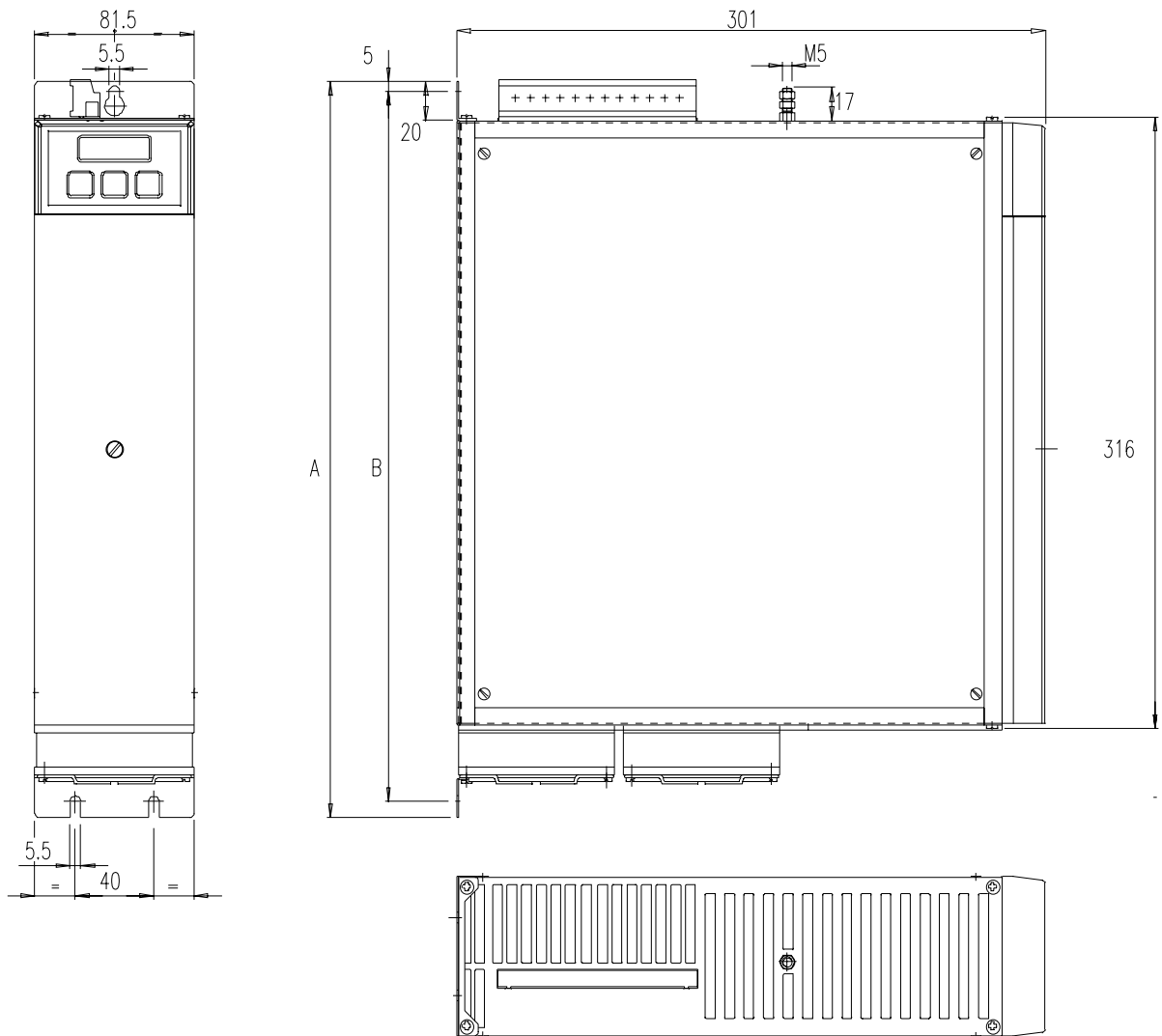

Dimensions can be changed at discretion of the manufacturer.

drive type	A	B	weight kg
HPD2N	348	335	5.1
HPD5N, HPD8N, HPD16N, HPD20N,HPD24N	377	364	5.5

## 7. Appendix B: hardware characteristics



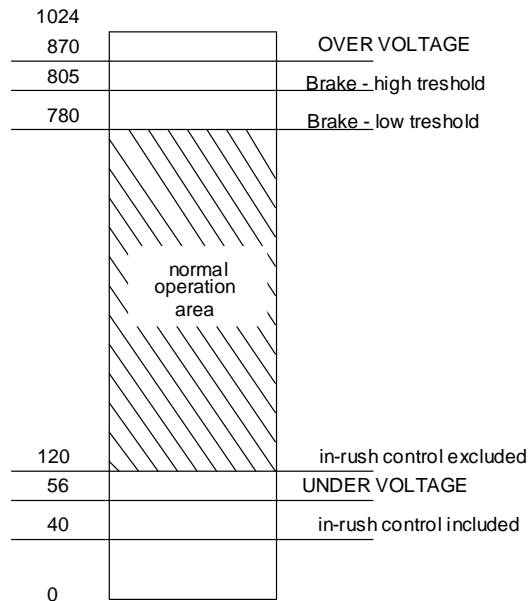

digital input		
input impedance	7k	ohm
VH	15..30	V
VL	0..3	V
digital output		
type	PNP open collector	
VH using internal supply	20..26	V
IO for single output	100	mA
IT current for all outputs using internal supply	200	mA
IT current for all outputs using ext. supply +24 VIN	500	mA
VSW max. voltage between out 6 A and out 6 B	110	V~
ISW max. current trough out 6 A and out 6 B	600	mA
analogue reference		
type	differential	
impedance	20	Kohm
range	$\pm 10$	V
CMMR	> 60	dB
resolution	15	bits
aux. analogue input		
type	differential	
impedance	250	Kohm
range	$\pm 10$	V
CMMR	> 40	dB
resolution	10	bits
analogue output		
type	single ended	
IO max.	1.5	mA
range	$\pm 10$	V
resolution	8	bits

**8. Appendix C: DC bus voltage thresholds**

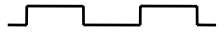

**The modification of the above thresholds makes potentially dangerous to wire together the DC BUSES of HPD"N" drives with HPD drives.**

**9. Appendix D: Standard settings**

Reference	Positive
Shaft moving	(motor shaft view): 
Torque monitor	Positive
R/D Counter	UP
Encoder out	A  B 
tacho signal	positive
Iu	$torque \cdot \sin(\vartheta)$
Iv	$torque \cdot \sin\left(\vartheta + \frac{2 \cdot \pi}{3}\right)$
IN AUX positive	Pr22 positive
Pr38 positive	OUT AUX. Positive
Encoder In. A  B 	Counter Up

## 10. Appendix E: Software timers

<b>Time slot</b>	<b>Task running</b>
256 $\mu$ s	Torque vector generation
512 $\mu$ s	Speed loop
	Fast operating mode manager
	Torque limit evaluation
	Speed reference manager
	Brake resistor manager
	Fast input
2.048 ms	Slow operating mode
6.144 ms	Motor thermal image algorithm
	Digital input
	PLC instruction scan
	Digital output
49.152 ms	Speed windows manager

## 11. Appendix F: pico-PLC default program

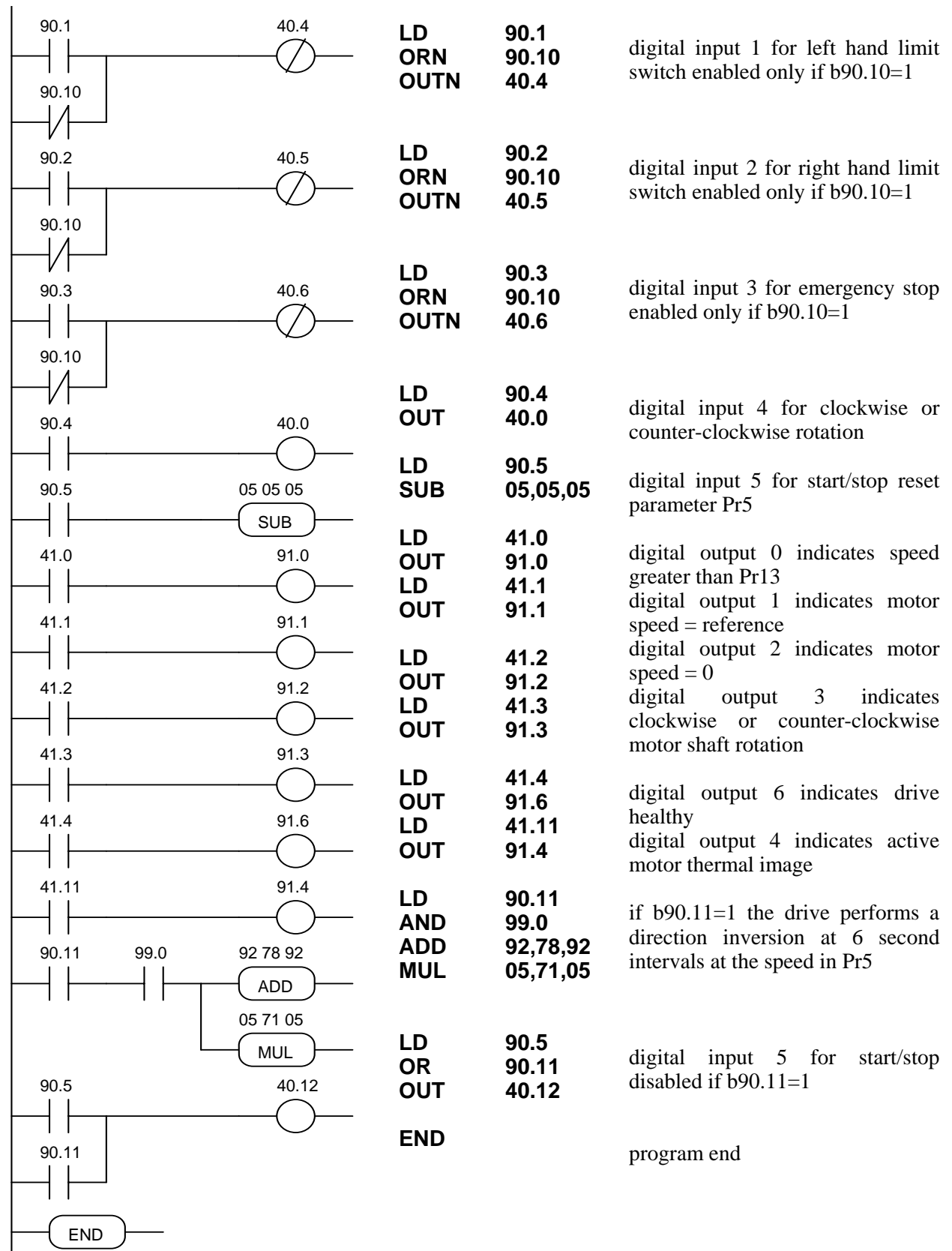



## 12. Appendix G: flash information

- USE b99.15 TO SAVE PARAMETERS
- USE b99.14 TO SAVE PLC PROGRAM
- TO CHANGE PLC INSTRUCTIONS b99.13 MUST BE AT 0
- WHEN CHANGING OPERATING MODE USE b99.11 TO LOAD DEFAULT PARAMETERS (b40.2=0)
- WARNING, BEFORE CHANGING Pr31 MAKE SURE b40.2=0
- SPEED REFERENCE IS LIMITED TO THE VALUE IN Pr32
- IN TORQUE CONTROL Pr2 AND Pr3 MUST BE SET TO 1000
- TO USE THE ACTIVE OPERATING MODE b40.2 MUST BE SET TO 1
- TO USE Pr32 TO CHANGE FEEDBACK RESOLUTION ON THE FLY, DISABLE TORQUE COMPENSATION (b42.6=0)
- IF YOU CANNOT UPDATE READ/WRITE PARAMETERS FROM THE KEYPAD, MAKE SURE b99.7=0. IF b99.7=0, THE PARAMETERS ARE PROBABLY MANAGED BY THE PLC PROGRAM.

## 13. Appendix H: Alarms

If problems are encountered with the drive or the control system, use the following table to identify the fault and take the recommended corrective action.

**To cancel the error on the drive, first remedy the cause and then set Pb99.10 = 1 (reset).**

**Error Code HPD: 1**      **Over Voltage** on the D.C. Link. Check the three-phase power line (max 460 V).

Check the break circuit and the braking resistor

**Error Code HPD: 2**      **Under Voltage** on the D.C. Link. Check the three-phase power line (minimum voltage: 90 V).

**Error Code HPD: 3**      **Over current.** Check for any mechanical blockage and make sure the motor is the appropriate size for its current use.

Check the motor connections and for any phase-phase or phase-ground short-circuits.

Check the machine speed and the service cycle.

Make sure a line trap isn't connected to the motor!

**Error Code HPD: 4**      **Resolver.** Check the connections of the resolver and the connectors on both sides (drive-motor).

**Error Code HPD: 5**      **Motor Over Temperature**  
Check the connection of the PTC motor on terminals 1 and 2 of X1.

Check the settings of parameters Pr33 (Inom) and Pr19 (Ipicco).

**Error Code HPD: 6**      **Drive Over Temperature.** Check the cooling fans and for any restrictions to air flow.

Check the breaking cycle.

Check the environmental temperature of the electrical control panel where the drive is installed, as well as the external room temperature.

**On start up, the display doesn't read IDLE or RUN or it stays off**      Check the external fuses on the three-phase power supply.  
Make sure that the line traps (if installed) and motor are connected correctly.

Check the voltage on the power supply terminals X4, terminals 1, 2, and 3.

Check the bridge on X4 between terminals 7 and 8.

	Check the keypad connection and make sure it was installed correctly.
<b>The HPD's LED display shows decimal points on all characters</b>	<p>The drive goes in I<sup>2</sup>T mode due to an overload (it required more current that was available).</p> <p>Check:</p> <ul style="list-style-type: none"> <li>- The cables between motor and HPD (there should be no inverted phases). Take special care with motors with terminals rather than the connector: it's easy to make a mistake. Adhere strictly to the wiring diagrams.</li> </ul> <p>Mechanical measurements</p> <p><b>The most likely cause of this is an incorrect connection between the encoder output of the drive (X7) and the encoder input on the axis control.</b></p> <p>Another possibility is an incorrect connection between the terminals of the analogue output of the axes (DRV1 and Gnd) and the analogue reference input of the <b>HPD</b> (X2-terminals 1 and 2 with shielding on terminal 3).  <b>Check the wiring of both the analogue reference signal cable and the reaction signal cable (encoder). If correct, invert the analogue input on the HPD (X2, terminals 1 and 2).</b></p> <p>See below if the motor now rotates in the wrong direction.</p>
<b>Motor runaway occurs when the drive is enabled.</b>	
<b>The motor turns slowly when the drive is enabled.</b>	<p>The drive isn't under the control of the axis controller.</p> <p>Check the cable connecting the encoder output (X7) and the axis controller.</p> <p>Check the analogue reference cable connecting the drive (X2 – terminals 1, 2, and 3) and the axis controller.</p> <p>Make sure the analogue output of the axis controller is putting out a current.</p>
<b>The motor doesn't move and has no torque.</b>	<p>Make sure the display shows <b>RUN</b> when the drive is enabled.</p> <p>If not, check the connection between X3-terminals 11 and 19. Recheck the programming of the HPD and the wiring.</p> <p>Check the I/O signals for the axis controller.</p>
<b>The motor turns in the wrong direction</b>	Invert the encoder signals <b>A &amp; /A</b> and the analogue reference inputs on the <b>HPD</b> (X2 – terminals 1 and 2).

## 14. Appendix I:options

For the HPD converters, the following options are also available:

### Operator Interfaces

Field bus interfaces	profibus-dp	EC-4
	Device Net	EC-4
	CanBus	EC-4
	ModBus	EC-4
	Sercos	EC-4
Absolut encoder interfaces	SSI	EC-4
	Hiperface	EC-4
I/O expansions		EC-4 – I/O BOX
High performance axis controls		EC-4

### Preparation for the expansion boards.

If you wish to use expansion boards such as the EC-4 or the EC-5, the converter must be ordered with the code HPD x NE0, where x is the nominal current.

## 15. Appendix L: EC4

### 15.1. Product description

EC-4 is an expansion board for HPD-series converters which significantly improves performance. Basically, the code EC-4 identifies a hardware product. To use the EC-4, you need to install the software required.

### 15.2. Main characteristics

The main characteristics of the EC-4 are shown in the table below:

<i>Format</i>	<i>Europe 1 measurements 100 x 160 mm</i>	
<i>Degree of protection</i>	<i>IP 00</i>	
<i>Field bus</i>	<i>Profibus-DP</i> <i>CAN bus</i> <i>RS-422</i>	<i>Up to 12 Mb</i> <i>DeviceNet</i> <i>SBCCan</i> <i>ModBus for operator panel</i>
<i>Feedback used for the position loop</i>	<i>Resolver (directly via HPD)</i> <i>Incremental encoder 5 V RS - 422</i> <i>SSI absolute encoder</i> <i>Hyperface absolute encoder</i>	
<i>Power supply for auxiliary encoders</i>	<i>programmable voltage 5V - 8V - 12V - 15V</i> <i>250mA protected.</i>	
<i>Digital inputs</i>	<i>8 PNP-type</i>	
<i>Digital outputs</i>	<i>8 PNP-type 100mA with short-circuit protection</i>	

### **ATTENTION !**

**EC-4 is only for drive**

### **HPD x N EO**

**EC-4 can only be installed on drives with a certain software version or higher**

**15.3. EC-4 block diagram**

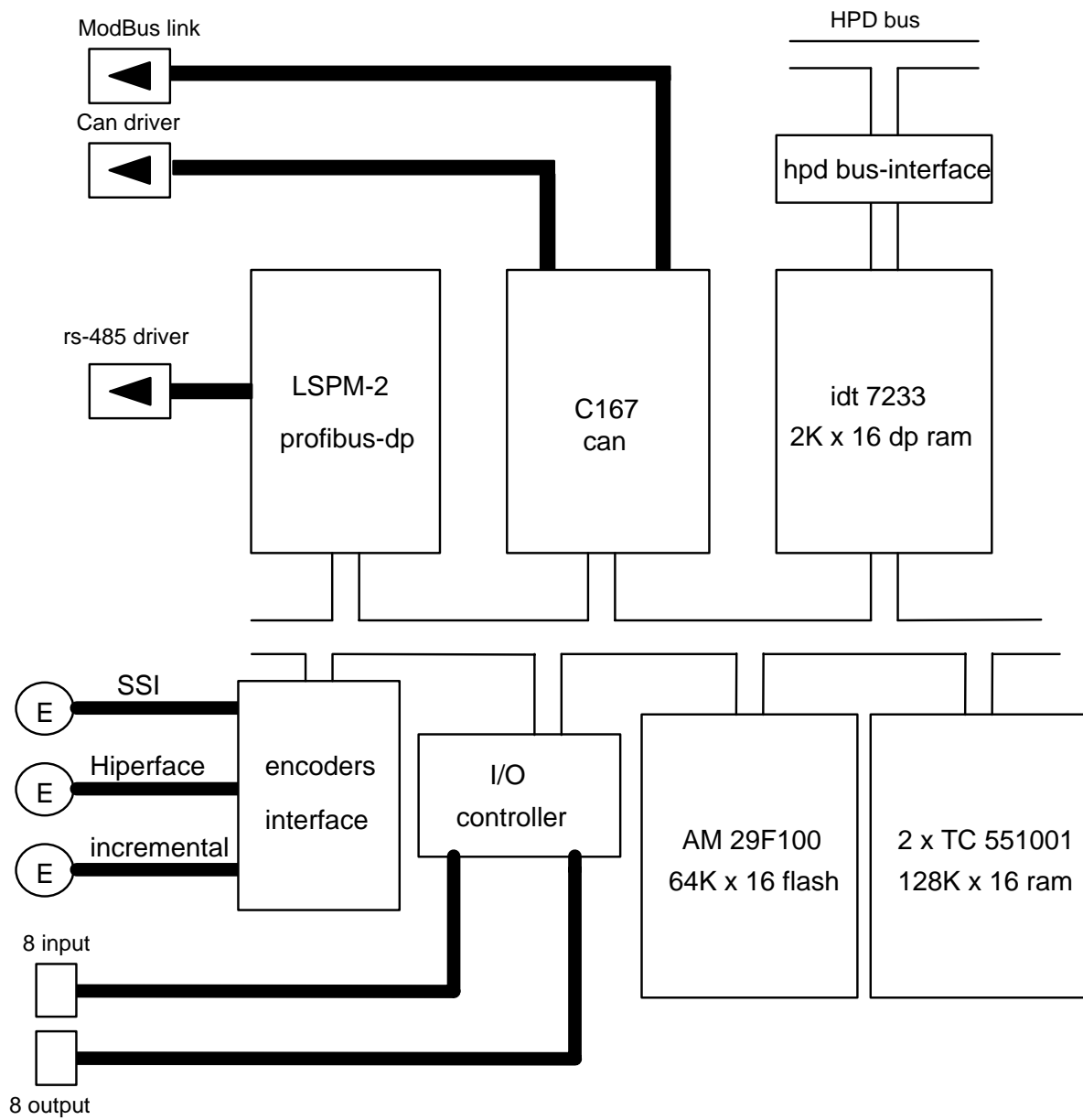

**15.4. Product and connectors identification**

The SW field on the label of the EC-4 panel must be filled in using indelible ink by the person who installed the software

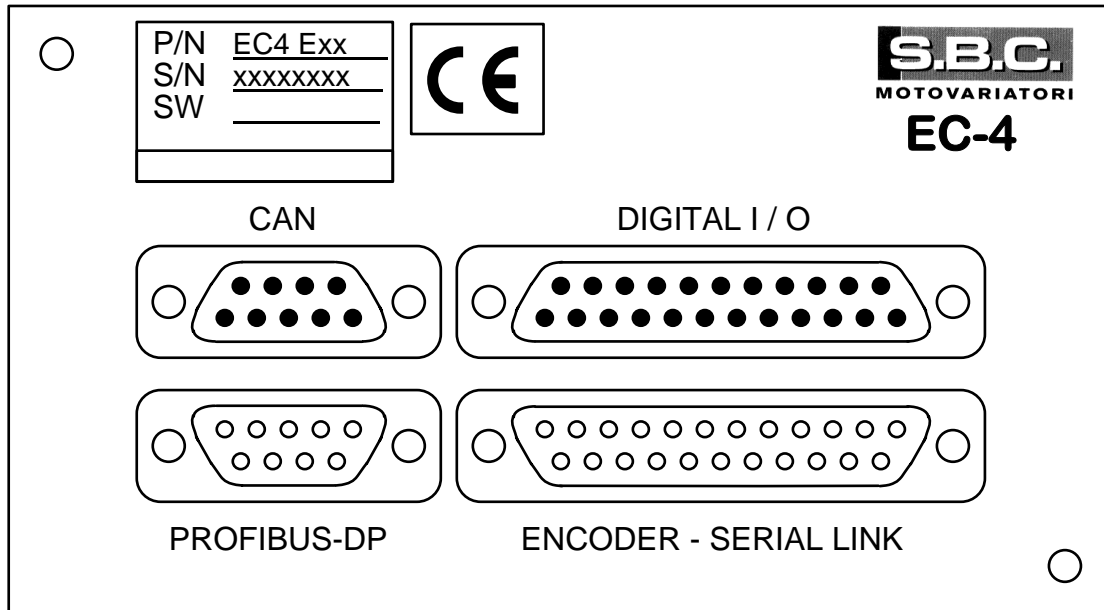

### 15.5. EC-4 installation

ATTENTION

HIGH VOLTAGE

**Before installing the EC-4 board, make surue that no wires are connected to the HPD converter.**

- Remove the lower panel
- Insert the EC-4 board
- Screw the EC-4 panel in to the body of the HPD

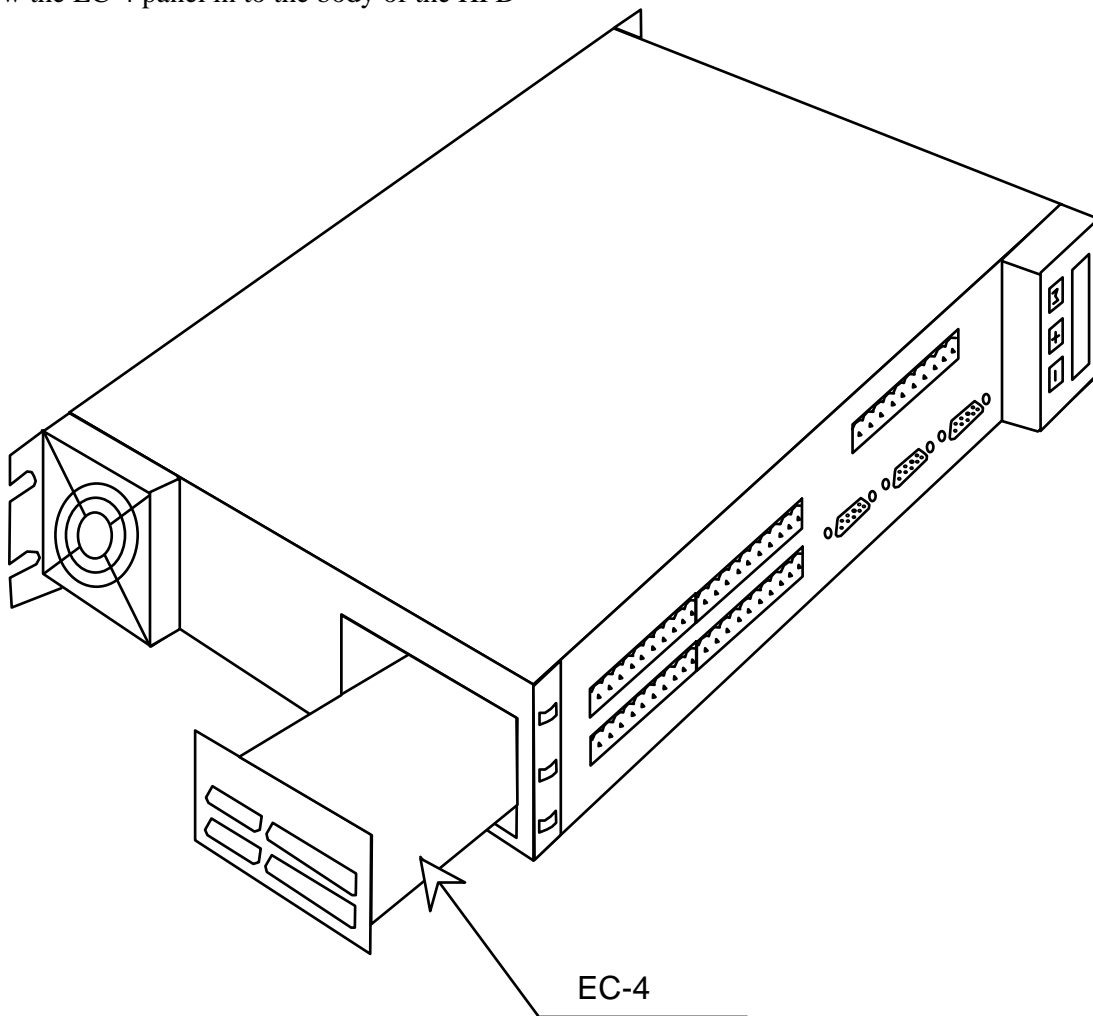



## 16. Profibus-DP connector

The Profibus-DP connector is a 9-pin female connector.

PROFIBUS-DP CONNECTOR		
N. Pin	Signal	Description
1	n.c.	
2	n.c.	
3	RxD / TxD – P	Line of communication +
4	CNTR – P	Controll signal for ripetitor
5	DGND	Ground
6	VP	Terminal supply
7	n.c.	
8	RxD / TxD – N	Line of communication –
9	n.c.	

The Profibus-DP interface is optional, and must therefore be expressly requested when ordering the EC-4 board.

The Profibus interface implemented is based on the ASIC LSPM2. The EC-4 is seen by the profibus master as a remote I/O module with 16 inputs and 16 outputs. Obviously, the I/Os are virtual. Interpretation of the meaning of the I/Os will be defined by the program installed on the EC-4 board.

The configuration file SBC0EC4.GSD is provided to configure the EC-4 as a slave Profibus-DP.

## 17. Can Bus Connector

The Can bus connector is a 9-pin male connector.

CAN BUS CONNECTOR		
N. Pin	Signal	Description
1	n.c.	
2	CAN_L	Line of communication low
3	CAN_GND	Ground
4	n.c.	
5	CAN_SHLD	Shield
6	GND	Ground
7	CAN_H	Line of communication high
8	n.c.	
9	n.c.	

Two application layers are available for the Can interface.

The first is SBCCAN, which enables master/slave communication, as well as slave/slave communication. It includes synchronism telegrams, transmissions to slave groups, and cyclic, acyclic, and interrupt transmissions. There is also a subset of SBCCAN which allows for simple data exchange between SBC drives (IDC inter-drive communication).

The second is DeviceNet. With the DeviceNet interface implemented, the EC-4 is seen by the master as a remote I/O module with 256 inputs and 256 outputs. Obviously, the I/Os are virtual. Interpretation of the meaning of the I/Os will be defined by the program installed on the EC-4 board.

## 18. Digital I/O

The Digital I/O connector is a 25-pin male connector

DIGITAL I/O CONNECTOR		
N. Pin	Signal	Description
1	DIN-0	DIGITAL INPUT 0
2	DIN-1	DIGITAL INPUT 1
3	DIN-2	DIGITAL INPUT 2
4	DIN-3	DIGITAL INPUT 3
5	DIN-4	DIGITAL INPUT 4
6	DIN-5	DIGITAL INPUT 5
7	DIN-6	DIGITAL INPUT 6
8	DIN-7	DIGITAL INPUT 7
9	+24Vin	COMMON OUT
10	+24Vin	COMMON OUT
11	+24Vin	COMMON OUT
12	+24Vin	COMMON OUT
13	+24Vin	COMMON OUT
14	DOUT-0	DIGITAL OUTPUT 0
15	DOUT-1	DIGITAL OUTPUT 1
16	DOUT-2	DIGITAL OUTPUT 2
17	DOUT-3	DIGITAL OUTPUT 3
18	DOUT-4	DIGITAL OUTPUT 4
19	DOUT-5	DIGITAL OUTPUT 5
20	DOUT-6	DIGITAL OUTPUT 6
21	DOUT-7	DIGITAL OUTPUT 7
22	0V	COMMON IN
23	0V	COMMON IN
24	0V	COMMON IN
25	0V	COMMON IN

It uses digital PNP-type inputs. The characteristics common to all inputs are as follows:

DIGITAL INPUTS		
Impedance input	6K	Ohm
VH	15...30	V
VL	0...3	V

The output that guides an input of the EC-4 board must be a PNP type and have the 0V signal connected to one of the pins from 22 to 25.

**example: EC-4 digital input connection**

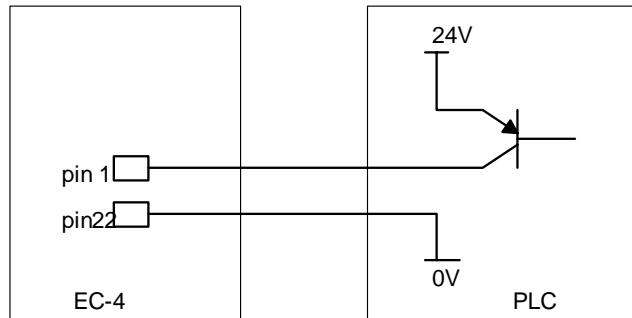

The outputs are PNP-type. The common of the outputs of pins 9..13 must be connected to an external 24V power supply. The characteristics of the outputs are:

digital outputs		
type	PNP open collector	
I/O for a single output	100	mA
Maximum total current	500	mA

**example: EC-4 digital output connection**

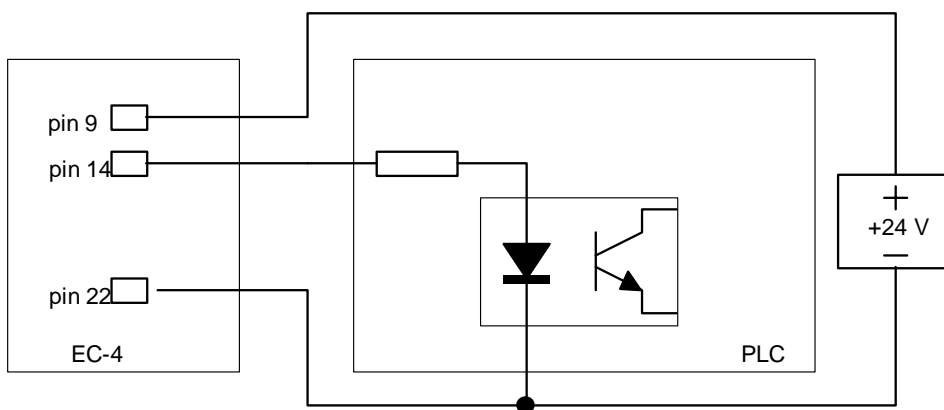

**N.B.**

**All inputs can be configured to capture values**

**All outputs can be configured to provide value comparison outputs**

## 19. Encoder and serial link

The encoder connector and serial link is a 25-pin female connector.

The pins of the encoder connector and serial link change meaning as a function of the connection and the drive software installed. The following tables present the typical configurations.

<b><i>DEBUG MODE CONNECTION</i></b>		
N. Pin	Signal	Description
1	TX+	line TX RS-422 positive
2	TX-	line TX RS-422 negative
3	RX+	line RX RS-422 positive
4	RX-	line RX RS-422 negative
6	GND	0V

With the “DEBUG MODE” connection and using an RS-422/RS-232 converter, you can connect the EC-4 board to a personal computer and, using the software installed on the PC, test the user program.

Using the same communication port, you can also load software already installed in the flash memory of the EC-4 board.

<b><i>ModBus CONNECTION</i></b>		
N. Pin	Signal	Description
1	TX+	line TX RS-422 positive
2	TX-	line TX RS-422 negative
3	RX+	line RX RS-422 positive
4	RX-	line RX RS-422 negative
6	GND	0V

The ModBus connection makes it possible to connect a ModBus-configured operator panel to the EC-4 board. To manage the ModBus, you need to load the drive software that will provide access to the entire parameter area for the operator panel.

<b><i>IncrementalEncoder CONNECTION</i></b>		
N. Pin	Signal	Description
14	A+	Phase A positive
15	A-	Phase A negative
16	B+	Phase B positive
17	B-	Phase B negative
21	GND	0V

Using the incremental encoder connection, you can connect an RS-422 5V differential auxiliary encoder. On the same connector, the voltage of the encoder itself is also available. To program the voltage see the relative table.

<b><i>Encoder SSI CONNECTION</i></b>		
N. Pin	Signal	Description
14	Data+	Line data trasmission positive
15	Data-	Line data trasmission negative
11	Clock+	Line clock positive
24	Clock-	Line clock negative
21	GND	0V

Using the SSI encoder connection, you can connect an absolute auxiliary encoder based on the SSI standard. On the same connector, the voltage of the encoder itself is also available. To program the voltage see the relative table.

<b><i>Encoder CONNECTION SUPPLY</i></b>		
N. Pin	Signal	Description
12	+V out	Encoder voltage supply
13	+V out	
25	+V out	
22	GND	0V
9	GND	0V

<b><i>Encoder supply setup</i></b>	
Voltage	Connection
5V	
8V	22 - 23
12V	9 - 10
15V	9 - 10    22 - 23

By short-circuiting the pins of the connector as shown in the table, you will have a V out able to put out 250mA which can be used to power the auxiliary encoder.

***N.B. A 220 ohm receiver-side resistor must be installed on all differential signals.***

## 20. Motion functions concepts

This is a series of software functions for the EC-4 board that can meet all modern application needs. The main characteristics are shown below.

**Speed mode** Used to generate a position profile that allows you to control the speed of the motor with the programmed acceleration limits. More than one position profile can be active at the same time.

**Positioner** Enables incremental or absolute positioning where all positioning parameters can be changed dynamically during the execution of the profile itself. More than one position profile can be active at the same time.

**Electrical shaft** Used to carry out the electrical shaft function. The master/slave relationship and the engage/disengage mode are programmable. It is possible to engage without phase recovery. With phase recovery, post- and pre-trigger functions are also available. Disengaging can be on command, automatic by module, or on command and by module.

**Electronic cam** Provides the functions of an electronic cam. The cam profile can be open or closed, continuous or by individual module. The cam profile can also be changed dynamically. The cam is described with a table of any length, and more than one cam profile can exist. The cam profile can also be described in polynomial form, and between point pairs a cubic spline interpolation can be done.

Each profile generator can be summed with another or used as input of another, resulting in a series of virtual axes.

## 21. Examples of applications

### 21.1. Power supply for presses

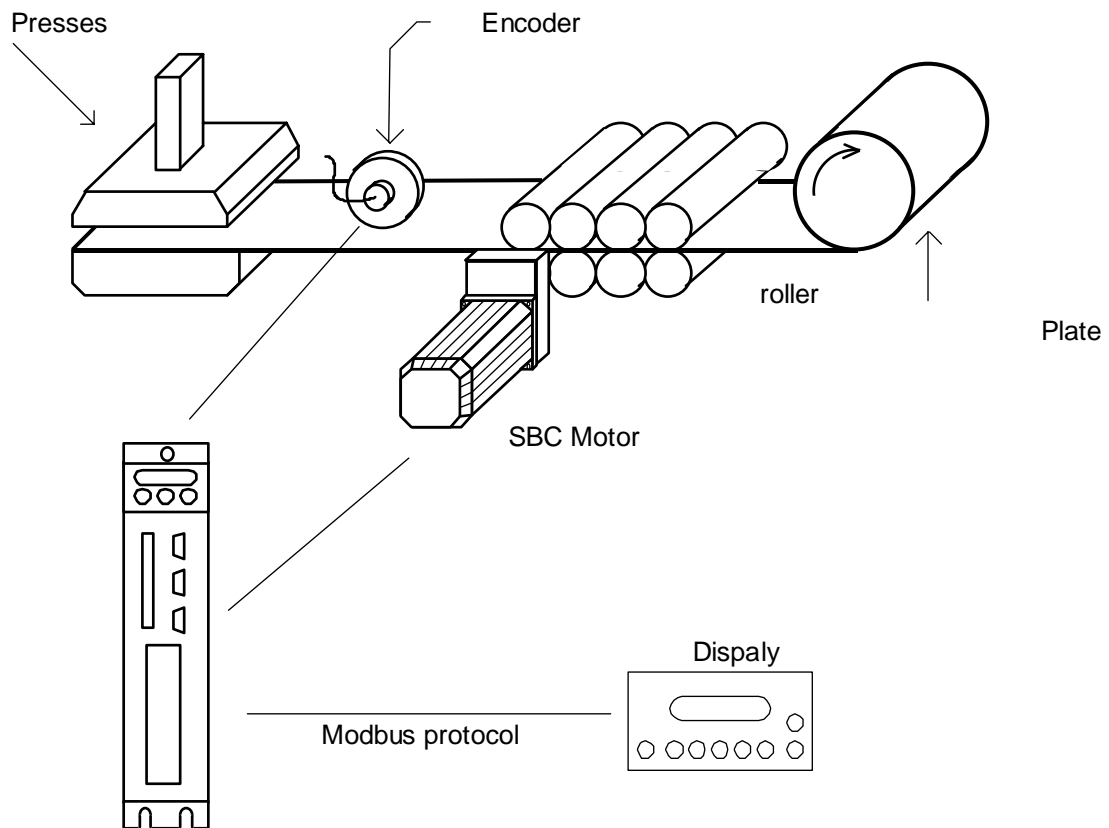

SBC Drive + EC4 expansion board

- Positioning value control on external encoder or resolver
- Press control
- Rollers closed signal
- Sheet signal
- 99 process types
- For each process, you can program: level, operating speed, and acceleration
- Jog back and forward
- Connection with display to program the system directly



**21.2. Electronic cam**

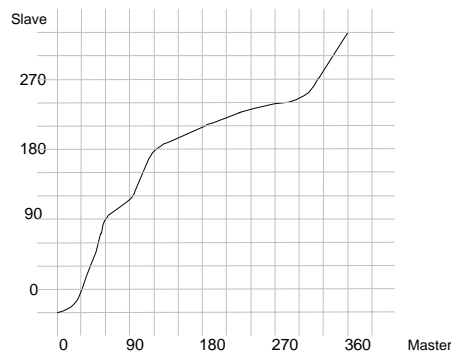
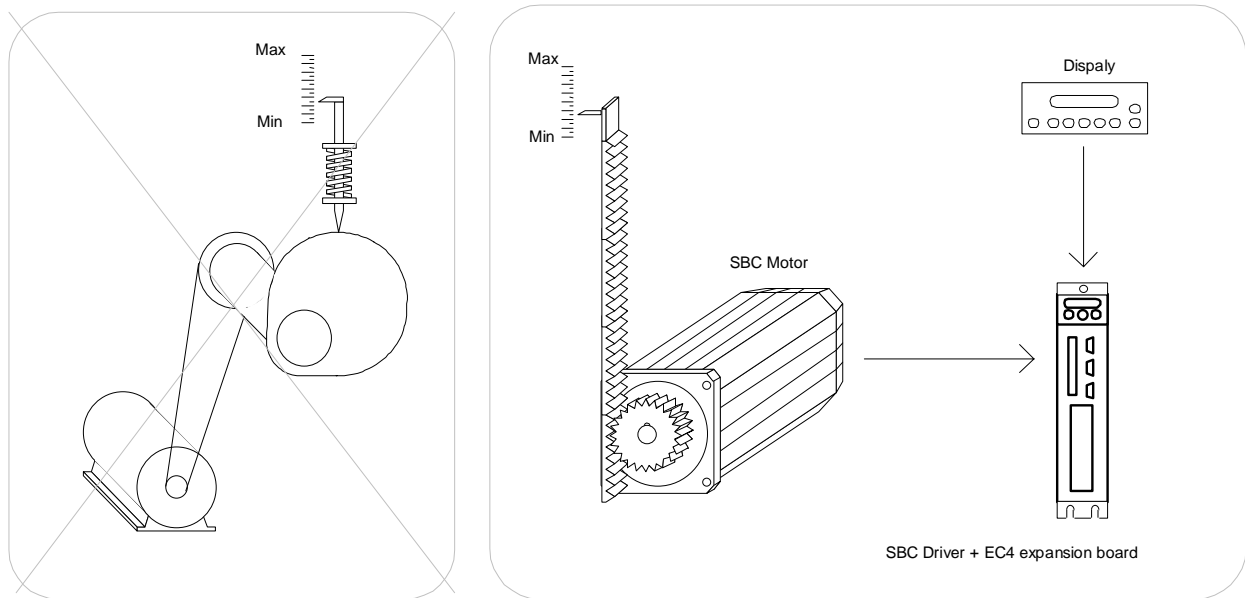

- Homing function
- Electronic cam which can be stored on the EC-4 board
- Hold function to disengage and reengage the cam at a given master position
- An external device can be connected using Profibus DB, DeviceNet, or RS-422 serial interface in order change cam points in real time.

### 21.3. Positioner with 250 preset levels

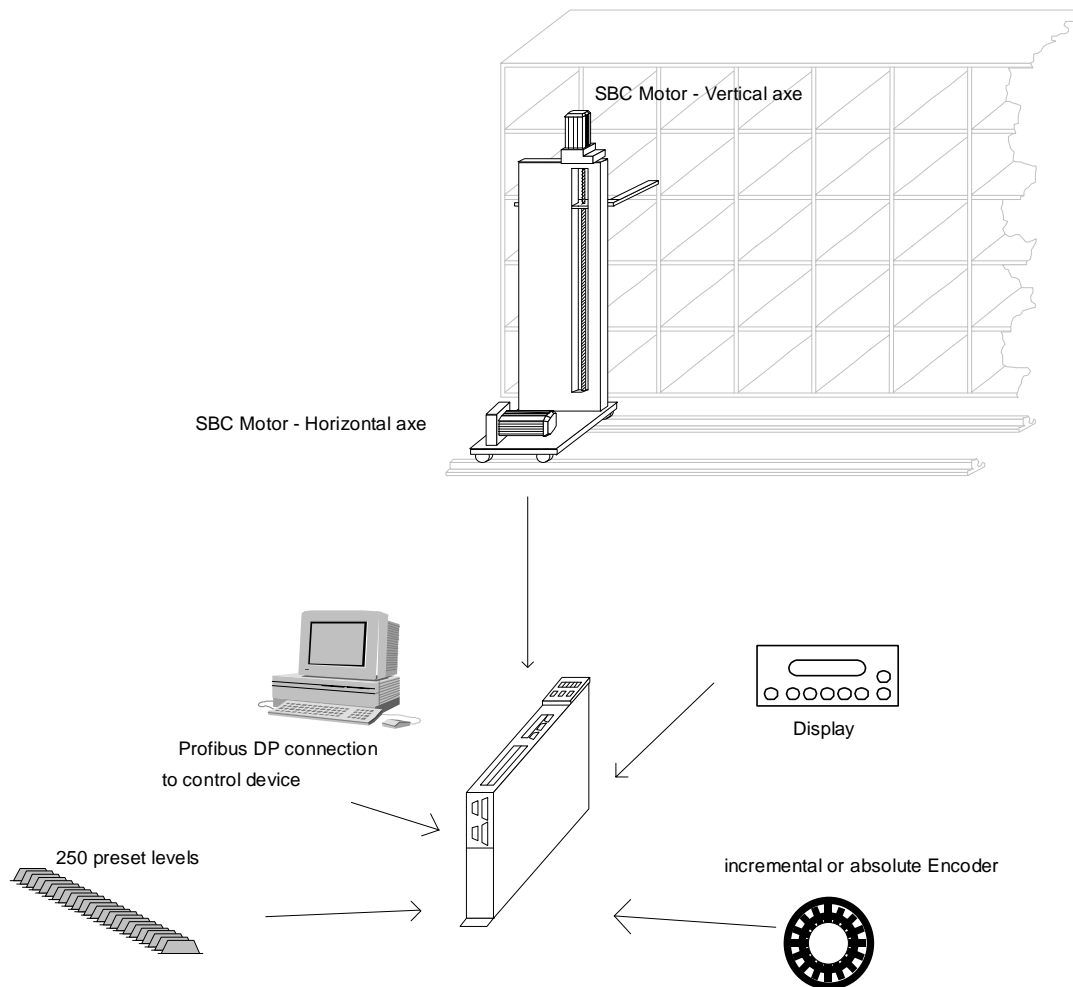

- Positioning value control on incremental or absolute SSI encoder or resolver
- 250 levels can be stored
- Jog back and forward
- A display can be connected to program and monitor the positioner
- Profibus-DP interface to manage the system

## 21.4. Two-axis extractor

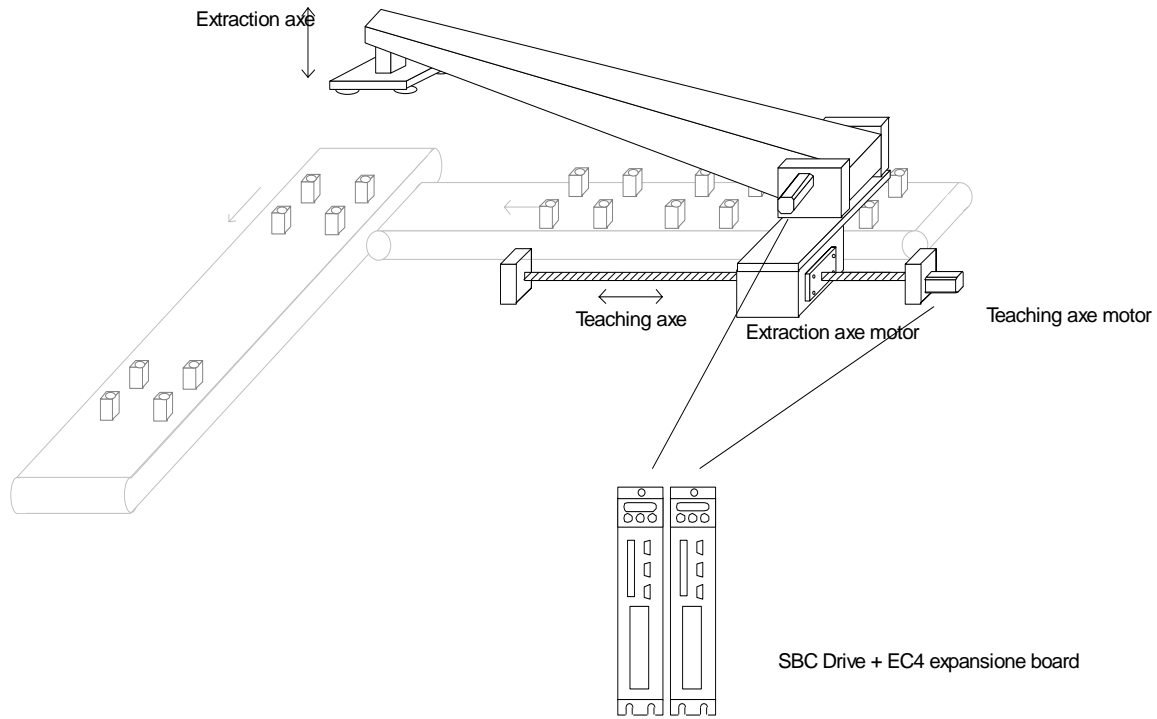

- Positioning value control on external incremental encoder, SSI encoder, or resolver
- Management of the control signals for the unloading line
- Management of the control signals for the extractor device
- Programmable feed and unload times
- Ability to program n formats
- For each process, you can program:
  - feed and unload levels
  - rapid approach values for extraction
  - Speed and acceleration of loaded extractor
  - Speed and acceleration of empty extractor
- Jog back and forward
- Ability to connect a display to program the system directly

**21.5. Vertical robot**

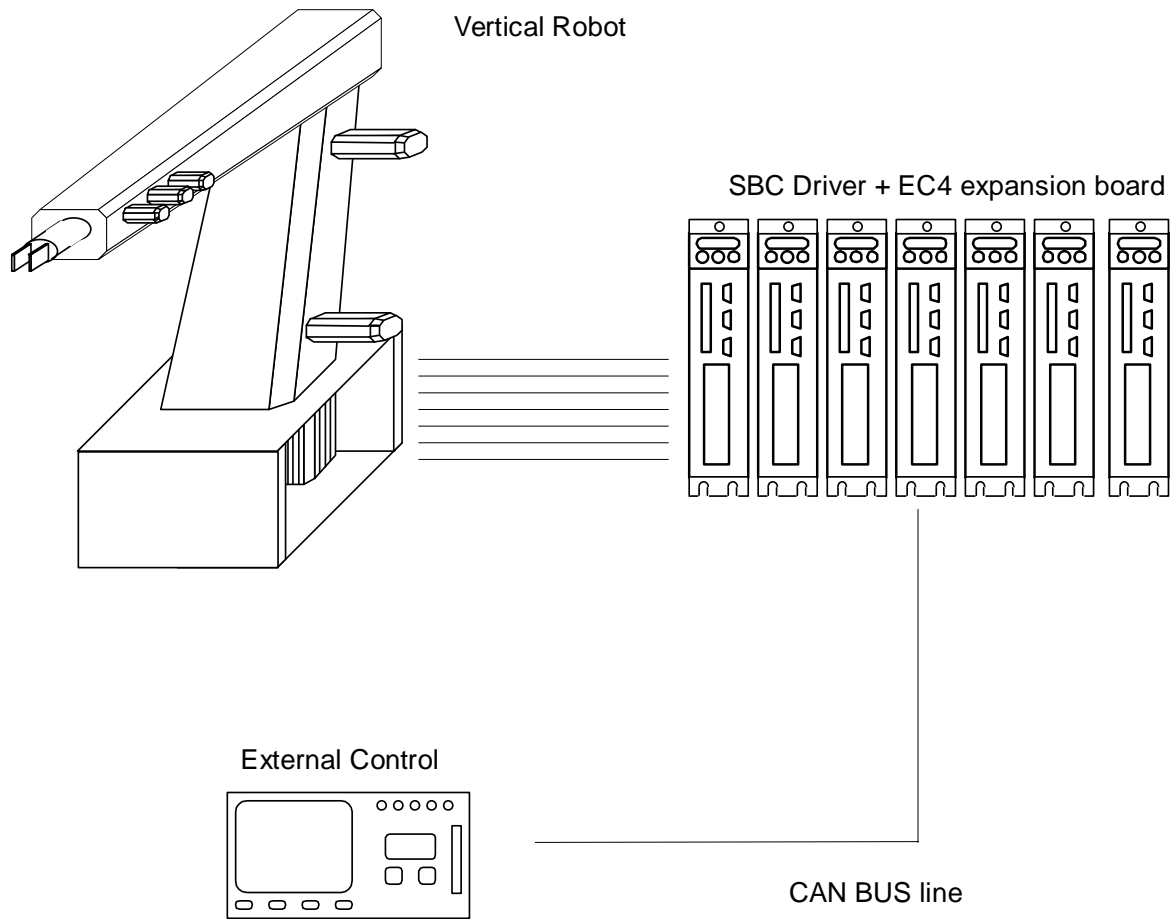

Interconnection of seven axes by SBC CAN BUS with ring management of space within control

**21.6. Continuous press**

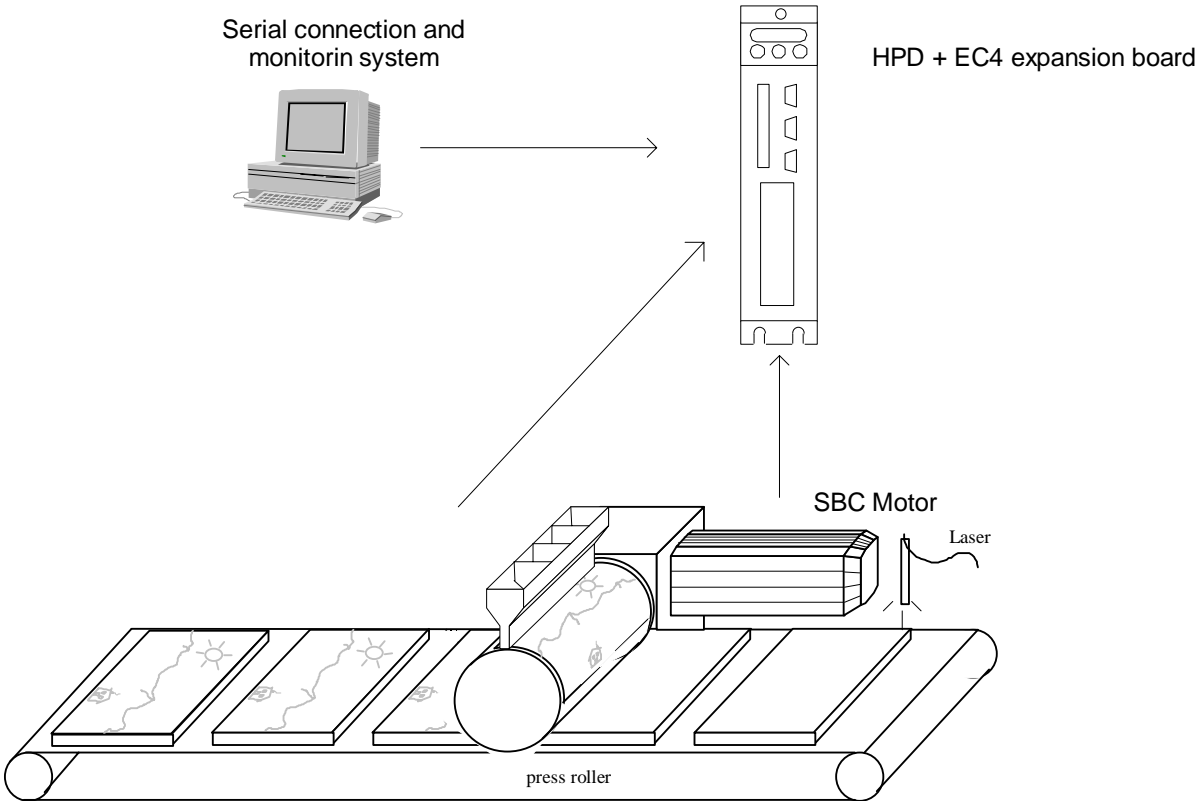

- On-the-fly correction of press module synchronism
- Serial control of motion parameters

## 21.7. On the fly cutting

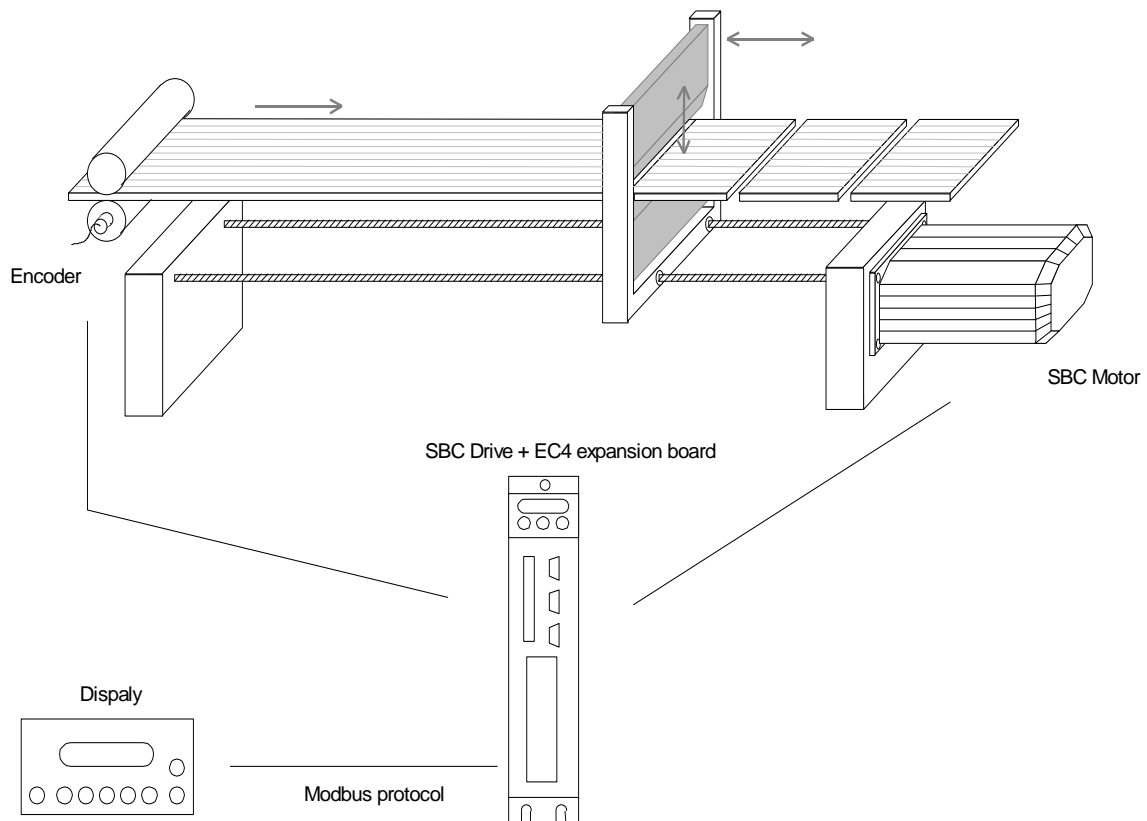

- Engage electric shaft with the line with phase recovery
- Ability to program n formats
- For each process, you can program:
  - number of consecutive pieces
  - return speed in rapid mode.
- Jog back and forward
- Ability to connect a display to program the system directly

**21.8. Heat sealer**

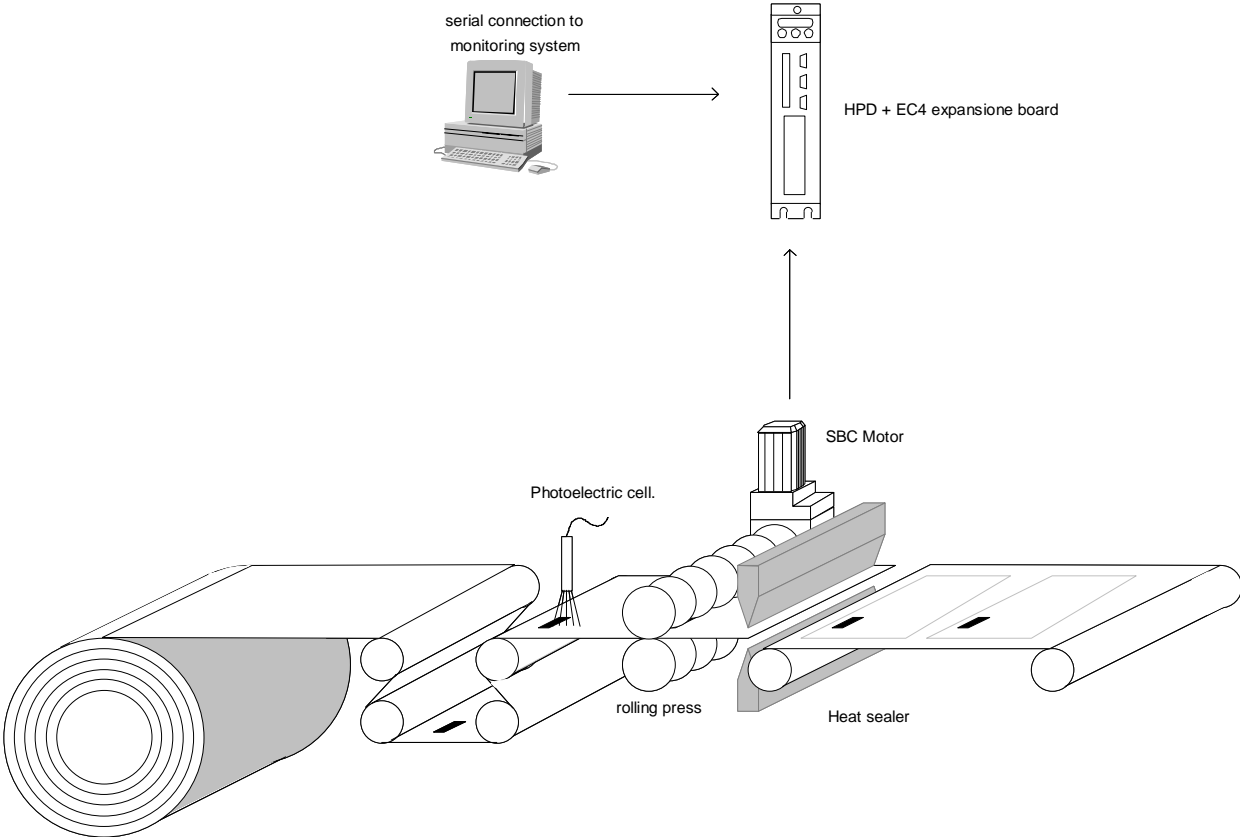

- On-the-fly correction of bag size
- Serial control of motion parameters

**22. Appendix M: external bracking modul**

**TECHNICAL CHARACTERISTICS**

Resistance value:	RFE1 = 40 ohm, RFE2 = 27 ohm
IP protection	20
Max power dissipated	1000 W
Max ambient temperature	45° C
Delta T	90° C
Weight	2,5 Kg
Ventilation power supply	24 V=

**INSTALLATION**

The RFE1 or 2 breaking module must be installed vertically as shown. A four-pole 4mm<sup>2</sup> cable must be used for the connection.

The 24v power supply used for the ventilator can cause disturbances. It is therefore a good idea not to use the same power line for electronic devices. The cable should not be longer than 4m. For the connection to the drive, see the related chapter in the converter manual and use a 30A thermo-magnetic switch.

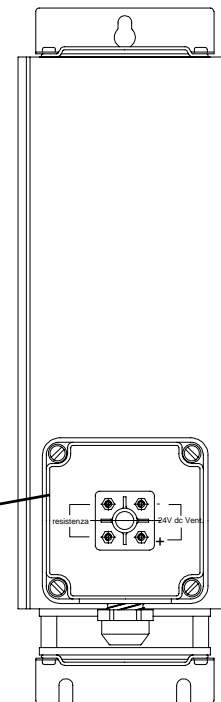

Terminal pins REF1

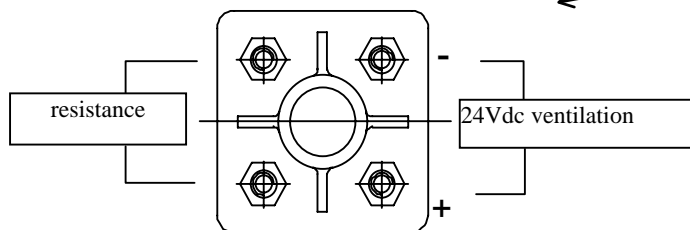



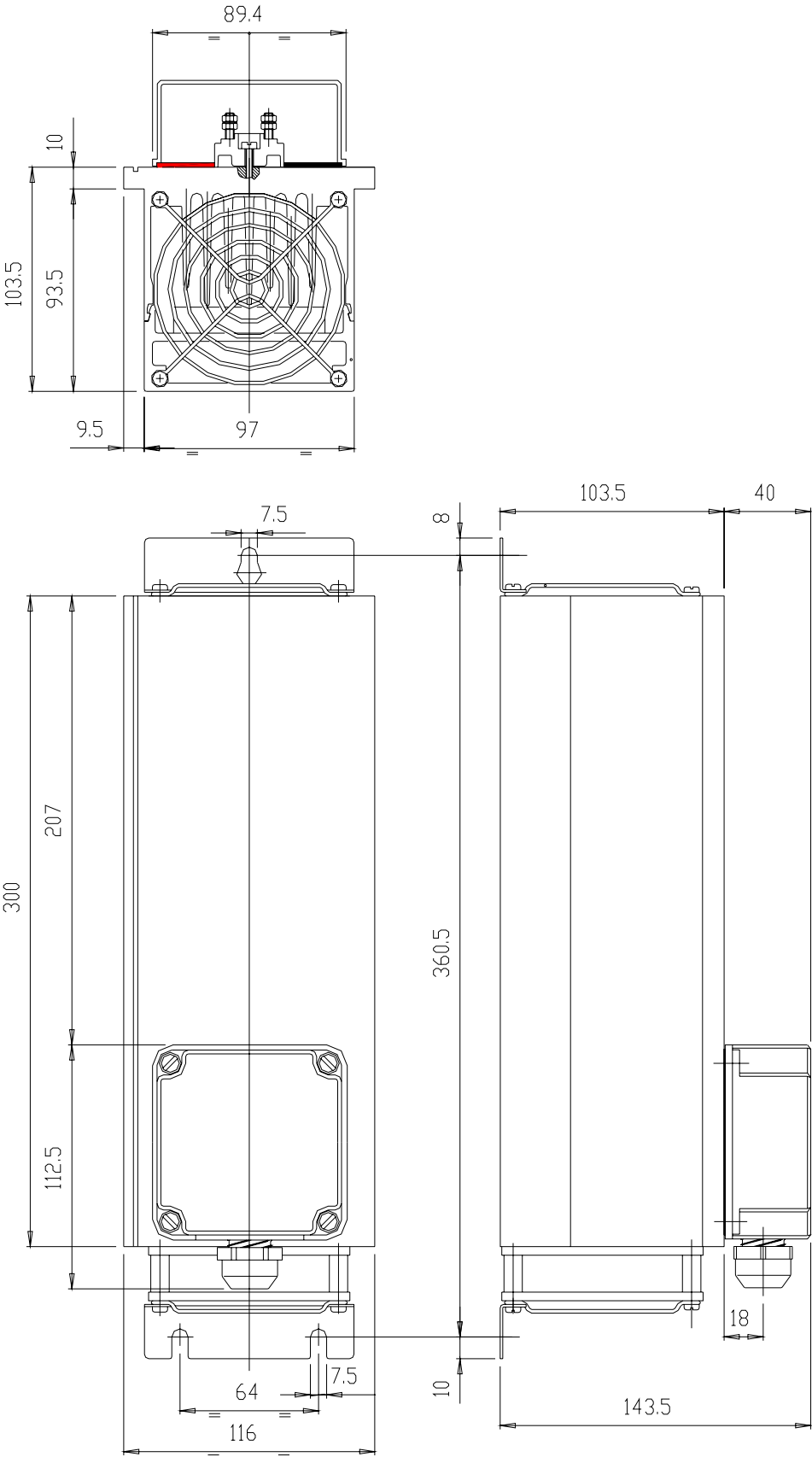

**23. Appendix N application description form**

In order to develop our products in co-ordination with user's needs, we are most interested to learn about your HPD application. Please fill in this form and return it to us. This will also enable us to tailor our technical support to your individual requirements.

**Fill in these forms in full and keep them with the machine technical documentation to facilitate maintenance.**

to: *Parker Hannifin S.p.A. - Divisione S.B.C. / ITALY*  
*R & D department*  
 fax: +39-2-66016116

CUSTOMER name .....  
 Contact name .....  
 Tel. ....  
 Fax. ....

MODEL  HPD 2  
 HPD 5  
 HPD 8  
 HPD 16

SERIAL NUMBER .....  
 MOTOR MODEL .....  
 MOTOR SERIAL NUMBER .....  
 OPERATING VOLTAGE ..... V  
 FIRST HPD APPLICATION? YES  NO   
 MACHINE TYPE .....  
 TASK PERFORMED BY AMPLIFIER.....

COMMENTS  
 .....  
 .....  
 .....  
 .....  
 .....

**FUNCTIONS USED**

<input type="checkbox"/> EXTERNAL BRAKING	<input type="checkbox"/> MAINS FILTERS	<input type="checkbox"/> ENCODER IN	<input type="checkbox"/>
<input type="checkbox"/> BACK-UP	<input type="checkbox"/> LOW VOLTAGE FUNCTION	<input type="checkbox"/> ENCODER OUT	<input type="checkbox"/>
<input type="checkbox"/> PARALLEL BUS	<input type="checkbox"/> INTERNAL PLC	<input type="checkbox"/>	<input type="checkbox"/>
<input type="checkbox"/> MOTOR COILS	<input type="checkbox"/> SERIAL LINE	<input type="checkbox"/>	<input type="checkbox"/>

**AMPLIFIER CONTROLLED BY**

	MAKE	MODEL
NUMERICAL CONTROL		
PLC		
SINGLE AXIS CARD		
MASTER/SLAVE CARD		
OTHER.....		

AMPLIFIER PROGRAMMING							
Pr	value	Pr	value	Pr	value	Pr	value
1		31		42.5		70.6	
2		32		42.6		70.7	
3		33		42.7		70.8	
4		34		50		70.9	
5		39		51		70.10	
8		40.0		52		70.11	
9		40.1		53		70.12	
10		40.2		54		70.13	
11		40.3		55		70.14	
12		40.4		56		70.15	
13		40.5		57		80	
14		40.6		58		81	
15		40.7		59		82	
16		40.8		60:61		83	
17		40.9		62:63		84	
18		40.10		64:65		85	
19		40.11		66:67		86	
23		40.12		68:69		87	
24		40.13		70.0		88	
25		40.14		70.1		89	
26		40.15		70.2		99.6	
27		42.0		70.3		99.7	
29		42.1		70.4		99.8	
30		42.2		70.5		99.13	

IF YOU USE AN INTERNAL PLC PROGRAM OTHER THAN THE DEFAULT PROGRAM, PLEASE ENCLOSE THE LISTING.

In 0		In 16		In 32		In 48	
In 1		In 17		In 33		In 49	
In 2		In 18		In 34		In 50	
In 3		In 19		In 35		In 51	
In 4		In 20		In 36		In 52	
In 5		In 21		In 37		In 53	
In 6		In 22		In 38		In 54	
In 7		In 23		In 39		In 55	
In 8		In 24		In 40		In 56	
In 9		In 25		In 41		In 57	
In 10		In 26		In 42		In 58	
In 11		In 27		In 43		In 59	
In 12		In 28		In 44		In 60	
In 13		In 29		In 45		In 61	
In 14		In 30		In 46		In 62	
In 15		In 31		In 47		In 63	

## 24. Rervision history of the User's Manual

- Rev. 8.2                      January 2004
- sizing resistance of braking, sketch of connection
  - procedure low tension
  - given adjournment from the addendum
  - appendix on form of external braking from 1kW
  - adjournment charts, graphic, notes and name of the group
  - data of new series: drive HPD20N and HPD24N
  - adjournment sketch of filters
  - appendix L, M, N, O, examples for some applications, motion
  - adjournment sketch of serial connection rs485, rs422
  - revision history of the manual
- rev 8.3                                      February 2004
- correction to resolver cable
  - low voltage procedure
  - external braking resistance
  - external braking module
  - adjournment by addendum
  - EC4 expansion board
  - Profibus connector
  - Canbus connector
  - Digital I/O
  - Encoder and serial link
  - Alarms
  - Examples of application
  - Adjournment tables and drawings
  - Pr37 removed
  - Adjournment sketch RS485-RS422
  - Filters and motors appendixes removed
- Rev8.4                                      March 2004
- correction to Pr34
- Rev8.5                                      November 2004
- declaration of conformity
  - note about restricted sales
  - Adjournment sketch braking resistor
  - Connection diagrams for frequency/direction signals

*For other information log into website [www.sbcelettronica.com](http://www.sbcelettronica.com). Arranges to the manual data can be made by the manufacturer without advance notice. The data shown in the manual correspond to the specifications relating to the revision date*



# Divisione S.B.C.



## Worldwide distribution

### EUROPE

#### BELGIUM, LUXEMBURG PROCOTEC BVBA

Lieven Bauwensstraat 25A  
8200 Brugge (Industriezone Waggelwater)  
Tel. +32-50-320611 - Fax +32-50-320688  
www.procotec.be - info@procotec.be

#### DENMARK SERVOTECH AS

Ulvhavevej 42-46 - 7100 VEJLE  
Tel. +45-7942-8080 - Fax. +45-7942-8081  
www.servotech.dk - servotech@servotech.dk

#### FRANCE TRANSTECHNIK SERVOMECHANISMES S.A.

Z.A. Ahuy Suzon  
17 Rue Des Grandes Varennes - 21121 Ahuy  
Tel. +33-380-550000 - Fax +33-380-539363  
www.transtechnik.fr - info@transtechnik.fr

#### GREAT BRITAIN AMIR POWER TRANSMISSION LTD

Amir House, Maxted Road - Hemel Hempstead  
Hertfordshire - HP2 7DX  
Tel +44-1442-212671 - Fax +44-1442-246640  
www.amirpower.co.uk - apt@amirpower.co.uk

#### QUIN SYSTEMS LIMITED

Oakland Business Centre  
Oakland Park - Wokingham  
Berkshire - RG41 2FD - U.K.  
Tel. +44-118-9771077 - Fax +44-118-9776728  
www.quin.co.uk - sales@quin.co.uk

#### HOLLAND VARIODRIVE AANDRIJF-EN BESTURINGSTECHNIEK B.V

A. van Leeuwenhoekstraat 22  
3261 LT Oud-Beijerland  
Tel. +31-186-622301 - Fax +31-186-615228  
www.variodrive.nl - sales@variodrive.nl

#### PORTUGAL SIEPI LDA

Parque Industrial do Arneiro, Lote 46  
São Julião do Tojal - 2660-456 Loures  
Tel. +351-21-9737330 - Fax +351-21-9737339  
www.gruposiepi.com - Siepi@mail.Telepac.Pt

#### SPAIN INTRA AUTOMATION SL

C/ALABAU, 20 Horno Alcedo  
E-46026 Valencia  
Tel. +34-96-3961008 - Fax +34-96-3961018  
www.intraautomationsl.com  
info@intraautomationsl.com

#### SWITZERLAND INDUR ANTRIEBSTECHNIK AG

Margarethenstrasse 87  
CH - 4008 Basel  
Tel. +41-61-2792900 - Fax +41-61-2792910  
www.indur.ch - info@indur.ch

#### TURKEY SANPA LTD STI

Plaj Yolu, Ersoy Apt. No. 14 D, 4  
34740 Suadiye - Istanbul  
Tel. +90-216-4632520 - Fax +90-216-3622727  
www.sanpald.com.tr - sanpa@turk.net

### NORTH AMERICA

#### CANADA PARS ROBOTICS GROUP INC.

441 Esna Park Drive, units 11-12  
Markham, Ontario, L3R 1H7  
Tel. +1-905-4772886 - Fax +1-905-4770980  
www.parsrobotics.com - pars@parsrobotics.com

#### UNITED STATES PARKER HANNIFIN CORPORATION COMPUMOTOR DIVISION

5500 Business Park Drive  
Rohnert Park, CA 94928  
Tel. +1-707-5847558 - Fax +1-707-5842446  
www.compumotor.com  
CMR\_Customer\_Service@parker.com

### CENTRAL AMERICA

#### MEXICO PARKER HANNIFIN DE MÉXICO

Eje 1 Norte No. 100  
Parque Ind. Toluca 2000 - Toluca 50100  
Tel. +52 722 - 2754200 - Fax +52 722 - 2799308  
www.parker.com

### SOUTH AMERICA

#### ARGENTINA, CILE, PARAGUAY, URUGUAY R.A. INGENIERIA ELECTRONIC IND. Y COM.

Arregui 5382 - 1408 Buenos Aires  
Tel. +54-11-45675543 - Fax +54-11-45662870  
www.raing.com.ar - ra@raing.com.ar

#### BRAZIL AUTOMOTION LTDA.

Acesso Jose Sartorelli Km2,1  
Parque das Arvores, 18550-000 Boituva - SP  
Tel. +55 15 33639900 - Fax +55 15 33639911  
www.automotion.com.br - coml@automotion.com.br

#### VENEZUELA TEKNOMAQ C.A.

Avenida Manuel Diaz Rodriguez  
Edif. Milano Local C  
Santa Monica - Caracas  
Tel. +58-212-6335657 - Fax +58-212-6330466  
teknomaq@cantv.net

### ASIA

#### ISRAEL AF ELECTRONICS MOTOR CONTROL

PO BOX 741  
52322 Ramat-Gan Israel  
Tel. +972-3-6745457 - Fax +972-3-6776342  
afmotor@zahav.net.il

#### MALAYSIA PRESTIGE MACHINERY

No. 46, Jalan Bateri 34/5  
Bukit Kemuning Light Industrial Area  
42450 Shah Alam - Sengalor D.E.  
Tel. +60-3-5880-9851 - Fax +60-3-5880-8364  
presmach@maxis.net.my

#### TAIWAN AUTO ACCURACY CO. LTD

No. 18, 35RD, Taichung Industrial Park  
Taichung City  
Tel. +886-42-3594847 - Fax +886-42-3591083  
www.autoaccuracy.com.tw - autoauto@ms2.hinet.net

### OCEANIA

#### AUSTRALIA, NEW ZEALAND MOTION SOLUTIONS AUSTRALIA PTY LTD

Factory 2, 21-29 Railway Avenue  
Huntingdale, 3166  
Melbourne, Victoria  
Tel. +613-9563-0115 - Fax +613-9568-4667  
www.motion-solutions.com.au  
sales@motion-solutions.com.au



**Parker Hannifin S.p.A.**  
Electromechanical Automation  
Via Gounod 1  
20092 Cinisello Balsamo (MI), Italia  
Tel: +39 0266012459  
Fax: +39 0266012808  
www.sbcelettronica.com  
sales.sbc@parker.com

**Parker Hannifin GmbH**  
Electromechanical Automation  
Robert-Bosch-Str. 22  
D-77656 Offenburg, Germania  
Tel: +49 (0)781 509-0  
Fax: +49 (0)781 509-98-258  
www.parker-emd.com  
sales.hauser@parker.com

**Parker Hannifin plc**  
Electromechanical Automation  
21 Balena Close  
Poole, Dorset. BH17 7DX UK  
Tel: +44 (0)1202 50 6200  
Fax: +44 (0)1202 69 5750  
www.parker-emd.com  
sales.digiplan@parker.com