

# ACOPOS

## User's Manual

Version: **2.00 (December 2012)**  
Model no.: **MAACP2-ENG**

All information contained in this manual is current as of its creation/publication. B&R reserves the right to change the contents of this manual without notice. The information contained herein is believed to be accurate as of the date of publication; however, Bernecker + Rainer Industrie-Elektronik Ges.m.b.H. makes no warranty, expressed or implied, with regard to the products or documentation contained within this manual. In addition, Bernecker + Rainer Industrie-Elektronik Ges.m.b.H. shall not be liable for any incidental or consequential damages in connection with or arising from the furnishing, performance or use of the product(s) in this documentation. Software names, hardware names and trademarks are registered by their respective companies.



**Chapter 1: General information**

**Chapter 2: Technical data**

**Chapter 3: Installation**

**Chapter 4: Dimensioning**

**Chapter 5: Wiring**

**Chapter 6: Safety technology**

**Chapter 7: Standards and certifications**



<b>Chapter 1 General information.....</b>	<b>11</b>
1 Manual history.....	11
2 ACOPOS.....	12
2.1 High-performance servo drive design.....	12
2.2 More room for innovation.....	12
2.3 Maximum safety.....	13
2.4 Modular and precise with communication options.....	14
2.5 Configuring instead of programming.....	15
2.6 PLCopen motion control function blocks.....	16
2.7 Higher productivity with Smart Process Technology.....	16
2.8 ACOPOS – Perfect for CNC applications as well.....	16
2.9 Quick and easy commissioning.....	17
2.10 Tools for straightforward and efficient diagnostics.....	18
3 ACOPOS configurations.....	19
3.1 ACOPOS in a POWERLINK network.....	19
3.1.1 Recommended topology for POWERLINK networks.....	20
3.1.2 Further literature.....	20
3.2 Compact, modular motion control applications.....	20
3.3 Extensive, modular motion control applications with up to 253 axes.....	21
3.4 ACOPOS in a CAN bus network.....	21
3.5 Drive-based control.....	22
4 Safety guidelines.....	23
4.1 Organization of safety notices.....	23
4.2 General information.....	23
4.3 Intended use.....	23
4.4 Protection against electrostatic discharge.....	23
4.4.1 Packaging.....	24
4.4.2 Guidelines for proper ESD handling.....	24
4.5 Transport and storage.....	24
4.6 Installation.....	25
4.7 Operation.....	25
4.7.1 Protection against touching electrical parts.....	25
4.7.2 Protection against hazardous movements.....	26
4.7.3 Protection against burns.....	26
4.8 Specifications for functional safety.....	26
4.9 Environmentally friendly disposal.....	27
4.9.1 Separation of materials.....	27
<b>Chapter 2 Technical data.....</b>	<b>29</b>
1 Module overview.....	29
2 ACOPOS servo drives.....	31
2.1 Overview.....	32
2.1.1 24 VDC supply during power failures.....	32
2.2 Status indicators.....	33
2.2.1 LED status.....	34
2.3 ACOPOS 1010, 1016.....	35
2.3.1 ACOPOS 8V1010.0xx-2.....	35
2.3.2 ACOPOS 8V1010.5xx-2.....	38
2.3.3 ACOPOS 8V1016.0xx-2.....	41
2.3.4 ACOPOS 8V1016.5xx-2.....	45
2.3.5 Wiring.....	48
2.4 ACOPOS 1022, 1045, 1090.....	56
2.4.1 ACOPOS 1022.....	56
2.4.2 ACOPOS 1045.....	59
2.4.3 ACOPOS 1090.....	62
2.4.4 Wiring.....	65
2.5 ACOPOS 1180, 1320.....	72

2.5.1 ACOPOS 1180.....	72
2.5.2 ACOPOS 1320.....	76
2.5.3 Wiring.....	80
2.6 ACOPOS 1640, 128M.....	87
2.6.1 ACOPOS 1640.....	87
2.6.2 ACOPOS 128M.....	91
2.6.3 Wiring.....	95
3 ACOPOS plug-in modules.....	102
3.1 General information.....	102
3.2 AC110 - CAN Interface.....	102
3.2.1 General information.....	102
3.2.2 Order data.....	102
3.2.3 Technical data.....	102
3.2.4 Setting the CAN station number.....	103
3.2.5 Status indicators.....	103
3.2.6 Firmware.....	103
3.2.7 Wiring.....	103
3.3 AC114 - POWERLINK V2 Interface.....	105
3.3.1 General information.....	105
3.3.2 Order data.....	105
3.3.3 Technical data.....	105
3.3.4 Setting the POWERLINK station number.....	106
3.3.5 Status indicators.....	106
3.3.6 Firmware.....	106
3.3.7 Wiring.....	107
3.4 AC120 - EnDat encoder interface.....	108
3.4.1 General information.....	108
3.4.2 Order data.....	108
3.4.3 Technical data.....	109
3.4.4 Status indicators.....	110
3.4.5 Firmware.....	110
3.4.6 Wiring.....	110
3.5 AC121 - HIPERFACE encoder interface.....	112
3.5.1 General information.....	112
3.5.2 Order data.....	112
3.5.3 Technical data.....	112
3.5.4 Status indicators.....	113
3.5.5 Firmware.....	113
3.5.6 Wiring.....	113
3.6 AC122 - Resolver interface.....	115
3.6.1 General information.....	115
3.6.2 Order data.....	115
3.6.3 Technical data.....	115
3.6.4 Status indicators.....	116
3.6.5 Wiring.....	117
3.7 AC123 - Incremental encoder and SSI absolute encoder interface.....	118
3.7.1 General information.....	118
3.7.2 Order data.....	118
3.7.3 Technical data.....	118
3.7.4 Status indicators.....	119
3.7.5 Firmware.....	119
3.7.6 Wiring.....	120
3.8 AC125 - BiSS encoder interface.....	122
3.8.1 General information.....	122
3.8.2 Order data.....	122
3.8.3 Technical data.....	122
3.8.4 Status indicators.....	123

3.8.5 Firmware.....	123
3.8.6 Wiring.....	123
3.9 AC126 - EnDat 2.2 interface.....	124
3.9.1 General information.....	124
3.9.2 Order data.....	124
3.9.3 Technical data.....	124
3.9.4 Status indicators.....	125
3.9.5 Firmware.....	125
3.9.6 Wiring.....	126
3.10 AC130 - Digital mixed module.....	127
3.10.1 General information.....	127
3.10.2 Order data.....	127
3.10.3 Technical data.....	127
3.10.4 Status indicators.....	129
3.10.5 Firmware.....	129
3.10.6 Wiring.....	129
3.11 AC131 - Mixed module.....	131
3.11.1 General information.....	131
3.11.2 Order data.....	131
3.11.3 Technical data.....	131
3.11.4 Status indicators.....	133
3.11.5 Firmware.....	133
3.11.6 Wiring.....	133
3.12 AC140 - CPU module.....	135
3.12.1 General information.....	135
3.12.2 Order data - 8AC140.60-3.....	135
3.12.3 Order data - 8AC140.61-3.....	136
3.12.4 Technical data.....	136
3.12.5 Status indicators.....	139
3.12.6 Setting the CAN station number (IF2).....	139
3.12.7 Setting the PROFIBUS station number (IF3).....	139
3.12.8 Setting the Ethernet station number (IF6).....	140
3.12.9 Reset button.....	140
3.12.10 Slot for application memory (CompactFlash).....	140
3.12.11 Backup battery.....	140
3.12.12 Input/Output registers.....	143
3.12.13 Wiring.....	144
3.13 AC141 - CPU module.....	146
3.13.1 General information.....	146
3.13.2 Order data.....	146
3.13.3 Technical data.....	147
3.13.4 Status indicators.....	150
3.13.5 Setting the CAN station number (IF2).....	150
3.13.6 Setting the CAN station number (IF3).....	150
3.13.7 Setting the Ethernet station number (IF6).....	150
3.13.8 Reset button.....	151
3.13.9 Slot for application memory (CompactFlash).....	151
3.13.10 Backup battery.....	151
3.13.11 Input/Output registers.....	154
3.13.12 Wiring.....	155
4 8B0W external braking resistors.....	157
4.1 Order data.....	157
4.2 Technical data.....	157
4.3 Wiring.....	158
4.3.1 8B0W braking resistors - Pinout.....	158
5 Cables.....	160
5.1 General information.....	160

5.1.1 Assembled cables.....	160
5.2 Motor cables.....	160
5.2.1 0.75 mm <sup>2</sup> motor cables.....	160
5.2.2 1.5 mm <sup>2</sup> motor cables.....	162
5.2.3 4 mm <sup>2</sup> motor cables.....	164
5.2.4 10 mm <sup>2</sup> motor cables.....	166
5.2.5 35 mm <sup>2</sup> motor cables.....	168
5.2.6 Wiring.....	169
5.3 EnDat cables.....	172
5.3.1 Order data.....	172
5.3.2 Technical data.....	172
5.3.3 Wiring.....	173
5.4 Resolver cables.....	175
5.4.1 Order data.....	175
5.4.2 Technical data.....	175
5.4.3 Wiring.....	176
6 Connectors.....	178
6.1 General information.....	178
6.2 Motor connectors.....	178
6.2.1 Order data.....	178
6.2.2 Technical data.....	178
6.3 Encoder connectors.....	180
6.3.1 EnDat connectors.....	180
6.3.2 Resolver connectors.....	181
<b>Chapter 3 Installation.....</b>	<b>183</b>
1 General.....	183
2 Dimension diagrams and installation dimensions.....	184
2.1 ACOPOS 1010, 1016.....	184
2.2 ACOPOS 1022, 1045, 1090.....	185
2.3 ACOPOS 1180, 1320.....	186
2.4 ACOPOS 1640.....	187
2.5 ACOPOS 128M.....	188
2.6 External braking resistors.....	189
2.6.1 8B0W0045H000.001-1, 8B0W0079H000.001-1.....	189
3 Installing and removing plug-in modules.....	191
3.1 General information.....	191
3.2 Installation.....	191
3.3 Removal.....	192
4 Installing devices from different ACOPOS series directly next to each other.....	193
5 Using cooling systems in control cabinets.....	194
5.1 Natural convection.....	194
5.2 Using filter fans.....	194
5.3 Using air/air heat exchangers.....	195
5.4 Using air/water heat exchangers.....	196
5.5 Using cooling units.....	197
5.5.1 General information.....	197
5.5.2 Placing a cooling unit on top of the control cabinet.....	197
5.5.3 Placing a cooling unit on the front of the control cabinet.....	198
6 Motor cables.....	199
6.1 Assembly example (module-side) of a 1.5 mm <sup>2</sup> motor cable.....	199
<b>Chapter 4 Dimensioning.....</b>	<b>203</b>
1 Power mains connection.....	203
1.1 General information.....	203
1.1.1 Mains configurations.....	203
1.1.2 Supply voltage range.....	204

1.1.3 Protective ground connection (PE).....	204
1.2 Dimensioning.....	206
1.2.1 Individual ACOPOS power mains connections.....	206
1.2.2 Implementing ACOPOS power mains connections for drive groups.....	209
1.3 Fault current protection.....	211
1.3.1 Rated fault current.....	211
1.3.2 Estimating the discharge current.....	211
1.3.3 Manufacturer used.....	211
2 DC bus.....	212
2.1 General information.....	212
2.2 Wiring design.....	213
2.3 Equal distribution of the applied power via the power rectifiers.....	213
2.4 Equal distribution of the brake power on the braking resistors.....	214
2.5 Connecting external DC bus power supplies.....	214
3 Motor connection.....	215
4 Braking resistors.....	216
4.1 General information.....	216
4.2 External braking resistor connections.....	217
4.2.1 Fuse protection.....	218
4.3 Dimensioning the braking resistor.....	219
4.3.1 Basis of the calculation.....	219
4.3.2 Example.....	222
4.4 Configuring brake resistor parameters.....	227
4.4.1 Using the integrated braking resistors.....	227
4.4.2 Using external braking resistors.....	227
5 Configuring ACOPOS servo drives.....	228
5.1 Maximum power output for all slots on the ACOPOS servo drive.....	228
5.2 24 VDC current requirements for the ACOPOS servo drive.....	229
6 Dimensioning cooling systems for cooling control cabinets.....	230
6.1 General dimensioning criteria.....	230
6.1.1 Basic selection of the cooling system.....	230
6.2 Natural convection.....	231
6.2.1 Dimensioning.....	231
6.2.2 Example.....	231
6.3 Filter fans.....	232
6.3.1 Dimensioning.....	232
6.3.2 Example.....	232
6.4 Air/air heat exchangers.....	234
6.4.1 Dimensioning.....	234
6.4.2 Example.....	234
6.5 Air/water heat exchangers / Cooling units.....	235
6.5.1 Dimensioning.....	235
6.5.2 Example.....	235
7 Formula variables used.....	237

## **Chapter 5 Wiring..... 239**

1 General information.....	239
1.1 Electromagnetic compatibility of the installation.....	239
1.1.1 General information.....	239
1.1.2 Installation guidelines.....	239
1.2 Insulation and high voltage testing.....	243
1.2.1 Insulation resistance testing in accordance with EN 60204.....	243
1.2.2 High voltage testing.....	243
1.3 Connecting cables to plug-in modules.....	244
1.4 Overview of clampable cross sections.....	245

<b>Chapter 6 Safety technology</b> .....	<b>247</b>
1 Standard safety technology ("Wired safety technology").....	247
1.1 General information.....	247
1.2 Principle - Implementing the safety function.....	248
1.2.1 Additional function.....	249
1.3 Enable input connected in accordance with Safety Category 3 / SIL 2 / PL d.....	250
1.3.1 STO, Category 3 / SIL 2 / PL d (Variant A).....	250
1.3.2 STO, Category 3 / SIL 2 / PL d (Variant B).....	251
1.4 Enable input circuits in accordance with Safety Category 3 / SIL 2 / PL d and functionality (STO, SS1, SS2, SLS, SOS).....	252
1.4.1 STO, SLS, SOS - Safety Category 3 / SIL 2 / PL d.....	252
1.4.2 SS1, SLS, SS2 - Safety Category 3 / SIL 2 / PL d (Variant A).....	254
1.4.3 SS1, SLS, SS2 - Safety Category 3 / SIL 2 / PL d (Variant B).....	256
 <b>Chapter 7 Standards and certifications</b> .....	 <b>259</b>
1 Applicable European directives.....	259
2 Applicable standards.....	259
3 Environmental limits.....	260
3.1 Mechanical conditions in accordance with IEC 61800-2.....	260
3.1.1 Operation.....	260
3.1.2 Transport.....	260
3.2 Climate conditions in accordance with IEC 61800-2.....	260
3.2.1 Operation.....	260
3.2.2 Storage.....	260
3.2.3 Transport.....	260
4 Requirements for immunity to disturbances (EMC).....	261
4.1 Evaluation criteria (performance criteria).....	261
4.2 Low-frequency disturbances in accordance with IEC 61800-3.....	261
4.2.1 Power mains harmonics and commutation notches / voltage distortions.....	261
4.2.2 Voltage changes, fluctuations, dips and short-term interruptions.....	261
4.2.3 Asymmetric voltages and frequency changes.....	261
4.3 High-frequency disturbances in accordance with IEC 61800-3.....	262
4.3.1 Electrostatic discharge.....	262
4.3.2 Electromagnetic fields.....	262
4.3.3 Burst.....	262
4.3.4 Surge.....	262
4.3.5 High-frequency conducted disturbances.....	262
5 Requirements for emissions (EMC).....	263
5.1 High-frequency emissions in accordance with IEC 61800-3.....	263
5.1.1 Disturbance voltages on the power connections.....	263
5.1.2 Electromagnetic emissions.....	263
6 Other environmental limit values in accordance with IEC 61800-2.....	263
7 International certifications.....	264
8 Standards and definitions for safety technology.....	265

# Chapter 1 • General information

## 1 Manual history

### Information:

B&R works hard to keep the printed versions of its user's manuals as current as possible. However from a safety standpoint, the current version from the B&R website must be used ([www.br-automation.com](http://www.br-automation.com)) .

Version	Date	Comment
2.00	12/12/2012	Changes / New features <ul style="list-style-type: none"> <li>• Plug-in module 8AC126.60-1 added:               <ul style="list-style-type: none"> <li>- Order data</li> <li>- Technical data</li> <li>- Pinout</li> </ul> </li> <li>• 0.75 mm<sup>2</sup> motor cables added:               <ul style="list-style-type: none"> <li>- Order data</li> <li>- Technical data</li> </ul> </li> <li>• Dimensioning chapter:               <ul style="list-style-type: none"> <li>- Using a mains choke added</li> <li>- Dimensioning cooling systems updated</li> </ul> </li> </ul>
1.43	26-Mar-11	Changes / New features <ul style="list-style-type: none"> <li>• Safety notices:               <ul style="list-style-type: none"> <li>New section "Specifications for functional safety" added</li> </ul> </li> <li>• Safety technology:               <ul style="list-style-type: none"> <li>Safety functions/parameters modified, proof test interval changed to 20 years</li> </ul> </li> </ul>
1.42	31-Jul-10	Changes / New features <ul style="list-style-type: none"> <li>• Technical data / 8Vxxxx:               <ul style="list-style-type: none"> <li>Heat dissipation values modified</li> </ul> </li> <li>• Wiring / AC121:               <ul style="list-style-type: none"> <li>Input/Output circuit diagram added.</li> </ul> </li> <li>• Plug-in module 8AC125.60-1 added:               <ul style="list-style-type: none"> <li>- Technical data</li> <li>- Wiring</li> </ul> </li> <li>• Indicators:               <ul style="list-style-type: none"> <li>LED status adjusted to firmware &gt; V2.130</li> </ul> </li> <li>• Technical data / 8AC122.60-3:               <ul style="list-style-type: none"> <li>ParIDs for setting the gear ratio added to footnote</li> </ul> </li> </ul>
1.41	31-Oct-08	Start of revision history publication

Table 1: Manual history

## 2 ACOPOS

### 2.1 High-performance servo drive design

The ACOPOS servo drive family is an important component of the complete automation solutions provided by B&R. Industry-specific functions and intuitive tools form the basis for short development times.

An important criteria for the performance of an automation solution is fast and precise reactions to events handled the application or to immediate changes in the production process. Because of this, ACOPOS servo drives work with very short sampling times and communication cycles of 400  $\mu\text{s}$ , which only amount to 50  $\mu\text{s}$  in the control loop.

### 2.2 More room for innovation

The successful application of ACOPOS servo drives in the following fields demonstrates the impressive innovative power of their pioneering design: performance and function coupled with ease of use.

- Packaging industry
- Handling technology
- Plastics processing
- Paper and printing
- Textile industry
- Wood industry
- Metalworking industry
- Semiconductor industry

## 2.3 Maximum safety

The ACOPOS servo family was thoroughly tested during the development phase. Under difficult conditions, such as heavy vibrations or increased temperatures, the devices were subject to loads that greatly exceed the values that occur in normal everyday operation.



Figure 1: EMC testing of ACOPOS servo drives - maximum security for the user

EMC was given special attention to facilitate use in a harsh industrial environments. Field tests have been carried out under difficult conditions in addition to the tests defined in the standard. The results confirm the excellent values measured by the testing laboratory and during operation. The necessary filters, which meet CE guidelines, are also integrated in the device. Using computer-aided models, the thermal behavior of the entire system is pre-calculated based on measured currents and temperatures. This results in maximum performance by taking advantage of the system's full capabilities. ACOPOS servo drives use the information on the motor's embedded parameter chip, which contains all relevant mechanical and electronic data. The work-intensive and error-prone task of manually setting parameters is no longer necessary and start-up times are substantially reduced. During service, relevant data can be requested and the cause of any problems that may exist can be determined.

The ACOPOS servo family is also available with partially-coated circuit boards. These versions are – with identical specifications – more robust in regard to environmental influences such as dust, aggressive vapors or moisture.

## 2.4 Modular and precise with communication options

The I/O channels needed to operate a servo axis are part of the standard equipment for ACOPOS servo drives. The user is provided two trigger inputs for tasks requiring precise measurements or registration mark control.



Figure 2: Plug-in modules allow optimized, application-specific configuration of ACOPOS servo drives

Further configuration of the ACOPOS servo drive to meet the respective application-specific demands takes place using plug-in modules. Plug-in modules are available to establish network connections with other drives, controllers and visualization devices as well as for the connection of encoders, sensors and actuators. Additionally, CPU modules for controller and drive integration are also available for drive-based automation.

### 2.5 Configuring instead of programming

ACOPOS servo drives can be configured for demanding positioning tasks such as electronic gears or cam profiles. Based on long-term cooperation with customers from all over the world, B&R shares its know-how in the form of compact function blocks for many applications. Industry-specific functionality can be quickly and easily implemented in an application program.

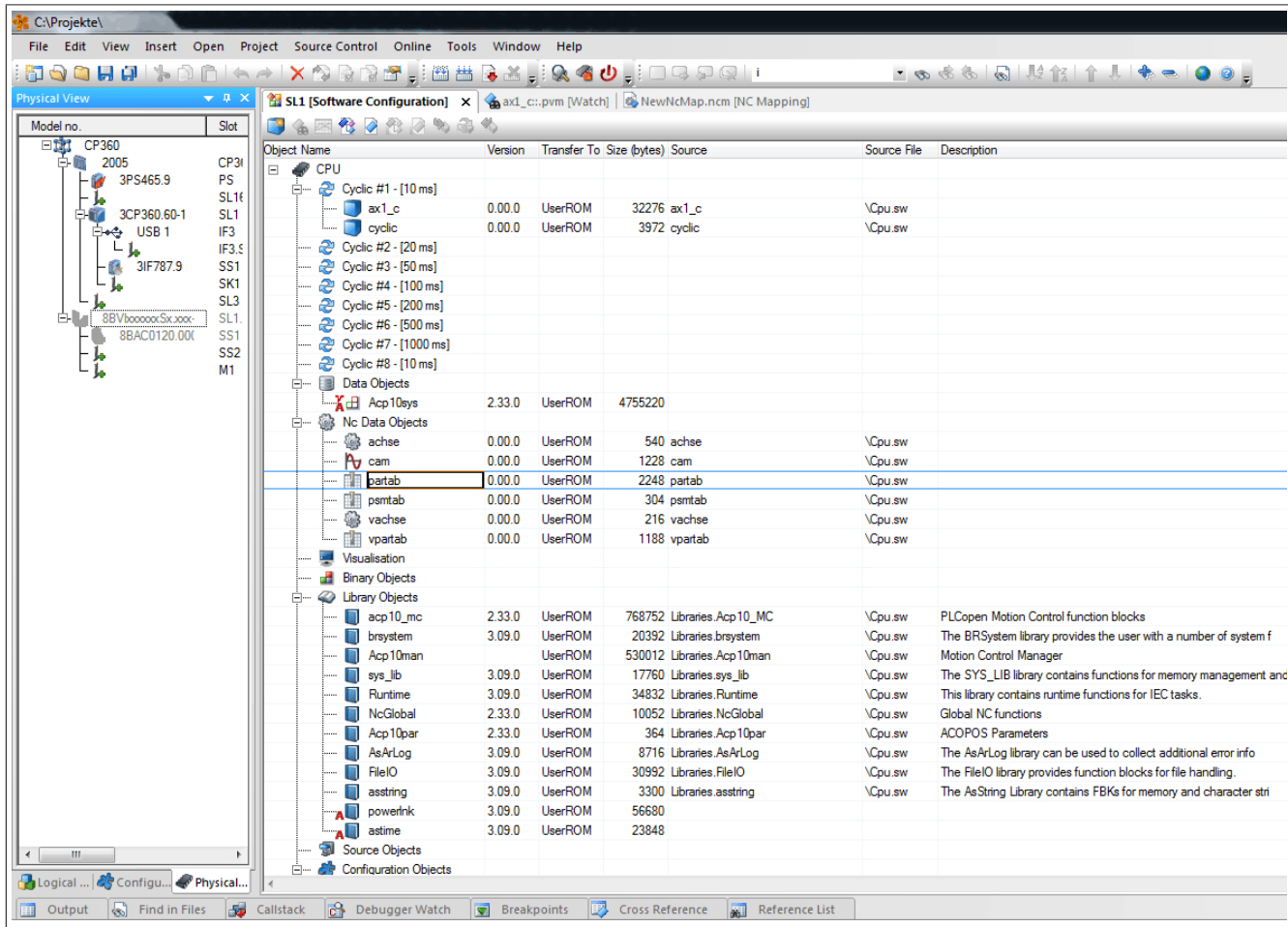


Figure 3: Configuring ACOPOS servo drives using B&R Automation Studio guarantees fast and easy implementation of application requirements

## 2.6 PLCopen motion control function blocks

Motion control is one of the central topics in automation technology. This is due in part to the fact that this area bears a relatively high share of the costs of an entire automation solution. As a result, the potential for savings are high as well.

PLCopen motion control function blocks comply with the IEC 61131-3 standard and support users in this endeavor by offering vendor-independence and reducing overall development times. They provide additional support in that they can be used with a wide variety of programming languages, including Ladder Diagram (LD), Structured Text (ST) and the high-level language C.

The range of functions offered by these blocks are grouped according to single and multi-axis movements. In addition to conventional relative and absolute movements, the first of these two groups also includes the possibility of overlapping movements. With multi-axis movements, functions such as gears, cam profile functions, up/down synchronization and differential gears (changing the phase angle) are also supported.

## 2.7 Higher productivity with Smart Process Technology

Smart Process Technology meets customer needs for cost-effective solutions and high production speeds. This freely configurable technology library is uniformly integrated into existing motion control products.

The use of indirect process parameters makes it possible to eliminate sensors, which are often not fast enough to keep up with high production speeds. Synchronous processing and short response times make it possible to achieve excellent productivity and precision. In addition, powerful and intelligent decentralized units allow seamless quality control. In the field, this significantly reduces cycle times while improving component quality.

As a result, the demands placed on advanced motion control components – high product quality, machine productivity, short maintenance and down times and, increasingly important, seamless quality control during production – are met completely.

## 2.8 ACOPOS – Perfect for CNC applications as well

The integrated SoftCNC system from B&R combines all of the software components necessary for machine automation on a 64-bit processing platform and provides more than enough computing power to handle complex processing machines. Its integrated system architecture, used together with ACOPOS servo drives, opens up many opportunities with regard to response speed, data throughput and precision, all while providing a way to reduce overall costs.

- Uniformly integrated ACOPOS servo drive technology
- Powerful, with fast response times
- Ultimate freedom for automation concepts with unlimited PLC and CNC system flexibility
- 8 independent CNC channels
- Up to a total of 100 axes for positioning, CNC and electronic gears
- Customized graphical interface
- Nearly unlimited system memory for programs, diagnostics and process data
- Internet or intranet connection for inspections or remote maintenance

Leading manufacturers of water jet, laser and flame cutting machines are already utilizing these technological advantages.

## 2.9 Quick and easy commissioning

All B&R products are programmed in the same way using the Windows-based tool B&R Automation Studio. This software allows complex drive solutions to be created after just a short orientation period. Hardware components and program sections can be added and configured in dialog boxes, considerably reducing project development time.

Axis movements can be checked without programming using the NC Test feature. All types of motions, ranging from point-to-point movements to gear functions, can be carried out interactively. The response of an axis can even be monitored while the system is online. In addition, Trace functionality records relevant drive data for clear evaluation at any time.

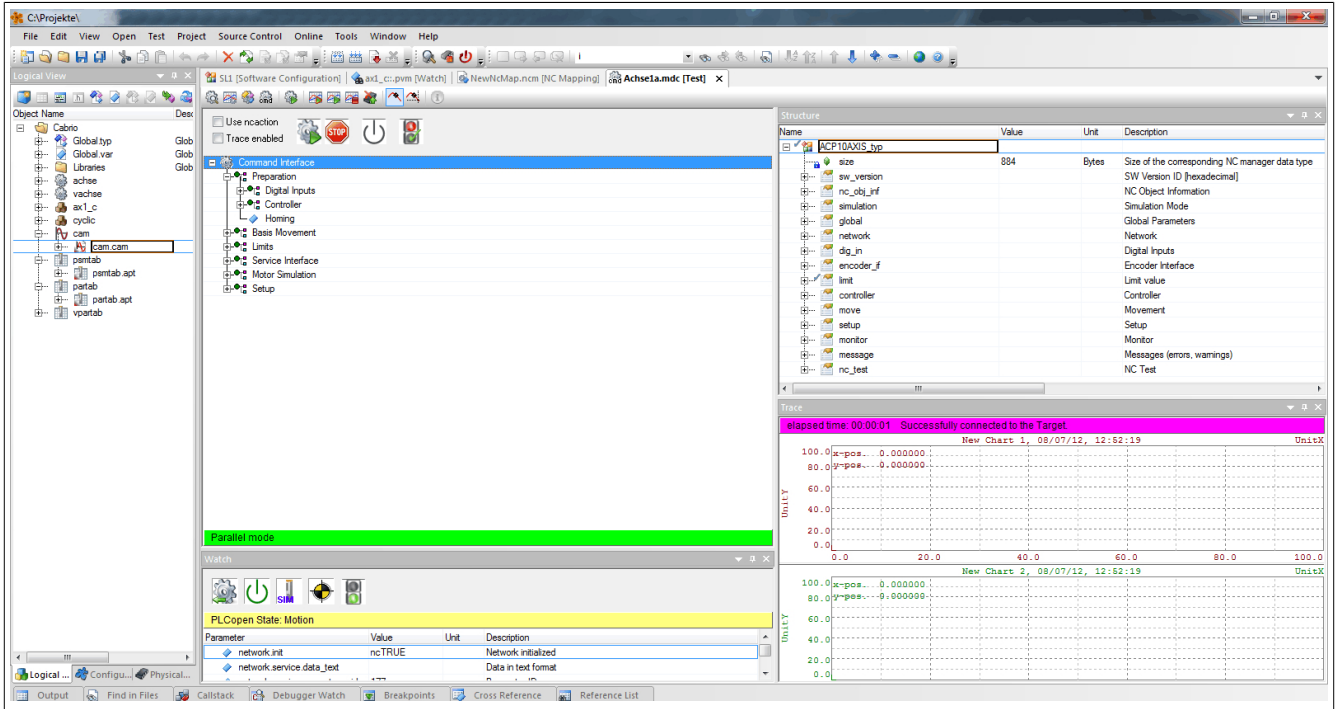


Figure 4: Optimal control of the movement using NC Test and Trace functionality

## 2.10 Tools for straightforward and efficient diagnostics

Drives are monitored in real time using an oscilloscope function, with a wide variety of trigger options able to generate informative data for analyzing movements during operation. A graphic display allows the user to make fine adjustments and optimize movements in the microsecond range. The integration of powerful tools such as the cam editor reduces programming for complex coupled movements to simple drag-and-drop procedures. The results and effects on speed, acceleration and jolt can be immediately analyzed in graphic form.

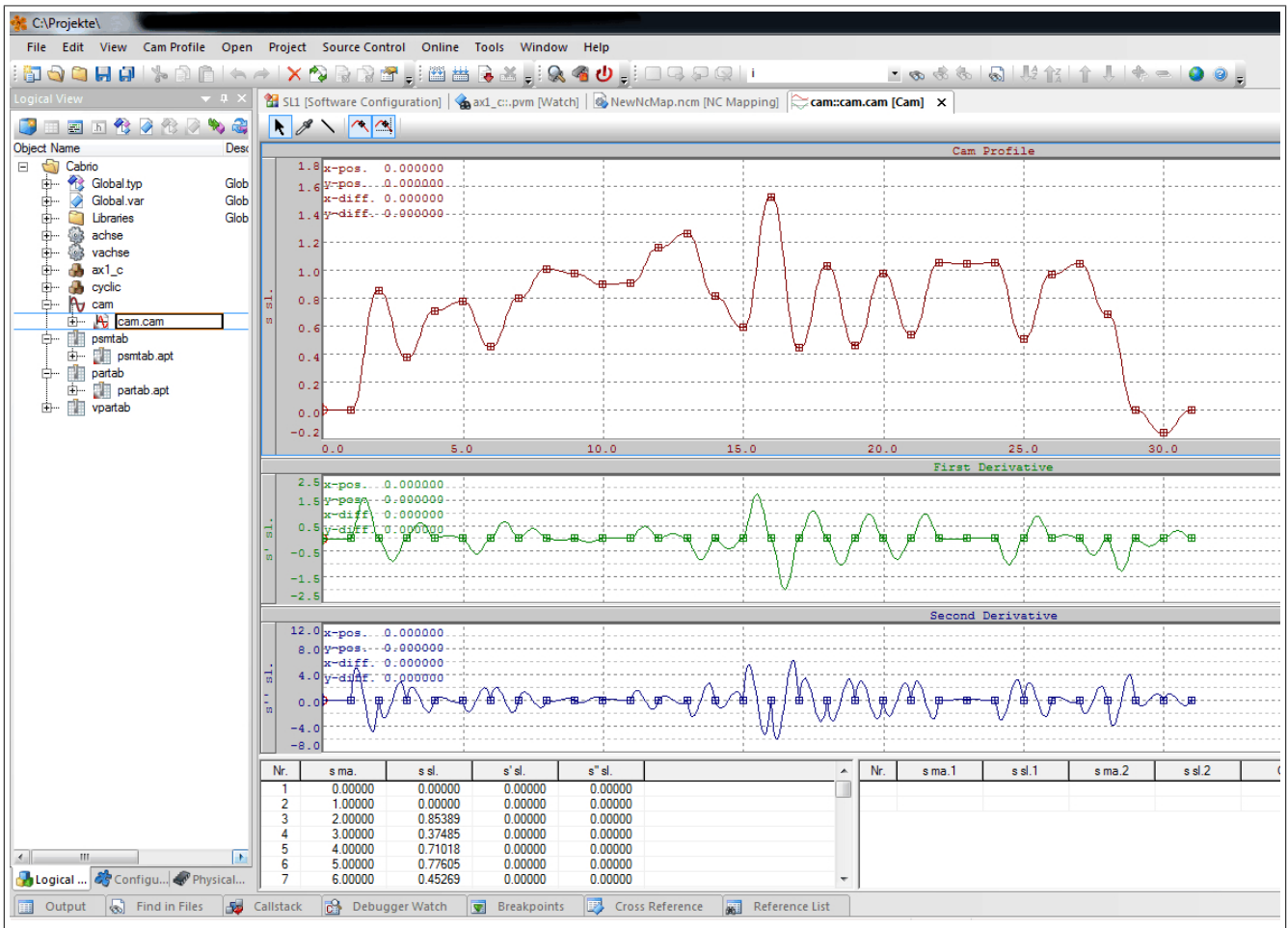


Figure 5: Cam editor - for creating movement profiles simply and precisely

### 3 ACOPOS configurations

ACOPOS servo drives include several technology-specific functions with performance, flexibility and capability in the field which has been remarkably proven in countless applications. The ACOPOS functions listed below are basic functions that the user can switch between as needed within 400  $\mu$ s. In addition, manipulations such as changes in product length, registration mark control, overlying torque control, brief process adaptations and quality checks can be carried out at any time.

- Point-to-point movements
- Electronic gears
- Electronic differential gears
- Cutting units
- Electronic cam profiles
- Flying saws
- Line shafts
- CNC

ACOPOS servo drives can be used in various configurations depending on the network type and the requirements of the application. The functions listed above are available to the user in each of the topology examples shown.

Response speeds are not influenced by the network and control system being used if technology functions are processed directly on the ACOPOS servo drive. Additional sensors and actuators must be integrated in the control system for more complex processes. In these cases, the level of performance depends mostly on the type of network and control system being used.

The topology examples shown on the following pages provide an overview of the bandwidths that are possible with B&R automation components.

#### 3.1 ACOPOS in a POWERLINK network

High-performance machine architectures require flexible networks and fieldbuses. With POWERLINK, a network is available to the user that fully meets the high demands of dynamic motion systems. POWERLINK adapts to the requirements of the machine and the system. The rigid coupling of many axes with controllers, industrial PCs, I/O systems and operator panels allows machines and systems to be created with the highest level of precision. Compatibility to standard Ethernet also reduces the number of networks and fieldbuses on the machine level.

#### Successful areas of use for these topologies:

- Packaging industry
- Handling technology
- Plastics processing
- Paper and printing
- Textile industry
- Wood industry
- Metalworking industry
- Semiconductor industry

### 3.1.1 Recommended topology for POWERLINK networks

In the POWERLINK network (seen from the manager), the tree structure should always come first followed by the line structure. Otherwise, the line structure delay affects the entire tree beneath it.

#### Information:

It should be noted that the longest path is allowed a maximum of 10 hubs by the manager.

#### Information:

Communication to all POWERLINK stations connected to the POWERLINK network in a line-formed network via the mini-hub of this ACOPOS servo drive is interrupted during the network initialization (startup) of an ACOPOS servo drive.

### 3.1.2 Further literature

Unless otherwise stated, the recommendations in the following documents apply:

- "Industrial Ethernet Planning and Installation Guide", Draft 2.0, IAONA ([www.iaona-eu.com](http://www.iaona-eu.com))
- "Guide to Understanding and Obtaining High Quality Generic Cabling", 3P Third Party Testing ([www.3ptest.dk](http://www.3ptest.dk))

## 3.2 Compact, modular motion control applications

All ACOPOS servo drives serve as a mini-hub for cabling and allow line-formed routing of the POWERLINK network. This considerably reduces the cabling expenditure (without reducing functionality).

- Modular machine architectures with up to 100 m between individual axes
- Minimal wiring required due to line structure (no ring)
- No additional infrastructure components needed
- Synchronization from the PLC program to the drive control loop

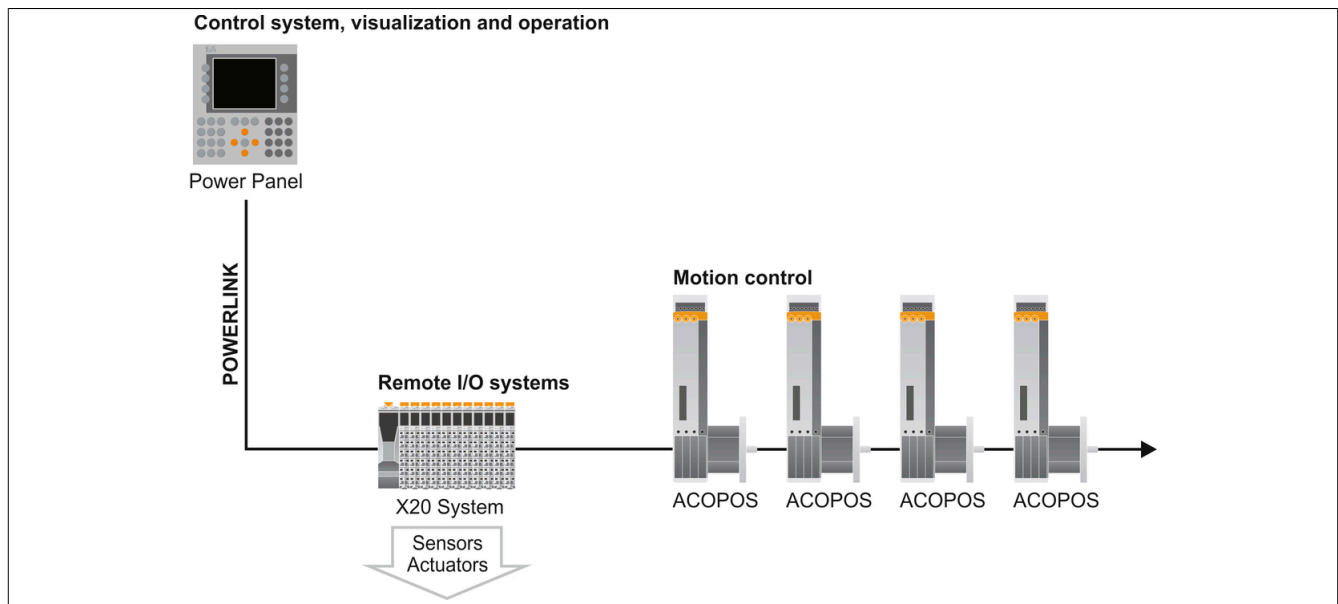


Figure 6: Compact, modular motion control applications

### 3.3 Extensive, modular motion control applications with up to 253 axes

ACOPOS servo drives are connected to the POWERLINK network in star topologies using hubs and line topologies.

- Modular machine architectures with up to 100 m between individual axes
- Optimized wiring using a mixed star/line structure
- Nodes with fast and slow sampling rates operable within a single network, eliminating the need to divide the network into fast and slow segments
- Synchronization from the PLC program to the drive control loop

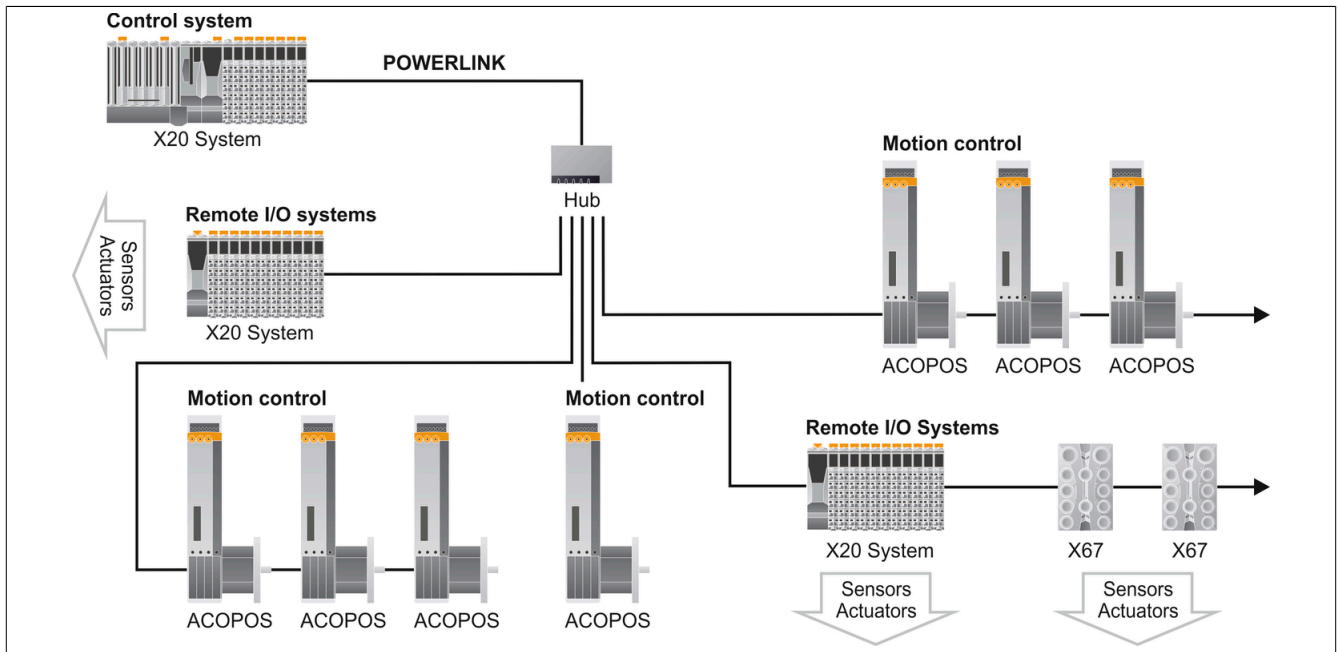


Figure 7: Extensive, modular motion control applications with up to 253 axes

### 3.4 ACOPOS in a CAN bus network

The dynamic requirements for small and mid-sized machines with several axes can be handled efficiently using a CAN bus.

The CAN bus is a cost-effective fieldbus for networking ACOPOS servo drives with controllers, industrial PCs, I/O systems and operator panels.

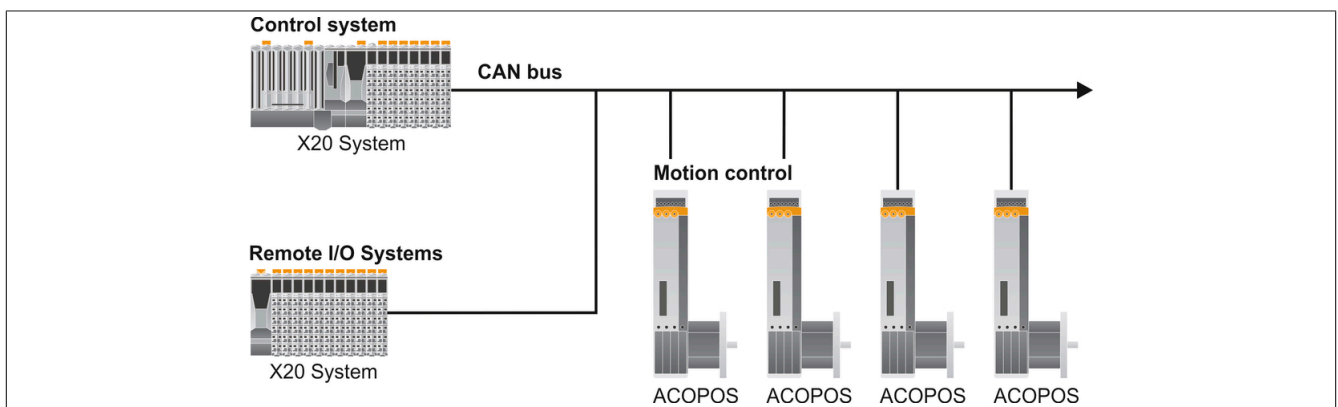


Figure 8: ACOPOS in a CAN bus network

### 3.5 Drive-based control

The controller is located centrally on an ACOPOS servo drive. The drives are networked and synchronized with each other via the CAN bus. As a result, electronic gear and cam profile applications as well as CNC applications are possible in addition to simple point-to-point movements. Powerful operation and visualization is managed by the controller in the ACOPOS servo drive. I/O signals are connected in the control cabinet or directly in the machine room. By eliminating the need for an external controller, even very limited space can be used optimally.

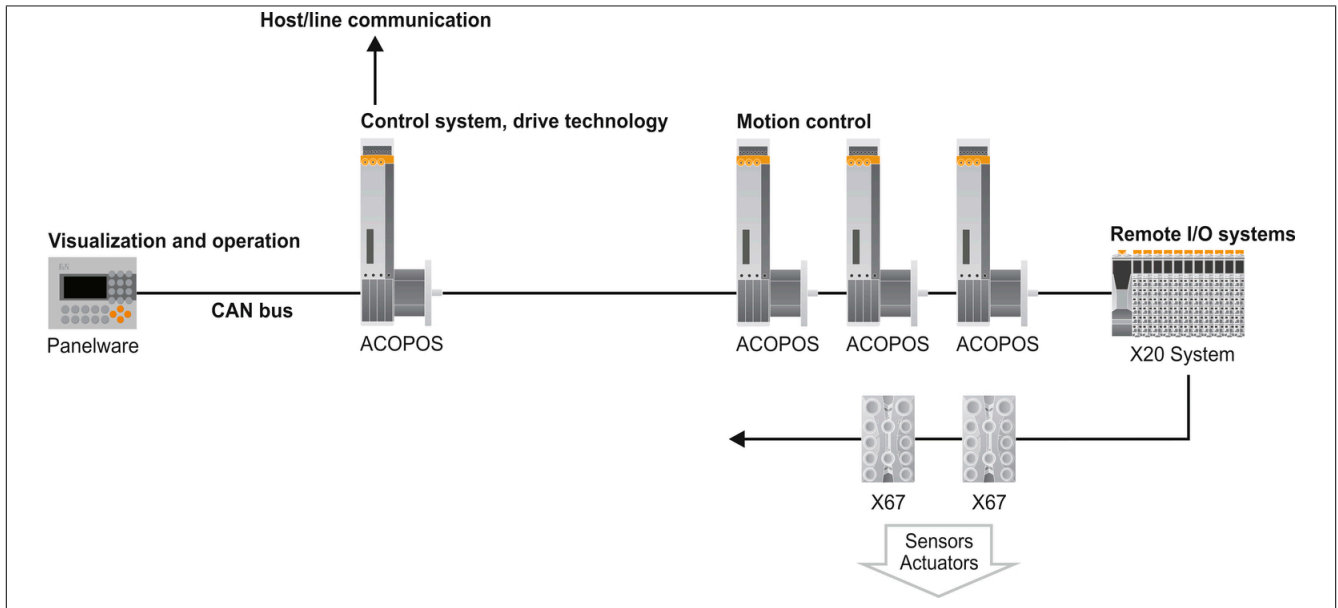


Figure 9: Drive-based automation with ACOPOS

## 4 Safety guidelines

### 4.1 Organization of safety notices

Safety notices in this manual are organized as follows:

Safety notice	Description
<b>Danger!</b>	Disregarding these safety guidelines and notices can be life-threatening.
<b>Warning!</b>	Disregarding these safety guidelines and notices can result in severe injury or substantial damage to equipment.
<b>Caution!</b>	Disregarding these safety guidelines and notices can result in injury or damage to equipment.
<b>Information:</b>	This information is important for preventing errors.

Table 2: Description of the safety notices used in this documentation

### 4.2 General information

B&R servo drives and servo motors have been designed, developed and manufactured for conventional use in industrial environments. They were not designed, developed and manufactured for any use involving serious risks or hazards that could lead to death, injury, serious physical damage or loss of any kind without the implementation of exceptionally stringent safety precautions. In particular, such risks and hazards include the use of these devices to monitor nuclear reactions in nuclear power plants, their use in flight control or flight safety systems as well as in the control of mass transportation systems, medical life support systems or weapons systems.

#### **Danger!**

**Drive systems and motors can have exposed parts that carry voltage (e.g. terminals) as well as hot surfaces. Additional hazards include moving machine parts. Improperly removing required covers, inappropriate use of the devices or their improper installation or operation can result in severe personal injury or damage to property.**

All tasks such as the transport, installation, commissioning and servicing of devices are only permitted to be carried out by qualified personnel. Qualified personnel are those familiar with the transport, mounting, installation, commissioning and operation of devices who also have the appropriate qualifications (e.g. IEC 60364). National accident prevention regulations must be observed.

The safety notices, connection descriptions (type plate and documentation) and limit values listed in the technical data are to be read carefully before installation and commissioning and must be observed.

#### **Danger!**

**The improper handling of servo drives and servo motors can cause severe personal injury or damage to property!**

### 4.3 Intended use

Servo drives are components designed to be installed in electrical systems or machines. They are not permitted to be used unless the machine meets directive 2006/42/EC (machine directive) as well as directive 2004/108/EC (EMC directive).

Servo drives are only permitted to be operated directly on grounded, three-phase industrial mains (TN, TT power mains). When used in residential areas, shops or small businesses, additional measures must be implemented by the user.

#### **Danger!**

**Servo drives are not permitted to be operated directly on IT and TN-S mains with a grounded phase conductor and protective ground conductor!**

Technical data as well as connection and environmental specifications can be found on the type plate and in this user's manual. These specifications regarding connection and environmental conditions must be observed!

#### **Danger!**

**Electronic devices are never completely failsafe. If the servo drive fails, the user is responsible for ensuring that the connected motor is brought to a secure state.**

### 4.4 Protection against electrostatic discharge

Electrical components that can be damaged by electrostatic discharge (ESD) must be handled accordingly.

#### 4.4.1 Packaging

Electrical components with a housing do not require any special ESD packaging, but they must still be handled properly (see section 4.4.2 "Guidelines for proper ESD handling" on page 24).

Electrical components without a housing are protected by ESD protective packaging.

#### 4.4.2 Guidelines for proper ESD handling

##### Electrical components with a housing

- Do not touch the connector contacts on connected cables.
- Do not touch the contact tips on circuit boards.

##### Electrical components without a housing

The following applies in addition to the points listed under "Electrical components with a housing":

- Any persons handling electrical components or devices with installed electrical components must be grounded.
- Components may only be touched on their narrow sides or front plate.
- Components should always be stored in a suitable medium (ESD packaging, conductive foam, etc.).  
Metallic surfaces are not suitable storage surfaces!
- Components should not be subjected to electrostatic discharge (e.g. through the use of charged plastics).
- Ensure a minimum distance of 10 cm from monitors and TV sets.
- Measuring instruments and equipment must be grounded.
- Measurement probes on potential-free measurement devices must be discharged on sufficiently grounded surfaces before taking measurements.

##### Individual components

- ESD protective measures for individual components are thoroughly integrated at B&R (conductive floors, footwear, arm bands, etc.).
- These increased ESD protective measures for individual components are not necessary for customers handling B&R products.

#### 4.5 Transport and storage

During transport and storage, devices must be protected against undue stress (mechanical loads, temperature, humidity, aggressive atmospheres, etc.).

Servo drives contain components sensitive to electrostatic charges that can be damaged by inappropriate handling. It is therefore necessary to provide the required protective measures against electrostatic discharge when installing or removing these servo drives.

## 4.6 Installation

Installation must be performed according to this documentation using suitable equipment and tools.

Devices may only be installed by qualified personnel without voltage applied. Before installation, voltage to the control cabinet must be switched off and prevented from being switched on again.

General safety guidelines and national accident prevention regulations (e.g. VBG 4) for working with high voltage systems must be observed.

Electrical installation must be carried out according to applicable guidelines (e.g. line cross sections, fuses, protective ground connections, see also see "Dimensioning" on page 203).

## 4.7 Operation

### 4.7.1 Protection against touching electrical parts

#### **Danger!**

**To operate servo drives, it is necessary for certain parts to carry dangerous voltages over 42 VDC. Touching one of these parts can result in a life-threatening electric shock. This could lead to death, severe injury or damage to equipment.**

Before turning on a servo drive, it is important to ensure that the housing is properly connected to ground (PE rail). The ground connection must be established even when testing the drive or operating it for a short time!

Before turning the device on, all parts that carry voltage must be securely covered. During operation, all covers and control cabinet doors must remain closed.

#### **Danger!**

**If an application uses the safety functions integrated in the drive system, then the safety functions must be fully validated before being turned on for the first time. This could lead to death, severe injury or damage to equipment.**

Control and power connections can still carry voltage even if the motor is not turning. Touching these connections when the device is switched on is prohibited. Before performing any work on servo drives, they must first be disconnected from the power mains and prevented from being switched on again.

#### **Danger!**

**After switching off the servo drive, wait until the DC bus discharge time of at least five minutes has passed. The voltage currently on the DC bus must be measured between -DC1 and +DC1 with a suitable measuring device before beginning work. This voltage must be less than 42 VDC to rule out danger. An unlit Run LED does not indicate that voltage is not present on the device!**

Servo drives are labeled with the following warning:

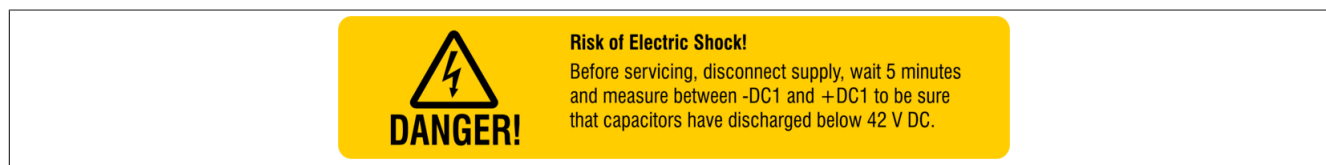


Figure 10: Warning on the servo drive

The connections for servo drive signal voltages ranging from 5 to 30 V are safely isolated circuits. The signal voltage connections and interfaces are therefore only permitted to be connected to devices or electrical components that have sufficient isolation in accordance with IEC 60364-4-41 or EN 61800-5-1 and that correspond to SELV / PELV or a class DVC A safety extra low voltage in accordance with EN 61800-5-1.

Never remove the electrical connections from the servo drive with voltage applied. In some cases, electric arcs may occur that can cause personal injury and/or damage to contacts.

#### 4.7.2 Protection against hazardous movements

### Danger!

Improper control of motors can result in unintended hazardous movements! Such incorrect behavior can have various causes:

- Incorrect installation or a mistake when handling components
- Improper or incomplete wiring
- Defective devices (servo drive, motor, position encoder, cables, brake)
- Incorrect control (e.g. caused by software error)

Some of the errors listed above can be detected and prevented by the servo drive's internal monitoring. Nevertheless, it is still possible for the motor shaft to move any time the device is switched on! For this reason, higher-level safety precautions need to be put in place to ensure that personnel and machines are protected.

The moving parts on machines must be shielded in such a way as to prevent unintentional access by personnel. This type of protection can be achieved by using stable mechanical protective equipment such as protective covers, protective fences, protective gates or light barriers.

Removing, bypassing or circumventing these safety measures and entering the area where movement takes place is prohibited.

A sufficient number of emergency stop switches must be installed in direct proximity to the machine and be easily accessible at all times. This emergency stop equipment must be checked before the machine is commissioned.

On free running motors, the shaft key (if present) must be removed or measures taken to prevent its ejection.

The holding brake built into motors cannot prevent hoisting equipment from dropping hanging loads.

#### 4.7.3 Protection against burns

The surfaces of servo drives and servo motors can reach very high temperatures during operation.

Servo drives are therefore labeled with the following warning:



Figure 11: Warning on the servo drive

#### 4.8 Specifications for functional safety

Specifications for functional safety are listed in the section "Safety technology".

Specifications are calculated based on a proof test interval of up to 20 years. Since a proof test cannot be carried out for B&R drive systems, the proof test interval is the same as the system's mission time.

In accordance with the EN ISO 13849, EN 62061 and IEC 61508 standards, the safety functions described in the "Safety technology" section cannot be used beyond the specified mission time.

### Danger!

The user must ensure that all B&R drive systems that fulfill a safety function are replaced by new B&R drive systems or removed from operation before their mission time expires.

### 4.9 Environmentally friendly disposal

All B&R drive systems and servo motors are designed to inflict as little harm as possible on the environment.

#### 4.9.1 Separation of materials

It is necessary to separate different materials so the device can undergo an environmentally friendly recycling process.

Component	Disposal
Drive systems, servo motors, cables	Electronic recycling
Cardboard box / paper packaging	Paper/cardboard recycling

Table 3: Environmentally friendly separation of materials

Disposal must comply with applicable legal regulations.



# Chapter 2 • Technical data

## 1 Module overview

### ACOPOS 1010, 1016

Product ID	Short description	on page
8V1010.00-2	ACOPOS servo drive, 3x 400-480 V, 1.0 A, 0.45 kW, line filter, integrated braking resistor and electronic secure restart inhibit	35
8V1010.001-2	ACOPOS servo drive, 3x 400-480 V, 1.0 A, 0.45 kW, coated, line filter, integrated braking resistor and electronic secure restart inhibit	35
8V1010.50-2	ACOPOS servo drive, 3x 110-230 V / 1x 110-230 V, 2.3 A, 0.45 kW, line filter, integrated braking resistor and electronic secure restart inhibit	38
8V1010.501-2	ACOPOS servo drive, 3x 110-230 V / 1x 110-230 V, 2.3 A, 0.45 kW, coated, line filter, integrated braking resistor and electronic secure restart inhibit	38
8V1016.00-2	ACOPOS servo drive, 3x 400-480 V, 1.6 A, 0.7 kW, line filter, braking resistor and electronic secure restart inhibit integrated	41
8V1016.001-2	ACOPOS servo drive, 3x 400-480 V, 1.6 A, 0.7 kW, coated, line filter, integrated braking resistor and electronic secure restart inhibit	41
8V1016.50-2	ACOPOS servo drive, 3x 110-230 V / 1x 110-230 V, 3.6 A, 0.7 kW, line filter, integrated braking resistor and electronic secure restart inhibit	45
8V1016.501-2	ACOPOS servo drive, 3x 110-230 V / 1x 110-230 V, 3.6 A, 0.7 kW, coated, line filter, integrated braking resistor and electronic secure restart inhibit	45

### ACOPOS 1022, 1045, 1090

Product ID	Short description	on page
8V1022.00-2	ACOPOS servo drive, 3x 400-480 V, 2.2 A, 1 kW, line filter, integrated braking resistor and electronic secure restart inhibit	56
8V1022.001-2	ACOPOS servo drive, 3x 400-480 V, 2.2 A, 1 kW, coated, line filter, integrated braking resistor and electronic secure restart inhibit	56
8V1045.00-2	ACOPOS servo drive, 3x 400-480 V, 4.4 A, 2 kW, line filter, integrated braking resistor and electronic secure restart inhibit	59
8V1045.001-2	ACOPOS servo drive, 3x 400-480 V, 4.4 A, 2 kW, coated, line filter, integrated braking resistor and electronic secure restart inhibit	59
8V1090.00-2	ACOPOS servo drive, 3x 400-480 V, 8.8 A, 4 kW, line filter, integrated braking resistor and electronic secure restart inhibit	62
8V1090.001-2	ACOPOS servo drive, 3x 400-480 V, 8.8 A, 4 kW, coated, line filter, integrated braking resistor and electronic secure restart inhibit	62

### ACOPOS 1180, 1320

Product ID	Short description	on page
8V1180.00-2	ACOPOS servo drive, 3x 400-480 V, 19 A, 9 kW, line filter, integrated braking resistor, DC bus power supply and electronic secure restart inhibit	72
8V1180.001-2	ACOPOS servo drive, 3x 400-480 V, 19 A, 9 kW, coated, line filter, integrated braking resistor, DC bus power supply and electronic secure restart inhibit	72
8V1320.00-2	ACOPOS servo drive, 3x 400-480 V, 34 A, 16 kW, line filter, integrated braking resistor, DC bus power supply and electronic secure restart inhibit	76
8V1320.001-2	ACOPOS servo drive, 3x 400-480 V, 34 A, 16 kW, coated, line filter, integrated braking resistor, DC bus power supply and electronic secure restart inhibit	76

### ACOPOS 1640, 128M

Product ID	Short description	on page
8V128M.00-2	ACOPOS servo drive, 3x 400-480 V, 128 A, 64 kW, line filter, integrated braking resistor, DC bus power supply and electronic secure restart inhibit	91
8V128M.001-2	ACOPOS servo drive, 3x 400-480 V, 128 A, 64 kW, coated, line filter, integrated braking resistor, DC bus power supply and electronic secure restart inhibit	91
8V1640.00-2	ACOPOS servo drive, 3x 400-480 V, 64 A, 32 kW, line filter, integrated braking resistor, DC bus power supply and electronic secure restart inhibit	87
8V1640.001-2	ACOPOS servo drive, 3x 400-480 V, 64 A, 32 kW, coated, line filter, integrated braking resistor, DC bus power supply and electronic secure restart inhibit	87

### ACOPOS plug-in modules

Product ID	Short description	on page
8AC110.60-2	ACOPOS plug-in module, CAN interface	102
8AC114.60-2	ACOPOS plug-in module, POWERLINK V2 interface	105
8AC120.60-1	ACOPOS plug-in module, EnDat encoder and sine incremental encoder interface	108
8AC121.60-1	ACOPOS plug-in module, HIPERFACE interface	112
8AC122.60-3	ACOPOS plug-in module, resolver interface 10 kHz	115
8AC123.60-1	ACOPOS plug-in module, incremental encoder and SSI absolute encoder interface	118
8AC125.60-1	ACOPOS plug-in module, BiSS encoder interface 5V	122
8AC126.60-1	ACOPOS plug-in module, EnDat 2.2 encoder interface	124

Product ID	Short description	on page
8AC130.60-1	ACOPOS plug-in module, 8 digital I/O configurable in pairs as 24 V input or as output 400/100 mA, 2 digital outputs 2 A, order TB712 terminal block separately.	127
8AC131.60-1	ACOPOS plug-in module, 2 analog inputs $\pm 10$ V, 2 digital I/O configurable as 24 V input or output 45 mA, order TB712 terminal block separately.	131
8AC140.60-3	ACOPOS plug-in module, CPU, x86 100 MHz Intel compatible, 32 MB DRAM, 32 kB SRAM, removable program memory: CompactFlash, 1 CAN interface, 1 Ethernet interface 100 Base-T, 1 PROFIBUS DP Slave interface, 1 RS232 interface, 3 digital I/O configurable as 24 VDC input or output 500 mA, 1 analog input $\pm 10$ V, order program memory and 0TB708 terminal block separately.	135
8AC140.61-3	ACOPOS plug-in module, CPU, ARNC0, x86 100 MHz Intel compatible, 32 MB DRAM, 32 kB SRAM, removable program memory: CompactFlash, 1 CAN interface, 1 Ethernet interface 100 Base-T, 1 PROFIBUS DP Slave interface, 1 RS232 interface, 3 digital I/O configurable as 24 VDC input or output 500 mA, 1 analog input $\pm 10$ V, order program memory and 0TB708 terminal block separately.	136
8AC141.60-2	ACOPOS plug-in module, CPU, x86 100 MHz Intel compatible, 16 MB DRAM, 32 kB SRAM, removable application memory: CompactFlash, 2 CAN interfaces, 1 Ethernet interface 100 Base-T, 1 RS232 interface, 1 X2X Link Master interface, 3 digital I/O can be configured as 24 VDC input or output 500 mA, 1 analog input $\pm 10$ V, order program memory and 0TB704 and 0TB708 terminal blocks separately	146
8AC141.61-3	ACOPOS plug-in module, CPU, ARNC0, x86 100 MHz Intel compatible, 32 MB DRAM, 32 kB SRAM, removable application memory: CompactFlash, 2 CAN interfaces, 1 Ethernet interface 100 Base-T, 1 RS232 interface, 1 X2X Link Master interface, 3 digital I/O can be configured as 24 VDC input or output 500 mA, 1 analog input $\pm 10$ V, order program memory and 0TB704 and 0TB708 terminal blocks separately	146

### 8B0W external braking resistors

Product ID	Short description	on page
8B0W0045H000.000-1	ACOPOS multi braking resistor, 450 W, 50 R, IP20, terminals	157
8B0W0045H000.001-1	ACOPOS multi braking resistor, 450 W, 50 R, IP65, terminals	157
8B0W0079H000.000-1	ACOPOS multi braking resistor, 790 W, 33 R, IP20, terminals	157
8B0W0079H000.001-1	ACOPOS multi braking resistor, 790 W, 33 R, IP65, terminals	157

## 2 ACOPOS servo drives

Controlling your power transmission system with B&R ACOPOS servo drives allows you to fully use the advantages of an optimized system architecture. Applications that require additional positioning tasks such as torque limitation or torque control can be created quickly and elegantly. The flexible system concept for B&R servo drives is made possible by coordinated hardware and software components. You can select the optimal system configuration for your application and increase your competitiveness.

- Perfect integration in all B&R product families
- Object-oriented axis programming minimizes development time and increases reusability
- Integrated technology functions for industry-specific tasks
- Operation of synchronous and induction motors possible
- Current controller scan time up to 50  $\mu$ s
- Reduced commissioning and service times using "embedded motor parameter chip"
- CAN bus and POWERLINK network connection
- Input voltage range from 400 - 480 VAC ( $\pm 10\%$ ) for many areas of use
- Connection possibilities for all standard encoder systems
- Up to two free slots for optional technology modules
- Electronic secure restart inhibit integrated
- Optionally available as version with partially-coated circuit boards – more robust with regard to environmental influences

## 2.1 Overview

The ACOPOS servo drive series covers a current range from 1.0 - 128 A and a power range from 0.5 - 64 kW with 11 devices in 4 groups. The devices in a group are designed using the same basic concept. They offer connection possibilities for all standard encoder systems and modular fieldbus interfaces.

Group	8V1010.xxx-2 8V1010.5xx-2 8V1016.xxx-2 8V1016.5xx-2	8V1022.0xx-2 8V1045.0xx-2 8V1090.0xx-2	8V1180.0xx-2 8V1320.0xx-2	8V1640.0xx-2 8V128M.0xx-2
Power connections	Plug connection	Plug connection	Plug connection	Fixed
Integrated line filter	Yes	Yes	Yes	Yes
Power failure monitoring	Yes	Yes	Yes	Yes
DC bus connection	Yes	Yes	Yes	Yes
24 VDC supply	External <sup>1)</sup>	External <sup>1)</sup>	External or internal via DC bus	External or internal via DC bus
24 VDC output	No	No	24 V / 0.5 A	24 V / 0.5 A
Integrated brake chopper	Yes	Yes	Yes	Yes
Internal braking resistor	Yes	Yes	Yes	Yes <sup>2)</sup>
Connection of external braking resistor possible	No	No	Yes	Yes
Monitored output for motor holding brake	Yes	Yes	Yes	Yes
Monitored input for motor temperature sensor	Yes	Yes	Yes	Yes
Max. number of plug-in modules	3	4	4	4

Table 4: Overview of the ACOPOS servo drive series

- 1) An external DC bus power supply can be used.
- 2) The braking resistor integrated in the ACOPOS servo drives 1640 and 128M is dimensioned so that it is possible to brake to a stop (in a typical drive situation).

ACOPOS servo drives are suitable for both synchronous and induction servo motors and have built-in line filters to meet the limit values for CISPR11, Group 2, Class A.

### Warning!

**ACOPOS servo drives are suitable for power mains which can provide a maximum short circuit current (SCCR) of 10,000 A<sub>eff</sub> at a maximum of 528 V<sub>eff</sub>.**

#### 2.1.1 24 VDC supply during power failures

In order to be able to provide the stop function for Category 1 in accordance with IEC 60204-1 during a power failure, the 24 VDC supply voltage for the servo drives as well as encoders, sensors and the safety circuit must remain active during the entire stopping procedure.

ACOPOS servo drives recognize a power failure and can immediately initiate active braking of the motor. The brake energy generated when braking is returned to the DC bus, and the DC bus power supply can use it to create the 24 VDC supply voltage.

### Danger!

**In some applications, the DC bus is not ready for operation or there is not enough brake energy provided to guarantee that the 24 VDC supply voltage remains active until the system is stopped.**

**Internal DC bus power supplies are not ready for operation during the ACOPOS servo drive switch-on interval; external DC bus power supplies are not ready for operation while booting.**

An external DC bus power supply must be used for ACOPOS servo drives 8V1010 to 8V1090. A DC bus power supply is integrated in ACOPOS servo drives 8V1180 to 8V128M.

ACOPOS servo drives with an integrated DC bus power supply provide the 24 VDC supply for the servo drive and also a 24 VDC output to supply encoders, sensors and the safety circuit. In many cases, it is not necessary to use an uninterruptible power supply (UPS) which is otherwise needed.

## 2.2 Status indicators

ACOPOS servo drives are equipped with three LEDs for direct diagnostics:



Figure 12: ACOPOS servo drives - Status indicators

Labeling	Color	Function	Description	
READY	Green	Ready	Green (lit)	The module is operational and the power stage can be enabled (operating system present and booted, no permanent or temporary errors).
			Green (blinking) <sup>1)</sup>	The module is not ready for operation. <u>Examples:</u> <ul style="list-style-type: none"> <li>No signal on one or both enable inputs</li> <li>DC bus voltage outside the tolerance range</li> <li>Overtemperature on the motor (temperature sensor)</li> <li>Motor feedback not connected or defective</li> <li>Motor temperature sensor not connected or defective</li> <li>Overtemperature on the module (IGBT junction, heat sink, etc.)</li> <li>Disturbance on network</li> </ul>
RUN	Orange	Run	Orange (lit)	The module's power stage is enabled.
ERROR	Red	Error	Red (lit) <sup>1)</sup>	There is a permanent error on the module. <u>Examples:</u> <ul style="list-style-type: none"> <li>Permanent overcurrent</li> <li>Invalid data in EPROM</li> </ul>

Table 5: LED status - ACOPOS servo drives

1) Firmware V2.130 and higher

If no LEDs are lit, the ACOPOS servo drive is not being supplied with 24 VDC.

### **Danger!**

**After switching off the device, wait until the DC bus discharge time of at least five minutes has passed. The voltage currently on the DC bus must be measured with a suitable measuring device before beginning work. This voltage must be less than 42 VDC to rule out danger. An unlit Run LED does not indicate that voltage is not present on the device!**

### 2.2.1 LED status

The following timing is used for the indication diagrams:

Block size: 125 ms

Repeats after: 3000 ms

#### Status changes when booting the operating system loader

Status	LED	Display
1. Boot procedure for base hardware active	Green	[Grid]
	Orange	[Grid]
	Red	[Grid]
2. Configuration of network plug-in module active	Green	[Grid]
	Orange	[Grid]
	Red	[Grid]
3. Waiting for network telegram	Green	[Grid]
	Orange	[Grid]
	Red	[Grid]
4. Network communication active	Green	[Grid]
	Orange	[Grid]
	Red	[Grid]

Table 6: Status changes when booting the operating system loader

#### Error status with reference to the CAN plug-in module AC110

Status	LED	Display
Invalid hardware ID <sup>1)</sup>	Green	[Grid]
	Orange	[Grid]
	Red	[Grid]
Boot error on CAN basic hardware	Green	[Grid]
	Orange	[Grid]
	Red	[Grid]
Bus Off	Green	[Grid]
	Orange	[Grid]
	Red	[Grid]
CAN station number is 0	Green	[Grid]
	Orange	[Grid]
	Red	[Grid]

Table 7: Error status with reference to the CAN plug-in module AC110

- 1) Possible errors:
- ACOPOS servo drive defect
  - Plug-in module defect
  - Plug-in module not inserted correctly in the slot

#### Error status with reference to the POWERLINK V2 plug-in module AC114

Status	LED	Display
Invalid hardware ID <sup>1)</sup>	Green	[Grid]
	Orange	[Grid]
	Red	[Grid]
Boot error on POWERLINK basic hardware	Green	[Grid]
	Orange	[Grid]
	Red	[Grid]
Error when booting the AC114-ARM	Green	[Grid]
	Orange	[Grid]
	Red	[Grid]
POWERLINK station number is 0	Green	[Grid]
	Orange	[Grid]
	Red	[Grid]

Table 8: Error status with reference to the POWERLINK V2 plug-in module AC114

- 1) Possible errors:
- ACOPOS servo drive defect (plug-in module not recognized)
  - Plug-in module defect
  - Plug-in module not inserted correctly in the slot
  - Plug-in module functioning but not automatically recognized by the ACOPOS servo drive (old bootstrap loader)

## 2.3 ACOPOS 1010, 1016

### 2.3.1 ACOPOS 8V1010.0xx-2

#### 2.3.1.1 Order data


Model number	Short description	Figure
<b>Servo drives</b>		
8V1010.00-2	ACOPOS servo drive, 3x 400-480 V, 1.0 A, 0.45 kW, line filter, integrated braking resistor and electronic secure restart inhibit	
8V1010.001-2	ACOPOS servo drive, 3x 400-480 V, 1.0 A, 0.45 kW, coated, line filter, integrated braking resistor and electronic secure restart inhibit	
<b>Optional accessories</b>		
<b>Plug-in modules</b>		
8AC110.60-2	ACOPOS plug-in module, CAN interface	
8AC114.60-2	ACOPOS plug-in module, POWERLINK V2 interface	
8AC120.60-1	ACOPOS plug-in module, EnDat encoder and sine incremental encoder interface	
8AC121.60-1	ACOPOS plug-in module, HIPERFACE interface	
8AC122.60-3	ACOPOS plug-in module, resolver interface 10 kHz	
8AC123.60-1	ACOPOS plug-in module, incremental encoder and SSI absolute encoder interface	
8AC125.60-1	ACOPOS plug-in module, BiSS encoder interface 5 V	
8AC125.60-2	ACOPOS plug-in module, BiSS encoder interface 5V, baud rate 6.25 Mbit/s	
8AC125.61-2	ACOPOS plug-in module, BiSS encoder interface 12V, baud rate 6.25 Mbit/s	
8AC126.60-1	ACOPOS plug-in module, EnDat 2.2 encoder interface	
8AC130.60-1	ACOPOS plug-in module, 8 digital I/O configurable in pairs as 24 V input or as output 400/100 mA, 2 digital outputs 2 A, order TB712 terminal block separately.	
8AC131.60-1	ACOPOS plug-in module, 2 analog inputs $\pm 10$ V, 2 digital I/O points which can be configured as a 24 V input or 45 mA output, order TB712 terminal block separately.	
8AC132.60-1	ACOPOS plug-in module, 2 analog inputs $\pm 10$ V	
8AC140.60-3	ACOPOS plug-in module, CPU, x86 100 MHz Intel compatible, 32 MB DRAM, 32 kB SRAM, removable application memory: CompactFlash, 1 CAN interface, 1 Ethernet interface 100 Base-T, 1 PROFIBUS DP slave interface, 1 RS232 interface, 3 digital I/O can be configured as 24 VDC input or 500 mA output, 1 analog input $\pm 10$ V, order program memory and 0TB708 terminal block separately.	
8AC140.61-3	ACOPOS plug-in module, CPU, ARNC0, x86 100 MHz Intel compatible, 32 MB DRAM, 32 kB SRAM, removable application memory: CompactFlash, 1 CAN interface, 1 Ethernet interface 100 Base-T, 1 PROFIBUS DP slave interface, 1 RS232 interface, 3 digital I/O can be configured as 24 VDC input or 500 mA output, 1 analog input $\pm 10$ V, order program memory and 0TB708 terminal block separately.	
8AC141.60-2	ACOPOS plug-in module, CPU, x86 100 MHz Intel compatible, 16 MB DRAM, 32 kB SRAM, removable application memory: CompactFlash, 2 CAN interfaces, 1 Ethernet interface 100 Base-T, 1 RS232 interface, 1 X2X Link Master interface, 3 digital I/O can be configured as 24 VDC input or output 500 mA, 1 analog input $\pm 10$ V, order program memory and 0TB704 and 0TB708 terminal blocks separately	
8AC141.61-3	ACOPOS plug-in module, CPU, ARNC0, x86 100 MHz Intel compatible, 32 MB DRAM, 32 kB SRAM, removable application memory: CompactFlash, 2 CAN interfaces, 1 Ethernet interface 100 Base-T, 1 RS232 interface, 1 X2X Link Master interface, 3 digital I/O can be configured as 24 VDC input or output 500 mA, 1 analog input $\pm 10$ V, order program memory and 0TB704 and 0TB708 terminal blocks separately	
<b>Shielding component sets</b>		
8X0040.00-1	ACOPOS shielding components set for 8V1010.xxx-x and 8V1016.xxx-x	
<b>Terminal sets</b>		
8X0001.00-1	ACOPOS accessories, plug set for 8V1010.00 and 8V1090.00 (3 phase)	

Table 9: 8V1010.00-2, 8V1010.001-2 - Order data

## 2.3.1.2 Technical data

Product ID	8V1010.00-2	8V1010.001-2
<b>General information</b>		
B&R ID code	0x18D6	0xA6D4
Slots for plug-in modules	3	
Certification c-UL-us	Yes	
<b>Power mains connection</b>		
Permissible power mains forms	TT, TN <sup>1)</sup>	
Mains input voltage	3x 400 VAC to 480 VAC ±10%	
Frequency	50 / 60 Hz ±4%	
Installed load	Max. 1.35 kVA	
Starting current	2 A (at 400 VAC)	
Switch-on interval	>10 s	
Integrated line filter in accordance with EN 61800-3, Category C3 <sup>2)</sup>	Yes	
Power loss at max. device power without braking resistor	80 W	
<b>DC bus connection</b>		
DC bus capacitance	165 µF	
<b>24 VDC supply</b>		
Input voltage <sup>3)</sup>	24 VDC +25% / -20%	
Input capacitance	5600 µF	
Power consumption <sup>4)</sup>	Max. 1.47 A + current for motor holding brake	
<b>Motor connection</b>		
Quantity	1	
Continuous current <sup>5)</sup>	1 A <sub>eff</sub>	
Reduction of continuous current depending on the ambient temperature Mains input voltage: 400 VAC Switching frequency 5 kHz Switching frequency 10 kHz Switching frequency 20 kHz Mains input voltage: 480 VAC Switching frequency 5 kHz Switching frequency 10 kHz Switching frequency 20 kHz	No reduction No reduction <sup>6)</sup> No reduction No reduction No reduction <sup>6)</sup> No reduction 0.13 A <sub>eff</sub> per °C (starting at 45°C)	
Reduction of continuous current depending on the altitude Starting at 500 m above sea level	0.1 A <sub>eff</sub> per 1000 m	
Peak current	2.8 A <sub>eff</sub>	
Nominal switching frequency	10 kHz	
Possible switching frequencies	5 / 10 / 20 kHz	
Electrical stress of the connected motor in accordance with IEC TS 60034-25	Limit value curve A	
Max. motor line length	15 m	
Protective measures Overload protection Short circuit and ground fault protection	Yes Yes	
Max. output frequency	600 Hz <sup>7)</sup>	
<b>Motor holding brake connection</b>		
Max. output current	1.3 A	
Max. number of switching cycles	Unlimited since handled electronically	
<b>Braking resistors</b>		
Peak power output	2 kW	
Continuous power	130 W	
<b>Limit switch and reference inputs</b>		
Quantity	3	
Wiring	Sink	
Electrical isolation Input - ACOPOS Input - Input	Yes No	
Input voltage Nominal Maximum	24 VDC 30 VDC	
Switching threshold Low High	<5 V >15 V	
Input current at nominal voltage	Approx. 4 mA	
Switching delay	Max. 2.0 ms	
Modulation compared to ground potential	Max. ±38 V	
<b>Enable inputs</b>		
Quantity	1	
Wiring	Sink	

Table 10: 8V1010.00-2, 8V1010.001-2 - Technical data

Product ID	8V1010.00-2	8V1010.001-2
Electrical isolation Input - ACOPOS	Yes	
Input voltage Nominal	24 VDC	
Maximum	30 VDC	
Input current at nominal voltage	Approx. 30 mA	
Switching threshold Low	<5 V	
High	>15 V	
Switching delay Enable 0 -> 1, ready for PWM	Max. 100 µs	
Enable 1 -> 0, PWM off	Max. 2.0 ms	
Modulation compared to ground potential	Max. ±38 V	
<b>Trigger inputs</b>		
Quantity	2	
Wiring	Sink	
Electrical isolation Input - ACOPOS	Yes	
Input - Input	No	
Input voltage Nominal	24 VDC	
Maximum	30 VDC	
Switching threshold Low	<5 V	
High	>15 V	
Input current at nominal voltage	Approx. 10 mA	
Switching delay Positive edge	52 µs ±0.5 µs (digitally filtered)	
Negative edge	53 µs ±0.5 µs (digitally filtered)	
Modulation compared to ground potential	Max. ±38 V	
<b>Operating conditions</b>		
Permitted mounting orientations Hanging vertically	Yes	
Lying horizontally	Yes	
Standing horizontally	No	
Installation at altitudes above sea level Nominal	0 to 500 m	
Maximum <sup>8)</sup>	2000 m	
Degree of pollution in accordance with EN 60664-1	2 (non-conductive pollution)	
Overvoltage category in accordance with IEC 60364-4-443:1999	II	
EN 60529 protection	IP20	
<b>Environmental conditions</b>		
Temperature Operation Nominal	5 to 40°C	
Maximum <sup>9)</sup>	55°C	
Storage	-25 to 55°C	
Transport	-25 to 70°C	
Relative humidity Operation	5 to 85%	
Storage	5 to 95%	
Transport	Max. 95% at 40°C	
<b>Mechanical characteristics</b>		
Dimensions Width	58.5 mm	
Height	257 mm	
Depth	220 mm	
Weight	2.5 kg	

Table 10: 8V1010.00-2, 8V1010.001-2 - Technical data

- 1) In the USA, TT and TN power mains are commonly referred to as "Delta/Wye with grounded Wye neutral".
- 2) Limit values from EN 61800-3 C3 (second environment).
- 3) The permissible input voltage range is reduced when using motor holding brakes. The input voltage range should be selected so that the proper supply voltage for the motor holding brake can be maintained.
- 4) The current requirements depend on the configuration of the ACOPOS servo drive.
- 5) Valid in the following conditions: 400 VAC mains input voltage, nominal switching frequency, 40°C ambient temperature, installation altitude <500 m above sea level.
- 6) Value for the nominal switching frequency.
- 7) The module's electrical output frequency (SCTRL\_SPEED\_ACT \* MOTOR\_POLEPAIRS) is monitored to protect against dual use in accordance with EC 428/2009 | 3A225. If the electrical output frequency of the module exceeds the limit value of 600 Hz uninterrupted for more than 0.5 s, then the current movement is aborted and error 6060 is output (power unit: limit speed exceeded).
- 8) Continuous operation of ACOPOS servo drives at altitudes ranging from 500 m to 2000 m above sea level is possible (taking the specified continuous current reductions into consideration). Requirements that go above and beyond this need to be arranged with B&R.
- 9) Continuous operation of ACOPOS servo drives at ambient temperatures ranging from 40°C to max. 55°C is possible (taking the specified continuous current reductions into consideration), but this will result in a shorter service life.

## 2.3.2 ACOPOS 8V1010.5xx-2

### 2.3.2.1 Order data


Model number	Short description	Figure
	<b>Servo drives</b>	
8V1010.50-2	ACOPOS servo drive, 3x 110-230 V / 1x 110-230 V, 2.3 A, 0.45 kW, line filter, integrated braking resistor and electronic secure restart inhibit	
8V1010.501-2	ACOPOS servo drive, 3x 110-230 V / 1x 110-230 V, 2.3 A, 0.45 kW, coated, line filter, integrated braking resistor and electronic secure restart inhibit	
	<b>Optional accessories</b>	
	<b>Plug-in modules</b>	
8AC110.60-2	ACOPOS plug-in module, CAN interface	
8AC114.60-2	ACOPOS plug-in module, POWERLINK V2 interface	
8AC120.60-1	ACOPOS plug-in module, EnDat encoder and sine incremental encoder interface	
8AC121.60-1	ACOPOS plug-in module, HIPERFACE interface	
8AC122.60-3	ACOPOS plug-in module, resolver interface 10 kHz	
8AC123.60-1	ACOPOS plug-in module, incremental encoder and SSI absolute encoder interface	
8AC125.60-1	ACOPOS plug-in module, BiSS encoder interface 5 V	
8AC125.60-2	ACOPOS plug-in module, BiSS encoder interface 5V, baud rate 6.25 Mbit/s	
8AC125.61-2	ACOPOS plug-in module, BiSS encoder interface 12V, baud rate 6.25 Mbit/s	
8AC126.60-1	ACOPOS plug-in module, EnDat 2.2 encoder interface	
8AC130.60-1	ACOPOS plug-in module, 8 digital I/O configurable in pairs as 24 V input or as output 400/100 mA, 2 digital outputs 2 A, order TB712 terminal block separately.	
8AC131.60-1	ACOPOS plug-in module, 2 analog inputs $\pm 10$ V, 2 digital I/O points which can be configured as a 24 V input or 45 mA output, order TB712 terminal block separately.	
8AC132.60-1	ACOPOS plug-in module, 2 analog inputs $\pm 10$ V	
8AC140.60-3	ACOPOS plug-in module, CPU, x86 100 MHz Intel compatible, 32 MB DRAM, 32 kB SRAM, removable application memory: CompactFlash, 1 CAN interface, 1 Ethernet interface 100 Base-T, 1 PROFIBUS DP slave interface, 1 RS232 interface, 3 digital I/O can be configured as 24 VDC input or 500 mA output, 1 analog input $\pm 10$ V, order program memory and 0TB708 terminal block separately.	
8AC140.61-3	ACOPOS plug-in module, CPU, ARNC0, x86 100 MHz Intel compatible, 32 MB DRAM, 32 kB SRAM, removable application memory: CompactFlash, 1 CAN interface, 1 Ethernet interface 100 Base-T, 1 PROFIBUS DP slave interface, 1 RS232 interface, 3 digital I/O can be configured as 24 VDC input or 500 mA output, 1 analog input $\pm 10$ V, order program memory and 0TB708 terminal block separately.	
8AC141.60-2	ACOPOS plug-in module, CPU, x86 100 MHz Intel compatible, 16 MB DRAM, 32 kB SRAM, removable application memory: CompactFlash, 2 CAN interfaces, 1 Ethernet interface 100 Base-T, 1 RS232 interface, 1 X2X Link Master interface, 3 digital I/O can be configured as 24 VDC input or output 500 mA, 1 analog input $\pm 10$ V, order program memory and 0TB704 and 0TB708 terminal blocks separately	
8AC141.61-3	ACOPOS plug-in module, CPU, ARNC0, x86 100 MHz Intel compatible, 32 MB DRAM, 32 kB SRAM, removable application memory: CompactFlash, 2 CAN interfaces, 1 Ethernet interface 100 Base-T, 1 RS232 interface, 1 X2X Link Master interface, 3 digital I/O can be configured as 24 VDC input or output 500 mA, 1 analog input $\pm 10$ V, order program memory and 0TB704 and 0TB708 terminal blocks separately	
	<b>Shielding component sets</b>	
8X0040.00-1	ACOPOS shielding components set for 8V1010.xxx-x and 8V1016.xxx-x	
	<b>Terminal sets</b>	
8X0006.00-1	ACOPOS accessories, plug set for 8V1010.50 and 8V1016.50 (1 phase)	

Table 11: 8V1010.50-2, 8V1010.501-2 - Order data

## 2.3.2.2 Technical data

Product ID	8V1010.50-2	8V1010.501-2
<b>General information</b>		
B&R ID code	0x18D4	0xA6D5
Slots for plug-in modules	3	
Certification c-UL-us	Yes	
<b>Power mains connection</b>		
Permissible power mains forms	TT, TN <sup>1)</sup>	
Mains input voltage	3x 110 VAC to 230 VAC ±10% or 1x 110 VAC to 230 VAC ±10%	
Frequency	50 / 60 Hz ±4%	
Installed load	Max. 1.35 kVA	
Starting current	5 A (at 230 VAC)	
Switch-on interval	>10 s	
Integrated line filter in accordance with EN 61800-3, Category C3 <sup>2)</sup>	Yes	
Power loss at max. device power without braking resistor	80 W	
<b>DC bus connection</b>		
DC bus capacitance	2040 µF	
<b>24 VDC supply</b>		
Input voltage <sup>3)</sup>	24 VDC +25% / -20%	
Input capacitance	5600 µF	
Power consumption <sup>4)</sup>	Max. 1.47 A + current for motor holding brake	
<b>Motor connection</b>		
Quantity	1	
Continuous current <sup>5)</sup>	2.3 A <sub>eff</sub>	
Reduction of continuous current depending on the ambient temperature		
Mains input voltage: 110 VAC		
Switching frequency 5 kHz	No reduction	No reduction
Switching frequency 10 kHz		
Switching frequency 20 kHz		No reduction
Mains input voltage: 230 VAC		
Switching frequency 5 kHz	No reduction	No reduction
Switching frequency 10 kHz		
Switching frequency 20 kHz		No reduction
Reduction of continuous current depending on the altitude		
Starting at 500 m above sea level	0.23 A <sub>eff</sub> per 1000 m	
Peak current	7.8 A <sub>eff</sub>	
Nominal switching frequency	10 kHz	
Possible switching frequencies	5 / 10 / 20 kHz	
Electrical stress of the connected motor in accordance with IEC TS 60034-25	Limit value curve A	
Max. motor line length	15 m	
Protective measures		
Overload protection	Yes	
Short circuit and ground fault protection	Yes	
Max. output frequency	600 Hz <sup>6)</sup>	
<b>Motor holding brake connection</b>		
Max. output current	1.3 A	
Max. number of switching cycles	Unlimited since handled electronically	
<b>Braking resistors</b>		
Peak power output	1.9 kW	
Continuous power	130 W	
<b>Limit switch and reference inputs</b>		
Quantity	3	
Wiring	Sink	
Electrical isolation		
Input - ACOPOS	Yes	
Input - Input	No	
Input voltage		
Nominal	24 VDC	
Maximum	30 VDC	
Switching threshold		
Low	<5 V	
High	>15 V	
Input current at nominal voltage	Approx. 4 mA	
Switching delay	Max. 2.0 ms	
Modulation compared to ground potential	Max. ±38 V	
<b>Enable inputs</b>		
Quantity	1	
Wiring	Sink	

Table 12: 8V1010.50-2, 8V1010.501-2 - Technical data

Product ID	8V1010.50-2	8V1010.501-2
Electrical isolation Input - ACOPOS	Yes	
Input voltage Nominal Maximum	24 VDC 30 VDC	
Input current at nominal voltage	Approx. 30 mA	
Switching threshold Low High	<5 V >15 V	
Switching delay Enable 0 -> 1, ready for PWM Enable 1 -> 0, PWM off	Max. 100 µs Max. 2.0 ms	
Modulation compared to ground potential	Max. ±38 V	
<b>Trigger inputs</b>		
Quantity	2	
Wiring	Sink	
Electrical isolation Input - ACOPOS Input - Input	Yes No	
Input voltage Nominal Maximum	24 VDC 30 VDC	
Switching threshold Low High	<5 V >15 V	
Input current at nominal voltage	Approx. 10 mA	
Switching delay Positive edge Negative edge	52 µs ±0.5 µs (digitally filtered) 53 µs ±0.5 µs (digitally filtered)	
Modulation compared to ground potential	Max. ±38 V	
<b>Operating conditions</b>		
Permitted mounting orientations Hanging vertically Lying horizontally Standing horizontally	Yes Yes No	
Installation at altitudes above sea level Nominal Maximum <sup>7)</sup>	0 to 500 m 2000 m	
Degree of pollution in accordance with EN 60664-1	2 (non-conductive pollution)	
Overvoltage category in accordance with IEC 60364-4-443:1999	II	
EN 60529 protection	IP20	
<b>Environmental conditions</b>		
Temperature Operation Nominal Maximum <sup>8)</sup> Storage Transport	5 to 40°C 55°C -25 to 55°C -25 to 70°C	
Relative humidity Operation Storage Transport	5 to 85% 5 to 95% Max. 95% at 40°C	
<b>Mechanical characteristics</b>		
Dimensions Width Height Depth	58.5 mm 257 mm 220 mm	
Weight	2.5 kg	

Table 12: 8V1010.50-2, 8V1010.501-2 - Technical data

- 1) In the USA, TT and TN power mains are commonly referred to as "Delta/Wye with grounded Wye neutral".
- 2) Limit values from EN 61800-3 C3 (second environment).
- 3) The permissible input voltage range is reduced when using motor holding brakes. The input voltage range should be selected so that the proper supply voltage for the motor holding brake can be maintained.
- 4) The current requirements depend on the configuration of the ACOPOS servo drive.
- 5) Valid in the following conditions: 230 VAC mains input voltage, nominal switching frequency, 40°C ambient temperature, installation altitude <500 m above sea level.
- 6) The module's electrical output frequency (SCTRL\_SPEED\_ACT \* MOTOR\_POLEPAIRS) is monitored to protect against dual use in accordance with EC 428/2009 | 3A225. If the electrical output frequency of the module exceeds the limit value of 600 Hz uninterrupted for more than 0.5 s, then the current movement is aborted and error 6060 is output (power unit: limit speed exceeded).
- 7) Continuous operation of ACOPOS servo drives at altitudes ranging from 500 m to 2000 m above sea level is possible (taking the specified continuous current reductions into consideration). Requirements that go above and beyond this need to be arranged with B&R.
- 8) Continuous operation of ACOPOS servo drives at ambient temperatures ranging from 40°C to max. 55°C is possible (taking the specified continuous current reductions into consideration), but this will result in a shorter service life.
- 9) Value for the nominal switching frequency.

## 2.3.3 ACOPOS 8V1016.0xx-2

### 2.3.3.1 Order data


Model number	Short description	Figure
	<b>Servo drives</b>	
8V1016.00-2	ACOPOS servo drive, 3x 400-480 V, 1.6 A, 0.7 kW, line filter, braking resistor and electronic secure restart inhibit integrated	
8V1016.001-2	ACOPOS servo drive, 3x 400-480 V, 1.6 A, 0.7 kW, coated, line filter, integrated braking resistor and electronic secure restart inhibit	
	<b>Optional accessories</b>	
	<b>Plug-in modules</b>	
8AC110.60-2	ACOPOS plug-in module, CAN interface	
8AC114.60-2	ACOPOS plug-in module, POWERLINK V2 interface	
8AC120.60-1	ACOPOS plug-in module, EnDat encoder and sine incremental encoder interface	
8AC121.60-1	ACOPOS plug-in module, HIPERFACE interface	
8AC122.60-3	ACOPOS plug-in module, resolver interface 10 kHz	
8AC123.60-1	ACOPOS plug-in module, incremental encoder and SSI absolute encoder interface	
8AC125.60-1	ACOPOS plug-in module, BiSS encoder interface 5 V	
8AC125.60-2	ACOPOS plug-in module, BiSS encoder interface 5V, baud rate 6.25 Mbit/s	
8AC125.61-2	ACOPOS plug-in module, BiSS encoder interface 12V, baud rate 6.25 Mbit/s	
8AC126.60-1	ACOPOS plug-in module, EnDat 2.2 encoder interface	
8AC130.60-1	ACOPOS plug-in module, 8 digital I/O configurable in pairs as 24 V input or as output 400/100 mA, 2 digital outputs 2 A, order TB712 terminal block separately.	
8AC131.60-1	ACOPOS plug-in module, 2 analog inputs ±10 V, 2 digital I/O points which can be configured as a 24 V input or 45 mA output, order TB712 terminal block separately.	
8AC132.60-1	ACOPOS plug-in module, 2 analog inputs ±10 V	
8AC140.60-3	ACOPOS plug-in module, CPU, x86 100 MHz Intel compatible, 32 MB DRAM, 32 kB SRAM, removable application memory: CompactFlash, 1 CAN interface, 1 Ethernet interface 100 Base-T, 1 PROFIBUS DP slave interface, 1 RS232 interface, 3 digital I/O can be configured as 24 VDC input or 500 mA output, 1 analog input ±10 V, order program memory and 0TB708 terminal block separately.	
8AC140.61-3	ACOPOS plug-in module, CPU, ARNC0, x86 100 MHz Intel compatible, 32 MB DRAM, 32 kB SRAM, removable application memory: CompactFlash, 1 CAN interface, 1 Ethernet interface 100 Base-T, 1 PROFIBUS DP slave interface, 1 RS232 interface, 3 digital I/O can be configured as 24 VDC input or 500 mA output, 1 analog input ±10 V, order program memory and 0TB708 terminal block separately.	
8AC141.60-2	ACOPOS plug-in module, CPU, x86 100 MHz Intel compatible, 16 MB DRAM, 32 kB SRAM, removable application memory: CompactFlash, 2 CAN interfaces, 1 Ethernet interface 100 Base-T, 1 RS232 interface, 1 X2X Link Master interface, 3 digital I/O can be configured as 24 VDC input or output 500 mA, 1 analog input ±10 V, order program memory and 0TB704 and 0TB708 terminal blocks separately	
8AC141.61-3	ACOPOS plug-in module, CPU, ARNC0, x86 100 MHz Intel compatible, 32 MB DRAM, 32 kB SRAM, removable application memory: CompactFlash, 2 CAN interfaces, 1 Ethernet interface 100 Base-T, 1 RS232 interface, 1 X2X Link Master interface, 3 digital I/O can be configured as 24 VDC input or output 500 mA, 1 analog input ±10 V, order program memory and 0TB704 and 0TB708 terminal blocks separately	
	<b>Shielding component sets</b>	
8X0040.00-1	ACOPOS shielding components set for 8V1010.xxx-x and 8V1016.xxx-x	
	<b>Terminal sets</b>	
8X0001.00-1	ACOPOS accessories, plug set for 8V1010.00 and 8V1090.00 (3 phase)	

Table 13: 8V1016.00-2, 8V1016.001-2 - Order data

## 2.3.3.2 Technical data

Product ID	8V1016.00-2	8V1016.001-2
<b>General information</b>		
B&R ID code	0x18D5	0xA6D6
Slots for plug-in modules	3	
Certification c-UL-us	Yes	
<b>Power mains connection</b>		
Permissible power mains forms	TT, TN <sup>1)</sup>	TT, TN <sup>10)</sup>
Mains input voltage	3x 400 VAC to 480 VAC ±10%	
Frequency	50 / 60 Hz ±4%	
Installed load	Max. 2.1 kVA	
Starting current	2 A (at 400 VAC)	
Switch-on interval	>10 s	
Integrated line filter in accordance with EN 61800-3, Category C3 <sup>2)</sup>	Yes	
Power loss at max. device power without braking resistor	110 W	
<b>DC bus connection</b>		
DC bus capacitance	165 µF	
<b>24 VDC supply</b>		
Input voltage <sup>3)</sup>	24 VDC +25% / -20%	
Input capacitance	5600 µF	
Power consumption <sup>4)</sup>	Max. 1.47 A + current for motor holding brake	
<b>Motor connection</b>		
Quantity	1	
Continuous current <sup>5)</sup>	1.6 A <sub>eff</sub>	
Reduction of continuous current depending on the ambient temperature Mains input voltage: 400 VAC Switching frequency 5 kHz Switching frequency 10 kHz Switching frequency 20 kHz Mains input voltage: 480 VAC Switching frequency 5 kHz Switching frequency 10 kHz Switching frequency 20 kHz	No reduction No reduction <sup>6)</sup> No reduction No reduction No reduction <sup>6)</sup> 0.13 A <sub>eff</sub> per °C (starting at 40°C)	
Reduction of continuous current depending on the altitude Starting at 500 m above sea level	0.16 A <sub>eff</sub> per 1000 m	
Peak current	5 A <sub>eff</sub>	
Nominal switching frequency	10 kHz	
Possible switching frequencies	5 / 10 / 20 kHz	
Electrical stress of the connected motor in accordance with IEC TS 60034-25	Limit value curve A	
Max. motor line length	15 m	
Protective measures Overload protection Short circuit and ground fault protection	Yes Yes	
Max. output frequency	600 Hz <sup>7)</sup>	600 Hz <sup>11)</sup>
<b>Motor holding brake connection</b>		
Max. output current	1.3 A	
Max. number of switching cycles	Unlimited since done electronically	Unlimited since handled electronically
<b>Braking resistors</b>		
Peak power output	2 kW	
Continuous power	130 W	
<b>Limit switch and reference inputs</b>		
Quantity	3	
Wiring	Sink	
Electrical isolation Input - ACOPOS Input - Input	Yes No	
Input voltage Nominal Maximum	24 VDC 30 VDC	
Switching threshold Low High	<5 V >15 V	
Input current at nominal voltage	Approx. 4 mA	
Switching delay	Max. 2.0 ms	
Modulation compared to ground potential	Max. ±38 V	
<b>Enable inputs</b>		
Quantity	1	
Wiring	Sink	

Table 14: 8V1016.00-2, 8V1016.001-2 - Technical data

Product ID	8V1016.00-2	8V1016.001-2
Electrical isolation Input - ACOPOS	Yes	
Input voltage Nominal Maximum	24 VDC 30 VDC	
Input current at nominal voltage	Approx. 30 mA	
Switching threshold Low High	<5 V >15 V	
Switching delay Enable 0 -> 1, ready for PWM Enable 1 -> 0, PWM off	Max. 100 µs Max. 2.0 ms	
Modulation compared to ground potential	Max. ±38 V	
<b>Trigger inputs</b>		
Quantity	2	
Wiring	Sink	
Electrical isolation Input - ACOPOS Input - Input	Yes No	
Input voltage Nominal Maximum	24 VDC 30 VDC	
Switching threshold Low High	<5 V >15 V	
Input current at nominal voltage	Approx. 10 mA	
Switching delay Positive edge Negative edge	52 µs ±0.5 µs (digitally filtered) 53 µs ±0.5 µs (digitally filtered)	
Modulation compared to ground potential	Max. ±38 V	
<b>Operating conditions</b>		
Permitted mounting orientations Hanging vertically Lying horizontally Standing horizontally	Yes Yes No	
Installation at altitudes above sea level Nominal Maximum <sup>8)</sup>	0 to 500 m 2000 m	
Degree of pollution in accordance with EN 60664-1	2 (non-conductive pollution)	
Overvoltage category in accordance with IEC 60364-4-443:1999	II	
EN 60529 protection	IP20	
<b>Environmental conditions</b>		
Temperature Operation Nominal Maximum <sup>9)</sup> Storage Transport	5 to 40°C 55°C -25 to 55°C -25 to 70°C	
Relative humidity Operation Storage Transport	5 to 85% 5 to 95% Max. 95% at 40°C	
<b>Mechanical characteristics</b>		
Dimensions Width Height Depth	58.5 mm 257 mm 220 mm	
Weight	2.5 kg	

Table 14: 8V1016.00-2, 8V1016.001-2 - Technical data

- 1) In the USA, the terms "Delta / Wye with Grounded Wye neutral" are common for TT and TN power mains.
- 2) Limit values from EN 61800-3 C3 (second environment).
- 3) When using motor holding brakes, the valid input voltage range is reduced. The input voltage range should be selected so that the proper supply voltage for the motor holding brake can be maintained.
- 4) The current requirements depend on the configuration of the ACOPOS servo drive.
- 5) Valid in the following conditions: Mains input voltage 400 VAC, nominal switching frequency, 40°C ambient temperature, installation altitudes <500 m above sea level.
- 6) Value for the nominal switching frequency.
- 7) The module's electrical output frequency (SCTRL\_SPEED\_ACT \* MOTOR\_POLEPAIRS) is monitored to protect against dual-use in accordance with EC 428/2009 | 3A225. If the electrical output frequency of the module exceeds the limit value of 600 Hz uninterrupted for more than 0.5 s, then the current motion is aborted and error 6060 is output (Power element: Limit speed exceeded).
- 8) Continuous operation of ACOPOS servo drives at altitudes ranging from 500 m to 2000 m above sea level is possible (taking the continuous current reductions listed into consideration). Requirements that go above and beyond this need to be arranged with B&R.
- 9) Continuous operation of ACOPOS servo drives at ambient temperatures ranging from 40°C to max. 55°C is possible (taking the specified continuous current reductions into consideration), but this will result in a shorter service life.
- 10) In the USA, TT and TN power mains are commonly referred to as "Delta/Wye with grounded Wye neutral".

- 11) The module's electrical output frequency ( $\text{SCTRL\_SPEED\_ACT} * \text{MOTOR\_POLEPAIRS}$ ) is monitored to protect against dual use in accordance with EC 428/2009 | 3A225. If the electrical output frequency of the module exceeds the limit value of 600 Hz uninterrupted for more than 0.5 s, then the current movement is aborted and error 6060 is output (power unit: limit speed exceeded).

## 2.3.4 ACOPOS 8V1016.5xx-2

### 2.3.4.1 Order data


Model number	Short description	Figure
	<b>Servo drives</b>	
8V1016.50-2	ACOPOS servo drive, 3x 110-230 V / 1x 110-230 V, 3.6 A, 0.7 kW, line filter, integrated braking resistor and electronic secure restart inhibit	
8V1016.501-2	ACOPOS servo drive, 3x 110-230 V / 1x 110-230 V, 3.6 A, 0.7 kW, coated, line filter, integrated braking resistor and electronic secure restart inhibit	
	<b>Optional accessories</b>	
	<b>Plug-in modules</b>	
8AC110.60-2	ACOPOS plug-in module, CAN interface	
8AC114.60-2	ACOPOS plug-in module, POWERLINK V2 interface	
8AC120.60-1	ACOPOS plug-in module, EnDat encoder and sine incremental encoder interface	
8AC121.60-1	ACOPOS plug-in module, HIPERFACE interface	
8AC122.60-3	ACOPOS plug-in module, resolver interface 10 kHz	
8AC123.60-1	ACOPOS plug-in module, incremental encoder and SSI absolute encoder interface	
8AC125.60-1	ACOPOS plug-in module, BiSS encoder interface 5 V	
8AC125.60-2	ACOPOS plug-in module, BiSS encoder interface 5V, baud rate 6.25 Mbit/s	
8AC125.61-2	ACOPOS plug-in module, BiSS encoder interface 12V, baud rate 6.25 Mbit/s	
8AC126.60-1	ACOPOS plug-in module, EnDat 2.2 encoder interface	
8AC130.60-1	ACOPOS plug-in module, 8 digital I/O configurable in pairs as 24 V input or as output 400/100 mA, 2 digital outputs 2 A, order TB712 terminal block separately.	
8AC131.60-1	ACOPOS plug-in module, 2 analog inputs $\pm 10$ V, 2 digital I/O points which can be configured as a 24 V input or 45 mA output, order TB712 terminal block separately.	
8AC132.60-1	ACOPOS plug-in module, 2 analog inputs $\pm 10$ V	
8AC140.60-3	ACOPOS plug-in module, CPU, x86 100 MHz Intel compatible, 32 MB DRAM, 32 kB SRAM, removable application memory: CompactFlash, 1 CAN interface, 1 Ethernet interface 100 Base-T, 1 PROFIBUS DP slave interface, 1 RS232 interface, 3 digital I/O can be configured as 24 VDC input or 500 mA output, 1 analog input $\pm 10$ V, order program memory and 0TB708 terminal block separately.	
8AC140.61-3	ACOPOS plug-in module, CPU, ARNC0, x86 100 MHz Intel compatible, 32 MB DRAM, 32 kB SRAM, removable application memory: CompactFlash, 1 CAN interface, 1 Ethernet interface 100 Base-T, 1 PROFIBUS DP slave interface, 1 RS232 interface, 3 digital I/O can be configured as 24 VDC input or 500 mA output, 1 analog input $\pm 10$ V, order program memory and 0TB708 terminal block separately.	
8AC141.60-2	ACOPOS plug-in module, CPU, x86 100 MHz Intel compatible, 16 MB DRAM, 32 kB SRAM, removable application memory: CompactFlash, 2 CAN interfaces, 1 Ethernet interface 100 Base-T, 1 RS232 interface, 1 X2X Link Master interface, 3 digital I/O can be configured as 24 VDC input or output 500 mA, 1 analog input $\pm 10$ V, order program memory and 0TB704 and 0TB708 terminal blocks separately	
8AC141.61-3	ACOPOS plug-in module, CPU, ARNC0, x86 100 MHz Intel compatible, 32 MB DRAM, 32 kB SRAM, removable application memory: CompactFlash, 2 CAN interfaces, 1 Ethernet interface 100 Base-T, 1 RS232 interface, 1 X2X Link Master interface, 3 digital I/O can be configured as 24 VDC input or output 500 mA, 1 analog input $\pm 10$ V, order program memory and 0TB704 and 0TB708 terminal blocks separately	
	<b>Shielding component sets</b>	
8X0040.00-1	ACOPOS shielding components set for 8V1010.xxx-x and 8V1016.xxx-x	
	<b>Terminal sets</b>	
8X0006.00-1	ACOPOS accessories, plug set for 8V1010.50 and 8V1016.50 (1 phase)	

Table 15: 8V1016.50-2, 8V1016.501-2 - Order data

## 2.3.4.2 Technical data

Product ID	8V1016.50-2	8V1016.501-2
<b>General information</b>		
B&R ID code	0x18D7	0xA6D7
Slots for plug-in modules	3	
Certification c-UL-us	Yes	
<b>Power mains connection</b>		
Permissible power mains forms	TT, TN <sup>1)</sup>	
Mains input voltage	3x 110 VAC to 230 VAC ±10% or 1x 110 VAC to 230 VAC ±10%	
Frequency	50 / 60 Hz ±4%	
Installed load	Max. 2.1 kVA	
Starting current	5 A (at 230 VAC)	
Switch-on interval	>10 s	
Integrated line filter in accordance with EN 61800-3, Category C3 <sup>2)</sup>	Yes	
Power loss at max. device power without braking resistor	110 W	
<b>DC bus connection</b>		
DC bus capacitance	2040 µF	
<b>24 VDC supply</b>		
Input voltage <sup>3)</sup>	24 VDC +25% / -20%	
Input capacitance	5600 µF	
Power consumption <sup>4)</sup>	Max. 1.47 A + current for motor holding brake	
<b>Motor connection</b>		
Quantity	1	
Continuous current <sup>5)</sup>	3.6 A <sub>eff</sub>	
Reduction of continuous current depending on the ambient temperature		
Mains input voltage: 110 VAC		
Switching frequency 5 kHz	No reduction	
Switching frequency 10 kHz	No reduction <sup>6)</sup>	
Switching frequency 20 kHz	No reduction	
Mains input voltage: 230 VAC		
Switching frequency 5 kHz	No reduction	
Switching frequency 10 kHz	No reduction <sup>6)</sup>	
Switching frequency 20 kHz	No reduction	
Reduction of continuous current depending on the altitude		
Starting at 500 m above sea level	0.36 A <sub>eff</sub> per 1000 m	
Peak current	12 A <sub>eff</sub>	
Nominal switching frequency	10 kHz	
Possible switching frequencies	5 / 10 / 20 kHz	
Electrical stress of the connected motor in accordance with IEC TS 60034-25	Limit value curve A	
Max. motor line length	15 m	
Protective measures		
Overload protection	Yes	
Short circuit and ground fault protection	Yes	
Max. output frequency	600 Hz <sup>7)</sup>	
<b>Motor holding brake connection</b>		
Max. output current	1.3 A	
Max. number of switching cycles	Unlimited since handled electronically	
<b>Braking resistors</b>		
Peak power output	1.9 kW	
Continuous power	130 W	
<b>Limit switch and reference inputs</b>		
Quantity	3	
Wiring	Sink	
Electrical isolation		
Input - ACOPOS	Yes	
Input - Input	No	
Input voltage		
Nominal	24 VDC	
Maximum	30 VDC	
Switching threshold		
Low	<5 V	
High	>15 V	
Input current at nominal voltage	Approx. 4 mA	
Switching delay	Max. 2.0 ms	
Modulation compared to ground potential	Max. ±38 V	
<b>Enable inputs</b>		
Quantity	1	
Wiring	Sink	

Table 16: 8V1016.50-2, 8V1016.501-2 - Technical data

Product ID	8V1016.50-2	8V1016.501-2
Electrical isolation Input - ACOPOS	Yes	
Input voltage Nominal	24 VDC	
Maximum	30 VDC	
Input current at nominal voltage	Approx. 30 mA	
Switching threshold Low	<5 V	
High	>15 V	
Switching delay Enable 0 -> 1, ready for PWM	Max. 100 µs	
Enable 1 -> 0, PWM off	Max. 2.0 ms	
Modulation compared to ground potential	Max. ±38 V	
<b>Trigger inputs</b>		
Quantity	2	
Wiring	Sink	
Electrical isolation Input - ACOPOS	Yes	
Input - Input	No	
Input voltage Nominal	24 VDC	
Maximum	30 VDC	
Switching threshold Low	<5 V	
High	>15 V	
Input current at nominal voltage	Approx. 10 mA	
Switching delay Positive edge	52 µs ±0.5 µs (digitally filtered)	
Negative edge	53 µs ±0.5 µs (digitally filtered)	
Modulation compared to ground potential	Max. ±38 V	
<b>Operating conditions</b>		
Permitted mounting orientations Hanging vertically	Yes	
Lying horizontally	Yes	
Standing horizontally	No	
Installation at altitudes above sea level Nominal	0 to 500 m	
Maximum <sup>8)</sup>	2000 m	
Degree of pollution in accordance with EN 60664-1	2 (non-conductive pollution)	
Overvoltage category in accordance with IEC 60364-4-443:1999	II	
EN 60529 protection	IP20	
<b>Environmental conditions</b>		
Temperature Operation Nominal	5 to 40°C	
Maximum <sup>9)</sup>	55°C	
Storage	-25 to 55°C	
Transport	-25 to 70°C	
Relative humidity Operation	5 to 85%	
Storage	5 to 95%	
Transport	Max. 95% at 40°C	
<b>Mechanical characteristics</b>		
Dimensions Width	58.5 mm	
Height	257 mm	
Depth	220 mm	
Weight	2.5 kg	

Table 16: 8V1016.50-2, 8V1016.501-2 - Technical data

- 1) In the USA, TT and TN power mains are commonly referred to as "Delta/Wye with grounded Wye neutral".
- 2) Limit values from EN 61800-3 C3 (second environment).
- 3) The permissible input voltage range is reduced when using motor holding brakes. The input voltage range should be selected so that the proper supply voltage for the motor holding brake can be maintained.
- 4) The current requirements depend on the configuration of the ACOPOS servo drive.
- 5) Valid in the following conditions: 230 VAC mains input voltage, nominal switching frequency, 40°C ambient temperature, installation altitude <500 m above sea level.
- 6) Value for the nominal switching frequency.
- 7) The module's electrical output frequency (SCTRL\_SPEED\_ACT \* MOTOR\_POLEPAIRS) is monitored to protect against dual use in accordance with EC 428/2009 | 3A225. If the electrical output frequency of the module exceeds the limit value of 600 Hz uninterrupted for more than 0.5 s, then the current movement is aborted and error 6060 is output (power unit: limit speed exceeded).
- 8) Continuous operation of ACOPOS servo drives at altitudes ranging from 500 m to 2000 m above sea level is possible (taking the specified continuous current reductions into consideration). Requirements that go above and beyond this need to be arranged with B&R.
- 9) Continuous operation of ACOPOS servo drives at ambient temperatures ranging from 40°C to max. 55°C is possible (taking the specified continuous current reductions into consideration), but this will result in a shorter service life.

2.3.5 Wiring

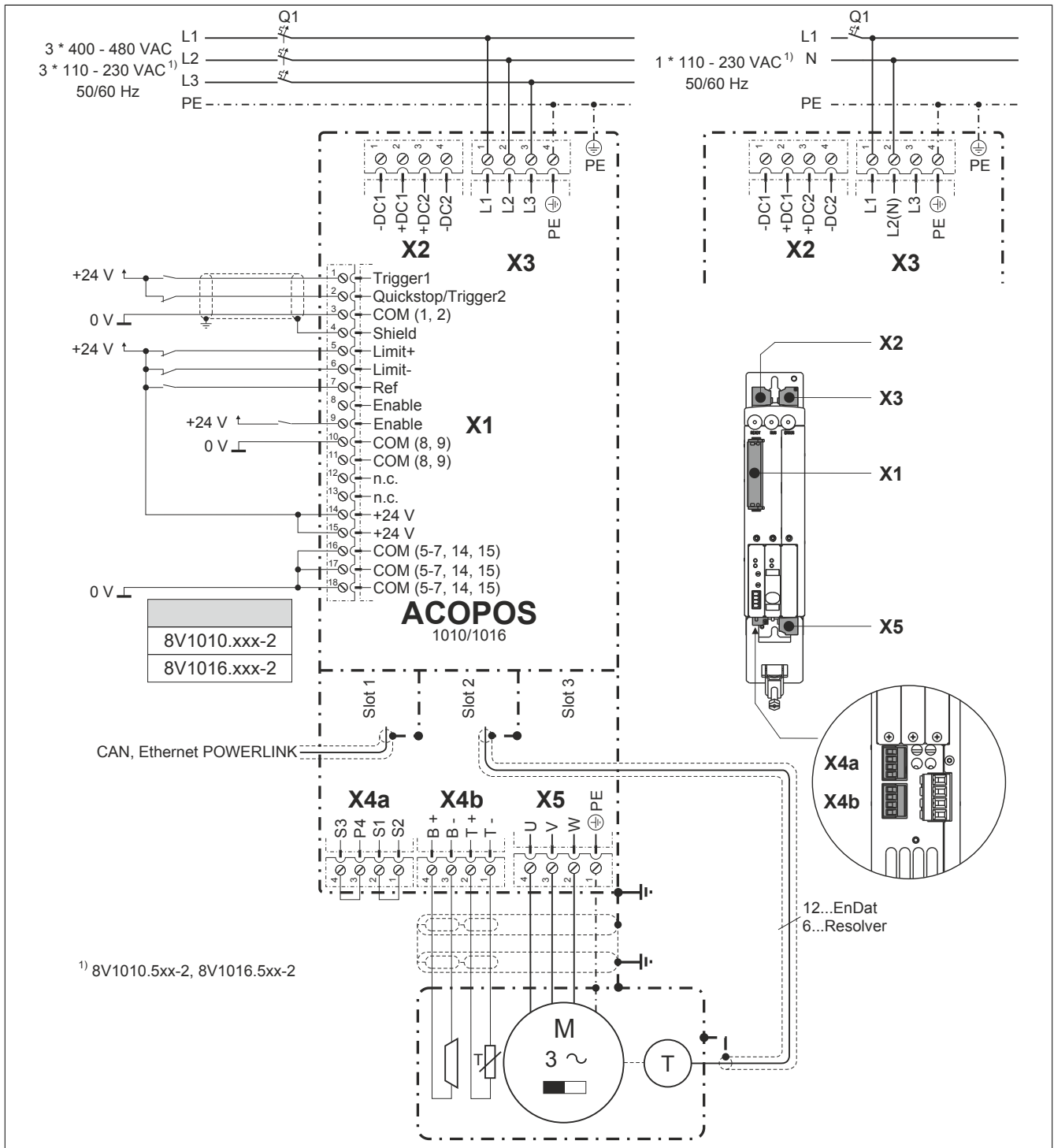
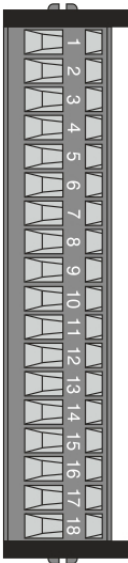


Figure 13: ACOPOS 1010, 1016 - Pinout overview

### 2.3.5.1 X1 connector - Pinout

X1	Pin	Name	Function
	1	Trigger1	Trigger 1
	2	Quickstop/Trigger2	Quickstop/Trigger2
	3	COM (1, 2)	Trigger 1, Quickstop/Trigger2 0 V
	4	Shield	Shield
	5	Limit+	Positive HW limit
	6	Limit-	Negative HW limit
	7	Ref	Reference switch
	8	Enable <sup>1)</sup>	Enable
	9	Enable <sup>1)</sup>	Enable
	10	COM (8, 9)	Enable 0 V
	11	COM (8, 9)	Enable 0 V
	12	---	---
	13	---	---
	14	+24 V	+24 V supply
	15	+24 V	+24 V supply
	16	COM (5-7, 14, 15)	0 V supply
	17	COM (5-7, 14, 15)	0 V supply
	18	COM (5-7, 14, 15)	0 V supply

The following connections are linked with each other internally in the device:

- Pin 8 --> Pin 9 (Enable)
- Pin 10 --> Pin 11 (Enable 0 V)
- Pin 14 --> Pin 15 (Supply +24 V)
- Pin 16 --> Pin 17 --> Pin 18 (Supply 0 V)

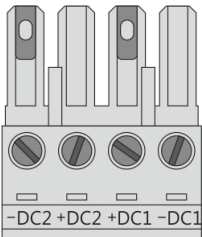
Terminal cross sections see "Overview of clampable cross sections" on page 245

Table 17: X1 connector - Pinout

1) The wiring is not permitted to exceed a total length of 30 m.

### 2.3.5.2 X2 connector - Pinout

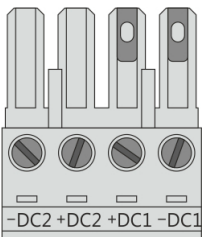
#### 2.3.5.2.1 8V1010.0xx-2, 8V1016.0xx-2

X2	Pin	Name	Function
	1	-DC1	U DC bus -
	2	+DC1	U DC bus +
	3	+DC2	U DC bus +
	4	-DC2	U DC bus -

Terminal cross sections see "Overview of clampable cross sections" on page 245

Table 18: X2 connector - Pinout

#### 2.3.5.2.2 8V1010.5xx-2, 8V1016.5xx-2

X2	Pin	Name	Function
	1	-DC1	U DC bus -
	2	+DC1	U DC bus +
	3	+DC2	U DC bus +
	4	-DC2	U DC bus -

Terminal cross sections see "Overview of clampable cross sections" on page 245

Table 19: X2 connector - Pinout

## Warning!

Only DC bus circuits of ACOPOS servo drives with the same supply voltage range are permitted to be connected in a group.

See "Table 161: Supply voltage range for ACOPOS servo drives" on page 204.

Therefore, the DC bus circuits of ACOPOS servo drives 8Vxxxx.5xx-2 and 8Vxxxx.0xx-2 are not allowed to be linked! For this reason, the X2 plugs for ACOPOS servo drives 8Vxxxx.5xx-2 and 8Vxxxx.0xx-2 are keyed differently.

All ACOPOS servo drives 8Vxxxx.5xx-2 with a single-phase supply that should have their DC buses connected together must be connected to the same phase! If this is not done, the DC bus voltage increases to a level that is not permitted, causing the devices to be destroyed!

### 2.3.5.3 X3 connector - Pinout

## Danger!

Servo drives are not permitted to be operated directly on IT and TN-S mains with a grounded phase conductor and protective ground conductor!

#### 2.3.5.3.1 8V1010.0xx-2, 8V1016.0xx-2

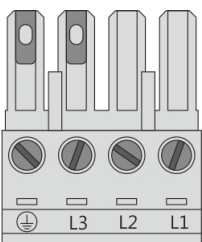
X3	Pin	Name	Function
	1	L1	Power mains connection L1
	2	L2	Power mains connection L2
	3	L3	Power mains connection L3
	4	PE	Protective ground conductor
Terminal cross sections see "Overview of clampable cross sections" on page 245			

Table 20: X3 connector - Pinout

#### 2.3.5.3.2 8V1010.5xx-2, 8V1016.5xx-2

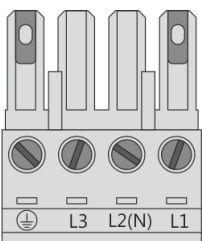
X3	Pin	Name	Function
	1	L1	Power mains connection L1
	2	L2(N)	Power mains connection N
	3	L3	---
	4	PE	Protective ground conductor
Terminal cross sections see "Overview of clampable cross sections" on page 245			

Table 21: X3 connector - Pinout

2.3.5.4 X4a, X4b connectors - Pinout

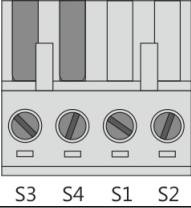
X4a	Pin	Name	Function
	1	S2 <sup>1)</sup>	Activation, supply for the external holding brake (+)
	2	S1 <sup>1)</sup>	Activation for the external holding brake (+)
	3	P4	Activation, supply for the external holding brake (-)
	4	S3	Activation for the external holding brake (-)
Terminal cross sections see "Overview of clampable cross sections" on page 245			

Table 22: X4a connector - Pinout

- 1) If the holding brake is connected via an additional external relay contact (ground-in e.g. via the connections S1/S2) instead of via the internal transistor, then the internal quenching circuit has no effect! In this case, the customer must make sure that neither the relay contact nor the braking coil are damaged when switching off the brake. This can be done by interconnecting the coil or - better still - interconnecting the contact with a quenching circuit.

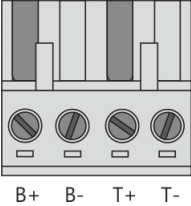
X4b	Pin	Name	Function
	1	T-	Temperature sensor -
	2	T+	Temperature sensor +
	3	B- <sup>1)</sup>	Brake -
	4	B+ <sup>1)</sup>	Brake +

Table 23: X4b connector - Pinout

- 1) If the holding brake is connected via an additional external relay contact (ground-in e.g. via the connections S1/S2) instead of via the internal transistor, then the internal quenching circuit has no effect! In this case, the customer must make sure that neither the relay contact nor the braking coil are damaged when switching off the brake. This can be done by interconnecting the coil or - better still - interconnecting the contact with a quenching circuit.

**Danger!**

The connections for the motor temperature sensors and the motor holding brake are isolated circuits. Therefore, these connections are only allowed to be connected to devices or components with at least safe isolation in accordance with IEC 60364-4-41 or EN 61800-5-1.

**Caution!**

If B+ and B- are swapped when connecting the permanent magnet holding brakes, then the brakes cannot be opened! ACOPOS servo drives cannot determine if a holding brake is connected with reverse polarity!

### 2.3.5.4.1 Wiring the connections for the motor holding brake

The supply, activation and monitoring of the output for the motor holding brake can take place via the X4a connector in three different ways:

	Figure	Description
1		<ul style="list-style-type: none"> <li>• <b>Supply:</b> Internally by the ACOPOS servo drive</li> <li>• <b>Activation:</b> Internally by the ACOPOS servo drive</li> <li>• <b>Monitoring:</b> Internally by the ACOPOS servo drive</li> </ul> <p>A jumper must be placed between S1 and S2 as well as S3 and S4 on the X4a connector. <sup>1)</sup></p>
2		<ul style="list-style-type: none"> <li>• <b>Supply:</b> Internally by the ACOPOS servo drive</li> <li>• <b>Activation:</b> Internally by the ACOPOS servo drive and also possible externally using potential-free contacts <sup>2)</sup></li> <li>• <b>Monitoring:</b> Internally by the ACOPOS servo drive</li> </ul> <p><b>Information:</b> The parameters for internal monitoring via the ACOPOS must be set according to the requirements of the application. <sup>3)</sup></p>
3		<ul style="list-style-type: none"> <li>• <b>Supply:</b> External</li> <li>• <b>Activation:</b> External</li> <li>• <b>Monitoring:</b> External</li> </ul> <p><b>Information:</b> ACOPOS internal monitoring cannot be used here; therefore, it must be disabled using software. <sup>4)</sup></p>

Table 24: Activation for the external holding brake

- 1) Both jumpers are already on the X4a connector delivered with the ACOPOS servo drives.
- 2) External potential-free contacts can be connected between S1 and S2 as well as between S3 and S4. This makes it possible to activate the holding brake using an external safety circuit independent of the control integrated in the ACOPOS servo drive.
- 3) The parameters are set using ParID 90 (1 ... internal monitoring active; 5 ... internal monitoring not active).
- 4) Deactivation takes place using ParID 90 (5 ... internal monitoring not active).

### 2.3.5.5 X5 connector - Pinout

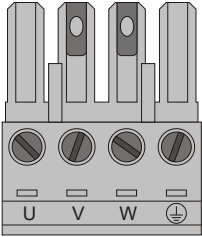
X5	Pin	Name	Function
	1	PE	Protective ground conductor
	2	W	Motor connection W
	3	V	Motor connection V
	4	U	Motor connection U
Terminal cross sections see "Overview of clampable cross sections" on page 245			

Table 25: X5 connector - Pinout

### 2.3.5.6 Additional protective ground connection (PE)

The protective ground conductor is connected to the M5 threaded bolt provided using a cable lug. For additional information regarding dimensioning, see "Protective ground connection (PE)" on page 204.

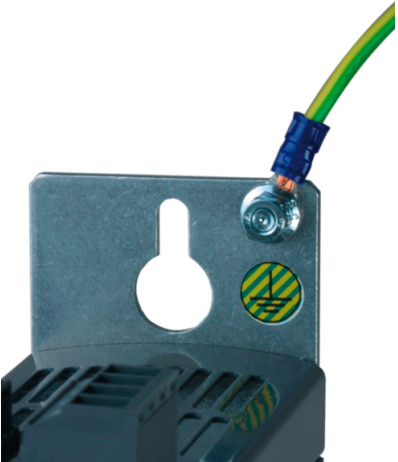
Figure	Pin	Name	Function					
	---	PE	Protective ground conductor					
	<table border="1"> <thead> <tr> <th>Terminal cross sections</th> <th>[mm<sup>2</sup>]</th> <th>AWG</th> </tr> </thead> <tbody> <tr> <td>Cable lug for M5 threaded bolt</td> <td>0.25 - 16</td> <td>23 - 5</td> </tr> </tbody> </table>			Terminal cross sections	[mm <sup>2</sup> ]	AWG	Cable lug for M5 threaded bolt	0.25 - 16
Terminal cross sections	[mm <sup>2</sup> ]	AWG						
Cable lug for M5 threaded bolt	0.25 - 16	23 - 5						

Table 26: Protective ground connection (PE) - ACOPOS

## Danger!

**Before turning on the servo drive, make sure that the housing is properly connected to ground (PE rail). The ground connection must be established even when testing the drive or operating it for a short time!**

### 2.3.5.7 Input/Output circuit diagram

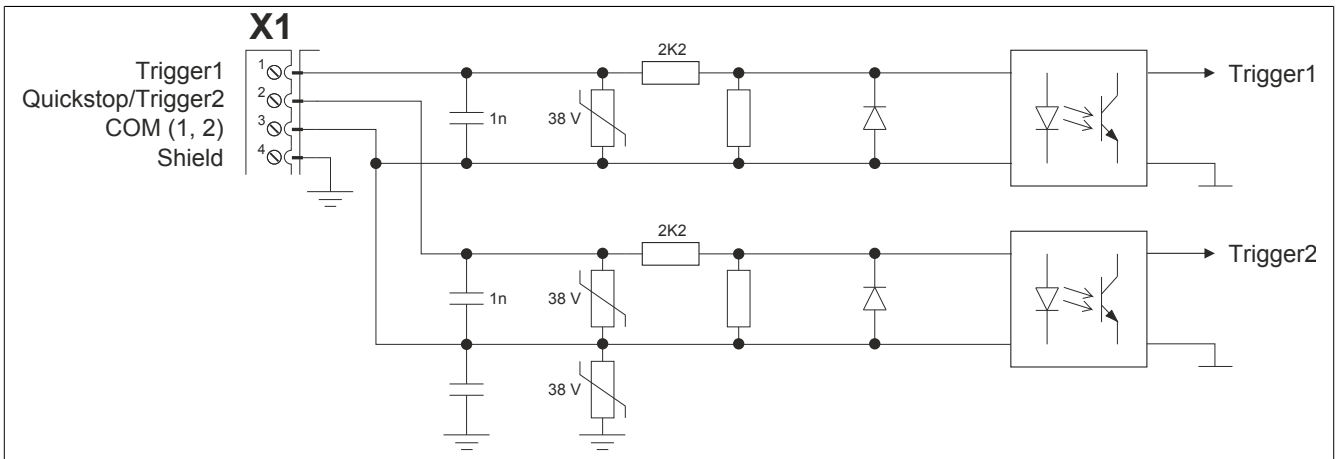


Figure 14: Trigger

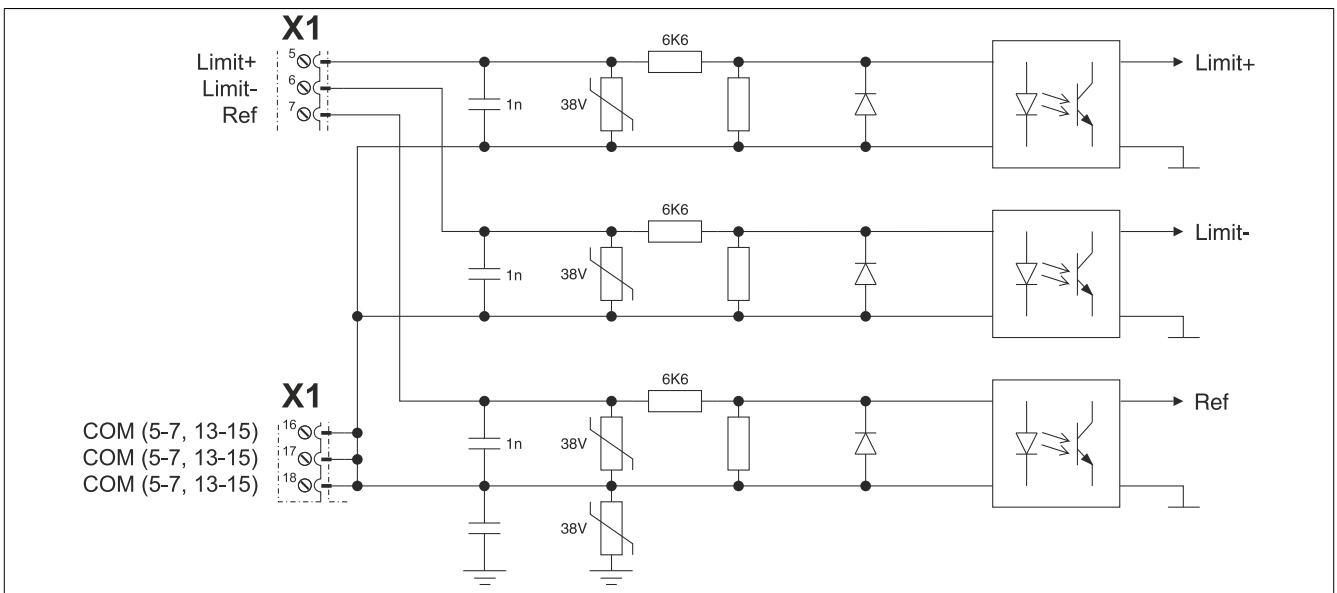


Figure 15: Limit

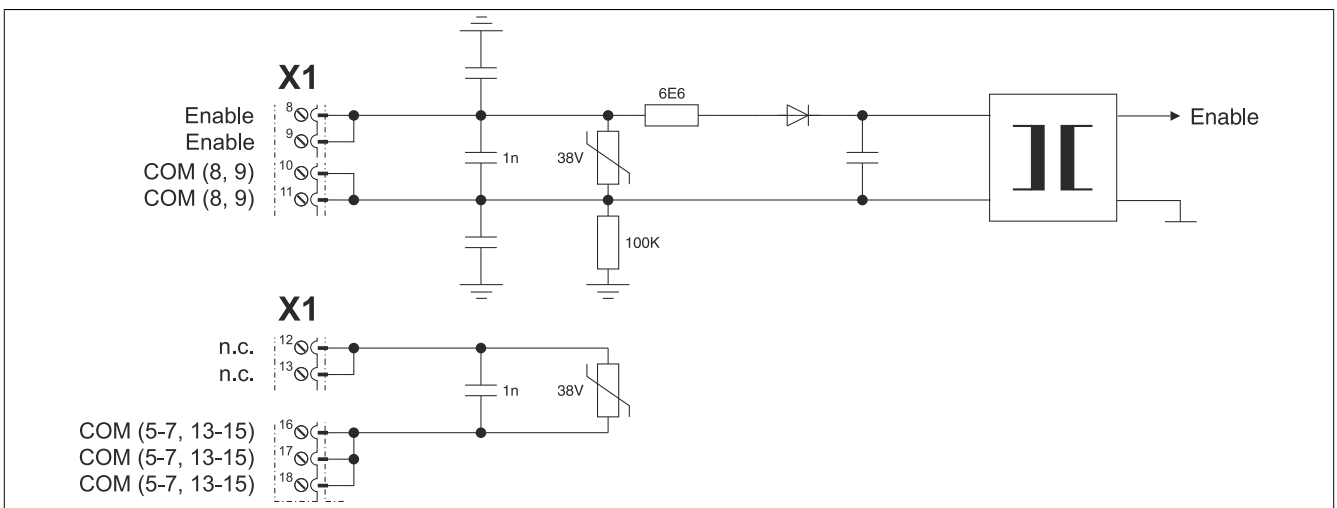


Figure 16: Enable

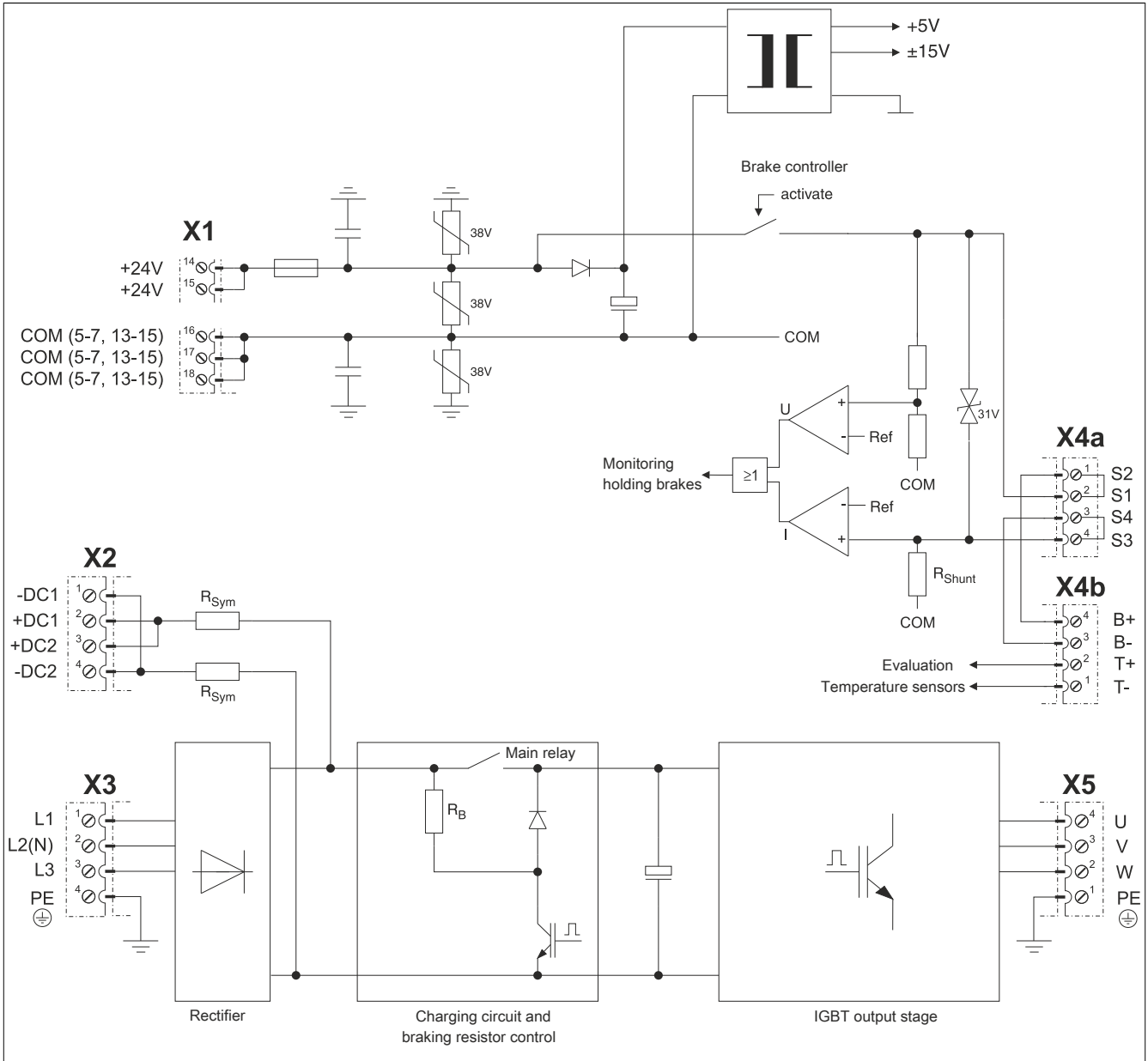


Figure 17: ACOPOS - Input/Output circuit diagram

## 2.4 ACOPOS 1022, 1045, 1090

### 2.4.1 ACOPOS 1022

#### 2.4.1.1 Order data


Model number	Short description	Figure
<b>Servo drives</b>		
8V1022.00-2	ACOPOS servo drive, 3x 400-480 V, 2.2 A, 1 kW, line filter, integrated braking resistor and electronic secure restart inhibit	
8V1022.001-2	ACOPOS servo drive, 3x 400-480 V, 2.2 A, 1 kW, coated, line filter, integrated braking resistor and electronic secure restart inhibit	
<b>Optional accessories</b>		
<b>Plug-in modules</b>		
8AC110.60-2	ACOPOS plug-in module, CAN interface	
8AC114.60-2	ACOPOS plug-in module, POWERLINK V2 interface	
8AC120.60-1	ACOPOS plug-in module, EnDat encoder and sine incremental encoder interface	
8AC121.60-1	ACOPOS plug-in module, HIPERFACE interface	
8AC122.60-3	ACOPOS plug-in module, resolver interface 10 kHz	
8AC123.60-1	ACOPOS plug-in module, incremental encoder and SSI absolute encoder interface	
8AC125.60-1	ACOPOS plug-in module, BiSS encoder interface 5 V	
8AC125.60-2	ACOPOS plug-in module, BiSS encoder interface 5V, baud rate 6.25 Mbit/s	
8AC125.61-2	ACOPOS plug-in module, BiSS encoder interface 12V, baud rate 6.25 Mbit/s	
8AC126.60-1	ACOPOS plug-in module, EnDat 2.2 encoder interface	
8AC130.60-1	ACOPOS plug-in module, 8 digital I/O configurable in pairs as 24 V input or as output 400/100 mA, 2 digital outputs 2 A, order TB712 terminal block separately.	
8AC131.60-1	ACOPOS plug-in module, 2 analog inputs $\pm 10$ V, 2 digital I/O points which can be configured as a 24 V input or 45 mA output, order TB712 terminal block separately.	
8AC132.60-1	ACOPOS plug-in module, 2 analog inputs $\pm 10$ V	
8AC140.60-3	ACOPOS plug-in module, CPU, x86 100 MHz Intel compatible, 32 MB DRAM, 32 kB SRAM, removable application memory: CompactFlash, 1 CAN interface, 1 Ethernet interface 100 Base-T, 1 PROFIBUS DP slave interface, 1 RS232 interface, 3 digital I/O can be configured as 24 VDC input or 500 mA output, 1 analog input $\pm 10$ V, order program memory and 0TB708 terminal block separately.	
8AC140.61-3	ACOPOS plug-in module, CPU, ARNC0, x86 100 MHz Intel compatible, 32 MB DRAM, 32 kB SRAM, removable application memory: CompactFlash, 1 CAN interface, 1 Ethernet interface 100 Base-T, 1 PROFIBUS DP slave interface, 1 RS232 interface, 3 digital I/O can be configured as 24 VDC input or 500 mA output, 1 analog input $\pm 10$ V, order program memory and 0TB708 terminal block separately.	
8AC141.60-2	ACOPOS plug-in module, CPU, x86 100 MHz Intel compatible, 16 MB DRAM, 32 kB SRAM, removable application memory: CompactFlash, 2 CAN interfaces, 1 Ethernet interface 100 Base-T, 1 RS232 interface, 1 X2X Link Master interface, 3 digital I/O can be configured as 24 VDC input or output 500 mA, 1 analog input $\pm 10$ V, order program memory and 0TB704 and 0TB708 terminal blocks separately	
8AC141.61-3	ACOPOS plug-in module, CPU, ARNC0, x86 100 MHz Intel compatible, 32 MB DRAM, 32 kB SRAM, removable application memory: CompactFlash, 2 CAN interfaces, 1 Ethernet interface 100 Base-T, 1 RS232 interface, 1 X2X Link Master interface, 3 digital I/O can be configured as 24 VDC input or output 500 mA, 1 analog input $\pm 10$ V, order program memory and 0TB704 and 0TB708 terminal blocks separately	
<b>Shielding component sets</b>		
8X0010.00-1	ACOPOS shielding components set for 8V1022.xxx-x up to 8V1090.xxx-x	
<b>Terminal sets</b>		
8X0001.00-1	ACOPOS accessories, plug set for 8V1010.00 and 8V1090.00 (3 phase)	

Table 27: 8V1022.00-2, 8V1022.001-2 - Order data

## 2.4.1.2 Technical data

Product ID	8V1022.00-2	8V1022.001-2
<b>General information</b>		
B&R ID code	0x1284	0xA099
Slots for plug-in modules	4	
Certification c-UL-us	Yes	
<b>Power mains connection</b>		
Permissible power mains forms	TT, TN <sup>1)</sup>	
Mains input voltage	3x 400 VAC to 480 VAC ±10%	
Frequency	50 / 60 Hz ±4%	
Installed load	Max. 3 kVA	
Starting current at 400 VAC	4 A	
Switch-on interval	>10 s	
Integrated line filter in accordance with EN 61800-3, Category C3 <sup>2)</sup>	Yes	
Power loss at max. device power without braking resistor	Approx. 120 W	
<b>DC bus connection</b>		
DC bus capacitance	235 µF	
<b>24 VDC supply</b>		
Input voltage <sup>3)</sup>	24 VDC ±25%	
Input capacitance	8200 µF	
Power consumption <sup>4)</sup>	Max. 2.5 A + current for motor holding brake	
<b>Motor connection</b>		
Quantity	1	
Continuous current <sup>5)</sup>	2.2 A <sub>eff</sub>	
Reduction of continuous current depending on the ambient temperature		
Mains input voltage: 400 VAC		
Switching frequency 5 kHz	No reduction	
Switching frequency 10 kHz	No reduction	
Switching frequency 20 kHz	No reduction <sup>6)</sup>	
Mains input voltage: 480 VAC		
Switching frequency 5 kHz	No reduction	
Switching frequency 10 kHz	No reduction	
Switching frequency 20 kHz	0.13 A <sub>eff</sub> per °C (starting at 51°C) <sup>6)</sup>	
Reduction of continuous current depending on the altitude		
Starting at 500 m above sea level	0.22 A <sub>eff</sub> per 1000 m	
Peak current	14 A <sub>eff</sub>	
Nominal switching frequency	20 kHz	
Possible switching frequencies	5 / 10 / 20 kHz	
Electrical stress of the connected motor in accordance with IEC TS 60034-25	Limit value curve A	
Max. motor line length	25 m	
Protective measures		
Overload protection	Yes	
Short circuit and ground fault protection	Yes	
Max. output frequency	600 Hz <sup>7)</sup>	
<b>Motor holding brake connection</b>		
Max. output current	1 A	
Max. number of switching cycles	Unlimited since handled electronically	
<b>Braking resistors</b>		
Peak power output	3.5 kW	
Continuous power	130 W	
<b>Limit switch and reference inputs</b>		
Quantity	3	
Wiring	Sink	
Electrical isolation		
Input - ACOPOS	Yes	
Input - Input	No	
Input voltage		
Nominal	24 VDC	
Maximum	30 VDC	
Switching threshold		
Low	<5 V	
High	>15 V	
Input current at nominal voltage	Approx. 4 mA	
Switching delay	Max. 2.0 ms	
Modulation compared to ground potential	Max. ±38 V	
<b>Enable inputs</b>		
Quantity	1	
Wiring	Sink	

Table 28: 8V1022.00-2, 8V1022.001-2 - Technical data

Product ID	8V1022.00-2	8V1022.001-2
Electrical isolation Input - ACOPOS	Yes	
Input voltage Nominal Maximum	24 VDC 30 VDC	
Input current at nominal voltage	Approx. 30 mA	
Switching threshold Low High	<5 V >15 V	
Switching delay Enable 0 -> 1, ready for PWM Enable 1 -> 0, PWM off	Max. 100 µs Max. 2.0 ms	
Modulation compared to ground potential	Max. ±38 V	
<b>Trigger inputs</b>		
Quantity	2	
Wiring	Sink	
Electrical isolation Input - ACOPOS Input - Input	Yes No	
Input voltage Nominal Maximum	24 VDC 30 VDC	
Switching threshold Low High	<5 V >15 V	
Input current at nominal voltage	Approx. 10 mA	
Switching delay Positive edge Negative edge	52 µs ±0.5 µs (digitally filtered) 53 µs ±0.5 µs (digitally filtered)	
Modulation compared to ground potential	Max. ±38 V	
<b>Operating conditions</b>		
Permitted mounting orientations Hanging vertically Lying horizontally Standing horizontally	Yes Yes No	
Installation at altitudes above sea level Nominal Maximum <sup>8)</sup>	0 to 500 m 2000 m	
Degree of pollution in accordance with EN 60664-1	2 (non-conductive pollution)	
Overvoltage category in accordance with IEC 60364-4-443:1999	II	
EN 60529 protection	IP20	
<b>Environmental conditions</b>		
Temperature Operation Nominal Maximum <sup>9)</sup> Storage Transport	5 to 40°C 55°C -25 to 55°C -25 to 70°C	
Relative humidity Operation Storage Transport	5 to 85% 5 to 95% Max. 95% at 40°C	
<b>Mechanical characteristics</b>		
Dimensions Width Height Depth	70.5 mm 375 mm 235.5 mm	
Weight	4.0 kg	

Table 28: 8V1022.00-2, 8V1022.001-2 - Technical data

- 1) In the USA, TT and TN power mains are commonly referred to as "Delta/Wye with grounded Wye neutral".
- 2) Limit values from CISPR11, group 2, class A (second environment).
- 3) The permissible input voltage range is reduced when using motor holding brakes. The input voltage range should be selected so that the proper supply voltage for the motor holding brake can be maintained.
- 4) The current requirements depend on the configuration of the ACOPOS servo drive.
- 5) Valid in the following conditions: 400 VAC mains input voltage, nominal switching frequency, 40°C ambient temperature, installation altitude <500 m above sea level.
- 6) Value for the nominal switching frequency.
- 7) The module's electrical output frequency (SCTRL\_SPEED\_ACT \* MOTOR\_POLEPAIRS) is monitored to protect against dual use in accordance with EC 428/2009 | 3A225. If the electrical output frequency of the module exceeds the limit value of 600 Hz uninterrupted for more than 0.5 s, then the current movement is aborted and error 6060 is output (power unit: limit speed exceeded).
- 8) Continuous operation of ACOPOS servo drives at altitudes ranging from 500 m to 2000 m above sea level is possible (taking the specified continuous current reductions into consideration). Requirements that go above and beyond this need to be arranged with B&R.
- 9) Continuous operation of ACOPOS servo drives at ambient temperatures ranging from 40°C to max. 55°C is possible (taking the specified continuous current reductions into consideration), but this will result in a shorter service life.

## 2.4.2 ACOPOS 1045

### 2.4.2.1 Order data


Model number	Short description	Figure
	<b>Servo drives</b>	
8V1045.00-2	ACOPOS servo drive, 3x 400-480 V, 4.4 A, 2 kW, line filter, integrated braking resistor and electronic secure restart inhibit	
8V1045.001-2	ACOPOS servo drive, 3x 400-480 V, 4.4 A, 2 kW, coated, line filter, integrated braking resistor and electronic secure restart inhibit	
	<b>Optional accessories</b>	
	<b>Plug-in modules</b>	
8AC110.60-2	ACOPOS plug-in module, CAN interface	
8AC114.60-2	ACOPOS plug-in module, POWERLINK V2 interface	
8AC120.60-1	ACOPOS plug-in module, EnDat encoder and sine incremental encoder interface	
8AC121.60-1	ACOPOS plug-in module, HIPERFACE interface	
8AC122.60-3	ACOPOS plug-in module, resolver interface 10 kHz	
8AC123.60-1	ACOPOS plug-in module, incremental encoder and SSI absolute encoder interface	
8AC125.60-1	ACOPOS plug-in module, BiSS encoder interface 5 V	
8AC125.60-2	ACOPOS plug-in module, BiSS encoder interface 5V, baud rate 6.25 Mbit/s	
8AC125.61-2	ACOPOS plug-in module, BiSS encoder interface 12V, baud rate 6.25 Mbit/s	
8AC126.60-1	ACOPOS plug-in module, EnDat 2.2 encoder interface	
8AC130.60-1	ACOPOS plug-in module, 8 digital I/O configurable in pairs as 24 V input or as output 400/100 mA, 2 digital outputs 2 A, order TB712 terminal block separately.	
8AC131.60-1	ACOPOS plug-in module, 2 analog inputs ±10 V, 2 digital I/O points which can be configured as a 24 V input or 45 mA output, order TB712 terminal block separately.	
8AC132.60-1	ACOPOS plug-in module, 2 analog inputs ±10 V	
8AC140.60-3	ACOPOS plug-in module, CPU, x86 100 MHz Intel compatible, 32 MB DRAM, 32 kB SRAM, removable application memory: CompactFlash, 1 CAN interface, 1 Ethernet interface 100 Base-T, 1 PROFIBUS DP slave interface, 1 RS232 interface, 3 digital I/O can be configured as 24 VDC input or 500 mA output, 1 analog input ±10 V, order program memory and 0TB708 terminal block separately.	
8AC140.61-3	ACOPOS plug-in module, CPU, ARNC0, x86 100 MHz Intel compatible, 32 MB DRAM, 32 kB SRAM, removable application memory: CompactFlash, 1 CAN interface, 1 Ethernet interface 100 Base-T, 1 PROFIBUS DP slave interface, 1 RS232 interface, 3 digital I/O can be configured as 24 VDC input or 500 mA output, 1 analog input ±10 V, order program memory and 0TB708 terminal block separately.	
8AC141.60-2	ACOPOS plug-in module, CPU, x86 100 MHz Intel compatible, 16 MB DRAM, 32 kB SRAM, removable application memory: CompactFlash, 2 CAN interfaces, 1 Ethernet interface 100 Base-T, 1 RS232 interface, 1 X2X Link Master interface, 3 digital I/O can be configured as 24 VDC input or output 500 mA, 1 analog input ±10 V, order program memory and 0TB704 and 0TB708 terminal blocks separately	
8AC141.61-3	ACOPOS plug-in module, CPU, ARNC0, x86 100 MHz Intel compatible, 32 MB DRAM, 32 kB SRAM, removable application memory: CompactFlash, 2 CAN interfaces, 1 Ethernet interface 100 Base-T, 1 RS232 interface, 1 X2X Link Master interface, 3 digital I/O can be configured as 24 VDC input or output 500 mA, 1 analog input ±10 V, order program memory and 0TB704 and 0TB708 terminal blocks separately	
	<b>Shielding component sets</b>	
8X0010.00-1	ACOPOS shielding components set for 8V1022.xxx-x up to 8V1090.xxx-x	
	<b>Terminal sets</b>	
8X0001.00-1	ACOPOS accessories, plug set for 8V1010.00 and 8V1090.00 (3 phase)	

Table 29: 8V1045.00-2, 8V1045.001-2 - Order data

## 2.4.2.2 Technical data

Product ID	8V1045.00-2	8V1045.001-2
<b>General information</b>		
B&R ID code	0x12C7	0xA09A
Slots for plug-in modules	4	
Certification c-UL-us	Yes	
<b>Power mains connection</b>		
Permissible power mains forms	TT, TN <sup>1)</sup>	
Mains input voltage	3x 400 VAC to 480 VAC ±10%	
Frequency	50 / 60 Hz ±4%	
Installed load	Max. 5 kVA	
Starting current at 400 VAC	7 A	
Switch-on interval	>10 s	
Integrated line filter in accordance with EN 61800-3, Category C3 <sup>2)</sup>	Yes	
Power loss at max. device power without braking resistor	Approx. 180 W	
<b>DC bus connection</b>		
DC bus capacitance	235 µF	
<b>24 VDC supply</b>		
Input voltage <sup>3)</sup>	24 VDC ±25%	
Input capacitance	8200 µF	
Power consumption <sup>4)</sup>	Max. 2.5 A + current for motor holding brake	
<b>Motor connection</b>		
Quantity	1	
Continuous current <sup>5)</sup>	4.4 A <sub>eff</sub>	
Reduction of continuous current depending on the ambient temperature		
Mains input voltage: 400 VAC		
Switching frequency 5 kHz	No reduction	
Switching frequency 10 kHz	No reduction	
Switching frequency 20 kHz	0.13 A <sub>eff</sub> per °C (starting at 45°C) <sup>6)</sup>	
Mains input voltage: 480 VAC		
Switching frequency 5 kHz	No reduction	
Switching frequency 10 kHz	No reduction	
Switching frequency 20 kHz	0.13 A <sub>eff</sub> per °C (starting at 35°C) <sup>6)</sup>	
Reduction of continuous current depending on the altitude		
Starting at 500 m above sea level	0.44 A <sub>eff</sub> per 1000 m	
Peak current	24 A <sub>eff</sub>	
Nominal switching frequency	20 kHz	
Possible switching frequencies	5 / 10 / 20 kHz	
Electrical stress of the connected motor in accordance with IEC TS 60034-25	Limit value curve A	
Max. motor line length	25 m	
Protective measures		
Overload protection	Yes	
Short circuit and ground fault protection	Yes	
Max. output frequency	600 Hz <sup>7)</sup>	
<b>Motor holding brake connection</b>		
Max. output current	1 A	
Max. number of switching cycles	Unlimited since handled electronically	
<b>Braking resistors</b>		
Peak power output	7 kW	
Continuous power	200 W	
<b>Limit switch and reference inputs</b>		
Quantity	3	
Wiring	Sink	
Electrical isolation		
Input - ACOPOS	Yes	
Input - Input	No	
Input voltage		
Nominal	24 VDC	
Maximum	30 VDC	
Switching threshold		
Low	<5 V	
High	>15 V	
Input current at nominal voltage	Approx. 4 mA	
Switching delay	Max. 2.0 ms	
Modulation compared to ground potential	Max. ±38 V	
<b>Enable inputs</b>		
Quantity	1	
Wiring	Sink	

Table 30: 8V1045.00-2, 8V1045.001-2 - Technical data

Product ID	8V1045.00-2	8V1045.001-2
Electrical isolation Input - ACOPOS	Yes	
Input voltage Nominal	24 VDC	
Maximum	30 VDC	
Input current at nominal voltage	Approx. 30 mA	
Switching threshold Low	<5 V	
High	>15 V	
Switching delay Enable 0 -> 1, ready for PWM	Max. 100 µs	
Enable 1 -> 0, PWM off	Max. 2.0 ms	
Modulation compared to ground potential	Max. ±38 V	
<b>Trigger inputs</b>		
Quantity	2	
Wiring	Sink	
Electrical isolation Input - ACOPOS	Yes	
Input - Input	No	
Input voltage Nominal	24 VDC	
Maximum	30 VDC	
Switching threshold Low	<5 V	
High	>15 V	
Input current at nominal voltage	Approx. 10 mA	
Switching delay Positive edge	52 µs ±0.5 µs (digitally filtered)	
Negative edge	53 µs ±0.5 µs (digitally filtered)	
Modulation compared to ground potential	Max. ±38 V	
<b>Operating conditions</b>		
Permitted mounting orientations Hanging vertically	Yes	
Lying horizontally	Yes	
Standing horizontally	No	
Installation at altitudes above sea level Nominal	0 to 500 m	
Maximum <sup>8)</sup>	2000 m	
Degree of pollution in accordance with EN 60664-1	2 (non-conductive pollution)	
Overvoltage category in accordance with IEC 60364-4-443:1999	II	
EN 60529 protection	IP20	
<b>Environmental conditions</b>		
Temperature Operation Nominal	5 to 40°C	
Maximum <sup>9)</sup>	55°C	
Storage	-25 to 55°C	
Transport	-25 to 70°C	
Relative humidity Operation	5 to 85%	
Storage	5 to 95%	
Transport	Max. 95% at 40°C	
<b>Mechanical characteristics</b>		
Dimensions Width	70.5 mm	
Height	375 mm	
Depth	235.5 mm	
Weight	4.1 kg	

Table 30: 8V1045.00-2, 8V1045.001-2 - Technical data

- 1) In the USA, TT and TN power mains are commonly referred to as "Delta/Wye with grounded Wye neutral".
- 2) Limit values from CISPR11, group 2, class A (second environment).
- 3) The permissible input voltage range is reduced when using motor holding brakes. The input voltage range should be selected so that the proper supply voltage for the motor holding brake can be maintained.
- 4) The current requirements depend on the configuration of the ACOPOS servo drive.
- 5) Valid in the following conditions: 400 VAC mains input voltage, nominal switching frequency, 40°C ambient temperature, installation altitude <500 m above sea level.
- 6) Value for the nominal switching frequency.
- 7) The module's electrical output frequency (SCTRL\_SPEED\_ACT \* MOTOR\_POLEPAIRS) is monitored to protect against dual use in accordance with EC 428/2009 | 3A225. If the electrical output frequency of the module exceeds the limit value of 600 Hz uninterrupted for more than 0.5 s, then the current movement is aborted and error 6060 is output (power unit: limit speed exceeded).
- 8) Continuous operation of ACOPOS servo drives at altitudes ranging from 500 m to 2000 m above sea level is possible (taking the specified continuous current reductions into consideration). Requirements that go above and beyond this need to be arranged with B&R.
- 9) Continuous operation of ACOPOS servo drives at ambient temperatures ranging from 40°C to max. 55°C is possible (taking the specified continuous current reductions into consideration), but this will result in a shorter service life.

## 2.4.3 ACOPOS 1090

### 2.4.3.1 Order data


Model number	Short description	Figure
	<b>Servo drives</b>	
8V1090.00-2	ACOPOS servo drive, 3x 400-480 V, 8.8 A, 4 kW, line filter, integrated braking resistor and electronic secure restart inhibit	
8V1090.001-2	ACOPOS servo drive, 3x 400-480 V, 8.8 A, 4 kW, coated, line filter, integrated braking resistor and electronic secure restart inhibit	
	<b>Optional accessories</b>	
	<b>Plug-in modules</b>	
8AC110.60-2	ACOPOS plug-in module, CAN interface	
8AC114.60-2	ACOPOS plug-in module, POWERLINK V2 interface	
8AC120.60-1	ACOPOS plug-in module, EnDat encoder and sine incremental encoder interface	
8AC121.60-1	ACOPOS plug-in module, HIPERFACE interface	
8AC122.60-3	ACOPOS plug-in module, resolver interface 10 kHz	
8AC123.60-1	ACOPOS plug-in module, incremental encoder and SSI absolute encoder interface	
8AC125.60-1	ACOPOS plug-in module, BiSS encoder interface 5 V	
8AC125.60-2	ACOPOS plug-in module, BiSS encoder interface 5V, baud rate 6.25 Mbit/s	
8AC125.61-2	ACOPOS plug-in module, BiSS encoder interface 12V, baud rate 6.25 Mbit/s	
8AC126.60-1	ACOPOS plug-in module, EnDat 2.2 encoder interface	
8AC130.60-1	ACOPOS plug-in module, 8 digital I/O configurable in pairs as 24 V input or as output 400/100 mA, 2 digital outputs 2 A, order TB712 terminal block separately.	
8AC131.60-1	ACOPOS plug-in module, 2 analog inputs ±10 V, 2 digital I/O points which can be configured as a 24 V input or 45 mA output, order TB712 terminal block separately.	
8AC132.60-1	ACOPOS plug-in module, 2 analog inputs ±10 V	
8AC140.60-3	ACOPOS plug-in module, CPU, x86 100 MHz Intel compatible, 32 MB DRAM, 32 kB SRAM, removable application memory: CompactFlash, 1 CAN interface, 1 Ethernet interface 100 Base-T, 1 PROFIBUS DP slave interface, 1 RS232 interface, 3 digital I/O can be configured as 24 VDC input or 500 mA output, 1 analog input ±10 V, order program memory and 0TB708 terminal block separately.	
8AC140.61-3	ACOPOS plug-in module, CPU, ARNC0, x86 100 MHz Intel compatible, 32 MB DRAM, 32 kB SRAM, removable application memory: CompactFlash, 1 CAN interface, 1 Ethernet interface 100 Base-T, 1 PROFIBUS DP slave interface, 1 RS232 interface, 3 digital I/O can be configured as 24 VDC input or 500 mA output, 1 analog input ±10 V, order program memory and 0TB708 terminal block separately.	
8AC141.60-2	ACOPOS plug-in module, CPU, x86 100 MHz Intel compatible, 16 MB DRAM, 32 kB SRAM, removable application memory: CompactFlash, 2 CAN interfaces, 1 Ethernet interface 100 Base-T, 1 RS232 interface, 1 X2X Link Master interface, 3 digital I/O can be configured as 24 VDC input or output 500 mA, 1 analog input ±10 V, order program memory and 0TB704 and 0TB708 terminal blocks separately	
8AC141.61-3	ACOPOS plug-in module, CPU, ARNC0, x86 100 MHz Intel compatible, 32 MB DRAM, 32 kB SRAM, removable application memory: CompactFlash, 2 CAN interfaces, 1 Ethernet interface 100 Base-T, 1 RS232 interface, 1 X2X Link Master interface, 3 digital I/O can be configured as 24 VDC input or output 500 mA, 1 analog input ±10 V, order program memory and 0TB704 and 0TB708 terminal blocks separately	
	<b>Shielding component sets</b>	
8X0010.00-1	ACOPOS shielding components set for 8V1022.xxx-x up to 8V1090.xxx-x	
	<b>Terminal sets</b>	
8X0001.00-1	ACOPOS accessories, plug set for 8V1010.00 and 8V1090.00 (3 phase)	

Table 31: 8V1090.00-2, 8V1090.001-2 - Order data

## 2.4.3.2 Technical data

Product ID	8V1090.00-2	8V1090.001-2
<b>General information</b>		
B&R ID code	0x12C8	0xA09B
Slots for plug-in modules	4	
Certification c-UL-us	Yes	
<b>Power mains connection</b>		
Permissible power mains forms	TT, TN <sup>1)</sup>	
Mains input voltage	3x 400 VAC to 480 VAC ±10%	
Frequency	50 / 60 Hz ±4%	
Installed load	Max. 10 kVA	
Starting current at 400 VAC	7 A	
Switch-on interval	>10 s	
Integrated line filter in accordance with EN 61800-3, Category C3 <sup>2)</sup>	Yes	
Power loss at max. device power without braking resistor	Approx. 200 W	
<b>DC bus connection</b>		
DC bus capacitance	470 µF	
<b>24 VDC supply</b>		
Input voltage <sup>3)</sup>	24 VDC ±25%	
Input capacitance	8200 µF	
Power consumption <sup>4)</sup>	Max. 2.5 A + current for motor holding brake	
<b>Motor connection</b>		
Quantity	1	
Continuous current <sup>5)</sup>	8.8 A <sub>eff</sub>	
Reduction of continuous current depending on the ambient temperature	No reduction 0.18 A <sub>eff</sub> per °C (starting at 54°C) <sup>6)</sup> 0.18 A <sub>eff</sub> per °C (starting at 30°C)	
Mains input voltage: 400 VAC Switching frequency 5 kHz Switching frequency 10 kHz Switching frequency 20 kHz Mains input voltage: 480 VAC Switching frequency 5 kHz Switching frequency 10 kHz Switching frequency 20 kHz	No reduction 0.18 A <sub>eff</sub> per °C (starting at 48°C) <sup>6)</sup> 0.18 A <sub>eff</sub> per °C (starting at 18°C)	
Reduction of continuous current depending on the altitude	0.88 A <sub>eff</sub> per 1000 m	
Starting at 500 m above sea level		
Peak current	24 A <sub>eff</sub>	
Nominal switching frequency	10 kHz	
Possible switching frequencies	5 / 10 / 20 kHz	
Electrical stress of the connected motor in accordance with IEC TS 60034-25	Limit value curve A	
Max. motor line length	25 m	
Protective measures		
Overload protection	Yes	
Short circuit and ground fault protection	Yes	
Max. output frequency	600 Hz <sup>7)</sup>	
<b>Motor holding brake connection</b>		
Max. output current	1 A	
Max. number of switching cycles	Unlimited since handled electronically	
<b>Braking resistors</b>		
Peak power output	7 kW	
Continuous power	200 W	
<b>Limit switch and reference inputs</b>		
Quantity	3	
Wiring	Sink	
Electrical isolation		
Input - ACOPOS	Yes	
Input - Input	No	
Input voltage		
Nominal	24 VDC	
Maximum	30 VDC	
Switching threshold		
Low	<5 V	
High	>15 V	
Input current at nominal voltage	Approx. 4 mA	
Switching delay	Max. 2.0 ms	
Modulation compared to ground potential	Max. ±38 V	
<b>Enable inputs</b>		
Quantity	1	
Wiring	Sink	

Table 32: 8V1090.00-2, 8V1090.001-2 - Technical data

Product ID	8V1090.00-2	8V1090.001-2
Electrical isolation Input - ACOPOS	Yes	
Input voltage Nominal Maximum	24 VDC 30 VDC	
Input current at nominal voltage	Approx. 30 mA	
Switching threshold Low High	<5 V >15 V	
Switching delay Enable 0 -> 1, ready for PWM Enable 1 -> 0, PWM off	Max. 100 µs Max. 2.0 ms	
Modulation compared to ground potential	Max. ±38 V	
<b>Trigger inputs</b>		
Quantity	2	
Wiring	Sink	
Electrical isolation Input - ACOPOS Input - Input	Yes No	
Input voltage Nominal Maximum	24 VDC 30 VDC	
Switching threshold Low High	<5 V >15 V	
Input current at nominal voltage	Approx. 10 mA	
Switching delay Positive edge Negative edge	52 µs ±0.5 µs (digitally filtered) 53 µs ±0.5 µs (digitally filtered)	
Modulation compared to ground potential	Max. ±38 V	
<b>Operating conditions</b>		
Permitted mounting orientations Hanging vertically Lying horizontally Standing horizontally	Yes Yes No	
Installation at altitudes above sea level Nominal Maximum <sup>8)</sup>	0 to 500 m 2000 m	
Degree of pollution in accordance with EN 60664-1	2 (non-conductive pollution)	
Overvoltage category in accordance with IEC 60364-4-443:1999	II	
EN 60529 protection	IP20	
<b>Environmental conditions</b>		
Temperature Operation Nominal Maximum <sup>9)</sup> Storage Transport	5 to 40°C 55°C -25 to 55°C -25 to 70°C	
Relative humidity Operation Storage Transport	5 to 85% 5 to 95% Max. 95% at 40°C	
<b>Mechanical characteristics</b>		
Dimensions Width Height Depth	70.5 mm 375 mm 235.5 mm	
Weight	4.4 kg	

Table 32: 8V1090.00-2, 8V1090.001-2 - Technical data

- 1) In the USA, TT and TN power mains are commonly referred to as "Delta/Wye with grounded Wye neutral".
- 2) Limit values from CISPR11, group 2, class A (second environment).
- 3) The permissible input voltage range is reduced when using motor holding brakes. The input voltage range should be selected so that the proper supply voltage for the motor holding brake can be maintained.
- 4) The current requirements depend on the configuration of the ACOPOS servo drive.
- 5) Valid in the following conditions: 400 VAC mains input voltage, nominal switching frequency, 40°C ambient temperature, installation altitude <500 m above sea level.
- 6) Value for the nominal switching frequency.
- 7) The module's electrical output frequency (SCTRL\_SPEED\_ACT \* MOTOR\_POLEPAIRS) is monitored to protect against dual use in accordance with EC 428/2009 | 3A225. If the electrical output frequency of the module exceeds the limit value of 600 Hz uninterrupted for more than 0.5 s, then the current movement is aborted and error 6060 is output (power unit: limit speed exceeded).
- 8) Continuous operation of ACOPOS servo drives at altitudes ranging from 500 m to 2000 m above sea level is possible (taking the specified continuous current reductions into consideration). Requirements that go above and beyond this need to be arranged with B&R.
- 9) Continuous operation of ACOPOS servo drives at ambient temperatures ranging from 40°C to max. 55°C is possible (taking the specified continuous current reductions into consideration), but this will result in a shorter service life.

### 2.4.4 Wiring

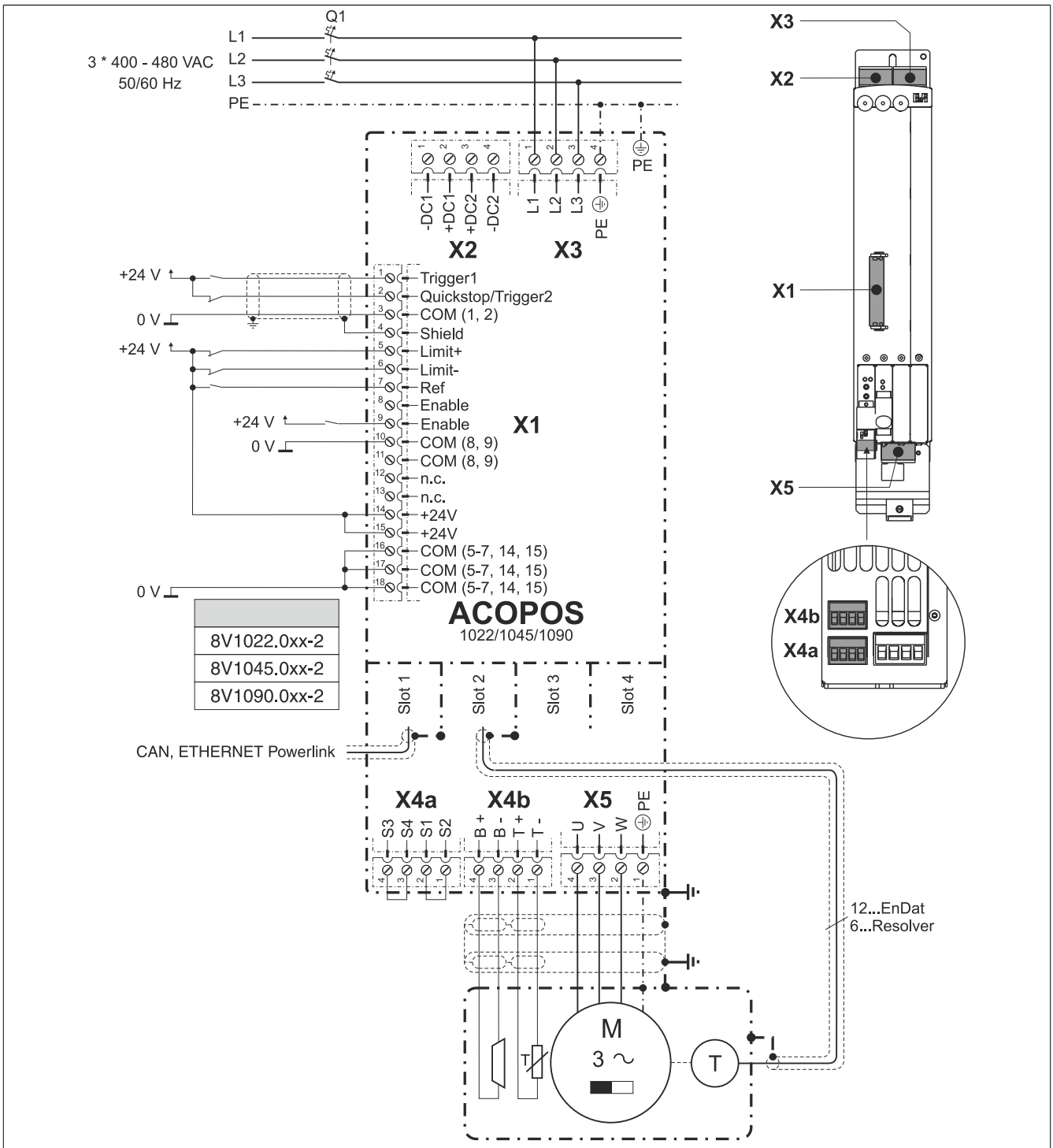
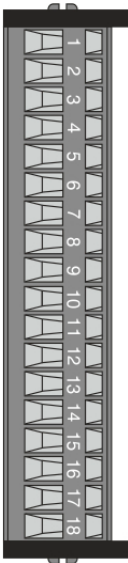


Figure 18: ACOPOS 1022, 1045, 1090 - Pinout overview

### 2.4.4.1 X1 connector - Pinout

X1	Pin	Name	Function
	1	Trigger1	Trigger 1
	2	Quickstop/Trigger2	Quickstop/Trigger2
	3	COM (1, 2)	Trigger 1, Quickstop/Trigger 2 0 V
	4	Shield	Shield
	5	Limit+	Positive HW limit
	6	Limit-	Negative HW limit
	7	Ref	Reference switch
	8	Enable <sup>1)</sup>	Enable
	9	Enable <sup>1)</sup>	Enable
	10	COM (8, 9)	Enable 0 V
	11	COM (8, 9)	Enable 0 V
	12	---	---
	13	---	---
	14	+24 V	+24 V supply
	15	+24 V	+24 V supply
	16	COM (5-7, 14, 15)	0 V supply
	17	COM (5-7, 14, 15)	0 V supply
	18	COM (5-7, 14, 15)	0 V supply

The following connections are linked with each other internally in the device:

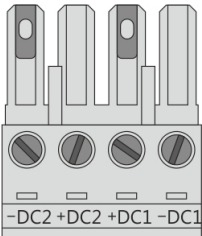
- Pin 8 --> Pin 9 (Enable)
- Pin 10 --> Pin 11 (Enable 0 V)
- Pin 14 --> Pin 15 (Supply +24 V)
- Pin 16 --> Pin 17 --> Pin 18 (Supply 0 V)

Terminal cross sections see "Overview of clampable cross sections" on page 245

Table 33: X1 connector - Pinout

1) The wiring is not permitted to exceed a total length of 30 m.

### 2.4.4.2 X2 connector - Pinout

X2	Pin	Name	Function
	1	-DC1	U DC bus -
	2	+DC1	U DC bus +
	3	+DC2	U DC bus +
	4	-DC2	U DC bus -

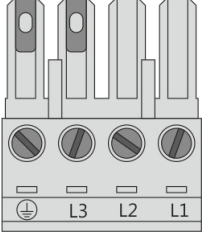
Terminal cross sections see "Overview of clampable cross sections" on page 245

Table 34: X2 connector - Pinout

### 2.4.4.3 X3 connector - Pinout

## Danger!

**Servo drives are not permitted to be operated directly on IT and TN-S mains with a grounded phase conductor and protective ground conductor!**

X3	Pin	Name	Function
	1	L1	Power mains connection L1
	2	L2	Power mains connection L2
	3	L3	Power mains connection L3
	4	PE	Protective ground conductor

Terminal cross sections see "Overview of clampable cross sections" on page 245

Table 35: X3 connector - Pinout

2.4.4.4 X4a, X4b connectors - Pinout

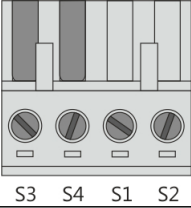
X4a	Pin	Name	Function
	1	S2 <sup>1)</sup>	Activation, supply for the external holding brake (+)
	2	S1 <sup>1)</sup>	Activation for the external holding brake (+)
	3	P4	Activation, supply for the external holding brake (-)
	4	S3	Activation for the external holding brake (-)
	Terminal cross sections see "Overview of clampable cross sections" on page 245		

Table 36: X4a connector - Pinout

- 1) If the holding brake is connected via an additional external relay contact (ground-in e.g. via the connections S1/S2) instead of via the internal transistor, then the internal quenching circuit has no effect! In this case, the customer must make sure that neither the relay contact nor the braking coil are damaged when switching off the brake. This can be done by interconnecting the coil or - better still - interconnecting the contact with a quenching circuit.

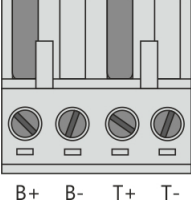
X4b	Pin	Name	Function
	1	T-	Temperature sensor -
	2	T+	Temperature sensor +
	3	B- <sup>1)</sup>	Brake -
	4	B+ <sup>1)</sup>	Brake +

Table 37: X4b connector - Pinout

- 1) If the holding brake is connected via an additional external relay contact (ground-in e.g. via the connections S1/S2) instead of via the internal transistor, then the internal quenching circuit has no effect! In this case, the customer must make sure that neither the relay contact nor the braking coil are damaged when switching off the brake. This can be done by interconnecting the coil or - better still - interconnecting the contact with a quenching circuit.

**Danger!**

The connections for the motor temperature sensors and the motor holding brake are isolated circuits. Therefore, these connections are only allowed to be connected to devices or components with at least safe isolation in accordance with IEC 60364-4-41 or EN 61800-5-1.

**Caution!**

If B+ and B- are swapped when connecting the permanent magnet holding brakes, then the brakes cannot be opened! ACOPOS servo drives cannot determine if a holding brake is connected with reverse polarity!

### 2.4.4.4.1 Wiring the connections for the motor holding brake

The supply, activation and monitoring of the output for the motor holding brake can take place via the X4a connector in three different ways:

	Figure	Description
1	<p>The diagram shows the internal monitoring circuit (I and U) connected to the X4a connector. The X4b connector is connected to the motor holding brake (B+ and B-). The supply and activation are internally provided by the ACOPOS servo drive.</p>	<ul style="list-style-type: none"> <li><b>Supply:</b> Internally by the ACOPOS servo drive</li> <li><b>Activation:</b> Internally by the ACOPOS servo drive</li> <li><b>Monitoring:</b> Internally by the ACOPOS servo drive</li> </ul> <p>A jumper must be placed between S1 and S2 as well as S3 and S4 on the X4a connector. <sup>1)</sup></p>
2	<p>The diagram shows the internal monitoring circuit (I and U) connected to the X4a connector. The X4b connector is connected to the motor holding brake (B+ and B-). The supply and activation are internally provided by the ACOPOS servo drive, while monitoring is external.</p>	<ul style="list-style-type: none"> <li><b>Supply:</b> Internally by the ACOPOS servo drive</li> <li><b>Activation:</b> Internally by the ACOPOS servo drive and also possible externally using potential-free contacts <sup>2)</sup></li> <li><b>Monitoring:</b> Internally by the ACOPOS servo drive</li> </ul> <p><b>Information:</b> The parameters for internal monitoring via the ACOPOS must be set according to the requirements of the application. <sup>3)</sup></p>
3	<p>The diagram shows the external monitoring circuit (I and U) connected to the X4a connector. The X4b connector is connected to the motor holding brake (B+ and B-). The supply and activation are external.</p>	<ul style="list-style-type: none"> <li><b>Supply:</b> External</li> <li><b>Activation:</b> External</li> <li><b>Monitoring:</b> External</li> </ul> <p><b>Information:</b> ACOPOS internal monitoring cannot be used here; therefore, it must be disabled using software. <sup>4)</sup></p>

Table 38: Activation for the external holding brake

- Both jumpers are already on the X4a connector delivered with the ACOPOS servo drives.
- External potential-free contacts can be connected between S1 and S2 as well as between S3 and S4. This makes it possible to activate the holding brake using an external safety circuit independent of the control integrated in the ACOPOS servo drive.
- The parameters are set using ParID 90 (1 ... internal monitoring active; 5 ... internal monitoring not active).
- Deactivation takes place using ParID 90 (5 ... internal monitoring not active).

### 2.4.4.5 X5 connector - Pinout

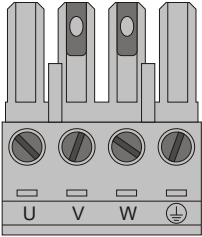
X5	Pin	Name	Function
	1	PE	Protective ground conductor
	2	W	Motor connection W
	3	V	Motor connection V
	4	U	Motor connection U
Terminal cross sections see "Overview of clampable cross sections" on page 245			

Table 39: X5 connector - Pinout

### 2.4.4.6 Additional protective ground connection (PE)

The protective ground conductor is connected to the M5 threaded bolt provided using a cable lug. For additional information regarding dimensioning, see "Protective ground connection (PE)" on page 204.

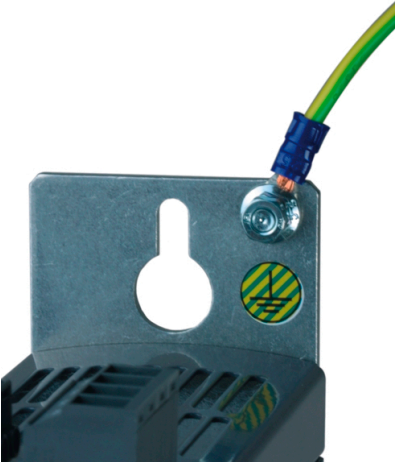
Figure	Pin	Name	Function					
	---	PE	Protective ground conductor					
	<table border="1"> <thead> <tr> <th>Terminal cross sections</th> <th>[mm<sup>2</sup>]</th> <th>AWG</th> </tr> </thead> <tbody> <tr> <td>Cable lug for M5 threaded bolt</td> <td>0.25 - 16</td> <td>23 - 5</td> </tr> </tbody> </table>			Terminal cross sections	[mm <sup>2</sup> ]	AWG	Cable lug for M5 threaded bolt	0.25 - 16
Terminal cross sections	[mm <sup>2</sup> ]	AWG						
Cable lug for M5 threaded bolt	0.25 - 16	23 - 5						

Table 40: Protective ground connection (PE) - ACOPOS

## Danger!

**Before turning on the servo drive, make sure that the housing is properly connected to ground (PE rail). The ground connection must be established even when testing the drive or operating it for a short time!**

### 2.4.4.7 Input/Output circuit diagram

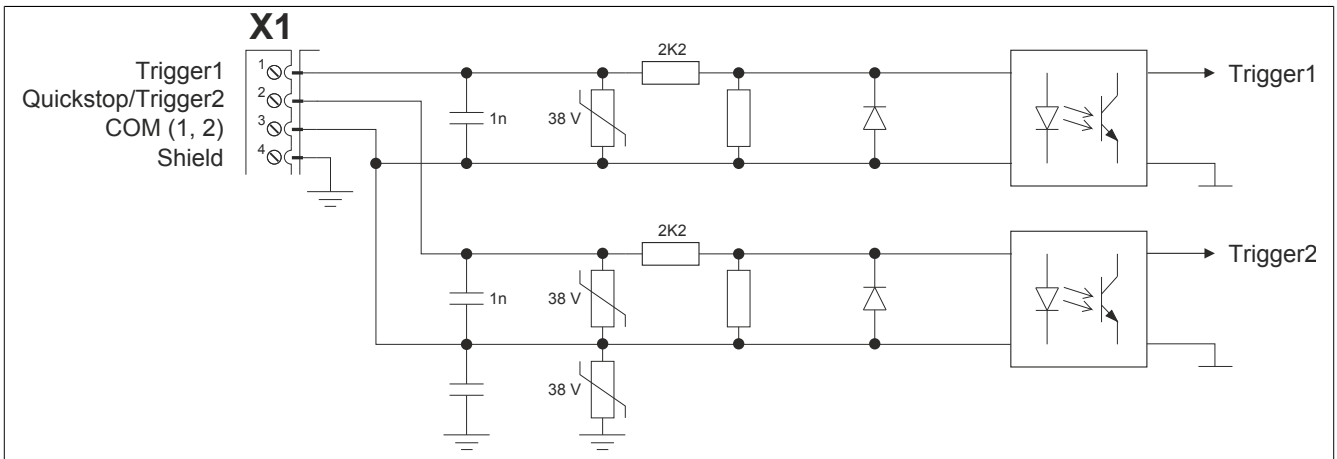


Figure 19: Trigger

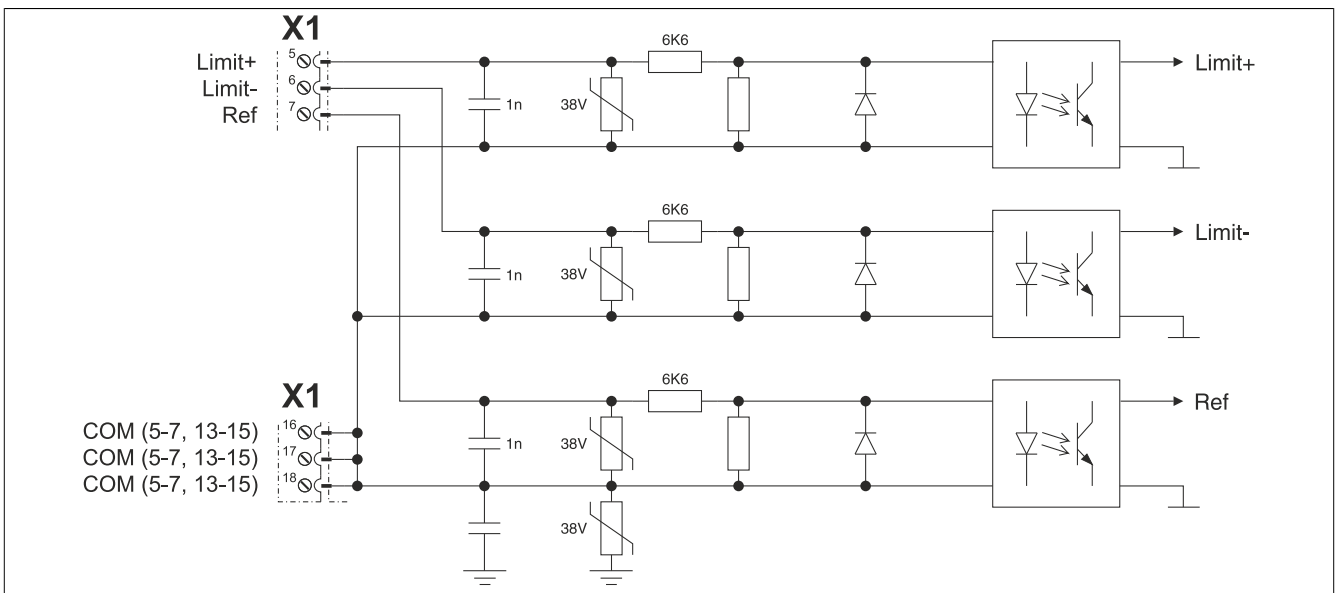


Figure 20: Limit

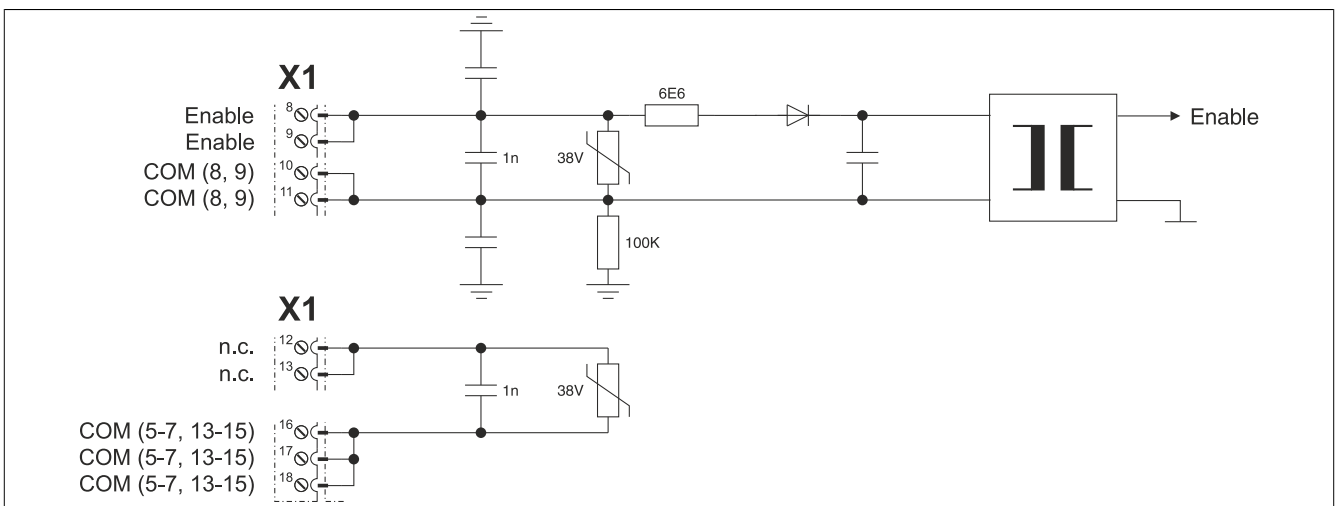


Figure 21: Enable

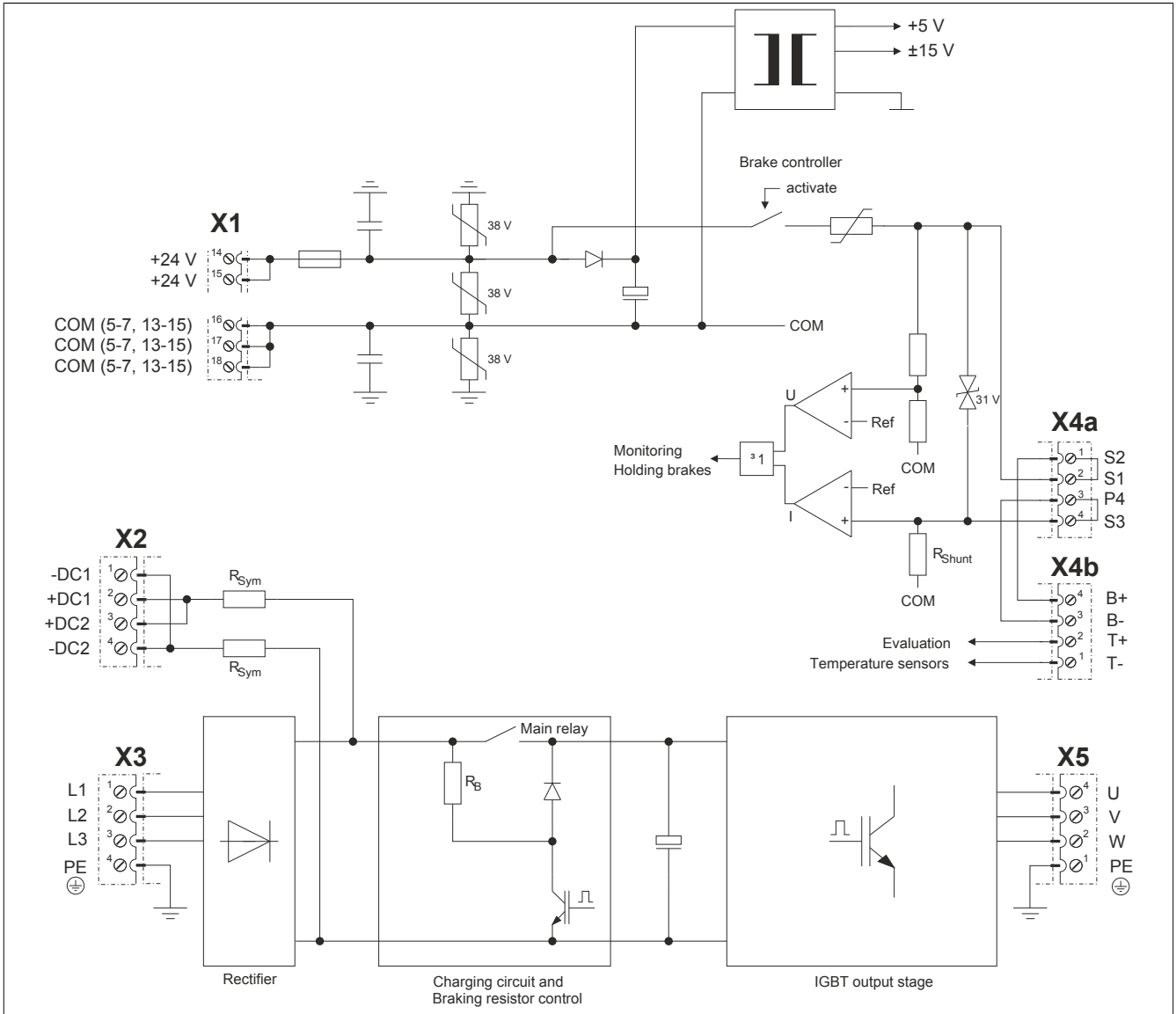


Figure 22: ACOPOS 1022, 1045, 1090 - Input/Output circuit diagram

## 2.5 ACOPOS 1180, 1320

### 2.5.1 ACOPOS 1180

#### 2.5.1.1 Order data


Model number	Short description	Figure
<b>Servo drives</b>		
8V1180.00-2	ACOPOS servo drive, 3x 400-480 V, 19 A, 9 kW, line filter, integrated braking resistor, DC bus power supply and electronic secure restart inhibit	
8V1180.001-2	ACOPOS servo drive, 3x 400-480 V, 19 A, 9 kW, coated, line filter, integrated braking resistor, DC bus power supply and electronic secure restart inhibit	
<b>Optional accessories</b>		
<b>Braking resistors</b>		
8B0W0045H000.000-1	ACOPOS multi braking resistor, 450 W, 50 R, IP20, terminals	
8B0W0045H000.001-1	ACOPOS multi braking resistor, 450 W, 50 R, IP65, terminals	
8B0W0079H000.000-1	ACOPOS multi braking resistor, 790 W, 33 R, IP20, terminals	
8B0W0079H000.001-1	ACOPOS multi braking resistor, 790 W, 33 R, IP65, terminals	
<b>Plug-in modules</b>		
8AC110.60-2	ACOPOS plug-in module, CAN interface	
8AC114.60-2	ACOPOS plug-in module, POWERLINK V2 interface	
8AC120.60-1	ACOPOS plug-in module, EnDat encoder and sine incremental encoder interface	
8AC121.60-1	ACOPOS plug-in module, HIPERFACE interface	
8AC122.60-3	ACOPOS plug-in module, resolver interface 10 kHz	
8AC123.60-1	ACOPOS plug-in module, incremental encoder and SSI absolute encoder interface	
8AC125.60-1	ACOPOS plug-in module, BiSS encoder interface 5 V	
8AC125.60-2	ACOPOS plug-in module, BiSS encoder interface 5V, baud rate 6.25 Mbit/s	
8AC125.61-2	ACOPOS plug-in module, BiSS encoder interface 12V, baud rate 6.25 Mbit/s	
8AC126.60-1	ACOPOS plug-in module, EnDat 2.2 encoder interface	
8AC130.60-1	ACOPOS plug-in module, 8 digital I/O configurable in pairs as 24 V input or as output 400/100 mA, 2 digital outputs 2 A, order TB712 terminal block separately.	
8AC131.60-1	ACOPOS plug-in module, 2 analog inputs $\pm 10$ V, 2 digital I/O points which can be configured as a 24 V input or 45 mA output, order TB712 terminal block separately.	
8AC132.60-1	ACOPOS plug-in module, 2 analog inputs $\pm 10$ V	
8AC140.60-3	ACOPOS plug-in module, CPU, x86 100 MHz Intel compatible, 32 MB DRAM, 32 kB SRAM, removable application memory: CompactFlash, 1 CAN interface, 1 Ethernet interface 100 Base-T, 1 PROFIBUS DP slave interface, 1 RS232 interface, 3 digital I/O can be configured as 24 VDC input or 500 mA output, 1 analog input $\pm 10$ V, order program memory and 0TB708 terminal block separately.	
8AC140.61-3	ACOPOS plug-in module, CPU, ARNC0, x86 100 MHz Intel compatible, 32 MB DRAM, 32 kB SRAM, removable application memory: CompactFlash, 1 CAN interface, 1 Ethernet interface 100 Base-T, 1 PROFIBUS DP slave interface, 1 RS232 interface, 3 digital I/O can be configured as 24 VDC input or 500 mA output, 1 analog input $\pm 10$ V, order program memory and 0TB708 terminal block separately.	
8AC141.60-2	ACOPOS plug-in module, CPU, x86 100 MHz Intel compatible, 16 MB DRAM, 32 kB SRAM, removable application memory: CompactFlash, 2 CAN interfaces, 1 Ethernet interface 100 Base-T, 1 RS232 interface, 1 X2X Link Master interface, 3 digital I/O can be configured as 24 VDC input or output 500 mA, 1 analog input $\pm 10$ V, order program memory and 0TB704 and 0TB708 terminal blocks separately	
8AC141.61-3	ACOPOS plug-in module, CPU, ARNC0, x86 100 MHz Intel compatible, 32 MB DRAM, 32 kB SRAM, removable application memory: CompactFlash, 2 CAN interfaces, 1 Ethernet interface 100 Base-T, 1 RS232 interface, 1 X2X Link Master interface, 3 digital I/O can be configured as 24 VDC input or output 500 mA, 1 analog input $\pm 10$ V, order program memory and 0TB704 and 0TB708 terminal blocks separately	
<b>Shielding component sets</b>		
8X0020.00-1	ACOPOS shielding components set for 8V1180.xxx-x and 8V1320.xxx-x	
<b>Terminal sets</b>		
8X0002.00-1	ACOPOS accessories, plug set for 8V1180.00 and 8V1320.00 (3 phase)	

Table 41: 8V1180.00-2, 8V1180.001-2 - Order data

## 2.5.1.2 Technical data

Product ID	8V1180.00-2	8V1180.001-2
<b>General information</b>		
B&R ID code	0x1282	0xA000
Slots for plug-in modules	4	
Certification c-UL-us	Yes	
<b>Power mains connection</b>		
Permissible power mains forms	TT, TN <sup>1)</sup>	
Mains input voltage	3x 400 VAC to 480 VAC ±10%	
Frequency	50 / 60 Hz ±4%	
Installed load	Max. 17 kVA	
Starting current at 400 VAC	13 A	
Switch-on interval	>10 s	
Integrated line filter in accordance with EN 61800-3, Category C3 <sup>2)</sup>	Yes	
Power loss at max. device power without braking resistor	Approx. 500 W	
<b>DC bus connection</b>		
DC bus capacitance	940 µF	
<b>24 VDC supply</b>		
Input voltage	24 VDC +25% / -20%	
Input capacitance	40000 µF	
Current requirements at 24 VDC <sup>3)</sup>		
Mains input voltage applied	- <sup>4)</sup>	
Mains input voltage not applied	Max. 2.8 A + current for the motor holding brake + current on the 24 VDC output	
DC bus power supply		
Switch-on voltage	455 VDC	
<b>24 VDC output</b>		
Output voltage		
Mains input voltage applied	22 to 24 VDC	
Mains input voltage not applied	16.7 to 30 VDC <sup>5)</sup>	
Output current	Max. 0.5 A	
<b>Motor connection</b>		
Quantity	1	
Continuous current <sup>6)</sup>	19 A <sub>eff</sub>	
Reduction of continuous current depending on the ambient temperature		
Mains input voltage: 400 VAC		
Switching frequency 5 kHz	No reduction	
Switching frequency 10 kHz	No reduction <sup>7)</sup>	
Switching frequency 20 kHz	No reduction	
Mains input voltage: 480 VAC		
Switching frequency 5 kHz	No reduction	
Switching frequency 10 kHz	No reduction <sup>7)</sup>	
Switching frequency 20 kHz	No reduction	
Reduction of continuous current depending on the altitude		
Starting at 500 m above sea level	1.9 A <sub>eff</sub> per 1000 m	
Peak current	50 A <sub>eff</sub>	
Nominal switching frequency	10 kHz	
Possible switching frequencies	5 / 10 / 20 kHz	
Electrical stress of the connected motor in accordance with IEC TS 60034-25	Limit value curve A	
Max. motor line length	25 m	
Protective measures		
Overload protection	Yes	
Short circuit and ground fault protection	Yes	
Max. output frequency	600 Hz <sup>8)</sup>	
<b>Motor holding brake connection</b>		
Max. output current	1.5 A	
Max. number of switching cycles	Unlimited since handled electronically	
<b>Braking resistors</b>		
Peak power int. / ext.	14 / 40 kW	
Continuous power int. / ext.	0.4 / 8 kW <sup>9)</sup>	
Minimum braking resistance (ext.)	15 Ω	
Rated current of the built-in fuse	12 A (fast-acting)	
<b>Limit switch and reference inputs</b>		
Quantity	3	
Wiring	Sink	
Electrical isolation		
Input - ACOPOS	Yes	
Input - Input	No	

Table 42: 8V1180.00-2, 8V1180.001-2 - Technical data

Product ID	8V1180.00-2	8V1180.001-2
Input voltage		
Nominal		24 VDC
Maximum		30 VDC
Switching threshold		
Low		<5 V
High		>15 V
Input current at nominal voltage		Approx. 4 mA
Switching delay		Max. 2.0 ms
Modulation compared to ground potential		Max. ±38 V
<b>Enable inputs</b>		
Quantity		1
Wiring		Sink
Electrical isolation		
Input - ACOPOS		Yes
Input voltage		
Nominal		24 VDC
Maximum		30 VDC
Input current at nominal voltage		Approx. 30 mA
Switching threshold		
Low		<5 V
High		>15 V
Switching delay		
Enable 0 -> 1, ready for PWM		Max. 100 µs
Enable 1 -> 0, PWM off		Max. 2.0 ms
Modulation compared to ground potential		Max. ±38 V
<b>Trigger inputs</b>		
Quantity		2
Wiring		Sink
Electrical isolation		
Input - ACOPOS		Yes
Input - Input		No
Input voltage		
Nominal		24 VDC
Maximum		30 VDC
Switching threshold		
Low		<5 V
High		>15 V
Input current at nominal voltage		Approx. 10 mA
Switching delay		
Positive edge		52 µs ±0.5 µs (digitally filtered)
Negative edge		53 µs ±0.5 µs (digitally filtered)
Modulation compared to ground potential		Max. ±38 V
<b>Operating conditions</b>		
Permitted mounting orientations		
Hanging vertically		Yes
Lying horizontally		Yes
Standing horizontally		No
Installation at altitudes above sea level		
Nominal		0 to 500 m
Maximum <sup>10)</sup>		2000 m
Degree of pollution in accordance with EN 60664-1		2 (non-conductive pollution)
Overvoltage category in accordance with IEC 60364-4-443:1999		II
EN 60529 protection		IP20
<b>Environmental conditions</b>		
Temperature		
Operation		
Nominal		5 to 40°C
Maximum <sup>11)</sup>		55°C
Storage		-25 to 55°C
Transport		-25 to 70°C
Relative humidity		
Operation		5 to 85%
Storage		5 to 95%
Transport		Max. 95% at 40°C
<b>Mechanical characteristics</b>		
Dimensions		
Width		200 mm
Height		375 mm
Depth		234 mm
Weight		10.1 kg

Table 42: 8V1180.00-2, 8V1180.001-2 - Technical data

- 1) In the USA, TT and TN power mains are commonly referred to as "Delta/Wye with grounded Wye neutral".
- 2) Limit values from CISPR11, group 2, class A (second environment).
- 3) The current requirements depend on the configuration of the ACOPOS servo drive.

- 4) If the mains input voltage (3x 400 VAC to 480 VAC  $\pm 10\%$ ) is applied, then the 24 VDC supply voltage for the ACOPOS servo drive is generated by the internal DC bus power supply, reducing the 24 VDC current consumption ( $I_{24\text{VDC}}$ ) to 0.
- 5) If the mains input voltage (3x 400 VAC to 480 VAC  $\pm 10\%$ ) is not applied, the voltage is generated at the 24 VDC output from the ACOPOS servo drive's 24 VDC supply voltage; in this case, it is between the maximum permissible and minimum permissible (reduced by max. 2.5 V) 24 VDC supply voltage of the ACOPOS servo drive.
- 6) Valid in the following conditions: 400 VAC mains input voltage, nominal switching frequency, 40°C ambient temperature, installation altitude <500 m above sea level.
- 7) Value for the nominal switching frequency.
- 8) The module's electrical output frequency (SCTRL\_SPEED\_ACT \* MOTOR\_POLEPAIRS) is monitored to protect against dual use in accordance with EC 428/2009 | 3A225. If the electrical output frequency of the module exceeds the limit value of 600 Hz uninterrupted for more than 0.5 s, then the current movement is aborted and error 6060 is output (power unit: limit speed exceeded).
- 9) Continuous power refers to the maximum braking power the ACOPOS servo drive can exchange continuously. Depending on the application, the actual continuous power provided by the external braking resistor is limited by the rated current of fuse  $I_b$  (integrated in the ACOPOS servo drive), and the value of the external braking resistance  $R_{BR}$ .
- 10) Continuous operation of ACOPOS servo drives at altitudes ranging from 500 m to 2000 m above sea level is possible (taking the specified continuous current reductions into consideration). Requirements that go above and beyond this need to be arranged with B&R.
- 11) Continuous operation of ACOPOS servo drives at ambient temperatures ranging from 40°C to max. 55°C is possible (taking the specified continuous current reductions into consideration), but this will result in a shorter service life.

## 2.5.2 ACOPOS 1320

### 2.5.2.1 Order data


Model number	Short description	Figure
8V1320.00-2	ACOPOS servo drive, 3x 400-480 V, 34 A, 16 kW, line filter, integrated braking resistor, DC bus power supply and electronic secure restart inhibit	
8V1320.001-2	ACOPOS servo drive, 3x 400-480 V, 34 A, 16 kW, coated, line filter, integrated braking resistor, DC bus power supply and electronic secure restart inhibit	
<b>Optional accessories</b>		
<b>Braking resistors</b>		
8B0W0045H000.000-1	ACOPOS multi braking resistor, 450 W, 50 R, IP20, terminals	
8B0W0045H000.001-1	ACOPOS multi braking resistor, 450 W, 50 R, IP65, terminals	
8B0W0079H000.000-1	ACOPOS multi braking resistor, 790 W, 33 R, IP20, terminals	
8B0W0079H000.001-1	ACOPOS multi braking resistor, 790 W, 33 R, IP65, terminals	
<b>Plug-in modules</b>		
8AC110.60-2	ACOPOS plug-in module, CAN interface	
8AC114.60-2	ACOPOS plug-in module, POWERLINK V2 interface	
8AC120.60-1	ACOPOS plug-in module, EnDat encoder and sine incremental encoder interface	
8AC121.60-1	ACOPOS plug-in module, HIPERFACE interface	
8AC122.60-3	ACOPOS plug-in module, resolver interface 10 kHz	
8AC123.60-1	ACOPOS plug-in module, incremental encoder and SSI absolute encoder interface	
8AC125.60-1	ACOPOS plug-in module, BiSS encoder interface 5 V	
8AC125.60-2	ACOPOS plug-in module, BiSS encoder interface 5V, baud rate 6.25 Mbit/s	
8AC125.61-2	ACOPOS plug-in module, BiSS encoder interface 12V, baud rate 6.25 Mbit/s	
8AC126.60-1	ACOPOS plug-in module, EnDat 2.2 encoder interface	
8AC130.60-1	ACOPOS plug-in module, 8 digital I/O configurable in pairs as 24 V input or as output 400/100 mA, 2 digital outputs 2 A, order TB712 terminal block separately.	
8AC131.60-1	ACOPOS plug-in module, 2 analog inputs $\pm 10$ V, 2 digital I/O points which can be configured as a 24 V input or 45 mA output, order TB712 terminal block separately.	
8AC132.60-1	ACOPOS plug-in module, 2 analog inputs $\pm 10$ V	
8AC140.60-3	ACOPOS plug-in module, CPU, x86 100 MHz Intel compatible, 32 MB DRAM, 32 kB SRAM, removable application memory: CompactFlash, 1 CAN interface, 1 Ethernet interface 100 Base-T, 1 PROFIBUS DP slave interface, 1 RS232 interface, 3 digital I/O can be configured as 24 VDC input or 500 mA output, 1 analog input $\pm 10$ V, order program memory and 0TB708 terminal block separately.	
8AC140.61-3	ACOPOS plug-in module, CPU, ARNC0, x86 100 MHz Intel compatible, 32 MB DRAM, 32 kB SRAM, removable application memory: CompactFlash, 1 CAN interface, 1 Ethernet interface 100 Base-T, 1 PROFIBUS DP slave interface, 1 RS232 interface, 3 digital I/O can be configured as 24 VDC input or 500 mA output, 1 analog input $\pm 10$ V, order program memory and 0TB708 terminal block separately.	
8AC141.60-2	ACOPOS plug-in module, CPU, x86 100 MHz Intel compatible, 16 MB DRAM, 32 kB SRAM, removable application memory: CompactFlash, 2 CAN interfaces, 1 Ethernet interface 100 Base-T, 1 RS232 interface, 1 X2X Link Master interface, 3 digital I/O can be configured as 24 VDC input or output 500 mA, 1 analog input $\pm 10$ V, order program memory and 0TB704 and 0TB708 terminal blocks separately	
8AC141.61-3	ACOPOS plug-in module, CPU, ARNC0, x86 100 MHz Intel compatible, 32 MB DRAM, 32 kB SRAM, removable application memory: CompactFlash, 2 CAN interfaces, 1 Ethernet interface 100 Base-T, 1 RS232 interface, 1 X2X Link Master interface, 3 digital I/O can be configured as 24 VDC input or output 500 mA, 1 analog input $\pm 10$ V, order program memory and 0TB704 and 0TB708 terminal blocks separately	
<b>Shielding component sets</b>		
8X0020.00-1	ACOPOS shielding components set for 8V1180.xxx-x and 8V1320.xxx-x	
<b>Terminal sets</b>		
8X0002.00-1	ACOPOS accessories, plug set for 8V1180.00 and 8V1320.00 (3 phase)	

Table 43: 8V1320.00-2, 8V1320.001-2 - Order data

## 2.5.2.2 Technical data

Product ID	8V1320.00-2	8V1320.001-2
<b>General information</b>		
B&R ID code	0x1283	0xA001
Slots for plug-in modules	4	
Certification c-UL-us	Yes	
<b>Power mains connection</b>		
Permissible power mains forms	TT, TN <sup>1)</sup>	
Mains input voltage	3x 400 VAC to 480 VAC ±10%	
Frequency	50 / 60 Hz ±4%	
Installed load	Max. 30 kVA	
Starting current at 400 VAC	13 A	
Switch-on interval	>10 s	
Integrated line filter in accordance with EN 61800-3, Category C3 <sup>2)</sup>	Yes	
Power loss at max. device power without braking resistor	Approx. 800 W	
<b>DC bus connection</b>		
DC bus capacitance	1645 µF	
<b>24 VDC supply</b>		
Input voltage	24 VDC +25% / -20%	
Input capacitance	40000 µF	
Current requirements at 24 VDC <sup>3)</sup>		
Mains input voltage applied	- <sup>4)</sup>	
Mains input voltage not applied	Max. 2.8 A + current for the motor holding brake + current on the 24 VDC output	
DC bus power supply		
Switch-on voltage	455 VDC	
<b>24 VDC output</b>		
Output voltage		
Mains input voltage applied	22 to 24 VDC	
Mains input voltage not applied	16.7 to 30 VDC <sup>5)</sup>	
Output current	Max. 0.5 A	
<b>Motor connection</b>		
Quantity	1	
Continuous current <sup>6)</sup>	34 A <sub>eff</sub>	
Reduction of continuous current depending on the ambient temperature		
Mains input voltage: 400 VAC		
Switching frequency 5 kHz	No reduction	
Switching frequency 10 kHz	No reduction <sup>7)</sup>	
Switching frequency 20 kHz	0.61 A <sub>eff</sub> per °C (starting at 40°C)	
Mains input voltage: 480 VAC		
Switching frequency 5 kHz	No reduction	
Switching frequency 10 kHz	No reduction <sup>7)</sup>	
Switching frequency 20 kHz	0.61 A <sub>eff</sub> per °C (starting at 25°C)	
Reduction of continuous current depending on the altitude		
Starting at 500 m above sea level	3.4 A <sub>eff</sub> per 1000 m	
Peak current	80 A <sub>eff</sub>	
Nominal switching frequency	10 kHz	
Possible switching frequencies	5 / 10 / 20 kHz	
Electrical stress of the connected motor in accordance with IEC TS 60034-25	Limit value curve A	
Max. motor line length	25 m	
Protective measures		
Overload protection	Yes	
Short circuit and ground fault protection	Yes	
Max. output frequency	600 Hz <sup>8)</sup>	
<b>Motor holding brake connection</b>		
Max. output current	1.5 A	
Max. number of switching cycles	Unlimited since handled electronically	
<b>Braking resistors</b>		
Peak power int. / ext.	14 / 40 kW	
Continuous power int. / ext.	0.4 / 8 kW <sup>9)</sup>	
Minimum braking resistance (ext.)	15 Ω	
Rated current of the built-in fuse	12 A (fast-acting)	
<b>Limit switch and reference inputs</b>		
Quantity	3	
Wiring	Sink	
Electrical isolation		
Input - ACOPOS	Yes	
Input - Input	No	

Table 44: 8V1320.00-2, 8V1320.001-2 - Technical data

Product ID	8V1320.00-2	8V1320.001-2
Input voltage		
Nominal		24 VDC
Maximum		30 VDC
Switching threshold		
Low		<5 V
High		>15 V
Input current at nominal voltage		Approx. 4 mA
Switching delay		Max. 2.0 ms
Modulation compared to ground potential		Max. ±38 V
<b>Enable inputs</b>		
Quantity		1
Wiring		Sink
Electrical isolation		
Input - ACOPOS		Yes
Input voltage		
Nominal		24 VDC
Maximum		30 VDC
Input current at nominal voltage		Approx. 30 mA
Switching threshold		
Low		<5 V
High		>15 V
Switching delay		
Enable 0 -> 1, ready for PWM		Max. 100 µs
Enable 1 -> 0, PWM off		Max. 2.0 ms
Modulation compared to ground potential		Max. ±38 V
<b>Trigger inputs</b>		
Quantity		2
Wiring		Sink
Electrical isolation		
Input - ACOPOS		Yes
Input - Input		No
Input voltage		
Nominal		24 VDC
Maximum		30 VDC
Switching threshold		
Low		<5 V
High		>15 V
Input current at nominal voltage		Approx. 10 mA
Switching delay		
Positive edge		52 µs ±0.5 µs (digitally filtered)
Negative edge		53 µs ±0.5 µs (digitally filtered)
Modulation compared to ground potential		Max. ±38 V
<b>Operating conditions</b>		
Permitted mounting orientations		
Hanging vertically		Yes
Lying horizontally		Yes
Standing horizontally		No
Installation at altitudes above sea level		
Nominal		0 to 500 m
Maximum <sup>10)</sup>		2000 m
Degree of pollution in accordance with EN 60664-1		2 (non-conductive pollution)
Overvoltage category in accordance with IEC 60364-4-443:1999		II
EN 60529 protection		IP20
<b>Environmental conditions</b>		
Temperature		
Operation		
Nominal		5 to 40°C
Maximum <sup>11)</sup>		55°C
Storage		-25 to 55°C
Transport		-25 to 70°C
Relative humidity		
Operation		5 to 85%
Storage		5 to 95%
Transport		Max. 95% at 40°C
<b>Mechanical characteristics</b>		
Dimensions		
Width		200 mm
Height		375 mm
Depth		234 mm
Weight		10.6 kg

Table 44: 8V1320.00-2, 8V1320.001-2 - Technical data

- 1) In the USA, TT and TN power mains are commonly referred to as "Delta/Wye with grounded Wye neutral".
- 2) Limit values from CISPR11, group 2, class A (second environment).
- 3) The current requirements depend on the configuration of the ACOPOS servo drive.

- 4) If the mains input voltage (3x 400 VAC to 480 VAC  $\pm 10\%$ ) is applied, then the 24 VDC supply voltage for the ACOPOS servo drive is generated by the internal DC bus power supply, reducing the 24 VDC current consumption ( $I_{24\text{VDC}}$ ) to 0.
- 5) If the mains input voltage (3x 400 VAC to 480 VAC  $\pm 10\%$ ) is not applied, the voltage is generated at the 24 VDC output from the ACOPOS servo drive's 24 VDC supply voltage; in this case, it is between the maximum permissible and minimum permissible (reduced by max. 2.5 V) 24 VDC supply voltage of the ACOPOS servo drive.
- 6) Valid in the following conditions: 400 VAC mains input voltage, nominal switching frequency, 40°C ambient temperature, installation altitude <500 m above sea level.
- 7) Value for the nominal switching frequency.
- 8) The module's electrical output frequency (SCTRL\_SPEED\_ACT \* MOTOR\_POLEPAIRS) is monitored to protect against dual use in accordance with EC 428/2009 | 3A225. If the electrical output frequency of the module exceeds the limit value of 600 Hz uninterrupted for more than 0.5 s, then the current movement is aborted and error 6060 is output (power unit: limit speed exceeded).
- 9) Continuous power refers to the maximum braking power the ACOPOS servo drive can exchange continuously. Depending on the application, the actual continuous power provided by the external braking resistor is limited by the rated current of fuse  $I_b$  (integrated in the ACOPOS servo drive), and the value of the external braking resistance  $R_{BR}$ .
- 10) Continuous operation of ACOPOS servo drives at altitudes ranging from 500 m to 2000 m above sea level is possible (taking the specified continuous current reductions into consideration). Requirements that go above and beyond this need to be arranged with B&R.
- 11) Continuous operation of ACOPOS servo drives at ambient temperatures ranging from 40°C to max. 55°C is possible (taking the specified continuous current reductions into consideration), but this will result in a shorter service life.

### 2.5.3 Wiring

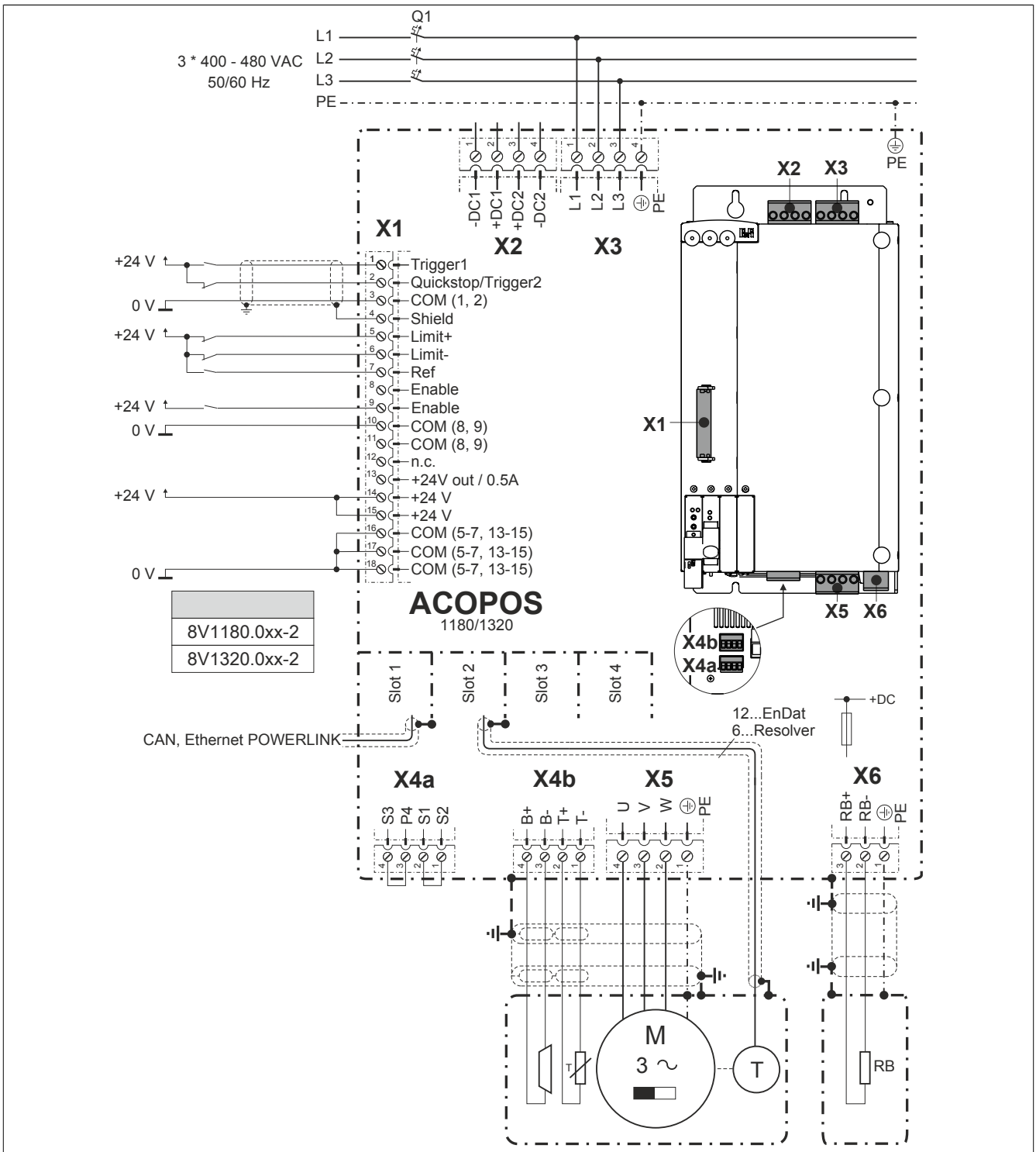


Figure 23: ACOPOS 1180, 1320 - Pinout overview

### 2.5.3.1 X1 connector - Pinout

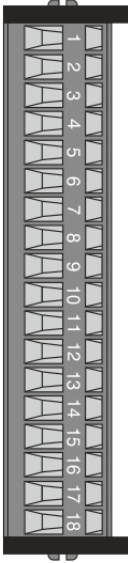
X1	Pin	Name	Function
	1	Trigger1	Trigger 1
	2	Quickstop/Trigger2	Quickstop/Trigger2
	3	COM (1, 2)	Trigger 1, Quickstop/Trigger 2 0 V
	4	Shield	Shield
	5	Limit+	Positive HW limit
	6	Limit-	Negative HW limit
	7	Ref	Reference switch
	8	Enable <sup>1)</sup>	Enable
	9	Enable <sup>1)</sup>	Enable
	10	COM (8, 9)	Enable 0 V
	11	COM (8, 9)	Enable 0 V
	12	---	---
	13	+24V out / 0.5A	+24 V output / 0.5 A
	14	+24 V	+24 V supply
	15	+24 V	+24 V supply
	16	COM (5-7, 13-15)	0 V supply
	17	COM (5-7, 13-15)	0 V supply
	18	COM (5-7, 13-15)	0 V supply
The following connections are linked with each other internally in the device: <ul style="list-style-type: none"> <li>• Pin 8 --&gt; Pin 9 (Enable)</li> <li>• Pin 10 --&gt; Pin 11 (Enable 0 V)</li> <li>• Pin 14 --&gt; Pin 15 (Supply +24 V)</li> <li>• Pin 16 --&gt; Pin 17 --&gt; Pin 18 (Supply 0 V)</li> </ul> Terminal cross sections see "Overview of clampable cross sections" on page 245			

Table 45: X1 connector - Pinout

1) The wiring is not permitted to exceed a total length of 30 m.

### 2.5.3.2 X2 connector - Pinout

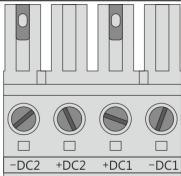
X2	Pin	Name	Function
	1	-DC1	U DC bus -
	2	+DC1	U DC bus +
	3	+DC2	U DC bus +
	4	-DC2	U DC bus -
Terminal cross sections see "Overview of clampable cross sections" on page 245			

Table 46: X2 connector - Pinout

### 2.5.3.3 X3 connector - Pinout

## Danger!

**Servo drives are not permitted to be operated directly on IT and TN-S mains with a grounded phase conductor and protective ground conductor!**

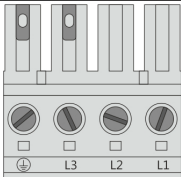
X3	Pin	Name	Function
	1	L1	Power mains connection L1
	2	L2	Power mains connection L2
	3	L3	Power mains connection L3
	4	PE	Protective ground conductor
Terminal cross sections see "Overview of clampable cross sections" on page 245			

Table 47: X3 connector - Pinout

## 2.5.3.4 X4a, X4b connectors - Pinout

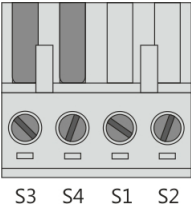
X4a	Pin	Name	Function
	1	S2 <sup>1)</sup>	Activation, supply for the external holding brake (+)
	2	S1 <sup>1)</sup>	Activation for the external holding brake (+)
	3	P4	Activation, supply for the external holding brake (-)
	4	S3	Activation for the external holding brake (-)
	Terminal cross sections see "Overview of clampable cross sections" on page 245		

Table 48: X4a connector - Pinout

- 1) If the holding brake is connected via an additional external relay contact (ground-in e.g. via the connections S1/S2) instead of via the internal transistor, then the internal quenching circuit has no effect! In this case, the customer must make sure that neither the relay contact nor the braking coil are damaged when switching off the brake. This can be done by interconnecting the coil or - better still - interconnecting the contact with a quenching circuit.

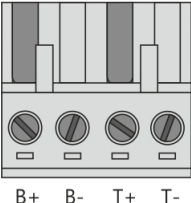
X4b	Pin	Name	Function
	1	T-	Temperature sensor -
	2	T+	Temperature sensor +
	3	B- <sup>1)</sup>	Brake -
	4	B+ <sup>1)</sup>	Brake +

Table 49: X4b connector - Pinout

- 1) If the holding brake is connected via an additional external relay contact (ground-in e.g. via the connections S1/S2) instead of via the internal transistor, then the internal quenching circuit has no effect! In this case, the customer must make sure that neither the relay contact nor the braking coil are damaged when switching off the brake. This can be done by interconnecting the coil or - better still - interconnecting the contact with a quenching circuit.

## Danger!

The connections for the motor temperature sensors and the motor holding brake are isolated circuits. Therefore, these connections are only allowed to be connected to devices or components with at least safe isolation in accordance with IEC 60364-4-41 or EN 61800-5-1.

## Caution!

If B+ and B- are swapped when connecting the permanent magnet holding brakes, then the brakes cannot be opened! ACOPOS servo drives cannot determine if a holding brake is connected with reverse polarity!

### 2.5.3.4.1 Wiring the connections for the motor holding brake

The supply, activation and monitoring of the output for the motor holding brake can take place via the X4a connector in three different ways:

	Figure	Description
1		<ul style="list-style-type: none"> <li>• <b>Supply:</b> Internally by the ACOPOS servo drive</li> <li>• <b>Activation:</b> Internally by the ACOPOS servo drive</li> <li>• <b>Monitoring:</b> Internally by the ACOPOS servo drive</li> </ul> <p>A jumper must be placed between S1 and S2 as well as S3 and S4 on the X4a connector. <sup>1)</sup></p>
2		<ul style="list-style-type: none"> <li>• <b>Supply:</b> Internally by the ACOPOS servo drive</li> <li>• <b>Activation:</b> Internally by the ACOPOS servo drive and also possible externally using potential-free contacts <sup>2)</sup></li> <li>• <b>Monitoring:</b> Internally by the ACOPOS servo drive</li> </ul> <p><b>Information:</b> The parameters for internal monitoring via the ACOPOS must be set according to the requirements of the application. <sup>3)</sup></p>
3		<ul style="list-style-type: none"> <li>• <b>Supply:</b> External</li> <li>• <b>Activation:</b> External</li> <li>• <b>Monitoring:</b> External</li> </ul> <p><b>Information:</b> ACOPOS internal monitoring cannot be used here; therefore, it must be disabled using software. <sup>4)</sup></p>

Table 50: Activation for the external holding brake

- 1) Both jumpers are already on the X4a connector delivered with the ACOPOS servo drives.
- 2) External potential-free contacts can be connected between S1 and S2 as well as between S3 and S4. This makes it possible to activate the holding brake using an external safety circuit independent of the control integrated in the ACOPOS servo drive.
- 3) The parameters are set using ParID 90 (1 ... internal monitoring active; 5 ... internal monitoring not active).
- 4) Deactivation takes place using ParID 90 (5 ... internal monitoring not active).

### 2.5.3.5 X5 connector - Pinout

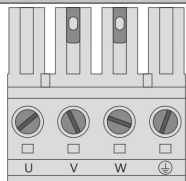
X5	Pin	Name	Function
	1	PE	Protective ground conductor
	2	W	Motor connection W
	3	V	Motor connection V
	4	U	Motor connection U
Terminal cross sections see "Overview of clampable cross sections" on page 245			

Table 51: X5 connector - Pinout

### 2.5.3.6 X6 connector - Pinout

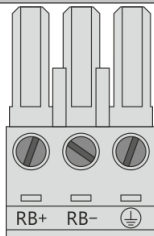
X6	Pin	Name	Function
	1	PE	Protective ground conductor
	2	RB-	Braking resistor -
	3	RB+	Braking resistor +
Terminal cross sections see "Overview of clampable cross sections" on page 245			

Table 52: X6 connector - Pinout

### 2.5.3.7 Additional protective ground connection (PE)

The protective ground conductor is connected to the M5 threaded bolt provided using a cable lug.

For additional information regarding dimensioning, see "Protective ground connection (PE)" on page 204.


Figure	Pin	Name	Function					
	---	PE	Protective ground conductor					
	<table border="1" style="width: 100%; border-collapse: collapse;"> <thead> <tr> <th style="text-align: left;">Terminal cross sections</th> <th style="text-align: center;">[mm<sup>2</sup>]</th> <th style="text-align: center;">AWG</th> </tr> </thead> <tbody> <tr> <td>Cable lug for M5 threaded bolt</td> <td style="text-align: center;">0.25 - 16</td> <td style="text-align: center;">23 - 5</td> </tr> </tbody> </table>			Terminal cross sections	[mm <sup>2</sup> ]	AWG	Cable lug for M5 threaded bolt	0.25 - 16
Terminal cross sections	[mm <sup>2</sup> ]	AWG						
Cable lug for M5 threaded bolt	0.25 - 16	23 - 5						

Table 53: Protective ground connection (PE) - ACOPOS

## Danger!

**Before turning on the servo drive, make sure that the housing is properly connected to ground (PE rail). The ground connection must be established even when testing the drive or operating it for a short time!**

2.5.3.8 Input/Output circuit diagram

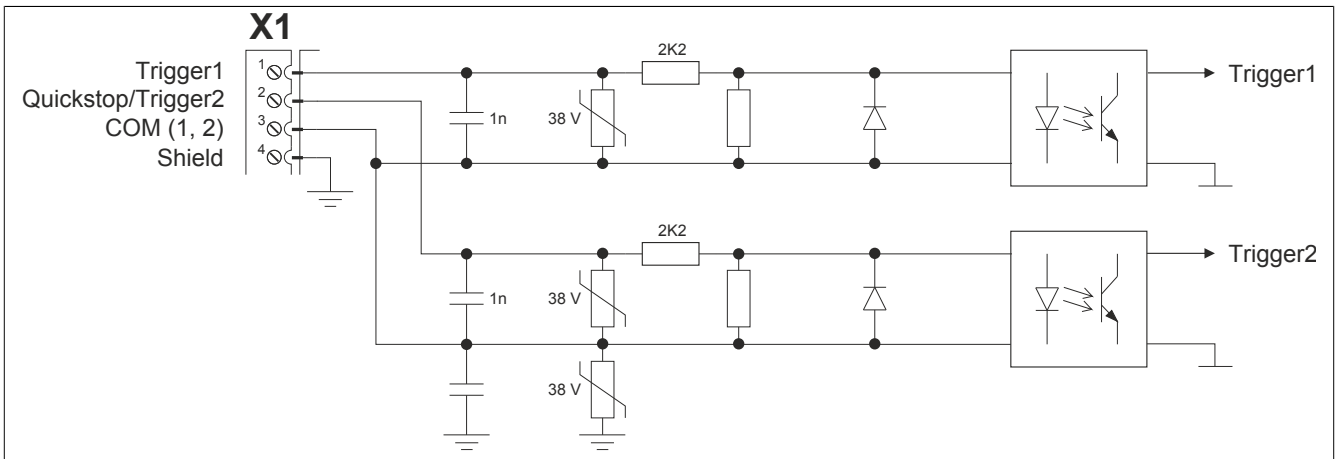


Figure 24: Trigger

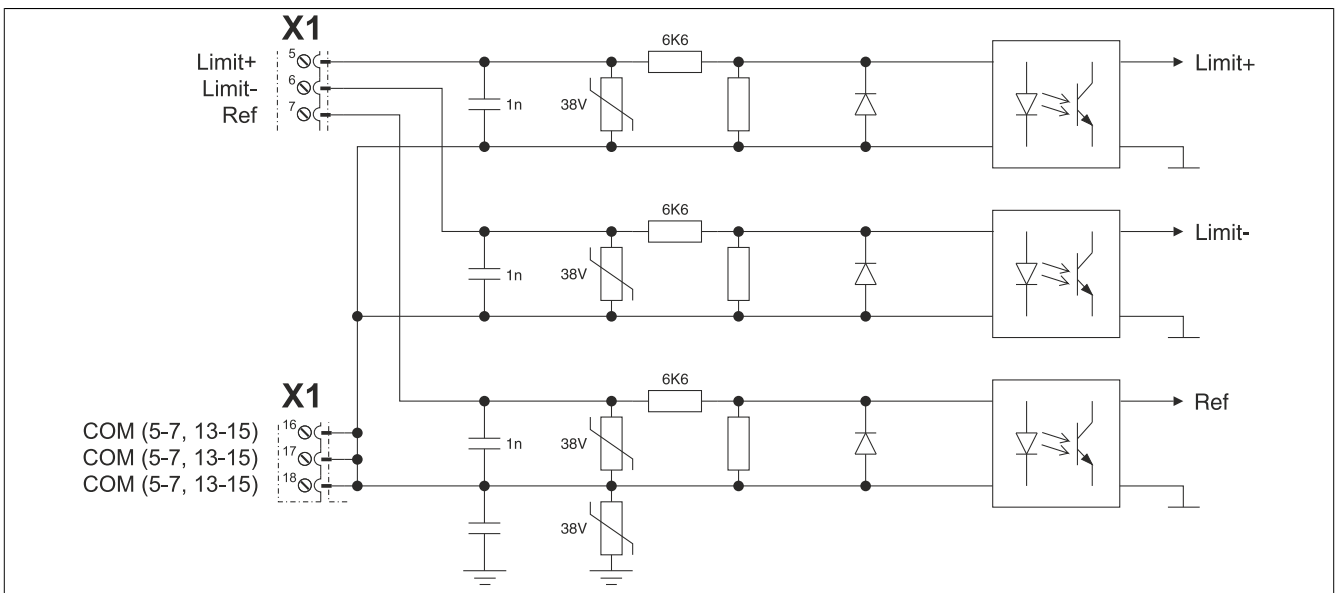


Figure 25: Limit

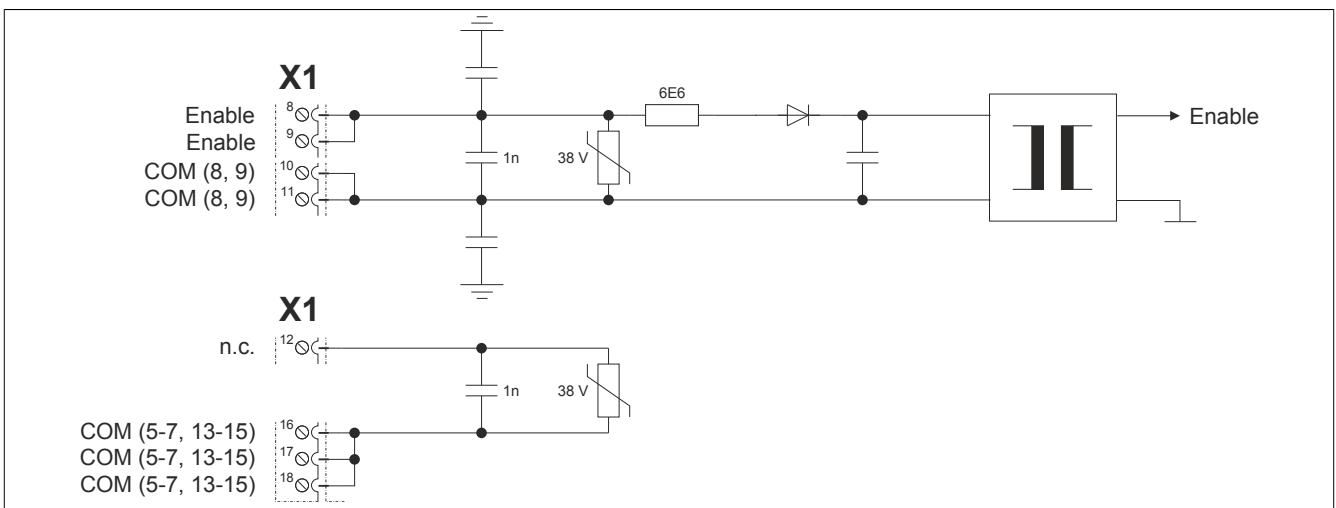


Figure 26: Enable

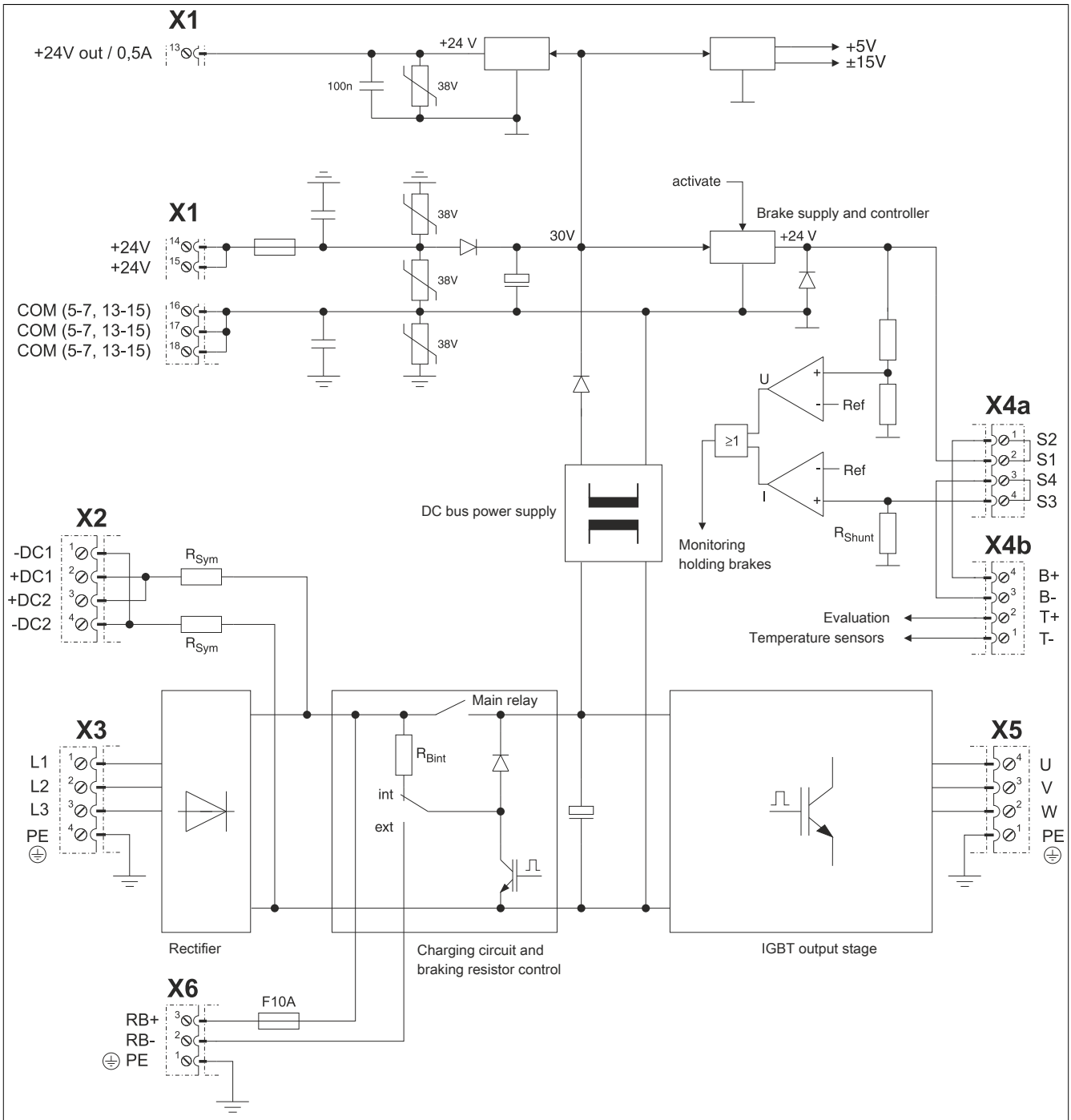


Figure 27: ACOPOS 1180, 1320 - Input/Output circuit diagram

## 2.6 ACOPOS 1640, 128M

### 2.6.1 ACOPOS 1640

#### 2.6.1.1 Order data

Model number	Short description	Figure
<b>Servo drives</b>		
8V1640.00-2	ACOPOS servo drive, 3x 400-480 V, 64 A, 32 kW, line filter, integrated braking resistor, DC bus power supply and electronic secure restart inhibit	
8V1640.001-2	ACOPOS servo drive, 3x 400-480 V, 64 A, 32 kW, coated, line filter, integrated braking resistor, DC bus power supply and electronic secure restart inhibit	
<b>Optional accessories</b>		
<b>Braking resistors</b>		
8B0W0045H000.000-1	ACOPOS multi braking resistor, 450 W, 50 R, IP20, terminals	
8B0W0045H000.001-1	ACOPOS multi braking resistor, 450 W, 50 R, IP65, terminals	
8B0W0079H000.000-1	ACOPOS multi braking resistor, 790 W, 33 R, IP20, terminals	
8B0W0079H000.001-1	ACOPOS multi braking resistor, 790 W, 33 R, IP65, terminals	
<b>Plug-in modules</b>		
8AC110.60-2	ACOPOS plug-in module, CAN interface	
8AC114.60-2	ACOPOS plug-in module, POWERLINK V2 interface	
8AC120.60-1	ACOPOS plug-in module, EnDat encoder and sine incremental encoder interface	
8AC121.60-1	ACOPOS plug-in module, HIPERFACE interface	
8AC122.60-3	ACOPOS plug-in module, resolver interface 10 kHz	
8AC123.60-1	ACOPOS plug-in module, incremental encoder and SSI absolute encoder interface	
8AC125.60-1	ACOPOS plug-in module, BiSS encoder interface 5 V	
8AC125.60-2	ACOPOS plug-in module, BiSS encoder interface 5V, baud rate 6.25 Mbit/s	
8AC125.61-2	ACOPOS plug-in module, BiSS encoder interface 12V, baud rate 6.25 Mbit/s	
8AC126.60-1	ACOPOS plug-in module, EnDat 2.2 encoder interface	
8AC130.60-1	ACOPOS plug-in module, 8 digital I/O configurable in pairs as 24 V input or as output 400/100 mA, 2 digital outputs 2 A, order TB712 terminal block separately.	
8AC131.60-1	ACOPOS plug-in module, 2 analog inputs $\pm 10$ V, 2 digital I/O points which can be configured as a 24 V input or 45 mA output, order TB712 terminal block separately.	
8AC132.60-1	ACOPOS plug-in module, 2 analog inputs $\pm 10$ V	
8AC140.60-3	ACOPOS plug-in module, CPU, x86 100 MHz Intel compatible, 32 MB DRAM, 32 kB SRAM, removable application memory: CompactFlash, 1 CAN interface, 1 Ethernet interface 100 Base-T, 1 PROFIBUS DP slave interface, 1 RS232 interface, 3 digital I/O can be configured as 24 VDC input or 500 mA output, 1 analog input $\pm 10$ V, order program memory and 0TB708 terminal block separately.	
8AC140.61-3	ACOPOS plug-in module, CPU, ARNC0, x86 100 MHz Intel compatible, 32 MB DRAM, 32 kB SRAM, removable application memory: CompactFlash, 1 CAN interface, 1 Ethernet interface 100 Base-T, 1 PROFIBUS DP slave interface, 1 RS232 interface, 3 digital I/O can be configured as 24 VDC input or 500 mA output, 1 analog input $\pm 10$ V, order program memory and 0TB708 terminal block separately.	
8AC141.60-2	ACOPOS plug-in module, CPU, x86 100 MHz Intel compatible, 16 MB DRAM, 32 kB SRAM, removable application memory: CompactFlash, 2 CAN interfaces, 1 Ethernet interface 100 Base-T, 1 RS232 interface, 1 X2X Link Master interface, 3 digital I/O can be configured as 24 VDC input or output 500 mA, 1 analog input $\pm 10$ V, order program memory and 0TB704 and 0TB708 terminal blocks separately	
8AC141.61-3	ACOPOS plug-in module, CPU, ARNC0, x86 100 MHz Intel compatible, 32 MB DRAM, 32 kB SRAM, removable application memory: CompactFlash, 2 CAN interfaces, 1 Ethernet interface 100 Base-T, 1 RS232 interface, 1 X2X Link Master interface, 3 digital I/O can be configured as 24 VDC input or output 500 mA, 1 analog input $\pm 10$ V, order program memory and 0TB704 and 0TB708 terminal blocks separately	
<b>Shielding component sets</b>		
8X0030.00-1	ACOPOS shielding components set for 8V1640.xxx-x and 8V128M.xxx-x	
<b>Terminal sets</b>		
8X0005.00-1	ACOPOS accessories, plug set for 8V1640.00 and 8V128M.00 (3 phase)	

Table 54: 8V1640.00-2, 8V1640.001-2 - Order data

## 2.6.1.2 Technical data

Product ID	8V1640.00-2	8V1640.001-2
<b>General information</b>		
B&R ID code	0x12C9	0xA09C
Slots for plug-in modules	4	
Certification c-UL-us	Yes	
<b>Power mains connection</b>		
Permissible power mains forms	TT, TN <sup>1)</sup>	
Mains input voltage	3x 400 VAC to 480 VAC ±10%	
Frequency	50 / 60 Hz ±4%	
Installed load	Max. 54 kVA	
Starting current at 400 VAC	26 A	
Switch-on interval	>10 s	
Integrated line filter in accordance with EN 61800-3, Category C3 <sup>2)</sup>	Yes	
Power loss at max. device power without braking resistor	Approx. 1600 W	
<b>DC bus connection</b>		
DC bus capacitance	3300 µF	
<b>24 VDC supply</b>		
Input voltage	24 VDC +25% / -20%	
Input capacitance	32800 µF	
Current requirements at 24 VDC <sup>3)</sup>		
Mains input voltage applied	- <sup>4)</sup>	
Mains input voltage not applied	Max. 4.6 A + 1.4 * (current for the motor holding brake + current on the 24 VDC output)	
DC bus power supply Switch-on voltage	455 VDC	
<b>24 VDC output</b>		
Output voltage		
Mains input voltage applied	22 to 24 VDC	
Mains input voltage not applied	16.7 to 30 VDC <sup>5)</sup>	
Output current	Max. 0.5 A	
<b>Motor connection</b>		
Quantity	1	
Continuous current <sup>6)</sup>	64 A <sub>eff</sub>	
Reduction of continuous current depending on the ambient temperature		
Mains input voltage: 400 VAC		
Switching frequency 5 kHz	No reduction	
Switching frequency 10 kHz	No reduction <sup>7)</sup>	
Switching frequency 20 kHz	0.96 A <sub>eff</sub> per °C (starting at 25°C)	
Mains input voltage: 480 VAC		
Switching frequency 5 kHz	No reduction	
Switching frequency 10 kHz	0.96 A <sub>eff</sub> per °C (starting at 50°C) <sup>7)</sup>	
Switching frequency 20 kHz	0.96 A <sub>eff</sub> per °C (starting at 10°C)	
Reduction of continuous current depending on the altitude		
Starting at 500 m above sea level	6.4 A <sub>eff</sub> per 1000 m	
Peak current	200 A <sub>eff</sub>	
Nominal switching frequency	10 kHz	
Possible switching frequencies	5 / 10 / 20 kHz	
Electrical stress of the connected motor in accordance with IEC TS 60034-25	Limit value curve A	
Max. motor line length	25 m	
Protective measures		
Overload protection	Yes	
Short circuit and ground fault protection	Yes	
Max. output frequency	600 Hz <sup>8)</sup>	
<b>Motor holding brake connection</b>		
Max. output current	3 A	
Max. number of switching cycles	Approx. 80000	
<b>Braking resistors</b>		
Peak power int. / ext.	7 / 250 kW	
Continuous power int. / ext.	0.2 / 24 kW <sup>9)</sup>	
Minimum braking resistance (ext.)	2.5 Ω	
Rated current of the built-in fuse	30 A (fast-acting)	
<b>Limit switch and reference inputs</b>		
Quantity	3	
Wiring	Sink	
Electrical isolation		
Input - ACOPOS	Yes	
Input - Input	No	

Table 55: 8V1640.00-2, 8V1640.001-2 - Technical data

Product ID	8V1640.00-2	8V1640.001-2
Input voltage		
Nominal		24 VDC
Maximum		30 VDC
Switching threshold		
Low		<5 V
High		>15 V
Input current at nominal voltage		Approx. 4 mA
Switching delay		Max. 2.0 ms
Modulation compared to ground potential		Max. ±38 V
<b>Enable inputs</b>		
Quantity		1
Wiring		Sink
Electrical isolation		
Input - ACOPOS		Yes
Input voltage		
Nominal		24 VDC
Maximum		30 VDC
Input current at nominal voltage		Approx. 30 mA
Switching threshold		
Low		<5 V
High		>15 V
Switching delay		
Enable 0 -> 1, ready for PWM		Max. 100 µs
Enable 1 -> 0, PWM off		Max. 2.0 ms
Modulation compared to ground potential		Max. ±38 V
<b>Trigger inputs</b>		
Quantity		2
Wiring		Sink
Electrical isolation		
Input - ACOPOS		Yes
Input - Input		No
Input voltage		
Nominal		24 VDC
Maximum		30 VDC
Switching threshold		
Low		<5 V
High		>15 V
Input current at nominal voltage		Approx. 10 mA
Switching delay		
Positive edge		52 µs ±0.5 µs (digitally filtered)
Negative edge		53 µs ±0.5 µs (digitally filtered)
Modulation compared to ground potential		Max. ±38 V
<b>Operating conditions</b>		
Permitted mounting orientations		
Hanging vertically		Yes
Lying horizontally		Yes
Standing horizontally		No
Installation at altitudes above sea level		
Nominal		0 to 500 m
Maximum <sup>10)</sup>		2000 m
Degree of pollution in accordance with EN 60664-1		2 (non-conductive pollution)
Overvoltage category in accordance with IEC 60364-4-443:1999		II
EN 60529 protection		IP20
<b>Environmental conditions</b>		
Temperature		
Operation		
Nominal		5 to 40°C
Maximum <sup>11)</sup>		55°C
Storage		-25 to 55°C
Transport		-25 to 70°C
Relative humidity		
Operation		5 to 85%
Storage		5 to 95%
Transport		Max. 95% at 40°C
<b>Mechanical characteristics</b>		
Dimensions		
Width		276 mm
Height		460 mm
Depth		295 mm
Weight		24.1 kg

Table 55: 8V1640.00-2, 8V1640.001-2 - Technical data

- 1) In the USA, TT and TN power mains are commonly referred to as "Delta/Wye with grounded Wye neutral".
- 2) Limit values from CISPR11, group 2, class A (second environment).
- 3) The current requirements depend on the configuration of the ACOPOS servo drive.

- 4) If the mains input voltage (3x 400 VAC to 480 VAC  $\pm 10\%$ ) is applied, then the 24 VDC supply voltage for the ACOPOS servo drive is generated by the internal DC bus power supply, reducing the 24 VDC current consumption ( $I_{24\text{VDC}}$ ) to 0.
- 5) If the mains input voltage (3x 400 VAC to 480 VAC  $\pm 10\%$ ) is not applied, the voltage is generated at the 24 VDC output from the ACOPOS servo drive's 24 VDC supply voltage; in this case, it is between the maximum permissible and minimum permissible (reduced by max. 2.5 V) 24 VDC supply voltage of the ACOPOS servo drive.
- 6) Valid in the following conditions: 400 VAC mains input voltage, nominal switching frequency, 40°C ambient temperature, installation altitude <500 m above sea level.
- 7) Value for the nominal switching frequency.
- 8) The module's electrical output frequency (SCTRL\_SPEED\_ACT \* MOTOR\_POLEPAIRS) is monitored to protect against dual use in accordance with EC 428/2009 | 3A225. If the electrical output frequency of the module exceeds the limit value of 600 Hz uninterrupted for more than 0.5 s, then the current movement is aborted and error 6060 is output (power unit: limit speed exceeded).
- 9) Continuous power refers to the maximum braking power the ACOPOS servo drive can exchange continuously. Depending on the application, the actual continuous power provided by the external braking resistor is limited by the rated current of fuse  $I_b$  (integrated in the ACOPOS servo drive), and the value of the external braking resistance  $R_{BR}$ .
- 10) Continuous operation of ACOPOS servo drives at altitudes ranging from 500 m to 2000 m above sea level is possible (taking the specified continuous current reductions into consideration). Requirements that go above and beyond this need to be arranged with B&R.
- 11) Continuous operation of ACOPOS servo drives at ambient temperatures ranging from 40°C to max. 55°C is possible (taking the specified continuous current reductions into consideration), but this will result in a shorter service life.

## 2.6.2 ACOPOS 128M

### 2.6.2.1 Order data


Model number	Short description	Figure
8V128M.00-2	ACOPOS servo drive, 3x 400-480 V, 128 A, 64 kW, line filter, integrated braking resistor, DC bus power supply and electronic secure restart inhibit	
8V128M.001-2	ACOPOS servo drive, 3x 400-480 V, 128 A, 64 kW, coated, line filter, integrated braking resistor, DC bus power supply and electronic secure restart inhibit	
<b>Optional accessories</b>		
<b>Braking resistors</b>		
8B0W0045H000.000-1	ACOPOS multi braking resistor, 450 W, 50 R, IP20, terminals	
8B0W0045H000.001-1	ACOPOS multi braking resistor, 450 W, 50 R, IP65, terminals	
8B0W0079H000.000-1	ACOPOS multi braking resistor, 790 W, 33 R, IP20, terminals	
8B0W0079H000.001-1	ACOPOS multi braking resistor, 790 W, 33 R, IP65, terminals	
<b>Plug-in modules</b>		
8AC110.60-2	ACOPOS plug-in module, CAN interface	
8AC114.60-2	ACOPOS plug-in module, POWERLINK V2 interface	
8AC120.60-1	ACOPOS plug-in module, EnDat encoder and sine incremental encoder interface	
8AC121.60-1	ACOPOS plug-in module, HIPERFACE interface	
8AC122.60-3	ACOPOS plug-in module, resolver interface 10 kHz	
8AC123.60-1	ACOPOS plug-in module, incremental encoder and SSI absolute encoder interface	
8AC125.60-1	ACOPOS plug-in module, BiSS encoder interface 5 V	
8AC125.60-2	ACOPOS plug-in module, BiSS encoder interface 5V, baud rate 6.25 Mbit/s	
8AC125.61-2	ACOPOS plug-in module, BiSS encoder interface 12V, baud rate 6.25 Mbit/s	
8AC126.60-1	ACOPOS plug-in module, EnDat 2.2 encoder interface	
8AC130.60-1	ACOPOS plug-in module, 8 digital I/O configurable in pairs as 24 V input or as output 400/100 mA, 2 digital outputs 2 A, order TB712 terminal block separately.	
8AC131.60-1	ACOPOS plug-in module, 2 analog inputs $\pm 10$ V, 2 digital I/O points which can be configured as a 24 V input or 45 mA output, order TB712 terminal block separately.	
8AC132.60-1	ACOPOS plug-in module, 2 analog inputs $\pm 10$ V	
8AC140.60-3	ACOPOS plug-in module, CPU, x86 100 MHz Intel compatible, 32 MB DRAM, 32 kB SRAM, removable application memory: CompactFlash, 1 CAN interface, 1 Ethernet interface 100 Base-T, 1 PROFIBUS DP slave interface, 1 RS232 interface, 3 digital I/O can be configured as 24 VDC input or 500 mA output, 1 analog input $\pm 10$ V, order program memory and 0TB708 terminal block separately.	
8AC140.61-3	ACOPOS plug-in module, CPU, ARNC0, x86 100 MHz Intel compatible, 32 MB DRAM, 32 kB SRAM, removable application memory: CompactFlash, 1 CAN interface, 1 Ethernet interface 100 Base-T, 1 PROFIBUS DP slave interface, 1 RS232 interface, 3 digital I/O can be configured as 24 VDC input or 500 mA output, 1 analog input $\pm 10$ V, order program memory and 0TB708 terminal block separately.	
8AC141.60-2	ACOPOS plug-in module, CPU, x86 100 MHz Intel compatible, 16 MB DRAM, 32 kB SRAM, removable application memory: CompactFlash, 2 CAN interfaces, 1 Ethernet interface 100 Base-T, 1 RS232 interface, 1 X2X Link Master interface, 3 digital I/O can be configured as 24 VDC input or output 500 mA, 1 analog input $\pm 10$ V, order program memory and 0TB704 and 0TB708 terminal blocks separately	
8AC141.61-3	ACOPOS plug-in module, CPU, ARNC0, x86 100 MHz Intel compatible, 32 MB DRAM, 32 kB SRAM, removable application memory: CompactFlash, 2 CAN interfaces, 1 Ethernet interface 100 Base-T, 1 RS232 interface, 1 X2X Link Master interface, 3 digital I/O can be configured as 24 VDC input or output 500 mA, 1 analog input $\pm 10$ V, order program memory and 0TB704 and 0TB708 terminal blocks separately	
<b>Shielding component sets</b>		
8X0030.00-1	ACOPOS shielding components set for 8V1640.xxx-x and 8V128M.xxx-x	
<b>Terminal sets</b>		
8X0005.00-1	ACOPOS accessories, plug set for 8V1640.00 and 8V128M.00 (3 phase)	

Table 56: 8V128M.00-2, 8V128M.001-2 - Order data

## 2.6.2.2 Technical data

Product ID	8V128M.00-2	8V128M.001-2
<b>General information</b>		
B&R ID code	0x12F3	0xA09D
Slots for plug-in modules	4	
Certification c-UL-us	Yes	
<b>Power mains connection</b>		
Permissible power mains forms	TT, TN <sup>1)</sup>	
Mains input voltage	3x 400 VAC to 480 VAC ±10%	
Frequency	50 / 60 Hz ±4%	
Installed load	Max. 98 kVA	
Starting current at 400 VAC	26 A	
Switch-on interval	>10 s	
Integrated line filter in accordance with EN 61800-3, Category C3 <sup>2)</sup>	Yes	
Power loss at max. device power without braking resistor	Approx. 3200 W	
<b>DC bus connection</b>		
DC bus capacitance	6600 µF	
<b>24 VDC supply</b>		
Input voltage	24 VDC +25% / -20%	
Input capacitance	32800 µF	
Current requirements at 24 VDC <sup>3)</sup>		
Mains input voltage applied	- <sup>4)</sup>	
Mains input voltage not applied	Max. 5.7 A + 1.4 * (current for the motor holding brake + current on the 24 VDC output)	
DC bus power supply Switch-on voltage	455 VDC	
<b>24 VDC output</b>		
Output voltage		
Mains input voltage applied	22 to 24 VDC	
Mains input voltage not applied	16.7 to 30 VDC <sup>5)</sup>	
Output current	Max. 0.5 A	
<b>Motor connection</b>		
Quantity	1	
Continuous current <sup>6)</sup>	128 A <sub>eff</sub>	
Reduction of continuous current depending on the ambient temperature		
Mains input voltage: 400 VAC		
Switching frequency 5 kHz	No reduction <sup>7)</sup>	
Switching frequency 10 kHz	1.65 A <sub>eff</sub> per °C (starting at 52°C)	
Switching frequency 20 kHz	1.65 A <sub>eff</sub> per °C (starting at 12°C)	
Mains input voltage: 480 VAC		
Switching frequency 5 kHz	No reduction <sup>7)</sup>	
Switching frequency 10 kHz	1.65 A <sub>eff</sub> per °C (starting at 36°C)	
Switching frequency 20 kHz	1.65 A <sub>eff</sub> per °C (starting at 10°C) <sup>8)</sup>	
Reduction of continuous current depending on the altitude		
Starting at 500 m above sea level	12.8 A <sub>eff</sub> per 1000 m	
Peak current	300 A <sub>eff</sub>	
Nominal switching frequency	5 kHz	
Possible switching frequencies	5 / 10 / 20 kHz	
Electrical stress of the connected motor in accordance with IEC TS 60034-25	Limit value curve A	
Max. motor line length	25 m	
Protective measures		
Overload protection	Yes	
Short circuit and ground fault protection	Yes	
Max. output frequency	600 Hz <sup>9)</sup>	
<b>Motor holding brake connection</b>		
Max. output current	3 A	
Max. number of switching cycles	Approx. 80000	
<b>Braking resistors</b>		
Peak power int. / ext.	8.5 / 250 kW	
Continuous power int. / ext.	0.24 / 24 kW <sup>10)</sup>	
Minimum braking resistance (ext.)	2.5 Ω	
Rated current of the built-in fuse	30 A (fast-acting)	
<b>Limit switch and reference inputs</b>		
Quantity	3	
Wiring	Sink	
Electrical isolation		
Input - ACOPOS	Yes	
Input - Input	No	

Table 57: 8V128M.00-2, 8V128M.001-2 - Technical data

Product ID	8V128M.00-2	8V128M.001-2
Input voltage		
Nominal		24 VDC
Maximum		30 VDC
Switching threshold		
Low		<5 V
High		>15 V
Input current at nominal voltage		Approx. 4 mA
Switching delay		Max. 2.0 ms
Modulation compared to ground potential		Max. ±38 V
<b>Enable inputs</b>		
Quantity		1
Wiring		Sink
Electrical isolation		
Input - ACOPOS		Yes
Input voltage		
Nominal		24 VDC
Maximum		30 VDC
Input current at nominal voltage		Approx. 30 mA
Switching threshold		
Low		<5 V
High		>15 V
Switching delay		
Enable 0 -> 1, ready for PWM		Max. 100 µs
Enable 1 -> 0, PWM off		Max. 2.0 ms
Modulation compared to ground potential		Max. ±38 V
<b>Trigger inputs</b>		
Quantity		2
Wiring		Sink
Electrical isolation		
Input - ACOPOS		Yes
Input - Input		No
Input voltage		
Nominal		24 VDC
Maximum		30 VDC
Switching threshold		
Low		<5 V
High		>15 V
Input current at nominal voltage		Approx. 10 mA
Switching delay		
Positive edge		52 µs ±0.5 µs (digitally filtered)
Negative edge		53 µs ±0.5 µs (digitally filtered)
Modulation compared to ground potential		Max. ±38 V
<b>Operating conditions</b>		
Permitted mounting orientations		
Hanging vertically		Yes
Lying horizontally		Yes
Standing horizontally		No
Installation at altitudes above sea level		
Nominal		0 to 500 m
Maximum <sup>1)</sup>		2000 m
Degree of pollution in accordance with EN 60664-1		2 (non-conductive pollution)
Overvoltage category in accordance with IEC 60364-4-443:1999		II
EN 60529 protection		IP20
<b>Environmental conditions</b>		
Temperature		
Operation		
Nominal		5 to 40°C
Maximum <sup>2)</sup>		55°C
Storage		-25 to 55°C
Transport		-25 to 70°C
Relative humidity		
Operation		5 to 85%
Storage		5 to 95%
Transport		Max. 95% at 40°C
<b>Mechanical characteristics</b>		
Dimensions		
Width		402 mm
Height		460 mm
Depth		295 mm
Weight		33.8 kg

Table 57: 8V128M.00-2, 8V128M.001-2 - Technical data

- 1) In the USA, TT and TN power mains are commonly referred to as "Delta/Wye with grounded Wye neutral".
- 2) Limit values from EN 61800-3 C3 (second environment).
- 3) The current requirements depend on the configuration of the ACOPOS servo drive.

- 4) If the mains input voltage (3x 400 VAC to 480 VAC  $\pm 10\%$ ) is applied, then the 24 VDC supply voltage for the ACOPOS servo drive is generated by the internal DC bus power supply, reducing the 24 VDC current consumption ( $I_{24\text{VDC}}$ ) to 0.
- 5) If the mains input voltage (3x 400 VAC to 480 VAC  $\pm 10\%$ ) is not applied, the voltage is generated at the 24 VDC output from the ACOPOS servo drive's 24 VDC supply voltage; in this case, it is between the maximum permissible and minimum permissible (reduced by max. 2.5 V) 24 VDC supply voltage of the ACOPOS servo drive.
- 6) Valid in the following conditions: 400 VAC mains input voltage, nominal switching frequency, 40°C ambient temperature, installation altitude <500 m above sea level.
- 7) Value for the nominal switching frequency.
- 8) For a mains input voltage of 480 VAC and a switching frequency of 20 kHz, a maximum continuous current of 95 A<sub>eff</sub> is permitted. At ambient temperatures >10°C, a reduction of the continuous current of 1.65 A<sub>eff</sub> per °C must be taken into consideration.
- 9) The module's electrical output frequency (SCTRL\_SPEED\_ACT \* MOTOR\_POLEPAIRS) is monitored to protect against dual use in accordance with EC 428/2009 | 3A225. If the electrical output frequency of the module exceeds the limit value of 600 Hz uninterrupted for more than 0.5 s, then the current movement is aborted and error 6060 is output (power unit: limit speed exceeded).
- 10) Continuous power refers to the maximum braking power the ACOPOS servo drive can exchange continuously. Depending on the application, the actual continuous power provided by the external braking resistor is limited by the rated current of fuse I<sub>B</sub> (integrated in the ACOPOS servo drive), and the value of the external braking resistance R<sub>BR</sub>.
- 11) Continuous operation of ACOPOS servo drives at altitudes ranging from 500 m to 2000 m above sea level is possible (taking the specified continuous current reductions into consideration). Requirements that go above and beyond this need to be arranged with B&R.
- 12) Continuous operation of ACOPOS servo drives at ambient temperatures ranging from 40°C to max. 55°C is possible (taking the specified continuous current reductions into consideration), but this will result in a shorter service life.

### 2.6.3 Wiring

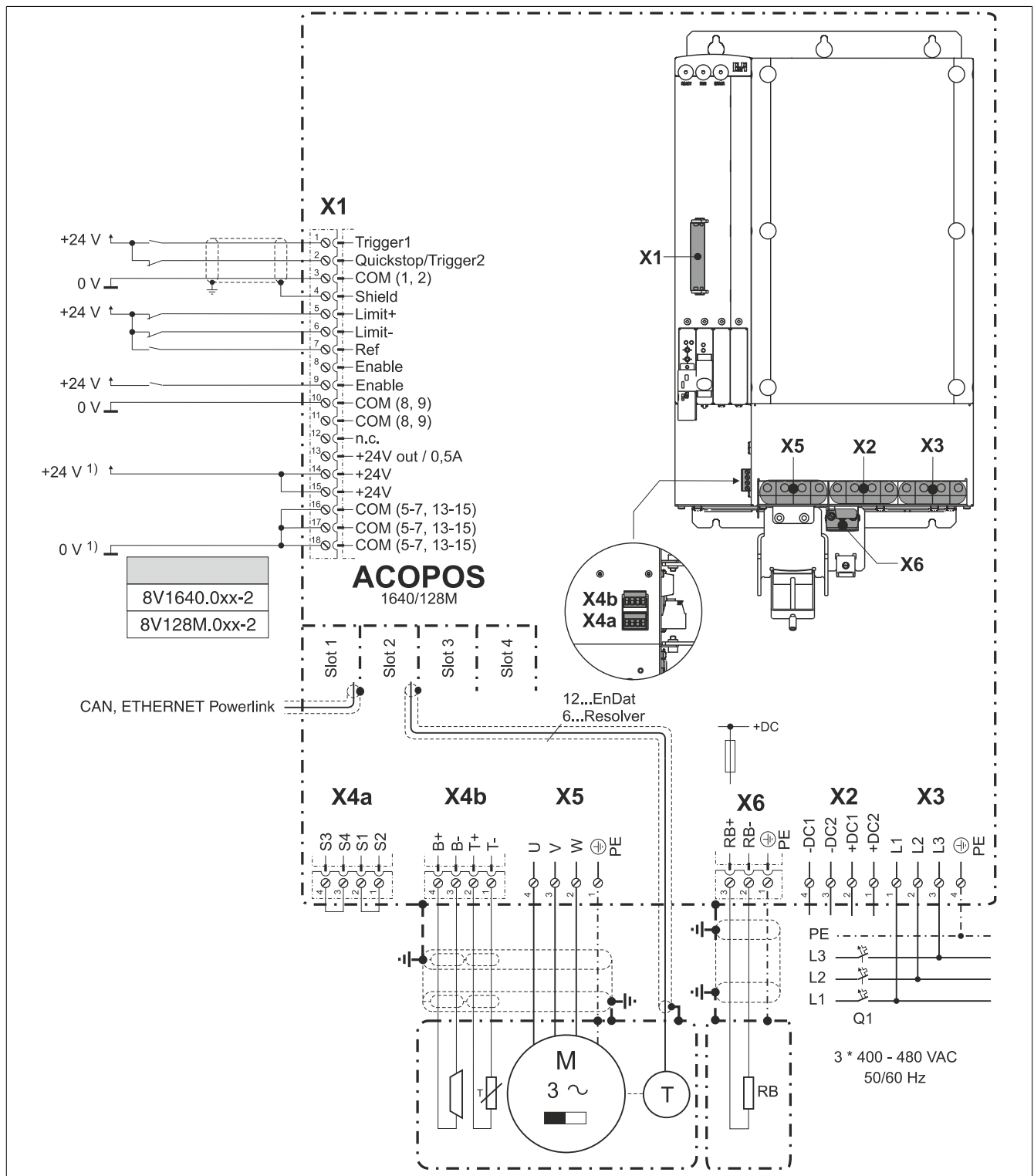


Figure 28: ACOPOS 1640, 128M - Pinout overview

- 1) When using an external 24 VDC supply for the ACOPOS 1640 and 128M servo drives, both +24 VDC connections (X1/14, X1/15) and at least two of the three COM connections (X1/16, X1/17, X1/18) always have to be wired so that the individual terminals are not overloaded.

### 2.6.3.1 X1 connector - Pinout

Pin	Name	Function
1	Trigger1	Trigger 1
2	Quickstop/Trigger2	Quickstop/Trigger2
3	COM (1, 2)	Trigger 1, Quickstop/Trigger 2 0 V
4	Shield	Shield
5	Limit+	Positive HW limit
6	Limit-	Negative HW limit
7	Ref	Reference switch
8	Enable <sup>1)</sup>	Enable
9	Enable <sup>1)</sup>	Enable
10	COM (8, 9)	Enable 0 V
11	COM (8, 9)	Enable 0 V
12	---	---
13	+24V out / 0.5A	+24 V output / 0.5 A
14	+24 V	+24 V supply <sup>2)</sup>
15	+24 V	+24 V supply <sup>2)</sup>
16	COM (5-7, 13-15)	0 V supply <sup>2)</sup>
17	COM (5-7, 13-15)	0 V supply <sup>2)</sup>
18	COM (5-7, 13-15)	0 V supply <sup>2)</sup>

The following connections are linked with each other internally in the device:

- Pin 8 --> Pin 9 (Enable)
- Pin 10 --> Pin 11 (Enable 0 V)
- Pin 14 --> Pin 15 (Supply +24 V)
- Pin 16 --> Pin 17 --> Pin 18 (Supply 0 V)

Terminal cross sections see "Overview of clampable cross sections" on page 245

Table 58: X1 connector - Pinout

- 1) The wiring is not permitted to exceed a total length of 30 m.
- 2) When using an external 24 VDC supply for the ACOPOS 1640 and 128M servo drives, both +24 VDC connections (X1/14, X1/15) and at least two of the three COM connections (X1/16, X1/17, X1/18) always have to be wired so that the individual terminals are not overloaded.

### 2.6.3.2 X2 connector - Pinout

Pin	Name	Function
1	+DC2	U DC bus +
2	+DC1	U DC bus +
3	-DC2	U DC bus -
4	-DC2	U DC bus -

Terminal cross sections see "Overview of clampable cross sections" on page 245

Table 59: X2 connector - Pinout

### 2.6.3.3 X3 connector - Pinout

## Danger!

Servo drives are not permitted to be operated directly on IT and TN-S mains with a grounded phase conductor and protective ground conductor!

Pin	Name	Function
1	L1	Power mains connection L1
2	L2	Power mains connection L2
3	L3	Power mains connection L3
4	⊕	Protective ground conductor

Terminal cross sections see "Overview of clampable cross sections" on page 245

Table 60: X3 connector - Pinout

## 2.6.3.4 X4a, X4b connectors - Pinout

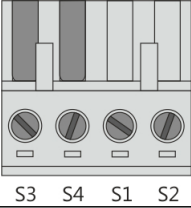
X4a	Pin	Name	Function
	1	S2 <sup>1)</sup>	Activation, supply for the external holding brake (+)
	2	S1 <sup>1)</sup>	Activation for the external holding brake (+)
	3	P4	Activation, supply for the external holding brake (-)
	4	S3	Activation for the external holding brake (-)
	Terminal cross sections see "Overview of clampable cross sections" on page 245		

Table 61: X4a connector - Pinout

- 1) If the holding brake is connected via an additional external relay contact (ground-in e.g. via the connections S1/S2) instead of via the internal transistor, then the internal quenching circuit has no effect! In this case, the customer must make sure that neither the relay contact nor the braking coil are damaged when switching off the brake. This can be done by interconnecting the coil or - better still - interconnecting the contact with a quenching circuit.

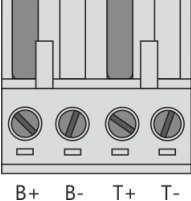
X4b	Pin	Name	Function
	1	T-	Temperature sensor -
	2	T+	Temperature sensor +
	3	B- <sup>1)</sup>	Brake -
	4	B+ <sup>1)</sup>	Brake +

Table 62: X4b connector - Pinout

- 1) If the holding brake is connected via an additional external relay contact (ground-in e.g. via the connections S1/S2) instead of via the internal transistor, then the internal quenching circuit has no effect! In this case, the customer must make sure that neither the relay contact nor the braking coil are damaged when switching off the brake. This can be done by interconnecting the coil or - better still - interconnecting the contact with a quenching circuit.

## Danger!

The connections for the motor temperature sensors and the motor holding brake are isolated circuits. Therefore, these connections are only allowed to be connected to devices or components with at least safe isolation in accordance with IEC 60364-4-41 or EN 61800-5-1.

## Caution!

If B+ and B- are swapped when connecting the permanent magnet holding brakes, then the brakes cannot be opened! ACOPOS servo drives cannot determine if a holding brake is connected with reverse polarity!

### 2.6.3.4.1 Wiring the connections for the motor holding brake

The supply, activation and monitoring of the output for the motor holding brake can take place via the X4a connector in three different ways:

	Figure	Description
1		<ul style="list-style-type: none"> <li><b>Supply:</b> Internally by the ACOPOS servo drive</li> <li><b>Activation:</b> Internally by the ACOPOS servo drive</li> <li><b>Monitoring:</b> Internally by the ACOPOS servo drive</li> </ul> <p>A jumper must be placed between S1 and S2 as well as S3 and S4 on the X4a connector. <sup>1)</sup></p>
2		<ul style="list-style-type: none"> <li><b>Supply:</b> Internally by the ACOPOS servo drive</li> <li><b>Activation:</b> Internally by the ACOPOS servo drive and also possible externally using potential-free contacts <sup>2)</sup></li> <li><b>Monitoring:</b> Internally by the ACOPOS servo drive</li> </ul> <p><b>Information:</b> The parameters for internal monitoring via the ACOPOS must be set according to the requirements of the application. <sup>3)</sup></p>
3		<ul style="list-style-type: none"> <li><b>Supply:</b> External</li> <li><b>Activation:</b> External</li> <li><b>Monitoring:</b> External</li> </ul> <p><b>Information:</b> ACOPOS internal monitoring cannot be used here; therefore, it must be disabled using software. <sup>4)</sup></p>

Table 63: Activation for the external holding brake

- Both jumpers are already on the X4a connector delivered with the ACOPOS servo drives.
- External potential-free contacts can be connected between S1 and S2 as well as between S3 and S4. This makes it possible to activate the holding brake using an external safety circuit independent of the control integrated in the ACOPOS servo drive.
- The parameters are set using ParID 90 (1 ... internal monitoring active; 5 ... internal monitoring not active).
- Deactivation takes place using ParID 90 (5 ... internal monitoring not active).

### 2.6.3.5 X5 connector - Pinout

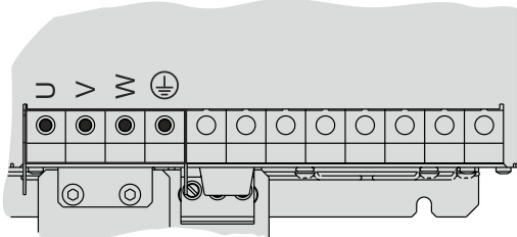
X5	Pin	Name	Function
	1	⊕	Protective ground conductor
	2	W	Motor connection W
	3	V	Motor connection V
	4	U	Motor connection U
Terminal cross sections see "Overview of clampable cross sections" on page 245			

Table 64: X5 connector - Pinout

### 2.6.3.6 X6 connector - Pinout

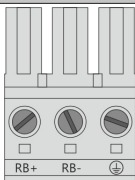
X6	Pin	Name	Function
	1	PE	Protective ground conductor
	2	RB-	Braking resistor -
	3	RB+	Braking resistor +
Terminal cross sections see "Overview of clampable cross sections" on page 245			

Table 65: X6 connector - Pinout

### 2.6.3.7 Input/Output circuit diagram

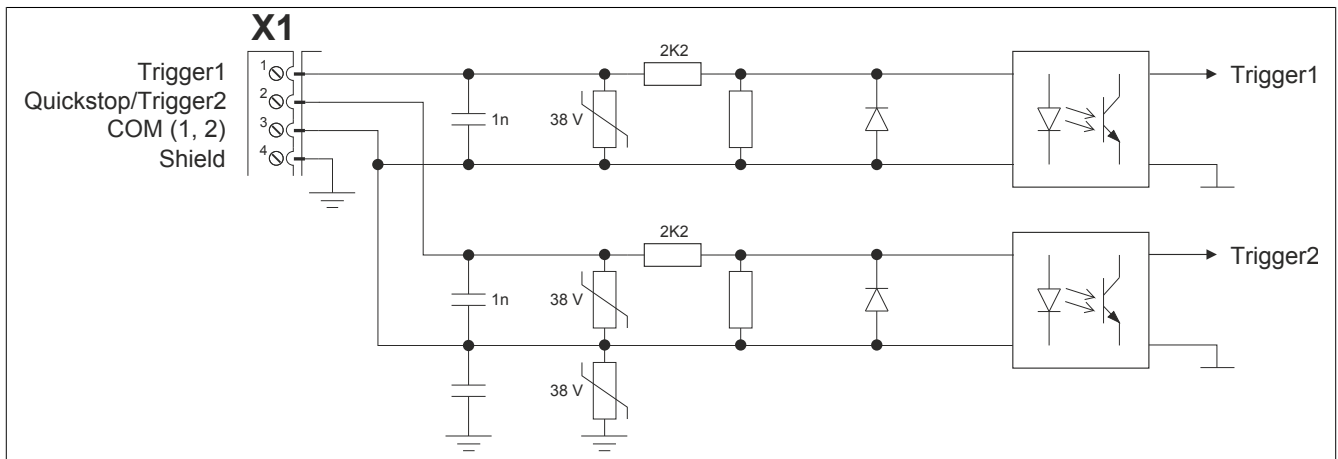


Figure 29: Trigger

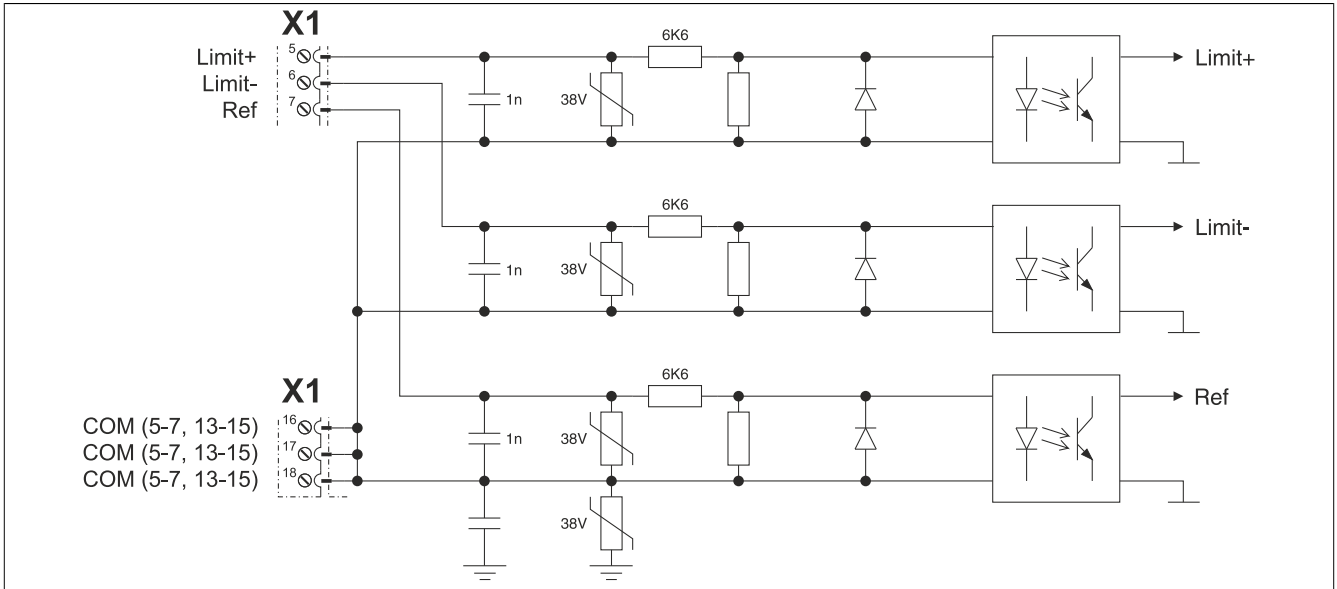


Figure 30: Limit

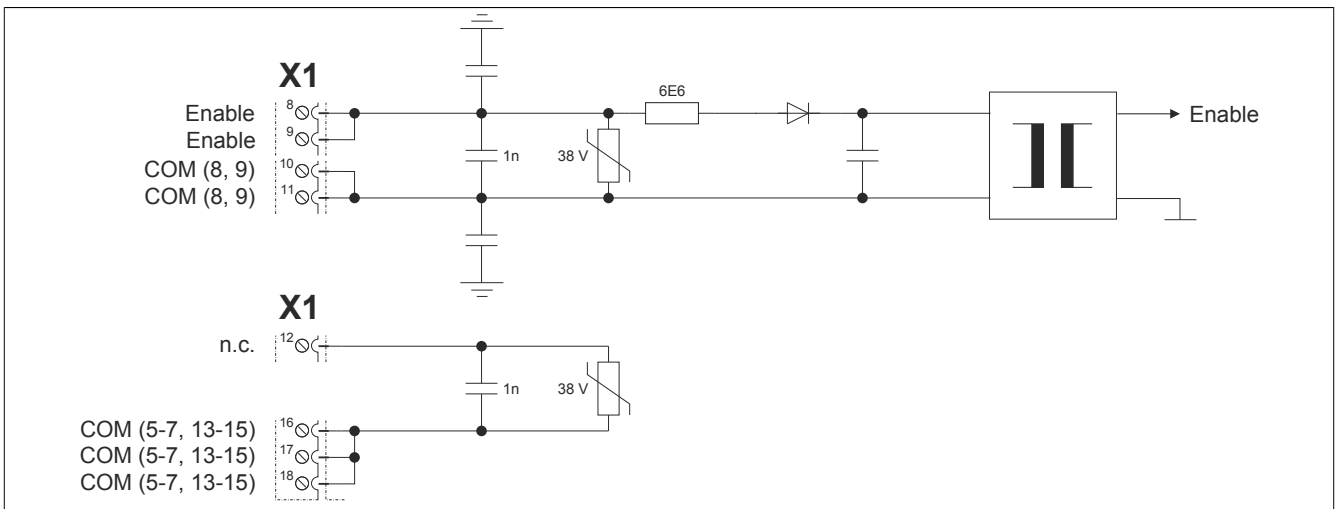


Figure 31: Enable

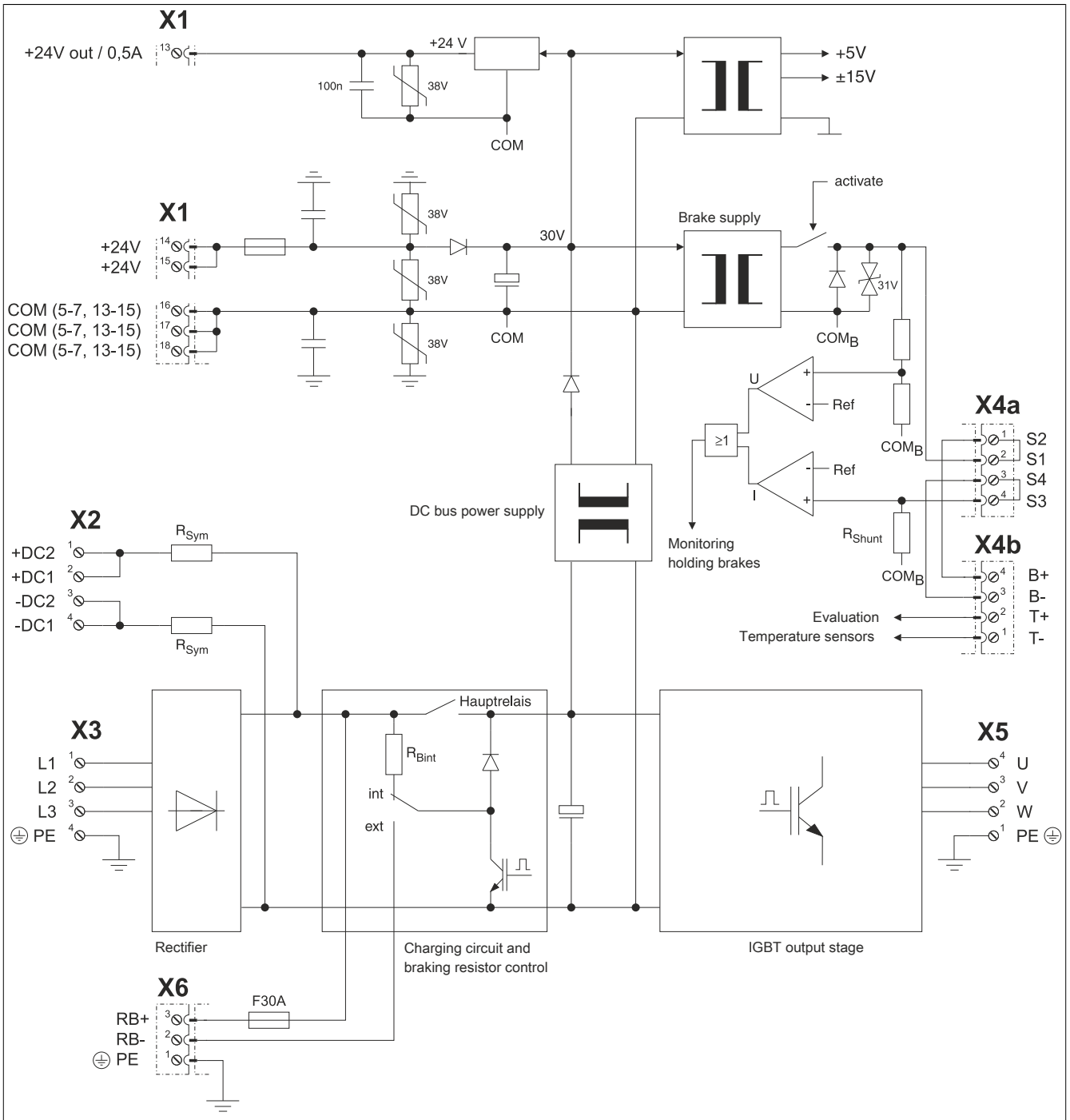


Figure 32: ACOPOS 1640, 128M - Input/Output circuit diagram

## 3 ACOPOS plug-in modules

### 3.1 General information

ACOPOS drives are equipped with up to four plug-in module slots depending on the size.

	8V1010.0xx-2 8V1010.5xx-2 8V1016.0xx-2 8V1016.5xx-2	8V1022.0xx-2 8V1045.0xx-2 8V1090.0xx-2	8V1180.0xx-2 8V1320.0xx-2	8V1640.0xx-2 8V128M.0xx-2
Max. number of plug-in modules	3		4	

Table 66: The maximum number of plug-in modules depends on the size of the servo drive

You can select the plug-in modules required for your application and insert them into the ACOPOS servo drive.

### 3.2 AC110 - CAN Interface

#### 3.2.1 General information

The AC110 plug-in module can be used in an ACOPOS slot. The module is equipped with a CAN interface. This fieldbus interface is used for communication and setting parameters on the ACOPOS servo drive for standard applications.

#### 3.2.2 Order data


Model number	Short description	Figure
	<b>Plug-in modules</b>	
8AC110.60-2	ACOPOS plug-in module, CAN interface	
	<b>Optional accessories</b>	
	<b>Infrastructure components</b>	
0AC912.9	Bus adapter, CAN, 1 CAN interface	
0AC913.92	Bus adapter, CAN, 2 CAN interfaces, including 30 cm attachment cable (DSUB)	
7AC911.9	Bus connector, CAN	

Table 67: 8AC110.60-2 - Order data

#### 3.2.3 Technical data

Product ID	8AC110.60-2
<b>General information</b>	
Module type	ACOPOS plug-in module
B&R ID code	0x1198
Slot	Slot 1
Power consumption	Max. 0.7 W
Certification c-UL-us	Yes
<b>Interfaces</b>	
CAN	
Quantity	1
Module-side connection	9-pin DSUB plug
Status indicators	RXD/TXD LEDs
Baud rate	500 kbit/s
Bus terminating resistor	Externally wired
Electrical isolation	Yes
Max. distance	60 m
Network-capable	Yes
<b>Environmental conditions</b>	
Temperature	
Operation	
Nominal	5 to 40°C
Maximum	55°C
Storage	-25 to 55°C
Transport	-25 to 70°C

Table 68: 8AC110.60-2 - Technical data

<b>Product ID</b>	<b>8AC110.60-2</b>
Relative humidity	
Operation	5 to 85%
Storage	5 to 95%
Transport	Max. 95% at 40°C

Table 68: 8AC110.60-2 - Technical data

### 3.2.4 Setting the CAN station number

The CAN station number can be set using two HEX switches:


Figure	Switch	CAN station number
	1	16s position (high)
	2	1s position (low)
	The station number change takes effect the next time the ACOPOS servo drive is switched on.	
<b>Information:</b> Changing the station number using software is not possible (Basis CAN ID can be changed). The ACOPOS Manager only supports station numbers 1 - 32. When using the NC157 positioning module, only station numbers 1 - 8 are possible.		

Table 69: Setting the CAN station number

There must be a terminating resistor (120 Ω, 0.25 W) between CAN\_H and CAN\_L at the beginning and end of the CAN bus.

### 3.2.5 Status indicators

The status LEDs indicate if data is being received (RXD) or sent (TXD).

### 3.2.6 Firmware

The firmware is part of the operating system for the ACOPOS servo drives. Firmware is updated by updating the ACOPOS operating system.

### 3.2.7 Wiring

#### 3.2.7.1 Pinout

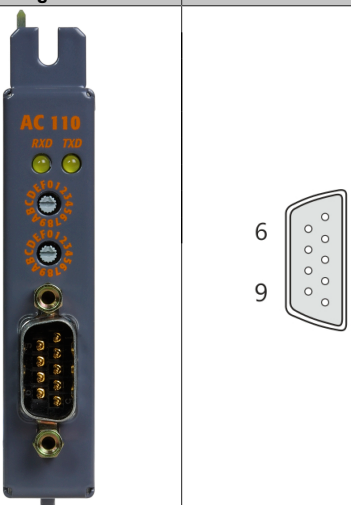
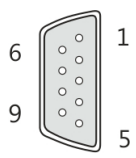
Figure	X11	Pin	Name	Function
		1	---	---
		2	CAN_L	CAN low
		3	COM (2, 7)	CAN 0 V
		4	---	---
		5	---	---
		6	---	---
		7	CAN_H	
		8	---	---
		9	---	---

Table 70: AC110 CAN interface - Pinout

### 3.2.7.2 Input/output diagram

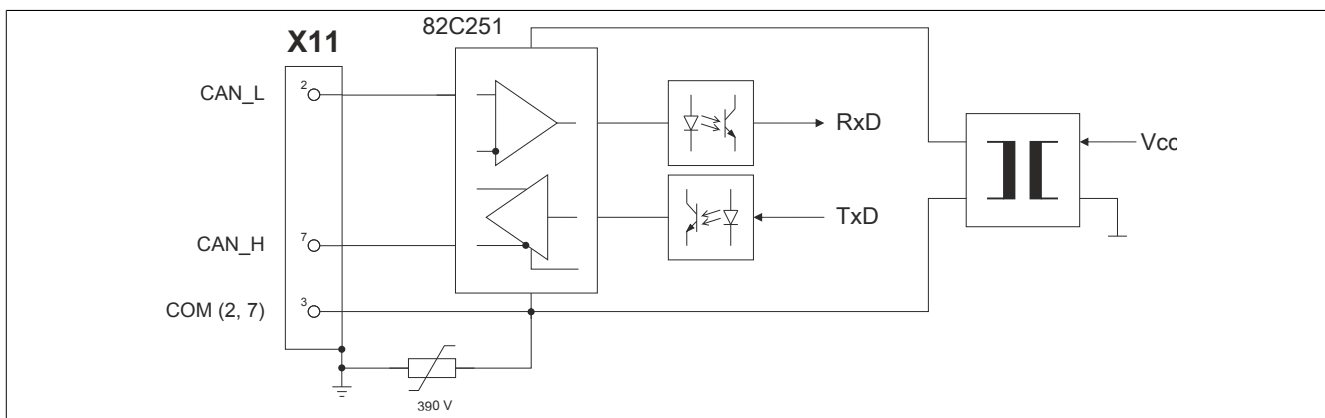


Figure 33: AC110 - Input/Output circuit diagram

### 3.3 AC114 - POWERLINK V2 Interface

#### 3.3.1 General information

The AC114 plug-in module can be used in an ACOPOS slot. The module is equipped with a POWERLINK V2 interface. This fieldbus interface is used for communication and setting parameters on the ACOPOS servo drive for complex and time critical applications.

The plug-in module is a 2x hub. This makes it easy to establish a device-to-device connection (line topology).

#### 3.3.2 Order data


Model number	Short description	Figure
	<b>Plug-in modules</b>	
8AC114.60-2	ACOPOS plug-in module, POWERLINK V2 interface	

Table 71: 8AC114.60-2 - Order data

#### 3.3.3 Technical data

Product ID	8AC114.60-2
<b>General information</b>	
Module type	ACOPOS plug-in module
B&R ID code	0xA5C1
Slot	Slot 1
Power consumption	Max. 3 W
Certification c-UL-us	Yes
<b>Interfaces</b>	
POWERLINK	1
Quantity	2x RJ45 port
Module-side connection	Status LED + 2x Link LED
Status indicators	100 Mbit/s
Transfer rate	Yes
Hub, 2x	Synchronous to POWERLINK cycle
Possible station operating modes	Yes
Electrical isolation	Star or tree with level 2 hubs
Cabling topology	10
Maximum number of hub levels	Max. 100 m between two stations (segment length) <sup>1)</sup>
Cable length	Yes
Network-capable	Yes
Watchdog functionality	Yes (via ACOPOS servo drive)
Hardware	Yes (via ACOPOS servo drive)
Software	
<b>Environmental conditions</b>	
Temperature	
Operation	
Nominal	5 to 40°C
Maximum	55°C
Storage	-25 to 55°C
Transport	-25 to 70°C
Relative humidity	
Operation	5 to 85%
Storage	5 to 95%
Transport	Max. 95% at 40°C

Table 72: 8AC114.60-2 - Technical data

1) With a cycle time of 400 µs and 10 ACOPOS servo drives, the maximum total cable length is 200 m.

### 3.3.4 Setting the POWERLINK station number

The POWERLINK station number can be set using two HEX code switches:


Figure	Switch	POWERLINK station number
	1	16s position (high)
	2	1s position (low)
<p>A changed POWERLINK station number will take effect the next time the ACOPOS servo drive is switched on.</p> <p><b>Information:</b></p> <p>In principle, station numbers between \$01 and \$FD are permitted. However, station numbers between \$F0 and \$FD are intended for future system expansions. To ensure compatibility, these station numbers should be avoided.</p> <p>Station numbers \$00, \$FE and \$FF are reserved and may therefore not be set.</p>		

Table 73: Setting the POWERLINK station number

### 3.3.5 Status indicators


Figure	LED	Labeling	Color	Function	Description
	1	R/E	Green/Red	Ready/Error	See "Table 75: POWERLINK - LED status indicators" on page 106
	2	RX	Green	Link / data activity	

Table 74: AC114 - Status LEDs

Labeling	Color	Function	Description	
R/E	Green/Red	Ready/Error	LED not lit	The module is not receiving power or initialization of the network interface has failed.
			Red (lit)	The POWERLINK station number of the module is 0.
			Red/green, blinking	The client is in an error state (drops out of cyclic operation).
			Green (blinking) (single)	The client detects a valid POWERLINK frame on the network.
			Green (blinking) (2x)	Cyclic operation on the network is taking place, but the client itself is not yet a participant.
			Green (blinking) (3x)	Cyclic operation of the client is in preparation.
			Green (lit)	The client is participating in cyclic operation.
			Green (flickering)	The client is not participating in cyclic operation and also does not detect any other stations on the network participating in cyclic operation.
RX	Green	Link / data activity	Green (not lit)	Hardware not connected
			Green (lit)	Hardware connected
			Green (flickering)	Activity on port

Table 75: POWERLINK - LED status indicators

### 3.3.6 Firmware

The firmware is part of the operating system for the ACOPOS servo drives. Firmware is updated by updating the ACOPOS operating system.

### 3.3.7 Wiring

#### 3.3.7.1 Pinout




Figure	IF2	Pin	Name	Function
		1	RXD	Receive signal
		2	RXD\	Receive signal inverted
		3	TXD	Transmit signal
		4	Shield	Shield
		5	Shield	Shield
		6	TXD\	Transmit signal inverted
		7	Shield	Shield
		8	Shield	Shield
	IF1	Pin	Name	Function
		1	RXD	Receive signal
		2	RXD\	Receive signal inverted
		3	TXD	Transmit signal
		4	Shield	Shield
		5	Shield	Shield
		6	TXD\	Transmit signal inverted
		7	Shield	Shield
8		Shield	Shield	

Table 76: AC114 POWERLINK V2 interface - Pinout

#### Information:

In general, crossover Ethernet cables must be used for POWERLINK connections!

Cables should be plugged in and unplugged carefully. Otherwise, the shield connection could break between the RJ45 connector and the cable shield which could then cause connection disturbances!

#### 3.3.7.2 Input/output diagram

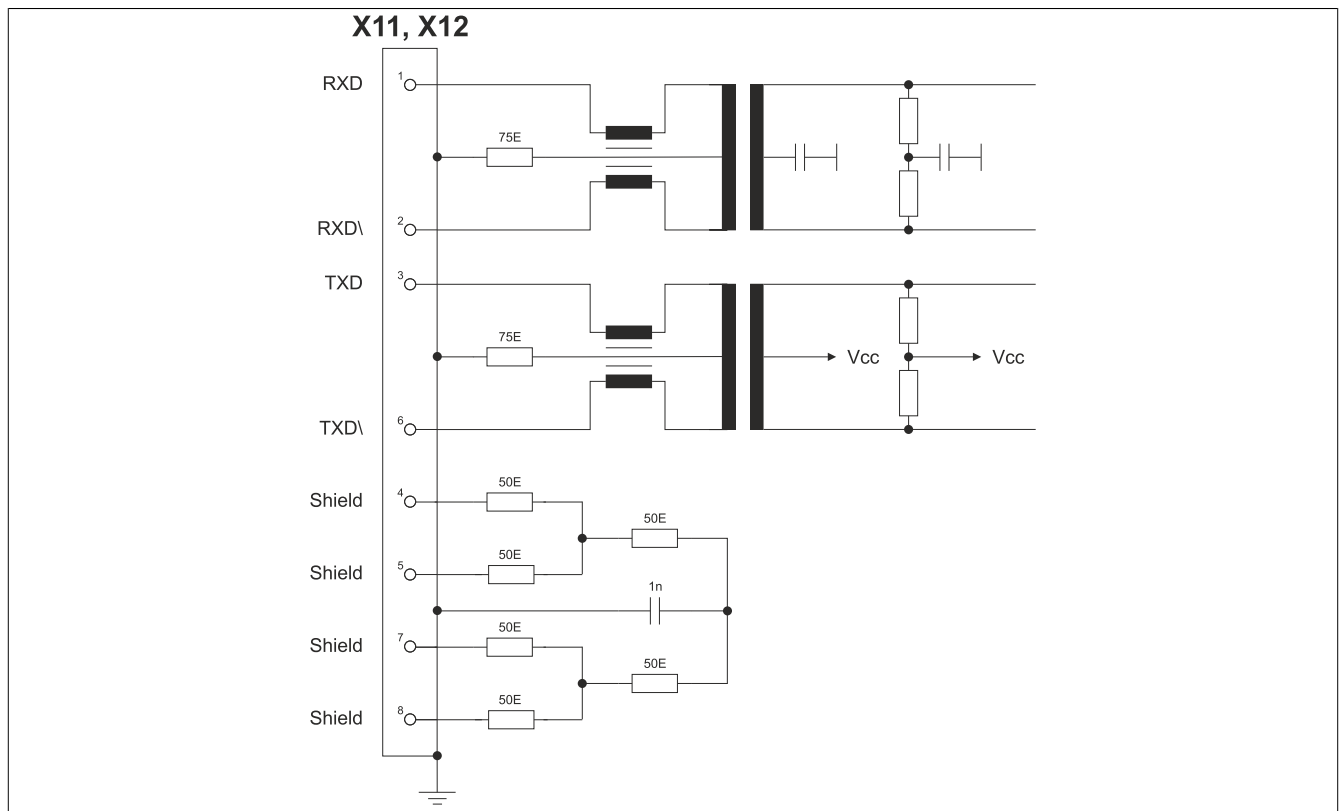


Figure 34: AC114 - Input/Output circuit diagram

### 3.4 AC120 - EnDat encoder interface

#### 3.4.1 General information

The AC120 plug-in module can be used in an ACOPOS slot. The module has an EnDat encoder interface but can also be used to evaluate simple incremental encoders with a sinusoidal output signal. <sup>1)</sup>

This module can be used to evaluate encoders installed in B&R servo motors as well as encoders for external axes (encoders that scan any machine movement). The input signals are monitored. This makes it possible to detect open or shorted lines as well as encoder supply failures.

#### EnDat encoder:

EnDat is a standard developed by Johannes Heidenhain GmbH ([www.heidenhain.de](http://www.heidenhain.de)) that incorporates the advantages of absolute and incremental position measurement while also offering a read/write parameter memory in the encoder. With absolute position measurement (the absolute position is sampled serially), a homing procedure is usually not required. Where necessary, a multi-turn encoder (4096 revolutions) should be installed. To save costs, a single-turn encoder and a reference switch can also be used. In this case, a homing procedure must be carried out.

The incremental process allows the short delay times necessary for position measurement on drives with exceptional dynamic properties. With the sinusoidal incremental signal and the fine resolution in the EnDat module, a very high positioning resolution is achieved in spite of the moderate signal frequencies used.

The parameter memory in the EnDat encoder is used by B&R to store motor data (among other things). In this way, the ACOPOS drive system is always automatically provided the correct motor parameters and limit values. This is referred to as the "embedded parameter chip".

During startup, the plug-in module is automatically identified, configured and its parameters set by the ACOPOS servo drive operating system.

#### Incremental encoder with sine formed output signal:

When using the AC120 plug-in module to evaluate simple incremental encoders with an sinusoidal output signal, only the incremental transfer channel is used. The "embedded parameter chip" is not available in this case because this encoder does not have parameter memory. The absolute position is also not available immediately after switching the device on. In this situation, a homing procedure normally has to be carried out. The module is equipped with a reference pulse input for this purpose.

#### 3.4.2 Order data


Model number	Short description	Figure
	<b>Plug-in modules</b>	
8AC120.60-1	ACOPOS plug-in module, EnDat encoder and sine incremental encoder interface	
	<b>Optional accessories</b>	
	<b>EnDat cables</b>	
8CE005.12-1	EnDat 2.1 cable, length 5 m, 10x 0.14 mm <sup>2</sup> + 2x 0.5 mm <sup>2</sup> , 17-pin Intercontec EnDat connector, 15-pin DSUB servo connector, can be used in cable drag chains, UL/CSA listed	
8CE007.12-1	EnDat 2.1 cable, length 7 m, 10x 0.14 mm <sup>2</sup> + 2x 0.5 mm <sup>2</sup> , 17-pin Intercontec EnDat connector, 15-pin DSUB servo connector, can be used in cable drag chains, UL/CSA listed	
8CE010.12-1	EnDat 2.1 cable, length 10 m, 10x 0.14 mm <sup>2</sup> + 2x 0.5 mm <sup>2</sup> , 17-pin Intercontec EnDat connector, 15-pin DSUB servo connector, can be used in cable drag chains, UL/CSA listed	
8CE015.12-1	EnDat 2.1 cable, length 15 m, 10x 0.14 mm <sup>2</sup> + 2x 0.5 mm <sup>2</sup> , 17-pin Intercontec EnDat connector, 15-pin DSUB servo connector, can be used in cable drag chains, UL/CSA listed	
8CE020.12-1	EnDat 2.1 cable, length 20 m, 10x 0.14 mm <sup>2</sup> + 2x 0.5 mm <sup>2</sup> , 17-pin Intercontec EnDat connector, 15-pin DSUB servo connector, can be used in cable drag chains, UL/CSA listed	
8CE025.12-1	EnDat 2.1 cable, length 25 m, 10x 0.14 mm <sup>2</sup> + 2x 0.5 mm <sup>2</sup> , 17-pin Intercontec EnDat connector, 15-pin DSUB servo connector, can be used in cable drag chains, UL/CSA listed	

Table 77: 8AC120.60-1 - Order data

<sup>1)</sup> Starting with revision F0.

## 3.4.3 Technical data

Product ID	8AC120.60-1
<b>General information</b>	
Module type	ACOPOS plug-in module
B&R ID code	0x0FCC
Slot <sup>1)</sup>	Slots 2, 3 and 4
Power consumption	
Depends on the encoder connected	Yes
E0 ... EnDat single-turn, 512 lines	Max. 2.3 W
E1 ... EnDat multi-turn, 512 lines	Max. 3.1 W
E2 ... EnDat single-turn, 32 lines (inductive)	Max. 3.1 W
E3 ... EnDat multi-turn, 32 lines (inductive)	Max. 3.1 W
E4 ... EnDat single-turn, 512 lines	Max. 2.4 W
E5 ... EnDat multi-turn, 512 lines	Max. 2.7 W
Certification c-UL-us	Yes
<b>Encoder inputs</b>	
Quantity	1
Module-side connection	15-pin DSUB socket
Status indicators	UP/DN LEDs
Electrical isolation	
Encoder - ACOPOS	No
Encoder monitoring	Yes
Encoder supply	
Output voltage	Typ. 5 V
Load capability	250 mA <sup>2)</sup>
Sense lines	2, compensation of max. 2x 0.7 V
Sine/Cosine inputs	
Signal transmission	Differential signals, symmetric
Signal frequency (-3 dB)	DC up to 300 kHz
Signal frequency (-5 dB)	DC up to 400 kHz
Differential voltage	0.5 to 1.25 V <sub>ss</sub>
Common-mode voltage	Max. ±7 V
Terminating resistor	120 Ω
Resolution <sup>3)</sup>	16384 * number of encoder lines
Accuracy <sup>4)</sup>	-
Reference input	
Signal transmission	Differential signal, symmetric
Differential voltage for low	≤ -0.2 V
Differential voltage for high	≥ +0.2 V
Common-mode voltage	Max. ±7 V
Terminating resistor	120 Ω
Serial interface	
Signal transmission	Synchronous
Protocol	RS485
Baud rate	625 kBaud
<b>Environmental conditions</b>	
Temperature	
Operation	
Nominal	5 to 40°C
Maximum	55°C
Storage	-25 to 55°C
Transport	-25 to 70°C
Relative humidity	
Operation	5 to 85%
Storage	5 to 95%
Transport	Max. 95% at 40°C

Table 78: 8AC120.60-1 - Technical data

- 1) The AC120 is an encoder module. Several encoder modules can also be inserted. In this case, the encoder module in the slot with the lowest number is automatically used for motor feedback.
- 2) This value only applies to the encoder. The actual load capacity of the encoder supply is approx. 300 mA. The difference of approx. 50 mA covers the consumption of the terminating resistors that are always present. For longer encoder cables, it is important to note that the maximum voltage drop permitted on the supply wires (there and back) is 1.45 V. This can reduce the permissible load current.
- 3) Depending on the resolution of the connected encoder, in practical applications only a part of this resolution can be used. The usable resolution can be further reduced by signal interferences from the connected encoder.
- 4) In actual operation, precision is limited by the encoder.

### 3.4.4 Status indicators

The UP/DN LEDs are lit depending on the rotational direction and the speed of the connected encoder.

UP LED ... Lit when the encoder position changes in the positive direction.

DN LED ... Lit when the encoder position changes in the negative direction.

The faster the encoder position changes, the brighter the respective LED is lit.

### 3.4.5 Firmware

The firmware is part of the operating system for the ACOPOS servo drives. Firmware is updated by updating the ACOPOS operating system.

### 3.4.6 Wiring

#### 3.4.6.1 Pinout

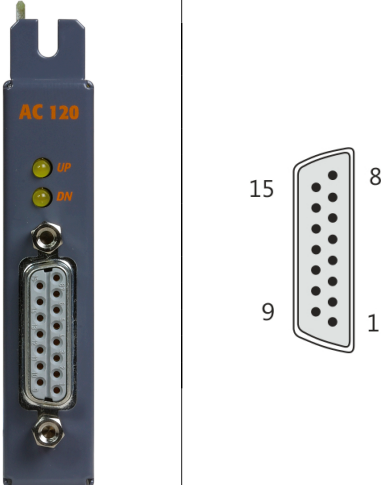
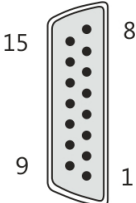
Figure	X11	Pin	Name	Function	
				EnDat mode	Incremental mode
		1	A	Channel A	
		2	COM (1, 3 - 9, 11, 13 - 15)	Encoder supply 0 V	
		3	B	Channel B	
		4	+5V out / 0.25A	Encoder supply +5 V	
		5	D	Data input	---
		6	---	---	
		7	R\	---	Reference pulse inverted
		8	T	Clock output	---
		9	A\	Channel A inverted	
		10	Sense COM	Sense input 0 V	
		11	B\	Channel B inverted	
		12	Sense +5V	Sense input +5 V	
		12	D\	Data inverted	---
		14	R	---	Reference pulse
		15	T\	Clock output inverted	---

Table 79: AC120 EnDat encoder interface - Pinout

## Danger!

The connections for the encoders are isolated circuits. Therefore, these connections are only allowed to be connected to devices or components with at least safe isolation in accordance with IEC 60364-4-41 or EN 61800-5-1.

### 3.4.6.2 Input/Output circuit diagram

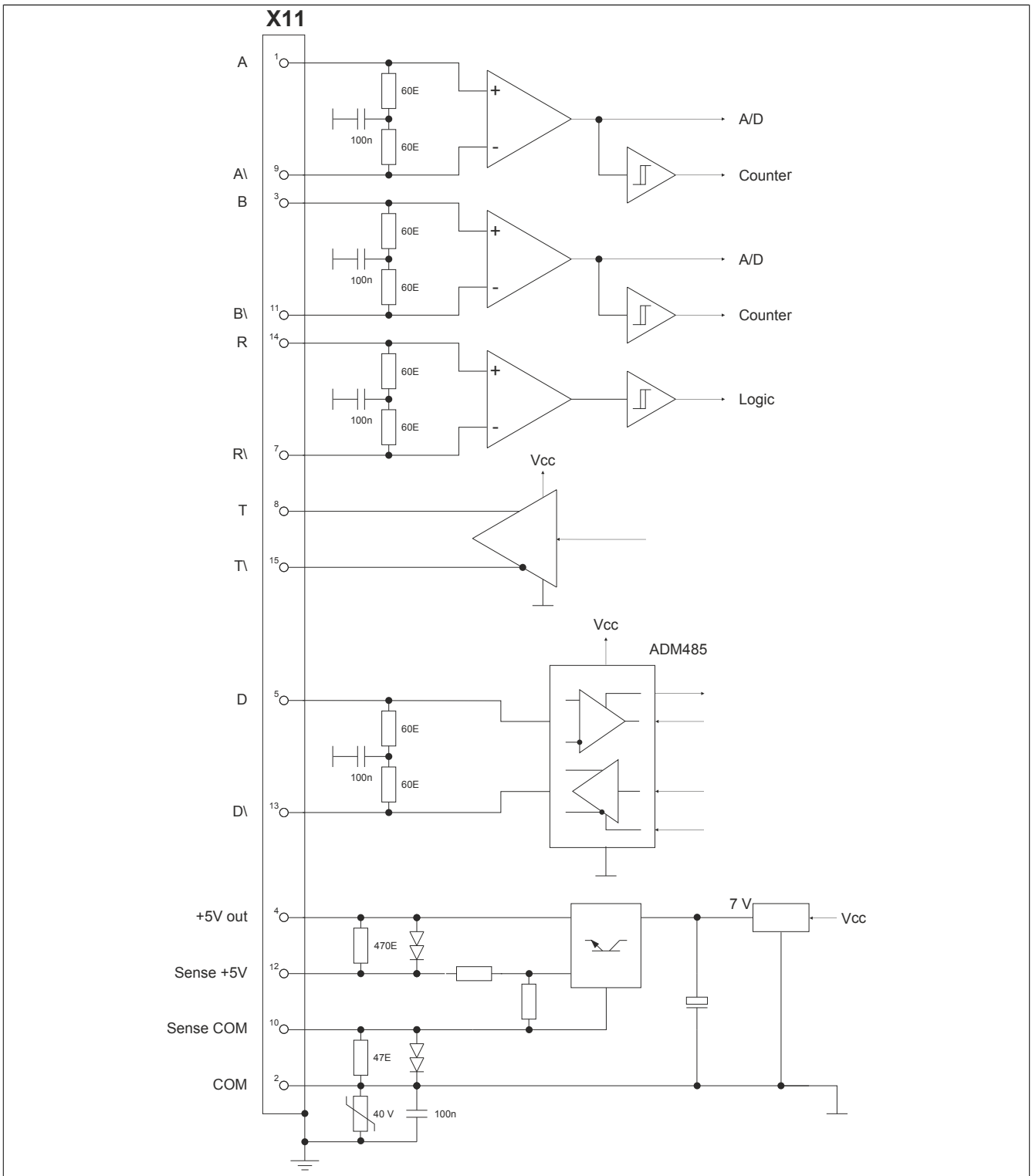


Figure 35: AC120 - Input/Output circuit diagram

### 3.5 AC121 - HIPERFACE encoder interface

#### 3.5.1 General information

The AC121 plug-in module can be used in an ACOPOS slot. It is equipped with a HIPERFACE encoder interface.

This module can be used to evaluate encoders installed in motors from other manufacturers as well as encoders for external axes (encoders that scan any machine movement). The input signals are monitored. This makes it possible to detect open or shorted lines as well as encoder supply failures.

HIPERFACE is a standard developed by Max Stegmann GmbH ([www.stegmann.de](http://www.stegmann.de)), which like EnDat incorporates the advantages of absolute and incremental position measurement while also offering a read/write parameter memory in the encoder. With absolute position measurement (the absolute position is sampled serially), a homing procedure is usually not required. Where necessary, a multi-turn encoder (4096 revolutions) should be installed. To save costs, a single-turn encoder and a reference switch can also be used. In this case, a homing procedure must be carried out.

The incremental process allows the short delay times necessary for position measurement on drives with exceptional dynamic properties. With the sinusoidal incremental signal and the fine resolution in the HIPERFACE module, a very high positioning resolution is achieved in spite of the moderate signal frequencies used.

The parameter memory in the HIPERFACE encoder is available starting with firmware version V1.221.

During startup, the plug-in module is automatically identified, configured and its parameters set by the ACOPOS servo drive operating system.

#### 3.5.2 Order data


Model number	Short description	Figure
	<b>Plug-in modules</b>	
8AC121.60-1	ACOPOS plug-in module, HIPERFACE interface	

Table 80: 8AC121.60-1 - Order data

#### 3.5.3 Technical data

Product ID	8AC121.60-1
<b>General information</b>	
Module type	ACOPOS plug-in module
B&R ID code	0x1558
Slot <sup>1)</sup>	Slots 2, 3 and 4
Power consumption	
With encoder power consumption of 0 mA	0.35 W
With encoder power consumption of 100 mA	1.4 W
With encoder power consumption of 170 mA	2.1 W
Certification	
c-UL-us	Yes
<b>Encoder inputs</b>	
Quantity	1
Module-side connection	15-pin DSUB socket, 2 pins closed
Status indicators	UP/DN LEDs
Electrical isolation	
Encoder - ACOPOS	No
Encoder monitoring	Yes
Encoder supply	
Output voltage	8 to 9 V
Load capability	170 mA
Sense lines	- <sup>2)</sup>

Table 81: 8AC121.60-1 - Technical data

Product ID	8AC121.60-1
Sine/Cosine inputs	
Signal transmission	Differential signal, asymmetric
Signal frequency	DC up to 200 kHz
Differential voltage	0.5 to 1.25 V <sub>ss</sub>
Common-mode voltage	Max. ±7 V
Terminating resistor	120 Ω
Resolution <sup>3)</sup>	16384 * number of encoder lines
Accuracy <sup>4)</sup>	-
Serial interface	
Signal transmission	Asynchronous
Protocol	RS485
Baud rate	9600 baud
<b>Environmental conditions</b>	
Temperature	
Operation	
Nominal	5 to 40°C
Maximum	55°C
Storage	-25 to 55°C
Transport	-25 to 70°C
Relative humidity	
Operation	5 to 85%
Storage	5 to 95%
Transport	Max. 95% at 40°C

Table 81: 8AC121.60-1 - Technical data

- 1) The AC121 is an encoder module. Several encoder modules can also be inserted. In this case, the module in the slot with the lowest number is automatically used for motor feedback.
- 2) No sense lines are present because the supply voltage for the HIPERFACE encoder is permitted to lie between 7 and 12 V.
- 3) Noise on the encoder signal reduces the resolution that can be used by approx. 5 bits (factor of 32).
- 4) In actual operation, precision is limited by the encoder.

### 3.5.4 Status indicators

The UP/DN LEDs are lit depending on the rotational direction and the speed of the connected encoder.

UP LED ... Lit when the encoder position changes in the positive direction.

DN LED ... Lit when the encoder position changes in the negative direction.

The faster the encoder position changes, the brighter the respective LED is lit.

### 3.5.5 Firmware

The firmware is part of the operating system for the ACOPOS servo drives. Firmware is updated by updating the ACOPOS operating system.

### 3.5.6 Wiring

#### 3.5.6.1 Pinout

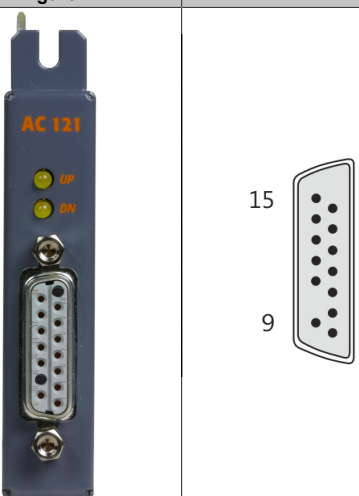
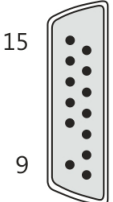
Figure	X11	Pin	Name	Function
		1	SIN	Channel SIN
		2	COM (1, 3 - 5, 9, 11, 13)	Encoder supply 0 V
		3	COS	Channel COS
		4	+8V out / 0.15A	Encoder supply +8 V
		5	D	Data
		6	---	---
		7	---	---
		8	---	--- <sup>1)</sup>
		9	REF SIN	Reference for SIN
		10	---	--- <sup>1)</sup>
		11	REF COS	Reference for COS
		12	---	---
		13	D\	Data inverted
		14	---	---
		15	---	---

Table 82: AC121 HIPERFACE encoder interface - Pinout

- 1) Pins 8 and 10 are closed with plastic plugs. This prevents the accidental connection of a B&R EnDat cable.

## Danger!

The connections for the encoders are isolated circuits. Therefore, these connections are only allowed to be connected to devices or components with at least safe isolation in accordance with IEC 60364-4-41 or EN 61800-5-1.

### 3.5.6.2 Input/Output circuit diagram

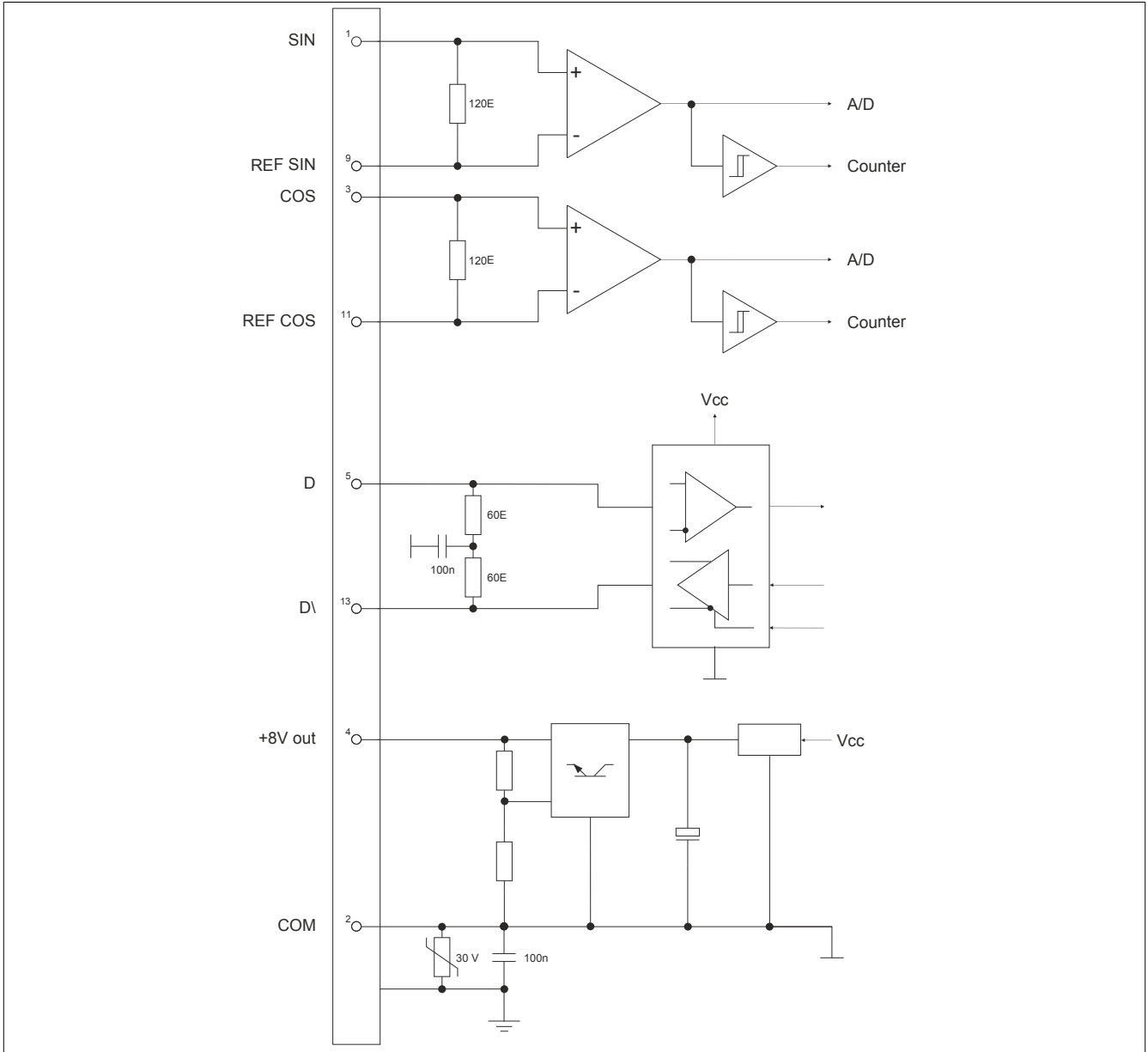


Figure 36: AC121 - Input/Output circuit diagram

## 3.6 AC122 - Resolver interface

### 3.6.1 General information

The AC122 plug-in module can be used in an ACOPOS slot. The module is equipped with a resolver interface.

This plug-in module handles the output from resolvers which are built into B&R servo motors or used as an encoder for external axes. This resolver delivers the absolute position over one revolution. Normally, the movement path is longer than one revolution. In this case, a reference switch must be used and a homing procedure carried out.

The encoder input signals are monitored. This makes it possible to detect open or shorted lines as well as encoder supply (reference signal) failures.

During startup, the plug-in module is automatically identified by the ACOPOS operating system. Making automatic adjustments to the motor (motor parameters, limit values, encoder resolution, etc.) is not possible because the resolver does not have parameter memory like the EnDat encoder.

If the precision, resolution, bandwidth or ease of setting parameters is not sufficient with the resolver, the EnDat system should be used (see "AC120 - EnDat encoder interface " on page 108).

### 3.6.2 Order data


Model number	Short description	Figure
8AC122.60-3	<b>Plug-in modules</b> ACOPOS plug-in module, resolver interface 10 kHz	
	<b>Optional accessories</b>	
	<b>Resolver cables</b>	
8CR005.12-1	Resolver cable, length 5 m, 3x 2x AWG 24 (19x 0.127), 12-pin Intercontec resolver connector, 9-pin DSUB servo connector, can be used in cable drag chains, UL/CSA listed	
8CR007.12-1	Resolver cable, length 7 m, 3x 2x AWG 24 (19x 0.127), 12-pin Intercontec resolver connector, 9-pin DSUB servo connector, can be used in cable drag chains, UL/CSA listed	
8CR010.12-1	Resolver cable, length 10 m, 3x 2x AWG 24 (19x 0.127), 12-pin Intercontec resolver connector, 9-pin DSUB servo connector, can be used in cable drag chains, UL/CSA listed	
8CR015.12-1	Resolver cable, length 15 m, 3x 2x AWG 24 (19x 0.127), 12-pin Intercontec resolver connector, 9-pin DSUB servo connector, can be used in cable drag chains, UL/CSA listed	
8CR020.12-1	Resolver cable, length 20 m, 3x 2x AWG 24 (19x 0.127), 12-pin Intercontec resolver connector, 9-pin DSUB servo connector, can be used in cable drag chains, UL/CSA listed	
8CR025.12-1	Resolver cable, length 25 m, 3x 2x AWG 24 (19x 0.127), 12-pin Intercontec resolver connector, 9-pin DSUB servo connector, can be used in cable drag chains, UL/CSA listed	

Table 83: 8AC122.60-3 - Order data

### 3.6.3 Technical data

Product ID	8AC122.60-3
<b>General information</b>	
Module type	ACOPOS plug-in module
B&R ID code	0xA48B
Slot <sup>1)</sup>	Slots 2, 3 and 4
Power consumption	Max. 2.5 W
Certification c-UL-us	Yes
<b>Resolver inputs</b>	
Reference output	
Output current	Max. 50 mA <sub>eff</sub>
Differential voltage	Typ. 3.4 V <sub>eff</sub>
Frequency	10 kHz
Signal transmission	Differential signals
Angular position resolution	14 bits/rev <sup>2)</sup>
Module-side connection	9-pin DSUB socket
Status indicators	UP/DN LEDs
Bandwidth	2.5 kHz
Encoder monitoring	Yes
Accuracy	±8 angular minutes
Electrical isolation Resolver - ACOPOS	No

Table 84: 8AC122.60-3 - Technical data

Product ID	8AC122.60-3
Resolver	
Input frequency	10 kHz
Input voltage	3 to 7 V <sub>rms</sub>
Number of pins	2-pin
Type	BRX <sup>3)</sup>
Max. phase shift	±45°
Max. elec. angular error	±10 angular minutes
Nominal conversion ratio <sup>4)</sup>	0.5 ±10%
Sine/Cosine inputs	
Input impedance at 10 kHz (per pin)	10.4 kΩ - j 11.1 kΩ
Signal transmission	Differential signals
Encoder-ACOPOS electrical isolation	No, common-mode voltage on the sine-cosine inputs max ± 20 V
<b>Environmental conditions</b>	
Temperature	
Operation	
Nominal	5 to 40°C
Maximum	55°C
Storage	-25 to 55°C
Transport	-25 to 70°C
Relative humidity	
Operation	5 to 85%
Storage	5 to 95%
Transport	Max. 95% at 40°C

Table 84: 8AC122.60-3 - Technical data

- 1) The AC122 is an encoder module. Several encoder modules can also be inserted. In this case, the encoder module in the slot with the lowest number is automatically used for motor feedback.
- 2) As default, a resolution of 12 Bit/rev is set, but the resolution can be changed to 14 Bit/rev.
- 3) BRX resolvers are fed with a sine signal (reference signal) from the module and provide two sine signals with a 90° phase shift as a result. The amplitudes of these signals change with the angular position of the resolver. Unlike BRX resolvers, BRT resolvers can be fed with two sine signals which are offset by 90°. A single sine signal with constant amplitude is returned. The phase position of this signal changes with the angular position of the resolver. An evaluation of BRT resolvers with the 8AC122.60-3 is fundamentally possible starting with firmware V2.040; however, resolution and accuracy are limited by the inverse operation of the resolver. Additionally, the nominal conversion ratio deviates from the default value of 0.5 and must be configured accordingly.
- 4) Starting with firmware V2.040, the nominal conversion ratio can be configured in the range from 0.3 ... 0.5 (default value). Starting with firmware V2.230, the nominal conversion ratio can be configured in the range from 0.2 ... 0.5 (default value).

### 3.6.4 Status indicators

The UP/DN LEDs are lit depending on the rotational direction and the speed of the connected encoder.

UP LED ... Lit when the encoder position changes in the positive direction.

DN LED ... Lit when the encoder position changes in the negative direction.

The faster the encoder position changes, the brighter the respective LED is lit.

### 3.6.5 Wiring

#### 3.6.5.1 Pinout

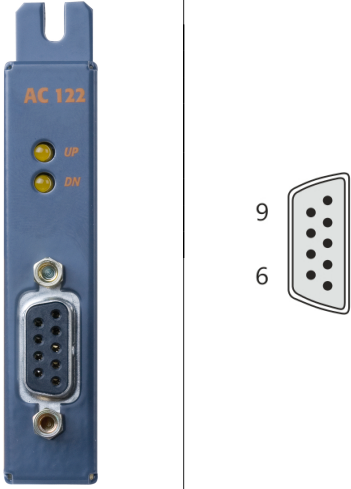
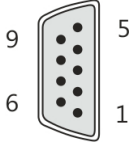
Figure	X11	Pin	Name	Function	Typical wire colors for the resolver
		1	---	---	---
		2	---	---	---
		3	P4	Sine input +	Blue
		4	S1	Cosine input -	Red
		5	R2	Reference output +	black/white (or yellow/white)
		6	---	---	---
		7	S2	Sine input -	Yellow
		8	S3	Cosine input +	Black
		9	R1	Reference output -	red/white

Table 85: AC122 resolver interface - Pinout

### Danger!

The connections for the encoders are isolated circuits. Therefore, these connections are only allowed to be connected to devices or components with at least safe isolation in accordance with IEC 60364-4-41 or EN 61800-5-1.

#### 3.6.5.2 Input/Output circuit diagram

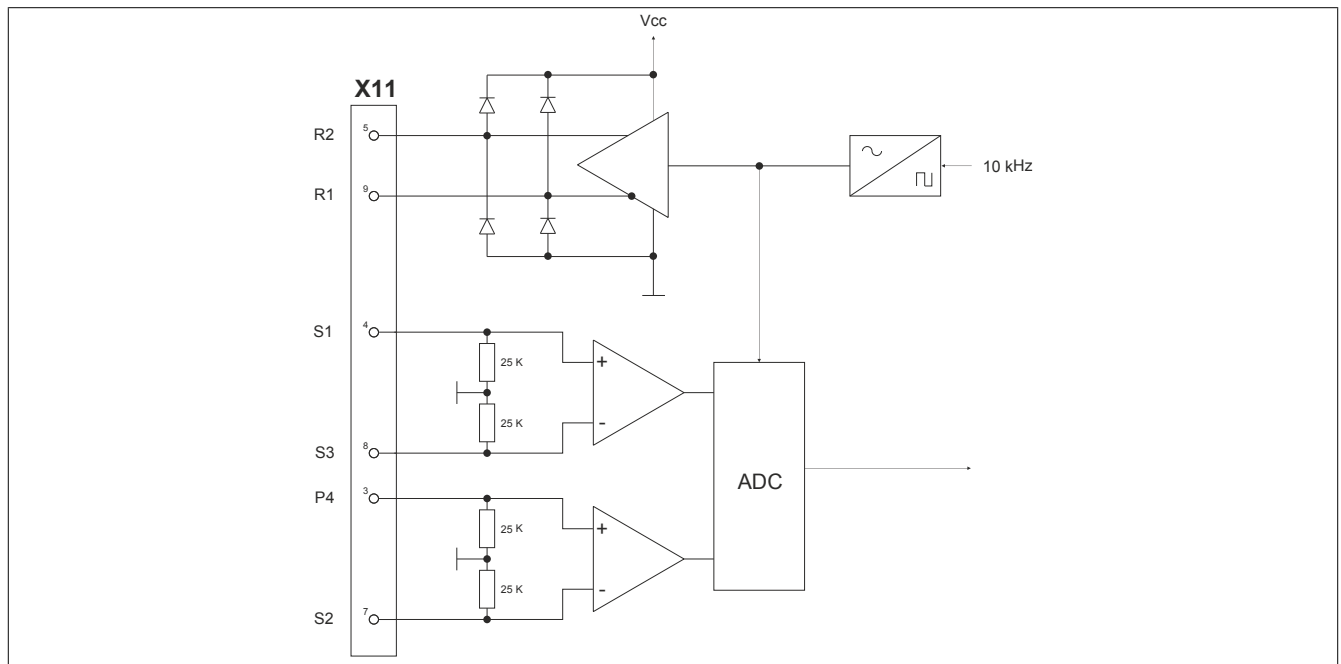


Figure 37: AC122 - Input/Output circuit diagram

### 3.7 AC123 - Incremental encoder and SSI absolute encoder interface

#### 3.7.1 General information

The ACOPOS plug-in module AC123 is used to connect standard industrial incremental or absolute encoders with a synchronous serial interface (SSI) to ACOPOS servo drives. For example, this allows electronic gears to be configured which read master movements using external encoders. If the encoder resolution is high enough, motor feedback for induction motors is also possible.

With incremental encoders, the maximum counter frequency is 200kHz. Single and multi-turn encoders with a maximum of 31 bits at 200 kBaud can be read as absolute SSI encoders.

The position is determined cyclically (initiated by the module) and is exactly synchronized with the ACOPOS controller clock. The input signals are monitored for both encoder types. This makes it possible to detect open or shorted lines as well as encoder supply failures.

With incremental encoders the counter frequency and distance between edges is also monitored. With absolute encoders, the parity bit is evaluated and a plausibility check carried out.

#### 3.7.2 Order data


Model number	Short description	Figure
	<b>Plug-in modules</b>	
8AC123.60-1	ACOPOS plug-in module, incremental encoder and SSI absolute encoder interface	

Table 86: 8AC123.60-1 - Order data

#### 3.7.3 Technical data

Product ID	8AC123.60-1
<b>General information</b>	
Module type	ACOPOS plug-in module
B&R ID code	0x1067
Slot <sup>1)</sup>	Slots 2, 3 and 4
Power consumption	Max. 7.5 W Depends on the current requirements for the encoder connected <sup>2)</sup>
Certification c-UL-us	Yes
<b>Encoder inputs</b>	
Quantity	1
Signal transmission	Differential signal transfer
Module-side connection	15-pin DSUB socket
Status indicators	UP/DN LEDs
Electrical isolation Encoder - ACOPOS	Yes
Encoder monitoring	Yes
Max. encoder cable length <sup>3)</sup>	50 m
<b>Encoder supply</b>	
Short circuit protection, overload protection	Yes
Supply voltages	Internal, select between 5 V / 15 V
Load capability 5 VDC 15 V	350 mA 350 mA
Sense lines For 5 V For 15 V	Yes, 2, compensation of max. 2 V No
<b>Incremental encoder</b>	
Counter size	32-bit
Input frequency	Max. 200 kHz

Table 87: 8AC123.60-1 - Technical data

Product ID	8AC123.60-1
Evaluation	4x
Signal form	Square wave pulse
Counter frequency	Max. 800 kHz
Reference frequency	Max. 200 kHz
Distance between edges	Min. 0.6 μs
Inputs	A, A\, B, B\, R, R\
Differential voltage inputs A, B, R	
Minimum	2.5 V
Maximum	6 V
SSI absolute encoder	
Keying	Gray, binary
Baud rate	200 kbit/s
Word size	Max. 31-bit
Differential voltage clock output - 120 Ω	
Minimum	2.5 V
Maximum	5 V
Differential voltage data input	
Minimum	2.5 V
Maximum	6 V
Environmental conditions	
Temperature	
Operation	
Nominal	5 to 40°C
Maximum	55°C
Storage	-25 to 55°C
Transport	-25 to 70°C
Relative humidity	
Operation	5 to 85%
Storage	5 to 95%
Transport	Max. 95% at 40°C

Table 87: 8AC123.60-1 - Technical data

- The AC123 is an encoder module. Several encoder modules can also be inserted. In this case, the encoder module in the slot with the lowest number is automatically used for motor feedback.
- The power consumption of the plug-in module can be approximated using the following formula:  

$$P_{\text{Module}} [\text{W}] = P_{\text{Encoder}} [\text{W}] \cdot k + 0.6 \text{ W}$$
 The power consumed by the encoder  $P_{\text{Encoder}}$  is calculated from the selected encoder supply voltage (5 V / 15 V) and the current required:  

$$P_{\text{Encoder}} [\text{W}] = U_{\text{Encoder}} [\text{V}] \cdot I_{\text{Encoder}} [\text{A}]$$
 The following values must be used for k:  
 k = 1.2 (for 15 V encoder supply)  
 k = 1.75 (for 5 V encoder supply)
- For the maximum cable length, at least one 4x 2x 0.14 mm<sup>2</sup> + 2x 0.5 mm<sup>2</sup> cable is required. The sense lines must be used.

### 3.7.4 Status indicators

The UP/DN LEDs are lit depending on the rotational direction and the speed of the connected encoder.

UP LED ... Lit when the encoder position changes in the positive direction.

DN LED ... Lit when the encoder position changes in the negative direction.

The faster the encoder position changes, the brighter the respective LED is lit.

### 3.7.5 Firmware

The firmware is part of the operating system for the ACOPOS servo drives. Firmware is updated by updating the ACOPOS operating system.

### 3.7.6 Wiring

#### 3.7.6.1 Pinout

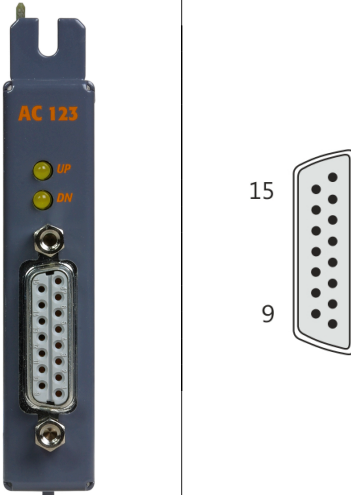
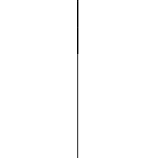
Figure	X11	Pin	Name	Function	
				Incremental mode	SSI mode
		1	A	Channel A	---
		2	A\	Channel A inverted	---
		3	B	Channel B	---
		4	B\	Channel B inverted	---
		5	RD	Reference pulse	Data input
		6	RD\	Reference pulse inverted	Data input inverted
		7	T	---	Clock output
		8	T\	---	Clock output inverted
		9	+5V out / 0.35A	Encoder supply +5 V	
		10	Sense +5V	Sense +5V	
		11	Sense COM	Sense 0V	
		12	COM (7 - 9, 13)	Encoder supply 0 V	
		13	+15V out / 0.35A	Encoder supply +15 V	
		14	A1	Activate encoder supply <sup>1)</sup>	
		15	A2	Activate encoder supply <sup>1)</sup>	

Table 88: AC123 incremental encoder and SSI absolute encoder interface - Pinout

- 1) To activate the encoder supply, pins 14 and 15 must be connected in the encoder cable connector.  
**Caution:** To read from SSI encoders, the encoder supply also has to be activated if the encoder is supplied externally!

## Danger!

The connections for the encoders are isolated circuits. Therefore, these connections are only allowed to be connected to devices or components with at least safe isolation in accordance with IEC 60364-4-41 or EN 61800-5-1.

### 3.7.6.2 Input/Output circuit diagram

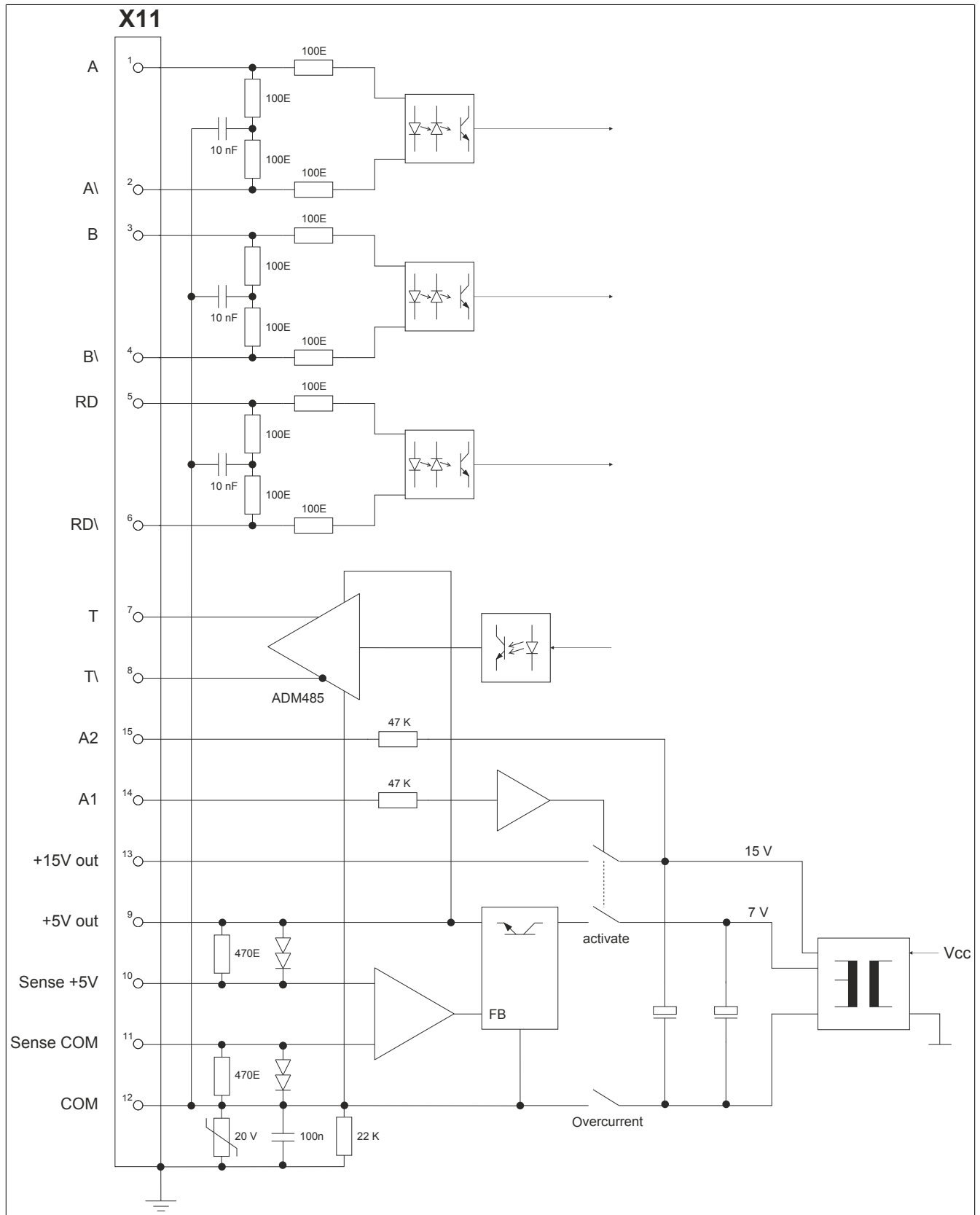


Figure 38: AC123 - Input/Output circuit diagram

### 3.8 AC125 - BiSS encoder interface

#### 3.8.1 General information

The AC125 plug-in module can be used in an ACOPOS slot. The module has a BiSS encoder interface (MODE C) with a baud rate of 6.25 Mbit/s. BiSS encoders with a supply voltage of 5 V can be connected.

This plug-in module can be used to evaluate encoders installed in B&R servo motors as well as encoders for external axes (encoders that scan any machine movement). The input signals are monitored. This makes it possible to detect open or shorted lines as well as encoder supply failures.

#### 3.8.2 Order data


Model number	Short description	Figure
	<b>Plug-in modules</b>	
8AC125.60-1	ACOPOS plug-in module, BiSS encoder interface 5V	

Table 89: 8AC125.60-1 - Order data

#### 3.8.3 Technical data

Product ID	8AC125.60-1
<b>General information</b>	
Module type	ACOPOS plug-in module
B&R ID code	0xACF3
Slot <sup>1)</sup>	Slots 2, 3 and 4
Power consumption	In preparation
Certification c-UL-us	Yes
<b>Encoder inputs <sup>2)</sup></b>	
Quantity	1
Type	BiSS
Module-side connection	15-pin DSUB socket
Status indicators	UP/DN LEDs
Electrical isolation Encoder - ACOPOS	No
Encoder monitoring	Yes
Encoder supply Output voltage Load capability Sense lines	Typ. 5 V 250 mA <sup>3)</sup> No
Reference input Signal transmission Differential voltage for low Differential voltage for high Common-mode voltage Terminating resistor	Differential signal, symmetric ≤ -0.2 V ≥ +0.2 V Max. ±7 V 120 Ω
Serial interface Signal transmission Protocol Baud rate	Synchronous RS485 1250 kBaud
<b>Environmental conditions</b>	
Temperature Operation Nominal Maximum Storage Transport	5 to 40°C 55°C -20 to 55°C -25 to 70°C

Table 90: 8AC125.60-1 - Technical data

Product ID	8AC125.60-1
Relative humidity	
Operation	5 to 85%
Storage	5 to 95%
Transport	Max. 95% at 40°C

Table 90: 8AC125.60-1 - Technical data

- 1) The AC125 is an encoder module. Several encoder modules can also be inserted. In this case, the encoder module in the slot with the lowest number is automatically used for motor feedback.
- 2) The BiSS encoder must be wired using a cable with a single shielding layer.
- 3) This value only applies to the encoder. The actual load capacity of the encoder supply is approx. 300 mA. The difference of approx. 50 mA covers the consumption of the terminating resistors that are always present. For longer encoder cables, it is important to note that the maximum voltage drop permitted on the supply wires (there and back) is 1.45 V. This can reduce the permissible load current.

### 3.8.4 Status indicators

The UP/DN LEDs are lit depending on the rotational direction and the speed of the connected encoder.

UP LED ... Lit when the encoder position changes in the positive direction.

DN LED ... Lit when the encoder position changes in the negative direction.

The faster the encoder position changes, the brighter the respective LED is lit.

### 3.8.5 Firmware

The firmware is part of the operating system for the ACOPOS servo drives. Firmware is updated by updating the ACOPOS operating system.

### 3.8.6 Wiring

#### 3.8.6.1 Pinout

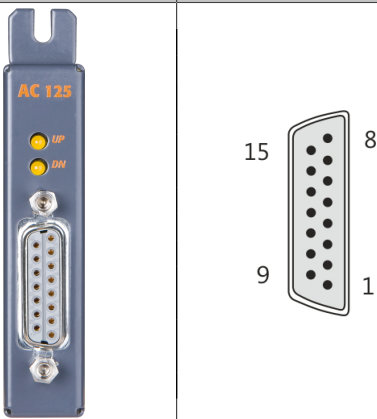
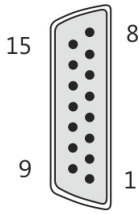
Figure	X11	Pin	Name	Function
		1	A	Channel A
		2	COM (1, 3 - 9, 11, 13 - 15)	Encoder supply 0 V
		3	B	Channel B
		4	+5V out / 0.25A	Encoder supply +5 V
		5	D	Data input
		6	---	---
		7	R\	---
		8	T	Clock output
		9	A\	Channel A inverted
		10	---	---
		11	B\	Channel B inverted
		12	---	---
		13	D\	Data inverted
		14	R	---
		15	T\	Clock output inverted

Table 91: AC125 BiSS encoder interface - Pinout

## Danger!

The connections for the encoders are isolated circuits. Therefore, these connections are only allowed to be connected to devices or components with at least safe isolation in accordance with IEC 60364-4-41 or EN 61800-5-1.

### 3.9 AC126 - EnDat 2.2 interface

#### 3.9.1 General information

- EnDat 2.2 encoder interface for installation in ACOPOS servo drives
- Encoder monitoring
- Embedded parameter chip when used with B&R motors
- Backup battery possible

#### 3.9.2 Order data


Model number	Short description	Figure
	<b>Plug-in modules</b>	
8AC126.60-1	ACOPOS plug-in module, EnDat 2.2 encoder interface	
	<b>Required accessories</b>	
	<b>EnDat 2.2 cables</b>	
8BCF0005.1221B-0	EnDat 2.2 cable, length 5 m, 1x 0.14 mm <sup>2</sup> + 4x 0.34 mm <sup>2</sup> , 12-pin SpringTec EnDat connector, 9-pin DSUB servo connector, can be used in cable drag chains, UL/CSA listed	
8BCF0007.1221B-0	EnDat 2.2 cable, length 7 m, 1x 0.14 mm <sup>2</sup> + 4x 0.34 mm <sup>2</sup> , 12-pin SpringTec EnDat connector, 9-pin DSUB servo connector, can be used in cable drag chains, UL/CSA listed	
8BCF0010.1221B-0	EnDat 2.2 cable, length 10 m, 1x 0.14 mm <sup>2</sup> + 4x 0.34 mm <sup>2</sup> , 12-pin SpringTec EnDat connector, 9-pin DSUB servo connector, can be used in cable drag chains, UL/CSA listed	
8BCF0015.1221B-0	EnDat 2.2 cable, length 15 m, 1x 0.14 mm <sup>2</sup> + 4x 0.34 mm <sup>2</sup> , 12-pin SpringTec EnDat connector, 9-pin DSUB servo connector, can be used in cable drag chains, UL/CSA listed	
8BCF0020.1221B-0	EnDat 2.2 cable, length 20 m, 1x 0.14 mm <sup>2</sup> + 4x 0.34 mm <sup>2</sup> , 12-pin SpringTec EnDat connector, 9-pin DSUB servo connector, can be used in cable drag chains, UL/CSA listed	
8BCF0025.1221B-0	EnDat 2.2 cable, length 25 m, 1x 0.14 mm <sup>2</sup> + 4x 0.34 mm <sup>2</sup> , 12-pin SpringTec EnDat connector, 9-pin DSUB servo connector, can be used in cable drag chains, UL/CSA listed	
	<b>Optional accessories</b>	
	<b>Battery Modules</b>	
8AXB000.0000-00	8AC126.60-1 accessory set for encoder buffering consisting of: 1x lithium battery 3.6 V, 1x battery holder	

Table 92: 8AC126.60-1 - Order data

#### 3.9.3 Technical data

Product ID	8AC126.60-1
<b>General information</b>	
Module type	ACOPOS plug-in module
B&R ID code	0xBD5A
Slot <sup>1)</sup>	Slots 2, 3 and 4
Max. power consumption	In preparation
Certification c-UL-us	In preparation
<b>Encoder connection <sup>2)</sup></b>	
Module-side connection	9-pin DSUB socket
Status indicators	UP/DN LEDs, BAT LED
Electrical isolation Encoder - ACOPOS	No
Encoder monitoring	Yes
Max. encoder cable length	Depending on the cross section of the supply wires on the encoder cable <sup>3)</sup>
<b>Encoder supply</b>	
Output voltage	Typ. 12 V
Load capability	350 mA
Protective measures Overload protection Short circuit protection	Yes Yes
<b>Synchronous serial interface</b>	
Signal transmission	RS485
Baud rate	6.25 Mbit/s

Table 93: 8AC126.60-1 - Technical data

Product ID	8AC126.60-1
<b>Environmental conditions</b>	
Temperature	
Operation	
Nominal	5 to 40°C
Maximum	55°C
Storage	-25 to 55°C
Transport	-25 to 70°C
Relative humidity	
Operation	5 to 85%
Storage	5 to 95%
Transport	Max. 95% at 40°C

Table 93: 8AC126.60-1 - Technical data

- 1) The AC126 is an encoder module. Several encoder modules can also be inserted. In this case, the encoder module in the slot with the lowest number is automatically used for motor feedback.
- 2) B&R 8BCF EnDat 2.2 cables must be used when cabling the module.
- 3) Maximum encoder cable length  $l_{\max}$  can be calculated as follows (the maximum permissible encoder length of 100 m must not be exceeded):

$$l_{\max} = 2.5 \cdot A / [(I_G + 0.03) \cdot \rho]$$

$I_G$  ... Max. current consumption of the encoder [A]

$A$  ... Cross section of the supply wire [mm<sup>2</sup>]

$\rho$  ... Specific resistance [ $\Omega$ mm<sup>2</sup>/m] (e.g. for copper:  $\rho = 0.0178$ )

### 3.9.4 Status indicators

#### UP/DN LEDs

The UP/DN LEDs are lit depending on the rotational direction and the speed of the connected encoder.

UP LED ... Lit when the encoder position changes in the positive direction.

DN LED ... Lit when the encoder position changes in the negative direction.

The faster the encoder position changes, the brighter the respective LED is lit.

#### BAT LED

The BAT LED is used to monitor the backup battery used for battery-backed EnDat 2.2 multi-turn encoders. With these encoders, the multi-turn function is not implemented using a mechanical gearbox; instead, it is implemented using an electronic counter. The electronics must be supplied with power by the backup battery during a power failure.

Color	Description	
Green/Red	Green (lit)	Backup battery OK
	Red (lit)	Backup battery voltage too low or line break
	LED not lit	No encoders with backup batteries present

Table 94: BAT Status LED - AC126

### 3.9.5 Firmware

The firmware is part of the operating system for the ACOPOS servo drives. Firmware is updated by updating the ACOPOS operating system.

### 3.9.6 Wiring

#### 3.9.6.1 Pinout

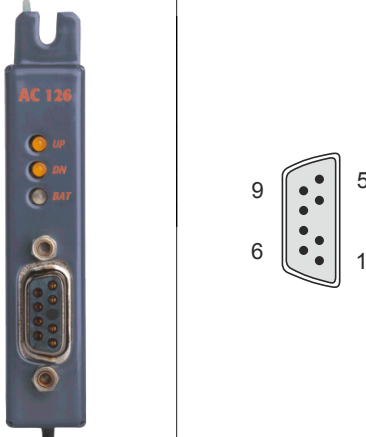
Figure	X11	Pin	Name	Function
 <p>The figure shows the AC 126 module on the left and a diagram of the X11 connector on the right. The X11 connector is a 9-pin D-sub connector with pins numbered 1 through 9. Pin 1 is at the bottom right, pin 5 is at the top right, pin 9 is at the top left, and pin 6 is at the bottom left.</p>		1	U+	Encoder supply +12 V
		2	VBATT	Battery output 3.6 V
		3	---	Coding
		4	D	Data input / output
		5	T	Clock output
		6	COM (1)	Encoder supply 0 V
		7	COM (2)	Battery output 0 V
		8	D\	Data input / output inverted
		9	T\	Clock output inverted

Table 95: AC126 EnDat 2.2 interface - Pinout

### Danger!

The connections for the encoders are isolated circuits. Therefore, these connections are only allowed to be connected to devices or components with at least safe isolation in accordance with IEC 60364-4-41 or EN 61800-5-1.

### Information:

If an encoder that requires a backup battery is connected, pins 2 and 7 must be wired to the encoder and a 8AXB000.0000-00 battery module must be used.

### 3.10 AC130 - Digital mixed module

#### 3.10.1 General information

The AC130 plug-in module can be used in an ACOPOS slot. A maximum of 8 digital inputs or 10 digital outputs are available.

I/O points can be configured in pairs as inputs or outputs. The first three inputs have incremental encoder functionality (A, B, R).

The inputs are divided into 4 standard (max. 10 kHz) and 4 high speed (max. 100 kHz) inputs.

The outputs include 4 high speed (push-pull) outputs with a maximum current of 100 mA, 4 standard (high-side) outputs with a maximum current of 400 mA and 2 low speed (high-side) outputs with a maximum current of 2 A. All outputs can be read.

#### 3.10.2 Order data


Model number	Short description	Figure
	<b>Plug-in modules</b>	
8AC130.60-1	ACOPOS plug-in module, 8 digital I/O configurable in pairs as 24 V input or as output 400/100 mA, 2 digital outputs 2 A, order TB712 terminal block separately.	
	<b>Required accessories</b>	
	<b>Terminal blocks</b>	
7TB712:90-02	2003 B&R terminal block, 12 pin 20 pieces, screw clamp	
7TB712:91-02	2003 B&R terminal block, 12 pin 20 pieces, cage clamp	
7TB712.9	Accessory terminal block, 12-pin, screw clamp 1.5 mm <sup>2</sup>	
7TB712.91	Accessory terminal block, 12-pin, cage clamp 1.5 mm <sup>2</sup>	

Table 96: 8AC130.60-1 - Order data

#### 3.10.3 Technical data

Product ID	8AC130.60-1
<b>General information</b>	
Module type	ACOPOS plug-in module
B&R ID code	0x1068
Slot <sup>1)</sup>	Slots 2, 3 and 4
Power consumption	Max. 0.8 W
Certification c-UL-us	Yes
<b>Inputs/Outputs</b>	
Module-side connection	12-pin connector
Status indicators	24 V LED
Configuration of digital inputs/outputs	Configured in pairs as input or output
<b>Incremental encoder</b>	
Counter size	16-bit
Input frequency	Max. 62.5 kHz
Evaluation	4x
Signal form	Square wave pulse
Encoder monitoring	No
Counter frequency	Max. 250 kHz
Reference frequency	Max. 62.5 kHz
Distance between edges	Min. 2.5 μs
Inputs Input 1 Input 2 Input 3	Channel A Channel B Reference pulse R
<b>Supply voltage</b>	
Voltage monitoring (24 V - LED)	Yes, supply voltage >18 V
Reverse polarity protection	Yes
Supply voltage Minimum Nominal Maximum	18 VDC 24 VDC 30 VDC
<b>Digital inputs <sup>2)</sup></b>	
Quantity	Max. 8

Table 97: 8AC130.60-1 - Technical data

Product ID	8AC130.60-1
Wiring	Sink
Switching threshold	
Low	<5 V
High	>15 V
Input voltage	
Nominal	24 VDC
Maximum	30 VDC
Input current at nominal voltage	
Channel 1-4	Approx. 10 mA
Channel 5-8	Approx. 5.5 mA
Electrical isolation	
Channel - ACOPOS	Yes
Channel - Channel	No
Switching delay	
Channel 1-4	Max. 5 $\mu$ s
Channel 5-8	Max. 35 $\mu$ s
<b>Event counter</b>	
Signal form	Square wave pulse
Input frequency	Max. 100 kHz
Counter size	16-bit
Inputs	
Input 1	Counter 1
Input 2	Counter 2
<b>Digital outputs</b>	
Quantity	Max. 10
Readable outputs	Yes
Continuous current	
Outputs 1 - 4	Max. 100 mA
Outputs 5 - 8	Max. 400 mA
Outputs 9 - 10	Max. 2 A
Short circuit current at 24 V (until cutoff)	
Outputs 1 - 4	Approx. 1 A
Outputs 5 - 8	Approx. 1.2 A
Outputs 9 - 10	Approx. 24 A
Electrical isolation	
Output - ACOPOS	Yes
Output - Output	No
Switching frequency (resistive load)	
Outputs 1 - 2	Max. 10 kHz
Outputs 3 - 4	Max. 10 kHz
Outputs 5 - 8	Max. 5 kHz
Outputs 9 - 10	Max. 100 Hz
Switching voltage	
Minimum	18 VDC
Nominal	24 VDC
Maximum	30 VDC
Switching delay 0 -> 1 and 1 -> 0	
Outputs 1 - 4	Max. 5 $\mu$ s
Outputs 5 - 8	Max. 50 $\mu$ s
Outputs 9 - 10	Max. 500 $\mu$ s
Protection	
Short circuit protection	Yes
Overload protection	Yes
Type	
Outputs 1 - 4	Transistor outputs push-pull
Outputs 5 - 10	High-side transistor outputs
<b>Environmental conditions</b>	
Temperature	
Operation	
Nominal	5 to 40°C
Maximum	55°C
Storage	-25 to 55°C
Transport	-25 to 70°C
Relative humidity	
Operation	5 to 85%
Storage	5 to 95%
Transport	Max. 95% at 40°C

Table 97: 8AC130.60-1 - Technical data

- 1) The AC130 can also be used as an encoder module. Several encoder modules can also be inserted. In this case, the encoder module in the slot with the lowest number is automatically used for motor feedback.
- 2) Shielded cables must be used for inputs 1 - 4.

### 3.10.4 Status indicators

The 24V LED is lit as soon as the supply voltage for the plug-in module goes above 18 VDC.

### 3.10.5 Firmware

The firmware is part of the operating system for the ACOPOS servo drives. Firmware is updated by updating the ACOPOS operating system.

### 3.10.6 Wiring

#### 3.10.6.1 Pinout


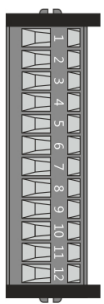
Figure	X11	Pin	Name	Function
		1	Digital I/O 1	Digital input/output 1
		2	Digital I/O 2	Digital input/output 2
		3	Digital I/O 3	Digital input/output 3
		4	Digital I/O 4	Digital input/output 4
		5	Digital I/O 5	Digital input/output 5
		6	Digital I/O 6	Digital input/output 6
		7	Digital I/O 7	Digital input/output 7
		8	Digital I/O 8	Digital input/output 8
		9	Digital O 9	Digital output 9
		10	Digital O 10	Digital output 10
		11	+24 V	+24 V supply
		12	COM (1 - 11)	0 V supply
<b>Terminal cross sections</b>			<b>[mm<sup>2</sup>]</b>	<b>[AWG]</b>
Solid core / multiple-conductor lines			0.5 - 1.5	20 - 14
Flexible, multiple wire line				
Without wire end sleeves			0.5 - 1.5	20 - 14
With wire end sleeves			0.5 - 1.5	20 - 14
Approbation Data (UL/C-UL-US- and CSA) UL/C-UL-US CSA			---	26 - 14 26 - 14
Tightening torque for the terminal screws [Nm]		0.2 ... 0.25		

Table 98: AC130 digital mixed module - Pinout

## Danger!

The digital inputs are isolated circuits. Therefore, these connections are only allowed to be connected to devices or components with at least safe isolation in accordance with IEC 60364-4-41 or EN 61800-5-1.

### 3.10.6.2 Input/Output circuit diagram

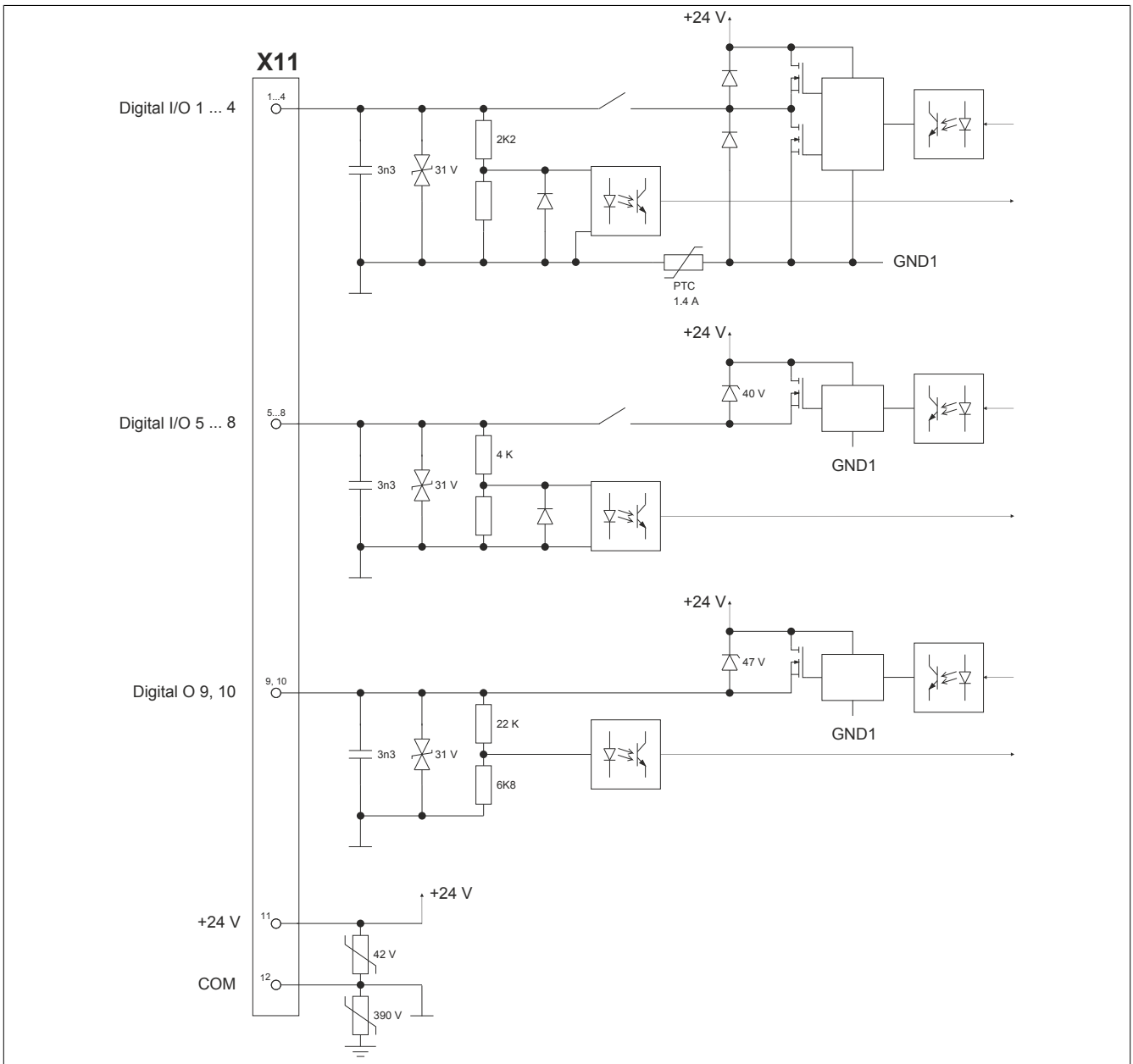


Figure 39: AC130 - Input/Output circuit diagram

## 3.11 AC131 - Mixed module

### 3.11.1 General information

The AC131 plug-in module can be used in an ACOPOS slot. A maximum of 2 analog inputs ( $\pm 10$  V differential inputs or single-ended inputs) and 2 digital inputs or digital outputs are available.

The analog inputs have a resolution of 12 bits and are scanned synchronously using the 50  $\mu$ s clock for the ACOPOS servo drive. The analog inputs have a 10 kHz analog input filter (3rd order low pass).

The digital inputs and outputs can be configured individually as input or output. The digital inputs are equipped with a counter function. The digital outputs (push-pull) can be read.

### 3.11.2 Order data


Model number	Short description	Figure
	<b>Plug-in modules</b>	
8AC131.60-1	ACOPOS plug-in module, 2 analog inputs $\pm 10$ V, 2 digital I/O configurable as 24 V input or output 45 mA, order TB712 terminal block separately.	
	<b>Required accessories</b>	
	<b>Terminal blocks</b>	
7TB712:90-02	2003 B&R terminal block, 12 pin 20 pieces, screw clamp	
7TB712:91-02	2003 B&R terminal block, 12 pin 20 pieces, cage clamp	
7TB712.9	Accessory terminal block, 12-pin, screw clamp 1.5 mm <sup>2</sup>	
7TB712.91	Accessory terminal block, 12-pin, cage clamp 1.5 mm <sup>2</sup>	

Table 99: 8AC131.60-1 - Order data

### 3.11.3 Technical data

Product ID	8AC131.60-1
<b>General information</b>	
Module type	ACOPOS plug-in module
B&R ID code	0x11E9
Slot	Slots 2, 3 and 4
Power consumption	Max. 1 W
Certification c-UL-us	Yes
<b>Inputs/Outputs</b>	
Module-side connection	12-pin connector
Status indicators	24 V LED
Configuration of digital inputs/outputs	Can be configured individually as digital input or output
<b>Supply voltage</b>	
Voltage monitoring (24 V - LED)	Yes, supply voltage >18 V
Reverse polarity protection	Yes
Supply voltage	
Minimum	18 VDC
Nominal	24 VDC
Maximum	30 VDC
<b>Digital inputs</b>	
Quantity	Max. 2
Modulation compared to ground potential	Max. $\pm 50$ V
Wiring	Sink
Input current at nominal voltage	Approx. 8 mA
Switching threshold	
Low	<5 V
High	>15 V
Input voltage	
Nominal	24 VDC
Maximum	30 VDC
Electrical isolation	
Channel - ACOPOS	Yes
Channel - Channel	No
Switching delay	
Counters	Max. 5 $\mu$ s
Digital input	Max. 55 $\mu$ s (digitally filtered)

Table 100: 8AC131.60-1 - Technical data

Product ID	8AC131.60-1
<b>Event counter</b>	
Signal form	Square wave pulse
Input frequency	Max. 100 kHz
Counter size	16-bit
Inputs	
Input 1	Counter 1
Input 2	Counter 2
<b>Analog inputs</b>	
Quantity	2
Digital converter resolution	12-bit
Conversion time	<50 µs
Output format	INT16 \$8000 - \$7FF0 LSB = \$0010 = 4.883 mV
Design	Differential input or single ended input
Electrical isolation	
Input - ACOPOS	Yes
Input - Input	No
Input signal	
Nominal	-10 to +10 V
Maximum	-15 to +15 V
Operating modes	Cyclic measurement synchronous to 50 µs ACOPOS clock
Conversion procedure	Successive approximation
Input filter	Analog 3rd order low pass / cut-off frequency: 10 kHz
Gain drift	Max. ±0.006% / °C <sup>1)</sup>
Offset drift	Max. ±0.0005% / °C <sup>1)</sup>
Common-mode rejection	
DC	Min. -73 dB
50 Hz	Min. -73 dB
Crosstalk between analog inputs	Min. -90 dB at 1kHz
Non-linearity	±1 LSB
Differential input impedance	>10 MΩ
Modulation compared to ground potential	Max. ±50 V
Modulation between analog input channels	Max. ±5 V
Basic accuracy at 25°C	Refers to the measurement range limit ±0.05% <sup>1)</sup>
<b>Environmental conditions</b>	
Temperature	
Operation	
Nominal	5 to 40°C
Maximum	55°C
Storage	-25 to 55°C
Transport	-25 to 70°C
Relative humidity	
Operation	5 to 85%
Storage	5 to 95%
Transport	Max. 95% at 40°C

Table 100: 8AC131.60-1 - Technical data

1) Refers to the measurement range limit

### 3.11.4 Status indicators

The 24V LED is lit as soon as the supply voltage for the plug-in module goes above 18 VDC.

### 3.11.5 Firmware

The firmware is part of the operating system for the ACOPOS servo drives. Firmware is updated by updating the ACOPOS operating system.

### 3.11.6 Wiring

#### 3.11.6.1 Pinout


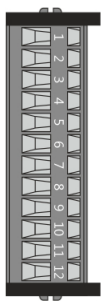
Figure	X11	Pin	Name	Function
		1	Analog I 1 +	Analog input 1 plus
		2	Analog I 1 -	Analog input 1 minus
		3	COM (1, 2, 5, 6)	0 V analog input
		4	Shield	Shield
		5	Analog I 2 +	Analog input 2 plus
		6	Analog I 2 -	Analog input 2 minus
		7	COM (1, 2, 5, 6)	0 V analog input
		8	Shield	Shield
		9	Digital I/O 1	Digital input/output 1
		10	Digital I/O 2	Digital input/output 2
		11	+24 V	+24 V supply
		12	COM (9 - 11)	0 V supply
<b>Terminal cross sections</b>			<b>[mm<sup>2</sup>]</b>	<b>[AWG]</b>
Solid core / multiple-conductor lines			0.5 - 1.5	20 - 14
Flexible, multiple wire line				
Without wire end sleeves			0.5 - 1.5	20 - 14
With wire end sleeves			0.5 - 1.5	20 - 14
Approbation Data (UL/C-UL-US- and CSA) UL/C-UL-US CSA			---	26 - 14 26 - 14
Tightening torque for the terminal screws [Nm]			0.2 ... 0.25	

Table 101: AC131 mixed module - Pinout

3.11.6.2 Input/Output circuit diagram

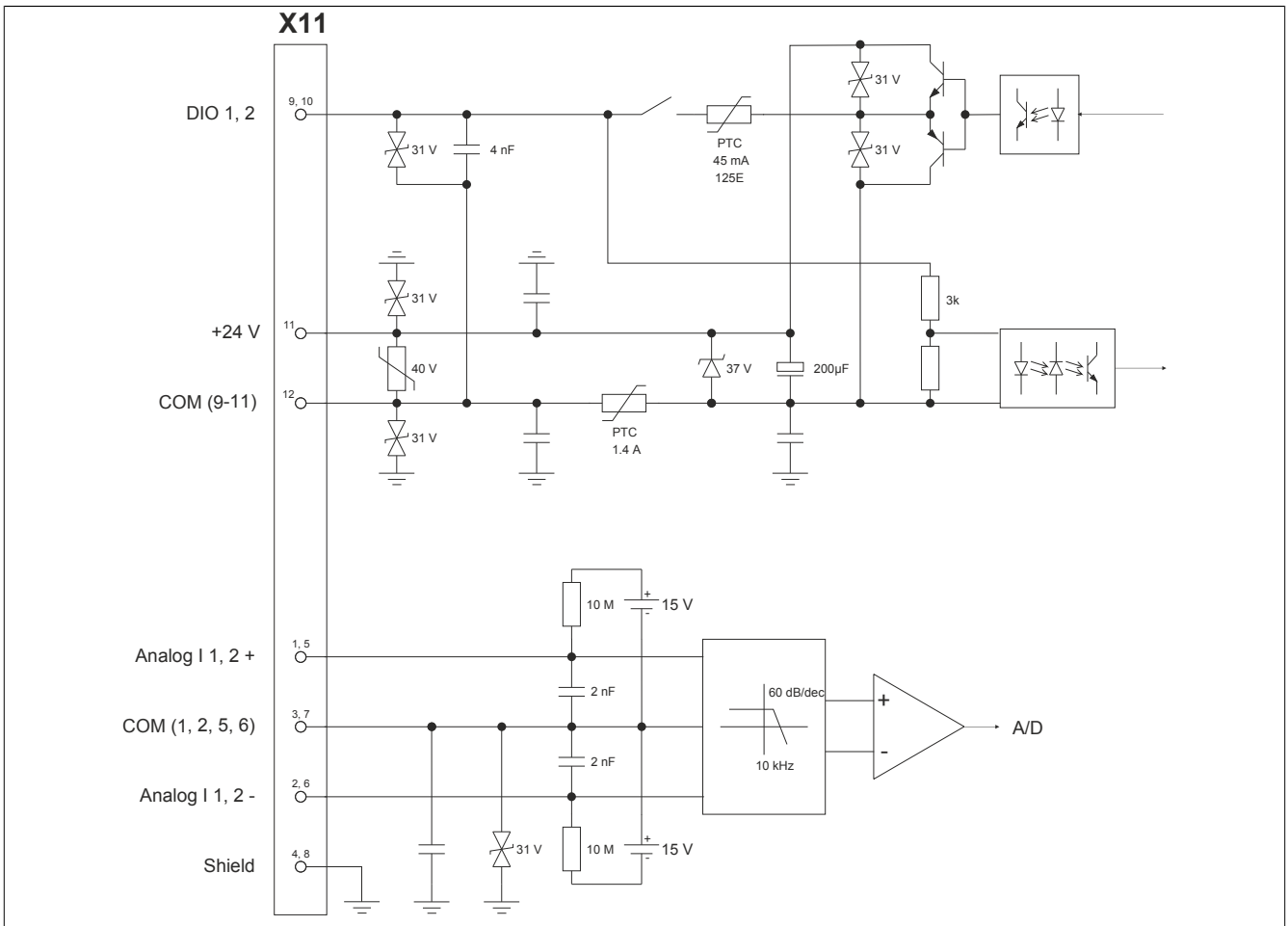


Figure 40: AC131 - Input/Output circuit diagram

## 3.12 AC140 - CPU module

### 3.12.1 General information

The AC110 plug-in module can be used in an ACOPOS slot (requires two slots).

The CPU module makes it possible to operate an ACOPOS servo drive without an external PLC and is also available with an integrated "Soft CNC" system (8AC140.61-3).

Communication in the ACOPOS network occurs as described in the section "Drive-based control" on page 22.

The ACOPOS servo drive in which the AC140 is plugged into is connected via emulation of an AC110 CAN interface plug-in module in slot 1. All other CAN stations are connected via the IF2 CAN interface.

This module offers interchangeable application memory in the form of a CompactFlash card as well as a separate backup battery for the module. <sup>2)</sup>

It is equipped with up to four application interfaces:

- One RS232 interface (IF1) for programming and configuring using B&R Automation Studio™
- One CAN interface (IF2) for connecting to a CAN network
- one PROFIBUS DP slave interface (IF3) for connecting to a PROFIBUS network
- One Ethernet interface (IF6) for connecting to an Ethernet network (only 8AC140.61-3).

In addition, a maximum of three digital inputs / outputs are provided as well as one analog input ( $\pm 10$  V differential input).

The digital inputs and outputs can be configured individually as an input or output. Additional functions such as a counter function with direction switching (stepper motor) or period and gate measurement are integrated. The inputs and outputs are scanned directly by the CPU module; the ACOPOS servo drive does not have direct access to these inputs and outputs.

The analog input has a resolution of 12 bits and an analog input filter with 10 kHz (3rd-order low pass).

### 3.12.2 Order data - 8AC140.60-3


Model number	Short description	Figure
8AC140.60-3	ACOPOS plug-in module, CPU, x86 100 MHz Intel compatible, 32 MB DRAM, 32 kB SRAM, removable program memory: CompactFlash, 1 CAN interface, 1 Ethernet interface 100 Base-T, 1 PROFIBUS DP Slave interface, 1 RS232 interface, 3 digital I/O configurable as 24 VDC input or output 500 mA, 1 analog input $\pm 10$ V, order program memory and 0TB708 terminal block separately.	
	<b>Required accessories</b>	
	<b>CompactFlash</b>	
0CFCRD.0128E.01	Compact Flash 128MB WD extended Temp.	
0CFCRD.0512E.01	Compact Flash 512MB WD extended Temp.	
5CFCRD.0064-03	CompactFlash 64 MB Western Digital (SLC)	
5CFCRD.0128-03	CompactFlash 128 MB Western Digital (SLC)	
5CFCRD.0256-03	CompactFlash 256 MB Western Digital (SLC)	
5CFCRD.0512-03	CompactFlash 512 MB Western Digital (SLC)	
5CFCRD.1024-03	CompactFlash 1 GB Western Digital (SLC)	
5CFCRD.2048-03	CompactFlash 2 GB Western Digital (SLC)	
5CFCRD.4096-03	CompactFlash 4 GB Western Digital (SLC)	
5CFCRD.8192-03	CompactFlash 8 GB Western Digital (SLC)	
	<b>Terminal blocks</b>	
0TB704.91	Accessory terminal block, 4-pin, cage clamp 2.5 mm <sup>2</sup>	
0TB708:91-02	Accessory terminal block, 8 pins, 20 pieces cage clamp 1,5 mm <sup>2</sup>	
0TB708.91	Accessory terminal block, 8-pin, cage clamp 1.5 mm <sup>2</sup>	
	<b>Optional accessories</b>	
	<b>Batteries</b>	
0AC201.91	Lithium batteries 4 pcs., 3 V / 950 mAh button cell We hereby state that the lithium cells contained in this shipment qualify as "partly regulated". Handle with care. If the package is damaged, inspect the cells, repack intact cells and protect the cells against short circuit. For emergency information, call RENATA SA at +41 61 319 28 27.	
	<b>Cables</b>	
0G0001.00-090	PC - PLC/PW cable, RS232, online cable	
	<b>Infrastructure components</b>	

Table 102: 8AC140.60-3 - Order data

<sup>2)</sup> Application memory must be ordered separately.

Model number	Short description	Figure
0AC912.9	Bus adapter, CAN, 1 CAN interface	
0AC913.92	Bus adapter, CAN, 2 CAN interfaces, including 30 cm attachment cable (DSUB)	
7AC911.9	Bus connector, CAN	

Table 102: 8AC140.60-3 - Order data

### 3.12.3 Order data - 8AC140.61-3


Model number	Short description	Figure
	<b>Plug-in modules</b>	
8AC140.61-3	ACOPOS plug-in module, CPU, ARNC0, x86 100 MHz Intel compatible, 32 MB DRAM, 32 kB SRAM, removable program memory: CompactFlash, 1 CAN interface, 1 Ethernet interface 100 Base-T, 1 PROFIBUS DP Slave interface, 1 RS232 interface, 3 digital I/O configurable as 24 VDC input or output 500 mA, 1 analog input $\pm 10$ V, order program memory and 0TB708 terminal block separately.	
	<b>Required accessories</b>	
	<b>CompactFlash</b>	
0CFCRD.0128E.01	Compact Flash 128MB WD extended Temp.	
0CFCRD.0512E.01	Compact Flash 512MB WD extended Temp.	
5CFCRD.0064-03	CompactFlash 64 MB Western Digital (SLC)	
5CFCRD.0128-03	CompactFlash 128 MB Western Digital (SLC)	
5CFCRD.0256-03	CompactFlash 256 MB Western Digital (SLC)	
5CFCRD.0512-03	CompactFlash 512 MB Western Digital (SLC)	
5CFCRD.1024-03	CompactFlash 1 GB Western Digital (SLC)	
5CFCRD.2048-03	CompactFlash 2 GB Western Digital (SLC)	
5CFCRD.4096-03	CompactFlash 4 GB Western Digital (SLC)	
5CFCRD.8192-03	CompactFlash 8 GB Western Digital (SLC)	
	<b>Terminal blocks</b>	
0TB704.9	Accessory terminal block, 4-pin, screw clamp 2.5 mm <sup>2</sup>	
0TB704.91	Accessory terminal block, 4-pin, cage clamp 2.5 mm <sup>2</sup>	
0TB708:91-02	Accessory terminal block, 8 pins, 20 pieces cage clamp 1,5 mm <sup>2</sup>	
0TB708.91	Accessory terminal block, 8-pin, cage clamp 1.5 mm <sup>2</sup>	
	<b>Optional accessories</b>	
	<b>Batteries</b>	
0AC201.91	Lithium batteries 4 pcs., 3 V / 950 mAh button cell We hereby state that the lithium cells contained in this shipment qualify as "partly regulated". Handle with care. If the package is damaged, inspect the cells, repack intact cells and protect the cells against short circuit. For emergency information, call RENATA SA at +41 61 319 28 27.	
	<b>Cables</b>	
0G0001.00-090	PC - PLC/PW cable, RS232, online cable	
	<b>Infrastructure components</b>	
0AC912.9	Bus adapter, CAN, 1 CAN interface	
0AC913.92	Bus adapter, CAN, 2 CAN interfaces, including 30 cm attachment cable (DSUB)	
0G1000.00-090	Bus connector, RS485, for PROFIBUS networks	
7AC911.9	Bus connector, CAN	

Table 103: 8AC140.61-3 - Order data

### 3.12.4 Technical data

Product ID	8AC140.60-3	8AC140.61-3
<b>General information</b>		
Module type	ACOPOS plug-in module double-width	
B&R ID code	0x26D9	0x2276
Slot <sup>1)</sup>	Slots 1 + 2	
Power consumption	Max. 4.5 W	
ACOPOS capability	Yes	
Visual Components support	Yes	
Certification c-UL-us	Yes	
<b>Controller</b>		
Operating system	AC140 (version V2.67 and higher)	
DRAM	32 MB	
Processor clock	100 MHz	
SRAM	32 kB	
<b>Inputs/Outputs</b>		
Module-side connection	8-pin connector	
Configuration of digital inputs/outputs	Can be configured individually as input or output	

Table 104: 8AC140.60-3, 8AC140.61-3 - Technical data

Product ID	8AC140.60-3	8AC140.61-3
<b>Incremental encoder</b>		
Counter size	16-bit	
Input frequency	Max. 20 kHz	
Evaluation	4x	
Signal form	Square wave pulse	
Encoder monitoring	No	
Counter frequency	Max. 80 kHz	
Reference frequency	Max. 20 kHz	
Distance between edges	Min. 5 µs	
Inputs	Channel A Channel B Reference pulse R	
Input 1	Channel A	
Input 2	Channel B	
Input 3	Reference pulse R	
<b>Digital inputs <sup>2)</sup></b>		
Quantity	Max. 3	
Modulation compared to ground potential	Max. ±30 V	
Wiring	Sink	
Input current at nominal voltage	Approx. 4.2 mA	
Input delay	<5 µs	
Switching threshold	Low High	
Low	<5 V	
High	>15 V	
Input voltage	Nominal Maximum	
Nominal	24 VDC	
Maximum	30 VDC	
Electrical isolation	Channel - ACOPOS Channel - Channel	
Channel - ACOPOS	Yes	
Channel - Channel	No	
<b>Event counter</b>		
Signal form	Square wave pulse	
Input frequency	Max. 100 kHz	
Pulse length	Min. 5 µs	
Counter size	32-bit	
Inputs	Input 1	
Input 1	Counter 1	
<b>Gate measurement</b>		
Signal form	Square wave pulse	
Counter frequency	Internal External	
Internal	31.25 kHz or 4 MHz	
External	Max. 100 kHz	
Pulse length	Min. 5 µs	
Gate frequency	Max. 100 kHz	
<b>Period measurement</b>		
Signal form	Square wave pulse	
Input frequency	Max. 100 kHz	
Pulse length	Min. 5 µs	
Counter frequency	Internal External	
Internal	31.25 kHz or 4 MHz	
External	Max. 100 kHz	
<b>Analog inputs</b>		
Digital converter resolution	12-bit	
Conversion time	<50 µs	
Output format	INT 16 \$8001 - \$7FFF LSB = \$0010 = 4.88 mV	
Design	Differential input	
Electrical isolation	Input - ACOPOS <sup>3)</sup>	
Input - ACOPOS <sup>3)</sup>	No, max. modulation: ±13 V	
Input signal	Nominal Maximum	
Nominal	-10 to +10 V	
Maximum	-13 to +13 V	
Operating modes	Cyclic measurement non-synchronous to 50 µs ACOPOS clock	
Conversion procedure	Successive approximation	
Input filter	Analog low pass 3rd-order Cut-off frequency: 10 kHz	
Common-mode rejection	DC 50 Hz	
DC	Min. 73 dB	
50 Hz	Min. 73 dB	
Non-linearity	±2 LSB	
Differential input impedance	20 MΩ	
<b>Digital outputs</b>		
Quantity	Max. 3	
Readable outputs	Yes	
Continuous short circuit current at 24 V	Typ. 4 A	
Continuous current	Max. 500 mA	

Table 104: 8AC140.60-3, 8AC140.61-3 - Technical data

**Technical data • ACOPOS plug-in modules**

<b>Product ID</b>	<b>8AC140.60-3</b>	<b>8AC140.61-3</b>
Switching frequency (resistive load)		Max. 100 Hz
Switching delay		Max. 500 µs (typ. 250 µs)
Type		High-side transistor outputs
Electrical isolation		
Output - ACOPOS		Yes
Output - Output		No
Switching voltage		
Minimum		18 VDC
Nominal		24 VDC
Maximum		30 VDC
Protection		
Short circuit protection		Yes
Overload protection		Yes
<b>Interfaces</b>		
IF1 interface		
Type		RS232
Design		9-pin DSUB plug
Status indicators		X1 LED
Electrical isolation		No
Max. baud rate		115.2 kBaud
Max. distance		15 m / 19,200 baud
IF2 interface		
Type		CAN bus
Design		9-pin DSUB plug
Status indicators		RX / TX LEDs
Bus terminating resistor		Externally wired
Electrical isolation		Yes
Max. distance		1000 m
Network-capable		Yes
Max. transfer rate		
Bus length ≤60 m		500 kbit/s
Bus length ≤200 m		250 kbit/s
Bus length ≤1000 m		50 kbit/s
IF3 interface		
Type		RS485
Design		9-pin DSUB socket
Status indicators		PB LED
Bus terminating resistor		External T-connector
Controller		ASIC SPC3
Electrical isolation		Yes
RAM		1.5 kB
Max. distance		1000 m
Network-capable		Yes
Transfer protocol		PROFIBUS DP
Max. transfer rate		
Bus length ≤100 m		12 Mbit/s
Bus length ≤200 m		1.5 Mbit/s
Bus length ≤400 m		500 kbit/s
Bus length ≤1000 m		187.5 kbit/s
IF5 interface		
Type		Ethernet
Design		RJ45 socket
Status indicators		ACT LED
Baud rate		10/100 Mbit/s
Electrical isolation		Yes
Max. distance		100 m
Network-capable		Yes
<b>Environmental conditions</b>		
Temperature		
Operation		
Nominal		5 to 40°C
Maximum		55°C
Storage		-25 to 55°C
Transport		-25 to 70°C
Relative humidity		
Operation		5 to 85%
Storage		5 to 95%
Transport		Max. 95% at 40°C

**Table 104: 8AC140.60-3, 8AC140.61-3 - Technical data**

- 1) The AC140 is a module with double-width and occupies slots 1 and 2.
- 2) Shielded cables must be used for inputs 1 - 3.
- 3) An external electrical isolation of the connected sensors is recommended because the analog input is not electrically isolated.

### 3.12.5 Status indicators


Figure	LED	Name	Color	Description
	1	Status (RUN)	Red Red with orange blinking Red/green blinking (1 Hz) Orange Green Green with orange blinking	ERROR/RESET Load/unload and start BOOT AR Startup of BOOT or CF - AR SERVICE/DIAG/BOOT mode RUN RUN - BATTERY LOW
	2	RS232 (X1)	Orange blinking	Data transfer to application interface IF1 (RS232)
	3	PROFIBUS (PB)	Orange	Data transfer on application interface IF3 (PROFIBUS)
	4	Ethernet (ACT)	Orange Orange blinking	Ethernet LINK (IF6) Ethernet ACTIVE (IF6)
	5	CAN (RX)	Orange	Receive data on application interface IF2 (CAN)
	6	CAN (TX)	Orange	Send data to application interface IF2 (CAN)

Table 105: 8AC140.60-3, 8AC140.61-3 - Status indicators

### 3.12.6 Setting the CAN station number (IF2)

The CAN station number can be set using two HEX code switches:

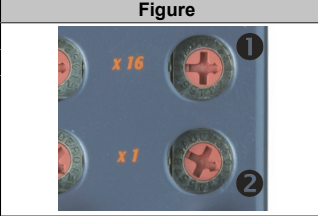
Figure	Switch	Description
	1	CAN station number 16s position (high)
	2	CAN station number 1s position (low)
The settings \$00, and \$FF are reserved for special functions.  <b>\$00:</b> In this switch position, the operating system can be programmed via the online interface. User Flash is only deleted after the update begins.  <b>\$FF:</b> Diagnostics mode.		

Table 106: Setting the CAN station number

A changed CAN station number will take effect the next time the ACOPOS servo drive is switched on.

There must be a terminating resistor (120 Ω, 0.25 W) between CAN\_H and CAN\_L at the beginning and end of the CAN bus.

#### Information:

The CAN bus IF2 is always made up of at least two stations that are integrated in the AC140. These are the AC140 CPU and an AC110 emulation, which the ACOPOS uses for communication. Therefore, the AC140 CPU prevents a potential error in which no other stations are found on the CAN bus. This is why the AC140 CPU does not register a hardware error if there is no physical connection to external CAN devices.

### 3.12.7 Setting the PROFIBUS station number (IF3)

The PROFIBUS station number can be set using two HEX code switches:

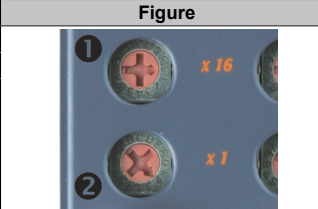
Figure	Switch	Description
	1	PROFIBUS station number 16s position (high)
	2	PROFIBUS station number 1s position (low)

Table 107: Setting the PROFIBUS station number

A changed PROFIBUS station number will take effect the next time the ACOPOS servo drive is switched on.

### 3.12.8 Setting the Ethernet station number (IF6)

The Ethernet station number can be set using software (B&R Automation Studio™).

### 3.12.9 Reset button

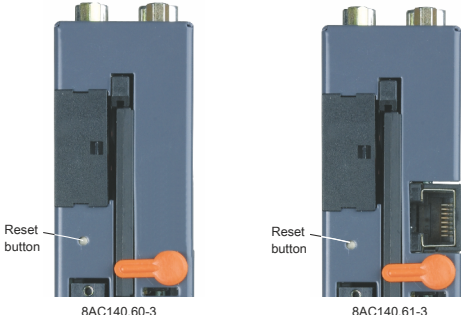
View (view from below)	Description
	<p>The reset button can be pressed with any small pointed object (e.g. paper clip). Pressing the reset button triggers a hardware reset, which means:</p> <ul style="list-style-type: none"> <li>• All application programs are stopped.</li> <li>• All outputs are set to zero.</li> </ul> <p>The AC140 then switches to SERVICE mode.</p>

Table 108: Reset button

### 3.12.10 Slot for application memory (CompactFlash)

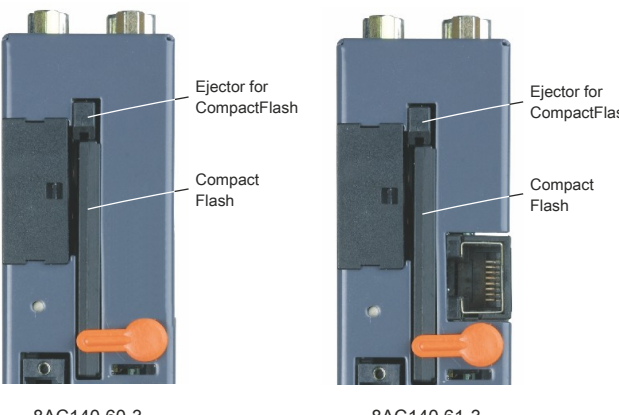
View (view from below)	Description
	<p>Program memory is required to operate the AC140. The application memory is CompactFlash. This is not included with the delivery of the AC140. CompactFlash must be ordered separately as an accessory!</p> <p>The CompactFlash memory card is used in the slot on the bottom of the AC140. Press the eject button to remove the card.</p> <p>The CompactFlash memory card can be secured with the safety clip.</p>

Table 109: Application memory

### 3.12.11 Backup battery

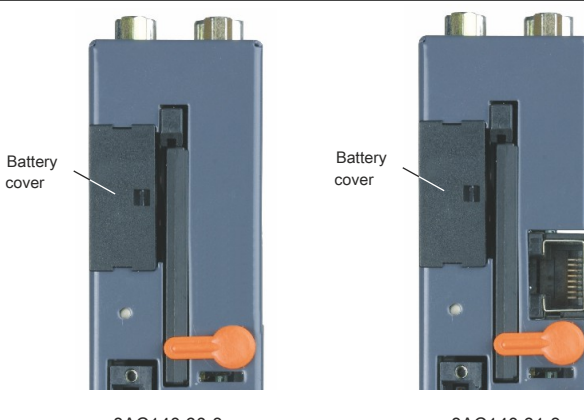
View (view from below)	Description														
	<p>The AC140 is equipped with a lithium battery. The lithium battery is placed in a separate compartment on the bottom of the module and protected by a cover.</p> <table border="1" data-bbox="799 1451 1465 1659"> <thead> <tr> <th colspan="2">Backup battery data</th> </tr> </thead> <tbody> <tr> <td>Lithium battery</td> <td>3V / 950 mAh</td> </tr> <tr> <td>Model number</td> <td>0AC201.91</td> </tr> <tr> <td>Short description</td> <td>Lithium batteries, 4 pcs., 3 V / 950 mAh, button cell</td> </tr> <tr> <td>Storage temperature</td> <td>-20 to +60°C</td> </tr> <tr> <td>Storage time</td> <td>Max. 3 years at 30°C</td> </tr> <tr> <td>Relative humidity</td> <td>0 to 95%, non-condensing</td> </tr> </tbody> </table>	Backup battery data		Lithium battery	3V / 950 mAh	Model number	0AC201.91	Short description	Lithium batteries, 4 pcs., 3 V / 950 mAh, button cell	Storage temperature	-20 to +60°C	Storage time	Max. 3 years at 30°C	Relative humidity	0 to 95%, non-condensing
Backup battery data															
Lithium battery	3V / 950 mAh														
Model number	0AC201.91														
Short description	Lithium batteries, 4 pcs., 3 V / 950 mAh, button cell														
Storage temperature	-20 to +60°C														
Storage time	Max. 3 years at 30°C														
Relative humidity	0 to 95%, non-condensing														

Table 110: Backup battery

## Data / real-time buffering

The following areas are buffered:

- Remanent variables
- User RAM
- System RAM
- Real-time clock

## Battery monitoring

The battery voltage is checked cyclically. The cyclic load test of the battery does not considerably shorten the battery life, instead it gives an early warning of weakened buffer capacity.

The status information "Battery OK" is available from the "BatteryInfo" system library function.

## Battery change interval

### Caution!

The battery should be changed every 4 years. The change intervals refer to the average service life and operating conditions and are recommended by B&R. It is not the maximum buffer duration.

### Information:

Data stored in the AC140 RAM will be lost if the battery is changed with the PLC switched off! The battery can be changed with power applied, but this is not allowed in all countries!

### Warning!

The battery must be replaced by a Type CR2477N Renata battery only. The use of another battery may present a risk of fire or explosion.

The battery may explode if handled improperly. Do not recharge, disassemble or dispose of in fire.

### Procedure for changing the battery

1. Touch the mounting rail or ground connection (not the power supply!) in order to discharge any electrostatic charge from your body.
2. Remove the cover from the lithium battery holder using a screwdriver.

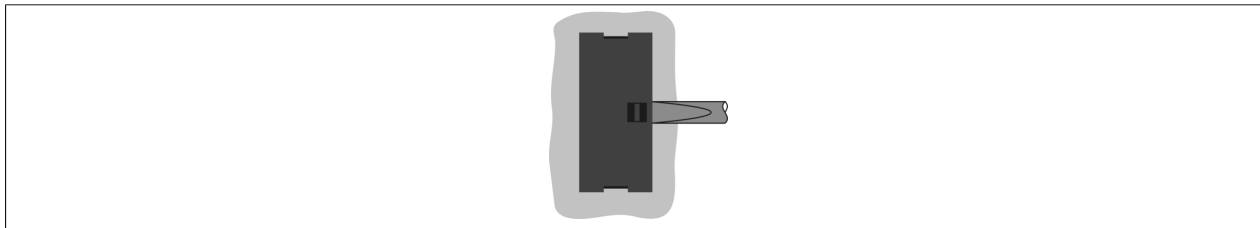


Figure 41: Remove the cover for the lithium battery

3. Remove the battery from the holder by pulling the removal strip (don't use uninsulated tools because of risk of short circuiting). The battery should not be held by its edges. Insulated tweezers may also be used for removing the battery.

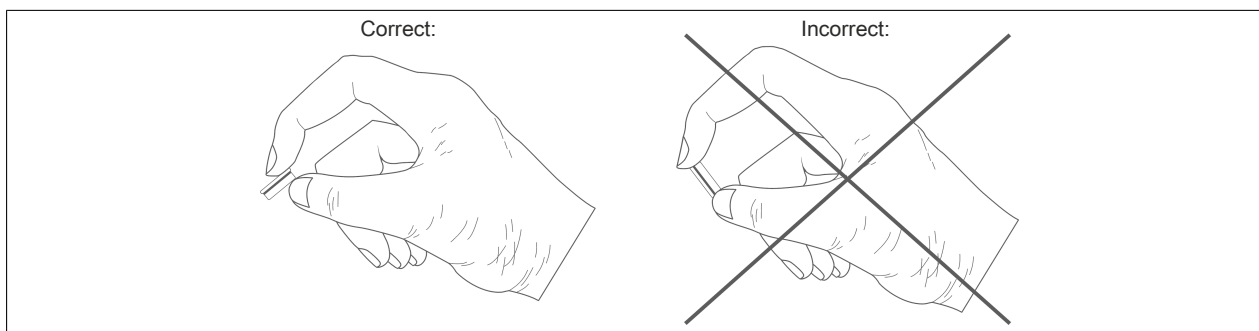


Figure 42: Hold the battery correctly

4. Insert the new battery with correct polarity. The removal strip should be pulled to the right of the battery holder and the "+" side of the battery should be facing left. In order to be able to remove the battery again in future, the removal strip **must be on the right side** of the battery.

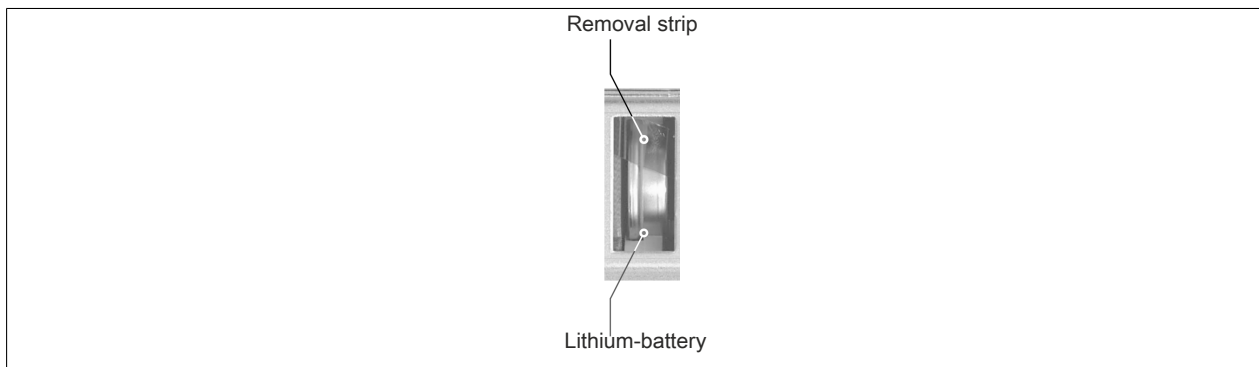


Figure 43: Removal strip should be pulled to the right

5. Now wrap the end of the removal strip over the top of the battery and insert it underneath the battery so that it does not protrude from the battery holder.
6. Replace cover. Insert the lower edge of the cover in the battery holder opening. Press the upper end of the cover home firmly.

### Information:

Lithium batteries are considered hazardous waste. Used batteries should be disposed of appropriately.

### 3.12.12 Input/Output registers

#### Digital in r/- (16-bit):

Bit no.	Value	Description
0		Logical status of digital I/O 1
1		Logical status of digital I/O 2
2		Logical status of digital I/O 3
3 - 15		Reserved

#### Digital out r/w (16-bit):

All reserved bits must be written with 0.

Bit no.	Value	Description
0	0	Digital output 1 inactive
	1	Digital output 1 active
1	0	Digital output 2 inactive
	1	Digital output 2 active
2	0	Digital output 3 inactive
	1	Digital output 3 active
3 - 15		Reserved

#### Analog in (16-bit) r/-:

±10V (12 bit resolution)

#### Counter (32-bit) r(w):

In addition to the typical counter modes, this counter has a "Stepper motor counter mode" (see Configuration register bits 4-6).

In stepper motor counter mode, the count direction is set using digital I/O 2 (0...increment, 1...decrement), and the counter clock is on digital I/O 1. Only one clock edge is used for counting (can be configured with bit 3 of the counter configuration register).

#### Counter configuration (16 bit) r/w:

All reserved bits must be written with 0.

Bit no.	Value	Description
0		Reserved
1	0	AB(R) counter mode: R input disabled
	1	AB(R) counter mode: R input enabled
2		Reserved
3	0	Measurement starts at increasing edge
	1	Measurement starts at falling edge
4 - 6	000	No counter operation
	001	AB(R) counter mode
	010	Event counter mode
	011	Period measurement mode
	100	stepper motor counter mode
	101	Gate measurement mode
	110	Not allowed
	111	Not allowed
7 - 8	00	Counter frequency 4MHz
	01	External counter frequency
	10	Counter frequency 31.25kHz
	11	Not allowed
9	0	Counter overflow recognition disabled / Reset counter overflow bit
	1	Overflow recognition of the continuous counter is enabled (value limited to \$FFFF)
10 - 14		Reserved
15	0	Time / counter reset
	1	Time / counter enabled (ATTENTION: Only set bit after counter configuration is complete)

#### Status (16 Bit) r/- :

Bit no.	Value	Description
0 - 8		Reserved
9	0	Period or gate measurement within the counter range 0 - \$FFFF (only valid if bit 9 is set in the counter configuration word)
	1	Counter overflow during period or gate measurement. Acknowledge by resetting bit 9 of the counter configuration word
10 - 14		Reserved
15	0	Output supply voltage monitoring 24 VDC - OK
	1	Output supply voltage monitoring 24 VDC error

### 3.12.13 Wiring

#### 3.12.13.1 Application interface IF1 (RS232)

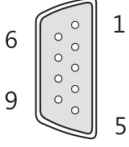
X1	Pin	Name	Function
	1	DCD	Data Carrier Detect
	2	RXD	Receive signal
	3	TXD	Transmit signal
	4	DTR	Data Terminal Ready
	5	GND	Ground
	6	DSR	Data Set Ready
	7	RTS	Request To Send
	8	CTS	Clear To Send
	9	RIN	Ring indicator

Table 111: X1 connector (RS232) - Pinout

#### 3.12.13.2 Application interface IF2 (CAN)

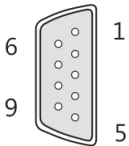
X2	Pin	Name	Function
	1	---	---
	2	CAN_L	CAN low
	3	CAN_GND	CAN 0 V
	4	---	---
	5	---	---
	6	---	---
	7	CAN_H	CAN high
	8	---	---
	9	---	---

Table 112: X2 connector (CAN) - Pinout

#### 3.12.13.3 Application interface IF3 (PROFIBUS)

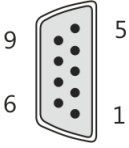
X3	Pin	Name	Function
	1	---	---
	2	---	---
	3	DATA	Data
	4	CNTRL	Transmit enable
	5	PROFIBUS_GND	PROFIBUS GND (electrically isolated)
	6	+5 V / 50 mA	+5 V supply / 50 mA (electrically isolated)
	7	---	---
	8	DATA\	Data\
	9	CNTRL\	Transmit enable\

Table 113: X3 connector (PROFIBUS) - Pinout

#### 3.12.13.4 X4 connector (inputs/outputs)

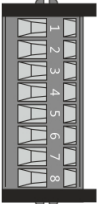
X4	Pin	Name	Function in incremental counter mode	Function in period/gate measurement mode	Function in stepper motor counter mode
	1	GND	GND		
	2	+24 VDC	Dig. supply I/O +24V <sup>1)</sup>		
	3	Digital I/O 1	A	Counter input	
	4	Digital I/O 2	B	---	Counting direction
	5	Digital I/O 3	R	External clock	---
	6	Shield	Shield		
	7	Analog I +	Analog Input +		
	8	Analog I -	Analog Input -		

Table 114: X4 connector (inputs/outputs) - Pinout

1) The +24 V supply is only necessary for digital I/O 1 .. 3.

### 3.12.13.5 Application interface IF5 (Ethernet)

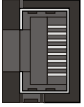
X6	Pin	Name	Function
	1	RXD	Receive signal
	2	RXD\	Receive signal inverted
	3	TXD	Transmit signal
	4	Termination	Termination
	5	Termination	Termination
	6	TXD\	Transmit signal inverted
	7	Termination	Termination
	8	Termination	Termination

Table 115: X6 connector (Ethernet) - Pinout

### 3.13 AC141 - CPU module

#### 3.13.1 General information

The AC141 plug-in module can be used in an ACOPOS slot (requires two slots).

The CPU module makes it possible to operate an ACOPOS servo drive without an external PLC and is also available with an integrated "Soft CNC" system (8AC141.61-3).

Communication in the ACOPOS network occurs as described in the section "Drive-based control" on page 22.

The ACOPOS servo drive in which the AC141 is plugged into is connected via emulation of an AC110 CAN interface plug-in module in slot 1. All other CAN stations are connected via the IF2 CAN interface.

This module offers interchangeable application memory in the form of a CompactFlash card as well as a separate backup battery for the module. <sup>3)</sup>

It is equipped with five application interfaces:

- One RS232 interface (IF1) for programming and configuring using B&R Automation Studio™
- Two CAN interfaces (IF2, IF3) for connecting to CAN networks
- One X2X Link interface (IF4)
- One Ethernet interface (IF6) for connecting to an Ethernet network.

In addition, a maximum of three digital inputs / outputs are provided as well as one analog input ( $\pm 10$  V differential input).

The digital inputs and outputs can be configured individually as an input or output. Additional functions such as a counter function with direction switching (stepper motor) or period and gate measurement are integrated.

The inputs and outputs are scanned directly by the CPU module; the ACOPOS servo drive does not have direct access to these inputs and outputs.

The analog input has a resolution of 12 bits and an analog input filter with 10 kHz (3rd-order low pass).

#### 3.13.2 Order data


Model number	Short description	Figure
8AC141.60-2	ACOPOS plug-in module, CPU, x86 100 MHz Intel compatible, 16 MB DRAM, 32 kB SRAM, removable application memory: CompactFlash, 2 CAN interfaces, 1 Ethernet interface 100 Base-T, 1 RS232 interface, 1 X2X Link Master interface, 3 digital I/O can be configured as 24 VDC input or output 500 mA, 1 analog input $\pm 10$ V, order program memory and 0TB704 and 0TB708 terminal blocks separately	
8AC141.61-3	ACOPOS plug-in module, CPU, ARNC0, x86 100 MHz Intel compatible, 32 MB DRAM, 32 kB SRAM, removable application memory: CompactFlash, 2 CAN interfaces, 1 Ethernet interface 100 Base-T, 1 RS232 interface, 1 X2X Link Master interface, 3 digital I/O can be configured as 24 VDC input or output 500 mA, 1 analog input $\pm 10$ V, order program memory and 0TB704 and 0TB708 terminal blocks separately	
<b>Required accessories</b>		
<b>CompactFlash</b>		
0CFCRD.0128E.01	Compact Flash 128MB WD extended Temp.	
0CFCRD.0512E.01	Compact Flash 512MB WD extended Temp.	
5CFCRD.0064-03	CompactFlash 64 MB Western Digital (SLC)	
5CFCRD.0128-03	CompactFlash 128 MB Western Digital (SLC)	
5CFCRD.0256-03	CompactFlash 256 MB Western Digital (SLC)	
5CFCRD.0512-03	CompactFlash 512 MB Western Digital (SLC)	
5CFCRD.1024-03	CompactFlash 1 GB Western Digital (SLC)	
5CFCRD.2048-03	CompactFlash 2 GB Western Digital (SLC)	
5CFCRD.4096-03	CompactFlash 4 GB Western Digital (SLC)	
5CFCRD.8192-03	CompactFlash 8 GB Western Digital (SLC)	
<b>Terminal blocks</b>		
0TB704.9	Accessory terminal block, 4-pin, screw clamp 2.5 mm <sup>2</sup>	
0TB704.91	Accessory terminal block, 4-pin, cage clamp 2.5 mm <sup>2</sup>	
0TB708.91	Accessory terminal block, 8-pin, cage clamp 1.5 mm <sup>2</sup>	
0TB708:91-02	Accessory terminal block, 8 pins, 20 pieces cage clamp 1,5 mm <sup>2</sup>	
<b>Optional accessories</b>		
<b>Batteries</b>		

Table 116: 8AC141.60-2, 8AC141.61-3 - Order data

<sup>3)</sup> Application memory must be ordered separately.

Model number	Short description	Figure
0AC201.91	Lithium batteries 4 pcs., 3 V / 950 mAh button cell. We hereby state that the lithium cells contained in this shipment qualify as "partly regulated". Handle with care. If the package is damaged, inspect the cells, repack intact cells and protect the cells against short circuit. For emergency information, call RENATA SA at +41 61 319 28 27.	
	<b>Cables</b>	
0G0001.00-090	PC - PLC/PW cable, RS232, online cable	
	<b>Infrastructure components</b>	
0AC912.9	Bus adapter, CAN, 1 CAN interface	
0AC913.92	Bus adapter, CAN, 2 CAN interfaces, including 30 cm attachment cable (DSUB)	
7AC911.9	Bus connector, CAN	

Table 116: 8AC141.60-2, 8AC141.61-3 - Order data

### 3.13.3 Technical data

Product ID	8AC141.60-2	8AC141.61-3
<b>General information</b>		
Module type	ACOPOS double-width plug-in module	
B&R ID code	0x1DDA	0x2275
Slot <sup>1)</sup>	Slots 1 + 2	
Power consumption	Max. 4.5 W	
ACOPOS capability	Yes	
Visual Components support	Yes	
Certification c-UL-us	Yes	
<b>Controller</b>		
Operating system	AC140 (version V2.80 and higher)	
DRAM	16 MB	32 MB
Processor clock	100 MHz	
SRAM	32 kB	
<b>Inputs/Outputs</b>		
Module-side connection	8-pin connector	
Configuration of digital inputs/outputs	Individually configurable as inputs or outputs	
<b>Incremental encoder</b>		
Counter size	16-bit	
Input frequency	Max. 20 kHz	
Evaluation	4x	
Signal form	Square wave pulse	
Encoder monitoring	No	
Counter frequency	Max. 80 kHz	
Reference frequency	Max. 20 kHz	
Distance between edges	Min. 5 µs	
Inputs Input 1 Input 2 Input 3	Channel A Channel B Reference pulse R	
<b>Digital inputs <sup>2)</sup></b>		
Quantity	Max. 3	
Modulation compared to ground potential	Max. ±30 V	
Wiring	Sink	
Input current at nominal voltage	Approx. 4.2 mA	
Input delay	<5 µs	
Switching threshold Low High	<5 V >15 V	
Input voltage Nominal Maximum	24 VDC 30 VDC	
Electrical isolation Channel - ACOPOS Channel - Channel	Yes No	
<b>Event counter</b>		
Signal form	Square wave pulse	
Input frequency	Max. 100 kHz	
Pulse length	Min. 5 µs	
Counter size	32-bit	
Inputs Input 1 Input 2	Counter 1 Count direction (only in stepper motor mode)	
<b>Gate measurement</b>		
Signal form	Square wave pulse	

Table 117: 8AC141.60-2, 8AC141.61-3 - Technical data

Product ID	8AC141.60-2	8AC141.61-3
Counter frequency	31.25 kHz or 4 MHz	
Internal	31.25 kHz or 4 MHz	
External	Max. 100 kHz	
Pulse length	Min. 5 µs	
Gate frequency	Max. 100 kHz	
<b>Period measurement</b>		
Signal form	Square wave pulse	
Input frequency	Max. 100 kHz	
Pulse length	Min. 5 µs	
Counter frequency	31.25 kHz or 4 MHz	
Internal	31.25 kHz or 4 MHz	
External	Max. 100 kHz	
<b>Analog inputs</b>		
Digital converter resolution	12-bit	
Conversion time	<50 µs	
Output format	INT 16 \$8001 - \$7FFF LSB = \$0010 = 4.88 mV	
Design	Differential input	
Electrical isolation	No, max. modulation: ±13 V	
Input - ACOPOS <sup>3)</sup>	No, max. modulation: ±13 V	
Input signal		
Nominal	-10 to +10 V	
Maximum	-13 to +13 V	
Operating modes	Cyclic measurement non-synchronous to 50 µs ACOPOS clock	
Conversion procedure	Successive approximation	
Input filter	Analog low pass 3rd-order Cut-off frequency: 10 kHz	
Common-mode rejection		
DC	Min. 73 dB	
50 Hz	Min. 73 dB	
Non-linearity	±2 LSB	
Differential input impedance	20 MΩ	
<b>Digital outputs</b>		
Quantity	Max. 3	
Readable outputs	Yes	
Continuous short circuit current at 24 V	Typ. 4 A	
Continuous current	Max. 500 mA	
Switching frequency (resistive load)	Max. 100 Hz	
Switching delay	Max. 500 µs (typ. 250 µs)	
Type	High-side transistor outputs	
Electrical isolation		
Output - ACOPOS	Yes	
Output - Output	No	
Switching voltage		
Minimum	18 VDC	
Nominal	24 VDC	
Maximum	30 VDC	
Protection		
Short circuit protection	Yes	
Overload protection	Yes	
<b>Interfaces</b>		
IF1 interface		
Type	RS232	
Design	9-pin DSUB connector	
Status indicators	232 LED	
Electrical isolation	No	
Max. baud rate	115.2 kbaud	
Max. distance	15 m / 19200 Baud	
IF2 interface		
Type	CAN bus	
Design	9-pin DSUB connector	
Status indicators	CAN1 LED	
Bus terminating resistor	Externally wired	
Electrical isolation	Yes	
Max. distance	1000 m	
Network-capable	Yes	
Max. transfer rate		
Bus length ≤60 m	500 kbit/s	
Bus length ≤200 m	250 kbit/s	
Bus length ≤1000 m	50 kbit/s	

Table 117: 8AC141.60-2, 8AC141.61-3 - Technical data

Product ID	8AC141.60-2	8AC141.61-3
IF3 interface		
Type		CAN bus
Design		9-pin DSUB connector
Status indicators		CAN2 LED
Bus terminating resistor		Externally wired
Electrical isolation		Yes
Max. distance		1000 m
Network-capable		Yes
Max. transfer rate		
Bus length ≤60 m		500 kbit/s
Bus length ≤200 m		250 kbit/s
Bus length ≤1000 m		50 kbit/s
IF4 interface		
Type		X2X
Design		4-pin connector
Status indicators		X2X LED
Electrical isolation		Yes
Max. distance		100 m
IF6 interface		
Type		Ethernet
Design		RJ45 connector
Status indicators		ACT LED
Baud rate		10/100 Mbit/s
Electrical isolation		Yes
Max. distance		100 m
Network-capable		Yes
<b>Environmental conditions</b>		
Temperature		
Operation		
Nominal		5 to 40°C
Maximum		55°C
Storage		-25 to 55°C
Transport		-25 to 70°C
Relative humidity		
Operation		5 to 85%
Storage		5 to 95%
Transport		Max. 95% at 40°C

Table 117: 8AC141.60-2, 8AC141.61-3 - Technical data

- 1) The AC141 is a double-width module that occupies slots 1 and 2.
- 2) Shielded cables must be used for inputs 1 - 3.
- 3) External electrical isolation of the connected sensors is recommended since the analog input is not electrically isolated.

### 3.13.4 Status indicators


Figure	LED	Name	Color	Description
	1	Status (RUN)	Red Red with orange blinking Red/green blinking (1 Hz) Orange Green Green with orange blinking	ERROR/RESET Load/unload and start BOOT AR Startup of BOOT or CF - AR SERVICE/DIAG/BOOT mode RUN RUN - BATTERY LOW
	2	RS232 (232)	Orange blinking	Data transfer to application interface IF1 (RS232)
	3	CAN2 (CAN2)	Orange	Data transfer on application interface IF3 (CAN2)
	4	Ethernet (ACT)	Orange Orange blinking	Ethernet LINK (IF6) Ethernet ACTIVE (IF6)
	5	CAN1 (CAN1)	Orange	Data transfer on application interface IF2 (CAN)
	6	X2X (X2X)	Orange	Data transfer on application interface IF4 (X2X)

Table 118: AC141 - Status indicators

### 3.13.5 Setting the CAN station number (IF2)

The CAN station number can be set using two HEX code switches:

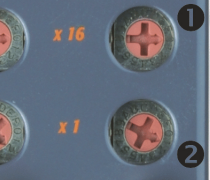
Figure	Switch	Description
	1	CAN station number 16s position (high)
	2	CAN station number 1s position (low)
The settings \$00, and \$FF are reserved for special functions.		
<b>\$00:</b> In this switch position, the operating system can be programmed via the online interface. User Flash is only deleted after the update begins.		
<b>\$FF:</b> Diagnostics mode.		

Table 119: Setting the CAN station number

A changed CAN station number will take effect the next time the ACOPOS servo drive is switched on.

There must be a terminating resistor (120 Ω, 0.25 W) between CAN\_H and CAN\_L at the beginning and end of the CAN bus.

#### Information:

The CAN bus IF2 is always made up of at least two stations that are integrated in the AC141. These are the AC141 CPU and an AC110 emulation, which the ACOPOS uses for communication. Therefore, the AC141 CPU prevents a potential error in which no other stations are found on the CAN bus. This is why the AC141 CPU does not register a hardware error if there is no physical connection to external CAN devices.

### 3.13.6 Setting the CAN station number (IF3)

The CAN station number can be set using two HEX code switches:

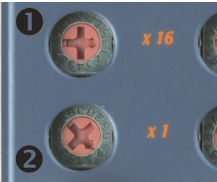
Figure	Switch	Description
	1	CAN station number 16s position (high)
	2	CAN station number 1s position (low)
The settings \$00, and \$FF are reserved for special functions.		
<b>\$00:</b> In this switch position, the operating system can be programmed via the online interface. User Flash is only deleted after the update begins.		
<b>\$FF:</b> Diagnostics mode.		

Table 120: Setting the CAN station number (IF3)

A changed CAN station number will take effect the next time the ACOPOS servo drive is switched on.

There must be a terminating resistor (120 Ω, 0.25 W) between CAN\_H and CAN\_L at the beginning and end of the CAN bus.

### 3.13.7 Setting the Ethernet station number (IF6)

The Ethernet station number can be set using software (B&R Automation Studio™).

### 3.13.8 Reset button

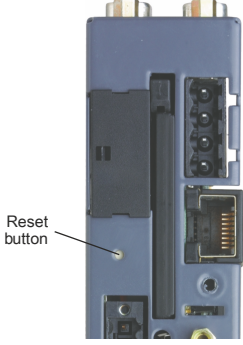
View (view from below)	Description
 <p>Reset button</p> <p>View from below</p>	<p>The reset button can be pressed with any small pointed object (e.g. paper clip). Pressing the reset button triggers a hardware reset, which means:</p> <ul style="list-style-type: none"> <li>• All application programs are stopped.</li> <li>• All outputs are set to zero.</li> </ul> <p>The AC141 then switches to SERVICE mode.</p>

Table 121: Reset button

### 3.13.9 Slot for application memory (CompactFlash)

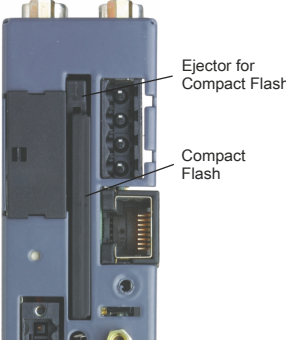
Figure	Description
 <p>Ejector for Compact Flash</p> <p>Compact Flash</p> <p>View from below</p>	<p>Program memory is required to operate the AC141. The application memory is CompactFlash. This is not included with the delivery of the AC141. CompactFlash must be ordered separately as an accessory!</p> <p>The CompactFlash memory card is used in the slot on the bottom of the AC141. Press the eject button to remove the card.</p> <p>The CompactFlash memory card can be secured with the safety clip.</p>

Table 122: Application memory

### 3.13.10 Backup battery

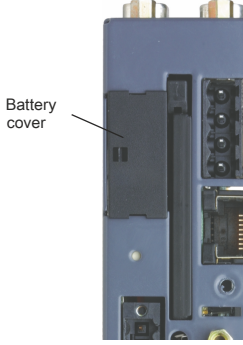
Image	Description															
 <p>Battery cover</p> <p>View from below</p>	<p>The AC141 is equipped with a lithium battery. The lithium battery is placed in a separate compartment on the bottom of the module and protected by a cover.</p> <table border="1" data-bbox="464 1346 1466 1532"> <thead> <tr> <th colspan="2" data-bbox="464 1346 1466 1373">Backup battery data</th> </tr> </thead> <tbody> <tr> <td data-bbox="464 1377 730 1404">Lithium battery</td> <td data-bbox="734 1377 1466 1404">3V / 950 mAh</td> </tr> <tr> <td data-bbox="464 1408 730 1435">Model number</td> <td data-bbox="734 1408 1466 1435">0AC201.91</td> </tr> <tr> <td data-bbox="464 1440 730 1467">Short description</td> <td data-bbox="734 1440 1466 1467">Lithium batteries, 4 pcs., 3 V / 950 mAh, button cell</td> </tr> <tr> <td data-bbox="464 1471 730 1498">Storage temperature</td> <td data-bbox="734 1471 1466 1498">-20 to +60°C</td> </tr> <tr> <td data-bbox="464 1503 730 1529">Storage time</td> <td data-bbox="734 1503 1466 1529">Max. 3 years at 30°C</td> </tr> <tr> <td data-bbox="464 1534 730 1561">Relative humidity</td> <td data-bbox="734 1534 1466 1561">0 to 95%, non-condensing</td> </tr> </tbody> </table>		Backup battery data		Lithium battery	3V / 950 mAh	Model number	0AC201.91	Short description	Lithium batteries, 4 pcs., 3 V / 950 mAh, button cell	Storage temperature	-20 to +60°C	Storage time	Max. 3 years at 30°C	Relative humidity	0 to 95%, non-condensing
Backup battery data																
Lithium battery	3V / 950 mAh															
Model number	0AC201.91															
Short description	Lithium batteries, 4 pcs., 3 V / 950 mAh, button cell															
Storage temperature	-20 to +60°C															
Storage time	Max. 3 years at 30°C															
Relative humidity	0 to 95%, non-condensing															

Table 123: Backup battery

## Data / real-time buffering

The following areas are buffered:

- Remanent variables
- User RAM
- System RAM
- Real-time clock

## Battery monitoring

The battery voltage is checked cyclically. The cyclic load test of the battery does not considerably shorten the battery life, instead it gives an early warning of weakened buffer capacity.

The status information "Battery OK" is available from the "BatteryInfo" system library function.

## Battery change interval

### **Caution!**

The battery should be changed every 4 years. The change intervals refer to the average service life and operating conditions and are recommended by B&R. It is not the maximum buffer duration.

### **Information:**

Data stored in the AC141 RAM will be lost if the battery is changed with the PLC switched off! The battery can be changed with power applied, but this is not allowed in all countries!

### **Warning!**

The battery must be replaced by a Type CR2477N Renata battery only. The use of another battery may present a risk of fire or explosion.

The battery may explode if handled improperly. Do not recharge, disassemble or dispose of in fire.

### Procedure for changing the battery

1. Touch the mounting rail or ground connection (not the power supply!) in order to discharge any electrostatic charge from your body.
2. Remove the cover from the lithium battery holder using a screwdriver.

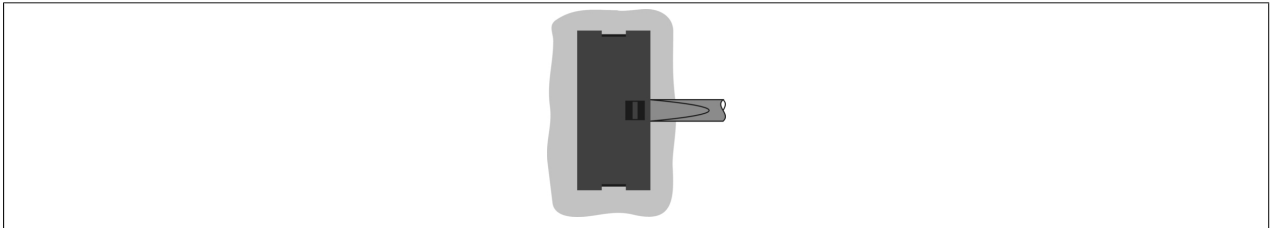


Figure 44: Remove the cover for the lithium battery

3. Remove the battery from the holder by pulling the removal strip (don't use uninsulated tools because of risk of short circuiting). The battery should not be held by its edges. Insulated tweezers may also be used for removing the battery.

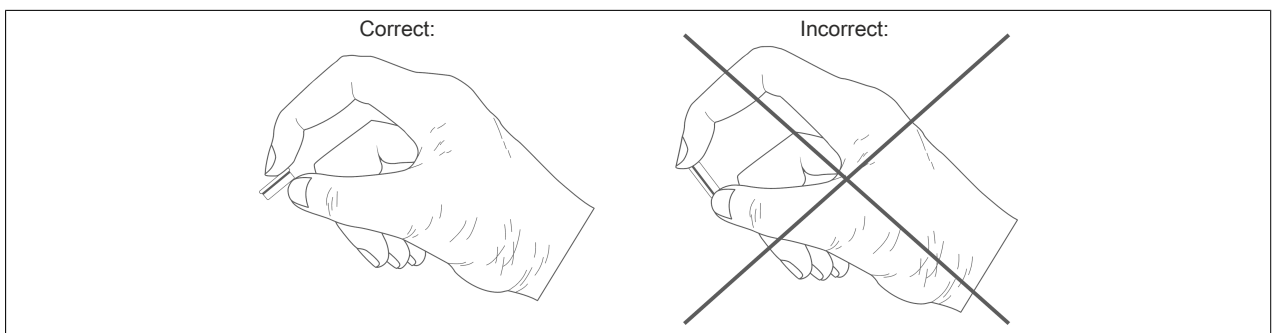


Figure 45: Hold the battery correctly

4. Insert the new battery with correct polarity. The removal strip should be pulled to the right of the battery holder and the "+" side of the battery should be facing left. In order to be able to remove the battery again in future, the removal strip **must be on the right side** of the battery.

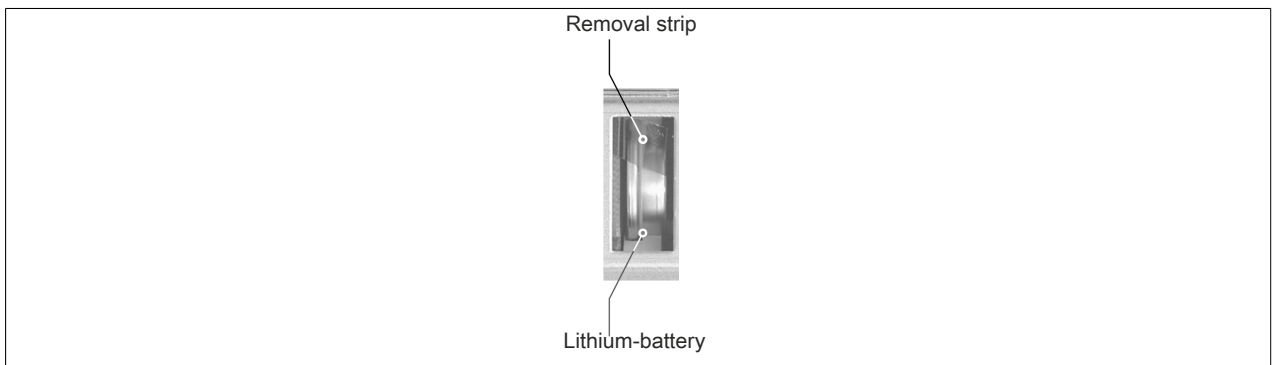


Figure 46: Removal strip should be pulled to the right

5. Now wrap the end of the removal strip over the top of the battery and insert it underneath the battery so that it does not protrude from the battery holder.
6. Replace cover. Insert the lower edge of the cover in the battery holder opening. Press the upper end of the cover home firmly.

### Information:

**Lithium batteries are considered hazardous waste. Used batteries should be disposed of appropriately.**

### 3.13.11 Input/Output registers

#### Digital in r/- (16-bit):

Bit no.	Value	Description
0		Logical status of digital I/O 1
1		Logical status of digital I/O 2
2		Logical status of digital I/O 3
3 - 15		Reserved

#### Digital out r/w (16-bit):

All reserved bits must be written with 0.

Bit no.	Value	Description
0	0	Digital output 1 inactive
	1	Digital output 1 active
1	0	Digital output 2 inactive
	1	Digital output 2 active
2	0	Digital output 3 inactive
	1	Digital output 3 active
3 - 15		Reserved

#### Analog in (16-bit) r/-:

±10V (12 bit resolution)

#### Counter (32-bit) r(w):

In addition to the typical counter modes, this counter has a "Stepper motor counter mode" (see Configuration register bits 4-6).

In stepper motor counter mode, the count direction is set using digital I/O 2 (0...increment, 1...decrement), and the counter clock is on digital I/O 1. Only one clock edge is used for counting (can be configured with bit 3 of the counter configuration register).

#### Counter configuration (16 bit) r/w:

All reserved bits must be written with 0.

Bit no.	Value	Description
0		Reserved
1	0	AB(R) counter mode: R input disabled
	1	AB(R) counter mode: R input enabled
2		Reserved
3	0	Measurement starts at increasing edge
	1	Measurement starts at falling edge
4 - 6	000	No counter operation
	001	AB(R) counter mode
	010	Event counter mode
	011	Period measurement mode
	100	stepper motor counter mode
	101	Gate measurement mode
	110	Not allowed
	111	Not allowed
7 - 8	00	Counter frequency 4MHz
	01	External counter frequency
	10	Counter frequency 31.25kHz
	11	Not allowed
9	0	Counter overflow recognition disabled / Reset counter overflow bit
	1	Overflow recognition of the continuous counter is enabled (value limited to \$FFFF)
10 - 14		Reserved
15	0	Time / counter reset
	1	Time / counter enabled (ATTENTION: Only set bit after counter configuration is complete)

#### Status (16 Bit) r/- :

Bit no.	Value	Description
0 - 8		Reserved
9	0	Period or gate measurement within the counter range 0 - \$FFFF (only valid if bit 9 is set in the counter configuration word)
	1	Counter overflow during period or gate measurement. Acknowledge by resetting bit 9 of the counter configuration word
10 - 14		Reserved
15	0	Output supply voltage monitoring 24 VDC - OK
	1	Output supply voltage monitoring 24 VDC error

### 3.13.12 Wiring

#### 3.13.12.1 Application interface IF1 (RS232)

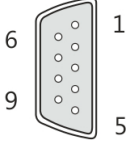
X1	Pin	Name	Function
	1	DCD	Data Carrier Detect
	2	RXD	Receive signal
	3	TXD	Transmit signal
	4	DTR	Data Terminal Ready
	5	GND	Ground
	6	DSR	Data Set Ready
	7	RTS	Request To Send
	8	CTS	Clear To Send
	9	RIN	Ring indicator

Table 124: X1 connector (RS232) - Pinout

#### 3.13.12.2 Application interface IF2 (CAN1)

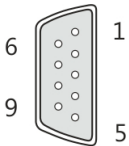
X2	Pin	Name	Function
	1	---	---
	2	CAN_L	CAN low
	3	CAN_GND	CAN 0 V
	4	---	---
	5	---	---
	6	---	---
	7	CAN_H	CAN high
	8	---	---
	9	---	---

Table 125: X2 connector (CAN1) - Pinout

#### 3.13.12.3 Application interface IF3 (CAN2)

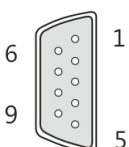
X3	Pin	Name	Function
	1	---	---
	2	CAN_L	CAN low
	3	CAN_GND	CAN 0 V
	4	---	---
	5	---	---
	6	---	---
	7	CAN_H	CAN high
	8	---	---
	9	---	---

Table 126: X3 connector (CAN2) - Pinout

#### 3.13.12.4 X4 connector (inputs/outputs)

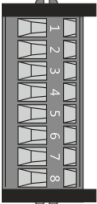
X4	Pin	Name	Function in incremental counter mode	Function in period/gate measurement mode	Function in stepper motor counter mode
	1	GND	GND		
	2	+24 VDC	Dig. supply I/O +24V <sup>1)</sup>		
	3	Digital I/O 1	A	Counter input	
	4	Digital I/O 2	B	---	Counting direction
	5	Digital I/O 3	R	External clock	---
	6	Shield	Shield		
	7	Analog I +	Analog Input +		
	8	Analog I -	Analog Input -		

Table 127: X4 connector (inputs/outputs) - Pinout

1) The +24 V supply is only necessary for digital I/O 1 .. 3.

### 3.13.12.5 Application interface IF4 (X2X)


X5		Pin	Name	Function
	1	1	X2X	X2X data
	2	2	X2X <sub>L</sub>	X2X ground
	3	3	X2X <sub>I</sub>	X2X data inverted
	4	4	SHLD	Shield

Table 128: X5 connector (X2X) - Pinout

### 3.13.12.6 Application interface IF6 (Ethernet)

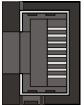
X6		Pin	Name	Function
	1	1	RXD	Receive signal
	2	2	RXD <sub>I</sub>	Receive signal inverted
	3	3	TXD	Transmit signal
	4	4	Termination	Termination
	5	5	Termination	Termination
	6	6	TXD <sub>I</sub>	Transmit signal inverted
	7	7	Termination	Termination
	8	8	Termination	Termination

Table 129: X6 connector (Ethernet) - Pinout

## 4 8B0W external braking resistors

8B0W external braking resistors are used to dissipate braking energy on ACOPOS servo drives.

### 4.1 Order data


Model number	Short description	Figure
	<b>Braking resistors</b>	
8B0W0045H000.000-1	ACOPOS multi braking resistor, 450 W, 50 R, IP20, terminals	
8B0W0045H000.001-1	ACOPOS multi braking resistor, 450 W, 50 R, IP65, terminals	
8B0W0079H000.000-1	ACOPOS multi braking resistor, 790 W, 33 R, IP20, terminals	
8B0W0079H000.001-1	ACOPOS multi braking resistor, 790 W, 33 R, IP65, terminals	

Table 130: 8B0W0045H000.000-1, 8B0W0045H000.001-1, 8B0W0079H000.000-1, 8B0W0079H000.001-1 - Order data

### 4.2 Technical data

Product ID	8B0W0045H000.000-1	8B0W0045H000.001-1	8B0W0079H000.000-1	8B0W0079H000.001-1
<b>General information</b>				
RoHS-compliant	Yes			
Cooling and mounting method	Wall mounting			
Certification cULus	Yes			
<b>Braking resistors</b>				
Continuous power depending on the mounting orientation				
Standing horizontally	360 W		632 W	
Hanging vertically	450 W		790 W	
Reduction of continuous power depending on ambient temperature	7.5 W/K (from 40°C)		13.2 W/K (from 40°C)	
Ohmic resistance	50 Ω ±10%		33 Ω ±10%	
Max. operating voltage	850 VDC			
Isolation voltage type test	4000 VAC			
Intrinsically safe	Yes <sup>1)</sup>			
Design	Terminals with tension spring technology			
RB1, RB2				
PE	M5 threaded bolt	M4 threaded bolt	M5 threaded bolt	M4 threaded bolt
Shield connection	Yes, on the terminal box via high-strength cable gland			
Terminal connection cross section				
Flexible and fine wire lines				
With wire end sleeves	1.5 to 10 mm <sup>2</sup>			
Approbation data				
UL/C-UL-US	24 to 6			
CSA	22 to 6			
Terminal cable outer-cross-section dimension of the connection cable	9 to 16.6 mm			
<b>Temperature model data</b>				
Thermal resistance between braking resistor and the environment	1.517 K/W		0.852 K/W	
Heat capacitance of the filament	16.3 J/K		22.6 J/K	
Max. permissible overtemperature	680°C		670°C	
<b>Operating conditions</b>				
Permitted mounting orientations				
Standing horizontally	Yes			
Hanging vertically				
Connection box, bottom	Yes			
Connection box, top	No			
Protection in accordance with EN 60529				
Standing horizontally	IP20	IP65	IP20	IP65
Hanging vertically				
Connection box, bottom	IP21	-	IP21	-
Connection box, top				
<b>Environmental conditions</b>				
Temperature				
Operation	-40 to 90°C			
Relative humidity				
Operation	5 to 95%			

Table 131: 8B0W0045H000.000-1, 8B0W0045H000.001-1, 8B0W0079H000.000-1, 8B0W0079H000.001-1 - Technical data

Product ID	8B0W0045H000.000-1	8B0W0045H000.001-1	8B0W0079H000.000-1	8B0W0079H000.001-1
<b>Mechanical characteristics</b>				
Dimensions				
Width	124 mm			
Height	121 mm			
Depth	403 mm	332 mm	603 mm	532 mm
Weight	2.4 kg		3.9 kg	

Table 131: 8B0W0045H000.000-1, 8B0W0045H000.001-1, 8B0W0079H000.000-1, 8B0W0079H000.001-1 - Technical data

- 1) 8B0W external braking resistors can be considered intrinsically safe if they are connected to a 8B0P passive power supply module operated with a mains supply voltage of 3x 380 - 500 VAC. The maximum time until the 8B0W external braking resistors are destroyed is approximately 5.5 min in this case; a maximum surface temperature of approximately 480°C is achieved when this happens.  
A lower mains supply voltage on the 8B0P passive power supply module allows a longer maximum time before the 8B0W external braking resistor is damaged, which also results in higher temperatures.

### 4.3 Wiring

#### 4.3.1 8B0W braking resistors - Pinout

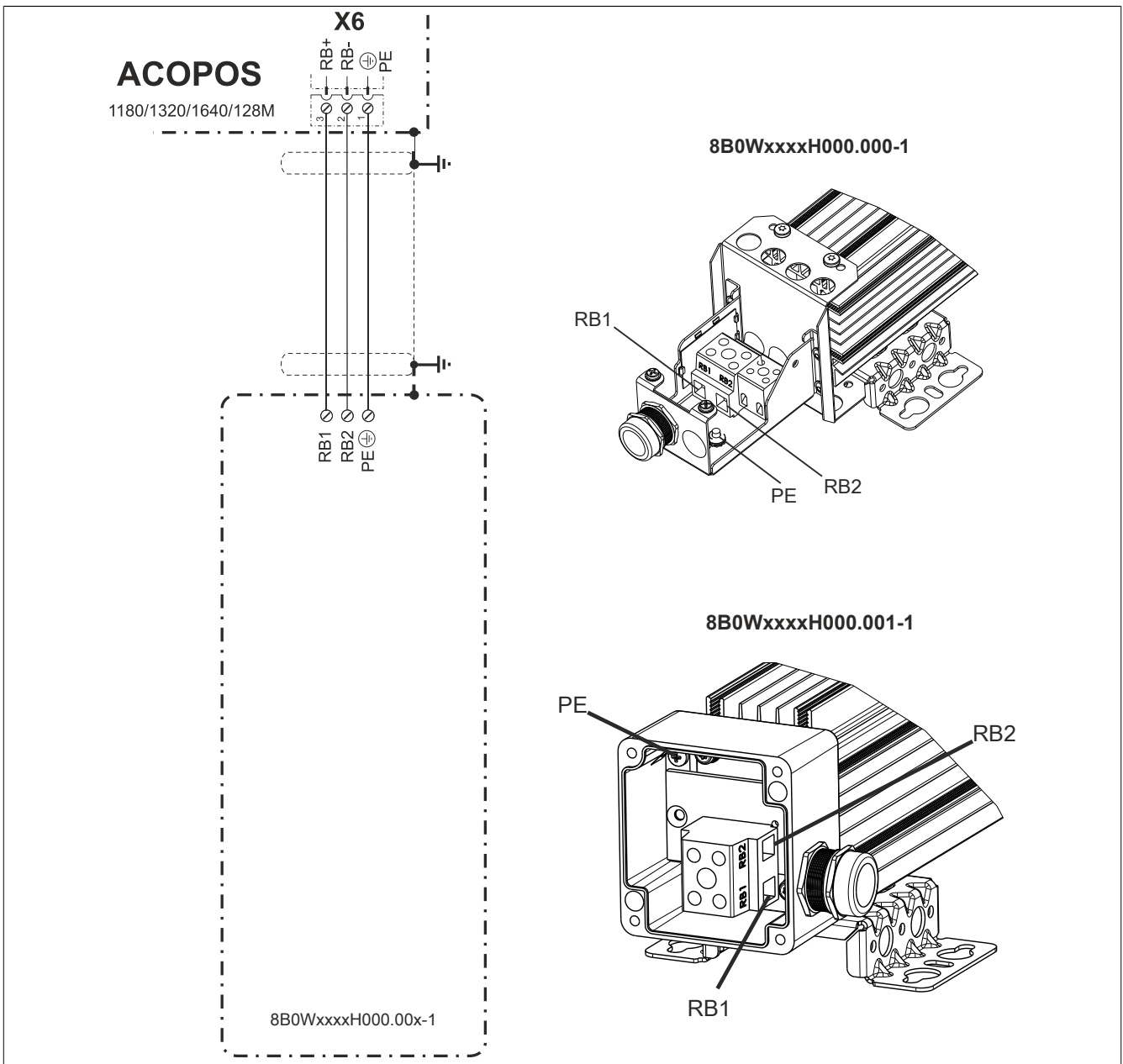


Figure 47: 8B0W - Pinout overview

**Information:**

**8B0W external braking resistors must be wired using connection cables that are suited for maximum line temperatures >90°C.**

**Shielded cables must be used for wiring!**

## 5 Cables

### 5.1 General information

B&R offers the cables for ACOPOS servo drives in six different lengths. All cables can be used for drag chain installations. <sup>4)</sup>

To prevent disturbances to encoder signals, the holding brake and temperature sensor wires are in the motor cable and not in the encoder cable.

#### 5.1.1 Assembled cables

Using B&R cables guarantees that the EMC limits are not exceeded. The cables are assembled in the EU and are therefore subject to the strictest quality standards.

#### Information:

**If cables from other manufacturers are used, make sure that they have the same wave parameters and the same design as the respective B&R cable. If deviations exist, additional measures are necessary to ensure that EMC directives are met. When using cables from other manufacturers, B&R cannot guarantee adherence to EMC limit values! The connectors on the cables and also on the motors are part of a properly functioning EMC concept!**

### 5.2 Motor cables

#### 5.2.1 0.75 mm<sup>2</sup> motor cables

##### 5.2.1.1 Order data

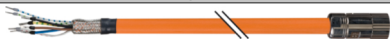
Model number	Short description	Figure
	<b>0.75 mm<sup>2</sup> motor cables</b>	
8CM005.12-0	Motor cable, length 5 m, 4x 0.75 mm <sup>2</sup> + 2x 2x 0.35 mm <sup>2</sup> , 8-pin Intercontec motor connector, can be used in drag chains, UL/CSA listed	
8CM007.12-0	Motor cable, length 7 m, 4x 0.75 mm <sup>2</sup> + 2x 2x 0.35 mm <sup>2</sup> , 8-pin Intercontec motor connector, can be used in drag chains, UL/CSA listed	
8CM010.12-0	Motor cable, length 10 m, 4x 0.75 mm <sup>2</sup> + 2x 2x 0.35 mm <sup>2</sup> , 8-pin Intercontec motor connector, can be used in drag chains, UL/CSA listed	
8CM015.12-0	Motor cable, length 15 m, 4x 0.75 mm <sup>2</sup> + 2x 2x 0.35 mm <sup>2</sup> , 8-pin Intercontec motor connector, can be used in drag chains, UL/CSA listed	
8CM020.12-0	Motor cable, length 20 m, 4x 0.75 mm <sup>2</sup> + 2x 2x 0.35 mm <sup>2</sup> , 8-pin Intercontec motor connector, can be used in drag chains, UL/CSA listed	
8CM025.12-0	Motor cable, length 25 m, 4x 0.75 mm <sup>2</sup> + 2x 2x 0.35 mm <sup>2</sup> , 8-pin Intercontec motor connector, can be used in drag chains, UL/CSA listed	

Table 132: 8CM005.12-0, 8CM007.12-0, 8CM010.12-0, 8CM015.12-0, 8CM020.12-0, 8CM025.12-0 - Order data

#### Information:

**Other cable lengths and raw cables are available from B&R upon request.**

##### 5.2.1.2 Technical data

Product ID	8CM005.12-0	8CM007.12-0	8CM010.12-0	8CM015.12-0	8CM020.12-0	8CM025.12-0
<b>General information</b>						
Cable cross section	4x 0.75 mm <sup>2</sup> + 2x 2x 0.35 mm <sup>2</sup>					
Durability	Oil resistance according to VDE 0472 part 803 as well as standard hydraulic oil					
Listed	UL AWM Style 20234, 80°C, 1000 V, E63216 and CSA AWM I/II A/B, 90°C, 1000 V, FT2 LL46064					
Certification c-UL-us	Yes					

Table 133: 8CM005.12-0, 8CM007.12-0, 8CM010.12-0, 8CM015.12-0, 8CM020.12-0, 8CM025.12-0 - Technical data

<sup>4)</sup> Custom assembly of motor cables is available on request. For custom assembly of motor cables, the connector size must be matched to the motor used!

Product ID	8CM005.12-0	8CM007.12-0	8CM010.12-0	8CM015.12-0	8CM020.12-0	8CM025.12-0
<b>Cable structure</b>						
Power lines						
Quantity	4					
Wire insulation	Special thermoplastic material					
Wire colors	Black, brown, blue, yellow/green					
Design	Tinned copper litz wire					
Diameter	0.75 mm <sup>2</sup>					
Shielding	No					
Stranding	No					
Signal lines						
Quantity	4					
Wire insulation	Special thermoplastic material					
Wire colors	White, white/red, white/blue, white/green					
Design	Tinned copper litz wire					
Diameter	0.35 mm <sup>2</sup>					
Shielding	Separate shielding for pairs, tinned copper mesh, optical coverage >85% and foil banding					
Stranding	White with white/red and white/blue with white/green					
Cable stranding	With filler elements and foil banding					
Cable shielding	Tinned copper mesh, optical coverage >85% and wrapped in isolating film					
Outer sheathing						
Material	PUR					
Color	Orange, similar to RAL 2003 flat					
Labeling	BERNECKER + RAINER 4x0,75+2x2x0,35 FLEX UL AWM STYLE 20234 80°C 1000 V E63216 CSA AWM I/II A/B 90°C 1000 V FT2 LL46064					
<b>Electrical characteristics</b>						
Test voltage						
Wire/Wire	3 kV					
Wire/Shield	3 kV					
Conductor resistance						
Power lines	≤0.15 Ω	≤0.20 Ω	≤0.29 Ω	≤0.44 Ω	≤0.58 Ω	≤0.73 Ω
Signal lines	≤0.28 Ω	≤0.39 Ω	≤0.55 Ω	≤0.83 Ω	≤1.1 Ω	≤1.38 Ω
Insulation resistance	>40 GΩ	>28.57 GΩ	>20 GΩ	>13.33 GΩ	>10 GΩ	>8 GΩ
Max. current load in accordance with IEC 60364-5-523 by installation type						
Wall mounting	13 A					
Installed in conduit or cable duct	11.5 A					
Installed in cable tray	13.5 A					
<b>Environmental conditions</b>						
Temperature						
Moving	-10 to 80°C					
Static	-40 to 90°C					
<b>Mechanical characteristics</b>						
Dimensions						
Length	5 m	7 m	10 m	15 m	20 m	25 m
Diameter	10.9 mm ±0.4 mm					
Flex radius						
Single bend	>34 mm					
Moving	≥85 mm					
Drag chain data						
Acceleration	<60 m/s <sup>2</sup>					
Flex cycles <sup>1)</sup>	≥3,000,000					
Velocity	≤4 m/s					
Weight	0.98 kg	1.32 kg	1.82 kg	2.67 kg	3.52 kg	4.37 kg

Table 133: 8CM005.12-0, 8CM007.12-0, 8CM010.12-0, 8CM015.12-0, 8CM020.12-0, 8CM025.12-0 - Technical data

1) At an ambient temperature of 20°C and a flex radius of 125 mm.

## 5.2.2 1.5 mm<sup>2</sup> motor cables

### 5.2.2.1 Order data


Model number	Short description	Figure
	<b>1.5 mm<sup>2</sup> motor cables</b>	
8CM005.12-1	Motor cable, length 5 m, 4x 1.5 mm <sup>2</sup> + 2x 2x 0.75 mm <sup>2</sup> , 8-pin Intercontec motor connector, can be used in drag chains, UL/CSA listed	
8CM007.12-1	Motor cable, length 7 m, 4x 1.5 mm <sup>2</sup> + 2x 2x 0.75 mm <sup>2</sup> , motor plug 8-pin Intercontec socket, can be used in cable drag chains, UL/CSA listed	
8CM010.12-1	Motor cable, length 10 m, 4x 1.5 mm <sup>2</sup> + 2x 2x 0.75 mm <sup>2</sup> , 8-pin Intercontec motor connector, can be used in drag chains, UL/CSA listed	
8CM015.12-1	Motor cable, length 15 m, 4x 1.5 mm <sup>2</sup> + 2x 2x 0.75 mm <sup>2</sup> , 8-pin Intercontec motor connector, can be used in drag chains, UL/CSA listed	
8CM020.12-1	Motor cable, length 20 m, 4x 1.5 mm <sup>2</sup> + 2x 2x 0.75 mm <sup>2</sup> , 8-pin Intercontec motor connector, can be used in drag chains, UL/CSA listed	
8CM025.12-1	Motor cable, length 25 m, 4x 1.5 mm <sup>2</sup> + 2x 2x 0.75 mm <sup>2</sup> , 8-pin Intercontec motor connector, can be used in drag chains, UL/CSA listed	

Table 134: 8CM005.12-1, 8CM007.12-1, 8CM010.12-1, 8CM015.12-1, 8CM020.12-1, 8CM025.12-1 - Order data

### Information:

Other cable lengths and raw cables are available from B&R upon request.

### 5.2.2.2 Technical data

Product ID	8CM005.12-1	8CM007.12-1	8CM010.12-1	8CM015.12-1	8CM020.12-1	8CM025.12-1
<b>General information</b>						
Cable cross section	4x 1.5 mm <sup>2</sup> + 2x 2x 0.75 mm <sup>2</sup>					
Durability	Oil resistance according to VDE 0472 part 803 as well as standard hydraulic oil					
Listed	UL AWM Style 20234, 80 °C, 1000 V, E63216 and CSA AWM I/II A/B, 90 °C, 1000 V, FT2 LL46064	UL AWM Style 20234, 80 °C, 1000 V, E63216 and CSA AWM I/III A/B, 90 °C, 1000 V, FT2 LL46064	UL AWM Style 20234, 80 °C, 1000 V, E63216 and CSA AWM I/II A/B, 90 °C, 1000 V, FT2 LL46064			
Certification c-UL-us	Yes					
<b>Cable structure</b>						
Power lines	4 Special thermoplastic material Black, brown, blue, yellow/green Tinned copper litz wire					
Quantity	4					
Wire insulation	Special thermoplastic material					
Wire colors	Black, brown, blue, yellow/green					
Design	Tinned copper litz wire	Tinned Cu wire	Tinned copper litz wire			
Diameter	1.5 mm <sup>2</sup>					
Shielding	No					
Stranding	No					
Signal lines	4 Special thermoplastic material White, white/red, white/blue, white/green Tinned copper litz wire					
Quantity	4					
Wire insulation	Special thermoplastic material					
Wire colors	White, white/red, white/blue, white/green					
Design	Tinned copper litz wire	Tinned Cu wire	Tinned copper litz wire			
Diameter	0.75 mm <sup>2</sup>					
Shielding	Separate shielding for pairs, tinned copper mesh, optical coverage >85% and foil banding	Separate shielding for pairs, tinned Cu mesh, optical coverage 85% and foil banding	Separate shielding for pairs, tinned copper mesh, optical coverage >85% and foil banding			
Stranding	White with white/red and white/blue with white/green					
Cable stranding	With filler elements and foil banding					
Cable shielding	Tinned copper mesh, optical coverage >85% and wrapped in isolating film	Tinned Cu mesh, optical coverage >85% and wrapped in isolating film	Tinned copper mesh, optical coverage >85% and wrapped in isolating film			

Table 135: 8CM005.12-1, 8CM007.12-1, 8CM010.12-1, 8CM015.12-1, 8CM020.12-1, 8CM025.12-1 - Technical data

Product ID	8CM005.12-1	8CM007.12-1	8CM010.12-1	8CM015.12-1	8CM020.12-1	8CM025.12-1														
Outer sheathing	PUR Orange, similar to RAL 2003 flat BERNECKER & RAINER 4x1.5+2x2x0.75 FLEX																			
Material																				
Color																				
Labeling																				
<b>Electrical characteristics</b>																				
Operating voltage	Max. 1000 V																			
Test voltage	1500 VAC																			
Wire/Wire																				
Wire/Shield	1500 VAC																			
Conductor resistance	<table border="1"> <tr> <td>Power lines</td> <td>≤0.07 Ω</td> <td>≤0.1 Ω</td> <td>≤0.14 Ω</td> <td>≤0.21 Ω</td> <td>≤0.28 Ω</td> <td>≤0.35 Ω</td> </tr> <tr> <td>Signal lines</td> <td>≤0.09 Ω</td> <td>≤0.13 Ω</td> <td>≤0.19 Ω</td> <td>≤0.29 Ω</td> <td>≤0.38 Ω</td> <td>≤0.48 Ω</td> </tr> </table>						Power lines	≤0.07 Ω	≤0.1 Ω	≤0.14 Ω	≤0.21 Ω	≤0.28 Ω	≤0.35 Ω	Signal lines	≤0.09 Ω	≤0.13 Ω	≤0.19 Ω	≤0.29 Ω	≤0.38 Ω	≤0.48 Ω
Power lines							≤0.07 Ω	≤0.1 Ω	≤0.14 Ω	≤0.21 Ω	≤0.28 Ω	≤0.35 Ω								
Signal lines	≤0.09 Ω	≤0.13 Ω	≤0.19 Ω	≤0.29 Ω	≤0.38 Ω	≤0.48 Ω														
Insulation resistance	>40 GΩ	>28.57 GΩ	>20 GΩ	>13.33 GΩ	>10 GΩ	>8 GΩ														
Max. current load in accordance with IEC 60364-5-523 by installation type	<table border="1"> <tr> <td>Wall mounting</td> <td>20 A</td> </tr> <tr> <td>Installed in conduit or cable duct</td> <td>17.8 A</td> </tr> <tr> <td>Installed in cable tray</td> <td>20.9 A</td> </tr> </table>						Wall mounting	20 A	Installed in conduit or cable duct	17.8 A	Installed in cable tray	20.9 A								
Wall mounting							20 A													
Installed in conduit or cable duct							17.8 A													
Installed in cable tray	20.9 A																			
Wall mounting																				
Installed in conduit or cable duct																				
Installed in cable tray																				
<b>Environmental conditions</b>																				
Temperature	<table border="1"> <tr> <td>Moving</td> <td>-10 to 70°C</td> </tr> <tr> <td>Static</td> <td>-20 to 90°C</td> </tr> </table>						Moving	-10 to 70°C	Static	-20 to 90°C										
Moving							-10 to 70°C													
Static	-20 to 90°C																			
Moving																				
Static																				
<b>Mechanical characteristics</b>																				
Dimensions	<table border="1"> <tr> <td>Length</td> <td>5 m</td> <td>7 m</td> <td>10 m</td> <td>15 m</td> <td>20 m</td> <td>25 m</td> </tr> <tr> <td>Diameter</td> <td colspan="6">12.8 mm ±0.4 mm</td> </tr> </table>						Length	5 m	7 m	10 m	15 m	20 m	25 m	Diameter	12.8 mm ±0.4 mm					
Length							5 m	7 m	10 m	15 m	20 m	25 m								
Diameter	12.8 mm ±0.4 mm																			
Length																				
Diameter																				
Flex radius	<table border="1"> <tr> <td>Single bend</td> <td>&gt;40 mm</td> </tr> <tr> <td>Moving</td> <td>≥99 mm</td> </tr> </table>						Single bend	>40 mm	Moving	≥99 mm										
Single bend							>40 mm													
Moving	≥99 mm																			
Single bend																				
Moving																				
Drag chain data	<table border="1"> <tr> <td>Acceleration</td> <td>&lt;60 m/s<sup>2</sup></td> </tr> <tr> <td>Flex cycles</td> <td>≥3,000,000</td> </tr> <tr> <td>Velocity</td> <td>≤4 m/s</td> </tr> </table>						Acceleration	<60 m/s <sup>2</sup>	Flex cycles	≥3,000,000	Velocity	≤4 m/s								
Acceleration							<60 m/s <sup>2</sup>													
Flex cycles							≥3,000,000													
Velocity	≤4 m/s																			
Acceleration																				
Flex cycles																				
Velocity																				
Weight	1.43 kg	2 kg	2.75 kg	3.98 kg	5.3 kg	6.6 kg														

Table 135: 8CM005.12-1, 8CM007.12-1, 8CM010.12-1, 8CM015.12-1, 8CM020.12-1, 8CM025.12-1 - Technical data

## 5.2.3 4 mm<sup>2</sup> motor cables

### 5.2.3.1 Order data


Model number	Short description	Figure
	<b>4 mm<sup>2</sup> motor cables</b>	
8CM005.12-3	Motor cable, length 5 m, 4x 4 mm <sup>2</sup> + 2x 2x 1 mm <sup>2</sup> , 8-pin Intercontec motor connector, can be used in drag chains, UL/CSA listed	
8CM007.12-3	Motor cable, length 7 m, 4x 4 mm <sup>2</sup> + 2x 2x 1 mm <sup>2</sup> , 8-pin Intercontec motor connector, can be used in drag chains, UL/CSA listed	
8CM010.12-3	Motor cable, length 10 m, 4x 4 mm <sup>2</sup> + 2x 2x 1 mm <sup>2</sup> , 8-pin Intercontec motor connector, can be used in drag chains, UL/CSA listed	
8CM015.12-3	Motor cable, length 15 m, 4x 4 mm <sup>2</sup> + 2x 2x 1 mm <sup>2</sup> , 8-pin Intercontec motor connector, can be used in drag chains, UL/CSA listed	
8CM020.12-3	Motor cable, length 20 m, 4x 4 mm <sup>2</sup> + 2x 2x 1 mm <sup>2</sup> , 8-pin Intercontec motor connector, can be used in drag chains, UL/CSA listed	
8CM025.12-3	Motor cable, length 25 m, 4x 4 mm <sup>2</sup> + 2x 2x 1 mm <sup>2</sup> , 8-pin Intercontec motor connector, can be used in drag chains, UL/CSA listed	

Table 136: 8CM005.12-3, 8CM007.12-3, 8CM010.12-3, 8CM015.12-3, 8CM020.12-3, 8CM025.12-3 - Order data

## Information:

Other cable lengths and raw cables are available from B&R upon request.

### 5.2.3.2 Technical data

Product ID	8CM005.12-3	8CM007.12-3	8CM010.12-3	8CM015.12-3	8CM020.12-3	8CM025.12-3
<b>General information</b>						
Cable cross section	4x 4 mm <sup>2</sup> + 2x 2x 1 mm <sup>2</sup>					
Durability	Oil resistance according to VDE 0472 part 803 as well as standard hydraulic oil					
Listed	UL AWM Style 20234, 80°C, 1000 V, E63216 and CSA AWM I/II A/B, 90°C, 1000 V, FT2 LL46064					
Certification c-UL-us	Yes					
<b>Cable structure</b>						
Power lines	4					
Quantity	Special thermoplastic material					
Wire insulation	Black, brown, blue, yellow/green					
Wire colors	Tinned copper litz wire					
Design	4 mm <sup>2</sup>					
Diameter	No					
Shielding	No					
Stranding	4					
Signal lines	Special thermoplastic material					
Quantity	White, white/red, white/blue, white/green					
Wire insulation	Tinned copper litz wire					
Wire colors	1 mm <sup>2</sup>					
Design	Separate shielding for pairs, tinned copper mesh, optical coverage >85% and foil banding					
Diameter	White with white/red and white/blue with white/green					
Shielding	With filler elements and foil banding					
Stranding	Tinned copper mesh, optical coverage >85% and wrapped in isolating film					
Cable stranding	PUR					
Cable shielding	Orange, similar to RAL 2003 flat					
Outer sheathing	BERNECKER & RAINER 4x4.0+2x2x1.0 FLEX					
Material	<b>Electrical characteristics</b>					
Color	Operating voltage					
Labeling	Max. 1000 V					
	Test voltage					
	Wire/Wire					
	Wire/Shield					
	1500 VAC					
	1500 VAC					
	Conductor resistance					
	Power lines					
	Signal lines					
	≤0.03 Ω	≤0.04 Ω	≤0.05 Ω	≤0.08 Ω	≤0.1 Ω	≤0.13 Ω
	≤0.09 Ω	≤0.13 Ω	≤0.19 Ω	≤0.28 Ω	≤0.38 Ω	≤0.48 Ω
	Insulation resistance					
	>40 GΩ	>28.57 GΩ	>20 GΩ	>13.33 GΩ	>10 GΩ	>8 GΩ
	Max. current load in accordance with IEC 60364-5-523 by installation type					
	Wall mounting					
	Installed in conduit or cable duct					
	Installed in cable tray					
	36.4 A					
	31.9 A					
	38.2 A					

Table 137: 8CM005.12-3, 8CM007.12-3, 8CM010.12-3, 8CM015.12-3, 8CM020.12-3, 8CM025.12-3 - Technical data

Product ID	8CM005.12-3	8CM007.12-3	8CM010.12-3	8CM015.12-3	8CM020.12-3	8CM025.12-3
<b>Environmental conditions</b>						
Temperature						
Moving	-10 to 70°C					
Static	-20 to 90°C					
<b>Mechanical characteristics</b>						
Dimensions						
Length	5 m	7 m	10 m	15 m	20 m	25 m
Diameter	15.8 mm ±0.5 mm					
Flex radius						
Single bend	>50 mm					
Moving	≥122 mm					
Drag chain data						
Acceleration	<60 m/s <sup>2</sup>					
Flex cycles	≥3,000,000					
Velocity	≤4 m/s					
Weight	2.21 kg	3 kg	4.31 kg	6.6 kg	9 kg	11.1 kg

Table 137: 8CM005.12-3, 8CM007.12-3, 8CM010.12-3, 8CM015.12-3, 8CM020.12-3, 8CM025.12-3 - Technical data

## 5.2.4 10 mm<sup>2</sup> motor cables

### 5.2.4.1 Order data

Model number	Short description	Figure
<b>10 mm<sup>2</sup> motor cables</b>		
8CM005.12-5	Motor cable, length 5 m, 4x 10 mm <sup>2</sup> + 2x 2x 1.5 mm <sup>2</sup> , 8-pin Intercontec motor connector, can be used in drag chains, UL/CSA listed	
8CM007.12-5	Motor cable, length 7 m, 4x 10 mm <sup>2</sup> + 2x 2x 1.5 mm <sup>2</sup> , 8-pin Intercontec motor connector, can be used in drag chains, UL/CSA listed	
8CM010.12-5	Motor cable, length 10 m, 4x 10 mm <sup>2</sup> + 2x 2x 1.5 mm <sup>2</sup> , 8-pin Intercontec motor connector, can be used in drag chains, UL/CSA listed	
8CM015.12-5	Motor cable, length 15 m, 4x 10 mm <sup>2</sup> + 2x 2x 1.5 mm <sup>2</sup> , 8-pin Intercontec motor connector, can be used in drag chains, UL/CSA listed	
8CM020.12-5	Motor cable, length 20 m, 4x 10 mm <sup>2</sup> + 2x 2x 1.5 mm <sup>2</sup> , 8-pin Intercontec motor connector, can be used in drag chains, UL/CSA listed	
8CM025.12-5	Motor cable, length 25 m, 4x 10 mm <sup>2</sup> + 2x 2x 1.5 mm <sup>2</sup> , 8-pin Intercontec motor connector, can be used in drag chains, UL/CSA listed	

Table 138: 8CM005.12-5, 8CM007.12-5, 8CM010.12-5, 8CM015.12-5, 8CM020.12-5, 8CM025.12-5 - Order data

## Information:

Other cable lengths and raw cables are available from B&R upon request.

### 5.2.4.2 Technical data

Product ID	8CM005.12-5	8CM007.12-5	8CM010.12-5	8CM015.12-5	8CM020.12-5	8CM025.12-5
<b>General information</b>						
Cable cross section	4x 10 mm <sup>2</sup> + 2x 2x 1.5 mm <sup>2</sup>					
Durability	Oil resistance according to VDE 0472 part 803 as well as standard hydraulic oil					
Listed	UL AWM Style 20234, 80°C, 1000 V, E63216 and CSA AWM I/II A/B, 90°C, 1000 V, FT2 LL46064					
Certification c-UL-us	Yes					
<b>Cable structure</b>						
Power lines	4					
Quantity	Special thermoplastic material					
Wire insulation	Black, brown, blue, yellow/green					
Wire colors	Tinned copper litz wire					
Design	10 mm <sup>2</sup>					
Diameter	No					
Shielding	No					
Stranding	No					
Signal lines	4					
Quantity	Special thermoplastic material					
Wire insulation	White, white/red, white/blue, white/green					
Wire colors	Tinned copper litz wire					
Design	1.5 mm <sup>2</sup>					
Diameter	Separate shielding for pairs, tinned copper mesh, optical coverage >85% and foil banding					
Shielding	White with white/red and white/blue with white/green					
Stranding	With filler elements and foil banding					
Cable stranding	Tinned copper mesh, optical coverage >85% and wrapped in isolating film					
Cable shielding	With filler elements and foil banding					
Outer sheathing	PUR					
Material	Orange, similar to RAL 2003 flat					
Color	BERNECKER & RAINER 4x10,0+2x2x1.5 FLEX					
Labeling						
<b>Electrical characteristics</b>						
Operating voltage	Max. 1000 V					
Test voltage	1500 VAC					
Wire/Wire	1500 VAC					
Wire/Shield	1500 VAC					
Conductor resistance						
Power lines	≤0.01 Ω		≤0.02 Ω	≤0.03 Ω	≤0.04 Ω	≤0.05 Ω
Signal lines	≤0.07 Ω	≤0.1 Ω	≤0.14 Ω	≤0.21 Ω	≤0.28 Ω	≤0.35 Ω
Insulation resistance	>40 GΩ	>28.57 GΩ	>20 GΩ	>13.33 GΩ	>10 GΩ	>8 GΩ

Table 139: 8CM005.12-5, 8CM007.12-5, 8CM010.12-5, 8CM015.12-5, 8CM020.12-5, 8CM025.12-5 - Technical data

Product ID	8CM005.12-5	8CM007.12-5	8CM010.12-5	8CM015.12-5	8CM020.12-5	8CM025.12-5
Max. current load in accordance with IEC 60364-5-523 by installation type						
Wall mounting	64.6 A					
Installed in conduit or cable duct	54.6 A					
Installed in cable tray	68.3 A					
<b>Environmental conditions</b>						
Temperature						
Moving	-10 to 70°C					
Static	-20 to 90°C					
<b>Mechanical characteristics</b>						
Dimensions						
Length	5 m	7 m	10 m	15 m	20 m	25 m
Diameter	20.1 mm ±0.7 mm					
Flex radius						
Single bend	>62 mm					
Moving	≥156 mm					
Drag chain data						
Acceleration	<60 m/s <sup>2</sup>					
Flex cycles	≥3,000,000					
Velocity	≤4 m/s					
Weight	4.29 kg	6 kg	8.3 kg	12.2 kg	16 kg	19.9 kg

Table 139: 8CM005.12-5, 8CM007.12-5, 8CM010.12-5, 8CM015.12-5, 8CM020.12-5, 8CM025.12-5 - Technical data

## 5.2.5 35 mm<sup>2</sup> motor cables

### 5.2.5.1 Order data


Model number	Short description	Figure
	<b>35 mm<sup>2</sup> motor cables</b>	
8CM005.12-8	Motor cable, length 5 m, 4x 35 mm <sup>2</sup> + 2x 2x 1.5 mm <sup>2</sup> , not assembled, can be used in drag chains, UL/CSA listed	
8CM007.12-8	Motor cable, length 7 m, 4x 35 mm <sup>2</sup> + 2x 2x 1.5 mm <sup>2</sup> , not assembled, can be used in drag chains, UL/CSA listed	
8CM010.12-8	Motor cable, length 10 m, 4x 35 mm <sup>2</sup> + 2x 2x 1.5 mm <sup>2</sup> , not assembled, can be used in drag chains, UL/CSA listed	
8CM015.12-8	Motor cable, length 15 m, 4x 35 mm <sup>2</sup> + 2x 2x 1.5 mm <sup>2</sup> , not assembled, can be used in drag chains, UL/CSA listed	
8CM020.12-8	Motor cable, length 20 m, 4x 35 mm <sup>2</sup> + 2x 2x 1.5 mm <sup>2</sup> , not assembled, can be used in drag chains, UL/CSA listed	
8CM025.12-8	Motor cable, length 25 m, 4x 35 mm <sup>2</sup> + 2x 2x 1.5 mm <sup>2</sup> , not assembled, can be used in drag chains, UL/CSA listed	

Table 140: 8CM005.12-8, 8CM007.12-8, 8CM010.12-8, 8CM015.12-8, 8CM020.12-8, 8CM025.12-8 - Order data

## Information:

Other cable lengths and raw cables are available from B&R upon request.

### 5.2.5.2 Technical data

Product ID	8CM005.12-8	8CM007.12-8	8CM010.12-8	8CM015.12-8	8CM020.12-8	8CM025.12-8
<b>General information</b>						
Cable cross section	4x 35 mm <sup>2</sup> + 2x 2x 1.5 mm <sup>2</sup>					
Durability	Oil resistance according to VDE 0472 part 803 as well as standard hydraulic oil					
Listed	UL AWM Style 20669, 90°C, 600 V, E63216 and CSA AWM I/II A/B, 90°C, 600 V, FT1 LL46064					
<b>Cable structure</b>						
Power lines	Special thermoplastic material					
Wire insulation	Black, brown, blue, yellow/green					
Wire colors	Tinned copper litz wire					
Design	35 mm <sup>2</sup>					
Diameter	No					
Shielding	No					
Stranding	No					
Signal lines	Special thermoplastic material					
Wire insulation	White, white/red, white/blue, white/green					
Wire colors	Tinned copper litz wire					
Design	1.5 mm <sup>2</sup>					
Diameter	Separate shielding for pairs, tinned copper mesh, optical coverage >85% and foil banding					
Shielding	White with white/red and white/blue with white/green					
Stranding	With filler elements and foil banding					
Cable stranding	Tinned copper mesh, optical coverage >85% and wrapped in isolating film					
Cable shielding						
Outer sheathing	PUR					
Material	Orange, similar to RAL 2003 flat					
Color	BERNECKER & RAINER 4x35.0+2x2x1.5 FLEX					
Labeling						
<b>Electrical characteristics</b>						
Operating voltage	Max. 600 V					
Test voltage	1500 VAC					
Wire/Wire	1500 VAC					
Wire/Shield	1500 VAC					
Conductor resistance						
Power lines	≤0.003 Ω	≤0.004 Ω	≤0.006 Ω	≤0.009 Ω	≤0.01 Ω	
Signal lines	≤0.07 Ω	≤0.1 Ω	≤0.14 Ω	≤0.21 Ω	≤0.28 Ω	≤0.35 Ω
Insulation resistance	>40 GΩ	>28.57 GΩ	>20 GΩ	>13.33 GΩ	>10 GΩ	>8 GΩ
Max. current load in accordance with IEC 60364-5-523 by installation type						
Wall mounting	133.8 A					
Installed in conduit or cable duct	116.5 A					
Installed in cable tray	143.8 A					
<b>Environmental conditions</b>						
Temperature						
Moving	-10 to 70°C					
Static	-20 to 90°C					

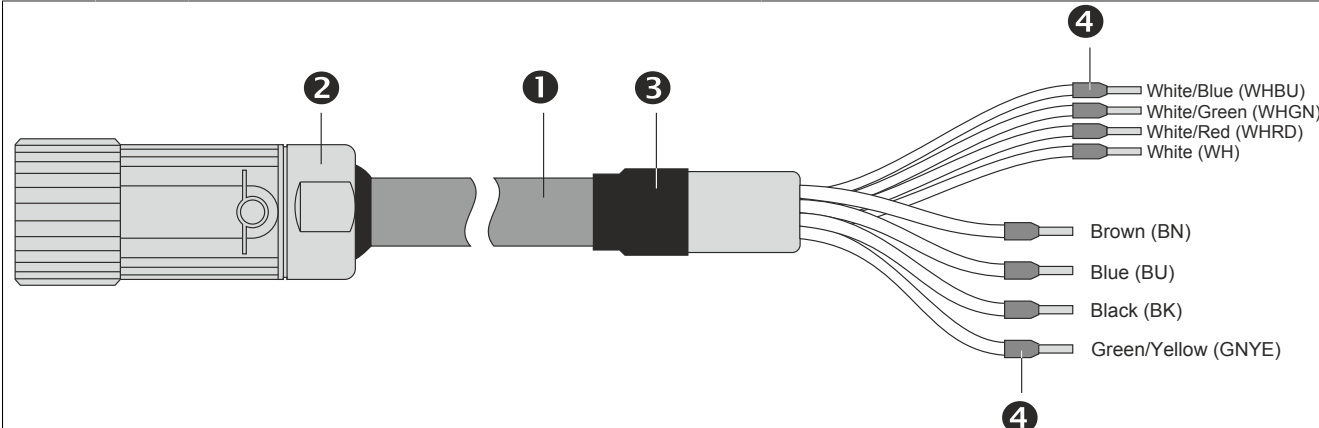
Table 141: 8CM005.12-8, 8CM007.12-8, 8CM010.12-8, 8CM015.12-8, 8CM020.12-8, 8CM025.12-8 - Technical data

Product ID	8CM005.12-8	8CM007.12-8	8CM010.12-8	8CM015.12-8	8CM020.12-8	8CM025.12-8
<b>Mechanical characteristics</b>						
Dimensions						
Length	5 m	7 m	10 m	15 m	20 m	25 m
Diameter	32.5 mm ±1 mm					
Drag chain data						
Acceleration	<60 m/s <sup>2</sup>					
Flex cycles	≥3,000,000					
Velocity	≤4 m/s					
Weight	11 kg	15.4 kg	22 kg	33 kg	44 kg	55 kg

Table 141: 8CM005.12-8, 8CM007.12-8, 8CM010.12-8, 8CM015.12-8, 8CM020.12-8, 8CM025.12-8 - Technical data

## 5.2.6 Wiring

### 5.2.6.1 Motor cable construction



Pos.	Pieces	Name	Note
1	1	Motor lines	4x 0.75 mm <sup>2</sup> + 2x 2x 0.35 mm <sup>2</sup> 4x 1.5 mm <sup>2</sup> + 2x 2x 0.75 mm <sup>2</sup> 4x 4 mm <sup>2</sup> + 2x 2x 1 mm <sup>2</sup> 4x 10 mm <sup>2</sup> + 2x 2x 1.5 mm <sup>2</sup>
2	1	Circular connector	BSTA 108 FR 19 58 0036 000 (for 8CMxxx.12-0, 8CMxxx.12-1) BSTA 108 FR 35 59 0036 000 (for 8CMxxx.12-3) CSTA 264 FR 48 25 0001 000 (for 8CMxxx.12-5)
3	1	Heat shrink tubing	
4	8	Wire end sleeves	

Table 142: Motor cable construction

### 5.2.6.2 Pinout

#### 5.2.6.2.1 8CMxxx.12-0, 8CMxxx.12-1, 8CMxxx.12-3

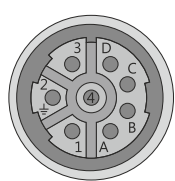
Circular connector	Pin	Name	Function
	1	U	Motor connection U
	2	V	Motor connection V
	3	W	Motor connection W
	4	PE	Protective ground conductor
	A	T+	Temperature +
	B	T-	Temperature -
	C	B+	Brake +
	D	B-	Brake -

Table 143: 8CMxxx.12-0, 8CMxxx.12-1, 8CMxxx.12-3 motor cables - Pinout

5.2.6.2.2 8CMxxx.12-5

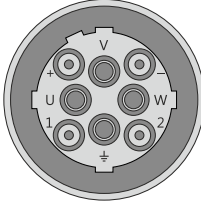
Circular connector	Pin	Name	Function
	U	U	Motor connection U
	V	V	Motor connection V
	W	W	Motor connection W
	⊥	PE	Protective ground conductor
	1	T+	Temperature +
	2	T-	Temperature -
	+	B+	Brake +
	-	B-	Brake -

Table 144: 8CMxxx.12-5 motor cables - Pinout

5.2.6.3 Cable diagram

5.2.6.3.1 8CMxxx.12-0

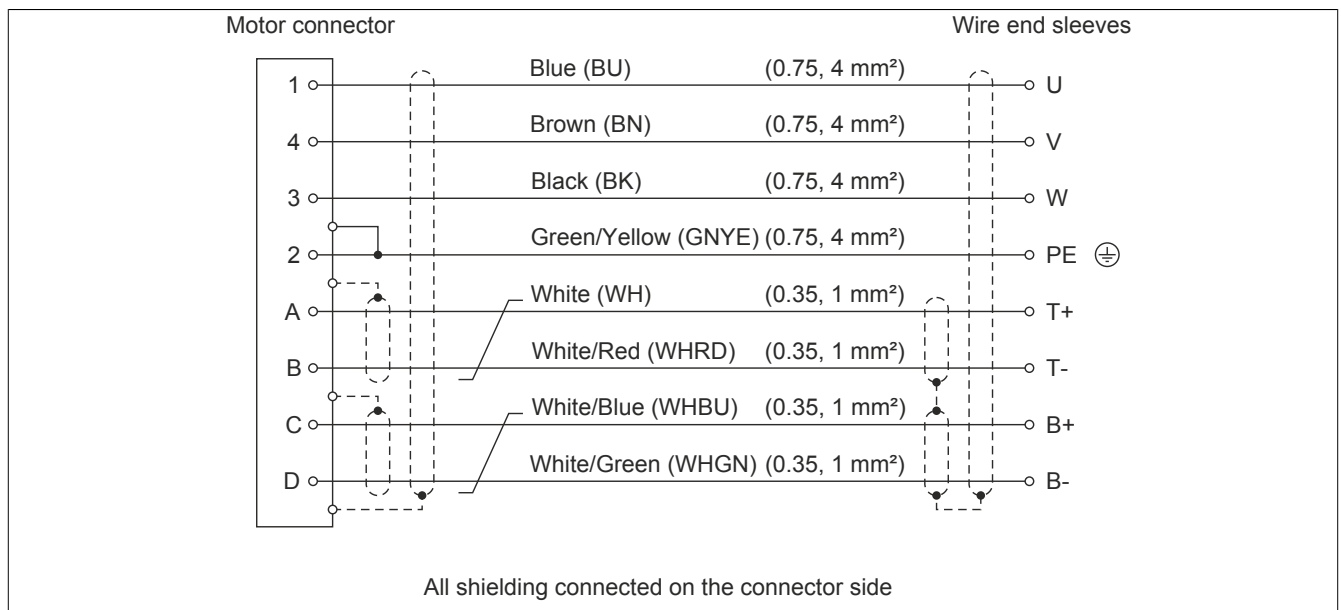


Figure 48: 8CMxxx.12-0 motor cables - Cable diagram

5.2.6.3.2 8CMxxx.12-1, 8CMxxx.12-3

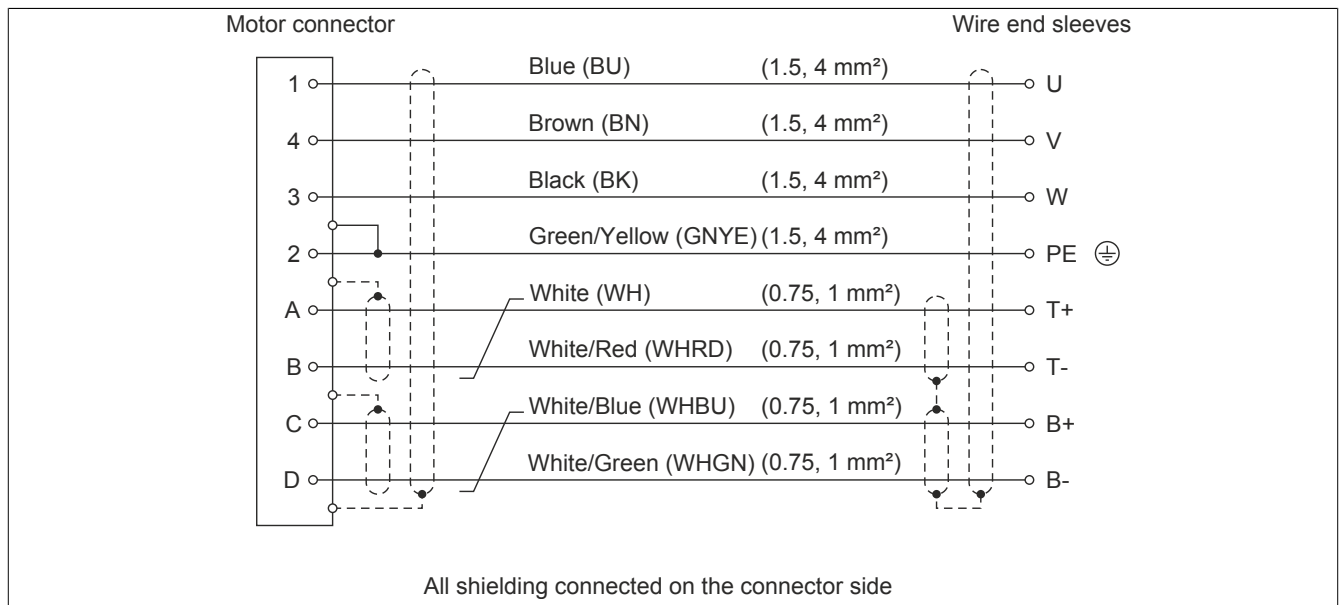


Figure 49: 8CMxxx.12-1, 8CMxxx.12-3 motor cables - Cable diagram

5.2.6.3.3 8CMxxx.12-5

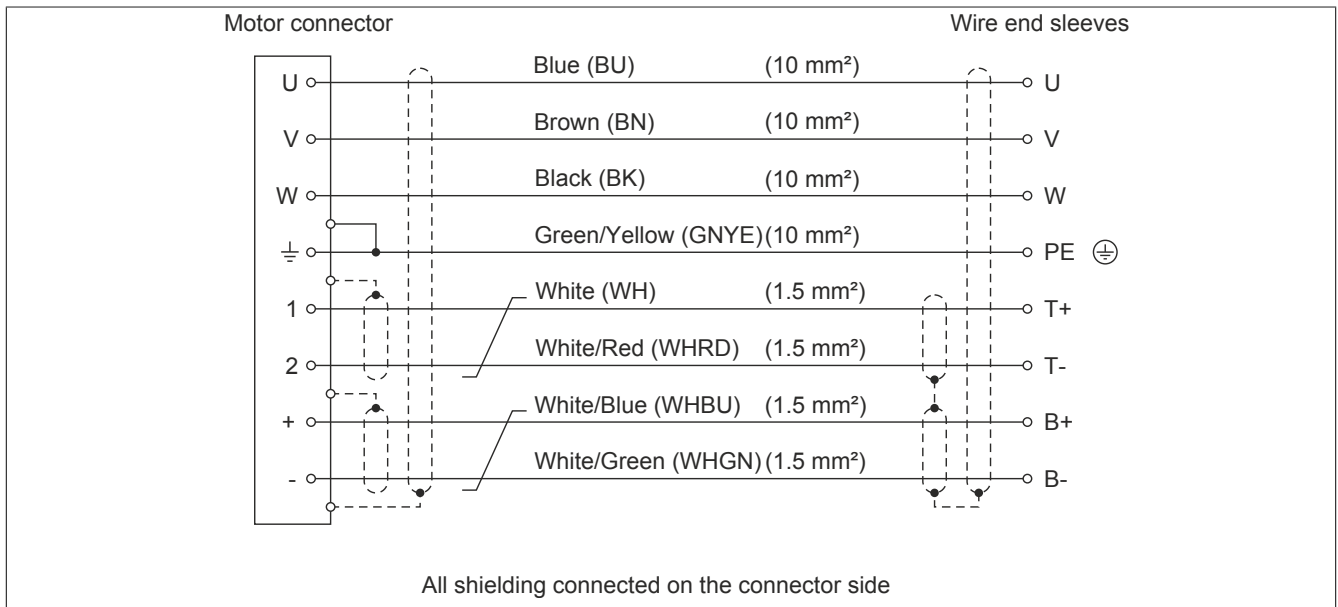


Figure 50: 8CMxxx.12-5 motor cables - Cable diagram

## 5.3 EnDat cables

### 5.3.1 Order data

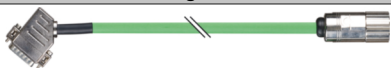
Model number	Short description	Figure
	<b>EnDat cables</b>	
8CE005.12-1	EnDat 2.1 cable, length 5 m, 10x 0.14 mm <sup>2</sup> + 2x 0.5 mm <sup>2</sup> , 17-pin Intercontec EnDat connector, 15-pin DSUB servo connector, can be used in cable drag chains, UL/CSA listed	
8CE007.12-1	EnDat 2.1 cable, length 7 m, 10x 0.14 mm <sup>2</sup> + 2x 0.5 mm <sup>2</sup> , 17-pin Intercontec EnDat connector, 15-pin DSUB servo connector, can be used in cable drag chains, UL/CSA listed	
8CE010.12-1	EnDat 2.1 cable, length 10 m, 10x 0.14 mm <sup>2</sup> + 2x 0.5 mm <sup>2</sup> , 17-pin Intercontec EnDat connector, 15-pin DSUB servo connector, can be used in cable drag chains, UL/CSA listed	
8CE015.12-1	EnDat 2.1 cable, length 15 m, 10x 0.14 mm <sup>2</sup> + 2x 0.5 mm <sup>2</sup> , 17-pin Intercontec EnDat connector, 15-pin DSUB servo connector, can be used in cable drag chains, UL/CSA listed	
8CE020.12-1	EnDat 2.1 cable, length 20 m, 10x 0.14 mm <sup>2</sup> + 2x 0.5 mm <sup>2</sup> , 17-pin Intercontec EnDat connector, 15-pin DSUB servo connector, can be used in cable drag chains, UL/CSA listed	
8CE025.12-1	EnDat 2.1 cable, length 25 m, 10x 0.14 mm <sup>2</sup> + 2x 0.5 mm <sup>2</sup> , 17-pin Intercontec EnDat connector, 15-pin DSUB servo connector, can be used in cable drag chains, UL/CSA listed	

Table 145: 8CE005.12-1, 8CE007.12-1, 8CE010.12-1, 8CE015.12-1, 8CE020.12-1, 8CE025.12-1 - Order data

## Information:

Other cable lengths and raw cables are available from B&R upon request.

### 5.3.2 Technical data

Product ID	8CE005.12-1	8CE007.12-1	8CE010.12-1	8CE015.12-1	8CE020.12-1	8CE025.12-1
<b>General information</b>						
Cable cross section	10x 0.14 mm <sup>2</sup> + 2x 0.50 mm <sup>2</sup>					
Durability	Oil resistance according to VDE 0472 part 803 as well as standard hydraulic oil					
Listed	UL AWM Style 20963, 80°C, 30 V, E63216 and CSA AWM I/II A/B, 90°C, 30 V, FT1 LL46064					
Certification c-UL-us	Yes					
<b>Cable structure</b>						
Supply lines	2					
Quantity	Special thermoplastic material					
Wire insulation	White/Green, white/red					
Wire colors	Tinned copper litz wire					
Design	0.5 mm <sup>2</sup>					
Diameter	No					
Shielding	White/Red with white/green and filler elements					
Stranding						
Signal lines	10					
Quantity	Special thermoplastic material					
Wire insulation	Blue, brown, yellow, gray, green, pink, red, black, violet, white					
Wire colors	Tinned copper litz wire					
Design	0.14 mm <sup>2</sup>					
Diameter	No					
Shielding	Green with brown, gray with yellow, white with violet, black with red, pink with blue					
Stranding						
Cable stranding	With foil banding					
Cable shielding	Copper mesh, optical coverage >85% and wrapped in isolating film					
Outer sheathing						
Material	PUR					
Color	RAL 6018					
Labeling	BERNECKER & RAINER 10x0.14+2x0.50 FLEX					
<b>Electrical characteristics</b>						
Operating voltage	Max. 30 V					
Test voltage						
Wire/Wire	1.5 kV					
Wire/Shield	0.8 kV					
Conductor resistance						
Supply lines	≤0.2 Ω	≤0.28 Ω	≤0.4 Ω	≤0.6 Ω	≤0.8 Ω	≤1 Ω
Signal lines	≤0.7 Ω	≤0.98 Ω	≤1.4 Ω	≤2.1 Ω	≤2.8 Ω	≤3.5 Ω
Insulation resistance	>40 GΩ	>28.57 GΩ	>20 GΩ	>13.33 GΩ	>10 GΩ	>8 GΩ

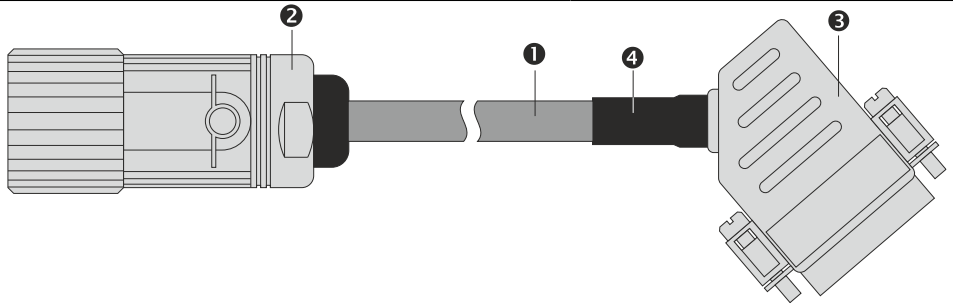
Table 146: 8CE005.12-1, 8CE007.12-1, 8CE010.12-1, 8CE015.12-1, 8CE020.12-1, 8CE025.12-1 - Technical data

Product ID	8CE005.12-1	8CE007.12-1	8CE010.12-1	8CE015.12-1	8CE020.12-1	8CE025.12-1
<b>Environmental conditions</b>						
Temperature						
Moving	-10 to 70°C					
Static	-20 to 90°C					
<b>Mechanical characteristics</b>						
Dimensions						
Length	5 m	7 m	10 m	15 m	20 m	25 m
Diameter	7.3 mm ±0.25 mm					
Flex radius						
Single bend	≥24 mm					
Moving	≥60 mm					
Drag chain data						
Acceleration	<60 m/s <sup>2</sup>					
Flex cycles	≥3,000,000					
Velocity	≤4 m/s					
Weight	0.51 kg	0.7 kg	0.95 kg	1.36 kg	1.77 kg	2.2 kg

Table 146: 8CE005.12-1, 8CE007.12-1, 8CE010.12-1, 8CE015.12-1, 8CE020.12-1, 8CE025.12-1 - Technical data

### 5.3.3 Wiring

#### 5.3.3.1 EnDat encoder cable construction



Pos.	Pieces	Name	Note
1	1	Encoder cable	10x 0.14 mm <sup>2</sup> + 2x 0.50 mm <sup>2</sup>
2	1	Circular connector, 17-pin socket	ASTA 035 FR 11 10 0035 000
3	1	DSUB housing 45°, metal plated, 15-pin connector	
4	1	Heat shrink tubing	

Table 147: EnDat encoder cable construction

#### 5.3.3.2 Pinout

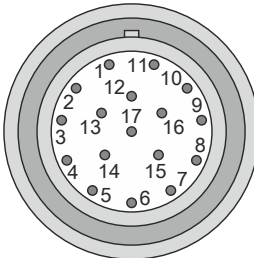
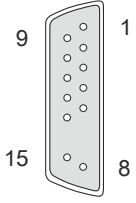
Circular connector	Pin	Name	Function	Pin	DSUB connector
	15	A	Channel A	1	
	10	COM (1, 3 - 9, 11, 13 - 15)	Encoder supply 0 V	2	
	12	B	Channel B	3	
	7	+5V out / 0.25A	Encoder supply +5 V	4	
	14	B	Data input	5	
	8	T	Clock output	8	
	16	A\	Channel A inverted	9	
	4	Sense COM	Sense input 0 V	10	
	13	B\	Channel B inverted	11	
	1	Sense +5V	Sense input +5 V	12	
	17	D\	Data inverted	13	
	9	T\	Clock output inverted	15	

Table 148: EnDat encoder cables - Pinout

5.3.3.3 Cable diagram

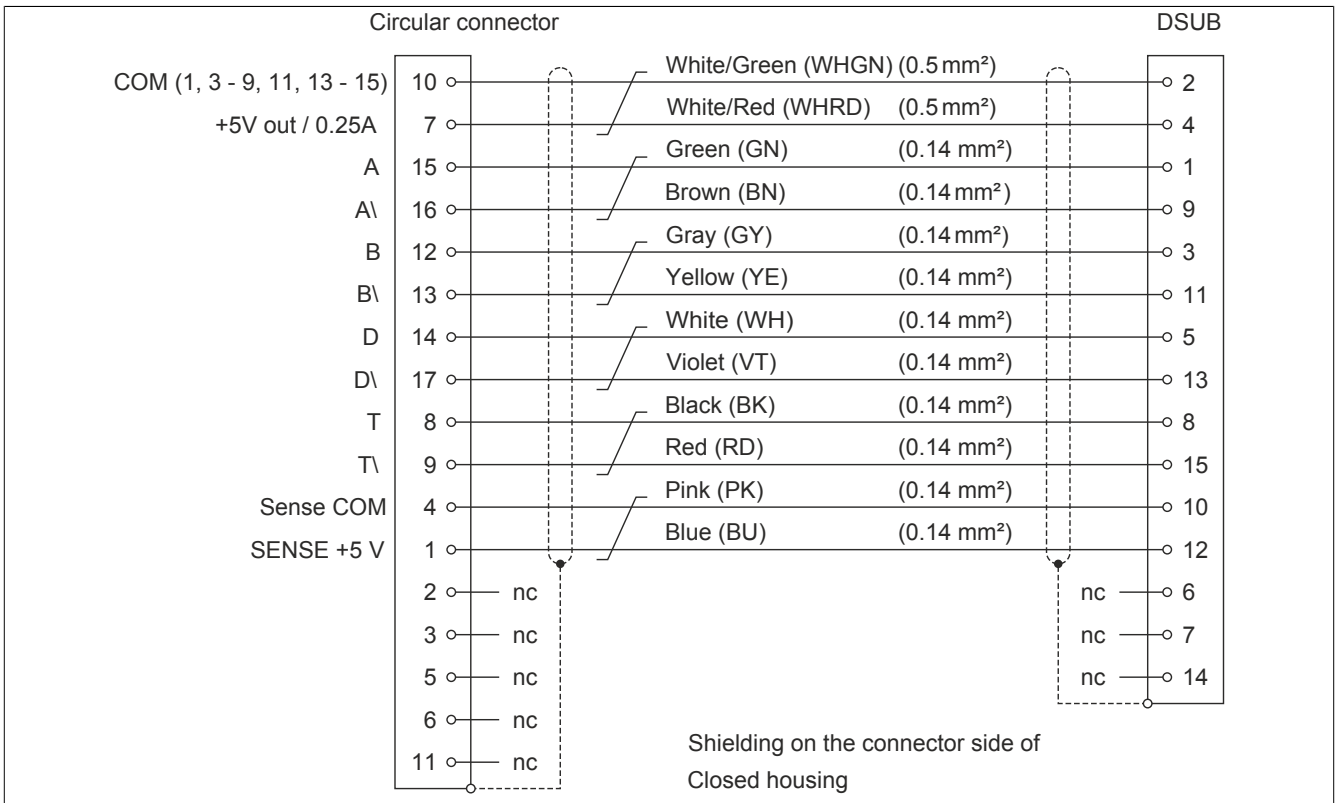


Figure 51: EnDat encoder cables - Cable diagram

## 5.4 Resolver cables

### 5.4.1 Order data

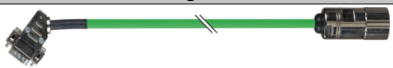
Model number	Short description	Figure
	<b>Resolver cables</b>	
8CR005.12-1	Resolver cable, length 5 m, 3x 2x AWG 24 (19x 0.127), 12-pin Intercontec resolver connector, 9-pin DSUB servo connector, can be used in cable drag chains, UL/CSA listed	
8CR007.12-1	Resolver cable, length 7 m, 3x 2x AWG 24 (19x 0.127), 12-pin Intercontec resolver connector, 9-pin DSUB servo connector, can be used in cable drag chains, UL/CSA listed	
8CR010.12-1	Resolver cable, length 10 m, 3x 2x AWG 24 (19x 0.127), 12-pin Intercontec resolver connector, 9-pin DSUB servo connector, can be used in cable drag chains, UL/CSA listed	
8CR015.12-1	Resolver cable, length 15 m, 3x 2x AWG 24 (19x 0.127), 12-pin Intercontec resolver connector, 9-pin DSUB servo connector, can be used in cable drag chains, UL/CSA listed	
8CR020.12-1	Resolver cable, length 20 m, 3x 2x AWG 24 (19x 0.127), 12-pin Intercontec resolver connector, 9-pin DSUB servo connector, can be used in cable drag chains, UL/CSA listed	
8CR025.12-1	Resolver cable, length 25 m, 3x 2x AWG 24 (19x 0.127), 12-pin Intercontec resolver connector, 9-pin DSUB servo connector, can be used in cable drag chains, UL/CSA listed	

Table 149: 8CR005.12-1, 8CR007.12-1, 8CR010.12-1, 8CR015.12-1, 8CR020.12-1, 8CR025.12-1 - Order data

### Information:

Other cable lengths and raw cables are available from B&R upon request.

### 5.4.2 Technical data

Product ID	8CR005.12-1	8CR007.12-1	8CR010.12-1	8CR015.12-1	8CR020.12-1	8CR025.12-1
<b>General information</b>						
Cable cross section	3x 2x 24 19 AWG					
Durability	Oil resistance according to VDE 0472 part 803 as well as standard hydraulic oil					
Listed	UL AWM Style 20671, 90°C, 30 V, E63216 and CSA AWM, 90°C, 30 V, I/II A/B FT1 LL46064					
Certification c-UL-us	Yes					
<b>Cable structure</b>						
Signal lines	6					
Quantity	Special thermoplastic material					
Wire insulation	White, brown, green, yellow, gray, pink					
Wire colors	Tinned copper litz wire					
Design	AWG 24 / AWG 19					
Diameter	No					
Shielding	White with brown, green with yellow, gray with pink					
Stranding	The 3 pairs together covered by foil banding					
Cable stranding	Copper mesh, optical coverage $\geq 90\%$ and wrapped in isolating film					
Cable shielding						
Outer sheathing	PUR					
Material	RAL 6018					
Color	BERNECKER & RAINER 3x2x24 AWG FLEX					
Labeling						
<b>Electrical characteristics</b>						
Operating voltage	Max. 30 V					
Test voltage						
Wire/Wire	1.5 kV					
Wire/Shield	0.8 kV					
Conductor resistance						
Signal lines	$\leq 0.43 \Omega$	$\leq 0.6 \Omega$	$\leq 0.86 \Omega$	$\leq 1.29 \Omega$	$\leq 1.72 \Omega$	$\leq 2.15 \Omega$
Insulation resistance	$>40 \text{ G}\Omega$	$>28.57 \text{ G}\Omega$	$>20 \text{ G}\Omega$	$>13.33 \text{ G}\Omega$	$>10 \text{ G}\Omega$	$>8 \text{ G}\Omega$
<b>Environmental conditions</b>						
Temperature						
Moving	-10 to 80°C					
Static	-40 to 90°C					
<b>Mechanical characteristics</b>						
Dimensions						
Length	5 m	7 m	10 m	15 m	20 m	25 m
Diameter	6.5 mm $\pm 0.2$ mm					
Flex radius						
Single bend	$\geq 20$ mm					
Moving	$\geq 50$ mm					

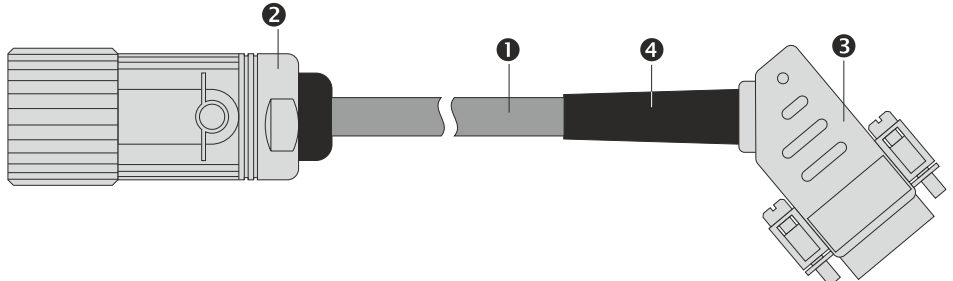
Table 150: 8CR005.12-1, 8CR007.12-1, 8CR010.12-1, 8CR015.12-1, 8CR020.12-1, 8CR025.12-1 - Technical data

Product ID	8CR005.12-1	8CR007.12-1	8CR010.12-1	8CR015.12-1	8CR020.12-1	8CR025.12-1
Drag chain data						
Acceleration	<60 m/s <sup>2</sup>					
Flex cycles	≥3,000,000					
Velocity	≤4 m/s					
Weight	0.4 kg	0.51 kg	0.75 kg	0.98 kg	1.26 kg	1.55 kg

Table 150: 8CR005.12-1, 8CR007.12-1, 8CR010.12-1, 8CR015.12-1, 8CR020.12-1, 8CR025.12-1 - Technical data

### 5.4.3 Wiring

#### 5.4.3.1 Resolver cable construction



Pos.	Pieces	Name	Note
1	1	Encoder cable	3x 2x 24 AWG/19
2	1	Circular connector, 12-pin socket	ASTA 021 FR 11 10 0035 000
3	1	DSUB housing 45°, metal plated, 9-pin connector	
4	1	Kink protection	

Table 151: Resolver cable construction

#### 5.4.3.2 Pinout

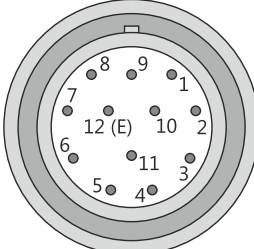
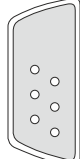
Circular connector	Pin	Name	Function	Pin	DSUB connector
	1	---			
	2	---			
	3	P4	Sine input +	3	
	4	S1	Cosine input -	4	
	5	R2	Reference output +	5	
	6	---			
	7	S2	Sine input -	7	
	8	S3	Cosine input +	8	
	9	R1	Reference output -	9	
	10	---			
	11	---			
	12	---			

Table 152: Resolver cables - Pinout

5.4.3.3 Cable diagram

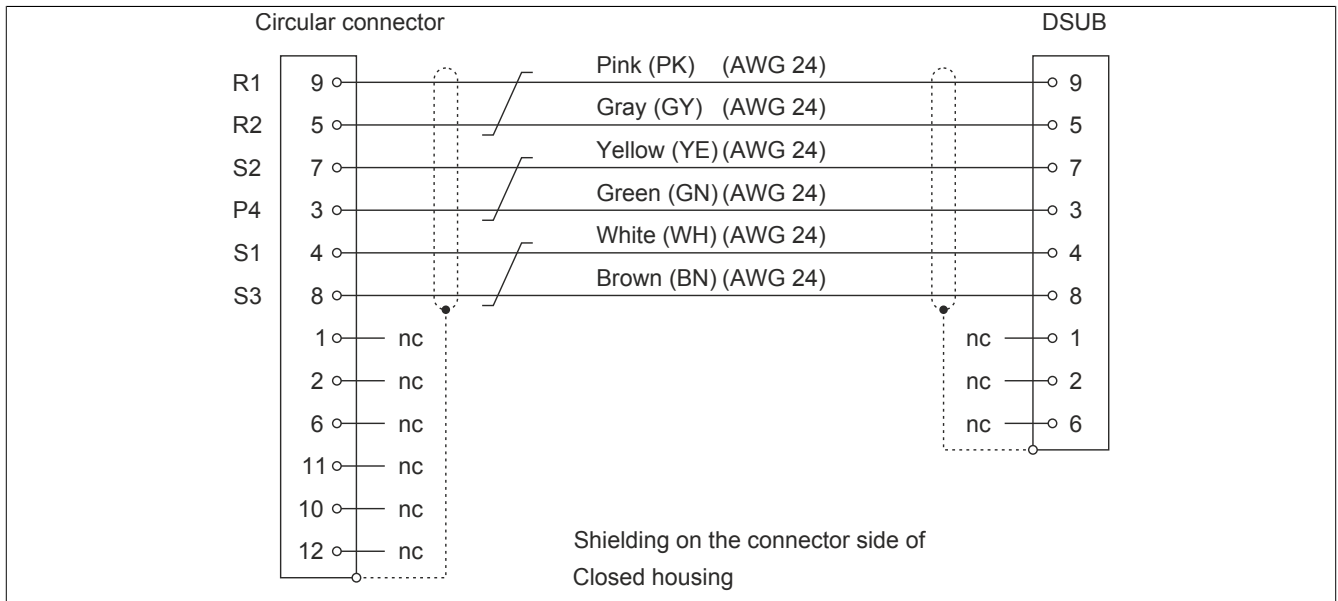


Figure 52: Cable diagram for resolver cables

## 6 Connectors

### 6.1 General information

B&R offers different motor/encoder connectors for B&R motors. All connectors have IP67 protection. The metallic housing provides a protective ground connection on the housing according to VDE 0627. All plastic used in the connector is UL94/V0 listed. High quality, gold-plated cage connector contacts guarantee a high level of contact stability even when reinserted many times.

#### Information:

Using B&R connectors guarantees that the EMC limits for the connection are not exceeded. Make sure that connectors are assembled correctly and include a proper shield connection.

### 6.2 Motor connectors

#### 6.2.1 Order data


Model number	Short description	Figure
	<b>Accessories</b>	
8PM001.00-1	Motor plug 8 pin Intercontec socket, Crimp range 4x 0.5-2.5 mm <sup>2</sup> + 4x 0.06-1.0 mm <sup>2</sup> , for cable 9-14 mm, IP67, UL/CSA listed	
8PM002.00-1	Motor plug 8 pin Intercontec socket, Crimp range 4x 2.5-4.0 mm <sup>2</sup> + 4x 0.06-1.0 mm <sup>2</sup> , Lead range 4x 0.5-4.0 mm <sup>2</sup> + 4x 0.06-1.5 mm <sup>2</sup> , for cable 14-17 mm, IP67, UL/CSA listed	
8PM003.00-1	Motor plug 8 pin Intercontec socket, Crimp range 4x 1.5-10 mm <sup>2</sup> + 4x 0.5-2.5 mm <sup>2</sup> for cable 17-26 mm, IP67, UL/CSA listed	

Table 153: 8PM001.00-1, 8PM002.00-1, 8PM003.00-1 - Order data

#### 6.2.2 Technical data

Product ID	8PM001.00-1	8PM002.00-1	8PM003.00-1
<b>General information</b>			
Insulator	PA 6.6 / PBT, UL94/V0 listed		
Contacts	8 (4 power and 4 signal contacts)		
Protective ground connection on housing	According to VDE 0627		
Certification UL/CSA	Yes		
<b>Electrical characteristics</b>			
Overvoltage category	3		
Power contacts			
Contact resistance	<3 mΩ	630 VAC / VDC	<1 mΩ
Nominal voltage			75 A
Nominal current	30 A	6000 V	
Test voltage (L - L)			
Signal contacts			
Contact resistance	<5 mΩ	250 VAC / VDC	<3 mΩ
Nominal voltage			630 VAC / VDC
Nominal current	10 A	2500 V	30 A
Test voltage (L - L)			4000 V
<b>Operating conditions</b>			
Degree of pollution in accordance with EN 60664-1	3		
EN 60529 protection	IP67 when connected		
<b>Environmental conditions</b>			
Temperature Operation	-20 to 130°C		
Altitude Operation	Up to 2000 m		
<b>Mechanical characteristics</b>			
Housing Material	Zinc die cast / brass, nickel plated		Magnesium die cast / aluminum, nickel plated

Table 154: 8PM001.00-1, 8PM002.00-1, 8PM003.00-1 - Technical data

Product ID	8PM001.00-1	8PM002.00-1	8PM003.00-1
Crimp range	4x 0.5 - 2.5 mm <sup>2</sup> + 4x 0.06 - 1 mm <sup>2</sup>	4x 2.5 - 4 mm <sup>2</sup> + 4x 0.06 - 1 mm <sup>2</sup>	4x 1.5 - 10 mm <sup>2</sup> + 4x 0.5 - 2.5 mm <sup>2</sup>
Gasket	FPM / HNBR		
Connector size	Size 1		Size 1.5
Connection cycles	>50		
Cable terminals	9.5 - 14.5 mm	14 to 17 mm	17 to 26 mm
<b>Manufacturer information</b>			
Manufacturer	INTERCONTEC (www.intercontec.biz)		
Manufacturer product ID	BSTA 108 FR 19 58 0036 000	BSTA 108 FR 35 59 0036 000	CSTA 264 FR 48 25 0001 000

Table 154: 8PM001.00-1, 8PM002.00-1, 8PM003.00-1 - Technical data

## 6.3 Encoder connectors

### 6.3.1 EnDat connectors

#### 6.3.1.1 Order data


Model number	Short description	Figure
8PE001.00-1	EnDat plug 17 pin Intercontec socket, Crimp range 17x 0,06-1.0 mm <sup>2</sup> , for cable 9-12 mm, IP67	

Table 155: 8PE001.00-1 - Order data

#### 6.3.1.2 Technical data

Product ID	8PE001.00-1
<b>General information</b>	
Insulator	PA 6.6 / PBT, UL94/V0 listed
Contacts	17 signal contacts
Protective ground connection on housing	According to VDE 0627
Certification UL/CSA	Yes
<b>Electrical characteristics</b>	
Overvoltage category	3
Signal contacts	
Contact resistance	<5 mΩ
Nominal voltage	125 V
Nominal current	9 A
Test voltage (L - L)	2500 V
<b>Operating conditions</b>	
Degree of pollution in accordance with EN 60664-1	3
EN 60529 protection	IP67 when connected
<b>Environmental conditions</b>	
Temperature Operation	-20 to 130°C
Altitude Operation	Up to 2000 m
<b>Mechanical characteristics</b>	
Housing Material	Zinc die cast / brass, nickel-plated
Crimp range	17x 0.06 - 1 mm <sup>2</sup>
Gasket	FPM / HNBR
Connector size	Size 1
Connection cycles	>50
Cable terminals	5.5 to 10.5 mm
<b>Manufacturer information</b>	
Manufacturer	INTERCONTEC (www.intercontec.biz)
Manufacturer product ID	ASTA 035 FR 11 10 0035 000

Table 156: 8PE001.00-1 - Technical data

### 6.3.2 Resolver connectors

#### 6.3.2.1 Order data


Model number	Short description	Figure
8PR001.00-1	<b>Accessories</b> Resolver plug 12 pin Intercontec socket, Crimp range 12x 0,06-1.0 mm <sup>2</sup> , for cable 5.5-10.5 mm, IP67	

Table 157: 8PR001.00-1 - Order data

#### 6.3.2.2 Technical data

Product ID	8PR001.00-1
<b>General information</b>	
Insulator	PA 6.6 / PBT, UL94/V0 listed
Contacts	12 signal contacts
Protective ground connection on housing	According to VDE 0627
Certification UL/CSA	Yes
<b>Electrical characteristics</b>	
Overvoltage category	3
Signal contacts	
Contact resistance	<5 mΩ
Nominal voltage	160 V
Nominal current	9 A
Test voltage (L - L)	2500 V
<b>Operating conditions</b>	
Degree of pollution in accordance with EN 60664-1	3
EN 60529 protection	IP67 when connected
<b>Environmental conditions</b>	
Temperature Operation	-20 to 130°C
Altitude Operation	Up to 2000 m
<b>Mechanical characteristics</b>	
Housing Material	Zinc die cast / brass, nickel-plated
Crimp range	12x 0.06 - 1 mm <sup>2</sup>
Gasket	FPM / HNBR
Connector size	Size 1
Connection cycles	>50
Cable terminals	5.5 to 10.5 mm
<b>Manufacturer information</b>	
Manufacturer	INTERCONTEC ( <a href="http://www.intercontec.biz">www.intercontec.biz</a> )
Manufacturer product ID	ASTA 021 FR 11 10 0035 000

Table 158: 8PR001.00-1 - Technical data



# Chapter 3 • Installation

## 1 General

Installation must take place on a flat surface that is dimensioned correctly. The dimension diagram lists the number and type of mounting screws to be used.

The included eye bolt can be screwed into the top of the device in order to mount the ACOPOS 1640 and ACOPOS 128M:

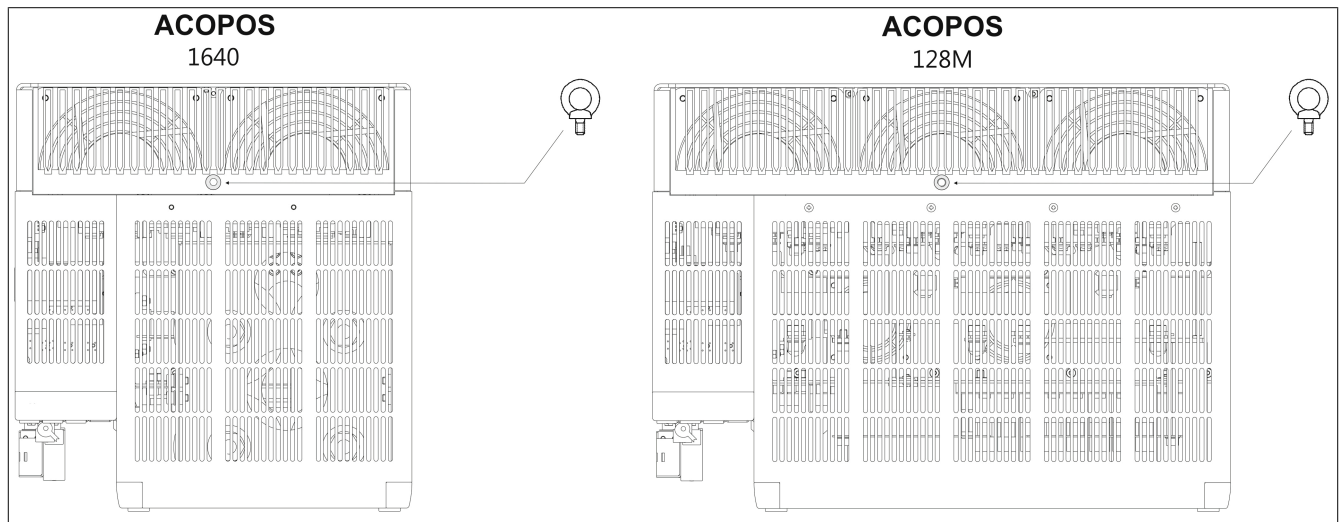


Figure 53: Attaching the eye bolt included in delivery to ACOPOS 1640, 128M drives

ACOPOS servo drives must be installed in control cabinets with at least IP54 protection.

ACOPOS servo drives can only be installed in environments that correspond to a pollution degree 2 (non-conductive pollution). When installing the device, the specifications listed in the technical data for maximum operating temperature and protection level must be met (see "Technical data" on page 29).

Sufficient space of at least 80 mm must be left above and below the ACOPOS servo drives in order to ensure proper air circulation. ACOPOS servo drives can be mounted directly next to each other; the required clearance between devices can be found in the respective dimension diagram.

## 2 Dimension diagrams and installation dimensions

### 2.1 ACOPOS 1010, 1016

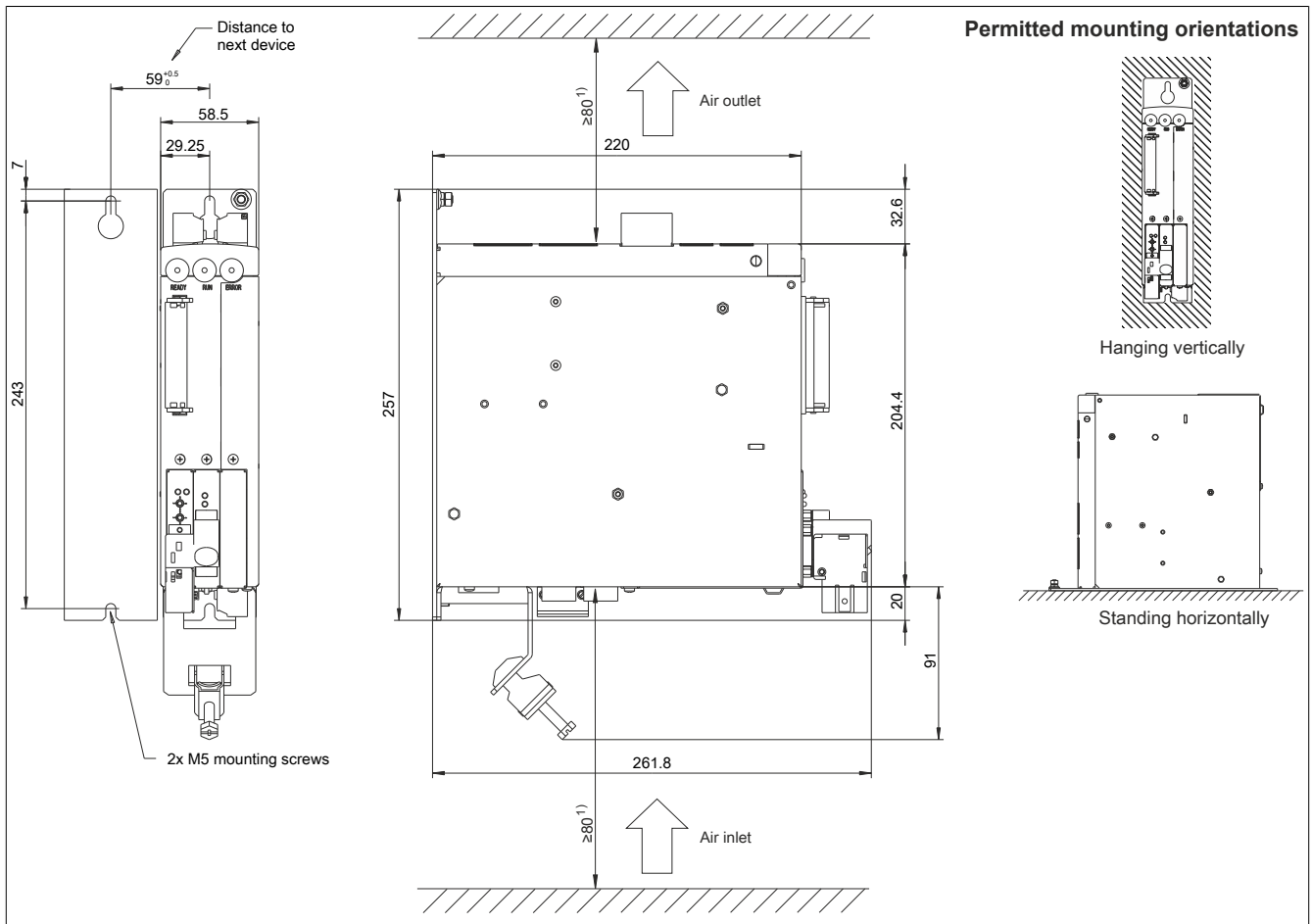


Figure 54: ACOPOS 1010, 1016 - Dimension diagram and installation dimensions

- 1) For proper air circulation, at least 80 mm clearance must be available above and below the ACOPOS servo drive. Approximately 100 mm clearance is required under the ACOPOS servo drive to prevent cabling problems.

2.2 ACOPOS 1022, 1045, 1090

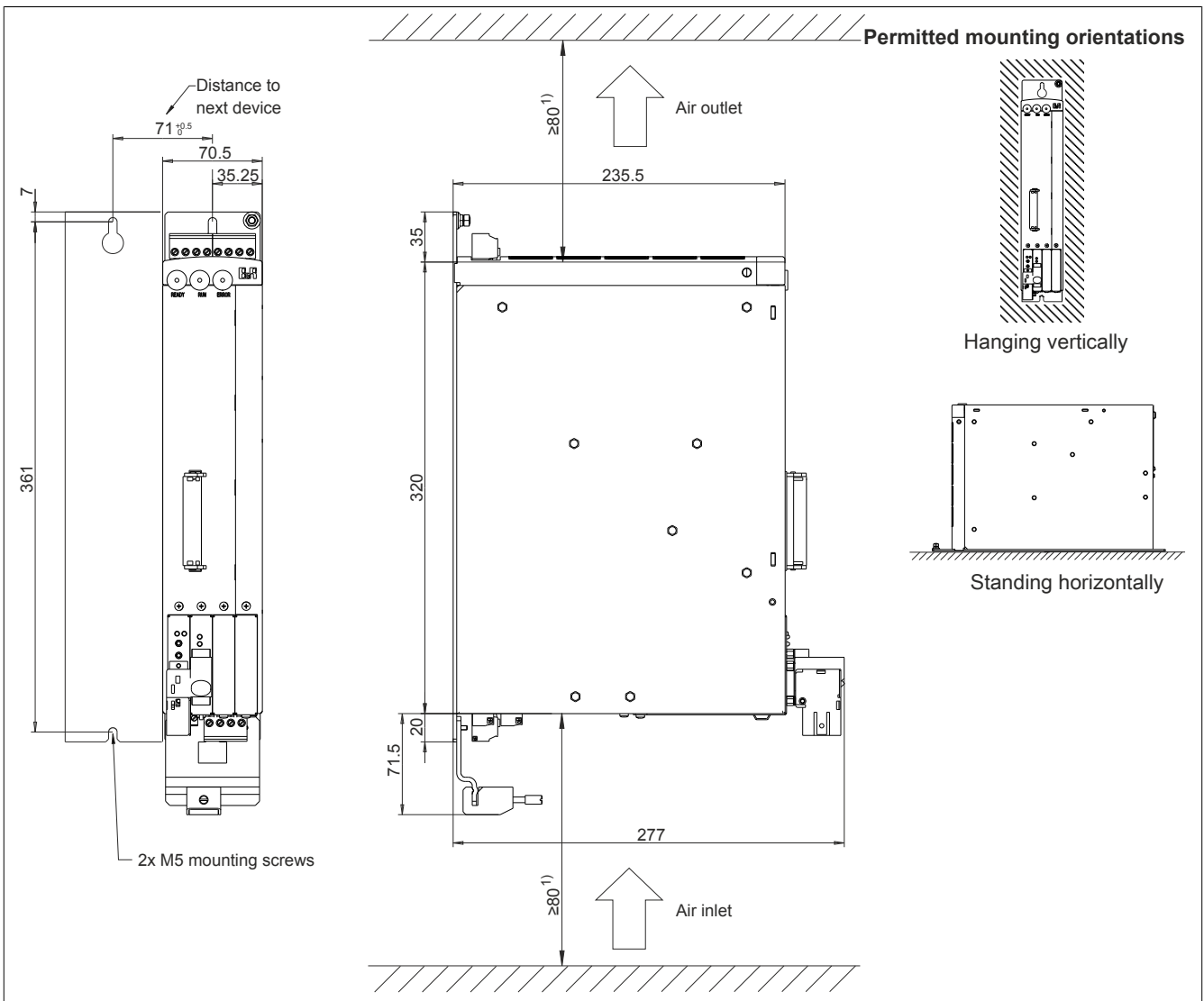


Figure 55: ACOPOS 1022, 1045, 1090 - Dimension diagram and installation dimensions

- 1) For proper air circulation, at least 80 mm clearance must be available above and below the ACOPOS servo drive.

### 2.3 ACOPOS 1180, 1320

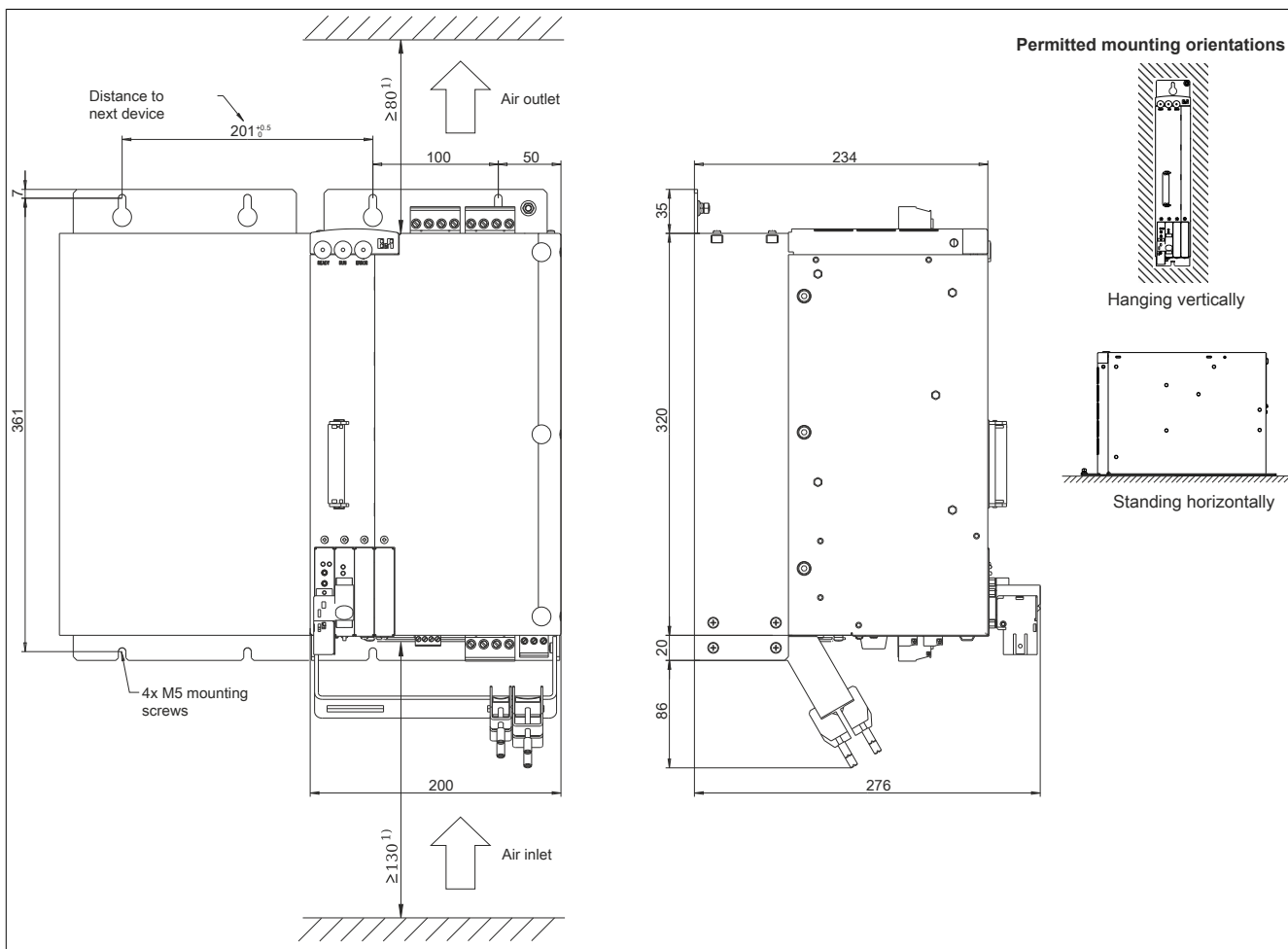


Figure 56: ACOPOS 1180, 1320 - Dimension diagram and installation dimensions

- 1) For proper air circulation, at least 80 mm clearance must be available above and below the ACOPOS servo drive. At least 130 mm free space is required under the ACOPOS servo drive to prevent cabling problems.

2.4 ACOPOS 1640

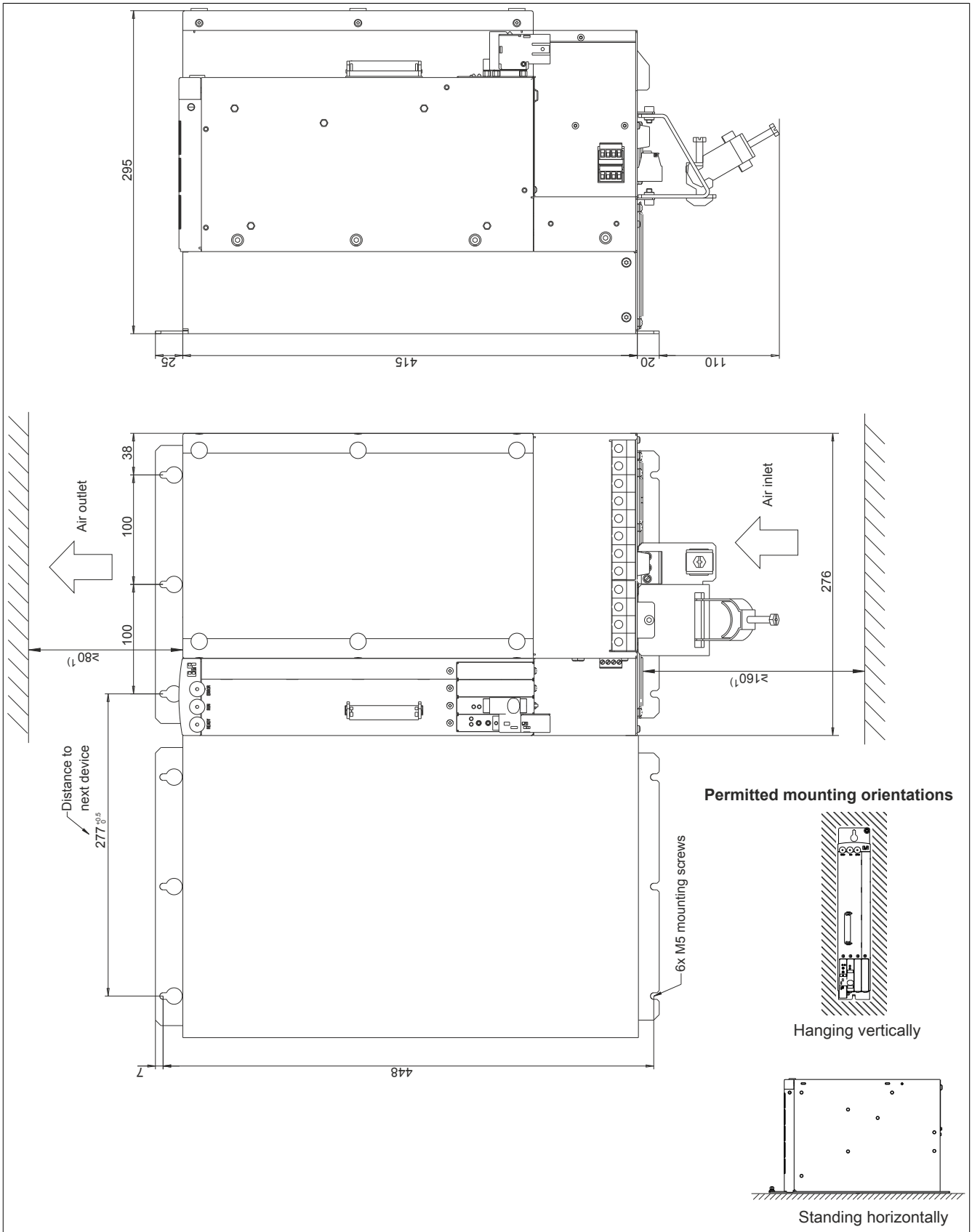


Figure 57: ACOPOS 1640 - Dimension diagram and installation dimensions

- 1) For proper air circulation, at least 80 mm clearance must be available above and below the ACOPOS servo drive. At least 130 mm free space is required under the ACOPOS servo drive to prevent cabling problems.

## 2.5 ACOPOS 128M

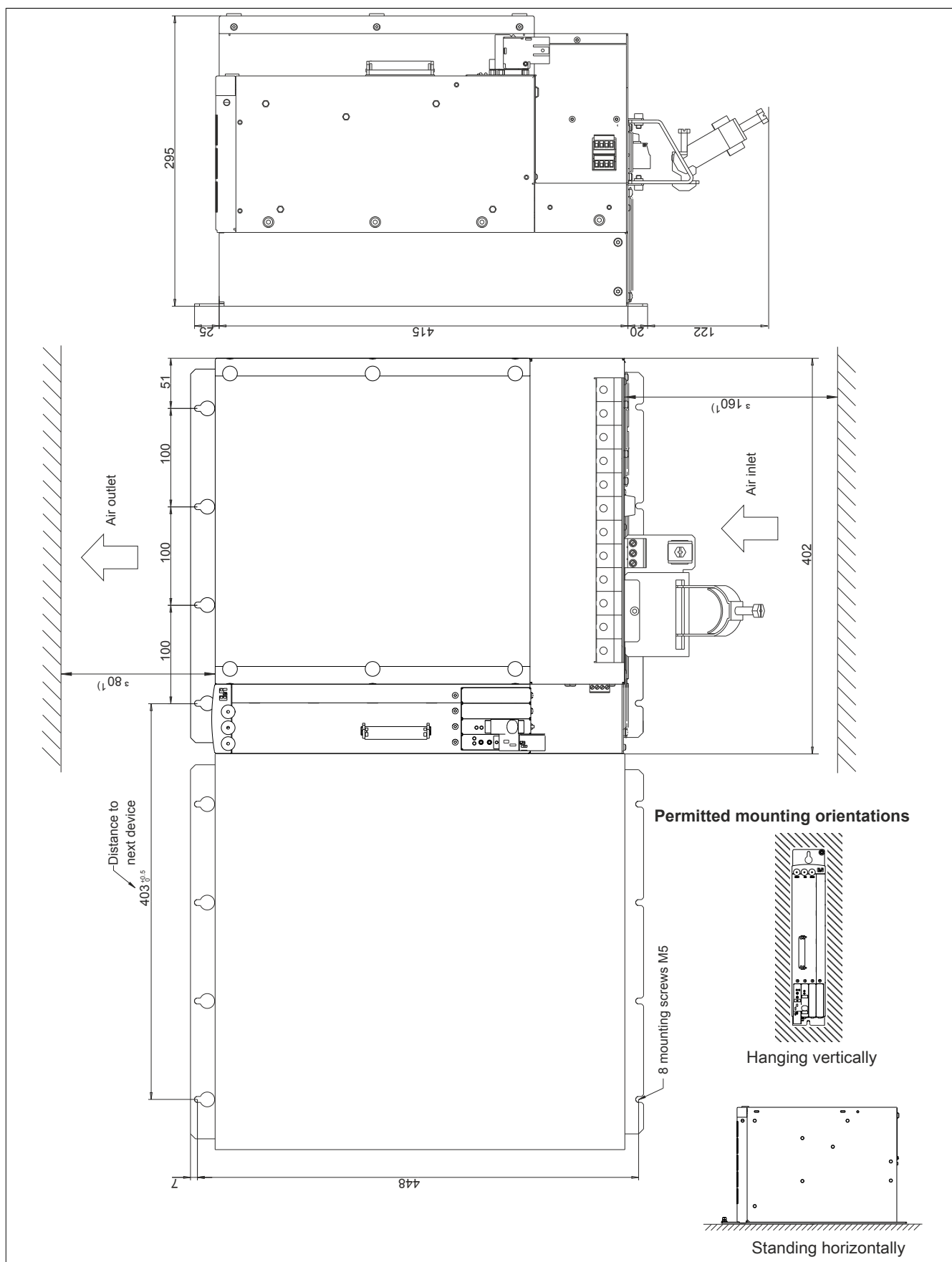


Figure 58: ACOPOS 128M - Dimension diagram and installation dimensions

- 1) For proper air circulation, at least 80 mm clearance must be available above and below the ACOPOS servo drive. Approximately 160 mm clearance is required under the ACOPOS servo drive to prevent cabling problems.

## 2.6 External braking resistors

### 2.6.1 8B0W0045H000.001-1, 8B0W0079H000.001-1

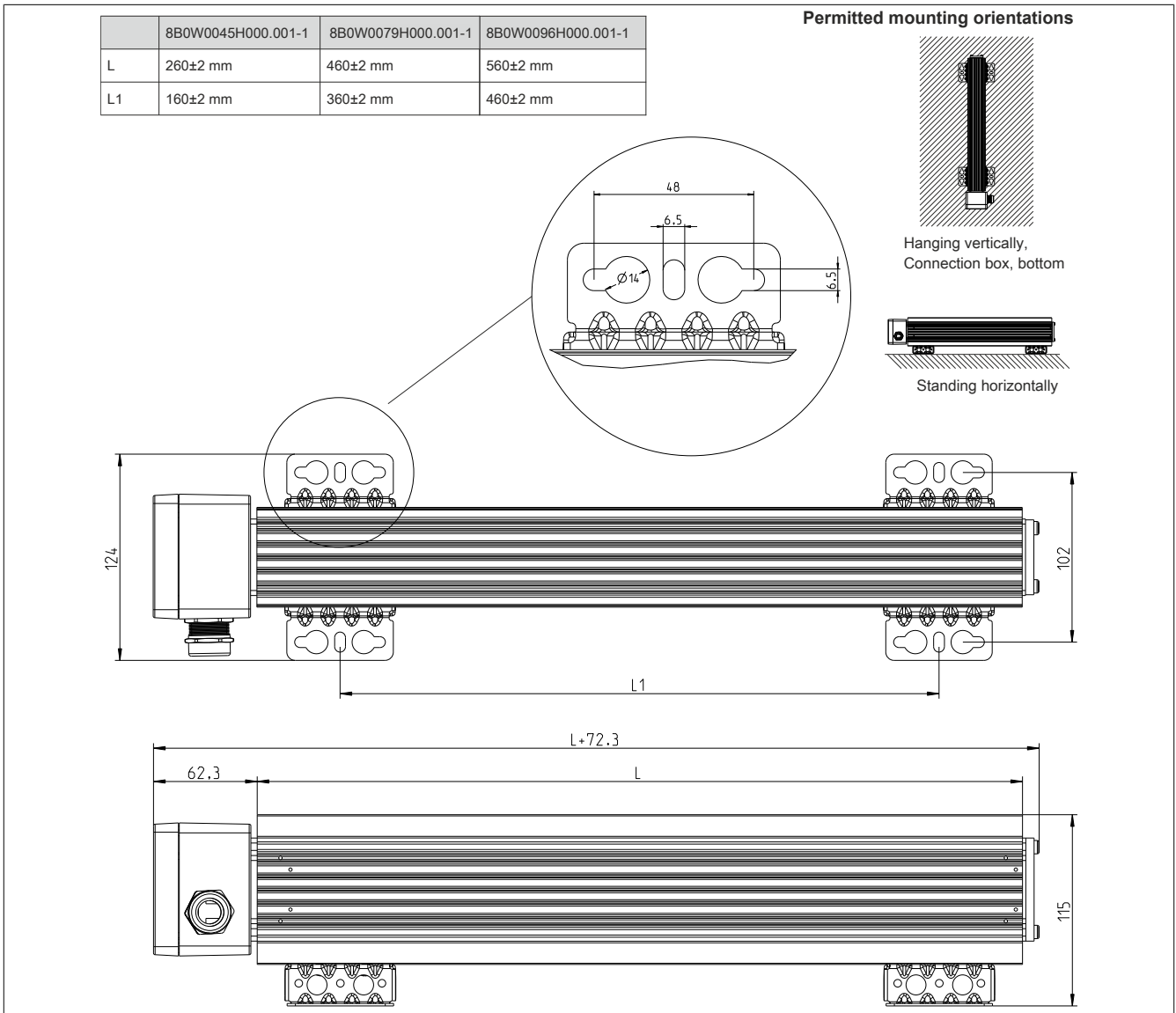


Figure 59: Dimension diagram for 8B0W0045H000.001-1, 8B0W0079H000.001-1

### Warning!

**8B0W external braking resistors can reach extremely high surface temperatures both during operation as well as after being switched off!**

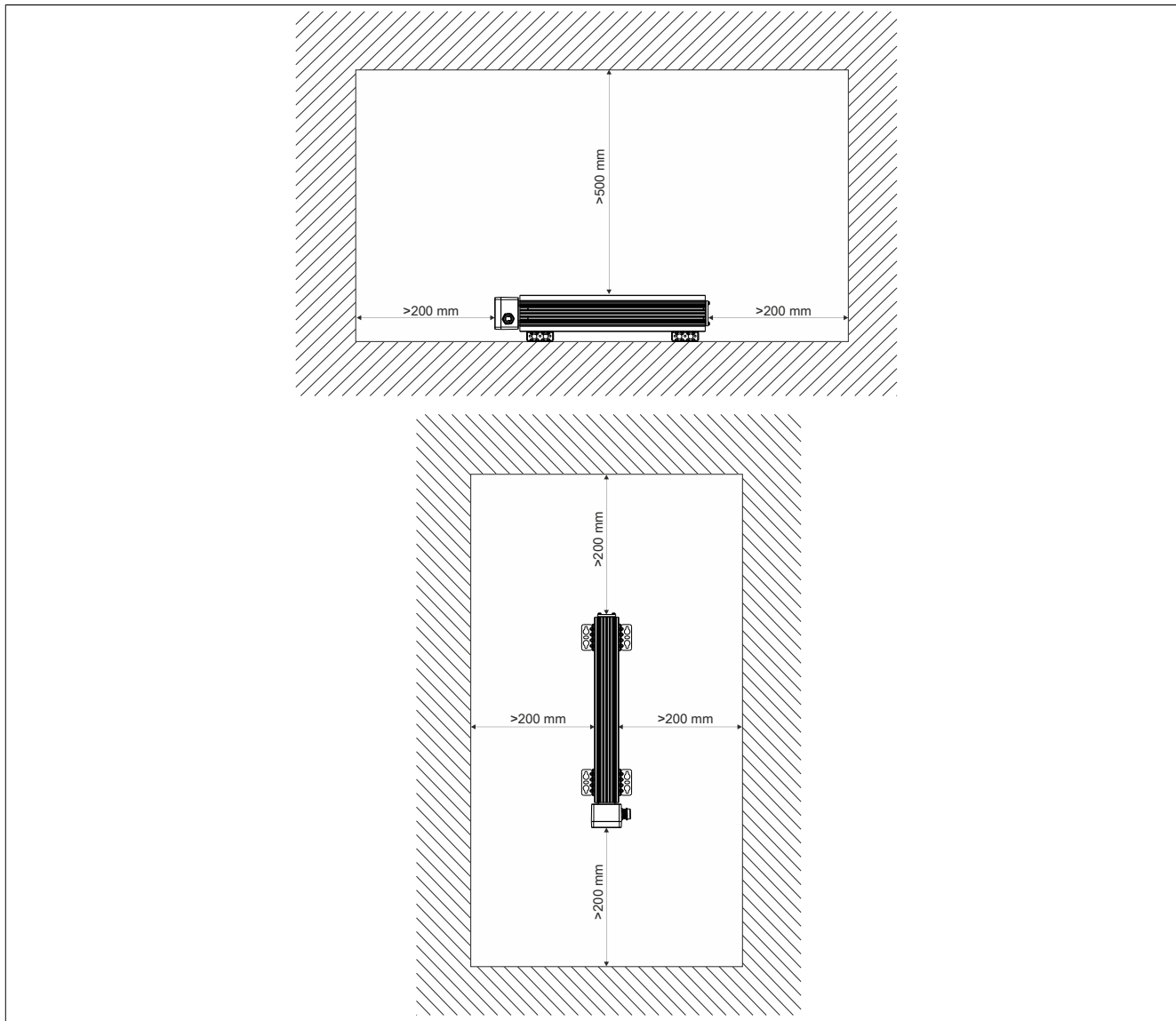


Figure 60: 8B0W external braking resistors - Installation dimensions

### 3 Installing and removing plug-in modules

#### 3.1 General information

All ACOPOS servo drives are equipped with three or four slots for plug-in modules depending on the size of the drive. Currently, the following module arrangements must be used:


Figure	Plug-in module	Operation possible in			
		Slot 1	Slot 2	Slot 3	Slot 4 <sup>1)</sup>
	8AC110.60-2	Yes	No	No	No
	8AC114.60-2	Yes	No	No	No
	8AC120.60-1	No	Yes	Yes	Yes
	8AC121.60-1	No	Yes	Yes	Yes
	8AC122.60-3	No	Yes	Yes	Yes
	8AC123.60-1	No	Yes	Yes	Yes
	8AC125.60-1	No	Yes	Yes	Yes
	8AC126.60-1	No	Yes	Yes	Yes
	8AC130.60-1	No	Yes	Yes	Yes
	8AC131.60-1	No	Yes	Yes	Yes
	8AC140.60-3	Yes <sup>2)</sup>		No	No
	8AC140.61-3	Yes <sup>2)</sup>		No	No
	8AC141.60-2	Yes <sup>2)</sup>		No	No
	8AC141.61-3	Yes <sup>2)</sup>		No	No

Table 159: Slot overview for ACOPOS plug-in modules

- 1) Not available for ACOPOS servo drives 8V1010.xxx-2 and 8V1016.xxx-2.
- 2) This module uses two slots.

#### Caution!

For the installation and removal of plug-in modules, the specifications listed in section "Protection against electrostatic discharge" on page 23 must be followed!

#### 3.2 Installation

1. Disconnect the ACOPOS servo drive from the power mains and prevent reconnection.
2. Switch off the 24 VDC supply voltage.
3. Remove the screw from the bottom of the slot cover.
4. Loosen the screw on the front side.
5. Remove the slot cover.



Figure 61: Installing ACOPOS plug-in modules

6. Insert the plug-in module in available slot (see figure above).
7. Fasten the plug-in module with the two screws.
8. Switch on the 24 VDC supply voltage.
9. Connect the ACOPOS servo drive to the power mains.

### 3.3 Removal

1. Disconnect the ACOPOS servo drive from the power mains and prevent reconnection.
2. Switch off the 24 VDC supply voltage.
3. Remove the screw from bottom of plug-in module.
4. Loosen the screw on the front side of the plug-in module.
5. Remove the plug-in module.
6. Insert the slot cover in the open slot.
7. Fasten the slot cover with the two screws.
8. Switch on the 24 VDC supply voltage.
9. Connect the ACOPOS servo drive to the power mains.

## 4 Installing devices from different ACOPOS series directly next to each other

When installing various ACOPOS series devices directly next to each other, we recommend aligning the vertical position so that the LED displays of the respective devices are lined up.

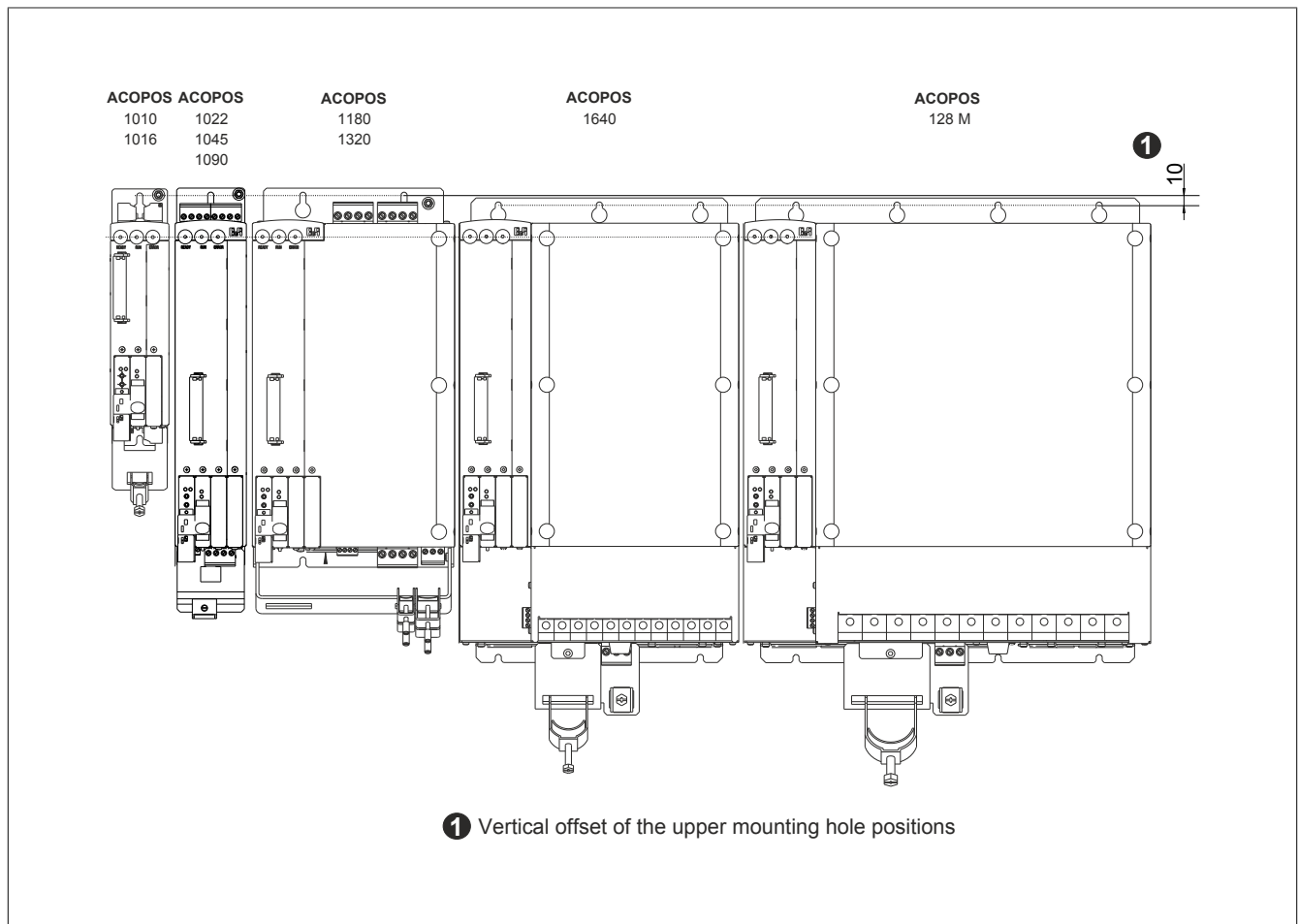


Figure 62: Installing various ACOPOS series devices directly next to each other

You can see from the image above that the vertical offset of the upper mounting holes is 10 mm. The distances for the lower mounting holes and the number and size of the screws required can be taken from the dimensional diagrams for the respective ACOPOS servo drives.

Overview of the vertical offsets:

Installed next to		ACOPOS								
		1010	1016	1022	1045	1090	1180	1320	1640	128 M
ACOPOS	1010	No offset						10 mm		
	1016	No offset						10 mm		
	1022	No offset						10 mm		
	1045	No offset						10 mm		
	1090	No offset						10 mm		
	1180	10 mm						No offset		
	1320	10 mm						No offset		
	1640	10 mm						No offset		
128 M	10 mm						No offset			

Table 160: Overview of the vertical offsets (ACOPOS - ACOPOS)

## 5 Using cooling systems in control cabinets

Cooling systems are generally used to maintain permissible ambient temperature levels of the ACOPOS servo drives in control cabinets.

For details about dimensioning cooling systems, see "Dimensioning cooling systems for cooling control cabinets" on page 230.

### 5.1 Natural convection

#### Warning!

Make sure that only well-sealed control cabinets are used. Otherwise, contaminated ambient air could permeate the control cabinet.

### 5.2 Using filter fans

Filter fans and outlet filters should be arranged on the control cabinet in such a way that the air is taken in from below and exits above.

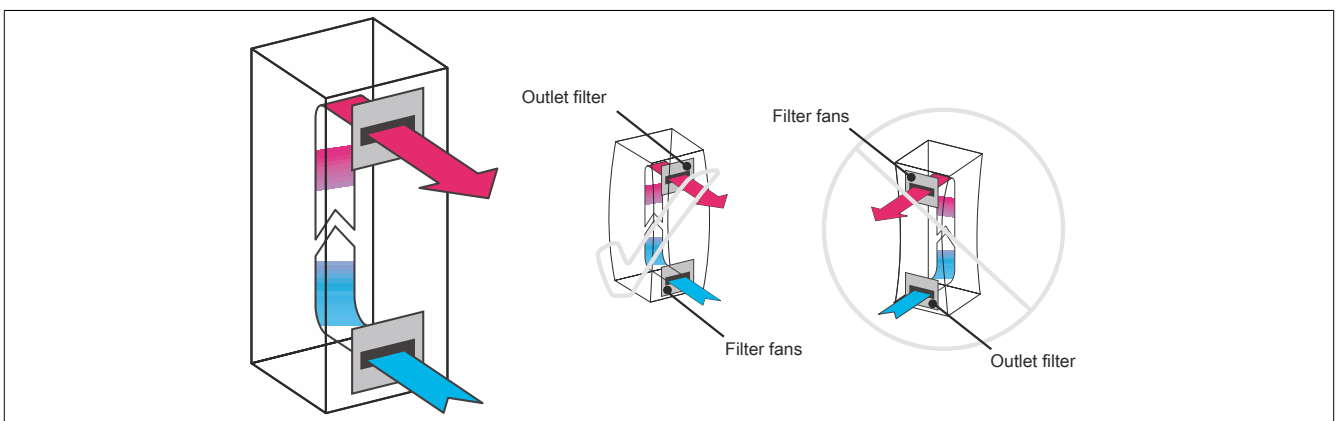


Figure 63: Function diagram of filter fans

#### Caution!

Dust can enter the control cabinet if it is not sealed properly when using a fan-intake! This type of air flow should be avoided.

#### Warning!

Make sure that only well-sealed control cabinets are used. Otherwise, contaminated ambient air could permeate the control cabinet.

### 5.3 Using air/air heat exchangers

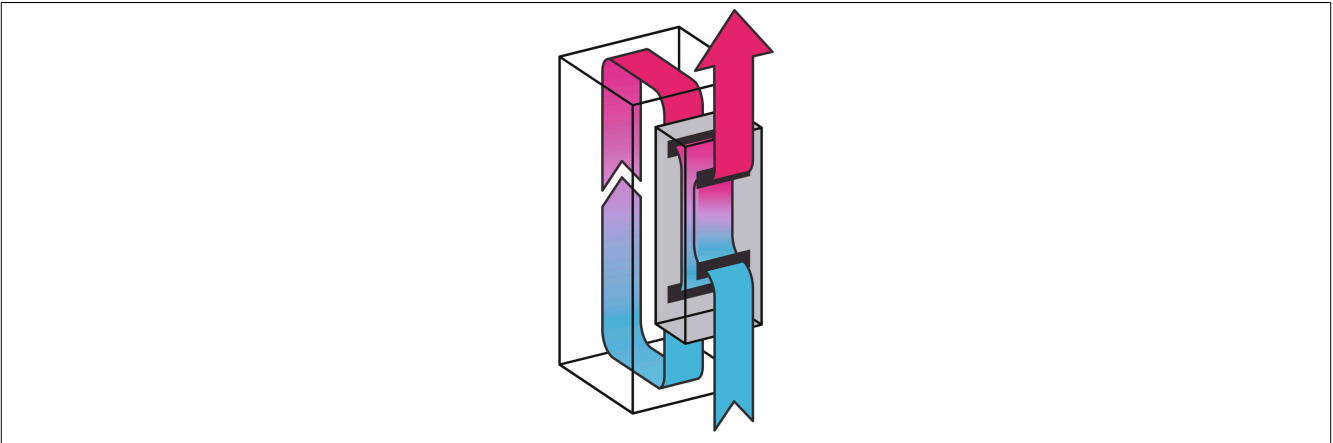


Figure 64: Function diagram of air/air heat exchangers

#### Caution!

An even circulation of air must be ensured in the control cabinet. Air intake openings and outlets for the inner circulation of the air/air heat exchanger must not be covered because this would prevent sufficient air circulation in the control cabinet.

It is recommended to allow for sufficient space (>200 mm) in front of the air intakes and outlets.

#### Caution!

If any modules or electronic components are used in the control cabinet that use their own fans, make sure that the direction of air flow does not go against the cooling system's flow of cool air. This could create air pockets that would prevent sufficient cooling in the control cabinet.

#### Warning!

Make sure that only well-sealed control cabinets are used. Otherwise, contaminated ambient air could permeate the control cabinet.

Installing air/air heat exchangers behind mounting plates should generally be avoided. If this is necessary, however, then corresponding air shields must be used. Air intake openings and outlets must also be added to the mounting plate.

## 5.4 Using air/water heat exchangers

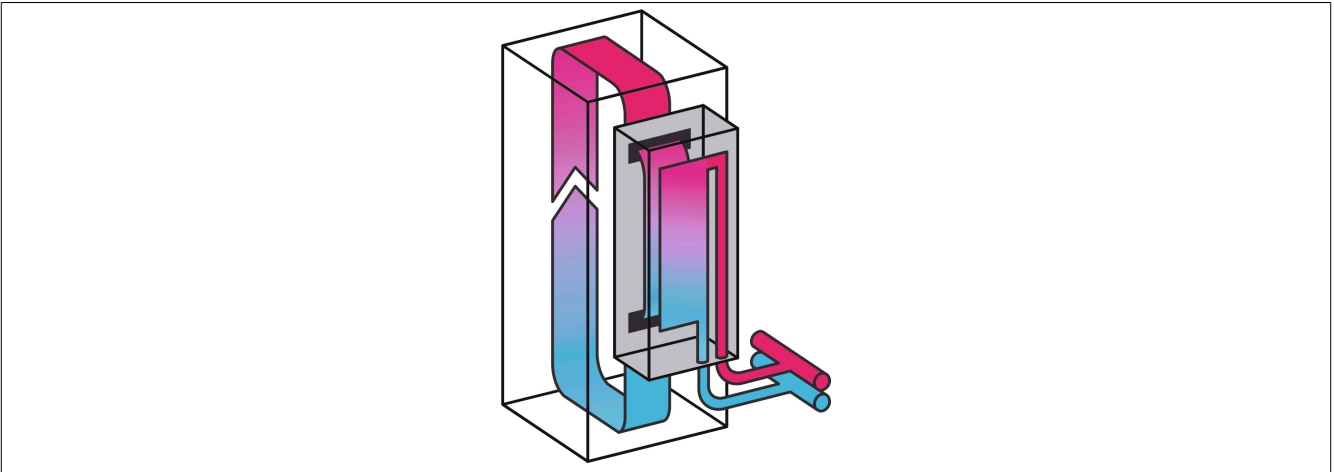


Figure 65: Function diagram of air/water heat exchangers

### Caution!

An even circulation of air must be ensured in the control cabinet. Air intake openings and outlets for the inner circulation of the air/water heat exchanger must not be covered because this would prevent sufficient air circulation in the control cabinet.

It is recommended to allow for sufficient space (>200 mm) in front of the air intakes and outlets.

### Caution!

If any modules or electronic components are used in the control cabinet that use their own fans, make sure that the direction of air flow does not go against the cooling system's flow of cool air. This could create air pockets that would prevent sufficient cooling in the control cabinet.

### Warning!

Make sure that only well-sealed control cabinets are used. Otherwise, contaminated ambient air could permeate the control cabinet.

Installing air/water heat exchangers behind mounting plates should generally be avoided. If this is necessary, however, then corresponding air shields must be used. Air intake openings and outlets must also be added to the mounting plate.

## 5.5 Using cooling units

### 5.5.1 General information

#### Caution!

Incorrect installation of cooling units may cause condensation which can damage the ACOPOS servo drives installed there!

Condensation can enter the ACOPOS servo drives with the cooled air flow!

#### Warning!

Make sure that only well-sealed control cabinets are used. Otherwise, ambient air could penetrate and cause condensation.

During operation with the control cabinet doors open (e.g. service), the ACOPOS servo drives are not allowed to be cooler than the air in the control cabinet at any time after the doors are closed.

To keep the temperature of the ACOPOS servo drives and the control cabinet at the same level, the cooling unit must remain in operation even when the system is switched off.

Cooling units must be installed in a way that prevents condensation from dripping into the ACOPOS servo drives. This should be considered when selecting the control cabinet (special construction for use of cooling units on top of the control cabinet).

Also make sure that condensed water that forms in the cooling unit fan when it is switched off cannot sprinkle into the ACOPOS servo drives.

Make sure the temperature setting of the cooling unit is correct! Only set the control cabinet's internal temperature as low as is necessary.

Be sure to follow the installation guidelines for the cooling unit provided in its operating manual!

### 5.5.2 Placing a cooling unit on top of the control cabinet

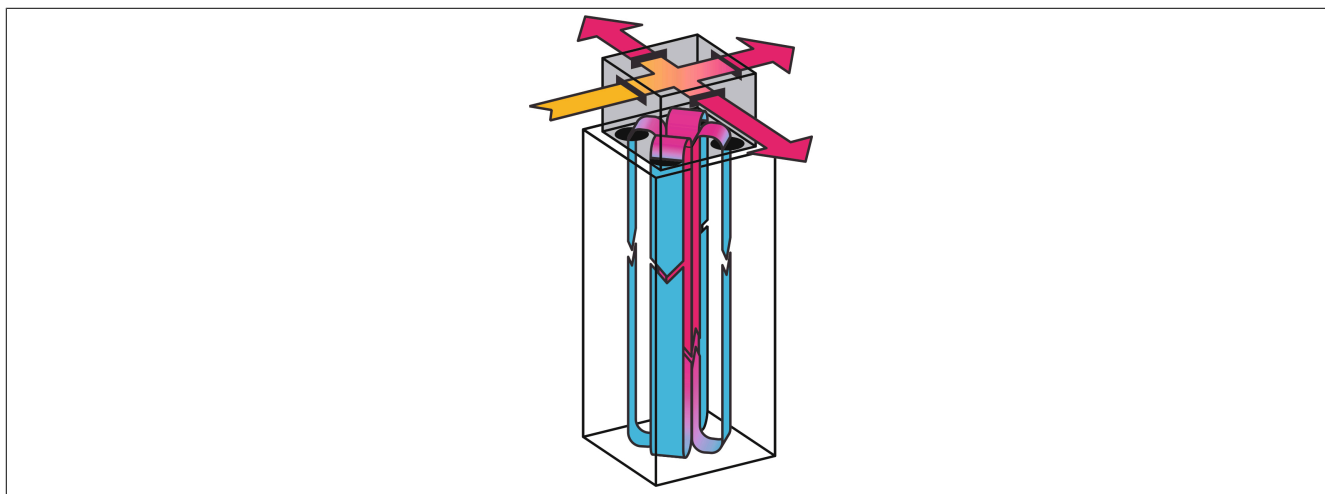


Figure 66: Placing a cooling unit on top of the control cabinet

#### Caution!

Targeted air flow must be ensured when arranging cooling units on the top of the control cabinet! The flow of cool air must be directed through air channel systems at the lowest possible point in the control cabinet (see image above).

#### Caution!

Make sure that the flow of cool air in the cooling system is not directed against the air flow from the fans in the ACOPOS servo drive. This could create air pockets that would prevent sufficient cooling of ACOPOS servo drives.

Condensation must be directed off the cooling unit according to manufacturer specifications so that it does not end up in the ACOPOS servo drives.

### 5.5.3 Placing a cooling unit on the front of the control cabinet

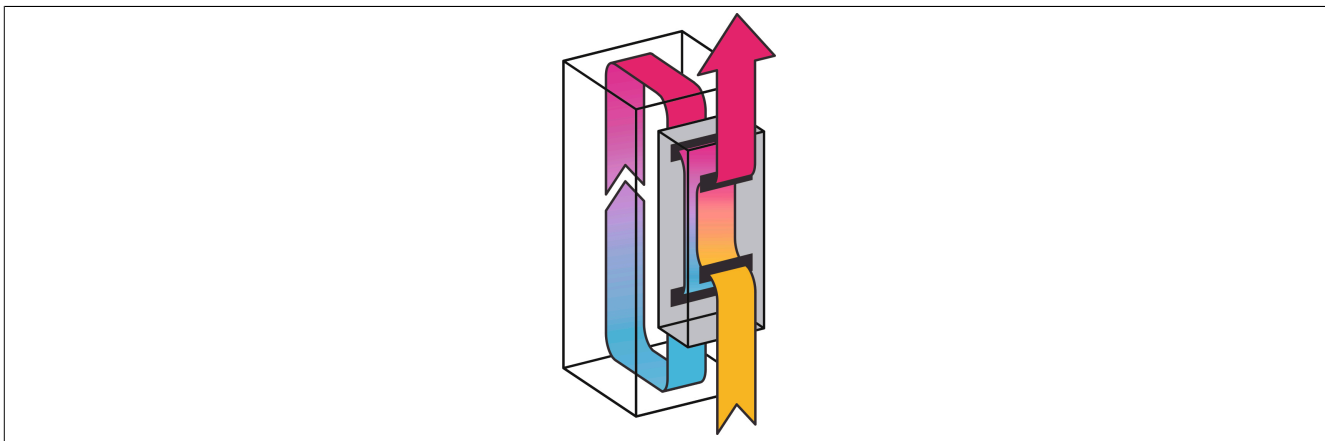


Figure 67: Placing a cooling unit on the front of the control cabinet

#### **Caution!**

The flow of cool air from the cooling unit must be directed through air channel systems at the lowest possible point in the control cabinet (see image above).

#### **Caution!**

Make sure that the flow of cool air in the cooling system is not directed against the air flow from the fans in the ACOPOS servo drive. This could create air pockets that would prevent sufficient cooling of ACOPOS servo drives.

Condensation must be directed off the cooling unit according to manufacturer specifications so that it does not end up in the ACOPOS servo drives.

## 6 Motor cables

### 6.1 Assembly example (module-side) of a 1.5 mm<sup>2</sup> motor cable

1. Shorten the motor cable to the required length.
2. Strip the motor cable on the module end of the cable (make sure not to damage the entire shield mesh).

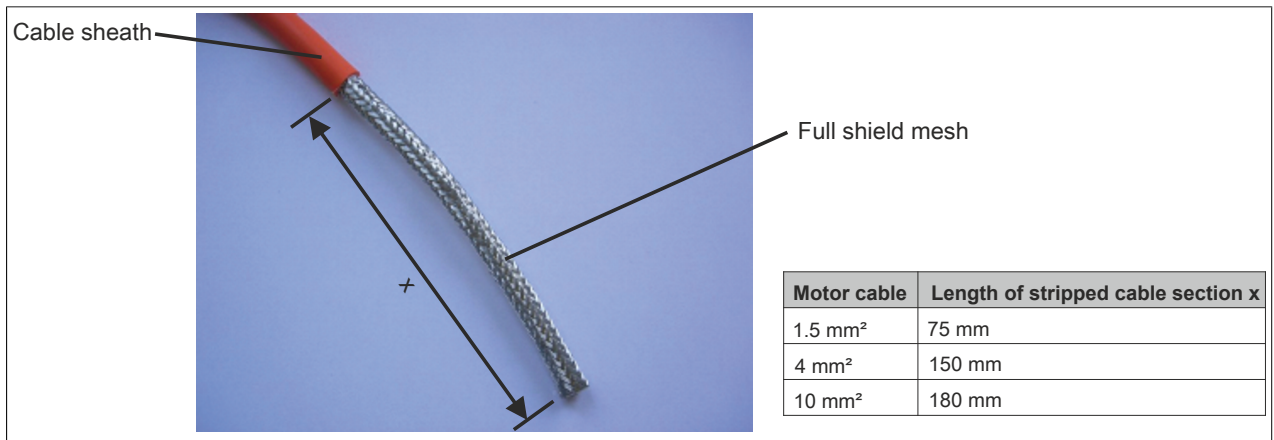


Figure 68: Stripped cable end

3. Pull the entire shield back over the cable sheath and cut off the stranding elements

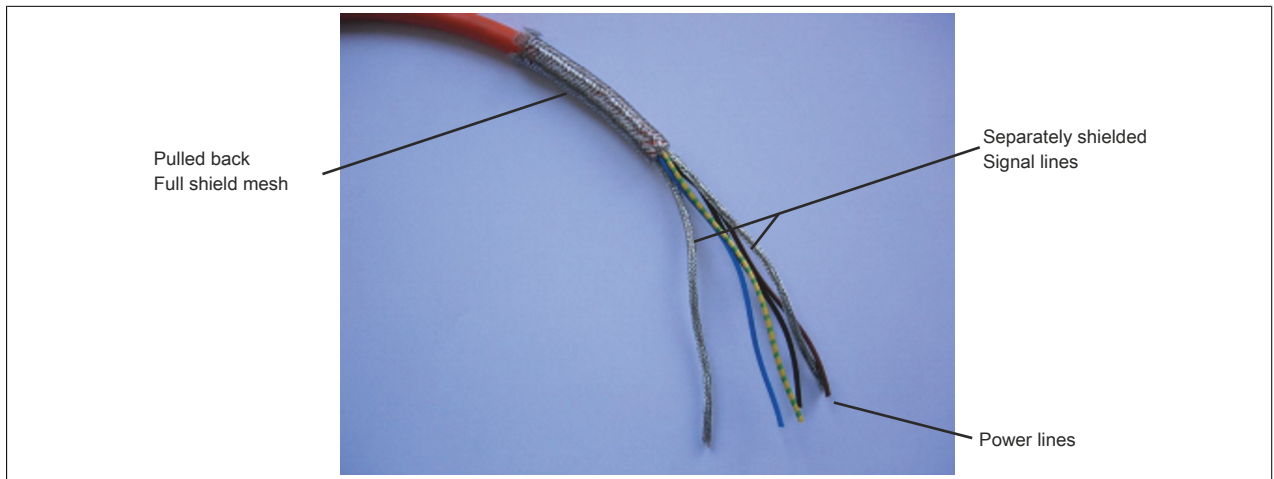


Figure 69: Cable end with shielding mesh pulled back

4. Pull the separately shielded signal lines (2x 2 lines) from the shielding mesh.

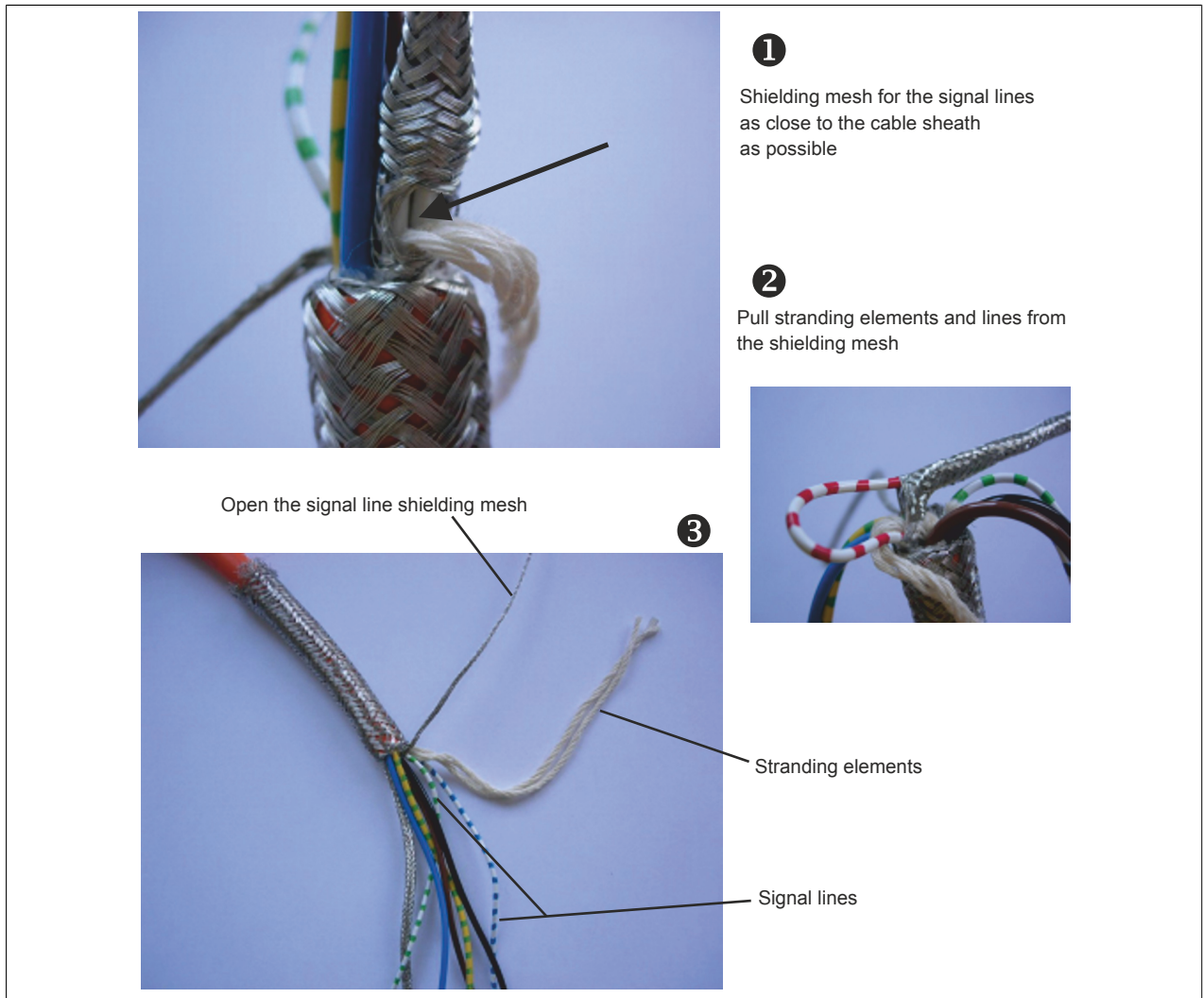


Figure 70: Pulling out the separately shielded signal lines

5. Cut the stranding elements of the separately shielded line.

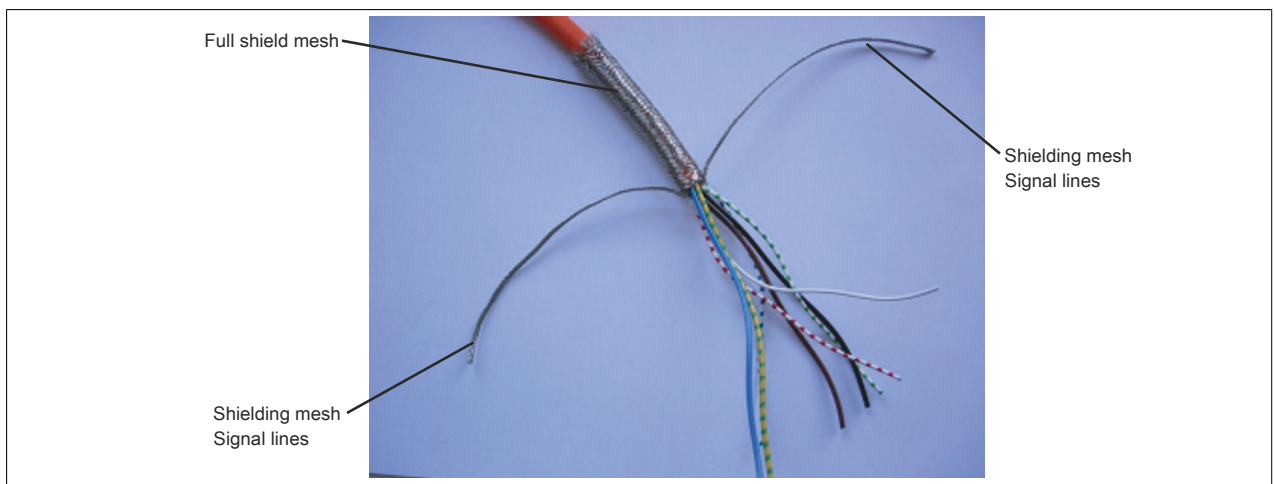


Figure 71: Cable end without stranding elements

- Shorten the shielding mesh to a length of approximately 40 mm and pull the signal line's shielding mesh over the cable sheath.

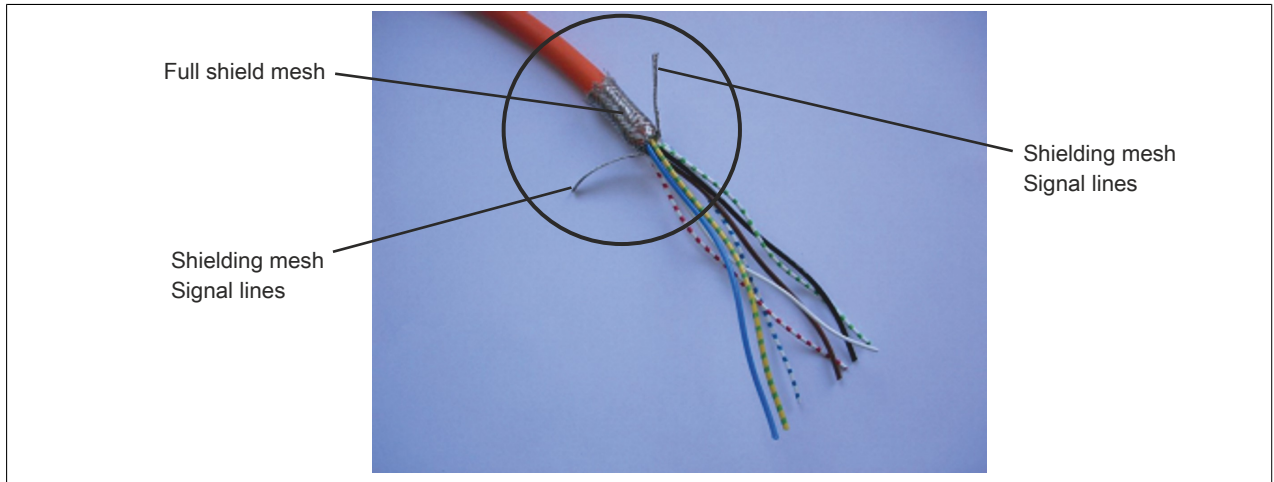


Figure 72: Cable ends with shortened shielding mesh

- Attach all shielding mesh to the cable sheath using heat shrink tubing (approx. 20 mm long), leaving some of the shielding mesh free.

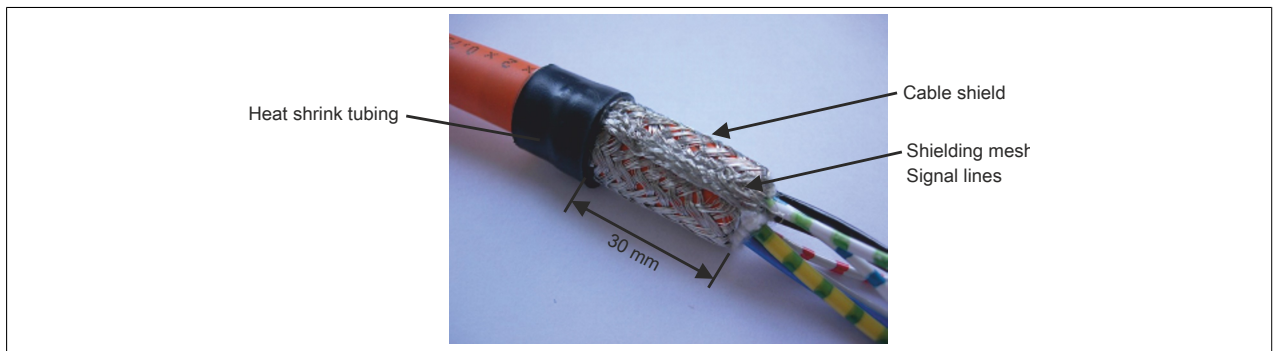


Figure 73: Attaching the shielding mesh

- Strip the wire ends and attach wire end sleeves.

Motor cable	Stripped lengths	
	Power lines	Signal lines
1.5 mm <sup>2</sup>	10 mm	8 mm
4 mm <sup>2</sup>	12 mm	8 mm
10 mm <sup>2</sup>	18 mm	8 mm

Motor cable	Wire end sleeves	
	Power lines	Signal lines
1.5 mm <sup>2</sup>	1.5 mm <sup>2</sup>	0.75 mm <sup>2</sup>
4 mm <sup>2</sup>	4 mm <sup>2</sup>	1 mm <sup>2</sup>
10 mm <sup>2</sup>	10 mm <sup>2</sup>	1.5 mm <sup>2</sup>

Figure 74: Wire ends with wire end sleeves



# Chapter 4 • Dimensioning

## 1 Power mains connection

### 1.1 General information

#### 1.1.1 Mains configurations

The power mains connection is made using terminals X3 / L1, L2, L3 and PE. ACOPOS servo drives can be directly connected to TT and TN power mains (these are three-phase systems with grounded neutral).

When using ungrounded IT power mains (three-phase systems without grounded neutral or with an impedance grounded neutral) or TN-S power mains with grounded phase conductor and protective ground conductor, isolation transformers must be used. The secondary neutral must be grounded and connected to the ACOPOS protective ground conductor. In this way, it is possible to prevent overvoltages between external conductors and the ACOPOS housing. Three-phase isolation transformers with the corresponding input and output voltages and a vector group with secondary neutral can be used (e.g. 3x 400 V / 3x 400 V, Dyn5).

In the USA, TT and TN power mains are among the most common mains systems and are referred to as "Delta / Wye with grounded Wye neutral". IT power mains systems are also known as "systems with ungrounded secondary" and TN-S power mains with grounded phase conductor as "Delta / Delta with grounded leg".

#### **Danger!**

**ACOPOS servo drives are only allowed to be operated directly on grounded, three-phase industrial mains (TN, TT power mains). When servo drives are used in residential areas, shops or small businesses, additional filtering measures must be implemented by the user.**

#### **Danger!**

**Servo drives are not permitted to be operated directly on IT and TN-S mains with a grounded phase conductor and protective ground conductor!**

#### **Warning!**

**ACOPOS servo drives are suitable for power mains which can provide a maximum short circuit current (SCCR) of 10,000 A<sub>eff</sub> at a maximum of 528 V<sub>eff</sub>.**

#### **Warning!**

**The power mains short circuit capacity S<sub>k</sub> must be 10 times greater than the continuous power of the selected servo drive.**

### 1.1.2 Supply voltage range

The supply voltage range permitted for ACOPOS servo drives can be found in the following table:

	8V1010.5xx-2 8V1016.5xx-2	8V1010.0xx-2 8V1016.0xx-2	8V1022.0xx-2 8V1045.0xx-2 8V1090.0xx-2	8V1180.0xx-2 8V1320.0xx-2	8V1640.0xx-2 8V128M.0xx-2
Mains input voltage	3x 110 VAC to 230 VAC ±10% or 1x 110 VAC to 230 VAC ±10%		3x 400 VAC to 480 VAC ±10%		

Table 161: Supply voltage range for ACOPOS servo drives

Respective intermediate transformers must be used for other supply voltages. With grounded power mains, autotransformers can also be used to adjust the voltage. Neutral does not have to be connected for this type of transformer.

## Warning!

The apparent power from the transformer (intermediate transformer, autotransformer) must be at least 25% of the continuous power from the ACOPOS drives being used. Otherwise, parasitic leakage inductances can cause excessive heating of the transformer. In extreme cases, this can cause critical damage to the transformer!

### 1.1.3 Protective ground connection (PE)

The following information concerning the protective ground connection corresponds to EN 61800-5-1, Item 4.2.5.4 "Connection elements for the protective ground conductor" and must be observed.

#### Wire cross section

The wire cross section of the protective ground wire is oriented to the outer wires and must be selected according to the following table:

Wire cross section for outer wire A [mm <sup>2</sup> ]	Minimum wire cross section for protective ground connection APE [mm <sup>2</sup> ] <sup>1)</sup>
A ≤ 16	A
16 < A ≤ 35	16
35 < A	A / 2

Table 162: Selection of the protective ground wire cross section

1) Any protective ground conductor that is not part of a cable must have a minimum wire cross section of 4 mm<sup>2</sup>.

#### Increased discharge current

ACOPOS servo drives are devices with increased discharge current (larger than 3.5 mA AC or 10 mA DC). Therefore, a fixed (immobile) protective ground connection is required on the servo drives.

The following conditions must be fulfilled depending on the ACOPOS device being used:

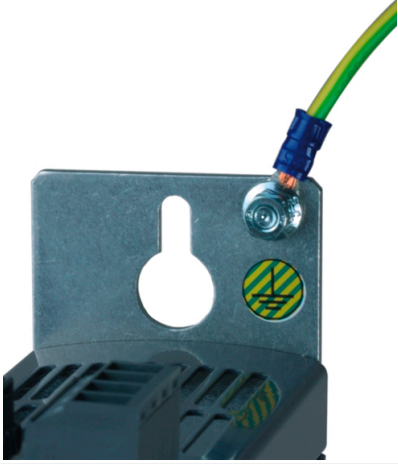


ACOPOS	Condition	Figure
1010 1016	In addition to the connection of the first protective ground conductor on terminal X3/PE, a second protective ground conductor with the same cross section must be connected on the designated terminal (M5 threaded bolt).	
1022 1045 1090	In addition to the connection of the first protective ground conductor on terminal X3/PE, a second protective ground conductor with the same cross section must be connected on the designated terminal (M5 threaded bolt).	
1180 1320	In addition to the connection of the first protective ground conductor on terminal X3/PE, a second protective ground conductor with the same cross section must be connected on the designated terminal (M5 threaded bolt).	
1640 128 M	The cross section of the protective ground conductor connected to terminal X3 / PE must be at least 10mm <sup>2</sup> Cu.	

Table 163: Protective ground conditions depending on the ACOPOS device

## 1.2 Dimensioning

In general, dimensioning the power mains, the overcurrent protection and (if necessary) the line contactors depends on the structure of the power mains connection.

ACOPOS servo drives can be connected individually (each drive has separate overcurrent protection and, if necessary, a separate line contactor) or together in groups.

### 1.2.1 Individual ACOPOS power mains connections

The structure of an individual power mains connection with line contactor and circuit breaker can be seen in the following diagram:

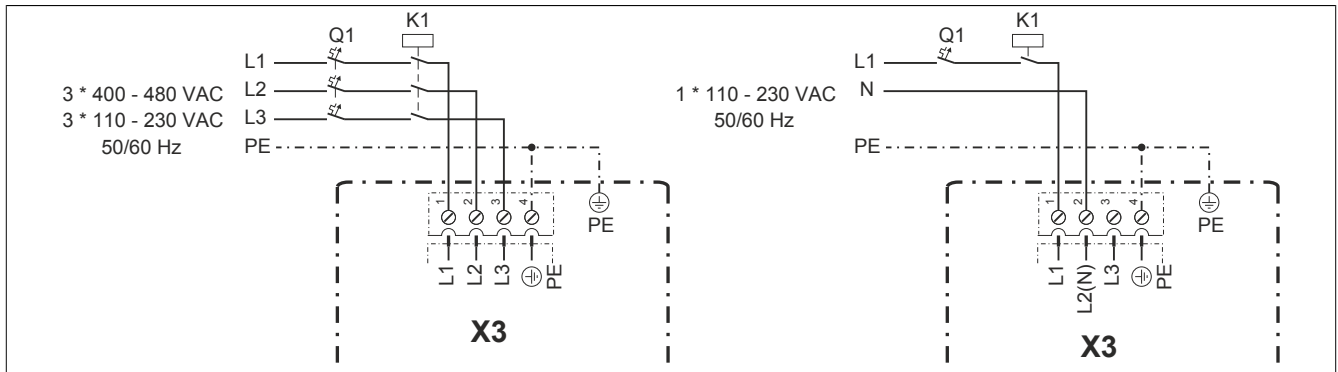


Figure 75: ACOPOS X3, individual power mains connection - Circuit diagram

### Dimensioning the power mains and overcurrent protection

#### Information:

When choosing a suitable fuse, the user must also account for characteristics such as aging effects, temperature derating, overcurrent capacity and the definition of the rated current, which can vary by manufacturer and type. In addition, the fuse that is selected must also be able to handle application-specific characteristics (e.g. overcurrent that occurs in acceleration cycles).

The cross section of the power mains and the rated current for overcurrent protection should be determined based on the average current load to be expected.

The average current load to be expected can be calculated as follows:

$$I_{mains}[A] = \frac{P[VA]}{\sqrt{3} \cdot U_{mains}[V]}$$

The apparent power S can be estimated as follows: <sup>5)</sup>

$$S[VA] = M_{eff}[Nm] \cdot k \cdot \frac{2 \cdot \pi \cdot n_{avg}[min^{-1}]}{60}$$

The following estimate is valid for linear motors: <sup>6)</sup>

<sup>5)</sup> If information concerning load torque, inertia and friction are available, the effective torque or the effective power is calculated according to the following formulas:

$$M_{eff}[Nm] = \sqrt{\frac{1}{T_{cycle}[s]} \cdot \sum_1 M_i[Nm]^2 \cdot t_i[s]}$$

$$F_{eff}[N] = \sqrt{\frac{1}{T_{cycle}[s]} \cdot \sum_1 F_i[N]^2 \cdot t_i[s]}$$

To calculate  $n_{avg}$  or  $v_{avg}$ , information concerning the positioning cycle must be available.

$n_{avg}$  or  $v_{avg}$  is calculated using the following formulas:

$$n_{avg}[min^{-1}] = \frac{1}{T_{cycle}[s]} \cdot \sum_1 n_i[min^{-1}] \cdot t_i[s]$$

$$v_{avg}[m/s] = \frac{1}{T_{cycle}[s]} \cdot \sum_1 v_i[m/s] \cdot t_i[s]$$

If the values  $n_{avg}$  or  $v_{avg}$  become very low, this can cause imprecise results in some situations. In this case, you should contact B&R regarding the use of different calculation formulas or methods.

<sup>6)</sup> If information concerning load torque, inertia and friction are available, the effective torque or the effective power is calculated according to the following formulas:

$$M_{eff}[Nm] = \sqrt{\frac{1}{T_{cycle}[s]} \cdot \sum_1 M_i[Nm]^2 \cdot t_i[s]}$$

$$S[VA] = F_{eff}[N] \cdot k \cdot v_{avg}[m/s]$$

The constant k for each of the various ACOPOS servo drives can be taken from the following table:

Name	ACOPOS								
	1010	1016	1022	1045	1090	1180	1320	1640	128 M
Constant k	3		2.8	2.4		2.1	1.9	1.7	1.5

Table 164: Constant k

The cross section of the power mains and the rated current of the overcurrent protection used are chosen according to "Table 165: Maximum current load for PVC insulated three-phase cables or individual wires" on page 207 so that the maximum current load for the cable cross section selected is greater than or equal to the calculated current load.

$$I_Z \geq I_{mains}$$

The rated current of the overcurrent protection must be less than or equal to the maximum current load for the cable cross section selected (see "Table 165: Maximum current load for PVC insulated three-phase cables or individual wires" on page 207).

$$I_B \leq I_Z$$

The following table shows the maximum current load of PVC insulated three-phase cables (or three current-carrying wires) in accordance with IEC 60204-1 at 40°C ambient temperature <sup>7)</sup> and 70°C maximum wire temperature (maximum current load for installation type F and cross sections greater than 35 mm<sup>2</sup>; IEC 60364-5-523 is used for installation types B1 and B2).

Wire cross section [mm <sup>2</sup> ]	Maximum current load for the cable cross section $I_Z$ / rated current for the overcurrent protection $I_R$ [A] depending on the type of installation				
	Three individual wires in conduit or cable duct	Three-phase cable in conduit or cable duct	Three-phase cable on walls	Three-phase cable in a cable tray	Three individual wires in a cable tray
	B1	B2	C	E	E
1.5	13.5 / 13	12.2 / 10	15.2 / 13	16.1 / 16	---
2.5	18.3 / 16	16.5 / 16	21 / 20	22 / 20	---
4	25 / 25	23 / 20	28 / 25	30 / 25	---
6	32 / 32	29 / 25	36 / 32	37 / 32	---
10	44 / 32	40 / 32	50 / 50	52 / 50	---
16	60 / 50	53 / 50	66 / 63	70 / 63	---
25	77 / 63	67 / 63	84 / 80	88 / 80	96 / 80
35	97 / 80	83 / 80	104 / 100	114 / 100	119 / 100
50	117 / 100	103 / 100	123 / 100	123 / 100	145 / 125
70	149 / 125	130 / 125	155 / 125	155 / 125	188 / 160
95	180 / 160	156 / 125	192 / 160	192 / 160	230 / 200

Table 165: Maximum current load for PVC insulated three-phase cables or individual wires

When determining the cross section for the power mains, make sure that the cross section selected is within the range that can be used with the X3 power mains terminal (see "Overview of clampable cross sections" on page 245).

Overcurrent protection in the form of a circuit breaker or a fuse is required. Circuit breakers (time lag) with type C tripping characteristics (in accordance with IEC 60898) or fuses (time lag) with type gG tripping characteristics (in accordance with IEC 60269-1) must be used. <sup>8)</sup>

$$6) F_{eff}[N] = \sqrt{\frac{1}{T_{cycle}[s]} \sum_1 F_i[N]^2 \cdot t_i[s]}$$

To calculate  $n_{avg}$  or  $v_{avg}$ , information concerning the positioning cycle must be available.

$n_{avg}$  or  $v_{avg}$  is calculated using the following formulas:

$$n_{avg}[\text{min}^{-1}] = \frac{1}{T_{cycle}[s]} \sum_1 n_i[\text{min}^{-1}] \cdot t_i[s]$$

$$v_{avg}[m/s] = \frac{1}{T_{cycle}[s]} \sum_1 v_i[m/s] \cdot t_i[s]$$

If the values  $n_{avg}$  or  $v_{avg}$  become very low, this can cause imprecise results in some situations. In this case, you should contact B&R regarding the use of different calculation formulas or methods.

<sup>7)</sup> The maximum current load value in IEC 60204-1 is for an ambient temperature of 40°C. This reference temperature is 30°C in IEC 60364-5-523. The values in table "Maximum current load for PVC insulated three-phase cables or individual wires" from IEC 60364-5-523 are also converted for use at 40°C with the factor  $k_{temp} = 0.87$  specified in the standard.

The specified maximum current load does not take a reduction factor for groups of cables and individual wires into consideration. If necessary, this must be taken from the corresponding standards and included in the calculation.

<sup>8)</sup> Circuit breakers are available on the market with rated currents from 6 A to 63 A. Outside of this range, fuses must be used.

**North America:**

Class J fuses according to UL Standard 248-8 can be used (for example fuses of type AJTxx from Ferraz Shawmut ([www.ferrazshawmut.com](http://www.ferrazshawmut.com)) or typeLPJ-xxSP from Bussmann ([www.bussmann.com](http://www.bussmann.com)), where xx is the nominal current for the respective fuse).

As an alternative, class CC fuses according to UL Standard 248-4 can be used (for example fuses of type LP-CC-xx from Bussmann ([www.bussmann.com](http://www.bussmann.com)), where xx is the rated current of the respective fuse; fuses of type LP-CC-xx are available up to a nominal current of 30 A).

The fuse must have the following tripping characteristics:

Minimum tripping time [s]	Rated current for the fuse at an average expected current load of			
	12 ... 35 A	50 ... 80 A	100 ... 125 A	160 A
0.2	Approx. $5.1 \cdot I_B$	Approx. $4.5 \cdot I_B$	Approx. $3.6 \cdot I_B$	Approx. $4.0 \cdot I_B$
4	Approx. $3.7 \cdot I_B$	Approx. $3.3 \cdot I_B$	Approx. $2.8 \cdot I_B$	Approx. $3.2 \cdot I_B$
10	Approx. $2.9 \cdot I_B$	Approx. $2.5 \cdot I_B$	Approx. $2.0 \cdot I_B$	Approx. $2.3 \cdot I_B$
240	Approx. $1.7 \cdot I_B$	Approx. $1.7 \cdot I_B$	Approx. $1.6 \cdot I_B$	Approx. $1.8 \cdot I_B$

Table 166: Tripping characteristics of the fuse for the power mains connection

**Dimensioning the line contactor**

The rated current of the line contactor is oriented to the overcurrent protection for the power mains connection. The line contactor is set up so that nominal operating current specified by the manufacturer of the line contactor for category AC-1 in accordance with EN 60947-4-1 is approximately 1 times the rated current of the overcurrent protection.

**Warning!**

**ACOPOS servo drive DC bus circuits that are connected separately to the power mains via line connectors must not be interconnected!**

**Connecting a line choke and a line contactor before each individual servo drive in a group is not permitted. If, in this case, the DC bus circuits of the individual servo drives are interconnected, the rectifiers in the servo drives can be overloaded and possibly destroyed.**

## 1.2.2 Implementing ACOPOS power mains connections for drive groups

The structure of the power mains connection for a drive group with line contactor and circuit breaker can be seen in the following diagram:

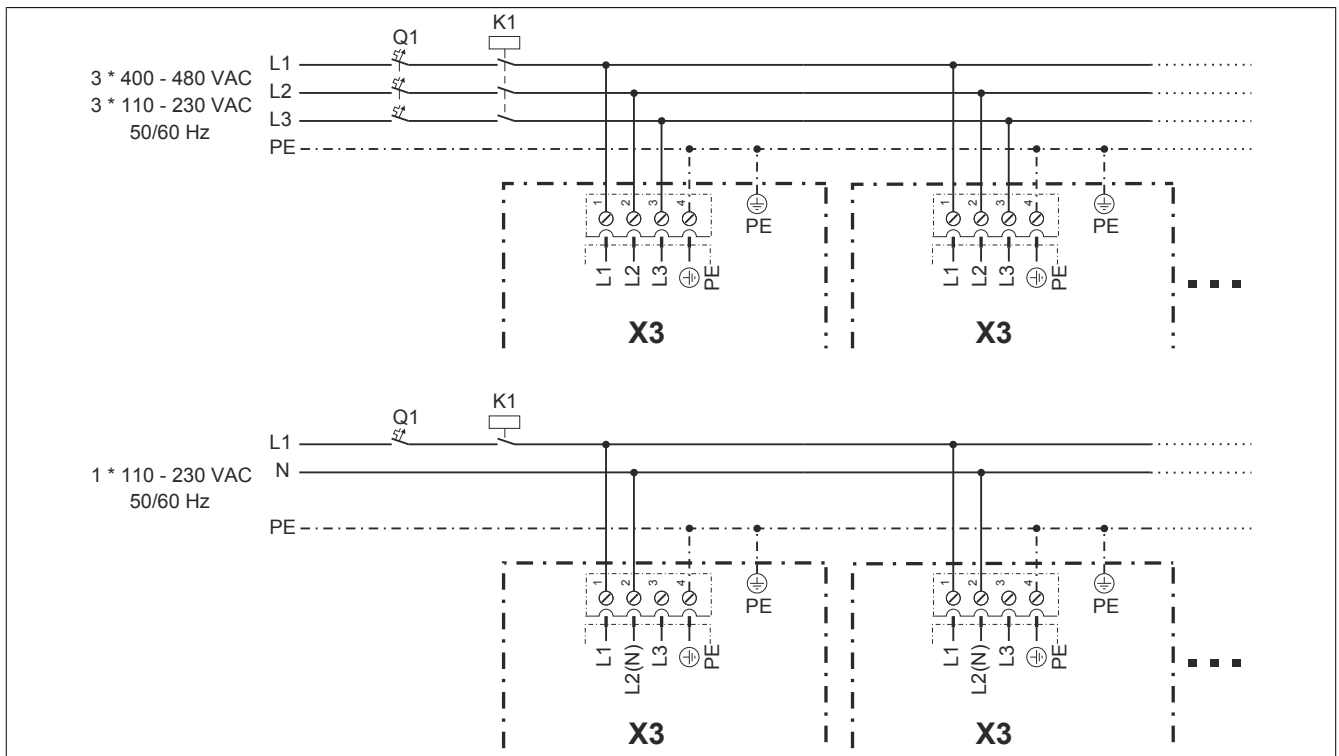


Figure 76: ACOPOS X3, power mains connection for a drive group - Circuit diagram

### Using a mains choke

The optional use of a mains choke for drive groups can reduce the total harmonic distortion (THD) and the effective value for the mains current while increasing the total power factor (TPF). The nominal current for the line choke must be equal to the nominal current of the fuse that is protecting the drive group. In this way, the line choke is protected against overload by the fuse.

A line choke connection diagram is shown in the following image:

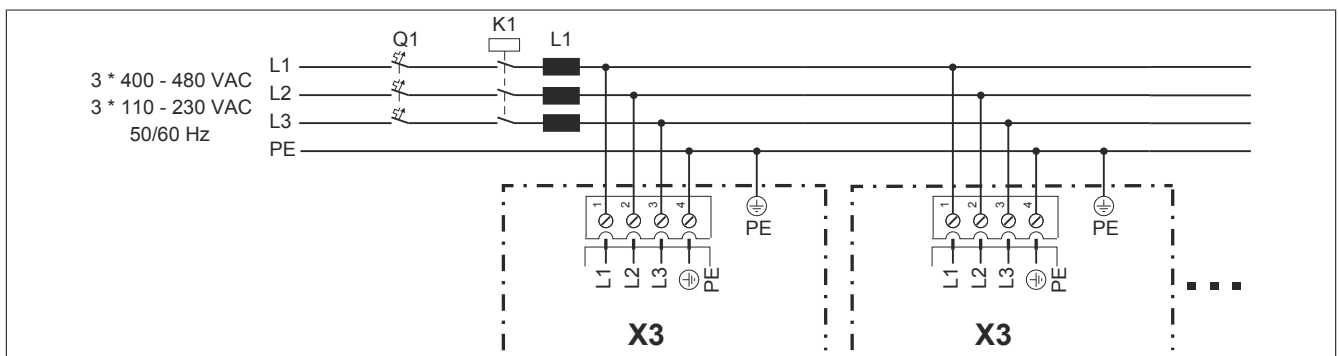


Figure 77: ACOPOS X3, power mains connection for a drive group with optional line choke - Circuit diagram

### Warning!

**For multi-axis configurations, only one line choke and one line contactor are permitted to be connected before the entire ACOPOS servo drive group (see "Figure 77: ACOPOS X3, power mains connection for a drive group with optional line choke - Circuit diagram" on page 209)!**

Model number	Short description
8IOCT004.000-1	ACPI line choke 3-phase 4 A
8IOCT010.000-1	ACPI line choke 3-phase 10 A
8IOCT016.000-1	ACPI line choke 3-phase 16 A
8IOCT030.000-1	ACPI line choke 3-phase 30 A
8IOCT060.000-1	ACPI line choke 3-phase 60 A
8IOCT100.000-1	ACPI line choke 3-phase 100 A
8IOCT184.000-1	ACPI line choke 3-phase 184 A
8IOCT222.000-1	ACPI line choke 3-phase 222 A
8IOCT230.000-1	ACPI line choke 3-phase 230 A

Table 167: Model numbers for the line chokes available from B&amp;R

## Dimensioning the power mains and fuse

### Information:

**When choosing a suitable fuse, the user must also account for properties such as aging effects, temperature derating, overcurrent capacity and the definition of the rated current, which can vary by manufacturer and type. In addition, the fuse that is selected must also be able to handle application-specific characteristics (e.g. overcurrent that occurs in acceleration cycles).**

The cross section of the distribution point and all power mains connections are chosen according to "Table 165: Maximum current load for PVC insulated three-phase cables or individual wires " on page 207 so that the maximum current load for the cable cross section selected<sup>9)</sup> is greater than or equal to the sum of the calculated mains current.

$$I_Z \geq \sum I_{mains}$$

The rated current of the overcurrent protection must be less than or equal to the maximum current load for the cable cross section selected (see "Table 165: Maximum current load for PVC insulated three-phase cables or individual wires " on page 207).

$$I_B \leq I_Z$$

### Dimensioning the line contactor

The rated current of a common line contactor is oriented to the overcurrent protection for the power mains connection. The line contactor is set up so that nominal operating current specified by the manufacturer of the line contactor for category AC-1 is approximately 1.3 times the rated current of the overcurrent protection.

<sup>9)</sup> When determining a common cross section for several drives (especially with different sized ACOPOS modules), make sure that the cross section selected is within the range that can be used with the power mains terminals (see "Overview of clampable cross sections" on page 245).

### 1.3 Fault current protection

Fault current protection (RCD - residual current-operated protective device) can be used with ACOPOS servo drives. The following points must be noted, however:

ACOPOS servo drives have a power rectifier. If a short circuit to the frame occurs, a flat DC fault current can be created which prevents an AC current or pulse current sensitive RCD (type A or AC) from being activated, therefore canceling the protective function for all connected devices.

#### Danger!

**If used for protection during direct or indirect contact of the fault current protection (RCD), only a Type B RCD (AC-DC sensitive, in accordance with IEC 60755) can be used for the ACOPOS power mains connection. Otherwise, additional protective measures must be used, such as neutralization or isolation from the power mains using an isolation transformer.**

#### 1.3.1 Rated fault current

On ACOPOS servo drives, fault current protection with a rated fault current<sup>10)</sup> of  $\geq 100$  mA can be used. However, errors can occur:

- When connecting servo drives to the power mains (short-term single-phase or two-phase operation because of contact chatter on the line contactor).
- Because of high frequency discharge currents occurring during operation when using long motor cables.
- Because of an extreme unbalance factor for the three-phase system.

#### 1.3.2 Estimating the discharge current

Depending on the connection of the ACOPOS servo drive, different discharge currents flow to ground on the protective ground conductor (PE):

Single-phase or two-phase operation (as intermediate state when switching on the line contactor):

$$I_A[A] = \frac{U_{mains}[V] \cdot 2 \cdot \pi \cdot f_{mains}[Hz] \cdot C_A[F]}{\sqrt{3}}$$

Single-phase operation with neutral line:

$$I_A[A] = \frac{U_{mains}[V] \cdot 2 \cdot \pi \cdot f_{mains}[Hz] \cdot C_A[F]}{2 \cdot \sqrt{3}}$$

The discharge capacitance  $C_A$  of the various ACOPOS servo drives can be taken from the following table:

Name	ACOPOS								
	1010.0xx-2 1016.0xx-2	1010.5xx-2 1016.5xx-2	1022.0xx-2	1045.0xx-2	1090.0xx-2	1180.0xx-2	1320.0xx-2	1640.0xx-2	128M.0xx-2
Discharge capacitance $C_A$	550 nF	330 nF	660 nF			3.1 $\mu$ F		5.4 $\mu$ F	

Table 168: Discharge capacitance  $C_A$

#### 1.3.3 Manufacturer used

For example, the AC-DC sensitive, 4-pole fault current protective device F 804 from ABB (fault current: 300 mA; nominal current: 63 A) can be used. Using this fault current protective device, approximately 5 ACOPOS 1022 (or 1045, 1090) can be connected in parallel.

<sup>10)</sup> The rated fault current listed by the manufacturer are maximum values that will definitely trip the protective device. Normally, the protective device is tripped at approximately 60% of the rated fault current.

## 2 DC bus

### 2.1 General information

With ACOPOS servo drives, it is possible to connect several servo drives via the DC bus. This connection allows compensation of braking and drive energy of several axes or the distribution of braking energy to several braking resistors.

The connection is made using terminals X2 / +DC and -DC. The structure of the DC bus connections can be seen in the following diagram:

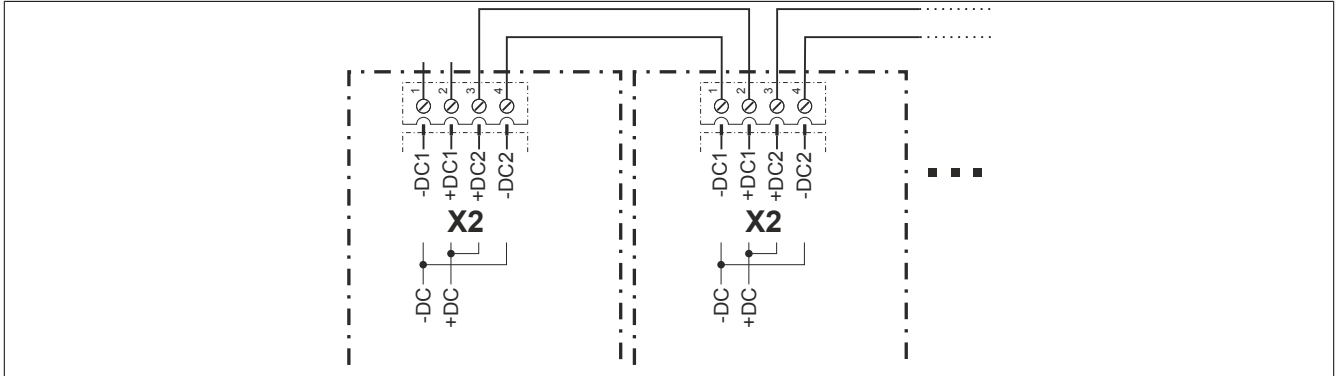


Figure 78: ACOPOS X2 DC bus connections - Circuit diagram

### Caution!

To prevent excessively high discharge currents from flowing over the individual servo drives, make sure that smaller servo drives are not connected between two larger servo drives.

### Warning!

For multi-axis configurations, only one line choke and one line contactor are permitted to be connected before the entire ACOPOS servo drive group (see "Figure 77: ACOPOS X3, power mains connection for a drive group with optional line choke - Circuit diagram" on page 209)!

### Warning!

Only DC bus circuits of ACOPOS servo drives with the same supply voltage range are permitted to be connected in a group ("Table 161: Supply voltage range for ACOPOS servo drives" on page 204).

Therefore, the DC bus circuits of ACOPOS servo drives 8Vxxxx.5xx-2 and 8Vxxxx.0xx-2 are not allowed to be linked! For this reason, the X2 plugs for ACOPOS servo drives 8Vxxxx.5xx-2 and 8Vxxxx.0xx-2 are keyed differently.

All ACOPOS servo drives 8Vxxxx.5xx-2 with a single-phase supply that should have their DC buses connected together must be connected to the same phase! If this is not done, the DC bus voltage increases to a level that is not permitted, causing the devices to be destroyed!

## 2.2 Wiring design

The DC bus connections on the ACOPOS servo drives do **not** have short circuit and ground fault protection and are not protected against reverse polarity. It is therefore very important that the DC bus connections be wired correctly.

### Caution!

**DC bus connections must be wired correctly (no short circuits, ground faults or reverse polarity).**

A suitable measure to ensure that the wiring is secure against short circuits and ground faults<sup>11)</sup> is the use of appropriate electrical lines. Special rubber-insulated wires with increased resistance to heat (90°C) of types

- NSGAÖÜ
- NSGAFÖÜ
- NSGAFCMÖÜ

with a nominal voltage  $U_0/U$  of at least 1.7/3 kV are considered to be secure against short circuits and ground faults in switchgear and distribution systems up to 1000 V<sup>12)</sup>.

## 2.3 Equal distribution of the applied power via the power rectifiers

When creating a DC bus connection between several servo drives, it is possible that the parallel connection of the power rectifiers causes incorrect distribution of the applied power.

### Warning!

**Distribution of the supplied power that is not permitted can occur both during operation and when booting the ACOPOS servo drives!**

To prevent this undesired effect, appropriately dimensioned balancing resistors are integrated in the ACOPOS servo drives.

The following rules must be observed so that the effect of these balancing resistors is not canceled out:

- The length of the DC bus wiring is not allowed to exceed a total length of 3 m and must be within a single control cabinet.
- Dimensioning the cross section of the ACOPOS servo drive power mains must be done according to section "Individual ACOPOS power mains connections" on page 206.
- The cross section of the DC bus wiring<sup>13)</sup> on the respective ACOPOS servo drives must be less than or equal to the cross section of the servo drive power mains.
- The selected cross section must be within the clampable cross section range for the DC bus connection terminal X2 (see "Overview of clampable cross sections" on page 245).
- For multi-axis configurations, only one line choke may be connected before the entire ACOPOS servo drive group.

<sup>11)</sup> Wiring design e.g. according to DIN VDE 0100, Part 200 "Electrical systems for buildings - terms", Item A.7.6.

<sup>12)</sup> See e.g. DIN VDE 0298, Part 3 "Use of cables and insulated wires for high-voltage systems", Item 9.2.8.

<sup>13)</sup> The cross section of the individual segments of the DC bus wiring must be dimensioned for the thermal equivalent effective value of the respective compensation current. If information concerning the compensation current flow is available, the thermal equivalent effective value for the compensation current can be calculated as follows:

$$I_q[A] = \sqrt{\frac{1}{T_{\text{cycle}}[s]} \cdot \sum_1 I_i[A]^2 \cdot t_i[s]}$$

The cross section of the DC bus connection should then also be selected as described in "Overview of clampable cross sections" on page 245, so that the maximum current load of the cable cross section is greater than or equal to the thermal equivalent effective value of the compensation current ( $I_z \geq I_q$ ).

## 2.4 Equal distribution of the brake power on the braking resistors

The braking resistors integrated in ACOPOS servo drives as well as braking resistors that can be connected externally are controlled using a specially developed procedure. This guarantees that the brake power is optimally and equally distributed on the braking resistors when a DC bus connection is made between several units.

When using integrated braking resistors, additional configuration is not required.

When using external braking resistors, the corresponding parameters must be defined (see "Configuring brake resistor parameters" on page 227).

## 2.5 Connecting external DC bus power supplies

ACOPOS servo drives recognize a power failure and can immediately initiate active braking of the motor. The brake energy generated when braking is returned to the DC bus, and the DC bus power supply can use it to create the 24 VDC supply voltage. In this way, the ACOPOS servo drives as well as encoders, sensors and possible safety circuit can be supplied with 24 VDC while braking. <sup>14)</sup>

An external DC bus power supply must be used for ACOPOS servo drives 8V1010 to 8V1090. A DC bus power supply is integrated in ACOPOS servo drives 8V1180 to 8V128M. <sup>15)</sup>

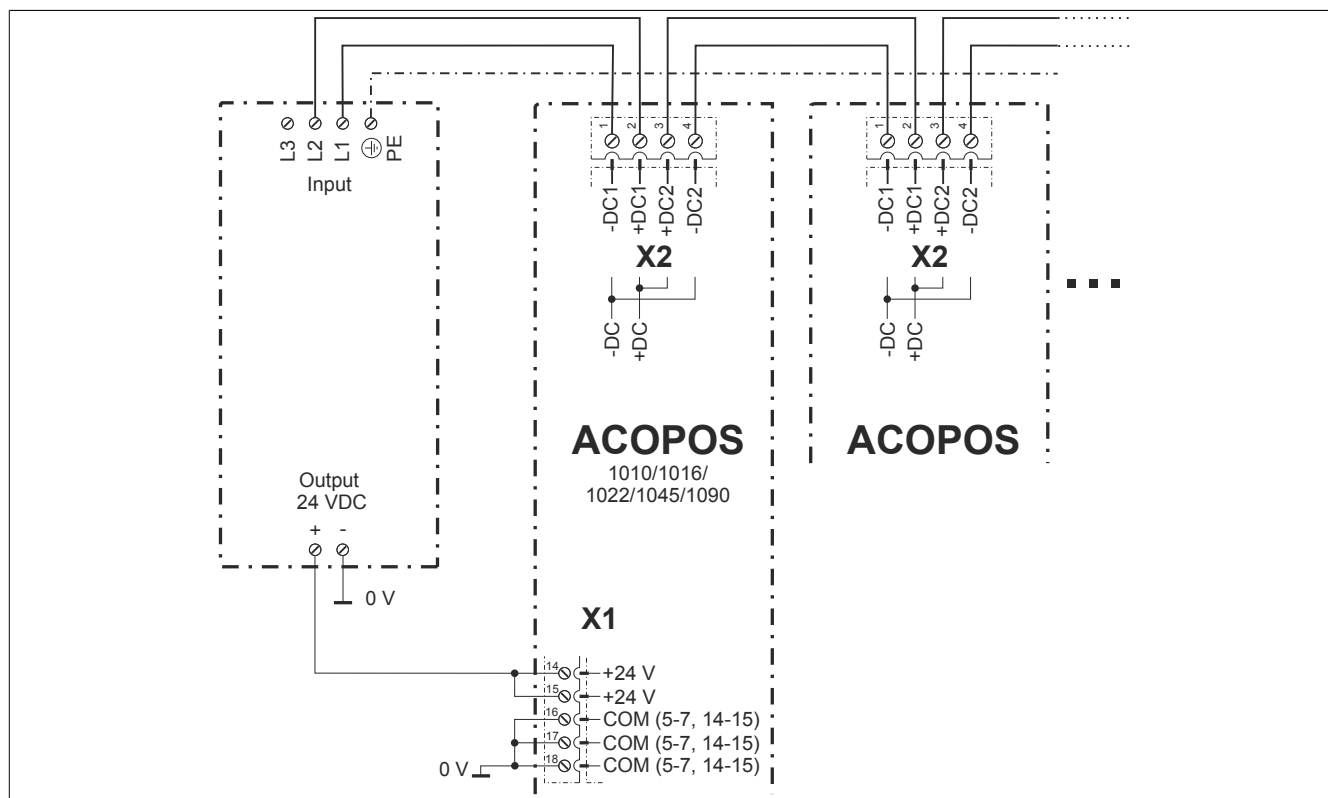


Figure 79: DC bus power supply for ACOPOS servo drives

<sup>14)</sup> IMPORTANT: In some applications, there is not enough brake energy provided to guarantee that the 24 VDC supply voltage remains active until the system is stopped.

<sup>15)</sup> The SL20.310 DC bus power supply from PULS can be used ([www.pulspower.com](http://www.pulspower.com)).

### 3 Motor connection

On B&R motors, the power connections, the connections for the holding brake and the connections for the motor temperature sensor are all made using the same motor connector.

On the servo drive, the motor connection is made using terminals X5 / U, V, W and PE as well as terminals X4b / B+, B-, T+ and T-. This motor connection must be shielded appropriately (see "Electromagnetic compatibility of the installation " on page 239).

The design of the motor connection can be seen in the following diagram:

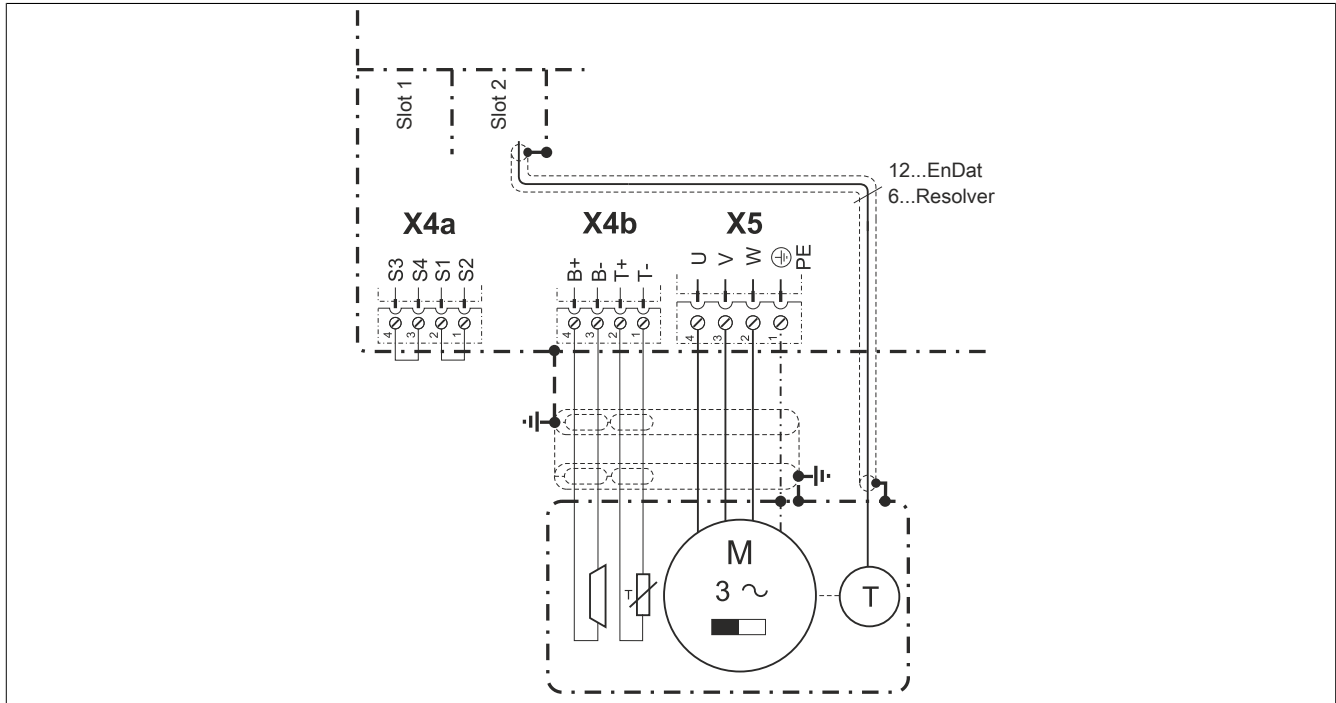


Figure 80: ACOPOS X4/X5 motor connections - Circuit diagram

The cross section of the motor cable must be dimensioned for the thermal equivalent effective value of the motor current. <sup>16)</sup>

The cross section of the motor cable is chosen for B&R motor cables according to the following table so that the maximum current load for the cable cross section selected is greater than or equal to the thermal equivalent effective value of the motor current:

$$I_Z \geq I_q$$

The following table shows the maximum current load for specially insulated three-phase cables in accordance with IEC 60364-5-523 at an ambient temperature of 40°C<sup>17)</sup> and 90°C maximum cable temperature.

Wire cross section [mm²]	Maximum current load on the wire I <sub>Z</sub> [A] depending on type of installation		
	Three-phase cable in conduit or cable duct	Three-phase cable on walls	Three-phase cable in a cable tray
	B2	C	E
0.75	11.5	13	13.5
1.5	17.8	20	20.9
4	31.9 <sup>1)</sup>	36.4 <sup>1)</sup>	38.2 <sup>1)</sup>
10	54.6	64.6	68.3
35	116.5	133.8	143.8

Table 169: Maximum current load for specially insulated three-phase cables

1) The plug pins on assembled B&R 8BCMxxx.1312A-0 motor cables can handle a max. load of 30 A.

When determining the cross section for the motor cable, make sure that the cross section selected is within the range that can be used with the X5 motor connection terminal (see section "Overview of clampable cross sections").

<sup>16)</sup> If information concerning load torque, inertia and friction is available, the thermal equivalent effective value for the motor current of the motor used can be calculated as follows:

$$I_q[A] = \sqrt{\frac{1}{T_{cycl}[s]} \sum_1 I_i[A]^2 \cdot t_i[s]}$$

<sup>17)</sup> The maximum current load value in IEC 60364-5-523 is for an ambient temperature of 30°C. The values in table "Maximum current load for PVC insulated three-phase cables or individual wires" are converted for use at 40°C ambient temperature using the factor k<sub>Temp</sub> = 0.91 given in the standard.

The specified maximum current load does not take a reduction factor for groups of cables and individual wires into consideration. If necessary, this must be taken from the corresponding standards and included in the calculation.

## 4 Braking resistors

### 4.1 General information

When braking servo motors, power is returned to the ACOPOS servo drive. This causes the capacitors in the DC bus to be charged to higher voltages. Starting with a DC bus voltage of approx. 800 V, the ACOPOS servo drive links the braking resistor to the DC bus using the brake chopper and converts the braking energy to heat.

For ACOPOS servo drives, braking resistors are integrated for this purpose or external braking resistors can be connected. The different features can be looked up in the following table:

Name	ACOPOS								
	1010	1016	1022	1045	1090	1180	1320	1640	128 M
Integrated brake chopper	Yes								
Internal braking resistor	Yes		Yes		Yes		Yes	Yes <sup>3)</sup>	Yes <sup>3)</sup>
Continuous power	130 W		130 W		200 W		400 W	200 W	240 W
Maximum power	2 kW <sup>1)</sup> 1.9 kW <sup>2)</sup>		3.5 kW		7 kW		14 kW	7 kW	8.5 kW
Connection of external braking resistor possible <sup>4)</sup>	No <sup>6)</sup>			Yes			Yes		
Continuous power ( $P_{BRmax}$ )	---			---			---		
Maximum power ( $P_{BRmax}$ )	---			---			---		
Minimum braking resistance ( $R_{minServo}$ )	---			---			---		
Rated current for the built-in fuse ( $I_{BRServo}$ ) <sup>5)</sup>	---			---			---		
				12 A (fast-acting)			30 A (fast-acting)		

Table 170: Braking resistors for ACOPOS servo drives

- 1) For 8V1010.0xx-2 and 8V1016.0xx-2.
- 2) For 8V1010.5xx-2 and 8V1016.5xx-2.
- 3) The braking resistor integrated in the ACOPOS servo drives 1640 and 128M is dimensioned so that it is possible to brake to a stop (in a typical drive situation).
- 4) The ACOPOS servo drives are designed so that either the integrated braking resistor or the external braking resistor can be activated. Braking with both braking resistors at the same time is not possible.  
Switching takes place using the software and is only possible during the ACOPOS servo drive initialization phase:

ParID 398: Setting for an internal / external braking resistor

0 ... Internal (default)

1 ... External

- 5) The fuses used must be fast-acting fuses  $\varnothing 10 \times 38$  mm for 600 VAC/VDC. For example, type KLKD0xx (xx is the rated current of the fuse in amperes e.g. KLKD030) from Littelfuse ([www.littelfuse.com](http://www.littelfuse.com)) can be used.
- 6) The braking resistors integrated in ACOPOS servo drives 1010, 1016, 1022, 1045 and 1090 are optimally dimensioned for the respective sizes.
- 7) Application-dependent (see "Table 172: Overview of braking resistor data - 8B0W" on page 220).

## 4.2 External braking resistor connections

External braking resistors are connected using the X6 / RB+, RB- and PE terminals. The structure of the external braking resistor connection can be seen in the following diagram:

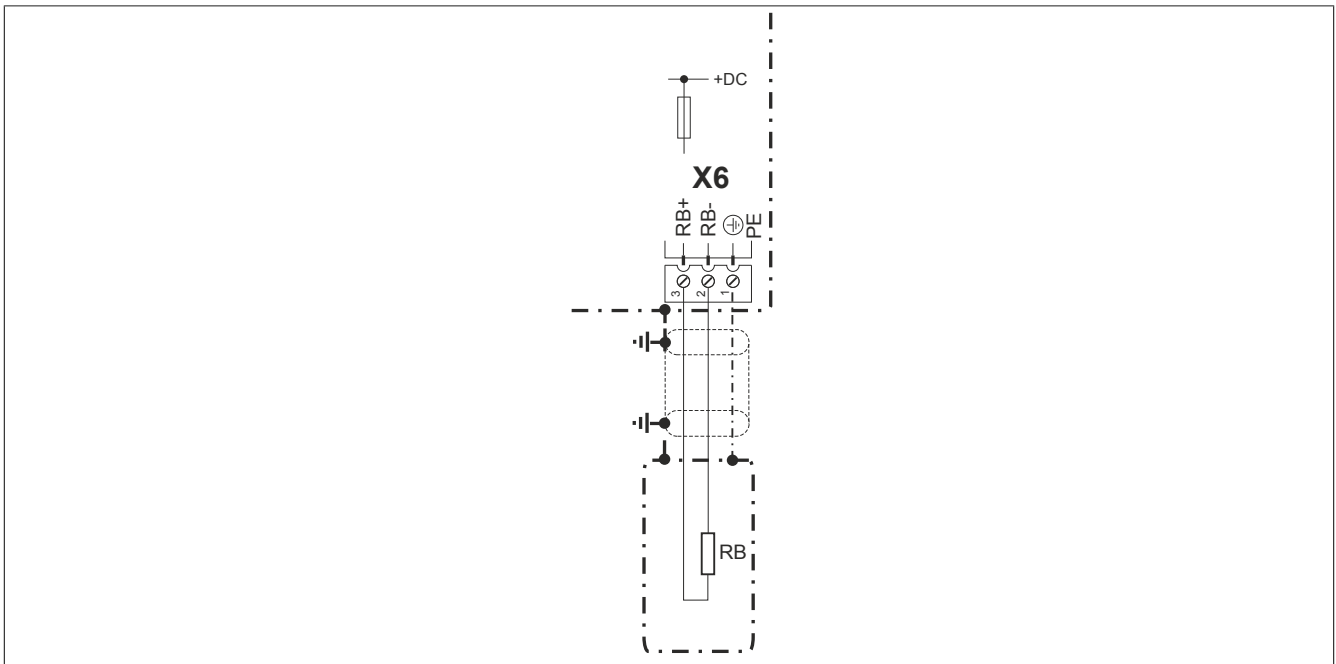


Figure 81: ACOPOS X6, external braking resistor on ACOPOS 1180/1320/1640/128M - Circuit diagram

When determining the cross section <sup>18)</sup> for wiring the external braking resistor, make sure that the cross section selected is within the range that can be used with braking resistor connection terminal X6 (see "Overview of clampable cross sections" on page 245).

<sup>18)</sup> The cross section of the braking resistor cable must be dimensioned for the thermal equivalent effective value of the respective brake current. If information concerning the the brake current flow is available, the thermal equivalent effective value for the brake current can be calculated as follows:

$$I_q[A] = \sqrt{\frac{1}{T_{cycle}[s]} \sum_1 I_i[A]^2 \cdot t_i[s]}$$

The cross section of the braking resistor connection should then be selected as described in "Table 165: Maximum current load for PVC insulated three-phase cables or individual wires" on page 207, so that the maximum current load of the cable cross section is greater than or equal to the thermal equivalent effective value of the brake current ( $I_z \geq I_q$ ).

### 4.2.1 Fuse protection

To protect the external braking resistor connection, a fuse is built into the bottom of ACOPOS servo drives. <sup>19)</sup>

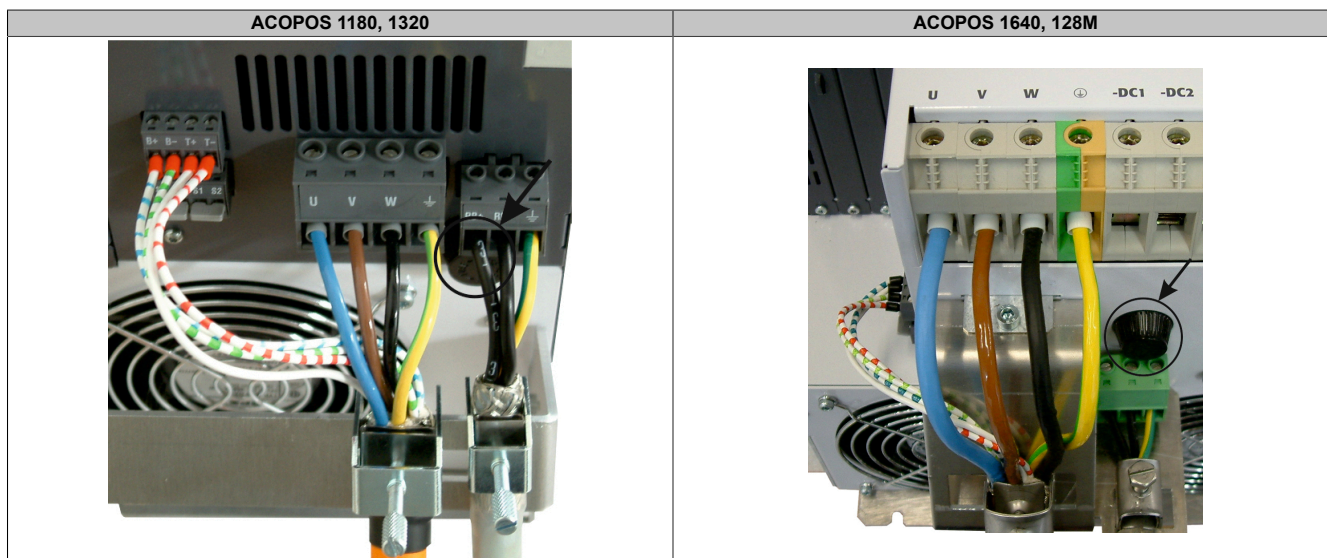


Table 171: The location where the fuse for the external braking resistor connection is installed

The relevant data for the fuses that are to be used can be found on the sticker close to the fuse holder.

<sup>19)</sup> External braking resistors can only be connected to ACOPOS 8V1180.0xx-2, 8V1320.0xx-2, 8V1640.0xx-2 and 8V128M.0xx-2 devices. The fuses used must be fast-acting fuses  $\varnothing 10 \times 38$  mm for 600 VAC/VDC. For example, type KLKD0xx (xx is the rated current of the fuse in amperes e.g. KLKD030) from Littelfuse ([www.littelfuse.com](http://www.littelfuse.com)) can be used.

### 4.3 Dimensioning the braking resistor

#### 4.3.1 Basis of the calculation

An external braking resistor can be dimensioned based on a movement and load profile (for each axis in the corresponding application):

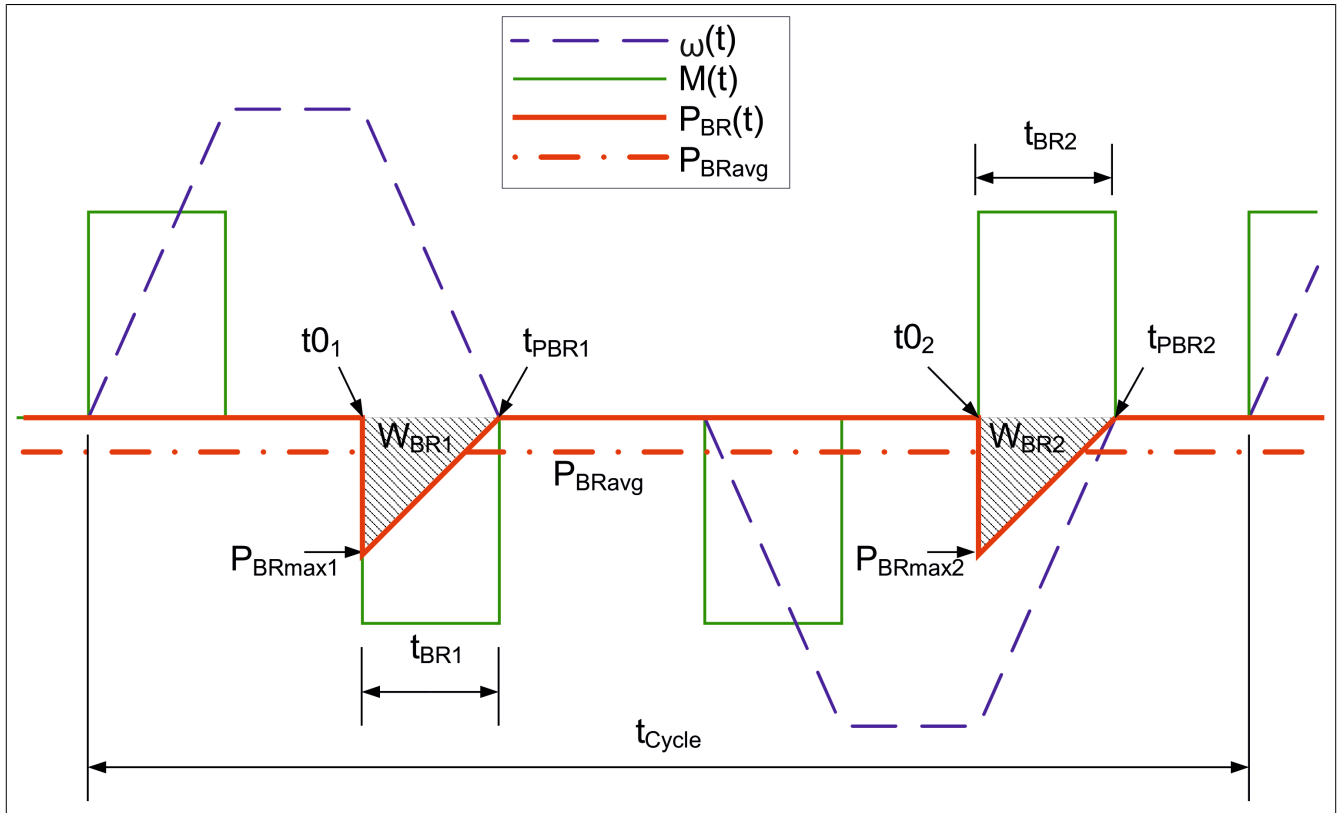


Figure 82: Movement and load profile for one axis in a sample application

$\omega(t)$	Angular velocity
$P_{BR}(t)$	Brake power
$P_{BRavg}$	Average brake power for one cycle
$M(t)$	Torque
$t_{Cycle}$	Cycle duration
$t_{01}$	Start time for braking procedure 1
$t_{PBR1}$	End time for braking procedure 1
$P_{BRmax1}$	Maximum brake power in braking procedure 1
$W_{BR1}$	Brake power for braking procedure 1
$t_{BR1}$	Duration of braking procedure 1
$t_{02}$	Start time for braking procedure 2
$t_{PBR2}$	End time for braking procedure 2
$P_{BRmax2}$	Maximum brake power in braking procedure 2
$W_{BR2}$	Brake power for braking procedure 2
$t_{BR2}$	Duration of braking procedure 2

**Power calculation**

$$P(t) = M(t) \cdot \omega(t)$$

All instances of  $P(t) < 0$  will be labeled as brake power ratings  $P_{BR}(t)$ .

**Braking energy per braking procedure (responsible for heating up the braking resistor during a braking procedure)**

$$W_{BR_i} = \int_{t_{0_i}}^{t_{P_{BR_i}}} P_{BR_i}(t) dt$$

$$P_{BR_i} < 0$$

**Braking energy for one cycle (responsible for average heating of the braking resistor)**

$$W_{BRges} = \sum_{i=1}^N W_{BR_i}$$

**Maximum brake power within one cycle (determinant variable for selecting the braking resistor value)**

$$W_{BRges} = \sum_{i=1}^N W_{BR_i}$$

**Average brake power for one cycle (determinant variable for the required continuous power of the braking resistor)**

$$P_{BRavgAPPL} = \frac{W_{BRges}}{t_{Cycle}}$$

**Total braking time within one cycle (determinant variable for determining the duty cycle ratio)**

$$t = \sum_0^{t_{Cycle}} t_{BR_i}$$

**Determining braking resistor data**

The following parameters must be determined for an external braking resistor according to the application:

- Resistor value ( $R_{BR}$ )
- Nominal continuous power ( $P_{BRN}$ )

Further parameters for external braking resistors can be taken from the manufacturer's data sheet:

- Thermal capacity ( $C_{th}$ )
- Thermal resistance ( $R_{th}$ )
- Maximum overtemperature on the external braking resistor ( $\Delta T_{BRmax}$ ) or absorbed heat up to  $\Delta T_{BRmax} (Q_{BRmax})^{20)}$

**Data for B&R 8B0W braking resistors**

Model number	Mounting orientation	$R_{BR}$ [ $\Omega$ ]	$T_{BRmax}$ [ $^{\circ}C$ ] <sup>1)</sup>	$R_{th}$ [K/W]	$C_{th}$ [J/K]	$Q_{BRmax}$ [J] <sup>1) 2)</sup>	$P_{BRN}$ [W] <sup>1) 2)</sup>
8B0W0045H000.00x-1	Vertical	50	682	1.517	16.3	10465	450
	Horizontal	50	682	1.897	16.3	10465	360
8B0W0079H000.00x-1	Vertical	33	673	0.852	22.6	14306	790
	Horizontal	33	673	1.065	22.6	14306	632

Table 172: Overview of braking resistor data - 8B0W

- 1)  $T_{BRmax}$  can be reduced by application-related limitations (contact protection, warming of neighboring components, maximum warming of the control cabinet, installation position, etc.). In this case, the values for  $Q_{BRmax}$  and  $P_{BRN}$  will also change; these must be recalculated for the maximum value of  $T_{BRmax}$  permitted in the application!
- 2) Values for  $T_{amb} = 40^{\circ}C$ .

<sup>20)</sup> Value for ambient temperature  $T_{amb} = 40^{\circ}C$ .

**Series and parallel connection of braking resistors**

Parameter	Serial connection	Parallel connection
Resistance value	$R_{ges} = \sum_{i=1}^N R_i$	$\frac{1}{R_{ges}} = \sum_{i=1}^N \frac{1}{R_i}$
Thermal resistance	$\frac{1}{R_{thges}} = \sum_{i=1}^N \frac{1}{R_{thi}}$	$\frac{1}{R_{thges}} = \sum_{i=1}^N \frac{1}{R_{thi}}$
Thermal capacity	$C_{th} = \sum_{i=1}^N C_{thi}$	$C_{th} = \sum_{i=1}^N C_{thi}$
Max. permissible temperature	$T_{max} = T_{max}$	$T_{max} = T_{max}$
Absorbed heat up to $T_{max}$	$Q_{maxges} = \sum_{i=1}^N Q_{maxi}$	$Q_{maxges} = \sum_{i=1}^N Q_{maxi}$

Table 173: Series and parallel connection of braking resistors

Maximum heat that can be absorbed by the braking resistor:

$$Q_{BRmax} = (T_{BRmax} - T_{amb}) \cdot C_{th}$$

Maximum temperature in continuous operation:

$$\Delta T_{Dauer} = P_{avg} \cdot R_{th}$$

Average overtemperature in continuous operation:

$$\Delta T_{BR} = \frac{W_{BRges}}{C_{th}}$$

Thermal time constant of the braking resistor:

$$\tau = R_{th} \cdot C_{th}$$

### 4.3.2 Example

#### Scenario

An axis has the following movement and load profile:

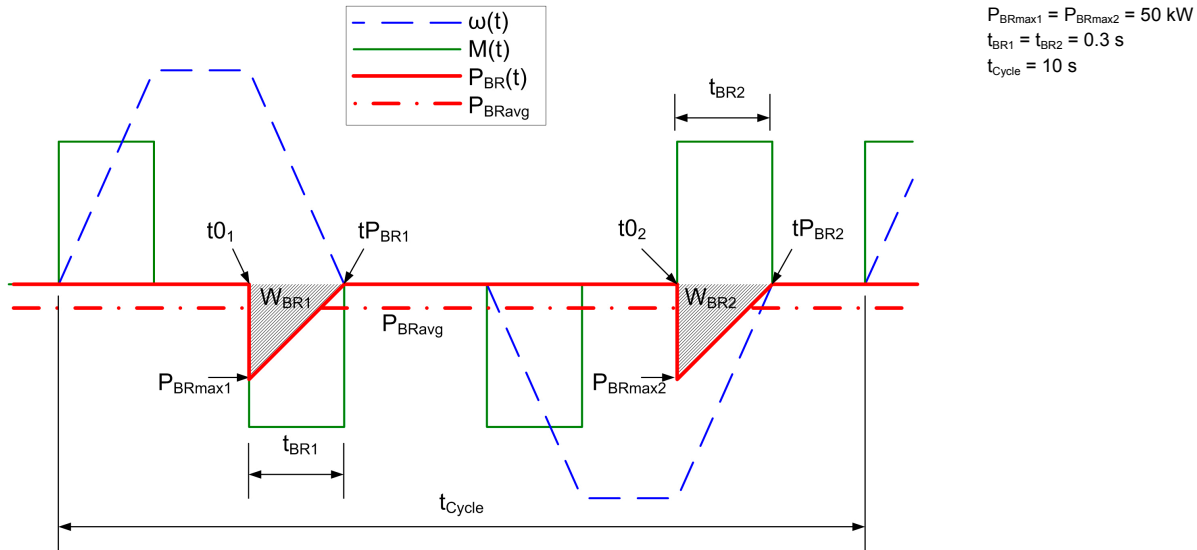


Table 174: Example: Movement and load profile of one axis

- The ambient temperature is 40°C.
- There are no application-related limitations for the maximum surface temperature of the braking resistor.

#### Calculation

Step 1: Determine the maximum brake power within one cycle.

$$P_{BRmaxAPPL} = P_{BRmax1} = P_{BRmax2} = 50\text{ kW}$$

Step 2: Determine the average brake power for one cycle.

$$W_{BRges} = \frac{P_{BRmax1} \cdot t_{BR1}}{2} + \frac{P_{BRmax2} \cdot t_{BR2}}{2} = \frac{50\text{ kW} \cdot 0,3\text{ s}}{2} + \frac{50\text{ kW} \cdot 0,3\text{ s}}{2} = 15\text{ kJ}$$

$$P_{BRavgAPPL} = \frac{W_{BRges}}{t_{Cycle}} = \frac{15\text{ kJ}}{10\text{ s}} = 1,5\text{ kW}$$

Step 3: Determine the right ACOPOS servo drive.

The following criteria must be met:

$$P_{maxServo} \geq P_{BRmaxAPPL} \Rightarrow P_{maxServo} \geq 50\text{ kW}$$

$$I_{BRServo} \geq \frac{\sqrt{P_{BRavgAPPL} \cdot P_{BRavgAPPL}}}{U_{DC}} \Rightarrow I_{BRServo} \geq \frac{\sqrt{1500\text{ W} \cdot 50000\text{ W}}}{800\text{ V}} \Rightarrow I_{BRServo} \geq 10,83\text{ A}$$

The ACOPOS servo drive 8V1640.00-2 meets these criteria (see "Table 170: Braking resistors for ACOPOS servo drives" on page 216):

- $P_{maxServo} = 250\text{ kW} \geq 50\text{ kW}$
- $I_{BRServo} = 30\text{ A} \geq 10.83\text{ A}$

Can the selected ACOPOS servo drive conduct the peak power for the required braking duration for each individual braking procedure within the cycle?

This can be checked using the following diagrams:

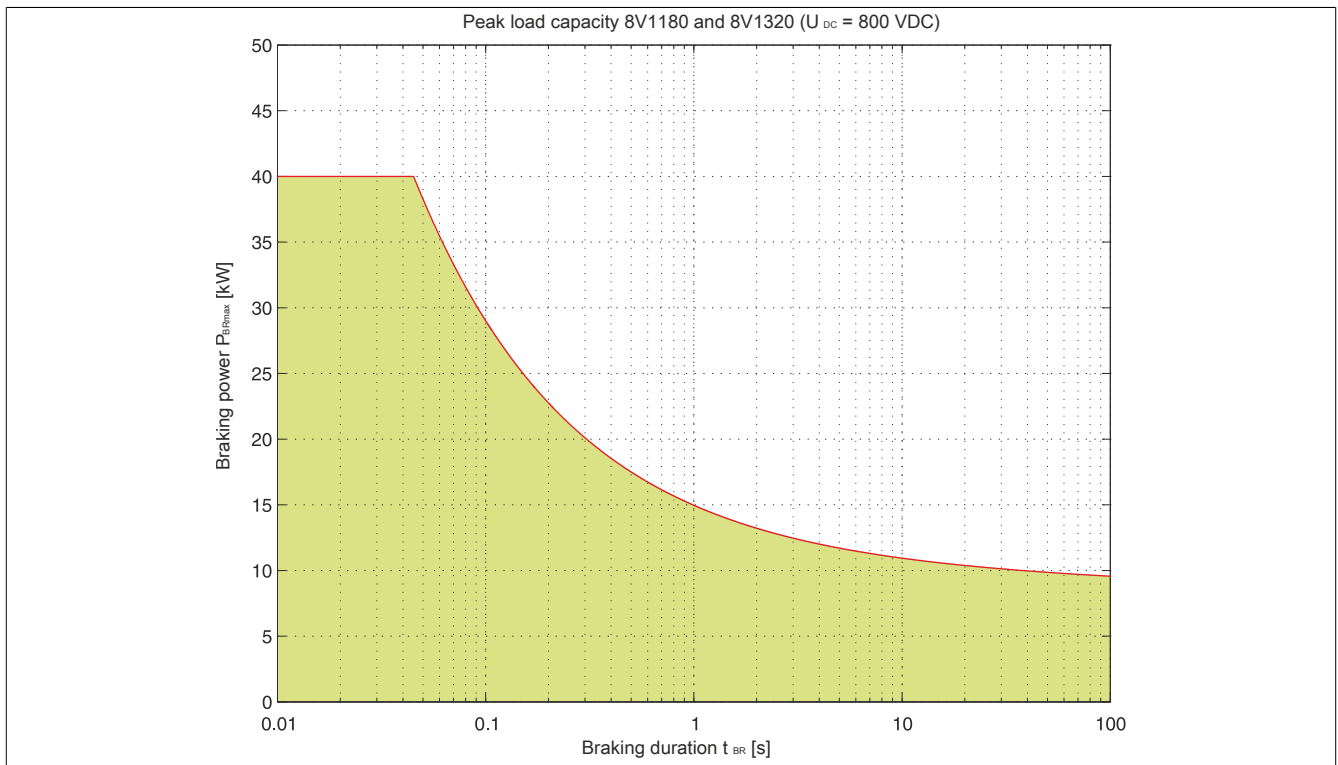


Figure 83: Peak load capacity - 8V1180 / 8V1320

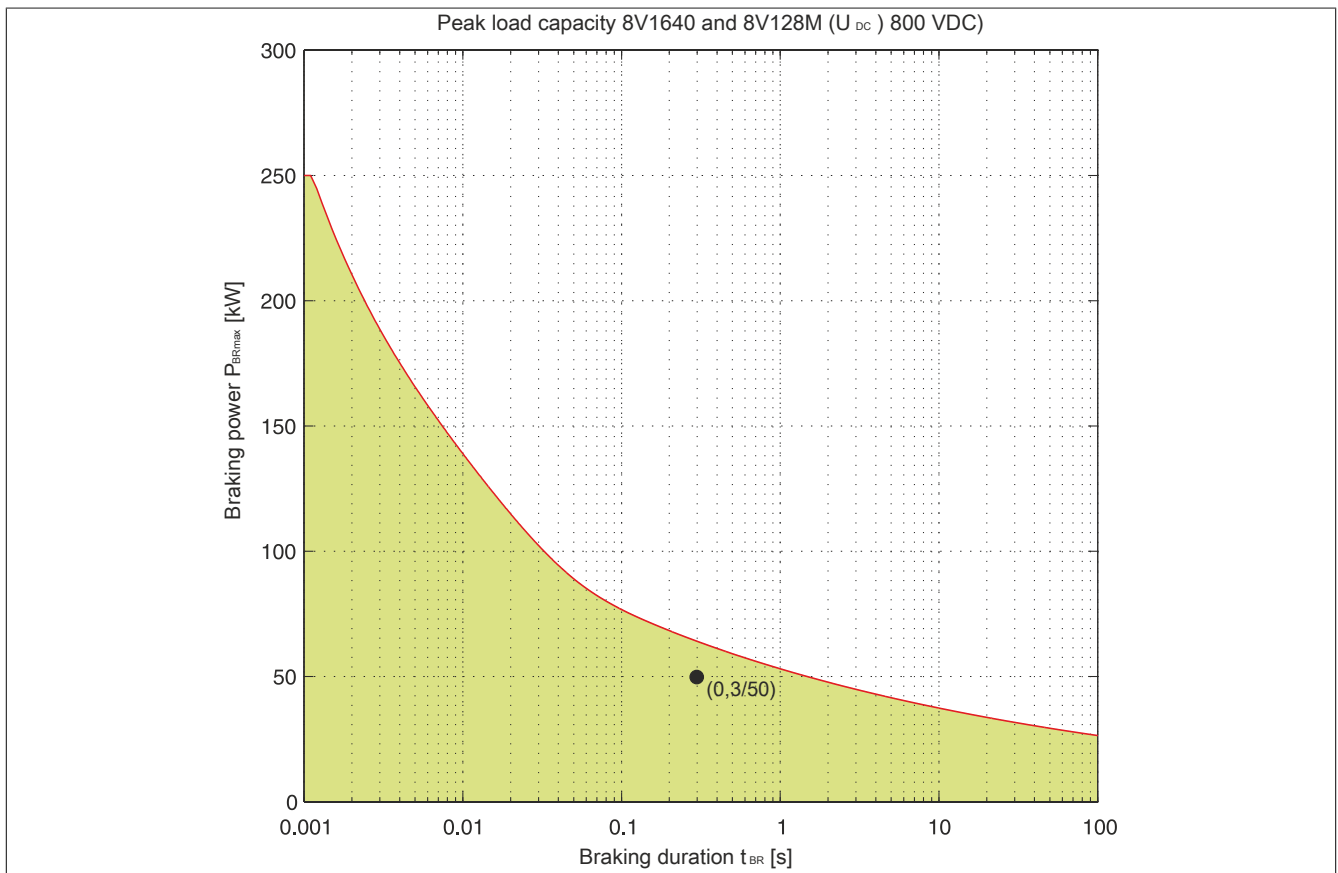


Figure 84: Peak load capacity - 8V1640 / 8V128M

The individual braking procedures within one cycle are entered in the diagram as points with the coordinates (t<sub>BR</sub>/P<sub>BRmax</sub>) and must all be within the permissible range (marked green). If this is not the case, then a different ACOPOS servo drive must be selected!

Figure "Figure 84: Peak load capacity - 8V1640 / 8V128M" contains the individual braking procedures from the sample application ( $t_{BR} = 0.3 \text{ sec}$ ,  $P_{BRmax} = 50 \text{ kW}$ ). These are within the permissible range, which indicates that the selected ACOPOS servo drive is suitable for the peak power of each individual braking procedure in the application.

Step 4: Determine value of the required external braking resistor.

Maximum permissible braking resistor for the application:

$$R_{BRmaxAPPL} = \frac{U_{DCmax}^2}{P_{BRmaxAPPL}} = \frac{800V^2}{50000W} = 12,8 \Omega$$

The value of the external braking resistor must meet the following criteria:

- $R_{BR} \geq R_{minServo} \Rightarrow R_{BR} \geq 2.5 \Omega$
- $R_{BR} \geq \frac{P_{BRavgAPPL}}{I_{BRServo}^2} \Rightarrow R_{BR} \geq \frac{1500W}{30A^2} \Rightarrow R_{BR} \geq 1,67 \Omega$
- $R_{BR} \leq R_{BRmaxAPPL} \Rightarrow R_{BR} \leq 12.8 \Omega$

Therefore, a braking resistor or a combination of braking resistors must be selected with a resistance value between 2.5  $\Omega$  and 12.8  $\Omega$ .

Step 5: Select the external braking resistor.

### Caution!

If the resistance falls below the minimum permitted value, then the brake chopper in the device could be destroyed!

### Danger!

During braking, voltages up to 900 VDC can occur on the external braking resistor. The external braking resistor must be able to handle these voltages.

### Information:

We recommend choosing braking resistor value so that its resistance value  $R_{BR}$  is as close as possible to the maximum value permissible for the application  $R_{BRmax}$ , in order to keep the current low through the fuse on the ACOPOS servo drive's braking resistor connection.

This can require a parallel or series connection of individual braking resistors.

Three braking resistors 8B0W0079H000.001-1 ( $R_{BR} = 33 \Omega$ ) will be connected in parallel to maintain a resistance value that is right for the application (for technical data, see "Table 172: Overview of braking resistor data - 8B0W" on page 220):

- Resistance value:

$$\frac{1}{R_{BR}} = \sum_{i=1}^N \frac{1}{R_{BRi}} \Rightarrow R_{BR} = 11 \Omega \leq 12,8 \Omega$$

- Thermal capacity:

$$c_{th} = \sum_{i=1}^N c_{thi} \Rightarrow c_{th} = 77,8 \frac{J}{K}$$

The continuous power  $P_{BRN}$  and the thermal resistance  $R_{th}$  of the selected combination of braking resistors depends on the mounting orientation:

- Horizontal mounting orientation:

$$\frac{1}{R_{th}} = \sum_{i=1}^N \frac{1}{R_{thi}} \Rightarrow R_{th} = 0,355 \Omega$$

$$P_{BRN} = \sum_{i=1}^N P_{BRNi} \Rightarrow P_{BRN} = 1896W$$

- Vertical mounting orientation:

$$\frac{1}{R_{th}} = \sum_{i=1}^N \frac{1}{R_{th_i}} \Rightarrow R_{th} = 0,284 \Omega$$

$$P_{BRN} = \sum_{i=1}^N P_{BRN} \Rightarrow P_{BRN} = 2370W$$

## Information:

The nominal continuous power  $P_{BRN}$  of a braking resistor depends on the ambient temperature and the braking resistor's maximum permissible temperature.

The braking resistor's nominal power will be decreased if, for application reasons, the ambient temperature is increased and/or the braking resistor's maximum permissible temperature is limited (contact protection, warming of neighboring components, maximum warming of the control cabinet, installation position, etc.)!

### Only for ACOPOS servo drives in the DC bus network!

The braking resistors integrated in ACOPOS servo drives as well as braking resistors that can be connected externally are controlled using a specially developed procedure. This guarantees that the brake power is optimally and equally distributed on the braking resistors when the DC bus connection of ACOPOS servo drives is made between several units.

The following condition must be met for the external braking resistor in order for this occur:  $P_{BRN} \geq \frac{U_{DC}^2}{30 \cdot R_{BR}}$

- Horizontal mounting orientation:

$$P_{BRN} \geq \frac{U_{DC}^2}{30 \cdot R_{BR}} \Rightarrow 1896W \geq \frac{800V^2}{30 \cdot 11\Omega} \Rightarrow 1896W \geq 1939W$$

--> Condition not met.

- Vertical mounting orientation:

$$P_{BRN} \geq \frac{U_{DC}^2}{30 \cdot R_{BR}} \Rightarrow 2370W \geq \frac{800V^2}{30 \cdot 11\Omega} \Rightarrow 2370W \geq 1939W$$

--> Condition met.

Is the nominal continuous power  $P_{BRN}$  of the selected braking resistor combination sufficient for the application's average brake power  $P_{BRavgAPPL}$ ?

The following condition must be met:

$$P_{BRN} \geq P_{BRavgAPPL}$$

This condition must be checked for all permissible mounting orientations:

- Horizontal mounting orientation:

$$P_{BRN} \geq P_{BRavgAPPL} \Rightarrow 1896W > 1500W \text{ --> Nominal continuous power } P_{BRN} \text{ is sufficient.}$$

- Vertical mounting orientation:

$$P_{BRN} \geq P_{BRavgAPPL} \Rightarrow 2370W > 1500W \text{ --> Nominal continuous power } P_{BRN} \text{ is sufficient.}$$

Can the selected braking resistor conduct the incidental braking energy without exceeding the maximum braking resistor temperature for the application?

The following condition must be met for this to happen:

$$P_{BRN} \geq \frac{W_{BR_i}}{t_i} \cdot k$$

The peak load factor  $k$  for any braking resistor can be determined using the following diagram:

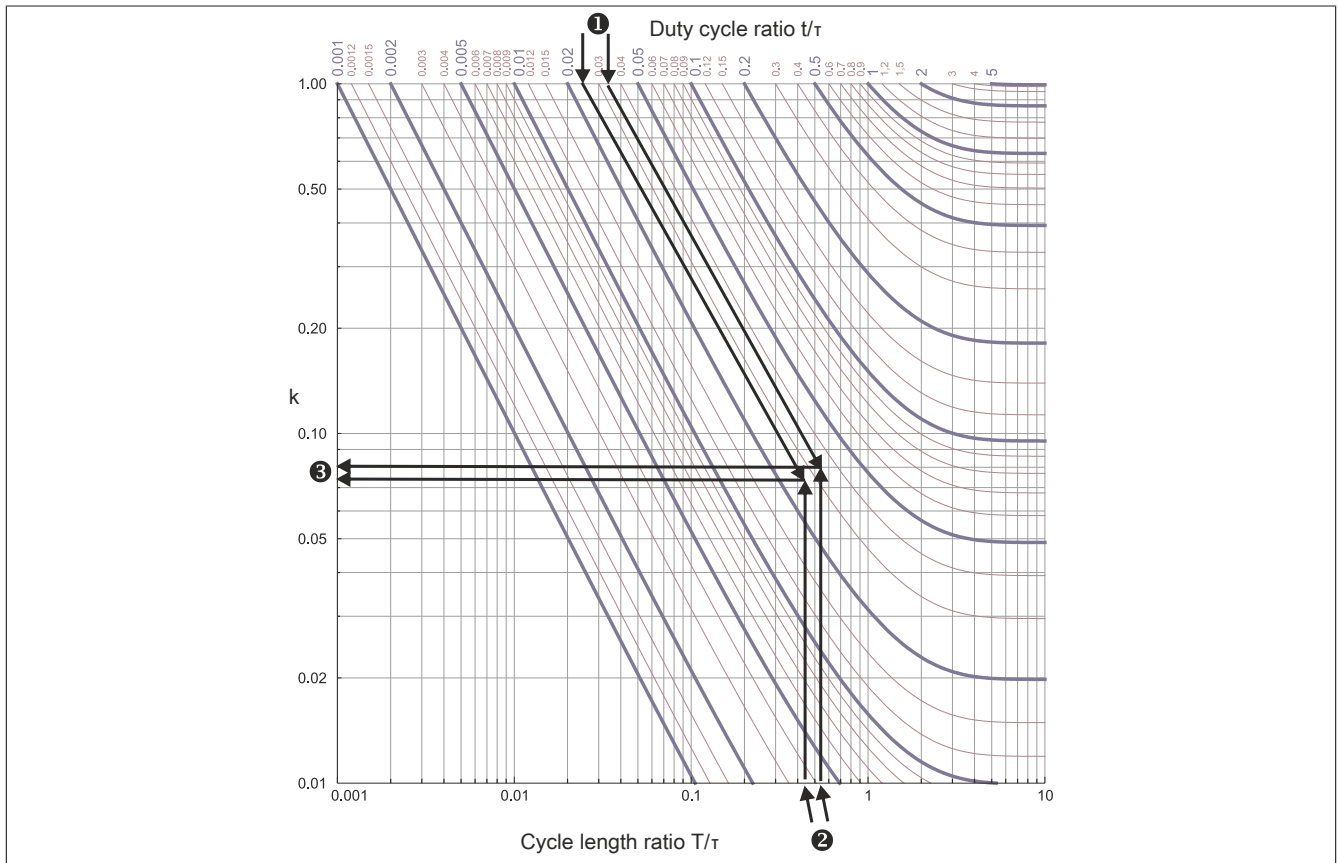


Figure 85: Determining the peak load factor  $k$

- $k$  ... Peak load factor for the braking resistor
- $T$  ... Application cycle time (=  $t_{\text{cycle}}$ )
- $t$  ... Sum of all braking times (total braking time) within one cycle
- $\tau$  ... Thermal time constant of the braking resistor (=  $R_{\text{th}} \cdot c_{\text{th}}$ )

### 1. Calculation of the duty cycle ratio

- Horizontal mounting orientation:

$$\frac{t}{T} = \frac{t_{BR1} + t_{BR2}}{R_{th} + c_{th}} = \frac{0,3 + 0,3}{0,355.67,8} = 0,025$$

- Vertical mounting orientation:

$$\frac{t}{T} = \frac{t_{BR1} + t_{BR2}}{R_{th} + c_{th}} = \frac{0,3 + 0,3}{0,284.67,8} = 0,031$$

### 2. Calculation of the cycle length ratio

- Horizontal mounting orientation:

$$\frac{T}{\tau} = \frac{t_{\text{Cycle}}}{R_{th} \cdot c_{th}} = \frac{10}{0,355.67,8} = 0,415$$

- Vertical mounting orientation:

$$\frac{T}{\tau} = \frac{t_{\text{Cycle}}}{R_{th} \cdot c_{th}} = \frac{10}{0,284.67,8} = 0,519$$

### 3. Reading the peak load factor $k$ based on the values from 1 and 2 in figure "Calculation of the peak load factor $k$ "

- Horizontal installation:  $k = 0.075$
- Vertical installation:  $k = 0.08$

This condition must be checked for all permissible mounting orientations:

- Horizontal mounting orientation:

$$P_{BRN} \geq \frac{W_{BRi}}{t_i} \cdot k \Rightarrow 1896W \geq \frac{7500J}{0,3s} \cdot 0,075 \Rightarrow 1896W \geq 1875W$$

--> The nominal power  $P_{BRN}$  of the braking resistor is barely sufficient for the application - **No reserves!**  
Horizontal mounting orientations are therefore not recommended!

- Vertical mounting orientation:

$$P_{BRN} \geq \frac{W_{BRi}}{t_i} \cdot k \Rightarrow 2370W \geq \frac{7500J}{0,3s} \cdot 0,08 \Rightarrow 2370W \geq 2000W$$

--> The nominal power  $P_{BRN}$  of the braking resistor is sufficient for the application.

## Results

Three B&R braking resistors 8B0W0079H000.001-1 connected in parallel and installed vertically on an ACOPOS servo drive 8V1640.00-2 power supply module meet the requirements of the application.

## 4.4 Configuring brake resistor parameters

The braking resistors integrated in B&R drive systems or connected externally are controlled by a specially developed procedure. This guarantees that the brake power is optimally and equally distributed on the braking resistors when a DC bus connection is made between several units.

### 4.4.1 Using the integrated braking resistors

No settings or configuration is required by the user.

### 4.4.2 Using external braking resistors

When using external braking resistors, the following parameters must be set for the drive system using B&R Automation Studio:

ParID	Name	Formula symbols	Unit
10	Ohmic resistance	$R_{BR}$	[ $\Omega$ ]
11	Maximum overtemperature on the external braking resistor	$\Delta T_{BRmax}$	[ $^{\circ}C$ ]
12	Thermal resistance between braking resistor and the environment	$R_{th}$	[K/W]
13	Heat capacitance of the filament	$C_{th}$	[Ws/ $^{\circ}C$ ]
398	Setting for an internal / external braking resistor  0 ... Internal (default) 1 ... External	---	---
<p><b>Information:</b></p> <p>Switching is only possible during the ACOPOS servo drive initialization phase.</p>			

Table 175: ParIDs for setting external braking resistor parameters

These parameters can normally be found on the data sheet from the respective manufacturer. <sup>21)</sup>

These parameters are based on the following thermal equivalent circuit diagram for the external braking resistor:

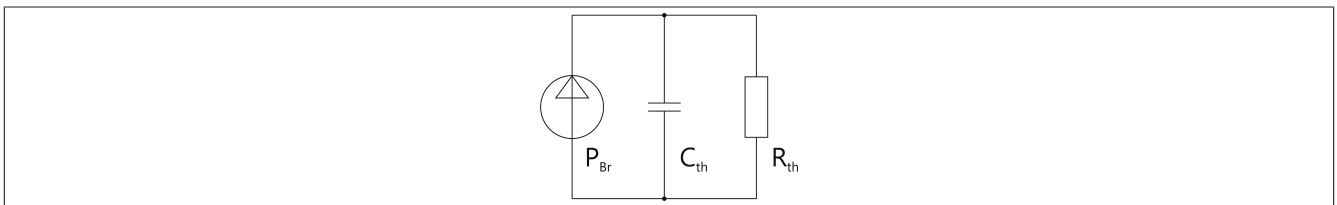


Figure 86: Thermal equivalent circuit diagram for the external braking resistor

If a value for the maximum overtemperature  $T_{BRmax}$  of the external braking resistor is not given, it can be determined using the following formula:

$$T_{BRmax} = P_{BRN} \cdot R_{th}$$

<sup>21)</sup> An example of reliable braking resistors are  $\Sigma$  SIGMA type braking resistors ([www.danotherm.com](http://www.danotherm.com)).

## 5 Configuring ACOPOS servo drives

The plug-in modules for ACOPOS servo drives allow each servo drive to be individually configured according to the requirements of the application. When putting together plug-in module combinations, the power consumption must be checked. This then results in the current requirements of the ACOPOS servo drive configuration.

### 5.1 Maximum power output for all slots on the ACOPOS servo drive

The maximum power output for all slots ( $P_{max}$ ) depends on the size of the ACOPOS servo drive:

Name	ACOPOS								
	1010	1016	1022	1045	1090	1180	1320	1640	128 M
$P_{max}$	Max. 16 W			Max. 22 W					

Table 176: Maximum power output for all slots depending on the ACOPOS servo drive

The total power consumption for all plug-in modules must be less than or equal to the ACOPOS servo drive's maximum power output:

$$\sum P_{Module}[W] \leq P_{max}[W]$$

The power consumption of the individual plug-in modules can be found in "Table 176: Power consumption P<sub>module</sub> of ACOPOS plug-in modules" or the technical data for the modules (see "Technical data" on page 29):

Plug-in module	Power consumption P <sub>module</sub>
8AC110.60-2	Max. 0.7 W
8AC114.60-2	Max. 3 W
8AC120.60-1	Depends on the EnDat encoder connected
E0 ... EnDat single-turn, 512 lines	Max. 2.3 W
E1 ... EnDat multi-turn, 512 lines	Max. 3.1 W
E2 ... EnDat single-turn, 32 lines (inductive)	Max. 3.1 W
E3 ... EnDat multi-turn, 32 lines (inductive)	Max. 3.1 W
E4 ... EnDat single-turn, 512 lines	Max. 2.4 W
E5 ... EnDat multi-turn, 512 lines	Max. 2.7 W
8AC121.60-1	
With encoder current requirement of 0 mA	0.35 W
With encoder current requirement of 100 mA	1.4 W
With encoder current requirement of 170 mA	2.1 W
8AC122.60-3	Max. 2.5 W
8AC123.60-1	Max. 7.5 W
	Depends on the current requirements for the encoder connected <sup>1)</sup>
8AC125.60-1	In preparation
8AC126.60-1	In preparation
8AC130.60-1	Max. 0.8 W
8AC131.60-1	Max. 1 W
8AC140.60-3, 8AC140.61-3	Max. 4.5 W
8AC141.60-2, 8AC141.61-3	Max. 4.5 W

Table 177: Power consumption P<sub>module</sub> of ACOPOS plug-in modules

- 1) The power consumption of the plug-in module can be approximated using the following formula:

$$P_{Module} [W] = P_{Encoder} [W] \cdot k + 0.6 W$$

The power consumed by the encoder  $P_{Encoder}$  is calculated from the selected encoder supply voltage (5 V / 15 V) and the current required:

$$P_{Encoder} [W] = U_{Encoder} [V] \cdot I_{Encoder} [A]$$

The following values must be used for k:

k = 1.2 (for 15 V encoder supply)

k = 1.75 (for 5 V encoder supply)

## 5.2 24 VDC current requirements for the ACOPOS servo drive

The 24 VDC current requirements ( $I_{24VDC}$ ) must be regarded differently depending on the size of the ACOPOS servo drive.

- The following estimate can always be used for the ACOPOS 1010, 1016, 1022, 1045 and 1090:

$$I_{24VDC}[A] = I_{24VDC_{max}}[A] - \frac{1,1}{24V \cdot k} (P_{max} - \sum P_{Modul}[W])$$

- This estimate can also be used for the ACOPOS 1180, 1320, 1640 and 128M as long as a mains input voltage is not applied. As soon as a mains input voltage is applied to these servo drives, the 24 VDC supply voltage is created via the integrated DC bus power supply; the 24 VDC current requirements ( $I_{24VDC}$ ) is then reduced to 0.

The 24 VDC maximum current requirements for the ACOPOS servo drives can be found in "Table 177: Maximum current requirements and constant k" or the technical data for the ACOPOS servo drives (see "Technical data").

Name	ACOPOS									
	1010	1016	1022	1045	1090	1180	1320	1640	128 M	
$I_{24VDC_{max}}$	1.47 A		2.5 A			2.8 A		4.6 A	5.7 A	
k	0.73		0.64			0.63		0.58		

Table 178: Maximum current requirements and constant k

The 24 VDC total current consumption for the ACOPOS servo drive is made up of the 24 VDC current requirements, the current on the 24 VDC output (only for ACOPOS 1180/1320/1640/128M) and the current for the motor holding brake (if used):

$$I_{24VDC_{total}} = I_{24VDC} + I_{24VDC_{out}} + I_{Br}$$

In this case, make sure that the 24 VDC total current consumption does not exceed the maximum current load for the connection terminals.

## 6 Dimensioning cooling systems for cooling control cabinets

### 6.1 General dimensioning criteria

- What are the environmental conditions where the control cabinet will be located (ambient temperature  $T_A$ , humidity, installation altitude above sea level)?
- How is the air circulation (intake and outlet) where the control cabinet will be located? Particularly small spaces can become significantly warmer due to the heat dissipation from a cooling device.
- Is the ambient air clean or contaminated with dust, oil, etc?
- Which type of control cabinet installation is intended according to DIN 57660, Part 500?
- Is the control cabinet open (allowing air flow) or closed (no air flow)? Control cabinets that are closed (no air flow) can only dissipate power loss via the control cabinet walls.
- What kind of material are the control cabinet walls made of (specification of the heat transfer coefficient  $k$ )?
- What is the control cabinet's minimum required level of protection in accordance with EN 60529?
- How high is the specified internal temperature  $T_{Iset}$  of the control cabinet? This value must be lower than the lowest permissible ambient temperature of all components used in the control cabinet.
- Is a coolant circulation available where the control cabinet is located?
- Is the maximum ambient temperature  $T_{Amax}$  lower than the desired internal temperature  $T_{Iset}$  of the control cabinet?

#### 6.1.1 Basic selection of the cooling system

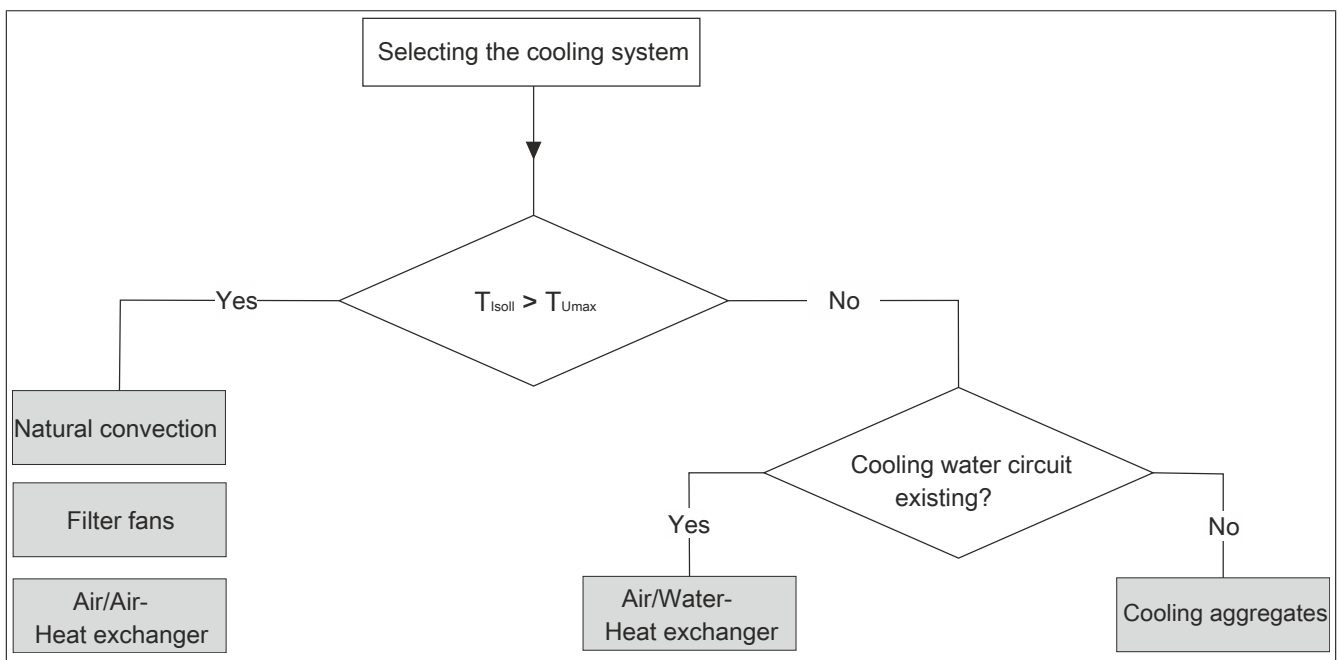


Figure 87: Basic selection of the cooling system

## 6.2 Natural convection

In this case, the power loss is emitted outwards through the control cabinet walls.

### Information:

The ambient temperature  $T_A$  must be considerably lower than the internal temperature  $T_I$  of the control cabinet.

The heat capacity emitted from the control cabinet to the environment strongly depends on how the control cabinet is installed: A housing located in an open space can emit more heat to its environment than a housing that is mounted to a wall or built into a recess.

The calculation of the effective control cabinet surface  $A$  depending on the type of control cabinet installation is determined in DIN VDE 57 660 part 500 or IEC 890 (and VDE 0660 part 890):








Mounting arrangement in accordance with IEC 890	Formula for calculating $A$ [m <sup>2</sup> ] <sup>1)</sup>
 Detached single cabinet, free-standing on all sides	$A = 1.8 \times H \times (W + D) + 1.4 \times W \times D$
 Single cabinet, against a wall	$A = 1.4 \times W \times (H + D) + 1.8 \times D \times H$
 First or last cabinet, detached on three sides	$A = 1.4 \times D \times (H + W) + 1.8 \times W \times H$
 First or last cabinet, against a wall	$A = 1.4 \times H \times (W + D) + 1.4 \times W \times D$
 Middle cabinet, detached on two sides	$A = 1.8 \times W \times H + 1.4 \times W \times D + D \times H$
 Middle cabinet, against a wall	$A = 1.4 \times W \times (H + D) + D \times H$
 Middle cabinet, against a wall, with covered roof	$A = 1.4 \times W \times H + 0.7 \times W \times D + D \times H$

Table 179: Calculation of the effective control cabinet surface  $A$  (DIN VDE 57 660 part 500 or IEC 890)

1)  $W$  ... Control cabinet width [m];  $H$  ... Control cabinet height [m];  $D$  ... Control cabinet depth [m].

### 6.2.1 Dimensioning

1. Determine the heat dissipation  $Q_v$  of all devices in the control cabinet.
2. Calculate the effective control cabinet surface area  $A$ .
3. Calculate the maximum control cabinet temperature  $T_{I_{max}}$ :<sup>22)</sup>

$$T_{I_{max}} = \frac{Q_v}{k \cdot A} + T_U$$

The control cabinet's maximum internal temperature  $T_{I_{max}}$  must be lower than the maximum permissible ambient temperature of the components used inside the control cabinet.

### 6.2.2 Example

Two ACOPOS 8V1320.00-2 units and an ACOPOS 8V1640.00-2 are installed in a control cabinet. The heat dissipation from the braking resistors was determined over one machine cycle and is on average 800 W. The heat dissipation from all other active devices in the control cabinet is 500 W.

The steel control cabinet is 1 m wide, 2 m high, 0.5 m deep and is free-standing on all sides. The internal temperature of the control cabinet should not exceed 40°C. The ambient temperature is 30°C.

Now determine whether the heat dissipation occurring in the control cabinet can be diverted by its own natural convection.

#### 1) Determine the heat dissipation of all devices in the control cabinet.

Components in the control cabinet	Quantity	Heat dissipation per component [W]	Total heat dissipation [W]
8V1320.00-2	2	800 <sup>1)</sup>	1600
8V1640.00-2	1	1600 <sup>1)</sup>	1600
Braking resistors	---	800 (average value over one machine cycle)	800
All other active devices	---	---	500
<b>Total:</b>			<b>4500</b>

Table 180: Determining the heat dissipation of all devices in the control cabinet

1) The heat dissipation for ACOPOS servo drives is specified in the "Technical data" chapter. Maximum values are used in this example.

<sup>22)</sup>  $k$  ... Heat transfer coefficient [W/m<sup>2</sup>K]; for steel panel:  $k = 5.5$

If the heat dissipation  $Q_v$  in the control cabinet is unknown, the actual power loss can be calculated by measuring  $T_A$  and  $T_I$ :  $Q_v = A \cdot k \cdot (T_{I_{max}} - T_A)$

**2) Calculate the effective control cabinet surface area.**

$$A = 1.8 \times H \times (W + D) + 1.4 \times W \times D = 1.8 \times 2 \times (1+0.5) + 1.4 \times 1 \times 0.5 = 6.1 \text{ m}^2$$

**3) Calculate the control cabinet inside temperature  $T_I$ .**

$$T_I = \frac{Q_V}{k \cdot A} + T_U = \frac{4500}{5,56,1} + 30 = 104^\circ\text{C}$$

The control cabinet's calculated internal temperature considerably exceeds the desired internal temperature of  $40^\circ\text{C}$ . Therefore, the heat dissipation occurring inside the control cabinet cannot be diverted by its own natural convection. Another method must be used for cooling the control cabinet.

**6.3 Filter fans**

Filter fans are also a simple type of control cabinet cooling. The heat is dissipated by adding ambient air circulation and simultaneously allowing the heated air inside the control cabinet to be diverted.

**Information:**

To use filter fans, the ambient temperature  $T_A$  must be considerably lower than the internal temperature  $T_I$  of the control cabinet.

**6.3.1 Dimensioning**

1. Determine the heat dissipation  $Q_V$  of all devices in the control cabinet.
2. Determine the control cabinet's maximum internal temperature  $T_{I\max}$  at nominal load or identify it using the maximum ambient temperature of the components being used.
3. Specify the ambient temperature  $T_A$  of the control cabinet.
4. Specify the control cabinet's installation altitude  $h$ .

Depending on the control cabinet's installation altitude, a compensation factor  $f$  might be required, which can be found in the following table:

Installation altitude $h$ [m]	Compensation factor $f$ [ $\text{m}^3\text{K}/\text{Wh}$ ]
$0 \leq h \leq 100$	3.1
$100 < h \leq 250$	3.2
$250 < h \leq 500$	3.3
$500 < h \leq 750$	3.4
$750 < h \leq 1000$	3.5

Table 181: Compensation factor  $f$  depending on the control cabinet's installation altitude

5. Calculate the air flow volume  $V$ :

$$V[\text{m}^3/\text{h}] = f \cdot \frac{Q_V}{T_{I\max} - T_U}$$

The correct filter fan can now be selected based on the calculated air flow volume  $V$ .

**Information:**

The required protection level of the control cabinet in accordance with EN 60529 must also be taken into consideration when selecting a filter fan.

**6.3.2 Example**

Two ACOPOS 8V1320.00-2 units and an ACOPOS 8V1640.00-2 are installed in a control cabinet. The heat dissipation from the braking resistors was determined over one machine cycle and is on average 800 W. The heat dissipation from all other active devices in the control cabinet is 500 W.

The internal temperature of the control cabinet should not exceed  $40^\circ\text{C}$ . The ambient temperature is  $30^\circ\text{C}$ . The control cabinet should be installed at 800 m above sea level.

The right filter fan must be selected for this control cabinet.

**1) Determine the heat dissipation of all devices in the control cabinet.**

Components in the control cabinet	Quantity	Heat dissipation per component [W]	Total heat dissipation [W]
8V1320.00-2	2	800 <sup>1)</sup>	1600
8V1640.00-2	1	1600 <sup>1)</sup>	1600
Braking resistors	---	800 (average value over one machine cycle)	800
All other active devices	---	---	500
<b>Total:</b>			<b>4500</b>

Table 182: Determining the heat dissipation of all devices in the control cabinet

1) The heat dissipation for ACOPOS servo drives is specified in the "Technical data" chapter. Maximum values are used in this example.

**2) Determine the control cabinet's maximum internal temperature  $T_{lmax}$  at nominal load or identify it using the maximum ambient temperature of the components being used.**

The internal temperature of the control cabinet should not exceed 40°C.

**3) Specify the ambient temperature  $T_A$  of the control cabinet.**

The ambient temperature is 30°C.

**4) Specify the control cabinet's installation altitude  $h$ .**

The compensation factor  $f$  can be taken from table "Compensation factor  $f$  depending on the control cabinet's installation altitude" and is equal to 3.5 m<sup>3</sup>K/Wh.

**5) Calculate the air flow volume  $V$ .**

This results in an air flow volume of

$$V = f \cdot \frac{Q_v}{T_{lmax} - T_U} = 3,5 \cdot \frac{4500}{40 - 30} = 1575 \text{ m}^3 / \text{h}$$

The correct filter fan can now be selected based on the determined air flow volume.

## 6.4 Air/air heat exchangers

Air/Air heat exchangers dissipate the heat from the control cabinet using two hermetically isolated air currents in the opposing current principle. This prevents dust, oil and other (aggressive) materials in the ambient air from penetrating the control cabinet.

### Information:

To use air/air heat exchangers, the ambient temperature  $T_A$  must be considerably lower than the internal temperature  $T_I$  of the control cabinet.

#### 6.4.1 Dimensioning

1. Determine the heat dissipation  $Q_v$  of all devices in the control cabinet.
2. Determine the control cabinet's maximum internal temperature  $T_{I_{max}}$  at nominal load or identify it using the maximum ambient temperature of the components being used.
3. Specify the ambient temperature  $T_A$  of the control cabinet.
4. Calculate the effective control cabinet surface area  $A$ .
5. Calculate the specific heat capacity  $q_w$ : <sup>23)</sup>

$$q_w \left[ \frac{W}{K} \right] = \frac{Q_v - (A(T_{I_{max}} - T_U) \cdot k)}{T_{I_{max}} - T_U}$$

The right air/air heat exchanger can be selected based on the specific heat capacity  $q_w$ .

### Information:

The required protection level of the control cabinet in accordance with EN 60529 must also be taken into consideration when selecting an air/air heat exchanger.

#### 6.4.2 Example

Two ACOPOS 8V1320.00-2 units and an ACOPOS 8V1640.00-2 are installed in a control cabinet. The heat dissipation from the braking resistors was determined over one machine cycle and is on average 800 W. The heat dissipation from all other active devices in the control cabinet is 500 W.

The steel control cabinet is 1 m wide, 2 m high, 0.5 m deep and is free-standing on all sides. The internal temperature of the control cabinet should not exceed 40°C. The ambient temperature is 30°C.

The right air/air heat exchanger must be selected for this control cabinet.

#### 1) Determine the heat dissipation of all devices in the control cabinet.

Components in the control cabinet	Quantity	Heat dissipation per component [W]	Total heat dissipation [W]
8V1320.00-2	2	800 <sup>1)</sup>	1600
8V1640.00-2	1	1600 <sup>1)</sup>	1600
Braking resistors	---	800 (average value over one machine cycle)	800
All other active devices	---	---	500
<b>Total:</b>			<b>4500</b>

Table 183: Determining the heat dissipation of all devices in the control cabinet

1) The heat dissipation for ACOPOS servo drives is specified in the "Technical data" chapter. Maximum values are used in this example.

#### 2) Determine the control cabinet's maximum internal temperature $T_{I_{max}}$ at nominal load or identify it using the maximum ambient temperature of the components being used.

The internal temperature of the control cabinet should not exceed 40°C.

#### 3) Specify the ambient temperature $T_A$ of the control cabinet.

The ambient temperature is 30°C.

#### 4) Calculate the effective control cabinet surface area.

$$A = 1.8 \times H \times (W + D) + 1.4 \times W \times D = 1.8 \times 2 \times (1 + 0.5) + 1.4 \times 1 \times 0.5 = 6.1 \text{ m}^2$$

<sup>23)</sup> k ... Heat transfer coefficient [W/m<sup>2</sup>K]; for steel panel: k = 5.5

### 5) Calculate the specific heat capacity.

The heat transfer coefficient  $k$  for steel panels is  $5.5 \text{ W/m}^2\text{K}$ .

This results in a specific heat capacity  $q_w$  of

$$q_w = \frac{Q_v - (A \cdot (T_{lmax} - T_U) \cdot k)}{T_{lmax} - T_U} = \frac{4500 - (6,1 \cdot (40 - 30) \cdot 5,5)}{40 - 30} = 416,45 \frac{\text{W}}{\text{K}}$$

The right air/air heat exchanger can be selected based on the determined specific heat capacity  $q_w$ .

## 6.5 Air/water heat exchangers / Cooling units

Air/water heat exchangers and cooling units dissipate heat via a cooling circulation system. This prevents dust, oil and other (aggressive) materials in the ambient air from penetrating the control cabinet.

### 6.5.1 Dimensioning

1. Determine the heat dissipation  $Q_v$  of all devices in the control cabinet.
2. Determine the control cabinet's maximum internal temperature  $T_{lmax}$  at nominal load or identify it using the maximum ambient temperature of the components being used.
3. Specify the ambient temperature  $T_A$  of the control cabinet.
4. Calculate the effective control cabinet surface area  $A$ .
5. Calculate the required cooling capacity  $Q_E$ :<sup>24)</sup>

$$Q_E[\text{W}] = Q_v - (A \cdot (T_{lmax} - T_U) \cdot k)$$

The right air/water heat exchanger or cooling unit can now be selected based on the required cooling capacity  $Q_E$ .

#### Information:

The required protection level of the control cabinet in accordance with EN 60529 must also be taken into consideration when selecting an air/water heat exchanger or cooling unit.

### 6.5.2 Example

#### Scenario

Two ACOPOS 8V1320.00-2 units and an ACOPOS 8V1640.00-2 are installed in a control cabinet. The heat dissipation from the braking resistors was determined over one machine cycle and is on average  $800 \text{ W}$ . The heat dissipation from all other active devices in the control cabinet is  $500 \text{ W}$ .

The steel control cabinet is  $1 \text{ m}$  wide,  $2 \text{ m}$  high,  $0.5 \text{ m}$  deep and is free-standing on all sides. The internal temperature of the control cabinet should not exceed  $40^\circ\text{C}$ . The ambient temperature is  $30^\circ\text{C}$ .

The right air/water heat exchanger or cooling unit must be selected for this control cabinet.

#### 1) Determine the heat dissipation of all devices in the control cabinet.

Components in the control cabinet	Quantity	Heat dissipation per component [W]	Total heat dissipation [W]
8V1320.00-2	2	800 <sup>1)</sup>	1600
8V1640.00-2	1	1600 <sup>1)</sup>	1600
Braking resistors	---	800 (average value over one machine cycle)	800
All other active devices	---	---	500
<b>Total:</b>			<b>4500</b>

Table 184: Determining the heat dissipation of all devices in the control cabinet

1) The heat dissipation for ACOPOS servo drives is specified in the "Technical data" chapter. Maximum values are used in this example.

#### 2) Determine the control cabinet's maximum internal temperature $T_{lmax}$ at nominal load or identify it using the maximum ambient temperature of the components being used.

The internal temperature of the control cabinet should not exceed  $40^\circ\text{C}$ .

#### 3) Specify the ambient temperature $T_A$ of the control cabinet.

The ambient temperature is  $30^\circ\text{C}$ .

<sup>24)</sup>  $k$  ... Heat transfer coefficient [ $\text{W/m}^2\text{K}$ ]; for steel panel:  $k = 5.5$

**4) Calculate the effective control cabinet surface area.**

$$A = 1.8 \times H \times (W + D) + 1.4 \times W \times D = 1.8 \times 2 \times (1 + 0.5) + 1.4 \times 1 \times 0.5 = 6.1 \text{ m}^2$$

**5) Calculate the required cooling capacity.**

The heat transfer coefficient  $k$  for steel panels is  $5.5 \text{ W/m}^2\text{K}$ .

This results in a required cooling capacity  $Q_E$  of

$$Q_E = Q_V - (A(T_{lmax} - T_U) \cdot k) = 4500 - (6,1(40 - 30) \cdot 5,5) = 4164,5 \text{ W}$$

The right air/water heat exchanger or cooling unit can now be selected based on the determined required cooling capacity  $Q_E$ .

## 7 Formula variables used

Character	Unit	Name
A	m <sup>2</sup>	Effective, power radiating control cabinet surface according to DIN 57660 section 500
C <sub>A</sub>	E	Discharge capacitance
C <sub>Brth</sub>	Ws/°C	Heat capacitance of the filament
c <sub>th</sub>	Ws/°C	Thermal capacity
k	---	General constants
f <sub>Mains</sub>	Hz	Mains frequency
I <sub>24VDC</sub>	A	24 VDC current requirements
I <sub>24VDC<sub>max</sub></sub>	A	24 VDC maximum current requirements
I <sub>24VDC<sub>total</sub></sub>	A	24 VDC total current consumption
I <sub>24VDC<sub>out</sub></sub>	A	Current on 24 VDC output of the ACOPOS servo drive (max. 0.5 A)
I <sub>A</sub>	A	Discharge current via protective ground conductor (PE)
I <sub>B</sub>	A	Rated current for overcurrent protection
I <sub>Mains</sub>	A	Mains current (phase current)
I <sub>q</sub>	A	Thermal equivalent current effective value
I <sub>Z</sub>	A	Maximum current load on a cable
k	W/m <sup>2</sup> K	Heat transfer coefficient (for steel: k = 5.5 W/m <sup>2</sup> K)
M	Nm	Torque (general)
M <sub>eff</sub>	Nm	Effective load torque for one cycle
n	min <sup>-1</sup>	Speed (general)
n <sub>avg</sub>	min <sup>-1</sup>	Average speed for one cycle
ω	rad/s	Angular velocity
P	W	Power or true power (general)
P <sub>Br</sub>	W	Brake power
P <sub>Br<sub>max</sub></sub>	W	Maximum brake power
P <sub>Br<sub>avg</sub></sub>	W	Average brake power
P <sub>BRN</sub>	W	Nominal continuous power
P <sub>R<sub>ex</sub></sub>	W	Maximum load on the external braking resistor
P <sub>R<sub>ex</sub></sub>	W	Nominal power of the external braking resistor
P <sub>max</sub>	W	Maximum power output for all slots
P <sub>Module</sub>	W	Power consumption of the ACOPOS plug-in modules
π	---	Pi (3.1415)
Q <sub>E</sub>	W	Necessary cooling capacity
Q <sub>v</sub>	W	Sum of the heat dissipation in the control cabinet
Q <sub>S</sub>	W	Power that is radiated through the control cabinet surface (Q <sub>S</sub> >0: radiation; Q <sub>S</sub> <0: radiation into the control cabinet)
q <sub>W</sub>	W/K	Specific heat output of a heat exchanger
V	m <sup>3</sup> /h	Air flow volume of a filter fan that is required in order to ensure that the maximum temperature difference between the intake and the exiting air is not exceeded
R <sub>Br</sub>	Ω	Braking resistors
R <sub>Br<sub>min</sub></sub>	Ω	Minimum braking resistance
R <sub>Brth</sub>	°C/W	Thermal resistance between braking resistor and the environment
R <sub>th</sub>	°C/W	Thermal resistance
S	VA	Apparent power
t	s	Time (general)
t <sub>Br</sub>	s	Braking time
T <sub>Br<sub>max</sub></sub>	°C	Maximum overtemperature of the resistor
T <sub>imax</sub>	°C	Maximum temperature permitted inside the control cabinet
T <sub>A</sub>	°C	Ambient temperature of the control cabinet
T <sub>cycle</sub>	s	Cycle time
U <sub>DC</sub>	V	DC bus voltage
U <sub>Mains</sub>	V	Supply voltage (phase to phase)

Table 185: Formula variables used



# Chapter 5 • Wiring

---

## 1 General information

### 1.1 Electromagnetic compatibility of the installation

#### 1.1.1 General information

If the directives for electromagnetic compatibility of the installation are followed, ACOPOS servo drives meet EMC directives 2004/108/CE and low-voltage directives 2006/95/CE. They also meet the requirements for harmonized EMC product standard IEC 61800-3:2004 for industrial areas (second environment).

Additional EMC measures must be implemented by the machine or system manufacturer in the event that the product standard for the machine includes lower limit values or the machine conforms to the basic standard IEC 61000-6-4. Additional EMC measures may also be needed for machines with a large number of ACOPOS servo drives. The installation of a central line filter is mostly sufficient in such cases. Proof of conformity to required limit values must be provided by the manufacturer or distributor of the machine or system in accordance with the guidelines for implementing the EMC directive.

Additional EMC measures are required when operating ACOPOS servo drives in a residential area or when connecting ACOPOS servo drives to a low voltage system that also supplies buildings in a residential area (first environment) without an intermediate transformer.

#### 1.1.2 Installation guidelines

1. The control cabinet or system must be constructed properly.
2. To prevent the effects of disturbances, the following lines must be properly shielded:
  - Motor cables
  - Encoder cables
  - Control cables
  - Data cables
3. Inductive switching elements such as contactors or relays must be equipped with corresponding suppressor elements such as varistors, RC elements or damping diodes.
4. All electrical connections must be kept as short as possible.
5. Cable shields must always be attached to designated shield terminals and the plug housing. Twisting the shielding mesh or lengthening cable shields with a single line (pigtail) is not permitted!
6. Shielded cables with copper mesh or tinned copper must be used.
7. Unused cable conductors must be grounded on both sides whenever possible.

The ground connections and shield connections must be made as illustrated in the following diagram:

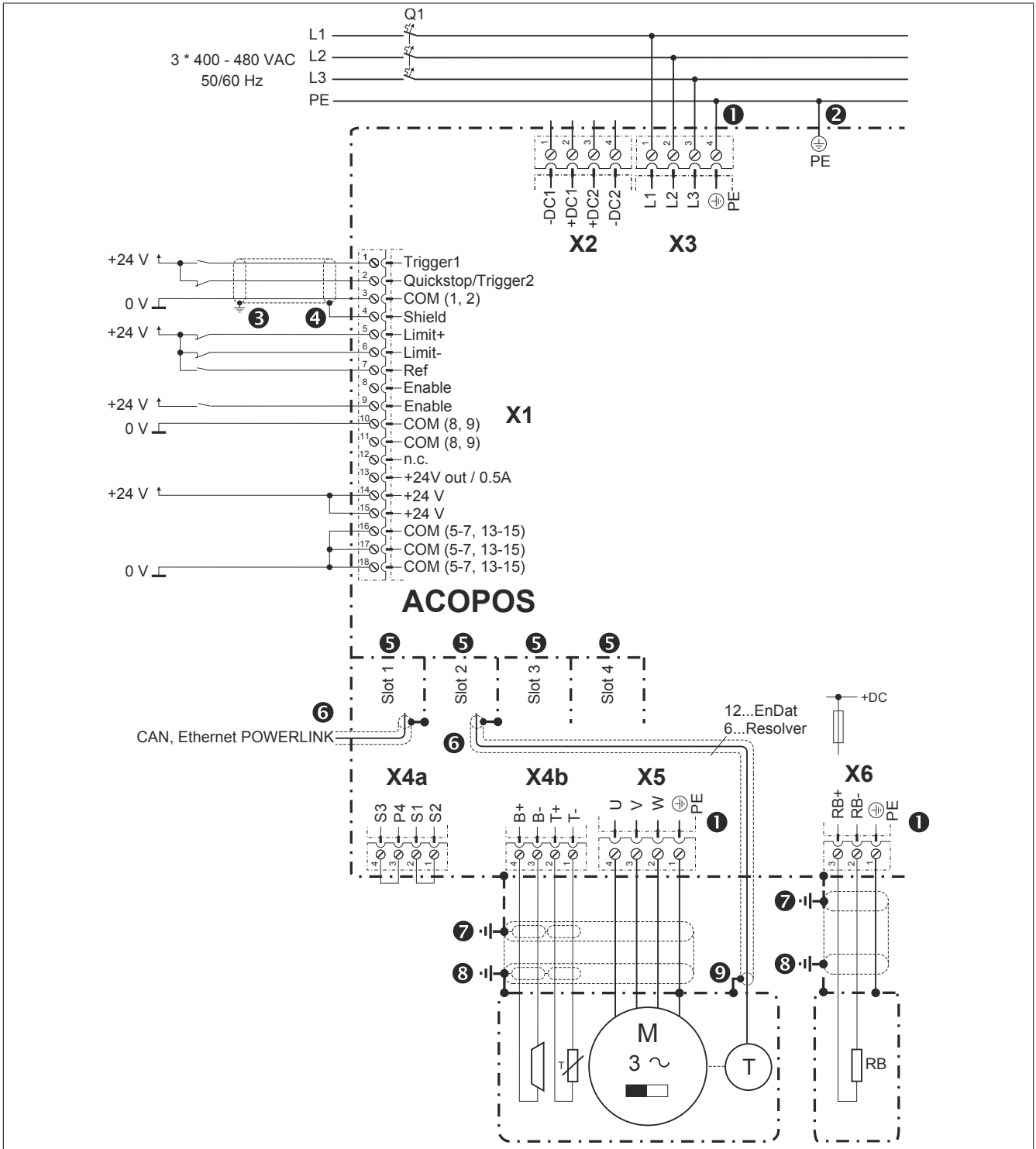


Figure 88: Connection diagram for ground and shield connections

1. The protective ground wires (PE) for the power mains, the motor lines and external braking resistor connection are internally connected to the housing of the ACOPOS servo drive.
2. The second protective ground wire connection is required because of the increased discharge current (3.5 mA) on ACOPOS servo drives 1022, 1045, 1090, 1180 and 1320. The same cross section as the power mains protective ground conductor must be used.
3. Both trigger inputs are only filtered internally with approx. 50  $\mu$ s. Make sure the cable shield is grounded properly.
4. The cable shield must be attached to the shield connector.
5. On all plug-in modules, the two screws used to fasten the module must be tightened so that the mounting bracket is connected to ground.
6. Cable connection via DSUB plug:  
The cable shield must be sufficiently connected using the designated clamp in the metallic or metal-plated DSUB plug housing. The DSUB plug fastening screws must be tightened.

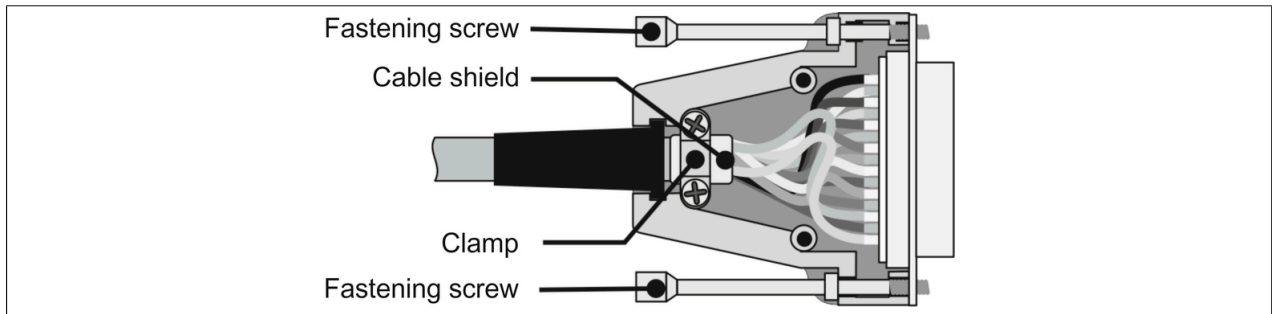


Figure 89: Cable shielding in DSUB housing

Cable connection via terminals:

The cable shield must be attached to the corresponding shield connection terminal.

Cable connection via RJ45 plug:

Grounding the cable shield as well provides an improvement in EMC properties. Grounding should take place on both sides, extensively and near to the connector.

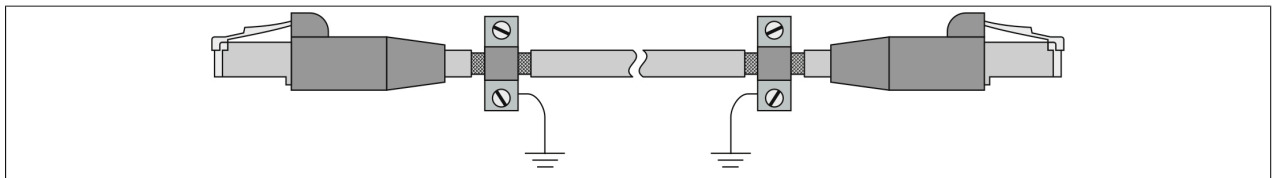


Figure 90: Grounding the POWERLINK cable shielding

**Information:**

When cabling POWERLINK networks with B&R POWERLINK cables, no additional grounding of the cable shield is required to ensure resistance to disturbances in accordance with EN 61800-3!

- The cable shield for the motor line or the connection cable for the external braking resistor is connected with the housing of the ACOPOS servo drive via the grounding plate using the grounding clamp provided:

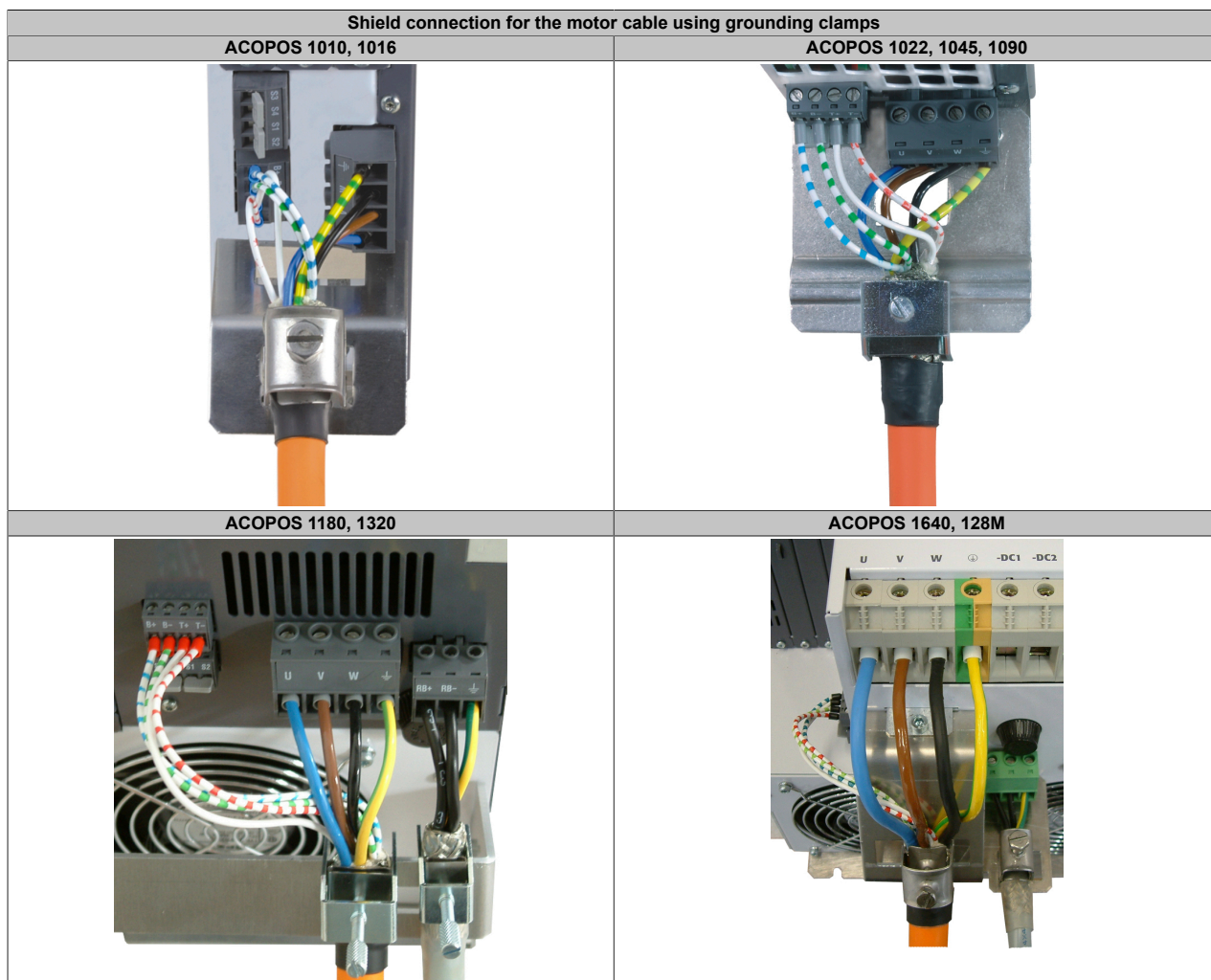


Table 186: Grounding of the motor cable on the ACOPOS servo drive

- On the motor side, the cable shield of the motor line is connected to the motor housing via the motor connector and connected to ground via the machine. The cable shield on the connection cable for the external braking resistor must be connected with the housing of the braking resistor.
- On the motor side, the encoder cable shield must be connected to the motor housing via the encoder connector and connected to ground via the machine.

For external encoders, the cable shield of the encoder cable must be connected (on the encoder side) with the machine and therefore with ground via the encoder connector.

## 1.2 Insulation and high voltage testing

### 1.2.1 Insulation resistance testing in accordance with EN 60204

In accordance with EN 60204, the insulation resistance of electrical equipment is measured with 500 VDC between the main circuit conductors and the protective ground conductor system and is not permitted to be below a value of 1 M $\Omega$ . Testing individual sections of the system is permitted.

#### ACOPOS servo drive power mains connection (X3)

Insulation resistance testing can be carried out on the ACOPOS servo drive power mains connection (X3) as described above; however, values >1 M $\Omega$  are not expected because of the overvoltage protection circuit of the power mains.<sup>25)</sup> The 50 k $\Omega$  minimum value required as specified in EN 60204, Section 18.3 is exceeded anyway.

#### ACOPOS servo drive motor connection (X5)

### Warning!

**Insulation testing is not permitted to be carried out on the ACOPOS servo drive motor connection (X5) because that would destroy the ACOPOS servo drive!**

**The motor cable must be removed from the ACOPOS servo drive motor connection (X5) before measuring the insulation resistance!**

#### B&R motors and B&R motor cables

In principle, an insulation resistance measurement can be carried out on B&R motor cables and B&R motors. However, the insulation resistance can be lower than 1 M $\Omega$  depending on the motor that is connected. The 50 k $\Omega$  minimum value required as specified in EN 60204, Section 18.3 is exceeded anyway.

### Warning!

**Insulation testing is not permitted to be carried out on the ACOPOS servo drive motor connection (X5) because that would destroy the ACOPOS servo drive!**

**The motor cable must be removed from the ACOPOS servo drive motor connection (X5) before measuring the insulation resistance!**

### 1.2.2 High voltage testing

In accordance with EN 60204, the electrical equipment must be able to withstand a test voltage connected between the conductors of all circuits and the protective ground conductor system for at least 1 s (exception: all circuits with a voltage < PELV voltage). The test voltage must be twice the rated voltage for the equipment and at least 1000 VAC (50/60 Hz). Components that cannot handle this test voltage must be disconnected before carrying out the high voltage test.

#### ACOPOS servo drive power mains connection (X3)

### Warning!

**High voltage testing cannot be carried out on the ACOPOS servo drive power mains connection (X3) since arc flashes can occur that are caused by the internal wiring.**

#### ACOPOS servo drive motor connection (X5)

### Warning!

**High voltage testing is not permitted to be carried out on the ACOPOS servo drive motor connection (X5) because it would destroy the ACOPOS servo drive!**

#### B&R motors and B&R motor cables

In principle, high voltage testing can be carried out on B&R motor cables and B&R motors. Depending on the size of the motor and length of the motor cable, increased measurement currents can occur because of capacitive coupling.

<sup>25)</sup> Typical values are: 8V1010/1016: 880 k $\Omega$ ; 8V1022/1045/1090: 820 k $\Omega$ ; 8V1180/1320: 750 k $\Omega$ ; 8V1640/128M: 820 k $\Omega$ .

**Warning!**

High voltage testing is not permitted to be carried out on the ACOPOS servo drive motor connection (X5) because it would destroy the ACOPOS servo drive!

The motor cable must be removed from the ACOPOS servo drive motor connection (X5) before the high voltage measurement!

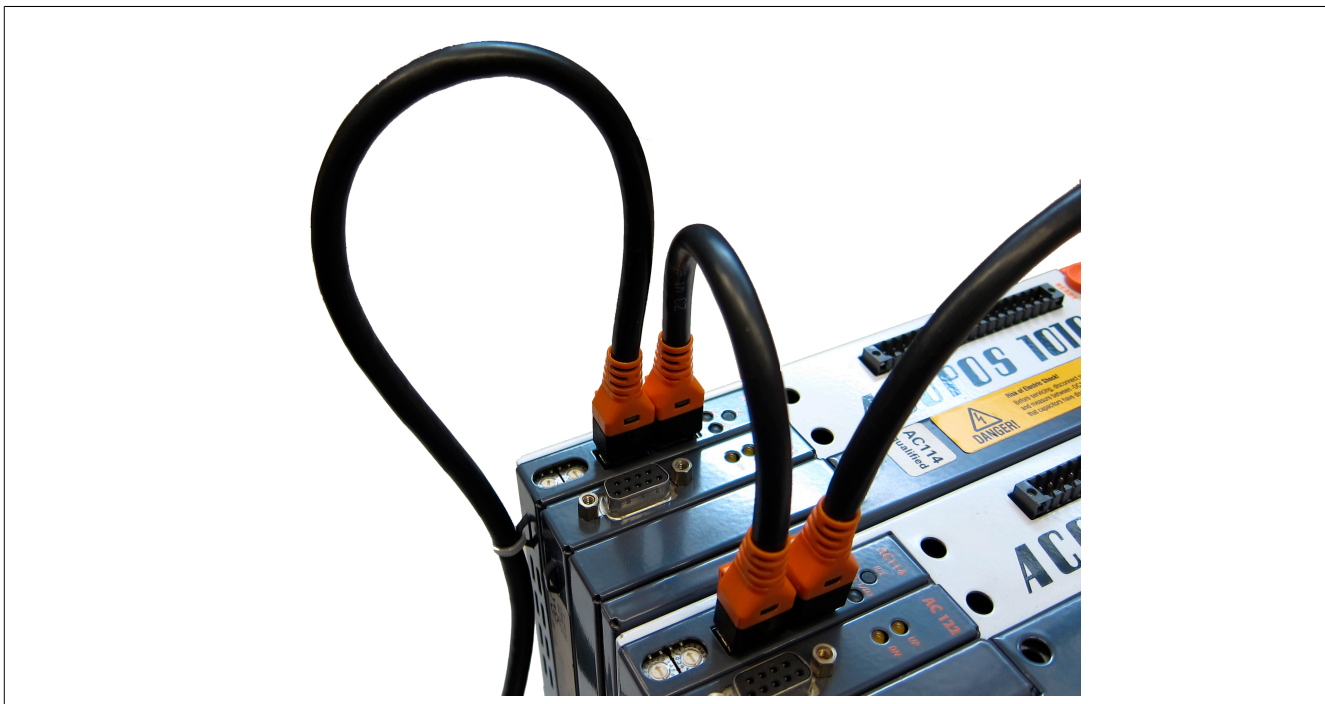
**1.3 Connecting cables to plug-in modules**

Figure 91: Connecting cables to plug-in modules

**Caution!**

When installing plug-in module cables, the minimum permissible flex radius for the cables being used must be taken into consideration during cabling and also when cabling is finished! The minimum permissible flex radius can be found in the documentation for the respective cables.

**Information:**

B&R provides holes for fastening the cables with cable ties on the bottom of the plug-in modules (see image below). This type of fastening is only permitted if the minimum permissible flex radius values for the cables being used are adhered to!

Make sure that the ventilation slots on the bottom of the ACOPOS drive are not blocked.

## 1.4 Overview of clampable cross sections

Con- nection	Wire types Approval data	8V1010.0xx-2 8V1010.5xx-2 8V1016.0xx-2 8V1016.5xx-2		8V1022.0xx-2 8V1045.0xx-2 8V1090.0xx-2 <sup>1)</sup>		8V1180.0xx-2 8V1320.0xx-2 <sup>2)</sup>		8V1640.0xx-2 <sup>3)</sup>		8V128M.0xx-2 <sup>4)</sup>	
		[mm <sup>2</sup> ]	[AWG]	[mm <sup>2</sup> ]	[AWG]	[mm <sup>2</sup> ]	[AWG]	[mm <sup>2</sup> ]	[AWG]	[mm <sup>2</sup> ]	[AWG]
X1	Solid core / multiple-conductor lines	0.5 - 1.5	20 - 14	0.5 - 1.5	20 - 14	0.5 - 1.5	20 - 14	0.5 - 1.5	20 - 14	0.5 - 1.5	20 - 14
	Flexible and fine wire lines Without wire end sleeves	0.5 - 1.5	20 - 14	0.5 - 1.5	20 - 14	0.5 - 1.5	20 - 14	0.5 - 1.5	20 - 14	0.5 - 1.5	20 - 14
	With wire end sleeves	0.5 - 1.5	20 - 14	0.5 - 1.5	20 - 14	0.5 - 1.5	20 - 14	0.5 - 1.5	20 - 14	0.5 - 1.5	20 - 14
	Approval data UL/C-UL-US CSA	---	26 - 14 26 - 14	---	26 - 14 26 - 14	---	26 - 14 26 - 14	---	26 - 14 26 - 14	---	26 - 14 26 - 14
Tightening torque for the terminal screws [Nm]		0.2 ... 0.25		0.2 ... 0.25		0.2 ... 0.25		0.2 ... 0.25		0.2 ... 0.25	
X2 DC bus	Solid core / multiple-conductor lines	0.2 - 4	24 - 10	0.2 - 4	24 - 10	0.5 - 10	20 - 7	10 - 50	7 - 0	16 - 95	6 - 3/0
	Flexible and fine wire lines Without wire end sleeves	0.2 - 4	24 - 10	0.2 - 4	24 - 10	0.5 - 6	20 - 9	10 - 35	7 - 2	10 - 70	7 - 2/0
	With wire end sleeves	0.25 - 4	23 - 10	0.25 - 4	23 - 10	0.5 - 6	20 - 9	10 - 35	7 - 2	10 - 70	7 - 2/0
	Approval data UL/C-UL-US CSA	---	30 - 10 28 - 10	---	30 - 10 28 - 10	---	20 - 8 20 - 8	---	10 - 2 12 - 2	---	6 - 2/0 6 - 2/0
Tightening torque for the terminal screws [Nm]		0.5 ... 0.6		0.5 ... 0.6		1.2 ... 1.5		3 ... 4		6 ... 10	
X3 Mains	Solid core / multiple-conductor lines	0.2 - 4	24 - 10	0.2 - 4	24 - 10	0.5 - 10	20 - 7	10 - 50	7 - 0	16 - 95	6 - 3/0
	Flexible and fine wire lines Without wire end sleeves	0.2 - 4	24 - 10	0.2 - 4	24 - 10	0.5 - 6	20 - 9	10 - 35	7 - 2	10 - 70	7 - 2/0
	With wire end sleeves	0.25 - 4	23 - 10	0.25 - 4	23 - 10	0.5 - 6	20 - 9	10 - 35	7 - 2	10 - 70	7 - 2/0
	Approval data UL/C-UL-US CSA	---	30 - 10 28 - 10	---	30 - 10 28 - 10	---	20 - 8 20 - 8	---	10 - 2 12 - 2	---	6 - 2/0 6 - 2/0
Tightening torque for the terminal screws [Nm]		0.5 ... 0.6		0.5 ... 0.6		1.2 ... 1.5		3 ... 4		6 ... 10	
X4a, X4b Motor (holding brake, tem- perature sensor)	Solid core / multiple-conductor lines	0.2 - 2.5	24 - 12	0.2 - 2.5	24 - 12	0.2 - 2.5	24 - 12	0.2 - 2.5	24 - 12	0.2 - 2.5	24 - 12
	Flexible and fine wire lines Without wire end sleeves	0.2 - 2.5	24 - 12	0.2 - 2.5	24 - 12	0.2 - 2.5	24 - 12	0.2 - 2.5	24 - 12	0.2 - 2.5	24 - 12
	With wire end sleeves	0.25 - 2.5	23 - 12	0.25 - 2.5	23 - 12	0.25 - 2.5	23 - 12	0.25 - 2.5	23 - 12	0.25 - 2.5	23 - 12
	Approval data UL/C-UL-US CSA	---	30 - 12 28 - 12	---	30 - 12 28 - 12	---	30 - 12 28 - 12	---	30 - 12 28 - 12	---	30 - 12 28 - 12
Tightening torque for the terminal screws [Nm]		0.5 ... 0.6		0.5 ... 0.6		0.5 ... 0.6		0.5 ... 0.6		0.5 ... 0.6	
X5 Motor (power)	Solid core / multiple-conductor lines	0.2 - 4	24 - 10	0.2 - 4	24 - 10	0.5 - 10	20 - 7	10 - 50	7 - 0	16 - 95	6 - 3/0
	Flexible and fine wire lines Without wire end sleeves	0.2 - 4	24 - 10	0.2 - 4	24 - 10	0.5 - 6	20 - 9	10 - 35	7 - 2	10 - 70	7 - 2/0
	With wire end sleeves	0.25 - 4	23 - 10	0.25 - 4	23 - 10	0.5 - 6	20 - 9	10 - 35	7 - 2	10 - 70	7 - 2/0
	Approval data UL/C-UL-US CSA	---	30 - 10 28 - 10	---	30 - 10 28 - 10	---	20 - 8 20 - 8	---	10 - 2 10 - 2	---	6 - 2/0 6 - 2/0
Tightening torque for the terminal screws [Nm]		0.5 ... 0.6		0.5 ... 0.6		1.2 ... 1.5		3 ... 4		6 ... 10	
X6 External braking resistor	Solid core / multiple-conductor lines	---	---	---	---	0.2 - 4	24 - 10	0.5 - 10	20 - 7	0.5 - 10	20 - 7
	Flexible and fine wire lines Without wire end sleeves	---	---	---	---	0.2 - 4	24 - 10	0.5 - 6	20 - 9	0.5 - 6	20 - 9
	With wire end sleeves	---	---	---	---	0.25 - 4	23 - 10	0.5 - 6	20 - 9	0.5 - 6	20 - 9
	Approval data UL/C-UL-US CSA	---	---	---	---	---	30 - 10 28 - 10	---	20 - 8 20 - 8	---	20 - 8 20 - 8
Tightening torque for the terminal screws [Nm]		---		---		0.5 ... 0.6		1.2 ... 1.5		1.2 ... 1.5	

Table 187: Terminal cross sections for ACOPOS servo drives

- 1) Starting with revision I0.
- 2) Starting with revision F0.
- 3) Starting with revision K0.
- 4) Starting with revision C0.



# Chapter 6 • Safety technology

## 1 Standard safety technology ("Wired safety technology")

### Danger!

Especially in the area of safety technology, always consult the latest version of the User's Manual on the B&R website ([www.br-automation.com](http://www.br-automation.com)) for the valid specifications. Specifications in this version of the user's manual are not necessarily current. Users should verify the correctness of specifications before implementing any safety functions.

### 1.1 General information

ACOPOS servo drives use integrated safe pulse disabling for secure shutdown and to prevent unwanted startup. This is designed to meet the following safety classifications depending on the external circuit: <sup>26)</sup>

Criteria	Safety characteristic
Maximum Safety Category in accordance with EN ISO 13849 and EN 954-1 <sup>1)</sup>	CAT 3
Maximum Performance Level in accordance with EN ISO 13849	PL d
Maximum Safety Integrity Level in accordance with IEC 62061	SIL 2
Maximum Safety Integrity Level in accordance with IEC 61508	SIL 2
PFH (probability of dangerous failure per hour)	$<4 * 10^{-9}$
PFD (probability of dangerous failure on demand)	$<4 * 10^{-4}$ with a proof test interval of 10 years $<7 * 10^{-5}$ with a proof test interval of 20 years
PTI (proof test interval) <sup>2)</sup>	Max. 20 years
DC (diagnostic coverage)	99%
MTTFd (mean time to dangerous failure)	$>140$ years

Table 188: Safety classifications, criteria and characteristics for safe pulse disabling

- 1) EN 954-1 is no longer valid and has been replaced by EN ISO 13849.
- 2) Corresponds to the mission time of the module

The following table provides an overview of the individual safety functions that can be implemented:

Label according to standard		Short description
EN 61800-5-2	EN 60204-1	
STO (Safe Torque Off)	Stop Category 0	Power supply cutoff
SS1 (Safe Stop 1)	Stop Category 1	Initiates active braking and activation of the STO function after a defined amount of time has passed
SS2 (Safe Stop 2)	Stop Category 2	Initiates active braking and activation of the SOS function after a defined amount of time has passed
SLS (Safely Limited Speed)	---	Protection against exceeding a defined speed limit
SOS (Safe Operating Stop)	---	Protection against impermissible position deviation

Table 189: Overview of safety functions according to standards

Safe pulse disabling interrupts the power supply to the motor by preventing the pulses to the IGBTs over one channel. In this way, a rotating field can no longer be created in synchronous and induction motors controlled by ACOPOS servo drives.

Integrated safe pulse disabling therefore meets the requirements for preventing unexpected startup in accordance with EN 1037 as well as the requirements concerning Category 0 and 1 stop functions in accordance with EN 60204-1. Both stop functions require the supply to the machine drives to be switched off (immediately for Category 0 and after reaching standstill for Category 1). The requirements concerning the STO, SS1, SS2, SLS and SOS safety functions are also met in accordance with EN 61800-5-2.

The terminology of EN 61800-5-2 (STO, SS1, SS2, SLS, SOS) will be used in the following.

### Danger!

If an application uses the safety functions integrated in the drive system, then the safety functions must be fully validated before being turned on for the first time. This could lead to death, severe injury or damage to equipment.

<sup>26)</sup> A detailed explanation of the standards and safety functions can be found in the section "Standards and Certifications".

## 1.2 Principle - Implementing the safety function

Safe pulse disabling is achieved by removing the IGBT driver supply from the ACOPOS servo drives. Terminals X1 / Enable and X1 / COM (8, 9) are used to supply an integrated DC-to-DC converter with 24 VDC. The converter creates the supply voltage for the IGBT driver from this voltage.

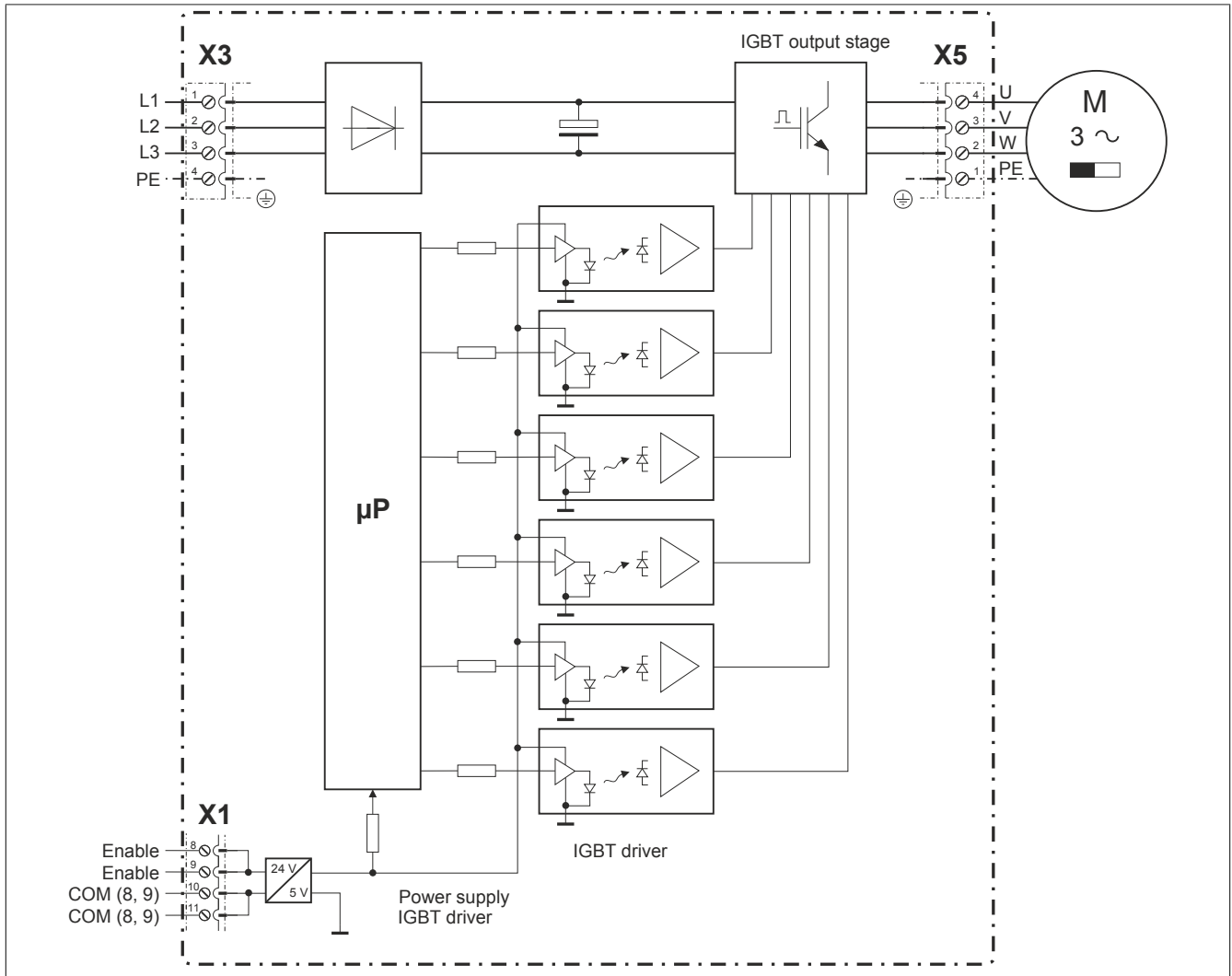


Figure 92: Block diagram of safe pulse disabling

If the 24 VDC voltage supply for the DC-to-DC converter is interrupted, the IGBT drivers are also no longer supplied. It is then no longer possible to transfer the modulation pattern needed to generate the rotating field on the IGBT output stage. This cuts off the supply of power to the motor.

### 1.2.1 Additional function

The availability of the DC-to-DC converter's output voltage is queried by the microprocessor. If voltage is not present on the output of the DC-to-DC converter, then the microprocessor suppresses generation of the modulation pattern.

#### **Danger!**

After activating safe pulse disabling using terminals X1 / Enable and X1/COM (8, 9), the motor is de-energized and therefore torque-free. If the motor was moving before activation of safe pulse disabling, it is only stopped by a safe operational brake (available under certain conditions) or from the friction of the entire system. The motor is therefore not able to hold hanging loads. Holding brakes must be used for this purpose.

For applications where this can be dangerous, the desired level of protection cannot be achieved.

#### **Danger!**

The switch-off time for the enable input must be taken into consideration since it has a substantial effect on the response time of the safety functions and therefore the remaining distances and times to be considered. In order to calculate the total safety response time, the user must validate the lag time throughout the entire system.

The switch-off times for the enable input can be found in the technical data for the respective ACOPOS servo drive.

#### **Danger!**

Activating safe pulse disabling via the terminals X1 / Enable1 and X1/COM (8, 9) is not sufficient for achieving a voltage-free drive and therefore does not provide sufficient protection against electrical shock!

#### **Danger!**

Depending on the application, it is possible for the drive to restart after safe pulse disabling is deactivated.

#### **Danger!**

The brake controller integrated in ACOPOS servo drives and the holding brake integrated in B&R standard motors fulfill the criteria up to Category B in accordance with EN ISO 13849-1.

Additional measures are necessary to achieve higher safety categories.

#### **Danger!**

The C standards applicable to applications must be adhered to!

#### **Information:**

Note that multiple errors in the IGBT bridge can cause a brief forward movement. The maximum turning angle of the motor shaft  $\varphi$  during this forward movement depends on the motor being used. For permanently excited synchronous motors,  $\varphi = 360^\circ/2p$  (for B&R standard motors,  $p=3$  so the angle is  $60^\circ$ ). For three-phase induction motors, there is a relatively small angle of rotation (between  $5^\circ$  and  $15^\circ$ ).

This short forward movement can be ruled out as an error in accordance with EN ISO 13849-1, among other things due to the improbability that this would occur and due to general technical experience.

### 1.3 Enable input connected in accordance with Safety Category 3 / SIL 2 / PL d

Using the example of the STO safety function, different circuit variations for the enable input on the ACOPOS servo drives are given here with regard to the required Safety Category / SIL / PL.

#### Danger!

All errors (e.g. cross faults) that are not detected can lead to a loss of safety functionality.

Suitable measures that can ensure the exclusion of the error must be taken. In accordance with EN ISO 13849-2, Appendix D.5, errors caused by short circuit between any two conductors

- that are permanently installed and protected against external damage (e.g. using a cable duct or armored conduit)
- in different sheathed cables
- within an area for electrical equipment <sup>27)</sup>
- that are each individually protected via ground connection

can be considered excluded. <sup>28)</sup>

#### Danger!

To achieve Safety Category 3 / SIL 2 / PL d, it must be ensured that a single error does not lead to a loss of safety functionality.

#### 1.3.1 STO, Category 3 / SIL 2 / PL d (Variant A)

The input X1 / Enable and X1 / COM (8, 9) of the ACOPOS servo drive are supplied via a safe digital output (Out1+, Out1-). If the safety function is requested, then the safe digital output separates input X1 / Enable and X1 / COM (8, 9).

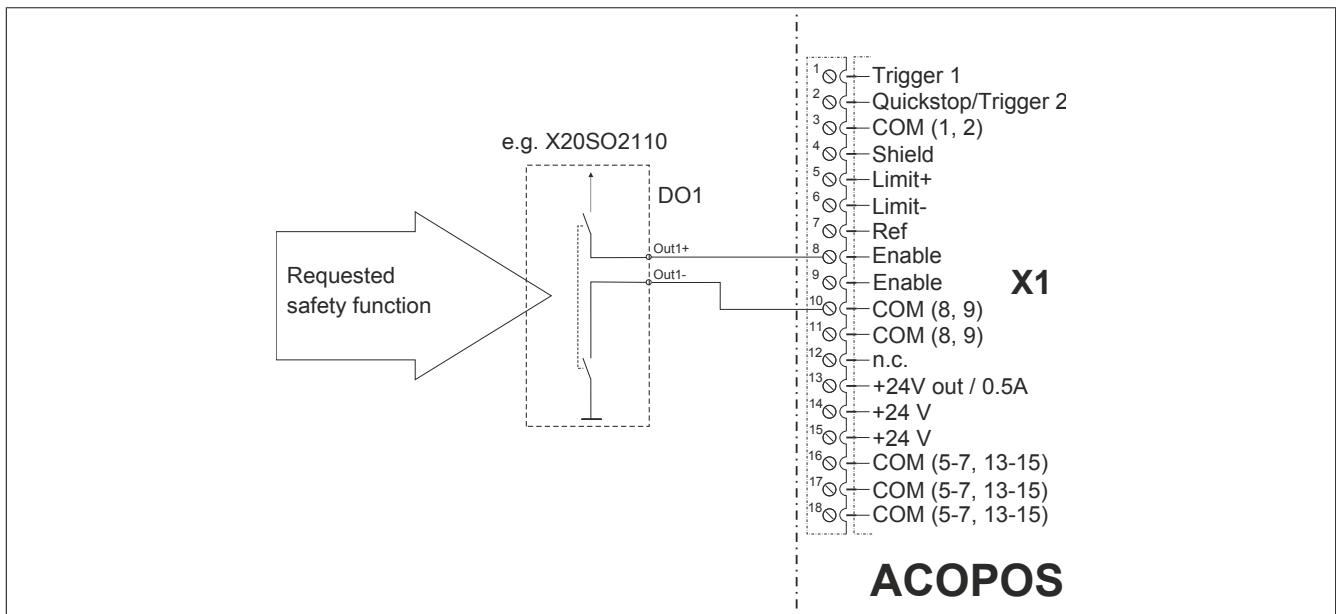


Figure 93: STO, Category 3 / SIL 2 / PL d (Variant A)

#### Danger!

At least one safe digital output module with Category 3 / SIL 2 / PL d must be used for the DO1 digital output shown.

The guidelines listed in the safe digital output module's user documentation must be observed!

Test signals on the safe digital output module must be turned off.

<sup>27)</sup> Both the wires and the area for electrical equipment must meet applicable requirements (see IEC 60204-1).

<sup>28)</sup> For more error exclusions, see EN ISO 13849-2, Appendix D.5.

### 1.3.2 STO, Category 3 / SIL 2 / PL d (Variant B)

When an E-stop button is pressed, the enable input on the ACOPOS servo drive is cut off from the +24 V supply by a switch, thereby cutting off the motor's power supply.

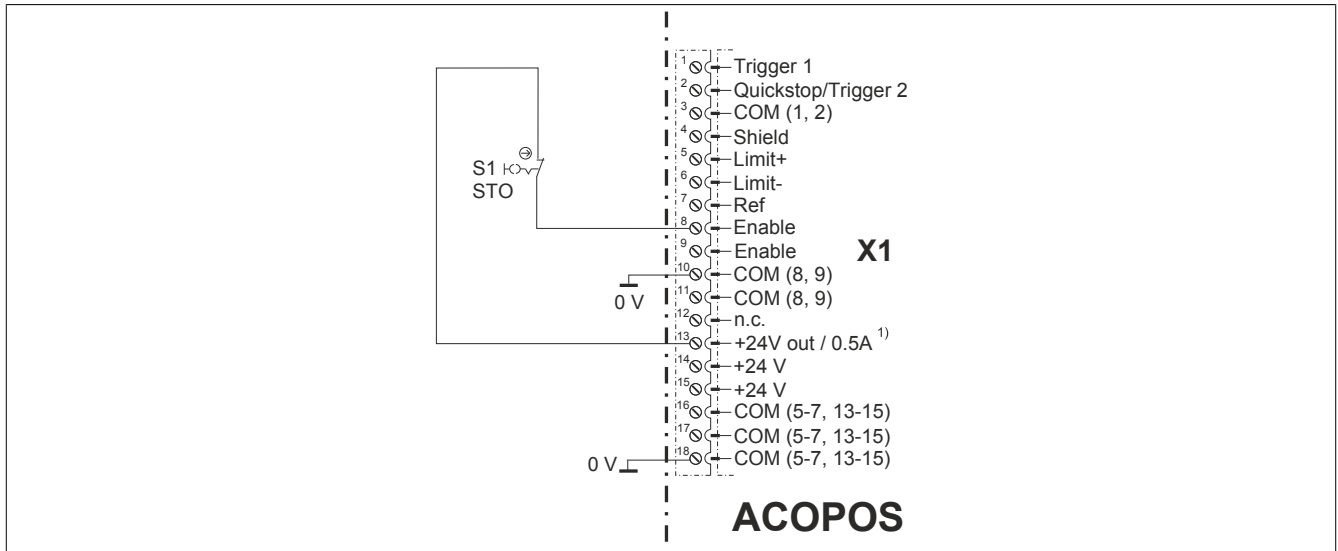


Figure 94: STO, Category 3 / SIL 2 / PL d (Variant B)

1) For servo drives which have no 24 VDC output (ACOPOS 1010/1016/1022/1045/1090), the control voltage must be provided externally.

## Danger!

The S1 switch shown requires the use of a one-pin Category 3 / SIL 2 / PL d switching device with a positively-driven NC contact in accordance with EN 60947-5-1.

The guidelines in the switching device's user documentation must be observed!

### 1.4 Enable input circuits in accordance with Safety Category 3 / SIL 2 / PL d and functionality (STO, SS1, SS2, SLS, SOS)

The following image illustrates example wiring suggestions for the external wiring of the enable input on ACOPOS servo drives. They vary in their safety classification in accordance with EN 60204-1, ISO 13849 and EN 61800-5-2 as well as with regard to the safety function (STO, SS1, SS2, SLS, SOS).

#### 1.4.1 STO, SLS, SOS - Safety Category 3 / SIL 2 / PL d

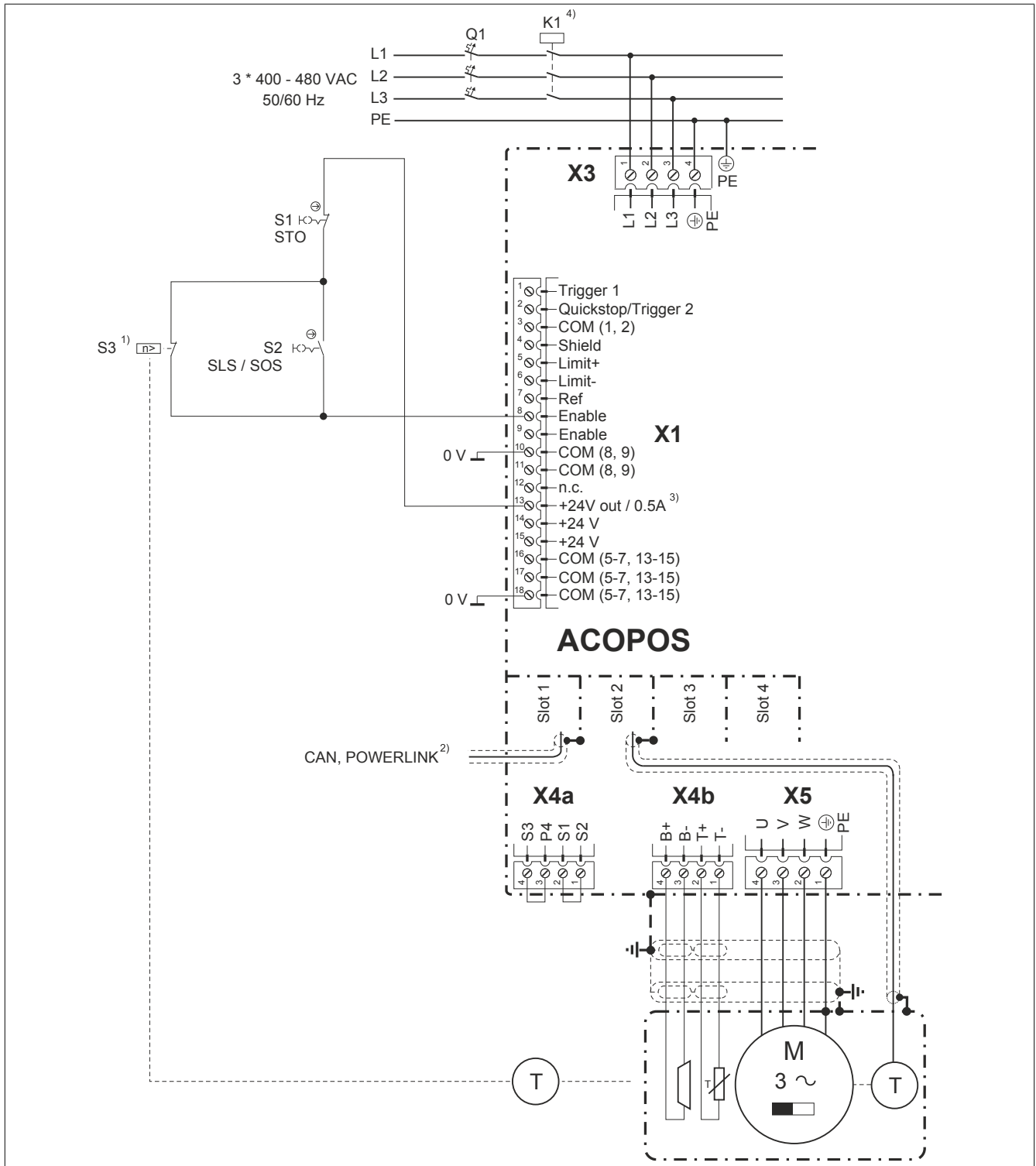


Figure 95: STO, SLS, SOS - Safety Category 3 / SIL 2 / PL d

- 1) S3 limit speed according to the application requirements.  
S3 including the encoder is part of the safety function.  
Implementation of S3 including the encoder must therefore meet Category 3 / SIL 2 / PL d.
- 2) The network connection is used for diagnostics and setting parameters.
- 3) For servo drives which have no 24 VDC output (ACOPOS 1010/1016/1022/1045/1090), the control voltage must be provided externally.
- 4) The K1 line contactor is not required for the safety function.

## Danger!

The brake shown in this image as well as the brake control from the ACOPOS servo drive are not included in the safety function!

### Description:

#### STO

When the S1 E-stop button is pressed, the enable input on the ACOPOS servo drive is de-energized. As a result, the supply of power to the motor is cut off.

This ensures that the supply of power to the motor is always cut off immediately.

#### Secure restart inhibit

Opening and locking the S1 E-stop switch prevents unexpected startup.

#### SLS

Opening the S2 switch activates the SLS safety function. The switching contact of the S3 overspeed monitor is opened if the monitor's configured speed limit is exceeded. This de-energizes the enable input of the ACOPOS servo drive. As a result, the supply of power to the motor is cut off.

This ensures that the supply of power to the motor is always cut off immediately when the speed limit set on the S3 overspeed monitor is exceeded.

#### SOS

Opening the S2 switch activates the SOS safety function. The switching contact of the overspeed monitor is opened when the S3 standstill monitor is activated. This de-energizes the enable input of the ACOPOS servo drive. As a result, the supply of power to the motor is cut off.

This ensures that the supply of power to the motor is always cut off immediately when the S3 standstill monitor is activated.

### Information:

The SLS or SOS safety function can be implemented depending on the function of the S3 switching device (overspeed monitor or standstill monitor).

## Danger!

The S1 and S2 switches shown require the use of one-pin Category 3 / SIL 2 / PL d switching devices with a positively-driven NC contact in accordance with EN 60947-5-1. A one-pin Category 3 / SIL 2 / PL d switching device must be used for the S3 switching device shown.

The guidelines in the switching device's user documentation must be observed!

1.4.2 SS1, SLS, SS2 - Safety Category 3 / SIL 2 / PL d (Variant A)

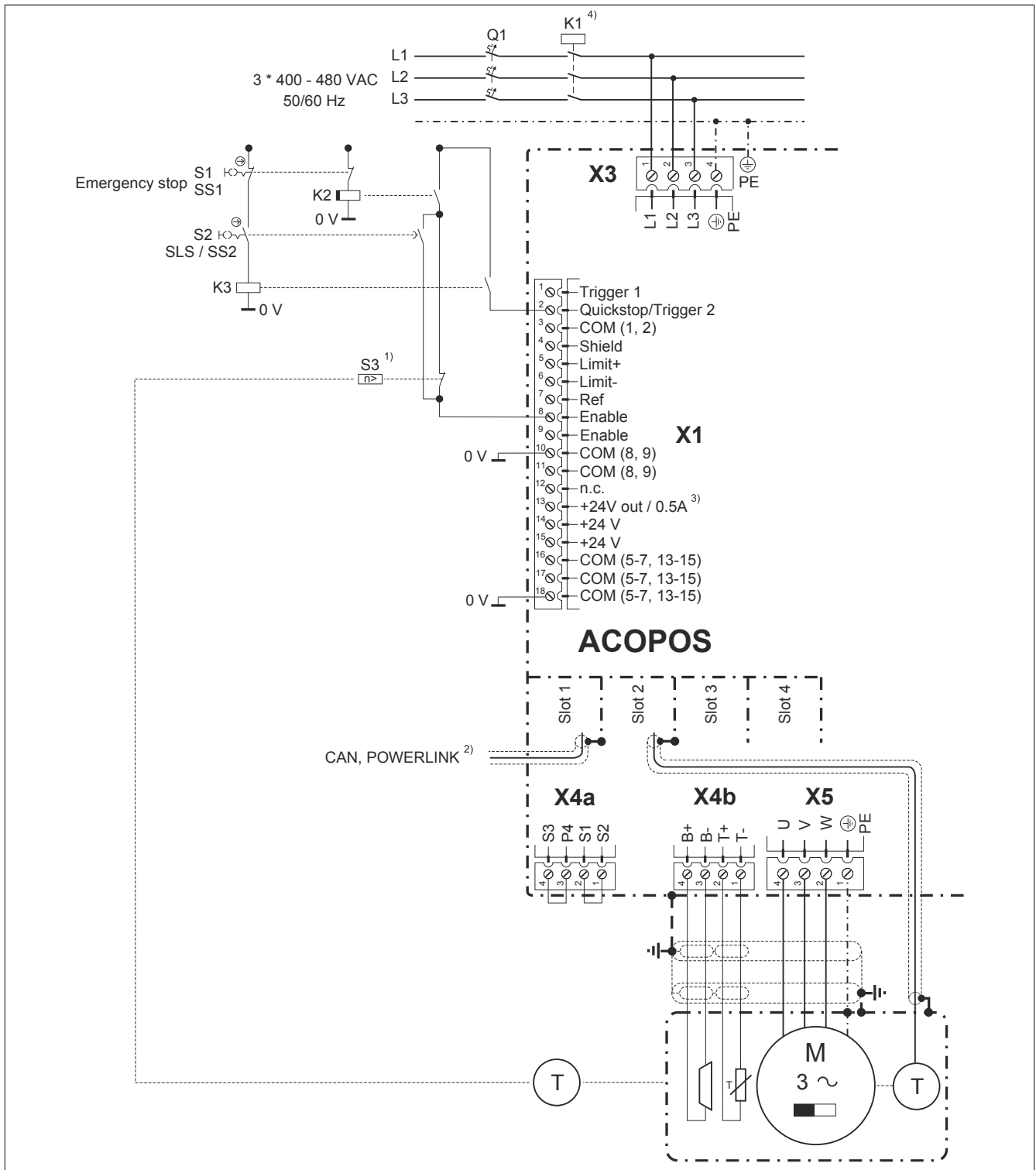


Figure 96: SS1, SLS, SS2 - Safety Category 3 / SIL 2 / PL d (Variant A)

- 1) S3 limit speed according to the application requirements. S3 including the encoder is part of the safety function. Implementation of S3 including the encoder must therefore meet Category 3 / SIL 2 / PL d.
- 2) The network connection is used for diagnostics and setting parameters.
- 3) For servo drives which have no 24 VDC output (ACOPOS 1010/1016/1022/1045/1090), the control voltage must be provided externally.
- 4) The K1 line contactor is not required for the safety function.

**Danger!**

The brake shown in this image as well as the brake control from the ACOPOS servo drive are not included in the safety function!

**Information:**

For this circuit, the input X1 / Quickstop / Trigger 2 of the ACOPOS servo drive must be configured as a quickstop for this connection.

**Description:****SS1**

Pressing the S1 E-stop button de-energizes the K3 relay. As a result, an active braking procedure is triggered via the X1 / Quickstop / Trigger2 input of the ACOPOS servo drive.

The K2 auxiliary drop-out delay relay is de-energized after a defined amount of time. This de-energizes the enable input of the ACOPOS servo drive. As a result, the supply of power to the motor is cut off.

This ensures that the supply of power to the motor is always cut off after a defined amount of time.

**Secure restart inhibit**

Opening and locking the S1 E-stop switch prevents unexpected startup.

**SLS**

When the S2 switch is opened, the SLS safety function is activated and triggers an active braking procedure via the X1 / Trigger1 input on the ACOPOS servo drive. After a defined amount of time, speed monitoring is activated on the S3 overspeed monitor. If the defined limit speed is exceeded, then the enable input of the ACOPOS servo drive is de-energized via the switching contact of the S3 overspeed monitor. As a result, the supply of power to the motor is cut off.

This ensures that the supply of power to the motor is always cut off immediately when the speed limit set on the S3 overspeed monitor is exceeded.

**SS2**

When the S2 switch is opened, the SS2 safety function is activated and triggers an active braking procedure via the X1 / Trigger1 input on the ACOPOS servo drive. After a defined amount of time, standstill monitoring is activated on the S3 standstill monitor. If the defined tolerance limit is exceeded (standstill monitor S3 is activated), then the enable input of the ACOPOS servo drive is cleared via the switching contact of the standstill monitor S3. As a result, the supply of power to the motor is cut off.

This ensures that the supply of power to the motor is always cut off immediately when the S3 standstill monitor is activated.

**Information:**

Either the SLS or the SS2 safety function can be implemented depending on the function of the S3 switching device (overspeed monitor or standstill monitor).

**Danger!**

The S1 and S2 switches shown require the use of one-pin Category 3 / SIL 2 / PL d switching devices with a positively-driven NC contact in accordance with EN 60947-5-1. A one-pin Category 3 / SIL 2 / PL d switching device must be used for the K2 relay shown as well as the S3 switching device.

The instructions in the switching device's user documentation must be observed!

1.4.3 SS1, SLS, SS2 - Safety Category 3 / SIL 2 / PL d (Variant B)

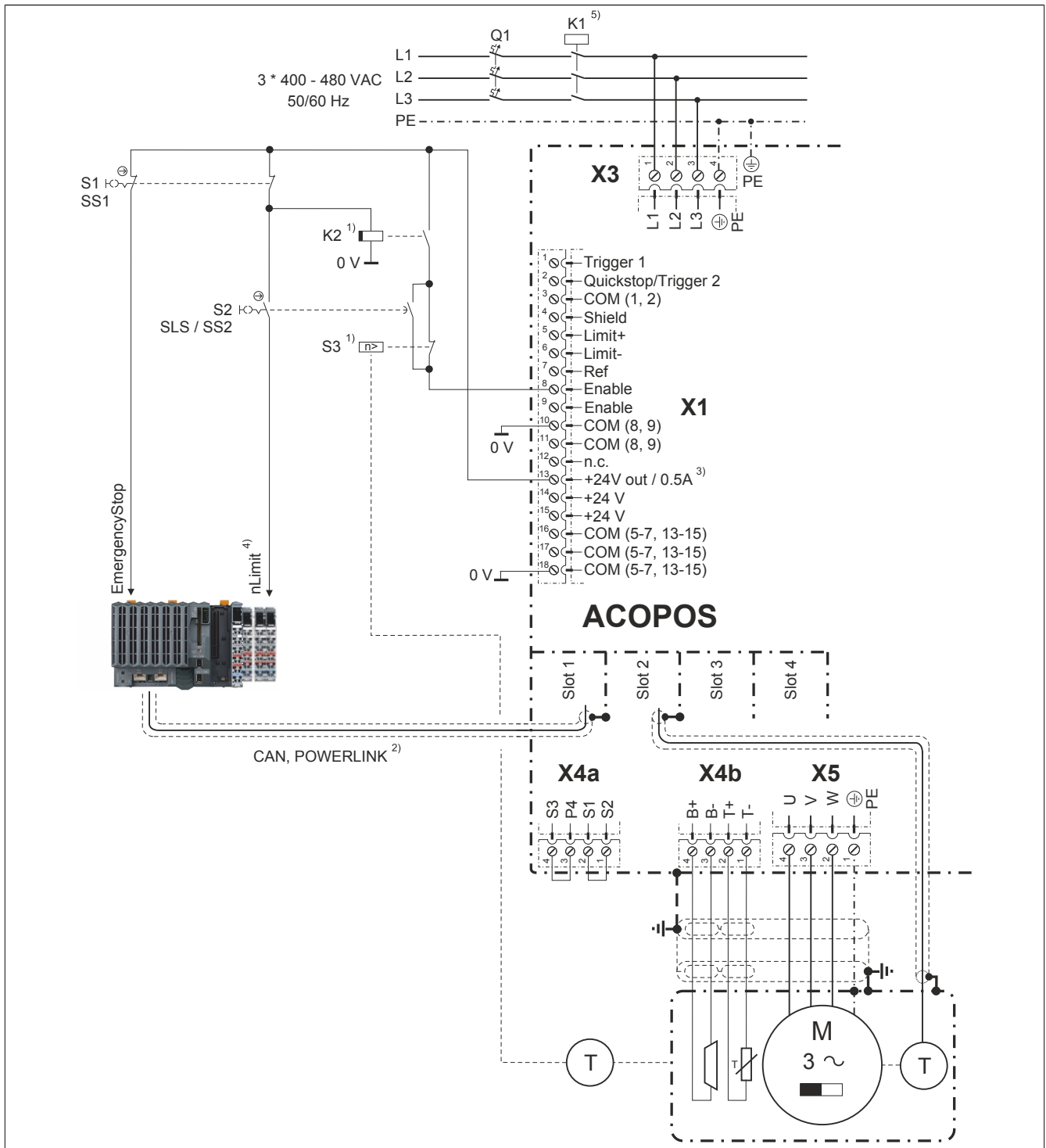


Figure 97: SS1, SLS, SS2 - Safety Category 3 / SIL 2 / PL d (Variant B)

- 1) K2 dropout delay and S3 limit speed according to the application requirements.  
The K2 auxiliary drop-out delay relay and the S3 (including the encoder) are part of the safety function. The implementation of K2 and S3 including the encoder must therefore meet the requirements of Category 3 / SIL 2 / PL d.
- 2) The network connection is used to transfer the interruption command for active braking, diagnostics and setting parameters.
- 3) For servo drives which have no 24 VDC output (ACOPOS 1010/1016/1022/1045/1090), the control voltage must be provided externally.
- 4) Information about the status of the "EmergencyStop" digital input is also contained in the status of the "nLimit" digital input.
- 5) The K1 line contactor is not required for the safety function.

**Danger!**

The brake shown in this image as well as brake control from the ACOPOS servo drive are not included in the safety function!

**Description:****SS1**

When the S1 E-stop switch is pressed, the "EmergencyStop" digital input on the controller triggers an active braking procedure (see "Code example" on page 258).

The K2 auxiliary drop-out delay relay is de-energized after a defined amount of time. This de-energizes the enable input of the ACOPOS servo drive. As a result, the supply of power to the motor is cut off.

This ensures that the supply of power to the motor is always cut off after a defined amount of time.

**Secure restart inhibit**

Opening and locking the S1 E-stop switch prevents unexpected startup.

**SLS**

When the S2 switch is opened, the SLS safety function is activated and triggers an active braking procedure via the "nLimit" digital input on the controller (see "Code example" on page 258). After a defined amount of time, speed monitoring is activated on the S3 overspeed monitor. If the defined limit speed is exceeded, then the enable input of the ACOPOS servo drive is de-energized via the switching contact of the S3 overspeed monitor. As a result, the supply of power to the motor is cut off.

This ensures that the supply of power to the motor is always cut off immediately when the speed limit set on the S3 overspeed monitor is exceeded.

**SS2**

When the S2 switch is opened, the SS2 safety function is activated and triggers an active braking procedure via the "nLimit" digital input on the controller (see "Code example" on page 258). After a defined amount of time, standstill monitoring is activated on the S3 standstill monitor. If the defined tolerance limit is exceeded (standstill monitor S3 is activated), then the enable input of the ACOPOS servo drive is cleared via the switching contact of the standstill monitor S3. As a result, the supply of power to the motor is cut off.

This ensures that the supply of power to the motor is always cut off immediately when the S3 standstill monitor is activated.

**Information:**

Either the SLS or the SS2 safety function can be implemented depending on the function of the S3 switching device (overspeed monitor or standstill monitor).

**Danger!**

The S1 and S2 switches shown require the use of two or one-pin switching devices (Category 3 / SIL 2 / PL d) with a positively driven NC contact in accordance with EN 60947-5-1. A one-pin Category 3 / SIL 2 / PL d switching device must be used for the K2 relay shown as well as the S3 switching device.

The instructions in the switching device's user documentation must be observed!

**Code example**

Issuing the stop command (via CAN bus or POWERLINK):

```

if ( ! stop_active )
{
/* Movement stop not active: Test stop inputs */
if ( EmergencyStop == ncLOW )
{
/* Activate movement stop with parameter set for "emergency stop" */
stop_index = E_STOP_INDEX;
step = MOV_STOP;
stop_active = 1;
}
else
{
/* Activate movement stop with parameter set for "low speed" */
stop_index = NLIMIT_INDEX;
step = MOV_STOP;
stop_active = 1;
}
}
else
{
/* Movement stop was activated */
if ( EmergencyStop == ncHIGH && nLimit == ncHIGH
&& step!= W_MOVE_STOP )
{
/* Movement stop completed */
stop_active = 0;
}
}

switch (step)
{
...
case MOV_STOP:
/* Call NC action for movement stop */
p_ax_dat->move.stop.index.command = stop_index;

action_status = naction(ax_obj,ncMOVE,ncSTOP);
if ( action_status == ncOK )
{
step = W_MOVE_STOP;
}
break;

case W_MOVE_STOP:
/* Wait for movement stop procedure to complete */
if ( p_ax_dat->move.mode == ncOFF )
{
/* Movement stop completed */
step = <NEXT_STEP>
}
break;
...
}

```

# Chapter 7 • Standards and certifications

## 1 Applicable European directives

- EMC directive 2004/108/CE
- Low-voltage directive 2006/95/CE
- Machine guideline 2006/42/EC<sup>29)</sup>

## 2 Applicable standards

Standard	Description
IEC/EN 61800-2	Adjustable speed electrical power drive systems <ul style="list-style-type: none"> <li>• Part 2: General requirements; Rating specifications for low voltage adjustable frequency AC power drive systems</li> </ul>
IEC/EN 61800-3	Adjustable speed electrical power drive systems <ul style="list-style-type: none"> <li>• Part 3: EMC requirements including specific test methods</li> </ul>
IEC 61800-5-1	Electrical drive systems with adjustable speed <ul style="list-style-type: none"> <li>• Part 5-1: Safety requirements - Electrical, thermal and power requirements (IEC 61800-5-1:2003)</li> </ul>
EN 61800-5-2	Adjustable speed electrical power drive systems <ul style="list-style-type: none"> <li>• Part 5-2: Safety requirements - Functional requirements</li> </ul>
IEC/EN 61131-2	Programmable logic controllers <ul style="list-style-type: none"> <li>• Part 2: Equipment requirements and tests</li> </ul>
EN 60204-1	Safety of machinery - Electrical equipment on machines <ul style="list-style-type: none"> <li>• Part 1: General requirements</li> </ul>
IEC 61508	Functional safety of electrical / electronic / programmable electronic safety-related systems
EN 50178-1	Electronic equipment for high voltage systems
EN 1037	Safety of machinery - Prevention of unexpected startup
EN 954-1 <sup>1)</sup>	Safety of machinery - Safety-related parts of control systems <ul style="list-style-type: none"> <li>• Part 1: General design principles</li> </ul>
EN ISO 13849-1	Safety of machinery - Safety-related parts of control systems <ul style="list-style-type: none"> <li>• Part 1: General design principles</li> </ul>
EN 62061	Safety of machinery - Functional safety of safety-related electrical, electronic and programmable electronic control systems
UL 508C	Power conversion equipment

Table 190: Applicable standards for ACOPOS servo drives

1) Replaced by EN ISO 13849-1.

The limit values specified from section "Environmental limits" to section "Other environmental limit values in accordance with IEC 61800-2" are taken from the product standard EN 61800 (or IEC 61800) for servo drives in industrial environments (category C3<sup>30)</sup>). Stricter test procedures and limit values are used during the type tests for ACOPOS servo drives. Additional information is available from B&R.

<sup>29)</sup> This machine directive only applies to logic units for safety functions that are initially being placed on the market by B&R for sale or use.

<sup>30)</sup> Limit values from CISPR11, Group 2, Class A (second environment)

### 3 Environmental limits

#### 3.1 Mechanical conditions in accordance with IEC 61800-2

##### 3.1.1 Operation

IEC 60721-3-3, class 3M1	
	EN 61800-2
Vibration during operation 2 ≤ f < 9 Hz 9 ≤ f < 200 Hz	0.3 mm amplitude 1 m/s <sup>2</sup> acceleration

Table 191: Mechanical conditions during operation

##### 3.1.2 Transport

IEC 60721-3-2, class 2M1	
	EN 61800-2
Vibration during transport 2 ≤ f < 9 Hz 9 ≤ f < 200 Hz 200 ≤ f < 500 Hz	3.5 mm amplitude 10 m/s <sup>2</sup> acceleration 15 m/s <sup>2</sup> acceleration

Table 192: Mechanical conditions during transport

#### 3.2 Climate conditions in accordance with IEC 61800-2

##### 3.2.1 Operation

IEC 60721-3-3, class 3K3	
	EN 61800-2
Ambient temperature during operation	5 to 40°C
Relative humidity during operation	5 - 85%, non-condensing

Table 193: Climate conditions during operation

##### 3.2.2 Storage

IEC 60721-3-1, class 1K4	
	EN 61800-2
Storage temperature	-25 to +55°C

Table 194: Climate conditions (temperature) during storage

IEC 60721-3-1, class 1K3	
	EN 61800-2
Relative humidity during storage	5 - 95%, non-condensing

Table 195: Climate conditions (humidity) during storage

##### 3.2.3 Transport

IEC 60721-3-2, class 2K3	
	EN 61800-2
Transport temperature	-25 to +70°C
Relative humidity during transport	Max. 95% at +40°C

Table 196: Climate conditions during transport

## 4 Requirements for immunity to disturbances (EMC)

EN 61800-3 requirements apply.

### 4.1 Evaluation criteria (performance criteria)

Performance criteria (PC)	Description
A	The test object is not interfered with during testing.
B	The test object is only interfered with temporarily during testing.
C	The system does not reboot itself automatically (reset required).

Table 197: Evaluation criteria (performance criteria) for immunity to disturbances

### 4.2 Low-frequency disturbances in accordance with IEC 61800-3

The following limit values are applicable for industrial environments (category C3).<sup>31)</sup>

#### 4.2.1 Power mains harmonics and commutation notches / voltage distortions

IEC 61000-2-4, class 3		
	EN 61800-3	Performance criteria
Harmonics	THD = 10%	A
Short harmonics (<15 s)	1.5x continuous level	B

Table 198: Limit values for power mains harmonics

IEC 60146-1-1, class 3		
	EN 61800-3	Performance criteria
Commutation notches	Depth = 40%, Total area = 250% x degree	A

Table 199: Limit values for commutation notches / voltage distortions

#### 4.2.2 Voltage changes, fluctuations, dips and short-term interruptions

IEC 61000-2-4, class 3		
	EN 61800-3	Performance criteria
Voltage changes and fluctuations	±10%	A
Voltage changes and fluctuations (<1 min)	+10% to -15%	

Table 200: Limit values for voltage changes and fluctuations

IEC 61000-2-1		
	EN 61800-3	Performance criteria
Voltage dips and short-term interruptions	10% to 100%	C

Table 201: Limit values for voltage dips and short-term interruptions

#### 4.2.3 Asymmetric voltages and frequency changes

IEC 61000-2-4, class 3		
	EN 61800-3	Performance criteria
Asymmetric voltages	3% negative component	A
Frequency change and change rate	±2%, 1%/s (±4 %, 2%/s if the power supply is isolated from general power mains)	

Table 202: Limit values for asymmetric voltages and frequency changes

<sup>31)</sup> Limit values from CISPR11, group 2, class A (second environment).

### 4.3 High-frequency disturbances in accordance with IEC 61800-3

These immunity tests are valid for industry (category C3). <sup>32)</sup>

#### 4.3.1 Electrostatic discharge

Tests in accordance with IEC 61000-4-2		
	EN 61800-3	Performance criteria
Contact discharge to powder-coated and bare metal housing parts	6 kV	B
Discharge through the air to plastic housing parts	8 kV	

Table 203: Limits for electrical discharge

#### 4.3.2 Electromagnetic fields

Tests in accordance with IEC 61000-4-3		
	EN 61800-3	Performance criteria
Housing, completely wired	80 MHz - 1 GHz, 10 V/m, 80% amplitude modulation 1 kHz	A

Table 204: Limits for electromagnetic fields

#### 4.3.3 Burst

Tests in accordance with IEC 61000-4-4		
	EN 61800-3	Performance criteria
Power connection	2 kV, 1 min, direct coupling	B
Connections for measurement and control functions in the process environment	2 kV, 1 min	
Signal interfaces, other wires	1 kV, 1 min	

Table 205: Limits for burst

#### 4.3.4 Surge

Tests in accordance with IEC 61000-4-5		
	EN 61800-3	Performance criteria
Power connection	1 kV (2 Ω) <sup>1)</sup> , DM, symmetrical 2 kV (12 Ω) <sup>1)</sup> , CM, unsymmetrical	B

Table 206: Limits for surge

1) The impedance from IEC 61000-4-5 has been added because it is not defined in IEC 61800-3.

#### 4.3.5 High-frequency conducted disturbances

Tests in accordance with IEC 61000-4-6		
	EN 61800-3	Performance criteria
Power connection	0.15 - 80 MHz, 10 V, 80% amplitude modulation 1 kHz	A
Connections for measurement and control functions in the process environment		
Signal interfaces, other wires		

Table 207: Limits for conducted disturbances (radio frequency)

<sup>32)</sup> Limit values from CISPR11, group 2, class A (second environment).

## 5 Requirements for emissions (EMC)

### 5.1 High-frequency emissions in accordance with IEC 61800-3

These emission tests are valid for industry (category C3). <sup>33)</sup>

#### 5.1.1 Disturbance voltages on the power connections

Tests in accordance with IEC 55011			
Continuous current on motor	Frequency range [MHz]	Quasi-peak value	Average
I ≤ 100 A	0.15 ≤ f < 0.5	100 dB (μV)	90 dB (μV)
	0.5 ≤ f < 5	86 dB (μV)	76 dB (μV)
	5 ≤ f < 30	90 dB (μV) Decreases with the logarithm of the frequency to 70	80 dB (μV) Decreases with the logarithm of the frequency to 60
100 A < I	0.15 ≤ f < 0.5	130 dB (μV)	120 dB (μV)
	0.5 ≤ f < 5	125 dB (μV)	115 dB (μV)
	5 ≤ f < 30	115 dB (μV)	105 dB (μV)

Table 208: Limits for disturbance voltages on the power connections

#### 5.1.2 Electromagnetic emissions

Tests in accordance with IEC 55011	
Frequency range [MHz]	Quasi-peak value
30 ≤ f ≤ 230	40 dB (μV/m), measured at distance of 30 m <sup>1)</sup>
230 < f ≤ 1000	50 dB (μV/m), measured at distance of 30 m <sup>1)</sup>

Table 209: Limit values for electro-magnetic emissions

1) Limit values are increased by 10 dB (μV/m) when measured from a distance of 10 m.

## 6 Other environmental limit values in accordance with IEC 61800-2

EN 61800-2	
Degree of pollution in accordance with IEC 61800-2, 4.1.2.1.	2 (non-conductive pollution)
Overvoltage category in accordance with IEC 60364-4-443:1999	II
EN 60529 protection	IP20
Reduction of the continuous current at installation altitudes over 500 m above sea level	10 % per 1000 m
Maximum installation altitude	2,000 m <sup>1)</sup>

Table 210: Other environmental limit values

1) Requirements that go above and beyond this need to be arranged with B&R.

<sup>33)</sup> Limit values from CISPR11, group 2, class A (second environment).

## 7 International certifications

B&R products and services comply with applicable standards. This includes international standards from organizations such as ISO, IEC and CENELEC, as well as national standards from organizations such as UL, CSA, FCC, VDE, ÖVE, etc. We are committed to ensuring the reliability of our products in an industrial environment.





Certifications	
USA and Canada 	All important B&R products are tested and listed by Underwriters Laboratories and checked quarterly by a UL inspector. This mark is valid for the USA and Canada and simplifies the certification of your machines and systems in these areas.
Europe 	This mark certifies that all harmonized EN standards for the applicable directives have been met.
Russian Federation 	GOST-R certification is available for the export of all ACOPOS servo drives to the Russian Federation.
	All important B&R servo drives have the FS - Functional Safety certification mark from TÜV Rheinland.

Table 211: International certifications

## 8 Standards and definitions for safety technology

### Stop functions in accordance with IEC 60204-1:2006 (electrical equipment for machines, Part 1: General Requirements)

There are three categories of stop functions:

Category	Description
0	Stop by immediately switching off the power to the machine drive elements (i.e. uncontrolled stop)
1	A controlled stop where the power to the machine drive elements remains on until the stop procedure is completed. The power is switched off after the stop is complete.
2	A controlled stop, the power to the machine drive elements is not switched off.

Table 212: Overview of stop function categories

The necessary stop functions must be determined based on a risk assessment of the machine. Stop functions in Category 0 and Category 1 must be able to function regardless of the operating mode. A Category 0 stop must have priority. Stop functions must have priority over assigned start functions. Resetting the stop function must never result in a dangerous state.

### Emergency stops in accordance with IEC 60204-1:2006 (Electrical Equipment for Machines, Part 1: General Requirements)

The following requirements are valid for an emergency stop in addition to the requirements for stop functions:

- It must have priority over all other functions and operations in all operating modes.
- The power to the machine drive elements which can cause a dangerous state must be switched off as quickly as possible without creating other dangers.
- Resetting is not permitted to cause a restart.

Emergency stops must be Category 0 or Category 1 stop functions. The stop function required must be determined based on a risk assessment for the machine.

For Category 0 emergency stop functions, only hard-wired electromechanical equipment can be used. Additionally, this functionality is not permitted to depend on electronic switching logic (hardware or software) or the transfer of commands via a communication network or data connection. <sup>34)</sup>

When using a Category 1 emergency stop function, it must be guaranteed that the power to the machine drive elements is completely switched off. These elements must be switched off using electromechanical equipment. <sup>35)</sup>

### Performance Levels (PL) in accordance with EN ISO 13849-1 (Safety of Machinery – Safety-related Parts of Control Systems, Part 1: General Design Principles)

The safety-related parts of control systems must meet one or more of the requirements for five defined Performance Levels. These Performance Levels define the required behavior of safety-related controller parts with regard to their resistance to errors.

Performance Level (in accordance with EN ISO 13849-1)	Safety integrity level - SIL (in accordance with IEC 61508-2)	Short description	System behavior
a	---	Safety-related components must be designed and built so that they can meet the expected operational requirements (no specific safety measures are implemented).	<b>Caution!</b> An error can cause the loss of safety functionality.
b	1	Safety-related components must be designed and built in such a way that only reliable components and safety principles are used. (e.g. prevention of short circuits through sufficient spacing, reducing the probability of errors by using oversized components, defining the failure route - bias current fail-safe, etc.).	<b>Caution!</b> An error can cause the loss of safety functionality.

Table 213: Overview of Performance Levels (PL)

<sup>34)</sup> In accordance with the national foreword of the valid German-language version of IEC 60204-1:2006, electronic equipment (and especially emergency stop systems) may be used regardless of the stop category, if e.g. it provides the same safety using the standards EN ISO 13849-1:2008 and/or IEC 61508 as required by EN 60204-1.

<sup>35)</sup> In accordance with the national foreword of the valid German-language version of IEC 60204-1:2006, electronic equipment (and especially emergency stop systems) may be used regardless of the stop category, if e.g. it provides the same safety using the standards EN ISO 13849-1:2008 and/or IEC 61508 as required by EN 60204-1.

Performance Level (in accordance with EN ISO 13849-1)	Safety integrity level - SIL (in accordance with IEC 61508-2)	Short description	System behavior
c	1	Safety-related components must be designed in such a way that their safety functionality is checked at suitable intervals by the machine controller. (e.g. automatic or manual check during startup).	<b>Caution!</b> An error between checks can cause the loss of safety functionality. The loss of safety functionality will be detected during the check.
d	2	Safety-related components must be designed in such a way that individual errors do not cause the loss of safety functionality. Individual errors should – if possible – be recognized the next time (or before) the safety function is required.	<b>Caution!</b> Safety functionality remains active when an error occurs. Some but not all errors are recognized. A buildup of errors can cause the safety functionality to fail.
e	3	Safety-related components must be designed in such a way that individual errors do not cause the loss of safety functionality. Individual errors must be recognized the next time (or before) the safety function is required. If this type of recognition is not possible, a buildup of errors is not permitted to cause the safety functionality to fail.	<b>Information:</b> Safety functionality remains active when an error occurs. Errors are recognized in time to prevent safety functionality from failing.

Table 213: Overview of Performance Levels (PL)

A suitable Performance Level must be selected separately for each drive system (or for each axis) based on a risk assessment. This risk assessment is a part of the total risk assessment for the machine.

The following risk graph (in accordance with EN ISO 13849-1, Appendix A) provides a simplified procedure for risk assessment:

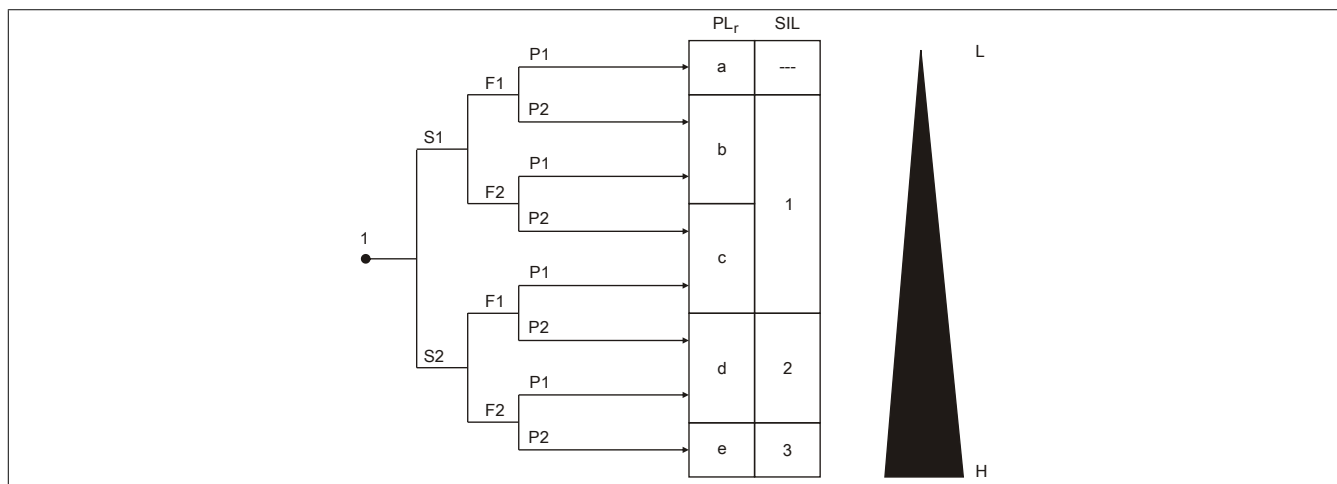


Figure 98: Risk diagram for determining the PL<sub>r</sub> for each safety function in accordance with EN ISO 13849-1, Appendix A

**Legend**

- 1 Starting point for assessing the impact on risk reduction
- L Low impact on risk reduction
- H High impact on risk reduction
- PL<sub>r</sub> Necessary performance level
- SIL Safety Integrity Level in accordance with IEC 61508-2

**Risk parameters**

- S Severity of injury
- S1 Slight (usually reversible) injury
- S2 Serious (usually irreversible) injury or death
- E Frequency and/or duration of the exposure to the hazard
- F1 Rare to often and/or short exposure to the hazard
- F2 Frequent to continuous and/or long exposure
- P Possibility to circumvent the danger or limit the damage
- P1 Possible under some conditions
- P2 Nearly impossible

The Performance Level to be used is determined by starting at the specified starting point and taking the risk parameters S, F and P into consideration.

**Restart inhibit in accordance with EN 1037/04.96 (Safety of Machinery – Prevention of Unexpected Startup)**

Keeping a machine in a state of rest when people are working in the danger zone is one of the most important requirements for safely operating machines.

Starting refers to the transition of a machine or its parts from a state of rest to a moving state. Any start is unexpected if it is caused by:

- A startup command sent because of a controller failure or because of external influences on the controller
- A startup command sent because of incorrect operation of a start element or another part of the machine
- Restoration of power supply after an interruption
- External/internal influences on parts of the machine

To prevent unexpected startup of machines or parts of machines, power should be removed and dissipated. If this is not practical (e.g. frequent, short interventions in danger zone), other measures must be taken:

- Measures to prevent random startup commands
- Measures to prevent random startup commands from causing unexpected startup
- Measures to automatically stop dangerous parts of the machine before a dangerous situation can be caused by unexpected startup



Figure 1:	EMC testing of ACOPOS servo drives - maximum security for the user.....	13
Figure 2:	Plug-in modules allow optimized, application-specific configuration of ACOPOS servo drives	14
Figure 3:	Configuring ACOPOS servo drives using B&R Automation Studio guarantees fast and easy implementation of application requirements.....	15
Figure 4:	Optimal control of the movement using NC Test and Trace functionality.....	17
Figure 5:	Cam editor - for creating movement profiles simply and precisely.....	18
Figure 6:	Compact, modular motion control applications.....	20
Figure 7:	Extensive, modular motion control applications with up to 253 axes.....	21
Figure 8:	ACOPOS in a CAN bus network.....	21
Figure 9:	Drive-based automation with ACOPOS.....	22
Figure 10:	Warning on the servo drive.....	25
Figure 11:	Warning on the servo drive.....	26
Figure 12:	ACOPOS servo drives - Status indicators.....	33
Figure 13:	ACOPOS 1010, 1016 - Pinout overview.....	48
Figure 14:	Trigger.....	54
Figure 15:	Limit.....	54
Figure 16:	Enable.....	54
Figure 17:	ACOPOS - Input/Output circuit diagram.....	55
Figure 18:	ACOPOS 1022, 1045, 1090 - Pinout overview.....	65
Figure 19:	Trigger.....	70
Figure 20:	Limit.....	70
Figure 21:	Enable.....	70
Figure 22:	ACOPOS 1022, 1045, 1090 - Input/Output circuit diagram.....	71
Figure 23:	ACOPOS 1180, 1320 - Pinout overview.....	80
Figure 24:	Trigger.....	85
Figure 25:	Limit.....	85
Figure 26:	Enable.....	85
Figure 27:	ACOPOS 1180, 1320 - Input/Output circuit diagram.....	86
Figure 28:	ACOPOS 1640, 128M - Pinout overview.....	95
Figure 29:	Trigger.....	99
Figure 30:	Limit.....	100
Figure 31:	Enable.....	100
Figure 32:	ACOPOS 1640, 128M - Input/Output circuit diagram.....	101
Figure 33:	AC110 - Input/Output circuit diagram.....	104
Figure 34:	AC114 - Input/Output circuit diagram.....	107
Figure 35:	AC120 - Input/Output circuit diagram.....	111
Figure 36:	AC121 - Input/Output circuit diagram.....	114
Figure 37:	AC122 - Input/Output circuit diagram.....	117
Figure 38:	AC123 - Input/Output circuit diagram.....	121
Figure 39:	AC130 - Input/Output circuit diagram.....	130
Figure 40:	AC131 - Input/Output circuit diagram.....	134
Figure 41:	Remove the cover for the lithium battery.....	142
Figure 42:	Hold the battery correctly.....	142
Figure 43:	Removal strip should be pulled to the right.....	142
Figure 44:	Remove the cover for the lithium battery.....	153
Figure 45:	Hold the battery correctly.....	153
Figure 46:	Removal strip should be pulled to the right.....	153
Figure 47:	8B0W - Pinout overview.....	158
Figure 48:	8CMxxx.12-0 motor cables - Cable diagram.....	170
Figure 49:	8CMxxx.12-1, 8CMxxx.12-3 motor cables - Cable diagram.....	170
Figure 50:	8CMxxx.12-5 motor cables - Cable diagram.....	171
Figure 51:	EnDat encoder cables - Cable diagram.....	174
Figure 52:	Cable diagram for resolver cables.....	177
Figure 53:	Attaching the eye bolt included in delivery to ACOPOS 1640, 128M drives.....	183
Figure 54:	ACOPOS 1010, 1016 - Dimension diagram and installation dimensions.....	184
Figure 55:	ACOPOS 1022, 1045, 1090 - Dimension diagram and installation dimensions.....	185
Figure 56:	ACOPOS 1180, 1320 - Dimension diagram and installation dimensions.....	186

Figure 57:	ACOPOS 1640 - Dimension diagram and installation dimensions.....	187
Figure 58:	ACOPOS 128M - Dimension diagram and installation dimensions.....	188
Figure 59:	Dimension diagram for 8B0W0045H000.001-1, 8B0W0079H000.001-1.....	189
Figure 60:	8B0W external braking resistors - Installation dimensions.....	190
Figure 61:	Installing ACOPOS plug-in modules.....	191
Figure 62:	Installing various ACOPOS series devices directly next to each other.....	193
Figure 63:	Function diagram of filter fans.....	194
Figure 64:	Function diagram of air/air heat exchangers .....	195
Figure 65:	Function diagram of air/water heat exchangers .....	196
Figure 66:	Placing a cooling unit on top of the control cabinet.....	197
Figure 67:	Placing a cooling unit on the front of the control cabinet.....	198
Figure 68:	Stripped cable end.....	199
Figure 69:	Cable end with shielding mesh pulled back.....	199
Figure 70:	Pulling out the separately shielded signal lines.....	200
Figure 71:	Cable end without stranding elements.....	200
Figure 72:	Cable ends with shortened shielding mesh.....	201
Figure 73:	Attaching the shielding mesh.....	201
Figure 74:	Wire ends with wire end sleeves.....	201
Figure 75:	ACOPOS X3, individual power mains connection - Circuit diagram.....	206
Figure 76:	ACOPOS X3, power mains connection for a drive group - Circuit diagram.....	209
Figure 77:	ACOPOS X3, power mains connection for a drive group with optional line choke - Circuit diagram.....	209
Figure 78:	ACOPOS X2 DC bus connections - Circuit diagram.....	212
Figure 79:	DC bus power supply for ACOPOS servo drives.....	214
Figure 80:	ACOPOS X4/X5 motor connections - Circuit diagram.....	215
Figure 81:	ACOPOS X6, external braking resistor on ACOPOS 1180/1320/1640/128M - Circuit diagram.....	217
Figure 82:	Movement and load profile for one axis in a sample application.....	219
Figure 83:	Peak load capacity - 8V1180 / 8V1320.....	223
Figure 84:	Peak load capacity - 8V1640 / 8V128M.....	223
Figure 85:	Determining the peak load factor k.....	226
Figure 86:	Thermal equivalent circuit diagram for the external braking resistor.....	227
Figure 87:	Basic selection of the cooling system.....	230
Figure 88:	Connection diagram for ground and shield connections.....	240
Figure 89:	Cable shielding in DSUB housing.....	241
Figure 90:	Grounding the POWERLINK cable shielding.....	241
Figure 91:	Connecting cables to plug-in modules.....	244
Figure 92:	Block diagram of safe pulse disabling.....	248
Figure 93:	STO, Category 3 / SIL 2 / PL d (Variant A).....	250
Figure 94:	STO, Category 3 / SIL 2 / PL d (Variant B).....	251
Figure 95:	STO, SLS, SOS - Safety Category 3 / SIL 2 / PL d.....	252
Figure 96:	SS1, SLS, SS2 - Safety Category 3 / SIL 2 / PL d (Variant A).....	254
Figure 97:	SS1, SLS, SS2 - Safety Category 3 / SIL 2 / PL d (Variant B).....	256
Figure 98:	Risk diagram for determining the PL <sub>r</sub> for each safety function in accordance with EN ISO 13849-1, Appendix A.....	266

Table 1:	Manual history.....	11
Table 2:	Description of the safety notices used in this documentation.....	23
Table 3:	Environmentally friendly separation of materials.....	27
Table 4:	Overview of the ACOPOS servo drive series.....	32
Table 5:	LED status - ACOPOS servo drives.....	33
Table 6:	Status changes when booting the operating system loader.....	34
Table 7:	Error status with reference to the CAN plug-in module AC110.....	34
Table 8:	Error status with reference to the POWERLINK V2 plug-in module AC114.....	34
Table 9:	8V1010.00-2, 8V1010.001-2 - Order data.....	35
Table 10:	8V1010.00-2, 8V1010.001-2 - Technical data.....	36
Table 11:	8V1010.50-2, 8V1010.501-2 - Order data.....	38
Table 12:	8V1010.50-2, 8V1010.501-2 - Technical data.....	39
Table 13:	8V1016.00-2, 8V1016.001-2 - Order data.....	41
Table 14:	8V1016.00-2, 8V1016.001-2 - Technical data.....	42
Table 15:	8V1016.50-2, 8V1016.501-2 - Order data.....	45
Table 16:	8V1016.50-2, 8V1016.501-2 - Technical data.....	46
Table 17:	X1 connector - Pinout.....	49
Table 18:	X2 connector - Pinout.....	49
Table 19:	X2 connector - Pinout.....	49
Table 20:	X3 connector - Pinout.....	50
Table 21:	X3 connector - Pinout.....	50
Table 22:	X4a connector - Pinout.....	51
Table 23:	X4b connector - Pinout.....	51
Table 24:	Activation for the external holding brake.....	52
Table 25:	X5 connector - Pinout.....	53
Table 26:	Protective ground connection (PE) - ACOPOS.....	53
Table 27:	8V1022.00-2, 8V1022.001-2 - Order data.....	56
Table 28:	8V1022.00-2, 8V1022.001-2 - Technical data.....	57
Table 29:	8V1045.00-2, 8V1045.001-2 - Order data.....	59
Table 30:	8V1045.00-2, 8V1045.001-2 - Technical data.....	60
Table 31:	8V1090.00-2, 8V1090.001-2 - Order data.....	62
Table 32:	8V1090.00-2, 8V1090.001-2 - Technical data.....	63
Table 33:	X1 connector - Pinout.....	66
Table 34:	X2 connector - Pinout.....	66
Table 35:	X3 connector - Pinout.....	66
Table 36:	X4a connector - Pinout.....	67
Table 37:	X4b connector - Pinout.....	67
Table 38:	Activation for the external holding brake.....	68
Table 39:	X5 connector - Pinout.....	69
Table 40:	Protective ground connection (PE) - ACOPOS.....	69
Table 41:	8V1180.00-2, 8V1180.001-2 - Order data.....	72
Table 42:	8V1180.00-2, 8V1180.001-2 - Technical data.....	73
Table 43:	8V1320.00-2, 8V1320.001-2 - Order data.....	76
Table 44:	8V1320.00-2, 8V1320.001-2 - Technical data.....	77
Table 45:	X1 connector - Pinout.....	81
Table 46:	X2 connector - Pinout.....	81
Table 47:	X3 connector - Pinout.....	81
Table 48:	X4a connector - Pinout.....	82
Table 49:	X4b connector - Pinout.....	82
Table 50:	Activation for the external holding brake.....	83
Table 51:	X5 connector - Pinout.....	84
Table 52:	X6 connector - Pinout.....	84
Table 53:	Protective ground connection (PE) - ACOPOS.....	84
Table 54:	8V1640.00-2, 8V1640.001-2 - Order data.....	87
Table 55:	8V1640.00-2, 8V1640.001-2 - Technical data.....	88
Table 56:	8V128M.00-2, 8V128M.001-2 - Order data.....	91
Table 57:	8V128M.00-2, 8V128M.001-2 - Technical data.....	92

Table 58:	X1 connector - Pinout.....	96
Table 59:	X2 connector - Pinout.....	96
Table 60:	X3 connector - Pinout.....	96
Table 61:	X4a connector - Pinout.....	97
Table 62:	X4b connector - Pinout.....	97
Table 63:	Activation for the external holding brake.....	98
Table 64:	X5 connector - Pinout.....	99
Table 65:	X6 connector - Pinout.....	99
Table 66:	The maximum number of plug-in modules depends on the size of the servo drive.....	102
Table 67:	8AC110.60-2 - Order data.....	102
Table 68:	8AC110.60-2 - Technical data.....	102
Table 69:	Setting the CAN station number.....	103
Table 70:	AC110 CAN interface - Pinout.....	103
Table 71:	8AC114.60-2 - Order data.....	105
Table 72:	8AC114.60-2 - Technical data.....	105
Table 73:	Setting the POWERLINK station number.....	106
Table 74:	AC114 - Status LEDs.....	106
Table 75:	POWERLINK - LED status indicators.....	106
Table 76:	AC114 POWERLINK V2 interface - Pinout.....	107
Table 77:	8AC120.60-1 - Order data.....	108
Table 78:	8AC120.60-1 - Technical data.....	109
Table 79:	AC120 EnDat encoder interface - Pinout.....	110
Table 80:	8AC121.60-1 - Order data.....	112
Table 81:	8AC121.60-1 - Technical data.....	112
Table 82:	AC121 HIPERFACE encoder interface - Pinout.....	113
Table 83:	8AC122.60-3 - Order data.....	115
Table 84:	8AC122.60-3 - Technical data.....	115
Table 85:	AC122 resolver interface - Pinout.....	117
Table 86:	8AC123.60-1 - Order data.....	118
Table 87:	8AC123.60-1 - Technical data.....	118
Table 88:	AC123 incremental encoder and SSI absolute encoder interface - Pinout.....	120
Table 89:	8AC125.60-1 - Order data.....	122
Table 90:	8AC125.60-1 - Technical data.....	122
Table 91:	AC125 BiSS encoder interface - Pinout.....	123
Table 92:	8AC126.60-1 - Order data.....	124
Table 93:	8AC126.60-1 - Technical data.....	124
Table 94:	BAT Status LED - AC126.....	125
Table 95:	AC126 EnDat 2.2 interface - Pinout.....	126
Table 96:	8AC130.60-1 - Order data.....	127
Table 97:	8AC130.60-1 - Technical data.....	127
Table 98:	AC130 digital mixed module - Pinout.....	129
Table 99:	8AC131.60-1 - Order data.....	131
Table 100:	8AC131.60-1 - Technical data.....	131
Table 101:	AC131 mixed module - Pinout.....	133
Table 102:	8AC140.60-3 - Order data.....	135
Table 103:	8AC140.61-3 - Order data.....	136
Table 104:	8AC140.60-3, 8AC140.61-3 - Technical data.....	136
Table 105:	8AC140.60-3, 8AC140.61-3 - Status indicators.....	139
Table 106:	Setting the CAN station number.....	139
Table 107:	Setting the PROFIBUS station number.....	139
Table 108:	Reset button.....	140
Table 109:	Application memory.....	140
Table 110:	Backup battery.....	140
Table 111:	X1 connector (RS232) - Pinout.....	144
Table 112:	X2 connector (CAN) - Pinout.....	144
Table 113:	X3 connector (PROFIBUS) - Pinout.....	144
Table 114:	X4 connector (inputs/outputs) - Pinout.....	144

Table 115:	X6 connector (Ethernet) - Pinout.....	145
Table 116:	8AC141.60-2, 8AC141.61-3 - Order data.....	146
Table 117:	8AC141.60-2, 8AC141.61-3 - Technical data.....	147
Table 118:	AC141 - Status indicators.....	150
Table 119:	Setting the CAN station number.....	150
Table 120:	Setting the CAN station number (IF3).....	150
Table 121:	Reset button.....	151
Table 122:	Application memory.....	151
Table 123:	Backup battery.....	151
Table 124:	X1 connector (RS232) - Pinout.....	155
Table 125:	X2 connector (CAN1) - Pinout.....	155
Table 126:	X3 connector (CAN2) - Pinout.....	155
Table 127:	X4 connector (inputs/outputs) - Pinout.....	155
Table 128:	X5 connector (X2X) - Pinout.....	156
Table 129:	X6 connector (Ethernet) - Pinout.....	156
Table 130:	8B0W0045H000.000-1, 8B0W0045H000.001-1, 8B0W0079H000.000-1, 8B0W0079H000.001-1 - Order data.....	157
Table 131:	8B0W0045H000.000-1, 8B0W0045H000.001-1, 8B0W0079H000.000-1, 8B0W0079H000.001-1 - Technical data.....	157
Table 132:	8CM005.12-0, 8CM007.12-0, 8CM010.12-0, 8CM015.12-0, 8CM020.12-0, 8CM025.12-0 - Order data.....	160
Table 133:	8CM005.12-0, 8CM007.12-0, 8CM010.12-0, 8CM015.12-0, 8CM020.12-0, 8CM025.12-0 - Technical data.....	160
Table 134:	8CM005.12-1, 8CM007.12-1, 8CM010.12-1, 8CM015.12-1, 8CM020.12-1, 8CM025.12-1 - Order data.....	162
Table 135:	8CM005.12-1, 8CM007.12-1, 8CM010.12-1, 8CM015.12-1, 8CM020.12-1, 8CM025.12-1 - Technical data.....	162
Table 136:	8CM005.12-3, 8CM007.12-3, 8CM010.12-3, 8CM015.12-3, 8CM020.12-3, 8CM025.12-3 - Order data.....	164
Table 137:	8CM005.12-3, 8CM007.12-3, 8CM010.12-3, 8CM015.12-3, 8CM020.12-3, 8CM025.12-3 - Technical data.....	164
Table 138:	8CM005.12-5, 8CM007.12-5, 8CM010.12-5, 8CM015.12-5, 8CM020.12-5, 8CM025.12-5 - Order data.....	166
Table 139:	8CM005.12-5, 8CM007.12-5, 8CM010.12-5, 8CM015.12-5, 8CM020.12-5, 8CM025.12-5 - Technical data.....	166
Table 140:	8CM005.12-8, 8CM007.12-8, 8CM010.12-8, 8CM015.12-8, 8CM020.12-8, 8CM025.12-8 - Order data.....	168
Table 141:	8CM005.12-8, 8CM007.12-8, 8CM010.12-8, 8CM015.12-8, 8CM020.12-8, 8CM025.12-8 - Technical data.....	168
Table 142:	Motor cable construction.....	169
Table 143:	8CMxxx.12-0, 8CMxxx.12-1, 8CMxxx.12-3 motor cables - Pinout.....	169
Table 144:	8CMxxx.12-5 motor cables - Pinout.....	170
Table 145:	8CE005.12-1, 8CE007.12-1, 8CE010.12-1, 8CE015.12-1, 8CE020.12-1, 8CE025.12-1 - Order data.....	172
Table 146:	8CE005.12-1, 8CE007.12-1, 8CE010.12-1, 8CE015.12-1, 8CE020.12-1, 8CE025.12-1 - Technical data.....	172
Table 147:	EnDat encoder cable construction.....	173
Table 148:	EnDat encoder cables - Pinout.....	173
Table 149:	8CR005.12-1, 8CR007.12-1, 8CR010.12-1, 8CR015.12-1, 8CR020.12-1, 8CR025.12-1 - Order data.....	175
Table 150:	8CR005.12-1, 8CR007.12-1, 8CR010.12-1, 8CR015.12-1, 8CR020.12-1, 8CR025.12-1 - Technical data.....	175
Table 151:	Resolver cable construction.....	176
Table 152:	Resolver cables - Pinout.....	176
Table 153:	8PM001.00-1, 8PM002.00-1, 8PM003.00-1 - Order data.....	178
Table 154:	8PM001.00-1, 8PM002.00-1, 8PM003.00-1 - Technical data.....	178
Table 155:	8PE001.00-1 - Order data.....	180
Table 156:	8PE001.00-1 - Technical data.....	180
Table 157:	8PR001.00-1 - Order data.....	181

Table 158:	8PR001.00-1 - Technical data.....	181
Table 159:	Slot overview for ACOPOS plug-in modules.....	191
Table 160:	Overview of the vertical offsets (ACOPOS - ACOPOS).....	193
Table 161:	Supply voltage range for ACOPOS servo drives.....	204
Table 162:	Selection of the protective ground wire cross section.....	204
Table 163:	Protective ground conditions depending on the ACOPOS device.....	205
Table 164:	Constant k .....	207
Table 165:	Maximum current load for PVC insulated three-phase cables or individual wires .....	207
Table 166:	Tripping characteristics of the fuse for the power mains connection.....	208
Table 167:	Model numbers for the line chokes available from B&R.....	210
Table 168:	Discharge capacitance $C_A$ .....	211
Table 169:	Maximum current load for specially insulated three-phase cables .....	215
Table 170:	Braking resistors for ACOPOS servo drives.....	216
Table 171:	The location where the fuse for the external braking resistor connection is installed.....	218
Table 172:	Overview of braking resistor data - 8B0W .....	220
Table 173:	Series and parallel connection of braking resistors.....	221
Table 174:	ParIDs for setting external braking resistor parameters.....	227
Table 175:	Maximum power output for all slots depending on the ACOPOS servo drive.....	228
Table 176:	Power consumption $P_{\text{module}}$ of ACOPOS plug-in modules.....	228
Table 177:	Maximum current requirements and constant k .....	229
Table 178:	Calculation of the effective control cabinet surface A (DIN VDE 57 660 part 500 or IEC 890).....	231
Table 179:	Determining the heat dissipation of all devices in the control cabinet.....	231
Table 180:	Compensation factor f depending on the control cabinet's installation altitude.....	232
Table 181:	Determining the heat dissipation of all devices in the control cabinet.....	233
Table 182:	Determining the heat dissipation of all devices in the control cabinet.....	234
Table 183:	Determining the heat dissipation of all devices in the control cabinet.....	235
Table 184:	Formula variables used.....	237
Table 185:	Grounding of the motor cable on the ACOPOS servo drive.....	242
Table 186:	Terminal cross sections for ACOPOS servo drives.....	245
Table 187:	Safety classifications, criteria and characteristics for safe pulse disabling.....	247
Table 188:	Overview of safety functions according to standards.....	247
Table 189:	Applicable standards for ACOPOS servo drives.....	259
Table 190:	Mechanical conditions during operation .....	260
Table 191:	Mechanical conditions during transport .....	260
Table 192:	Climate conditions during operation.....	260
Table 193:	Climate conditions (temperature) during storage .....	260
Table 194:	Climate conditions (humidity) during storage .....	260
Table 195:	Climate conditions during transport .....	260
Table 196:	Evaluation criteria (performance criteria) for immunity to disturbances.....	261
Table 197:	Limit values for power mains harmonics.....	261
Table 198:	Limit values for commutation notches / voltage distortions.....	261
Table 199:	Limit values for voltage changes and fluctuations.....	261
Table 200:	Limit values for voltage dips and short-term interruptions.....	261
Table 201:	Limit values for asymmetric voltages and frequency changes.....	261
Table 202:	Limits for electrical discharge.....	262
Table 203:	Limits for electromagnetic fields.....	262
Table 204:	Limits for burst.....	262
Table 205:	Limits for surge.....	262
Table 206:	Limits for conducted disturbances (radio frequency).....	262
Table 207:	Limits for disturbance voltages on the power connections.....	263
Table 208:	Limit values for electro-magnetic emissions.....	263
Table 209:	Other environmental limit values.....	263
Table 210:	International certifications.....	264
Table 211:	Overview of stop function categories.....	265
Table 212:	Overview of Performance Levels (PL).....	265

**A**

AC122 resolver interface.....	115
AC140 CPU module.....	146
Accident prevention regulations.....	23
ACOPOS configurations	
CAN bus.....	21
Compact, modular.....	20
Drive-based control.....	22
Extensive, modular.....	21
ACOPOS servo drive in DC bus network.....	225
ACOPOS servo drive series.....	32
active braking of the motor.....	214
Air/air heat exchangers.....	195
Function diagram.....	195, 195
Air/water heat exchangers.....	196
Function diagram.....	196, 196
Apparent power Transformer.....	204
Applicable standards.....	259
Arrangement of cooling units.....	197
Attaching the eye bolt.....	183
Autotransformer.....	204

**B**

B&R Automation Studio.....	15, 17
Backup batteries.....	126
Backup battery	
AC140.....	140
AC141.....	151
Balancing resistors.....	213
Battery change interval.....	141, 152
Battery disposal.....	142, 153
BatteryInfo.....	141, 152
Battery module.....	126
Battery monitoring.....	141, 152
BiSS encoder interface AC125.....	122
Braking resistor data.....	220, 220
Braking resistors.....	216

**C**

Cable	
Assembly.....	199
Cable connection	
via DSUB plug.....	241
via RJ45 plug.....	241
via terminals.....	241
Cable diagram	
8CM motor cables.....	170, 171
8CR resolved cables - Cable diagram.....	177
EnDat cable - 8CE.....	174
Cables	
EnDat cables.....	172
General information.....	160
Motor cables.....	160
Resolver cables.....	175
Cables from other manufacturers.....	160
Cable shields.....	239
Calculating specifications.....	26
Calculating the effective control cabinet surface area A.....	231
Calculation for dimensioning the braking resistor	

Average brake power for one cycle.....	220
Average temperature in continuous operation.....	221
Braking energy for one cycle.....	220
Braking energy per braking procedure.....	220
Continuous power.....	224
Determining braking resistor data.....	220
Maximum brake power within one cycle.....	220
Maximum heat that can be absorbed by the braking resistor.....	221
Maximum temperature in continuous operation.....	221
Power calculation.....	220
Thermal resistance.....	224
Thermal time constant of the braking resistor.....	221
Total braking time within one cycle.....	220
Cam profile editor.....	18
CAN Interface AC110.....	102
Causes of errors.....	26
Certifications.....	264
Choosing a fuse	
Suitable fuse.....	206
Clampable cross sections.....	245
Climate conditions	
During operation.....	260
During transport.....	260, 260
Humidity during storage.....	260, 260
Temperature during storage.....	260, 260
CompactFlash card.....	135, 146
Condensation.....	197
Conditions	
Connection and environmental conditions.....	23
External braking resistor.....	224
Connecting encoders, sensors and actuators.....	14
Connecting external braking resistors.....	217
Connecting the mounting bracket to ground.....	241
Connection cable for external braking resistor.....	242
Connection diagram for ground and shield connections.....	240
Connectors	
EnDat connectors.....	180
General information.....	178
Motor connectors.....	178
Resolver connectors.....	181
Constant k for servo drives.....	207, 229, 207, 229
Cooling systems.....	194, 230
Cooling systems in control cabinets.....	194
Cooling unit temperature.....	197
CPU module - AC140.....	135
Criteria for safe pulse disabling.....	247
Cross sections, clampable.....	245
Current load.....	206

## D

DC bus.....	212, 212
DC bus connections.....	213
DC bus power supplies.....	32
DC-DC converter.....	248
DC-to-DC converter.....	249
Design	
Motor connection.....	215
Determining power mains cross section.....	207
Determining the peak load factor k.....	226
Determining the value of the braking resistor.....	224
Digital mixed module - AC130.....	127

Dimension diagrams	
ACOPOS 1010, 1016.....	184
ACOPOS 1022, 1045, 1090.....	185
ACOPOS 1180, 1320.....	186
ACOPOS 128M.....	188
ACOPOS 1640.....	187
Dimension diagrams and installation dimensions	
External braking resistors.....	189
Dimensioning	
Air/air heat exchangers.....	234
Air/water heat exchanger.....	235
Braking resistors.....	216
DC bus.....	212
Filter fans.....	232
Fuse.....	206
Line contactor.....	208
Motor connection.....	215
Natural convection.....	231
Power mains.....	206
Power mains connection.....	203
Dimensioning the motor cable cross section.....	215
Directives.....	259
Discharge capacitance.....	211
Disposal.....	27
Drive-based automation.....	22

## E

Effective value for the motor current.....	215
Electromagnetic compatibility of the installation.....	239
Electronic gears.....	118
Embedded parameter chip.....	13
Emergency stops.....	265
Encoder cable.....	242
Encoder connectors	
EnDat.....	180
Resolver.....	181
Encoders for external axes.....	115
Encoder systems	
BiSS encoder interface.....	122
EnDat encoder interface.....	108
HIPERFACE encoder interface.....	112
Incremental / SSI encoder interface.....	118
Resolver interface.....	115
EnDat.....	108
EnDat 2.2 interface - AC126.....	124
EnDat cable	
Order data.....	172
Wiring.....	173
EnDat cables	
Technical data.....	172
EnDat connectors	
Order data.....	180
Technical data.....	180
EnDat encoder interface AC120.....	108
Environmental limit values.....	263, 263
Environmentally friendly disposal.....	27
Environmentally friendly separation of materials.....	27, 27
ESD.....	23
ESD protective measures.....	24
E-stop button.....	26
European directives.....	259

Evaluation criteria for immunity to disturbances.....	261
Exchanging the battery on CPU modules	
AC140.....	142
AC141.....	153
External braking resistor	
Location of the fuse.....	218
External braking resistor connection fuse.....	218

## F

Fault current protection.....	211
Fault current protective device.....	211
Filter fans	
Dimensioning.....	232
Function diagram.....	194
Formula variables.....	237
Forward movement.....	249
Functional safety.....	26
Function blocks.....	15, 16
Function diagram	
Filter fans.....	194, 194
Fuse.....	206
Fuse for the power mains connection.....	206, 210

## G

Grounding clamps.....	242
Grounding of the motor cable on the ACOPOS servo drive.....	242
Grounding plate.....	242
Grounding the cable shield.....	241
Guidelines for ESD handling.....	24

## H

Hazards.....	23
High voltage testing.....	243
HIPERFACE.....	112

## I

IGBT driver.....	248
Improper seal on the control cabinet.....	194
Increased discharge current.....	204
Incremental / SSI absolute encoder interface AC123.....	118
Inductive switching elements.....	239
Input/Output circuit diagram	
AC120.....	111
AC121.....	114
AC122.....	117
AC123.....	121
AC130.....	130
AC131.....	134
ACOPOS 1010, 1016.....	54
ACOPOS 1022, 1045, 1090.....	70
ACOPOS 1180, 1320.....	85
ACOPOS 1640, 128M.....	99
Input/output diagram	
AC110.....	104
input/output diagram	
AC114.....	107
Installation.....	239
Air/air heat exchangers.....	195

Air/air heat exchangers behind mounting plates.....	195
Air/water heat exchangers.....	196
Air/water heat exchangers behind mounting plates.....	196
installation	
Plug-in module.....	191
Installation conditions.....	183
Installation dimensions	
ACOPOS 1010, 1016.....	184
ACOPOS 1022, 1045, 1090.....	185
ACOPOS 1180, 1320.....	186
ACOPOS 128M.....	188
ACOPOS 1640.....	187
External braking resistors.....	189
Installing plug-in module cables.....	244
Insulation resistance testing.....	243
Intermediate transformer.....	204, 204
Internal monitoring.....	26
Isolation transformers.....	203
IT power mains.....	203

## L

LED status	
AC110.....	34
AC114.....	34
ACOPOS servo drives.....	34
Operating system loader.....	34
Limit values	
Asymmetric voltages.....	261
Burst.....	262
Commutation notches.....	261
Disturbance voltages on the power connections.....	263
Electromagnetic emissions.....	263
Electromagnetic fields.....	262
Electrostatic discharge.....	262
Frequency changes.....	261
High-frequency conducted disturbances.....	262
Power mains harmonics.....	261
Short-term interruptions.....	261
Surge.....	262
Voltage changes.....	261
Voltage dips.....	261
Voltage distortions.....	261
Voltage fluctuations.....	261
Line shielding.....	239

## M

Machine guidelines.....	23
Main principle of air/air heat exchangers.....	234
Main principle of the air/water heat exchanger.....	235
Mains configurations.....	203
IT power mains.....	203
TN power mains.....	203
TN-S power mains.....	203
TT power mains.....	203
Manual history.....	11
Manufacturers of fault current protective devices.....	211
Maximum current load for PVC insulated three-phase cables.....	207, 207
Maximum current load for specially insulated three-phase cables.....	215, 215
Maximum current requirements 24 VDC.....	229, 229
Mechanical conditions	

During operation.....	260, 260
During transport.....	260, 260
Mission time.....	26
Mixed module - AC131.....	131
MODE C.....	122
Motor cable assembly.....	199
Motor cables.....	160, 199
Motor connection.....	215
Motor connectors.....	178
Motor line.....	242
Motors	
Embedded parameter chip.....	13
General.....	13
Mounting	
Second protective ground wire.....	205
Multiple errors in the IGBT bridge.....	249

## N

Natural convection.....	194
Networking drives, controllers and visualization units.....	14
Nominal continuous power of a braking resistor.....	225
Number of plug-in modules depending on the size of the servo drive.....	102

## O

Operation.....	25, 260
Operation with the control cabinet doors open.....	197
Optional accessories	
AC110.....	102
AC120.....	108
AC122.....	115
AC126.....	124
AC140.....	135
AC141.....	146
ACOPOS 1010.....	35
ACOPOS 1016.....	41
ACOPOS 1022.....	56
ACOPOS 1045.....	59
ACOPOS 1090.....	62
ACOPOS 1180.....	72
ACOPOS 128M.....	91
ACOPOS 1320.....	76
ACOPOS 1640.....	87
Oscilloscope function.....	18
Overview of braking resistor data.....	220, 220

## P

Packaging.....	24
Parallel connection	
Braking resistor.....	221
Parameter memory.....	108, 112
Partially-coated circuit boards.....	13
Performance criteria for immunity to disturbances.....	261
Performance Levels (PL).....	265
Permanently excited synchronous motors.....	249
Pinout	
AC140.....	144
AC141.....	155
ACOPOS 1010, 1016.....	48
ACOPOS 1022, 1045, 1090.....	65

ACOPOS 1180, 1320.....	80
ACOPOS 1640, 128M.....	95
Pinouts	
8B0W braking resistor.....	158
AC110.....	103
AC114.....	107
AC120.....	110
AC121.....	113
AC122.....	117
AC123.....	120
AC125.....	123
AC126.....	126
AC130.....	129
AC131.....	133
PLCopen.....	16
Plug-in module cables.....	244
Plug-in module combinations.....	228
Plug-in modules	
AC110.....	102
AC114.....	105
AC120.....	108
AC121.....	112
AC122.....	115
AC123.....	118
AC125.....	122
AC126.....	124
AC130.....	127
AC131.....	131
AC140.....	135
AC140 - Additional functions.....	135
AC140 backup battery.....	140
AC140 battery cover.....	140
AC140 indicators.....	139
AC140 - Reset button.....	140
AC141.....	146
AC141 - Additional functions.....	146
AC141 backup battery.....	151
AC141 battery cover.....	151
AC141 indicators.....	150
AC141 - Reset button.....	151
plug-in modules	
Installing and removing.....	191
Plug-in modules	
Using AC140 application memory.....	140
Using AC141 application memory.....	151
Plug-in module status indicators	
AC110.....	103
AC130.....	129
AC131.....	133
AC140.....	139
AC141.....	150
Plug-in module status indicators -	
AC114.....	106
Positioning tasks.....	15
Power calculation.....	220
Power consumption of the ACOPOS plug-in modules.....	228
Power failure.....	214
Power failures.....	32
POWERLINK.....	19
POWERLINK network cabling.....	241
POWERLINK V2 interface.....	105
Power mains connection	

ACOPOS - Individual.....	206
Drive groups.....	209
Power mains systems.....	203, 203
Power output for all slots.....	228
Program memory.....	135, 146
Programming.....	15
Programming languages.....	16
Proof test interval.....	26
Proper ESD handling.....	24
Protection type - Connectors.....	178
Protective ground (PE) discharge current.....	211
Protective ground conductor system.....	243
Protective ground wires (PE).....	241

## Q

Qualified personnel.....	23
--------------------------	----

## R

Rated current for the fuse.....	206
Rated current of the line contactor.....	208
RCD - residual current-operated protective device.....	211
Removing plug-in modules.....	192, 192
Required accessories	
AC126.....	124
AC130.....	127
AC131.....	131
AC140.....	135
AC141.....	146
Requirements for cooling systems	
for air/air heat exchangers.....	234
for filter fans.....	232
for natural convection.....	231
Resolver cable	
Construction.....	176
Order data.....	175
Technical data.....	175
Resolver connectors.....	181
Response speeds.....	19
Restart inhibit.....	267
Risk assessment.....	266
Risk graph.....	266
Risk parameters.....	266

## S

Safe pulse disabling.....	247
Safety.....	13
Safety characteristics for safe pulse disabling.....	247
Safety classifications.....	247, 247
Safety functions	
according to the standard.....	247, 247
Secure restart inhibit.....	253, 255, 257
SLS.....	253, 255, 257
SOS.....	253
SS1.....	255, 257
SS2.....	255, 257
STO.....	250, 251, 253
Safety functions that can be implemented.....	247
Safety guidelines.....	23
Safety integrity level - SIL.....	265

Safety measures.....	26
Safety-related parts of a control system.....	265
SCCR.....	203
Screws for fastening the module.....	241
Second protective ground wire.....	241
Selection	
Cooling system.....	230
Protective ground wire.....	204
Series connection - Braking resistor.....	221
Service work.....	13
Setting parameters.....	13
Setting parameters for external braking resistors.....	227
Setting station numbers	
CAN.....	103
Setting the CAN station number.....	103, 139, 150
Setting the POWERLINK station number.....	106
Setting the PROFIBUS station number - AC140.....	139
Setting the station number	
CAN.....	139, 150
POWERLINK.....	106
Shaft key.....	26
Shield clamps.....	239
Shield connection for the motor cable using grounding clamps.....	242
Shield connections.....	240
Shielded cables.....	239, 239
Short circuit between two conductors.....	250
Software.....	16
Specifications.....	26
Standards.....	259
Starting of machines.....	267
Status indicators - ACOPOS servo drives.....	33
Stop command (code example).....	258
Stop function categories.....	265
Stop functions.....	265
Storage.....	24, 260
Structure	
Individual power mains connection.....	206
Power mains connection for drive groups.....	209
Suppressor elements.....	239
Synchronous motors, permanently excited.....	249

## T

Terminating resistor.....	139, 150, 150
Thermal equivalent circuit diagram.....	227
Thermal equivalent effective value for the motor current.....	215
Three-phase induction motors.....	249
Three-phase transformers.....	203
TN power mains.....	203
TN-S power mains.....	203
Trace function.....	17
Transport.....	24, 260, 260
Trigger inputs.....	14, 241
Trigger options.....	18
TT power mains.....	203
Type of control cabinet installation.....	231
Type plate.....	23
Type tests.....	259

## V

Vertical offset.....	193
----------------------	-----

**W**

Warning label.....	26
Wire cross section - Protective ground wire.....	204
Wired safety technology.....	247
Wire types.....	245
Wiring	
DC bus.....	213
EnDat cable.....	173
General information.....	239
Motor cable.....	169
Power mains connection.....	206
Resolver cable.....	176
Working on servo drives.....	25

8AC110.60-2.....	102
8AC114.60-2.....	105
8AC120.60-1.....	108
8AC121.60-1.....	112
8AC122.60-3.....	115
8AC123.60-1.....	118
8AC125.60-1.....	122
8AC126.60-1.....	124
8AC130.60-1.....	127
8AC131.60-1.....	131
8AC140.60-3.....	135
8AC140.61-3.....	136
8AC141.60-2.....	146
8AC141.61-3.....	146
8B0W0045H000.000-1.....	157
8B0W0045H000.001-1.....	157
8B0W0079H000.000-1.....	157
8B0W0079H000.001-1.....	157
8CE005.12-1.....	172
8CE007.12-1.....	172
8CE010.12-1.....	172
8CE015.12-1.....	172
8CE020.12-1.....	172
8CE025.12-1.....	172
8CM005.12-0.....	160
8CM005.12-1.....	162
8CM005.12-3.....	164
8CM005.12-5.....	166
8CM005.12-8.....	168
8CM007.12-0.....	160
8CM007.12-1.....	162
8CM007.12-3.....	164
8CM007.12-5.....	166
8CM007.12-8.....	168
8CM010.12-0.....	160
8CM010.12-1.....	162
8CM010.12-3.....	164
8CM010.12-5.....	166
8CM010.12-8.....	168
8CM015.12-0.....	160
8CM015.12-1.....	162
8CM015.12-3.....	164
8CM015.12-5.....	166
8CM015.12-8.....	168
8CM020.12-0.....	160
8CM020.12-1.....	162
8CM020.12-3.....	164
8CM020.12-5.....	166
8CM020.12-8.....	168
8CM025.12-0.....	160
8CM025.12-1.....	162
8CM025.12-3.....	164
8CM025.12-5.....	166
8CM025.12-8.....	168
8CR005.12-1.....	175
8CR007.12-1.....	175
8CR010.12-1.....	175
8CR015.12-1.....	175
8CR020.12-1.....	175
8CR025.12-1.....	175
8PE001.00-1.....	180
8PM001.00-1.....	178

8PM002.00-1.....	178
8PM003.00-1.....	178
8PR001.00-1.....	181
8V1010.00-2.....	35
8V1010.001-2.....	35
8V1010.50-2.....	38
8V1010.501-2.....	38
8V1016.00-2.....	41
8V1016.001-2.....	41
8V1016.50-2.....	45
8V1016.501-2.....	45
8V1022.00-2.....	56
8V1022.001-2.....	56
8V1045.00-2.....	59
8V1045.001-2.....	59
8V1090.00-2.....	62
8V1090.001-2.....	62
8V1180.00-2.....	72
8V1180.001-2.....	72
8V128M.00-2.....	91
8V128M.001-2.....	91
8V1320.00-2.....	76
8V1320.001-2.....	76
8V1640.00-2.....	87
8V1640.001-2.....	87