

# PXI™

---

## PXI-8150B Series User Manual

## **Worldwide Technical Support and Product Information**

<http://www.natinst.com>

## **National Instruments Corporate Headquarters**

11500 North Mopac Expressway Austin, Texas 78759-3504 USA Tel: 512 794 0100

## **Worldwide Offices**

Australia 03 9879 5166, Austria 0662 45 79 90 0, Belgium 02 757 00 20, Brazil 011 284 5011,  
Canada (Ontario) 905 694 0085, Canada (Québec) 514 694 8521, Denmark 45 76 26 00,  
Finland 09 725 725 11, France 0 1 48 14 24 24, Germany 089 741 31 30, Hong Kong 2645 3186,  
India 91805275406, Israel 03 6120092, Italy 02 413091, Japan 03 5472 2970, Korea 02 596 7456,  
Mexico (D.F.) 5 280 7625, Mexico (Monterrey) 8 357 7695, Netherlands 0348 433466, Norway 32 84 84 00,  
Singapore 2265886, Spain (Madrid) 91 640 0085, Spain (Barcelona) 93 582 0251, Sweden 08 587 895 00,  
Switzerland 056 200 51 51, Taiwan 02 2377 1200, United Kingdom 01635 523545

For further support information, see the *Customer Communication* appendix of this manual.

© Copyright 1999 National Instruments Corporation. All rights reserved.

# Important Information

---

## Warranty

The PXI-8150B Series of embedded PXI computers are warranted against defects in materials and workmanship for a period of one year from the date of shipment, as evidenced by receipts or other documentation. National Instruments will, at its option, repair or replace equipment that proves to be defective during the warranty period. This warranty includes parts and labor.

The media on which you receive National Instruments software are warranted not to fail to execute programming instructions, due to defects in materials and workmanship, for a period of 90 days from date of shipment, as evidenced by receipts or other documentation. National Instruments will, at its option, repair or replace software media that do not execute programming instructions if National Instruments receives notice of such defects during the warranty period. National Instruments does not warrant that the operation of the software shall be uninterrupted or error free.

A Return Material Authorization (RMA) number must be obtained from the factory and clearly marked on the outside of the package before any equipment will be accepted for warranty work. National Instruments will pay the shipping costs of returning to the owner parts which are covered by warranty.

National Instruments believes that the information in this document is accurate. The document has been carefully reviewed for technical accuracy. In the event that technical or typographical errors exist, National Instruments reserves the right to make changes to subsequent editions of this document without prior notice to holders of this edition. The reader should consult National Instruments if errors are suspected. In no event shall National Instruments be liable for any damages arising out of or related to this document or the information contained in it.

EXCEPT AS SPECIFIED HEREIN, NATIONAL INSTRUMENTS MAKES NO WARRANTIES, EXPRESS OR IMPLIED, AND SPECIFICALLY DISCLAIMS ANY WARRANTY OF MERCHANTABILITY OR FITNESS FOR A PARTICULAR PURPOSE. CUSTOMER'S RIGHT TO RECOVER DAMAGES CAUSED BY FAULT OR NEGLIGENCE ON THE PART OF NATIONAL INSTRUMENTS SHALL BE LIMITED TO THE AMOUNT THEREFORE PAID BY THE CUSTOMER. NATIONAL INSTRUMENTS WILL NOT BE LIABLE FOR DAMAGES RESULTING FROM LOSS OF DATA, PROFITS, USE OF PRODUCTS, OR INCIDENTAL OR CONSEQUENTIAL DAMAGES, EVEN IF ADVISED OF THE POSSIBILITY THEREOF. This limitation of the liability of National Instruments will apply regardless of the form of action, whether in contract or tort, including negligence. Any action against National Instruments must be brought within one year after the cause of action accrues. National Instruments shall not be liable for any delay in performance due to causes beyond its reasonable control. The warranty provided herein does not cover damages, defects, malfunctions, or service failures caused by owner's failure to follow the National Instruments installation, operation, or maintenance instructions; owner's modification of the product; owner's abuse, misuse, or negligent acts; and power failure or surges, fire, flood, accident, actions of third parties, or other events outside reasonable control.

## Copyright

Under the copyright laws, this publication may not be reproduced or transmitted in any form, electronic or mechanical, including photocopying, recording, storing in an information retrieval system, or translating, in whole or in part, without the prior written consent of National Instruments Corporation.

## Trademarks

CVI™, LabVIEW™, NI-488.2™, NI-488.2M™, NI-DAQ™, NI-VISA™, PXI™, and TNT4882C™ are trademarks of National Instruments Corporation.

Product and company names mentioned herein are trademarks or trade names of their respective companies.

## WARNING REGARDING MEDICAL AND CLINICAL USE OF NATIONAL INSTRUMENTS PRODUCTS

National Instruments products are not designed with components and testing intended to ensure a level of reliability suitable for use in treatment and diagnosis of humans. Applications of National Instruments products involving medical or clinical treatment can create a potential for accidental injury caused by product failure, or by errors on the part of the user or application designer. Any use or application of National Instruments products for or involving medical or clinical treatment must be performed by properly trained and qualified medical personnel, and all traditional medical safeguards, equipment, and procedures that are appropriate in the particular situation to prevent serious injury or death should always continue to be used when National Instruments products are being used. National Instruments products are NOT intended to be a substitute for any form of established process, procedure, or equipment used to monitor or safeguard human health and safety in medical or clinical treatment.

# Compliance

---

## FCC/DOC Radio Frequency Interference Class A Compliance

This equipment generates and uses radio frequency energy and, if not installed and used in strict accordance with the instructions in this manual, may cause interference to radio and television reception. Classification requirements are the same for the Federal Communications Commission (FCC) and the Canadian Department of Communications (DOC). This equipment has been tested and found to comply with the following two regulatory agencies:

### Federal Communications Commission

This equipment has been tested and found to comply with the limits for a Class A digital device, pursuant to part 15 of the FCC Rules. These limits are designed to provide reasonable protection against harmful interference when the equipment is operated in a commercial environment. This equipment generates, uses, and can radiate radio frequency energy and, if not installed and used in accordance with the instruction manual, may cause harmful interference to radio communications. Operation of this equipment in a residential area is likely to cause harmful interference in which case the user will be required to correct the interference at his own expense.

**Notices to User:** *Changes or modifications not expressly approved by National Instruments could void the user's authority to operate the equipment under the FCC Rules.*

*This device complies with the FCC rules only if used with shielded interface cables of suitable quality and construction. National Instruments used such cables to test this device and provides them for sale to the user. The use of inferior or nonshielded interface cables could void the user's authority to operate the equipment under the FCC rules.*

If necessary, consult National Instruments or an experienced radio/television technician for additional suggestions. The following booklet prepared by the FCC may also be helpful: *Interference to Home Electronic Entertainment Equipment Handbook*. This booklet is available from the U.S. Government Printing Office, Washington, DC 20402.

### Canadian Department of Communications

This Class A digital apparatus meets all requirements of the Canadian Interference-Causing Equipment Regulations.

Cet appareil numérique de la classe A respecte toutes les exigences du Règlement sur le matériel brouilleur du Canada.

# Contents

---

## About This Manual

Organization of This Manual .....	ix
Conventions Used in This Manual.....	x
How to Use This Documentation Set .....	xi
Acrobat (Online) Documentation .....	xi
Related Documentation.....	xi
Customer Communication .....	xii

## Chapter 1

### Introduction

Overview.....	1-1
Hardware Description .....	1-3
Benefits of PXI.....	1-3
PXI-8150B Series Design.....	1-3
PXI-8150B Series Models.....	1-4
Memory .....	1-4
System Slot Functionality.....	1-4
Custom Application-Specific Interface Chips.....	1-5
Front Panel Features .....	1-5
Peripheral Expansion.....	1-6
PXI-1020 and PXI-1025 Chassis Support.....	1-7
PXI-1020 Chassis.....	1-7
Optional Equipment .....	1-7
National Instruments Software .....	1-7

## Chapter 2

### Functional Overview

PXI-8150B Functional Description .....	2-1
--	-----

## Chapter 3

### PXI-8150B Series Configuration and Installation

Default Settings.....	3-1
Configuring the PXI-8150B Series.....	3-4
Installed System RAM .....	3-4
System CMOS .....	3-4
Ethernet Power-on Defaults .....	3-5
LCD Output (PXI-1020 Chassis) .....	3-5

LCD Resolution .....	3-6
Keyboard and Mouse .....	3-6
Serial IRQ, INTP, and INTS .....	3-7
Onboard Video .....	3-8
Installing the PXI-8150B Series .....	3-8
How to Remove the Unit from the PXI Mainframe.....	3-11

## **Chapter 4**

### **BIOS**

Entering BIOS Setup .....	4-1
Default BIOS Setup Settings .....	4-1
Updating the BIOS .....	4-1

## **Appendix A**

### **Specifications**

## **Appendix B**

### **PXI-8150B Series System Resources**

## **Appendix C**

### **LED Indicators**

## **Appendix D**

### **Front Panel and Connectors**

## **Appendix E**

### **Common Questions**

## **Appendix F**

### **Customer Communication**

## **Glossary**

## **Index**

## Figures

Figure 1-1.	PXI-8155B Embedded Computer .....	1-1
Figure 1-2.	PXI-8156B Embedded Computer .....	1-2
Figure 2-1.	PXI-8150B Series Block Diagram .....	2-2
Figure 3-1.	PXI-8150B Series I/O Board Parts Locator Diagram .....	3-3
Figure 3-2.	PXI-8150B Series CPU Board Parts Locator Diagram.....	3-3
Figure 3-3.	System CMOS .....	3-4
Figure 3-4.	Ethernet Power-on Defaults .....	3-5
Figure 3-5.	LCD Output Settings .....	3-5
Figure 3-6.	LCD Resolution Setting .....	3-6
Figure 3-7.	Active Keyboard Port .....	3-6
Figure 3-8.	Active Mouse Port.....	3-6
Figure 3-9.	INTP Configuration.....	3-7
Figure 3-10.	INTS Configuration.....	3-7
Figure 3-11.	Onboard Video .....	3-8
Figure 3-12.	PXI-8156B Installed in a PXI Mainframe.....	3-10
Figure D-1.	PXI-8155B Front Panel Layout and Dimensions.....	D-2
Figure D-2.	PXI-8156B Front Panel Layout and Dimensions.....	D-3
Figure D-3.	Keyboard and Mouse Connectors Location and Pinout.....	D-4
Figure D-4.	VGA Connector Location and Pinout .....	D-5
Figure D-5.	Ethernet Connector Location and Pinout .....	D-6
Figure D-6.	COM1 and COM2 Connectors Location and Pinout .....	D-7
Figure D-7.	Parallel Port Connector Location and Pinout .....	D-8
Figure D-8.	GPIB Connector Location and Pinout.....	D-10
Figure D-9.	USB Connector Location and Pinout .....	D-11
Figure D-10.	PXI Connectors Location and Pinout .....	D-12

## Tables

Table 1-1.	PXI-8150B Series Peripherals Overview .....	1-6
Table 3-1.	PXI-8150B Series Hardware Default Settings .....	3-1
Table B-1.	PXI-8150B Series ISA Interrupt Resource Allocations .....	B-1
Table B-2.	PXI-8150B Series DMA Channel Resource Allocations .....	B-2
Table B-3.	PXI-8150B Series I/O Address Map .....	B-3
Table D-1.	Keyboard and Mouse Connector Signals .....	D-4
Table D-2.	VGA Connector Signals .....	D-5
Table D-3.	Ethernet Connector Signals .....	D-7
Table D-4.	COM1 and COM2 Connector Signals .....	D-8
Table D-5.	Parallel Port Connector Signals .....	D-9
Table D-6.	GPIB Connector Signals .....	D-10
Table D-7.	USB Connector Signals .....	D-11
Table D-8.	P2 Connector Pinouts for the System Controller Slot .....	D-13
Table D-9.	P1 Connector Pinouts for the System Controller Slot .....	D-14



# About This Manual

---

This manual contains detailed instructions for installing and configuring your National Instruments PXI-8150B Series embedded computer kit. The PXI-8150B Series includes all the models of the PXI-8155B and PXI-8156B embedded PXI computers.

## Organization of This Manual

---

This manual is organized as follows:

- Chapter 1, *Introduction*, describes the PXI-8150B Series of embedded PXI computers and lists optional equipment and software.
- Chapter 2, *Functional Overview*, contains functional descriptions of each major logic block on the PXI-8150B Series embedded computers.
- Chapter 3, *PXI-8150B Series Configuration and Installation*, contains the instructions for configuring and installing the PXI-8150B Series embedded computer.
- Chapter 4, *BIOS*, contains information on BIOS, the low-level interface between the hardware and PC software that configures and tests your hardware when you start up the system.
- Appendix A, *Specifications*, lists the electrical, mechanical, and environmental specifications of the PXI-8150B Series embedded computer, and describes how to add RAM.
- Appendix B, *PXI-8150B Series System Resources*, describes the system resources available on the PXI-8150B Series embedded computer and where they are allocated.
- Appendix C, *LED Indicators*, describes how to interpret the status of the PXI-8150B Series computer by reading the LEDs on the front panel.
- Appendix D, *Front Panel and Connectors*, describes the front panel and connectors on the PXI-8150B Series embedded computer.
- Appendix E, *Common Questions*, answers common questions you may have when using the PXI-8150B Series embedded computer.
- Appendix F, *Customer Communication*, contains forms you can use to request help from National Instruments or to comment on our products and manuals.

- The *Glossary* contains an alphabetical list and description of terms used in this manual, including abbreviations, acronyms, metric prefixes, mnemonics, and symbols.
- The *Index* contains an alphabetical list of key terms and topics used in this manual, including the page where you can find each one.

## Conventions Used in This Manual

---

The following conventions are used in this manual:

< >

Angle brackets enclose the name of a key on the keyboard (for example, <DEL>).



This icon to the left of bold italicized text denotes a note, which alerts you to important information.



This icon to the left of bold italicized text denotes a caution, which advises you of precautions to take to avoid injury, data loss, or a system crash.



This icon to the left of bold italicized text denotes a warning, which advises you of precautions to take to avoid being electrically shocked.

**bold**

Bold text denotes the names of menus, menu items, dialog box buttons or options, or LEDs.

***bold italic***

Bold italic text denotes a note, caution, or warning.

**bold monospace**

Bold text in this font denotes the messages and responses that the computer automatically prints to the screen.

*italic*

Italic text denotes emphasis, a cross reference, or an introduction to a key concept.

monospace

Text in this font denotes the proper names of disk drives, paths, directories, filenames, and extensions.

PXI-8150B Series

The terms *PXI-8150B Series* and *PXI-8150B* refer to a series of 3U PXI controllers. Currently, this series consists of the PXI-8155B and PXI-8156B, with various processors and in different speeds.

# How to Use This Documentation Set

---

Begin by reading *Getting Started with Your PXI-8150B Series for Windows NT/98*, a brief quick-start manual that describes how to set up and get started with your kit using the default settings.

This manual, the *PXI-8150B Series User Manual*, contains more details about changing the installation or configuration from the defaults, and about using the hardware.

PXI-8156B users receive the NI-488.2M software kit, which includes the *NI-488.2M User Manual for Windows 95 and Windows NT* and the *NI-488.2M Function Reference Manual for Win32*.

If you ordered either LabVIEW or LabWindows/CVI, you received full documentation along with a configuration disk to unlock and access these application programming environments, which are already installed on your hard drive.

## Acrobat (Online) Documentation

To learn more about using NI-VISA your kit includes online manuals in the form of Adobe Acrobat version 3.0 portable document format (PDF) files. The Acrobat manuals and their installed locations are as follows.

- The *NI-VISA User Manual* describes how to program using NI-VISA:  
**Start»Programs»VXIpn»NI-VISA User Manual**
- The *NI-VISA Programmer Reference Manual* describes in detail the attributes, events, and operations you use in NI-VISA:  
**Start»Programs»VXIpn»NI-VISA Programmer Reference Manual**

If you do not have Adobe Acrobat Reader 3.0, you can download a copy from the Adobe Web site at <http://www.adobe.com/>.

## Related Documentation

---

The following documents contain information you may find helpful as you read this manual:

- *PICMG 2.0 R2.1 CompactPCI Specification*, PCI Industrial Computers Manufacturers Group
- IEEE Standard P1284.1-1997 (*C/MM*) *Standard for Information Technology for Transport Independent Printer/System Interface*

- *PCI Local Bus Specification*, Revision 2.1, PCI Special Interest Group
- *PXI Specification*, Revision 1.0, National Instruments Corporation
- *Serialized IRQ Support for PCI Systems Specification*, Revision 6.0, Compaq Computer et al.

## Customer Communication

---

National Instruments wants to receive your comments on our products and manuals. We are interested in the applications you develop with our products, and we want to help if you have problems with them. To make it easy for you to contact us, this manual contains comment and configuration forms for you to complete. These forms are in Appendix F, [Customer Communication](#), at the end of this manual.

---

# Introduction

This chapter describes the PXI-8150B Series of embedded PXI computers and lists optional equipment and software.

## Overview

---

The PXI-8150B Series consists of the PXI-8155B and the PXI-8156B PXI system controllers, as shown in the following illustrations. Refer to Appendix D, *Front Panel and Connectors*, to determine the purpose for each connector on the module. Figure 1-1 shows a PXI-8155B model.

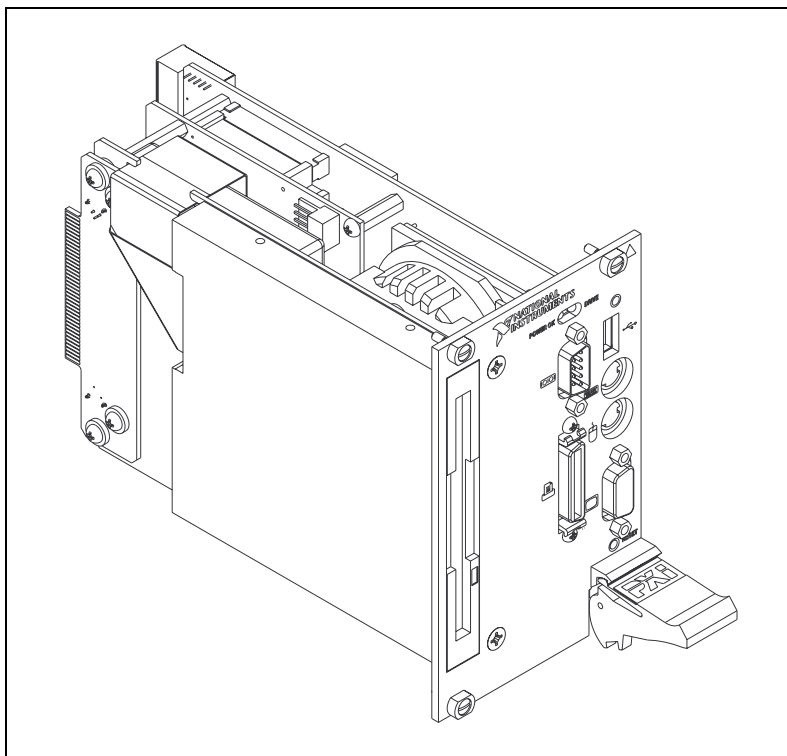

**Figure 1-1.** PXI-8155B Embedded Computer

Figure 1-2 shows a PXI-8156B model.

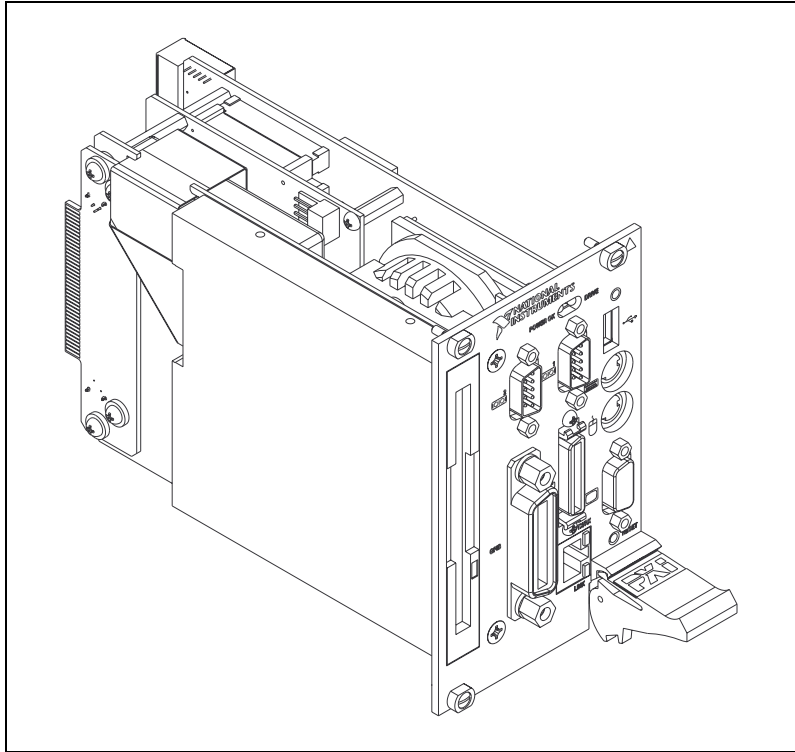

**Figure 1-2.** PXI-8156B Embedded Computer

The PXI-8150B Series controllers are 3U PXI/CompactPCI embedded computers based on the Peripheral Component Interface (PCI) bus and Industry Standard Architecture (ISA). These computers are high-performance, easy-to-use platforms for controlling PCI systems, featuring complete PXI (PCI eXtensions for Instrumentation) functionality through interactive utilities and C function calls. In addition, the PXI-8156B has Ethernet capability plus an IEEE 488.2 interface that is compatible with the NI-488.2 architecture.

The PXI-8150B Series is a custom computer that you install directly in the system controller slot of your PXI mainframe. An embedded computer can take full advantage of the PXI high-performance backplane capabilities.

All models in the PXI-8150B Series are compatible with PC-compatible software tools, the National Instruments LabVIEW and LabWindows/CVI application software, and the NI-VISA, NI-488.2M, and NI-DAQ software.

## Hardware Description

---

### Benefits of PXI

The PXI-8150B Series PXI/CompactPCI embedded computers are high-performance CompactPCI-compatible system controllers that are compatible with the PXI bus specification. PXI defines a compact modular PC platform for industrial instrumentation. PXI leverages the PCI bus, which is the *de facto* standard for today's desktop computer software and hardware designs. As a result, PXI users receive all the benefits of PCI within an architecture that supports mechanical, electrical, and software features tailored to industrial instrumentation, data acquisition, and automation applications.

Well-suited for industrial applications, PXI leverages from the CompactPCI specification, which defines a rugged form factor for PCI that offers superior mechanical integrity and easy installation and removal of hardware components. PXI products offer higher and more carefully defined levels of environmental performance required by the vibration, shock, temperature, and humidity extremes of industrial environments. PXI adds mandatory environmental testing and active cooling to the CompactPCI mechanical specification to ease system integration and ensure multivendor interoperability.

Additionally, PXI meets the more specific needs of instrumentation users by adding an integrated trigger bus and reference clock for multiple-board synchronization, a star trigger bus for very precise timing, and local buses for side-band communication between adjacent peripherals.

### PXI-8150B Series Design

The PXI-8150B Series PXI embedded computers are high-performance PXI system controllers with all the standard I/O features built in. The PXI-8150B Series uses state-of-the-art technology and packaging to create a fully PC-compatible controller for PXI. Due to the unique design and packaging, these computers have onboard PCI video and are still able to connect to the PXI bus without the need of a PCI-to-PCI bridge. As a result, they preserve the full 132 Mbytes/s PCI bandwidth for other PXI boards. In addition, the PXI-8150B supports masters in all seven available PXI slots.

The PXI-8150B Series design includes many standard PC peripherals, which means you can install your custom-designed peripheral devices in all PXI slots. It also has two user-accessible SO-DIMM sockets so it is easy to upgrade memory. The unique packaging includes a built-in 1.44 MB floppy drive and 2.5 in. hard drive. The mechanical assembly of the PXI-8150B mounts these devices to the PXI-8150B main board so you can remove the entire unit intact. This eases integration issues and cabling. The PXI-8150B plugs directly into the system controller slot and expands to the left, thus preserving all usable PXI slots for user-defined peripheral devices.

## PXI-8150B Series Models

Currently the PXI-8150B Series consists of two models—the PXI-8155B and the PXI-8156B. Both models have two CPU choices—a 233 MHz or 333 MHz MMX processor.

The models differ in the front-panel I/O. The PXI-8155B comes complete with a 3.5 in. 1.44 MB floppy drive, 4 GB hard drive or larger, Super VGA with 2 MB SGRAM, a serial port, an IEEE 1284 parallel port, a PS/2 keyboard and mouse, a USB connector, and software installed. The PXI-8156B adds a second serial port, a 10BaseT Ethernet port, and an IEEE 488.2 (GPIB) interface compatible with the National Instruments AT-GPIB/TNT.

## Memory

The PXI-8150B and its memory sockets are easily accessible so you can install additional DRAM in the field. You can install up to 256 MB of 10 ns SDRAM, using 144-pin SO-DIMMS.

The PXI-8150B contains at least a 4 GB internal, enhanced IDE hard disk. For information on adding RAM by installing SO-DIMMs, refer to Appendix A, [Specifications](#).

## System Slot Functionality

You can use the PXI-8150B Series computers to achieve full PXI system slot control of your PXI system. In the system slot, the PXI-8150B provides master/slave capabilities to all slots in the PXI system.



## Custom Application-Specific Interface Chips

The PXI-8156B has the TNT4882C custom ASIC to give full GPIB control of external instruments via a front-panel connector. GPIB capability is fully compatible with IEEE 488.2 and the industry-standard NI-488.2M driver for a variety of operating systems.

## Front Panel Features

The PXI-8150B Series has the following front-panel features:

- Internal 3.5 in. floppy drive
- System reset push-button
- Front-panel connectors:
  - RS-232 Serial (one on PXI-8155B, two on PXI-8156B)
  - Extended Capabilities Parallel (ECP)
  - VGA Controller
  - Universal Serial Bus (USB)
  - PS/2-style keyboard
  - PS/2-style mouse
  - GPIB (PXI-8156B only)
  - 10BaseT Ethernet (PXI-8156B only)
- Two front-panel LEDs that show PC status
  - **POWER OK** LED indicates that the power is on and reset is no longer asserted.
  - **DRIVE** LED indicates when an access to the internal hard disk is occurring.
- Two front-panel LEDs that show Ethernet port status (PXI-8156B Series only)
  - **TX/RX** LED indicates that the PXI-8156B is receiving or transmitting a packet of data through its Ethernet port.
  - **LINK** LED indicates periodic link test passed.

## Peripheral Expansion

The PXI-8150B uses the PCI local bus and ISA bus for peripheral expansion. The PCIbus is a 32-bit multimaster bus that achieves a top throughput of 132 Mbytes/s and can handle numerous peripherals. The ISA bus is the legacy peripheral bus found on current and older PCs.

For information on installing and configuring these peripherals for use with the PXI-8150B, refer to the `C:\Images\Pxi815xB` directory. The `drivers.txt` file explains how to install support for each peripheral. This directory also contains manufacturers' documentation for the peripherals. Also refer to the `readme` files for the most up-to-date information.

Table 1-1 lists the various peripherals and describes the external connector, its bus interface, and its function.

**Table 1-1.** PXI-8150B Series Peripherals Overview

Peripheral	External Connector	ISA or PCI	Function
Video	15-pin DSUB (standard VGA)	PCI	High-resolution/ color support for a Super VGA monitor
IDE	None	PCI	Supports internal fast ATA-3 hard drive
Ethernet	RJ-45	ISA	10BaseT Ethernet connection
GPIB	24-pin standard GPIB connector	ISA	IEEE 488.2 interface compatible with the National Instruments AT-GPIB/TNT
Serial	Serial Port (9-pin DSUB)	ISA	16550 serial ports
Parallel	Parallel Port (IEEE 1284)	ISA	Extended capabilities
USB	4-pin Series A receptacle	PCI	Universal Serial Bus
Keyboard/Mouse	PS/2	ISA	PS/2-style keyboard and mouse
Watchdog Timer	None	ISA	Indicates when timer is not refreshed

## PXI-1020 and PXI-1025 Chassis Support

The PXI-8150B Series controller is designed to directly interface to PXI-1020 and PXI-1025 chassis. This interface contains the signals required to control a TFT LCD, an IDE device, a PS/2 keyboard, and a PS/2 mouse.

Because the keyboard/mouse controller on the PXI-8150B Series supports only one keyboard and one mouse at a time, the controller has two switches you can use to control whether to enable either the keyboard and mouse ports on the front panel of the PXI-8150B or the built-in chassis devices. Refer to the *Keyboard and Mouse* section in Chapter 3, *PXI-8150B Series Configuration and Installation*, for switch settings.

### PXI-1020 Chassis

The PXI-1020 chassis currently does not contain a built-in keyboard.

When using the PXI-8150B Series controller with the PXI-1020 chassis, the LCD may be dimmed through software. The software is located on your hard drive in the `C:\Images\PXI815xB\LCD` directory. Also, with this chassis you can select whether the LCD is enabled while booting or off until the operating system loads and software turns it on. Refer to the *LCD Output* section in Chapter 3, *PXI-8150B Series Configuration and Installation*, for the jumper settings.

## Optional Equipment

---

You can contact National Instruments to order the following optional equipment:

- Enhanced parallel port adapter cable
- Single-shielded 2 m GPIB cable

## National Instruments Software

---

National Instruments has developed several software kits that you can use with the PXI-8150B Series. The software is already installed on your hard drive.

The NI-488.2M software kit gives you access to the industry-standard NI-488.2M software for controlling external GPIB instruments through the GPIB port on the front panel of the PXI-8150B. The GPIB interface is fully compatible with the NI-488.2M driver for a variety of operating systems.

Any GPIB application using NI-488.2M or NI-VISA will run on the PXI-8156B.

NI-DAQ has an extensive library of functions that you can call from your application programming environment. These functions include routines for analog input (A/D conversion), buffered data acquisition (high-speed A/D conversion), analog output (D/A conversion), waveform generation, digital I/O, counter/timer operations, SCXI, RTSI, self-calibration, messaging, and acquiring data to extended memory.

NI-VISA is the National Instruments implementation of the VISA specification. VISA is a uniform API for communicating and controlling Serial, GPIB, PXI, VXI, and various other types of instruments. This API aids in the creation of more portable applications and instrument drivers. For information on writing your own PXI instrument driver with NI-VISA, see the NI-VISA *Getting Started* manual and the `readme.txt` file in the NI-VISA directory.

You can also use the National Instruments LabVIEW and LabWindows/CVI application programs and instrument drivers to ease your programming task. These standardized programs match the modular virtual instrument capability of PXI and can reduce your PXI software development time. These programs feature extensive libraries of GPIB, Serial, and VXI instrument drivers written to take full advantage of direct PXI control. LabVIEW and LabWindows/CVI include all the tools needed for instrument control, data acquisition, analysis, and presentation.

LabVIEW is a complete programming environment that departs from the sequential nature of traditional programming languages and features a graphical programming environment.

LabWindows/CVI is an interactive C development environment for building test and measurement and instrument control systems. It includes interactive code-generation tools and a graphical editor for building custom user interfaces.

---

## Functional Overview

This chapter contains functional descriptions of each major logic block on the PXI-8150B Series embedded computers.

### PXI-8150B Functional Description

---

The PXI-8150B is a modular PC in a PXI 3U-size form factor. It includes many high-performance peripherals that normally require add-in cards on desktop PCs.

Figure 2-1 is a functional block diagram of the PXI-8150B Series. Following the diagram is a description of each logic block shown.

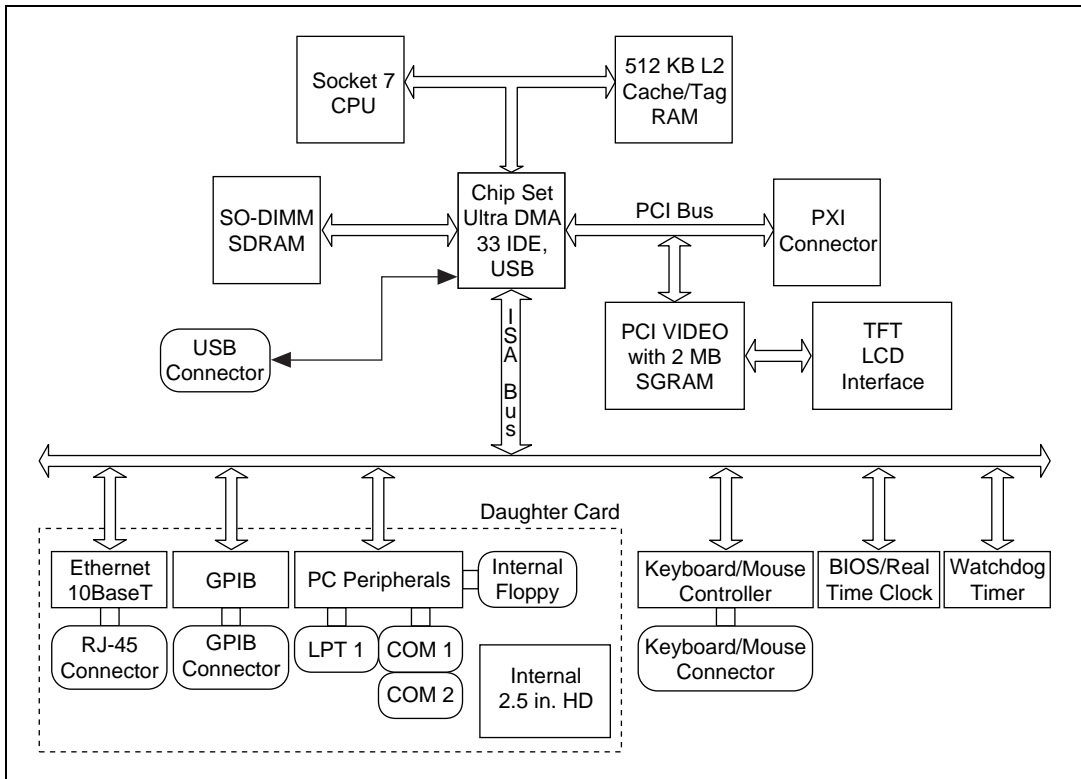

**Figure 2-1.** PXI-8150B Series Block Diagram

The PXI-8150B consists of the following logic blocks on the CPU module and the I/O (daughter card) module. The CPU module has the following logic blocks:

- *Socket 7 CPU* is the socket definition for the Intel Pentium Processor family.
- The *L2 Cache/Tag* block consists of 512 KB of Pipeline Burst SRAM.
- The *SO-DIMM* block consists of two 64-bit SDRAM sockets that can hold up to 128 MB each.
- The *Chip Set* block consists of the chip set that connects the CPU to cache and the DRAM. The chip set also contains the USB interface and the IDE interface.

- The *PCI video circuitry* is a PCI-based design that has a 64-bit data path to up to 2 MB of SGRAM. It also contains a *TFT LCD Interface* which is used in the National Instruments PXI-1020 and PXI-1025 chassis, and supports Windows 98 dual display: LCD and CRT.
- The *USB connector* connects the chip set to the Universal Serial Bus interface.
- The *PXI connector* connects the PXI-8150B to the PXI/CompactPCI backplane.
- The *Keyboard/Mouse* block contains the PS/2 keyboard and mouse interface.
- The *BIOS/RTC* block contains the boot BIOS and the Real Time Clock interface.
- The *Watchdog Timer* block is the circuitry that, once configured, signals if the timer is not refreshed. Refer to the `drivers.txt` file located in the `C:\Images\PXI815xB` directory for more information on configuring and using the watchdog timer.

The daughter card module has the following logic blocks:

- The *Ethernet* block on the PXI-8156B is an ISA-based Ethernet circuit. It uses an RJ-45 connector for access to an external Ethernet-based LAN.
- The *GPIB* logic block represents the IEEE 488.2 port on the PXI-8156B model. It uses the National Instruments TNT4882 ASIC for maximum performance as an ISA-based GPIB controller.
- The *PC Peripherals* blocks represent the other peripherals supplied by the PXI-8150B Series. The PXI-8155B has one serial port, an ECP/EPP parallel port, and a 1.44 MB, 3.5 in. floppy drive. The PXI-8156B adds a second serial port.
- The *IDE* block is dedicated PCI-IDE circuitry providing fast ATA-3 transfers to the internal hard drive. The IDE feature is built into the chip set.

# PXI-8150B Series Configuration and Installation

This chapter contains the instructions for configuring and installing the PXI-8150B Series embedded computer. Unless otherwise noted, these instructions apply to all models in the PXI-8150B Series, which currently consists of the PXI-8155B and the PXI-8156B.



**Caution** *Electrostatic discharge can damage several components on your PXI-8150B module. To avoid such damage in handling the module, touch the antistatic plastic package to a metal part of your PXI mainframe before removing the module from the package.*

## Default Settings

This section summarizes the hardware default settings for the PXI-8150B Series for easy reference. The module is set at the factory for the most commonly used configuration.

Table 3-1 lists the factory-default settings and options for the onboard jumpers and switches. Five of the jumpers and two switches are located on the CPU board, and three jumpers are on the I/O board.

**Table 3-1.** PXI-8150B Series Hardware Default Settings

Jumper/Switch	Default Setting	Optional Setting
W1 (CPU Board) CMOS Clear	Disabled (Normal CMOS operation)	Clear CMOS
W2 (CPU Board) INTP Connection	No Connection to INTP	IRQ14
W3 (CPU Board) INTS Connection	Serial IRQ Connected to INTS	a. No Connection b. IRQ15
W14 (CPU Board) Onboard video	Enabled	Disabled



**Table 3-1.** PXI-8150B Series Hardware Default Settings (Continued)

<b>Jumper/Switch</b>	<b>Default Setting</b>	<b>Optional Setting</b>
W17 (CPU Board) LCD Resolution	640 × 480	800 × 600
S1 (CPU Board) Active Keyboard Port	PXI-8150B Controller Front Panel Keyboard Port	Chassis Keyboard (if available)
S2 (CPU Board) Active Mouse Port	PXI-8150B Controller Front Panel Mouse Port	Chassis Mouse (if available)
W1 (I/O Board) Ethernet EEPROM (PXI-8156B only)	Enable Ethernet EEPROM configuration	Do not alter the default setting.
W3 (I/O Board) LCD Display Output on Boot	ON	OFF until software enabled
W4 (I/O Board) LCD Display Output on Boot	ON	OFF until software enabled

Figures 3-1 and 3-2 show the location and factory-default settings of the configuration switches and jumpers on the PXI-8150B Series.

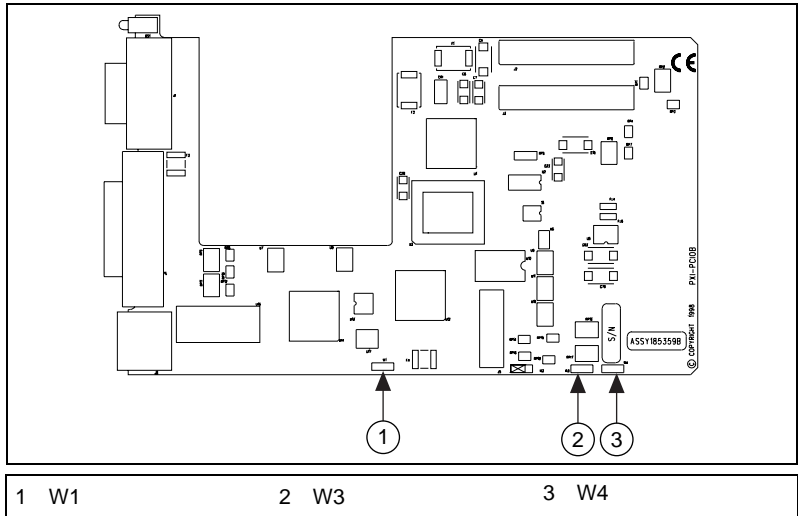

**Figure 3-1.** PXI-8150B Series I/O Board Parts Locator Diagram

Figure 3-2 shows the CPU board.

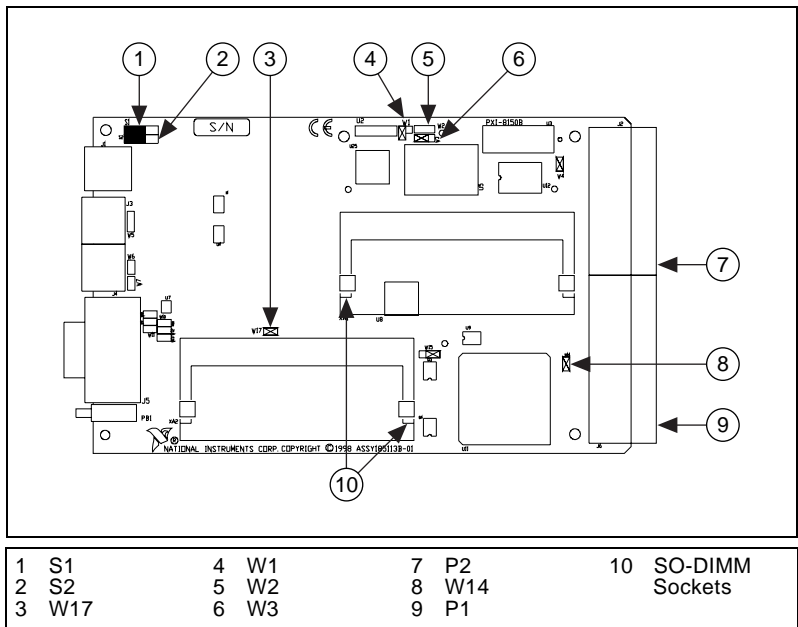

**Figure 3-2.** PXI-8150B Series CPU Board Parts Locator Diagram

## Configuring the PXI-8150B Series

This section describes how to configure the following options.

- System RAM
- System CMOS
- Ethernet power-on defaults
- LCD output
- LCD resolution
- Keyboard and mouse ports
- Serial IRQ, INTP and INTS connection
- Onboard Video

### Installed System RAM

You can change the amount of installed RAM on the PXI-8150B Series by installing DRAM SO-DIMMs. Refer to Appendix A, *Specifications*, for more information on SO-DIMMs.

### System CMOS

The PXI-8150B contains a backed-up memory used to store BIOS defaults and configuration information.

To clear the CMOS contents, short the pins of W1 as shown in Figure 3-3b. Plug the unit back into the mainframe and apply power momentarily. Turn the power back off and remove the unit. Place the jumper back in the default state.



**Caution** *Do not keep these two pins short-circuited. The computer cannot sustain the CMOS memory when the power is turned off if you leave these two pins shorted.*

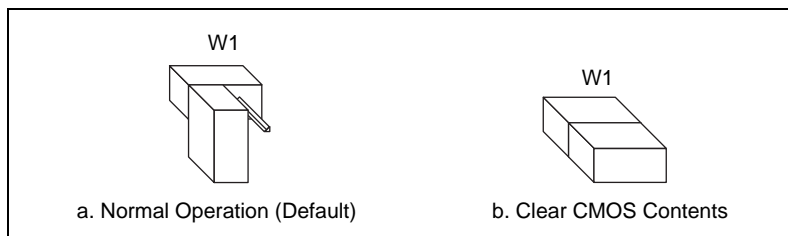

**Figure 3-3.** System CMOS

## Ethernet Power-on Defaults

The PXI-8150B Ethernet circuitry loads its power-on settings from an EEPROM. Do not change switch W1 from its default setting as shown in Figure 3-4a. Figure 3-4b shows the alternate position only for informational purposes.

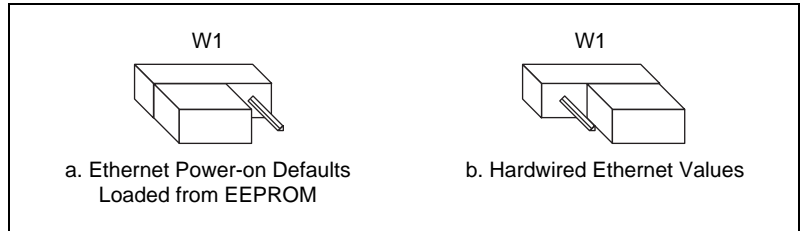

**Figure 3-4.** Ethernet Power-on Defaults

## LCD Output (PXI-1020 Chassis)

When using the PXI-8150B Series controller with an PXI-1020 chassis, you can select whether the LCD is enabled while booting or off until the operating system loads and software turns it on. Use both the W3 and W4 jumpers to change the LCD output settings. Figure 3-5 shows the LCD output configuration options.

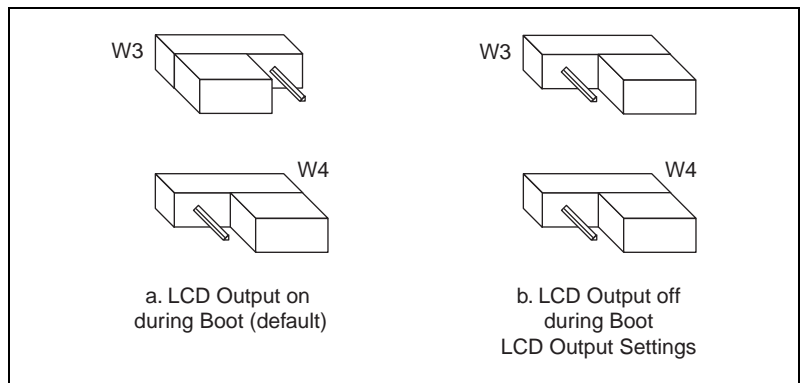

**Figure 3-5.** LCD Output Settings

## LCD Resolution

The LCD output resolution can be switched between 640 × 480 and 800 × 600. Figure 3-6 shows the LCD resolution options.

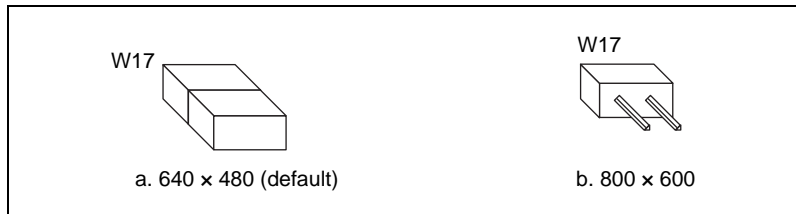

**Figure 3-6.** LCD Resolution Setting

## Keyboard and Mouse

Two switches—S1 and S2— control whether to enable the PS/2 keyboard and mouse ports on the front panel of the PXI-8150B controller or the built-in chassis devices, if available. By default, both front panel ports are enabled. Change S1 to use a chassis keyboard port and S2 to use a chassis mouse port.



**Note**

*Only the PXI-1020 and PXI-1025 chassis currently have built-in PS/2 devices that can be selected in this manner.*

Figures 3-7 and 3-8 show the keyboard and mouse options, respectively.

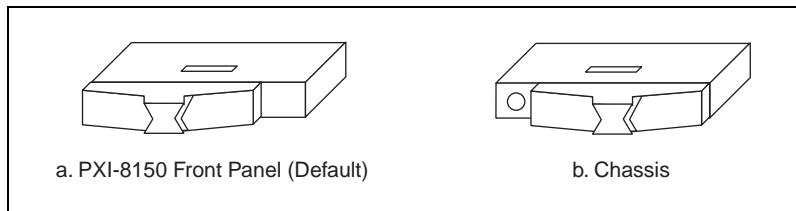

**Figure 3-7.** Active Keyboard Port

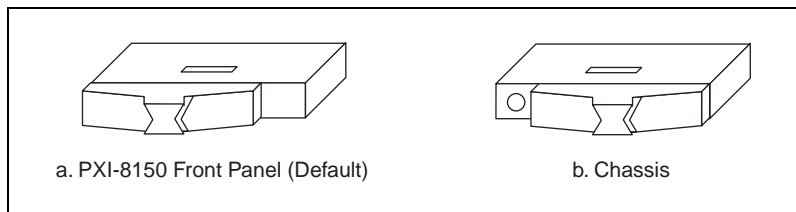
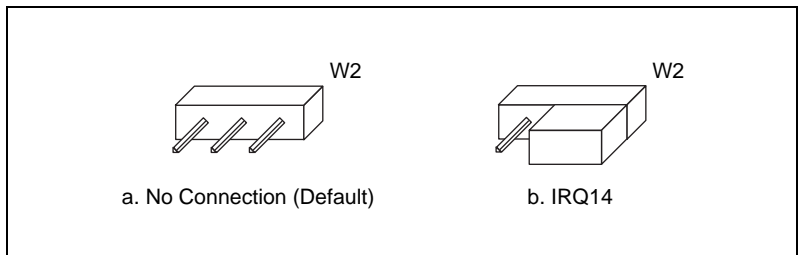

**Figure 3-8.** Active Mouse Port

## Serial IRQ, INTP, and INTS

You can use jumper settings on the PXI-8150B Series to connect INTP on the PXI backplane to IRQ14 as well as INTS to either IRQ15 or to serial IRQ. Refer to the documentation that comes with your PXI peripheral device to see if you need to make any changes from the default settings. For more information on Serial IRQ, refer to the *Serialized IRQ Support for PCI Systems Specification*.

Figure 3-9 shows the INTP configuration options and Figure 3-10 shows the INTS configuration options.



**Figure 3-9.** INTP Configuration

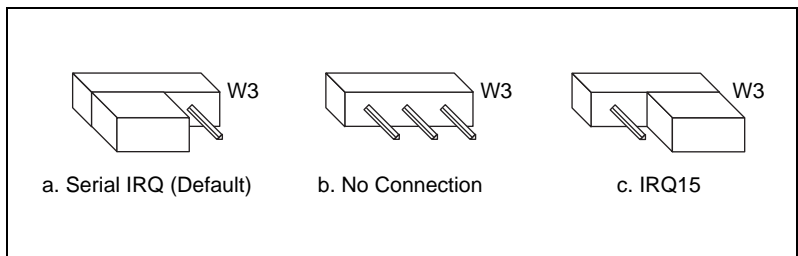

**Figure 3-10.** INTS Configuration

## Onboard Video

The onboard video can be disabled to allow the use of a CPCI or PXI video card. Figure 3-11 shows the onboard video configuration options

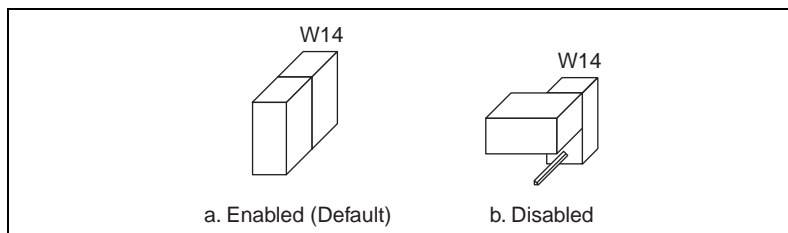

**Figure 3-11.** Onboard Video

## Installing the PXI-8150B Series

This section contains general installation instructions for the PXI-8150B. Consult your PXI mainframe user manual for specific instructions and warnings.

1. Plug in your mainframe before installing the PXI-8150B. The power cord grounds the mainframe and protects it from electrical damage while you install the module.



**Warning** *To protect both yourself and the mainframe from electrical hazards, leave the mainframe off until you finish installing the PXI-8150B module.*

2. Remove or open any doors or covers blocking access to the system controller slot (Slot 1) in the mainframe.
3. Touch the metal part of the case to discharge any static electricity that might be on your clothes or body.
4. Make sure the injector/ejector handle is in its downward position. Align the PXI-8150B with the card guides on the top and bottom of the system controller slot.



**Caution** *Do not raise the injector/ejector handle as you insert the PXI-8150B. The module will not insert properly unless the handle is in its downward position so that it does not interfere with the injector rail on the mainframe.*

5. Hold the handle as you slowly slide the module into the mainframe until the handle catches on the injector/ejector rail.

6. Raise the injector/ejector handle until the module firmly seats into the backplane receptacle connectors. The front panel of the PXI-8150B should be even with the front panel of the mainframe.
7. Tighten the four bracket-retaining screws on the top and bottom of the front panel to secure the PXI-8150B to the mainframe.
8. Check the installation.
9. Connect the keyboard and mouse to the appropriate connectors. Use the keyboard adapter cable that you received with your kit if you need to adapt an AT-style keyboard to the PXI-8150B mini-DIN connector.
10. Connect the VGA monitor video cable to the VGA connector.
11. Connect devices to ports as required by your system configuration. Some ports, such as the Parallel port, have adapter cables that you can order from National Instruments.
12. Replace or close any doors or covers to the mainframe.



Figure 3-12 shows a PXI-8156B installed in the system controller slot of a National Instruments PXI-1000 mainframe. You can place PXI devices in any other slot.

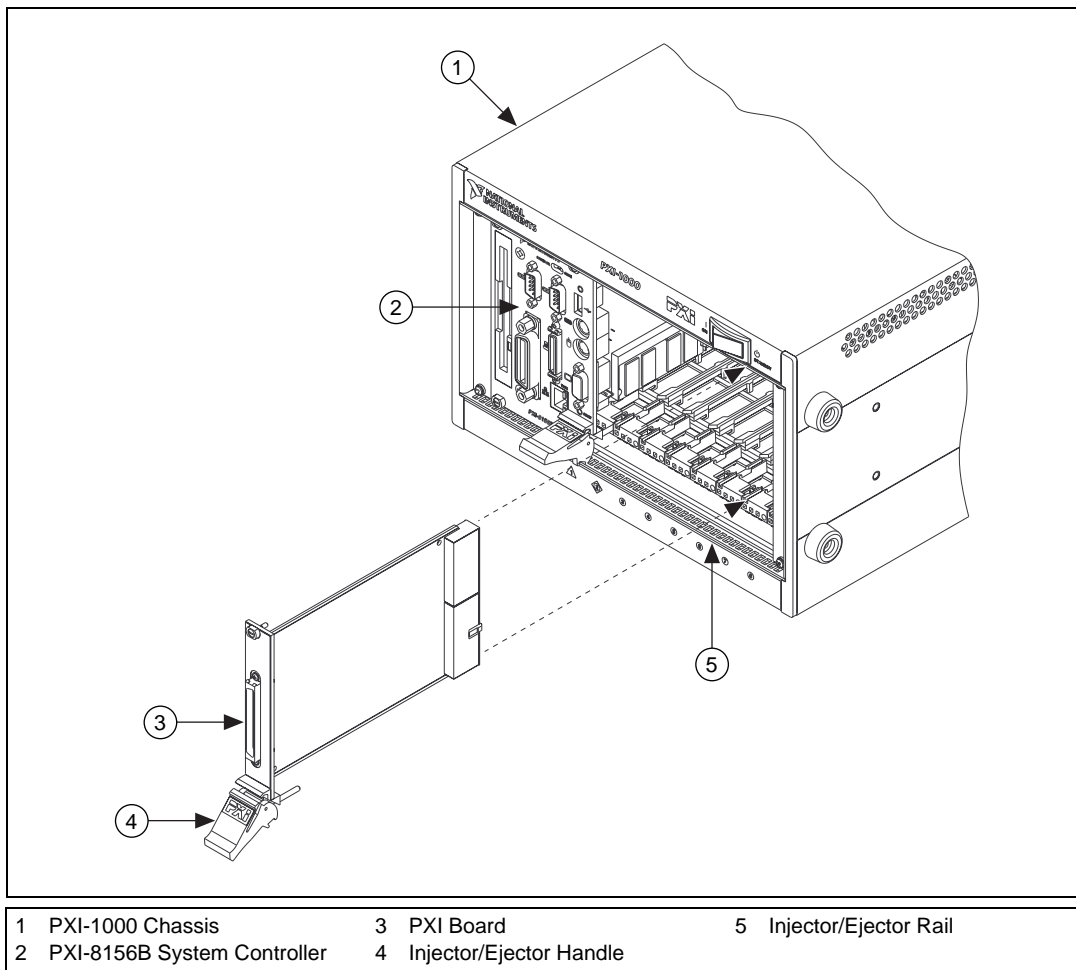

**Figure 3-12.** PXI-8156B Installed in a PXI Mainframe

## **How to Remove the Unit from the PXI Mainframe**

The PXI-8150B Series is designed for easy handling. If you later decide to change any of the jumper settings or the amount of DRAM installed on the module, remove the unit from the PXI mainframe as follows:

1. Remove the bracket-retaining screws in the front panel.
2. Press the injector/ejector handle down.
3. Slide the unit out of the mainframe.

---

# BIOS

This chapter contains information on BIOS, the low-level interface between the hardware and PC software that configures and tests your hardware when you start up the system. This BIOS (Basic Input Output System) is an easy-to-use graphical user interface so you can configure system aspects according to your needs.

## Entering BIOS Setup

---

To enter the BIOS setup program, perform the following steps.

1. Turn on or reboot the system. A screen appears with a series of diagnostic checks.
2. When the message **Press <DEL> to enter SETUP** appears, press the <DEL> key to enter the BIOS setup program.
3. Choose options with the keyboard. Modify the settings to reflect system options.

## Default BIOS Setup Settings

---

To restore the default settings while inside the BIOS setup program, select either **Load Optimal** or **Load Fail-Safe**.

Select the **Optimal** settings if you want to get maximum performance from the PXI-8150B Series. **Fail Safe** settings are more conservative settings.

## Updating the BIOS

---

Your PXI-8150B Controller contains Flash ROM which allows the BIOS to be updated. A floppy disk with two different BIOS files comes with your controller. One file enables the flat panel outputs for use with the PXI-1020 and PXI-1025 chassis. The other file disables the flat panel output. Copy the contents of the floppy disk to a bootable floppy disk, boot from the floppy, and follow the prompts to update the BIOS. Contact National Instruments for other BIOS updates.

---

# Specifications

This appendix lists the electrical, mechanical, and environmental specifications of the PXI-8150B Series embedded computer, and describes how to add RAM.

## Electrical

---

<b>PXI-8155B 233 MHz MMX Processor</b>		
<b>Voltage (V)</b>	<b>Current (A)</b>	
	<b>Typical</b>	<b>Maximum</b>
+3.3	4.5 A	8.5 A
+5	1.65 A	3.8 A
+12	0.05 A	1.0 A
-12	0.01 A	0.1 A

<b>PXI-8155B 333 MHz MMX Processor</b>		
<b>Voltage (V)</b>	<b>Current (A)</b>	
	<b>Typical</b>	<b>Maximum</b>
+3.3	4.0 A	10 A
+5	1.65 A	3.8 A
+12	0.05 A	1.0 A
-12	0.01 A	0.1 A

<b>PXI-8156B 233 MHz MMX Processor</b>		
<b>Voltage (V)</b>	<b>Current (A)</b>	
	<b>Typical</b>	<b>Maximum</b>
+3.3	4.5 A	8.5 A
+5	1.85 A	4.0 A
+12	0.05 A	1.0 A
-12	0.01 A	0.1 A

<b>PXI-8156B 333 MHz MMX Processor</b>		
<b>Voltage (V)</b>	<b>Current (A)</b>	
	<b>Typical</b>	<b>Maximum</b>
+3.3	4.5 A	10 A
+5	1.85 A	4.0 A
+12	0.05 A	1.0 A
-12	0.01 A	0.1 A

## Physical

<b>Characteristic</b>	<b>Specification</b>
Board Dimensions	PXI 3U-size module 8.1 by 13 by 21.6 cm (3.2 by 5.1 by 8.5 in.)
Slot Requirements	One system slot plus three controller expansion slots
Compatibility	Fully compatible with PXI specification
MTBF	Contact National Instruments
Weight	1.1 Kg (2.4 lb) typical

## Environmental

Characteristic	Specification
Temperature	0° to 50° C operating; –20° to 70° C storage
Relative Humidity	10% to 90% noncondensing, operating; 5% to 95% noncondensing, storage
EMI	FCC Class A verified, EC verified
Random Vibration	Operational: 5 to 500 Hz, 0.31 g <sub>RMS</sub> , 3 axes Non-operational: 10 to 500 Hz, 2.46 g <sub>RMS</sub> , 3 axes
Functional Shock	MIL-T-28800E Class 3 (per Section 4.5.5.4.1) Half-sine shock pulse (11 ms duration, 30 g peak, 3 shocks per face). Also meets IEC standard 60068-2-27.



### Note

*Random vibration profiles were developed in accordance with MIL-T-28800E and MIL-STD-810E Method 514. Test levels exceed those recommended in MIL-STD-810E for Category 1 (Basic Transportation, Figures 514.4-1 through 514.4-3). Test report available upon request.*

## Adding RAM

To add RAM to the PXI-8150B Series, remove the unit from the PXI mainframe and add SO-DIMM modules to the empty SO-DIMM sockets. National Instruments recommends the following types of SO-DIMMs for use with the PXI-8150B Series controller (SDRAM):

- 32 MB: 4 MB × 64 SO-DIMMs—10 ns, 1.05 in. max.
- 64 MB: 8 MB × 64 SO-DIMMs—10 ns, 1.05 in. max.
- 128 MB: 16 MB × 64 SO-DIMMs—10 ns, 1.05 in. max.



### Note

*National Instruments has tested and verified that the SO-DIMMs we sell work with the PXI-8150B Series. We recommend you purchase your SO-DIMM modules from National Instruments. Other off-the-shelf SO-DIMM modules are not guaranteed to work properly.*

---

# PXI-8150B Series System Resources

This appendix describes the system resources available on the PXI-8150B Series embedded computer and where they are allocated. Because PCI is a relatively new addition to PCs, this appendix describes how PCI interrupts fit into a PC architecture before listing the devices that use them.

## PCI Interrupts

---

PCI interrupts are more flexible than ISA interrupts because multiple devices can share these interrupts. PCI interrupts do not actually connect to the processor directly; they map through ISA interrupts in the system I/O module. The interrupt handler for a particular ISA interrupt must know if it will be acknowledging a PCI device.

## Resource Tables

---

The following tables describe where system resources are assigned. Table B-1 lists how the ISA interrupts are allocated on the PXI-8150B Series and whether they are driven by a PCI interrupt. Table B-2 lists DMA channel allocation, and Table B-3 gives the I/O address map.

**Table B-1.** PXI-8150B Series ISA Interrupt Resource Allocations

ISA Interrupt	PCI Interrupt	Device
NMI	None	Parity
0	None	Timer
1	None	Keyboard
2	None	IRQ Expansion (8-15)
3	None	COM2
4	None	COM1

**Table B-1.** PXI-8150B Series ISA Interrupt Resource Allocations (Continued)

ISA Interrupt	PCI Interrupt	Device
5	PCI/None	Plug and Play PXI Modules/Watchdog timer if enabled
6	None	Floppy Drive
7	None	LPT1
8	None	RTC
9	None	Ethernet
10	PCI	Plug and Play PXI Modules
11	None	GPIB
12	None	Mouse
13	None	FPERR
14	None	IDE
15	None	IDE

**Table B-2.** PXI-8150B Series DMA Channel Resource Allocations

DMA Channel	Device
0	Free
1	Free
2	Floppy Drive Port
3	Parallel Port (ECP Mode)
4	Free
5	GPIB
6	Free
7	Free



**Table B-3.** PXI-8150B Series I/O Address Map

<b>I/O Address</b>	<b>Device</b>
000–00F	8237 DMA #1
020–021	8259 PIC #1
022–024	SYSCFG
040–043	8253 Timer
060–066	8742 Controller
070–077	CMOS RAM and NMI Mask Register
078–07B	BIOS Timer
080–090	DMA Page Registers
092	Reserved
094–09F	DMA Page Registers
0A0–0A1	8259 PIC #2
0B2–0B3	Advanced Power Management
0C0–0DF	8237 DMA #2 (word mapped)
0F0–0FF	Numeric Processor Error Reg
170–177	Reserved
1F0–1F7	IDE
200–270	Free
278–27F	LPT*
280–2DF	Free
2C0–2DF	GPIB
2E8–2EF	COM*
2F8–2FF	COM*
300–30F	Ethernet
310–31F	Free
320–327	Watchdog
328–36F	Free

**Table B-3.** PXI-8150B Series I/O Address Map (Continued)

<b>I/O Address</b>	<b>Device</b>
370–377	Reserved
378–37F	LPT*
380–3B0	Free
3BC–3BF	LPT*
3E8–3EF	COM*
3F0–3F7	Floppy
3F8–3FF	COM*
40A	Scatter/Gather Int Status Register
40B	DMA1 Extended Mode Registers
410–41F	Scatter/Gather Status
420–43F	Scatter/Gather Descriptor Table Pointer
480–48B	DMA High Page Registers
48C–4D6	Reserved
CF8–CFC	NUM Access
F8D	Reserved
* Relocatable	

**Note**

*I/O locations in italics indicate addresses above 1 KB. These locations are not usually accessible in an ISA-based system; however, newer PCI-based chip sets have increased the amount of I/O space available.*



---

# LED Indicators

This appendix describes how to interpret the status of the PXI-8150B Series computer by reading the LEDs on the front panel.

## Interface Status and Access LEDs

---

### POWER OK

When lit, the **POWER OK** LED indicates that the power is on and the PXI-8150B is out of reset.

### DRIVE LED

The **DRIVE** LED indicates when an access to the internal hard disk drive is occurring.

## Ethernet LEDs (PXI-8156B Only)

---

The Ethernet LEDs (**TX/RX** and **LINK**) indicate the status of the Ethernet interface on the PXI-8156B.

### TX/RX LED

The **TX/RX** LED indicates when the Ethernet interface is receiving or transmitting a packet.

### LINK LED

The **LINK** LED indicates periodic link test passed.

---

# Front Panel and Connectors

This appendix describes the front panel and connectors on the PXI-8150B Series embedded computer.

**Note**

*The illustrations in this appendix show the mating face of the connectors. An asterisk suffix (\*) on a signal name indicates that the signal is active low.*

The PXI-8155B Series has the following front panel connectors:

- VGA Controller
- Extended Capabilities Parallel (ECP)
- PS/2-Style Keyboard
- PS/2-Style Mouse
- Universal Serial Bus (USB)
- RS-232 Serial

The PXI-8156B Series has the following additional front panel connectors:

- Second RS-232 Serial
- IEEE 488.2
- 10BaseT Ethernet

## Front Panel

---

Figure D-1 shows the front panel layout of the PXI-8155B, and Figure D-2 shows the front panel layout of the PXI-8156B. The drawings show dimensions relevant to key elements on the front panel. Dimensions are shown in inches and millimeters, with millimeter dimensions in square brackets. The front panel thickness for all models in the PXI-8150B Series is 2.49 mm (0.098 in.)

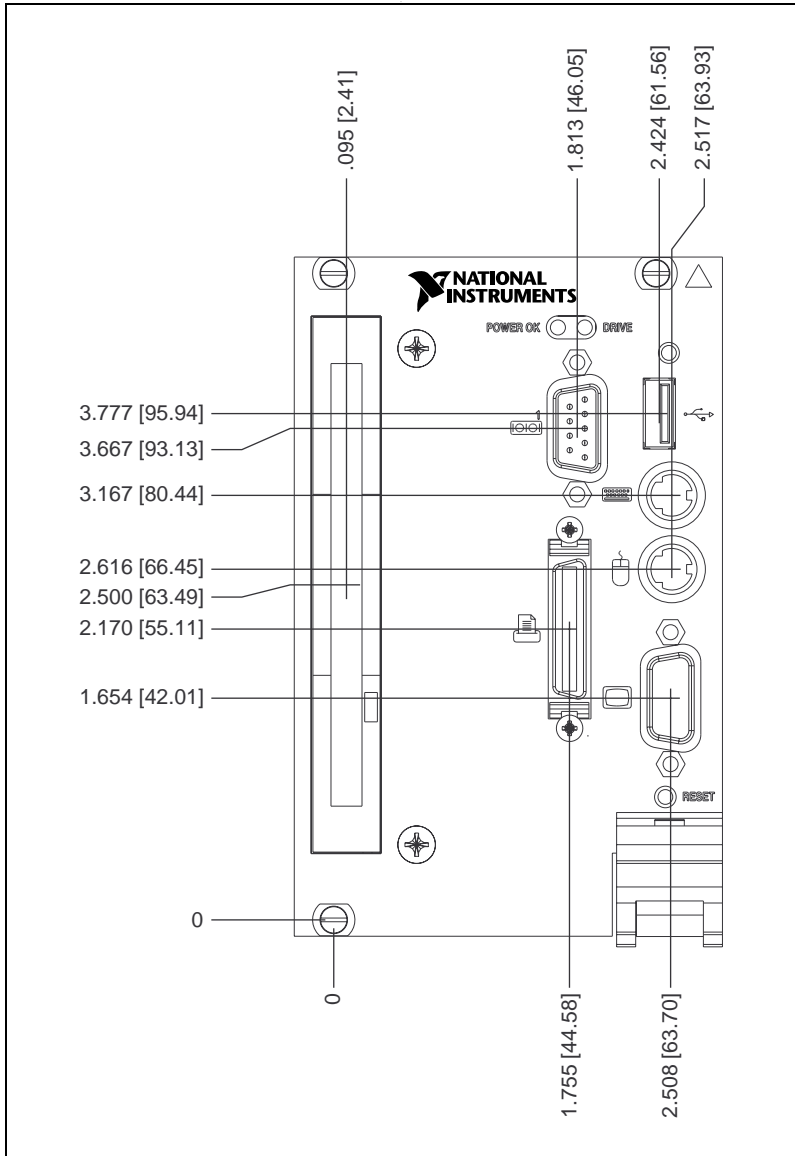

Figure D-1. PXI-8155B Front Panel Layout and Dimensions

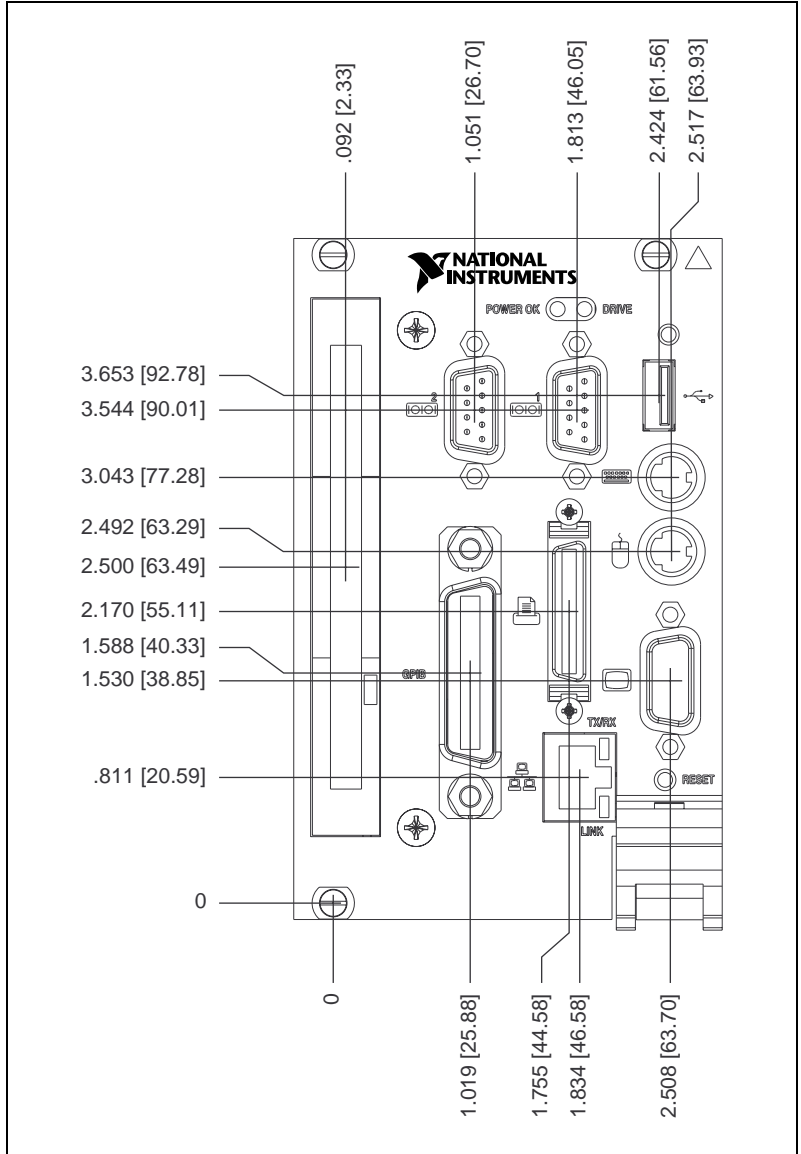
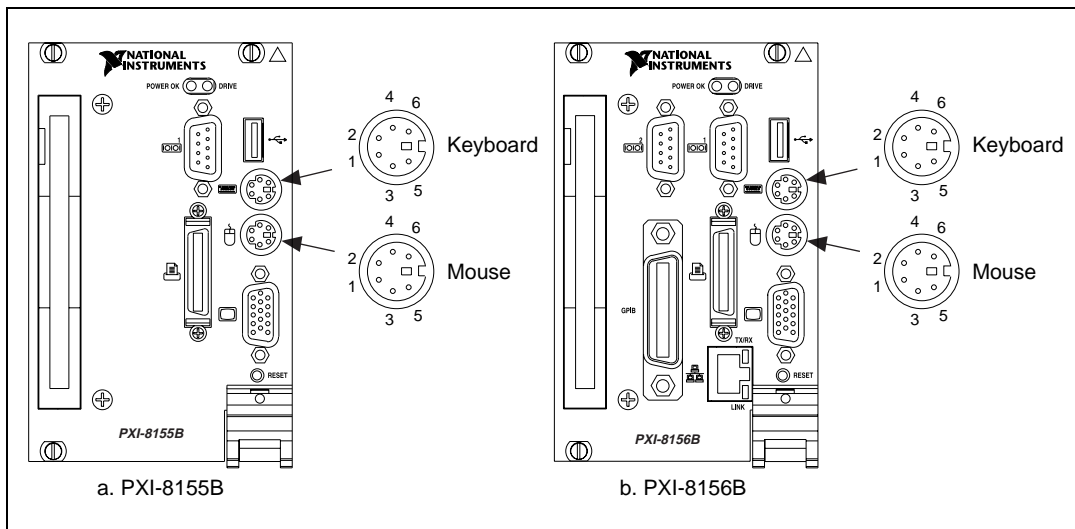

Figure D-2. PXI-8156B Front Panel Layout and Dimensions

# Keyboard and Mouse

Figure D-3 shows the location and pinouts for the keyboard and mouse connectors on the PXI-8150B Series. Table D-1 lists and describes the keyboard and mouse connector signals.

AMP manufactures a mating connector with part numbers 212437-4 (housing), 212435-7 (ferrule), and 66735-4 (pin contact).



**Figure D-3.** Keyboard and Mouse Connectors Location and Pinout

**Table D-1.** Keyboard and Mouse Connector Signals

Pin	Signal Name	Signal Description
1	DATA	Data
2	NC	Not Connected
3	GND	Ground
4	+5V	+5 V
5	CLK	Clock
6	NC	Not Connected

# VGA

Figure D-4 shows the location and pinouts for the VGA connector on the PXI-8150B Series. Table D-2 lists and describes the VGA connector signals.

AMP manufactures a mating connector with part numbers 748364-1 (housing) and 748333-2 (pin contact).

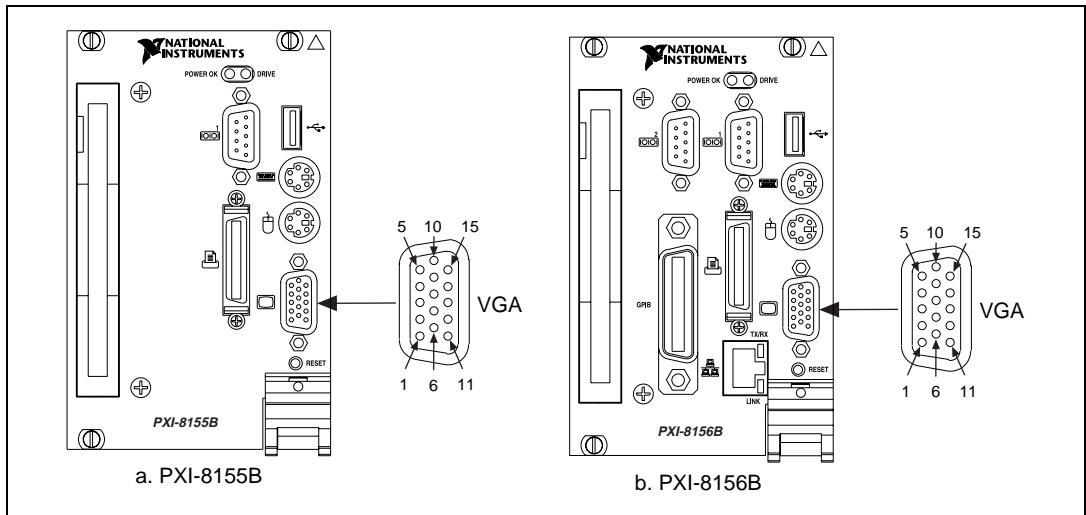

**Figure D-4.** VGA Connector Location and Pinout

**Table D-2.** VGA Connector Signals

Pin	Signal Name	Signal Description
1	R	Red
2	G	Green
3	B	Blue
4	NC	Not Connected
5	GND	Ground
6	GND	Ground
7	GND	Ground
8	GND	Ground



**Table D-2.** VGA Connector Signals (Continued)

Pin	Signal Name	Signal Description
9	NC	Not Connected
10	GND	Ground
11	NC	Not Connected
12	SD	Serial Data
13	HSync	Horizontal Sync
14	VSynC	Vertical Sync
15	SC	Serial Clock

## Ethernet

Figure D-5 shows the location and pinouts for the Ethernet connector on the PXI-8156B. Table D-3 lists and describes the Ethernet connector signals.

AMP manufactures a mating connector, part number 554739-1.

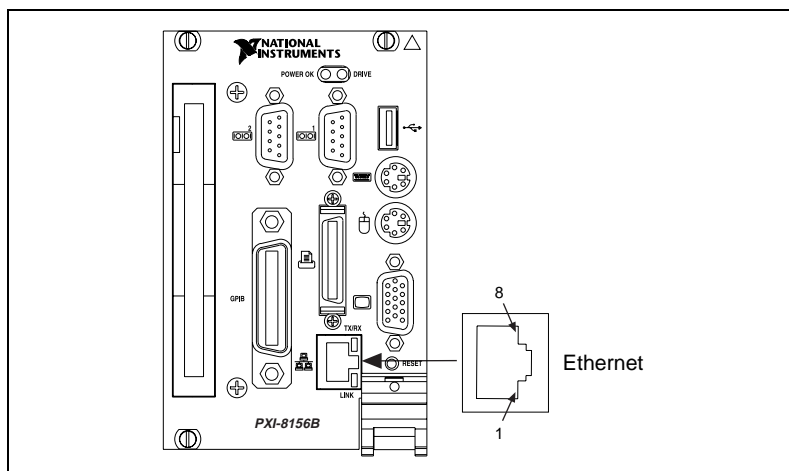

**Figure D-5.** Ethernet Connector Location and Pinout

**Table D-3.** Ethernet Connector Signals

Pin	Signal Description
1	Differential Transmit
2	Differential Transmit
3	Differential Receive
4	NC
5	NC
6	Differential Receive
7	NC
8	NC

## COM1 and COM2

Figure D-6 shows the location and pinouts for the COM1 connector on all models in the PXI-8156B Series and the COM2 connector on the PXI-8156B. Table D-4 lists and describes the COM1 and COM2 connector signals.

AMP manufactures a serial port mating connector, part number 745491-5, for the COM1 and COM2 connectors on the PXI-8156B.

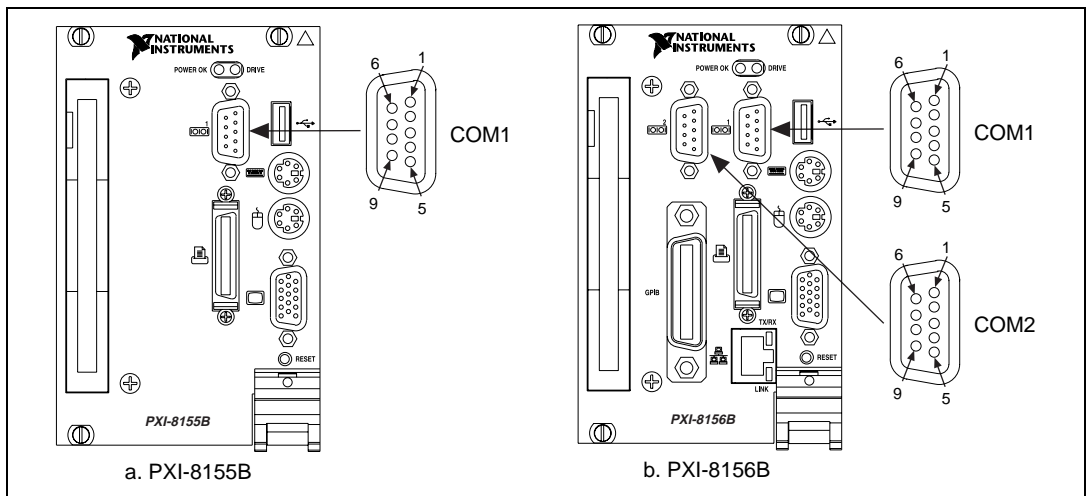
**Figure D-6.** COM1 and COM2 Connectors Location and Pinout

**Table D-4.** COM1 and COM2 Connector Signals

Pin	Signal Name	Signal Description
1	DCD*	Data Carrier Detect
2	RXD*	Receive Data
3	TXD*	Transmit Data
4	DTR*	Data Terminal Ready
5	GND	Ground
6	DSR*	Data Set Ready
7	RTS*	Ready to Send
8	CTS*	Clear to Send
9	RI*	Ring Indicator

## Parallel Port

Figure D-7 shows the location and pinouts for the IEEE-1284 connector on the PXI-8156B. Table D-5 lists and describes the IEEE-1284 connector signals.

AMP manufactures a parallel port compatible connector, part number 2-175677-5.

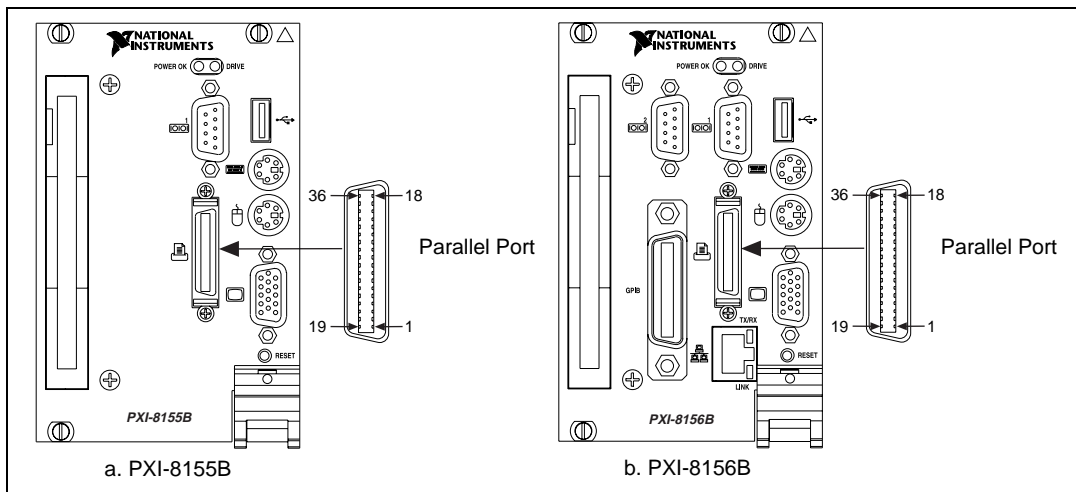

**Figure D-7.** Parallel Port Connector Location and Pinout

**Table D-5.** Parallel Port Connector Signals

Pin	Signal Name	Signal Description
1	BUSY*	Device Busy
2	SLCTIN*	Select Input
3	ACK*	Acknowledge
4	FAULT*	Fault
5	ERROR	Error
6	PD0	Data Bit 0
7	PD1	Data Bit 1
8	PD 2	Data Bit 2
9	PD3	Data Bit 3
10	PD4	Data Bit 4
11	PD5	Data Bit 5
12	PD6	Data Bit 6
13	PD7	Data Bit 7
14	INIT*	Initialize Printer
15	STROBE*	Strobe
16	SLCT	Select
17	AUTOFD	Auto Line Feed
18	+5V	+5 V
19-35	GND	Ground
36	NC	Not Connected

## GPIB (IEEE-488.2)

Figure D-8 shows the location and pinouts for the GPIB connector on the PXI-8156B. Table D-6 lists and describes the GPIB connector signals.

AMP manufactures a GPIB mating connector, part number 554349-01.

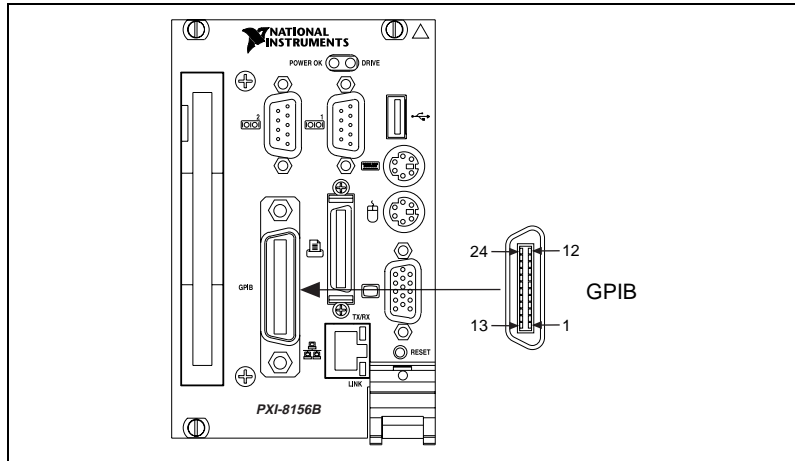

**Figure D-8.** GPIB Connector Location and Pinout

**Table D-6.** GPIB Connector Signals

Pin	Signal Name	Signal Description
1	DIO1*	Data Bit 1
2	DIO2*	Data Bit 2
3	DIO3*	Data Bit 3
4	DIO4*	Data Bit 4
5	EOI*	End or Identify
6	DAV*	Data Valid
7	NRFD*	Not Ready for Data
8	NDAC*	Not Data Accepted
9	IFC*	Interface Clear
10	SRQ*	Service Request
11	ATN*	Attention
12	SHIELD	Chassis ground
13	DIO5*	Data Bit 5
14	DIO6*	Data Bit 6
15	DIO7*	Data Bit 7
16	DIO8*	Data Bit 8

**Table D-6.** GPIB Connector Signals (Continued)

Pin	Signal Name	Signal Description
17	REN*	Remote Enable
18-25	GND	Logic Ground

## Universal Serial Bus

Figure D-9 shows the location and pinouts for the Universal Serial Bus (USB) connector. Table D-7 lists and describes the USB connector signals.

AMP manufactures a USB mating connector, part number 787633.

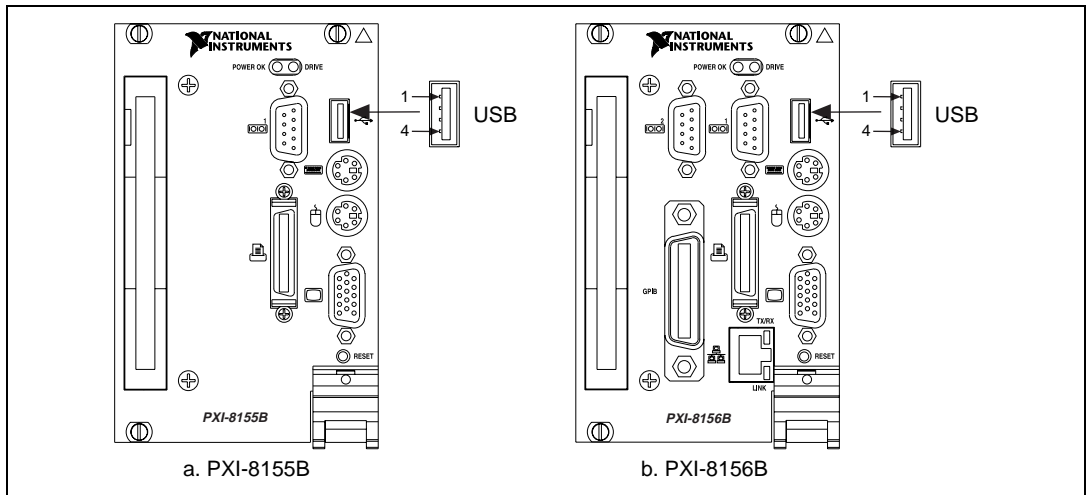
**Figure D-9.** USB Connector Location and Pinout**Table D-7.** USB Connector Signals

Pin	Signal Name	Signal Description
1	VCC	Cable Power (+5 V)
2	-Data	USB Data-
3	+Data	USB Data+
4	GND	Ground

# PXI Connectors

Figure D-10 shows the location and pinouts for the PXI connector on the PXI-8150B Series. Table D-8 shows the P2 connector pinouts for the PXI connector as it applies to the system controller slot (Slot 1). Table D-9 shows the P1 connector pinouts.

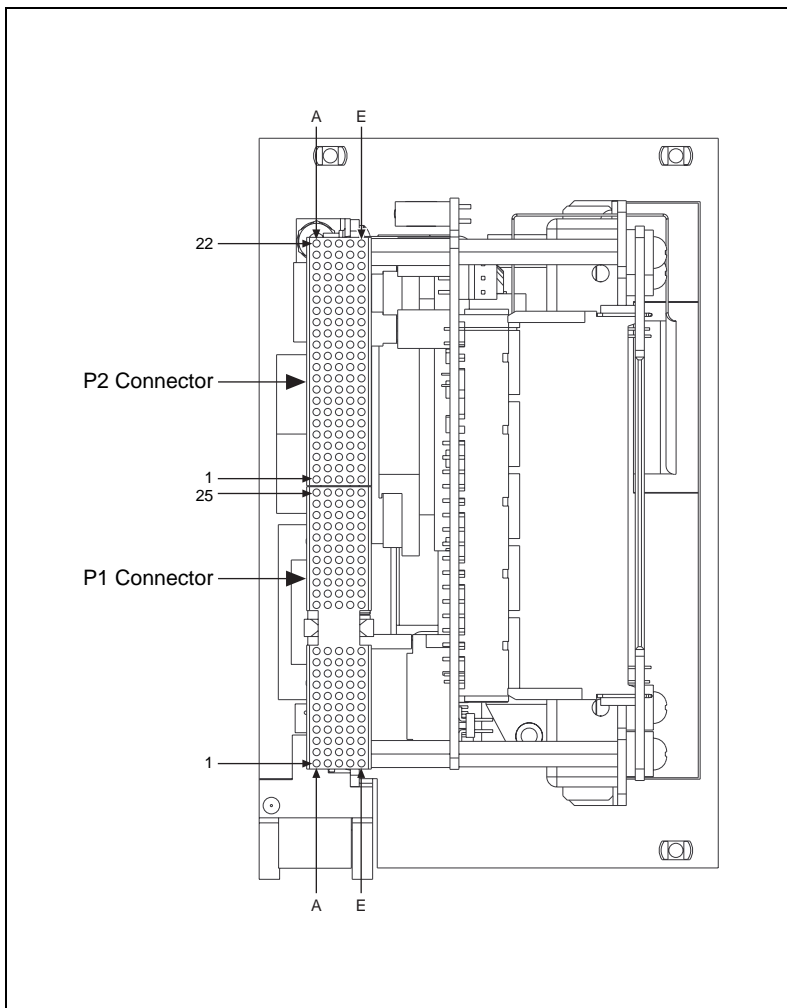

**Figure D-10.** PXI Connectors Location and Pinout

**Table D-8.** P2 Connector Pinouts for the System Controller Slot

Pin	Z	A	B	C	D	E	F
22	GND	<b>PXI_RSVA22</b>	<b>PXI_RSVB22</b>	<b>PXI_RSVC22</b>	<b>PXI_RSVD22</b>	<b>PXI_RSVE22</b>	GND
21	GND	CLK6	GND	RSV	RSV	RSV	GND
20	GND	CLK5	GND	RSV	GND	RSV	GND
19	GND	GND	GND	RSV	RSV	RSV	GND
18	GND	<b>PXI_TRIG3</b>	<b>PXI_TRIG4</b>	<b>PXI_TRIG5</b>	GND	<b>PXI_TRIG6</b>	GND
17	GND	<b>PXI_TRIG2</b>	GND	PRST#	REQ6#	GNT6#	GND
16	GND	<b>PXI_TRIG1</b>	<b>PXI_TRIG0</b>	DEG#	GND	<b>PXI_TRIG7</b>	GND
15	GND	<b>PXI_BRSVA15</b>	GND	FAL#	REQ5#	GNT5#	GND
14	GND	AD[35]	AD[34]	AD[33]	GND	AD[32]	GND
13	GND	AD[38]	GND	V(I/O)	AD[37]	AD[36]	GND
12	GND	AD[42]	AD[41]	AD[40]	GND	AD[39]	GND
11	GND	AD[45]	GND	V(I/O)	AD[44]	AD[43]	GND
10	GND	AD[49]	AD[48]	AD[47]	GND	AD[46]	GND
9	GND	AD[52]	GND	V(I/O)	AD[51]	AD[50]	GND
8	GND	AD[56]	AD[55]	AD[54]	GND	AD[53]	GND
7	GND	AD[59]	GND	V(I/O)	AD[58]	AD[57]	GND
6	GND	AD[63]	AD[62]	AD[61]	GND	AD[60]	GND
5	GND	C/BE[5]#	GND	V(I/O)	C/BE[4]#	PAR64	GND
4	GND	V(I/O)	<b>PXI_BRSVB4</b>	C/BE[7]#	GND	C/BE[6]#	GND
3	GND	CLK4	GND	GNT3#	REQ4#	GNT4#	GND
2	GND	CLK2	CLK3	SYSEN#	GNT2#	REQ3#	GND
1	GND	CLK1	GND	REQ1#	GNT1#	REQ2#	GND
<b>Note:</b> PXI signals are shown in boldface.							



**Table D-9.** P1 Connector Pinouts for the System Controller Slot

Pin	Z	A	B	C	D	E	F
25	GND	5V	REQ64#	ENUM#	3.3V	5V	GND
24	GND	AD[1]	5V	V(I/O)	AD[0]	ACK64#	GND
23	GND	3.3V	AD[4]	AD[3]	5V	AD[2]	GND
22	GND	AD[7]	GND	3.3V	AD[6]	AD[5]	GND
21	GND	3.3V	AD[9]	AD[8]	M66EN	C/BE[0]#	GND
20	GND	AD[12]	GND	V(I/O)	AD[11]	AD[10]	GND
19	GND	3.3V	AD[15]	AD[14]	GND	AD[13]	GND
18	GND	SERR#	GND	3.3V	PAR	C/BE[1]#	GND
17	GND	3.3V	SDONE	SBO#	GND	PERR#	GND
16	GND	DEVSEL#	GND	V(I/O)	STOP#	LOCK#	GND
15	GND	3.3V	FRAME#	IRDY#	GND	TRDY#	GND
12–14	Key Area						
11	GND	AD[18]	AD[17]	AD[16]	GND	C/BE[2]#	GND
10	GND	AD[21]	GND	3.3V	AD[20]	AD[19]	GND
9	GND	C/BE[3]#	IDSEL	AD[23]	GND	AD[22]	GND
8	GND	AD[26]	GND	V(I/O)	AD[25]	AD[24]	GND
7	GND	AD[30]	AD[29]	AD[28]	GND	AD[27]	GND
6	GND	REQ#	GND	3.3V	CLK	AD[31]AD[31]	GND
5	GND	BRSVP1A5	BRSVP1B5	RST#	GND	GNT#	GND
4	GND	BRSVP1A4	GND	V(I/O)	INTP	INTS	GND
3	GND	INTA#	INTB#	INTC#	5V	INTD#	GND
2	GND	TCK	5V	TMS	TDO	TDI	GND
1	GND	5V	–12V	TRST#	+12V	5V	GND

---

# Common Questions

This appendix answers common questions you may have when using the PXI-8150B Series embedded computer.

## **What do the LEDs on the front of the PXI-8150B mean?**

Refer to Appendix C, *LED Indicators*, for a description of the front panel LEDs.

## **If I boot the computer without video, and then plug in the video, why is it in black and white?**

When the computer first boots, the video chips try to synchronize with the monitor. If the monitor is not there, the video chips cannot synchronize and establish color. You need to have the monitor attached at boot time to get color.

## **What type of video interface is onboard the PXI-8150B? What video drivers are included? Can I use Super VGA? If my application requires a special type of video display, how do I configure my PXI-8150B?**

The PXI-8150B Series uses the S3 Virge/MX Series chip family, a combination graphics accelerator and RAMDAC with TFT LCD support. The chips in this family are compatible with the Standard VGA video output MS Windows video driver, as well as the S3 video driver. For more information on the video driver, refer to the `c:\images\manuals` directory.

## **What kind of monitor can I use with the PXI-8150B?**

PXI-8150B computers that use Super VGA video output work only with monitors having a horizontal scan rate of at least 50 kHz and a vertical scan rate of 60 Hz.



### **Caution**

*Make sure that your monitor meets this specification. Enabling the Super VGA option on a monitor that does not meet this specification will damage your monitor.*

**What if my keyboard connector does not fit into the keyboard port on the PXI-8150B?**

You can plug keyboards that have a 6-pin Mini DIN PS/2 type connector directly into the PXI-8150B. You can use the keyboard adapter cable that is included with your kit to adapt the larger AT keyboard connector to the 6-pin Mini DIN connector.

**How do I add RAM to the PXI-8150B? What is the maximum amount of RAM that I can have installed?**

For information about adding RAM to the PXI-8150B, refer to Appendix A, *Specifications*.

**Which interrupt levels are free for use by PXI bus boards? Which area of upper memory (adapter space) is free for use by PXI bus boards or expanded memory manager software programs?**

See Appendix B, *PXI-8150B Series System Resources*, for information on the available port I/O register space, upper memory area, interrupts, and DMA channels.

**How do I check the configuration of the memory, floppy drive, hard drive, time/date, and so on?**

You can view these parameters in the BIOS setup. To enter the BIOS setup, reboot the PXI-8150B and press the <DEL> key during the memory tests. Refer to Chapter 4, *BIOS*, for more information.

**How can I boot from an external SCSI hard drive?**

1. Enter the BIOS setup program as described in Chapter 4, *BIOS*.
2. Select **BIOS Features**.
3. Change **Boot Sequence Setup** so that SCSI is listed first.
4. Use the <Esc> key to exit from this screen.
5. Select **Save and Exit Setup**.

**Can I use the internal IDE drive and an external SCSI hard drive at the same time?**

Yes.

**My CMOS is corrupted. How do I set it back to default?**

1. Enter the BIOS setup program as described in Chapter 4, *BIOS*.
2. Select **Load Optimal**.
3. Answer **Y** (Yes) to the verification prompt.
4. Select **Save and Exit Setup**.

---

# Customer Communication

For your convenience, this appendix contains forms to help you gather the information necessary to help us solve your technical problems and a form you can use to comment on the product documentation. When you contact us, we need the information on the Technical Support Form and the configuration form, if your manual contains one, about your system configuration to answer your questions as quickly as possible.

National Instruments has technical assistance through electronic, fax, and telephone systems to quickly provide the information you need. Our electronic services include a bulletin board service, an FTP site, a fax-on-demand system, and e-mail support. If you have a hardware or software problem, first try the electronic support systems. If the information available on these systems does not answer your questions, we offer fax and telephone support through our technical support centers, which are staffed by applications engineers.

## Electronic Services

### Bulletin Board Support

National Instruments has BBS and FTP sites dedicated for 24-hour support with a collection of files and documents to answer most common customer questions. From these sites, you can also download the latest instrument drivers, updates, and example programs. For recorded instructions on how to use the bulletin board and FTP services and for BBS automated information, call 512 795 6990. You can access these services at:

United States: 512 794 5422

Up to 14,400 baud, 8 data bits, 1 stop bit, no parity

United Kingdom: 01635 551422

Up to 9,600 baud, 8 data bits, 1 stop bit, no parity

France: 01 48 65 15 59

Up to 9,600 baud, 8 data bits, 1 stop bit, no parity

### FTP Support

To access our FTP site, log on to our Internet host, `ftp.natinst.com`, as anonymous and use your Internet address, such as `joesmith@anywhere.com`, as your password. The support files and documents are located in the `/support` directories.

## Fax-on-Demand Support

Fax-on-Demand is a 24-hour information retrieval system containing a library of documents on a wide range of technical information. You can access Fax-on-Demand from a touch-tone telephone at 512 418 1111.

## E-Mail Support (Currently USA Only)

You can submit technical support questions to the applications engineering team through e-mail at the Internet address listed below. Remember to include your name, address, and phone number so we can contact you with solutions and suggestions.

support@natinst.com

## Telephone and Fax Support

National Instruments has branch offices all over the world. Use the list below to find the technical support number for your country. If there is no National Instruments office in your country, contact the source from which you purchased your software to obtain support.

<b>Country</b>	<b>Telephone</b>	<b>Fax</b>
Australia	03 9879 5166	03 9879 6277
Austria	0662 45 79 90 0	0662 45 79 90 19
Belgium	02 757 00 20	02 757 03 11
Brazil	011 284 5011	011 288 8528
Canada (Ontario)	905 694 0085	905 785 0086
Canada (Québec)	514 694 8521	514 694 4399
Denmark	45 76 26 00	45 76 26 02
Finland	09 725 725 11	09 725 725 55
France	0 1 48 14 24 24	0 1 48 14 24 14
Germany	089 741 31 30	089 714 60 35
Hong Kong	2645 3186	2686 8505
India	91805275406	91805275410
Israel	03 6120092	03 6120095
Italy	02 413091	02 4139215
Japan	03 5472 2970	03 5472 2977
Korea	02 596 7456	02 596 7455
Mexico (D.F.)	5 280 7625	5 520 3282
Mexico (Monterrey)	8 357 7695	8 365 8543
Netherlands	0348 433466	0348 430673
Norway	32 84 84 00	32 84 86 00
Singapore	2265886	2265887
Spain (Madrid)	91 640 0085	91 640 0533
Spain (Barcelona)	93 582 0251	93 582 4370
Sweden	08 587 895 00	08 730 43 70
Switzerland	056 200 51 51	056 200 51 55
Taiwan	02 2377 1200	02 2737 4644
United Kingdom	01635 523545	01635 523154
United States	512 795 8248	512 794 5678

# Technical Support Form

Photocopy this form and update it each time you make changes to your software or hardware, and use the completed copy of this form as a reference for your current configuration. Completing this form accurately before contacting National Instruments for technical support helps our applications engineers answer your questions more efficiently.

If you are using any National Instruments hardware or software products related to this problem, include the configuration forms from their user manuals. Include additional pages if necessary.

Name \_\_\_\_\_

Company \_\_\_\_\_

Address \_\_\_\_\_

\_\_\_\_\_

Fax ( \_\_\_\_ ) \_\_\_\_\_ Phone ( \_\_\_\_ ) \_\_\_\_\_

Computer brand \_\_\_\_\_ Model \_\_\_\_\_ Processor \_\_\_\_\_

Operating system (include version number) \_\_\_\_\_

Clock speed \_\_\_\_\_ MHz RAM \_\_\_\_\_ MB Display adapter \_\_\_\_\_

Mouse \_\_\_yes \_\_\_no Other adapters installed \_\_\_\_\_

Hard disk capacity \_\_\_\_\_ MB Brand \_\_\_\_\_

Instruments used \_\_\_\_\_

\_\_\_\_\_

National Instruments hardware product model \_\_\_\_\_ Revision \_\_\_\_\_

Configuration \_\_\_\_\_

National Instruments software product \_\_\_\_\_ Version \_\_\_\_\_

Configuration \_\_\_\_\_

The problem is: \_\_\_\_\_

\_\_\_\_\_

\_\_\_\_\_

\_\_\_\_\_

\_\_\_\_\_

List any error messages: \_\_\_\_\_

\_\_\_\_\_

\_\_\_\_\_

The following steps reproduce the problem: \_\_\_\_\_

\_\_\_\_\_

\_\_\_\_\_

\_\_\_\_\_

\_\_\_\_\_

# PXI-8150B Series Hardware and Software Configuration Form

Record the settings and revisions of your hardware and software on the line to the right of each item. Complete a new copy of this form each time you revise your software or hardware configuration, and use this form as a reference for your current configuration. Completing this form accurately before contacting National Instruments for technical support helps our applications engineers answer your questions more efficiently.

## National Instruments Products

PXI-8150B Series Model Number \_\_\_\_\_

PXI-8150B Series Part Number \_\_\_\_\_

PXI-8150B Series Serial Number \_\_\_\_\_

DRAM SO-DIMMs Installed \_\_\_\_\_

Hard Drive Size \_\_\_\_\_

W1 (CPU Board): CMOS \_\_\_\_\_

W2 (CPU Board): INTP Connection \_\_\_\_\_

W3 (CPU Board): INTS Connection \_\_\_\_\_

W14 (CPU Board): Onboard Video \_\_\_\_\_

W17 (CPU Board): LCD Resolution \_\_\_\_\_

S1 (CPU Board): Active Keyboard Port \_\_\_\_\_

S2 (CPU Board): Active Mouse Port \_\_\_\_\_

W1 (I/O Board): Ethernet EEPROM (PXI-8156B only) \_\_\_\_\_

W3, W4 (I/O Board): LCD Display Output on Boot \_\_\_\_\_

List National Instruments Software Installed and Version

NI-VISA Version \_\_\_\_\_

NI-488.2 Version \_\_\_\_\_

NI-DAQ Version \_\_\_\_\_

LabVIEW Version \_\_\_\_\_

LabWindows/CVI Version \_\_\_\_\_

Other National Instruments Software Version \_\_\_\_\_

Programming Choice \_\_\_\_\_



## Other Products

Operating System Version \_\_\_\_\_

Operating System Mode \_\_\_\_\_

Programming Language \_\_\_\_\_

Programming Language Version \_\_\_\_\_

PXI Mainframe Manufacturer and Model \_\_\_\_\_

List Other Boards in PXI Mainframe

PXI Slot	Manufacturer, Description, and Function
2	
3	
4	
5	
6	
7	
8	

# Documentation Comment Form

National Instruments encourages you to comment on the documentation supplied with our products. This information helps us provide quality products to meet your needs.

**Title:** *PXI-8150B Series User Manual*

**Edition Date:** February 1999

**Part Number:** 322321A-01

Please comment on the completeness, clarity, and organization of the manual.

---

---

---

---

---

---

---

---

If you find errors in the manual, please record the page numbers and describe the errors.

---

---

---

---

---

---

---

---

Thank you for your help.

Name \_\_\_\_\_

Title \_\_\_\_\_

Company \_\_\_\_\_

Address \_\_\_\_\_

\_\_\_\_\_

Phone ( \_\_\_\_ ) \_\_\_\_\_ Fax ( \_\_\_\_ ) \_\_\_\_\_

**Mail to:** Technical Publications  
National Instruments Corporation  
6504 Bridge Point Parkway  
Austin, TX 78730-5039

**Fax to:** Technical Publications  
National Instruments Corporation  
(512) 794-5678

# Glossary

---

Prefix	Meanings	Value
n-	nano-	$10^{-9}$
$\mu$ -	micro-	$10^{-6}$
m-	milli-	$10^{-3}$
c-	centi-	$10^{-2}$
K-	kilo-	$10^3$
M-	mega-	$10^6$
G-	giga-	$10^9$

## Symbols

° degrees

$\Omega$  ohms

% percent

## A

A amperes

AC Alternating Current

ASIC application-specific integrated circuit

## B

B bytes

backplane An assembly, typically a printed circuit board, with connectors and signal paths that bus the connector pins.

**BIOS** Basic Input/Output System. BIOS functions are the fundamental level of any PC or compatible computer. BIOS functions embody the basic operations needed for successful use of the computer's hardware resources.

## **C**

**C** Celsius

**cache** Small portion of high-speed memory used for temporary storage of frequently used data

**CMOS** Complementary Metal Oxide Semiconductor; a process used in making chips

**CompactPCI** An adaptation of the PCI specification for industrial and/or embedded applications that require a more robust mechanical form factor than desktop PCI. CompactPCI provides a standard form factor for those applications requiring the high performance of PCI as well as the small size and ruggedness of a rack-mount system.

## **D**

**DC** Direct Current

**DIMM** Dual In-line Memory Module

**DMA** Direct Memory Access; a method by which data is transferred between devices and internal memory without intervention of the central processing unit

**DRAM** Dynamic RAM (Random Access Memory); storage that the computer must refresh at frequent intervals

## **E**

**ECP** Extended Capabilities Parallel

**EDO** Extended Data Out

**EEPROM** Electronically Erasable Programmable Read Only Memory

embedded controller	An intelligent CPU (controller) interface plugged directly into the PXI backplane, giving it direct access to the PXI bus. It must have all of its required PXI interface capabilities built in.
EMC	Electromagnetic Compatibility
EMI	electromagnetic interference
EPP	Enhanced Parallel Port
expansion ROM	An onboard EEPROM that may contain device-specific initialization and system boot functionality

**F**

FCC	Federal Communications Commission
-----	-----------------------------------

**G**

g	<ol style="list-style-type: none"> <li>1. grams</li> <li>2. A measure of acceleration equal to 9.8 m/s<sup>2</sup>.</li> </ol>
GPIB	General Purpose Interface Bus (IEEE 488)
$g_{RMS}$	A measure of random vibration. The root mean square of acceleration levels in a random vibration test profile.

**H**

Hz	hertz; cycles per second
----	--------------------------

**I**

IDE	Integrated Drive Electronics; hard disk and built-in controller
IEEE	Institute of Electrical and Electronics Engineers
in.	inches

instrument driver      A set of routines designed to control a specific instrument or family of instruments, and any necessary related files for LabWindows/CVI or LabVIEW

interrupt      A means for a device to request service from another device

interrupt level      The relative priority at which a device can interrupt

I/O      input/output; the techniques, media, and devices used to achieve communication between machines and users

IRQ\*      Interrupt signal

ISA      Industry Standard Architecture; the original PC bus architecture, specifically the 16-bit AT bus

## **K**

KB      kilobytes of memory

## **L**

LAN      Local Area Network; communications network that serves users within a confined geographical area. It is made up of servers, workstations, a network operating system, and a communications link.

LED      light-emitting diode

## **M**

m      meters

master      A functional part of a PXI device that initiates data transfers on the PXI backplane. A transfer can be either a read or a write.

MB      megabytes of memory

MTBF      Mean time between failure

MTTR      Mean time to repair

**N**

NI-488 or NI-488.2	The National Instruments software for GPIB systems
NI-DAQ	The National Instruments software for data acquisition instruments
NI-VISA	The National Instruments implementation of the VISA standard; an interface-independent software that provides a unified programming interface for VXI, GPIB, and serial instruments
NMI	Non-maskable interrupt; high-priority interrupt that cannot be disabled by another interrupt. It is used to report malfunctions such as parity, bus and math coprocessor errors.

**P**

PCI	Peripheral Component Interconnect. The PCI bus is a high-performance 32-bit or 64-bit bus with multiplexed address and data lines.
PCMCIA	Personal Computer Memory Card International Association
peripheral	any hardware device connected to a computer, such as a monitor, keyboard, printer, plotter, disk or tape drive, graphics tablet, scanner, mouse, and so on
POSC	Power On Self Configuration
PXI	PCI eXtensions for Instrumentation; an open implementation of CompactPCI that adds electrical features that meet the high-performance requirements of instrumentation applications by providing triggering, local buses, and system clock capabilities. PXI also offers two-way interoperability with CompactPCI products.

**R**

RAM	Random Access Memory; the computer's primary workspace
RAMDAC	Random Access Memory Digital to Analog Converter; the VGA controller chip that maintains the color palette and converts data from memory into analog signals for the monitor
resource	hardware settings used by devices in a computer system, including ISA interrupt level, DMA channel, and I/O address

RMS	Root mean squared. See <i>gRMS</i> .
RTC	Real Time Clock; an electronic circuit that maintains the time of day, and can also provide timing signals for timesharing operations

## S

s	seconds
slave	A functional part of a PXI device that detects data transfer cycles initiated by a PXI bus master and responds to the transfers when the address specifies one of the device's registers
SO-DIMM	Small Outline Dual In-line Memory Module
SRAM	Static RAM; a memory chip that requires power to hold its content. It does not require refresh circuitry as a dynamic RAM chip, but it does take up more space and uses more power.
ST	Start Trigger
Star Trigger Slot	This slot is located at Slot 2 in a PXI mainframe and has a dedicated trigger line between each peripheral slot. This slot would be used for a module with ST functionality that can provide individual triggers to all other peripherals.

## U

USB	Universal Serial Bus
-----	----------------------

## V

V	Volts
VGA	Video Graphics Array; the minimum video display standard for all PCs

## W

W	Watts
---	-------



# Index

---

## A

Acrobat (online) documentation, *xi*  
active keyboard port (figure), 3-6  
active mouse port (figure), 3-6  
adding RAM, A-3  
address map, I/O (table), B-3 to B-4  
Adobe Acrobat, *xi*

## B

BIOS, 4-1  
    *See also* CMOS.  
    checking settings, E-2  
    default settings, 4-1  
    entering setup, 4-1  
    logic block, 2-3  
    updating, 4-1  
bulletin board support, F-1

## C

chassis support, 1-7  
chip set block, 2-2  
CMOS, E-2  
    *See also* BIOS.  
    configuration, 3-4  
    default jumper and switch settings  
    (table), 3-1  
    setting back to default, E-3  
    switch settings (figure), 3-4  
COM1 and COM2, D-7  
    connector signals (table), D-8  
    connectors location and pinout (figure), D-7  
common questions and answers, E-1 to E-3  
CompactPCI specification, 1-3

configuration, 3-1 to 3-8  
    *See also* installation.  
    checking BIOS settings, E-2  
    CMOS, 3-4  
    common questions, E-1 to E-3  
    CPU board parts locator diagram, 3-3  
    default settings, 3-1 to 3-3  
    electrostatic discharge damage  
    (caution), 3-1  
    Ethernet power-on defaults, 3-5  
    installed system RAM, 3-4  
    keyboard and mouse, 3-6  
    LCD output with PXI-1020 chassis, 3-5  
    LCD resolution, 3-6  
    onboard video, 3-8  
    parts locator diagram, 3-3  
    serial IRQ, INTP, and INTS, 3-7

connectors  
    COM1 and COM2 connector and signals,  
    D-7 to D-8  
    Ethernet connector and signals, D-6 to D-7  
    GPIB connector and signals, D-9 to D-11  
    keyboard and mouse connector and signals,  
    D-4  
    overview, 1-5  
    parallel port connector and signals, D-9  
    peripheral expansion overview (table), 1-6  
    PXI connectors  
        location and pinout (figure), D-12  
        P1 connector pinouts (table), D-14  
        P2 connector pinouts (table), D-13  
    Universal Serial Bus (USB) connector and  
    signals (table), D-11  
    VGA connector and signals, D-5 to D-6  
CPU  
    parts locator diagram, 3-3  
    processor choices, 1-4

custom application-specific interface chips, 1-5  
 customer communication, *xii*, F-1 to F-3  
     bulletin board support, F-1  
     configuration form, F-5  
     documentation comment form, F-7  
     e-mail support, F-2  
     Fax-on-Demand support, F-2  
     FTP support, F-1  
     technical support form, F-3  
     telephone and fax support, F-2

## D

default settings, hardware (table), 3-1  
 DMA channel resource allocation (table), B-2  
 documentation  
     Adobe Acrobat, *xi*  
     conventions used in this manual, *x*  
     how to use this documentation set, *xi*  
     organization of this manual, *ix*  
     related documentation, *xi*  
 documentation comment form, F-7  
 DRIVE LED, 1-5, C-1

## E

ECP (extended capabilities parallel), D-1  
 electrical specifications, A-1 to A-2  
 electronic support services, F-1 to F-2  
 electrostatic discharge damage (caution), 3-1  
 e-mail support, F-2  
 environmental specifications, A-3  
 equipment, optional  
     enhanced parallel port adapter cable, 1-7  
     single-shielded 2m GPIB cable, 1-7  
 Ethernet, D-6 to D-7  
     connector  
         connector location and pinout (figure), D-6  
         connector signals (table), D-7

        connector, bus interface, and function (table), 1-6  
     default jumper and switch settings (table), 3-2  
     external Ethernet-based LAN, connector for, 2-3  
     LEDs (PXI-8156B Series Only)  
         LINK LED, C-1  
         TX/RX LED, C-1  
     logic block, 2-3  
     port status (PXI-8156B Series only), 1-5  
     power-on defaults, 3-5  
 extended capabilities parallel (ECP), D-1

## F

fax and telephone support, F-2  
 Fax-on-Demand support, F-2  
 front panel, D-1 to D-3  
     *See also* connectors.  
     features, 1-5  
     layout and dimensions (figure), D-2 to D-3  
     list of connectors, D-1  
     thickness of, D-1  
 FTP support, F-1  
 functional overview of PXI-8150B Series, 2-1

## G

GPIB (IEEE-488.2), D-9  
     bus, connector, and function (table), 1-6  
     connector location and pinout (figure), D-10  
     connector signals (table), D-10  
     logic block, 2-3  
 GPIB, controlling  
     NI-488.2M software kit, 1-7  
     TNT4882C custom ASIC, 1-5

**H**

hardware and software configuration form, F-5  
 hardware default settings (table), 3-1  
 hardware description, 1-3

**I**

I/O address map (table), B-3 to B-4  
 IDE controller  
   overview (table), 1-6  
   using SCSI hard drive in addition, E-2  
 IDE logic block, 2-3  
 IEEE-488.2, D-1, D-9  
 installation, 3-8 to 3-11  
   *See also* configuration.  
   electrostatic discharge damage (caution), 3-1  
   injector/ejector handle position (caution), 3-8  
   procedure, 3-8 to 3-9  
   PXI-8156B installed in a PXI mainframe (figure), 3-10  
   removing unit from PXI mainframe, 3-11  
 installed system RAM, 3-4  
 interface chips, custom application-specific, 1-5  
 interface status and access LEDs, C-1  
 INTP configuration (figure), 3-7  
 introduction, 1-1  
 INTS configuration (figure), 3-7  
 ISA  
   addresses above 1 KB, B-4  
   interrupt resource allocation (table), B-1 to B-2

**J**

jumpers and switches  
   CMOS operation (figure), 3-4  
   default settings (table), 3-1  
   Ethernet power-on defaults, 3-5  
   keyboard and mouse, 3-6  
   LCD output (PXI-1020 chassis), 3-5  
   LCD resolution, 3-6  
   parts locator diagram, 3-3  
   serial IRQ, INTP, and INTS, 3-7

**K**

keyboard, D-1  
   adapter cable, E-2  
   if connector doesn't fit, E-2  
 keyboard and mouse, D-4  
   configuring, 3-6  
   connector location and pinout (figure), D-4  
   connector signals (table), D-4  
   logic block, 2-3  
   overview (table), 1-6  
 keyboard port (figure), 3-6

**L**

L2 Cache/Tag logic block, 2-2  
 LabVIEW and LabWindows/CVI application software, 1-8  
 LCD output  
   settings (figure), 3-5  
   with PXI-1020 chassis, 3-5  
 LCD resolution, 3-6  
 LEDs  
   Ethernet LEDs, C-1  
   front panel LEDs, 1-5  
   interface status and access LEDs, C-1  
   interpreting status of, C-1  
 LINK LED, 1-5, C-1

**M**

master/slave capabilities, 1-4  
 mating connector, D-4, D-5, D-6, D-7, D-9, D-11  
 memory, 1-4  
     *See also* RAM.  
 monitor, E-1  
     *See also* video.  
 mouse, D-1  
     *See also* keyboard and mouse.  
 mouse port (figure), 3-6

**N**

National Instruments software, 1-7  
 NI-488.2M software kit, 1-7  
 NI-DAQ function library, 1-8  
 NI-VISA high-level programming API, 1-8

**O**

onboard video, 3-8  
 optional equipment  
     enhanced parallel port adapter cable, 1-7  
     single-shielded 2m GPIB cable, 1-7  
 overview of PXI-8150B Series, 1-1

**P**

P1 connector pinouts (table), D-14  
 P2 connector pinouts (table), D-13  
 parallel port, 1-6  
     connector location and pinout (figure), D-8  
     connector signals (table), D-9  
     overview (table), 1-6  
 PC peripherals logic blocks, 2-3  
 PCI bus  
     basis of PXI-8150 Series, 1-2  
     interrupts, B-1

    standard for desktop computer designs, 1-3  
 PCI video circuitry logic block, 2-3  
 peripheral expansion overview (table), 1-6  
 peripherals  
     *See also* connectors.  
     expansion capabilities (table), 1-6  
     installing and configuring, 1-6  
 physical specifications, A-2  
 POWER OK LED, 1-5, C-1  
 PS/2-style keyboard, D-1  
 PS/2-style mouse, D-1  
 PXI connectors, D-12  
     function (logic block), 2-3  
     location and pinout (figure), D-12  
 P1 connector pinouts for the system controller slot (table), D-14  
 P2 connector pinouts for the system controller slot (table), D-13  
 PXI-1020 and PXI-1025 chassis support, 1-7  
 PXI-8150B Series  
     benefits of PXI, 1-3  
     block diagram, 2-2  
     common questions and answers, E-1 to E-3  
     configuration form, F-5  
     configuring, 3-4  
     connecting on the PXI backplane, 3-7  
     controllers, 1-2  
     CPU parts locator diagram, 3-3  
     custom application-specific interface chips, 1-5  
     default settings, hardware (table), 3-1  
     design, 1-3  
     DMA channel resource allocation (table), B-2  
     front panel  
         connectors, D-1  
         features, 1-5  
         thickness of, D-1  
     functional description, 2-1

- hardware and software configuration form, F-5
- hardware default settings (table), 3-1
- I/O address map (table), B-3 to B-4
- I/O board parts locator diagram, 3-3
- installing, 3-8
- ISA interrupt resource allocation (table), B-1
- logic blocks, 2-2 to 2-3
- memory, 1-4
- models, 1-4
- monitor, E-1
- National Instruments software, 1-7
- optional equipment, 1-7
- overview, 1-1
- peripheral expansion overview (table), 1-6
- RAM, recommendations for adding, A-3
- removing from the PXI mainframe, 3-11
- serial IRQ, INTP, and INTS, 3-7
- software, 1-7
- system resources, B-1
- system slot functionality, 1-4
- video interface onboard, E-1

**PXI-8155B**

- embedded computer (figure), 1-1
- front panel layout and dimensions (figure), D-2

**PXI-8156B**

- embedded computer (figure), 1-2
- Ethernet capability, 1-2
- Ethernet port status, 1-5
- front panel layout and dimensions, D-3
- IEEE 488.2 interface, 1-2
- installed in a PXI mainframe (figure), 3-10

## Q

questions and answers, E-1 to E-3

## R

### RAM

- resources. *See* system resources.
- See also* memory.
- adding RAM, A-3
- common questions, E-2
- installed system RAM, 3-4
- SO-DIMMs from National Instruments (note), A-3
- type of memory in PXI-8150B Series, 1-4
- removing unit from PXI mainframe, 3-11
- resource tables, B-1
- RS-232 serial, D-1

## S

- SCSI drive, booting from, E-2
- serial IRQ, INTP, and INTS, 3-7
- serial ports, 1-6
- See also* COM1 and COM2 connectors.
- serial RS-232, D-1
- socket 7 CPU, 2-2
- SO-DIMM logic block, 2-2
- SO-DIMMs from National Instruments (note), A-3
- software, 1-7
  - National Instruments software, 1-7
  - NI-488.2M software kit, 1-7
  - NI-DAQ, 1-8
  - NI-VISA, 1-8
- specifications, A-1 to A-3
  - adding RAM, A-3
  - electrical, A-1
  - environmental, A-3
  - physical, A-2
- switches. *See* jumpers and switches.
- system CMOS. *See* CMOS.

system resources, B-1 to B-4  
    DMA channel resource allocation  
        (table), B-2  
    I/O address map (table), B-3 to B-4  
    ISA interrupt resource allocation (table),  
        B-1 to B-2  
    PCI bus interrupts, B-1  
system slot functionality, 1-4

## T

technical support form, F-3  
telephone and fax support, F-2  
TNT4882C custom ASIC, 1-5  
TX/RX LED, C-1

## U

Universal Serial Bus (USB), 1-6, D-1, D-11  
    connector function, 2-3  
    connector location and pinout (figure),  
        D-11  
    connector signals (table), D-11  
    overview (table), 1-6

## V

VGA, D-5  
    connector signals (table), D-5  
    controller, D-1  
    location and pinout, D-5  
    overview (table), 1-6  
video, 1-6  
    *See also* monitor.  
    *See also* VGA.  
    black and white, E-1  
    interface, E-1  
    monitor (caution), E-1  
    plugging in after booting, E-1  
    type of monitor to use, E-1  
    video interface onboard PXI-8150 Series,  
        E-1

## W

watchdog timer, 1-6  
    logic block, 2-3  
    using and configuring, 2-3