

# GP2Y0A41SK0F

Distance Measuring Sensor Unit  
Measuring distance : 4 to 30 cm  
Analog output type



## ■Description

**GP2Y0A41SK0F** is a distance measuring sensor unit, composed of an integrated combination of PSD (position sensitive detector) , IR-LED (infrared emitting diode) and signal processing circuit. The variety of the reflectivity of the object, the environmental temperature and the operating duration are not influenced easily to the distance detection because of adopting the triangulation method. This device outputs the voltage corresponding to the detection distance. So this sensor can also be used as a proximity sensor.

## ■Agency approvals/Compliance

1. Compliant with RoHS directive (2002/95/EC)

## ■Applications

1. Cleaning robot
2. Personal robot
3. Sanitary

## ■Features

1. Distance measuring sensor is united with PSD, infrared LED and signal processing circuit
2. Short measuring cycle (16.5ms)
3. Distance measuring range : 4 to 30 cm
4. Package size (29.5 × 13.0 × 13.5mm)
5. Analog output type

Notice The content of data sheet is subject to change without prior notice.

In the absence of confirmation by device specification sheets, SHARP takes no responsibility for any defects that may occur in equipment using any SHARP devices shown in catalogs, data books, etc. Contact SHARP in order to obtain the latest device specification sheets before using any SHARP device.

Sheet No.: OP13008EN

■ Schematic

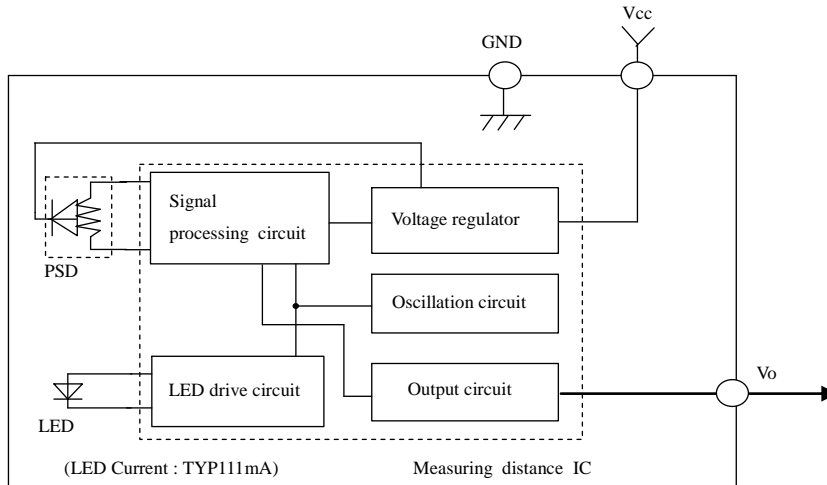

■ Outline

(Stamp)

**Stamp (Example)**  
**SHARP**  
**OA41SK F 5 4**  
 Model name    └─┬─┘  
                   Month (1 to 9, X, Y, Z)  
                   Year (2005:5)

Light emitter    37    Light detector    Lens case  
 29.5    6.3    13  
 $\times 4.5$      $\times 19.7 \pm 0.1$   
 R3.75    R3.75    18.9+0.5  
 $\phi 3.2$  hole     $\phi 3.2$  hole    2  
 3.75    10.1    8.4    7.2    1.2  
                   14.75    7.5    4.15    16.3    (3.3)  
                   2-1.5    13.5

Signal name	Connector
① Vo	J.S.T.TRADING COMPANY,LTD. S3B-PH
② GND	
③ Vcc	

**Materials**  
 Lens: Acrylic acid resin  
 (Visible light cut-off resin)  
 Case: Carbonic ABS  
 (Conductive resin)  
 PCB: Paper phenol

Unit: mm    Scale: 2/1

Name	GP2Y0A41SK0F Outline Dimensions
Drawing No.	CY13044j 02

Note 1: The dimensions marked \* are described the dimensions of lens center position.  
 Note 2: Unspecified tolerance shall be  $\pm 0.3$ mm.  
 Note 3: The dimensions in parenthesis are shown for reference.