

SIMATIC S5

CP 581

Manual

Volume 1/2

Order No. 6ES5 998-2AT21

Release 03

Volume 1 Hardware

Volume 2 Software

Introduction to Application of the
CP 581

1

Installation and Commissioning

2

Reference Section for Hardware

3

Technical Data

4

Abbreviations
Index
List of Tables and Figures

5

Ordering Information

6

7

8

9

10

Copyright

Copyright © Siemens AG 1993 All Rights Reserved

The reproduction, transmission or use of this document or its contents is not permitted without express written authority.

Offenders will be liable for damages. All rights, including rights created by patent grant or registration of a utility model or design, are reserved.

Disclaimer of Liability

We have checked the contents of this manual for agreement with the hardware and software described. Since deviations cannot be excluded entirely, we cannot guarantee full agreement. However, the data in this manual are reviewed regularly and any necessary corrections included in subsequent editions. Suggestions for improvement are welcomed.

Technical data subject to change.

Safety-related guidelines

This manual contains certain notices which you should observe to ensure your own personal safety, as well as to protect the product and connected equipment. These notices are highlighted in the manual by a warning triangle and are marked as follows according to the level of danger:



Warning

indicates that death, severe personal injury or substantial damage to property **can** result if proper precautions are not taken.



Caution

indicates that minor personal injury or property damage can result if proper precautions are not taken.

Only **qualified personnel** should be allowed to install and work on this equipment. Qualified persons are defined as persons who are authorized to commission, to ground and to tag equipment, systems and circuits in accordance with established safety practices and standards.

How to Use this Manual

Safety information and ESD guidelines

In this manual you will find the "Safety information" on the rear of the front sheet and the "ESD (electrostatically sensitive devices) Guidelines" in the appendix. These must be exactly observed and followed whenever working with the CP 581.

README file

You can find information produced at a later date than the printing of this manual in the README.TXT file in directory C:\CP581 on the hard disk of the CP 581. You can read and/or print this file using any word processing program.

Scope

The manual describes the following versions of the CP 581 and the associated CP 581 system software:

a) Hardware versions

6ES5 581-0EA11	CP 581 basic board, 4 Mbytes, without onboard silicon disk
6ES5 581-1EA11	CP 581 basic board, 4 Mbytes, with onboard silicon disk
6ES5 581-0LA11	CP 581 mass storage module, 60 Mbytes
6ES5 581-1LA11	CP 581 mass storage module, 120 Mbytes
6ES5 581-0RA11	CP 581 AT-slot module
6ES5 581-0RA12	CP 581 AT-slot module (for CP 581/486)
6ES5 581-0EB11	CP 581/486 basic board without onboard silicon disk
6ES5 581-1EB11	CP 581/486 basic board with onboard silicon disk

b) CP 581 system software

6ES5 835-8MDxx	Version 6ES5 835-8MD01 onwards
----------------	--------------------------------

How the Manual is Organized

The manual is divided into two volumes:

- Volume 1 describes the installation and commissioning of the CP 581 and contains detailed information on the hardware in the form of a reference section.
- Volume 2 describes how you can use the CP 581 system software for your applications and provides information on use of the various functions. A reference section contains additional important information on the various applications.

Information on use of Volume 1:

Volume 1 is divided into two main parts:

Chapters 1 and 2 are *task-oriented* and describe in sequential order the work which you must carry out as the user.

Chapters 3 to 6 are *system-oriented*; they provide information in compressed form and can be used as a reference work by users with all stages of knowledge.

The Manual is thus suitable for first-time users and also as a reference work for experienced users. You can ignore parts of the manual depending on your knowledge and the application, and concentrate on the relevant parts.

The contents of the individual chapters are summarized below to help you become acquainted with Volume 1:

- Chapter 1** The **Introduction to Application of the CP 581** describes the facilities provided by the CP 581 and describes ranges of application.
- Chapter 2** describes the scope of delivery of the CP 581 components, peripheral configurations and the mechanical assembly of the CP 581 components into a complete module. You are also informed on all details of **Installation** of the hardware and **Commissioning** of the software.
- Chapter 3** The **Reference Section for Hardware** (device description) contains all important information on the hardware components of the CP 581. Each component is described separately. This chapter also contains the SETUP description and information for developers of own system software.

- Chapter 4** lists the **Technical Data** of the CP 581. You will find data on e.g. the current consumption, electromagnetic compatibility and the climatic and mechanical environmental conditions.
- Chapter 5** contains the Appendix, a list of abbreviations, a subject index, and a list of tables and figures.
- Chapter 6** contains **Ordering Information** for accessories and peripheral devices (state at time of printing of manual).

Contents

1	Introduction to Application of the CP 581	1 - 3
1.1	What is a CP 581 and What Facilities Does it Provide You With?	1 - 3
1.2	What Applications are Possible for the CP 581?	1 - 5
1.3	What Tasks can the CP 581 Handle in an Automation Network?	1 - 9
2	Installation and Commissioning	2 - 5
2.1	Unpacking and Checking the Delivered Components	2 - 5
2.1.1	Standard Scope of Delivery of Basic Board	2 - 5
2.1.2	Standard Scope of Delivery of Mass Storage Module	2 - 6
2.1.3	Standard Scope of Delivery of AT-slot Module	2 - 7
2.1.4	Standard Scope of Delivery of Remote Terminal Interface (RTI)	2 - 7
2.1.5	Y Adapter	2 - 7
2.1.6	Light Pen	2 - 8
2.2	General Information on Commissioning of the CP 581	2 - 9

2.3	Connectable Peripheral Devices/Interface Configuration	2 - 10
2.3.1	Configuration 1: Short Distance CP 581 ↔ Operator Console	2 - 10
2.3.2	Configuration 2: Long Distance CP 581 ↔ Operator Console	2 - 12
2.4	Checklist for Installation and Commissioning	2 - 14
2.5	Switch and Jumper Settings on the CP 581 Components	2 - 15
2.6	Assembly of Individual Components into Complete Module	2 - 17
2.6.1	Assembly of Memory Extension on Basic Board	2 - 17
2.6.2	Information on Assembly of Individual Components	2 - 18
2.6.3	Assembly of Mass Storage Module on Basic Board	2 - 20
2.6.3.1	Assembly Accessories for the Mass Storage Module	2 - 20
2.6.3.2	Assembly Procedure	2 - 22
2.6.4	Assembly of AT-slot Modules	2 - 24
2.6.4.1	Assembly Accessories for the AT-slot Modules	2 - 24
2.6.4.2	Assembly of an AT-slot Module onto the Basic Board	2 - 26
2.6.4.3	Assembly of two AT-slot Modules onto the Basic Board	2 - 28
2.6.4.4	Assembly of an AT-slot Module onto the Mass Storage Module	2 - 30
2.6.4.5	Assembly of two AT-slot Modules onto the Mass Storage Module	2 - 32
2.6.5	Assembly of an AT Board onto an AT-Slot Module	2 - 34
2.7	Installation of Complete Module into Subrack	2 - 36
2.7.1	Interference-free Hardware Configuration	2 - 36
2.7.2	Selection of CP 581 Slots in the Programmable Controller	2 - 39
2.7.3	Switching Off the Power Supply of the PLC Rack	2 - 43
2.7.4	Installation of CP 581 into PLC Rack	2 - 43
2.8	Connection of Operation Devices and Peripheral Devices	2 - 45
2.8.1	Connection of Keyboard	2 - 46
2.8.2	Connection of Monitor	2 - 47
2.8.3	Connection of a Printer	2 - 50
2.8.4	Connection of a Mouse	2 - 51
2.8.5	Connection of a Light Pen	2 - 51
2.8.6	Maximum Cable Lengths for Connection of Operation Devices and Peripheral Devices	2 - 52

2.9	Commissioning	2 - 53
2.10	Installation and Commissioning of Software	2 - 55
2.10.1	Installation with Mass Storage Module	2 - 55
2.10.2	SETUP for Individual Operation of the CP 581 Basic Board with Silicon Disk	2 - 60
2.11	CPLINK	2 - 67
2.11.1	Use, Functions and Structure of CPLINK	2 - 67
2.11.2	Installation of CPLINK	2 - 70
2.11.3	PG Functions on Basis of CPLINK	2 - 75
2.11.4	Technical Information	2 - 77
2.11.4.1	Establishing/clearing the Connection	2 - 77
2.11.4.2	Limitations with DOS Functions	2 - 79
2.11.4.3	Further Reading	2 - 80
3	Reference Section for Hardware	3 - 5
3.1	Basic Board	3 - 6
3.1.1	Mechanical Construction	3 - 6
3.1.2	Controls and Displays	3 - 10
3.1.3	Switch and Jumper Settings	3 - 13
3.1.4	Connection of Printers	3 - 17
3.1.5	Connection of Keyboard	3 - 18
3.1.6	Connection of a Mouse	3 - 18
3.1.7	Connection of a Light Pen	3 - 19
3.1.8	Connection of a Monitor	3 - 19
3.1.9	External Interface Assignments	3 - 19
3.1.9.1	Combined Plug X6 for the Serial Interfaces COM 1 and COM 3	3 - 20
3.1.9.2	Combined Plug X7 for the Keyboard and Serial Interface COM 2 (Mouse)	3 - 22
3.1.9.3	Plug X15 for a Memory Card	3 - 23
3.1.9.4	Video Outputs	3 - 27

3.1.10	Internal Interface Assignments	3 - 28
3.1.10.1	Backplane Connectors X1 and X2	3 - 28
3.1.10.2	Interface for Expanded Memory, Connectors X4 and X8 (CP 581)	3 - 31
3.1.10.3	Interface for Expanded Memory, Connectors X4 and X8 (CP 581/486)	3 - 33
3.1.10.4	Internal, Expanded ISA Bus Connector X10	3 - 35
3.1.11	Memory and Hardware Interrupt Assignments	3 - 37
3.1.11.1	Memory Assignments	3 - 37
3.1.11.2	Hardware Interrupts	3 - 40
3.2	Mass Storage Module	3 - 41
3.2.1	Mechanical Construction	3 - 41
3.2.2	Positions of Floppy Disk Drive and Interfaces on Front Panel	3 - 43
3.2.3	Floppy Disk Drive	3 - 44
3.2.4	Hard Disk Drive	3 - 44
3.2.5	Switch and Jumper Settings	3 - 45
3.2.6	Connection of Devices to Centronics Interface (LPT)	3 - 47
3.2.7	Connection of Devices to the Serial Interface COM 4	3 - 47
3.2.8	External Interface Assignments of Mass Storage Module	3 - 47
3.2.8.1	Parallel Interface (LPT)	3 - 47
3.2.9	Serial Interface COM 4	3 - 49
3.2.10	Internal Interface Assignments	3 - 51
3.2.10.1	Backplane Connectors X1 and X2	3 - 51
3.2.10.2	Internal, Expanded ISA Bus Connector X10	3 - 52
3.3	AT-slot Module	3 - 53
3.3.1	Mechanical Construction of AT-slot Module	3 - 53
3.3.2	Switch and Jumper Settings	3 - 55
3.3.3	External Interface Assignments	3 - 56
3.3.4	Internal Interface Assignments	3 - 59

3.4	Remote Terminal Interface	3 - 61
3.4.1	Power Supply of RTI via Remote Supply from CP 581	3 - 64
3.4.2	Power Supply of RTI by Local, External Supply	3 - 64
3.4.3	Connection of Keyboard to the RTI	3 - 64
3.4.4	Connection of a Mouse to the RTI	3 - 64
3.4.5	Connection of a Light Pen to the RTI (CP 581/486)	3 - 65
3.4.6	Interface and Pin Assignments on the RTI	3 - 65
3.4.7	Connection Cable CP 581 ↔ RTI	3 - 66
3.5	Y Adapter	3 - 69
3.5.1	Assignments of Y Adapter Keyboard/COM 2	3 - 69
3.5.2	Assignments of Y Adapter COM 1/COM 3	3 - 70
3.6	Silicon Disk	3 - 72
3.6.1	Drive Assignments of Silicon Disks	3 - 73
3.6.2	Formatting of Silicon Disks	3 - 74
3.7	SETUP	3 - 77
3.7.1	Starting with Default Device Configuration for the CP 581 Basic Version	3 - 77
3.7.2	Restart of CP 581 with Modified Device Configuration	3 - 77
3.7.3	Restart of CP 581 with Memory Function for the SETUP Setting	3 - 83
3.7.4	BIOS S5 Page	3 - 85
3.7.5	BIOS Options Page (CP 581)	3 - 89
3.7.6	BIOS Options Page (CP 581/486)	3 - 95
3.8	Conversion and Repairs	3 - 99
3.9	Information for Developers of Own System Software	3 - 100
3.9.1	S5 Interface	3 - 100
3.9.2	Interrupt Processing on S5 Interface	3 - 110
3.9.3	Other Status Registers	3 - 114
3.9.4	Peripheral Byte Addressing	3 - 115

4	Technical Data of the CP 581	4 - 3
4.1	Basic Board	4 - 3
4.1.1	Device-specific Data	4 - 3
4.1.2	Power Supply	4 - 3
4.1.3	Current Consumption	4 - 3
4.1.4	Safety	4 - 4
4.1.5	Electromagnetic Compatibility (EMC)	4 - 4
4.1.6	Climatic Conditions	4 - 4
4.1.7	Mechanical Environmental Conditions	4 - 5
4.1.8	Logic Parameters	4 - 6
4.2	Mass Storage Module	4 - 10
4.2.1	Device-specific Data	4 - 10
4.2.2	Power Supply	4 - 10
4.2.3	Current Consumption	4 - 10
4.2.4	Safety	4 - 10
4.2.5	Electromagnetic Compatibility (EMC)	4 - 11
4.2.6	Climatic Conditions	4 - 11
4.2.7	Mechanical Environmental Conditions	4 - 12
4.2.8	Logic Parameters	4 - 13
4.3	AT-slot Module	4 - 14
4.3.1	Device-specific Data	4 - 14
4.3.2	Power Supply	4 - 14
4.3.3	Current Consumption	4 - 14
4.3.4	Maximum Loading of AT-slot Modules by AT Interfaces	4 - 15
4.3.5	Safety	4 - 16
4.3.6	Electromagnetic Compatibility (EMC)	4 - 17
4.3.7	Climatic Conditions	4 - 17
4.3.8	Mechanical Environmental Conditions	4 - 18
4.3.9	Permissible Dimensions of AT Modules	4 - 18

4.4	RTI Module	4 - 19
4.4.1	Device-specific Data	4 - 19
4.4.2	Power Supply	4 - 21
4.4.3	Current Consumption	4 - 21
4.4.4	Safety	4 - 21
4.4.5	Electromagnetic Compatibility (EMC)	4 - 22
4.4.6	Climatic Conditions	4 - 22
4.4.7	Mechanical Environmental Conditions	4 - 22
5	Appendix	5 - 1
	List of Abbreviations	5 - 3
	Index	5 - 5
	List of Tables and Figures	5 - 7
	List of Tables	5 - 7
	List of Figures	5 - 9
6	Ordering Information	6 - 3
	CP 581 components	6 - 3
	CP-581/486 components	6 - 3
	Extensions for the basic board CP 581	6 - 4
	Extensions for the basic board CP 581/486	6 - 4
	Remote terminal interface (RTI)	6 - 4
	Light pen	6 - 4
	Connection cables and adapters	6 - 5
	Memory cards	6 - 5

CP 581 software	6 - 6
SIMATIC S5 STEP 5 programming package and PG connection cable ...	6 - 7
Manuals	6 - 7
Printers	6 - 8
Interface modules and character set modules	6 - 8
Standard cable connectors	6 - 9
PG keyboard and mouse	6 - 9
Monitors	6 - 10
Monitor cable	6 - 10
Coax midi socket	6 - 10
Length codes for monitor cable	6 - 11
S5-115U	6 - 12

Introduction to Application of the CP 581

1



Contents of Chapter 1

1.1	What is a CP 581 and What Facilities Does it Provide You With?	1 - 3
1.2	What Applications are Possible for the CP 581?	1 - 5
1.3	What Tasks can the CP 581 Handle in an Automation Network?	1 - 9

1 Introduction to Application of the CP 581

This chapter provides you with an initial overview of the CP 581. You will learn:

- what a CP 581 is, and what facilities it provides you with,
- what applications are possible for the CP 581,
and
- what tasks the CP 581 handles in an automation network.

1

1.1 What is a CP 581 and What Facilities Does it Provide You With?

The CP 581 is an AT computer compatible with the industrial standard. It is fitted in your programmable controller subrack.

It consists of hardware modules which you can combine in certain configurations:

- Basic board with 80386SL or 80486SL and with silicon disk
(as option with memory card and/or onboard silicon disk)
- Mass storage module with floppy disk drive and hard disk
- AT-slot module for insertion of a short AT board.

You can operate the CP 581 in the following hardware configurations:

- a) Only with basic board
- b) With basic board and mass storage module
- c) With basic board, mass storage module and one AT-slot module
- d) With basic board, mass storage module and two AT-slot modules
- e) With basic board and one AT-slot module
or
- f) With basic board and two AT-slot modules.

The memory card can be addressed using MS-DOS just like a floppy disk drive, the onboard silicon disk just like a hard disk.

You can order the memory card as a "**Flash card**" or a "**RAM card**" (see "Ordering Information").

Note that when using a RAM card, the data you have saved on the card will be lost as soon as you remove the RAM card from the CP 581 or remove the CP 581 from the PLC rack.

You require a mass storage module for installation of the system software, but you can connect this module to a different CP 581 following the installation. If you wish to operate the basic board on its own or together with one or two AT-slot modules, you must transfer your software to a memory card or to the onboard silicon disk.

To do this you can also use the CPLINK program, with which you can load your software from a PG/PC to the CP 581.

The CP 581 provides you with additional computing performance in conjunction with the S5 CPU in order to solve your automation task. Direct communication with the S5 CPU via the internal S5 backplane bus enables effective data transfer between the S5 CPU and the CP 581.

To enable a meaningful distribution of tasks between the components of the programmable controller, the S5 CPU is assigned execution of the control tasks, whereas the CP 581 handles the acquisition, storage, management and conditioning of larger quantities of data. Standard MS-DOS user programs can be used for these functions of the CP 581. The software required for this comprises the MS-DOS operating system and a number of utilities specific to the CP 581 for communication between the MS-DOS and S5 environments.

1.2 What Applications are Possible for the CP 581?

The possible applications of the CP 581 can be divided into the five system functions:

- Process data acquisition
- Mass storage functions
- Command interpreter
- Virtual S5 drive

and

- Free programming.

1

Note



You can use the STEP 5 basic package for PCs when using the CP 581 with a basic board and mass storage module (see Chapter 6, Ordering Information).

Process data acquisition

Examples of applications of the process data acquisition function:

- Recording of process data and subsequent processing using standard MS-DOS programs
 - to evaluate and analyze the process
 - for central management of process data
 - for long-term quality monitoring
 - for statistics (data compression, short-term storage, quality assurance, optimization).
- Evaluation of measured data in conjunction with a modular message printing system:
 - for continuous monitoring of binary process signals
 - for monitoring of process operations
 - to unload the CPU of the programmable controller system in the case of comprehensive logging operations.
- Handling of data management for all programmable controllers in networked systems to unload the user memory on the S5 CPU.

Mass storage functions

Examples of applications of the mass storage functions:

- Transfer of larger quantities of process data to unload the user memory on the S5 CPU.
- Buffering of process data should the next higher computer level fail to prevent data losses.
- Recipe management in weighing and dosing systems (quantity control) to transfer recipes which are not currently required to the memory of the CP 581.

Command interpreter

Examples of applications of the command interpreter function:

- Calling of MS-DOS commands from the S5 CPU to activate programs for execution on the CP 581.
- Printing of S5 CPU messages on a message printer for storage of status and error messages.

1

Virtual S5 drive

Examples of applications of the virtual S5 drive function:

- Access to S5 data blocks from the CP 581
 - for simple handling using MS-DOS commands (e.g. DIR, TYPE, PRINT, COPY)
 - for adaptation of existing programs for data transfer with S5 data blocks using MS-DOS file functions
 - For free programming with data blocks, e.g. in C with "fopen()", "fread()", "fwrite()", etc., for data exchange with S5 data blocks.

Free programming

Examples of applications of the free programming function:

- Use of self-generated applications in ASM, C, PASCAL, etc.
 - for optimum adaptation of your programmable controller system to the tasks
 - for adaptation of existing programs to communication via the S5 backplane bus
 - to implement the cell level of a manufacturing system according to Fig. 1.1.

CPLINK

Examples of applications of the CPLINK function:

- Loading the onboard silicon disk or memory card from a PG/PC in remote operation; the memory of the CP 581 can be completely "empty".
- Physical link to the PG via the COM1 serial interface.
- Access from the PG/PC to the CP 581 via two additional logical drives.

1.3 What Tasks can the CP 581 Handle in an Automation Network?

The CP 581 as a computer local to the process can establish connections between the process, i.e. the manufacturing operations, on the one hand and the computers of the coordinating and planning levels, i.e. the management, on the other.

Fig. 1.1 shows a possible task of the CP 581 in the automation pyramid.

1

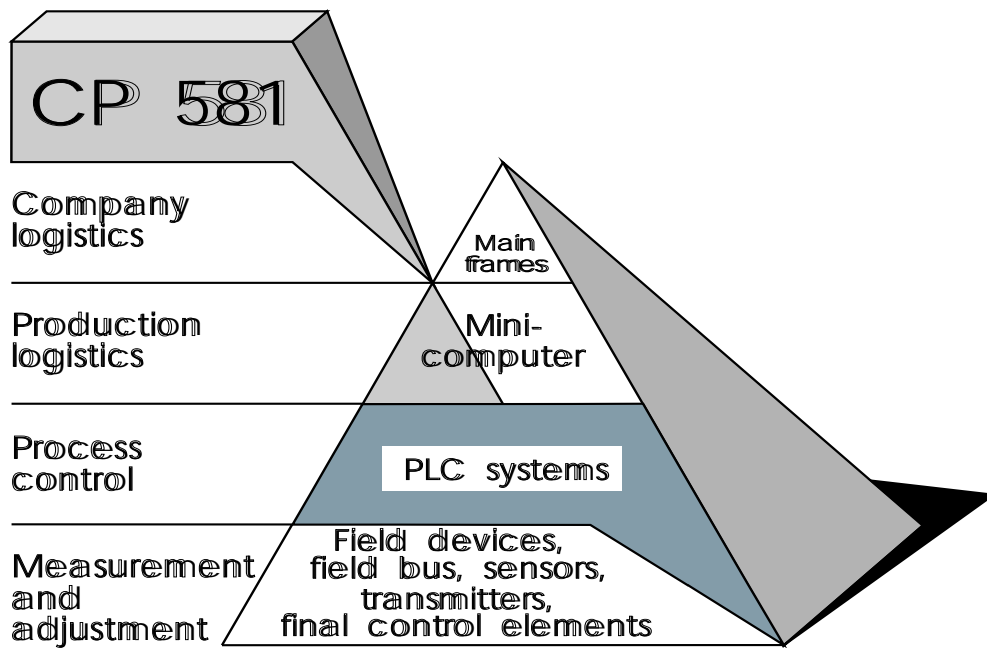

Fig. 1.1 The CP 581 communications processor in the automation pyramid

Installation and Commissioning

2

2

Contents of Chapter 2

2.1	Unpacking and Checking the Delivered Components	2 - 5
2.1.1	Standard Scope of Delivery of Basic Board	2 - 5
2.1.2	Standard Scope of Delivery of Mass Storage Module	2 - 6
2.1.3	Standard Scope of Delivery of AT-slot Module	2 - 7
2.1.4	Standard Scope of Delivery of Remote Terminal Interface (RTI)	2 - 7
2.1.5	Y Adapter	2 - 7
2.1.6	Light Pen	2 - 8
2.2	General Information on Commissioning of the CP 581	2 - 9
2.3	Connectable Peripheral Devices/Interface Configuration	2 - 10
2.3.1	Configuration 1: Short Distance CP 581 ↔ Operator Console	2 - 10
2.3.2	Configuration 2: Long Distance CP 581 ↔ Operator Console	2 - 12

2.4	Checklist for Installation and Commissioning	2 - 14
2.5	Switch and Jumper Settings on the CP 581 Components	2 - 15
2.6	Assembly of Individual Components into Complete Module	2 - 17
2.6.1	Assembly of Memory Extension on Basic Board	2 - 17
2.6.2	Information on Assembly of Individual Components	2 - 18
2.6.3	Assembly of Mass Storage Module on Basic Board	2 - 20
2.6.3.1	Assembly Accessories for the Mass Storage Module	2 - 20
2.6.3.2	Assembly Procedure	2 - 22
2.6.4	Assembly of AT-slot Modules	2 - 24
2.6.4.1	Assembly Accessories for the AT-slot Modules	2 - 24
2.6.4.2	Assembly of an AT-slot Module onto the Basic Board	2 - 26
2.6.4.3	Assembly of two AT-slot Modules onto the Basic Board	2 - 28
2.6.4.4	Assembly of an AT-slot Module onto the Mass Storage Module	2 - 30
2.6.4.5	Assembly of two AT-slot Modules onto the Mass Storage Module	2 - 32
2.6.5	Assembly of an AT Board onto an AT-Slot Module	2 - 34
2.7	Installation of Complete Module into Subrack	2 - 36
2.7.1	Interference-free Hardware Configuration	2 - 36
2.7.2	Selection of CP 581 Slots in the Programmable Controller	2 - 39
2.7.3	Switching Off the Power Supply of the PLC Rack	2 - 43
2.7.4	Installation of CP 581 into PLC Rack	2 - 43
2.8	Connection of Operation Devices and Peripheral Devices	2 - 45
2.8.1	Connection of Keyboard	2 - 46
2.8.2	Connection of Monitor	2 - 47
2.8.3	Connection of a Printer	2 - 50
2.8.4	Connection of a Mouse	2 - 51
2.8.5	Connection of a Light Pen	2 - 51
2.8.6	Maximum Cable Lengths for Connection of Operation Devices and Peripheral Devices	2 - 52

2.9 Commissioning2 - 53

2.10 Installation and Commissioning of Software2 - 55

2.10.1 Installation with Mass Storage Module2 - 55

2.10.2 SETUP for Individual Operation of the CP 581 Basic Board
with Silicon Disk2 - 60

2.11 CPLINK2 - 67

2.11.1 Use, Functions and Structure of CPLINK2 - 67

2.11.2 Installation of CPLINK2 - 70

2.11.3 PG Functions on Basis of CPLINK2 - 75

2.11.4 Technical Information2 - 77

2.11.4.1 Establishing/Clearing the Connection2 - 77

2.11.4.2 Limitations with DOS Functions2 - 79

2.11.4.3 Further Reading2 - 80



2 Installation and Commissioning

This chapter describes the installation and commissioning of the CP 581. Please also observe the installation guidelines described in this chapter.

2.1 Unpacking and Checking the Delivered Components

1. Unpack the CP 581 components.
2. Retain the original packing material for subsequent transport.

2

This manual was ordered separately. Please observe the language-specific order nos. (see Chapter 6, Ordering Information).

2.1.1 Standard Scope of Delivery of Basic Board

Check the scope of delivery!

On delivery the CP 581 basic board includes:

- CP 581 basic board: hardware.

Check that the order no. printed on your CP 581 basic board agrees with the configuration you ordered.

CP 581 basic board configurations:

6ES5 581-0EA11	CP 581 basic board without onboard silicon disk
6ES5 581-1EA11	CP 581 basic board with onboard silicon disk
6ES5 581-0EB11	CP-581/486 basic board without onboard silicon disk
6ES5 581-1EB11	CP-581/486 basic board with onboard silicon disk

Extensions for the basic board:

6ES5 581-OHA11	Memory extension to 8 Mbytes for CP 581
6ES5 581-OKA11	80387SL coprocessor
6ES5 581-OHB11	Memory extension to 20 Mbytes for CP 581/486

2.1.2 Standard Scope of Delivery of Mass Storage Module

Check the scope of delivery!

On delivery the CP 581 mass storage module includes:

- CP 581 mass storage module
- and
- assembly kit.

CP 581 mass storage module configurations:

6ES5 581-0LA11	60-Mbyte mass storage module
6ES5 581-1LA11	120-Mbyte mass storage module



Note

The CP 581 mass storage module is equipped with a disk drive which is sensitive to shock and vibration. Please remember this when handling the system.
Only transport this module in its original packing material!

2.1.3 Standard Scope of Delivery of AT-slot Module

Check the scope of delivery!

On delivery the CP 581 AT-slot module includes:

- CP 581 AT-slot module
- and
- assembly kit.

2.1.4 Standard Scope of Delivery of Remote Terminal Interface (RTI)

2

Check the scope of delivery!

On delivery the remote terminal interface includes:

- RTI module.

You additionally require the

- Connection cable for RTI

listed in Chapter 6, Ordering Information.

2.1.5 Y Adapter

You require so-called Y adapters to connect a keyboard, a mouse or a light pen and devices with standard plugs:

- Y adapter for keyboard/mouse with:
 - 26-pin high-density plug for connection to the Keyboard/COM 2 interface of the CP 581
 - 7-way round socket for connection of a keyboard
 - 9-pin D-subminiature plug for connection of a mouse or light pen.

- Y adapter for devices with standard plugs for serial interfaces with:
 - 26-pin high-density plug for connection to the COM 1/COM 3 or COM 4 interface of the CP 581
 - 25-pin subminiature plug for the COM 1 interface
 - 25-pin subminiature plug for the COM 3 interface.

You will find the order nos. for the Y adapters in Chapter 6, Ordering Information.

2.1.6 Light Pen

As an alternative to a mouse you can connect a SIEMENS light pen to the COM 2 interface of the CP 581 (or the RTI).

Modes:

- close operation: connect the light pen via a Y adapter to the COM 2 interface,
- remote operation: operation via RTI (max. 250m). Connect the light pen via the mouse interface.

The light pen is optional. You will find its order no. in Chapter 6, Ordering Information.

2.2 General Information on Commissioning of the CP 581

To run up the CP 581 you also need:

- MS-DOS package, version 5.0
- A monitor with
 - Cable connector for the monitor
 - Instructions for the monitor
- A PG 750 keyboard or an MF2 keyboard with equivalent functions with
 - Instructions for the keyboard.

2

The environmental conditions and technical data applicable to the CP 581 are listed in Chapter 4, Technical Data.

Note



It is essential to observe the current consumption of the CP 581 when equipping the programmable controller! This can be obtained from Chapter 4 "Technical Data".

2.3 Connectable Peripheral Devices/Interface Configuration

2.3.1 Configuration 1: Short Distance CP 581 ↔ Operator Console

Fig. 2.1 shows two examples of the connections possible to the CP 581 when using a basic board and a mass storage module in the interface configuration "Short distance CP 581 ↔ operator console".

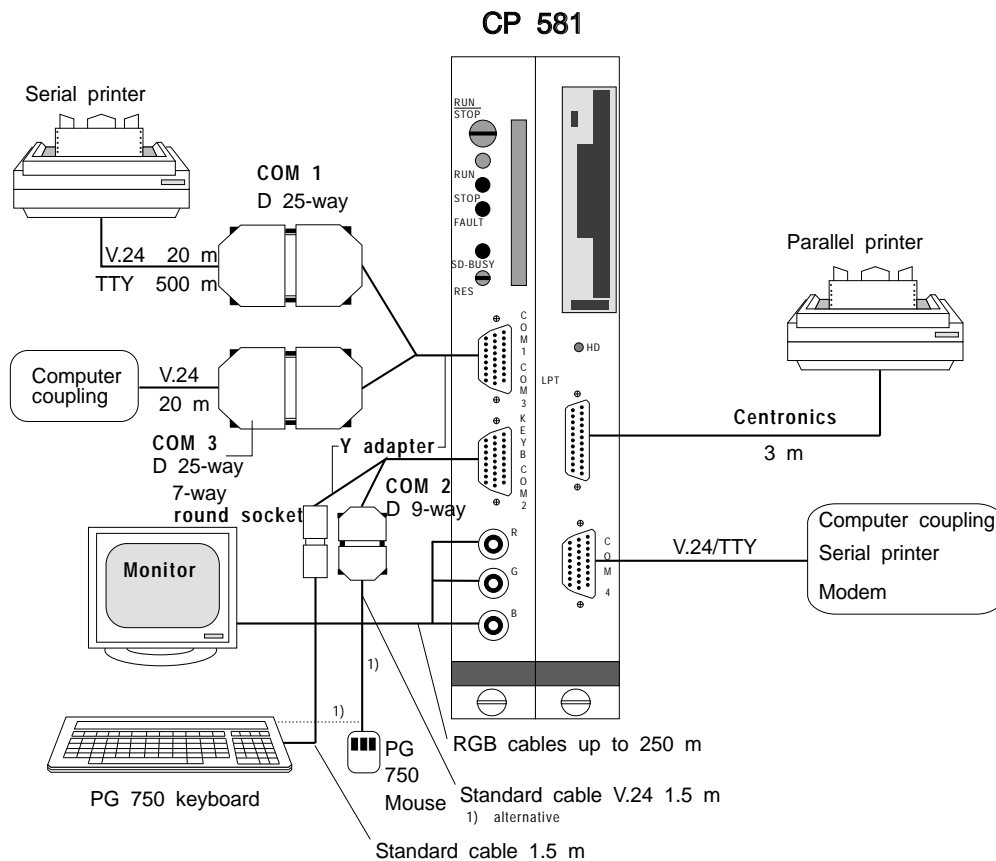
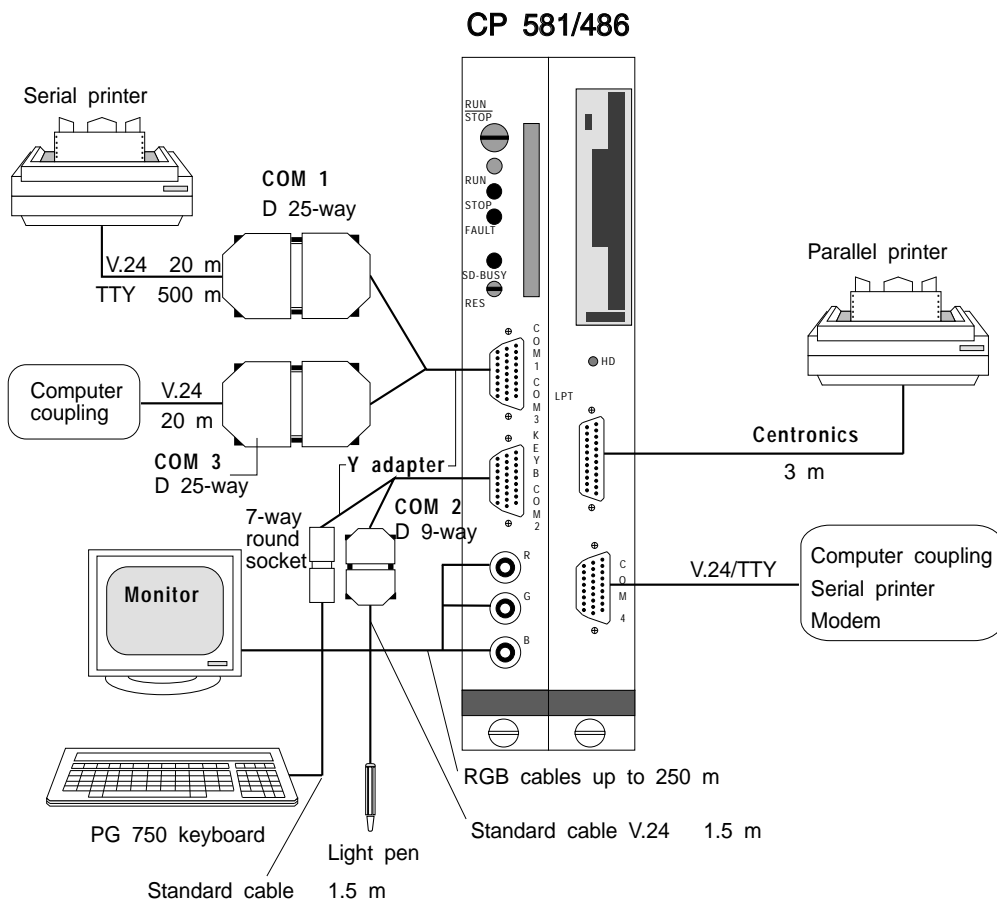

Fig. 2.1 Possible connections with keyboard, monitor, printer and mouse (configuration 1a)



2

Fig. 2.2 Possible connections with keyboard, monitor, printer and light pen (configuration 1b)

2.3.2 Configuration 2: Long Distance CP 581 ↔ Operator Console

Fig. 2.2 shows two examples of the connections possible to the CP 581 when using a basic board and a mass storage module in the interface configuration "Long distance CP 581 ↔ operator console".

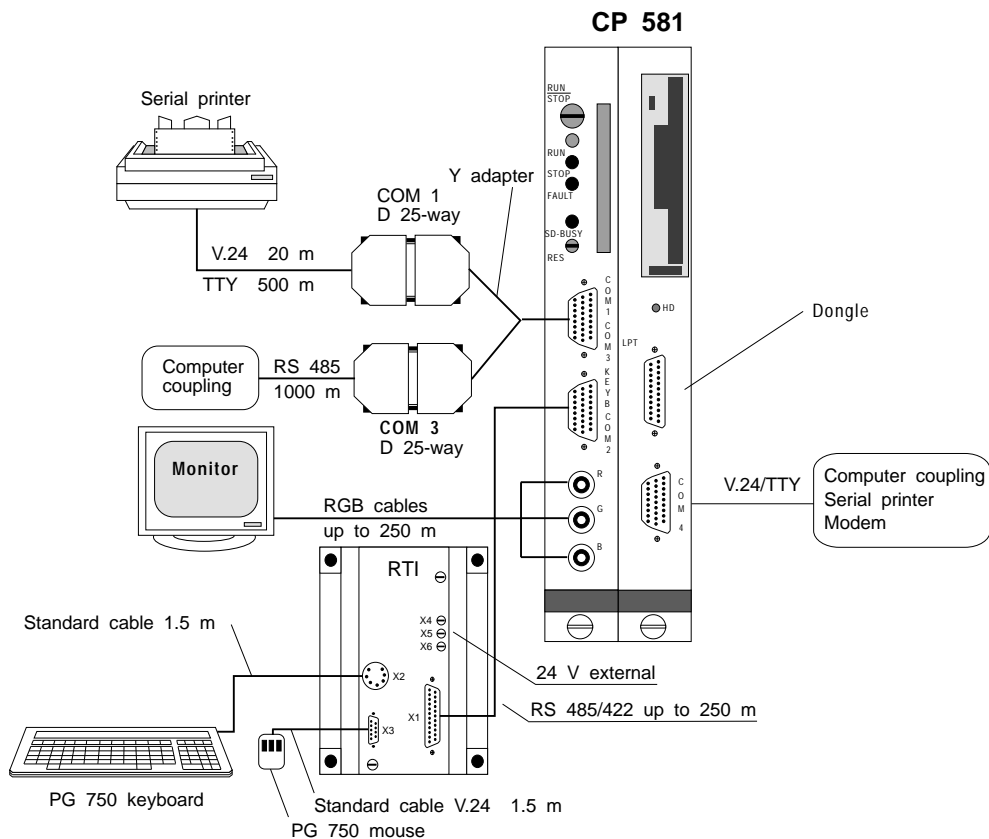
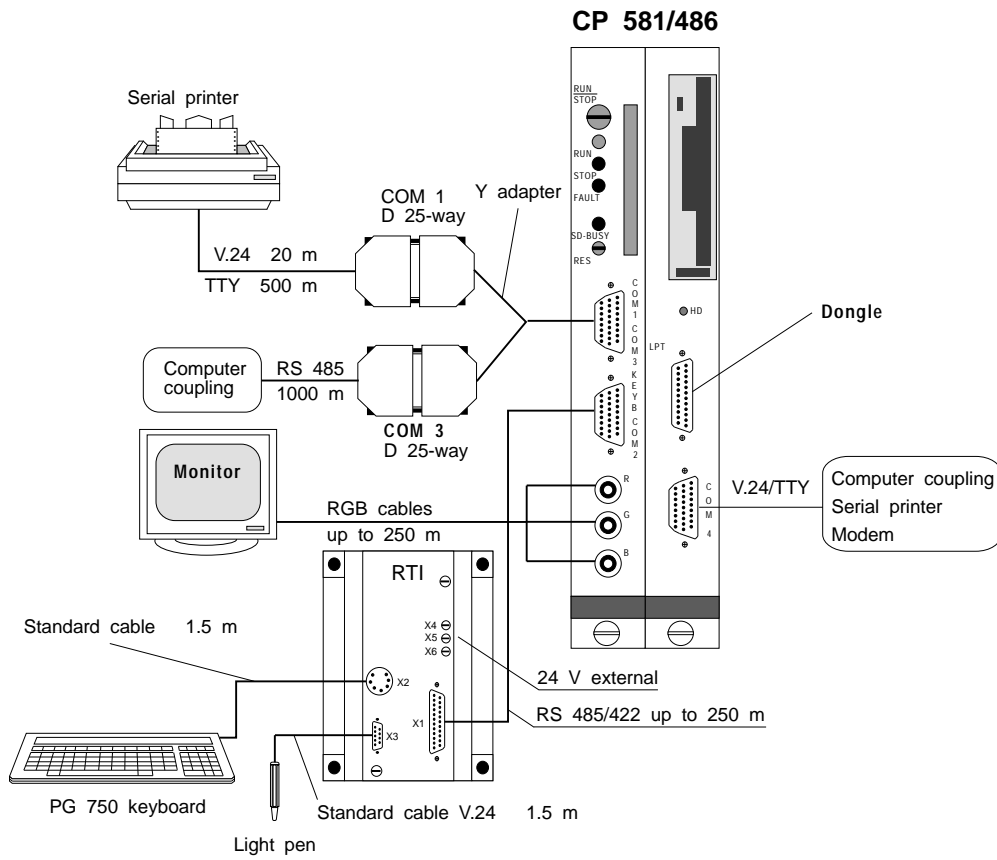

Fig. 2.3 Possible connections with keyboard, monitor, printer and mouse (configuration 2a)



2

Fig. 2.4 Possible connections with keyboard, monitor, printer and light pen (configuration 2a)

2.4 Checklist for Installation and Commissioning

This section explains the procedure for installing and setting up the CP 581 components step-by-step. Please proceed as described below.

1. Is the power supply unit in your subrack correctly dimensioned?
2. Fit the CP 581 components to produce the complete CP 581 module.
3. Switch off the power supply to your programmable controller rack and insert the complete CP 581 module into the provided slot.
4. Check the position of the mode switch. The switch must be in the RUN position.
5. Connect the required operation devices and peripheral devices.
6. Switch the peripheral devices on.
7. Switch the power supply to your programmable controller rack on again.
8. Set the date and time using the SETUP menu (when setting up for the first time).
9. Install MS-DOS.
10. Startup MS-DOS and generate back-up copies of MS-DOS and the CP 581 system software.
11. Install the CP 581 system software.
12. Startup the CP 581 system software.



Note

Please note that you require the mass storage module or the CPLINK program for installation of the system software when setting up for the first time. When further setting up, you can operate the basic board on its own.

2.5 Switch and Jumper Settings on the CP 581 Components

The coding switches and plug-in jumpers are factory-set on the basic board, mass storage module and AT-slot module. You need not carry out any checks or adjustments provided you wish to use the CP 581 components in their default configuration.



Note

You can refer to the functions of the coding switches and plug-in jumpers in the Reference Section for Hardware:
Section 3.1.3 for the basic board,
Section 3.2.5 for the mass storage module and
Section 3.3.2 for the AT-slot module.

2

2.6 Assembly of Individual Components into Complete Module

Caution



It is essential to observe the guidelines for handling electrostatically sensitive devices (ESD guidelines - see Appendix) when assembling the individual components.

2.6.1 Assembly of Memory Extension on Basic Board

2

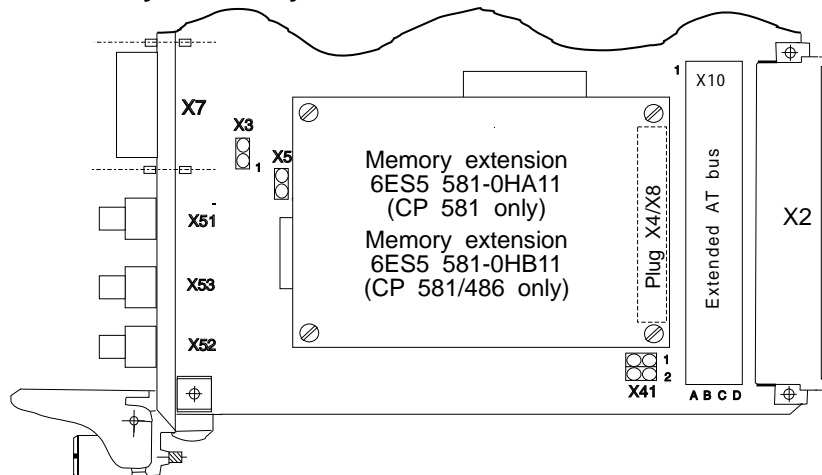

Fig. 2.5 Cross-section of basic board for installation of memory extension

If you wish to operate the basic board with a memory extension, fit this as follows:

1. Insert the memory extension into the slot provided on the basic board using plug X4/X8 (see Fig. 2.3).
2. Lock the memory extension by rotating the 4 screws by 1/8 revolution clockwise.
3. Stick the provided label of the memory extension onto the front panel of the basic board above the memory card slot.

2.6.2 Information on Assembly of Individual Components

The following sections describe the assembly of all possible combinations of the individual components:

- Mass storage module on basic board
 - 1 AT-slot module on basic board
 - 2 AT-slot modules on basic board
 - 1 AT-slot module on mass storage module
- and
- 2 AT-slot modules on mass storage module.

You are additionally informed of how you can equip an AT-slot module with an AT board.

The mass storage module and the AT-slot modules each have a set of accessories. These are indicated in the parts lists (Figs. 2.5 and 2.7). Each part in these Figs. is assigned a number which is referred to in the following assembly diagrams.

If you are looking for a part during assembly, you can find it in the corresponding parts list using its number.

Plugging together of modules with tongue and groove

The assembly instructions for the various combinations include a step for connecting the modules with a tongue and groove. Fig. 2.4 shows you how the modules are connected in this manner.

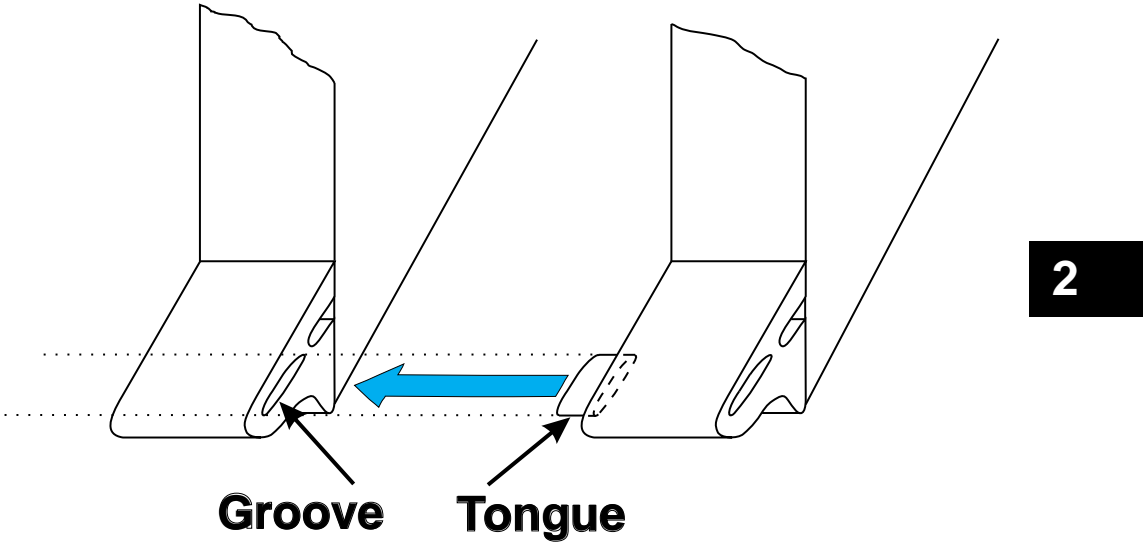

Fig. 2.6 Connection of modules using tongue and groove

2.6.3 Assembly of Mass Storage Module on Basic Board

2.6.3.1 Assembly Accessories for the Mass Storage Module

An assembly kit C79458-L965-D11 is supplied with the mass storage module. This set contains all screws and spacers required for assembling the basic board as well as a TORX offset screwdriver (see Fig. 2.5).

The numbers of the individual parts are used in the following assembly diagram.

Assembly kit C79458-L965-D11
for assembly of mass storage module

	Part No.	Quantity	Designation
	1	3	Spacer, 12.7 mm
	2	2	Spacer, 18.7 mm
	3	4	Screw, 6 mm long
	4	6	Screw, 12 mm long
		1	TORX offset screwdriver, M 2.5

2

Fig. 2.7 Assembly accessories for the mass storage module

2.6.3.2 Assembly Procedure

Proceed as follows according to Fig. 2.6 in order to assemble the modules:

1. Screw the spacers "1" and "2" onto the basic board according to Fig. 2.6. Insert the screws "3" and "4" from the solder side (the side of the module provided with a cover).
2. Plug the mass storage module onto the basic board, ensuring that the tongue on the eject lever of the mass storage module latches into the groove in the eject lever of the basic board (see Fig. 2.4). The plugs of the two modules must be completely connected together.
3. Screw the two modules together as in Fig. 2.6.
If you wish to fit the AT-slot module immediately, **do not fit** the screws identified "A".

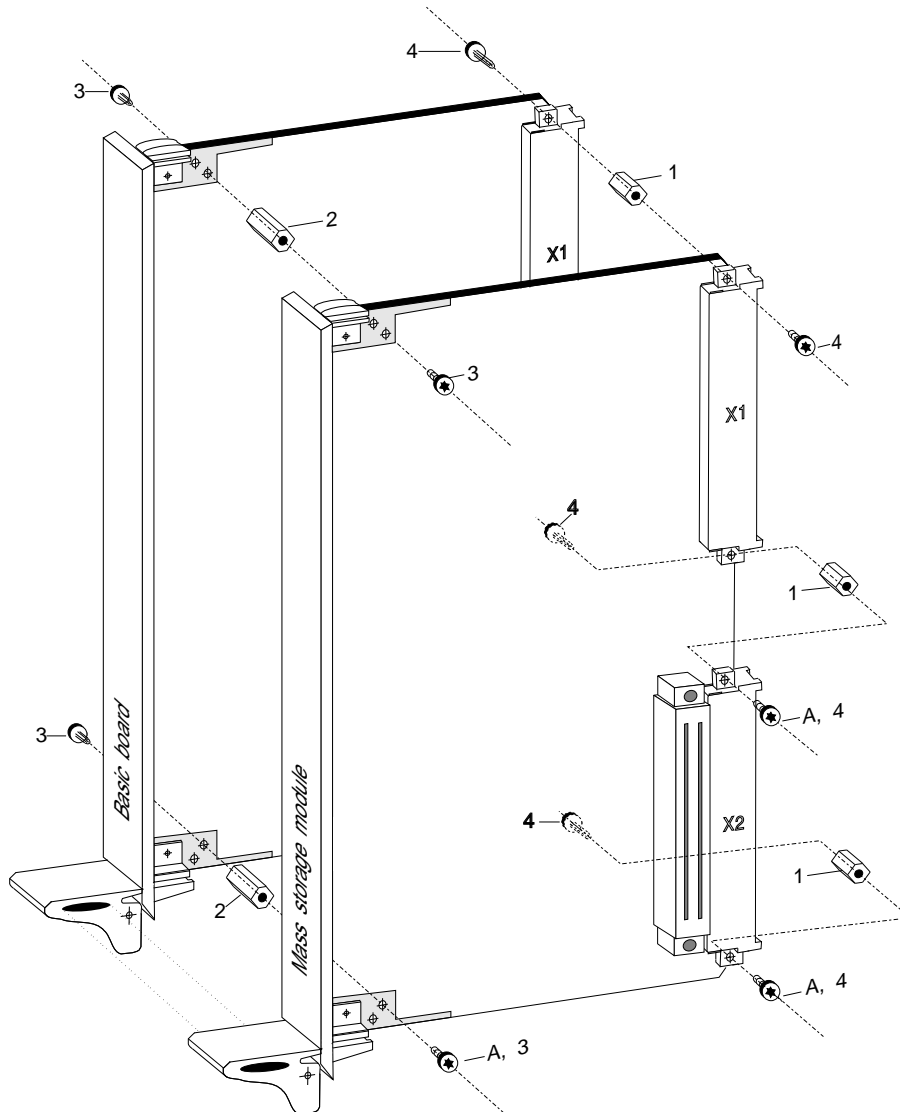

2

Fig. 2.8 Assembly of the mass storage module onto the basic board













2.6.4 Assembly of AT-slot Modules

2.6.4.1 Assembly Accessories for the AT-slot Modules

An assembly kit C79458-L965-D12 is supplied with each AT-slot module. This set contains all screws and spacers required for assembling the basic board, mass storage module or AT-slot module as well as a TORX offset screwdriver (see Fig. 2.7).

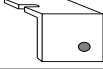
The numbers of the individual parts are used in the following assembly diagrams. Not all parts of the assembly kit are required depending on the configuration of the modules.

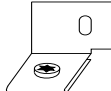
Assembly kit C79458-L965-D12
for assembly of AT-slot module

	Part No.	Quantity	Designation
	1	2	Spacer, 12.7 mm
	2	1	Spacer, 18.7 mm
	3	1	Spacer, 15.7 mm
	4	4	Spacer, 18.7 mm
	5	1	Spacer bolt, 17.7 mm
	6	2	Spacer bolt, 12.7 mm
	7	1	Spacer bolt, 17.7 mm
	8	8	Screw, 6 mm long
	9	2	Screw, 12 mm long
	10	1	Clamp
	11	1	Front panel, top
	12	1	Support
		1	TORX offset screwdriver, M 2.5

2

Fig. 2.9 Assembly accessories for the AT-slot modules

2.6.4.2 Assembly of an AT-slot Module onto the Basic Board

Proceed as follows according to Fig. 2.8 in order to assemble the modules:

1. Screw the spacer "2" and the spacer bolt "5" onto the basic board according to Fig. 2.8. Insert the screw "8" from the solder side (the side of the module provided with a cover). Make sure you use the inner hole of the two adjacent holes.
2. If you wish to fit a second AT-slot module immediately, screw the spacer identified "B" onto the first AT-slot module.
3. Plug the AT-slot module onto the basic board, ensuring that the tongue on the eject lever of the AT-slot module latches into the groove in the eject lever of the mass storage module (see Fig. 2.4). The plugs of the two modules must be completely connected together.
4. Attach clamp "10" onto the mounted system such that the right-hand edge of the basic board front panel extends into the slit of the clamp, and the clamp rests on the component side of the AT-slot module. Screw the clamp onto the module if you do not wish to fit a second AT-slot module.
5. If you do not wish to fit a further AT-slot module, screw the two modules together using the three screws identified "A" in Fig. 2.8 and fit the part "Front panel, top" ("11") onto the spacer bolt "5".

If you wish to fit a second AT-slot module immediately, proceed as described in Section 2.6.4.3.

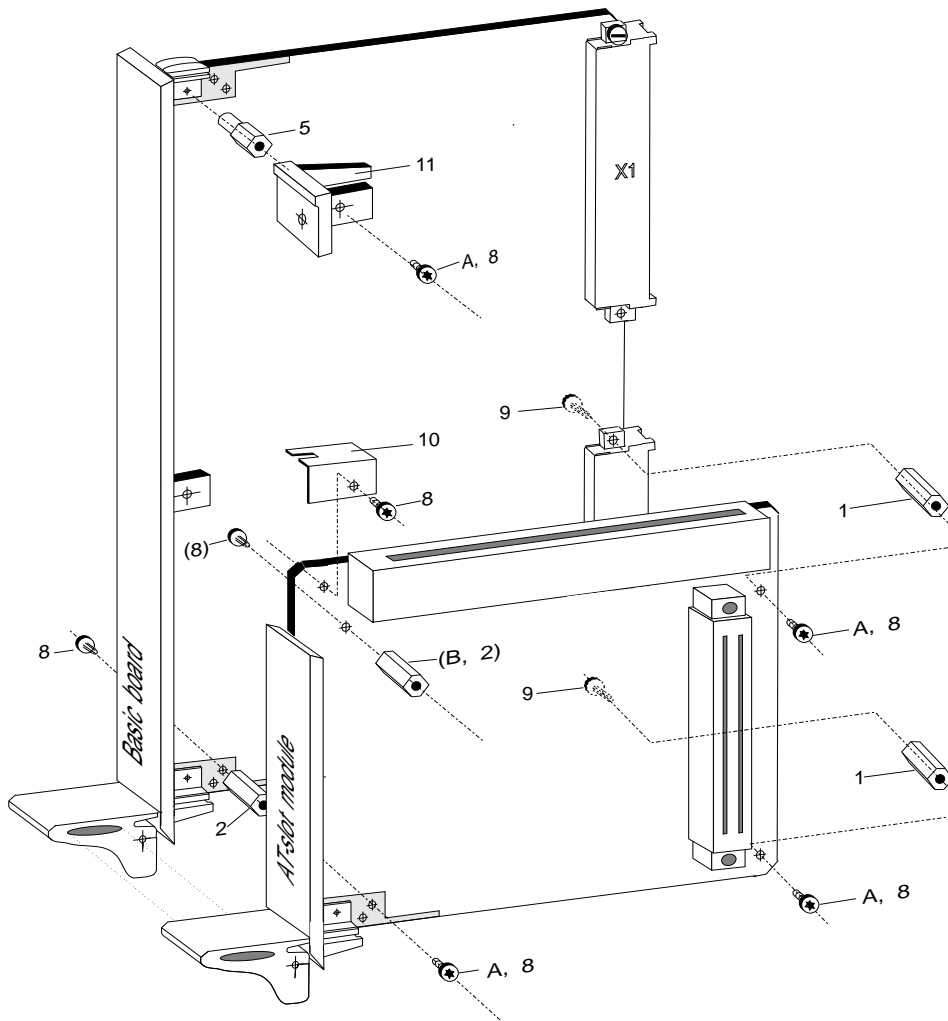

2

Fig. 2.10 Assembly of **one** AT-slot module onto the basic board

2.6.4.3 Assembly of two AT-slot Modules onto the Basic Board

Proceed as follows according to Fig. 2.9 in order to assemble the second AT-slot module:

1. If the first AT-slot module has already been fitted completely:
Remove the four screws identified "A". The screws are still required for the further assembly (identified by "A" in Fig. 2.9). Unscrew the clamp "B" and remove the first AT-slot module from the basic board.
2. Screw the spacer "C" onto the first AT-slot module, plug the basic board and the first AT-slot module together and screw on clamp "B". Screw the spacer bolts "4" into the first AT-slot module as in Fig. 2.9.
3. Plug the second AT-slot module onto the first AT-slot module, ensuring that the tongue on the eject lever of the second AT-slot module latches into the groove in the eject lever of the first AT-slot module (see Fig. 2.4). The plugs of the two modules must be completely connected together.
4. Screw the two AT-slot modules together as in Fig. 2.9 using the three screws identified "A" and one screw identified "8".
5. Fit the first part "Front panel, top" onto the spacer bolts identified by "5" in Fig. 2.8; tighten the part using the spacer bolt "7" (Fig. 2.9). Using the fourth screw "4", subsequently fit the second part "Front panel, top" onto the spacer bolt "7" screwed in for securing the first part.

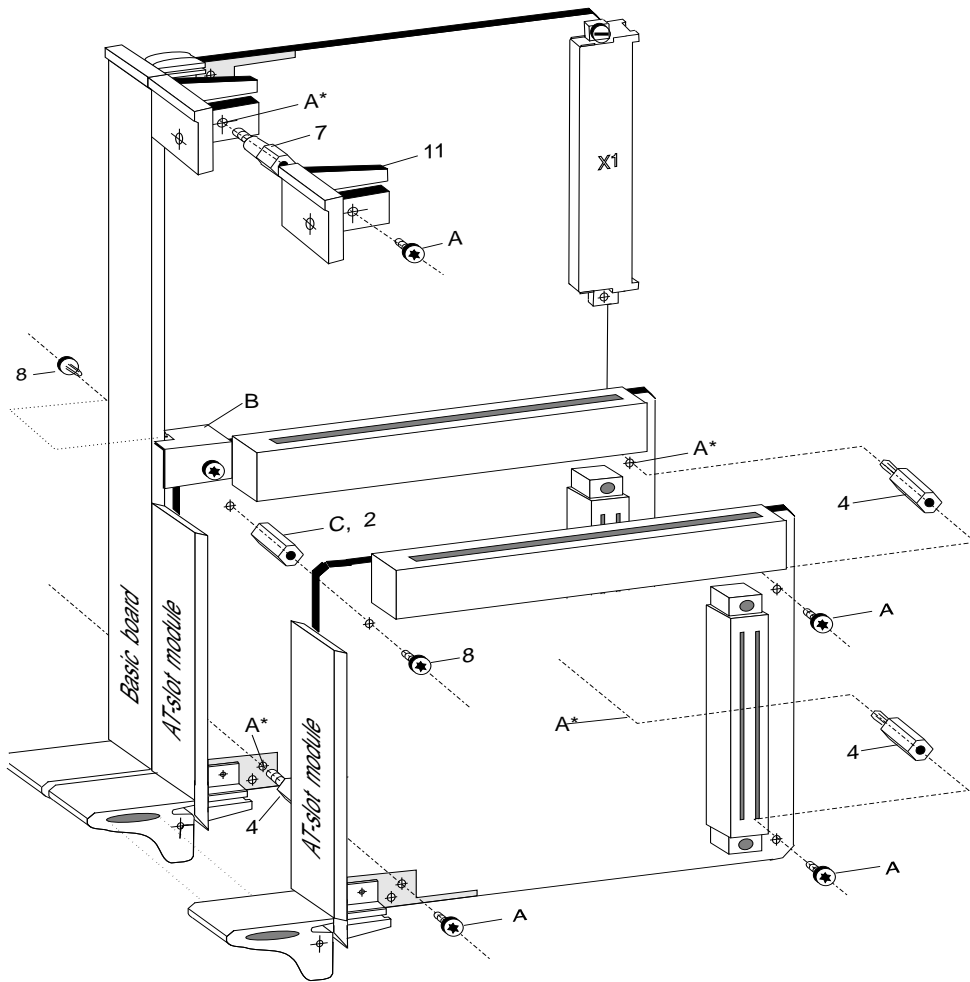

2

Fig. 2.11 Assembly of two AT-slot modules onto the basic board

2.6.4.4 Assembly of an AT-slot Module onto the Mass Storage Module

Proceed as follows according to Fig. 2.10 in order to assemble the modules:

1. If the mass storage module has already been fitted completely:
Loosen the two screws identified "A*" and "B*". Screw "A*" is required for the further assembly (identified by "A" in Fig. 2.10), screws "B*" are replaced by the screws identified by "A, 8" in Fig. 2.10.
2. Screw in the spacer bolts "3", "4" and "6" according to Fig. 2.10.
3. Plug the AT-slot module onto the mass storage module, ensuring that the tongue on the eject lever of the AT-slot module latches into the groove in the eject lever of the mass storage module (see Fig. 2.4). The plugs of the two modules must be completely connected together.
4. If you do not wish to fit a further AT-slot module, screw the two modules together using the screw identified "A" and the three screws identified "A, 8" in Fig. 2.10 and fit the part "Front panel, top" ("11") onto the spacer bolt "5" using a screw "A, 8".

If you wish to fit a second AT-slot module immediately, proceed as described in Section 2.6.4.5.



Note

If the spacer bolts "6" in Fig. 2.10 do not immediately grip when screwing in, slightly loosen the screws identified "4" in Fig. 2.6 (1/4 revolution), screw in the bolts and tighten the screws again.

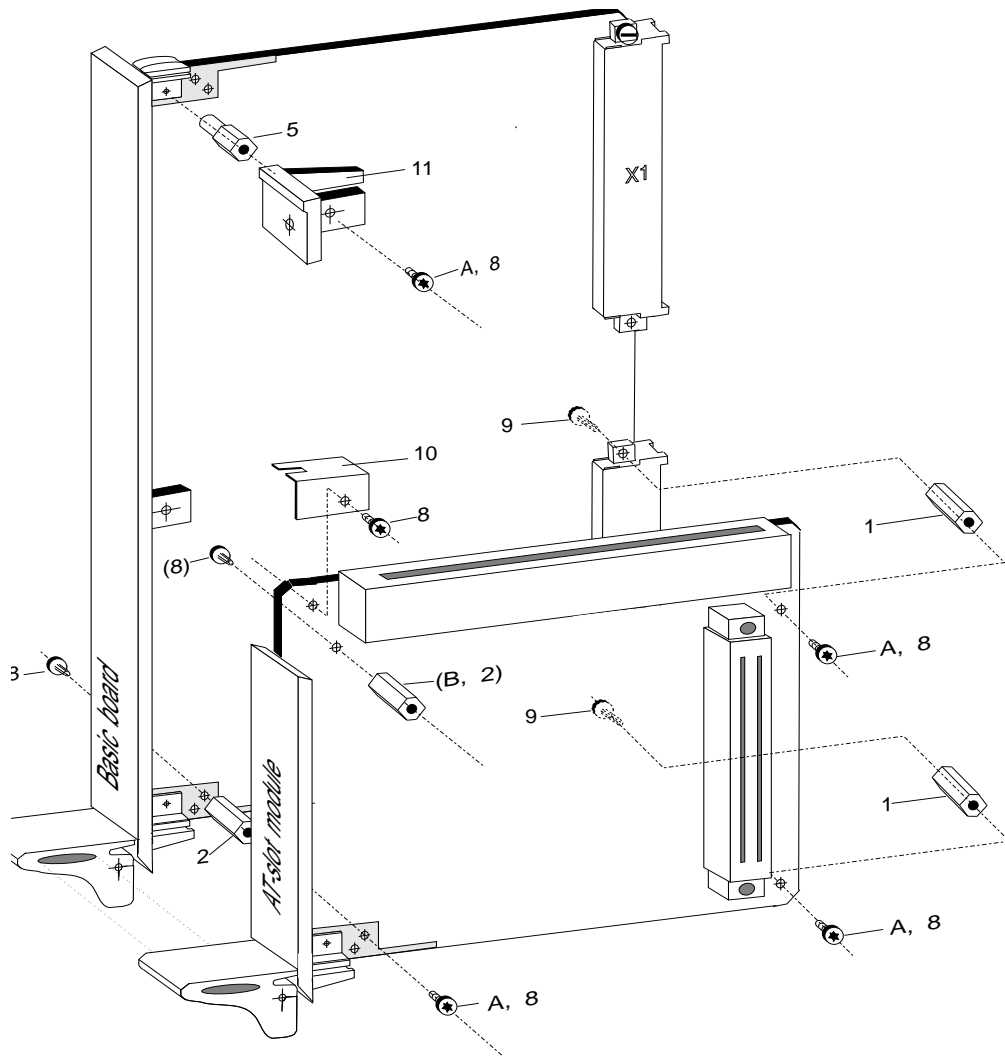

2

Fig. 2.12 Assembly of **one** AT-slot module onto the mass storage module

2.6.4.5 Assembly of two AT-slot Modules onto the Mass Storage Module

Proceed as follows according to Fig. 2.11 in order to assemble the modules:

1. If the AT-slot module has already been fitted completely:
Remove the five screws identified "A". The screws are required for the further assembly (identified "A" in Fig. 2.11).
2. Screw in the spacer bolts as in Fig. 2.11.
3. Plug the second AT-slot module onto the first AT-slot module, ensuring that the tongue on the eject lever of the second AT-slot module latches into the groove in the eject lever of the first AT-slot module (see Fig. 2.4). The plugs of the two modules must be completely connected together.
4. Screw the two AT-slot modules together as in Fig. 2.11 using the four screws identified "A".
5. Fit the first part "Front panel, top" onto the spacer bolts identified by "5" in Fig. 2.10; tighten the part using the spacer bolt "7" (Fig. 2.11). Using the fifth screw "A", subsequently fit the second part "Front panel, top" onto the spacer bolt "7" screwed in for securing the first part.

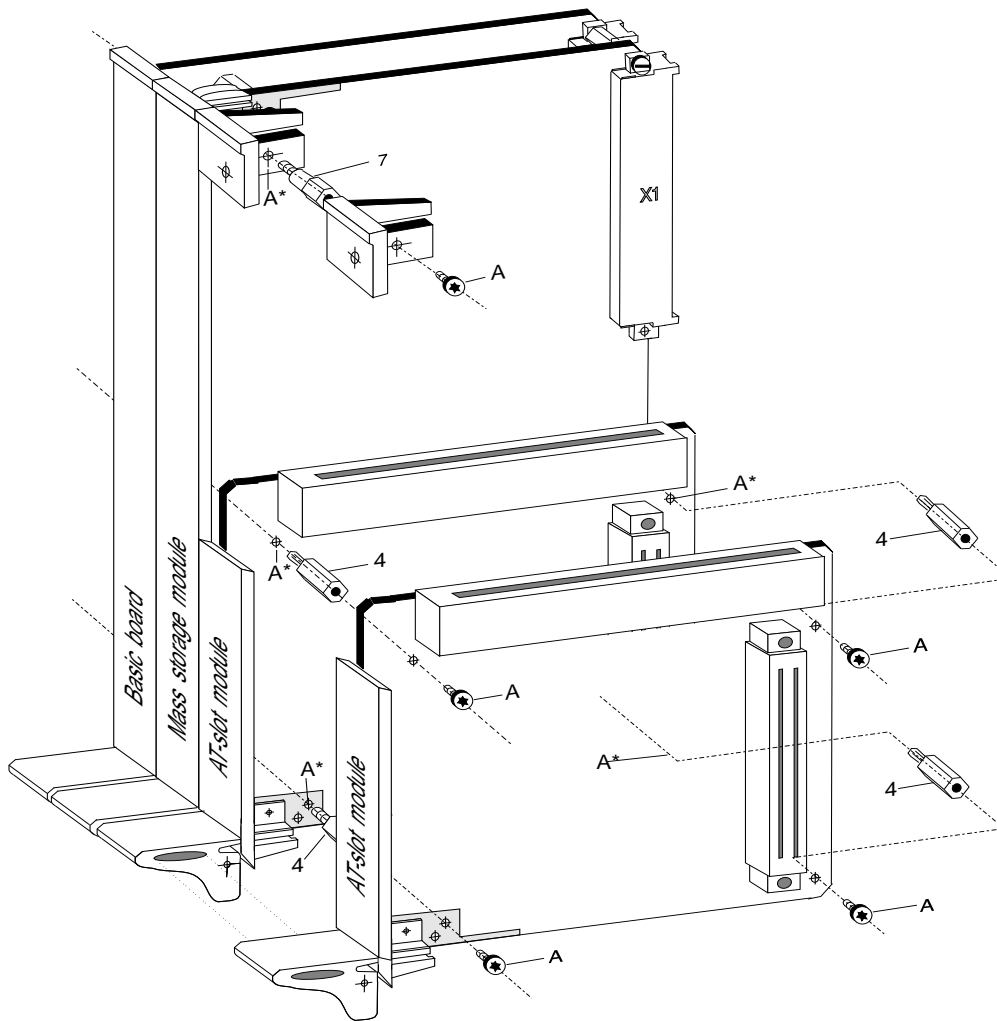

Fig. 2.13 Assembly of two AT-slot modules onto the mass storage module

2.6.5 Assembly of an AT Board onto an AT-Slot Module

You require the part Nos. 8 (screw, 6 mm long) and 12 (support) from the assembly kit C79458-L965-D12 (see Fig. 2.7) to fit an AT board onto an AT-slot module.

Proceed as follows according to Fig. 2.12 when fitting:

1. Insert the AT board from above into the female connector of the AT-slot module as shown in Fig. 2.12.
2. Insert the support "12" above the angled bracket on the AT board; the screw of the support projects into the groove of the bracket. Tighten the screw of the support.
3. As shown in Fig. 2.12, insert screw "8" through the support into part "11" which you fitted with the AT-slot module, and tighten the screw.

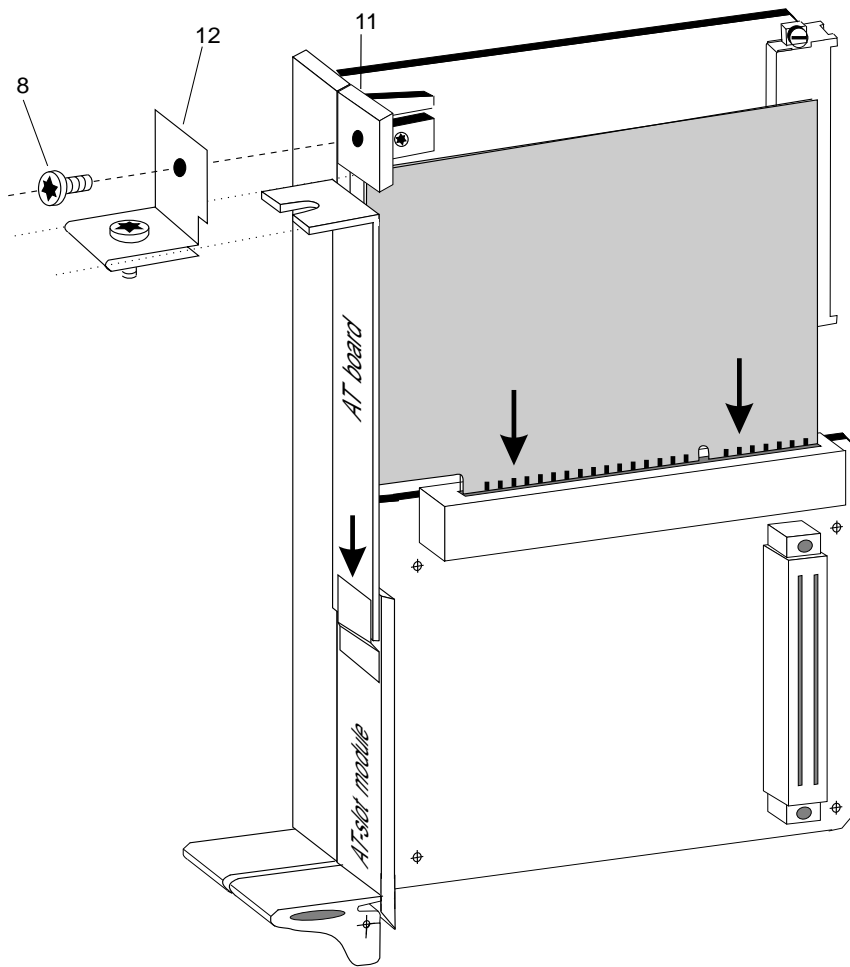

2

Fig. 2.14 Assembly of an AT board onto an AT-slot module

2.7 Installation of Complete Module into Subrack

2.7.1 Interference-free Hardware Configuration

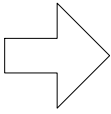
	<p>Note</p> <hr/> <p>To ensure interference-free operation, observe the shielding measures and installation guidelines included in the respective programmable controller manuals (e.g. S5-135U).</p>
---	--

Keep any interfering signals resulting from the process as far away as possible from the installation.

We assume you have observed the "SIMATIC S5 Installation Guide". The following pages summarize some of the important points of these guidelines.

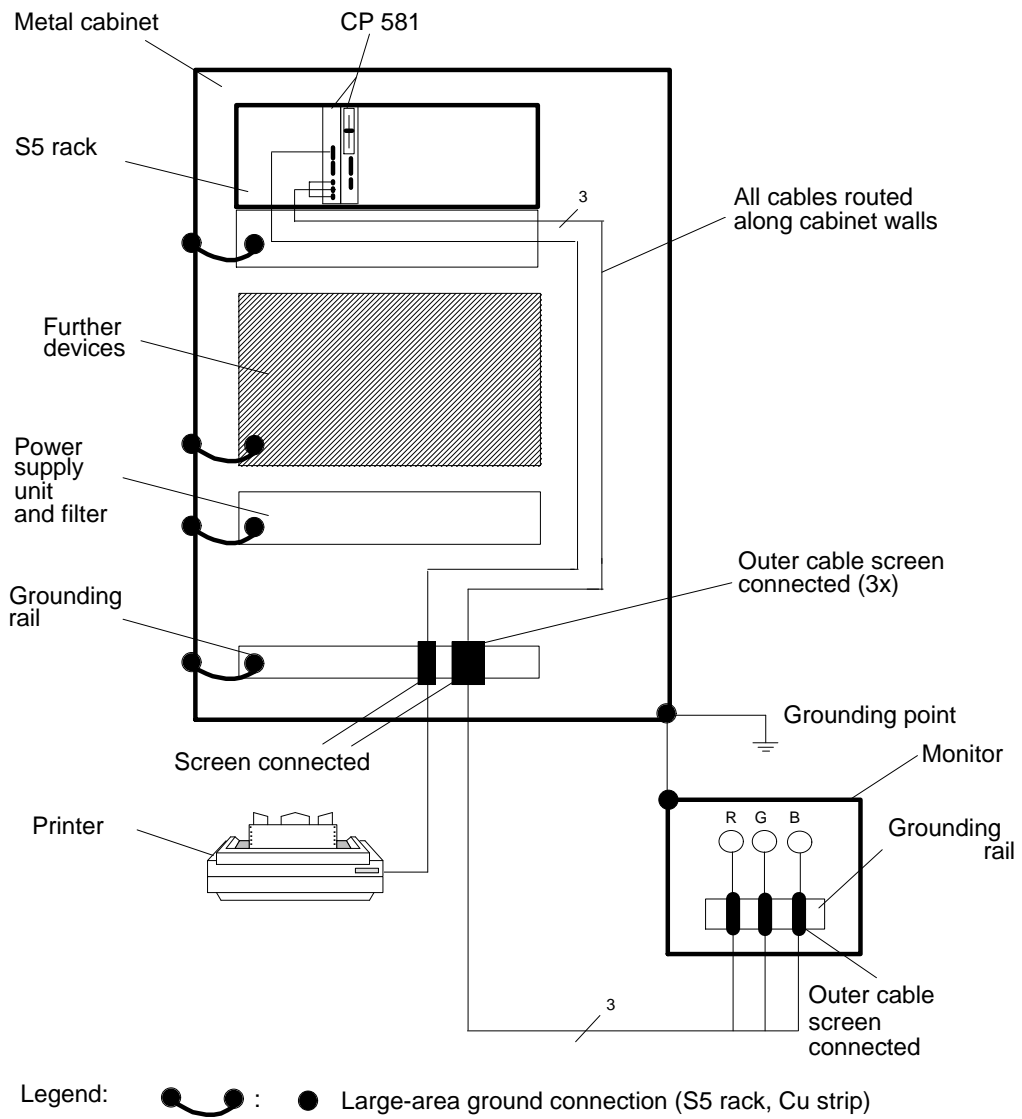

2

Fig. 2.15 Cabinet design

The following can be seen in Fig. 2.13:

- Devices which could carry noise signals from outside into the cabinet assembly should be fitted as near to the bottom of the cabinet as possible.
- Fit the grounding rails directly at the cabinet inlet so that cables carrying noise signals (e.g. monitor cables and the power supply cable for the printer) can be connected directly there. Connect all cables screened to this point (except coaxial cables with one screen). Only connect the outer screen in the case of signal cables with two screens.
- Always route signal cables along the cabinet walls.
- Route power supply and signal cables separately.
- Use separate cable racks for power and signal cables and position them at least 0.5 m apart.
- Ensure that all ground connections in the cabinet are made with a large-area contact.
- Connect doors and cabinet walls to the grounded housing support.
- Ensure when fitting a SIMATIC system in a cabinet that the cabinet is grounded.
- Relays and contactors should be interference-suppressed on site.
- Ensure that the differences in potential between various system components are as small as possible.

- In the case of systems which generate a high electrostatic voltage (e.g. textile machines, special napping machines), connect the ground lines of the machine components subject to interfering signals to a separate signal ground (large-area ground contact with building construction, armoring) which is isolated from the central grounding point of the S5 cabinet.

2.7.2 Selection of CP 581 Slots in the Programmable Controller

You can use the CP 581 in the S5-115U, S5-135U, S5-155U, S5-135U/155U and S5-155H programmable controllers.

2

- S5-115U:

Observe the following requirements for installation:

- You require an adapter casing with 2 or 4 slots (see Ordering Information, Chapter 6).
- Use a 5 V/15 A power supply.

Locations for the approved central controllers:

Central controller	Possible locations
6ES5 700-0LB11 (CR 700-0LB)	0
6ES5 700-3LA12 (CR 700-3)	0, 1, 2

- S5-135U:

Note that you cannot use the CP 581 together with the CPU 921 (S processor).

Slots for the approved central controllers (CC) 6ES5 135-....:

Slot No. CC	3	11	19	27	35	43	51	59	67	75	83	91	99	107	115	123	131	139	147	155	163	
-3KA13			■	■	■	■	■	■	■													
-3KA21			■	■	■	■	■	■	■													
-3KA31			■	■	■	■	■	■	■													
-3KA41			■	■	■	■	■	■	■													
-3UA11			■	■	■	■	■	■	■	■	■	■	■	■	■	■	■					
-3UA21			■	■	■	■	■	■	■	■	■	■	■	■	■	■	■					
-3UA31			■	■	■	■	■	■	■	■	■	■	■	■	■	■	■					
-3UA41			■	■	■	■	■	■	■	■	■	■	■	■	■	■	■					
-3UA51			■	■	■	■	■	■	■	■	■	■	■	■	■	■	■					

The PG-MUX and interrupt generation functions cannot be used at a slot occupied by a CP 581 component.

- S5-135U/155U:

Slots for the approved central controllers (CC) 6ES5 188-....:

Slot No. \ CC	3	11	19	27	35	43	51	59	67	75	83	91	99	107	115	123	131	139	147	155	163	
-3UA11			■	■	■	■	■	■	■	■	■	■	■	■	■	■	■					
-3UA21			■	■	■	■	■	■	■	■	■	■	■	■	■	■	■					
-3UA31			■	■	■	■	■	■	■	■	■	■	■	■	■	■	■					
-3UA51			■	■	■	■	■	■	■	■	■	■	■	■	■	■	■					

2

- S5-155U:

Slots for the approved central controllers (CC) 6ES5 155-....:

Slot No. \ CC	3	11	19	27	35	43	51	59	67	75	83	91	99	107	115	123	131	139	147	155	163	
-3UA11			■		■	■	■	■		■	■	■	■	■	■	■	■					
-3UA21			■		■	■	■	■		■	■	■	■	■	■	■	■					

- Expansion unit EG-185U

Slots for the approved expansion units (EU) 6ES5 185-....:

Slot No. CC	3	11	19	27	35	43	51	59	67	75	83	91	99	107	115	123	131	139	147	155	163		
-3UA11			■	■	■	■	■	■	■	■	■	■	■	■	■	■	■	■					
-3UA21			■	■	■	■	■	■	■	■	■	■	■	■	■	■	■	■	■				
-3UA31			■	■	■	■	■	■	■	■	■	■	■	■	■	■	■	■	■				
-3UA41			■	■	■	■	■	■	■	■	■	■	■	■	■	■	■	■	■				

(Each 185U expansion unit with the IM 304/314 or 307/317 interface modules)

2.7.3 Switching Off the Power Supply of the PLC Rack

	<p>Caution</p> <p>The CP 581 must not be inserted or removed with the power supply switched on. It is therefore essential for you to switch off the power supply for the PLC rack before inserting the CP 581 into the programmable controller.</p>
---	--

When switching the power supply in the CC or the EU on or off via the enable input, it is possible that write accesses to the hard disk could lead to a loss of data.

2

We recommend:

only switch the CC/EU off via the enable input when the hard disk drive is not being accessed.

2.7.4 Installation of CP 581 into PLC Rack

	<p>Caution</p> <p>When working on the system with the cabinet open, observe the general safety regulations (e.g. VDE 100) as well as the guidelines for protective measures for electrostatically sensitive devices (ESD).</p>
--	---

- Now insert the CP 581 into your PLC rack. Observe the permissible slots of the various programmable controllers (Section 2.7.2).
- Be careful to hold the module straight and not to bend the contact springs of the guides in the subrack.
- Lock the CP 581 in the subrack.

2.8 Connection of Operation Devices and Peripheral Devices

The connections for the operation devices and peripheral devices are on the front panel of the basic board and mass storage module. Figs. 2.1 and 2.2 show which devices can be connected, and where.

You can find comprehensive information on **all** connection possibilities of the CP 581 in the corresponding sections in the Reference Section for Hardware.

A keyboard and monitor are required to use the CP 581. You can additionally connect a logging printer and a mouse.

When connecting the peripheral devices, we recommend that you use the standard cable connectors provided by Siemens for reasons of interference resistance within the complete system.

You require the Y adapters listed in Chapter 6, Ordering Information, in order to use the standard cable connectors.

2



Caution

Important note when routing connection cables for peripheral devices:

Monitor cables and connection cables between the CP 581 and the keyboard/printer/mouse must not be routed parallel to power cables!

Route them on their own cable rack positioned at least 50 cm away from the power cables.

2.8.1 Connection of Keyboard

We recommend the use of a *PG 750 keyboard*.

- ***Connection via the Y adapter Keyboard/COM 2***

Connect the keyboard to the 7-way round socket of the Y adapter.

- ***Connection via the remote terminal interface***

Connect the keyboard to the 7-way round socket X2 of the RTI module.

2.8.2 Connection of Monitor

Connect the monitor to the CP 581 basic board via the VIDEO (RGB) interface.

Note the following points:

- You must only use double-screened coaxial cables (triax cables) if the environment is not conducive to EMC (see Chapter 6, Ordering Information). You can use these cables up to a length of 250 m without further measures.
- When using triax cables, only connect the outer screen of the monitor cable to the housing potential of the process monitor (see Fig. 2.14).
- Make large-area metal-metal connections.
- Isolate the electronics ground of the monitor (see Fig. 2.14) from the housing ground. The separation has already been made in the Siemens multistandard color monitor 6AV1414-0AA00 listed in Chapter 6.
- Connect the monitor and the programmable controller to the same phase.
- Different ground potentials between the rack and the monitor housing may lead to picture hum (horizontal dark bars). For this reason and for protection against accidental contact, connect an equipotential bonding conductor between the S5 cabinet and the monitor housing. The equipotential bonding conductor must be dimensioned by carrying out measurements on the system such that a difference in potential of 200 mV is not exceeded.

2

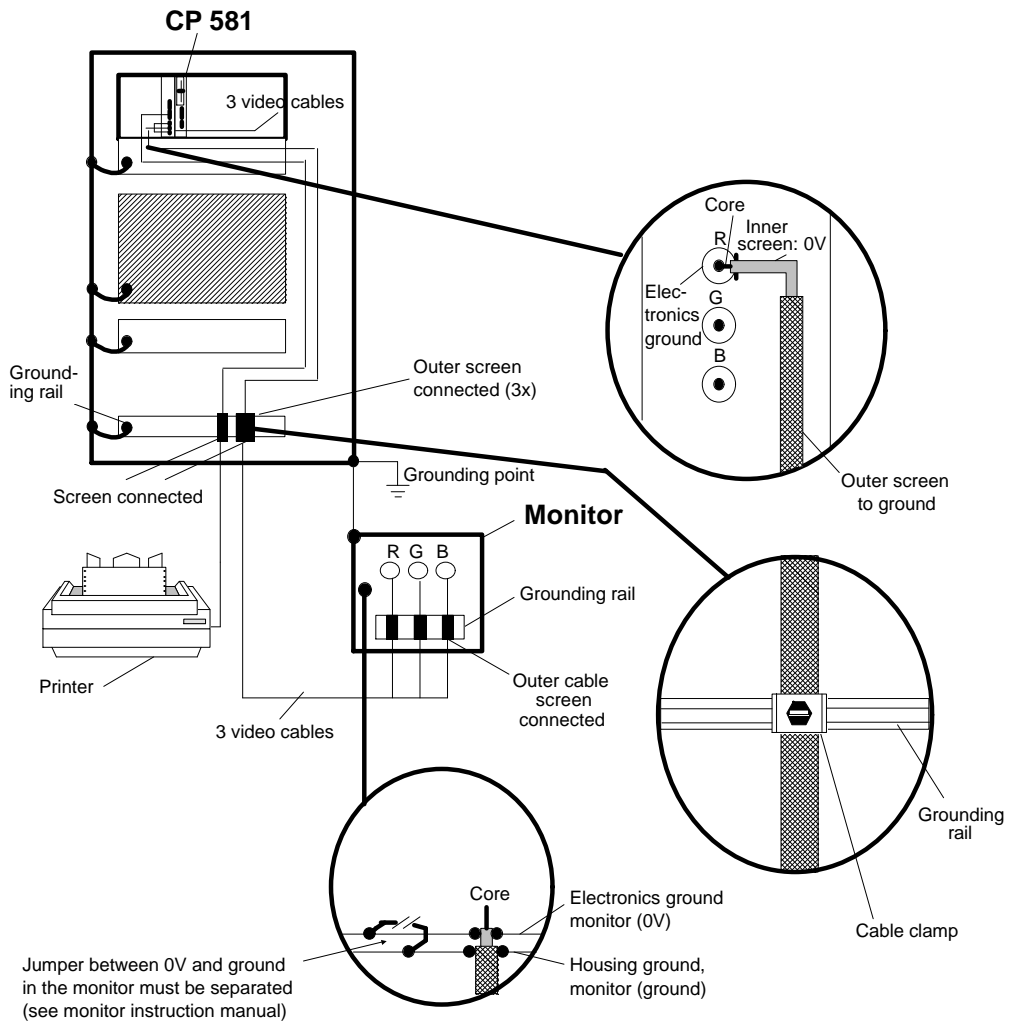

Fig. 2.16 Cable connection to grounding rails

Information on positioning of monitors

- When positioning monitors ensure that the distance between two monitors in the case of asynchronous operation is at least 15 cm since picture interferences could otherwise occur.
Exception: monitors with mu-metal screening
- The monitor and external magnetic sources should be sufficiently far apart.
- Do not place the monitors in steel racks or on steel desks. Magnetization of the surrounding sheet-steel panels may lead to color or picture distortions.
- Do not install monitors in the vicinity of transformers, walkie-talkies, loudspeaker magnets and power cables.
- External magnetic fields can be suppressed by using mu-metal screening.

2

Special conditions when using office monitors

- You must not use office monitors with a plastic housing metal-coated on the inside in environments not conducive to EMC since the internal metal surface cannot be connected to the external grounding rail at a later date. The separation between the electronics ground and the housing ground of the monitors which is essential for environmental conditions not conducive to EMC is not possible with most office monitors.
- You can only use such office monitors together with single-screened coaxial cables. Connection to the CP 581 is thus only possible to a limited extent since only short distances can be covered using these cables.

2.8.3 Connection of a Printer

- Connect a printer with serial interface to COM 1/3 (basic board) or COM 4 (mass storage module) using the corresponding Y adapter (see Chapter 6, Ordering Information).
Connect a printer with parallel interface to LPT (mass storage module).
- We recommend the use of Siemens printers.
Further information on these printers such as the technical data and order nos. for accessories (printer cables, interfaces etc.) can be found in Sections 3.1.4, 3.2.6 and 3.2.7 in the Reference Section for Hardware and in Chapter 6, Ordering Information.



Note

Only cables with the screen grounded at both ends may be used between the CP 581 and printers.
Note that the MS-DOS command PRINT cannot be used with the TTY interface.

2.8.4 Connection of a Mouse

The CP 581 software supplies does not use a mouse!

It may be useful to connect a mouse in order to use additional software on the CP 581.

Connect the mouse to the CP 581 in the following manner:

- **Connection via the Y adapter Keyboard/COM 2**

Connect the mouse to the 9-pin D-subminiature plug of the Y adapter.
You can also connect a PG 750 mouse to the mouse plug fitted on the side of the PG 750 keyboard.

Note when connecting the mouse to the PG 750 keyboard that the COM 2 interface is also occupied.

2

- **Connection via the remote terminal interface**

Connect the mouse to the 9-pin D-subminiature plug X3 of the RTI module.
The mouse cannot be connected to the PG 750 keyboard when using the RTI!

2.8.5 Connection of a Light Pen

Connect the light pen to the CP 581/486 in the following manner:

- **Connection via the Y adapter Keyboard/COM 2**

Connect the light pen to the 9-pin D-subminiature plug of the Y adapter. Note that the jumper X60 on the basic board of the CP 581/486 must be plugged on 2-3 for the light pen.

- **Connection via the remote terminal interface**

Connect the light pen to the 9-pin D-subminiature plug X3 of the RTI module.

2.8.6 Maximum Cable Lengths for Connection of Operation Devices and Peripheral Devices

The following table lists the limits for the cable lengths between the devices. A prerequisite is an interference-resistant hardware design as described in Section 2.7.1.

Table 2.1 Maximum cable lengths for operation devices and peripheral devices

Device	Length Configuration 1 (local)	Length Configuration 2 (remote)
Printer with V.24 interface	20 m	-
Printer with TTY interface	-	500 m
Printer with parallel interface	3 m	-
Monitor (when using triax cables)	250 m	250 m
Mouse	1.5 m	250 m (with RTI)
PG 750 keyboard	1.5 m	250 m (with RTI)
Light pen	1.5 m	250 m (with RTI)

2.9 Commissioning

Set the RUN/STOP switch to "RUN".

Checklist before switching on the power supply

Before you switch on the power supply, check using the following list that all preparations have been made:

- Have you considered the environmental conditions for the CP 581 and connected peripheral devices?
- Is the CP 581 inserted into an approved slot in the subrack?
- Are the peripheral devices connected correctly?
- Have you connected all the cable screens correctly?
- Have you installed the monitor correctly and considered the electromagnetic environmental conditions?
- Have you observed the S5 installation guidelines for programmable controllers?

2

Switching on peripheral devices

Now switch on the monitor and printer.

Switching on the power supply to the PLC rack

Now switch on the power supply to the programmable controller rack. The following processes are then executed on the CP 581 or the connected peripheral units:

- The CP 581 runs up.
- The LEDs on the NUM LOCK and SCROLL LOCK keys light up briefly on the connected PG 750 keyboard.
- The following message appears on the screen:

386SL Modular BIOS Vx.xx... or 486SL Modular BIOS Vx.xx...

- The STOP and FAULT LEDs light up until you have made a correct SETUP (see Section 2.10).
- The operation display on the hard disk drive on the mass storage module now lights up every time it is accessed.

Hardware commissioning of the CP 581 is now finished.

If you wish to install and commission the software, read further in Section 2.10 "Installation and Commissioning of the Software".

2.10 Installation and Commissioning of Software



Note

You can find the current delivery stage of the CP 580/CP 581 system software in the DIR.TXT file.

Please note that you require the mass storage module or the CPLINK program for initial commissioning.

The CP 581 in the design with a basic board and mass storage module runs up with the preset SETUP parameters. You must still set the hardware clock in the SETUP during initial commissioning, however.

2

2.10.1 Installation with Mass Storage Module

You have received the MS-DOS operating system and the CP 581 system software on floppy disks. You must install both software packages onto the hard disk. Proceed as follows:

1. Install MS-DOS on the hard disk.
2. Make back-up copies of the MS-DOS and CP 581 disks.
3. Install the CP 581 system software on the hard disk.

Installation of MS-DOS

Refer to your MS-DOS manual on how to install MS-DOS.



Note for CP 581

Driver **EMM386.EXE**: If you select the function "Upper memory blocks", you must enter the option "**X=CC00-DFFF**" (dual-port RAM and flash page) or "**X=CC00-CFFF**" if you do not use a silicon disk. With a CP 581/486SL enter the option "**X=CC00-CFFF**".

Driver **HIMEM.SYS**: If you wish to use this driver, you must enter the option **"/m:2"** when loading the driver.

Making back-up floppy disks

Use the MS-DOS command **DISKCOPY** to make back-up disks. This function physically copies a source disk onto the target disk. The back-up disks need therefore not be formatted. They must be the same type as the supplied disks, however, i.e. 3.5" HD disks.

Since the CP 581 only has **one** floppy disk drive, you must enter the same drive name for the source and target in the start command for DISKCOPY.

Proceed as follows:

- Start the function using the command **C:DISKCOPY A: A:**
- DISKCOPY requests you to alternately insert the source and target disks into the drive.
- Insert the requested disk into the drive, close the drive and acknowledge the request by pressing any key.
- Carry out the operations for every supplied disk until all disks have been copied.

Installing the CP 581 system software

Insert the supplied disk with the CP 581 system software into the drive and enter command

A:INSTALL C:

When you install the system software (using the INSTALL command), ensure that you choose the correct destination CP (CP 580, CP 581 with -386 or CP 581/486). The INSTALL program now copies the CP 581 system software from the floppy disk onto the hard disk. INSTALL will inform you on the screen of any operations you need to make.

Setting the hardware clock of the CP 581 in the SETUP

You can activate the SETUP program in the following manners:

- Carry out a warm restart by entering the following key combination:

CTRL and **ALT** and **DEL**

- As soon as the message

"386SL Modular BIOS Vx.xx . . ." or **"486SL Modular BIOS Vx.xx . . ."**

appears, press the keys

CTRL and **ALT** and **ESC**

2

The SETUP form appears on the screen following activation of the SETUP program. Select an input field using the **cursor keys** and carry out settings or select options in this field using the **"+/-" keys**.

Set the date and time and then press key F10. Then press key F5 to save your settings.

MS-DOS functions



Caution

Ensure that no data traffic is present on the S5 bus when you use the MS-DOS command FORMAT. The commands PRINT and COPY prevent communication with CPMASS and CPRECORD and should therefore be used with caution.



Caution

Do not use a write cache with the CP 580/CP 581 system software as you can with SMARTDrive in Windows version 3.1.

Initial CP 581 start-up

The AUTOEXEC.BAT file is optionally initialized by INSTALL such that the CPDHB driver, the mass storage functions and the command interpreter are available when the CP has been run up correctly.

The RUN, STOP and FAULT displays are set by the CPDHB driver according to the current operating state when the driver is called.

The RUN display only lights up if the RUN/STOP switch is set to RUN and at least one page is synchronized.

Activation of supplied applications

To activate and test CPRECORD, CPMASS, CPSHELL and S5REMOTE/S5REMOTF, please read the following sections in Volume 2/2 of the manual:

- "Process data acquisition" (CPRECORD),
- "Mass storage functions" (CPMASS),
- "Command interpreter" (CPSHELL) and
- "Virtual S5 drive" (S5REMOTE).

Normal restart of CP 581

A normal restart is always carried out when you switch off the operating voltage to your PLC and then on again, if the CP 581 is ready, and if the device configuration preset in the software has been retained in the RAM as a result of the battery back-up.

Activation of serial interface for the printer

Remove the comment identification "REM" from the line in the AUTOEXEC.BAT file with the entry

"REM MODE LPT1:=COM1".

2

Note



The installation of the system software for the CP 581 with a basic board and mass storage module has now been completed. Refer to the following Section 2.10.2 for the operations you must carry out for individual operation of a basic board. Section 3.7 provides you with a summary of all possible SETUP settings.

2.10.2 SETUP for Individual Operation of the CP 581 Basic Board with Silicon Disk

You can operate a CP 581 basic board with silicon disk even without a mass storage module. The MS-DOS operating system can be booted both from the onboard silicon disk or also from the memory card. These two storage media are addressed by the user program like conventional drives.

The logical drive numbers when operating the basic board without a mass storage module are then as follows:

Drive designation	Data medium
A:	Memory card of basic board
C:	Onboard silicon disk of basic board



Note

You can increase the data volume which can be stored on the silicon disk by using a compression program. You must then decompress the compressed files on a RAM disk when running up the CP 581.

Refer to Section 2.10.1 on how to reach the SETUP form.

The following form then appears on the screen:

Date: 09 June 1992	*) 80x86SL ISA BIOS SIEMENS SIMATIC CP 581 VERSION x.x
Time: 00:00:00	
Drive A: 1.44 M, 3 1/2 in.	Base Memory: 640k Extended Memory: 3072k Expanded Memory: 0k Other Memory: 384k ----- Total Memory: 4096k
Drive B: None	
Video: EGA/VGA	Security: Disable
Post Messages: Maximize	
Quick Boot: Disable	
Halt On: No Errors	
Boot Sequence A,C	
Auto Detect IDE Drive C:	

		CYLS.	HEADS	SECTORS	PRECOMP	LANDZONE
Drive C: IDE (116 MB **)		762	8	39	None	761
Drive D: None (0 MB)		0	0	0	0	0

Alt-F1 for Menu Help	PgDn = S5 Page	F10 exits
Page 01: Status Page		F2 change colors

2

*) CP 581 : x = 3 CP 581/486 : x = 4 **) with a 60-Mbyte hard disk: 823/4/38/None/822

Fig. 2.17 SETUP menu

When operating the CP 581 without a mass storage module, **no conventional** drives must be specified in the SETUP menu. Enter the data for the floppy disk drive (drive A:) and the hard disk drive (drive C:) as in Fig. 2.17.

The drive to be used for booting is selected in the field "**Boot Sequence**". You have the following possibilities:

- Enter "A,C" to boot from the memory card.
- Enter "C,A" to boot from the onboard silicon disk.

Booting from memory card or onboard silicon disk

You must first format the storage medium from which you wish to boot. The necessary operations differ depending on the configuration of your system.

Initial status: basic board and mass storage module present

- Initializing a bootable memory card:

	<p>Note</p> <hr/> <p>When running up the CP 581, the memory card which is to be formatted or another card of the same type must be inserted.</p>
---	---

- If not already done: enter the memory card in the SETUP as "Drive B:" and reboot from the mass storage module.

- Format the memory card using the MS-DOS command **FORMAT**:

FORMAT B: /U /S

- Transfer the software which you require (MS-DOS, system software for CP 581 etc.) onto the memory card.

- Delete the floppy disk drive and hard disk of the mass storage module in the SETUP (fields "Drive A:" and "Drive C:") as well as the memory card as "Drive B:", and subsequently reenter the memory card as "Drive A". Then enter "A,C" for "Boot Sequence".
- Carry out a warm restart: booting is now carried out from the memory card. You can now remove the mass storage module.
- Initializing a bootable onboard silicon disk:
 - Generate a bootable system floppy (FORMAT command with option "/S") or memory card (see previous page) according to the SETUP entry "Drive A".
 - Copy the MS-DOS programs FORMAT and FDISK onto the floppy disk or memory card.
 - If not already done: enter the onboard silicon disk in the SETUP as "Drive D:" and subsequently reboot the operating system.
 - Initialize a "Primary DOS partition" on the onboard silicon disk using the MS-DOS command **FDISK**:
 - A menu with 5 possible selections appears following input of the command FDISK. "1" appears as the current hard disk above the menu; this is the hard disk of the mass storage module.
 - First change the current hard disk: select the option "5" from the menu (enter number and press Return key) and enter "2" as the current hard disk (onboard silicon disk). Subsequently return to the main menu and press the ESC key.
 - Select the option "1".
 - A submenu appears with 3 possible selections. Select the default setting (option "1") by pressing the Return key.

- Answer the following question "Should the maximum available" with "Y".
- Press the ESC key twice in order to leave FDISK. The operating system is subsequently rebooted.
- Format the onboard silicon disk using the **FORMAT** command:

FORMAT D: /U /S

- Transfer the software which you require (MS-DOS, system software for CP 581 etc.) onto the onboard silicon disk.
- Delete the hard disk of the mass storage module (field "Drive C:") and the onboard silicon disk (field "Drive D:") in the SETUP, and subsequently enter the onboard silicon disk as "Drive C". Then enter "A,C" for "Boot Sequence".
- Boot the operating system again from the floppy disk or memory card.
- Now activate the previously initialized partition on the onboard silicon disk using the **FDISK** command:
 - Select the function "2" (enter number and press Return key) in the FDISK menu.
 - Enter "1" as the active partition (enter number and press Return key).
 - Press the ESC key twice to leave FDISK.
- Now enter "C,A" for "Boot Sequence" in the SETUP.
- Carry out a warm restart: booting is now carried out from the onboard silicon disk. You can now remove the mass storage module.

Initial status: only basic board without mass storage module present

- Initializing a bootable memory card:

In order to be able to generate a bootable memory card without mass storage module, the onboard silicon disk of the basic board used for this must be initialized and formatted.

The memory cards cannot be formatted or initialized for booting if neither a basic board prepared in this manner nor a mass storage module is present. Exception: when using CPLINK.

If the onboard silicon disk of the basic board used is initialized and formatted, you can proceed as when creating a bootable memory card with mass storage module. Use the onboard silicon disk instead of the hard disk, and enter the memory card as "Drive A:" in the SETUP. Enter "A:" as the drive in the FORMAT command.

2

- Initializing a bootable onboard silicon disk:

The onboard silicon disk cannot be formatted or initialized for booting if neither a bootable memory card with the MS-DOS programs FDISK and FORMAT nor a mass storage module is present. Exception: when using CPLINK.

- Insert a bootable memory card with the MS-DOS programs FORMAT and FDISK.
- If not already done: enter the onboard silicon disk in the SETUP as "Drive C:" and reboot from the memory card.
- Initialize a "Primary DOS partition" on the onboard silicon disk using the MS-DOS command **FDISK**:
 - A menu with 4 possible selections appears following input of the command FDISK. Select option "1" (default setting) by pressing the Return key.

- A submenu appears with 3 possible selections. Select the default setting (option "1") by pressing the Return key.
- Answer the following question "Should the maximum available?" with "Y".
- Press the ESC key twice in order to leave FDISK.
- The operating system is subsequently rebooted.
- Format the onboard silicon disk using the **FORMAT** command:

FORMAT C: /U /S

- Transfer the software which you require (MS-DOS, system software for CP 581 etc.) onto the onboard silicon disk.
- Now enter "C,A" for "Boot Sequence" in the SETUP.
- Carry out a warm restart: booting is now carried out from the onboard silicon disk.

Note



The flash EPROMs are deleted when formatting or overwriting the memory card and onboard silicon disk. The number of delete operations is currently limited to approx. 10000 as a result of the physical characteristics of the flash EPROMs.

2.11 CPLINK

Startup Program for a CP 581 without Mass Storage Module using a PG/PC

2.11.1 Use, Functions and Structure of CPLINK

Characteristics and purpose of CPLINK

CPLINK is a software package whose use enables the silicon disk or memory card of a CP 581 to be accessed by a PG/PC in remote mode.

The block-oriented device-driver CPLINK.EXE generates two additional drives in the PG, where the first drive addresses the Onboard Silicon Disk and the second drive addresses the memory card, in each case like a standard MS-DOS drive.

2

The physical connection is made via the COM1 serial interface of the CP 581.

The COM interface on the PG and the data transmission rate can be set between 9.6 kbps and 115.2 kbps.

The remote partner automatically recognizes the baud rate set on the PG when configuring CPLINK.

The REMSETUP.EXE program enables additional access via the serial interface to the SETUP stored in the BIOS of the module (prerequisite: CPLINK is installed).

Device drivers

The CPLINK functions are implemented by one driver in the BIOS (EPROM) of the CP 581 (remote) and another in the PG (local). The block device driver CPLINK.EXE is designed such that it can be addressed by MS-DOS using logical sector numbers. The CPLINK drivers provide the file system of MS-DOS (≥ 5.0) with an additional access function to the remote drives (subsequent identification on PG drives, e.g. d:, e: or e:, f:).

Data transfer

The file sectors passed on to the MS-DOS device driver are transmitted to or from the storage media on the remote module via the V.24 interface (see Fig.). An interface for logical sector numbers is implemented in the silicon disk driver of the module in order to handle the data transfer (SW interrupt 60 h).

A declared character sequence is sent to the remote module during the initialization following loading of the driver into the system memory. The module recognizes the set baud rate from the signal. Once this has been recognized, the module sends an acknowledgement character, and the message "LINK established (COM?, ? bps)" appears on the screen.

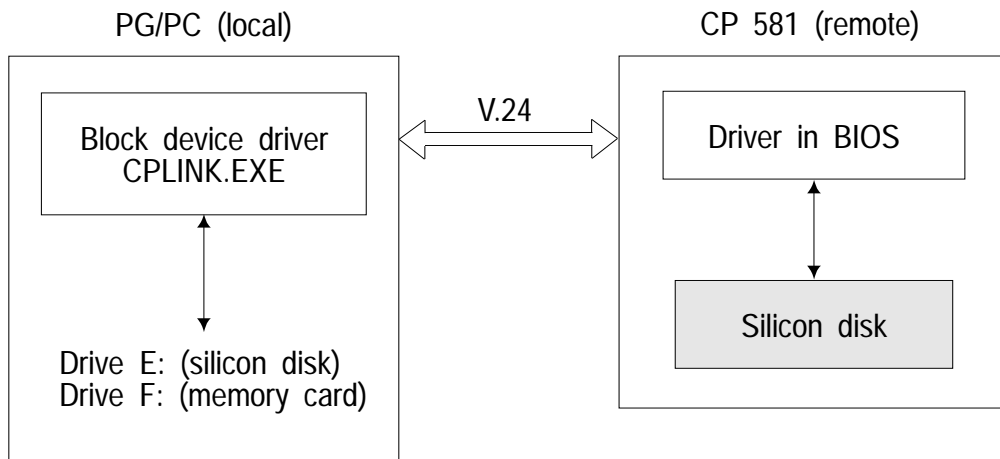
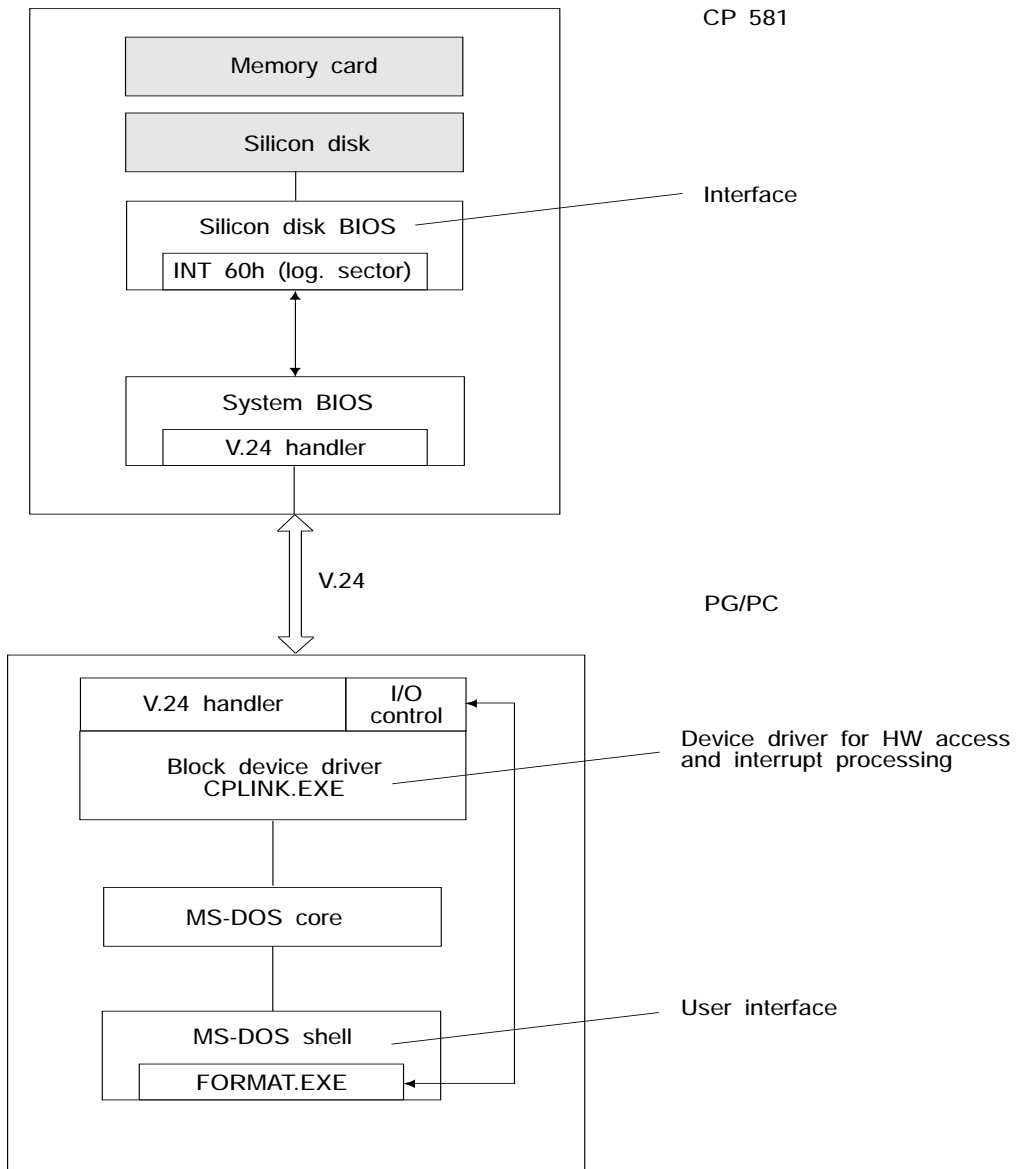

Fig. 2.18 Data transfer

CPLINK structure

The V.24 handler in the two devices results in the serial transmission and reception of commands and data blocks. A generic I/O control interface is installed in the device driver to enable memory formatting using the standard MS-DOS command FORMAT.



2

Fig. 2.19 CPLINK structure

2.11.2 Installation of CPLINK

Area of use

CPLINK is implemented by a driver in the BIOS in the CP 581 (remote) and a block device driver CPLINK.EXE in the PG/PC (local). CPLINK.EXE can also be called as an EXE file. Prerequisites are MS-DOS \geq 5.0, a system BIOS (with CP 581 version 2.0 or later) and a flash BIOS (version 2.0 or later) in the PG/PC.

CPLINK enables remote computer modules such as the CP 581 to be loaded and started using the PG.

When delivered in the basic version (without mass storage module), these devices are "empty", i.e. neither an operating system nor the CP software is loaded. CPLINK handles the task of installing the software onto the silicon disk or memory card of the remote module in a simple manner.

Delivery: Floppy disk
File: CPLINK.EXE
Name/call: "CPLINK"

Caution!

You can only install CPLINK when the CP switch is in the STOP position.

Loading of driver CPLINK.EXE

1. Copy the file "CPLINK.EXE" from the floppy disk onto the hard disk of your PG/PC, e.g. into the root directory.
2. Call the file C:\CONFIG.SYS using the MS-DOS editor "EDIT".
3. Install the device driver using the entry:
DEVICE=CPLINK.EXE [c][b] or
DEVICEHIGH=CPLINK.EXE [c][b].

Refer to the table overleaf for the options [].

4. Leave the editor using <ESC>.
5. Carry out a cold or warm restart on your PG.

The driver is loaded by DOS in the process, and the following message is output:

```
CPLINK Driver V ?, ?, Copyright 1993 Siemens AG
CPLINK Drives ? and ? installed.
Waiting for handshake from remote driver.
LINK established (COM?, ???bps).
```

CPLINK waits 10 s for the handshake from the remote driver. Without a reaction, CPLINK aborts with the error message "Remote V24 Comm Error". In this case, the baud rate of the remote driver can be set later during initialization using the command "CPLINK /i".

The operating system now provides two additional drives whose designations depend on the number of PG drives. The corresponding designations are appended in each case, e.g. if the drives a: to d: are present or defined, "e:" is used for the onboard silicon disk and "f:" for the memory card.

2

Installation options

When entering the device driver into the CONFIG.SYS file, you must specify the interface used on the CP 581 and the desired baud rate in the form of options if your installation does not correspond to the default values [c] = 1 and [b] = 1.

Examples:

```
DEVICE=CPLINK.EXE 1 1      Connection via COM1 with 115200 bps
DEVICEHIGH=CPLINK.EXE 2 4  Connection via COM2 with 9600 bps
```

The following table shows the possible settings for the interface (COM) and the data transmission rate (baud rate). At larger distances, operation is more reliable the smaller you select the baud rate.

Table 2.2 CPLINK: settings for the COM interface

Option [c]	Interface on the local station	Option [b]	Transmission rate (baud)
1 *	COM1	1 *	115 200 bps
2	COM2	2	38 400 bps
3	COM3	3	19 200 bps
4	COM4	4	9 600 bps

Subsequent initialization

The following text appears when calling CPLINK without one of the options /s, /i, /r or /a

```

CPLINK V ?., Copyright 1993 Siemens AG
Syntax device-driver: device=cplink.exe <c> <b>
<c> : 1=COM1, 2=COM2, 3=COM3, 4=COM4
<b> : 1=115,2Kbps, 2=38,4Kbps, 3=19,2Kbps, 4=9,6Kbps
Syntax exe-file: CPLINK <option>
/s : Display status of device driver
/i : Initialize local and remote driver
/a : Abort remote driver (=> remote boot)
/r : Reset remote driver (=> waiting for handshake)

```

When calling "CPLINK /s", the designations (letters) of the installed drives are displayed:

CPLINK Device driver installed as drive?: and ?:

By calling "CPLINK /i" you initialize the drivers in the remote station and in the remote station.

The V.24 interface in the local station (PG/PC) is reset in the process, and a character sequence sent to the partner station for identification of the baud rate.

The remote station sends an acknowledgement character when it has recognized the current baud rate. The following message appears on the PG:

Initializing local and remote driver - successful.

If the RUN/STOP switch on the remote station is set to STOP, the V.24 connection is established prior to booting of the station, and the baud rate determined. The following message appears on the screen as soon as the baud rate has been determined:

2

**CPLINK V ?., Copyright 1993 Siemens AG
Waiting for handshake at COM1 (press any key to quit)
LINK established (???bps)**

If you wish to clear the V.24 connection and to boot the remote station, press any key on the CP 581 or set the RUN/STOP switch to RUN.

Renewed start of driver in remote station

The call "CPLINK /r" triggers a warm restart of the remote station and restarts the CPLINK driver. The local driver CPLINK.EXE, for example, can then be reinstalled with a different baud rate.

The following message appears on the screen of the PG/PC:

Resetting remote driver - Done.

Aborting the data connection

The call "CPLINK /a" aborts processing of the device driver in the remote station (CP 581).

The system BIOS of the remote station is then continued and booted. The following message appears on the PG/PC:

Aborting remote driver - Done.

2.11.3 PG Functions on Basis of CPLINK

Formatting of silicon disk or memory card

The standard DOS command FORMAT creates sectors on the memory medium, in this case the silicon disk or memory card. The root directory and the file allocation table (FAT) are created at the same time.

Always use the FORMAT instruction together with the option "/u". Formatting of the memory medium is then carried out unconditionally.

A boot sector is also created if you inform FORMAT by means of the option "/s" to carry out a system transmission (MS-DOS) simultaneously with the formatting. It is then possible to boot the CP 581 from one of the memories on the basic module.

2

The following specification of the FORMAT instruction results in formatting of the silicon disk including creation of a partition table and copying of the system files (in this case the PG possesses four real/logical drives):

FORMAT e: /u /s

Adaptation of setup and installation of CP system software

The programs SETUP386.EXE (for the CP 581¹⁾) and SETUP486.EXE (for the CP 581/486¹⁾) enable a BIOS setup of the remote station via CPLINK.

These programs first transfer the contents of the CMOS-RAM of the remote station to the PG/PC.

You can then edit these data in the setup menu and subsequently return them to the remote station; key sequence: "F10, F5". The key sequence "F10, F5" triggers a warm restart of the remote station.

¹⁾ Note: The program SETUP386.EXE is for the 386 BIOS version ≥ 2.0 .
The program SETUP486.EXE is for the 486 BIOS version ≥ 1.0 .

The following must be entered in the setup screen form for CP 581:

Drive A: = flash card or RAM card

Drive C: = OSD (Onboard Silicon Disk)

You can abort the procedure without data transmission using the key sequence "F10, F1".

The BIOS setup menu corresponds to the menu installed in the BIOS EPROM and is described in Section 3.7.

Load the MS-DOS system using "FORMAT e: /s".

Load the software specific to the CP 581 using "install e:".

Loading of user software

```
copy *.* e:\  
copy autoexec.bat e:\  
copy config.sys e:\
```

2.11.4 Technical Information

2.11.4.1 Establishing/clearing the Connection

The RUN/STOP switch is scanned in the BIOS of the CP 581 prior to booting. The V.24 connection is established if the switch is set to STOP, otherwise booting is carried out.

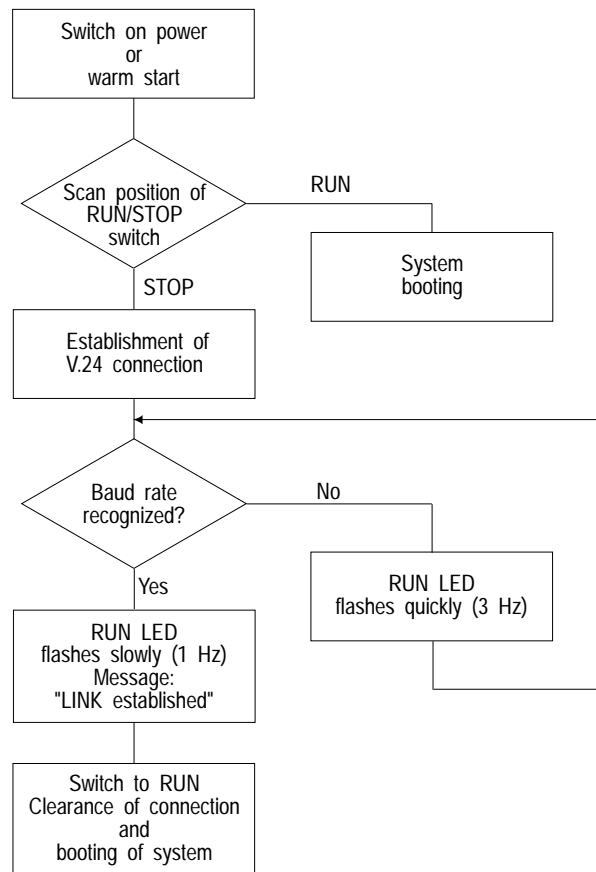

Fig. 2.20 Establishing/clearing the connection in the course of booting

2.11.4.2 Limitations with DOS Functions

The following drive-based DOS functions cannot be used in the case of remote handling with CPLINK:

Table 2.3 Illegal DOS functions with remote handling

DOS function	Task / effect
FASTOPEN	Stores directories in the system memory
FDISK	Create new hard disk

2

Error handling

The V.24 data transmission is timeout monitored and subjected to a cyclic redundancy check.

Abbreviations used

BIOS	Basic input output system
bps	Bits per second
GND	Ground (chassis, screen or plug housing)
OSD	Onboard silicon disk
RxD	Received data
TxD	Transmitted data
V.24	Transmission standard: serial, asynchronous

2.11.4.3 Further Reading

- MS-DOS Programming Manual, Ray Duncan (editor)
- Writing DOS Device Drivers in C, P.M. Adams

Reference Section for Hardware

3

Contents of Chapter 3

3

3.1	Basic Board	3 - 6
3.1.1	Mechanical Construction	3 - 6
3.1.2	Controls and Displays	3 - 10
3.1.3	Switch and Jumper Settings	3 - 13
3.1.4	Connection of Printers	3 - 17
3.1.5	Connection of Keyboard	3 - 18
3.1.6	Connection of a Mouse	3 - 18
3.1.7	Connection of a Light Pen	3 - 19
3.1.8	Connection of a Monitor	3 - 19
3.1.9	External Interface Assignments	3 - 19
3.1.9.1	Combined Plug X6 for the Serial Interfaces COM 1 and COM 3	3 - 20
3.1.9.2	Combined Plug X7 for the Keyboard and Serial Interface COM 2 (Mouse)	3 - 22
3.1.9.3	Plug X15 for a Memory Card	3 - 23
3.1.9.4	Video Outputs	3 - 27

3.1.10	Internal Interface Assignments	3 - 28
3.1.10.1	Backplane Connectors X1 and X2	3 - 28
3.1.10.2	Interface for Expanded Memory, Connectors X4 and X8 (CP 581)	3 - 31
3.1.10.3	Interface for Expanded Memory, Connectors X4 and X8 (CP 581/486)	3 - 33
3.1.10.4	Internal, Expanded ISA Bus Connector X10	3 - 35
3.1.11	Memory and Hardware Interrupt Assignments	3 - 37
3.1.11.1	Memory Assignments	3 - 37
3.1.11.2	Hardware Interrupts	3 - 40
3.2	Mass Storage Module	3 - 41
3.2.1	Mechanical Construction	3 - 41
3.2.2	Positions of Floppy Disk Drive and Interfaces on Front Panel	3 - 43
3.2.3	Floppy Disk Drive	3 - 44
3.2.4	Hard Disk Drive	3 - 44
3.2.5	Switch and Jumper Settings	3 - 45
3.2.6	Connection of Devices to Centronics Interface (LPT)	3 - 47
3.2.7	Connection of Devices to the Serial Interface COM 4	3 - 47
3.2.8	External Interface Assignments of Mass Storage Module	3 - 47
3.2.8.1	Parallel Interface (LPT)	3 - 47
3.2.9	Serial Interface COM 4	3 - 49
3.2.10	Internal Interface Assignments	3 - 51
3.2.10.1	Backplane Connectors X1 and X2	3 - 51
3.2.10.2	Internal, Expanded ISA Bus Connector X10	3 - 52
3.3	AT-slot Module	3 - 53
3.3.1	Mechanical Construction of AT-slot Module	3 - 53
3.3.2	Switch and Jumper Settings	3 - 55
3.3.3	External Interface Assignments	3 - 56
3.3.4	Internal Interface Assignments	3 - 59

3.4	Remote Terminal Interface	3 - 61
3.4.1	Power Supply of RTI via Remote Supply from CP 581	3 - 64
3.4.2	Power Supply of RTI by Local, External Supply	3 - 64
3.4.3	Connection of Keyboard to the RTI	3 - 64
3.4.4	Connection of a Mouse to the RTI	3 - 64
3.4.5	Connection of a Light Pen to the RTI (CP 581/486)	3 - 64
3.4.6	Interface and Pin Assignments on the RTI	3 - 65
3.4.7	Connection Cable CP 581 ↔ RTI	3 - 65
3.5	Y Adapter	3 - 69
3.5.1	Assignments of Y Adapter Keyboard/COM 2	3 - 69
3.5.2	Assignments of Y Adapter COM 1/COM 3	3 - 70
3.6	Silicon Disk	3 - 72
3.6.1	Drive Assignments of Silicon Disks	3 - 73
3.6.2	Formatting of Silicon Disks	3 - 74
3.7	SETUP	3 - 77
3.7.1	Starting with Default Device Configuration for the CP 581 Basic Version	3 - 77
3.7.2	Restart of CP 581 with Modified Device Configuration	3 - 77
3.7.3	Restart of CP 581 with Memory Function for the SETUP Setting	3 - 83
3.7.4	BIOS S5 Page	3 - 85
3.7.5	BIOS Options Page (CP 581)	3 - 89
3.7.6	BIOS Options Page (CP 581/486)	3 - 95
3.8	Conversion and Repairs	3 - 99



3.9	Information for Developers of Own System Software	3 - 100
3.9.1	S5 Interface	3 - 100
3.9.2	Interrupt Processing on S5 Interface	3 - 110
3.9.3	Other Status Registers	3 - 114
3.9.4	Peripheral Byte Addressing	3 - 115

3 Reference Section for Hardware

This chapter provides you with detailed information on the hardware design of the CP 581. Each CP 581 component is considered separately. This chapter is divided accordingly.

You can read:

- How the CP 581 components are constructed, and what meaning the switch and jumper settings have,
- Which devices you can connect,
- How the CP 581 interfaces are assigned,
- What the memory and hardware interrupt assignments of the CP 581 are,
- Which interface assignments you require for the development of your own CP 581 system software or your own drivers,
- Information for the developers of own system software.

3.1 Basic Board

3.1.1 Mechanical Construction

The CP 581 basic board (printed-circuit board) is of double Eurocard format and thus suitable for the ES 902 modular packaging system. The front panel width is 1 1/3 standard slots (approx. 20 mm) wide and thus occupies one S5 slot in the main frame of the programmable controller.

The front panel contains the displays and controls as well as the interfaces to the operation and peripheral devices. Fig. 3.1 shows you the design of the CP 581 basic board.

The CP 581 basic board comprises:

- Two 48-pin backplane connectors X1 and X2 according to DIN 41612, series 2, for connecting the CP 581 basic board to the S5 bus (backplane bus) of the programmable controllers (backplane connectors 1 and 2)
- One 26-pin high-density plug for connecting a printer (COM 1) and/or computer coupling (COM 3) using a Y adapter
- One 26-way high-density plug for connecting a keyboard and a mouse (COM 2) using a Y adapter or RTI module
- Three coax midi sockets for connecting the monitor
- One 128-way female connector for connecting the mass storage module (internal ISA bus)
- One 80-way plug connector for connecting an expanded memory with cache
- One 68-way socket for connecting an 80387 SL arithmetic processor
- One RUN/STOP switch for selecting the mode
- RUN/STOP/SD BUSY/FAULT LEDs, RESET key
- One host processor consisting of the chip set 80386 SL and 82360 SL from Intel, with DRAM controller, ISA bus controller and interfaces
- One 4-Mbyte DRAM main memory
- One S5 bus interface (slave)
- VGA graphics with resolution of 1024 x 768 pixels and up to 256 colors (see Chapter 4, Table 4.1)
- One keyboard interface and one keyboard controller
- One 2-Mbyte flash disk, of which 1.3 Mbytes are available to the user, and an interface for a memory card.

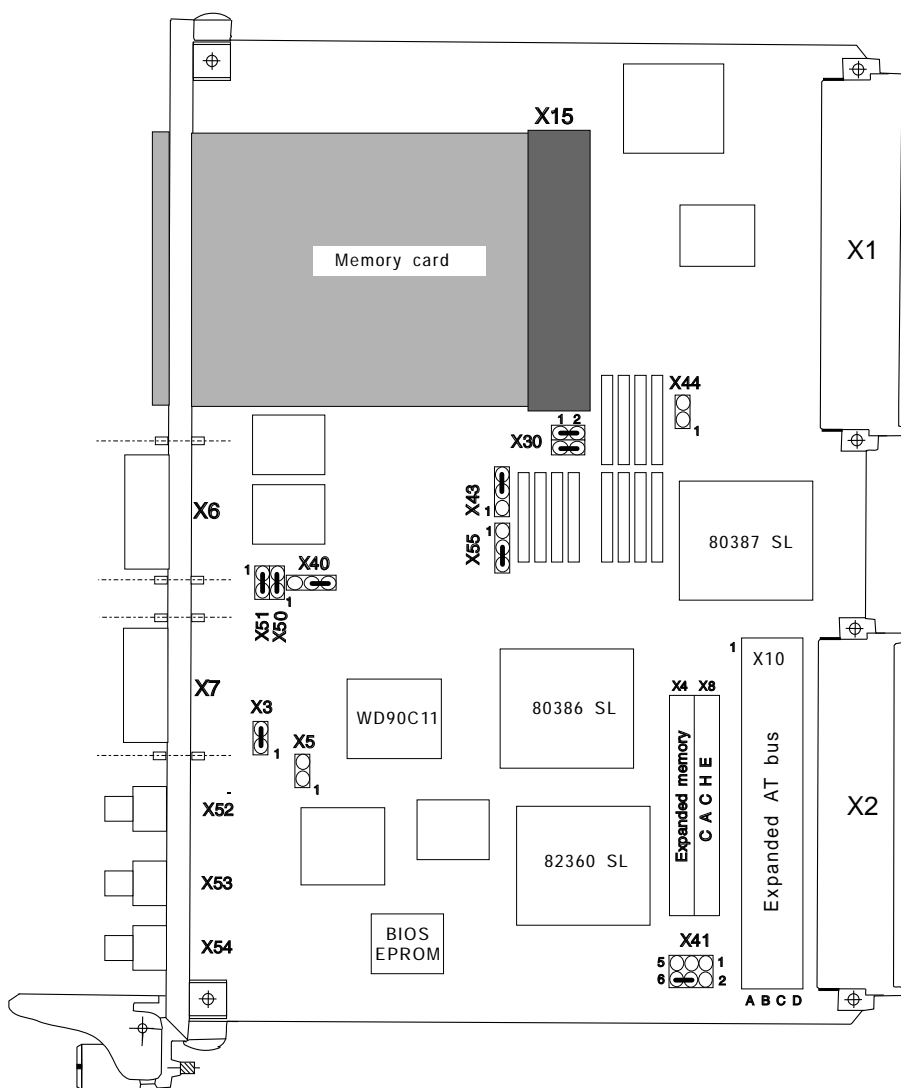

3

Fig. 3.1 Design of CP 581 basic board

The CP 581/486 basic board comprises:

- Two 48-pin backplane connectors X1 and X2 according to DIN 41612, series 2, for connecting the CP 581/486 basic board to the S5 bus (backplane bus) of the programmable controllers (backplane connectors 1 and 2)
- One 26-pin high-density plug for connecting a printer (COM 1) and/or computer coupling (COM 3) using a Y adapter
- One 26-way high-density plug for connecting a keyboard and a mouse or a light pen (COM 2) using a Y adapter or RTI module
- Three coax midi sockets for connecting the monitor
- One 128-way female connector for connecting the mass storage module (internal ISA bus)
- One 80-way plug connector for connecting an expanded memory
- One RUN/STOP switch for selecting the mode
- RUN/STOP/SD BUSY/FAULT LEDs, RESET key
- One host processor consisting of the chip set 80486 SL and 82360 SL from Intel, with DRAM controller, ISA bus controller and interfaces
- One 4-Mbyte DRAM main memory
- One S5 bus interface (slave)
- VGA graphics resolution (see Chapter 4, Table 4.2)
- One keyboard interface and one keyboard controller
- One 2-Mbyte flash disk, of which 1.3 Mbytes are available to the user, and an interface for a memory card.

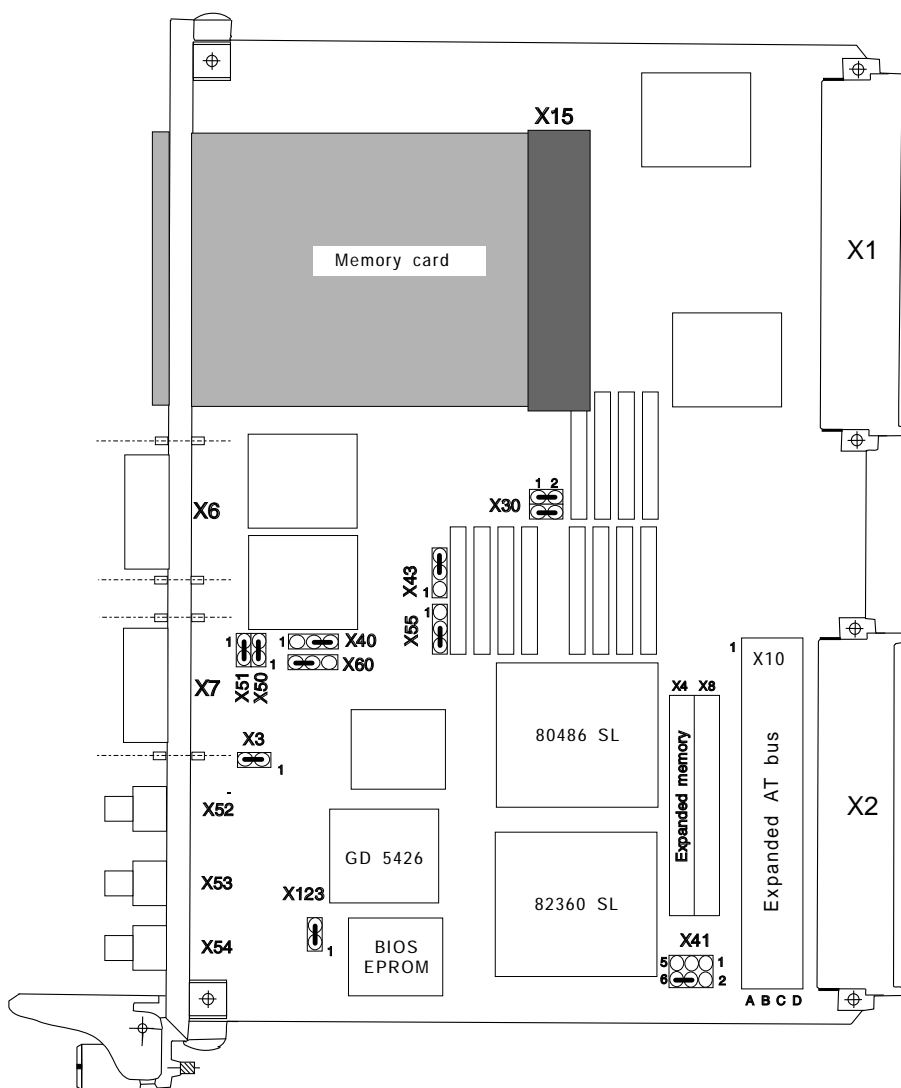

Fig. 3.2 Design of CP 581/486 basic board

3.1.2 Controls and Displays

Fig. 3.3 shows you the positions of the controls and displays on the front panel of the basic board.

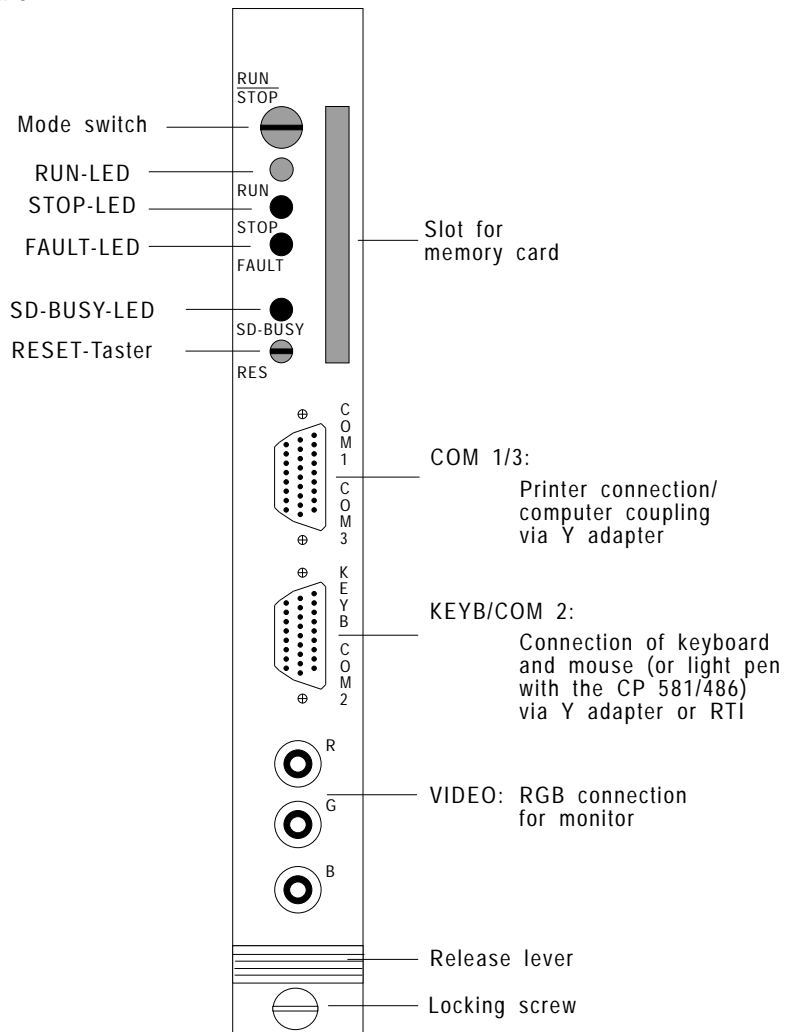

Fig. 3.3 Positions of controls, displays and interfaces on the basic board

Controls:**- Switch - RUN/STOP -**

Switching from RUN to STOP:

Bus communication at the S5 interface is disabled.

A RESET-ALL is triggered at the CP 581 end and completely resets the CPDHB driver. (This corresponds to triggering of a RESET-ALL by the corresponding DHB at the CPU end).

Switching from STOP to RUN:

Data transfer at the S5 interface is enabled again.

- Key - RESET -

Pressing this key completely resets the board.

Communication is then **aborted in an undefined manner!**
The error condition code "Interface not ready" is passed on to the S5 CPU.

3**Displays:**

The displays are divided into:

- Operation displays
- Fault displays
- Access displays for the drives.

Operation and fault displays:

- Green LED - RUN -

Signals the status "S5 interface in operation"; the LED can only light up if the mode switch is set to RUN and if at least one CPU is synchronized.

- **Red LED** - **STOP** -
 Continuous light signals the status "S5 interface not in operation" if the mode switch is set to STOP.
 Flashing signals the status "Mode switch at RUN", but no CPU synchronized.
- **Green LED** - **SD BUSY** -
 Lights up during access operations to the onboard silicon disk and the memory card.
- **Red LED** - **FAULT** -
 This LED is deleted by the BIOS during the CP restart if the CP hardware is ready.

The following table shows you the meaning of the displays:

Table 3.1 Operation and fault displays on the LEDs

FAULT LED *	RUN LED	STOP LED	Meaning
0	0	0	CPDHB driver is not yet loaded on the CP 581.
0	0	1 (continuous)	RUN/STOP switch in STOP position.
0	0	Flashing	RUN/STOP switch in RUN position. CP 581 is not synchronized with any CPU.
0	1	0	RUN/STOP switch in RUN position. At least one CPU is synchronized.
1	0	1	BIOS error stop (fault in running-up of CP 581)
0	Flashing 3 times/sec	0	CPLINK active without connection
0	Flashing once/sec	0	CPLINK active with connection

* The FAULT LED goes off during the restart.
 If this LED does not go off, please contact your Siemens representative.

3.1.3 Switch and Jumper Settings

The coding switches and plug-in jumpers present on the basic board have been factory-set. You need not check or reset them provided you wish to use the CP 581 components in their default configuration.

The following sections provide you with further information on the coding switches and plug-in jumpers.

Figs. 3.1 and 3.2 show the positions of the switches and jumpers.

Jumpers present on CP 581 and on CP 581/486:

- **Plug-in jumper X3**

PINx - PINy	Effect
1 – 2	PG 750 keyboard (default setting)
No jumper	Standard keyboard

3

- **Plug-in jumper X41 for CP 581**

PINx - PINy	Effect
1 – 3	COM 3 interrupt on IRQ 5
3 – 5	COM 3 interrupt on IRQ 10
2 – 4	COM 3 interrupt on IRQ 4
4 – 6	COM 3 interrupt on IRQ 11 (default setting)
No jumper	COM 3 interrupt not connected

- **Plug-in jumper X41** for CP 581/486

The jumper X41 has the following assignments on the CP 581/486, in contrast to the CP 581:

PINx - PINy	Effect
1 – 2	COM 3 interrupt on IRQ 5
3 – 5	COM 3 interrupt on IRQ 10
2 – 4	COM 3 interrupt on IRQ 4
5 – 6	COM 3 interrupt on IRQ 11 (default setting)
No jumper	COM 3 interrupt not connected

- **Plug-in jumper X50**

PINx - PINy	Effect
1 – 2	COM 1: "TTY receive" active (default setting)
No jumper	COM 1: "TTY receive" passive

- **Plug-in jumper X51**

PINx - PINy	Effect
1 – 2	COM 1: "TTY transmit" active (default setting)
No jumper	COM 1: "TTY transmit" passive

- **Plug-in jumper X40**

PINx - PINy	Effect
1 – 2	COM 2 RS 485
2 - 3	COM 2 RS 422 (default setting) ¹⁾
No jumper	Illegal

1) Jumper must be inserted for use with a mouse via RTI.

- **Plug-in jumper X55**

PINx - PINy	Effect
1 – 2	Illegal
2 - 3	Watchdog triggers reset (default setting)
No jumper	Watchdog has no effect

3

- **Plug-in jumper X43**

PINx - PINy	Effect
1 – 2	COM 3 RS 485
2 - 3	COM 3 RS 422 (default setting)
No jumper	Illegal

- **Plug-in jumper X30**

PINx - PINy	Effect
1 – 2	No effect
3 - 4 inserted	Onboard VGA activated (default setting)
3 - 4 open	Onboard VGA deactivated

Additional jumpers on CP 581/486:

- **Plug-in jumper X60**

PINx - PINy	Effect
1 – 2	RI (signal "Ring Indicator") on COM2 (e.g. for use of a modem, default setting)
2 - 3	Light pen operation via COM2

- **Plug-in jumper X123**

PINx - PINy	Effect
1 – 2	Sync green (default setting) (VGA)
open	No Sync green

3.1.4 Connection of Printers

We recommend the following Siemens printers if you wish to connect a printer to COM 1 of the Y adapter COM1/COM 3:

Table 3.2 Recommended printers

Printer	Printing principle	Paper	Order No.
DR 210-N	9-needle printer	A4, 8 1/4" x 11 3/4"	6AP1800-0AA00
DR 211-N	9-needle printer	A3, 16 1/2" x 11 3/4"	6AP1800-0BA00
DR 230-N	24-needle printer	A4 8 1/4" x 11 3/4"	6AP1800-0CA00
DR 231-N	24-needle printer	A3 16 1/2" x 11 3/4"	6AP1800-0DA00

3

All printers listed here have the following common technical data:

- 250 characters/second with 10 characters/inch
- Centronics, V.24 and TTY interfaces
- ANSI, EPSON and IBM-compatible (DR 210-N and DR 211-N)
- ANSI, EPSON, IBM, NEC and ECMA-compatible (DR 230-N and DR 231-N)
- Low noise level.

Refer to Chapter 6, Ordering Information, for the order nos. of suitable interfaces and cable connectors.

Please note that you must order the interfaces and cable connectors separately.

You can obtain further information from Catalogs ST 52.1 and IPC 13 as well as the corresponding printer descriptions.

3.1.5 Connection of Keyboard

We recommend the connection of a PG 750 keyboard.

- **Connection via the Y adapter Keyboard/COM 2**

Connect the keyboard to the 7-way round socket of the Y adapter.

- **Connection via the remote terminal interface**

Connect the keyboard to the 7-way round socket X2 of the RTI module.

3.1.6 Connection of a Mouse

The CP 581 software supplied does not use a mouse.

You can nevertheless use a mouse if this is supported by the MS-DOS programs which you use on the CP 581.

We recommend the connection of a PG 750 mouse.

- **Connection via the Y adapter Keyboard/COM 2**

Connect the mouse to the 9-pin D-subminiature plug of the Y adapter.

- **Connection via the remote terminal interface**

Connect the mouse to the 9-pin D-subminiature plug X3 of the RTI module.

The mouse must not be connected to the PG 750 keyboard!

3.1.7 Connection of a Light Pen

The light pen can be connected to the CP 581/486 as described below:

- **Connection via the Y adapter Keyboard/COM 2**

Connect the light pen to the 9-pin D-subminiature plug of the Y adapter. Note that the jumper X60 on the basic board of the CP 581/486 must be plugged on 2-3 for the light pen.

- **Connection via the remote terminal interface**

Connect the light pen to the 9-pin D-subminiature plug X3 of the RTI module.

Note



If you want to write your own software for the connection of a light pen, you will require additional information for its programming interface.

3

3.1.8 Connection of a Monitor

We recommend a monitor where the video ground can be separated from the protective ground.

It is essential that you observe the design and connection guidelines for monitors in Section 2.8.2!

3.1.9 External Interface Assignments

When connecting the operation devices and the peripheral devices, please note that you require the Y adapter listed in Chapter 6, Ordering Information, when using standard cables.

3.1.9.1 Combined Plug X6 for the Serial Interfaces COM 1 and COM 3

The combined plug for the serial interfaces COM 1 and COM 3 is designed as a 26-pin high-density plug.

The serial interface COM 1 has V.24 transmission signals plus the signals for active TTY mode (20 mA).

It is compatible with the industrial standard and can be used to connect printers with serial interfaces.

The serial interface COM 3 has V.24 and X27 transmission signals and can be used for computer coupling.

The signals from COM 1 and COM 3 are converted to the 25-pin D-subminiature plug via the Y adapter COM 1/COM 3.

Table 3.3 Pin assignments of plug X6

Pin	Signal	Signal class
1	RI	COM 1 V.24
2	DCD	COM 1 V.24
3	RTS	COM 1 V.24
4	RxD+	COM 3 X27
5	RxD-	COM 3 X27
6	TxD+	COM 3 X27
7	TxD-	COM 3 X27
8	RTS	COM 3 V.24
9	CTS	COM 3 V.24
10	DSR	COM 1 V.24
11	RxD	COM 1 V.24
12	GND	COM 1 V.24
13	P24V	COM 1 TTY
14	RxD+	COM 1 TTY

Pin	Signal	Signal class
Table 3.3 continued:		
15	TxD+	COM 1 TTY
16	DCD	COM 3 V.24
17	DSR	COM 3 V.24
18	GND	COM 3 V.24
19	TxD	COM 1 V.24
20	DTR	COM 1 V.24
21	CTS	COM 1 V.24
22	RxD-	COM 1 TTY
23	TxD-	COM 1 TTY
24	TxD	COM 3 V.24
25	RxD	COM 3 V.24
26	DTR	COM 3 V.24

3

Note: The COM 3 interface does not have an RI signal.

3.1.9.2 Combined Plug X7 for the Keyboard and Serial Interface COM 2 (Mouse)

The combined plug for the keyboard and the serial interface COM 2 is designed as a 26-pin high-density plug.

It has TTL signals for the keyboard interface, V.24 signals for the mouse connection (or the light pen connection), RS 485 signals for the RTI interface and a 24-V power supply.

The signals are converted to the round keyboard socket (KBD connection) and a 9-pin D-subminiature plug via the Y adapter Keyboard/COM 2 (max. 1.5 m).

You can cover larger distances (max. 250 m) between the CP 581 and the keyboard/mouse using the remote terminal interface.

Table 3.4 Pin assignments of plug X7 for keyboard and COM 2

Pin	Signal	Signal class
1	K_DATA	Keyboard direct
2	K_CLK	Keyboard direct
3	P5V	Keyboard direct
4	TxD	COM 2 V.24
5	RTS	COM 2 V.24
6	DTR	COM 2 V.24
7	Not used	
8	RTS-	COM 2 remote ¹⁾
9	RTS+	COM 2 remote ¹⁾
10	K_DATA+	Keyboard remote
11	K_CLK+	Keyboard remote
12	GND	
13	RxD	COM 2 V.24

Pin	Signal	Signal class
Table 3.4 continued:		
14	CTS	COM 2 V.24
15	DSR	COM 2 V.24
16	RI	COM 2 V.24
17	DCD	COM 2 V.24
18	M24V	Remote supply
19	K_DATA-	Keyboard remote
20	K-CLK-	Keyboard remote
21	GND	
22	RxD+	COM 2 remote
23	RxD-	COM 2 remote
24	TxD+	COM 2 remote
25	TxD-	COM 2 remote
26	P24V	Remote supply

¹⁾ only with CP 581/486

3.1.9.3 Plug X15 for a Memory Card

68-pin connector for a memory card

Table 3.5 Pin assignments of plug X15 for a memory card

Pin	Signal	Function	I/O
1	GND	Ground	
2	D3	Data bit 3	I/O
3	D4	Data bit 4	I/O
4	D5	Data bit 5	I/O
5	D6	Data bit 6	I/O

Pin	Signal	Function	I/O
Table 3.5 cont. (2/4)			
6	D7	Data bit 7	I/O
7	CE1_N	Enable Low byte	I
8	A10	Address bit 10	I
9	RD_N	Read	I
10	A11	Address bit 11	I
11	A9	Address bit 9	I
12	A8	Address bit 8	I
13	A13	Address bit 13	I
14	A14	Address bit 14	I
15	WR_N	Write	I
16	DERR_N	Data error	O
17	VCC	Power supply	
18	VPP1	Programmable voltage low byte	
19	A16	Address bit 16	I
20	A15	Address bit 15	I
21	A12	Address bit 12	I
22	A7	Address bit 7	I
23	A6	Address bit 6	I
24	A5	Address bit 5	I
25	A4	Address bit 4	I
26	A3	Address bit 3	I
27	A2	Address bit 2	I
28	A1	Address bit 1	I
29	A0	Address bit 0	I
30	D0	Data bit 0	I/O

Pin	Signal	Function	I/O
Table 3.5 cont. (3/4)			
31	D1	Data bit 1	I/O
32	D2	Data bit 2	I/O
33	WP	Write protect	O
34	GND	Ground	
35	GND	Ground	
36	CD1/DS_N	Cdetect 1/data save	I/O
37	D11	Data bit 11	I/O
38	D12	Data bit 12	I/O
39	D13	Data bit 13	I/O
40	D14	Data bit 14	I/O
41	D15	Data bit 15	I/O
42	CE2_N	Enable High bit	I
43	RFSH	Refresh	I
44	Ubatt	Ubatt external	
45			
46	A17	Address bit 17	I
47	A18	Address bit 18	I
48	A19	Address bit 19	I
49	A20	Address bit 20	I
50	A21	Address bit 21	I
51	VCC	Power supply	
52	VPP2	Programmable voltage high byte	
53	A22	Address bit 22	I
54	A23	Address bit 23	I
55	A24/SEL1	Address bit 24 *	I

Pin	Signal	Function	I/O
Table 3.5 cont. (4/4)			
56	A25/SEL0	Address bit 25 *	I
57			
58			
59			
60			
61	EKS_N	Enable identifier bit voltage	I
62	BVD2	Battery detect 2	O
63	BVD1	Battery detect 1	O
64	D8	Data bit 8	I/O
65	D9	Data bit 9	I/O
66	D10	Data bit 10	I/O
67	CD2_N	Cdetect	O
68	GND	Ground	

* SEL0 and SEL1 are selection signals for hybrid modules

Leading signal connections:

17, 51 (V_{CC})

1, 34, 35, 68 (ground)

Lagging signal connections:

36 (CD1/DS_N)

67 (CD2)

3.1.9.4 Video Outputs

You can connect a VGA monitor to the three coax midi sockets on the front panel of the CP 581 basic board via a double-screened coaxial cable (triax cable) up to a distance of 250 m.

The sockets are used for the following signals:

- Red (R)
- Green/sync signal (G/S) and
- Blue (B).

	Caution
	The sockets are not floating.

3

Conversion of RGB signals to VGA multisync

Using the RGB/VGA adapter listed in Chapter 6 (Ordering Information), you can convert the RGB signal onto a 15-pin standard VGA plug for laboratory or test purposes.

	Note
	Note when using this adapter circuit that: <ul style="list-style-type: none">- The noise immunity is reduced- The monitor can only be installed up to a max. distance of 1.5 m- It is not sufficient if the monitor is a multisync or multifrequency monitor - it must additionally be able to derive the sync signals from the green signal.

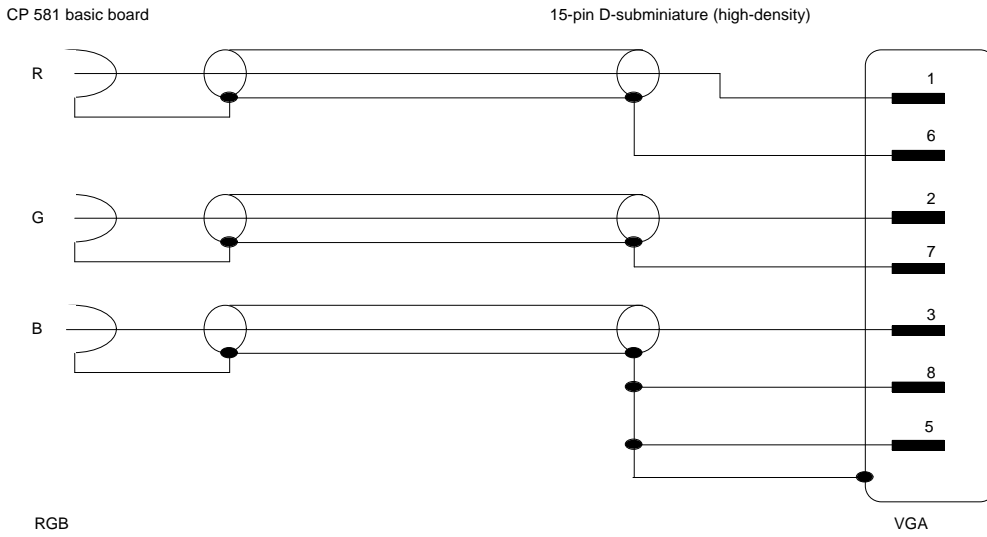

Fig. 3.4 Wiring diagram of RGB/VGA adapter

3.1.10 Internal Interface Assignments

3.1.10.1 Backplane Connectors X1 and X2

The CP 581 basic board is connected to the bus board of the programmable controller via two 48-pin backplane connectors of series 2. The pin assignments of these two backplane connectors are shown in the following tables.

Table 3.6 Pin assignments of backplane connector X1 (top of basic board)

	d	b	z
2	-	Ground	+5 V
4	UBATT	-	-
6	ADB 12	ADB 0	-
8	ADB 13	ADB 1	/MEMR

	d	b	z
Table 3.6 continued:			
10	ADB 14	ADB 2	/MEMW
12	ADB 15	ADB 3	/RDY
14	IRA_N	ADB 4	DB 0
16	IRB_N	ADB 5	DB 1
18	IRC_N	ADB 6	DB 2
20	IRD_N	ADB 7	DB 3
22	-	ADB 8	DB 4
24	-	ADB 9	DB 5
26	-	ADB 10	DB 6
28	/DSI	ADB 11	DB 7
30	-	-	-
32	-	Ground	-

3

The bus signals are mainly connected to backplane connector X1, the module power supply is additionally connected via backplane connector X2.

Table 3.7 Pin assignments of backplane connector X2 (bottom of basic board)

	d	b	z
2	-	Ground	+5 V
4	-	-	-
6	-	-	-
8	-	-	-
10	-	-	-

	d	b	z
Table 3.7 continued:			
12	-	-	-
14	-	-	/NAU
16	-	-	-
18	-	-	-
20	-	-	-
22	-	-	-
24	-	-	-
26	-	-	-
28	-	-	-
30	-	M2	M2
32	-	Ground	+24 V

3.1.10.2 Interface for Expanded Memory, Connectors X4 and X8 (CP 581)

Table 3.8 Pin assignments of connectors X4 and X8 for expanded memory (CP 581)

Connector X4		Connector X8	
Pin	Signal name	Pin	Signal name
1	MD0	1	RA2
2	MD8	2	MA0
3	MD1	3	CAL2
4	MD9	4	MA1
5	MD2	5	CAH2
6	MD10	6	MA2
7	MD3	7	RA3
8	MD11	8	MA3
9	GND	9	CAL3
10	MD12	10	P5V
11	MD4	11	CAH3
12	MD13	12	MA4
13	MD5	13	WL_N
14	MD14	14	MA5
15	MD6	15	WH_N
16	MD15	16	MA6
17	MD7	17	GND
18	PARH	18	MA7
19	PARL	19	ID1

3

Connector X4		Connector X8	
Pin	Signal name	Pin	Signal name
Table 3.8 continued:			
20	ID0	20	MA8
21	CCSL	21	CWE_N
22	CCSH	22	MA9
23	CDB0	23	COE_N
24	GND	24	MA10
25	CDB1	25	CAB1
26	CDB8	26	CAB9
27	CDB2	27	CAB2
28	CDB9	28	CAB10
29	CDB3	29	CAB3
30	CDB10	30	CAB11
31	P5V	31	CAB4
32	CDB11	32	GND
33	CDB4	33	CAB5
34	CDB12	34	CAB12
35	CDB5	35	CAB6
36	CDB13	36	CAB13
37	CDB6	37	CAB7
38	CDB14	38	CAB14
39	CDB7	39	CAB8
40	CDB15	40	CAB15

3.1.10.3 Interface for Expanded Memory, Connectors X4 and X8 (CP 581/486)

Table 3.9 Pin assignments of connectors X4 and X8 for expanded memory (CP 581/486)

Connector X4		Connector X8	
Pin	Signal name	Pin	Signal name
1	MD0	1	PD3
2	MD8	2	MA0
3	MD1	3	CA10
4	MD9	4	MA1
5	MD2	5	CA11
6	MD10	6	MA2
7	MD3	7	CA12
8	MD11	8	MA3
9	M	9	nc
10	MD12	10	P5V
11	MD4	11	CA20
12	MD13	12	MA4
13	MD5	13	WE_N0
14	MD14	14	MA5
15	MD6	15	WE_N1
16	MD15	16	MA6
17	MD7	17	M
18	PD1	18	MA7

3

Connector X4		Connector X8	
Pin	Signal name	Pin	Signal name
Table 3.9 continued:			
19	PD0	19	ID1
20	ID0	20	MA8
21	RAS1	21	WE_N2
22	RAS2	22	MA9
23	MD16	23	WE_N3
24	M	24	MA10
25	MD17	25	CA21
26	MD25	26	MA11
27	MD18	27	CA22
28	MD25	28	MA12
29	MD19	29	CA23
30	MD26	30	RAS3
31	P5V	31	CA30
32	MD27	32	M
33	MD20	33	CA31
34	MD28	34	CA40
35	MD21	35	CA32
36	MD29	36	CA41
37	MD22	37	CA33
38	MD30	38	CA42
39	MD23	39	PD2
40	MD31	40	CA43

3.1.10.4 Internal, Expanded ISA Bus Connector X10

Table 3.10 Pin assignments of ISA bus connector X10

Row	A	B	C	D
Pin	Signal			
1	P12V	P5V	NC	P5V
2	P12V	SD15	SD14	GND
3	SD7	SD6	SD13	P5V
4	SD4	SD5	SD12	IDEN_N
5	SD3	SD10	SD11	GND
6	SD2	SD0	SD9	SYSCLK2
7	SD1	GND	SD8	GND
8	IOCHK_N	GND	IOCHRDY	CLISA14M
9	SA0	SA1	AEN	GND
10	SA2	SA3	SA13	P5V
11	SA4	SA5	SA14	CSFLASH
12	SA6	SA7	SA15	PW/R
13	SA8	SA9	SA16	GND
14	SA10	SA11	SA17	PSTART
15	SA12	SBHE_N	SA18	PMIO
16	LA17	LA18	SA19	PRDY
17	LA20	LA21	LA19	PCMD
18	LA23	RESDRV	LA22	GND
19	IOW_N	BALE	OWS_N	DRQ3

3

Row	A	B	C	D
Pin	Signal			
Table 3.10 continued:				
20	IOR_N	GND	SMEMW_N	DACK3_N
21	NC	IRQ6	SMEMR_N	GND
22	DRQ0	IRQ12	DACK0_N	IRQ3
23	IRQ5	GND	IRQ9	IRQ7
24	IRQ11	SYSCLK	IRQ10	IRQ4
25	IRQ15	GND	IRQ14	GND
26	TC	DACK1_N	REFRSH_N	1_8432MHz
27	DRQ1	P5V	IOCS16_N	GND
28	DRQ2	DACK2_N	MCS16_N	NAU
29	DRQ5	GND	MASTER_N	P5V
30	DACK5_N	DRQ7	MEMR_N	GND
31	DRQ6	DACK7_N	MEMW_N	1M
32	DACK6_N	P5V	GND	P24V

3.1.11 Memory and Hardware Interrupt Assignments

3.1.11.1 Memory Assignments

In the assignment of the address areas, a differentiation is made between
- the memory address area and
- the I/O address area.

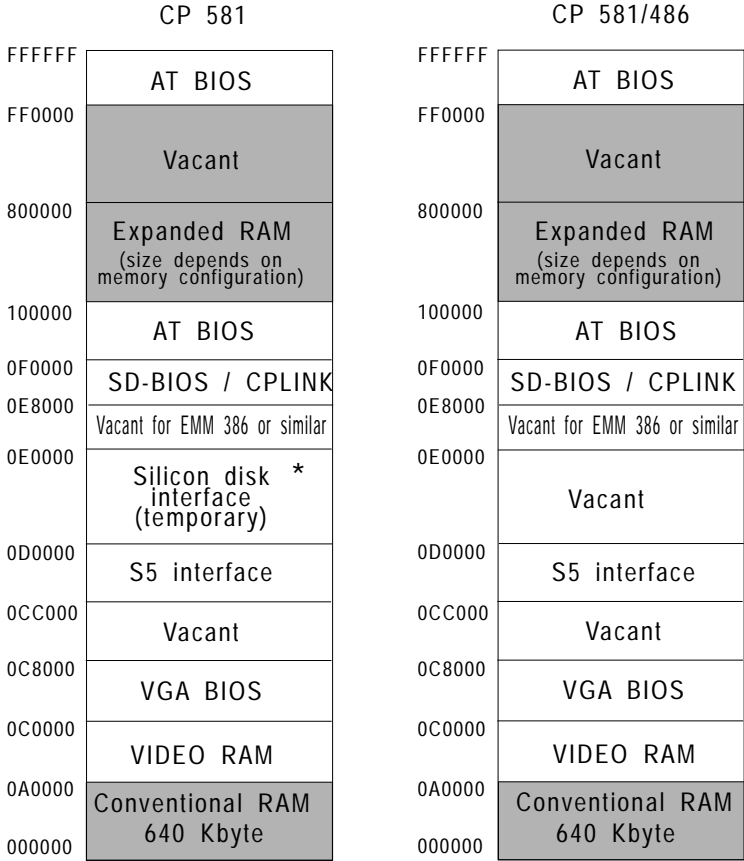

* This address area can also be used by AT modules if it is ensured that no access operations to the AT module take place during access operations to the silicon disk.

Fig. 3.5 Assignment of memory address area

Table 3.11 Assignment of I/O address area

Address area	Component/module
0000H-001FH	DMA controller 1 (8237A-5 included in 82360SL)
0020H-0021H	Interrupt controller 1 (master 8259A included in 82360SL)
0022H-0003H	Reserved
0040H-005FH	Timer (8254.2 included in 82360SL)
0060H-0064H	Keyboard controller (8742), port B, port C, port D
0070FH-007FH	Real-time clock, NMI enable
0080FH-009FH	DMA page register (74LS612 included in 82360SL)
00A0H-00A1H	Interrupt controller 2 (slave 8259A included in 82360SL)
00A2H-00BFH	Reserved
00C0H-00DFH	Interrupt controller 2 (8237A-5 included in 82360SL)
00E0H-00EFH	Reserved
00F0H-00FFH	Numeric processor (80387SL only with CP 581)
0100H-010FH	Reserved for SINEC H1
0110H-014FH	Reserved for CP-58x internal
0150H-016FH	Not used
0170H-0177H	Reserved for hard disk controller 2
0178H-01EFH	Not used
01F0H-01FFH	Hard disk controller 1
0200H-0207H	Reserved (game I/O)
0208H-0277H	Reserved
0278H-027FH	Reserved (parallel interface 2)
0280H-02E7H	Reserved

Address area	Component/module
Table 3.11 continued:	
02E8H-02EFH	Serial interface COM 4, mass storage
02F0-02F7H	Reserved
02F8H-02FFH	Serial interface COM 2, basic board
0300H-031FH	Reserved (prototype card)
0320H-033FH	Not used
0340H-035FH	Reserved
0360H-036FH	Reserved (IBM PC NET)
0370H-0377H	Reserved (floppy controller 2)
0378H-037FH	LPT 1, mass storage
0380H-03AFH	Reserved
03B0H-03BFH	B/W monitor interface or EGA/VGA
03C0H-03CFH	Color graphics interface EGA/VGA
03D0H-03DFH	Color graphics interface CGA/EGA/VGA
03E0H-03E7H	Not used
03E8H-03EFH	Serial interface COM 3, basic board
03F0H-03F7H	Floppy controller
03F8H-03FFH	Serial interface COM 2, basic board
0400H-4FFFH	Reserved
5000H-55FFH	S5 interface and silicon disk interface (CP 581/486)
5600H-FFFFH	Reserved

3.1.11.2 Hardware Interrupts

Table 3.12 Summary of hardware interrupts

Interrupt number	Meaning
NMI	RAM parity, AT bus error (IOCHCHK), RESET key, power failure
IRQ 0	System timer
IRQ 1	Keyboard
IRQ 2	Interrupt controller 2
IRQ 3	COM 2
IRQ 4	COM 1 (COM 3)
IRQ 5	Not used (COM 3, COM 4)
IRQ 6	Floppy disk drive
IRQ 7	LPT
IRQ 8	Real-time clock
IRQ 9	Software interrupt derived from 0AH (IRQ 2)
IRQ 10	Not used (COM 3, COM 4)
IRQ 11	COM 3 (COM 4)
IRQ 12	COM 4
IRQ 13	Numeric processor
IRQ 14	Hard disk
IRQ 15	S5 interface

The interrupts "COM 3", "COM 4" and "Watchdog" can be reconfigured using plug-in jumpers.

3.2 Mass Storage Module

3.2.1 Mechanical Construction

The CP 581 mass storage module (printed-circuit board) is of double Eurocard format and thus suitable for the ES 902 modular packaging system. The front panel width, including the integrated floppy disk and hard disk drives, is $1 \frac{1}{3}$ standard slots (approx. 20 mm) wide and thus occupies one S5 slot in the main frame of the programmable controller.

The front panel contains the BUSY LEDs for the hard disk and floppy disk drives, the reject key of the 3.5-inch floppy disk drive and interfaces to the peripheral devices. Fig. 3.6 shows you the design of the CP 581 mass storage module.

The mass storage module comprises:

- Two 48-pin backplane connectors according to DIN 41 612, series 2, for connecting the CP 581 mass storage module to the S5 bus (backplane bus) of the programmable controllers (backplane connectors 1 and 2)
- One 25-pin D-subminiature plug (LPT) for connecting a dongle or a printer with parallel interface
- One 26-pin high-density plug for the parameterizable serial interface COM 4
- One 128-way plug connector for connecting the basic board (internal ISA bus)
- One LED "HD"
- One hard disk (2.5-inch) with IDE interface
- One 3.5-inch slimline floppy disk drive.

3

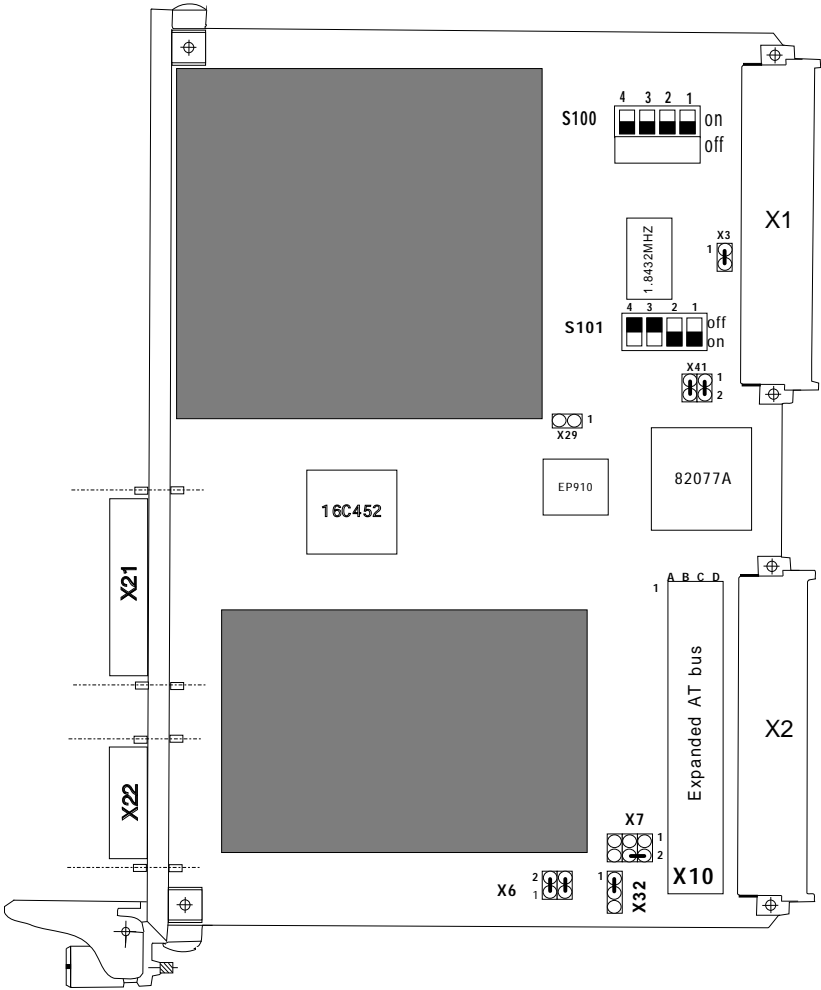
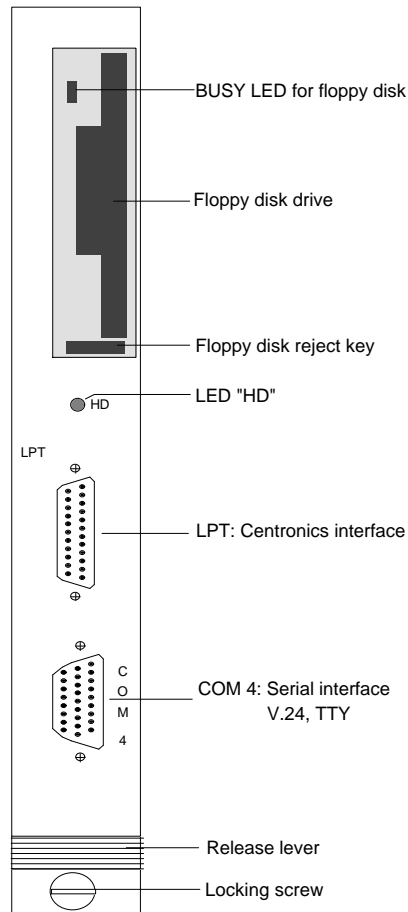

Fig. 3.6 Design of CP 581 mass storage module

3.2.2 Positions of Floppy Disk Drive and Interfaces on Front Panel

Fig. 3.7 shows you the positions of the floppy disk drive and the interfaces on the front panel of the mass storage module.



3

Fig. 3.7 Front panel of mass storage module

3.2.3 Floppy Disk Drive

The floppy disk must not be used when the BUSY LED on the drive is lit.

The 3.5-inch floppy disk drive of the CP 581 mass storage module is connected to the disk interface of the 37C65 floppy controller via a 26-pin connector. Double-sided 3.5-inch floppy disks can be used (80 tracks per side), either high density with 1.44 Mbytes or double density with 720 Kbytes. The drive is automatically adapted to the type of disk by scanning the HD opening in the disk.

3.2.4 Hard Disk Drive

The hard disk drive automatically moves to the transport position when switched off.

The 2.5-inch hard disk drive of the CP 581 mass storage module is connected to the AT bus via a 50-pin plug connector. The hard disk is equipped with a PC/AT interface.

The total capacity of the hard disk of version -0LA11 is 60 Mbytes.
The total capacity of the hard disk of version -1LA11 is 120 Mbytes.

Logical drives can be produced depending on the operating system. Please refer to the description of the operating system for more information.

The LED "HD" lights up on the front panel of the CP 581 mass storage module when the hard disk is being accessed.

3.2.5 Switch and Jumper Settings

The coding switches and plug-in jumpers present on the mass storage module have been factory-set. You need not check or reset them provided you wish to use the CP 581 components in their default configuration.

The following sections provide you with further information on the coding switches and plug-in jumpers. Fig. 3.6 shows the positions of the switches and jumpers.

- **Switch S101**

Table 3.13 Default setting of switch S101

Switch	Default		ON	OFF
	ON	OFF		
1	X		Spare	
2	X		COM 4 switched on	COM 4 switched off
3		X	Spare	
4		X	Spare	

3

- **Plug-in jumper X6**

Table 3.14 Default setting of plug-in jumper X6

PINx - PINy	Effect
1 - 2	"TTY transmit" active (jumper inserted on delivery)
3 - 4	"TTY receive" active (jumper inserted on delivery)
No jumper	TTY passive

- **Plug-in jumper X7**

Table 3.15 Default setting of plug-in jumper X7

PINx - PINy	Effect
1 - 2	COM 4 interrupt at IRQ 5
5 - 3	COM 4 interrupt at IRQ 11
2 - 4	COM 4 interrupt at IRQ 12 (default setting)
5 - 6	COM 4 interrupt at IRQ 10
No jumper	COM 4 occupies no interrupt

- **Plug-in jumper X32**

Table 3.16 Default setting of plug-in jumper X32

PINx - PINy	Effect
1 - 2	LPT interrupt at IRQ 7 (default setting)
2 - 3	LPT interrupt at IRQ 5
No jumper	LPT occupies no interrupt

3.2.6 Connection of Devices to Centronics Interface (LPT)

The printers recommended in Section 3.1.4 can be connected to the Centronics interface.

Please refer to Chapter 6, Ordering Information, for the order nos. of devices for connection to the Centronics interface and of suitable cable connectors.

Please note that you must order the cable connectors separately.

3.2.7 Connection of Devices to the Serial Interface COM 4

You can connect external devices with a serial interface to COM 4. Proceed as described in Section 3.1.4.

The Y adapter for COM 1/COM 3 can also be used for COM 4. In this case the "COM 1 side" of the Y adapter is a standard COM 4 interface.

3

3.2.8 External Interface Assignments of Mass Storage Module

3.2.8.1 Parallel Interface (LPT)

The parallel interface LPT (Centronics) has a 25-pin D-subminiature plug. It is used to connect a printer up to 3 m away or for connecting a dongle for protected programs.

Table 3.17 Signal assignments of the parallel interface LPT (Centronics)

Pin	Signal	Signal class I/O
1	STB_N	O
2	PDB0	O (data)
3	PDB1	O (data)
4	PDB2	O (data)

Pin	Signal	Signal class I/O
Table 3.17 continued:		
5	PDB3	O (data)
6	PDB4	O (data)
7	PDB5	O (data)
8	PDB6	O (data)
9	PDB7	O (data)
10	ACK_N	I
11	BUSY	I
12	PE	I
13	SLC_IN	I
14	AFD_N	O
15	ERR_N	I
16	INIT_N	O
17	SLIN	O
18-25	GND	Ground

3.2.9 Serial Interface COM 4

The plug of interface COM 4 is designed as a 26-pin high-density plug. The serial interface COM 4 has the standard assignments of the V.24 transmission signals plus the signals for active TTY operation (20 mA).

Table 3.18 Signal assignments of the serial interface COM 4

Pin	Signal	Signal class
1	RI	COM 4 V.24
2	DCD	COM 4 V.24
3	RTS	COM 4 V.24
4	Not used	
5	Not used	
6	Not used	
7	Not used	
8	Not used	
9	Not used	
10	DSR	COM 4 V.24
11	RxD	COM 4 V.24
12	GND	COM 4 V.24
13	P24V	COM 4 TTY
14	RxD+	COM 4 TTY
15	TxD+	COM 4 TTY
16	Not used	
17	Not used	

3

Pin	Signal	Signal class
Table 3.18 continued:		
18	Not used	
19	TxD	COM 4 V.24
20	DTR	COM 4 V.24
21	CTS	COM 4 V.24
22	RxD-	COM 4 TTY
23	TxD-	COM 4 TTY
24	Not used	
25	Not used	
26	Not used	

3.2.10 Internal Interface Assignments

3.2.10.1 Backplane Connectors X1 and X2

The CP 581 mass storage module is connected to the bus board of the programmable controller via two 48-pin backplane connectors of series 2. The pin assignments of these two backplane connectors are shown in the following tables.

Table 3.19 Pin assignments of backplane connector X1 (top of mass storage module)

	d	b	z
2	-	Ground	+5 V
4	-	-	-
6	-	-	-
8	-	-	-
10	-	-	-
12	-	-	-
14	-	-	-
16	-	-	-
18	-	-	-
20	-	-	-
22	-	-	-
24	-	-	-
26	-	-	-
28	-	-	-
30	-	-	-
32	-	Ground	-

3

The bus signals are mainly connected to backplane connector 1, the module power supply is additionally connected via backplane connector 2.

Table 3.20 Pin assignments of backplane connector X2 (bottom of mass storage module)

	d	b	z
2	-	Ground	+5 V
4	-	-	-
6	Ground	-	-
8	-	-	-
10	-	-	-
12	-	-	Ground
14	-	-	/NAU
16	-	-	-
18	-	-	-
20	-	-	-
22	-	-	-
24	-	-	-
26	-	-	-
28	-	-	-
30	-	M2	M2
32	-	Ground	-

3.2.10.2 Internal, Expanded ISA Bus Connector X10

The mass storage module is connected to the basic board via the 128-pin plug X10. Please refer to Section 3.1.10.4 for the pin assignments of this plug.

3.3 AT-slot Module

The CP 581 AT-slot module does not have a direct connection to the S5 bus (back-plane bus) of a programmable controller and does not have a backplane connector. The front panel width is 1 1/3 standard slots (approx. 20 mm).

The following AT-slot module versions are available:

- 6ES5 581-0RA11 for CP 581
- 6ES5 581-0RA12 for CP 581 and CP 581/486

3.3.1 Mechanical Construction of AT-slot Module

The AT-slot module has:

- A 128-pin connector for connection to a basic board, mass storage module or AT-slot module
- An AT-bus plug for connection of a short AT-bus expansion module.

3

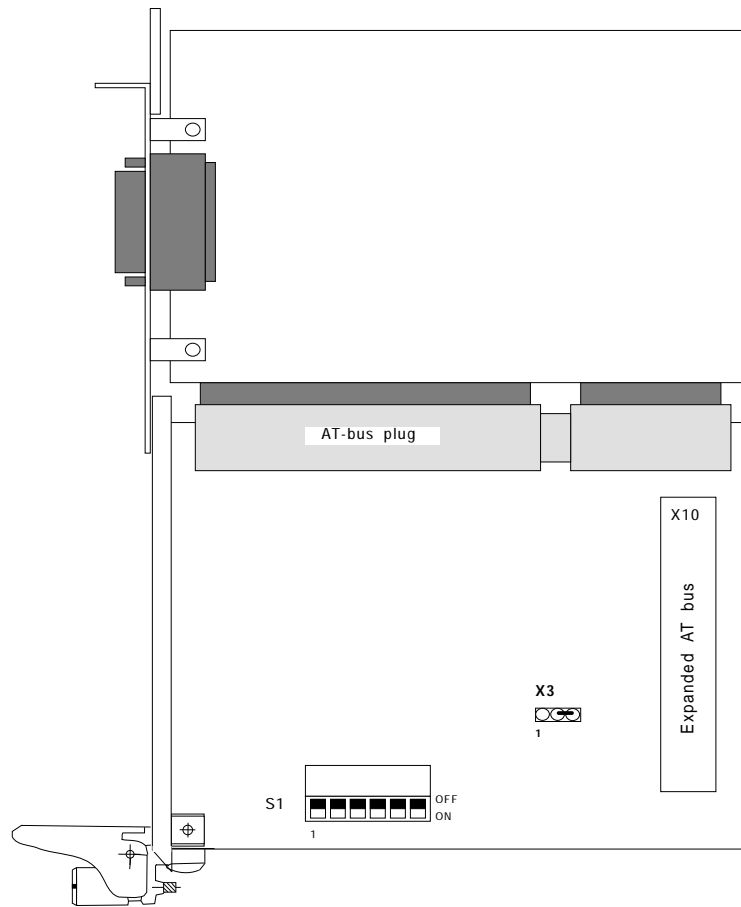

Fig. 3.8 Design of CP 581 AT-slot module (with AT extension card)

3.3.2 Switch and Jumper Settings

The coding switches and plug-in jumpers present on the AT-slot module have been factory-set.

Table 3.21 AT SLOT jumper setting/switch S1 (see Fig. 3.8)

Switch	Default setting		ON	OFF
	ON	OFF		
1		x	1)	No effect
2		x	Not allowed	
3		x	Not allowed	
4		x	Not allowed	
5		x	Not allowed	
6		x	Not allowed	

1) No effect with 6ES5 581 0RA11
I/O range > 32k disabled with 6ES5 581 0RA12

Refer to Fig. 3.8 for the positions of the switches and jumpers.

3

3.3.3 External Interface Assignments

The AT-slot module has a 98-pin standard direct plug for short AT cards (see Fig. 3.9). It has no interfaces on the front panel.

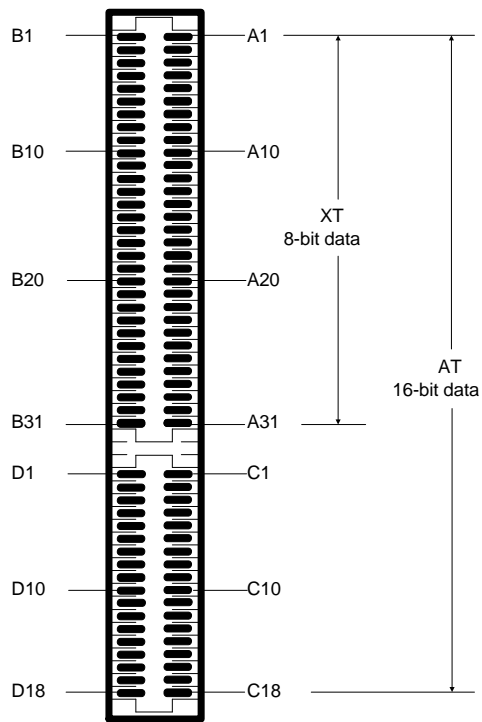

Fig. 3.9 98-pin standard direct plug

The pin assignments of the external interface are shown in the following table.

Table 3.22 Pin assignments of external interface

Pin	Signal name	Pin	Signal name
XT signals			
B1	GND	A1	I/OCHCK_N
B2	RESET DRV	A2	SD7
B3	P5V	A3	SD6
B4	IRQ9	A4	SD5
B5	N5V	A5	SD4
B6	DRQ2	A6	SD3
B7	N12V	A7	SD2
B8	0WS	A8	SD1
B9	P12V	A9	SD0
B10	GND	A10	I/OCHRDY_N
B11	SMEMW_N	A11	AEN
B12	SMEMR_N	A12	SA19
B13	I/OW_N	A13	SA18
B14	I/OR_N	A14	SA17
B15	DACK3_N	A15	SA16
B16	DRQ3	A16	SA15
B17	DACK1_N	A17	SA14
B18	DRQ1	A18	SA13

3

Pin	Signal name	Pin	Signal name
Table 3.22 cont. (2/3)			
XT signals			
B19	REFRESH	A19	SA12
B20	SYSCLK	A20	SA11
B21	IRQ7	A21	SA10
B22	IRQ6	A22	SA9
B23	IRQ5	A23	SA8
B24	IRQ4	A24	SA7
B25	IRQ3	A25	SA6
B26	DACK2_N	A26	SA5
B27	T/C	A27	SA4
B28	BALE	A28	SA3
B29	P5V	A29	SA2
B30	OSC	A30	SA1
B31	GND	A31	SA0
AT extension			
D1	MEMCS_16_N	C1	SBHE_N
D2	I/OCS16_N	C2	LA23
D3	IRQ10	C3	LA22
D4	IRQ11	C4	LA21
D5	IRQ12	C5	LA20
D6	IRQ15	C6	LA19

Pin	Signal name	Pin	Signal name
Table 3.22 cont. (3/3)			
D7	IRQ14	C7	LA18
D8	DACK0_N	C8	LA17
D9	DRQ0	C9	MEMR_N
D10	DACK5_N	C10	MEMW_N
D11	DRQ5	C11	SD8
D12	DACK6_N	C12	SD9
D13	DRQ6	C13	SD10
D14	DACK7_N	C14	SD11
D15	DRQ7	C15	SD12
D16	P5V	C16	SD13
D17	MASTER_N	C17	SD14
D18	GND	C18	SD15

3

3.3.4 Internal Interface Assignments

The connection between the AT-slot module and the basic board, mass storage module or AT-slot module is made via the ISA bus connector X10.

Please refer to Section 3.1.10.4 for the pin assignments of this plug.

3.4 Remote Terminal Interface

The remote terminal interface (RTI) enables you to use a keyboard and a mouse up to 250 m away from the CP 581. This is necessary if the CP 581 is fitted in an instrument cabinet or if the workstation is located more than 1.5 m away from the CP 581 for other reasons.

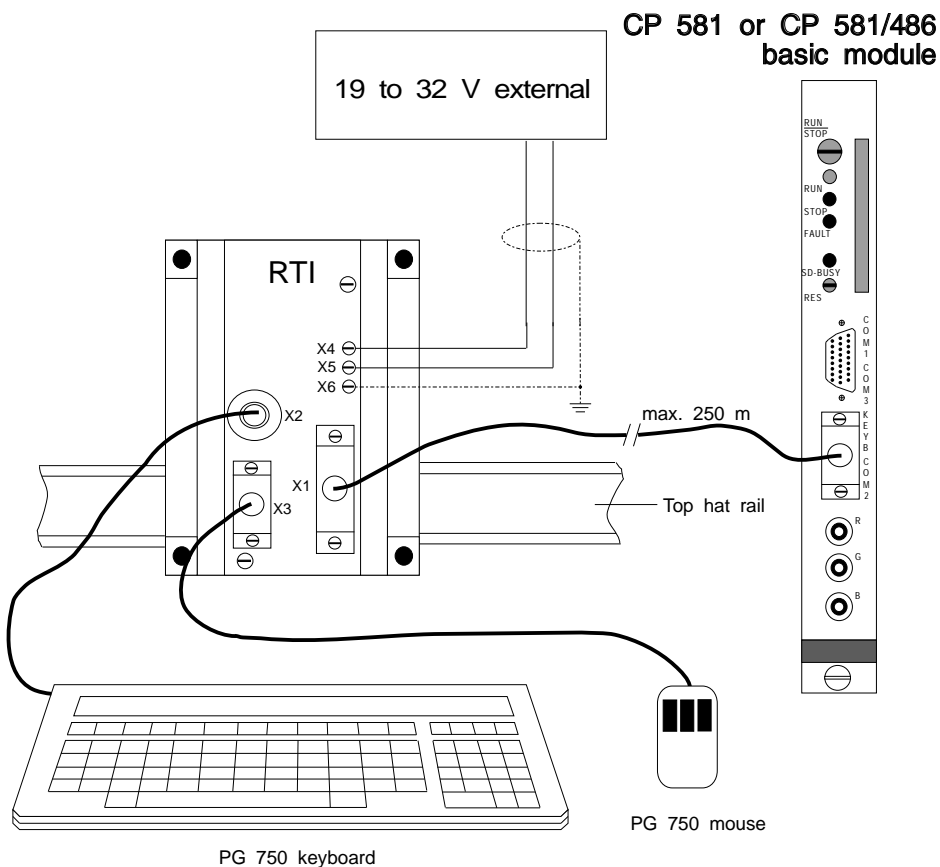

3

Fig. 3.10 CP 581 configuration with remote terminal interface with mouse

Fig. 3.10 shows you how the RTI with mouse is connected to a CP 581 or CP 581/486 basic board and the components required. These are:

- Data and power supply lines
- RTI module
- Keyboard, e.g. PG 750 keyboard
- Serial V.24 mouse.

The power supply is connected:

- For short distances (≤ 50 m) via the data line from the CP 581
- For long distances (> 50 m) by a local, external supply (DC 19 to 32 V).

Fig. 3.11 shows you how the RTI with light pen is connected to a CP 581/486 basic board and the components required. These are:

- Data and power supply lines
- RTI module
- Keyboard, e.g. PG 750 keyboard
- Light pen.

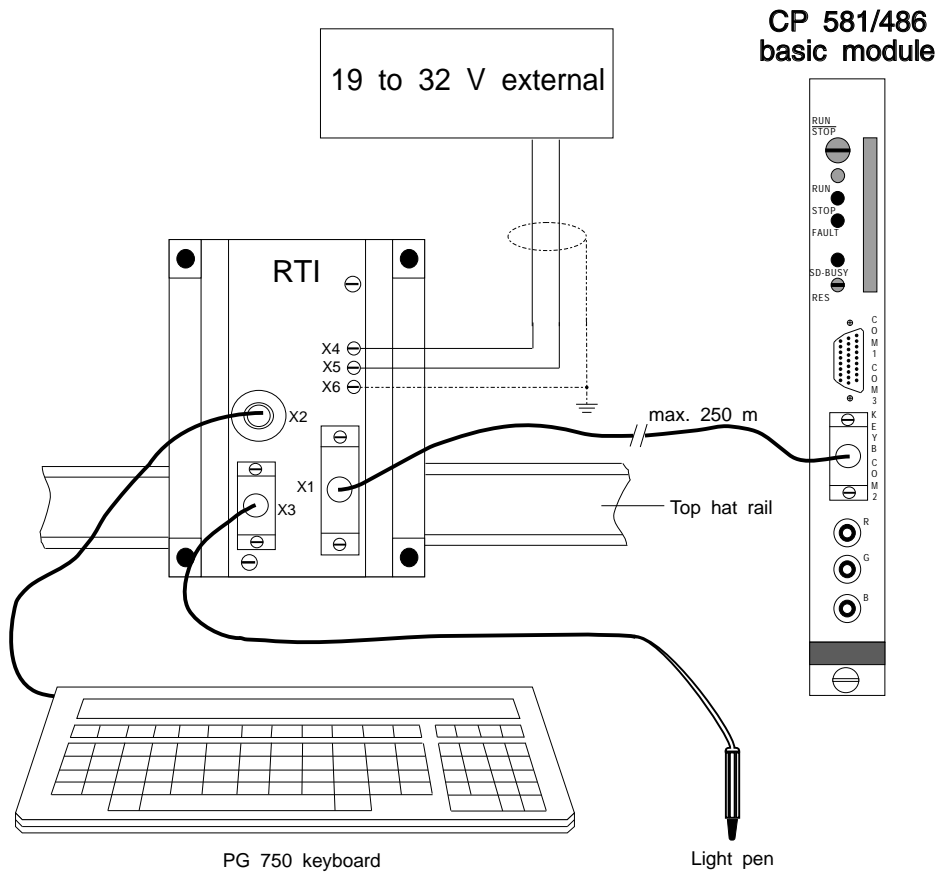

3

Fig. 3.11 CP 581/486 configuration with remote terminal interface with light pen

3.4.1 Power Supply of RTI via Remote Supply from CP 581

The voltage for the remote supply is derived from the 24-V supply of the central controller. The RTI has a floating DC/DC converter. Do not exceed the permissible current loading for the 24-V supply of the central controller.

3.4.2 Power Supply of RTI by Local, External Supply

You must provide a 24-V supply for the RTI if the distance is >50 m or if the current loading of the central controller is too high. Connect the voltage source to the provided pins X4 and X5. The polarity must be correct (see Table 3.23).

3.4.3 Connection of Keyboard to the RTI

Connect the keyboard to the X2 interface (see Fig. 3.10). We recommend the PG 750 keyboard.

3.4.4 Connection of a Mouse to the RTI

Connect the mouse to the X3 interface (see Fig. 3.10). We recommend the PG 750 mouse.



Note when using the PG 750 keyboard

Always connect the mouse to interface X3.
The mouse **must not be connected** to the PG 750 keyboard when using the RTI!

3.4.5 Connection of a Light Pen to the RTI (CP 581/486)

Connect the light pen to the RTI module interface X3 (see Fig. 3.11) and set the jumper X5 on the **RTI module** to LP (light pen).

3.4.6 Interface and Pin Assignments on the RTI

Table 3.23 RTI interface and pin assignments

Plug	Plug type	Function
X1	D25 subminiature socket	Data and power supply interface to the CP 581
X2	7-way DIN socket	Connection of PG 750 keyboard
X3	D9 subminiature socket	Mouse connection, V.24/COM 2
X4	Screw terminal	Optional supply, +19 to +32 V (pos.)
X5	Screw terminal	Optional supply, -0 V (neg.)
X6	Screw terminal	Equipotential bonding terminal/screen

3

3.4.7 Connection Cable CP 581 ↔ RTI

The connection cable has following two functions:

- Function 1:
RTI data and power supply cable, connection to KEYB/COM 2 of the CP 581 basic board.
- Function 2:
Printer cable V.24, connection to COM 1/COM 3 of the CP 581 basic board or COM 4 of the CP 581 mass storage module and printer with V.24 interface.



Note

The connections of your printer may differ from the signal assignments of the cable. Compare your printer connections with the assignments of the RTI cable (see tables below). You will find the required information in your printer manual.

- **Connection cable CP 581 ↔ RTI**

Table 3.24 Signal assignments of connection cable CP 581 ↔ RTI

CP 581, 26-pin high- density plug	Signal	RTI, D25 subminiature plug	Remarks
10	XDATA	20	Twisted pair of conductors
19	XDATA_N	03	
11	XTAKT	02	Twisted pair of conductors
20	XTAKT_N	06	
12	XGND	07	Twisted pair of conductors
21	XGND	25	
22	XRXD	18	Twisted pair of conductors
23	XRXD_N	9	
14	Not used	21	Twisted pair of conductors
15	Not used	10	
24	XTXD	14	Twisted pair of conductors
25	XTXD_N	15	
26	P24V	16	Twisted pair of conductors
18	M24V	17	
Housing	Screen	01	
8 ¹⁾	XRTS_N	23	Twisted pair of conductors
9 ¹⁾	XRTS_N	24	

¹⁾ with RTI cable 6ES5 714-1xxx1 not used

3

• **Connection cable CP 581 ↔ printer V.24**

Table 3.25 Signal assignments of connection cables CP 581 ↔ printer, V.24

CP 581, 26-pin high- density plug	Signal		Printer, D25 subminiature plug	Remarks
10	DSR	DTR	20	Twisted pair of conductors
19	TXD	RXD	03	
11	RXD	TXD	02	Twisted pair of conductors
20	DTR	DSR	06	
12	GND		07	Twisted pair of conductors
21	CTS	BUSY	25	
22	Not used		18	
23	Not used		9	
14	Not used		21	
15	Not used		10	
24	Not used		14	
25	Not used		15	
26	Not used		16	
18	Not used		17	
Housing	Screen		01	
8	Not used		23	
9	Not used		24	

3.5 Y Adapter

3.5.1 Assignments of Y Adapter Keyboard/COM 2

Table 3.26 Signal assignments of Y adapter keyboard/COM 2

CP 581, 26-pin high- density plug	Signal	Signal class	Keyboard, 7-way round socket	Mouse, ²⁾ D9 subminiature plug
1	K_DATA	Keyboard, direct	2	-
2	K_CLK	Keyboard, direct	1	-
3	P5V	Keyboard, direct	5	-
4	TxD	COM 2, V24	6	3
5	RTS	COM 2, V24	-	7
6	DTR	COM 2, V24	-	4
12	GND		4	5
13	RxD	COM 2, V24	7	2
14	CTS	COM 2, V24	-	8
15	DSR/Detect ¹⁾	COM 2, V24	-	6
16	RI/5 V ¹⁾	COM 2, V24	-	9
17	DCD/Touch ¹⁾	COM 2, V24	-	1
21	GND		3	-

¹⁾ When CP 581/486 set to light pen connection (see Section 2.8.5)

²⁾ Mouse or light pen with CP 581/486

Y Adapter

3.5.2 Assignments of Y Adapter COM 1/COM 3

Table 3.27 Signal assignments of Y adapter COM 1/COM 3

CP 581, 26-pin high- density plug	Signal	Signal class	D25 subminiature plug COM 1	D25 subminiature plug COM 3
1	RI	COM 1, V24	22	-
2	DCD	COM 1, V24	8	-
3	RTS	COM 1, V24	4	-
4	RxD+	COM 3, X27	-	11
5	RxD-	COM 3, X27	-	13
6	TxD+	COM 3, X27	-	12
7	TxD-	COM 3, X27	-	14
8	RTS	COM 3, V24	-	4
9	CTS	COM 3, V24	-	5
10	DSR	COM 1, V24	6	-
11	RxD	COM 1, V24	3	-
12	GND	COM 1, V24	7	-
13	P24V	COM 1, TTY	19	-
14	RxD+	COM 1, TTY	9	-
15	TxD+	COM 1, TTY	18	-
16	DCD	COM 3, V24	-	8

CP 581, 26-pin high- density plug	Signal	Signal class	D25 subminiature plug COM 1	D25 subminiature plug COM 3
Table 3.27 continued:				
17	DSR	COM 3, V24	-	6
18	GND	COM 3, V24	-	7
19	TxD	COM 1, V24	2	-
20	DTR	COM 1, V24	20	-
21	CTS	COM 1, V24	5	-
22	RxD-	COM 1, TTY	10	-
23	TxD-	COM 1, TTY	21	-
24	TxD	COM 3, V24	-	2
25	RxD	COM 3, V24	-	3
26	DTR	COM 3, V24	-	20

3.6 Silicon Disk

The CP 581 basic board enables you to use semiconductor memories such as a floppy disk or hard disk drive. Flash EPROMs are used as semiconductor memories which you can apply as follows:

- **As 2-Mbyte onboard silicon disk:**
This silicon disk with flash EPROMs simulates a hard disk drive from which MS-DOS can be booted and on which user programs can be stored. When using a CP 581 basic board with onboard silicon disk, it is possible to operate it without a mass storage module. A memory card is not required either.
- **As memory card:**
These memory cards simulate a floppy disk drive from which the MS-DOS operating system can also be booted. They can additionally be used for interchanging user software and user data.
Memory cards are available either with flash EPROMs or with RAMs (see Ordering Information).



Note

Note that when using a RAM card, the data you have saved on the card will be lost as soon as you remove the RAM card from the CP 581 or remove the CP 581 from the PLC rack.

3.6.1 Drive Assignments of Silicon Disks

The onboard silicon disk and the memory card are addressed by MS-DOS like conventional drives where the onboard silicon disk simulates a hard disk drive and the memory card a floppy disk drive.

When configuring the CP 581 with a basic board and a mass storage module, the BIOS of the CP 581 manages up to 4 physical drives. The logical drive designations are then as follows:

Drive designation	Data medium
A:	Floppy disk drive of mass storage module
B:	Memory card of basic board
C:	Hard disk of mass storage module
D:	Onboard silicon disk of basic board

3

The following drive designations result when operating the CP 581 basic board without a mass storage module:

Drive designation	Data medium
A:	Memory card of basic board
C:	Onboard silicon disk of basic board

3.6.2 Formatting of Silicon Disks

You must format the onboard silicon disk and the memory card just like conventional drives using MS-DOS commands.

- **Formatting of memory card:**

Before running up the CP 581, insert the memory card which is to be formatted. You can format the memory card using the following MS-DOS commands:

FORMAT x:

You must enter "A" or "B" for "x" according to the settings in SETUP (see Section 3.7). You can also use lower-case letters in the commands.

If the memory card is to be bootable, you must **additionally** enter the option **"/S"** in the format command.



Note

When running up the CP 581, the memory card which is to be formatted or another card of the same type must be inserted.

- **Formatting of onboard silicon disk:**

Proceed as follows when formatting the onboard silicon disk:

1. Create a partition on the onboard silicon disk using the MS-DOS command "FDISK".

2. Format the created partition using the following MS-DOS command:

FORMAT x: /U

You must enter "C" or "D" for "x" according to the settings in SETUP (see Section 3.7). You can also use lower-case letters in the commands.

If the partition is to be bootable, you must **additionally** enter the option **"/S"** in the format command.

3. If you wish to make the partition bootable, you must activate it by means of the MS-DOS command "FDISK" following the formatting.

3

Note

If you wish to boot from the onboard silicon disks, you must remove a hard disk on the mass storage module in the SETUP menu (see Section 3.7.2) before activating the corresponding partition, and reboot from the floppy disk drive or memory card.

You must not use the MS-DOS commands **"MIRROR"** and **"UNFORMAT"** on the silicon disks since the status prior to formatting cannot then be recreated.

3.7 SETUP

The SETUP menu consists of three pages:

- BIOS status page for entering the date and time and setting the device configuration
- BIOS S5 page for optional setting of the base interface number for data exchange with an S5 CPU

and

- BIOS option page for setting special system parameters.

You can switch between these pages using the following keys:

- Scroll forwards: **PgDn**
- Scroll backwards: **PgUp**

3

3.7.1 Starting with Default Device Configuration for the CP 581 Basic Version

In the case of the CP 581 in the configuration with basic board and mass storage module, you need only set the date and time in the SETUP (during initial starting of the CP 581 - refer to Section 2.10.1). All other system parameters are automatically set according to the default settings.

If you are using a BIOS from version V2.3 (386) or V1.3 (486) and the system software from version V2.4, please read Section 3.7.3.

3.7.2 Restart of CP 581 with Modified Device Configuration

The SETUP program is used to inform the system of device components such as memories, drives or graphic interfaces. You must carry out changes using the SETUP program if:

- You wish to operate the CP 581 in a configuration other than the default setting, e.g. basic board on its own or boot from memory card.

- The CC/EU was briefly without a power supply, and the central back-up battery of the CC/EU is flat
- A fault occurs when switching on
or
- You wish to adjust the hardware clock of the CP 581.

Carry out the SETUP as follows:

- When switching on the programmable controller:

The CP 581 attempts running-up when you switch on the programmable controller. If the backing-up of the SETUP data was interrupted, the following message appears on the screen:

**MEMORY SIZE HAS CHANGED SINCE LAST BOOT
CMOS CHECKSUM ERROR - DEFAULTS LOADED
CMOS BATTERY HAS FAILED
CHIPSET CFG CORRUPT - DEFAULTS LOADED**

You now have two possibilities:

- a) Boot with the default values by pressing key F1.
- b) Start the SETUP program by pressing the key combination

CTRL and **ALT** and **ESC**

- Call SETUP program from the MS-DOS level:

You can call the SETUP program from the MS-DOS level in the following manners:

- a) When using a CP 581 with BIOS version < 2.0:
Enter the command **EXSETUP**.
- b) When using a CP 581 with BIOS version 2.0 or upwards or when using the CP 581/486:
You can call the SETUP program at any time by entering the key combination

CTRL and **ALT** and **ESC**

The EXSETUP program will no longer be needed.
If it is still present on your hard disk, you should erase it.

3

- c) Regardless of the BIOS version and the CP 581 version:
You can carry out a warm restart by entering the key combination:

CTRL and **ALT** and **DEL**

Following the power-on selftest, press the keys:

CTRL and **ALT** and **ESC**

- A form appears on the screen in which you can carry out the SETUP settings. Fig. 3.10 shows you the default values when the form is displayed.
- You can now access the required input field using the **cursor keys** and carry out the settings or select the options using the **"+/-" keys or the cursor keys of the numeric keypad**.

- Table 3.28 shows which settings you can make. Once you have made the settings according to your device configuration, press key F10 and then key F5 to save the values.
To abort the inputs made in the SETUP form without saving the modified parameters, press key F10 and then key F1.

Date: 09 June 1992	*) 80x86SL ISA BIOS SIEMENS SIMATIC CP 581 VERSION x.x
Time: 00:00:00	
Drive A: 1.44 M, 3 1/2 in.	Base Memory: 640k Extended Memory: 3072k Expanded Memory: 0k Other Memory: 384k ----- Total Memory: 4096k
Drive B: None	
Video: EGA/VGA	Security: Disable
Post Messages: Maximize	
Quick Boot: Disable	
Halt On: No Errors	
Boot Sequence A,C	
Auto Detect IDE Drive C:	

		CYLS.	HEADS	SECTORS	PRECOMP	LANDZONE
Drive C:	IDE (116 MB) **)	762	8	39	None	761
Drive D:	None (0 MB)	0	0	0	0	0

Alt-F1 for Menu Help	PgDn = S5 Page	F10 exits
Page 01: Status Page		F2 change colors

*) CP 581 : x = 3 CP 581/486 : x = 4

**) The values depend on the drive used. When the CP 581 is delivered the values are entered correctly. Note down the values in the screen form so you can enter them again if the data is lost following a crash.

Fig. 3.12 SETUP form (BIOS status page) with default settings

Table 3.28 Parameters and default settings of the BIOS status page

Input field	Possible inputs	Description
Date	-	Date
Time	-	Time
Drive A:	1.44 MB 3.5 " *	Floppy disk drive on mass storage module
	Flash card	Flash card on basic board
	RAM card	RAM card
	None	
Drive B:	Flash card	Only permissible if "Drive A:" is set as 1.44-Mbyte floppy disk drive
	RAM card	
	None *	
Video	EGA/VGA *	
Post Messages	Maximize *	All messages are displayed
	Minimize	Only error messages and other important messages are displayed
Quick Boot	Disable *	Maximum memory test in POST
	Enable	Minimum memory test in POST
Halt On	Selection of which non-fatal errors during the power-on selftest (POST) are to lead to a system stop	
	All errors	All errors
	No errors *	No errors
	All but diskette	All except floppy disk errors
	All but keyboard	All except keyboard errors
	All but disk/key	All except floppy disk and keyboard errors

3

Input field	Possible inputs	Description
Table 3.28 continued:		
Boot Sequence	A,C *	First drive A:, then C:
	C,A	First drive C:, then A:
Auto Detect IDE	Switch automatic IDE drive parameter detection on/off	
	Drive C: *	Recommended setting
	Drive D:	
	Both C: and D:	
	Disabled	
Drive C:	<Type>	Drive type 1 to 49
	IDE *	Automatic detection of drive parameters
	None	
	OSD	Select this setting if you wish to boot from the onboard silicon disk
Drive D:	None *	
	OSD	Onboard silicon disk (internal type 50) This setting is only permissible if a hard disk drive is set as "Drive C:"
Security:	Enables access to the system and to SETUP protected by password	
	Disable *	Free access
	SETUP access	Protected access to SETUP
	System access	Protected access to system and to SETUP

The default settings are identified by a *. These are loaded following failure of the back-up voltage.

3.7.3 Restart of CP 581 with Memory Function for the SETUP Setting

This information contained in this section covers

- BIOS from version V2.3 (386) or V1.3 (486)
- System software from version V2.4

Running SETUP:

After switching on the PLC, the CP 581 runs up without being interrupted by a screen message even if the backing up of the SETUP data (in CMOS-RAM) is interrupted. During this process BIOS enters the following default settings in the SETUP:

- **with** mass storage module: A: = Floppy Disk; C: = IDE Hard Disk
- **without** mass storage module: A: = Flash Card; C: = OSD
- On the BIOS-S5 page: S5-Interface: Disable

3

Storing the SETUP settings:

After running up the CP 581, store the current SETUP settings (**actual** settings) in a file. To do this enter the following command from the MS-DOS level

```
SAVECMOS <name> e.g., SAVESMOS c:setup1.bin
```

Running SETUP and the comparing the actual settings with the stored SETUP settings:

It is assumed that the SETUP settings are already stored in a file using SAVECMOS. After switching on the PLC, the CP runs up as described above. After this you can compare the actual SETUP settings with the SETUP settings stored in a file.

To do this enter the MS-DOS command

INITCMOS <name> e.g., c:setup1.bin.

If the comparison of the setpoint settings and actual settings **do not** agree, the setpoint settings are transferred to the CMOS-RAM as the actual settings and the CP is restarted.

If the settings **do** agree, the current SETUP settings are retained and no warm restart is performed.

Note



- If you enter the command INITCMOS <name> in the AUTOEXEC.BAT file, a comparison with the setpoint settings in the "name" file is done following every CP start-up.

- The default setting "S5-Interface: Disable" prevents uncontrolled access of the S5 bus when you first install the CP.

You should only enable the S5 interface using the SETUP setting "S5-Interface: Enable" when you have decided on the final SETUP start-up.

- Calling SETUP from the MS-DOS level and changing the SETUP settings - as described in Section 3.7.2 - is still possible.

- An existing file with the setpoint settings from the SETUP can be overwritten by saving using the command SAVECMOS <name> with the current SETUP parameters.

3.7.4 BIOS S5 Page

You can access the BIOS S5 page menu (see Fig. 3.13) from the BIOS status page using the key "PgDn".

Here you can enter the base interface number for data exchange with the S5 CPUs in the field "Number". You need not enter anything in this menu if you use the option "SSNR" in the load command for the CPDHB driver (please refer to Volume 2 of the manual).

CONTROL		COMMUNICATION FLAGS	
S5-Interface:	Enable	0 - 31 F200H-F21FH:	Disable
Page frames:	Enable	32 - 63 F220H-F23FH:	Disable
I/O-Pointer:	Disable	64 - 95 F240H-F25FH:	Disable
Pointer read:	Disable	96 - 127 F260H-F27FH:	Disable
PAGE FRAMES		128 - 159 F280H-F29FH:	Disable
Frames:	4	160 - 191 F2A0H-F2BFH:	Disable
Mode:	Paged	192 - 223 F2C0H-F2DFH:	Disable
Page Number:	0	224 - 255 F2E0H-F2FFH:	Disable
Base:	F400		
I/O-POINTER			
Range:	P-Periphery		
Base:	F000H		
Alt-F1 for Menu Help		PgUp = Status Page	F10 exits
Page 02: S5 Page		PgDn = Options Page	F2 change colors

3

Fig. 3.13 BIOS S5 page with default settings

The default settings are identified in the following tables by a *. These are loaded following failure of the back-up voltage.

Control

Table 3.29 Parameters and default settings with BIOS S5 page: control

Input field	Possible inputs	Description
S5-Interface	Disable ¹⁾	Access via S5 bus completely disabled
	Enable ¹⁾	Access via S5 bus completely enabled
Page frames	Disable	Access of page frames via S5 bus disabled
	Enable *	Access of page frames via S5 bus enabled
I/O-Pointer	Disable *	I/O-mapped access operations disabled
	Enable	I/O-mapped access operations enabled
Pointer read	Disable *	Reading of I/O address pointers disabled
	Enable	Reading of I/O address pointers enabled

1) Default setting: Disable from BIOS version V2.3 (386) and from V1.3 (486), see Section 3.7.3, Enable from BIOS versions prior to V2.3 (386) and prior to V1.3 (486).

Page frame

Table 3.30 Parameters and default settings with BIOS S5 page: page frame

Input field	Possible inputs	Description
Frames	1, 2, 4*, 8	Number of pages ¹⁾
Mode	Paged *	Access operations via the S5 bus take place in page mode
	Linear	Access operations via the S5 bus take place with linear addressing
Page Number	0 – 255 (modulo FRAMES)	Base interface number (default setting 0)
Base	0000 – FC00H (modulo 400H)	Page base address (default setting F400H)

3

¹⁾ If you use the system software of the CP 581, you may only enter the value "4" here.

I/O pointer

Table 3.31 Parameters and default settings with BIOS S5 page: I/O pointer

Input field	Possible inputs	Description
Range	P area *	Initial address of I/O-mapped periphery points to the P area (F000H - F0FFH)
	O area	Initial address of I/O-mapped periphery points to the O area (F100H - F1FFH)
Base	0 – 255 (modulo 8)	Base address for I/O-mapped access (default setting 0)

Communication flags

Table 3.32 Parameters and default settings with BIOS S5 page: communication flags

Input field	Flag	Possible inputs
F200-F21F	0 – 31	Disable *
		Enable
F220-F23F	32 – 63	Disable *
		Enable
F240-F25F	64 – 95	Disable *
		Enable
F260-F27F	96 – 127	Disable *
		Enable
F280-F29F	128 – 159	Disable *
		Enable
F2A0-F2BF	160 – 191	Disable *
		Enable
F2C0-F2DF	192 – 223	Disable *
		Enable
F2E0-F2FF	224 – 255	Disable *
		Enable

3.7.5 BIOS Options Page (CP 581)

You can reach the BIOS option page menu (Fig. 3.14) from the menu "BIOS S5 page" using the key "PgDn". You can set special system parameters in this menu.

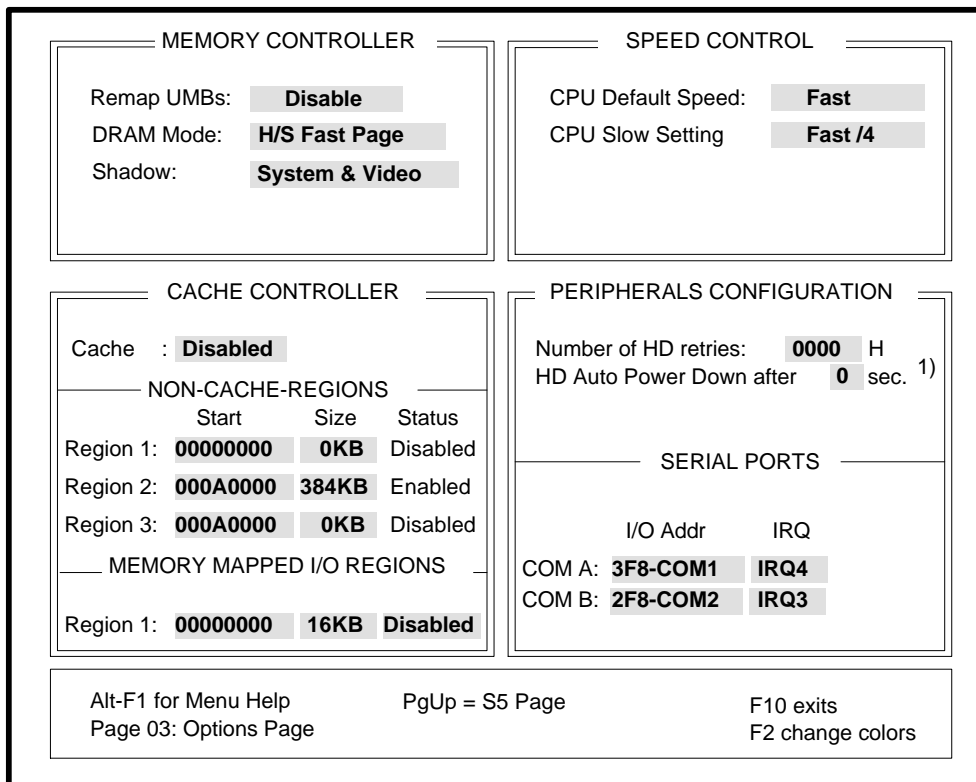

3

¹⁾ BIOS version 2 upwards

Fig. 3.14 BIOS options page with default settings

The default settings are identified in the following tables by a *. These are loaded following failure of the back-up voltage.

Memory controller

Table 3.33 Parameters and default settings with BIOS options page: memory controller

Input field	Possible inputs	Description
Remap UMBs	Enabled	Unused upper memory blocks of the shadow memory are used as an expanded memory (>1 Mbyte)
	Disable *	Switching-off of above setting
DRAM mode	Selection of DRAM access mode for system memory	
	Page	
	H/S fast page *	H/S = high speed
	Fast page	
Shadow	Switching-on of shadow RAM for system and video ROMs	
	Disabled	No shadow RAM
	System	Shadow for F0000H - FFFFFH
	Video	Shadow for C0000H - C7FFFH
	System & video *	Shadow for both

Cache controller

Table 3.34 Parameters and default settings with BIOS options page: cache controller

Input field	Possible inputs	Description
Cache	The cache must only be switched on when the cache RAM is present, i.e. when the expanded memory is inserted	
	Disabled *	Cache switched off
	Direct mapped	
	2-way set	(associative)
	4-way set	(associative)

Input field	Possible inputs	Description
Table 3.34 cont. (2/3)		
Non-cache regions		
Region 1/Start	00000000 – 00090000 (0 – 576 K) in 64-K steps Default: 00000000 *	Start address (hexadecimal number) of a memory region in the 1st Mbyte which is not cached.
Region 1/Size	64 K – 640 K in 64-K steps Default: 0 *	Size of non-cached memory region; a size of zero switches off the region.
Region 2/Start	000A0000 – 000FC000 (0 – 576 K) in 64-K steps Default: 00000000 *	Start address (hexadecimal number) of a memory region in the 1st Mbyte which is not cached.
Region 2/Size	16 K – 384 K in in 16-K steps Default: 384 *	Size of non-cached memory region; a size of zero switches off the region.
Region 3/Start	000A0000 – 000FC000 (0 – 576 K) in 64-K steps Default: 00000000 *	Start address (hexadecimal number) of a memory region in the 1st Mbyte which is not cached.
Region 3/Size	16 K – 384 K in in 16-K steps Default: 0 *	Size of non-cached memory region; a size of zero switches off the region.
Memory mapped I/O regions		
Region 1/Start	1 – 32 Mbyte in 32-K steps Default: 0 *	Start address (hexadecimal number) of a memory-mapped I/O region; access operations to this are routed to the ISA bus and not cached.

Input field	Possible inputs	Description
Table 3.34 cont. (3/3)		
Region 1/Size	4 K, 8 K, 16 K * or 32 K	Size of memory-mapped I/O region
Region 1/Status	Enabled or disabled *	Switches the memory-mapped I/O region on or off

Speed control

Table 3.35 Parameters and default settings with BIOS options page: speed control

Input field	Possible inputs	Description
CPU Default Speed	System speed following booting	
	Fast *	Fast
	Slow	Set as for "CPU Slow Setting"
CPU Slow Setting	Fast	As for "CPU Default Speed"
	Fast/2	
	Fast/4 *	
	Fast/8	

Peripherals configuration

Table 3.36 Parameters and default settings with BIOS options page: peripherals configuration

Input field	Possible inputs	Description
Number of HD retries	0000H * – FFFFH	Number of retries in event of faulty hard disk access
HD Auto Power Down		
Time	0 * 60 65 70 . . 995 1000	Disabled If the hard disk is not addressed within the preset time it will switch to the standby mode (motor off).
Serial ports		
COM A – I/O Addr	3F8h-COM1 * (IRQ4)	I/O address of serial port (COM) A
	2F8h-COM2 (IRQ3)	
	Disabled	Serial port (COM) A off
COM A – I/O IRQ	IRQ 3, 4 *, 10, 11, 12 or 15	Caution! Avoid collision with the IRQ setting of COM 3/4! ¹⁾
COM B – I/O Addr	3F8h-COM1 (IRQ4)	I/O address of serial port (COM) B
	2F8h-COM2 * (IRQ3)	
	Disabled	Serial port (COM) B off
COM B – I/O IRQ	IRQ 3 *, 4, 10, 11, 12 or 15	Caution! Avoid collision with the IRQ setting of COM 3/4! ¹⁾

3

¹⁾ The IRQ setting of COM 3/4 is described in Section 3.1.10.2.



Note

If you insert a memory extension (containing cache RAM) you must explicitly switch on the cache in the "BIOS options page".

"COM A" is labelled "COM 1", "COM B" is labelled "COM 2" on the CP 581.

3.7.6 BIOS Options Page (CP 581/486)

<p style="text-align: center; border-top: 1px solid black; border-bottom: 1px solid black;">MEMORY CONTROLLER</p> <p>Remap UMBS: Disable</p> <p>Shadow: System & Video</p>	<p style="text-align: center; border-top: 1px solid black; border-bottom: 1px solid black;">SPEED CONTROL</p> <p>CPU Default Speed: Fast</p> <p>CPU Slow Setting Fast /4</p>						
<p style="text-align: center; border-top: 1px solid black; border-bottom: 1px solid black;">CACHE CONTROLLER</p> <p>Cache : Disabled</p>	<p style="text-align: center; border-top: 1px solid black; border-bottom: 1px solid black;">PERIPHERALS CONFIGURATION</p> <p>Number of HD retries: 0000 H</p> <p>HD Auto Power Down after 0 sec.</p>						
<p style="text-align: center; border-top: 1px solid black; border-bottom: 1px solid black;">SERIAL PORTS</p> <table style="width: 100%; border-collapse: collapse;"> <thead> <tr> <th style="text-align: left; border-bottom: 1px solid black;">I/O Addr</th> <th style="text-align: left; border-bottom: 1px solid black;">IRQ</th> </tr> </thead> <tbody> <tr> <td>COM A: 3F8-COM1</td> <td>IRQ4</td> </tr> <tr> <td>COM B: 2F8-COM2</td> <td>IRQ3</td> </tr> </tbody> </table>		I/O Addr	IRQ	COM A: 3F8-COM1	IRQ4	COM B: 2F8-COM2	IRQ3
I/O Addr	IRQ						
COM A: 3F8-COM1	IRQ4						
COM B: 2F8-COM2	IRQ3						
<table style="width: 100%; border-collapse: collapse;"> <tr> <td style="width: 33%;">Alt-F1 for Menu Help</td> <td style="width: 33%;">PgUp = S5 Page</td> <td style="width: 33%;">F10 exits</td> </tr> <tr> <td>Page 03: Options Page</td> <td></td> <td>F2 change colors</td> </tr> </table>		Alt-F1 for Menu Help	PgUp = S5 Page	F10 exits	Page 03: Options Page		F2 change colors
Alt-F1 for Menu Help	PgUp = S5 Page	F10 exits					
Page 03: Options Page		F2 change colors					

3

Fig. 3.15 BIOS options page with default settings

Memory controller

Table 3.37 Parameters and default settings with BIOS options page: memory controller

Input field	Possible inputs	Description
Remap UMBs	Enabled	Unused upper memory blocks of the shadow memory serve as expanded memory (> 1 Mbyte)
	Disable *	Switching-off of above setting
Shadow	Switching-on of shadow RAM for system and video ROMs	
	Disabled	No shadow RAM
	System	Shadow for F0000H – FFFFFH
	Video	Shadow for C0000H – C7FFFH
	System & Video *	Shadow for both

Cache controller (CP 581/486)

Table 3.38 Parameters and default settings with BIOS options page: cache controller

Input field	Possible input	Description
Cache	ENABLE *	486-internal cache to be used
	DISABLE	486-internal cache not to be used

Speed control

Table 3.39 Parameters and default settings with BIOS options page: speed control

Input field	Possible inputs	Description
CPU Default Speed	System speed following booting	
	Fast *	Fast
	Slow	Set as for "CPU Slow Setting"
CPU Slow Setting	Fast	As for "CPU Default Speed"
	Fast/2	
	Fast/4 *	
	Fast/8	

3

Peripherals configuration

Table 3.40 Parameters and default settings with BIOS options page: peripherals configuration

Input field	Possible inputs	Description
Number of HD retries	0000H * – FFFFH	Number of retries in event of faulty hard disk access
HD Auto Power Down		
Time	0 * 60 65 70 . . 995 1000	Disabled If the hard disk is not addressed within the preset time it will switch to the standby mode (motor off).

Input field	Possible inputs	Description
Table 3.40 continued:		
Serial Ports		
COM A – I/O Addr	3F8h-COM1 * (IRQ4)	I/O address of serial port (COM) A
	2F8h-COM2 (IRQ3)	
	Disabled	Serial port (COM) A off
COM A – I/O IRQ	IRQ 3, 4 *, 10, 11, 12 or 15	Caution! Avoid collision with the IRQ setting of COM 3/4! ¹⁾
COM B – I/O Addr	3F8h-COM1 (IRQ4)	I/O address of serial port (COM) B
	2F8h-COM2 * (IRQ3)	
	Disabled	Serial port (COM) B off
COM B – I/O IRQ	IRQ 3 *, 4, 10, 11, 12 or 15	Caution! Avoid collision with the IRQ setting of COM 3/4! ¹⁾

¹⁾ The IRQ setting of the COM 3/4 is described in Section 3.1.10.2.

	<p>Note</p> <hr/> <p>"COM A" is labelled "COM 1" on the CP 581 and "COM B" is labelled "COM 2" .</p>
---	---

3.8 Conversion and Repairs



Note

Do not carry out any conversions apart from those described in Chapter 2!

Repairs must only be carried out by Siemens or by companies authorized by Siemens.

3.9 Information for Developers of Own System Software

This section contains information for users who only use the CP 581 hardware and wish to develop their own system software and/or drivers.

3.9.1 S5 Interface

Hardware structure

CC00:4000	
CC00:3FE0	Control register
	Not used
CC00:2300	
CC00:2200	Communication flag
	Not used
CC00:2100	
CC00:2000	I/Os
	Page 7
CC00:1C00	
	Page 6
CC00:1800	
	Page 5
CC00:1400	
	Page 4
CC00:1000	
	Page 3
CC00:0C00	
	Page 2
CC00:0800	
	Page 1
CC00:0400	
	Page 0
CC00:0000	

Fig. 3.16 Memory assignment of S5 interface

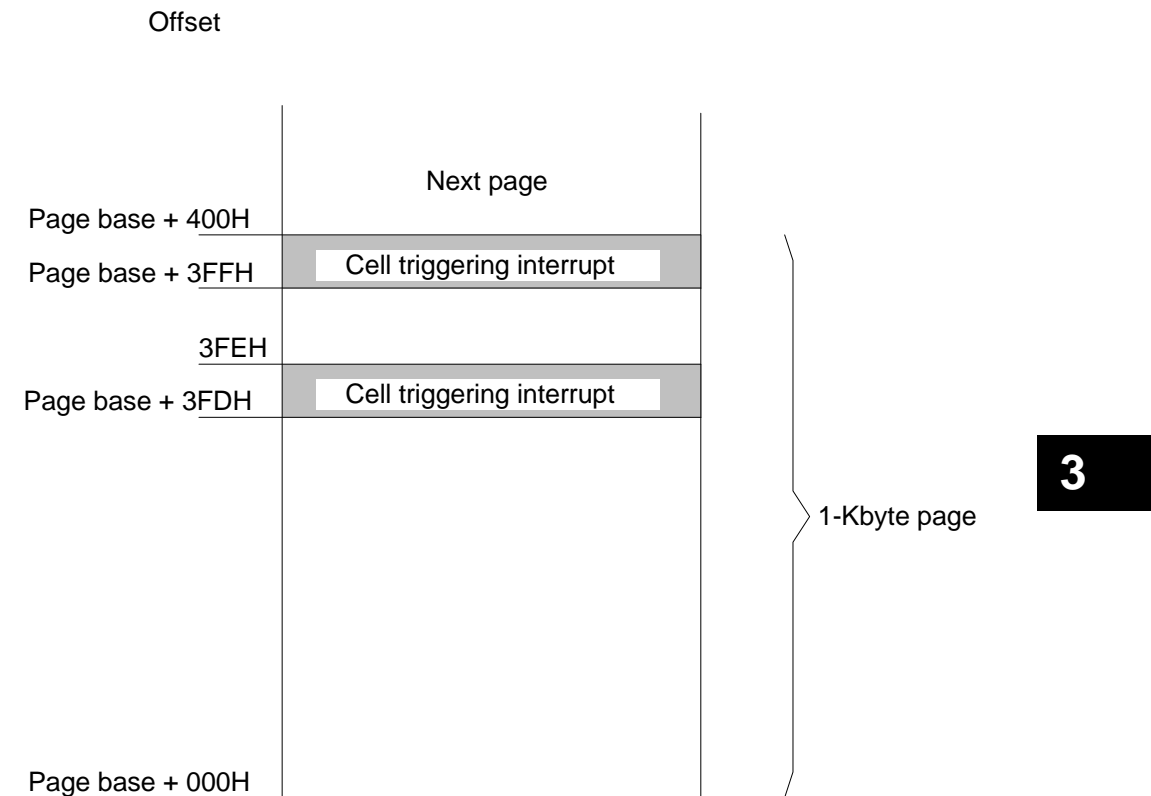

Fig. 3.17 Interrupt triggering with S5 interface

Each page has two interrupt-triggering cells. A status bit in the interrupt **status** register is assigned to each of these cells (see Fig. 3.17). The associated status bit is set when writing the S5 CPU into one of these cells.

An enable bit is assigned to each page in the interrupt **enable** register. Only if the enable bit of a page is set can its interrupts reach the IRQ 15 line and thus trigger an interrupt.

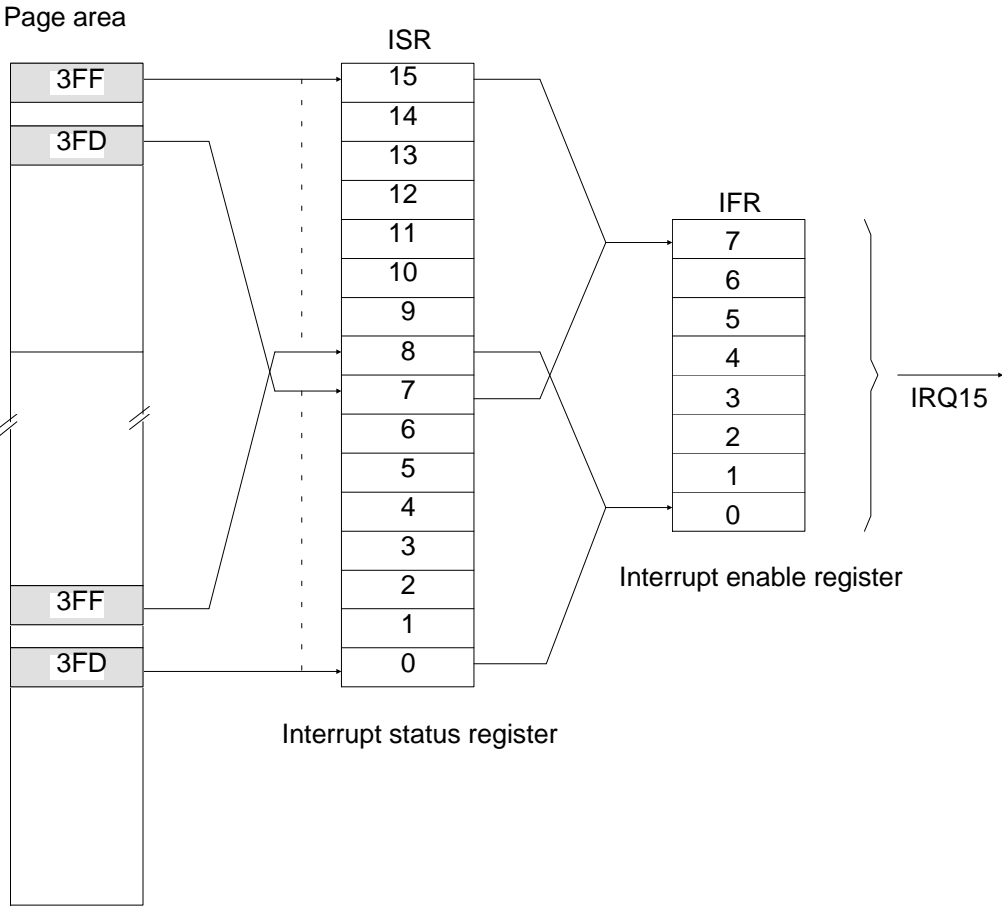

Fig. 3.18 Interrupt register with S5 interface

Initialization

Global enable for S5 interface
Write port 5007H

Bit No.								Meaning	
7	6	5	4	3	2	1	0		
No significance								1	Switch on S5 interface
No significance								0	Switch off S5 interface

3

S5 bus parameters (S5 control register (CTLS5))

Read/write memory CC00:3FEO

Bit No.																
15	14	13	12	11	10	9	8	7	6	5	4	3	2	1	0	
No significance				SB				S5EN	IOEN	KEN	LIEN	EPB	AZR	KA		

KA Determines the number of pages

KA		Number of pages
0	0	1
0	1	2
1	0	4 (default with reset)
1	1	8

AZR AZR = 0 means that reading of the I/O address pointers (IOAZ 0 - 3) is disabled. Reading is enabled with AZR = 1. (AZR = 1 is the default setting with reset.)

EPB Determines the initial address for the I/O mapped periphery.

EPB	Initial address
0	P area (F000H - F0FFH)
1	O area (F100H - F1FFH) (default with reset)

LIEN LIEN = 0 means that access is via the S5 bus in page mode. LIEN = 1 means that access is with linear addressing. (LIEN = 0 is the default setting with reset.)

KEN KEN = 0 means that page access via the S5 bus is disabled. This is enabled with KEN = 1. (KEN = 1 is the default setting with reset.)

IOEN IOEN = 0 means that I/O-mapped periphery access is disabled. It is enabled with IOEN = 1. (IOEN = 1 is the default setting with reset.)

S5EN S5EN = 0 means that access via the S5 bus is completely disabled. It is enabled with S5EN = 1. (S5EN = 1 is the default setting with reset.)

SB0 – SB3 SB0 - SB3 has no hardware function. SB0 - SB3 can also be read by the S5 bus by means of a read operation at one of the address pointers IOAZ0 - IOAZ3. (Assumption: status information can be passed on to the S5 in this manner.)

AT bus parameters (ISA control register (CTLISA))

Read/write memory CC00:3FE2

Bit No.															
15	14	13	12	11	10	9	8	7	6	5	4	3	2	1	0
No significance					ZEN	MEN	CS16	WS	TWD	WZEN	WOEN	WD0	L2	L1	L0

- L0 L0 = 1 switches the RUN LED on. L0 = 0 switches it off.
- L1 L1 = 1 switches the STOP LED on. L1 = 0 switches it off.
- L2 L2 = 1 switches the SD BUSY LED on. L2 = 0 switches it off.
- WD0 WD0 is valid if WOEN = 1 is set.
In this case WD0 indicates the status of the watchdog.
This has expired if WD0 = 1, or not yet expired if WD0 = 0.
- WOEN WOEN = 1 means that the watchdog output is enabled.
It is disabled if WOEN = 0.
- WZEN WZEN = 1 means that the watchdog counter is enabled.
It is disabled if WZEN = 0.
- TWD TWD = "1" means that the watchdog counter is loaded with the
contents of the watchdog register and restarted.
- WS WS = 1 means that an additional wait cycle is inserted when
accessing the dual-port RAM. WS can be set to 0.
- CS16 CS16 = 1 means that access to the S5 interface is in 16-bit
mode. Access is in 8-bit mode with CS16 = 0.
CS16 can only be read. 8-bit mode is fixed for the CP 581.



MEN MEN = 0 means that access to the dual-port RAM is disabled at the AT end. It is enabled with MEN = 1.

ZEN ZEN = 1 means that the counter interface is enabled. It is disabled with ZEN = 0.

Page parameter register (KAPA)

Read/write memory CC00:CFE4

Bit No.															
15	14	13	12	11	10	9	8	7	6	5	4	3	2	1	0
KABA						No significance		SSNR							

SSNR SSNR defines the base interface number under which the first page is addressed. If further pages are defined, these are located directly after the first page and occupy the following interface numbers according to their quantity.

KABA KABA determines the page base address under which the page is addressed on the S5 bus. Bit 15 represents address A15, bit 14 represents address A14 etc.
 Example: 111101 results in the S5 bus address F400H (this value is required for the DHB).
 111101 is the default setting following a reset.

Communication flag register (KOME)

Read/write memory CC00:3FE6

Bit No.															
15	14	13	12	11	10	9	8	7	6	5	4	3	2	1	0
No significance								KM							

KM

KM determines which communication flags are present in the dual-port RAM of the CP 581. The following table describes the addresses and flag numbers assigned to the respective bits.

3

Bit No. *	Address in CP 581 communication flag area	Flags	S5 addresses
0	CC00:2200 – CC00:221F	0 – 31	F200H – F21FH
1	CC00:2220 – CC00:223F	32 – 63	F220H – F23FH
2	CC00:2240 – CC00:225F	64 – 95	F240H – F25FH
3	CC00:2260 – CC00:227F	96 – 127	F260H – F27FH
4	CC00:2280 – CC00:229F	128 – 159	F280H – F29FH
5	CC00:22A0 – CC00:22BF	160 – 191	F2A0H – F2BFH
6	CC00:22C0 – CC00:22DF	192 – 223	F2C0H – F2DFH
7	CC00:22E0 – CC00:22FF	224 – 255	F2E0H – F2FFH
* KM 1: enable / KM 0: disable			

Auxiliary port (BIO)

Read/write memory CC00:3FEA

Bit No.																
15	14	13	12	11	10	9	8	7	6	5	4	3	2	1	0	
RES	RES	FAU LT	RES	No significance				BIOCONF								

BIOCONF BIOCONF is initialized by the CP 581 BIOS with 01010101B.

RES Spare output.

FAULT FAULT = 0 means that the FAULT LED lights up;
it is off with FAULT = 1.

Watchdog register

The watchdog timeout is set by a write operation at this register. The read operation indicates the current value of the watchdog timer. The accuracy of the watchdog is 256 μ s.

Read/write memory CC00:3FF0

Reset state: High byte = 1111 1111
 Low byte = 1111 1111

Bit No.															
15	14	13	12	11	10	9	8	7	6	5	4	3	2	1	0
High byte								Low byte							

High byte: Write:
 High byte of timeout

 Read:
 High byte of watchdog timer

Low byte: Write:
 Low byte of timeout

 Read:
 Low byte of watchdog timer

3

3.9.2 Interrupt Processing on S5 Interface

Interrupt status register 1

Read/write memory CC00:3FF2

Bit No.															
15	14	13	12	11	10	9	8	7	6	5	4	3	2	1	0
KIF								KID							

KIF0 – KIF7 Interrupt from page i triggered at the page offset address 3FFH

KID0 – KID7 Interrupt from page i triggered at the page offset address 3FDH

	<p>Note</p> <hr/> <p>The interrupts are acknowledged by writing a "1" at the bit position to be acknowledged.</p>
---	--

Interrupt status register 2

Read/write memory CC00:3FF4

Bit No.															
15	14	13	12	11	10	9	8	7	6	5	4	3	2	1	0
No significance										S	R	WDI	ZI	SI	RI

- RI RI = 1 means that an interrupt has been triggered by the RUN/STOP switch. The switch is changed in the process from STOP to RUN.
- SI SI = 1 means that an interrupt has been triggered by the RUN/STOP switch. The switch is changed in the process from RUN to STOP.
- ZI ZI = 1 means that an interrupt has been triggered by the counter. A new counted value can be read in the counter register.
- WDI WDI = 1 means that an interrupt has been triggered by the expired watchdog.
- R R = 1 means that the RUN/STOP switch is in the RUN position.
- S S = 1 means that the RUN/STOP switch is in the STOP position.

3

	<p>Note</p> <hr/> <p>The interrupts are acknowledged by writing a "1" at the bit position to be acknowledged.</p>
---	--

Interrupt enable register

Read/write memory CC00:3FF6

Bit No.															
15	14	13	12	11	10	9	8	7	6	5	4	3	2	1	0
IEG	No significance				IEZ	IEWD	IERS	IEK							+

- IEK0 – IEK7 With IEKi = 1, the interrupts are enabled by page i (offset 3FDH and 3FFH); the interrupts are disabled with iEKi = 0.
- IERS IERS = 1 means that RUN/STOP switch interrupts are enabled; they are disabled with IERS = 0.
- IEWD IEWD = 1 means that watchdog interrupts are enabled; they are disabled with IEWD = 0.
- IEZ IEZ = 1 means that counter interrupts are enabled; they are disabled with IEZ = 0.
- IEG IEG = 1 means that the interrupts are all enabled; they are disabled with IEG = 0.

S5 bus interrupts

Port	Bit No.								Meaning	
	7	6	5	4	3	2	1	0		
Write 5001H	No significance								1	Activate INT A
	No significance								0	Deactivate INT A
Write 5002H	No significance								1	Activate INT B
	No significance								0	Deactivate INT B
Write 5003H	No significance								1	Activate INT C
	No significance								0	Deactivate INT C
Write 5004H	No significance								1	Activate INT D
	No significance								0	Deactivate INT D

3

3.9.3 Other Status Registers

Battery failure indication

Read port 5000H

Bit No.								Meaning	
7	6	5	4	3	2	1	0		
No significance								1	Battery failure
No significance								0	No battery failure

Power supply failure indication

Read port 5001H

Bit No.								Meaning	
7	6	5	4	3	2	1	0		
No significance								1	No power supply failure
No significance								0	Power supply failure

3.9.4 Peripheral Byte Addressing

The I/O byte access implemented by the CP 581 is an indirect type of addressing for which a memory area of 256 bytes is available. Access is via an address pointer **IOAZ (3:0)** and the associated data register **IODR (3:0)**. Both have a data word width of 8 bits.

A write operation on the address pointer sets the byte offset address provided for the I/O operation. A byte value can be read or written via the data register. Four sets of these registers exist (see Fig. 3.16).

An operation is carried out if the S5 address is in the 256-byte I/O area (0xF000 to 0xF0FF or 0xF100 to 0xF1FF) and the S5 addresses **S5A (7:3)** agree with the I/O base address set in the CP 581 in register **IOBA**.

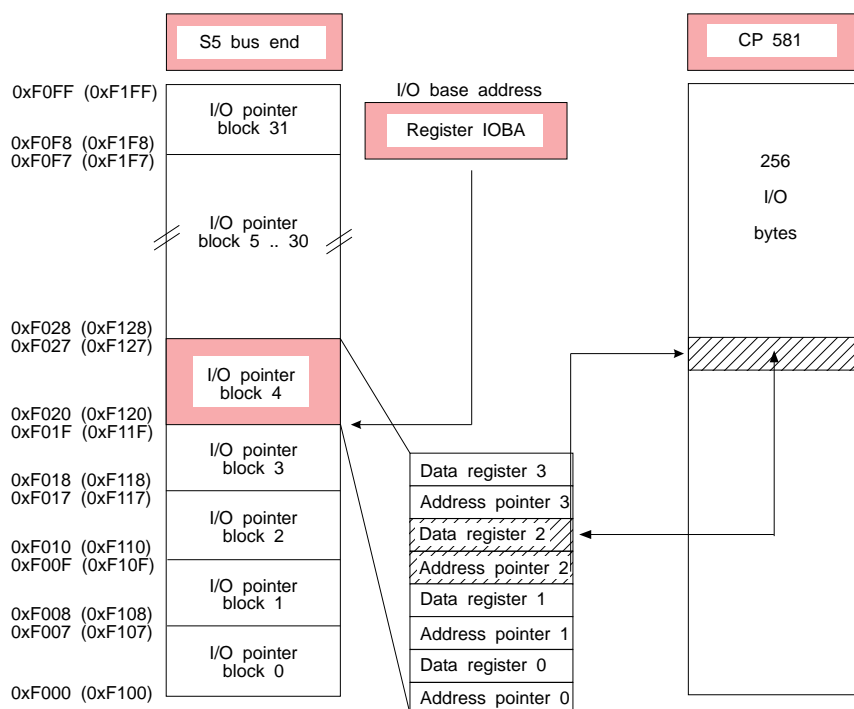

Fig. 3.19 I/O-mapped peripheral access

Technical Data of the CP 581

4

Contents of Chapter 4

4.1	Basic Board	4 - 3
4.1.1	Device-specific Data	4 - 3
4.1.2	Power Supply	4 - 3
4.1.3	Current Consumption	4 - 3
4.1.4	Safety	4 - 4
4.1.5	Electromagnetic Compatibility (EMC)	4 - 4
4.1.6	Climatic Conditions	4 - 4
4.1.7	Mechanical Environmental Conditions	4 - 5
4.1.8	Logic Parameters	4 - 6
4.2	Mass Storage Module	4 - 10
4.2.1	Device-specific Data	4 - 10
4.2.2	Power Supply	4 - 10
4.2.3	Current Consumption	4 - 10
4.2.4	Safety	4 - 10
4.2.5	Electromagnetic Compatibility (EMC)	4 - 11
4.2.6	Climatic Conditions	4 - 11
4.2.7	Mechanical Environmental Conditions	4 - 12

4

4.2.8	Logic Parameters	4 - 13
4.3	AT-slot Module	4 - 14
4.3.1	Device-specific Data	4 - 14
4.3.2	Power Supply	4 - 14
4.3.3	Current Consumption	4 - 14
4.3.4	Maximum Loading of AT-slot Modules by AT Interfaces	4 - 15
4.3.5	Safety	4 - 16
4.3.6	Electromagnetic Compatibility (EMC)	4 - 17
4.3.7	Climatic Conditions	4 - 17
4.3.8	Mechanical Environmental Conditions	4 - 18
4.3.9	Permissible Dimensions of AT Modules	4 - 18
4.4	RTI Module	4 - 19
4.4.1	Device-specific Data	4 - 19
4.4.2	Power Supply	4 - 21
4.4.3	Current Consumption	4 - 21
4.4.4	Safety	4 - 21
4.4.5	Electromagnetic Compatibility (EMC)	4 - 22
4.4.6	Climatic Conditions	4 - 22
4.4.7	Mechanical Environmental Conditions	4 - 22

4 Technical Data of the CP 581

4.1 Basic Board

4.1.1 Device-specific Data

Weight	Approx. 0.5 kg
Module format	Double Eurocard format (160 mm x 233.4 mm)
Front panel width	20 mm, 1 1/3 standard slots
Backplane connector	ES 902, series 2, 48-pin
Front plugs:	
Keyboard/COM 2	Female connector, 26-way (D-subminiature, high-density)
COM 1/COM 3	Female connector, 26-way (D-subminiature, high-density)
RGB	3 x coax midi sockets

4

4.1.2 Power Supply

Supply voltages	+5 V, tolerance $\pm 5\%$ +24 V, tolerance $+25\%/-15\%$
-----------------	---

4.1.3 Current Consumption

Current consumption	CP 581	+5 V: max. 1.8 A +24 V: max. 0.1 A
	CP 581/486	+5 V: max. 1.9 A +24V: max. 0.1 A
Back-up current		Max. 0.05 mA

4.1.4 Safety

Standards	IEC 950 = EN 60 950 = DIN VDE 0805
Degree of protection	IP 00 to IEC 529 (DIN 40 050)

4.1.5 Electromagnetic Compatibility (EMC)

Radio interference suppression Limit class A	To CISPR 11 (VDE 0871)
---	------------------------

Noise immunity

Conducted interference on signal cables	To DIN VDE 0843 Part 4 = IEC 65(CO)39-1985(TC65) To IEC 801-4 (burst): 1 kV
Noise immunity to discharges of static electricity	To IEC 801-2 (ESD): 6 kV
Noise immunity to external fields	To IEC 801-3: 3 V/m

4.1.6 Climatic Conditions

Temperature Operation (with and without forced ventilation)	Tested to DIN IEC 68-2-1/2 +5 °C to +55 °C
Storage/transport	-10 °C to +60 °C

Temperature gradient

Operation	Max. 10 K/h
Storage/transport	Max 20 K/h

Relative humidity

Operation	8 to 80 % at 25 °C, no condensation
Storage/transport	8 to 80 % at 25 °C, no condensation

Altitude (referred to mean sea level)

Operation	-50 m to +2500 m
Storage/transport	Up to 10 000 m

4.1.7 Mechanical Environmental Conditions

Oscillations:	Tested to DIN IEC 68-2-6
Operation	10-58 Hz: amplitude 0.075 mm 58-150 Hz: acceleration 9.81 m/s ² (1 g)
Shock:	Tested to DIN IEC 68-2-27
Operation	Half-sine: 150 m/s ² , 11 ms

4.1.8 Logic Parameters

	CP 581	CP 581/486
Processor	80386SL, 25 MHz	80486SL, 33 MHz
Coprocessor	80387SL, 25 MHz	
System controller/ ISA bus controller	82360SL	82360SL
Main memory	4 MB,	
Flash memory	2 MB (200 ns), unformatted 10 000 delete cycles	
Memory card interface	For SIEMENS memory cards	
Keyboard controller	8742	
COM 1/COM 2	In the 82360SL	
COM 3	16C450	
VGA controller	WD 90C11 Technical data: see Table 4.1	CLGD 5426 Technical data: see Table 4.2
Video RAM	512 KB	512 KB
S5 interface	SIEMENS-ASIC max. 8 KB dual-port RAM 256 interprocessor communication flags I/O area Watchdog	

Table 4.1 VGA modes (WD-BIOS, Paradise V4.14 with WD 90C11 ¹⁾) CP 581

Mode	Text/ graphics	Color/BW	Resolution Columns/lines	Number of colors	Horizontal frequency/ kHz	Vertical frequency/ Hz
0,1,2,3 ²⁾	Text	Color	80 X 25	16	31.32	69.76
4,5,6,D,E	Graphics	Color	320/640 X 200	4/16	31.32	69.76
11,12 ²⁾	Graphics	Color/BW	640 X 480	2/16	31.32	59.66
13	Graphics	Color	320 X 200	256	31.32	69.76
7	Text	BW	80 X 25	4	31.32	69.76
F	Graphics	BW	640 X 350	2	31.32	69.76
47	Text	Color	132 X 28	16	31.27	59.56
54	Text	Color	132 X 43	16	30.88	68.77
55	Text	Color	132 X 25	16	30.88	68.77
56	Text	BW	132 X 43	2	30.88	68.77
57	Text	BW	132 X 25	2	30.88	68.77
58	Graphics	Color	800 X 600	16	35.4	56.63
59	Graphics	BW	800 X 600	2	35.4	56.63
5A	Graphics	Color	1024 X 768	2	35.4	86.66 ³⁾
5B	Graphics	Color	1024 X 768	4	35.4	86.66 ³⁾
5C	Graphics	Color	800 X 600	256	35.4	56.63
5D	Graphics	Color	1024 X 768	16	35.4	86.66 ³⁾
5E	Graphics	Color	640 X 400	256	31.32	69.76
5F	Graphics	Color	640 X 480	256	31.32	59.66
6A	Graphics	Color	800 X 600	16	35.4	56.63
6B	Graphics	BW	800 X 600	2	35.4	56.63

¹⁾ See WD BIOS data book, Paradise V4.14, Western Digital
³⁾ Interlaced

²⁾ Default setting (standard VGA)

Table 4.2 VGA modes (Cirrus Logic BIOS V1.2 with CLGD 5426 ¹⁾) CP 581/486

Mode	Text/ graphics	Color/BW	Resolution Columns/lines	Number of colors	Horizontal frequency/ kHz	Vertical frequency/ Hz
0, 1	Text	Color	360 x 400	16	31.5	70
2, 3	Text	Color	720 x 400	16	31.5	70
4, 5	Graphics	Color	320 x 200	4	31.5	70
6	Graphics	Color	640 x 200	2	31.5	70
7	Text	BW	720 x 400	2	31.5	70
D	Graphics	Color	320 x 200	16	31.5	70
E	Graphics	Color	640 x 200	16	31.5	70
F	Graphics	BW	640 x 350	2	31.5	70
10	Graphics	Color	640 x 350	16	31.5	70
11	Graphics	Color	640 x 480	2	31.5	60
12	Graphics	Color	640 x 480	16	31.5	60
12+	Graphics	Color	640 x 480	16	37.9	72
13	Graphics	Color	320 x 200	256	31.5	70
14	Text	Color	1056 x 400	16	31.5	70
54	Text	Color	1056 x 350	16	31.5	70
55	Text	Color	1056 x 350	16	31.5	70
58, 6A	Graphics	Color	800 x 600	16	35.2	56
58, 6A	Graphics	Color	800 x 600	16	37.8	60
58, 6A	Graphics	Color	800 x 600	16	48.1	72
5C	Graphics	Color	800 x 600	256	35.2	56
5C	Graphics	Color	800 x 600	256	37.9	60
5C	Graphics	Color	800 x 600	256	48.1	72

Mode	Text/ graphics	Color/BW	Resolution Columns/lines	Number of colors	Horizontal frequency/ kHz	Vertical frequency/ Hz
5D	Graphics	Color	1024 x 768	16	35.5	87
Table 4.2 continued:						
5D	Graphics	Color	1024 x 768	16	48.3	60
5D	Graphics	Color	1024 x 768	16	56	70
5D	Graphics	Color	1024 x 768	16	58	72
5F	Graphics	Color	640 x 480	256	31.5	60
5F	Graphics	Color	640 x 480	256	37.9	72

¹⁾ See also BIOS V1.2, Cirrus Logic

4.2 Mass Storage Module

4.2.1 Device-specific Data

Weight	Approx. 0.9 kg
Module format	Double Eurocard format (160 mm x 233.4 mm)
Front panel width	20 mm, 1 1/3 standard slots
Backplane connector	ES 902, series 2, 48-pin
Front plugs LPT	Female connector, 25-way (D-subminiature, IBM-compatible)
COM 4	Female connector, 26-way (D-subminiature, high-density)

4.2.2 Power Supply

Supply voltages	+5 V, tolerance $\pm 5\%$ +24 V, tolerance $+25\%/-15\%$
-----------------	---

4.2.3 Current Consumption

Current consumption	+5 V: typically 0.5 A Max. 1 A during restart (approx. 500 ms) +24 V: max. 0.1 A
Back-up current	Not required

4.2.4 Safety

Standards	IEC 950 = EN 60 950 = DIN VDE 0805
Degree of protection	IP 00 to IEC 529 (DIN 40 050)

4.2.5 Electromagnetic Compatibility (EMC)

Radio interference suppression Limit class	To CISPR 11 (VDE 0871) A
Noise immunity	
Conducted interference on signal cables	To DIN VDE 0843 Part 4 = IEC 65(CO)39-1985(TC65) To IEC 801-4 (burst): 1 kV
Noise immunity to discharges of static electricity (relay discharge)	To IEC 801-2 (ESD): 6 kV
Noise immunity to external fields	To IEC 801-3: 3 V/m

4.2.6 Climatic Conditions

Temperature		Tested to DIN IEC 68-2-1/2
Operation with forced ventilation	+5 °C to +55 °C (only 40 °C with floppy disk)	
Operation without forced ventilation	+5 °C to +40 °C	
Storage/transport	-10 °C to +60 °	
Temperature gradient		
Operation	Max. 10 K/h	
Storage/transport	Max. 20 K/h	
Relative humidity		
Operation	8 to 80 % at 25 °C, no condensation	
Storage/transport	8 to 80 % at 25 °C, no condensation	
Altitude (referred to mean sea level)		
Operation	-50 m to +2500 m	
Storage/transport	Up to 10 000 m	

4.2.7 Mechanical Environmental Conditions

Oscillations:	Tested to DIN IEC 68-2-6
Operation	10-58 Hz: amplitude 0.035 mm 58-500 Hz: acceleration 4.9 m/s ² (0.5 g) (measured on drive)
Transport	5-9 Hz: amplitude 3.5 mm 9-500 Hz: acceleration 10 m/s ² (1 g)
Shock:	Tested to DIN IEC 68-2-27
Operation	Half-sine: 50 m/s ² (5 g), 11 ms (measured on drive)
Transport	Half-sine: 500 m/s ² (50 g), 11 ms



Note

The specified limits are as a result of the hard disk drive. The values must not be exceeded on the drive.

4.2.8 Logic Parameters

Hard disk CP 581

6ES5 581-0LA11

MTBF

Start/stop cycles

Conner CP2064

2.5", 60 MB, 19 ms, IDE interface

100 000 h

> 40 000

Hard disk CP 581/486

6ES5 581-1LA11

MTBF

Start/stop cycles

Conner CP2124

2.5", 120 MB, 17 ms, IDE interface

100 000 h

> 40 000

Floppy disk drive

Type

Floppy controller

MTBF

TEAC FD-05-HF (3.5", 1.44 Mbyte)

Intel 82077A

30 000 h (typical operation)

Interfaces

LPT/COM 4

16C452



4.3 AT-slot Module

4.3.1 Device-specific Data

Weight	Approx. 0.3 kg
Module format	Results in approx. double Eurocard format together with AT module (see also Section 4.3.9)
Front panel width	20 mm, 1 1/3 standard slots
Backplane connector	None
Front connector	None



Note

A maximum of 2 AT-slot modules can be operated simultaneously in **one** CP 581 system.

4.3.2 Power Supply

Supply voltages	+5 V, tolerance $\pm 5\%$
-----------------	---------------------------

4.3.3 Current Consumption

Current consumption without AT module	+5 V: typically 0.3 A
Back-up current	Not required

4.3.4 Maximum Loading of AT-slot Modules by AT Interfaces

Table 4.3 Voltages and maximum loadings for **one** AT-slot module

Voltage	Tolerance range	Max. current
+5 V	4.75 V to 5.25 V	4 A
-5 V	-4.4 V to -5.3 V	70 mA
+12 V	11.7 V to 12.3 V	500 mA
-12 V	-10.9 V to -13.5 V	100 mA

Note



All voltages available on the AT bus of the AT-slot module are generated by the 5-V power supply. This means that all loads also have an effect on the 5-V supply of the AT-slot module.

The 5-V supply for 2 AT-slot modules must not be loaded by more than 6 A.

It should additionally be noted that 20 W must not be exceeded per AT-slot module because of the warming-up resulting from the heat loss. **Without forced ventilation**, this value is reduced to 7.5 W.

4

Calculation of current consumption of AT modules:

Using the following equation you can check whether the power supply will be overloaded. (I' in this equation is the current consumed by a second AT-slot module).

$$I_{(+12V)} * 4 + I_{(+5 V)+ 0.3 A} + [I'_{(+12V)} * 4 + I'_{(+5V)} + 0.3 A]_{(AT-slot 2)} \leq 6 A$$

The loading of the -5 V and -12 V supplies need not be considered. The maximum values listed in Table 4.2 must not be exceeded, however.

Calculation example for an assumed configuration:

Voltage	Current consumption	Factor	Loading of 5-V supply
1st AT module (in AT-slot B.1)			
+12 V	0.3 A	4	1.2 A
+ 5 V	1.0 A	1	1.0 A
Basic load	0.3 A	1	0.3 A
Total current/power loss of 1st AT module			2.5 A/12.5 W
2nd AT module (in AT-slot B.2)			
+12 V	0.05 A	4	0.2 A
+5 V	1.0 A	1	1.0 A
Basic load	0.3 A	1	0.3 A
Total current/heat loss of 2nd AT module			1.5 A/7.5 W

In this example, the total current of the 1st AT module is 2.5 A and that of the 2nd AT module 1.3 A. The loading resulting from the first AT module necessitates forced ventilation.

This configuration is therefore only permissible with fans. The 2nd AT module on its own could also be operated without fans.

The total current in this example is 4 A and thus below the maximum value of 6 A. This configuration is therefore permissible.

4.3.5 Safety

Standards

IEC 950 = EN 60 950 = DIN VDE 0805

Degree of protection

IP 00 to IEC 529 (DIN 40 050)

4.3.6 Electromagnetic Compatibility (EMC)

Radio interference suppression
Limit class A To CISPR 11 = VDE 0871

Noise immunity

Conducted interference
on signal cables To DIN VDE 0843 Part 4 =
IEC 65(CO)39-1985(TC65)
To IEC 801-4 (burst): 1 kV

Noise immunity to discharges
of static electricity To IEC 801-2 (ESD): 6 kV

Noise immunity to external fields To IEC 801-3: 3 V/m

Note



The values depend on the AT module used.

4

4.3.7 Climatic Conditions

Temperature

Operation (with and without forced
ventilation)
Storage/transport

Tested to DIN IEC 68-2-1/2

+5 °C to +55 °C
-10 °C to +60 °C

Temperature gradient

Operation
Storage/transport

Max. 10 K/h
Max. 20 K/h

Relative humidity

Operation
Storage/transport

8 to 80 % at 25 °C, no condensation
8 to 80 % at 25 °C, no condensation

Altitude (above mean sea level)

Operation
Storage/transport

-50 m to +2500 m
Up to 10 000 m

4.3.8 Mechanical Environmental Conditions

Oscillations: Tested to DIN IEC 68-2-6
 Operation 10-58 Hz: amplitude 0.075 mm
 58-150 Hz: acceleration 9.81 m/s^2 (1 g)

Shock: Tested to DIN IEC 68-2-27
 Operation Half-sine: 150 m/s^2 , 11 ms

4.3.9 Permissible Dimensions of AT Modules

The following Fig. indicates the maximum and minimum dimensions in mm which the AT modules for the CP 581 must observe. Correct installation in the CP 581 system is not possible if the dimensions are exceeded or fallen below.

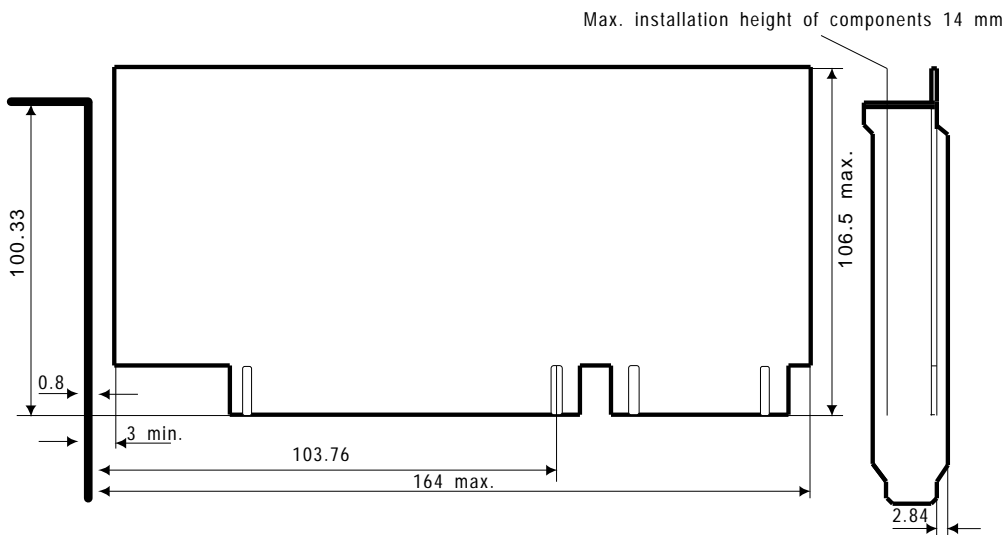

Fig. 4.1 Dimensions of AT modules to be installed in the CP 581 system (in mm)

4.4 RTI Module

4.4.1 Device-specific Data

Weight	Approx. 0.3 kg
Format	See Fig. 4.2
Front plugs: Host	Female connector, 25-way (D-subminiature)
Version -3AA11: Mouse in connection with CP 581	Female connector, 9-way (D-subminiature)
Version -3AA12: Mouse/Light pen in connection with CP 581/486	Female connector, 9-way (D-subminiature)
Keyboard	Round socket, 7-way

4

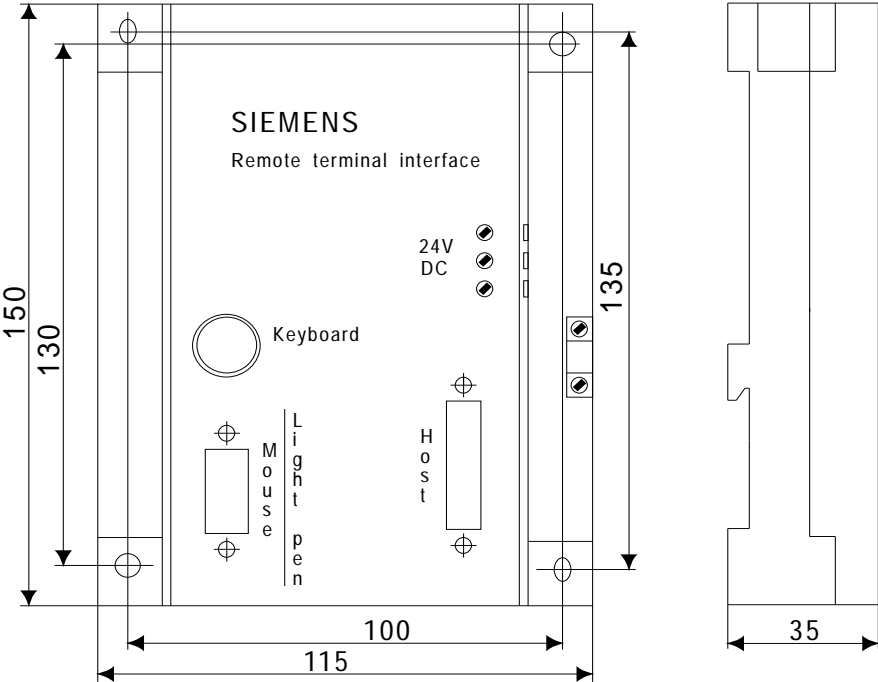

Fig. 4.2 Dimensions of the RTI module (in mm)

4.4.2 Power Supply

Supply voltages

+24 V, tolerance 19 to 32 V, to be supplied acc. to VDE 0160



Caution

Only an extra-low voltage of ≤ 60 V DC safely isolated from the supply voltage may be used for the 24 V DC power supply. The safe isolation can be either corresponding to the requirements in VDE 0100 part 410/HD 384-4-41/IEC 364-4-41 (as a functional extra-low voltage (FELV) with safe isolation) or in VDE 0805/EN 60950/IEC 950 (as a safety extra-low voltage (SELV)) or VDE 0106 part 101.

4.4.3 Current Consumption

Current consumption

+24 V: max. 0.2 A

4

4.4.4 Safety

Standards

IEC 950 = EN 60 950 = DIN VDE 0805

Degree of protection

IP 00 to IEC 529 (DIN 40 050)

4.4.5 Electromagnetic Compatibility (EMC)

Radio interference suppression
Limit class A

To CISPR 11 (VDE 0871)

EMC noise immunity

Conducted interference on
signal cables

To DIN VDE 0843 Part 4 =
IEC 65(CO)39-1985(TC65)
To IEC 801-4 (burst): 1 kV

Noise immunity to discharges of static
electricity (relay discharge)

To IEC 801-2 (ESD): 6 kV

Noise immunity to external fields

To IEC 801-3: 3 V/m

4.4.6 Climatic Conditions

Temperature

Operation

Tested to DIN IEC 68-2-1/2

Storage/transport

+5 °C to +55 °C

-10 °C to +60 °C

Temperature gradient

Operation

Max. 10 K/h

Storage/transport

Max. 20 K/h

Relative humidity

Operation

8 to 80 % at 25 °C, no condensation

Storage/transport

8 to 80 % at 25 °C, no condensation

Altitude (referred to mean sea level)

Operation

-50 m to +2500 m

Storage/transport

Up to 10 000 m

4.4.7 Mechanical Environmental Conditions

Oscillations:

Operation

Tested to DIN IEC 68-2-6

10-58 Hz: amplitude 0.075 mm

58-150 Hz: acceleration 9.81 m/s² (1 g)

Shock:

Operation

Tested to DIN IEC 68-2-27

Half-sine: 150 m/s² (5 g), 11 ms

Appendix

5

List of Abbreviations

Index

List of Tables and Figures

5

List of Abbreviations

BIOS	Basic input output system
CP	Communications processor
CPDHB	CPDHB driver
CPU	S5 CPU
DHB	Data handling block
DMA	Direct memory access
DPR	Dual-port RAM
EMC	Electromagnetic compatibility
FD	Floppy disk, diskette
FMS	Flash memory system
HD	Hard disk
KBD	Keyboard
PG	Programmer
PLC	Programmable (logic) controller
SD	Silicon disk
TCB	Transfer control block
TSR program	Terminate and stay resident program

Index

A			
Adapter casing		2-39	
B			
Backplane connector		3-28	
Basic board		3-6	
C			
Central controllers		2-39 - 2-41	
Coaxial cable		2-38	
Command interpreter		2-58	
applications		1-7	
Configurations		2-5	
Controls		3-11	
Conversion		3-99	
CP 581			
definition		1-3	
operating system		1-4	
possible applications		1-5	
CPDHB driver		2-58	
CPLINK		2-67	
data transfer		2-68	
installation options		2-71	
structure		2-68	
E			
EMC,			
electromagnetic compatibility		2-47	
Equipotential bonding		2-47	
Expansion unit		2-42	
F			
Floppy disk drive		3-44	
Floppy disks		3-44	
Free programming			
applications		1-7	
Front panel		2-45	
G			
Grounding rail		2-38	
H			
Hard disk drive		3-44	
Hardware			
design		2-36	
I			
Installation guidelines		2-36	
Interface			
COM 1		3-20	
COM 2		3-22	
COM 3		3-21	
parallel interface for printer		2-50	
TTY		2-52	
V.24		2-52	
VIDEO		3-27	
K			
Key RESET		3-11	
Keyboard		3-18	

M		S	
Mass storage functions	2-58	SETUP	
applications	1-6	basic setting	3-80
Monitor	2-47, 3-19	execution	3-78
monitor cable	2-47, 2-52	Slots	2-40 - 2-41
monitor housing	2-47	Software installation	2-55
office monitors	2-49	Subrack	2-43
Mouse	2-51, 3-18	Switch RUN/STOP	3-11
N		T	
Normal restart	2-58	Transport position	3-44
		Triax cable	2-47
O		V	
Operation displays	3-11	VGA modes	4-7
		Virtual S5 drive	
		applications	1-7
P			
Peripheral devices	2-45, 2-52		
PLC rack	2-43		
Power supply	2-39		
Process data acquisition			
applications	1-6		
R			
Repair	3-99		
Restart			
with manual SETUP	3-77		
without manual SETUP	3-77		

List of Tables and Figures

List of Tables

Table 2.1	Maximum cable lengths for operation devices and peripheral devices	2 - 52
Table 2.2	CPLINK: settings for the COM interface	2 - 72
Table 2.3	Illegal DOS functions with remote handling	2 - 79
Table 3.1	Operation and fault displays on the LEDs	3 - 12
Table 3.2	Recommended printers	3 - 17
Table 3.3	Pin assignments of plug X6	3 - 20
Table 3.4	Pin assignments of plug X7 for keyboard and COM 2	3 - 22
Table 3.5	Pin assignments of plug X15 for a memory card	3 - 23
Table 3.6	Pin assignments of backplane connector X1 (top of basic board)	3 - 28
Table 3.7	Pin assignments of backplane connector X2 (bottom of basic board)	3 - 29
Table 3.8	Pin assignments of connectors X4 and X8 for expanded memory (CP 581)	3 - 31
Table 3.9	Pin assignments of connectors X4 and X8 for expanded memory (CP 581/486)	3 - 33
Table 3.10	Pin assignments of ISA bus connector X10	3 - 35
Table 3.11	Assignment of I/O address area	3 - 38
Table 3.12	Summary of hardware interrupts	3 - 40
Table 3.13	Default setting of switch S101	3 - 45
Table 3.14	Default setting of plug-in jumper X6	3 - 45
Table 3.15	Default setting of plug-in jumper X7	3 - 46
Table 3.16	Default setting of plug-in jumper X32	3 - 46
Table 3.17	Signal assignments of the parallel interface LPT (Centronics)	3 - 47
Table 3.18	Signal assignments of the serial interface COM 4	3 - 49
Table 3.19	Pin assignments of backplane connector X1 (top of mass storage module)	3 - 51
Table 3.20	Pin assignments of backplane connector X2 (bottom of mass storage module)	3 - 52

Table 3.21	ATSLOT jumper setting/switch S1 (see Fig. 3.8)	3 - 55
Table 3.22	Pin assignments of external interface	3 - 57
Table 3.23	RTI interface and pin assignments	3 - 65
Table 3.24	Signal assignments of connection cable CP 581 ↔ RTI	3 - 67
Table 3.25	Signal assignments of connection cables CP 581 ↔ printer, V.24	3 - 68
Table 3.26	Signal assignments of Y adapter keyboard/COM 2	3 - 69
Table 3.27	Signal assignments of Y adapter COM 1/COM 3	3 - 70
Table 3.28	Parameters and default settings of the BIOS status page	3 - 81
Table 3.29	Parameters and default settings with BIOS S5 page: control	3 - 86
Table 3.30	Parameters and default settings with BIOS S5 page: page frame	3 - 87
Table 3.31	Parameters and default settings with BIOS S5 page: I/O pointer	3 - 87
Table 3.32	Parameters and default settings with BIOS S5 page: communication flags	3 - 88
Table 3.33	Parameters and default settings with BIOS options page: memory controller	3 - 90
Table 3.34	Parameters and default settings with BIOS options page: cache controller	3 - 90
Table 3.35	Parameters and default settings with BIOS options page: speed control	3 - 92
Table 3.36	Parameters and default settings with BIOS options page: peripherals configuration	3 - 93
Table 3.37	Parameters and default settings with BIOS options page: memory controller	3 - 96
Table 3.38	Parameters and default settings with BIOS options page: cache controller	3 - 96
Table 3.39	Parameters and default settings with BIOS options page: speed control	3 - 97
Table 3.40	Parameters and default settings with BIOS options page: peripherals configuration	3 - 97
Table 4.1	VGA modes (WD-BIOS, Paradise V4.14 with WD 90C11) CP 581	4 - 7
Table 4.2	VGA modes (Cirrus Logic BIOS V1.2 with CLGD 5426) CP 581/486	4 - 8
Table 4.3	Voltages and maximum loadings for one AT-slot module	4 - 15

List of Figures

Fig. 1.1	The CP 581 communications processor in the automation pyramid	1 - 9
Fig. 2.1	Possible connections with keyboard, monitor, printer and mouse (configuration 1a)	2 - 10
Fig. 2.2	Possible connections with keyboard, monitor, printer and light pen (configuration 1b)	2 - 11
Fig. 2.3	Possible connections with keyboard, monitor, printer and mouse (configuration 2a)	2 - 12
Fig. 2.4	Possible connections with keyboard, monitor, printer and light pen (configuration 2a)	2 - 13
Fig. 2.5	Cross-section of basic board for installation of memory extension	2 - 17
Fig. 2.6	Connection of modules using tongue and groove	2 - 19
Fig. 2.7	Assembly accessories for the mass storage module	2 - 21
Fig. 2.8	Assembly of the mass storage module onto the basic board	2 - 23
Fig. 2.9	Assembly accessories for the AT-slot modules	2 - 25
Fig. 2.10	Assembly of one AT-slot module onto the basic board	2 - 27
Fig. 2.11	Assembly of two AT-slot modules onto the basic board	2 - 29
Fig. 2.12	Assembly of one AT-slot module onto the mass storage module	2 - 31
Fig. 2.13	Assembly of two AT-slot modules onto the mass storage module	2 - 33
Fig. 2.14	Assembly of an AT board onto an AT-slot module	2 - 35
Fig. 2.15	Cabinet design	2 - 37
Fig. 2.16	Cable connection to grounding rails	2 - 48
Fig. 2.17	SETUP menu	2 - 61
Fig. 2.18	Data transfer	2 - 68
Fig. 2.19	CPLINK structure	2 - 69
Fig. 2.20	Establishing/clearing the connection in the course of booting	2 - 77
Fig. 2.21	Assignment of connecting cable for CPLINK application	2 - 78
Fig. 3.1	Design of CP 581 basic board	3 - 7
Fig. 3.2	Design of CP 581/486 basic board	3 - 9
Fig. 3.3	Positions of controls, displays and interfaces on the basic board	3 - 10
Fig. 3.4	Wiring diagram of RGB/VGA adapter	3 - 28
Fig. 3.5	Assignment of memory address area	3 - 37
Fig. 3.6	Design of CP 581 mass storage module	3 - 42
Fig. 3.7	Front panel of mass storage module	3 - 43
Fig. 3.8	Design of CP 581 AT-slot module (with AT extension card)	3 - 54

Fig. 3.9	98-pin standard direct plug	3 - 56
Fig. 3.10	CP 581 configuration with remote terminal interface with mouse	3 - 61
Fig. 3.11	CP 581/486 configuration with remote terminal interface with light pen	3 - 63
Fig. 3.12	SETUP form (BIOS status page) with default settings	3 - 80
Fig. 3.13	BIOS S5 page with default settings	3 - 85
Fig. 3.14	BIOS options page with default settings	3 - 89
Fig. 3.15	BIOS options page with default settings	3 - 95
Fig. 3.16	Memory assignment of S5 interface	3 - 100
Fig. 3.17	Interrupt triggering with S5 interface	3 - 101
Fig. 3.18	Interrupt register with S5 interface	3 - 102
Fig. 3.19	I/O-mapped peripheral access	3 - 115
Fig. 4.1	Dimensions of AT modules to be installed in the CP 581 system (in mm)	4 - 18
Fig. 4.2	Dimensions of the RTI module (in mm)	4 - 20

Ordering Information

6

Contents of Chapter 6

CP 581 components	6 - 3
CP-581/486 components	6 - 3
Extensions for the basic board CP 581	6 - 4
Extensions for the basic board CP 581/486	6 - 4
Remote terminal interface (RTI)	6 - 4
Light pen	6 - 4
Connection cables and adapters	6 - 5
Memory cards	6 - 5
CP 581 software	6 - 6



SIMATIC S5 STEP 5 programming package and PG connection cable . . .	6 - 7
Manuals	6 - 7
Printers	6 - 8
Interface modules and character set modules	6 - 8
Standard cable connectors	6 - 9
PG keyboard and mouse	6 - 9
Monitors	6 - 10
Monitor cable	6 - 10
Coax midi socket	6 - 10
Length codes for monitor cable	6 - 11
S5-115U	6 - 12

6 Ordering Information

In this chapter

you can find the order nos. of the products mentioned or described in this manual.

CP 581 components

Designation	Order No.
CP 581 basic board, 4 Mbytes, without onboard silicon disk	6ES5 581-0EA11
CP 581 basic module, 4 Mbytes, with onboard silicon disk	6ES5 581-1EA11
CP 581 mass storage module	6ES5 581-0LA11
CP 581 AT-slot module	6ES5 581-0RA11

CP-581/486 components

Designation	Order No.
CP 581/486 basic board, 4 Mbytes, without onboard silicon disk	6ES5 581-0EB11
CP 581/486 basic board, 4 Mbytes, with onboard silicon disk	6ES5 581-1EB11
CP 581/486 mass storage module, 120 Mbytes	6ES5 581-1LA11
CP 581/486 AT-slot module	6ES5 581-0RA12



Extensions for the basic board CP 581

Designation	Order No.
Memory extension to 8 Mbytes	6ES5 581-0HA11
Coprocessor 80387SL	6ES5 581-0KA11

Extensions for the basic board CP 581/486

Designation	Order No.
Memory extension to 20 Mbytes	6ES5 581-0HB11

Remote terminal interface (RTI)

Designation	Order No.
RTI module	6ES5 751-3AA11
RTI module (additionally for light pen)	6ES5 751-3AA12

Light pen

Designation	Order No.
CP 581 light pen	6ES5 982-4AA11

Connection cables and adapters

Designation	Order No.
Connection cable for RTI (-3AA11)	6ES5 714-1xxx1
Connection cable for RTI (-3AA12)	6ES5 714-3xxx1
Y adapter (COM 1/COM 3)	6ES5 714-2AS01
Y adapter (keyboard/COM 2)	6ES5 714-2AT01
RGB/VGA adapter	6ES5 714-2AV01

Memory cards

 Note
The flash EPROMs must be deleted when formatting and overwriting a flash memory card. The number of delete operations is currently limited to approx. 10 000 as a result of the physical characteristics of the flash EPROMs.

Designation	Order No.
Flash EPROM, 1 Mbyte	6ES5 374-2FK21
Flash EPROM, 2 Mbytes	6ES5 374-2FL21
Flash EPROM, 4 Mbytes	6ES5 374-2FM21
Flash EPROM, 8 Mbytes ¹⁾	6ES5 374-2FP21
Flash EPROM, 16 Mbytes ¹⁾	6ES5 374-2FS21

Designation	Order No.
"Memory cards" continued	
RAM, 512 Kbytes	6ES5 374-2AJ21
RAM, 1 Mbyte	6ES5 374-2AK21
RAM, 2 Mbytes	6ES5 374-2AL21

¹⁾ can be used from BIOS V2.3 (386) or V 1.1 (486) upwards

CP 581 software

Designation	Order No.
CP 581 system software (international)	6ES5 835-8MD01
MS-DOS 5.0, German	6ES5 895-0BS11
MS-DOS 5.0, English	6ES5 895-0BS21
MS-DOS 5.0, French	6ES5 895-0BS31

SIMATIC S5 STEP 5 programming package and PG connection cable

Designation		Order No.
STEP 5 programming package for PC, floppy disks 3.5" and 5.25" (contains the full range of STEP 5 functions also contained in the STEP 5 programming package for PGs)	German	6ES5 896-0SA11
	English	6ES5 896-0SA21
	French	6ES5 896-0SA31
PG connection cable		6ES5 734-2xxx0

Manuals

Designation	Order No.
CP 581 manual, German	6ES5 998-2AT11
CP 581 manual, English	6ES5 998-2AT21
CP 581 manual, French	6ES5 998-2AT31

Printers

Designation	Order No.
SICOMP DR 210-N, 9-needle printer, A4, 8 1/4" x 11 3/4"	6AP1800-0AA00
SICOMP DR 211-N, 9-needle printer, A3, 16 1/2" x 11 3/4"	6AP1800-0BA00
SICOMP DR 230-N, 24-needle printer, A4, 8 1/4" x 11 3/4"	6AP1800-0CA00
SICOMP DR 231-N, 24-needle printer, A3, 16 1/2" x 11 3/4"	6AP1800-0DA00

Interface modules and character set modules

Designation	Order No. for DR 210/DR 211	Order No. for DR 230/DR 231
Centronics with standard character set	6AP1800-0AB00	6AP1800-0AB10
V.24 with standard character set	6AP1800-0AB20	6AP1800-0AB60
TTY with standard character set	6AP1800-0AC60	6AP1800-0AB30
V.24 with ECMA character set	In preparation	6AP1800-0AD00
TTY with EMCA character set	In preparation	6AP1800-0AD10

Standard cable connectors

Designation	Order No.
Centronics, 2 m long	6AP1901-0AL00
V.24 cable, 25-pin plug onto 25-pin plug, 5 m long	6AP1901-0AS00

PG keyboard and mouse

Designation	Order No.
Keyboard for CP 581 (keyboard for PG)	6EA9501-3CA00-0AX0
M32 mouse	6AC1013-4MA011

Monitors

Designation	Order No.
Industrial monitors: - PM 36-C1, 36 cm (see Catalog ST 80) Desk-top version Chassis Rack - PM 36-C2, 36 cm (see Catalog ST 80) Desk-top version Chassis	6AV8011-1FE12-1AA0 6AV8021-1FE12-1AA0 6AV8031-1FE12-1AA0 6AV8011-1FE22-1CA0 6AV8021-1FE22-1CA0
Office monitors: - PM 51-C2/C3, 51 cm (see Catalog ST 80) - MP 40 monitor panel, MP 40/C36-B	See Catalog See Catalog

Monitor cable

Designation	Order No.
Double-screened coaxial cable (triax cable) Standard length 3.2 m with sockets (Order no. applies to one length of cable)	6ES5 736-2xxx0

Coax midi socket

Designation	Order No.
Coax midi socket	W79 072-X104

Length codes for monitor cable

Length of cable connector	Order No. extension for cable connector
1.0 m 1.6 m 2.0 m	6ES5 736-2xxx0 ↑↑↑ BB0 BB6 BC0
2.5 m 3.0 m 3.2 m	C5 BD0 BD2
5.0 m 8.0 m 10.0 m	BF0 BJ0 CB0
12.0 m 16.0 m 20.0 m	CB2 CB6 CC0
25.0 m 32.0 m 40.0 m	CC5 CD2 CE0
50.0 m	CF0

S5-115U

Designation	Order No.
Adapter casing for 2 slots	6ES5 491-0LB12
Adapter casing for 4 slots	6ES5 491-0LD11



Note

You can obtain more information from the Catalogs ST 52.1, ST 52.3, ST 54.1 and ST 80 and in the manuals for the respective programmable controllers (see Reference Literature in Volume 2/2).

Guidelines for Handling Electrostatically Sensitive Devices (ESD)

1 What is ESD?

VLSI chips (MOS technology) are used in practically all SIMATIC S5 and TELEPERM M modules. These VLSI components are, by their nature, very sensitive to overvoltage and thus to electrostatic discharge:

They are therefore defined as
"Electrostatically Sensitive Devices".

"ESD" is the abbreviation used internationally.

The following warning label on the cabinets, subracks and packing indicates that electrostatically sensitive components have been used and that the modules concerned are susceptible to touch:

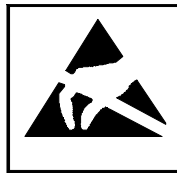

ESDs can be destroyed by voltage and energy levels which are far below the level perceptible to human beings. Such voltages already occur when a component or a module is touched by a person who has not been electrostatically discharged. Components which have been subjected to such overvoltages cannot, in most cases, be immediately detected as faulty; the fault occurs only after a long period in operation.

An electrostatic discharge

- of 3500 V can be felt
- of 4500 V can be heard
- must take place at a minimum of 5000 V to be seen.

But just a fraction of this voltage can already damage or destroy an electronic component.

The typical data of a component can suffer due to damage, overstressing or weakening caused by electrostatic discharge; this can result in temporary fault behavior, e.g. in the case of

- temperature variations,
- mechanical shocks,
- vibrations,
- change of load.

Only the consequent use of protective equipment and careful observance of the precautions for handling such components can effectively prevent functional disturbances and failures of ESD modules.

2 When is a Static Charge Formed?

One can never be sure that the human body or the material and tools which one is using are not electrostatically charged.

Small charges up to 100 V are very common; these can, however, very quickly rise up to 35 000 V!

Examples of static charge:

– Walking on a carpet	up to	35 000 V
– Walking on a PVC flooring	up to	12 000 V
– Sitting on a cushioned chair	up to	18 000 V
– Plastic desoldering unit	up to	8 000 V
– Books etc. with a plastic binding	up to	8 000 V
– Plastic bags	up to	5 000 V
– Plastic coffee cup	up to	5 000 V

3 Important Protective Measures against Static Charge

- Most plastic materials are highly susceptible to static charge and must therefore be kept as far away as possible from ESDs!
- Personnel who handle ESDs, the work table and the packing must all be carefully grounded!

4 Handling of ESD Modules

- One basic rule to be observed is that electronic modules should be touched by hand only if this is necessary for any work to be done on them. Do not touch the component pins or the conductors.
- Touch components only if
 - the person is grounded at all times by means of a wrist strap
 - or
 - the person is wearing special anti-static shoes or shoes with a grounding strip.
- Before touching an electronic module, the person concerned must ensure that (s)he is not carrying any static charge. The simplest way is to touch a conductive, grounded item of equipment (e.g. a blank metallic cabinet part, water pipe, etc.) before touching the module.
- Modules should not be brought into contact with insulating materials or materials which take up a static charge, e.g. plastic foil, insulating table tops, synthetic clothing, etc.
- Modules should only be placed on conductive surfaces (table with anti-static table top, conductive foam material, anti-static plastic bag, anti-static transport container.)
- Modules should not be placed in the vicinity of visual display units, monitors or TV sets (minimum distance from screen > 10 cm).

The diagram on the next page shows the required protective measures against electrostatic discharge.

5 Measurements and Modification to ESD Modules

- Measurements on modules may only be carried out under the following conditions:
 - the measuring equipment is grounded (e.g. via the PE conductor of the power supply system) or
 - when electrically isolated measuring equipment is used, the probe must be discharged (e.g. by touching the metallic casing of the equipment) before beginning measurements.
- Only grounded soldering irons may be used.

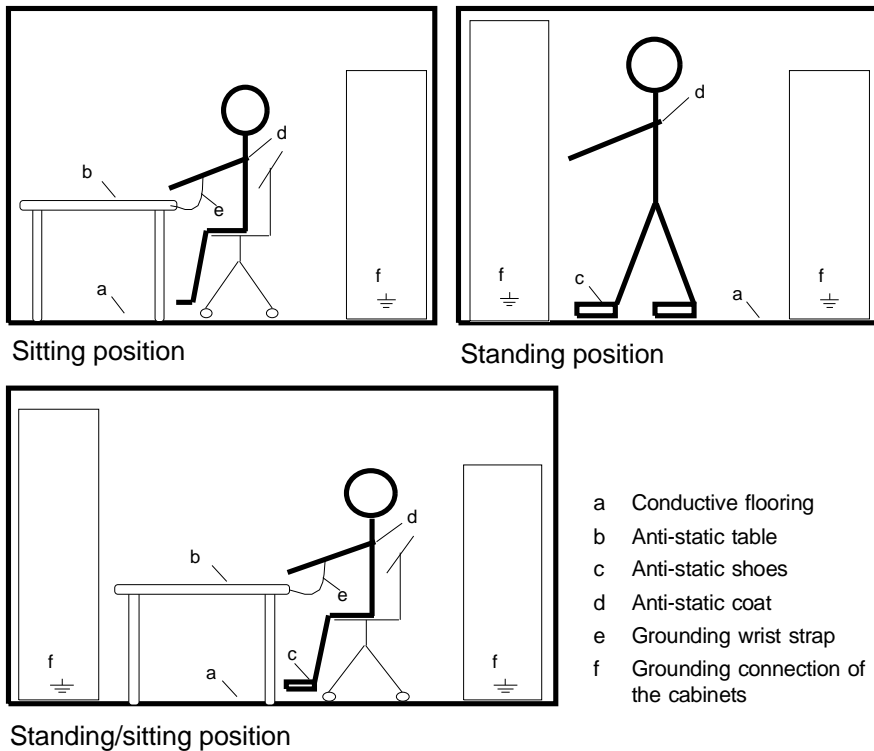

6 Shipping of ESD Modules

Anti-static packing material must always be used for modules and components, e.g. metalized plastic boxes, metal boxes, etc. for storing and dispatch of modules and components.

If the container itself is not conductive, the modules must be wrapped in a conductive material such as conductive foam, anti-static plastic bag, aluminium foil or paper. Normal plastic bags or foils should not be used under any circumstances.

For modules with built-in batteries ensure that the conductive packing does not touch or short-circuit the battery connections; if necessary cover the connections with insulating tape or material.

SIEMENS

SIMATIC S5

Documentation Supplement

C79000-Q8576-C413-02

April 1996

CP 581 Manual, Volume 1/2

6ES5 998-2AT21, Rel. 03

This supplement contains additional information on the CP 581 manual, Volume 1/2, Order No. 6ES5 998-2AT21, release 03.

It is a separate component and the information in it should be considered more up-to-date if uncertainties arise.

© Siemens AG 1996
Subject to alteration

Siemens Aktiengesellschaft



Progress
in Automation.
Siemens

We have checked the contents of this document for agreement with the hardware and software described. Since deviations cannot be precluded entirely, we cannot guarantee full agreement. However, the data in this document are reviewed regularly and any necessary corrections included in subsequent editions. Suggestions for improvement are welcomed.

Technical data subject to change.

The reproduction, transmission or use of this document or its contents is not permitted without express written authority. Offenders will be liable for damages. All rights, including rights created by patent grant or registration of a utility model or design, are reserved.

© Copyright Siemens AG 1996 All Rights Reserved

Siemens Aktiengesellschaft

C79000-Q8576-C413-02
EWK Elektronikwerk Karlsruhe
Printed in the Federal Republic of Germany

Contents

Part 1: Where Does this Supplement Apply?..... 3

Part 2: Additions to the Manual..... 4

 CP 581 Mass storage module..... 4

 Switch and jumper settings..... 4

 Description of plug-in jumpers..... 6

 Jumper assignments on the RTI module..... 9

 Basic description of the TTY interface COM 1..... 11

 CP 581/486 memory assignments..... 13

 BIOS options page with CP 581/486 with system BIOS V1.3 and later..... 14

 Technical data of the CP 581 boards..... 15

 Climatic conditions..... 15

 Logic parameters for VGA:..... 15

 Ordering information..... 18

Part 3: Important Information on CP 581-DX4..... 19

 Hardware description..... 20

 Layout of the module..... 20

 Description of the switch settings..... 23

 CP 581-DX4 memory assignments..... 26

 Logic parameters for VGA..... 27

 BIOS Setup for CP 581-DX4..... 27

 Switching on the PLC/cold restart..... 27

 Warm restart..... 28

 Changing the set BIOS parameters..... 28

 Setup pages:..... 30

 Saving the changed Setup parameters..... 35

 CPLINK..... 36

 Note on formatting memory cards (RAM)..... 39

 System software..... 39

 Changes..... 39

Technical data of the CP 581-DX4	40
Basic board	40
Safety	41
Electromagnetic compatibility (EMC)	41
Climatic conditions	41
Mechanical environmental conditions	42
Logic parameters of CP 581-DX4	42
CP 581-DX4 ordering information	43
Part 4: Replacement Pages for Volume 1/2	45

Part 1: Where Does this Supplement Apply?

This supplement applies to the following boards:

Board	Order No.
RTI module	6ES5 751-3AA12
CP 581 basic board	6ES5 581-0EA11 (without onboard silicon disk) 6ES5 581-1EA11 (with onboard silicon disk)
CP 581 basic board (512 Kbyte VGA memory)	6ES5 581-0EB11 (without onboard silicon disk) 6ES5 581-1EB11 (with onboard silicon disk)
CP 581 basic board (1 Mbyte VGA memory)	6ES5 581-0EB12 (without onboard silicon disk) 6ES5 581-1EB12 (with onboard silicon disk)
CP 581 basic board (1 Mbyte VGA memory, operation without fan)	6ES5 581-0EC12 (without onboard silicon disk) 6ES5 581-1EC12 (with onboard silicon disk)
CP 581-DX4	6ES5 581-0ED12/0ED13

Part 2: Additions to the Manual

CP 581 Mass storage module

Note



The CP 581 mass storage module is equipped with a disk drive which is sensitive to shock and vibration. Please remember this when handling the system.

Only transport this module in its original packing material!

If you do not return the module in its original packing or in an equivalent high-quality packaging, your right to claim under guarantee may be invalid.

Switch and jumper settings

The following figure shows the design of CP 581/486 basic board for the following versions:

6ES5 581-0EB12
6ES5 581-1EB12
6ES5 581-0EC12
6ES5 581-1EC12

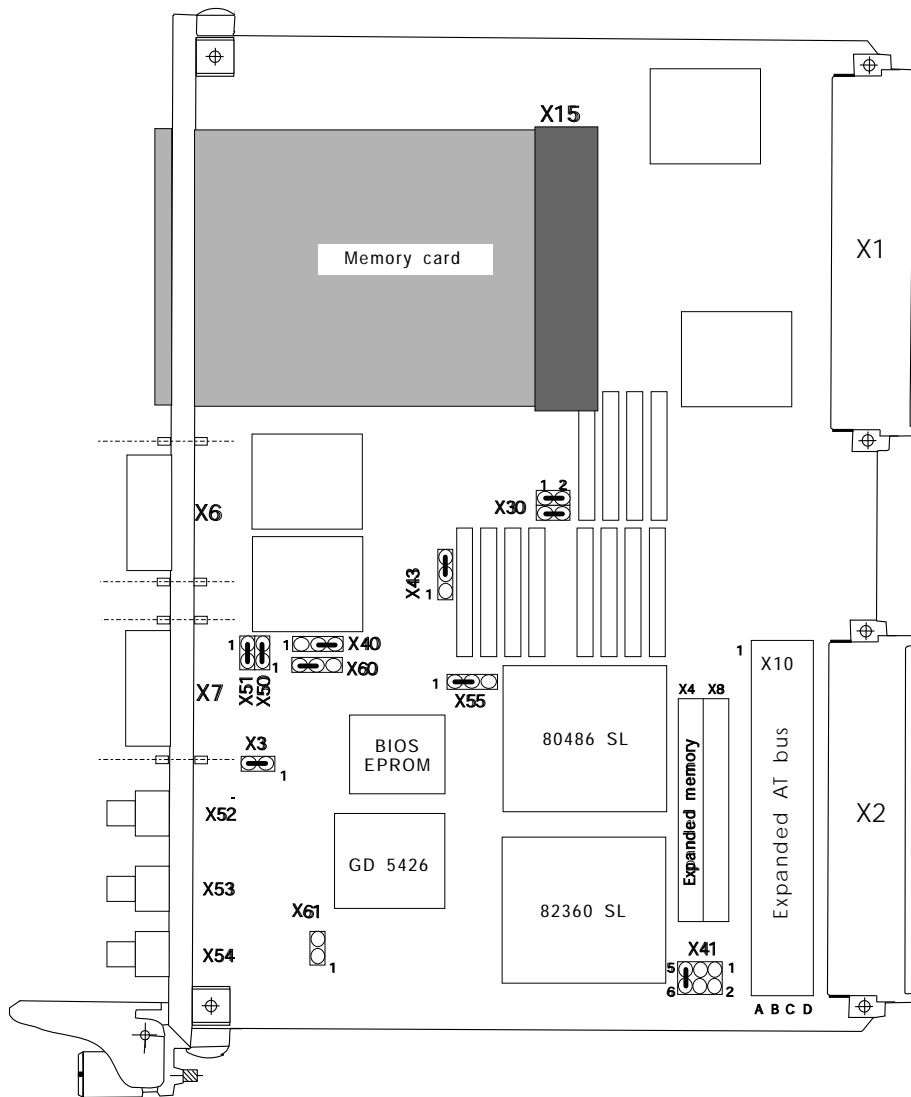

Fig. 1 Design of CP 581/486 basic board

Description of plug-in jumpers

- Jumper X3

PINx - PINy	Effect
1 – 2	PG 750 keyboard (default setting)
No jumper	Standard keyboard

- Jumper X41

PINx - PINy	Effect
1 – 2	COM 3 interrupt at IRQ 5
3 – 5	COM 3 interrupt at IRQ 10
2 – 4	COM 3 interrupt at IRQ 4
5 – 6	COM 3 interrupt at IRQ 11 (default setting)
No jumper	COM 3 interrupt not connected

- Jumper X50

PINx - PINy	Effect
1 – 2	COM 1: "TTY receive" active (default setting)
No jumper	COM 1: "TTY receive" passive

- Jumper X51

PINx - PINy	Effect
1 – 2	COM 1: "TTY transmit" active (default setting)
No jumper	COM 1: "TTY transmit" passive

- Jumper X40

PINx - PINy	Effect
1 – 2	COM 2 RS 485
2 – 3	COM 2 RS 422 (default setting) ¹⁾
No jumper	Illegal

¹⁾ Jumper must be inserted for use with a mouse via RTI.

- Jumper X55

PINx - PINy	Effect
1 – 2	Illegal
2 – 3	Watchdog triggers reset (default setting)
No jumper	Watchdog has no effect

- Jumper X43

PINx - PINy	Effect
1 – 2	COM 3 RS 485
2 – 3	COM 3 RS 422 (default setting)
No jumper	Illegal

- Jumper X30

PINx - PINy	Effect
1 – 2	No effect
3 – 4 inserted	Onboard VGA activated (default setting)
3 – 4 open	Onboard VGA deactivated

- Jumper X60

PINx - PINy	Effect
1 – 2	RI (signal "Ring indicator") on COM 2 (e.g. for modem mode, default)
2 – 3	Light pen operation at COM 2

- Jumper X61

PINx - PINy	Effect
1 – 2	VGA interrupt at IRQ 9
Open	IRQ-9 – VGA interrupt not connected (default setting)

Jumper assignments on the RTI module

The following figure shows the internal design of the RTI module, including the positions of the jumpers and plugs (information supplementary to Section 3.4.6).

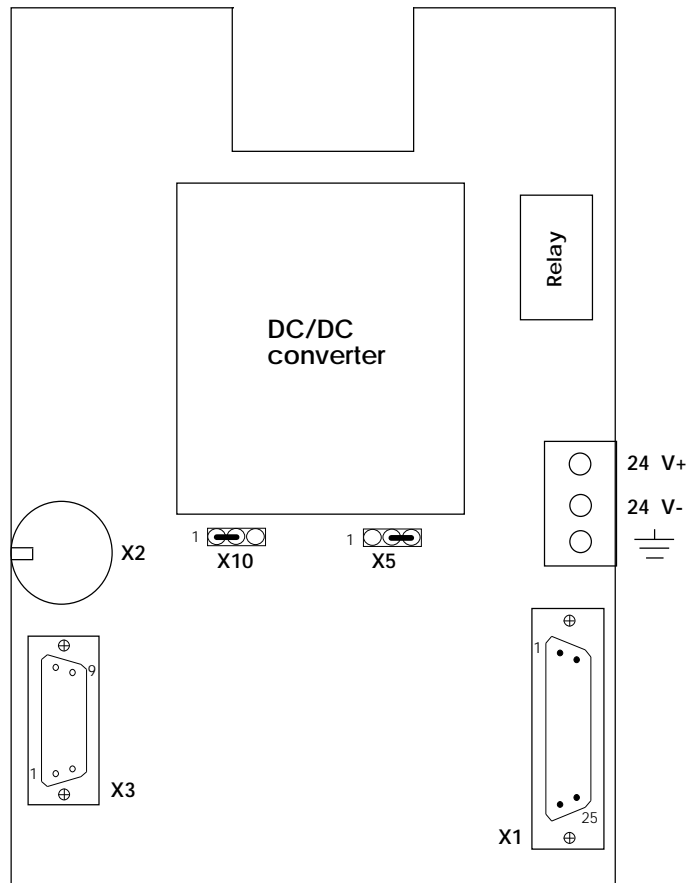

Fig. 2 Inner design of RTI module

- Jumper X10

PINx - PINy	Effect
1 – 2	IBM-compatible keyboard (default setting)
2 – 3	PG 750 keyboard

- Jumper X5

PINx - PINy	Effect
1 – 2	Light pen operation
2 – 3	Mouse operation (default setting)

Basic description of the TTY interface COM 1

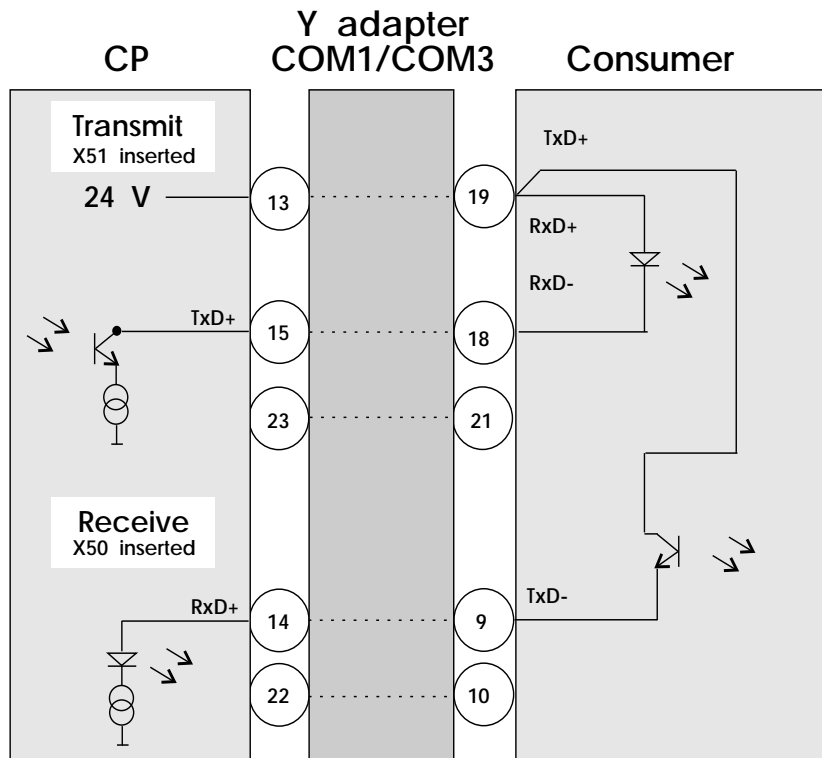

Fig. 3 TTY connection: CP 581 active

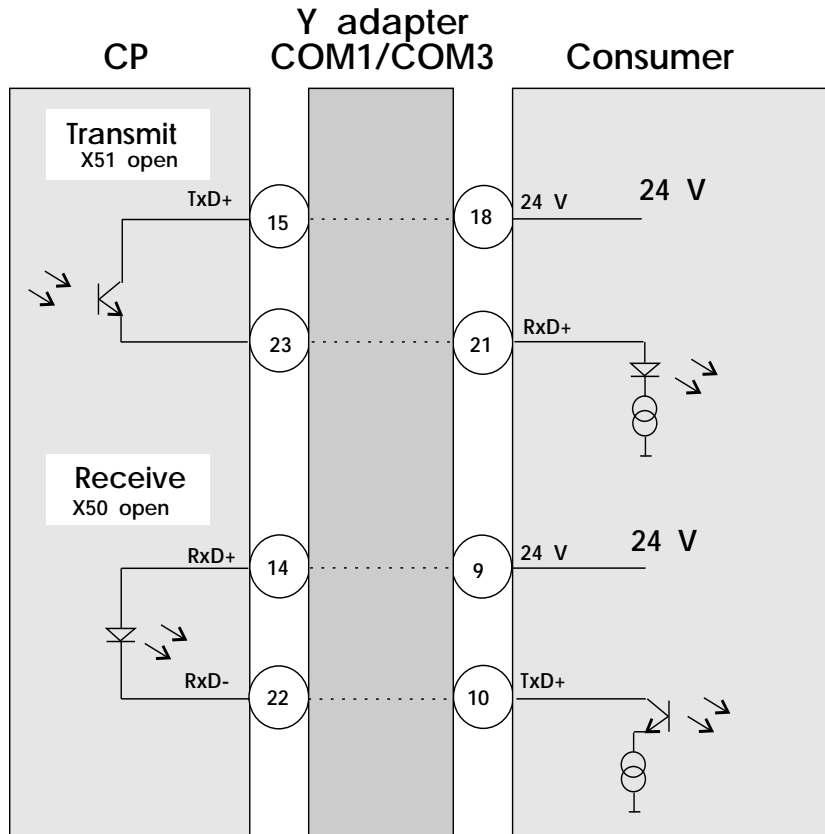
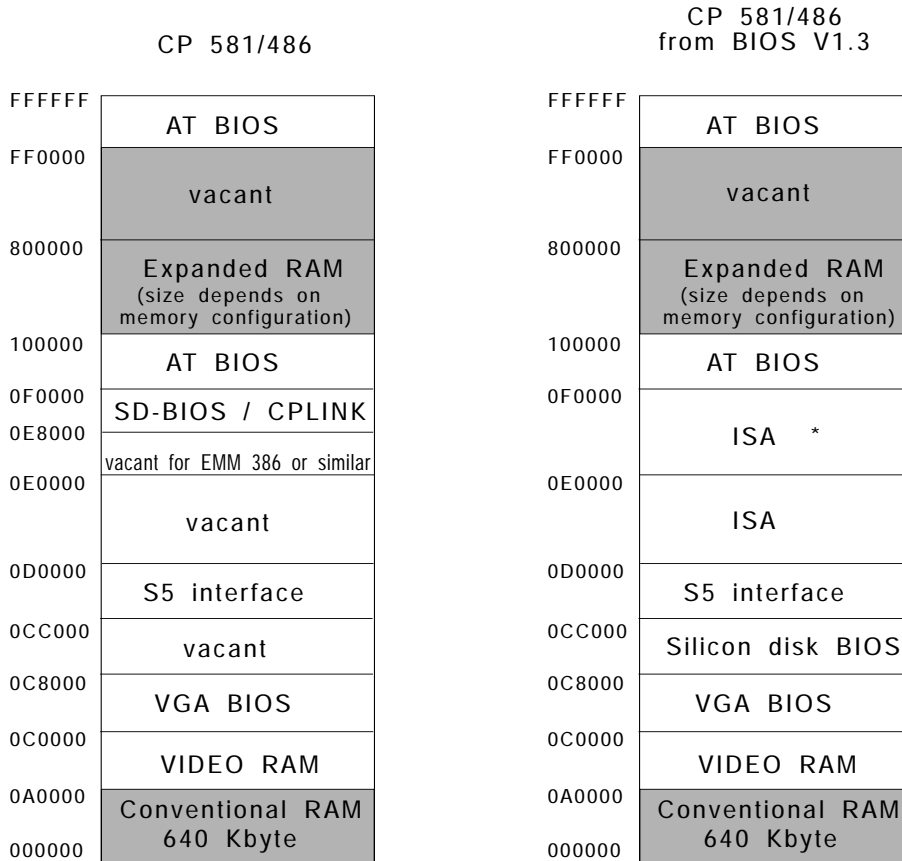

Fig. 4 TTY connection: CP 581 passive

CP 581/486 memory assignments

The address areas are divided into
 - the memory address area and
 - the I/O address area.



* VGA in the shadow RAM

Fig. 5 Assignment of memory address area with CP 581/486

BIOS options page with CP 581/486 with system BIOS V1.3 and later

Memory controller

Input area	Possible inputs	Description
Shadow	Switching-on of shadow	RAM for system and video ROMs
	Disabled	No shadow -RAM
	System	Shadow for F0000H – FFFFFH
	Video	Shadow for C0000H – C7FFFH
	System & Video *	Shadow for both

* Default setting

Cache controller

Input area	Possible inputs	Description
Cache	ENABLE *	486-internal cache in operation
	DISABLE	486-internal cache not in operation

* Default setting

Technical data of the CP 581 boards

Climatic conditions

Module	MLFB No.	Temperature	
		Operation	Storage
CP 581	6ES5 581-0EA11 6ES5 581-1EA11	+5 °C to +55 °C ¹⁾	-10 °C to +50 °C
CP 581/486	6ES5 581-0EB11 6ES5 581-1EB11	+5 °C to +55 °C ²⁾	-10 °C to +50 °C
CP 581/486	6ES5 581-0EB12 6ES5 581-1EB12	+5 °C to +55 °C ²⁾	-10 °C to +50 °C
CP 581/486	6ES5 581-0EC12 6ES5 581-1EC12	+5 °C to +55 °C ¹⁾	-10 °C to +50 °C

¹⁾ With and without forced ventilation

²⁾ +5 °C to +55 °C with forced ventilation
+5 °C to +40 °C without forced ventilation

Logic parameters for VGA:

VGA modes (Cirrus logic BIOS V1.2 with CLGD 5426 - cf. Cirrus logic BIOS V1.2, Cirrus Logic) of CP 581/486 with the following order numbers:

6ES5 581-0EB12
6ES5 581-1EB12
6ES5 581-0EC12
6ES5 581-1EC12

(The values listed in Table 4.2 in Volume 1/2 of the Manual apply to the CP 581/486 board with the order numbers 6ES5 581-0EA11/1EA11.)

Mode	Text/ graphics	Color/ BW	Columns/rows resolution	Number of colors	Horizontal frequency/ kHz	Vertical frequency/ Hz
0, 1	Text	Color	360 x 400	16	31.5	70
2, 3	Text	Color	720 x 400	16	31.5	70
4, 5	Graphics	Color	320 x 200	4	31.5	70
6	Graphics	Color	640 x 200	2	31.5	70
7	Text	BW	720 x 400	2	31.5	70
D	Graphics	Color	320 x 200	16	31.5	70
E	Graphics	Color	640 x 200	16	31.5	70
F	Graphics	BW	640 x 350	2	31.5	70
10	Graphics	Color	640 x 350	16	31.5	70
11	Graphics	Color	640 x 480	2	31.5	60
12	Graphics	Color	640 x 480	16	31.5	60
12+	Graphics	Color	640 x 480	16	37.9	72
13	Graphics	Color	320 x 200	256	31.5	70
14	Text	Color	1056 x 400	16	31.5	70
54	Text	Color	1056 x 350	16	31.5	70
55	Text	Color	1056 x 350	16	31.5	70
58, 6A	Graphics	Color	800 x 600	16	35.2	56
58, 6A	Graphics	Color	800 x 600	16	37.8	60
58, 6A	Graphics	Color	800 x 600	16	48.1	72
5C	Graphics	Color	800 x 600	256	35.2	56
5C	Graphics	Color	800 x 600	256	37.9	60
5C	Graphics	Color	800 x 600	256	48.1	72
5D	Graphics	Color	1024 x 768	16	35.5	87
5D	Graphics	Color	1024 x 768	16	48.3	60
5D	Graphics	Color	1024 x 768	16	56	70
5D	Graphics	Color	1024 x 768	16	58	72
5F	Graphics	Color	640 x 480	256	31.5	60
5F	Graphics	Color	640 x 480	256	37.9	72

Mode	Text/ graphics	Color/ BW	Columns/rows resolution	Number of colors	Horizontal frequency/ kHz	Vertical frequency/ Hz
60	Graphics	Color	1024 x 768	256	35.5	87 ¹⁾
60	Graphics	Color	1024 x 768	256	48.3	60
60	Graphics	Color	1024 x 768	256	56	70
60	Graphics	Color	1024 x 768	256	58	72
64	Graphics	Color	640 x 480	64K	31.5	60
64	Graphics	Color	640 x 480	64K	37.9	72
65	Graphics	Color	800 x 600	64K	35.2	56
65	Graphics	Color	800 x 600	64K	37.8	60
66	Graphics	Color	640 x 480	32K	31.5	60
66	Graphics	Color	640 x 480	32K	37.9	72
67	Graphics	Color	800 x 600	32K	31.5	56
6C	Graphics	Color	1280 x 1024	16K	48	87 ¹⁾
6D	Graphics	Color	1280 x 1024	256K	48	87
6F	Graphics	Color	320 x 200	64K	31.5	70
70	Graphics	Color	320 x 200	16M	31.5	70
71	Graphics	Color	640 x 480	16M	31.5	60
74	Graphics	Color	1024 x 768	64K	35.5	87 ¹⁾

¹⁾ Interlaced mode

Ordering information

Designation	Order No.
CP 581, incl. MS-DOS in German ¹⁾	6ES5 581-0EA11 (without OSD) 6ES5 581-1EA11 (with OSD)
CP 581/486, incl. MS-DOS in German ¹⁾ (VGA memory 512 Kbyte)	6ES5 581-0EB11 (without OSD) 6ES5 581-1EB11 (with OSD)
CP 581/486, incl. MS-DOS in German ¹⁾ (VGA memory 1 Mbyte)	6ES5 581-0EB12 (without OSD) 6ES5 581-1EB12 (with OSD)
CP 581/486, incl. MS-DOS in German ¹⁾ (VGA memory 1 Mbyte, operation without fan)	6ES5 581-0EC12 (without OSD) 6ES5 581-1EC12 (with OSD)

¹⁾ Manual with MS-DOS diskettes

Designation	Order No.
CP 581/486 memory extension 8 Mbyte	6ES5 581-1HB11 (BIOS V1.3 and later)

Designation	Order No.
MS-DOS Upgrade English	6ES5 895-0BS22
MS-DOS Upgrade French	6ES5 895-0BS32

Part 3: Important Information on CP 581-DX4

Part 3 of this Supplement contains instructions for the user and technical information for the CP 581-DX4, Order No. 6ES5 581-0ED12 and 6ES5 581-0ED13.

Hardware description

Layout of the module

Figures 6 and 7 show the design of the basic board for the CP 581-DX4 for versions -0ED12 and -0ED13.

Changes to the switch settings S2 and S4:

To change the settings of the switches S2 and S4 on the version -0ED12 you must loosen the two screws on the guide rail for the memory card and remove the memory card (see Fig. 6). Once you have changed the settings, replace the guide rail again.

Using the main memory module

The CP 581-DX4 module is supplied without main memory (DRAM) (see Ordering Information). You should ensure that a DRAM module with the required memory capacity is inserted in socket X205 (see Figures 6 and 7) of the module before installing the module.

Onboard silicon disk

The CP 581-DX4 is supplied without an onboard silicon disk (OSD) (see Ordering Information).

The OSD is executed in the form of a DIMM module and must be inserted in the socket X204.

No settings are required in the BIOS Setup for the OSD. The CP 581-DX4 recognizes that an OSD is present during startup (message: "Silicon drive LW: installed on CP581").

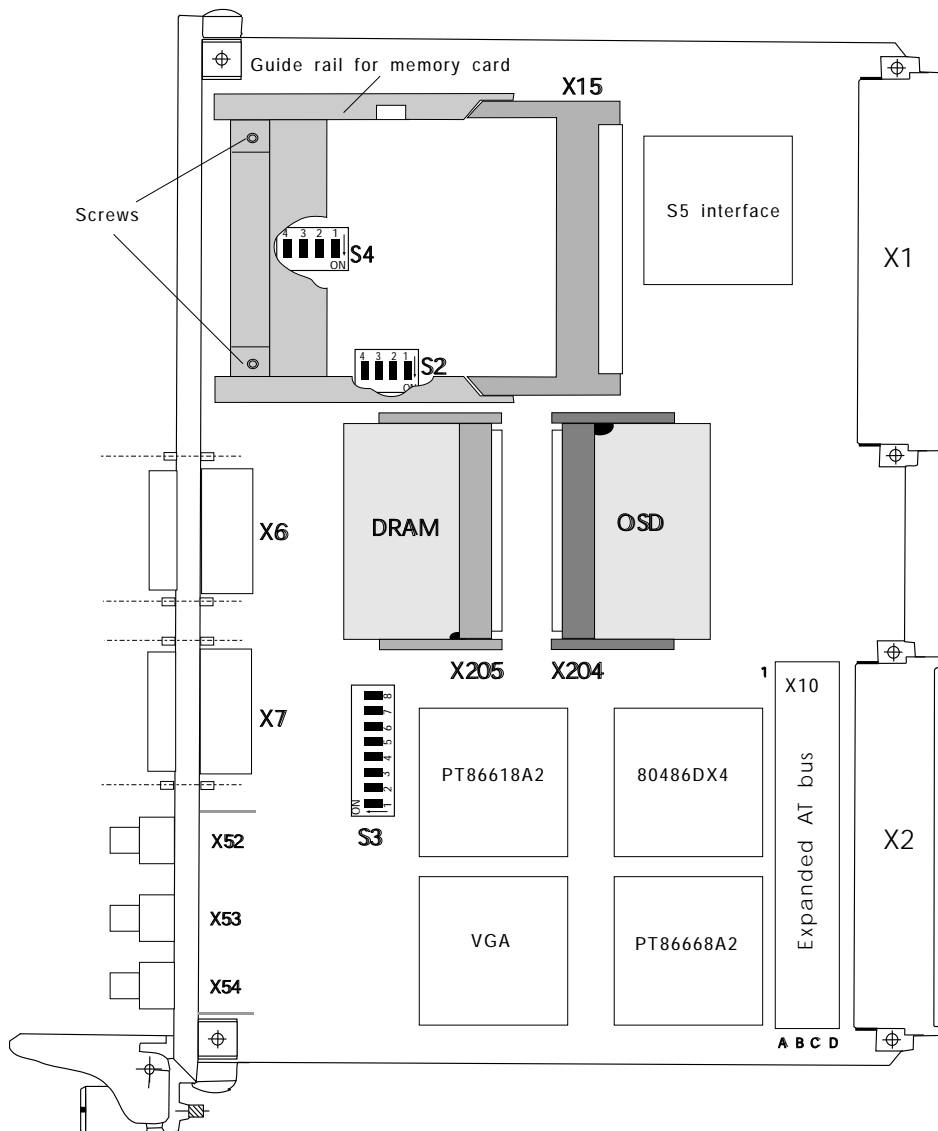

Fig. 6 Design of a CP 581 DX4 basic board, order no. 6ES5 581-0ED12

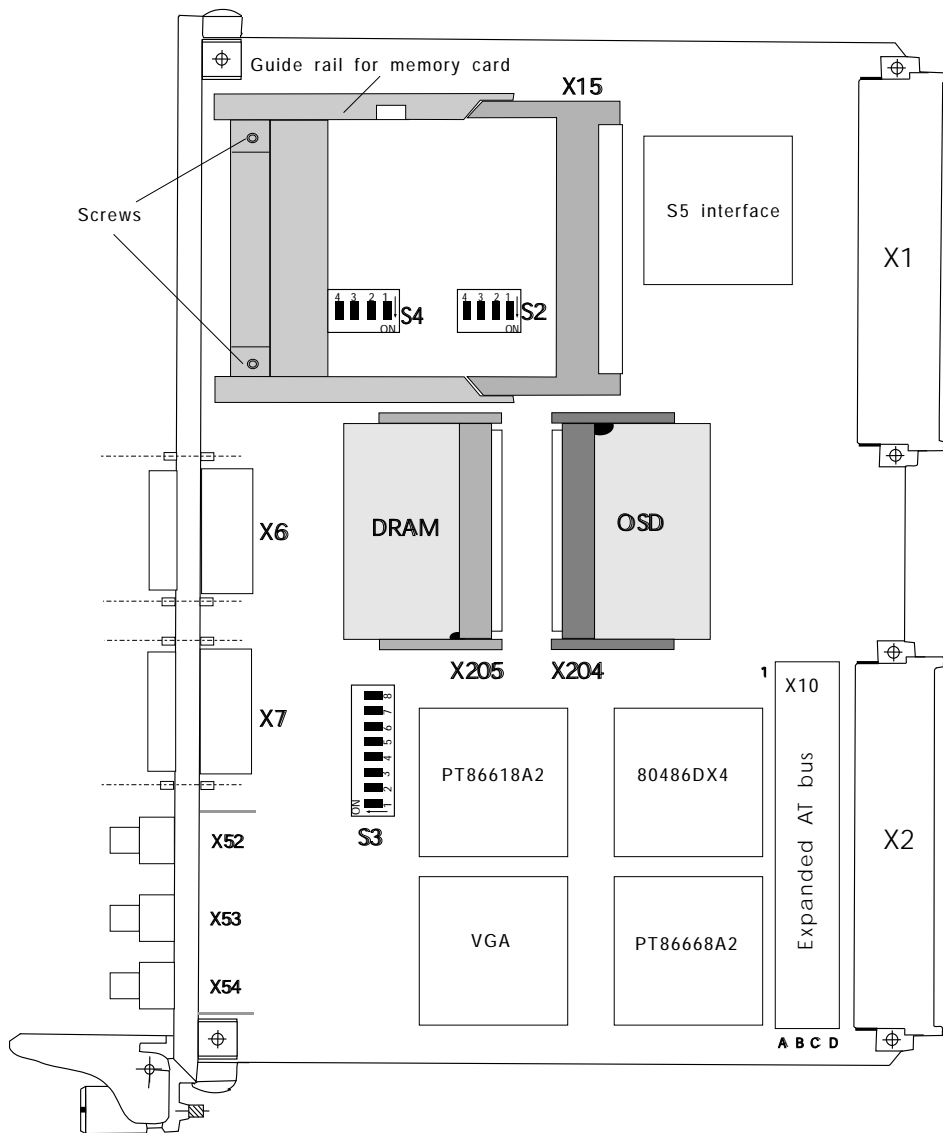

Fig. 7 Design of a CP 581 DX4 basic board, order no. 6ES5 581-0ED13

Description of the switch settings

Switch S2

No.	Function	ON	OFF	Effect
1	Processor frequency	x		80486DX4-75 (default setting)
			x	80486DX4-100
2	VGA operation	x		VGA switched on (default setting)
			x	VGA switched off
3	RI on COM 2	x		RI/COM 2
4			x	
3	Light pen at COM 2		x	Light pen operation (default setting)
4		x		

Note



Operation with a processor frequency of 100 MHz (80486DX4-100) is only permitted with forced ventilation.

Switch S4

No.	Function	ON	OFF	Effect
1	RxD COM 2 RS485/	x		RxD RS485 ¹⁾
			x	(default setting)
2	RxD COM 2 RS /422	x		RxD RS422 (default setting) ^{1) 2)}
			x	
3	RxD COM 3 RS485/	x		RxD RS485 ³⁾
			x	(default setting)
4	RxD COM 3 RS /422	x		RxD RS422 (default setting) ³⁾
			x	

- 1) Only either '1' or '2' may be set to ON, never both switches simultaneously
- 2) Mouse operation via RTI
- 3) Only either '3' or '4' may be set to ON, never both switches simultaneously

Switch S3

No.	Function	ON	OFF	Effect
1	COM 3 interrupt	x		Interrupt 4
			x	No interrupt (default setting)
2	COM 3 interrupt	x		Interrupt 5
			x	No interrupt (default setting)
3	COM 3 interrupt	x		Interrupt 10
			x	No interrupt (default setting)
4	COM 3 interrupt	x		Interrupt 11
			x	No interrupt (default setting)
5	COM 1 TTY send	X		TTY active (default setting)
			X	TTY passive
6	COM 1 TTY receive	X		TTY active (default setting)
			X	TTY passive
7	Keyboard	X		PG 750 keyboard
			X	Standard keyboard (default setting)
8	May not be changed			
			X	(default setting)

CP 581-DX4 memory assignments

In the assignment of the address area, a distinction is made between
- the memory address area and
- the I/O address area.

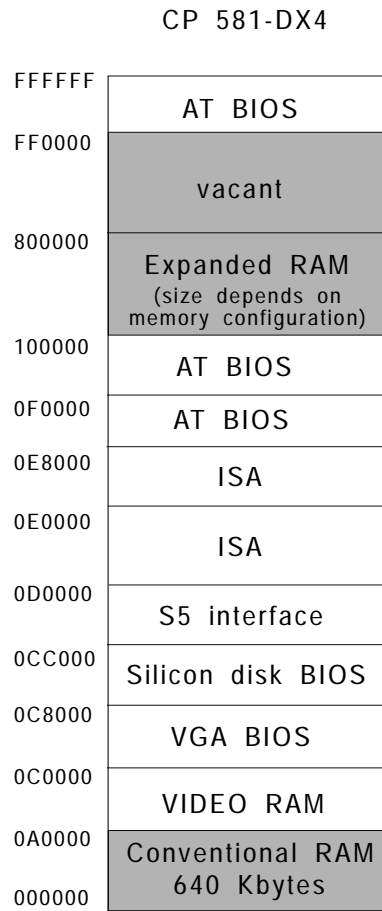

Fig. 8 Assignment of the CP 581 DX4 address area

Logic parameters for VGA

The VGA modes (Cirrus-Logic BIOS V1.xx with CLGD 5428/29) correspond to the modes of the CP 581-486 (see the "Technical data of the CP 581 boards" in Part 2 of this supplement).

BIOS Setup for CP 581-DX4

Switching on the PLC/cold restart

When you switch on the PLC or perform a cold restart on the CP 581, the BIOS starts a "Power On Self Test" (POST) and outputs the results in the POST window. The following screen appears:

```
PowerBIOS Version 1.00
Copyright (C) 1984-1995, Award Software, Inc.
?/?/96 - Picopower - Redwood - 314Q4000000

SIEMENS SIMATIC CP 581 DX4 Version 1.0

CPU Type . . . . . i486DX4 xx MHz
Math CoProcessor . . . . . Internal
Base Memory . . . . . 640 Kb
Extended Memory . . . . . 3072 Kb
BIOS Shadow RAM . . . . . Enabled
Video Shadow RAM . . . . . Enabled
Floppy Drives . . . . . 1 Found
Hard Drives . . . . . xxx 1)
Serial Ports . . . . . 4 Found
Parallel Ports . . . . . 1 Found
Testing Base Memory . . . . . 640 Kb
Testing Extended Memory . . . . . .xx Kb 2)

Press CTRL-ALT-ESC to enter setup
```

- 1) xxx = depends on the type of hard drive
- 2) depends on the memory configuration

Warm restart

When you warm restart the CP 581, the following screen appears:

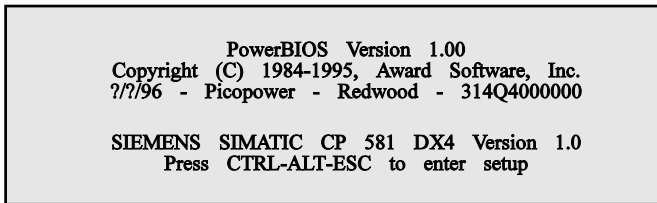

Changing the set BIOS parameters



If you want to change the default BIOS parameters (refer to Volume 1/2, Section 3.7 of the manual), activate the Setup selection page immediately after one of the previous screens using the following key combination:

CTRL and **ALT** and **ESC**

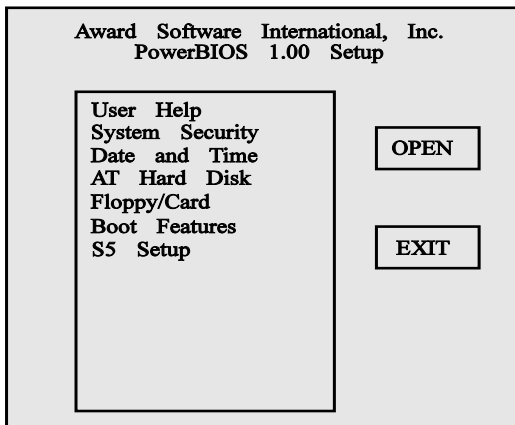
The BIOS Setup selection page is then displayed (see the following figure).



Using the cursor keys

 and  (cursor up or cursor down)

you select the Setup page in which you want to change parameters and confirm your selection with **RETURN**. Then the selected Setup page appears on the screen.

Use the following keys or key combinations to select and change individual Setup parameters:

- Tab key  :

With this key you position the cursor on the next option (= field with border) or on the next parameter within an option.

- Key combination  +  :

With this key you position the cursor on the previous option (= field with border) or on the previous parameter within an option.

- Cursor keys  and  ("cursor up" and "cursor down"):

With these keys you change the settings of a parameter: either the numerical value (e.g. the hours for the time of day) or another alternative for a parameter (e.g. the parameter "Mode" in the option PAGE FRAMES in the S5 Setup).

- Spacebar :

With the spacebar you select one or more parameters in a parameter group. The individual parameters in a group are identified by "[]". You can recognize whether a parameter is selected or not by means of the check mark '√' in the square brackets.

- **RETURN** key:
With this key you confirm that an option has been selected.
- **ESC** key:
When you have selected a Setup page, you can return to the selection menu at any time using this key.

Setup pages:

This section describes the individual Setup pages which you can display via the selection menu in order to change parameters.

- **User Help:**

The screenshot shows a 'User Help' screen with the following content:

- Header: User Help
- Instruction: Use TAB / SHFT-TAB Keys to toggle trough items
- Buttons and instructions:
 - OK**: Press ENTER to save changes and close page
 - CANCEL**: Select and press ENTER or press ESC to close page without saving
 - DEF**: Select and press ENTER to load default values in page
- Input field examples:
 - Checkbox**: [] Option
 - Radio Button**: (*) Option 1, () Option 2, () Option 3
 - List Box**: Option 1, Option 2, Option 3
 - Edit Box**: 0
- Additional instructions:
 - Use SPACE Bar to enable / disable checkbox option
 - Use Cursor Keys to select an option
 - Use Cursor Keys or type in the number or string

- **System security:**

System Security

Device Security

[] Floppy Disk Read Only

[] Hard Disk Read Only

OK

CANCEL

Password

[] Enter Setup

[] System Boot

Parameter group "Password":

"Enter Setup":

You can protect the Setup settings by entering a password under the option "Enter Setup".

If Setup recognizes that a password has been entered when it starts up, it will only allow the date and time to be changed if an incorrect password is entered.

"System Boot":

You can also enter a second password under the option "System Boot" to protect the CP 581-DX4 startup. The requirement for this is that you have assigned a password for "Enter Setup".

If Setup recognizes that a password has been entered for booting, you can only boot the CP if you enter the correct password. Setup allows three attempts at entering the password. If you enter an incorrect password three times, you can only attempt it again after switching the mains power off and on again.

- **Date and Time:**

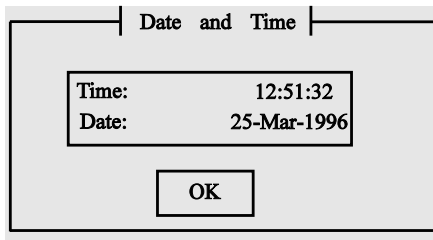

Using the "Date and Time" page you can set the current date and time.

- **AT Hard Disk:**

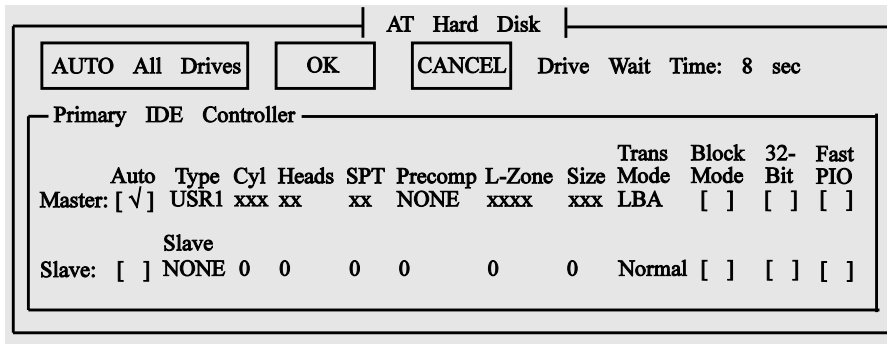

Using the "AT Hard Disk" page you can set the hard disk parameters for drive C:.

As default, the option "Auto Ide Detection" is switched on ("Auto" = "[√]"). This option determines the hard disk parameters **automatically**.

With this option, the LBA Mode is also set for hard disks which can work in LBA Mode. For hard disks which cannot work in LBA Mode, the normal mode is set.

Note



If you use a hard disk \geq 512 Mbytes which was formatted in normal mode, you must switch off the option "Auto Ide Detection" ("Auto" = "[]") and enter the values as hard disk parameters which were used when the hard disk was formatted, e.g. for 6ES5 581-3LA11: "1050Cyl., 16 H., SPT 63, Trans Mode: normal".

CP 581/386 and CP 581/486 generally format the hard disk in normal mode.

If an OSD (onboard silicon disk) is inserted, this can be addressed as drive D: (with a hard disk) or C: (without a hard disk). The OSD is not displayed in the AT Hard Disk page.

The transfer modes "Block Mode" and "32-Bit" are used for faster data exchange. Owing to the ISA interface, however, Block Mode and 32-Bit Mode do not improve performance significantly.

Following a CMOS error the default setting "Auto" (Auto Ide Detection) is switched on.

The options in the parameter group "Slave" are switched off as the default and **must not be changed**.

The option "**Fast PIO**" must not be set.

The value for "Drive Wait Time" is a monitoring time when waiting for a drive to start up. To change the start-up time you can set the existing preset of 8 seconds to a new value in the range from 0 to 15 seconds.

- **Floppy/Card:**

Floppy/Card	
Drive A:	Drive B:
<input type="radio"/> NONE	<input checked="" type="radio"/> NONE
<input type="radio"/> 360 Kb	<input type="radio"/> 360 Kb
<input type="radio"/> 1.2 Mb	<input type="radio"/> 1.2 Mb
<input type="radio"/> 720 Kb	<input type="radio"/> 720 Kb
<input checked="" type="radio"/> 1.44 Mb	<input type="radio"/> 1.44 Mb
<input type="radio"/> Memcard	<input type="radio"/> Memcard

OK
CANCEL

Using the "Floppy/Card" page you set the parameters for the drives A: and B:.
The parameters marked with "("*)" are selected or preset.

- **Boot Features:**

OK CANCEL DEFAULT

Boot Sequence	Keyboard State
<input checked="" type="radio"/> A:, C:	<input type="checkbox"/> Typematic Settings Enabled
<input type="radio"/> C:, A:	Typematic Rate: 6 (char/s)
	Typematic Delay: 250 (msec)
	<input checked="" type="checkbox"/> Num Lock On
Halt On ...	System Memory
<input checked="" type="checkbox"/> Halt on all Errors Except for ...	<input checked="" type="checkbox"/> Quick Memory Test
<input type="checkbox"/> Keyboard Errors	
<input type="checkbox"/> Disk Errors	

Using the "Boot Features" page you set the boot parameters. The parameters marked with "("*)" and "[√]" are selected or preset.

Parameter group "**Halt On**":

Independent of the setting the module **always** runs through this. According to the selections, any errors occurring during booting are displayed.

- **S5 Setup:**

S5 Setup	
<p>CONTROL</p> <p><input type="checkbox"/> S5-Interface</p> <p><input checked="" type="checkbox"/> Page frames</p> <p><input type="checkbox"/> I/O Pointer</p> <p><input type="checkbox"/> Pointer read</p>	<p>COMMUNICATION FLAGS</p> <p><input type="checkbox"/> 0 - 31 (F200H-F21FH)</p> <p><input type="checkbox"/> 32 - 63 (F220H-F23FH)</p> <p><input type="checkbox"/> 64 - 95 (F240H-F25FH)</p> <p><input type="checkbox"/> 96 - 127 (F260H-F27FH)</p> <p><input type="checkbox"/> 128 - 159 (F280H-F29FH)</p> <p><input type="checkbox"/> 160 - 191 (F2A0H-F2BFH)</p> <p><input type="checkbox"/> 192 - 223 (F2C0H-F2DFH)</p> <p><input type="checkbox"/> 224 - 255 (F2E0H-F2FFH)</p>
<p>PAGE FRAMES</p> <p>FRAMES: 4</p> <p>Mode: Paged</p> <p>Page Number: 0</p> <p>Base: F400H</p>	<p><input type="button" value="OK"/></p> <p><input type="button" value="CANCEL"/></p>
<p>I/O-POINTER</p> <p>Range: P-Peripherie</p> <p>Base: FX00H</p>	

The S5 Setup and its settings are described in detail in the CP 581 manual, Volume 1, Section 3.7.4.

Saving the changed Setup parameters

When you have set all the Setup parameters according to your hardware configuration and system requirements, you must then display the selection menu page again. To do this, exit the last Setup page you edited using ESC.

Now select the option **EXIT** in the selection menu and confirm your selection with **RETURN**. The "Setup Exit" page is then displayed (see following figure).

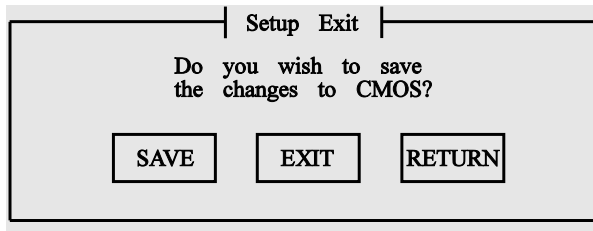

You can now select the following options:

- With **SAVE** you save all the changes you made in the Setup and reboot the system.
- With **EXIT** (or with **ESC**) you boot the system without saving the Setup changes (apart from date and time – these are entered immediately after a value is entered and the tab key is pressed).
- With **RETURN** you return to the selection menu.

CPLINK

When the RUN/STOP switch is set to STOP, CPLINK operation is active if CPLINK was already started on the connected PC/PG.

Remote Setup

Installation, connection cable:

For Remote Setup operation, connect an ANSI terminal or an ANSI terminal emulation via COM 1 or COM 2 of the CP 581-DX4.

If the connection is established when the CP runs up, you should keep the "Q" key pressed. As soon as the interfaces are synchronized a "U" appears on the screen of the terminal as the reply.

To connect the CP 581-DX4 to the terminal or the terminal emulation, use a connection cable with the assignments shown in the table below.

Signal	PIN	Connection	PIN	Signal
E1/GND	U	connected to	U	E1/GND
D2/RxD	2		2	D1/TxD
D1/TxD	3		3	D2/RxD
E2/GND	5		7	E2/GND
S2/RTS	7		5	U5/CTS
U2/CTS	8		4	S2/RTS
9-way Sub-D socket	PIN "U" = casing (shield) Length: max. 10 m		25-pin Sub-D connector	
PG/PC COM 2			CP 581-DX4 COM 1	
CP 581-DX4 COM 2			PG/PC COM 1	

Configuration of the interface:

8 data bits
 No parity
 1 stop bit
 Baud rate: 9600, 19200 or 38400
 ANSI

Run/STOP switch:

The position of the RUN/STOP switch is irrelevant for Remote Setup operation.

Starting the BIOS Setup:

From the terminal or the terminal emulation you can start the BIOS Setup via the **ESC** key.

If the RUN/STOP switch remains in STOP after you exit the Setup function, you can then start CPLINK operation by starting CPLINK on the PC/PG.

If you set the RUN/STOP switch to RUN after you exit the Setup function, the CP 581-DX4 is booted.

Note on formatting memory cards (RAM)

You can only format memory cards (RAM) with MS-DOS \geq 6.0 with the format command

"FORMAT A: /s"

(You cannot use the format parameter "/u".)

System software

When you use the CP 581-DX4 you must use the system software

6ES5 835-8MD01 from version **V2.5** onwards.

Changes

With CPDHB V2.6, the interface '0' is **no longer used as the default** with the CP 581-DX4.

Remedy:

Start CPDHB with the command

"CPDHB -ssnr x ", with $x = 0$ to 252

New software versions:

- InitCMOS.EXE from V1.6,
- CPLINK.EXE from V2.9.

Technical data of the CP 581-DX4

Basic board

Device-specific data:

Weight	Approx. 0.5 kg
Module format	Double Eurocard format (160 mm x 233.4 mm)
Front panel width	20 mm 1 1/3 standard slots
Backplane connector	ES 902, series 2, 48-pin
Front plugs: Keyboard/COM 2	Female connector, 26-way (D-subminiature, high-density)
COM 1/COM 3	Female connector, 26-way (D-subminiature, high-density)
RGB	3 x coax midi sockets

Power supply:

Supply voltages	+5 V, tolerance +/- 5% +24 V, tolerance + 25%/- 15%
-----------------	--

Current consumption:

Current consumption	CP 581-DX4	+5 V: max. 1.8 A - DX4-100 MHz max. 1.6 A - DX4-75 MHz +24 V: max. 0.1 A
Back-up current		Max. 0.05 mA

Safety

Standards	IEC 950 = EN 60 950 = DIN VDE 0805
Degree of protection	IP00 to IEC 529

Electromagnetic compatibility (EMC)

Radio interference suppression Limit class A	To CISPR 11
---	-------------

Noise immunity

Conducted interference on signal cables	To DIN VDE 0843, Part 4 = IEC 65(CO)39-1985(TC65) To IEC 801-4 (Burst): 1 kV
Noise immunity to discharges of static electricity	To IEC 801-2 (ESD): 6 kV
Noise immunity to external fields	To IEC 801-3: 3 V/m

Climatic conditions

Temperature

Operation (DX4/75 MHz with forced ventilation, DX-4/100 MHz without forced ventilation)	+5 to +55 °C (+41 to +122 °F)
Storage/transport	-10 to +60 °C (+14 to +140 °F)

Temperature gradient

Operation	Max. 10 K/h
Storage/transport	Max. 20 K/h

Relative humidity

Operation	8 to 80% at 25 °C (+77 °F), no condensation
Storage/transport	8 to 80% at 25 °C (+77 °F), no condensation

Altitude

(referred to mean sea level)

Operation	-50 m to 2 500 m
Storage/transport	Up to 10 000 m

Mechanical environmental conditions

Oscillations: Operation	Tested to IEC 68-2-6 10-58 Hz: amplitude 0.075 mm 58-150 Hz: acceleration 9.81 m/s ² (1 g)
Shock Operation	Tested to IEC 68-2-27 Half-sine: 150 m/s ² , 11 ms

Logic parameters of CP 581-DX4

Processor	80486-DX4
Coprocessor	Integrated
Chip set	Redwood/Cirrus Logic
Main memory	DRAM ¹⁾
Flash memory	Onboard silicon disk ¹⁾
Memory card interface	Flash card ¹⁾
Keyboard controller	82C42PC
COM 1/COM 2	82C552
COM 3	16C550
VGA controller	See "Logic parameters of VGA"
Video RAM	1 Mbyte
S5 interface	SIEMENS ASIC Max. 8-Kbyte dual-port RAM 256 interprocessor communication flags I/O area Watchdog

¹⁾ See Ordering Information

CP 581-DX4 ordering information

Designation	Order No.
CP 581-DX4	6ES5 581-0ED12
CP 581-DX4 incl. MS-DOS	
DRAM: 4 Mbyte 8 Mbyte 16 Mbyte 32 Mbyte	6ES7 478-1AM00-0AA0 6ES7 478-1AN00-0AA0 6ES7 478-1AP00-0AA0 6ES7 478-1AQ00-0AA0
Onboard silicon disk (4 Mbyte)	6ES7 478-1BM10-0AA0
Flash card 1 MB/5V 2 MB/5V 4 MB/5V	6ES5 374-2KK21 1) 6ES5 374-2LK21 1) 6ES5 374-2MK21 1)

¹⁾ Only for CP 581-DX4

Part 4: Replacement Pages for Volume 1/2

The following double pages contain small additions or corrections to complete pages in Volume 1/2 of the manual. You can replace the old pages in the manual with these corrected pages.

The numbers of the pages to be replaced can be found in the header on the following pages.

- Call SETUP program from the MS-DOS level:

You can call the SETUP program from the MS-DOS level in the following manners:

- a) When using a CP 581 with BIOS version < 2.0:
Enter the command **EXSETUP**.
- b) When using a CP 581 with BIOS version 2.0 or later or when using the CP 581/486:
You can call the SETUP program at any time by entering the key combination

CTRL and **ALT** and **ESC**

The EXSETUP program is no longer needed.
If it is still present on your hard disk, you should delete it.

- c) Regardless of the BIOS version and the CP 581 version:
Carry out a warm restart by entering the key combination:

CTRL and **ALT** and **DEL**

Following the power-on selftest, press the keys:

CTRL and **ALT** and **ESC**

- A form appears on the screen in which you can carry out the SETUP settings. Fig. 3.10 shows you the default values when the form is displayed.
- You can now access the required input field using the **cursor keys** and carry out the settings or select the options using the **"+/-" keys or the numeric keypad**.

- Table 3.28 shows which settings you can make. Once you have made the settings according to your device configuration, (press RETURN key following each modification), press key F10 and then key F5 to save the values. To abort the inputs made in the SETUP form without saving the modified parameters, press key F10 and then key F1.

Date: 09 June 1992	* 80x86SL ISA BIOS
Time: 00:00:00	SIEMENS
Drive A: 1.44 M, 3 1/2 in.	SIMATIC CP 581 VERSION x.x
Drive B: None	
Video: EGA/VGA	Base Memory: 640k
Post Messages: Maximize	Extended Memory: 3072k
Quick Boot: Disable	Expanded Memory: 0k
Halt On: No Errors	Other Memory: 384k
Boot Sequence A,C	Total Memory: 4096k
Auto Detect IDE Drive C:	Security: Disable

		CYLS.	HEADS	SECTORS	PRECOMP	LANDZONE
Drive C:	IDE (116 MB)**	762	8	39	None	761
Drive D:	None (0 MB)	0	0	0	0	0

Alt-F1 for Menu Help	PgDn = S5 Page	F10 exits
Page 01: Status Page		F2 change colors

* CP 581: x = 3 CP 581/486: x = 4

** The values depend on the drive used. When the CP 581 is delivered, the values are entered correctly. Note down the values in the screen form so you can enter them again if the data is lost following a crash.

Fig. 3.12 SETUP form (BIOS status page) with default settings

3.7.4 BIOS S5 Page

You can access the BIOS S5 page menu (see Fig. 3.13) from the BIOS status page using the key "PgDn".

Here you can enter the base interface number for data exchange with the S5 CPUs in the field "Number". You need not enter anything in this menu if you use the option "SSNR" in the load command for the CPDHB driver (please refer to Volume 2 of the manual).

CONTROL		COMMUNICATION FLAGS	
S5-Interface:	Enable	0 - 31 F200H-F21FH:	Disable
Page frames:	Enable	32 - 63 F220H-F23FH:	Disable
I/O-Pointer:	Disable	64 - 95 F240H-F25FH:	Disable
Pointer read:	Disable	96 - 127 F260H-F27FH:	Disable
		128 - 159 F280H-F29FH:	Disable
		160 - 191 F2A0H-F2BFH:	Disable
		192 - 223 F2C0H-F2DFH:	Disable
		224 - 255 F2E0H-F2FFH:	Disable
PAGE FRAMES			
Frames:	4		
Mode:	Paged		
Page Number:	0		
Base:	F400		
I/O-POINTER			
Range:	P-Periphery		
Base:	F000H		
Alt-F1 for Menu Help		PgUp = Status Page	F10 exits
Page 02: S5 Page		PgDn = Options Page	F2 change colors

Fig. 3.13 BIOS S5 page with default settings

The default settings are identified in the following tables by a *. These are loaded following failure of the back-up voltage.

Control

Table 3.29 Parameter and default settings with BIOS S5 page: control

Input field	Possible inputs	Description
S5-Interface	Disable ¹⁾	Access via S5 bus completely disabled.
	Enable ¹⁾	Access via S5 bus completely enabled.
Page frames	Disable	Access of page frames via S5 bus disabled.
	Enable *	Access of page frames via S5 bus enabled.
I/O-Pointer	Disable *	I/O-mapped access operations disabled.
	Enable	I/O-mapped access operations enabled.
Pointer read	Disable *	Reading of I/O address pointers disabled.
	Enable	Reading of I/O address pointers enabled.

¹⁾ Default setting: Disable in BIOS version V2.3 (386) and later and V1.3 (486) and later, see Section 3.7.3, Enable in BIOS versions prior to V2.3 (386) and prior to V1.3 (486).

4.2.8 Logic Parameters

Hard disk CP 581
Order No.: 6ES5 581-1LA11

2.5" hard disk ¹⁾

MTBF
Start/stop cycles

> 100 000 h
> 40 000

Floppy disk drive

Type
Floppy controller
MTBF

TEAC FD-05-HF (3.5", 1.44 Mbyte)
Intel 82077A
30 000 h (typical operation)

Interfaces

LPT/COM 4

16C452

- 1) Hard disk capacity depends on release version. The capacity is displayed in the SETUP form following booting with the SETUP setting "Auto Detect IDE DRIVE C" and "Drive C IDE".

4.3 AT-Slot Module

4.3.1 Device-Specific Data

Weight	Approx. 0.3 kg
Module format	Results in approx. double Eurocard format together with AT module (see also Section 4.3.9.)
Front panel width	20 mm, 1 1/3 standard slots
Backplane connector	None
Front connector	None

Note



A maximum of 2 AT-slot modules can be operated simultaneously in **one** CP 581 system.

4.3.2 Power Supply

Supply voltages	+5 V, tolerance $\pm 5\%$
-----------------	---------------------------

4.3.3 Current Consumption

Current consumption without AT module	+5 V: typically 0.3 A
Back-up current	Not required

Connection cables and adapters

Designation	Order No.
Connection cable for RTI (-3AA12)	6ES5 714-3xxx0
Y adapter (COM 1/COM 3)	6ES5 714-2AS01
Y adapter (keyboard/COM 2)	6ES5 714-2AT01
RGB/VGA adapter	6ES5 714-2AV01

Memory cards

	Note
	The flash EPROMS must be deleted when formatting and overwriting a flash memory card. The number of delete operations is currently limited to approx. 10 000 as a result of the physical characteristics of the flash EPROMS.

Designation	Order No.
Flash EPROM, 1 Mbyte	6ES5 374-2FK21
Flash EPROM, 2 Mbytes	6ES5 374-2FL21
Flash EPROM, 4 Mbytes	6ES5 374-2FM21
Flash EPROM, 8 Mbytes ¹⁾	6ES5 374-2FP21
Flash EPROM, 16 Mbytes ¹⁾	6ES5 374-2FS21

Designation	Order No.
"Memory cards" continued	
RAM, 512 Kbytes	6ES5 374-2AJ21
RAM, 1 Mbyte	6ES5 374-2AK21
RAM, 2 Mbytes	6ES5 374-2AL21

1) can be used with BIOS V2.3 (386) or V1.1 (486) upwards

CP 581 software

Designation	Order No.
CP 581 system software (international)	6ES5 835-8MD01

Length codes

Length of cable connector	Order No. extension for cable connector
	6ES5 736-2xxx0 Monitor cable
	6ES5 714-3xxx0 RTI cable
1.0 m 1.6 m 2.0 m	↑↑↑ BB0 BB6 BC0
2.5 m 3.0 m 3.2 m	BC5 BD0 BD2
5.0 m 8.0 m 10.0 m	BF0 BJ0 CB0
12.0 m 16.0 m 20.0 m	CB2 CB6 CC0
25.0 m 32.0 m 40.0 m	CC5 CD2 CE0
50.0 m	CF0
63.0 m 80.0 m	GG3 CJ0
100.0 m 120.0 m	DB0 DB2
160.0 m 200.0 m	DB6 DC0
250.0 m	DC5

S5-115U

Designation	Order No.
Adapter casing for 2 slots	6ES5 491-0LB12
Adapter casing for 4 slots	6ES5 491-0LD11

Note



You can obtain more information from the Catalogs ST 52.1, ST 52.3, ST 54.1 and ST 80 and in the manuals for the respective programmable controllers (see Reference Literature in Volume 2/2).

Remarks Form

Your comments and recommendations will help us to improve the quality and usefulness of our publications. Please take the first available opportunity to fill out this questionnaire and return it to Siemens.

Please do not forget to state the title, order number and release of your manual.

Title of Your Manual:
Order No. of Your Manual: Release:

Please give each of the following questions your own personal mark within the range from 1 (very good) to 5 (poor).

- 1. Do the contents meet your requirements?
- 2. Is the information you need easy to find?
- 3. Is the text easy to understand?
- 4. Does the level of technical detail meet your requirements?
- 5. Please rate the quality of the graphics/tables:

Additional comments:

.....

.....

.....

.....

.....

.....

.....

.....

.....

Siemens AG
AUT E 1163

D-76181 Karlsruhe
Federal Republic of Germany

From:
Your Name:
Your Title:
Company Name:
Street:
City, Zip Code:
Phone:

Please check any industry that applies to you:

- Automotive
- Chemical
- Electrical Machinery
- Food
- Instrument and Control
- Nonelectrical Machinery
- Pharmaceutical
- Plastic
- Pulp and Paper
- Textiles
- Transportation
- Petrochemical

Other