

Equipment Manual, 03/2006 Edition

sinamics

SINAMICS S120  
AC Drive

**SIEMENS**



# SIEMENS

## SINAMICS

### SINAMICS S120 Equipment Manual AC Drive

Manual

Foreword

---

System overview

---

1

Line-side power components

---

2

Power Modules

---

3

DC link components

---

4

Motor-side power  
components

---

5

Control Units

---

6

Supplementary system  
components and encoder  
system integration

---

7

Accessories

---

8

Cabinet design and EMC for  
components, Blocksize  
format

---

9

Service and maintenance

---

10

List of abbreviations/  
acronyms

---

A

## Safety Guidelines

This manual contains notices you have to observe in order to ensure your personal safety, as well as to prevent damage to property. The notices referring to your personal safety are highlighted in the manual by a safety alert symbol, notices referring only to property damage have no safety alert symbol. These notices shown below are graded according to the degree of danger.



---

### Danger

indicates that death or severe personal injury **will** result if proper precautions are not taken.

---



---

### Warning

indicates that death or severe personal injury **may** result if proper precautions are not taken.

---



---

### Caution

with a safety alert symbol, indicates that minor personal injury can result if proper precautions are not taken.

---

---

### Caution

without a safety alert symbol, indicates that property damage can result if proper precautions are not taken.

---

---

### Notice

indicates that an unintended result or situation can occur if the corresponding information is not taken into account.

---

If more than one degree of danger is present, the warning notice representing the highest degree of danger will be used. A notice warning of injury to persons with a safety alert symbol may also include a warning relating to property damage.

## Qualified Personnel

The device/system may only be set up and used in conjunction with this documentation. Commissioning and operation of a device/system may only be performed by **qualified personnel**. Within the context of the safety notes in this documentation qualified persons are defined as persons who are authorized to commission, ground and label devices, systems and circuits in accordance with established safety practices and standards.

## Prescribed Usage

Note the following:



---

### Warning

This device may only be used for the applications described in the catalog or the technical description and only in connection with devices or components from other manufacturers which have been approved or recommended by Siemens. Correct, reliable operation of the product requires proper transport, storage, positioning and assembly as well as careful operation and maintenance.

---

## Trademarks

All names identified by ® are registered trademarks of the Siemens AG. The remaining trademarks in this publication may be trademarks whose use by third parties for their own purposes could violate the rights of the owner.

## Disclaimer of Liability

We have reviewed the contents of this publication to ensure consistency with the hardware and software described. Since variance cannot be precluded entirely, we cannot guarantee full consistency. However, the information in this publication is reviewed regularly and any necessary corrections are included in subsequent editions.



# Foreword

## SINAMICS Documentation

The SINAMICS documentation is organized in 2 parts:

- General Documentation / Catalogs
- Manufacturer/Service Documentation

An overview of publications, which is updated on a monthly and also provides information about the language versions available, can be found on the Internet at:

[www.siemens.com/motioncontrol](http://www.siemens.com/motioncontrol)

Select the menu items "Support" → "Technical Documentation" → "Overview of Publications".

The Internet version of DOConCD (DOConWEB) is available under:

[www.automation.siemens.com/doconweb](http://www.automation.siemens.com/doconweb)

Information about training courses and FAQs (Frequently Asked Questions) can be found at the following website:

[www.siemens.com/motioncontrol](http://www.siemens.com/motioncontrol) under menu option "Support"

## Usage phases

Table 1 Usage phase and the available documents/tools

Usage phase	Tools
Orientation	SINAMICS S Sales Documentation
Planning/configuration	SIZER Configuration tool
Decision/ordering	SINAMICS S Catalogs
Installation/assembly	<ul style="list-style-type: none"><li>• SINAMICS S120 Equipment Manual for Control Units and Supplementary System Components</li><li>• SINAMICS S120 Equipment Manual Power Modules Booksize</li><li>• SINAMICS S120 Equipment Manual Power Modules Chassis</li><li>• SINAMICS S150 Operating Manual</li></ul>
Commissioning	<ul style="list-style-type: none"><li>• STARTER parameterization and commissioning tool</li><li>• SINAMICS S120 Getting Started</li><li>• SINAMICS S120 Commissioning Manual</li><li>• SINAMICS S120 CANopen Commissioning Manual</li><li>• SINAMICS S List Manual</li><li>• SINAMICS S150 Operating Manual</li></ul>
Usage/operation	<ul style="list-style-type: none"><li>• SINAMICS S120 Commissioning Manual</li><li>• SINAMICS S List Manual</li><li>• SINAMICS S150 Operating Manual</li></ul>

Usage phase	Tools
Maintenance/servicing	<ul style="list-style-type: none"><li>• SINAMICS S120 Commissioning Manual</li><li>• SINAMICS S List Manual</li><li>• SINAMICS S150 Operating Manual</li></ul>

### Target group

This Manual addresses planners, installation technicians, design engineers.

### Benefits

This manual provides information on the components and functions of devices so that the target group is capable of installing, setting up, testing, operating, and troubleshooting the devices safely and correctly.

### Standard scope

This documentation only describes the functionality of the standard version. Extensions or changes made by the machine tool manufacturer are documented by the machine tool manufacturer.

Other functions not described in this documentation might be able to be executed in the drive system. This does not, however, represent an obligation to supply such functions with a new control or when servicing.

Further, for the sake of simplicity, this documentation does not contain all detailed information about all types of the product and cannot cover every conceivable case of installation, operation or maintenance.

## Technical Support

If you have any questions, please get in touch with our Hotline:

### European and African time zones

A&D Technical Support

Tel.: +49 (0) 180 / 5050 - 222

Fax: +49 (0) 180 / 5050 - 223

Internet: [www.siemens.com/automation/support-request](http://www.siemens.com/automation/support-request)

E-mail: [adsupport@siemens.com](mailto:adsupport@siemens.com)

### Asian and Australian time zones

A&D Technical Support

Tel.: +86 1064 719 990

Fax: +86 1064 747 474

Internet: [www.siemens.com/automation/support-request](http://www.siemens.com/automation/support-request)

E-mail: [adsupport@siemens.com](mailto:adsupport@siemens.com)

### American time zone

A&D Technical Support

Tel.: +1 423 262 2522

Fax: +1 423 262 2289

Internet: [www.siemens.com/automation/support-request](http://www.siemens.com/automation/support-request)

E-mail: [adsupport@siemens.com](mailto:adsupport@siemens.com)

---

### Note

Country telephone numbers for technical support are provided under the following Internet address:

[www.siemens.com/automation/service&support](http://www.siemens.com/automation/service&support)

---

## Questions about the Manual

If you have any questions (suggestions, corrections) regarding this documentation, please fax or e-mail us at:

Fax: +49 (0) 9131 / 98 - 63315

E-mail: [motioncontrol.docu@siemens.com](mailto:motioncontrol.docu@siemens.com)

Fax form: Refer to the reply form at the end of this manual

## Internet address for SINAMICS

[www.siemens.com/sinamics](http://www.siemens.com/sinamics).

## EC Declaration of Conformity

The EC Declaration of Conformity for the EMC Directive can be found/obtained from:

- in the Internet:  
[www.ad.siemens.de/csinfo](http://www.ad.siemens.de/csinfo)  
under Product/Order No. 15257461
- with the responsible branch office of the A&D MC Business Division of Siemens AG.

## ESD information

---



### Caution

Electrostatic sensitive devices (ESDs) are individual components, integrated circuits, or boards that may be damaged by either electrostatic fields or electrostatic discharge.

Regulations for handling ESD components:

When handling components, make sure that personnel, workplaces, and packaging are well earthed.

Personnel may only come into contact with electronic components, if

- They are grounded with an ESD wrist band, or
- They are in ESD areas with conductive flooring, ESD shoes or ESD grounding straps.

Electronic boards should only be touched if absolutely necessary. They must only be handled on the front panel or, in the case of printed circuit boards, at the edge.

Electronic boards must not come into contact with plastics or items of clothing containing synthetic fibers.

Boards must only be placed on conductive surfaces (work surfaces with ESD surface, conductive ESD foam, ESD packing bag, ESD transport container).

Do not place boards near display units, monitors, or television sets (minimum distance from screen: 10 cm).

Measurements must only be taken on boards when the measuring instrument is grounded (via protective conductors, for example) or the measuring probe is briefly discharged before measurements are taken with an isolated measuring device (for example, touching a bare metal housing).

---

---

## Safety information



---

### Danger

Commissioning shall not start until you have ensured that the machine in which the components described here are to be installed complies with Directive 98/37/EC.

SINAMICS S equipment must only be commissioned by suitably qualified personnel.

The personnel must take into account the information provided in the technical customer documentation for the product, and be familiar with and observe the specified danger and warning notices.

When electrical equipment and motors are operated, the electrical circuits automatically conduct a dangerous voltage.

Dangerous mechanical movements may occur in the system during operation.

All work on the electrical system must be carried out when the system has been disconnected from the power supply.

---



---

### Danger

Correct and safe operation of SINAMICS S drive units assumes correct transportation in the transportation packaging, correct long-term storage in the transport packaging, setup and installation, as well as careful operation and maintenance.

The details in the catalogs and proposals also apply to the design of special equipment versions.

In addition to the danger and warning information provided in the technical customer documentation, the applicable national, local, and system-specific regulations and requirements must be taken into account.

According to EN 61800-5-1 and UL 508, only protective extra-low voltages (PELVs) up to 30 V AC or 42.4 V DC may be connected to all connections and terminals.

---



---

### Danger

As part of routine tests, SINAMICS S components will undergo a voltage test in accordance with EN 61800-5-1. Before the voltage test is performed on the electrical equipment of industrial machines to EN 60204-1, Section 19.4, all connectors of SINAMICS equipment must be disconnected/unplugged to prevent the equipment from being damaged.

Motors should be connected-up corresponding to the circuit diagram supplied with the motor (refer to the connection examples, Motor Modules). They must not be connected directly to the three-phase supply because this will damage them.

---

---

**Note**

When operated in dry areas, SINAMICS equipment conforms to the Low-Voltage Directive 73/23/EEC.

---

---

**Note**

SINAMICS equipment fulfills, in the configuration specified in the associated EC Declaration of Conformance and when the EMC Mounting Guidelines is consequently implemented, Order No. 6FC 5297-□AD30-0AP□, EMC Directive 89/336/EEC.

---



---

**Warning**

Operating the equipment in the immediate vicinity (< 1.8 m) of mobile telephones with a transmitter power of > 1 W may lead to incorrect operation.

---

# Table of contents

	Foreword .....	iii
<b>1</b>	<b>System overview.....</b>	<b>1-1</b>
1.1	Field of application .....	1-1
1.2	Versions .....	1-2
1.3	Platform concept and Totally Integrated Automation.....	1-2
1.4	Overview, SINAMICS S120 AC Drive.....	1-3
1.5	Components, SINAMICS S120 AC Drive .....	1-5
1.6	System data .....	1-6
1.7	Standards.....	1-8
<b>2</b>	<b>Line-side power components.....</b>	<b>2-1</b>
2.1	Introduction .....	2-1
2.2	Line connection variants .....	2-3
2.2.1	Methods of line connection .....	2-3
2.2.2	Operation of the Line Connection Components on the Supply Network .....	2-4
2.2.3	Operation of the Line Connection Components via an Autotransformer .....	2-5
2.2.4	Operation of the Line Connection Components via an Isolating Transformer.....	2-6
2.2.5	Line Connection via a Residual-Current Circuit-Breaker .....	2-7
2.3	Line filter.....	2-8
2.3.1	Description .....	2-8
2.3.2	Safety information .....	2-8
2.3.3	Dimension drawing, Blocksize .....	2-9
2.3.4	Dimension drawing, Chassis.....	2-10
2.3.5	Installation.....	2-11
2.3.6	Electrical Connection .....	2-13
2.3.7	Technical data, Blocksize line filter .....	2-14
2.3.8	Technical data, Chassis line filter .....	2-14
2.4	Line reactors .....	2-15
2.4.1	Description .....	2-15
2.4.2	Safety information .....	2-15
2.4.3	Dimension drawings, Blocksize line reactors.....	2-16
2.4.4	Dimension drawing, Chassis line reactor.....	2-20
2.4.5	Installation.....	2-22
2.4.6	Electrical Connection .....	2-26
2.4.7	Technical data, Blocksize .....	2-27
2.4.8	Technical data, Chassis.....	2-29

<b>3</b>	<b>Power Modules</b> .....	<b>3-1</b>
3.1	Power Modules Blocksize (PM340) .....	3-1
3.1.1	Description .....	3-1
3.1.2	Safety information .....	3-4
3.1.3	Interface description .....	3-7
3.1.3.1	Overview .....	3-7
3.1.3.2	Line supply connection.....	3-16
3.1.3.3	Motor connection.....	3-17
3.1.3.4	Connection to the option module, brake control .....	3-17
3.1.3.5	Braking resistor R1/R2.....	3-17
3.1.4	Dimension drawings.....	3-18
3.1.5	Mounting.....	3-25
3.1.6	Electrical installation.....	3-30
3.1.7	Technical data.....	3-30
3.2	Power Modules Chassis.....	3-42
3.2.1	Description .....	3-42
3.2.2	Safety information .....	3-43
3.2.3	Interface description .....	3-44
3.2.3.1	Overview .....	3-44
3.2.3.2	Sample connection.....	3-46
3.2.3.3	Terminal Block X9.....	3-47
3.2.3.4	DCPS, DCNS connection for a dv/dt filter.....	3-47
3.2.3.5	X41 EP terminal / temperature sensor connection .....	3-48
3.2.3.6	DRIVE-CLiQ Interface X400-X402.....	3-48
3.2.3.7	Meaning of the LEDs on the Power Module .....	3-49
3.2.4	Dimension drawings.....	3-50
3.2.5	Mounting the CU310 in the Power Module Chassis .....	3-52
3.2.6	Electrical connection .....	3-53
3.2.7	Technical data.....	3-54
3.2.7.1	Characteristics .....	3-56
3.2.7.2	Current de-rating as a function of the pulse frequency.....	3-57
<b>4</b>	<b>DC link components</b> .....	<b>4-1</b>
4.1	Blocksize .....	4-1
4.1.1	Braking resistors .....	4-1
4.1.1.1	Description .....	4-1
4.1.1.2	Safety information .....	4-1
4.1.1.3	Dimension drawings.....	4-3
4.1.1.4	Mounting.....	4-5
4.1.1.5	Technical data.....	4-6
4.2	Chassis.....	4-8
4.2.1	Braking Modules .....	4-8
4.2.1.1	Description .....	4-8
4.2.1.2	Safety information .....	4-9
4.2.1.3	Braking Module for frame size FX.....	4-10
4.2.1.4	Braking Module for type GX.....	4-11
4.2.1.5	Sample connection.....	4-12
4.2.1.6	Braking resistor connection X1 .....	4-12
4.2.1.7	X21 digital inputs/outputs.....	4-13
4.2.1.8	S1 threshold value switch .....	4-13
4.2.1.9	Installing a Braking Module in a Power Module, frame size FX.....	4-14
4.2.1.10	Installing a Braking Module in a Power Module, frame size GX.....	4-17
4.2.1.11	Technical data.....	4-19



4.2.2	Braking resistors .....	4-20
4.2.2.1	Description .....	4-20
4.2.2.2	Safety information .....	4-20
4.2.2.3	Dimension drawing .....	4-21
4.2.2.4	Technical data .....	4-22
<b>5</b>	<b>Motor-side power components.....</b>	<b>5-1</b>
5.1	Motor reactors .....	5-1
5.1.1	Blocksize .....	5-1
5.1.1.1	Description .....	5-1
5.1.1.2	Safety information .....	5-1
5.1.1.3	Dimension drawings.....	5-2
5.1.1.4	Mounting .....	5-7
5.1.1.5	Electrical connection .....	5-12
5.1.1.6	Technical data.....	5-13
5.1.2	Chassis .....	5-16
5.1.2.1	Description .....	5-16
5.1.2.2	Safety information .....	5-16
5.1.2.3	Dimension drawing .....	5-17
5.1.2.4	Technical data.....	5-18
5.2	Sinusoidal filter .....	5-19
5.2.1	Chassis .....	5-19
5.2.1.1	Description .....	5-19
5.2.1.2	Safety information .....	5-19
5.2.1.3	Dimension drawing .....	5-20
5.2.1.4	Technical data.....	5-21
5.3	dv/dt filter.....	5-22
5.3.1	Chassis .....	5-22
5.3.1.1	Description .....	5-22
5.3.1.2	Safety information .....	5-22
5.3.1.3	Interface description.....	5-24
5.3.1.4	Connection of the dv/dt filter .....	5-25
5.3.1.5	Dimension drawing, dv/dt reactor .....	5-26
5.3.1.6	Dimension drawing, limiting network .....	5-28
5.3.1.7	Technical data.....	5-29
<b>6</b>	<b>Control Units.....</b>	<b>6-1</b>
6.1	Introduction .....	6-1
6.2	Control Unit CU310 DP (PROFIBUS).....	6-5
6.2.1	Description .....	6-5
6.2.2	Safety information .....	6-6
6.2.3	Interface description.....	6-7
6.2.3.1	Overview .....	6-7
6.2.3.2	Sample connection .....	6-8
6.2.3.3	X100 DRIVE-CLiQ interface .....	6-9
6.2.3.4	X120 EP terminals / temperature sensor connection .....	6-9
6.2.3.5	X121 digital inputs/outputs.....	6-10
6.2.3.6	Electronics power supply X124.....	6-11
6.2.3.7	X21 PROFIBUS .....	6-11
6.2.3.8	X23 HTL/ TTL encoder interface.....	6-12
6.2.3.9	PROFIBUS address switches .....	6-13
6.2.3.10	X22 serial interface (RS232).....	6-14
6.2.3.11	Measurement sockets T0, T1, and T2 .....	6-14
6.2.3.12	Slot for the CompactFlash card .....	6-15
6.2.3.13	Description of the LEDs on the Control Unit 310 DP .....	6-16

6.2.4	Dimension drawing.....	6-17
6.2.5	Mounting the CU310 on the Power Module Blocksize.....	6-18
6.2.6	Mounting the CU310 in the Power Module Chassis .....	6-20
6.2.7	Technical data.....	6-21
6.3	Control Unit CU310 PN (PROFINET) .....	6-22
6.3.1	Description .....	6-22
6.3.2	Safety information .....	6-22
6.3.3	Interface description.....	6-23
6.3.3.1	Overview .....	6-23
6.3.3.2	Sample connection.....	6-24
6.3.3.3	X100 DRIVE-CLiQ interface.....	6-25
6.3.3.4	X120 EP terminals / temperature sensor connection .....	6-25
6.3.3.5	X121 digital inputs/outputs.....	6-26
6.3.3.6	Electronics power supply X124.....	6-27
6.3.3.7	X200 - X201 PROFINET .....	6-27
6.3.3.8	X23 HTL/ TTL encoder interface.....	6-28
6.3.3.9	X22 serial interface (RS232).....	6-28
6.3.3.10	Measurement sockets T0, T1, and T2 .....	6-29
6.3.3.11	Description of the LEDs on the Control Unit 310 PN .....	6-30
6.3.4	Dimension drawing.....	6-31
6.3.5	Mounting the CU310 on the Power Module Blocksize.....	6-32
6.3.6	Technical data.....	6-33
6.4	Control Unit Adapter 31 (CUA31) .....	6-34
6.4.1	Description .....	6-34
6.4.2	Safety Information .....	6-34
6.4.3	Interface description.....	6-35
6.4.3.1	Overview .....	6-35
6.4.3.2	X200 - X202 DRIVE-CLiQ interface.....	6-36
6.4.3.3	X224 electronics power supply .....	6-37
6.4.3.4	X210 EP terminals / temperature sensor connection .....	6-37
6.4.3.5	Description of the LEDs at the Control Unit Adapter 31 .....	6-38
6.4.4	Dimension drawing.....	6-38
6.4.5	Mounting.....	6-39
6.4.6	Technical data.....	6-40
<b>7</b>	<b>Supplementary system components and encoder system integration .....</b>	<b>7-1</b>
7.1	Basic Operator Panel 20 (BOP20).....	7-1
7.1.1	Description .....	7-1
7.1.2	Interface description.....	7-1
7.1.3	Mounting.....	7-4
7.1.4	Technical data.....	7-5
7.2	Terminal Module 31 (TM31).....	7-5
7.2.1	Description .....	7-5
7.2.2	Safety information .....	7-5
7.2.3	Interface description.....	7-6
7.2.3.1	Overview .....	7-6
7.2.3.2	Sample connection.....	7-7
7.2.3.3	X500 and X501 DRIVE-CLiQ interface.....	7-8
7.2.3.4	Electronics power supply X524.....	7-8
7.2.3.5	Digital inputs X520 .....	7-9
7.2.3.6	Digital inputs X530 .....	7-10
7.2.3.7	Auxiliary voltage for the digital inputs X540 .....	7-11
7.2.3.8	Analog inputs X521 .....	7-12
7.2.3.9	S5 current/voltage changeover switch for analog inputs .....	7-12
7.2.3.10	Analog outputs/temperature sensor connection X522.....	7-13

7.2.3.11	X541 bidirectional digital inputs/outputs .....	7-14
7.2.3.12	Relay outputs X542.....	7-15
7.2.3.13	Description of the LEDs on the Terminal Module 31 (TM31) .....	7-15
7.2.4	Dimension drawing .....	7-16
7.2.5	Mounting .....	7-17
7.2.6	Electrical Connection .....	7-18
7.2.7	Technical data.....	7-20
7.3	Sensor Module Cabinet 10 (SMC10).....	7-21
7.3.1	Description .....	7-21
7.3.2	Safety information .....	7-22
7.3.3	Interface description.....	7-23
7.3.3.1	Overview .....	7-23
7.3.3.2	DRIVE-CLiQ interface X500 .....	7-24
7.3.3.3	X520 sensor system .....	7-25
7.3.3.4	Electronics power supply X524.....	7-26
7.3.3.5	Description of the LEDs on the SMC10.....	7-26
7.3.4	Dimension drawing .....	7-27
7.3.5	Mounting .....	7-28
7.3.6	Technical data.....	7-29
7.4	Sensor Module Cabinet 20 (SMC20).....	7-30
7.4.1	Description .....	7-30
7.4.2	Safety Information .....	7-30
7.4.3	Interface description.....	7-31
7.4.3.1	Overview .....	7-31
7.4.3.2	DRIVE-CLiQ interface X500 .....	7-32
7.4.3.3	X520 sensor system .....	7-33
7.4.3.4	Electronics power supply X524.....	7-34
7.4.3.5	Description of the LEDs on the SMC20 .....	7-34
7.4.4	Dimension drawing .....	7-35
7.4.5	Mounting .....	7-36
7.4.6	Technical data.....	7-37
7.5	Option modules, brake control.....	7-38
7.5.1	Introduction .....	7-38
7.5.2	Brake Relay.....	7-38
7.5.2.1	Description .....	7-38
7.5.2.2	Interface description.....	7-39
7.5.2.3	Dimension drawing .....	7-41
7.5.2.4	Technical data.....	7-41
7.5.3	Safe Brake Relay .....	7-42
7.5.3.1	Safety Information.....	7-42
7.5.3.2	Interface description.....	7-43
7.5.3.3	Dimension drawing .....	7-46
7.5.3.4	Mounting .....	7-47
7.5.3.5	Technical data.....	7-49
<b>8</b>	<b>Accessories .....</b>	<b>8-1</b>
8.1	DRIVE-CLiQ cabinet gland .....	8-1
8.1.1	Description .....	8-1
8.1.2	Safety Information .....	8-1
8.1.3	Interface description.....	8-2
8.1.3.1	Overview .....	8-2
8.1.4	Dimension drawing .....	8-3
8.1.5	Mounting .....	8-5
8.1.6	Technical data.....	8-6

8.2	DRIVE-CLiQ coupling .....	8-6
8.2.1	Description .....	8-6
8.2.2	Safety Information .....	8-6
8.2.3	Interface description .....	8-7
8.2.3.1	Overview .....	8-7
8.2.4	Dimension drawing .....	8-8
8.2.5	Installation .....	8-9
8.2.6	Technical data .....	8-9
8.3	Screening Kit .....	8-10
8.3.1	Dimension drawings .....	8-12
8.3.2	Mounting .....	8-18
<b>9</b>	<b>Cabinet design and EMC for components, Blocksize format .....</b>	<b>9-1</b>
9.1	Information .....	9-1
9.1.1	General .....	9-1
9.1.2	Safety information .....	9-2
9.2	Selection of Devices Required for Operating SINAMICS .....	9-3
9.2.1	General .....	9-3
9.2.2	Information about line disconnecting devices .....	9-3
9.2.3	Overcurrent protection using line fuses or circuit-breakers .....	9-3
9.2.4	Line Contactors .....	9-4
9.3	24 V DC Supply Voltage .....	9-5
9.3.1	General .....	9-5
9.3.2	Selecting power supply units .....	9-6
9.3.3	24 V component current consumption .....	9-7
9.3.4	Overcurrent Protection .....	9-8
9.4	Arrangement of components and equipment .....	9-9
9.4.1	General .....	9-9
9.4.2	Mounting .....	9-10
9.5	Information about Electromagnetic Compatibility (EMC) and Cable Routing .....	9-11
9.5.1	General .....	9-11
9.5.2	Cable Shielding and Routing .....	9-12
9.5.3	Equipotential bonding .....	9-15
9.6	Connection Methods .....	9-16
9.6.1	Screw terminals .....	9-16
9.7	Information on cabinet cooling .....	9-17
9.7.1	General .....	9-17
9.7.2	Ventilation .....	9-19
9.7.3	Power Loss of Components in Rated Operation .....	9-21
<b>10</b>	<b>Service and maintenance .....</b>	<b>10-1</b>
10.1	Safety information .....	10-1
10.2	Service and maintenance for components, Blocksize format .....	10-2
10.2.1	Replacing hardware components .....	10-2
10.2.2	Replacing the fan .....	10-2

---

10.3	Service and maintenance for Chassis format components .....	10-7
10.3.1	Maintenance.....	10-8
10.3.2	Installation equipment.....	10-9
10.3.3	Replacing components .....	10-10
10.3.3.1	Safety information .....	10-10
10.3.3.2	Replacing the Powerblock, Power Module, frame size FX.....	10-11
10.3.3.3	Replacing the Powerblock, Power Module, frame size GX .....	10-13
10.3.3.4	Replacing the fan, Power Module, frame size FX.....	10-15
10.3.3.5	Replacing the fan, Power Module, frame size GX.....	10-17
10.4	Spare parts.....	10-19
<b>A</b>	<b>List of abbreviations/acronyms .....</b>	<b>A-1</b>
A.1	List of abbreviations .....	A-1
	<b>Index.....</b>	<b>Index-1</b>



## System overview

### 1.1 Field of application

SINAMICS is the new family of drives from Siemens for industrial machines and plant construction. SINAMICS offers solutions for all drive tasks:

- Simple pump and fan applications in the process industry.
- Complex individual drives in centrifuges, presses, extruders, elevators, as well as conveyor and transport systems.
- Drive line-ups in textile, plastic film, and paper machines, as well as in rolling mill plants.
- Highly dynamic servo drives for machine tools, as well as packaging and printing machines.

Depending on the application, the SINAMICS range offers the ideal version for any drive task.

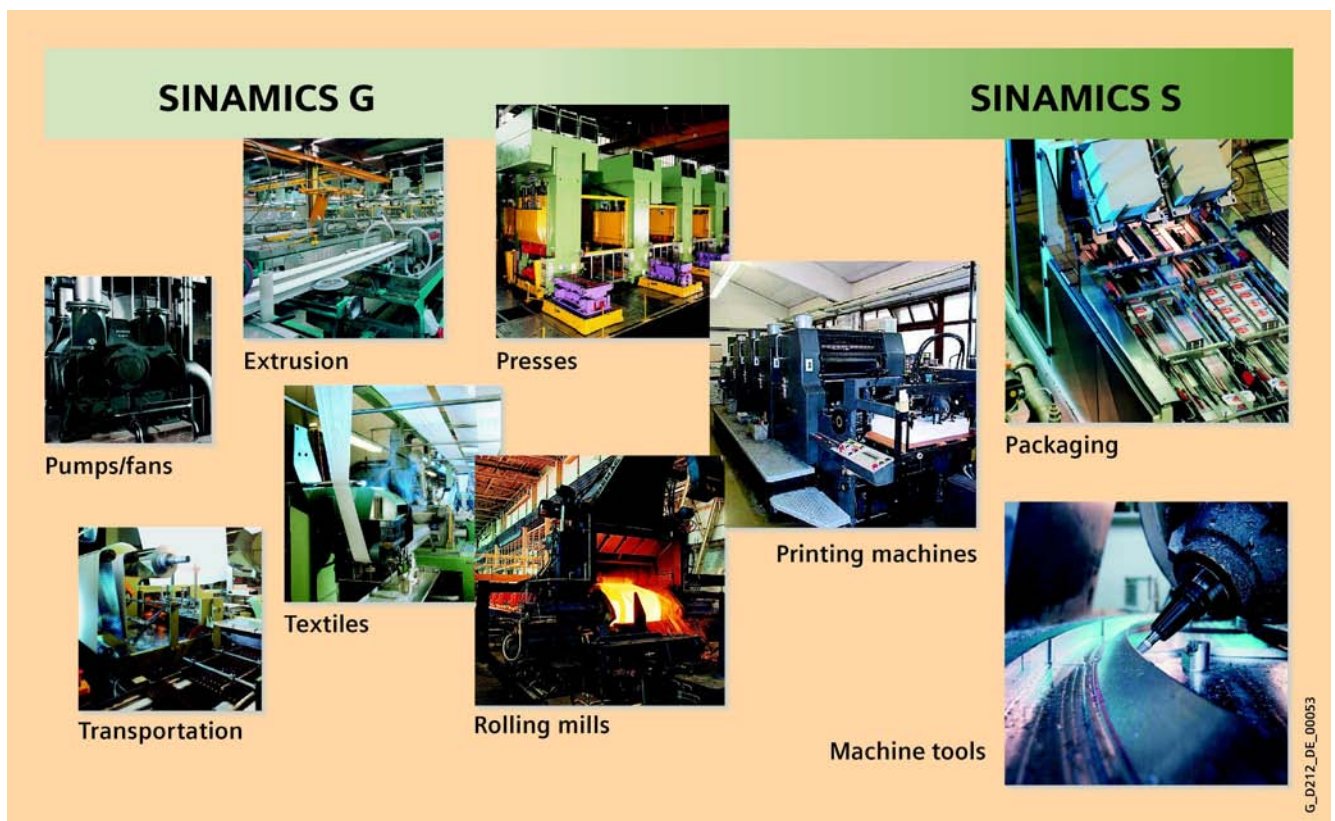

Figure 1-1 SINAMICS applications

## 1.2 Versions

SINAMICS offers different versions designed to meet a range of requirements:

- SINAMICS G is designed for standard applications with induction motors. These applications have less stringent requirements regarding the dynamics and accuracy of the motor speed.
- SINAMICS S handles complex drive tasks with synchronous/induction motors and fulfills stringent requirements regarding
  - Dynamics and accuracy,
  - Integration of extensive technological functions in the drive control system

## 1.3 Platform concept and Totally Integrated Automation

All SINAMICS versions are based on a platform concept. Joint hardware and software components, as well as standardized tools for design, configuration, and commissioning tasks ensure high-level integration across all components. SINAMICS handles a wide variety of drive tasks with no system gaps. The different SINAMICS versions can be easily combined with each other.

SINAMICS is a part of the Siemens "Totally Integrated Automation" concept. Integrated SINAMICS systems covering configuration, data storage, and communication at automation level ensure low-maintenance solutions with SIMATIC, SIMOTION, and SINUMERIK.

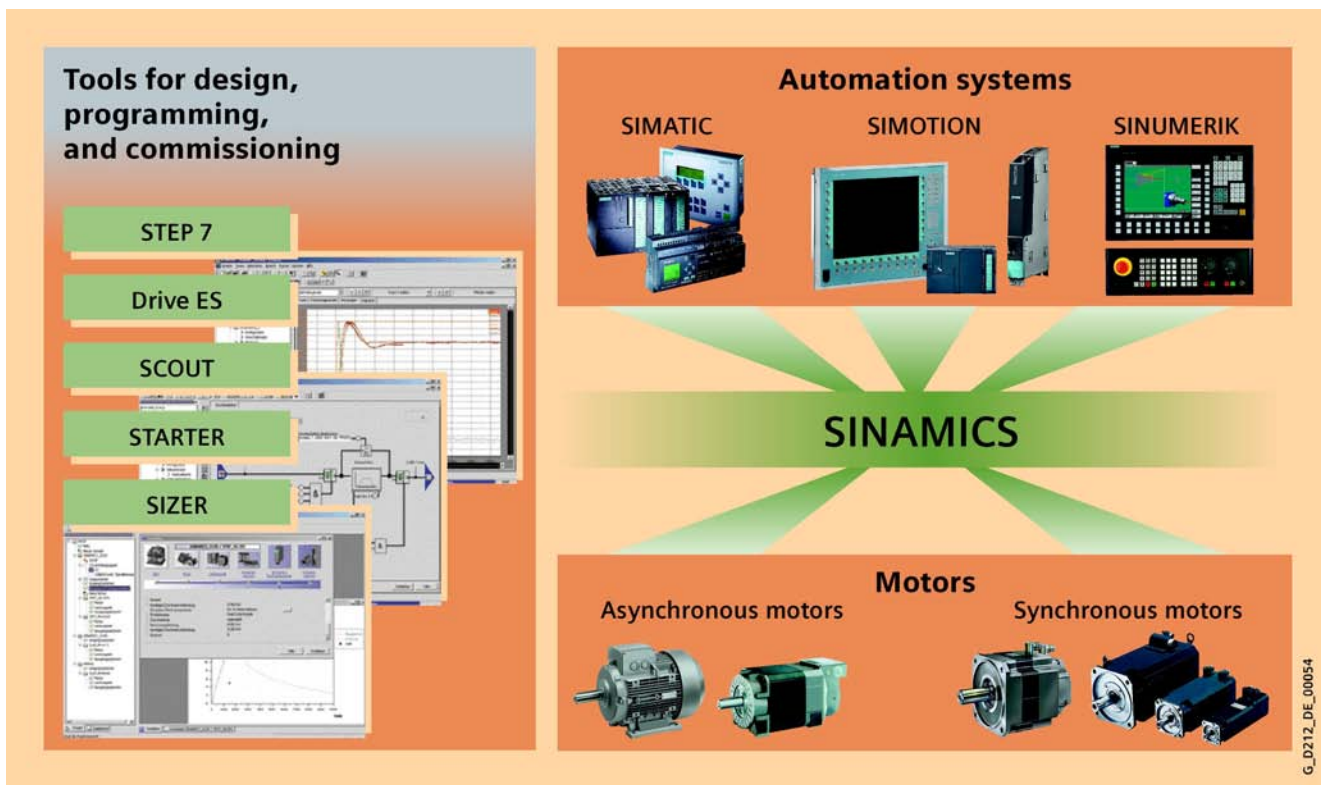

Figure 1-2 SINAMICS as part of the Siemens modular automation system



## 1.4 Overview, SINAMICS S120 AC Drive

SINAMICS S120 AC Drive is a modular drive system for individual axes and addresses sophisticated drive tasks for an extremely wide range of industrial applications.

Applications include:

- Machine concepts with a central drive (e.g. presses, printing, packaging)
- Modular machine concepts where the machine modules broken down to single axes
- Single-motor drives that when compared to standard drives have a high accuracy, stability and smooth running requirements in machinery and industrial plant construction
- Single-motor drives for transport applications (conveying, raising, lowering)
- Drives without regenerative feedback into the line supply (wire-drawing, extruding)
- Drive groups with high requirements placed on the availability (when the infeed fails, this may not cause all of the axes to fail)

The combination of a power unit (Power Module) and a Control Unit (CU) or a Control Unit Adapter form a single-motor drive in a compact design for machinery and plant construction.

SIZER, a high-performance engineering tool, makes it easier to choose and determine the optimum drive configuration. The drive can be simply commissioned a user-friendly fashion using the STARTER commissioning tool.

SINAMICS S120 AC Drive is supplemented by a wide range of motors. Whether synchronous or induction, whether rotary or linear motors, all motor types are supported by SINAMICS S120 AC Drive.

Configuration example

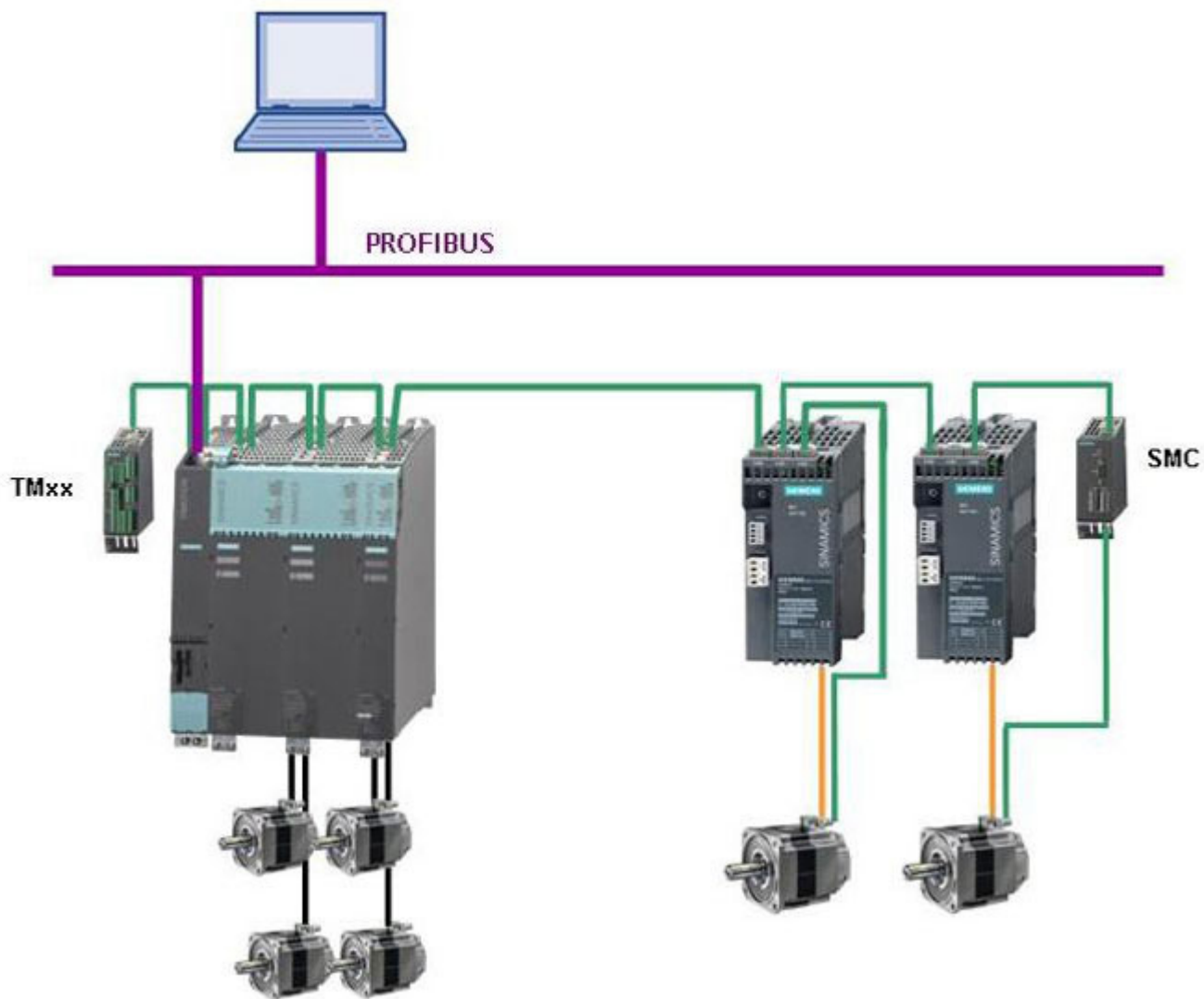

Figure 1-3 Configuration with multi-axis and single-axis drives

## 1.5 Components, SINAMICS S120 AC Drive

This overview includes components from SINAMICS S120 AC Drive.



Figure 1-4 Component overview, SINAMICS S120 AC Drive

The following power components are available:

- Line-side power components, such as fuses, contactors, reactors and line filters for switching the power supply and complying with EMC regulations.
- Power Modules, either with or without integrated line filter as well as integrated braking chopper to provide power to the connected motor

To address the required functions, SINAMICS S120 AC Drive is equipped with:

- Control Units that provide the drive and technological functions.
- Supplementary system components that enhance functionality and offer different interfaces for encoders and process signals.

The SINAMICS S120 AC Drive components were developed for installation in cabinets.

They have the following features and characteristics:

- Easy to handle, simple installation and wiring
- Practical connection system, cable routing in accordance with EMC requirements
- Standard design

## 1.6 System data

Table 1-1 General technical data

Electrical data	
Line connection voltage Blocksize format units  Chassis format units	1-ph. 200 V to 240 V AC $\pm$ 10%. 3-ph. 380 V to 480 V AC $\pm$ 10%. Installation altitudes up to 2000 m above sea level. De-rating is required above 2000 m. 3-ph. 380 V to 480 V AC $\pm$ 10%. Installation altitudes up to 2000 m above sea level. De-rating is required above 2000 m.
Line frequency	47 Hz to 63 Hz.
Output voltage Blocksize format units Chassis format units	0 V to line supply voltage for 3-ph. 380 V to 480 V AC units. 0 V to 0.78 V line supply voltage for 1-ph. 200 V to 240 V AC units. 0 V to line supply voltage for 3-ph. 380 V to 480 V AC units.
Electronics power supply Blocksize format units Chassis format units	24 V DC, -15/+20 %* *) If a motor holding brake is used, restricted voltage tolerances may have to be taken into account. 24 V DC, -15/+20 %.
Radio interference suppression • Blocksize format units – Standard – With line filter	No radio interference suppression. Category C2 acc. to EN 61800-3.

<b>Electrical data</b>	
<ul style="list-style-type: none"> <li>• Chassis format units <ul style="list-style-type: none"> <li>– Standard</li> <li>– With line filter</li> </ul> </li> </ul>	<p>Category C3 acc. to EN 61800-3. Category C2 acc. to EN 61800-3.</p>
Overvoltage category	III acc. to EN 60664-1
<b>Mechanical data</b>	
Vibratory load <ul style="list-style-type: none"> <li>• Long-term storage</li> <li>• Transport</li> <li>• Operation</li> </ul>	<p>Class 1M2 acc. to EN 60721-3-1 in transport packaging. Class 2M3 acc. to EN 60721-3-2 in transport packaging. Test values: 10 to 58 Hz 0.075 mm; 58 to 200 Hz 9.81 m/s<sup>2</sup> (1 g).</p>
Shock load <ul style="list-style-type: none"> <li>• Long-term storage</li> <li>• Transport</li> <li>• Operation</li> </ul>	<p>Class 1M2 acc. to EN 60721-3-1 in transport packaging. Class 2M3 acc. to EN 60721-3-2 in transport packaging. Test values: 147.15 m/s<sup>2</sup> (15 g) / 11 ms.</p>
<b>Ambient conditions</b>	
Degree of protection	IP20 or IPXXB acc. to EN 60529; Open Type acc. to UL 508.
Class of protection	Class I (with protective conductor) and Class III (PELV) to EN 61140.
Type of cooling	Internal air cooling, power units with forced air cooling using an integrated fan.
Permissible ambient temperature in operation for line-side components and Power Modules	0 °C to +40 °C without derating, maximum installation altitude 1000 m above sea level. 40 °C to +55 °C refer to derating characteristics.
Permissible ambient temperature in operation for Control Units and supplementary system components	0 °C to +55 °C; maximum installation altitude 1000 m above sea level. From an altitude of 1000 m, the max. ambient temperature decreases by 7 °C every 1000 m.
Climatic ambient conditions <ul style="list-style-type: none"> <li>• Storage <sup>1)</sup></li> <li>• Transport <sup>1)</sup></li> <li>• Operation</li> </ul>	<p>Class 1K4 acc. to EN 60721-3-1 in transport packaging. Temperature -25 °C to +55 °C. Class 2K4 acc. to EN 60721-3-2 in transport packaging. Temperature -40 °C to +70 °C. Maximum air humidity 95 % at 45 °C. Class 3K4 acc. to EN 60721-3-3. Temperature 0 °C to +40 °C. Oil mist, formation of ice, moisture condensation, water drops, water spray, water splashes and water jets are not permissible (EN 60204, Part 1).</p>
Environmental class/harmful chemical substances <ul style="list-style-type: none"> <li>• Storage</li> <li>• Transport</li> <li>• Operation</li> </ul>	<p>Class 1C2 acc. to EN 60721-3-1 in transport packaging. Class 2C2 acc. to EN 60721-3-2 in transport packaging. Class 3C2 acc. to EN 60721-3-3.</p>
Organic/biological effects <ul style="list-style-type: none"> <li>• Storage</li> <li>• Transport</li> <li>• Operation</li> </ul>	<p>Class 1B1 acc. to EN 60721-3-1 in transport packaging. Class 2B1 acc. to EN 60721-3-2 in transport packaging. Class 3B1 acc. to EN 60721-3-3.</p>
Degree of pollution	2 acc. to 60664-1.

1.7 Standards

<b>Electrical data</b>	
Installation altitude <ul style="list-style-type: none"> <li>• Blocksize format units</li> <li>• Chassis format units</li> </ul>	Up to 1000 m above sea level without de-rating. Above 1000 m with current de-rating, linear to 80 % up to 4000 m. Above 2000 m with voltage de-rating, linear to 77 % up to 4000 m. Up to 2000 m above sea level NN without de-rating, above 2000 m up to 4000 m above sea level, refer to de-rating characteristics.
<b>Certificates</b>	
Conformity	CE (low-voltage and EMC directives).
Approvals	cULus.
Certification	Safety Integrity Level 2 (SIL 2) acc. to IEC 61508, Safety Category 3 acc. to EN 954-1 for Safety Integrated – Safe Standstill (SH) and Safe Brake Control (SBC).

## 1.7 Standards

Table 1-2 Essentially the application-relevant standards

Standards	Title
EN 292-1	Safety of Machinery; General Design Guidelines; Part 1: Basic terminology, methodology
EN 292-2	Safety of Machinery; General Design Guidelines; Part 2: Technical Principles and Specifications
EN 563	Safety of machinery; temperature of services that can be touched; ergonomic data to define temperature limit values for hot surfaces
EN 755-9	Aluminum and aluminum alloys - extrusion-pressed bars, pipes and profiles - profiles, limiting dimensions and form tolerances
EN 954-1	Safety of machinery; safety-related parts of control systems; Part 1: General Design Principles
EN 1037	Safety of machinery; avoiding unexpected starting
EN 55011	Industrial, scientific and medical high-frequency devices (ISM devices) - radio interference - limit values and measuring techniques
EN 60146-1-1	Semiconductor converters; general requirements and line-commutated converters; Part 1-1: Defining the basic requirements
EN 60204-1	Electrical equipment of machines; Part 1: General definitions
IEC 60228	Conductors for cables and insulated conductors; guidelines for the limiting dimensions of round cables
EN 60269-1	Low-voltage fuses - Part 1: General requirements
IEC 60287-1 to -3	Cables - calculated the rated currents Part 1: Rated current equations (100% load factor) and calculating the losses Part 2: Thermal resistance - Part 3: Main sections for operating conditions
EN 60529	Degrees of protection provided by enclosures (IP code)

Standards	Title
EN 60664-X	Insulation coordination for equipment within low-voltage systems Part 1: Principles, requirements and tests Part 3: Use of coating, potting or moulding for protection against pollution
EN 60721-3-X	Classification of environmental conditions Part 3-0: Classification of environmental parameters and their severities; Introduction Part 3-1: Classification of environmental parameters and their severities; Long-term storage Part 3-2: Classification of environmental parameters and their severities; Transport Part 3-3: Classification of environmental parameters and their severities; stationary use, weather protected
EN 61000-6-X	Electromagnetic compatibility (EMC) Part 6-1: Generic standard; Immunity for residential, commercial and light-industrial environments Part 6-2: Generic standards; Immunity for industrial environments Part 6-3: Generic standards; Generic standard emission for residential, commercial and light-industrial environments Part 6-4: Generic standards; Generic standard noise emission for industrial environments
EN 61140	Protection against electric shock; Common aspects for installation and equipment
EN 61158	Digital data communications for measurement and control - Fieldbus for use in industrial control systems
EN 61800-2	Adjustable-speed electrical power drive systems; Part 2: General requirements - Rating specifications for low-voltage adjustable frequency a.c. power drive systems
EN 61800-3	Adjustable-speed electrical power drive systems; Part 3: EMC - Requirements and specific test methods
EN 61800-5-X	Adjustable-speed electrical power drive systems; Part 5: Safety requirements; Main section 1: Electrical, thermal and energy requirements Main section 2: Functional safety requirements
VDE 0100 Teil X (IEC 60364-X-X)	Erection of power installations with nominal voltages up to 1000 V; Part 200: Definitions Part 410: Protection for safety, protection against electric shock Part 420: Protection for safety, protection against thermal effects Part 430: Protection of cables and conductors for over-current Part 470: Protection for safety; use of protection for safety Part 450: Protection for safety, protection against undervoltage Part 5xx: Selecting and erecting electrical equipment Part 520: Wiring systems Part 540: Earthing, protective conductor, potential bonding conductor Part 560: Electrical equipment for safety purposes
ISO 9001	Quality management systems - requirements
UL 50	Enclosures for Electrical Equipment
UL 508	Industrial Control Equipment
UL 508C	Safety for Power Conversion Equipment





## Line-side power components

### 2.1 Introduction

The line connection for a SINAMICS Blocksize drive line-up comprises an optional line reactor and an optional line filter:

- Line supply voltages:
  - 1-ph. 200 V to 1-ph. 240 V AC +/- 10%.
  - 3-ph. 380 V to 3-ph. 480 V AC +/- 10%.
- Line reactor versions:
  - 3 versions for frame sizes A - C (chassis).
  - 5 versions for frame sizes D - F (3 chassis and 2 standalone).
- Line filter versions:
  - Integrated
  - External
    - chassis
    - standalone

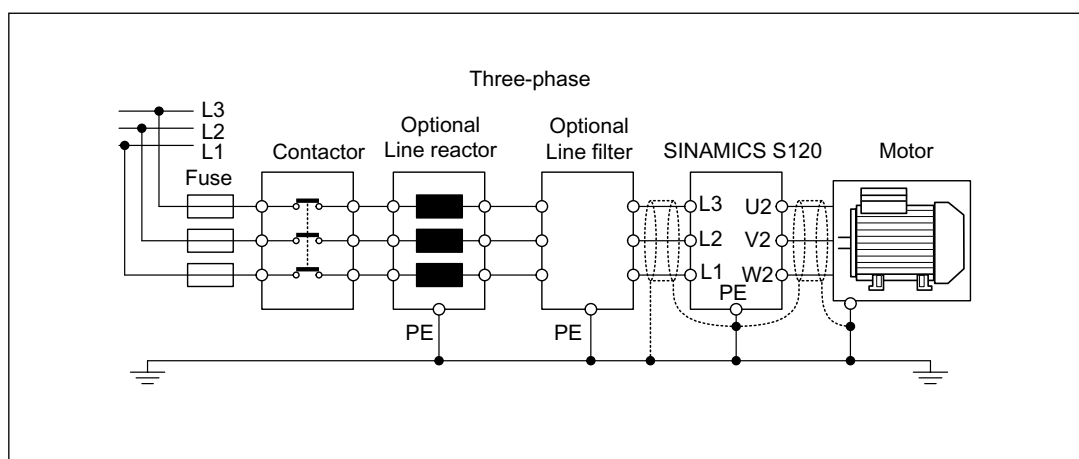

Figure 2-1 Line connection, Blocksize

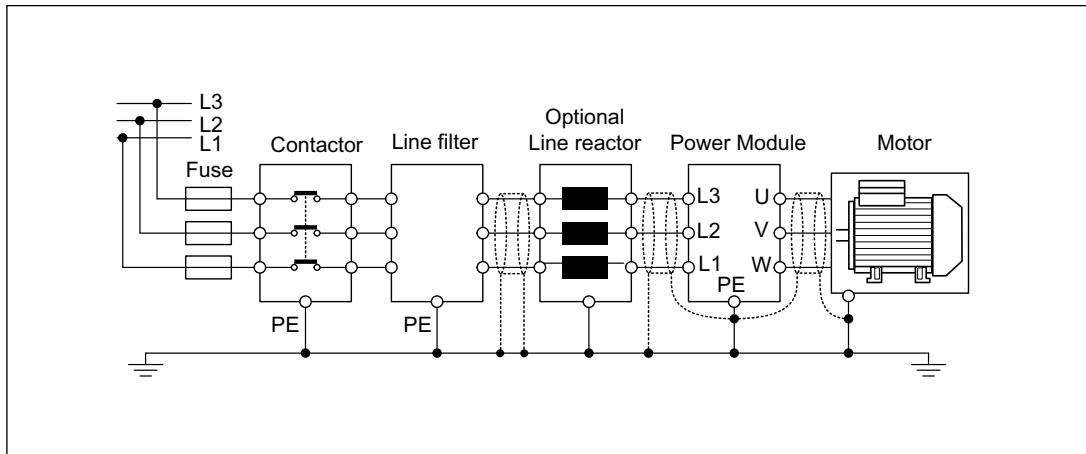

Figure 2-2 Line connection, Chassis

---

**Note**

The limit values for the radio interference voltage are only complied with when a line reactor and a line filter are used (class A1 acc. to EN 61800-5-3 C2).

---

---

**Caution**

The following can occur if line reactors/line filters are used, which have not been approved for SINAMICS by SIEMENS:

- the Power Modules could be damaged/destroyed.
  - Line reactions can occur that can damage or interfere with other loads powered from the same network.
- 

---

**Caution**

The Power Modules Blocksize with line filters are only suitable for direct connection to TN line supplies.

---

## 2.2 Line connection variants

### 2.2.1 Methods of line connection

A distinction is made between:

- Direct operation of the line connection components on the supply
- Operation of the Line Connection Components via an Autotransformer
- Operation of the Line Connection Components via an Isolating Transformer

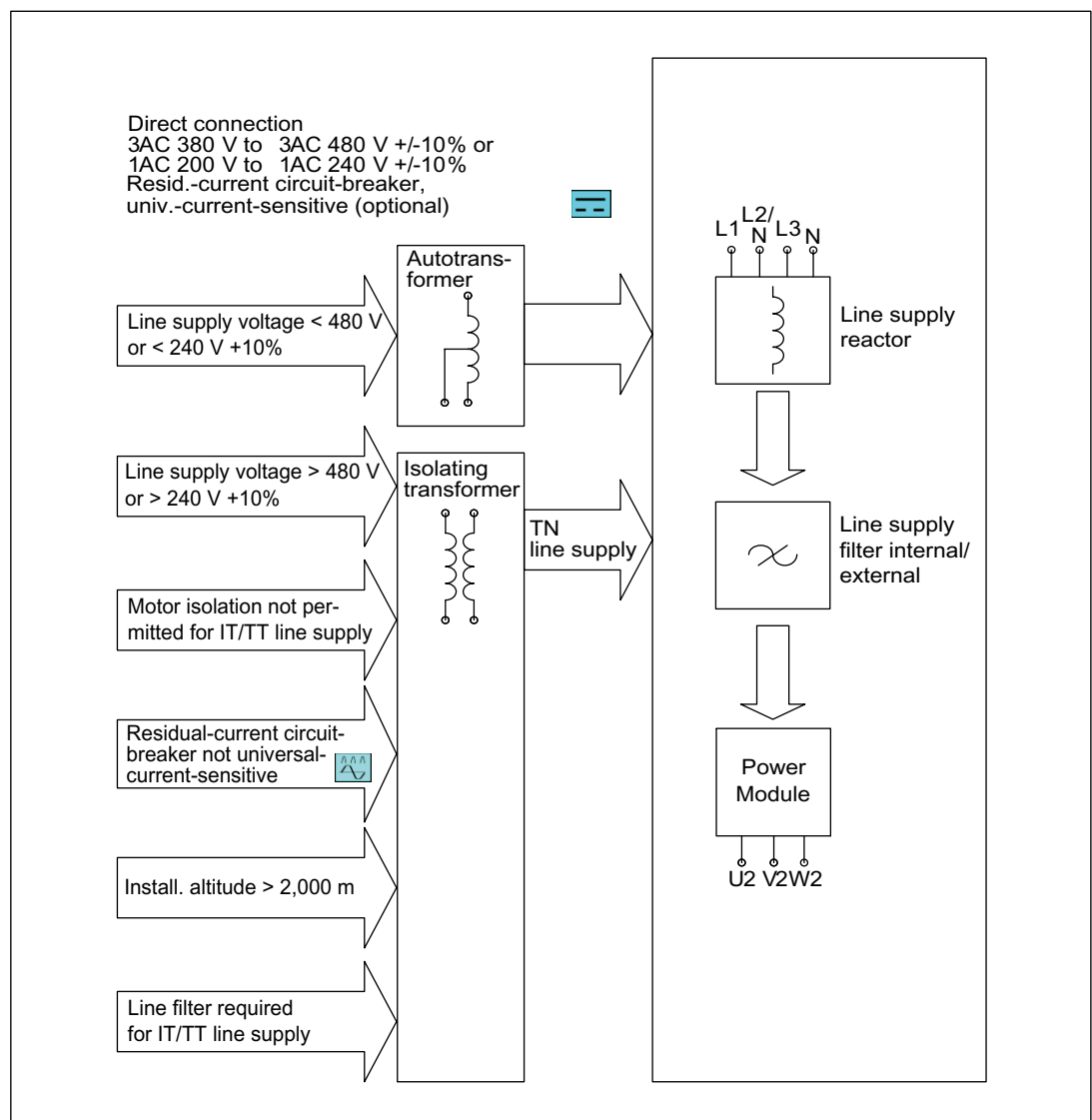

Figure 2-3 Overview of line connection variants

### 2.2.2 Operation of the Line Connection Components on the Supply Network

The SINAMICS S Blocksize drive system is designed to be directly connected to TN, TT line supply systems with grounded neutral conductor or grounded phase conductor as well as to IT line systems with rated voltages from 3-ph. 380 V to 480 V AC and 1-ph. 200 V to 240 V AC. Operation with line filter is only possible, without having to use additional measures, when connected to TN line supply systems with grounded neutral conductor.

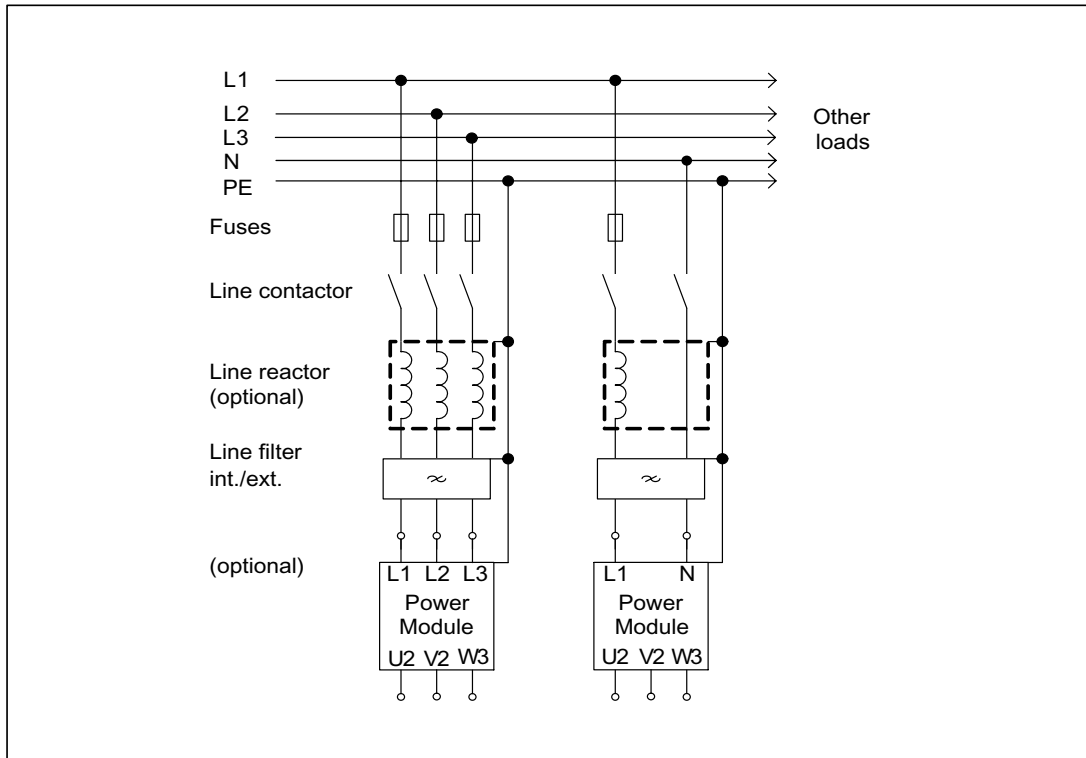

Figure 2-4 Direct operation on the line supply

### 2.2.3 Operation of the Line Connection Components via an Autotransformer

An autotransformer can be used for voltage adaptation in the range up to 3-ph. 480 V AC +10% or 1-ph. 240 V AC +10%.



#### Caution

To ensure protective separation, an isolating transformer must be used for voltages greater than 3-ph. 480 V AC +10% and 1-ph. 240 V AC +10%.

Application example:

- The motor insulation must be protected from excessive voltages.

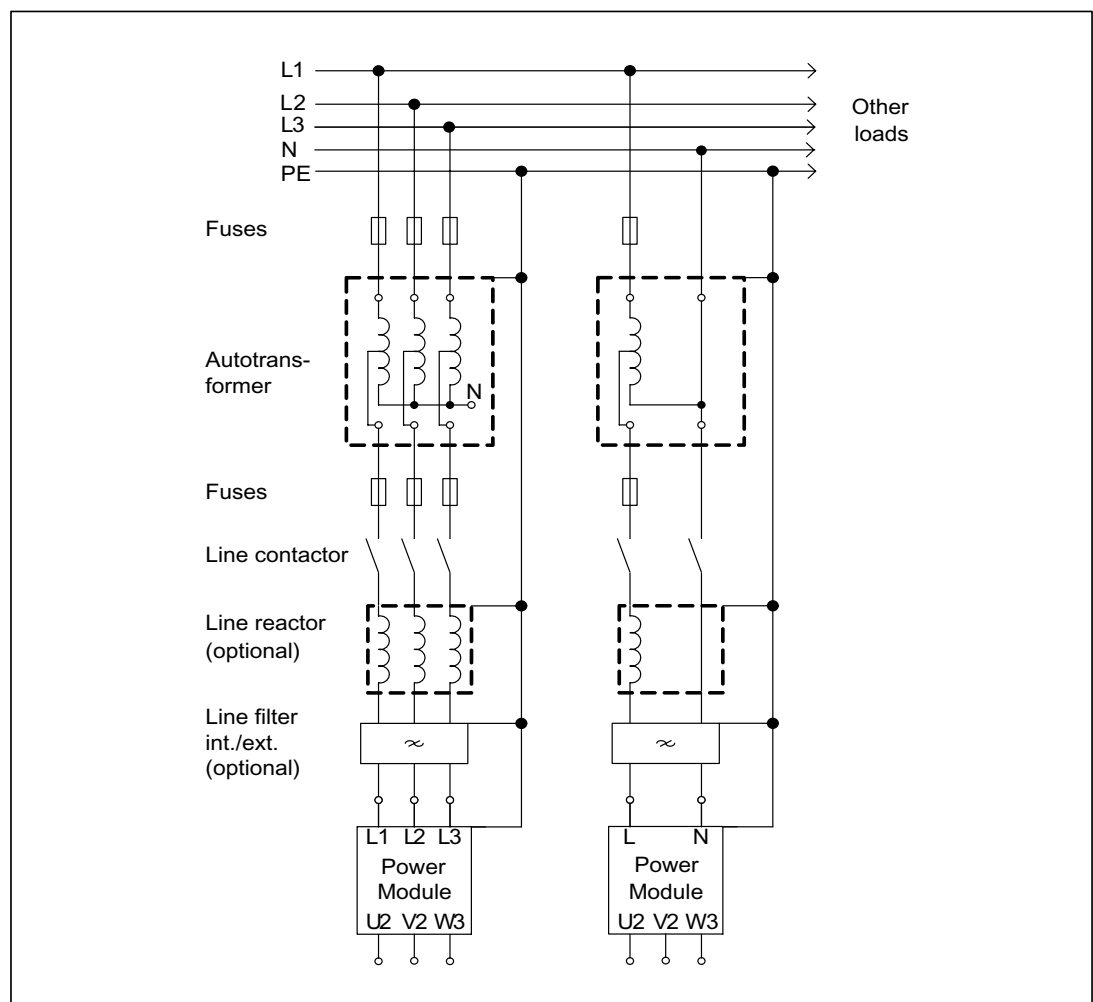

Figure 2-5 Autotransformer

## **2.2.4 Operation of the Line Connection Components via an Isolating Transformer**

The isolating transformer converts the type of the line supply type in the plant (e.g. IT/TT line supply) to a TN line supply. Additional voltage adaptation to the permissible voltage tolerance range is possible.

An isolating transformer must be used in the following cases:

- The insulation of the Power Module and/or the motor is not adequate for the voltages that occur.
- There is no compatibility to an existing residual-current protective device.
- The installation altitude is greater than 2000 m above sea level.
- For all other systems that are not TN line supply systems with grounded neutral conductor, a line filter should always be used.

---

### **Caution**

If the line supply voltage is greater than 3-ph. 480 V AC +10% or 1-ph. 240 V AC +10%, it is not permissible that an autotransformer is used.

In order to ensure protective separation, an isolating transformer must always be used.

---

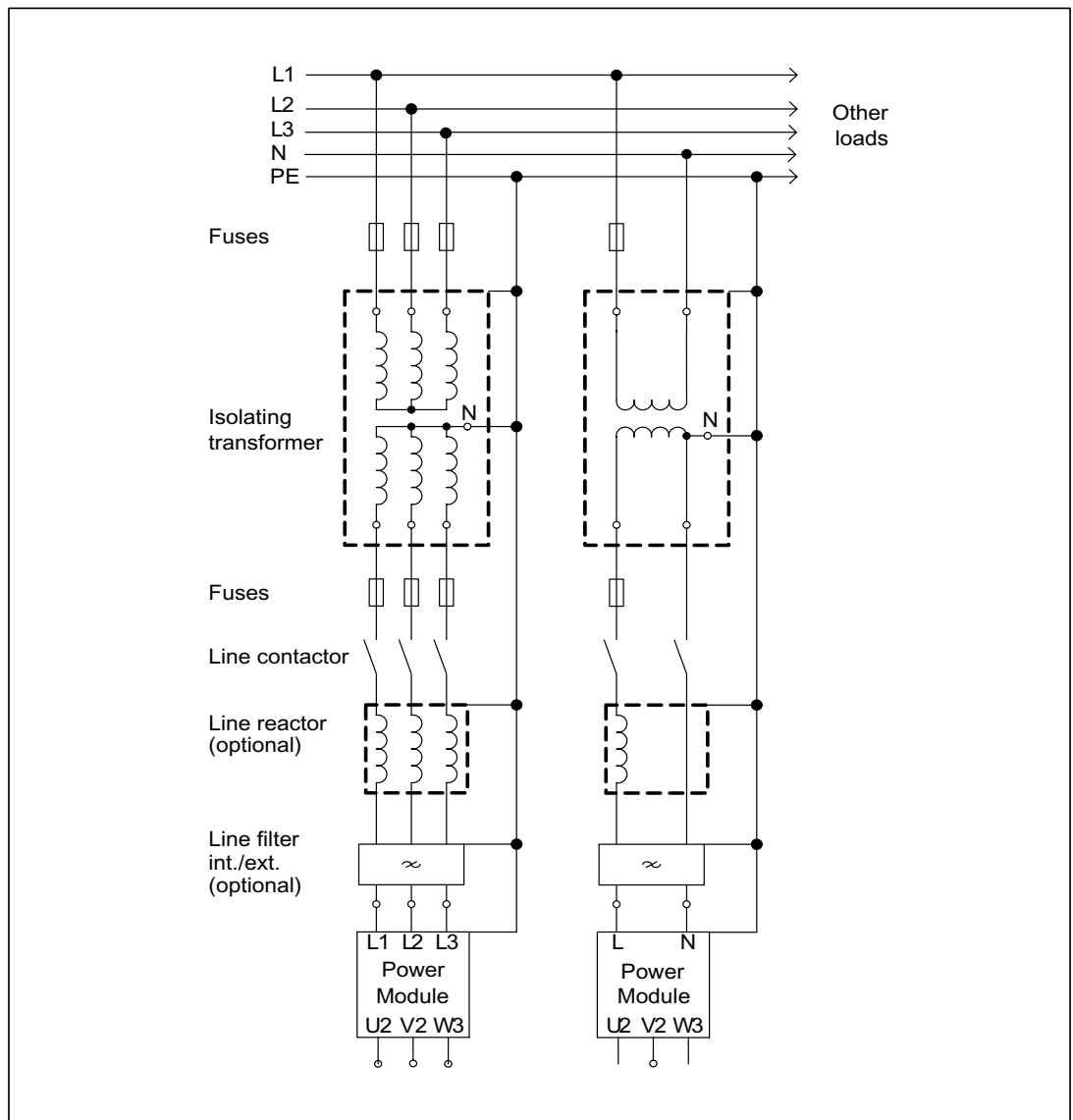

Figure 2-6 Isolating transformer

## 2.2.5 Line Connection via a Residual-Current Circuit-Breaker

In preparation

## 2.3 Line filter

### 2.3.1 Description

In conjunction with line reactors and a consequential implementation of the plant/system configuration according to the EMC guidelines (Order No.: 6FC5297-□AD30-0AP□), line filters limit the cable-borne noise and disturbances emitted from power modules to permissible values for the industrial environment at the installation location.

---

#### Note

All PM340 Power Modules are equipped with an integrated line filter.  
Frame size A, 400V, is an exception; in this case, an external line filter must be used.

---

### 2.3.2 Safety information



---

#### Danger

Line filters are suitable for direct connection to TN line supplies with grounded neutral conductor.

---



---

#### Caution

The cooling clearances of 100 mm above and below the components must be observed. This prevents thermal overload of the line filter.

---



---

#### Caution

The terminals must be correctly connected:

- Incoming line cable to LINE/NETZ L1, L2, L3
- Outgoing cable to the line reactor to LOAD/LAST L1', L2', L3'

Non-observance may damage the line filter

---



---

#### Caution

Using line filters not released by Siemens AG for SINAMICS can lead to line reactions that can damage or destroy other loads powered from the network.

---



### 2.3.3 Dimension drawing, Blocksize

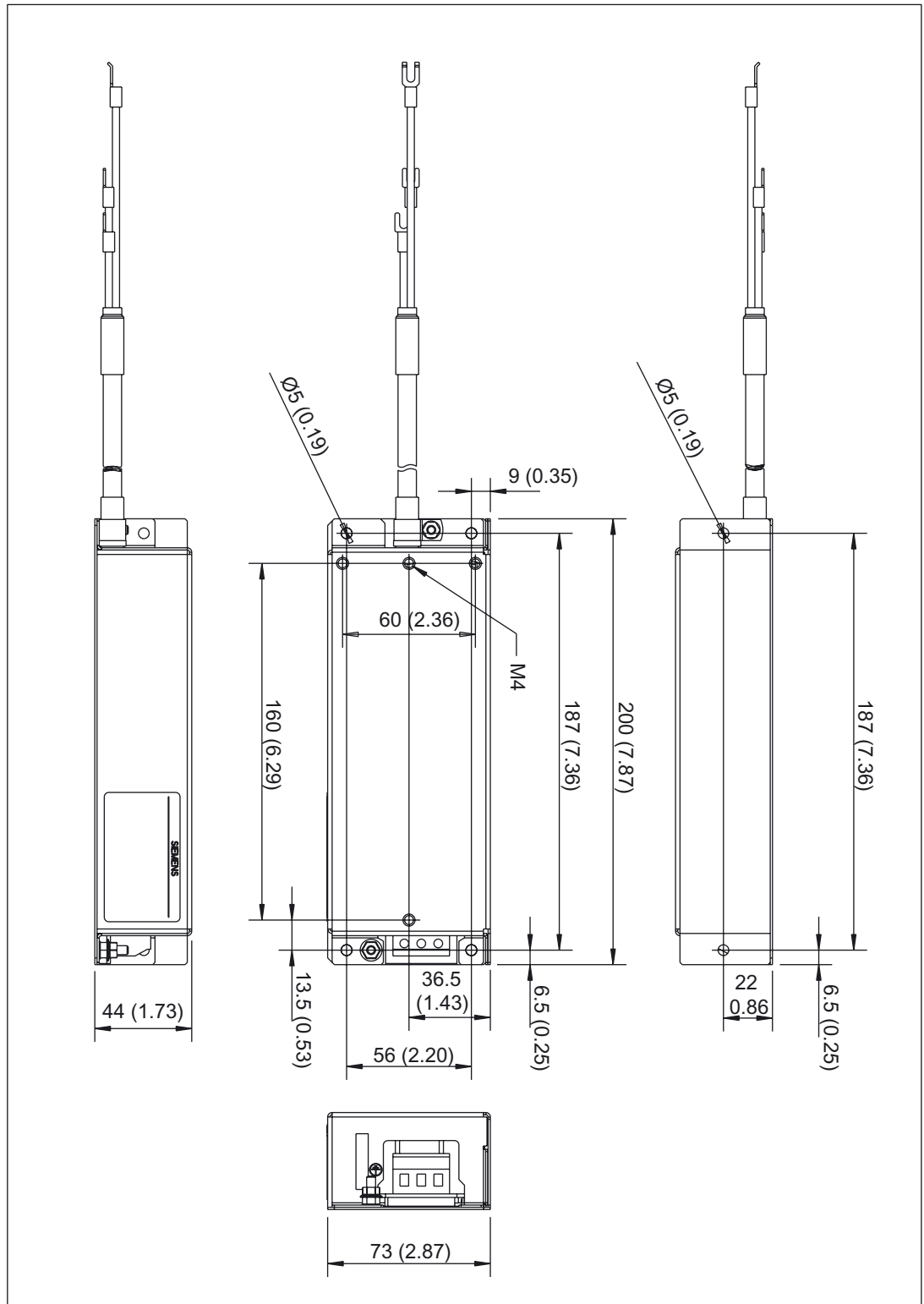

Figure 2-7 Dimension drawing: Line filter, frame size A

2.3.4 Dimension drawing, Chassis

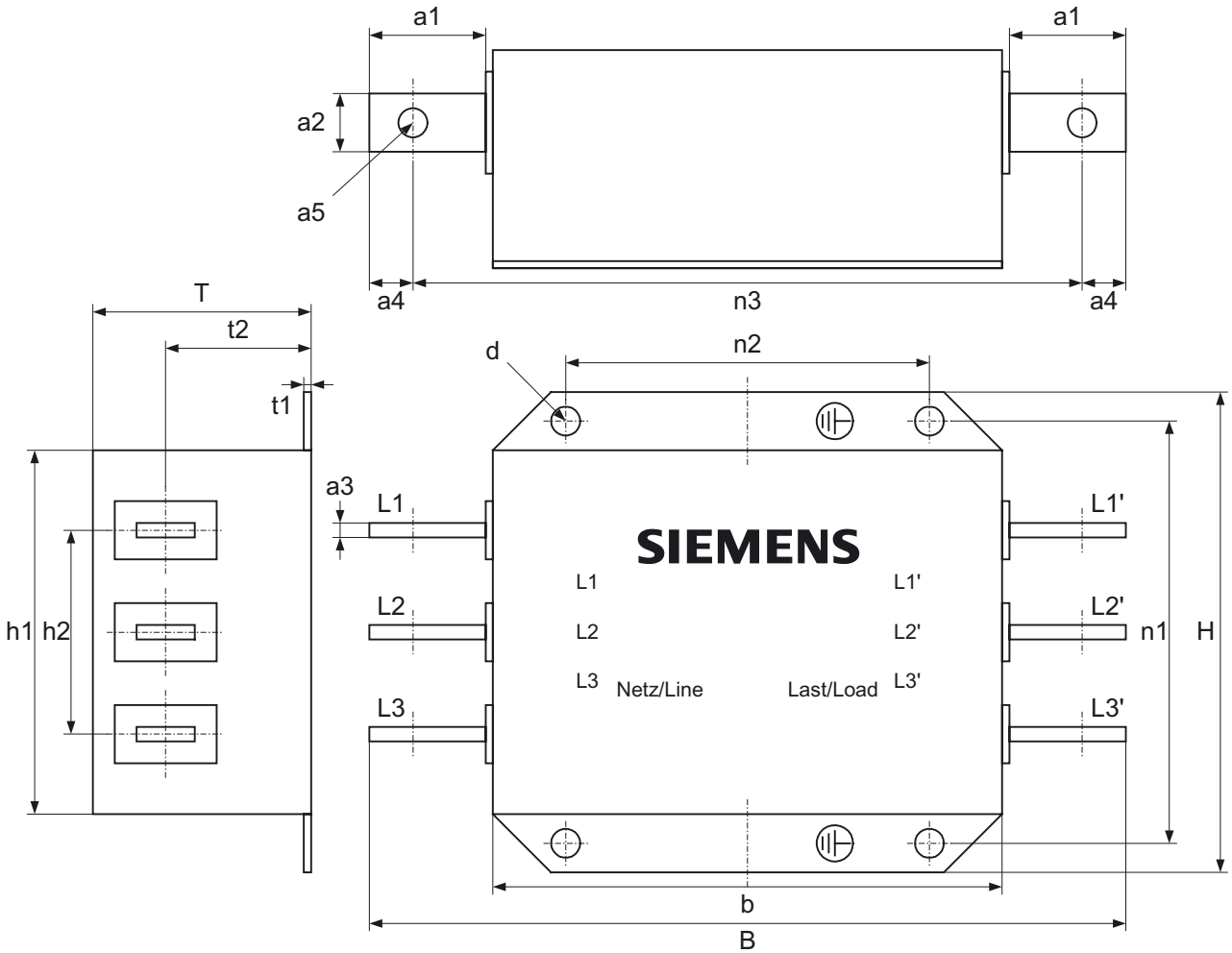

Figure 2-8 Dimension drawing, line filter

Table 2-1 Dimensions of the line filter, all data in mm and (inches)

6SL3000-	OBE32-5AA0	OBE34-4AA0	OBE36-0AA0
B	330 (12.99)	360 (14.17)	400 (15.74)
H	240 (9.44)	240 (9.44)	265 (10.43)
T	116 (4.56)	116 (4.56)	140 (5.51)
a1	40 (1.57)	40 (1.57)	40 (1.57)
a2	25 (0.98)	25 (0.98)	25 (0.98)
a3	5 (0.19)	5 (0.19)	8 (0.31)
a4	15 (0.59)	15 (0.59)	15 (0.59)
a5	11 (0.43)	11 (0.43)	11 (0.43)
b	270 (10.62)	270 (10.62)	310 (12.20)
h1	200 (7.87)	200 (7.87)	215 (8.46)
h2	100 (3.93)	100 (3.93)	120 (4.72)

6SL3000-	0BE32-5AA0	0BE34-4AA0	0BE36-0AA0
t1	2 (0.07)	2 (0.07)	2.5 (0.09)
t2	78.2 (3.07)	78.2 (3.07)	90 (3.54)
n1 <sup>1)</sup>	220 (8.66)	220 (8.66)	240 (9.44)
n2 <sup>1)</sup>	210 (8.26)	210 (8.26)	250 (9.84)
n3	330 (12.99)	330 (12.99)	370 (14.56)
d	9 (0.35)	9 (0.35)	12 (0.47)

1) Lengths n1 and n2 correspond to the distance between holes

### 2.3.5 Installation

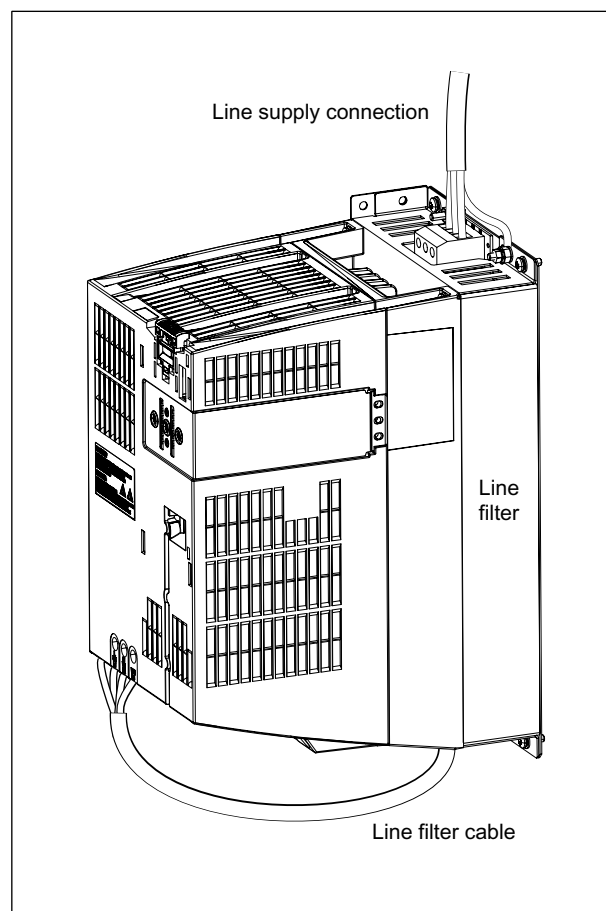

Figure 2-9 Mounting: Power Module with line filter

2.3 Line filter

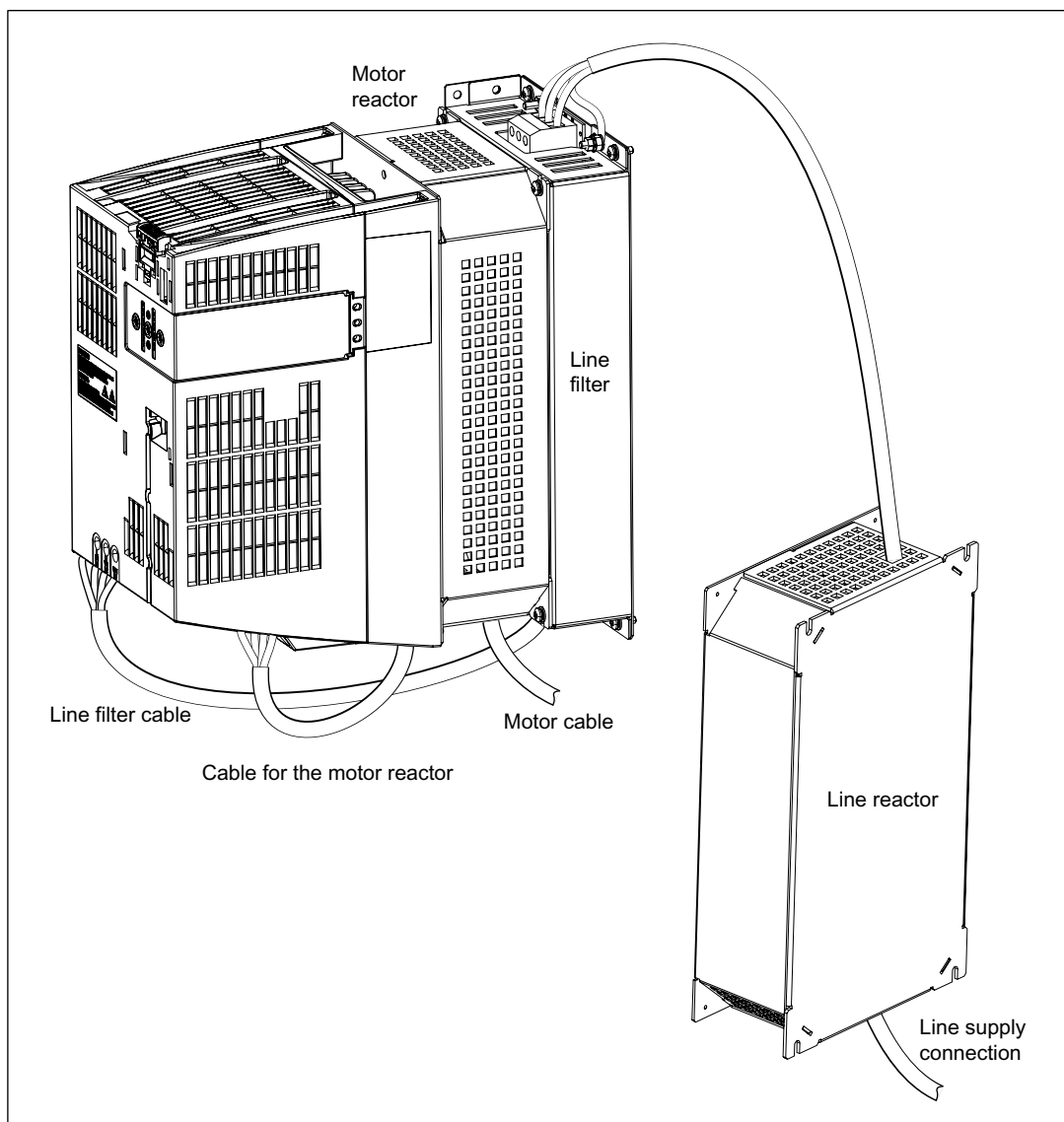

Figure 2-10 Mounting: Power Module with motor reactor, line filter and line reactor

### 2.3.6 Electrical Connection

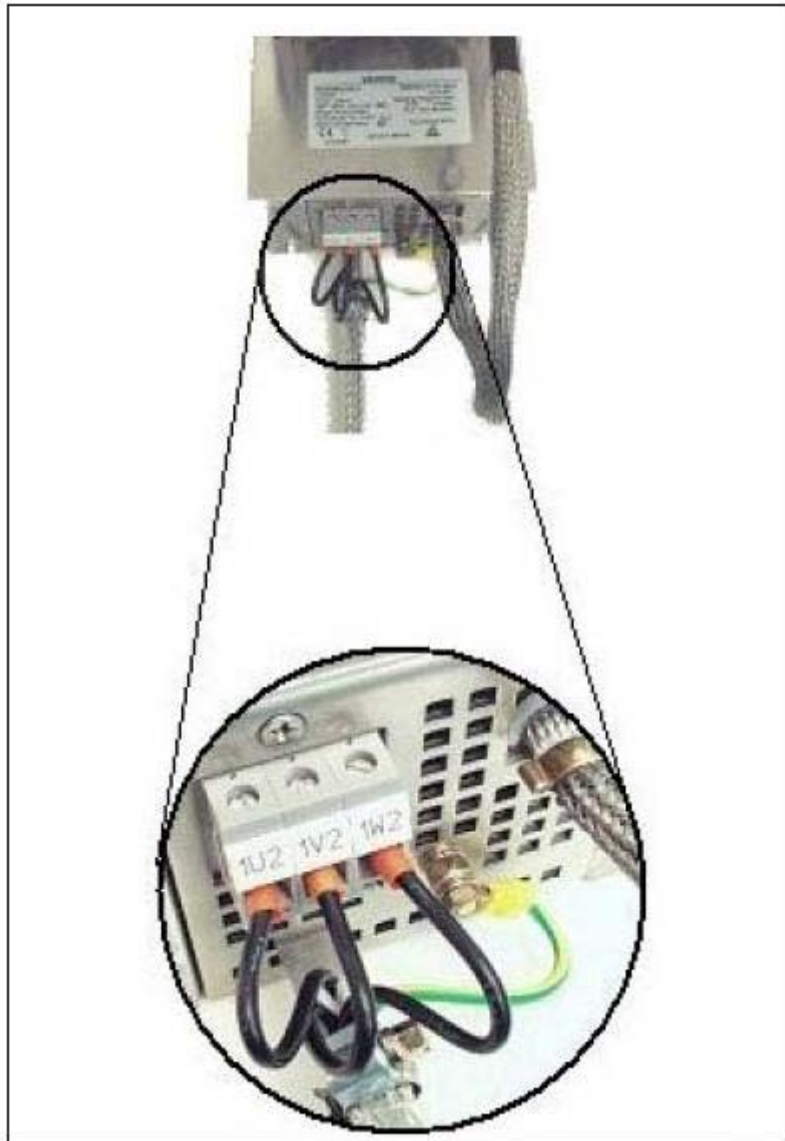

Figure 2-11 Shielding: Line filter, frame size A

2.3 Line filter

2.3.7 Technical data, Blocksize line filter

Table 2-2 Technical data, Blocksize line filter

Line supply voltage 3-ph. 380...480 V AC		
Line filter 6SE6400-2FA00-6AD0		
Suitable for Power Module		6SL3210-1SE11-3UA0, 6SL3210-1SE11-7UA0 6SL3210-1SE12-2UA0, 6SL3210-1SE13-1UA0 6SL3210-1SE14-1UA0
Rated current	A	6
Power loss	W	< 5
Line supply connection L1, L2, L3		2.5 mm screw terminals <sup>2</sup>
PE connection		At the housing with M4 stud
Load connection U, V, W		Shielded cable 3 x 2.5 mm <sup>2</sup> 0.4 m long
Degree of protection		IP20 or IPXXB
Weight, approx.	kg	0.5

2.3.8 Technical data, Chassis line filter

Table 2-3 Technical data, Chassis line filter

Order No.	6SL3000-	0BE32-5AA0	0BE34-4AA0	0BE34-4AA0	0BE34-4AA0	0BE36-0AA0
Suitable for Power Module	6SL3310-	1TE32-1AA0	1TE32-6AA0	1TE33-1AA0	1TE33-8AA0	1TE35-0AA0
Rated power of the Power Module	kW	110	132	160	200	250
Rated voltage	V	3-ph. 380 V AC -10 % to 3-ph. 480 V AC +10 % (-15 % < 1 min), 47 to 63 Hz				
Rated current	A	250	440	440	440	600
Power loss	kW		0.049	0.049	0.049	0.055
Line supply/load connection L1, L2, L3 / L1', L2', L3'		M10	M10	M10	M10	M10
Dimensions						
Width	mm	360	360	360	360	400
Height	mm	240	240	240	240	265
Depth	mm	116	116	116	116	140
Weight	kg	12.3	12.3	12.3	12.3	19.0

## 2.4 Line reactors

### 2.4.1 Description

The line reactors limit lower-frequency harmonics that are fed back into the line supply. They are used to smooth voltage spikes (line supply faults) or to bridge voltage dips/interruptions when commutating. This is the reason that we recommend line reactors in conjunction with PM340 and Power Module Chassis.

### 2.4.2 Safety information



---

**Caution**

The cooling clearances of 100 mm above and below the components must be observed.

---

**Note**

The connecting cables to the Power Module must be as short as possible (max. 5 m). If possible, they should be shielded.

---

**Caution**

The terminals must be correctly connected:

- Incoming line cable to 1U1, 1V1, 1W1, and
- Outgoing cable to the load 1U2, 1V2, 1W2.

Non-observance may damage the line reactor.

---

**Caution**

When using line reactors that have not been approved by SIEMENS for SINAMICS, the following can occur:

- the Power Modules could be damaged/destroyed.
  - Line harmonics that may interfere with or damage other loads connected to the same line supply.
- 

**Caution**

The surface temperature of the line reactors may exceed 80 °C.

---

2.4.3 Dimension drawings, Blocksize line reactors

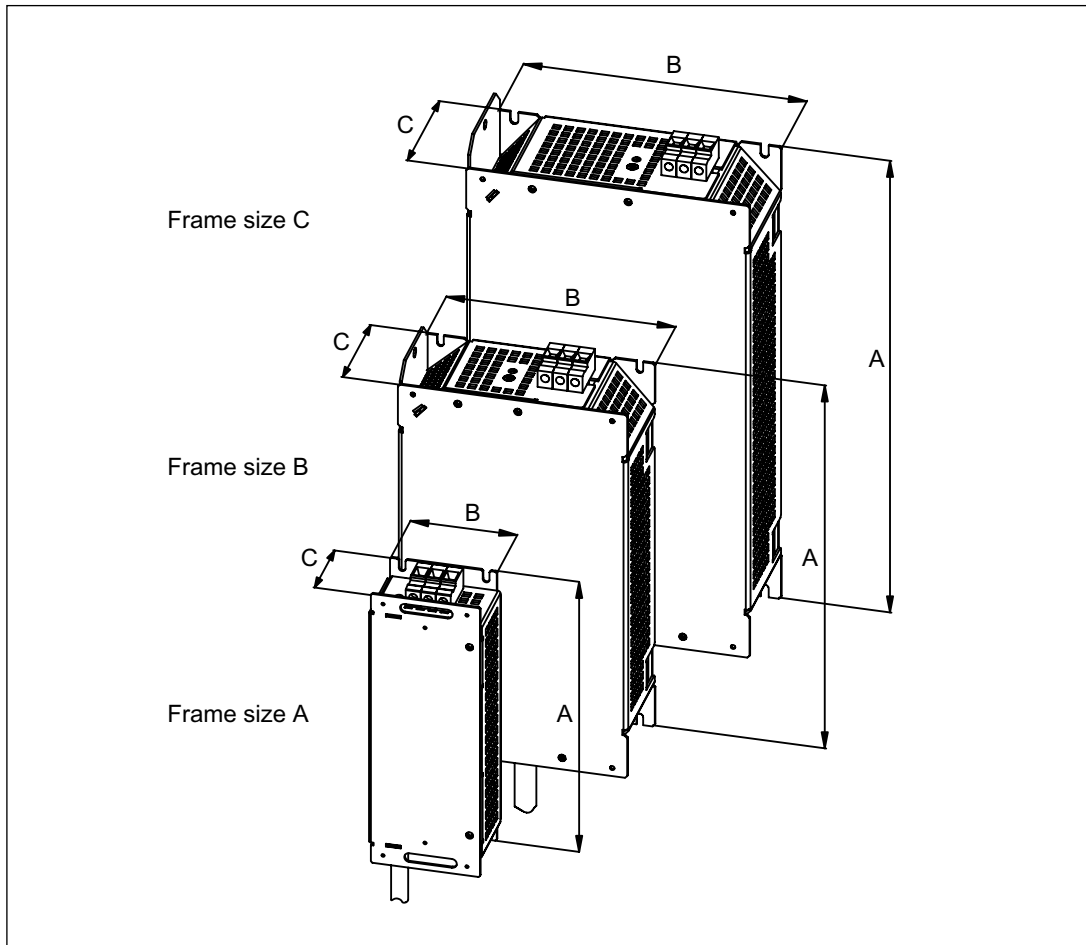

Figure 2-12 Dimension drawing: Line reactor, frame sizes A, B and C

Table 2-4 Total and retaining dimensions, line reactors, Part 1

Line reactor 6SE6400-	3CC00-4AB3	3CC01-0AB3	3CC00-2AD3	3CC00-2AD3	3CC00-4AD3
Suitable for Power Module 6SL3210-	1SB11-0UA0	1SB14-0UA0	1SE11-3UA0	1SE11-7UA0	1SE12-2UA0
Frame size	A				
Dimension A in mm and (inches)	200 (7.87)				
Dimension B in mm and (inches)	75 (2.95)				
Dimension C in mm and (inches)	50 (1.96)				



Table 2-5 Total and retaining dimensions, line reactors, Part 2

Line reactor	6SE6400-3CC00-4AD3	6SE6400-3CC00-6AD3	6SL3203-0CD21-0AA0	6SL3203-0CD21-0AA0	6SL3203-0CD21-4AA0
Suitable for Power Module 6SL3210-	1SE13-1UA0	1SE14-1UA0	1SE16-0UA0	1SE17-7UA0	1SE21-0UA0
Frame size	A		B		
Dimension A in mm and (inches)	200 (7.87)		270 (10, 62)		
Dimension B in mm and (inches)	75 (2.95)		153 (6.02)		
Dimension C in mm and (inches)	50 (1.96)		70 (2.75)		

Table 2-6 Total and retaining dimensions, line reactors, Part 3

Line reactor 6SL3203-	0CD22-2AA0	0CD22-2AA0	0CD23-5AA0
Suitable for Power Module 6SL3210-	1SE21-8UA0	1SE22-5UA0	1SE23-2UA0
Frame size	C		
Dimension A in mm and (inches)	336 (13.22)		336 (13.22)
Dimension B in mm and (inches)	189 (7.44)		189 (7.44)
Dimension C in mm and (inches)	50 (1.96)		80 (3.14)

2.4 Line reactors

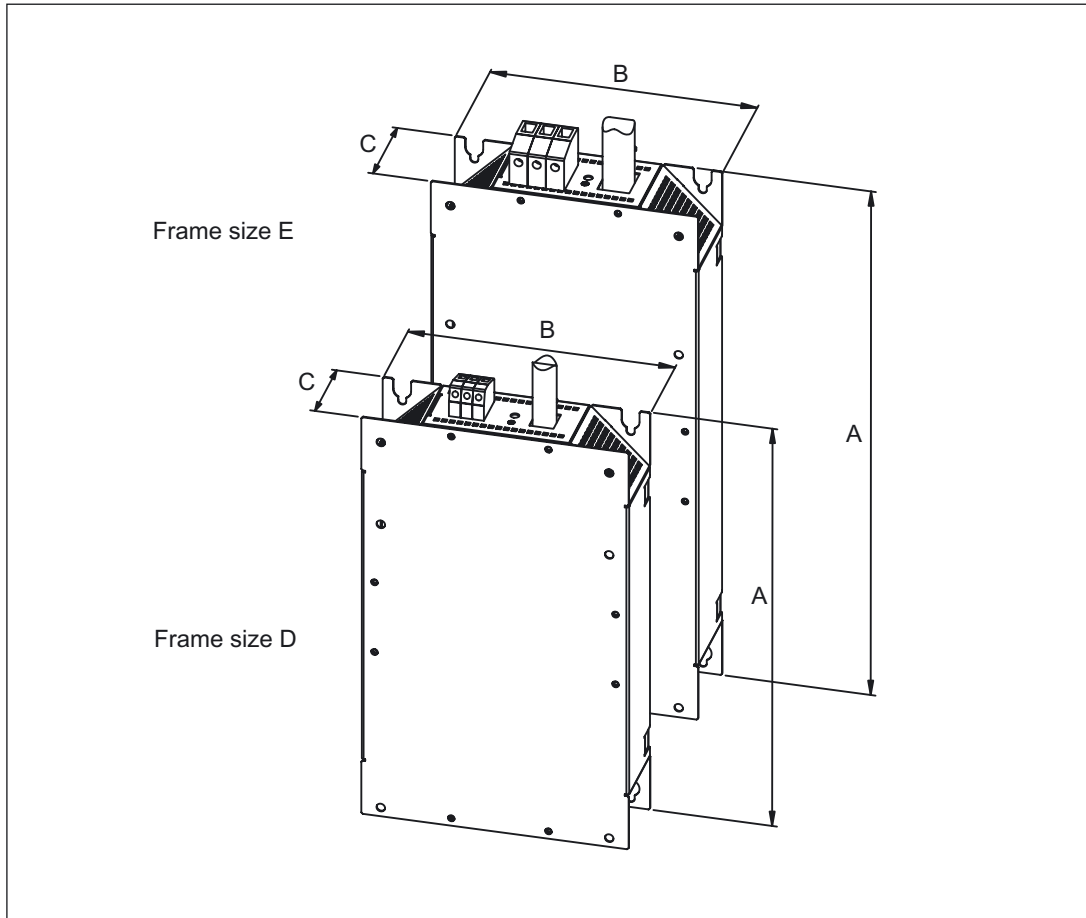

Figure 2-13 Dimension drawing: Line reactor frame sizes D and E

Table 2-7 Total and retaining dimensions, line reactor

Line reactor 6SL3203-	0CJ24-5AA0	0CJ24-5AA0	0CD25-3AA0	0CJ28-6AA0	0CJ28-6AA0
Suitable for Power Module 6SL3210-	1SE23-8UA0	1SE24-5UA0	1SE26-0UA0	1SE27-5UA0	1SE31-0UA0
Frame size	D			E	
Dimension A in mm and (inches)	455 (17.91)			577 (22.71)	
Dimension B in mm and (inches)	275 (10.82)			275 (10.82)	
Dimension C in mm and (inches)	83.5 (3.28)			93.5 (3.68)	

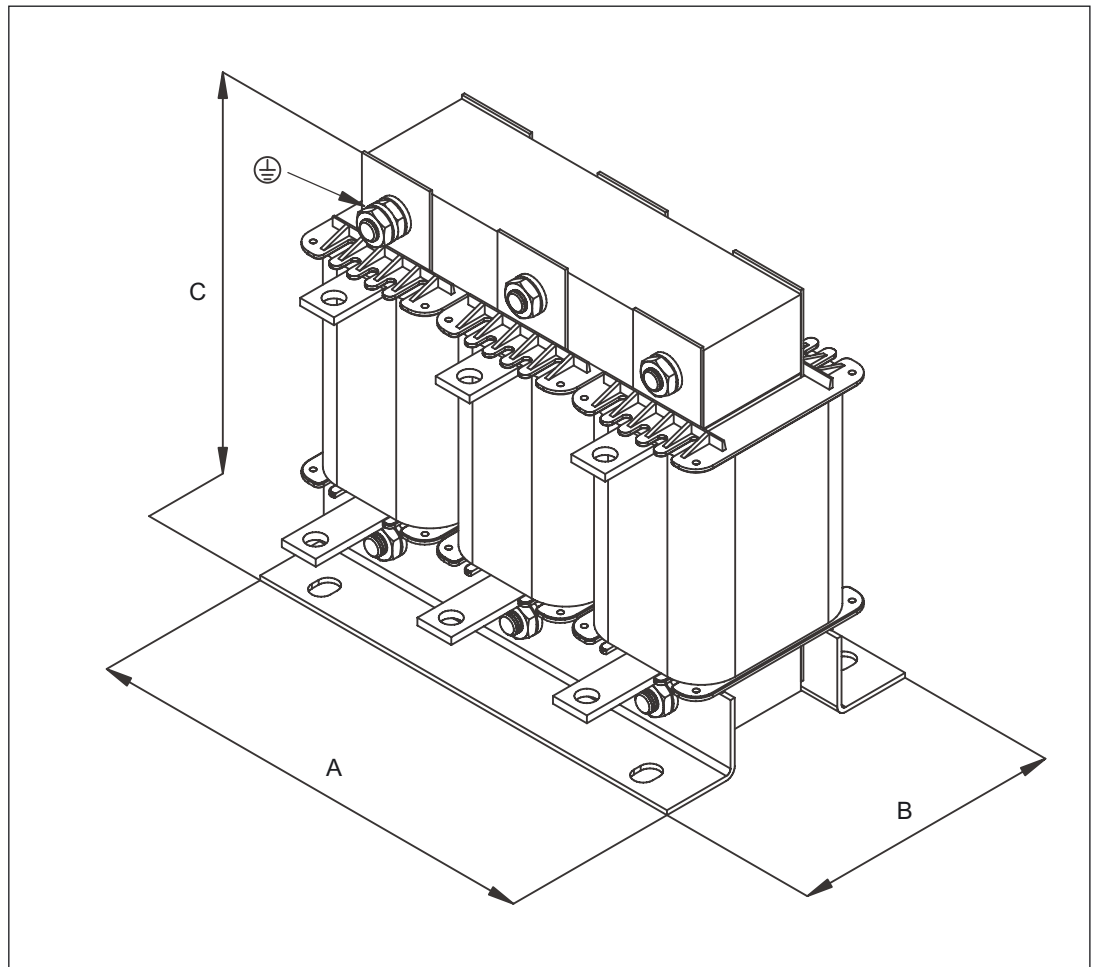

Figure 2-14 Dimension drawing: Line reactor, frame size F

Table 2-8 Total and retaining dimensions, line reactor

Line reactor 6SE6400- Suitable for Power Module 6SL3210- Frame size	3CC11-2FD0 1SE31-1UA0	3CC11-2FD0 1SE31-5UA0	3CC11-7FD0 1SE31-8UA0
Dimension A in mm and (inches)	240 (9.44)		
Dimension B in mm and (inches)	141 (5.55)		
Dimension C in mm and (inches)	228 (8.97)		

### 2.4.4 Dimension drawing, Chassis line reactor

#### Dimension drawing of the line reactors

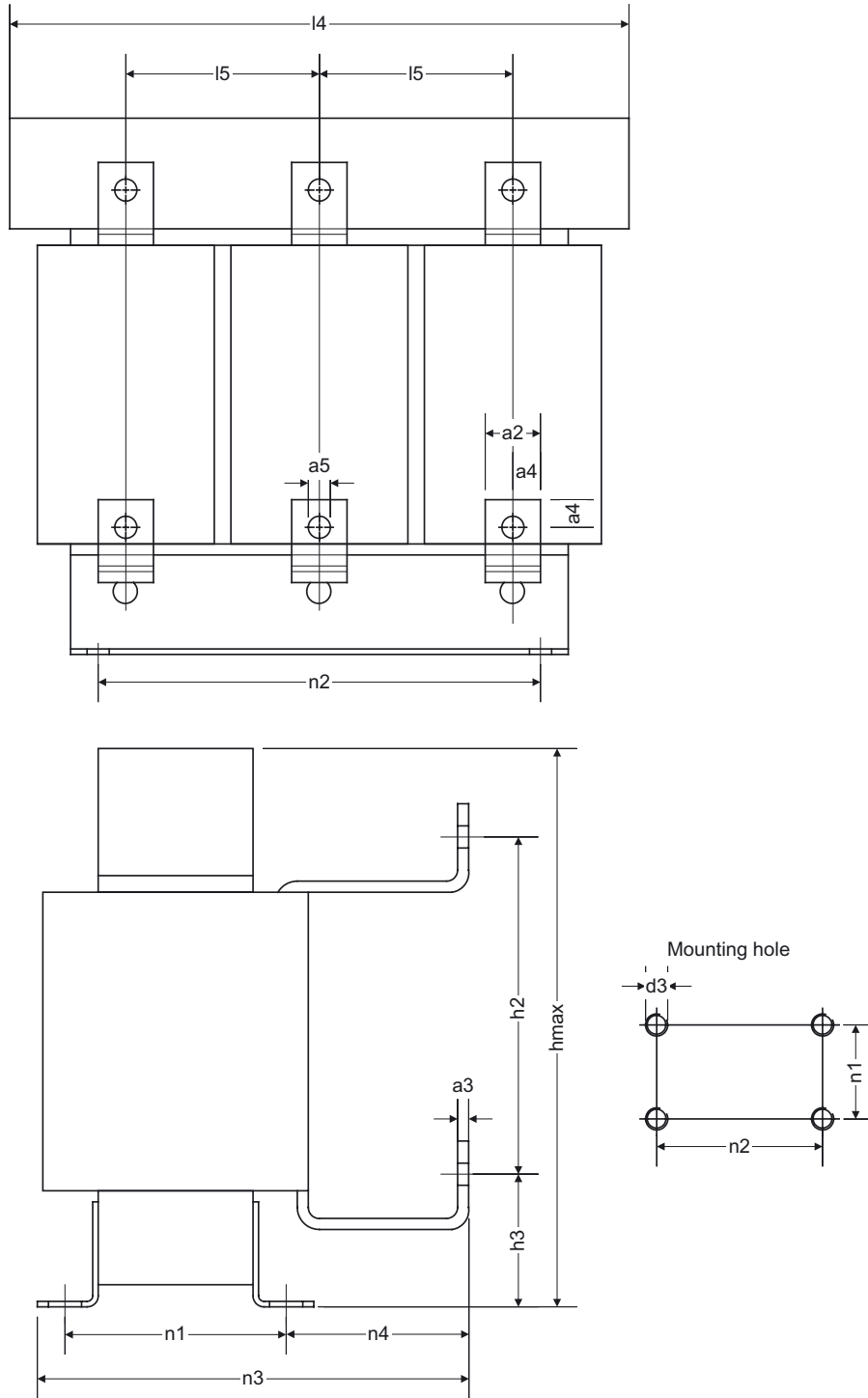

Figure 2-15 Dimension drawing, line reactors

Table 2-9 Dimensions of the line reactors, all data in mm and (inches)

6SL3000-	0CE32-3AA0	0CE32-8AA0	0CE33-3AA0	0CE35-1AA0
a2	25 (0.98)	25 (0.98)	25 (0.98)	30 (1.18)
a3	5 (0.19)	5 (0.19)	5 (0.19)	6 (0.23)
a4	12.5 (0.49)	12.5 (0.49)	12.5 (0.49)	15 (0.59)
a5	11 (0.43)	11 (0.43)	11 (0.43)	14 (0.55)
l4	270 (10.62)	270 (10.62)	270 (10.62)	300 (11.81)
l5	88 (3.46)	88 (3.46)	88 (3.46)	100 (3.93)
hmax	248 (9.76)	248 (9.76)	248 (9.76)	269 (10.59)
h2	150 (5.90)	150 (5.90)	150 (5.90)	180 (7.08)
h3	60 (2.36)	60 (2.36)	60 (2.36)	60 (2.36)
n1 <sup>1)</sup>	101 (3.97)	101 (3.97)	101 (3.97)	118 (4.64)
n2 <sup>1)</sup>	200 (7.87)	200 (7.87)	200 (7.87)	224 (8.81)
n3	200 (7.87)	200 (7.87)	200 (7.87)	212.5 (8.36)
n3	84.5 (3.32)	84.5 (3.32)	84.5 (3.32)	81 (3.19)
d3	M8	M8	M8	M8

1) Lengths n1 and n2 correspond to the distance between holes

2.4.5 Installation

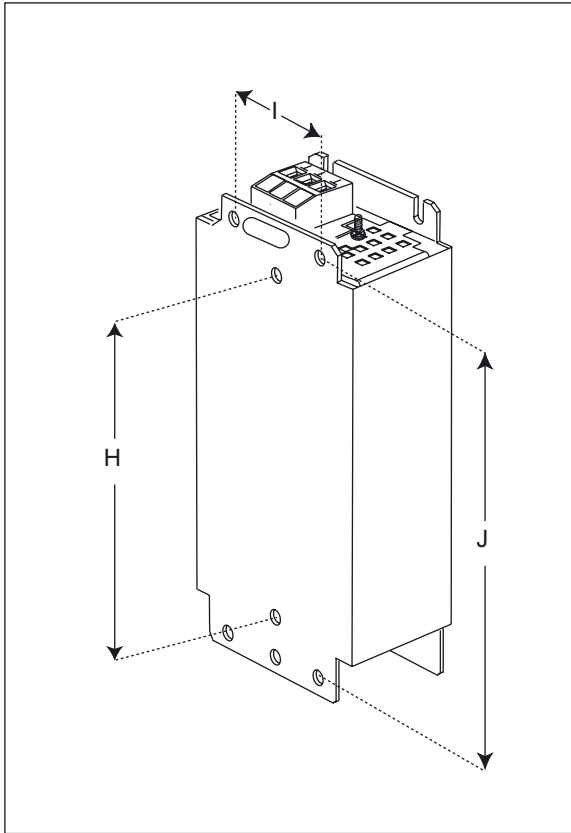

Figure 2-16 Mounting: Line reactor, frame size A

Table 2-10 Total and retaining dimensions, line reactor, Part 1, all data in mm and (inches)

Line reactor 6SE6400-	3CC00-4AB3	3CC01-0AB3	3CC00-2AD3	3CC00-4AD3	3CC00-6AD3
Suitable for Power Module 6SL3210-	1SB11-0UA0 1SB11-0AA0 1SB12-3UA0 1SB12-3AA0	1SB14-0UA0 1SB14-0AA0	1SE11-3UA0 1SE11-7UA0	1SE12-2UA0 1SE13-1UA0	1SE14-1UA0
Frame size	A				
H	160 (6.29)				
I	56 (2.20)				
J	187 (7.36)				
	Retaining screw M4 / 1.1 Nm Cable cross-section: 1.0 - 2 mm <sup>2</sup> .				

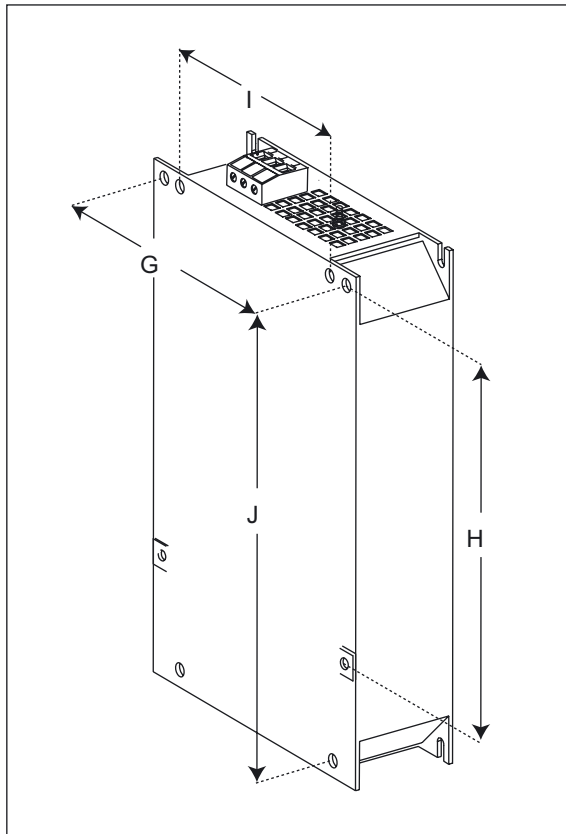

Figure 2-17 Mounting: Line reactors, frame sizes B and C

Table 2-11 Total and retaining dimensions, line reactor, Part 2, all data in mm and (inches)

Line reactor	0CD21-0AA0	0CD21-4AA0	0CD22-2AA0	0CD22-2AA0	0CD23-5AA0
6SL3203-					
Suitable for Power Module	1SE16-0UA0	1SE21-0UA0	1SE21-8UA0	1SE21-8UA0	1SE23-2UA0
6SL3210-	1SE16-0AA0	1SE21-0AA0	1SE21-8AA0	1SE21-8AA0	1SE23-2AA0
	1SE17-7UA0		1SE22-5UA0	1SE22-5UA0	
	1SE17-7AA0		1SE22-5AA0	1SE22-5AA0	
Frame size	B			C	
G	138 (5.43)			174 (6.85)	
H	174 (6.85)			204 (8.03)	
I	120 (4.72)			156 (6.14)	
J	200 (7.87)			232 (9.13)	
	Retaining screw M4 / 1.5 Nm Cable cross-section: 1.5 - 6 mm <sup>2</sup> ).			Retaining screw M5 / 2.25 Nm Cable cross-section: 2.5 - 10 mm <sup>2</sup> ).	

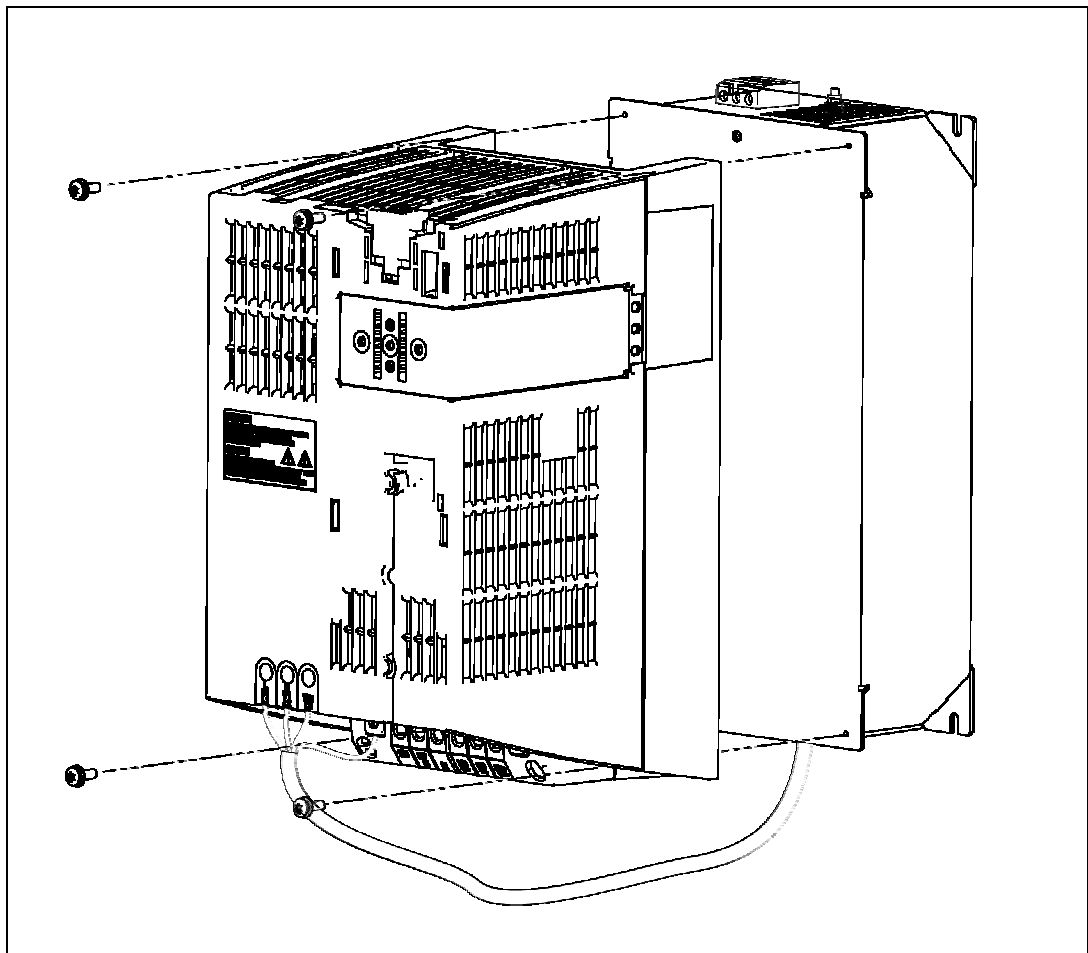

Figure 2-18 Mounting: PM340 and line reactor, frame size B



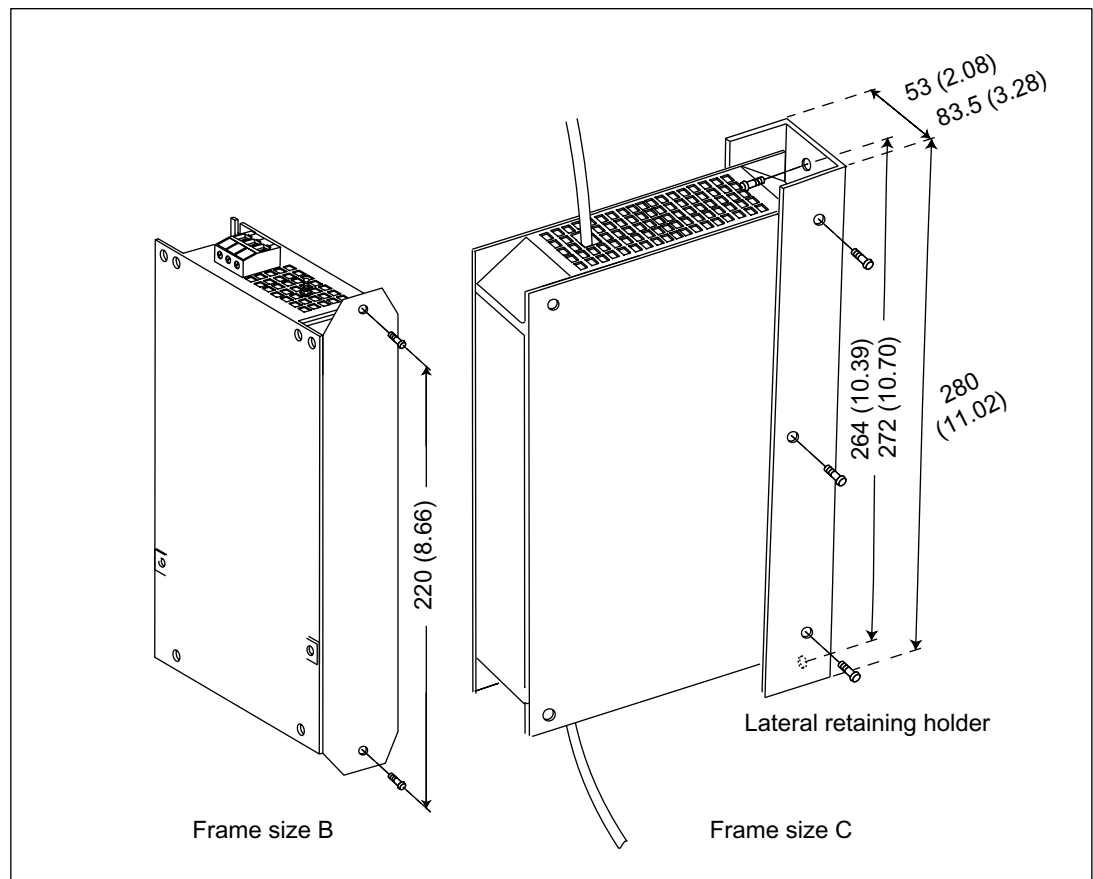

Figure 2-19 Side mounting: Line reactors, frame sizes B and C

The line reactors for Power Modules, frame sizes A - E, are designed as sub-chassis components.

The line reactor is retained on the mounting surface and the Power Module is mounted on the line reactor in a space-saving fashion. The cables to the Power Modules are already connected at the line reactor.

The line reactor is connected to the line supply through terminals.

The reactors for Power Modules, frame sizes F, FX and GX are, as a result of their weight and their size, separately mounted.

### 2.4.6 Electrical Connection

#### Line supply/load connection

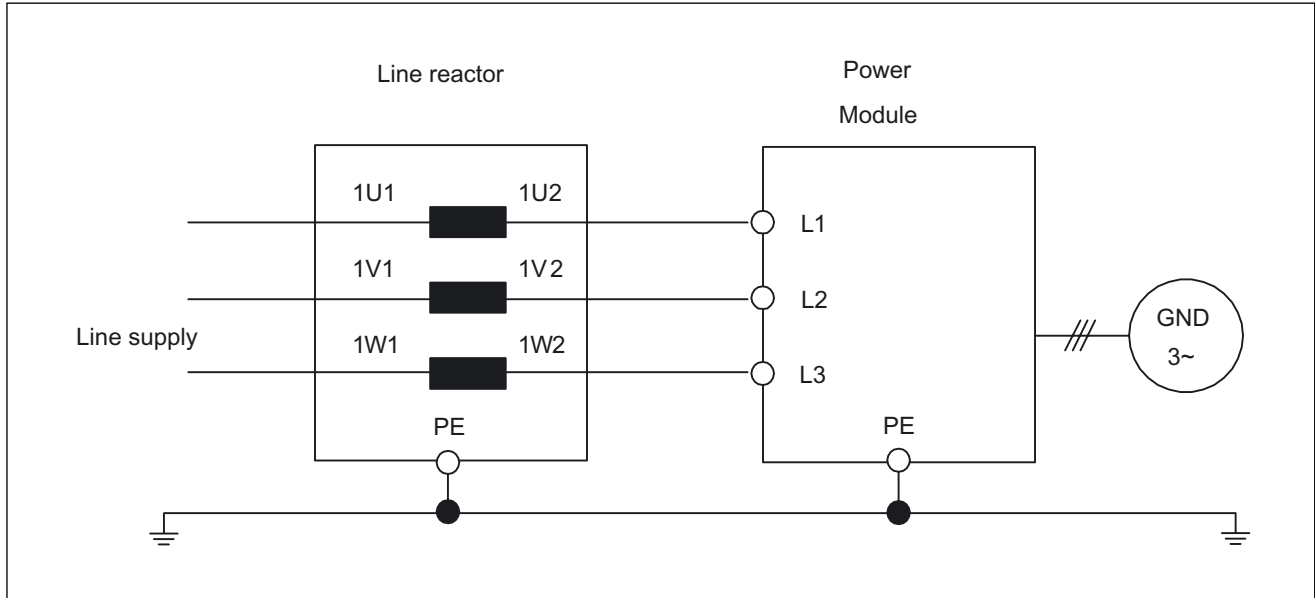

Figure 2-20 Power Module with line filter

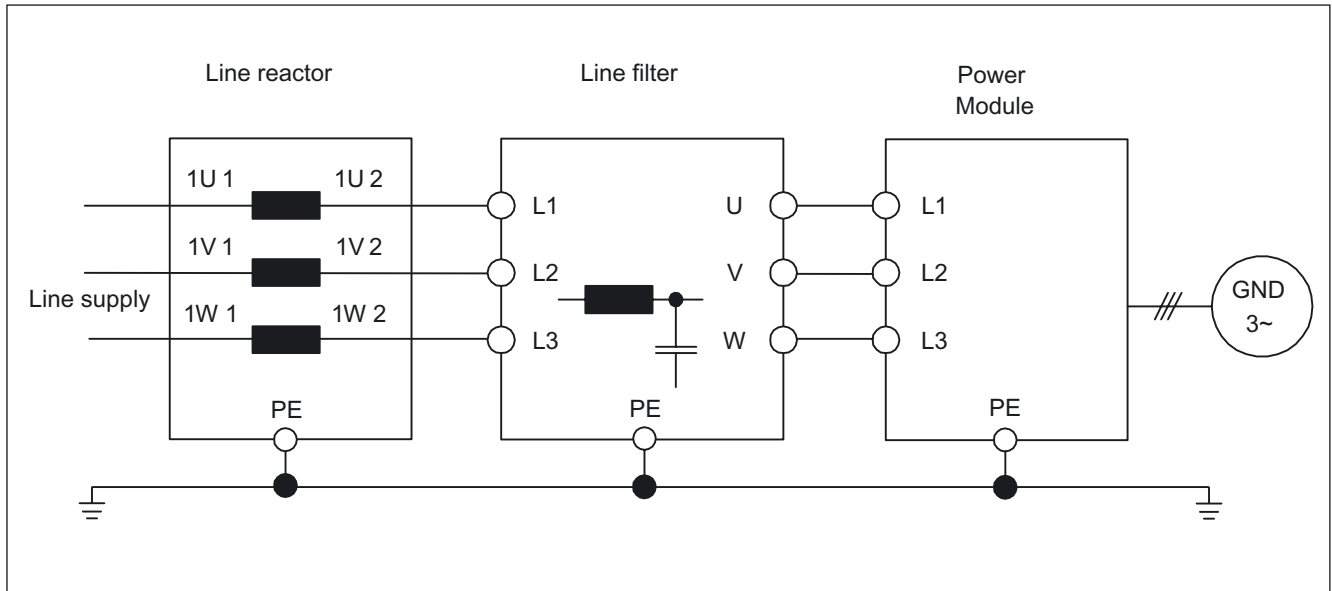

Figure 2-21 Power Module Blocksize with line reactor and line filter

## 2.4.7 Technical data, Blocksize

Table 2-12 Technical data, Blocksize line reactors, Part 1

Line supply voltage 1-ph 200 V AC -10 % to 240 V AC+10%			
Order No. 6SE6400-		3CC00-4AB3	3CC01-0AB3
Suitable for Power Module 6SL3210-		1SB11-0UA0	1SB14-0UA0
Rated line reactor current	A	3.4	8.1
Power loss 50 / 60 Hz	W	12.5 / 15	11.5 / 14.5
Line supply connection U1, V1, W1		6 mm screw terminals <sup>2</sup>	6 mm screw terminals <sup>2</sup>
Load connection 1U2, 1V2, 1W2		Cable 3 x AWG16 (3 x 1.5 mm <sup>2</sup> )	Cable 3 x AWG16 (3 x 1.5 mm <sup>2</sup> )
PE connection		M5 stud	M5 stud
Degree of protection		IP20 or IPXXB	IP20 or IPXXB
Weight	kg	1.3	1.3

Table 2-13 Technical data, Blocksize line reactors, Part 2

Line supply voltage 3-ph 380 V AC -10 % to 480 V AC +10%					
Order No.		6SE6400-3CC00-2AD3	6SE6400-3CC00-4AD3	6SE6400-3CC00-6AD3	6SL3203-0CD21-0AA0
Suitable for Power Module 6SL3210-		1SE11-3UA0 1SE11-7UA0 1SE12-2UA0	1SE13-1UA0	1SE14-1UA0	1SE16-0UA0
Rated line reactor current	A	1.9	3.5	4.8	9
Power loss 50 / 60 Hz	W	6 / 7	12.5 / 15	7.5 / 9	9 / 11
Line supply connection U1, V1, W1		6 mm screw terminals <sup>2</sup>	6 mm screw terminals <sup>2</sup>	6 mm screw terminals <sup>2</sup>	6 mm screw terminals <sup>2</sup>
Load connection 1U2, 1V2, 1W2		Cable 4 x AWG16 (1.5 mm <sup>2</sup> ) length approx. 0.38 m	Cable 4 x AWG16 (1.5 mm <sup>2</sup> ) length approx. 0.38 m	Cable 4 x AWG16 (1.5 mm <sup>2</sup> ) length approx. 0.38 m	Cable 4 x AWG16 (1.5 mm <sup>2</sup> ) length approx. 0.46 m
PE connection		At the housing with M5 stud	At the housing with M5 stud	At the housing with M5 stud	At the housing with M5 stud
Degree of protection		IP20 or IPXXB	IP20 or IPXXB	IP20 or IPXXB	IP20 or IPXXB
Weight	kg	1.2	1.3	1.3	3.4

Line-side power components

2.4 Line reactors

Table 2-14 Technical data, Blocksize line reactors, Part 3

Line supply voltage 3-ph 380 V AC -10 % to 480 V AC +10%					
Order No. 6SL3203-		0CD21-4AA0	0CD22-2AA0	0CD23-5AA0	0CJ24-5AA0
Suitable for Power Module 6SL3210-		1SE17-7UA0 1SE21-0UA0	1SE21-8UA0 1SE22-5UA0	1SE23-2UA0	1SE23-8UA0 1SE24-5UA0
Rated line reactor current	A	11.6	25	31.3	54
Power loss 50 / 60 Hz	W	27 / 32	98 / 118	37 / 44	90 / 115
Line supply connection U1, V1, W1		6 mm screw terminals <sup>2</sup>	6 mm screw terminals <sup>2</sup>	6 mm screw terminals <sup>2</sup>	16 mm screw terminals <sup>2</sup>
Load connection 1U2, 1V2, 1W2		Cable 4 x AWG16 (1.5 mm <sup>2</sup> ) length approx. 0.46 m	Cable 4 x AWG10 (2.5 mm <sup>2</sup> ) Length approx. 0.49 m	Cable 4 x AWG10 (2.5 mm <sup>2</sup> ) Length approx. 0.49 m	Cable 4 x 16 mm <sup>2</sup> Length approx. 0.70 m
PE connection		At the housing with M5 stud	At the housing with M5 stud	At the housing with M5 stud	At the housing with M8 screw
Degree of protection		IP20 or IPXXB	IP20 or IPXXB	IP20 or IPXXB	IP20 or IPXXB
Weight	kg	3.4	6.3	6.4	13

Table 2-15 Technical data, Blocksize line reactors, Part 4

Line supply voltage 3-ph 380 V AC -10 % to 480 V AC +10%					
Order No.		6SL3203-0CD25-3AA0	6SL3203-0CJ28-6AA0	6SE6400-3CC11-2FD0	6SE6400-3CC11-7FD0
Suitable for Power Module 6SL3210-		1SE26-0UA0	1SE27-5UA0 1SE31-0UA0	1SE31-1UA0 1SE31-5UA0	1SE31-8UA0
Rated line reactor current	A	71	105	178	225
Power loss 50 / 60 Hz	W	90 / 115	170 / 215	280 / 360	280 / 360
Line supply connection U1, V1, W1		16 mm screw terminals <sup>2</sup>	50 mm screw terminals <sup>2</sup>	Flat connector for M10 cable lug	Flat connector for M10 cable lug
Load connection 1U2, 1V2, 1W2		Cable 4 x 16 mm <sup>2</sup> Length approx. 0.70 m	Cable 4 x 35 mm <sup>2</sup> Length approx. 0.70 m	Flat connector for M10 cable lug	Flat connector for M10 cable lug
PE connection		At the housing with M8 screw	At the housing with M8 screw	At the housing with M8 bolt	At the housing with M8 bolt
Degree of protection		IP20 or IPXXB	IP20 or IPXXB	IP00	IP00
Weight	kg	13	19	25	25

## 2.4.8 Technical data, Chassis

Table 2-16 Technical data, Chassis line reactors

Order No.	6SL3000-	OCE32-3AA0	OCE32-8AA0	OCE33-3AA0	OCE35-1AA0	OCE35-1AA0
Suitable for Power Module	6SL3310-	1TE32-1AA0	1TE32-6AA0	1TE33-1AA0	1TE33-8AA0	1TE35-0AA0
Rated current of the Power Module	A	210	260	310	380	380
Rated voltage	V	3-ph. 380 V AC -10% to 3-ph. 480 V AC +10% (-15% < 1 min), 47 to 63 Hz				
Rated line reactor current	A	210	260	310	380	380
$I_{thmax}$	A	224	278	331	508	508
Power loss 50/60 Hz	kW	0.243/0.274	0.219/0.247	0.236/0.267	0.323/0.365	0.323/0.365
Line supply/load connection		Connection lugs M10	Connection lugs M10	Connection lugs M10	Connection lugs M12	Connection lugs M12
Degree of protection		IP00	IP00	IP00	IP00	IP00
Weight	kg	24.5	26	27.8	38	38



## Power Modules

### 3.1 Power Modules Blocksize (PM340)

#### 3.1.1 Description



The Power Modules, Blocksize format are designed as follows:

- Line side diode rectifier
- DC link electrolytic capacitors with pre-charging circuit
- Output inverter
- Chopper transistor for (external) braking resistor
- Power supply 24 V DC / 1A
- Gating unit, actual value sensing
- Fan to cool the power semiconductors



The Power Modules cover the power range from 0.12 kW to 90.0 kW and are available in versions with and without line filter.

3.1 Power Modules Blocksize (PM340)

Table 3-1 Overview, Power Modules 340 (selection)

 <p>The image shows a Power Module (230 V) frame size A. It is a black, rectangular unit with a silver-colored front panel. The front panel features three circular indicators and a green terminal block at the top. A warning label is visible on the lower left side of the front panel.</p>	 <p>The image shows a Power Module frame size B. It is a black, rectangular unit with a silver-colored front panel. The front panel features a green terminal block at the top, a green terminal block on the left side, and a warning label in the center. The unit has a more complex design with multiple ventilation slots and a larger terminal block.</p>
<p>Power Module (230 V) frame size A, with and without integrated line filter Power Module (400 V) frame size A, without integrated line filter</p>	<p>Power Module frame size B, with and without integrated line filter</p>



	
<p>Power Module frame size C, with and without integrated line filter</p>	<p>Power Module frame size D, without line filter</p>

3.1 Power Modules Blocksize (PM340)

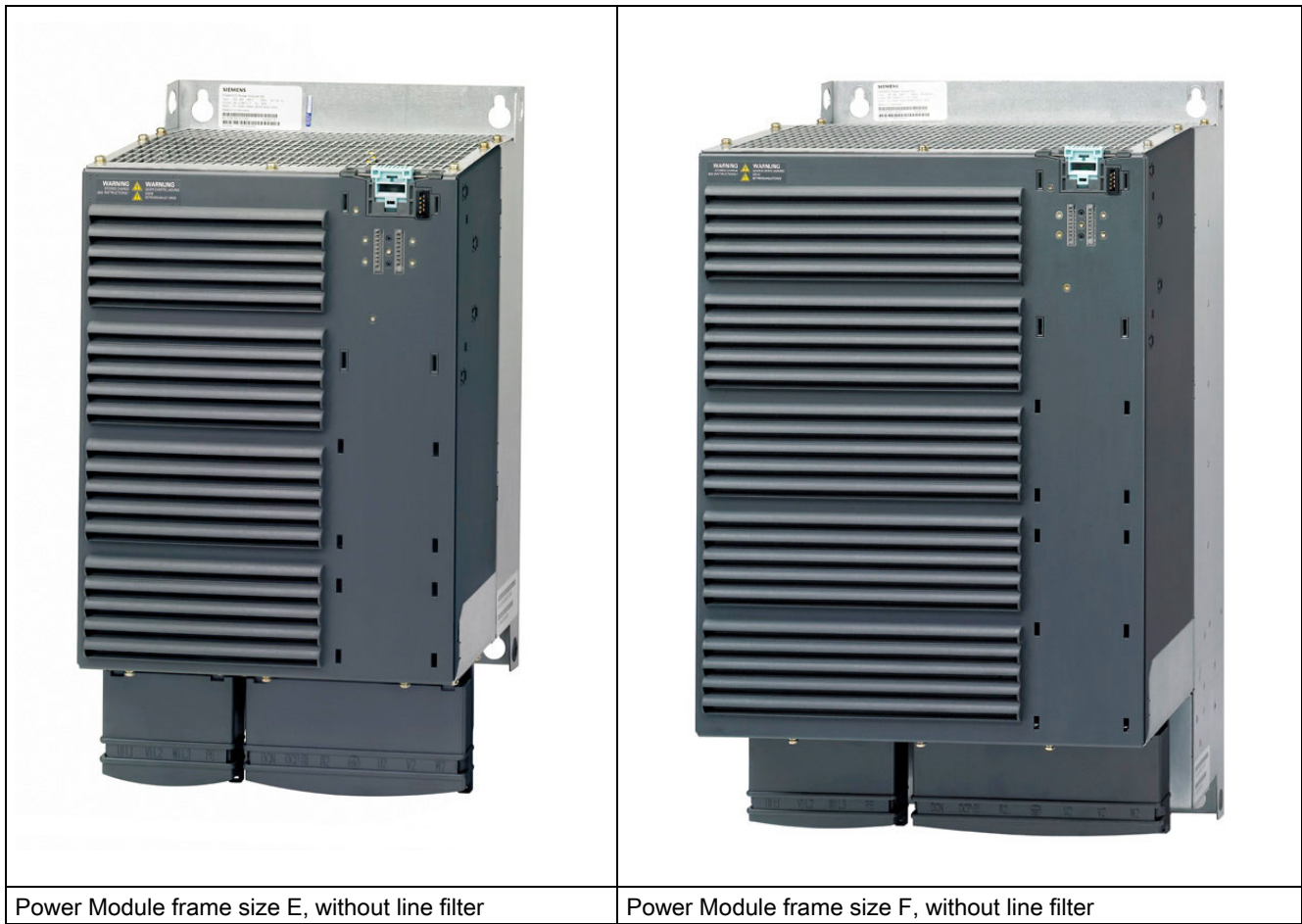

3.1.2 Safety information



**Caution**

During transport and during storage, Power Modules must be protected against mechanical shock and vibration. It is also important to protect the unit against water (rain) and against excessively high/excessively low temperatures.



**Danger**

**Grounding/protective grounding of the Power Module**

The Power Module housing must always be grounded. If the Power Module is not correctly grounded, then extremely hazardous states can occur, which under certain circumstances, can result in death.

**Danger**

It must be checked as to whether the Power Module is designed for the correct power supply voltage - higher supply voltages may not be connected to the Power Module.

**Danger**

After connecting the line and motor feeder cables to the appropriate terminals, it must be checked that the front covers (only frame sizes D and F) are closed and latched. Only then may the power module be connected to the supply voltage.

**Danger**

It must be checked to ensure that suitable protective circuit-breaker/fuses - with the specified rated currents - are installed between the line supply and the Power Module (refer to Technical Data).

Only UL-listed copper cables may be used.

**Danger**

After disconnecting all the supply voltages, a hazardous voltage will be present in all components for another 5 minutes. The cover for the terminals may only be opened after this time has definitely elapsed.

When opening the protective cover, you must activate the release. A suitable tool (e.g. screwdriver) must be used for this purpose.

Damaged components must not be used, otherwise this could result in secondary damage or accidents.

**Danger**

The Power Modules conduct a high leakage current. Because of the high leakage current of the Power Modules, a protective conductor must be permanently connected to the Power Modules or permanently connected to the electrical cabinet.

Measures according to EN 61800-5-1 must be taken (e.g. PE conductor ( $\geq 10 \text{ mm}^2 \text{ Cu}$ ) or fit an additional connection terminal for a PE conductor with the same cross-section as the original PE conductor).



**Caution**

Power Modules must be mounted in the vertical position.

For the Power Modules, the following cooling clearances must be maintained above and below the component:

- frame sizes A and B: 100 mm (3.93 inch),
- frame size C: 125 mm (4.92 inches),
- frame sizes D and E 300 mm (11.81 inches) and
- frame size F: 350 mm (13.77 inches).

When mounting the Power Modules, the following clearances must be maintained between the components:

- frame size B: 40 mm (1.57 inch)
- frame size C: 50 mm (1.96 inch)

Power Modules frame sizes A, D, E and F can be mounted without any lateral clearance.

Devices, that could restrict the cooling air flow may not be mounted/installed in this area. It must be carefully ensured that the cooling air flow of the Power Modules can flow unrestricted.

---



**Danger**

Cable shields and unused power cable conductors (e.g. brake conductors) must be connected to PE potential to prevent capacitive cross-talk charges.

Non-observance can cause lethal shock voltages.

---

### 3.1.3 Interface description

#### 3.1.3.1 Overview

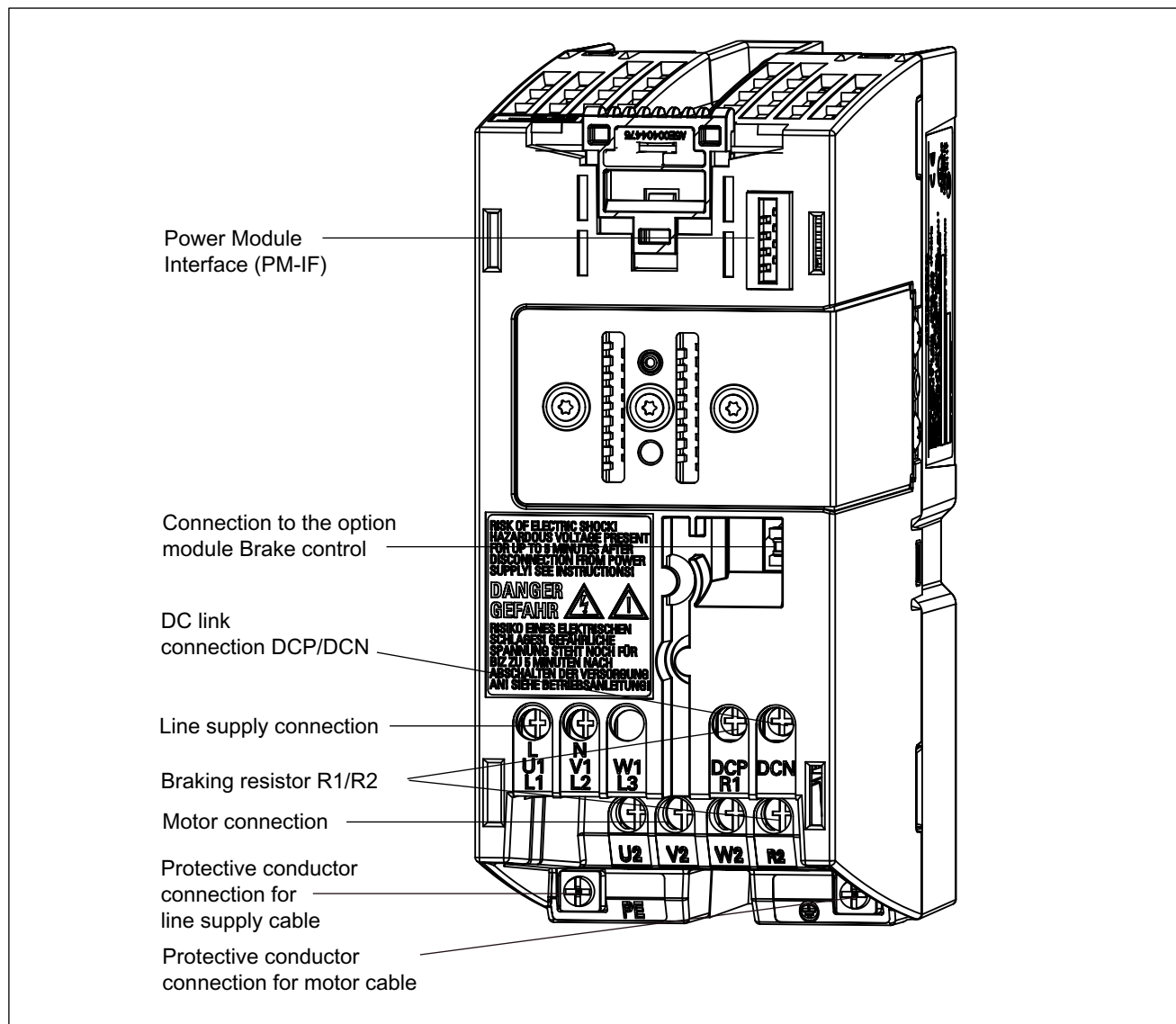

Figure 3-1 PM340, frame size A

3.1 Power Modules Blocksize (PM340)

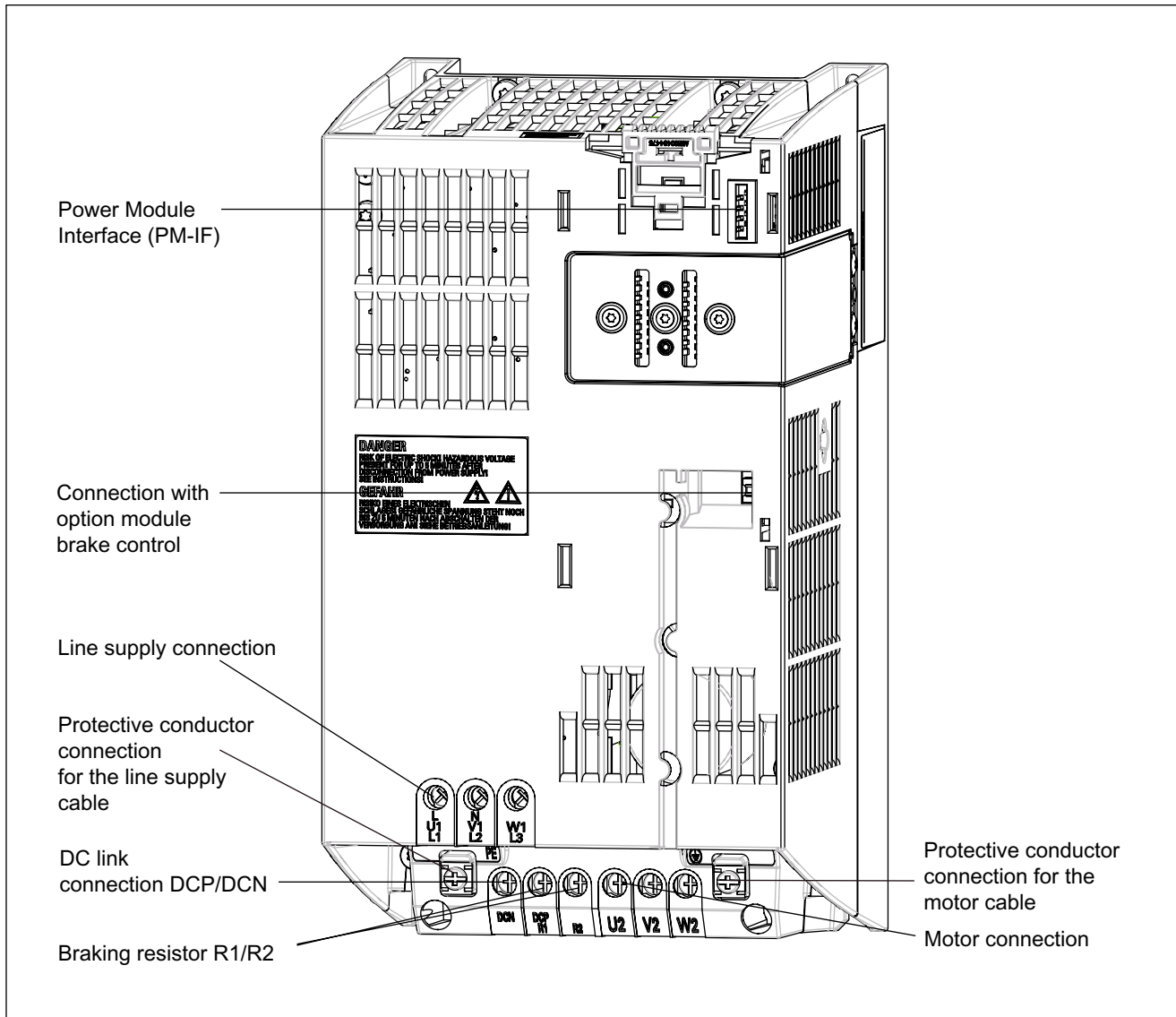

Figure 3-2 PM340, frame size B

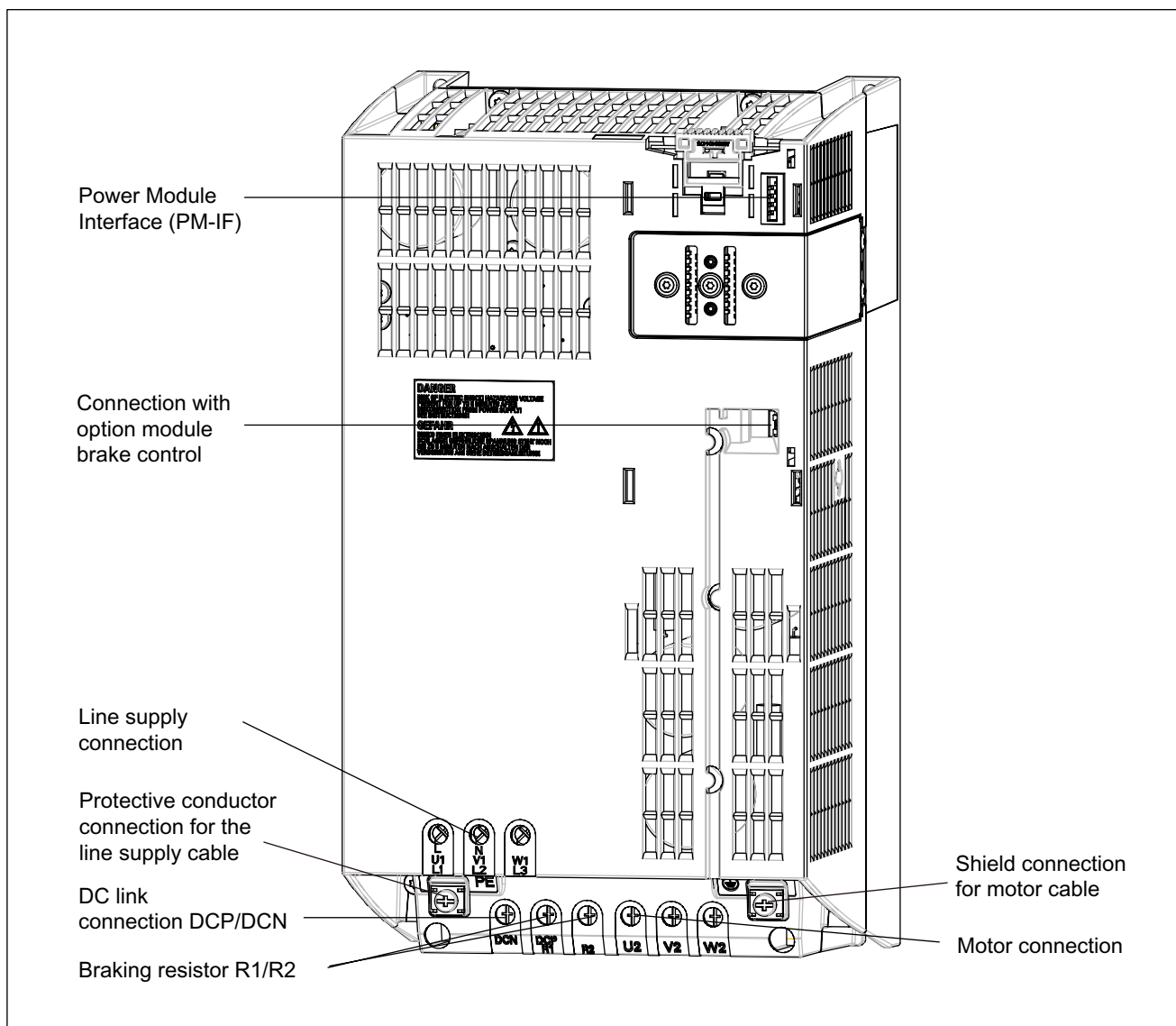

Figure 3-3 PM340, frame size C

3.1 Power Modules Blocksize (PM340)

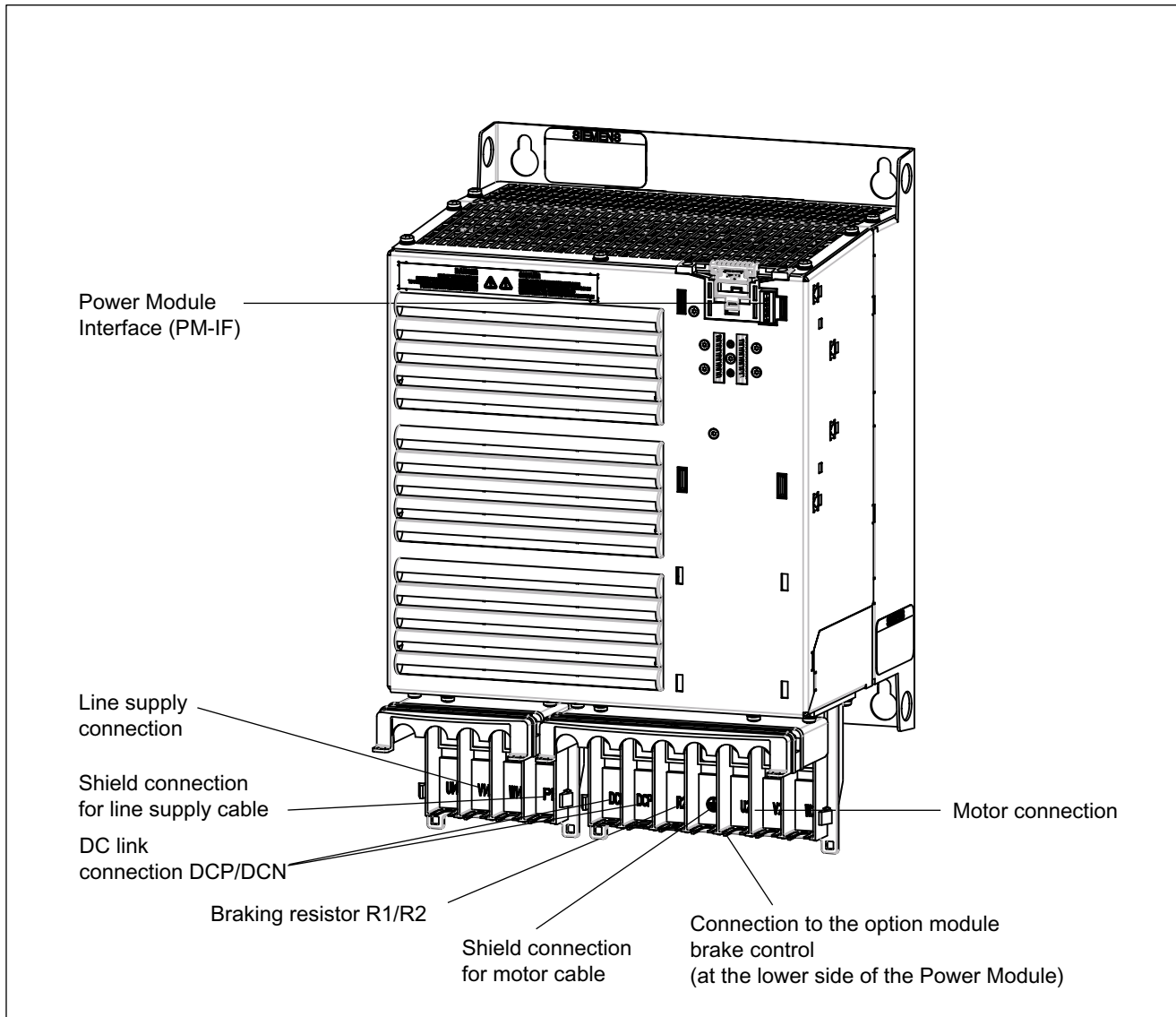

Figure 3-4 PM340, frame size D



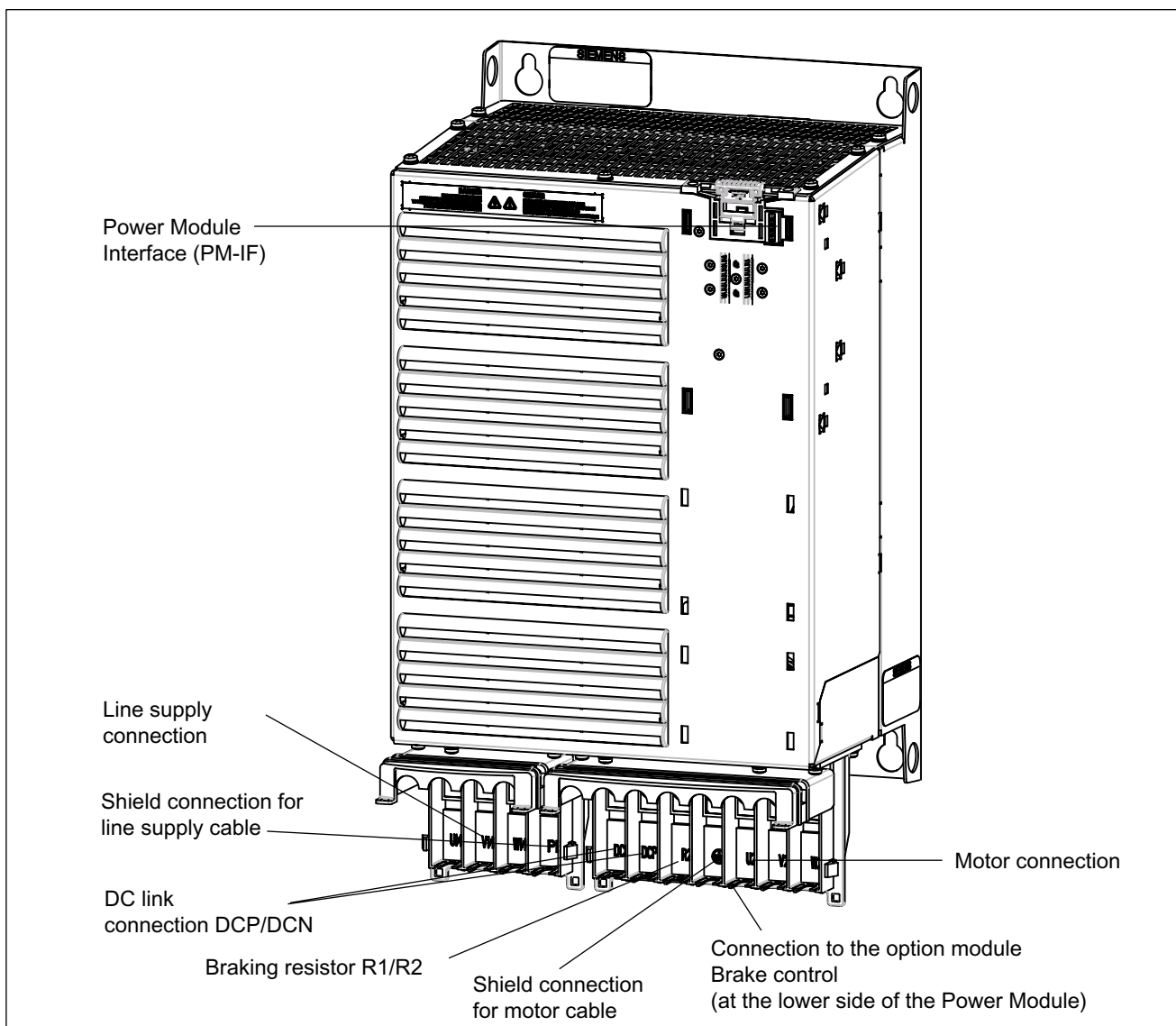

Figure 3-5 PM340, frame size E

3.1 Power Modules Blocksize (PM340)

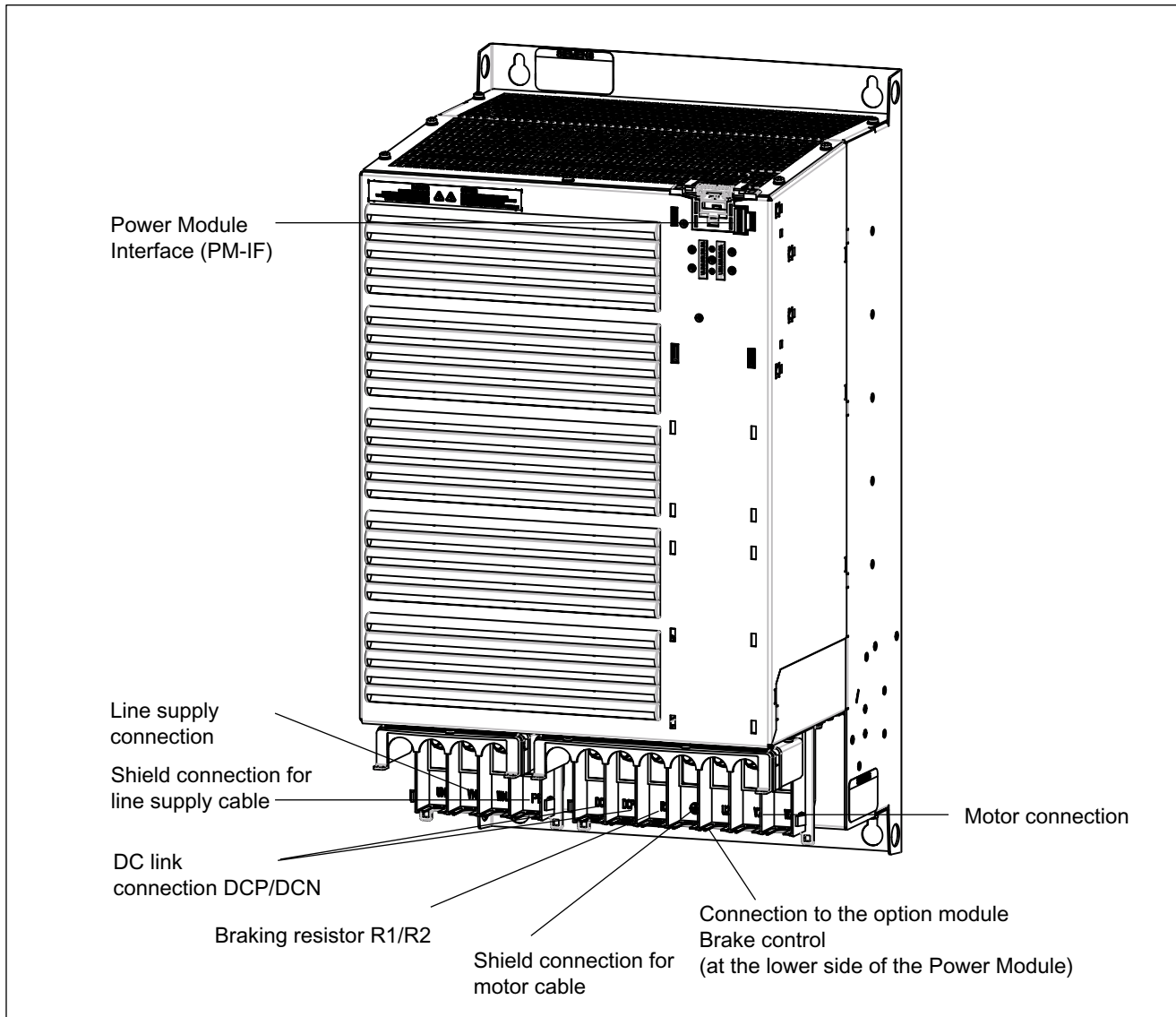

Figure 3-6 PM340, frame size F

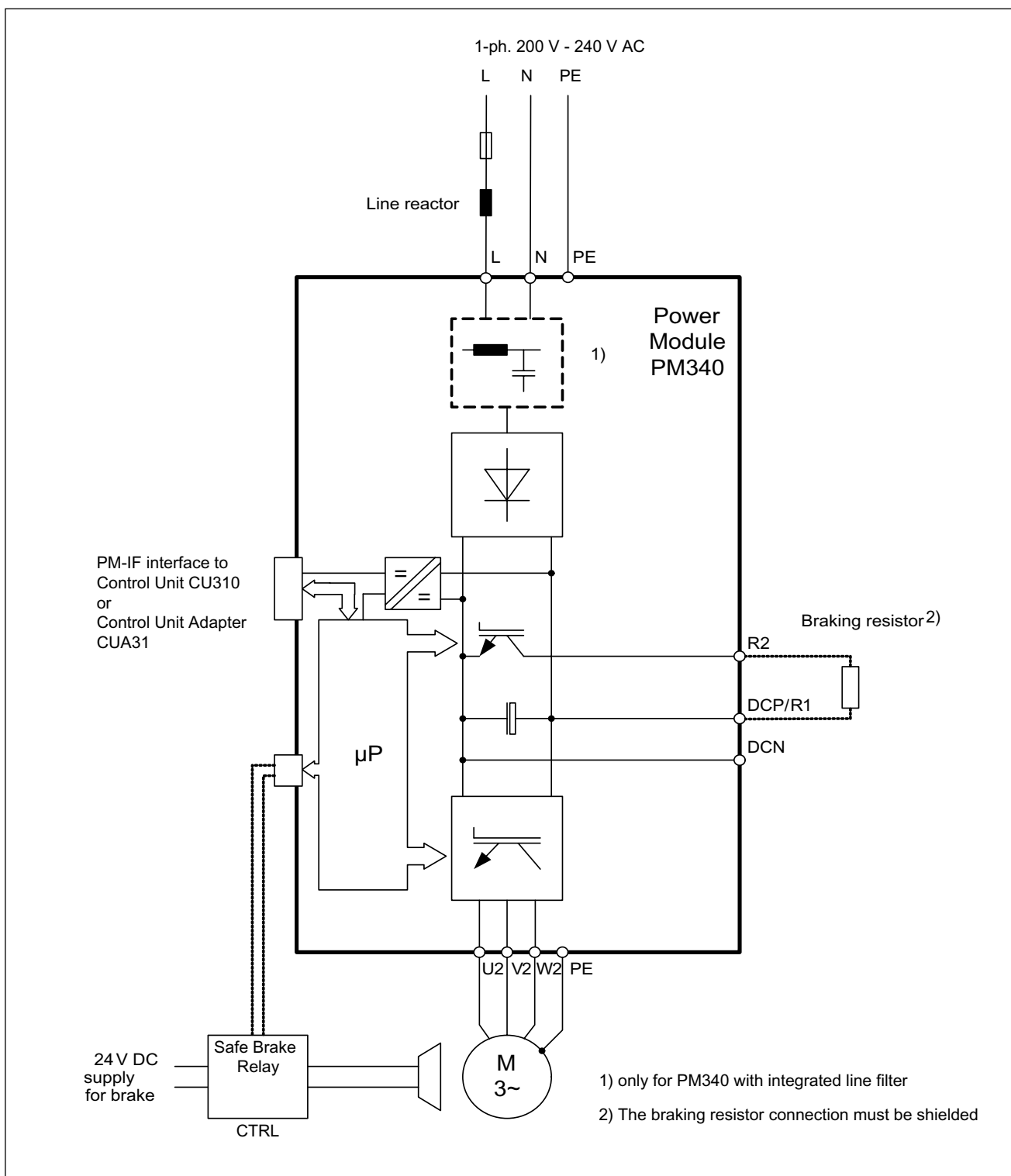

Figure 3-7 Connection example PM340, 1-ph. 200 V - 240 V AC

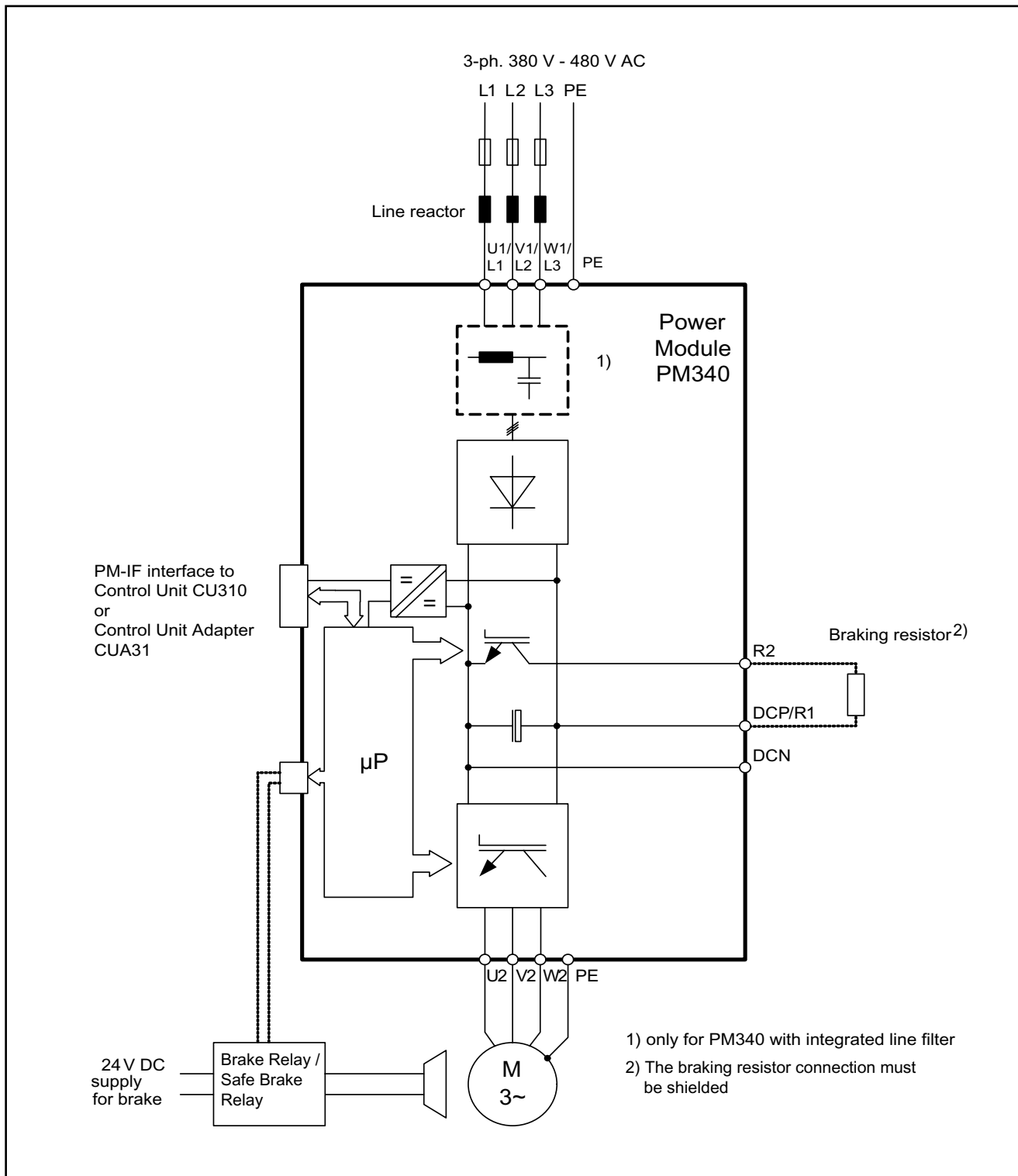

Figure 3-8 Connection example PM340, 3-ph. 380 V - 480 V AC

**Arrangement of the line supply and motor terminals.**

The arrangement of the line supply and motor terminals for frame sizes A to F of the Power Module 340 are shown in the following diagram. The diagram also shows the tightening torques for the terminals.

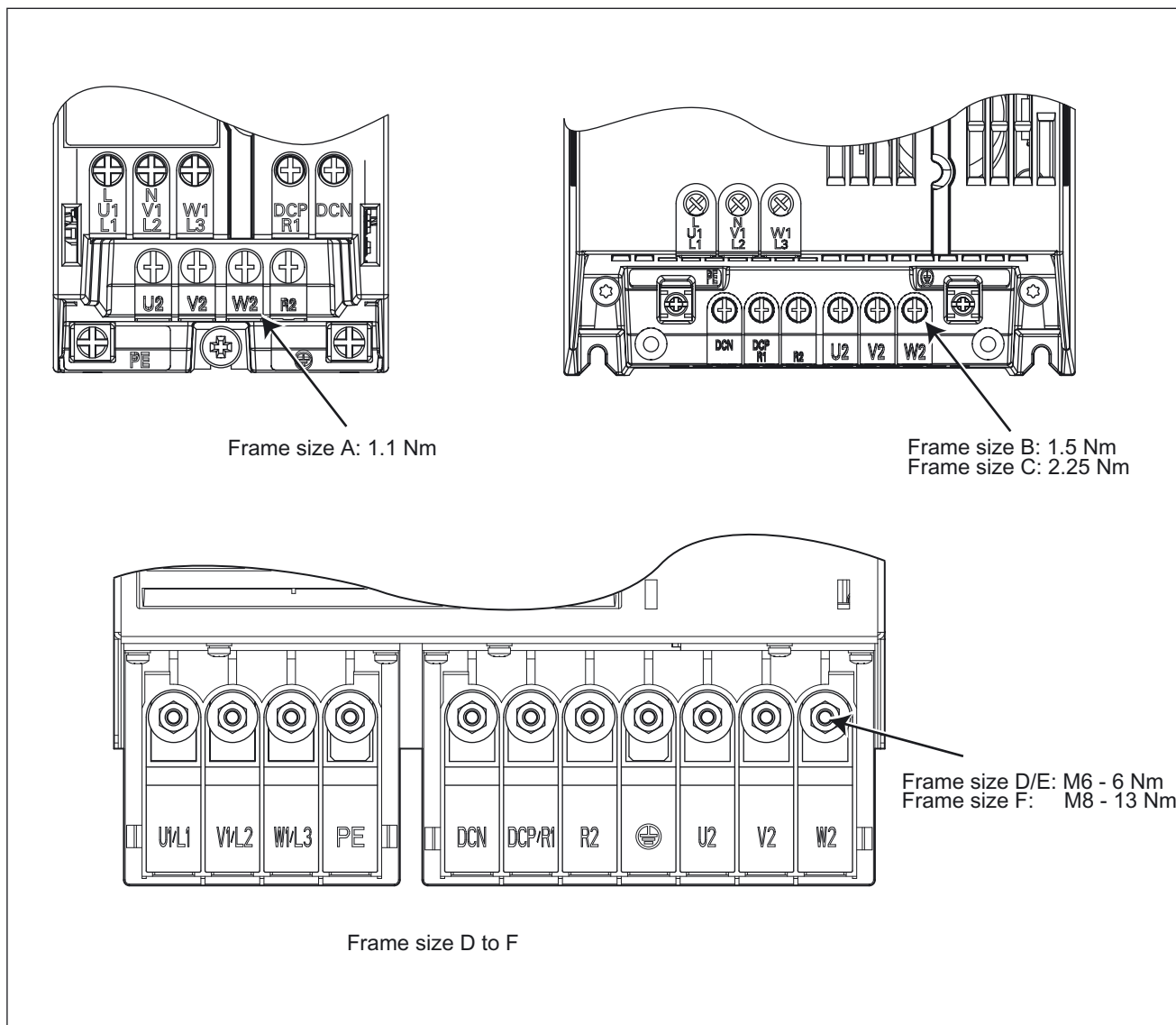

Figure 3-9 Arrangement of the line supply and motor terminals for the PM340

3.1 Power Modules Blocksize (PM340)

3.1.3.2 Line supply connection

Table 3-2 Terminal strip, line supply connection 1-ph. 200 V - 240 V AC



	Terminal	Signal name	Technical specifications
	1	L	Line phase L
	2	N	Line phase N
Max. conductor cross-section: 2.5 mm <sup>2</sup>			

Table 3-3 Terminal strip, line supply connection 3-ph. 380 V - 480 V AC

	Terminal	Signal name	Technical specifications
	1	L1	Line phase L1
	2	L2	Line phase L2
	3	L3	Line phase L3
	4	PE	PE connection
Max. conductor cross-section: 2.5 mm <sup>2</sup>			

### 3.1.3.3 Motor connection

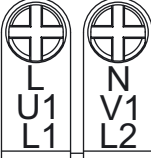
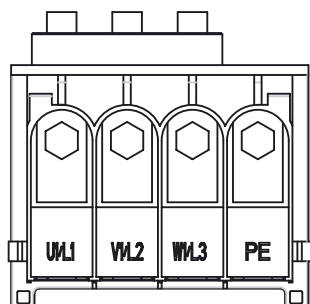
Table 3-4 Terminal strip, motor connection 1-ph. 200 V - 240 V AC and 3-ph. 380 V - 480 V AC

Terminal	Designation	Technical specifications
1	DCN	DC link negative
2	DCP/R1	DC link positive and position connection of the braking resistor
3	R2	Negative connection for the braking resistor
4		PE connection
5	U2	Motor phase U
6	V2	Motor phase V
7	W2	Motor phase W

Frame size A: Max. conductor cross-section 2.5 mm<sup>2</sup>

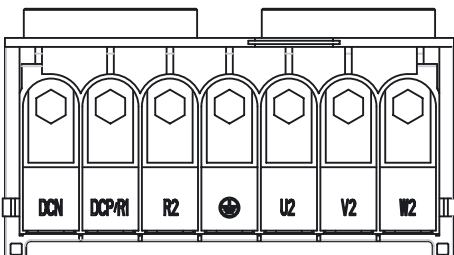

### 3.1.3.4 Connection to the option module, brake control

Table 3-5 Connector

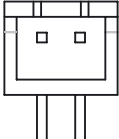
	Terminal 1	Designation	Technical specifications
	1	Low	Low signal, option module brake control at PM340
	2	High	High signal, option module brake control at PM340

### 3.1.3.5 Braking resistor R1/R2

Table 3-6 Terminal strip R1/R2

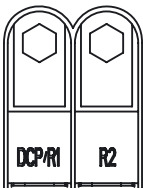
	Terminal	Technical specifications
	R1	Braking resistor connection
	R2	Braking resistor connection

3.1.4 Dimension drawings

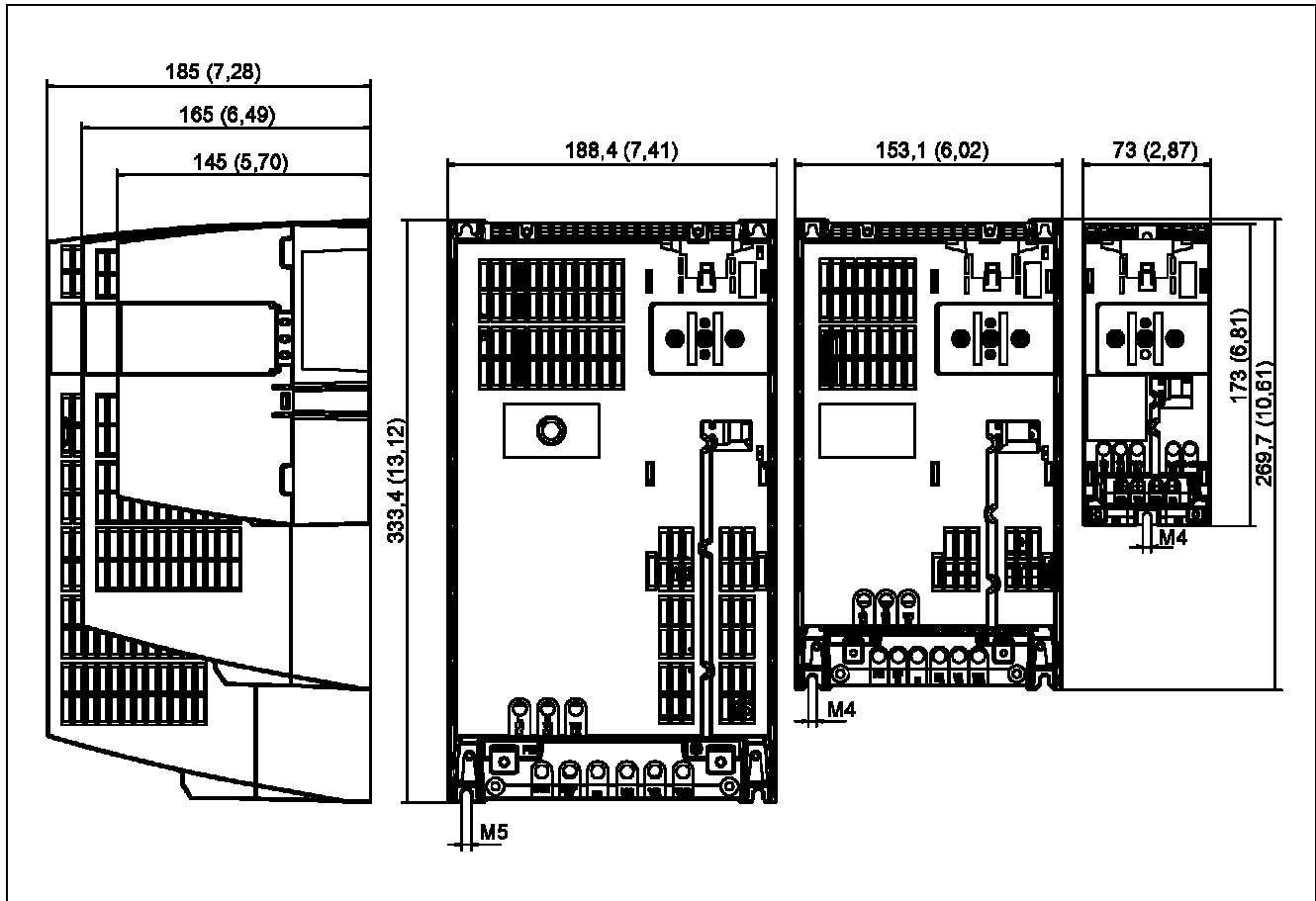

Figure 3-10 Dimension drawings, Power module PM340

Frame size C

Frame size B

Frame size A



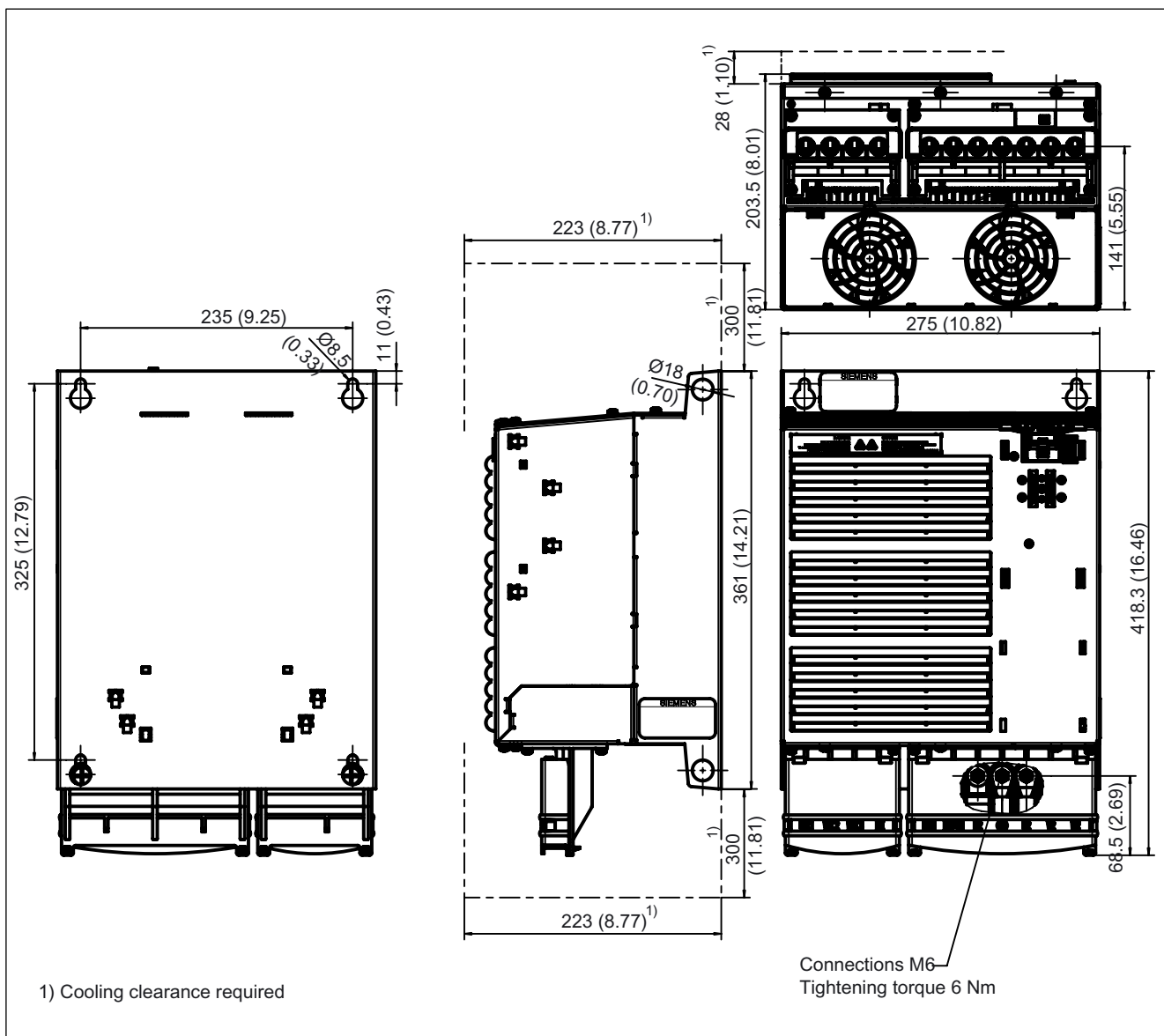

Figure 3-11 Dimension drawing: Power Module 340, frame size D

3.1 Power Modules Blocksize (PM340)

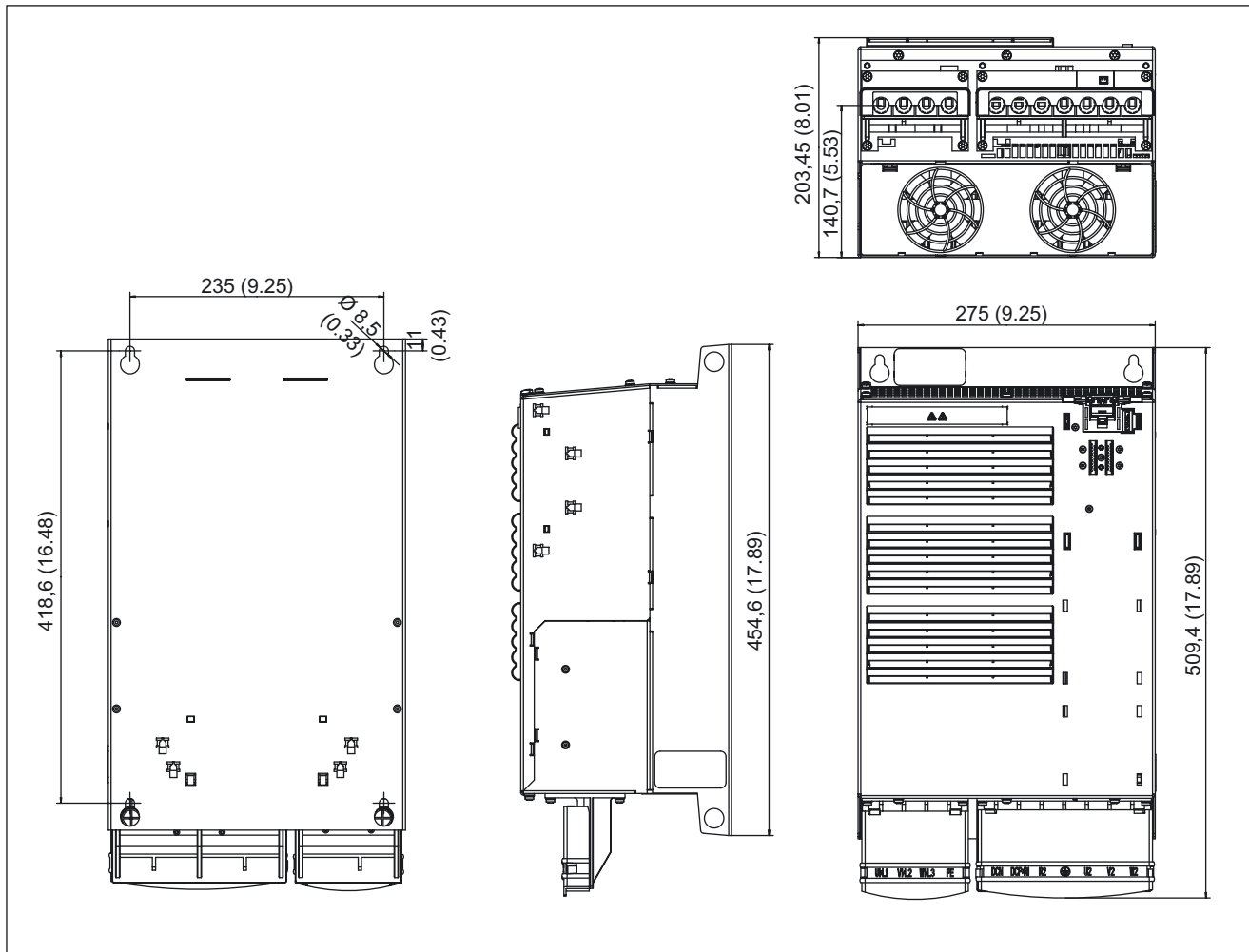

Figure 3-12 Dimension drawing: Power Module 340, with integrated line filter, frame size D

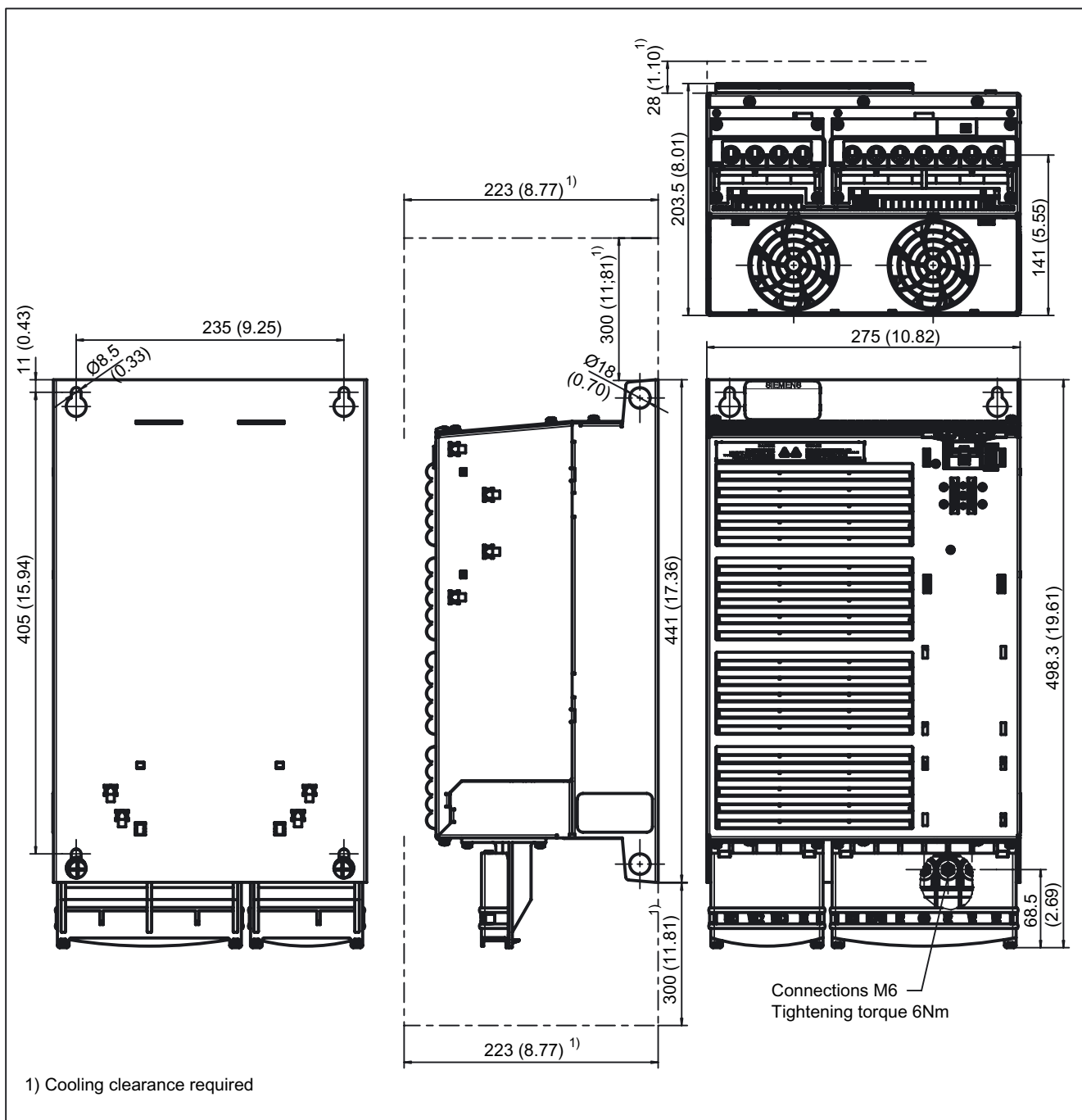

Figure 3-13 Dimension drawing: Power Module 340, frame size E

3.1 Power Modules Blocksize (PM340)

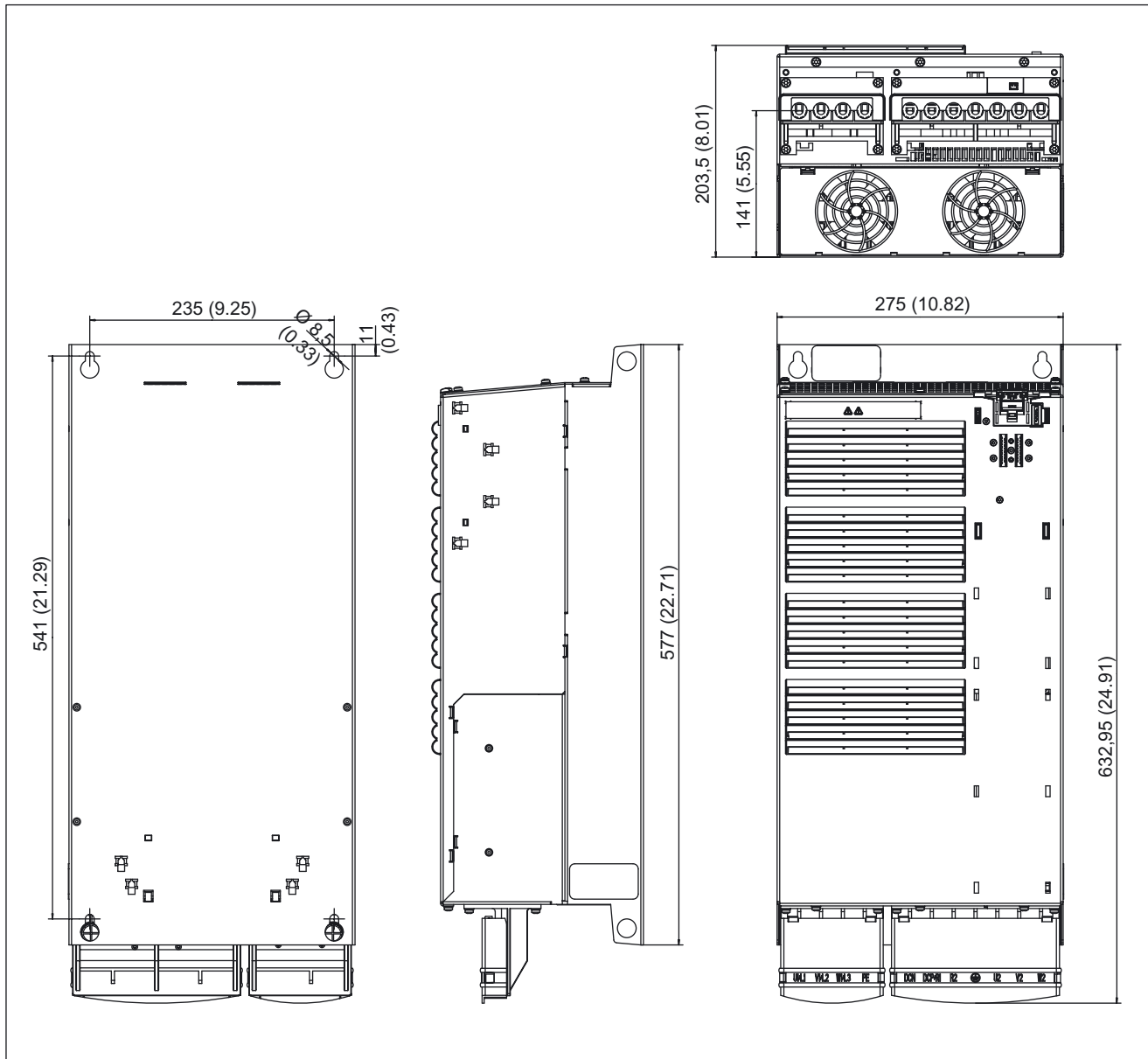

Figure 3-14 Dimension drawing: Power Module 340, with integrated line filter, frame size E

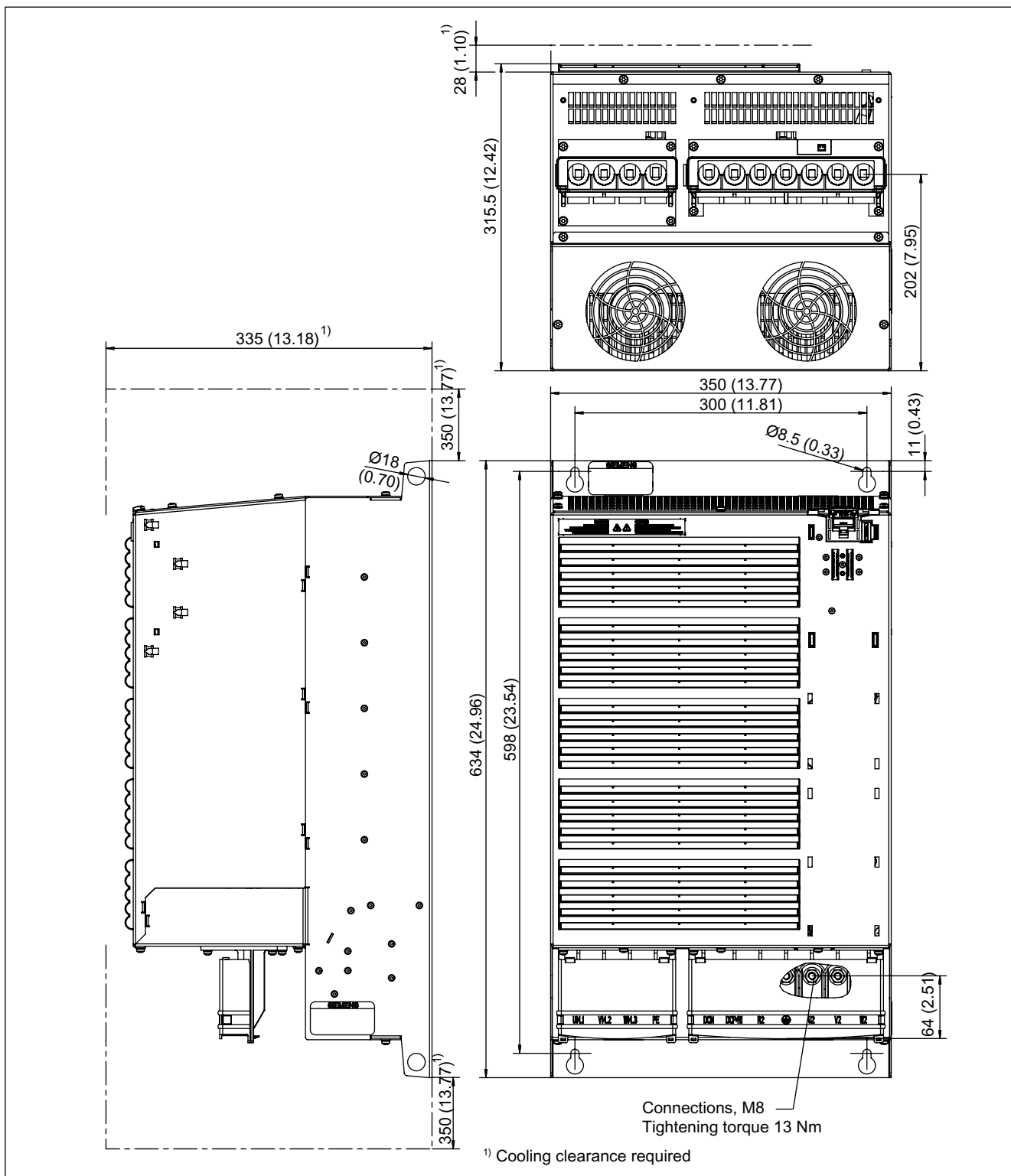

Figure 3-15 Dimension drawing: Power Module 340, frame size F

3.1 Power Modules Blocksize (PM340)

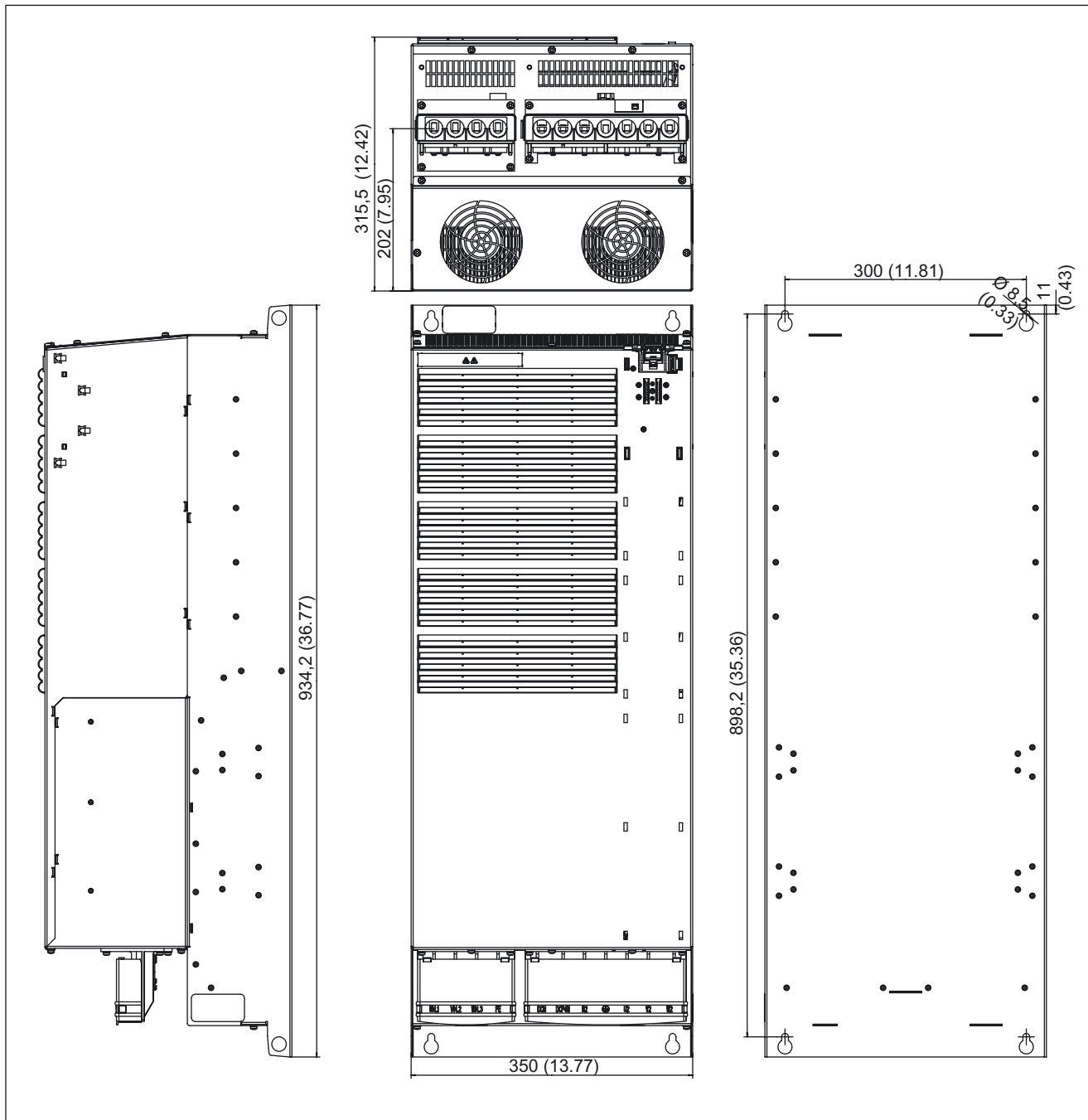

Figure 3-16 Dimension drawing: Power Module PM340, with integrated line filter, frame size F

### 3.1.5 Mounting

#### Drilling templates for frame sizes A to C

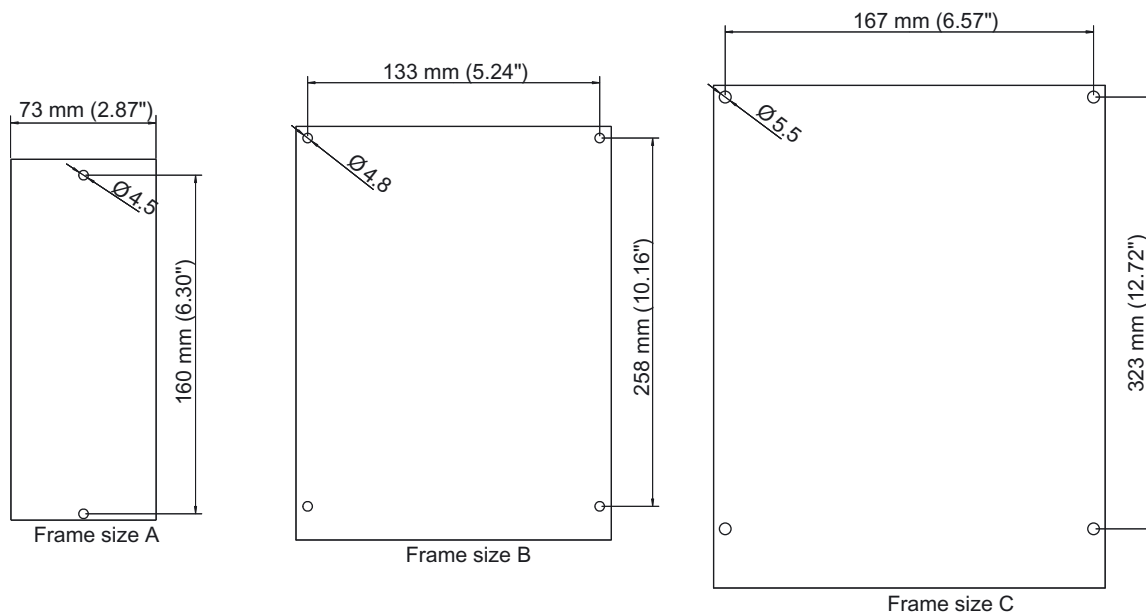

Figure 3-17 Drilling templates for frame sizes A to C

Drilling templates for frame sizes D to F

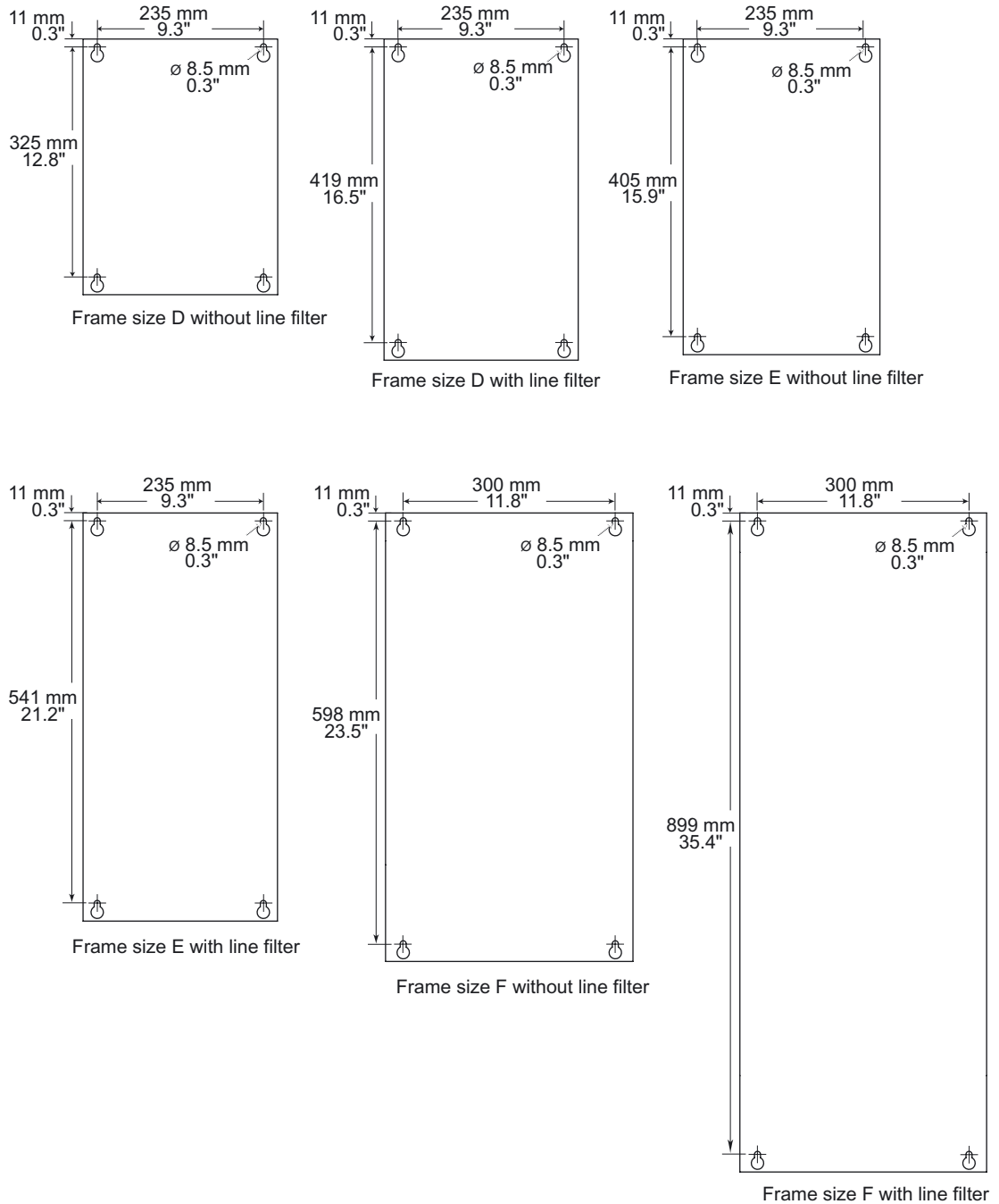

Figure 3-18 Drilling templates for frame sizes D to F - with and without line filter



The dimensions and the tightening torques when retaining the Power Modules are specified in the following table.

Table 3-7 PM340, dimensions and tightening torques when mounting

Frame size	Height, width, depth		Dimensions (with Control Unit)	Retaining type	Tightening torques
A	HxWxD	mm	173 x 73 x 118.2	Each 2 M4 bolts, nuts and washers	2.5 Nm with washers
		Inches	6.81 x 2.87 x 4.65		
B	HxWxD	mm	203.3 x 149 x 140.7	Each 4 M4 bolts, nuts and washers	
		Inches	8.0 x 5.87 x 5.54		
C	HxWxD	mm	247 x 185 x 163.7		
		Inches	9.72 x 7.28 x 6.44		
D Without line filter	HxWxD	mm	417 x 275 x 203.5	Each 4 M8 bolts, nuts and washers	13 Nm with washers
		Inches	16.4 x 10.8 x 8.0		
D With integrated line filter	HxWxD	mm	511 x 275 x 203.5		
		Inches	20.1 x 10.8 x 8.0		
E Without line filter	HxWxD	mm	497 x 275 x 203.5		
		Inches	19.6 x 10.8 x 8.0		
E With integrated line filter	HxWxD	mm	633 x 275 x 203.5		
		Inches	24.9 x 10.8 x 8.0		
F Without line filter	HxWxD	mm	634 x 350 x 315.5		
		Inches	25.0 x 13.8 x 12.4		
F With integrated line filter	HxWxD	mm	934 x 350 x 315.5		
		Inches	36.8 x 13.8 x 12.4		

Table 3-8 PM340, load terminals - tightening torques

Frame size	Tightening torques	
A	Nm	1.1
B	Nm	1.5
C	Nm	2.25
D	Nm	6
E	Nm	6
F	Nm	13

For frame sizes D to F, the terminals are accessed by releasing the tongue at the side of the terminal covers using a suitable flat screwdriver. The cover can then be pushed upwards and engaged in this position as shown in the following diagram.

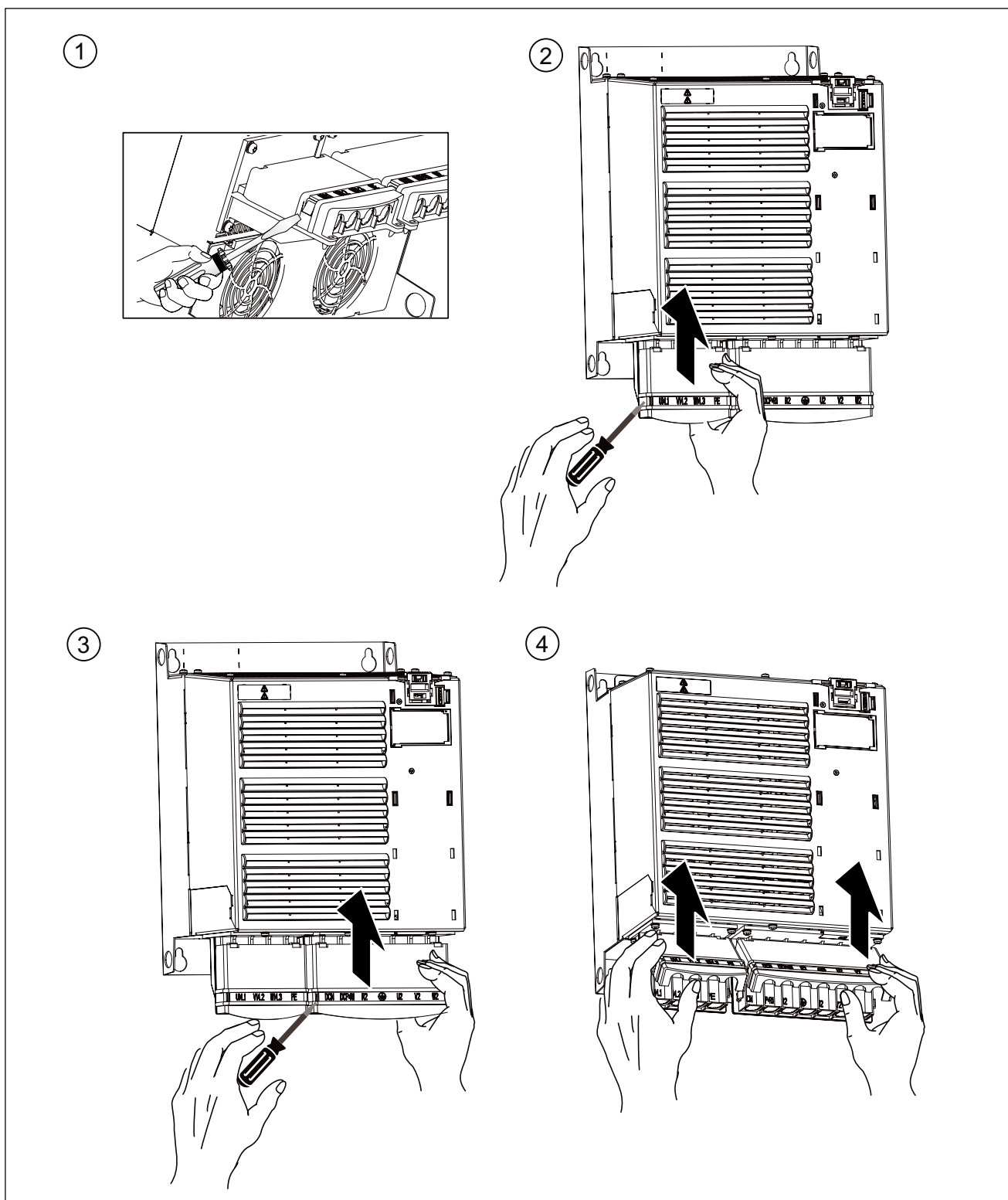

Figure 3-19 Access to the line and motor terminals for frame sizes D to F

### 3.1.6 Electrical installation

#### Operation on non-grounded line supply systems (IT)

It is not permissible to use Power Modules with series line filter in IT line supply systems.

In order that the Power Modules remain functional when ground faults occur, a line reactor must be connected in series.

### 3.1.7 Technical data

Table 3-9 Technical data PM340, Part 1

Line supply voltage 1-ph. 230 V AC ± 10 %				
PM340	6SL3210-	1SB11-0UA0	1SB12-3UA0	1SB14-0UA0
PM340 with integrated line filter	6SL3210-	1SB11-0AA0	1SB12-3AA0	1SB14-0AA0
Rated output current $I_n$	A	0.9	2.3	3.9
Base load current ( $I_H$ )	A	0.8	2.0	3.4
Output current for S6 duty (40%) $I_{S6}$	A	1.4	3.3	5.5
Max. output current ( $I_{max}$ )	A	2.0	4.6	7.8
Rated power based on $I_n$	kW	0.12	0.37	0.75
Rated pulse frequency	kHz	4	4	4
Efficiency $\eta$		0.80	0.90	0.91
Power loss	kW	0.06	0.075	0.11
Cooling air requirement	m <sup>3</sup> /s	0.005	0.005	0.005
Sound pressure level	dB(A)	< 45	< 45	< 45
24 V DC power supply for the Control Unit	A	1.0	1.0	1.0
Rated input current <sup>1)</sup> with line reactor	A	1.9	4.8	8
without line reactor		2.2	6.0	10
Resistance value of the external braking resistor	Ohm	≥ 180	≥ 180	≥ 180
Max. cable length to braking resistor	m	15	15	15
Line supply connection L, N		Screw terminals for cable cross-sections 1.0 to 2.5 mm <sup>2</sup>	Screw terminals for cable cross-sections 1.0 to 2.5 mm <sup>2</sup>	Screw terminals for cable cross-sections 1.0 to 2.5 mm <sup>2</sup>
Motor connection U2, V2, W2		Screw terminals for cable cross-sections 1.0 to 2.5 mm <sup>2</sup>	Screw terminals for cable cross-sections 1.0 to 2.5 mm <sup>2</sup>	Screw terminals for cable cross-sections 1.0 to 2.5 mm <sup>2</sup>
DC link connection, connection for braking resistor DCP/R1, DCN, R2		Screw terminals for cable cross-sections 1.0 to 2.5 mm <sup>2</sup>	Screw terminals for cable cross-sections 1.0 to 2.5 mm <sup>2</sup>	Screw terminals for cable cross-sections 1.0 to 2.5 mm <sup>2</sup>
PE connection		at the housing with M 4 screw	at the housing with M 4 screw	at the housing with M 4 screw

Line supply voltage 1-ph. 230 V AC $\pm$ 10 %				
PM340	6SL3210-	1SB11-0UA0	1SB12-3UA0	1SB14-0UA0
PM340 with integrated line filter	6SL3210-	1SB11-0AA0	1SB12-3AA0	1SB14-0AA0
Max. motor cable length <sup>1)</sup> (without external options)	m	50 (shielded) 75 (non-shielded)	50 (shielded) 75 (non-shielded)	50 (shielded) 75 (non-shielded)
Degree of protection		IP20 or IPXXB	IP20 or IPXXB	IP20 or IPXXB
Depth				
- PM340 with Control Unit CU310	mm	234.6 (9.23)	234.6 (9.23)	234.6 (9.23)
- PM340 with CUA31		175.3 (6.90)	175.3 (6.90)	175.3 (6.90)
Frame size		A	A	A
Weight, approx.	kg	1.2	1.2	1.3

1) The input current depends on the motor load and line impedance. The input currents apply for load with the rated power (based on  $I_n$ ) for a line impedance corresponding to  $u_k = 1\%$ .

2) Max. motor cable length 50 m (shielded) for Power Modules PM340 with integrated line filter to maintain the limit values of EN 61800-3 Category C2.

Table 3-10 Technical data PM340, Part 2

Line voltage 3-ph. 380 V to 480 V AC						
PM340	6SL3210-	1SE11-3UA0	1SE11-7UA0	1SE12-2UA0	1SE13-1UA0	1SE14-1UA0
PM340 with integrated line filter	6SL3210-	1SE11-3AA0	1SE11-7AA0	1SE12-2AA0	1SE13-1AA0	1SE14-1AA0
Rated output current $I_n$	A	1.3	1.7	2.2	3.1	4.1
Base load current $I_H$	A	1.1	1.5	1.9	2.7	3.6
Output current for S6 duty (40%) $I_{S6}$	A	1.3	2.0	2.5	3.5	4.5
Max. output current $I_{max}$	A	2.6	3.4	4.4	6.2	8.2
Rated power based on $I_n$	kW	0.37	0.55	0.75	1.1	1.5
Rated power based on $I_H$	kW	0.37	0.55	0.75	1.1	1.5
Rated pulse frequency	kHz	4	4	4	4	4
Efficiency $\eta$		0.97	0.97	0.97	0.97	0.97
Power loss	kW	0.097	0.099	0.102	0.108	0.114
Cooling air requirement	m <sup>3</sup> /s	0.005	0.005	0.005	0.005	0.005
Sound pressure level	dB(A)	< 45	< 45	< 45	< 45	< 45
24 V DC power supply for the Control Unit	A	1.0	1.0	1.0	1.0	1.0
Rated input current <sup>1)</sup> - with line reactor - without line reactor	A	1.4 1.7	1.8 2.2	2.3 2.6	3.2 3.9	4.3 4.8
Resistance value of the external braking resistor	Ohm	$\geq 390$	$\geq 390$	$\geq 390$	$\geq 390$	$\geq 390$
Max. cable length to braking resistor	m	15	15	15	15	15

3.1 Power Modules Blocksize (PM340)

Line voltage 3-ph. 380 V to 480 V AC						
PM340	6SL3210-	1SE11-3UA0	1SE11-7UA0	1SE12-2UA0	1SE13-1UA0	1SE14-1UA0
PM340 with integrated line filter	6SL3210-	1SE11-3AA0	1SE11-7AA0	1SE12-2AA0	1SE13-1AA0	1SE14-1AA0
Line supply connection U1/L1, V1/L2, W1/L3		Screw terminals for cable cross-sections 1.0 to 2.5 mm <sup>2</sup>	Screw terminals for cable cross-sections 1.0 to 2.5 mm <sup>2</sup>	Screw terminals for cable cross-sections 1.0 to 2.5 mm <sup>2</sup>	Screw terminals for cable cross-sections 1.0 to 2.5 mm <sup>2</sup>	Screw terminals for cable cross-sections 1.0 to 2.5 mm <sup>2</sup>
Motor connection U2, V2, W2		Screw terminals for cable cross-sections 1.0 to 2.5 mm <sup>2</sup>	Screw terminals for cable cross-sections 1.0 to 2.5 mm <sup>2</sup>	Screw terminals for cable cross-sections 1.0 to 2.5 mm <sup>2</sup>	Screw terminals for cable cross-sections 1.0 to 2.5 mm <sup>2</sup>	Screw terminals for cable cross-sections 1.0 to 2.5 mm <sup>2</sup>
DC link connection, connection for braking resistor DCP/R1, DCN, R2		Screw terminals for cable cross-sections 1.0 to 2.5 mm <sup>2</sup>	Screw terminals for cable cross-sections 1.0 to 2.5 mm <sup>2</sup>	Screw terminals for cable cross-sections 1.0 to 2.5 mm <sup>2</sup>	Screw terminals for cable cross-sections 1.0 to 2.5 mm <sup>2</sup>	Screw terminals for cable cross-sections 1.0 to 2.5 mm <sup>2</sup>
PE connection		at the housing with M 4 screw	at the housing with M 4 screw	at the housing with M 4 screw	at the housing with M 4 screw	at the housing with M 4 screw
Max. motor cable length <sup>2)</sup>	m	50 (shielded) 75 (non-shielded)	50 (shielded) 75 (non-shielded)	50 (shielded) 75 (non-shielded)	50 (shielded) 75 (non-shielded)	50 (shielded) 75 (non-shielded)
Degree of protection		IP20 or IPXXB	IP20 or IPXXB	IP20 or IPXXB	IP20 or IPXXB	IP20 or IPXXB
Depth - PM340 with Control Unit CU310 - PM340 with CUA31	mm	234.6 (9.23) 175.3 (6.90)	234.6 (9.23) 175.3 (6.90)	234.6 (9.23) 175.3 (6.90)	234.6 (9.23) 175.3 (6.90)	234.6 (9.23) 175.3 (6.90)
Frame size		A	A	A	A	A
Weight, approx.	kg	1.2	1.2	1.2	1.2	1.2

- 1) The input current depends on the motor load and line impedance. The input currents apply for a load with the rated power (based on In) for a line impedance corresponding to uk = 1%.
- 2) Max. motor cable length 50 m (shielded), 100 m (non-shielded), for Power Modules PM340 with integrated line filter to maintain the limit values of EN 61800-3 Category C2.

Table 3-11 Technical data PM340, Part 3

Line voltage 3-ph. 380 V to 480 V AC						
PM340	6SL3210-	1SE16-0UA0	1SE17-7UA0	1SE21-0UA0	1SE21-8AA0	1SE22-5UA0
PM340 with integrated line filter	6SL3210-	1SE16-0AA0	1SE17-7AA0	1SE21-0AA0	1SE21-8UA0	1SE22-5AA0
Rated output current In	A	5.9	7.7	10.2	18	25
Base load current IH	A	5.2	6.8	9.1	14	21
Output current for S6 duty (40%) Is6	A	6.4	8.3	10.8	19.6	27.8
Max. output current Imax	A	11.8	15.4	20.4	26.4	38
Rated power based on In	kW	2.2	3	4	7.5	11
Rated power based on IH	kW	2.2	3	4	5.5	7.5
Rated pulse frequency	kHz	4	4	4	4	4
Efficiency η		0.97	0.97	0.97	0.97	0.97

Line voltage 3-ph. 380 V to 480 V AC						
PM340	6SL3210-	1SE16-0UA0	1SE17-7UA0	1SE21-0UA0	1SE21-8AA0	1SE22-5UA0
PM340 with integrated line filter	6SL3210-	1SE16-0AA0	1SE17-7AA0	1SE21-0AA0	1SE21-8UA0	1SE22-5AA0
Power loss	kW	0.139	0.158	0.183	0.240	0.297
Cooling air requirement	m <sup>3</sup> /s	0.009	0.009	0.009	0.038	0.038
Sound pressure level	dB(A)	< 50	< 50	< 50	< 60	< 60
24 V DC power supply for the Control Unit	A	1.0	1.0	1.0	1.0	1.0
Rated input current <sup>1)</sup> - with line reactor - without line reactor	A	6.1 6.7	8 8.9	10.4 12.4	18.7 23.1	26 32.6
Resistance value of the external braking resistor	Ohm	≥ 160	≥ 160	≥ 160	≥ 56	≥ 56
Max. cable length to braking resistor	m	15	15	15	15	15
Line supply connection U1/L1, V1/L2, W1/L3		Screw terminals for cable cross-sections 1.0 to 6 mm <sup>2</sup>	Screw terminals for cable cross-sections 1.0 to 6 mm <sup>2</sup>	Screw terminals for cable cross-sections 1.0 to 6 mm <sup>2</sup>	Screw terminals for cable cross-sections 2.5 to 10 mm <sup>2</sup>	Screw terminals for cable cross-sections 2.5 to 10 mm <sup>2</sup>
Motor connection U2, V2, W2		Screw terminals for cable cross-sections 1.0 to 6 mm <sup>2</sup>	Screw terminals for cable cross-sections 1.0 to 6 mm <sup>2</sup>	Screw terminals for cable cross-sections 1.0 to 6 mm <sup>2</sup>	Screw terminals for cable cross-sections 2.5 to 10 mm <sup>2</sup>	Screw terminals for cable cross-sections 2.5 to 10 mm <sup>2</sup>
DC link connection, connection for braking resistor DCP/R1, DCN, R2		Screw terminals for cable cross-sections 1.0 to 6 mm <sup>2</sup>	Screw terminals for cable cross-sections 1.0 to 6 mm <sup>2</sup>	Screw terminals for cable cross-sections 1.0 to 6 mm <sup>2</sup>	Screw terminals for cable cross-sections 2.5 to 10 mm <sup>2</sup>	Screw terminals for cable cross-sections 2.5 to 10 mm <sup>2</sup>
PE connection		at the housing with M 5 screw	at the housing with M 5 screw	at the housing with M 5 screw	at the housing with M 5 screw	at the housing with M 5 screw
Max. motor cable length <sup>2)</sup>	m	50 (shielded) 75 (non-shielded)	50 (shielded) 75 (non-shielded)	50 (shielded) 75 (non-shielded)	50 (shielded) 75 (non-shielded)	50 (shielded) 75 (non-shielded)
Degree of protection		IP20 or IPXXB	IP20 or IPXXB	IP20 or IPXXB	IP20 or IPXXB	IP20 or IPXXB
Depth - PM340 with Control Unit CU310 - PM340 with CUA31	mm	254.6 (10.02) 195.3 (8.47)	254.6 (10.02) 195.3 (8.47)	254.6 (10.02) 195.3 (8.47)	274.6 (10.81) 215.3 (8.47)	274.6 (10.81) 215.3 (8.47)
Frame size		B	B	B	C	C
Weight, approx.	kg	4.0	4.0	4.0	6.5	6.5

1) The input current depends on the motor load and line impedance. The input currents apply for a load with the rated power (based on I<sub>n</sub>) for a line impedance corresponding to uk = 1%.

2) Max. motor cable length 50 m (shielded), 100 m (non-shielded), for Power Modules PM340 with integrated line filter to maintain the limit values of EN 61800-3 Category C2.

Power Modules

3.1 Power Modules Blocksize (PM340)

Table 3-12 Technical data PM340, Part 4

Line voltage 3-ph. 380 V to 480 V AC						
PM340	6SL3210-	1SE23-2UA0	1SE23-8UA0	1SE24-5UA0	1SE26-0UA0	1SE27-5UA0
PM340 with integrated line filter	6SL3210-	1SE23-2AA0	1SE23-8AA0	1SE24-5AA0	1SE26-0AA0	1SE27-5AA0
Rated output current $I_n$	A	32	38	45	60	75
Base load current $I_H$	A	27	33	40	48	65
Output current for S6 duty (40%) $I_{S6}$	A	37.1	49	58	78	98
Max. output current $I_{max}$	A	52	64	76	90	124
Rated power based on $I_n$	kW	15	18.5	22	30	37
Rated power based on $I_H$	kW	11	15	18.5	22	30
Rated pulse frequency	kHz	4	4	4	4	4
Efficiency $\eta$		0.97	0.97	0.97	0.97	0.97
Power loss	kW	0.396	0.38	0.51	0.69	0.99
Cooling air requirement	m <sup>3</sup> /s	0.038	0.022	0.022	0.039	0.022
Sound pressure level	dB(A)	< 60	< 60	< 60	< 60	< 60
24 V DC power supply for the Control Unit	A	1.0	1.0	1.0	1.0	1.0
Rated input current <sup>1)</sup> - with line reactor - without line reactor	A	33 39	40 46	47 53	63 72	78 88
Resistance value of the external braking resistor	Ohm	≥ 56	≥ 27	≥ 27	≥ 27	≥ 15
Max. cable length to braking resistor	m	15	15	15	15	15
Line supply connection U1/L1, V1/L2, W1/L3		Screw terminals for cable cross-sections 2.5 to 10 mm <sup>2</sup>	Stud M6, cable cross-section that can be connected 10 to 35 mm <sup>2</sup>	Stud M6, cable cross-section that can be connected 10 to 35 mm <sup>2</sup>	Stud M6, cable cross-section that can be connected 10 to 35 mm <sup>2</sup>	Stud M6, cable cross-section that can be connected 10 to 35 mm <sup>2</sup>
Motor connection U2, V2, W2		Screw terminals for cable cross-sections 2.5 to 10 mm <sup>2</sup>	Stud M6, cable cross-section that can be connected 10 to 35 mm <sup>2</sup>	Stud M6, cable cross-section that can be connected 10 to 35 mm <sup>2</sup>	Stud M6, cable cross-section that can be connected 10 to 35 mm <sup>2</sup>	Stud M6, cable cross-section that can be connected 10 to 35 mm <sup>2</sup>
DC link connection, connection for braking resistor DCP/R1, DCN, R2		Screw terminals for cable cross-sections 2.5 to 10 mm <sup>2</sup>	Stud M6, cable cross-section that can be connected 10 to 35 mm <sup>2</sup>	Stud M6, cable cross-section that can be connected 10 to 35 mm <sup>2</sup>	Stud M6, cable cross-section that can be connected 10 to 35 mm <sup>2</sup>	Stud M6, cable cross-section that can be connected 10 to 35 mm <sup>2</sup>
PE connection		at the housing with M 5 screw	at the housing with M6 screw	at the housing with M6 screw	at the housing with M6 screw	at the housing with M6 screw



Line voltage 3-ph. 380 V to 480 V AC						
PM340	6SL3210-	1SE23-2UA0	1SE23-8UA0	1SE24-5UA0	1SE26-0UA0	1SE27-5UA0
PM340 with integrated line filter	6SL3210-	1SE23-2AA0	1SE23-8AA0	1SE24-5AA0	1SE26-0AA0	1SE27-5AA0
Max. motor cable length <sup>2)</sup>	m	50 (shielded) 75 (non-shielded)	75 (shielded) 100 (non-shielded)	75 (shielded) 100 (non-shielded)	75 (shielded) 100 (non-shielded)	75 (shielded) 100 (non-shielded)
Degree of protection		IP20 or IPXXB	IP20 or IPXXB	IP20 or IPXXB	IP20 or IPXXB	IP20 or IPXXB
Height PM 340 with integrated line filter	mm	333.4 (13.12)	511 (20.11)	511 (20.11)	511 (20.11)	633 (24.92)
Depth - PM340 with Control Unit CU310 - PM340 with CUA31	mm	274.6 (10.81) 215.3 (8.47)	293.1 (11.53) 233.8 (9.20)	293.1 (11.53) 233.8 (9.20)	293.1 (11.53) 233.8 (9.20)	293.1 (11.53) 233.8 (9.20)
Frame size		C	D	D	D	E
Weight, approx. without line filter/ with integrated line filter	kg	6.5 6.5	15.9 19.3	15.9 19.3	15.9 19.3	19.8 27.1

- 1) The input current depends on the motor load and line impedance. The input currents apply for a load with the rated power (based on  $I_n$ ) for a line impedance corresponding to  $u_k = 1\%$ .
- 2) Max. motor cable length 50 m (shielded), 100 m (non-shielded), for Power Modules PM340 with integrated line filter to maintain the limit values of EN 61800-3 Category C2.

Table 3-13 Technical data PM340, Part 5

Line voltage 3-ph. 380 V to 480 V AC					
PM340	6SL3210-	1SE31-0UA0	1SE31-1UA0	1SE31-5UA0	1SE31-8UA0
PM340 with integrated line filter	6SL3210-	1SE31-0AA0	1SE31-1AA0	1SE31-5AA0	1SE31-8AA0
Rated output current $I_n$	A	90	110	145	178
Base load current $I_H$	A	80	95	115	155
Output current for S6 duty (40%) $I_{S6}$	A	117	143	188	231
Max. output current $I_{max}$	A	150	180	220	290
Rated power based on $I_n$	kW	45	55	75	90
Rated power based on $I_H$	kW	37	45	55	75
Rated pulse frequency	kHz	4	4	4	4
Efficiency $\eta$		0.97	0.97	0.97	0.97
Power loss	kW	1.21	1.42	1.93	2.31
Cooling air requirement	m <sup>3</sup> /s	0.039	0.094	0.094	0.117
Sound pressure level	dB(A)	62	< 60	< 60	65
24 V DC power supply for the Control Unit	A	1.0	1.0	1.0	1.0

3.1 Power Modules Blocksize (PM340)

Line voltage 3-ph. 380 V to 480 V AC					
PM340	6SL3210-	1SE31-0UA0	1SE31-1UA0	1SE31-5UA0	1SE31-8UA0
PM340 with integrated line filter	6SL3210-	1SE31-0AA0	1SE31-1AA0	1SE31-5AA0	1SE31-8AA0
Rated input current <sup>1)</sup> - with line reactor - without line reactor	A	94 105	115 129	151 168	186 204
Resistance value of the external braking resistor	Ohm	≥ 15	≥ 8.2	≥ 8.2	≥ 8.2
Max. cable length to braking resistor	m	15	15	15	15
Line supply connection U1/L1, V1/L2, W1/L3		Stud M6, cable cross-section that can be connected 10 to 35 mm <sup>2</sup>	Stud M8, max. cable cross- section that can be connected 1 x 120 mm <sup>2</sup> or 2 x 50 mm <sup>2</sup>	Stud M8, max. cable cross- section that can be connected 1 x 120 mm <sup>2</sup> or 2 x 50 mm <sup>2</sup>	Stud M8, max. cable cross- section that can be connected 1 x 120 mm <sup>2</sup> or 2 x 50 mm <sup>2</sup>
Motor connection U2, V2, W2		Stud M6, cable cross-section that can be connected 10 to 35 mm <sup>2</sup>	Stud M8, max. cable cross- section that can be connected 1 x 120 mm <sup>2</sup> or 2 x 50 mm <sup>2</sup>	Stud M8, max. cable cross- section that can be connected 1 x 120 mm <sup>2</sup> or 2 x 50 mm <sup>2</sup>	Stud M8, max. cable cross- section that can be connected 1 x 120 mm <sup>2</sup> or 2 x 50 mm <sup>2</sup>
DC link connection, connection for braking resistor DCP/R1, DCN, R2		Stud M6, cable cross-section that can be connected 10 to 35 mm <sup>2</sup>	Stud M8, max. cable cross- section that can be connected 1 x 120 mm <sup>2</sup> or 2 x 50 mm <sup>2</sup>	Stud M8, max. cable cross- section that can be connected 1 x 120 mm <sup>2</sup> or 2 x 50 mm <sup>2</sup>	Stud M8, max. cable cross- section that can be connected 1 x 120 mm <sup>2</sup> or 2 x 50 mm <sup>2</sup>
PE connection		at the housing with M6 screw	At the housing with M8 screw	At the housing with M8 screw	At the housing with M8 screw
Max. motor cable length <sup>2)</sup>	m	75 (shielded) 100 (non-shielded)	70 (shielded) 100 (non-shielded)	70 (shielded) 100 (non-shielded)	70 (shielded) 100 (non-shielded)
Degree of protection		IP20 or IPXXB	IP20 or IPXXB	IP20 or IPXXB	IP20 or IPXXB
Height PM 340 with integrated line filter	mm	633 (24.92)	934 (36.77)	934 (36.77)	934 (36.77)
Depth - PM340 with Control Unit CU310 - PM340 with CUA31	mm	293.1 (11.53) 233.8 (9.20)	405.1 (15.94) 345.8 (13.61)	405.1 (15.94) 345.8 (13.61)	405.1 (15.94) 345.8 (13.61)
Frame size		E	F	F	F
Weight, approx. without line filter/ with integrated line filter	kg	19.8 27.1	50.7 66.7	50.7 66.7	50.7 66.7

- 1) The input current depends on the motor load and line impedance. The input currents apply for a load with the rated power (based on In) for a line impedance corresponding to uk = 1%.
- 2) Max. motor cable length 50 m (shielded), 100 m (non-shielded), for Power Modules PM340 with integrated line filter to maintain the limit values of EN 61800-3 Category C2.

Table 3-14 Cooling air requirement

Frame size	Required cooling air quantity	
A	M <sup>3</sup> /h	17.3
B	M <sup>3</sup> /h	86.4
C	M <sup>3</sup> /h	197.6
D	M <sup>3</sup> /h	197.6
E	M <sup>3</sup> /h	396
F	M <sup>3</sup> /h	540

### Interrelationship between the pulse frequency and current de-rating

Table 3-15 Current de-rating depending on the pulse frequency

Order No.	Line voltage	Rated output current	Power (high overload)	Output current in A at a switching frequency of:						
				4 kHz	6 kHz	8 kHz 70%	10 kHz	12 kHz 50%	14 kHz	16 kHz 40%
6SL3210 -		A	[kW]							
1SB11-0UA0	1-ph. 230 V AC	0.9	0.12	0.9	0.7	0.54	0.4	0.3	0.3	0.2
1SB12-3UA0		2.3	0.37	2.3	1.8	1.3	1.1	0.9	0.8	0.6
1SB14-0UA0		3.9	0.75	3.9	3.1	2.3	1.9	1.5	1.3	1.1
1SE11-3UA0	3-ph. 400 V AC	1.3	0.37	1.3	-	0.91	-	0.65	-	0.52
1SE11-7UA0		1.7	0.55	1.7	-	1.19	-	0.85	-	0.68
1SE12-2UA0		2.2	0.75	2.2	-	1.54	-	1.1	-	0.88
1SE13-1UA0		3.1	1.1	3.1	-	2.17	-	1.55	-	1.24
1SE14-1UA0		4.1	1.5	4.1	-	2.87	-	2.05	-	1.64
1SE16-0UA0		5.9	2.2	5.9	-	4.13	-	2.95	-	2.36
1SE17-7UA0		7.7	3	7.7	-	5.39	-	3.85	-	3.08
1SE21-0UA0		10	4	10	-	7	-	5	-	4
1SE21-8UA0		18	5.5	18	-	12.6	-	9	-	7.02
1SE22-5UA0		25	7.5	25	-	17.5	-	12.5	-	10

Order No.	Line voltage	Rated output current	Power (high overload)	Output current in A at a switching frequency of:						
				4 kHz	6 kHz	8 kHz 70%	10 kHz	12 kHz 50%	14 kHz	16 kHz 40%
6SL3210 -		A	[kW]							
1SE23-2UA0		32	15.0	32.0	30.4	28.8	25.6	22.4	19.2	16.0
1SE23-8UA0		38	18.5	38.0	34.2	30.4	26.6	22.8	19.0	15.2
1SE24-5UA0		45	22.0	45.0	40.5	36.0	31.5	27.0	22.5	18.0
1SE26-0UA0		60	30.0	62.0	58.9	55.8	49.6	43.4	37.2	31.0
1SE27-5UA0		75	37.0	75.0	67.5	60.0	52.5	45.0	37.5	30.0
1SE31-0UA0		90	45.0	90.0	76.5	63.0	51.8	40.5	33.8	27.0
1SE31-1UA0		110	55.0	110.0	93.5	77.0	63.3	49.5	41.3	33.0
1SE31-5UA0		145	75.0	145.0	112.4	79.8	68.9	58.0	50.8	43.5
1SE31-8UA0		178	15.0	32.0	30.4	28.8	25.6	22.4	19.2	16.0

Overload capability

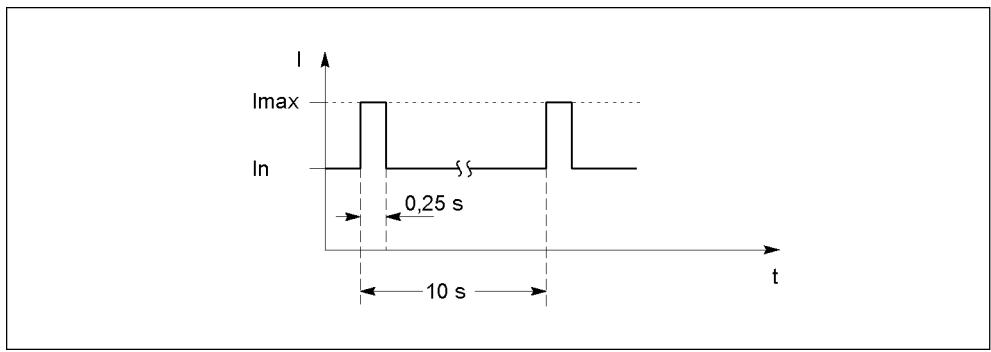

Figure 3-20 Load cycle with pre-load condition

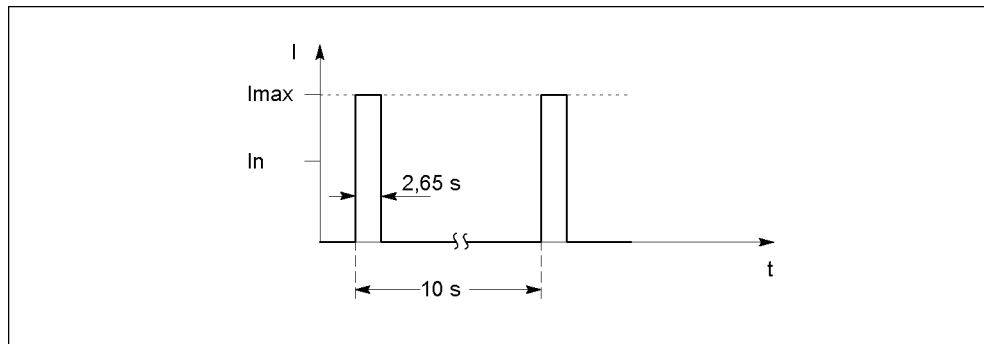

Figure 3-21 Load cycle without pre-load condition

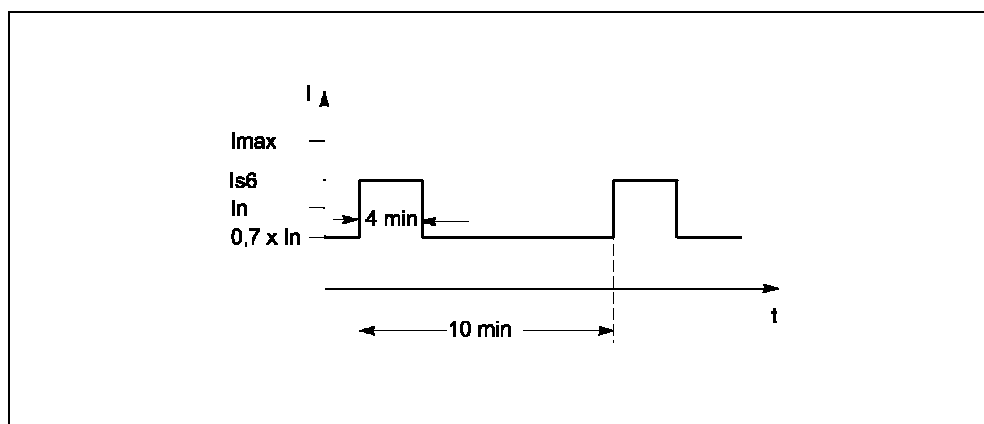

Figure 3-22 S6 load cycle with pre-load condition

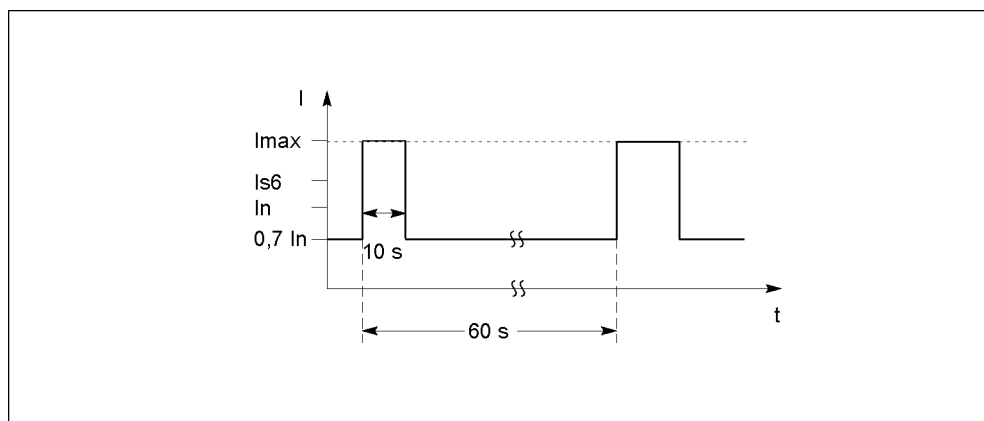

Figure 3-23 S6 load cycle with pre-load condition

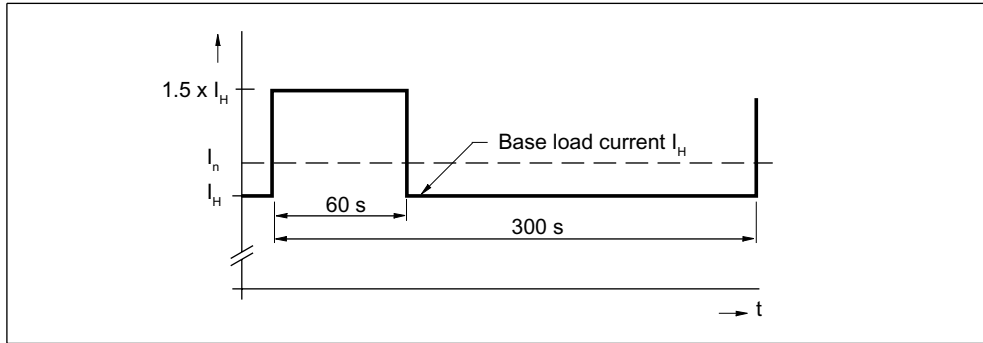

Figure 3-24 Load cycle with 60 s overload with a load cycle period of 300 s

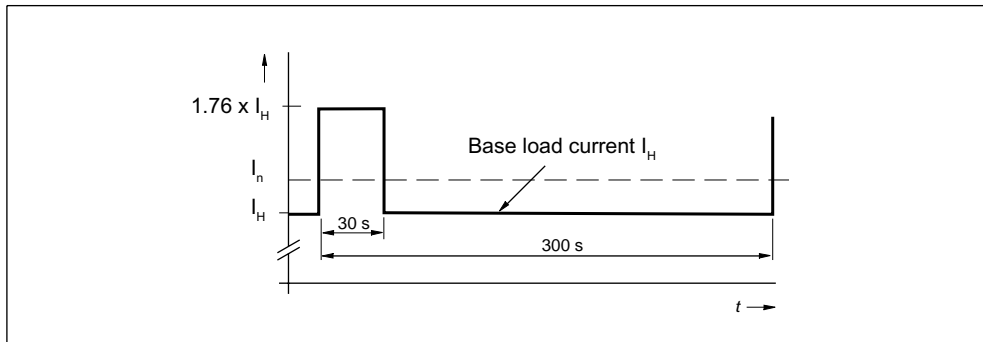

Figure 3-25 Load cycle with 30 s overload with a load cycle period of 300 s

**Derating characteristic for Power Modules in Blocksize format**

Frame sizes A - C

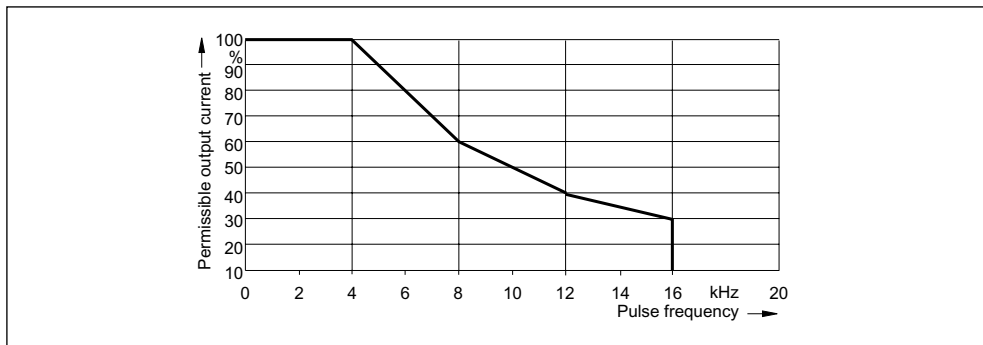

Figure 3-26 Output current as a function of pulse frequency

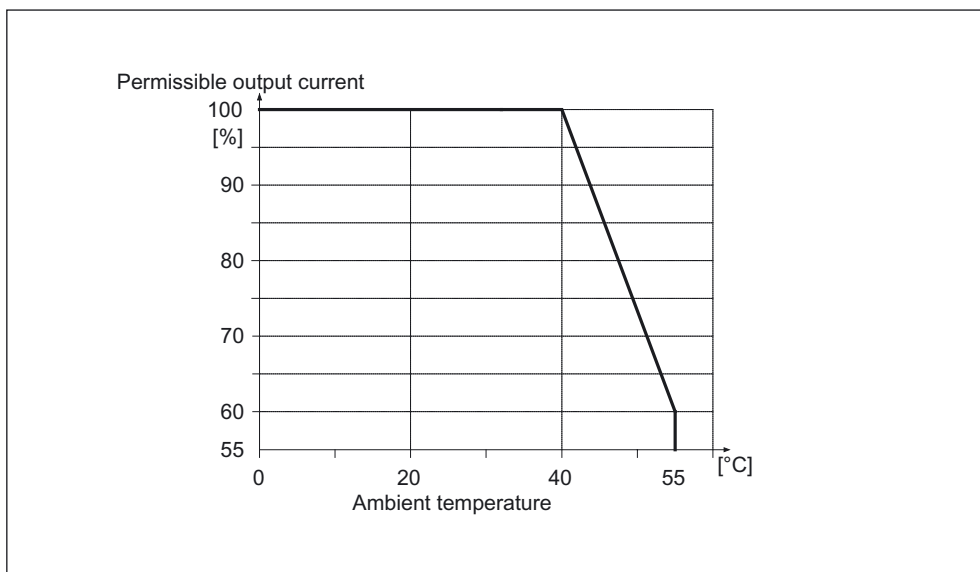

Figure 3-27 Output power as a function of ambient temperature

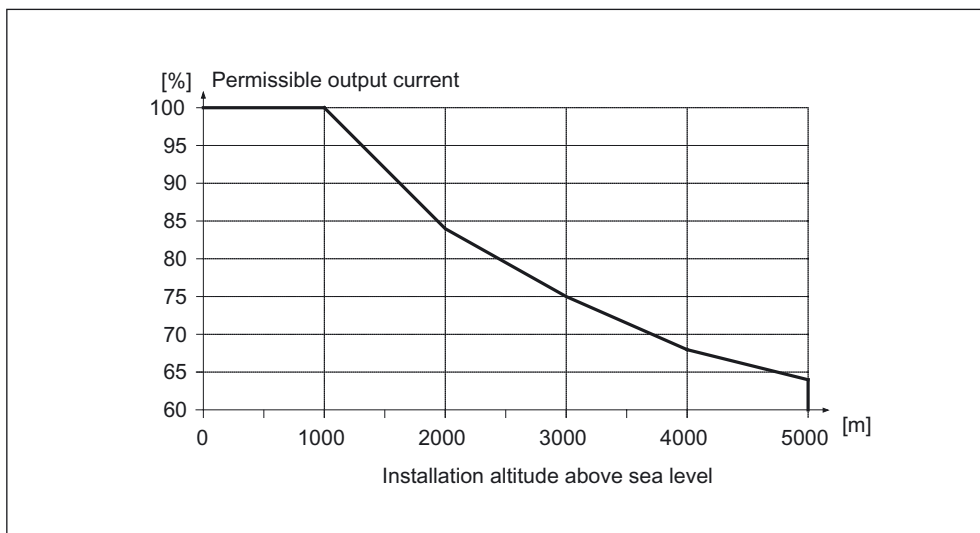

Figure 3-28 Output power as a function of installation altitude

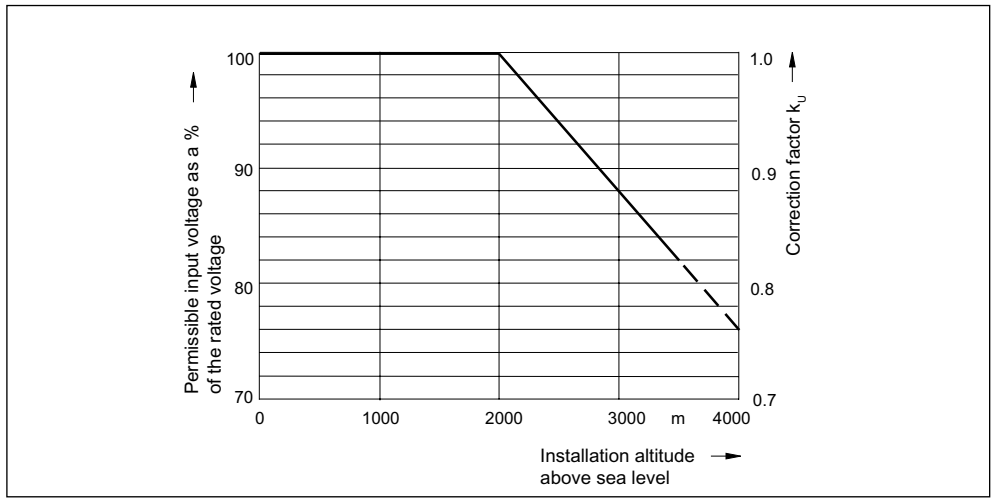

Figure 3-29 Voltage correction factor as a function of installation altitude

### 3.2 Power Modules Chassis

#### 3.2.1 Description

A Power Module is a power unit (frequency inverter) that provides the power supply for the connected motor. A Power Module must be connected to a Control Unit via DRIVE-CLiQ. The open-loop and closed-loop control functions are stored in the Control Unit.

#### Characteristics of Power Modules

- Version from 210 A to 490 A
- Internal air cooling
- Short-circuit/ground-fault-proof
- Electronic type plate
- Operating status and error status displayed using LEDs
- DRIVE-CLiQ interface for communication with the Control Unit and/or other components in the drive line-up
- Integration in system diagnostics



### 3.2.2 Safety information



---

**Danger**

After disconnecting all the supply voltages, a hazardous voltage will be present at all Power Modules for another 5 minutes. Work cannot be carried out until this time has elapsed.

---



---

**Danger**

The DC link discharge voltage hazard warning in the local language must be attached to all of the components.

---



---

**Caution**

The cooling clearances above, below, and in front of the component, which are specified in the dimension drawings, must be observed.

---



---

**Danger**

Cable shields and unused power cable conductors must be connected to PE potential to prevent capacitive cross-talk charges.

Non-observance can cause lethal shock voltages.

---

### 3.2.3 Interface description

#### 3.2.3.1 Overview

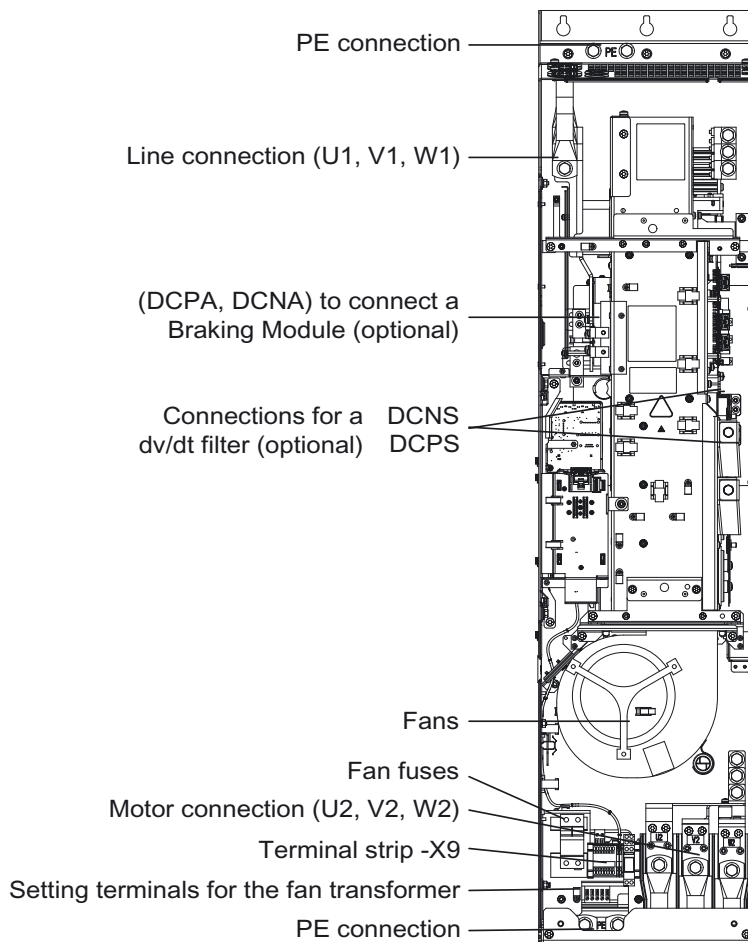

Figure 3-30 Power Module, frame size FX

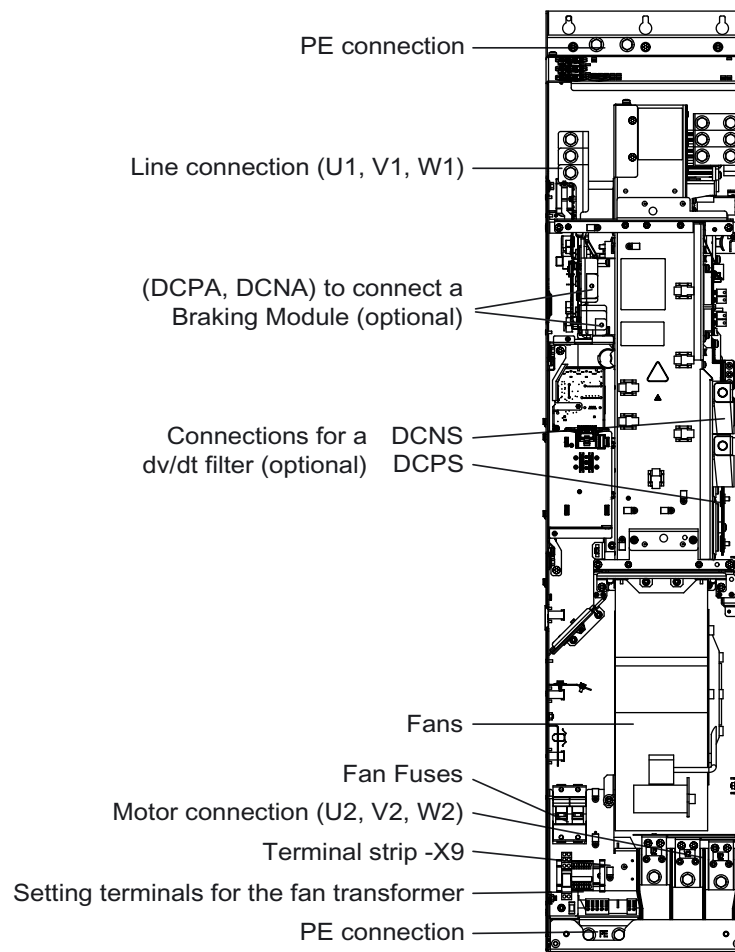

Figure 3-31 Power Module, frame size GX

3.2.3.2 Sample connection

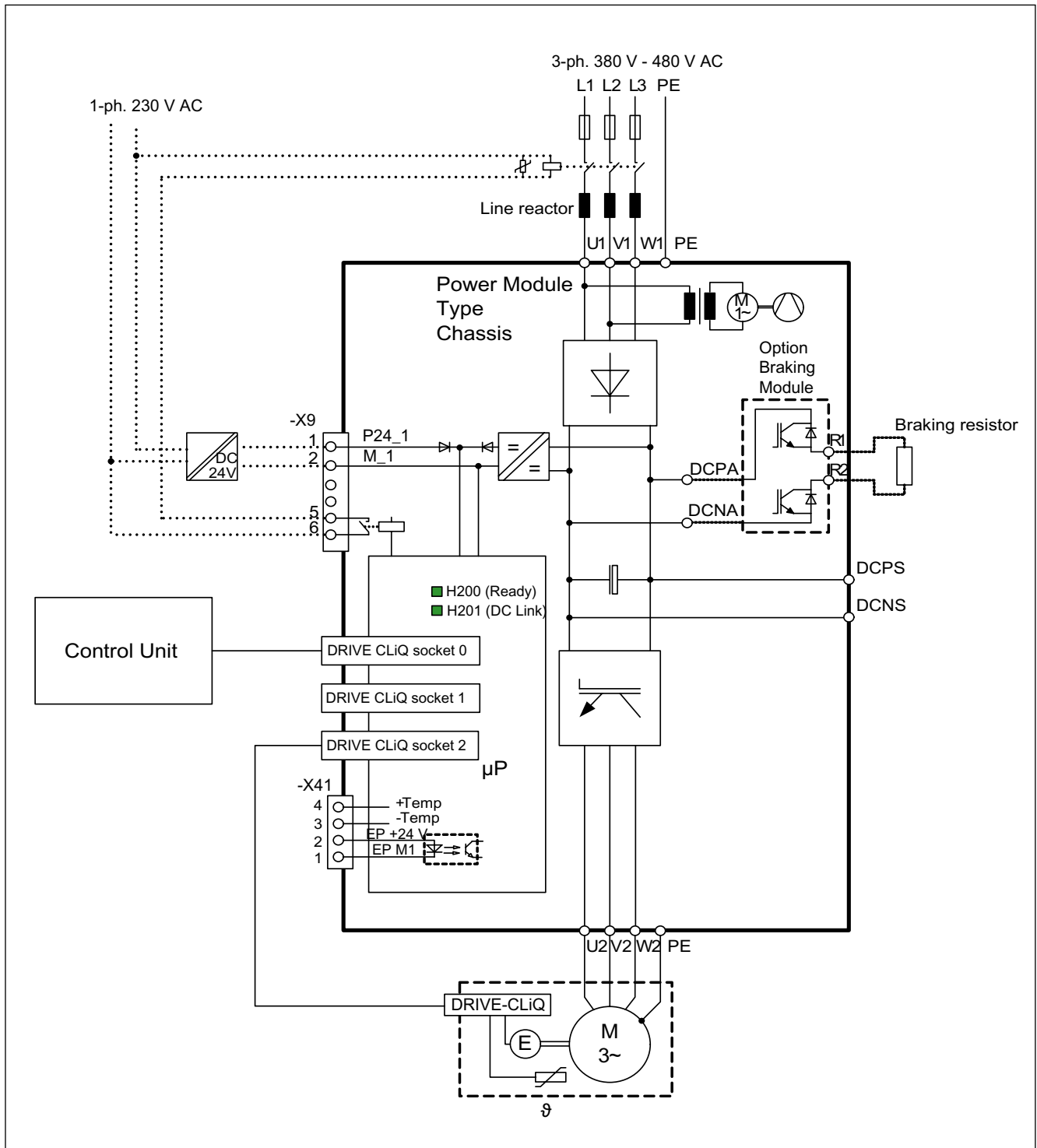
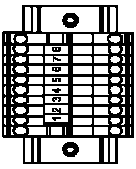

Figure 3-32 Connection example: Power Module Chassis

### 3.2.3.3 Terminal Block X9

Table 3-16 Terminal strip X9

	Terminal	Signal name	Technical specifications
	1	P24V	Voltage: 24 V DC (20.4 V - 28.8 V) Current consumption: max 1.4 A
	2	M	
	3	Reserved, do not use	
	4	Reserved, do not use	
	5	Reserved, do not use	
	6	Reserved, do not use	
	7	EP +24 V (Enable Pulses)	Supply voltage: 24 V DC (20,8 V - 28.8 V) Current consumption: 10 mA Signal propagation times: L->H: 100 µs H->L: 1000 µs
	8	EP M1 (Enable Pulses)	

#### Note

For operation, 24 V DC must be connected to terminal 7 and ground to terminal 8. Upon removal, pulse inhibit is activated.

### 3.2.3.4 DCPS, DCNS connection for a dv/dt filter

Table 3-17 DCPS, DCNS

Frame size	Cross-section that can be connected	Terminal screw
FX	1 x 35 mm <sup>2</sup>	M8
GX	1 x 70 mm <sup>2</sup>	M8

The connecting cable is fed-out downwards through the Power Module.

3.2.3.5 X41 EP terminal / temperature sensor connection

Table 3-18 Terminal strip X41

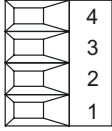
	Terminal	Function	Technical specifications
	4	+Temp	Temperature sensor connection KTY84-1C130
	3	-Temp	
	2	are assigned	
	1	are assigned	

Max. cross-section that can be connected: 1.5 mm<sup>2</sup> (AWG 14)

**Notice**

The KTY temperature sensor must be connected with the correct polarity.

**Note**

The temperature sensor connection can be used for motors that are equipped with a KTY84-1C130 measurement sensor in the stator windings.

3.2.3.6 DRIVE-CLiQ Interface X400-X402

Table 3-19 DRIVE-CLiQ Interface X400-X402

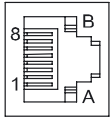
	Pin	Name	Technical specifications
	1	TXP	Transmit data +
	2	TXN	Transmit data -
	3	RXP	Receive data +
	4	Reserved, do not use	
	5	Reserved, do not use	
	6	RXN	Receive data -
	7	Reserved, do not use	
	8	Reserved, do not use	
	A	+ (24 V)	Power supply
	B	GND (0 V)	Electronic ground

### 3.2.3.7 Meaning of the LEDs on the Power Module

Table 3-20 Meaning of the LEDs on the Power Module

LED state		Description
H200	H201	
Off	Off	The electronics power supply is missing or lies outside permissible tolerance range.
Green	Off	The component is ready for operation and cyclic DRIVE-CLiQ communication is taking place.
	Orange	The component is ready for operation and cyclic DRIVE-CLiQ communication is taking place. The DC link voltage is present.
	Red	The component is ready for operation and cyclic DRIVE-CLiQ communication is taking place. The DC link voltage is too high.
Orange	Orange	DRIVE-CLiQ communication is being established.
Red	---	At least one fault is present in this component.
Flashing light 2 Hz: Green Red	---	Firmware is being downloaded.
Flashing light 2 Hz: Green Orange or Red Orange	---	Identifying whether the component is activated using the LED (p0124) Note: Both possibilities depend on the LED status when activated using p0124 = 1.



#### Warning

Independent of the state of LED "H201", hazardous DC link voltages can always be available.

The warning information on the components must be carefully observed!

#### Cause and rectification of faults

The following reference contains information about the cause of the faults and how they can be resolved:

Reference: /IH1/ SINAMICS S120 Commissioning Manual.

### 3.2.4 Dimension drawings

#### Dimension drawing frame size FX

The cooling clearances to be maintained are indicated by the dotted line.

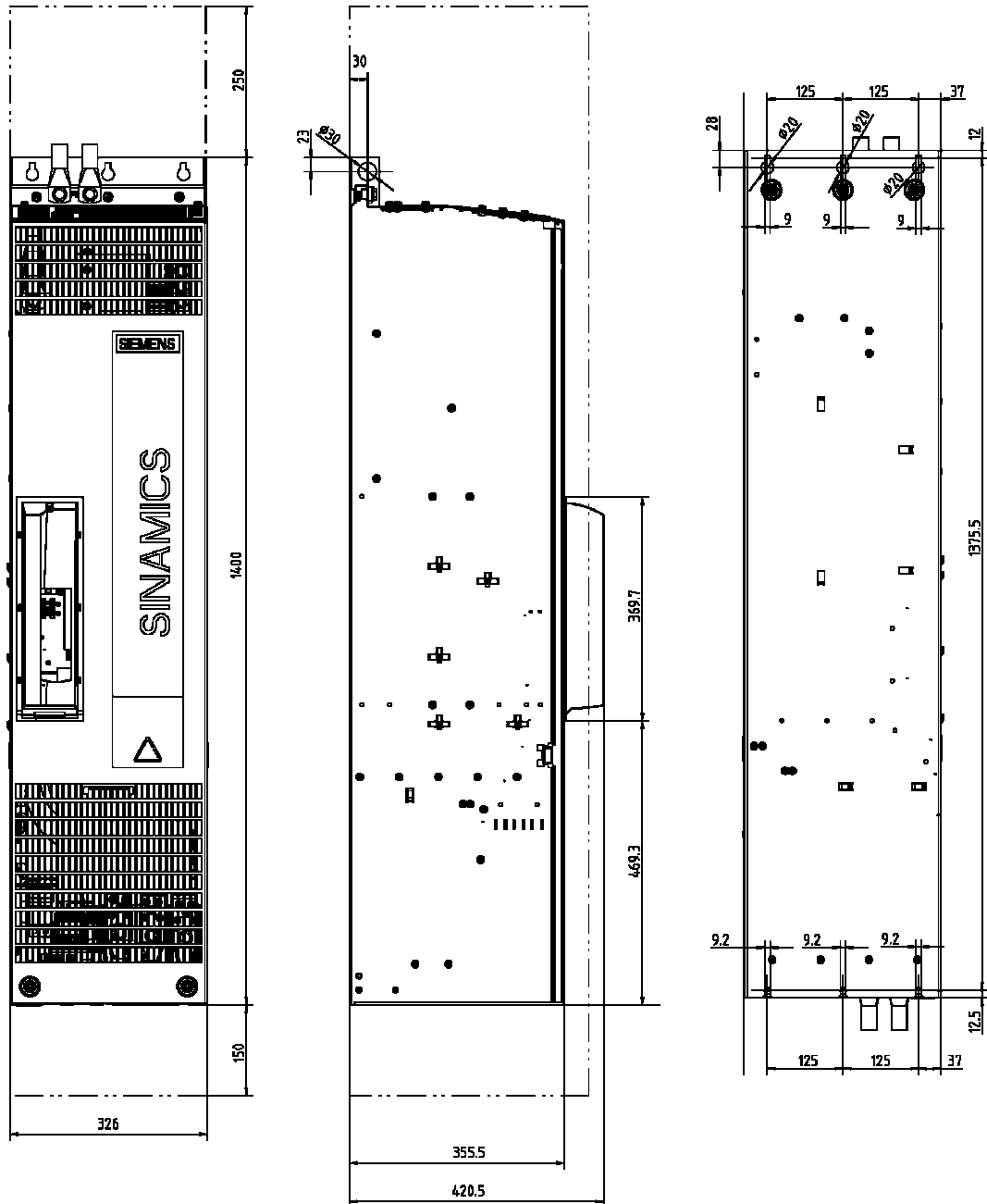

Figure 3-33 Dimension drawing Power Module, frame size FX



Dimension drawing frame size GX

The cooling clearances to be maintained are indicated by the dotted line.

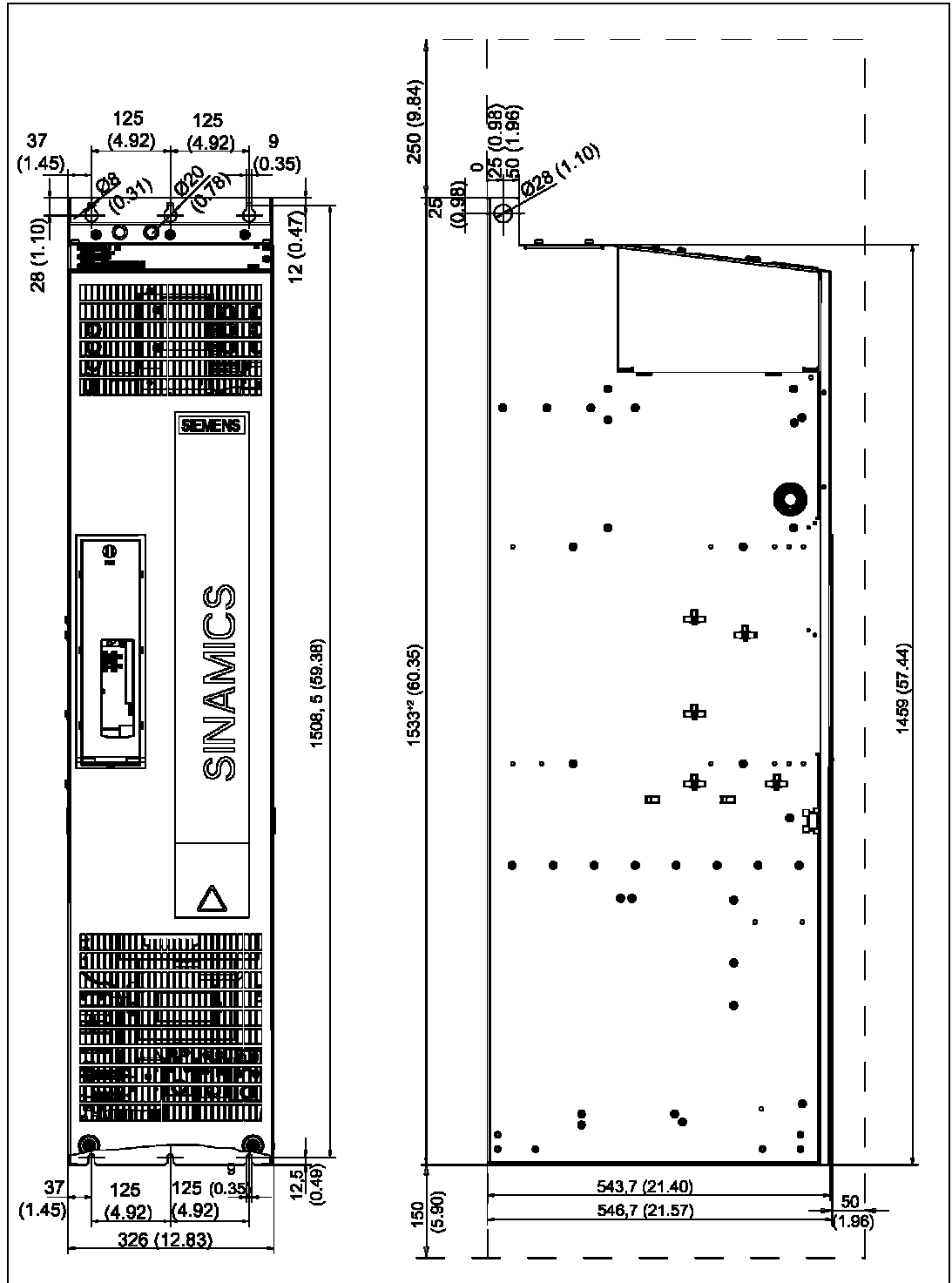

Figure 3-34 Dimension drawing Power Module, frame size GX

### 3.2.5 Mounting the CU310 in the Power Module Chassis

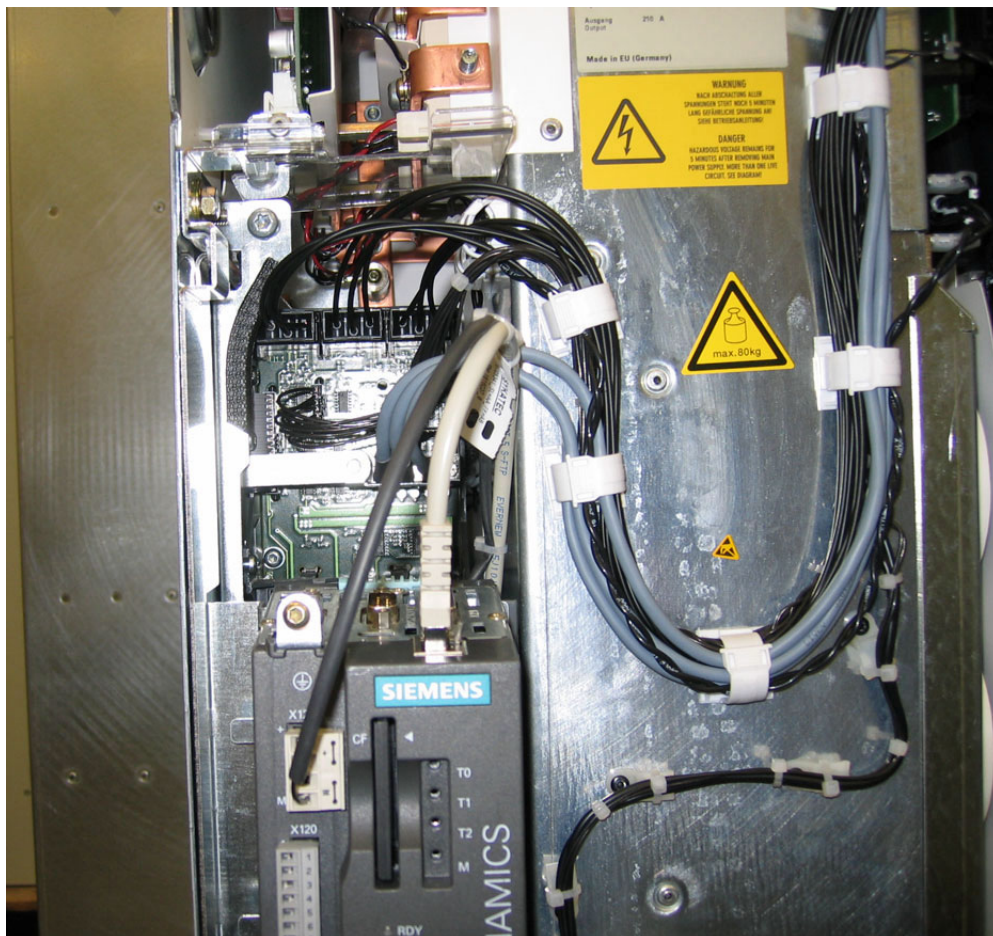

Figure 3-35 Mounting the CU310 in the Power Module Chassis, frame size FX

The DRIVE-CLiQ cable and the cable for the 24 V power supply must be correctly routed so that the front flap can close.

### 3.2.6 Electrical connection

#### Adjusting the fan voltage (-T10)

The power supply for the device fans (1-ph. 230 V AC) in the Power Module (-T10) is taken from the line supply using transformers. The locations of the transformers are indicated in the interface descriptions.

The transformers are fitted with primary taps so that they can be fine-tuned to the line supply voltage. When delivered, the taps are always set to the highest level. With a low supply voltage, the appropriate transformer tap must be activated.

The connections at the setting terminals must be connected to "0" and the line supply voltage.

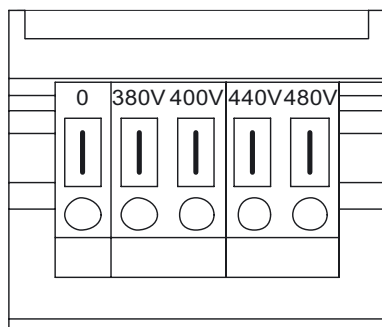

Figure 3-36 Setting terminals for the fan transformers

The supply voltage assignments for making the appropriate setting on the fan transformer are indicated in the following table (factory presetting): 480 V/0 V

---

#### Caution

If the terminals are not changed-over to reflect the actual line supply voltage:

- The required cooling level will not provided (risk of overheating)
  - The fan fuses may blow (overload)
- 

Table 3-21 Assignment of the existing line supply voltage for setting at the fan transformer

Line supply voltage	Tap at the fan transformer (-T10)
380 V ± 10 %	380 V
400 V ± 10 %	400 V
440 V ± 10 %	440 V
480 V ± 10 %	480 V

## 3.2.7 Technical data

Table 3-22 Technical data, Power Modules Chassis

Line supply voltage 3-ph. 380 V to 480 V AC $\pm 10\%$ ( $-15\% < 1\text{ min}$ )						
Order No.	6SL3310-	1TE32-1AA0	1TE32-6AA0	1TE33-1AA0	1TE33-8AA0	1TE35-0AA0
Rated output current $I_n$	A	210	260	310	380	490
Base load current $I_H$	A	180	233	277	340	438
Output current for S6 duty (40%) $I_{S6}$	A	230	285	340	430	540
Max. output current $I_{max}$	A	307	375	453	555	715
Supply voltages						
Electronics power supply	$V_{DC}$	24 (20,4 - 28,8)				
Overvoltage trip	$V_{DC}$	$820 \pm 2\%$				
Undervoltage trip	$V_{DC}$	424				
Rated power based on $I_n$	kW	110	132	160	200	250
Rated power based on $I_H$	kW	90	110	132	160	200
Max. rated pulse frequency without derating	kHz	2	2	2	2	2
Max. rated pulse frequency with derating	kHz	8	8	8	8	8
Efficiency $\eta$		0.986	0.986	0.986	0.986	0.986
Power loss	kW	2.46	3.27	4.0	4.54	5.78
Cooling air requirement	m <sup>3</sup> /s	0.17	0.23	0.36	0.36	0.36
Sound pressure level at 50/60 Hz	dB(A)	66 / 67	68 / 72	68 / 72	68 / 72	68 / 72
Rated input current	A	218	270	322	395	510
Electronics current drain (24 V DC)	A	0.8	0.8	0.9	0.9	0.9
Line supply connection U1, V1, W1		Flat connector for M10 cable lug, max. connection cross section 2 x 185 mm <sup>2</sup>				
Motor connection U2, V2, W2		Flat connector for M10 cable lug, max. connection cross section 2 x 185 mm <sup>2</sup>				
DC link connections DCPA, DCNA, (option Braking Module)		Flat connector for M8 cable lug, connection cross section 1 x 35 mm <sup>2</sup>	Flat connector for M8 cable lug, connection cross section 1 x 35 mm <sup>2</sup>	Flat connector for M8 cable lug, connection cross section 1 x 50 mm <sup>2</sup>	Flat connector for M8 cable lug, connection cross section 1 x 50 mm <sup>2</sup>	Flat connector for M8 cable lug, connection cross section 1 x 50 mm <sup>2</sup>
DC link connections DCPS, DCNS (option dv/dt filter)		Flat connector for M8 cable lug, connection cross section 1 x 35 mm <sup>2</sup>	Flat connector for M8 cable lug, connection cross section 1 x 35 mm <sup>2</sup>	Flat connector for M8 cable lug, connection cross section 1 x 70 mm <sup>2</sup>	Flat connector for M8 cable lug, connection cross section 1 x 70 mm <sup>2</sup>	Flat connector for M8 cable lug, connection cross section 1 x 70 mm <sup>2</sup>

Line supply voltage 3-ph. 380 V to 480 V AC $\pm$ 10 % (-15 % < 1 min)						
Order No.	6SL3310-	1TE32-1AA0	1TE32-6AA0	1TE33-1AA0	1TE33-8AA0	1TE35-0AA0
PE connection		Flat connector for M10 cable lug, max. connection cross section 2 x 185 mm <sup>2</sup>				
Max. motor cable length <sup>1)</sup>	m	300 (shielded) 450 (non-shielded)				
Max. ambient temperature without derating	°C	40	40	40	40	40
with derating	°C	55	55	55	55	55
Degree of protection		IP 20 or IPXXB	IP 20 or IPXXB	IP 20 or IPXXB	IP 20 or IPXXB	IP 20 or IPXXB
Width	mm	326	326	326	326	326
Height	mm	1400	1400	1533	1533	1533
Depth	mm	356	356	545	545	545
Frame size		FX	FX	GX	GX	GX
Weight	kg	104	104	162	162	162

<sup>1)</sup> Max. motor cable length 100 m (shielded) in conjunction with a line filter to maintain the EMC limit values of EN 61800-3 Category C2.

### 3.2.7.1 Characteristics

#### Overload capability

The Power Modules are equipped with an overload reserve e.g. to handle breakaway torques.

In drives with overload requirements, the appropriate base load current must, therefore, be used as a basis for the required load.

The criterion for overload is that the drive is operated with its base load current before and after the overload occurs (a load duration of 300 s is used as a basis here).

#### Low overload

The base load current for low overload  $I_L$  is based on a load duty cycle of 110% for 60 s or 150% for 10 s with a load duty duration of 300 s.

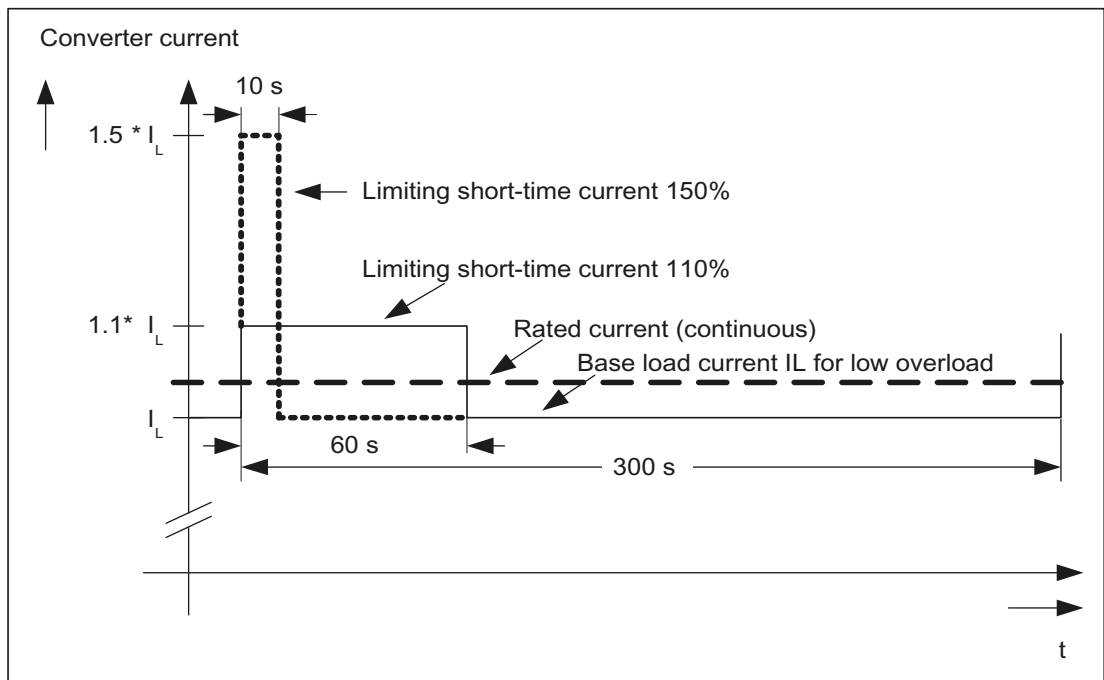

Figure 3-37 Low overload

## High overload

The base load current for high overload  $I_H$  is based on a load duty cycle of 150% for 60 s or 160% for 10 s with a load duty duration of 300 s.

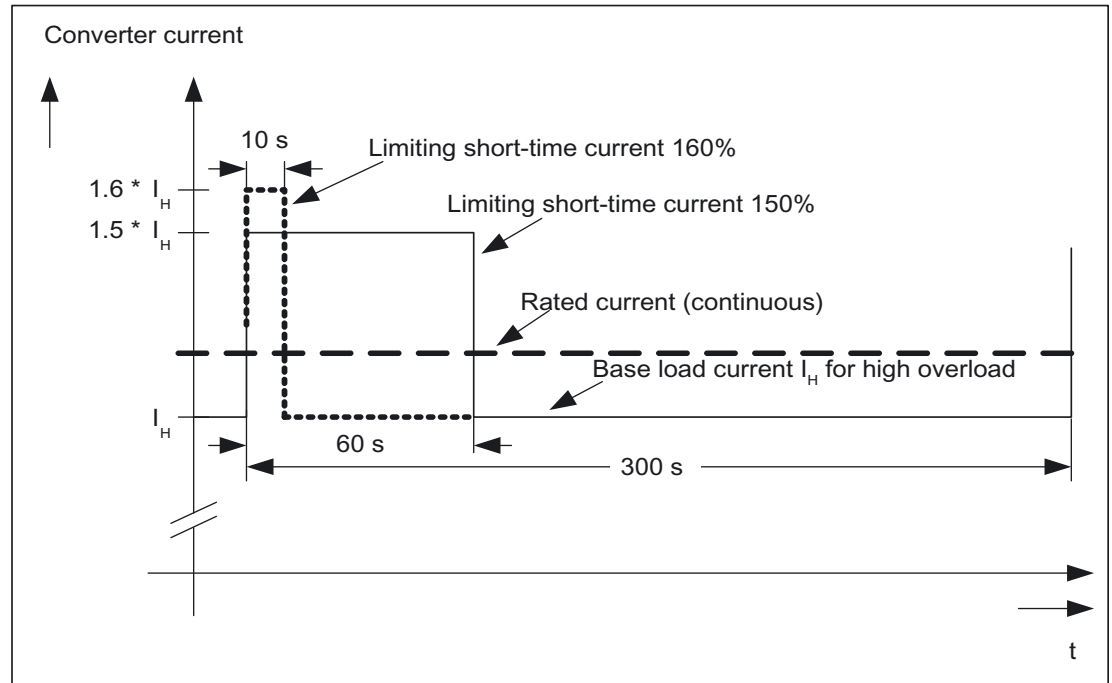

Figure 3-38 High overload

### 3.2.7.2 Current de-rating as a function of the pulse frequency

When the pulse frequency is increased, the derating factor of the output current must be taken into account.

This derating factor must be applied to the currents specified in the technical data.

Table 3-23 Derating factor of the output current as a function of the pulse frequency

Order No. 6SL3310-...	Output current for a pulse frequency of 2 kHz [A]	Permissible output current for a pulse frequency of 2.5 kHz as a % of $I_n$	Derating factor for a pulse frequency of 4 kHz	Derating factor for a pulse frequency of 8 kHz
1TE32-1AA0	210	95 %	82 %	50 %
1TE32-6AA0	260	95 %	83 %	50 %
1TE33-1AA0	310	97 %	88 %	50 %
1TE33-8AA0	380	96 %	87 %	50 %
1TE35-0AA0	490	94 %	78 %	50 %

**Maximum output frequencies achieved by increasing the pulse frequency**

By multiplying the rated pulse frequency with a multiple integer, the following output frequencies can be achieved taking into account the derating factors:

Table 3-24 Maximum output frequencies achieved by increasing the pulse frequency

Pulse frequency [kHz]	Maximum output frequency [Hz]
2	160
4	320 <sup>1</sup>
8	640 <sup>1</sup>

<sup>1</sup> Due to the closed-loop control, the maximum output frequency is limited to 300 Hz.

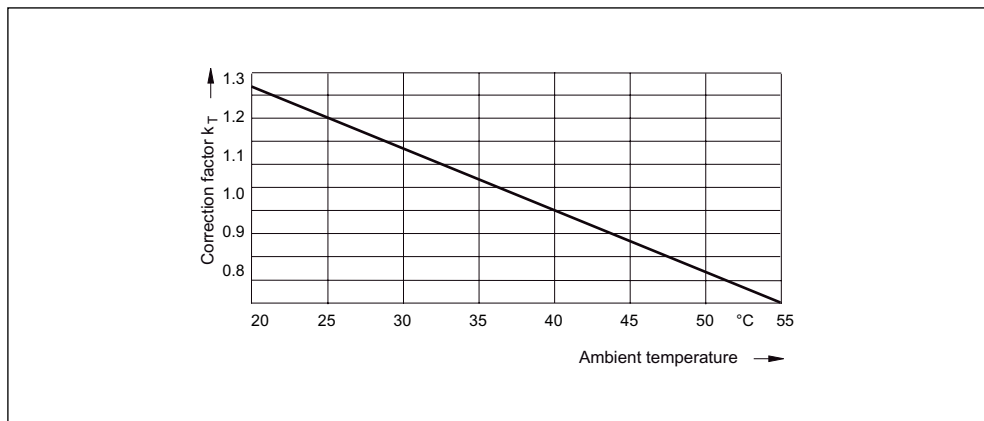

Figure 3-39 Current correction factor as a function of ambient temperature

Note: A factor  $k_T > 1.0$  is only to be taken into account in conjunction with the current derating factor depending on the installation altitude.

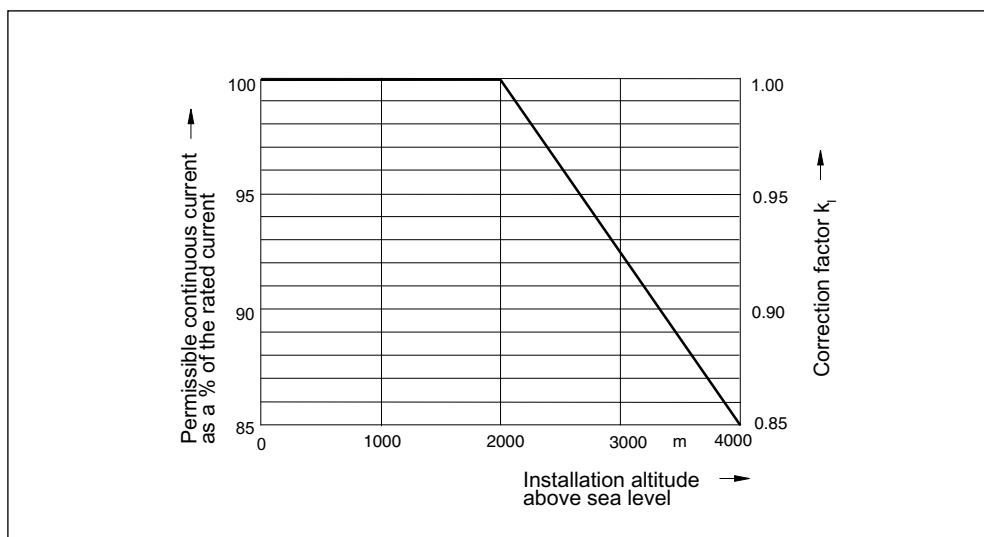

Figure 3-40 Current correction factor as a function of installation altitude



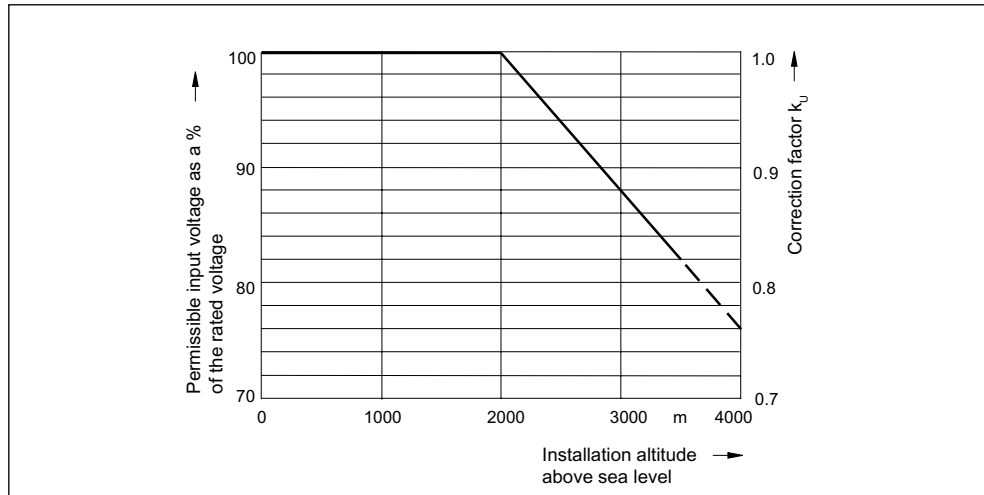

Figure 3-41 Voltage correction factor as a function of installation altitude



## DC link components

### 4.1 Blocksize

#### 4.1.1 Braking resistors

##### 4.1.1.1 Description

The PM340 Power Modules cannot regenerate into the line supply. For the regenerative operation, e.g. the braking of a rotating mass, a braking resistor must be connected to convert the resulting energy into heat.

The braking resistor is connected at terminals DCP/R1 and R2.

The braking resistors can be installed at the side next to the PM340 Power Modules. The braking resistors for A and B frame sizes are designed as sub-chassis components. If the PM340 Power Modules of the A or B frame sizes are operated without line reactor, the braking resistors can also be installed under the Power Modules.

The braking resistors for the Power Modules of the C to F frame sizes should be placed outside the switchgear cabinet or outside the switchgear room in order to conduct the resulting heat loss away from the Power Modules. This reduces the level of air conditioning required.

A temperature protection switch monitors the braking resistor for overtemperature and issues a signal on a floating contact if the limit value is exceeded.

##### 4.1.1.2 Safety information



---

#### Caution

The surface temperature of the braking resistors may exceed 80 °C.

---

### Protecting the resistance

The power supply to the Power Modules must be established through a contactor which can then shut down the power supply when the resistor overheats.

A temperature protection switch handles the protective function (this is supplied with each break resistor). This is connected in series with the coil feeder cable for the main contactor.

The contacts of the temperature protection switch close again as soon as the resistor temperature has fallen below the selected value.

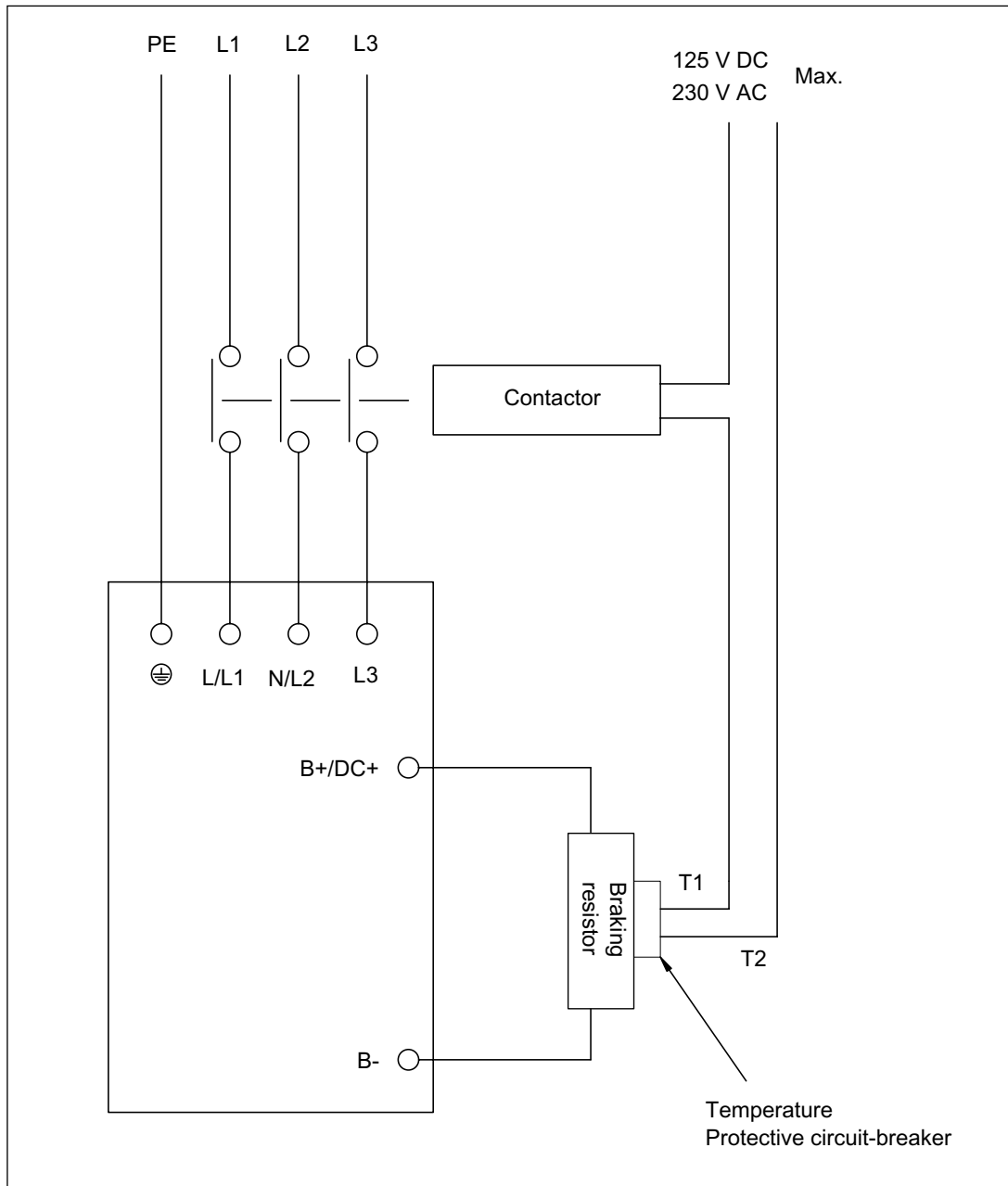

Figure 4-1 Connection example: Braking resistor

### 4.1.1.3 Dimension drawings

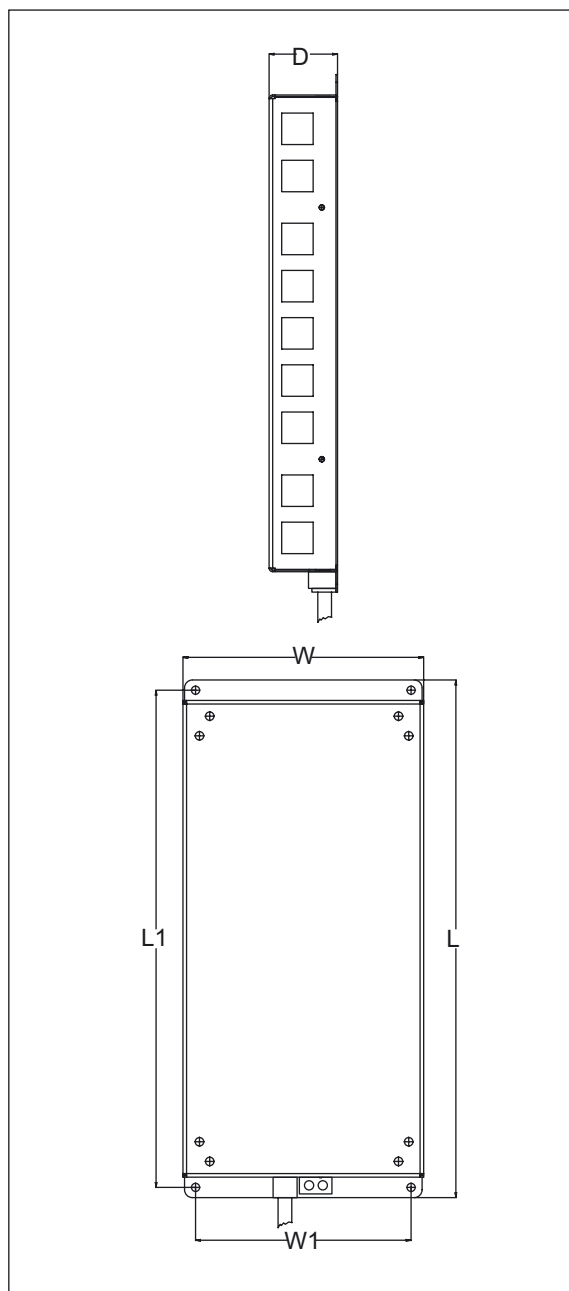

Figure 4-2 Dimension drawing: Braking resistor, frame sizes A and B

4.1 Blocksize

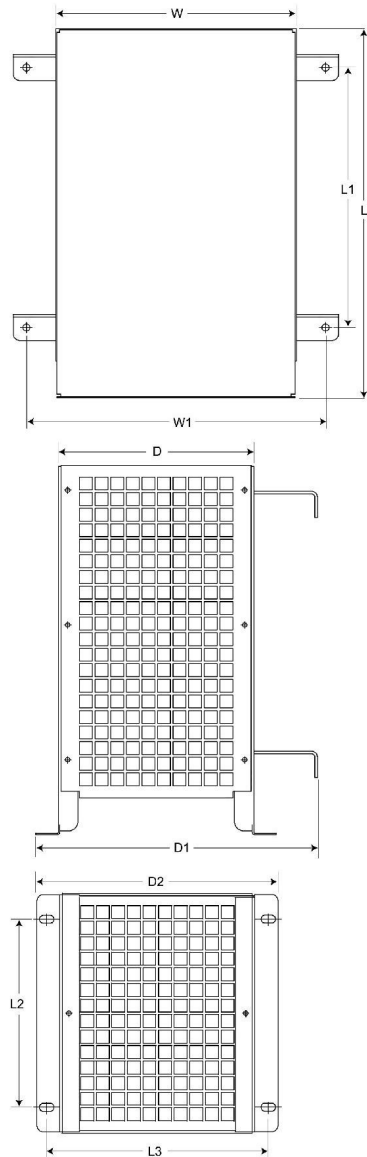

Figure 4-3 Dimension drawing: Braking resistors, frame sizes C, D, E, F

Table 4-1 Dimension data: Braking resistor, all data in mm and (inches), Part 1

Order No. 6SE6400-	4BC05-0AA0	4BD11-0AA0	4BD12-0BA0	4BD16-5CA0
Frame size	A	A	B	C
L	230 (9.05)	230 (9.05)	239 (9.40)	285 (11.22)
L1	217 (8.54)	217 (8.54)	226 (8.89)	200 (7.87)
L2	-	-	-	145 (5.70)
L3	-	-	-	170 (6.69)
D	43.5 (1.71)	43.5 (1.71)	43.5 (1.71)	150 (5.90)
D1	-	-	-	217 (8.54)

Order No. 6SE6400-	4BC05-0AA0	4BD11-0AA0	4BD12-0BA0	4BD16-5CA0
Frame size	A	A	B	C
D2	-	-	-	185 (7.28)
W	72 (2.83)	72 (2.83)	149 (5.86)	185 (7.28)
W1	56 (2.20)	56 (2.20)	138 (5.43)	230 (9.05)

Table 4-2 Dimension data: Braking resistor, all data in mm and (inches), Part 2

Order No. 6SE6400-	4BD21-2DA0	4BD22-2EA0	4BD24-0FA0
Frame size	D	E	F
L	515 (20.27)	645 (25.39)	650 (25.59)
L1	350 (13.77)	480 (18.89)	510 (20.07)
L2	205 (8.07)	205 (8.07)	270 (10.62)
L3	195 (7.67)	195 (7.67)	335 (13.18)
D	175 (6.88)	175 (6.88)	315 (12.40)
D1	242 (9.52)	242 (9.52)	382 (15.03)
D2	210 (8.26)	210 (8.26)	382 (15.03)
W	270 (10.62)	270 (10.62)	400 (15.74)
W1	315 (12.40)	315 (12.40)	435 (17.12)

#### 4.1.1.4 Mounting

The braking resistor is connected at terminals DCP/R1 and R2.

The braking resistors can be installed at the side next to the PM340 Power Modules. The braking resistors for A and B frame sizes are designed as sub-chassis components. If the PM340 Power Modules of the A or B frame sizes are operated without line reactor, the braking resistors can also be installed under the Power Modules.

The braking resistor is positioned outside the cabinet or switchgear room. This enables the resulting heat loss around the Power Modules / Motor Modules to be dissipated, This reduces the level of air conditioning required.

## 4.1.1.5 Technical data

Table 4-3 Technical data, braking resistors, Part 1

Order No.		6SE6400-4BC05-0AA0	6SE6400-4BD11-0AA0	6SL3201-0BE12-0AA0	6SE6400-4BD16-5CA0
Resistance	Ohm	180	390	160	56
Rated power $P_{DB}$	kW	0.05	0.1	0.2	0.65
Peak power $P_{max}$	kW	1	1.7	4.0	13
Load duration for peak power $T_a$	s	27.6	13.8	12.6	13.1
Period duration of braking duty cycle $t$	s	276	276	252	262
Degree of protection		IP20 or IPXXB	IP20 or IPXXB	IP20 or IPXXB	IP20 or IPXXB
Power Connections		Cable 3 x 2.5 mm <sup>2</sup> shielded, length 0.4 m	Cable 3 x 2.5 mm <sup>2</sup> shielded, length 0.5 m	Cable 3 x 2.5 mm <sup>2</sup> shielded, length 0.5 m	Cable 3 x 2.5 mm <sup>2</sup> shielded, length 0.9 m
Thermoswitch (NC contact) maximum contact load connecting cable		250 V <sub>AC</sub> / 2.5 A	250 V <sub>AC</sub> / 2.5 A	250 V <sub>AC</sub> / 2.5 A	250 V <sub>AC</sub> / 2.5 A
Weight	kg	1.0	1.0	1.6	3.8

Table 4-4 Technical data, braking resistors, Part 2

Order No.		6SE6400-4BD21-2DA0	4BD22-2EA0	4BD24-0FA0
Resistance	Ohm	27	15	8.2
Rated power $P_{DB}$	kW	1.2	2.2	4.0
Peak power $P_{max}$	kW	24	44	80
Load duration for peak power $T_a$	s	13.6	14.5	13.1
Period duration of braking duty cycle $t$	s	271	290	252
Degree of protection		IP20 or IPXXB	IP20 or IPXXB	IP20 or IPXXB
Power Connections		M6 studs	M6 studs	M6 studs
Thermoswitch (NC contact) maximum contact load connecting cable		250 V <sub>AC</sub> / 2.5 A	250 V <sub>AC</sub> / 2.5 A	250 V <sub>AC</sub> / 0.2 A
Weight	kg	7.4	10.6	16.7



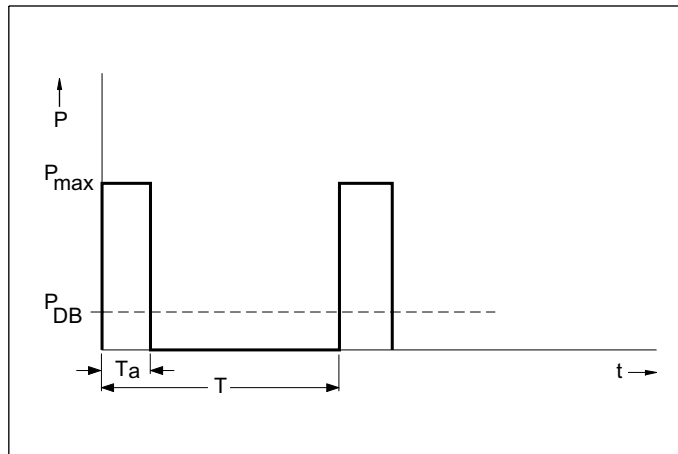

Figure 4-4 Load diagram for the braking resistor, Blocksize format

$T$  [s] period duration of braking duty cycle

$T_a$  [s] load duration for peak power

$P_{DB}$  [W] rated power of the braking resistor

$P_{max}$  [W] peak braking power of the braking resistor

## 4.2 Chassis

### 4.2.1 Braking Modules

#### 4.2.1.1 Description

A Braking Module (and an external braking resistor) is required in certain cases when the drive is to be braked or brought to a standstill (e.g. EMERGENCY SWITCHING-OFF Category 1). The Braking Module contains the power electronics and the associated control. The supply voltage for the electronics is taken from the DC link.

During operation, the DC link energy is converted to heat loss in an external braking resistor.

A mounting slot is provided in the Power Module.

#### Design

The Braking Module in chassis format is installed in a slot within the Power Module and force-cooled by its fan. The Braking Module is connected to the DC link by means of flexible cables, which are supplied as standard.

The Braking Module has as standard, the following interfaces:

- The DC link is connected through flexible cables
- Connecting terminal for external braking resistor
- 1 digital input (inhibit Braking Module with high signal/acknowledge error with negative edge high low)
- 1 digital output (Braking Module defective)

#### 4.2.1.2 Safety information



**Danger**

After disconnecting all the supply voltages, a hazardous voltage will be present in all components for another 5 minutes. Work may not be carried out on the components until after this time has elapsed.

Before starting work, you should also measure the voltage after the 5 minutes have elapsed! The voltage can be measured on DC link terminals DCP and DCN.

---



**Danger**

The DC link discharge voltage hazard warning in the local language must be attached to all of the components.

---



**Danger**

The connection to the braking resistors must be short-circuit/ground-fault proof.

---



**Warning**

If braking resistors are used that have not been released by SIEMENS for SINAMICS, then the braking resistors could be destroyed.

---

4.2.1.3 Braking Module for frame size FX

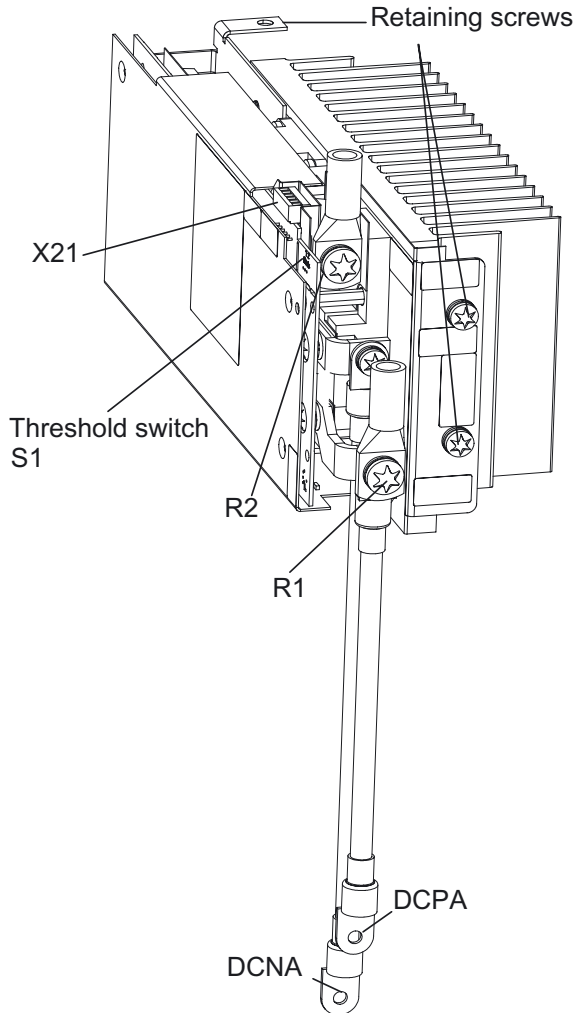

Figure 4-5 Braking Module for Power Module, frame size FX

#### 4.2.1.4 Braking Module for type GX

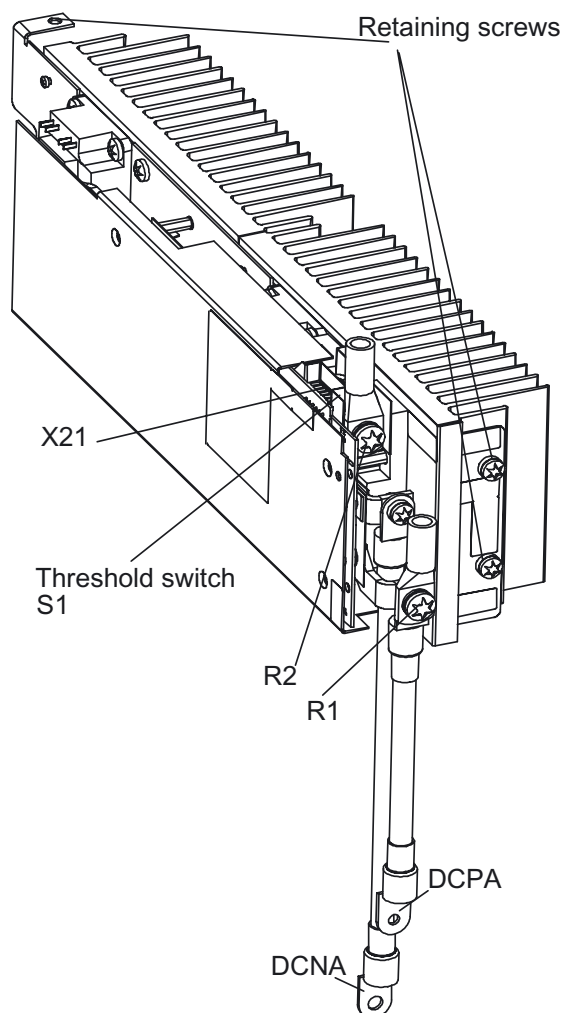

Figure 4-6 Braking Module for Power Module, frame size GX

4.2.1.5 Sample connection

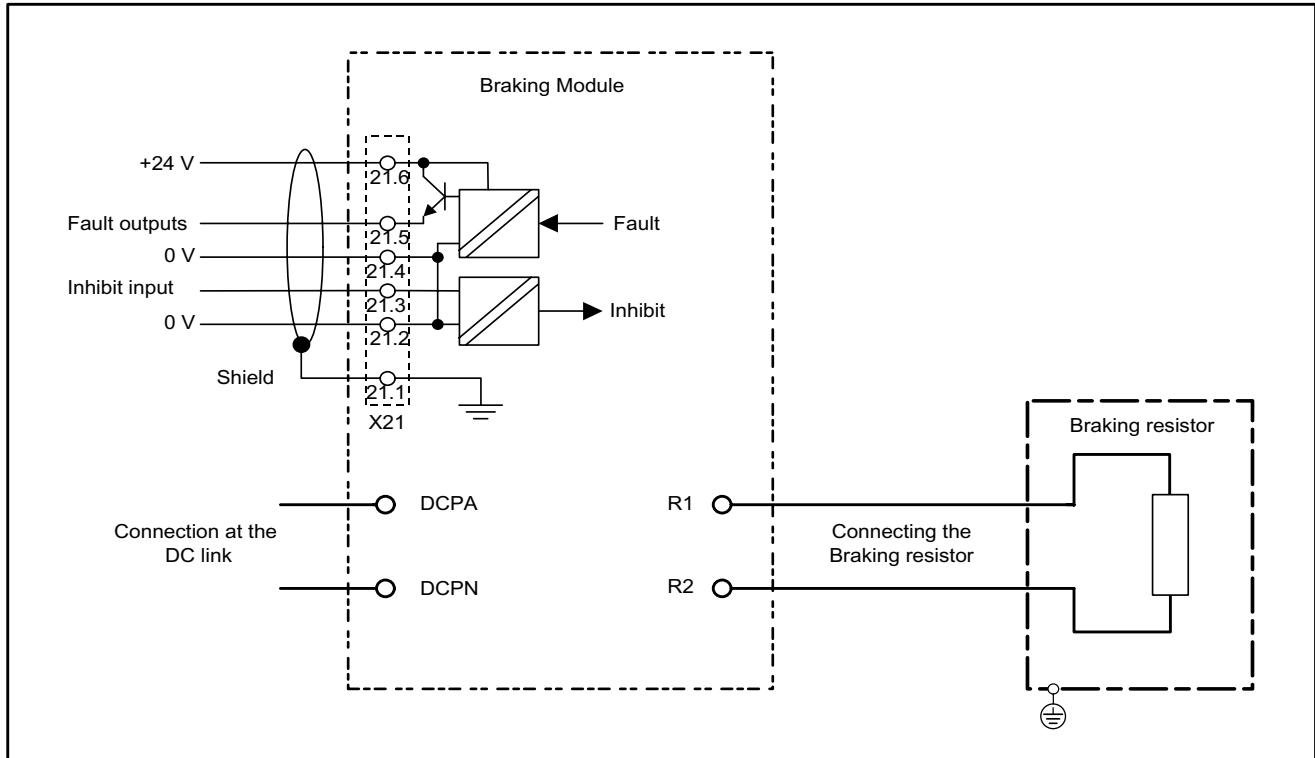

Figure 4-7 Example connection of Braking Module

4.2.1.6 Braking resistor connection X1

Table 4-5 Braking resistor connection

Terminal	Designation
R1	Braking resistor connection R+
R2	Break resistor connection R-
Max. cross-section that can be connected: 50 mm <sup>2</sup>	

### 4.2.1.7 X21 digital inputs/outputs

Table 4-6 Terminal block X21

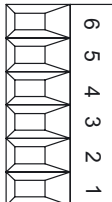
	Terminal	Designation <sup>1)</sup>	Technical specifications
	6	+24 V	Voltage: +18 V to 30 V Typical current consumption (own current consumption): 10 mA at 24 V DC
	5	DO fault output	Voltage: 24 V DC Load current: 0.5 mA to 0.6 mA
	4	0 V	
	3	DI inhibit input	High signal level: +15 V to 30 V Current drain: 2 mA to 15 mA
	2	0 V	Low signal level: -3 V to 5 V
	1	Shield	Shield connection for terminal 2 ... 6
Max. cross-section that can be connected 1.5 mm <sup>2</sup>			

1) DI: Digital input; DO: Digital output

#### Note

Applying a high signal to terminal X21.3 inhibits the Braking Module. On a falling edge, pending error signals are acknowledged.

### 4.2.1.8 S1 threshold value switch

The response threshold at which the Braking Module is activated and the DC link voltage generated during braking are specified in the following table.



#### Warning

The threshold switch must only be used when the Power Module is switched off and the DC link capacitors are discharged.

Table 4-7 Response thresholds of the Braking Modules

Response threshold	Switch position	Comment
774 V	1	774 V is the default factory setting. With supply voltages of between 3-ph. 380 V and 400 V AC, the response threshold can be set to 673 V to reduce the voltage stress on the motor and converter. This does, however, reduce the possible peak power P15 with the square of the voltage $(677/774)^2 = 0.75$ . The possible peak power is, therefore, max. 75 % of P15.
673 V	2	

### 4.2.1.9 Installing a Braking Module in a Power Module, frame size FX

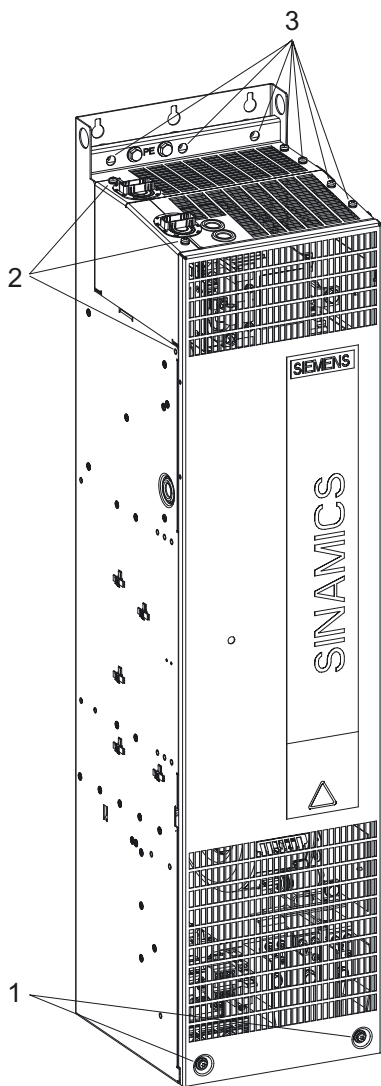

Figure 4-8 Installing a Braking Module in a Power Module, frame size FX – steps 1 - 3



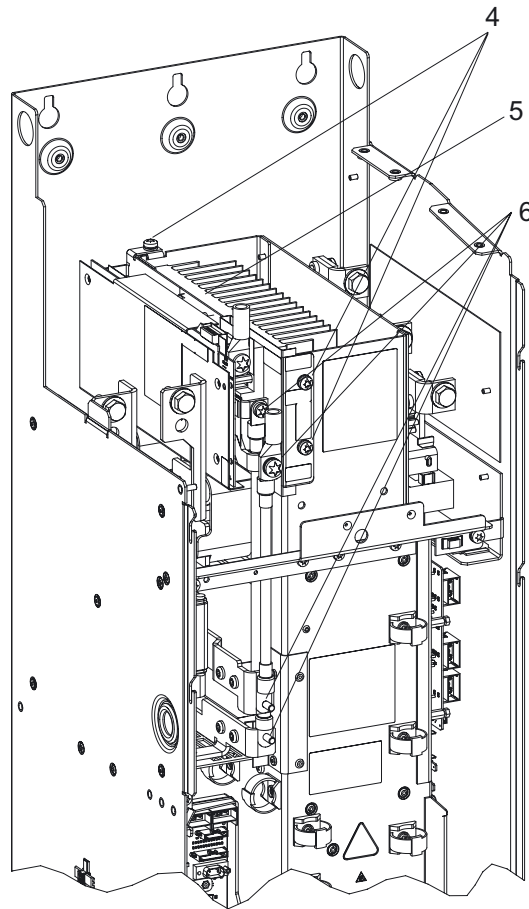

Figure 4-9 Installing a Braking Module in a Power Module, frame size FX – steps 4 - 6

### Installing the Braking Module

The steps for the installation procedure are numbered in accordance with the diagrams in front of them.

1. Unscrew the 2 M6 screws from the front cover and lift off the cover.
2. Unscrew the 2 screws from the upper cover plate.  
Unscrew the 1 M6 nut on the left-hand side.  
Remove the left-hand cover.
3. Unscrew the 4 screws from the upper cover plate.  
Unscrew the 3 screws from the rear cut-out sections.  
Remove the top cover.
4. Unscrew the 3 screws for the blanking plate.  
Remove the plate.
5. Insert the Braking Module where the cover used to be and secure it using the 3 screws (step 4).

6. Secure the connection cable to the DC link with 2 screws (Braking Module connection) and 2 nuts (DC link connection).

Carry out the subsequent steps in reverse order from steps 1 – 3.

An opening above the connections for the braking resistor (R1, R2) is provided in the cover for connecting the cable to the braking resistor.

---

**Note**

You must observe the specified tightening torques.

---

#### 4.2.1.10 Installing a Braking Module in a Power Module, frame size GX

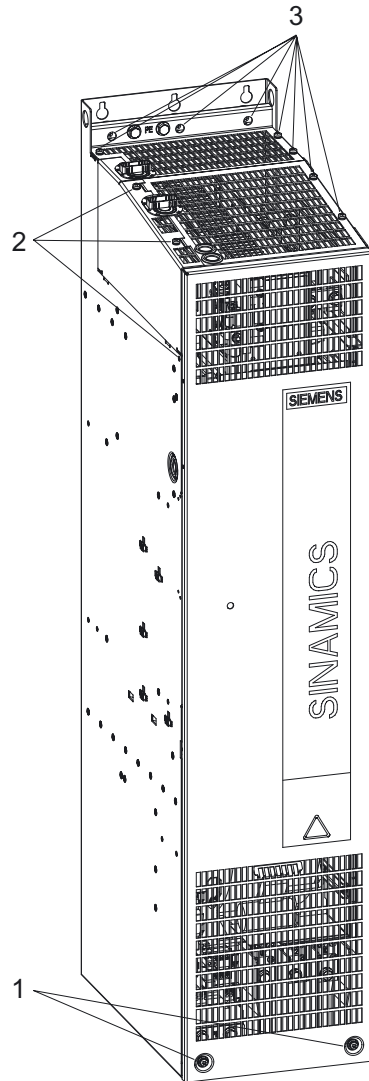

Figure 4-10 Installing a Braking Module in a Power Module, frame size GX – steps 1 - 3

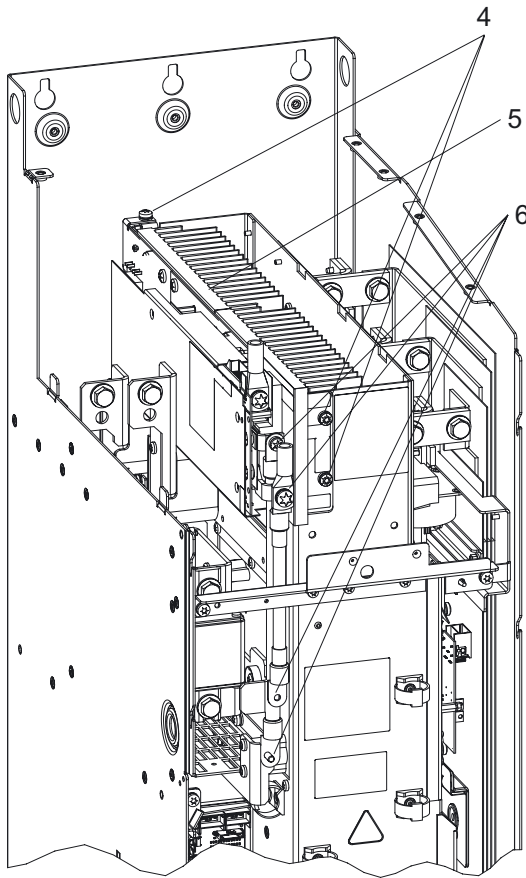

Figure 4-11 Installing a Braking Module in a Power Module, frame size GX – steps 4 - 6

### Installing the Braking Module

The steps for the installation procedure are numbered in accordance with the diagrams in front of them.

1. Unscrew the 2 M6 screws from the front cover and lift off the cover.
2. Unscrew the 2 screws from the upper cover plate.  
Unscrew the 1 M6 nut on the left-hand side.  
Remove the left-hand cover.
3. Unscrew the 4 screws from the upper cover plate.  
Unscrew the 3 screws from the rear cut-out sections.  
Remove the top cover.
4. Unscrew the 3 screws for the blanking plate.  
Remove the plate.
5. Insert the Braking Module where the cover used to be and secure it using the 3 screws (step 4).
6. Secure the connection cable to the DC link with 2 screws (Braking Module connection) and 2 nuts (DC link connection).

Carry out the subsequent steps in reverse order from steps 1 – 3.

An opening above the connections for the braking resistor (R1, R2) is provided in the cover for connecting the cable to the braking resistor.

---

#### Note

You must observe the specified tightening torques.

---

### 4.2.1.11 Technical data

Table 4-8 Technical data, Braking Modules

Order No.	6SL3300-1AE31-3AA0	6SL3300-1AE32-5AA0
Suitable for installation in Power Modules, frame size	FX	GX
P <sub>DB</sub> power (rated power)	25 kW	50 kW
P <sub>15</sub> power (peak power)	125 kW	250 kW
P <sub>20</sub> power	100 kW	200 kW
P <sub>40</sub> power	50 kW	100 kW
Variable response thresholds	774 V (673 V)	774 V (673 V)
<b>Digital input</b>		
Rated voltage	-3 V to 30 V	-3 V to 30 V
Low level (an open digital input is interpreted as "low")	-3 V to 5 V	-3 V to 5 V
High level	15 V to 30 V	15 V to 30 V
Current drain (typical at 24 V DC)	10 mA	10 mA
Max. cross-section that can be connected	1.5 mm <sup>2</sup> (AWG 14)	1.5 mm <sup>2</sup> (AWG 14)
<b>Digital output (continued-short-circuit-proof)</b>		
Rated voltage	24 V DC	24 V DC
Max. load current of the digital output	500 mA	500 mA
Max. cross-section that can be connected	1.5 mm <sup>2</sup> (AWG 14)	1.5 mm <sup>2</sup> (AWG 14)
R1/R2 connection	M8 screw	M8 screw
Max. connection cross-section R1/R2	35 mm <sup>2</sup>	50 mm <sup>2</sup>
Weight	3.6 kg	7.3 kg

## 4.2.2 Braking resistors

### 4.2.2.1 Description

The braking resistor is used to reduce the excess DC link energy in regenerative operation.

The braking resistor is connected to the Braking Module. The braking resistor is mounted outside the cabinet or switchgear room. This means that the resulting heat loss around the Power Module can be dissipated - and cooling costs/equipment reduced.

Resistors with rated powers of 25 kW and 50 kW are available.

Braking resistors can be used on Power Modules with a voltage range. This is the reason that the voltage can be changed by setting the response thresholds at the Braking Module to reduce the voltage stress on the motor and Power Module.

A temperature protection switch monitors the braking resistor for overtemperature and issues a signal on a floating contact if the limit value is exceeded.

### 4.2.2.2 Safety information



---

#### Caution

A cooling clearance of 200 m must be maintained on all sides of the component (with ventilation meshes).

---



---

#### Danger

The braking resistor cables must be laid in such a way that they are short-circuit and ground-fault proof!

---



---

#### Caution

The connecting cables to the Braking Module in the Power Module must be kept as short as possible (max. 50 m).

---



**Danger**

The braking resistors are only suitable for mounting in a vertical position. They are not suitable for mounting on a wall.

Sufficient space must be available for dissipating the energy converted by the braking resistor.

A sufficient distance from flammable objects must be maintained.

The braking resistor must be installed as a free-standing unit.

Objects must not be placed on or anywhere above the braking resistor.

The braking resistor should not be installed underneath fire detection systems, since these could be triggered by the resulting heat.

The surface temperature of the braking resistors may exceed 80 °C.

**4.2.2.3 Dimension drawing**

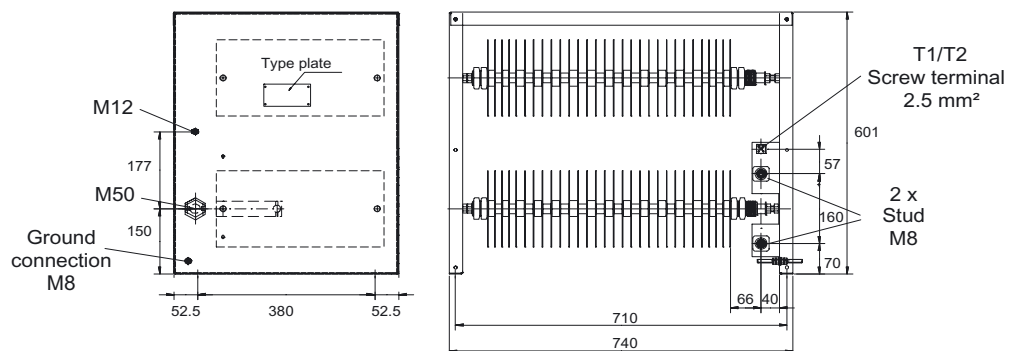

Figure 4-12 Dimension drawing, 25 kW/125 kW resistor

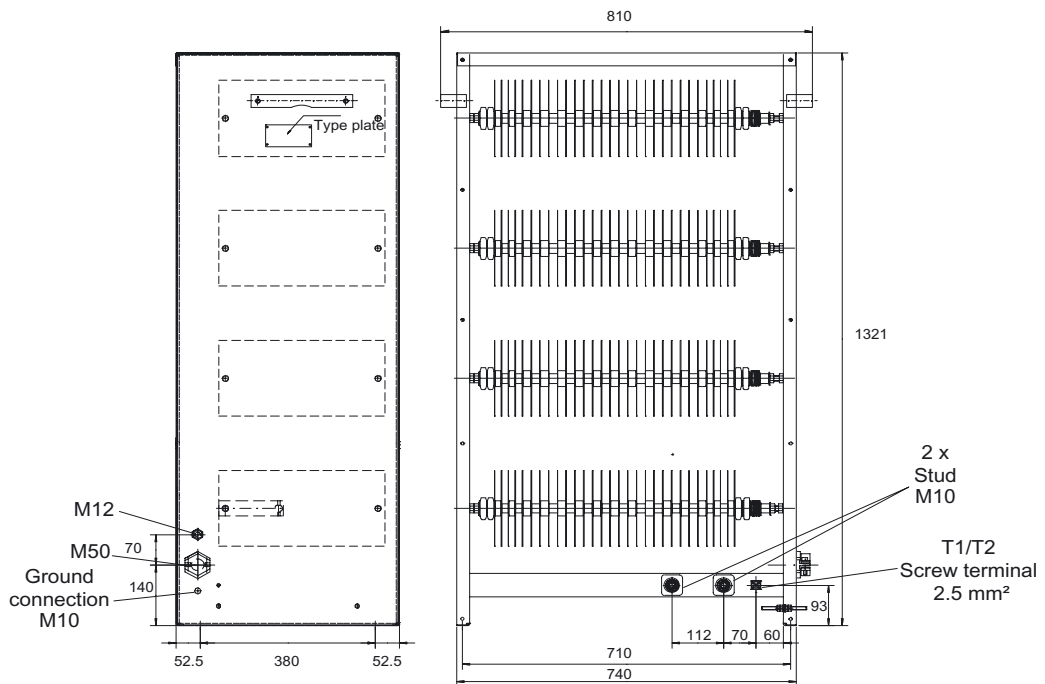

Figure 4-13 Dimension drawing, 50 kW/250 kW resistor

#### 4.2.2.4 Technical data

Table 4-9 What are the technical data of the braking resistors

Order No.	Units	6SL3000-1BE31-3AA0	6SL3000-1BE32-5AA0
P <sub>DB</sub> power (rated power)	kW	25	50
P <sub>15</sub> power (peak power)	kW	125	250
Max. current	A	189	378
Cable entry		Via cable gland M50	Via cable gland M50
Line connection		Via stud M10	Via stud M10
Max. cable cross-section that can be connected	mm <sup>2</sup>	50	70
Degree of protection		IP 20	IP 20
Width x height x depth	mm	740 x 605 x 485	740 x 1325 x 485
Weight	kg	50	120



## Duty cycle

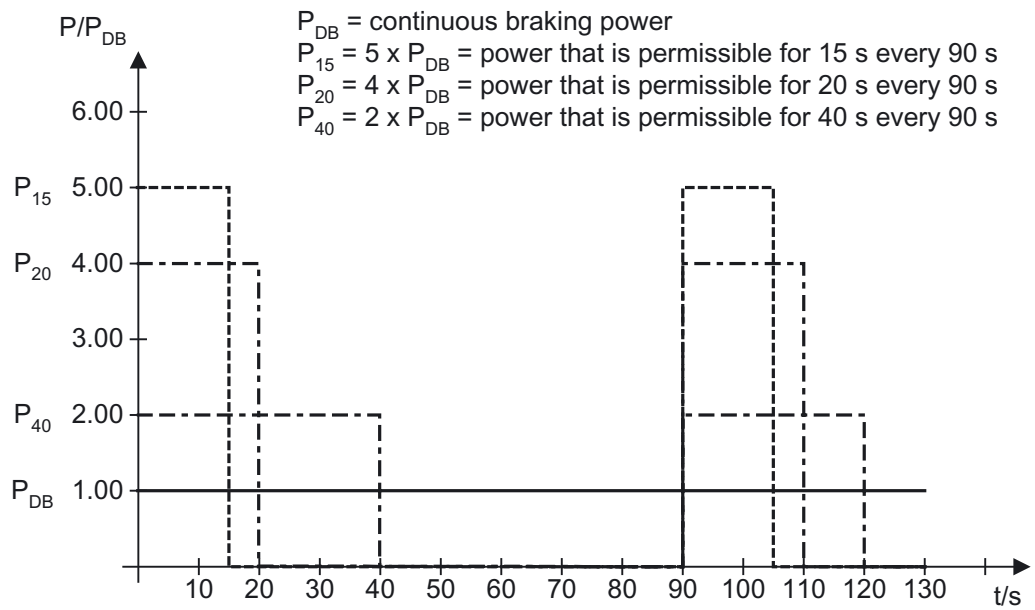

Figure 4-14 Duty cycle for braking resistors



## Motor-side power components

### 5.1 Motor reactors

#### 5.1.1 Blocksize

##### 5.1.1.1 Description

Motor reactors reduce the voltage stress on the motor windings by reducing the voltage gradients at the motor terminals that occur when motors are fed from drive converters. At the same time, the capacitive re-charging currents that additionally load the output of the Power Module when longer motor cables are used are simultaneously reduced.

The motor reactors for Power Modules 3-ph. 380 V to 480 V AC are suitable for a pulse frequency of 4 kHz. Higher pulse frequencies are not permissible.

##### 5.1.1.2 Safety information



---

###### Caution

The cooling clearances of 100 mm above and below the components must be observed.

---

###### Note

The connecting cables to the Power Module must be kept as short as possible (max. 5 m).

---

###### Caution

When using motor reactors that SIEMENS has not approved for SINAMICS, then these can thermally damage the reactor.

---



---

###### Caution

The surface temperature of the motor reactors can exceed 80 °C.

---

###### Caution

The maximum permissible output frequency when motor reactors are used is 150 Hz.

---

5.1.1.3 Dimension drawings

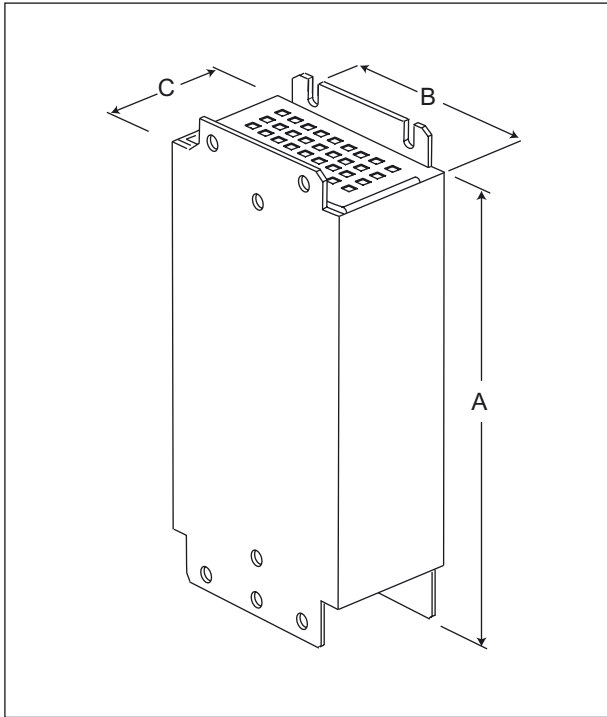

Figure 5-1 Dimension drawing: Motor reactor, frame size A

Table 5-1 Total dimensions: Motor reactor, frame size A, all data in mm and (inches)

Motor reactor 6SE6400-	3TC00-4AD3	3TC00-4AD2
Frame size	A	A
Dimension A in mm and (inches)	200 (7.87)	200 (7.87)
Dimension B in mm and (inches)	75.5 (2.97)	75 (2.95)
Dimension C in mm and (inches)	50 (1.96)	110 (4.33)

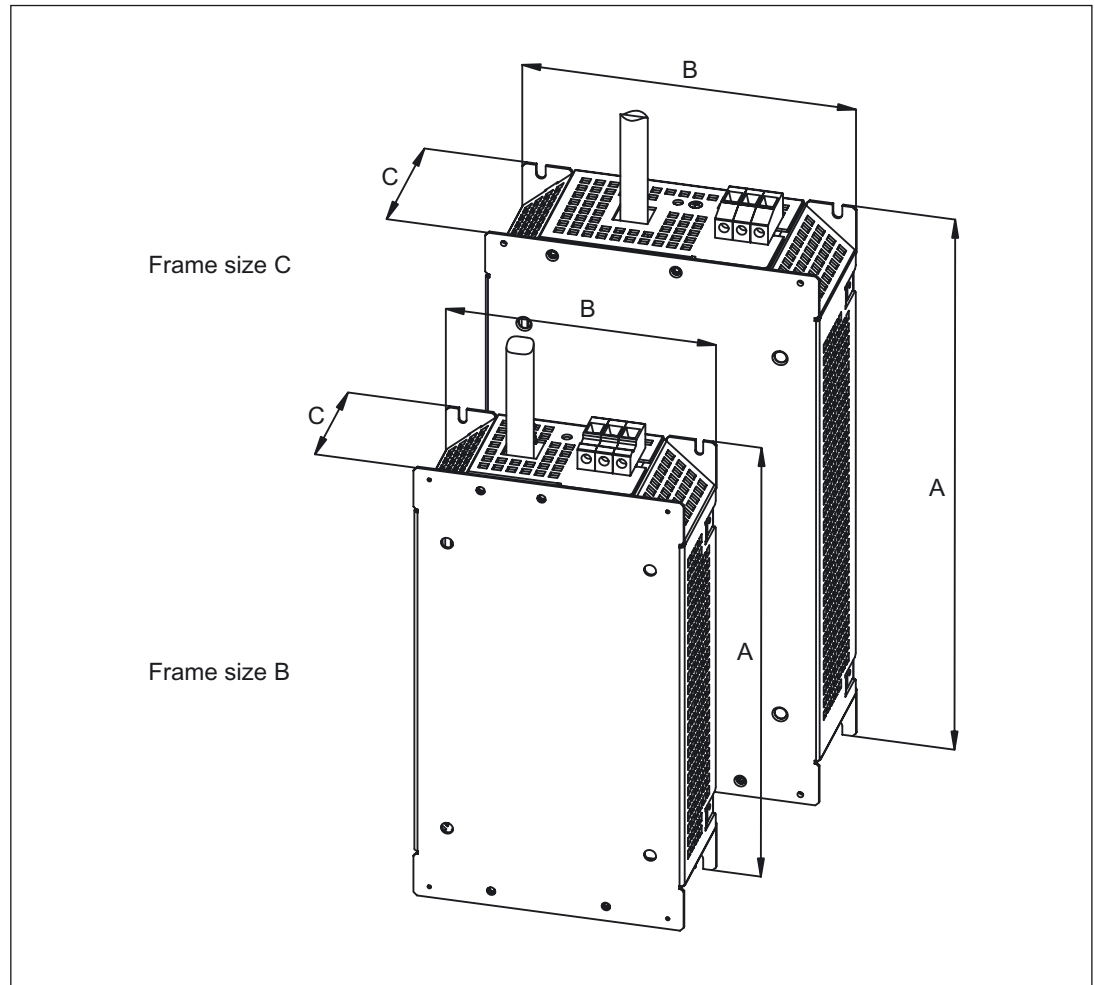

Figure 5-2 Dimension drawing: Motor reactor, frame sizes B and C

Table 5-2 Total dimensions: Motor reactor, frame sizes B and C

Motor reactor 6SL3202-	0AE21-0CA0	0AJ23-2CA0
Frame size	B	C
Dimension A in mm and (inches)	270 (10.62)	334 (13.14)
Dimension B in mm and (inches)	153 (6.02)	189 (7.44)
Dimension C in mm and (inches)	70 (2.75)	50 (1.96)

5.1 Motor reactors

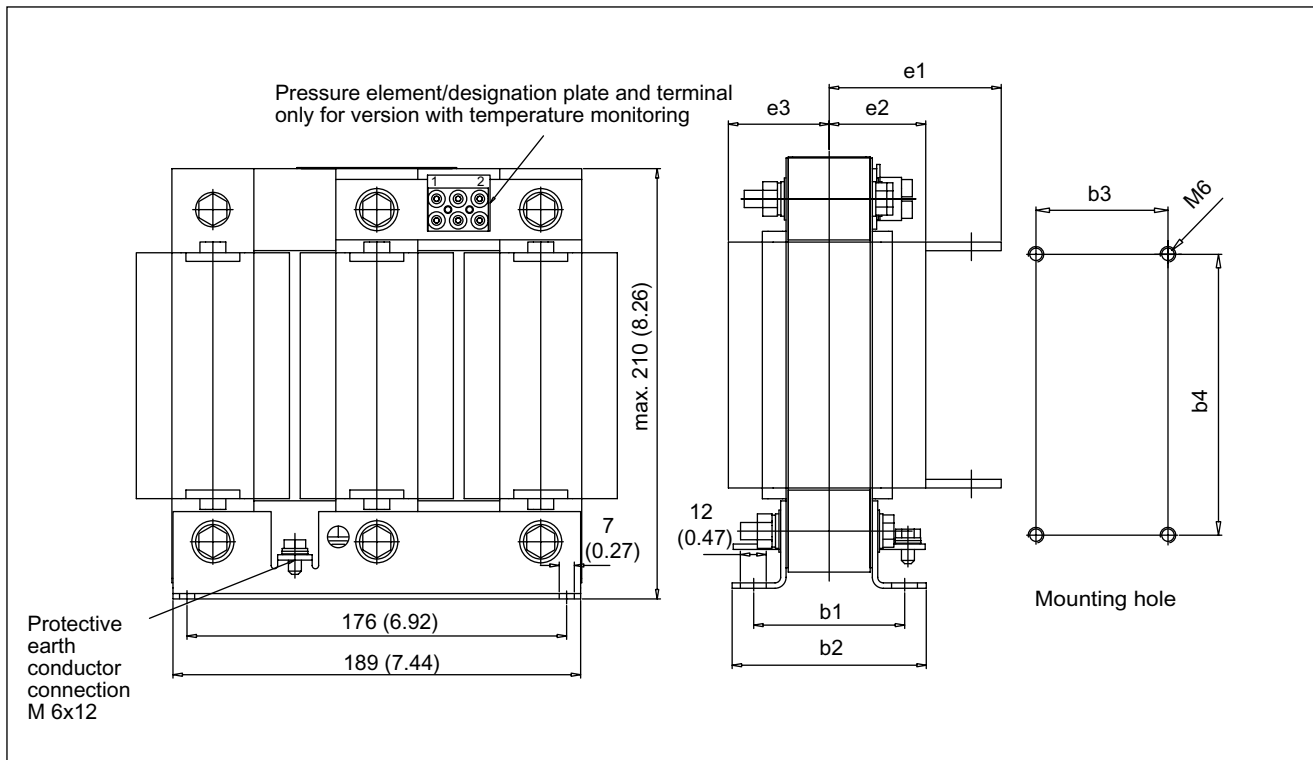

Figure 5-3 Dimension drawing: Motor reactor, frame size D

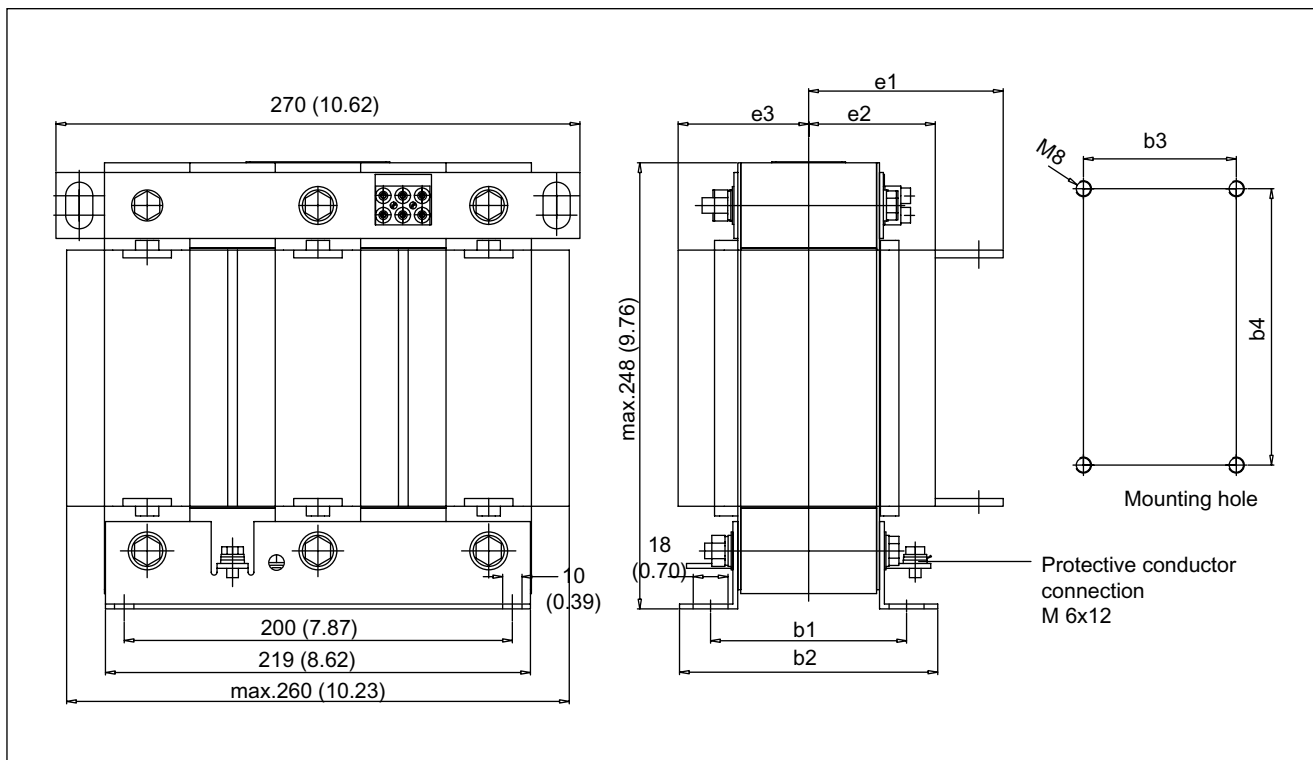

Figure 5-4 Dimension drawing: Motor reactor, frame size E

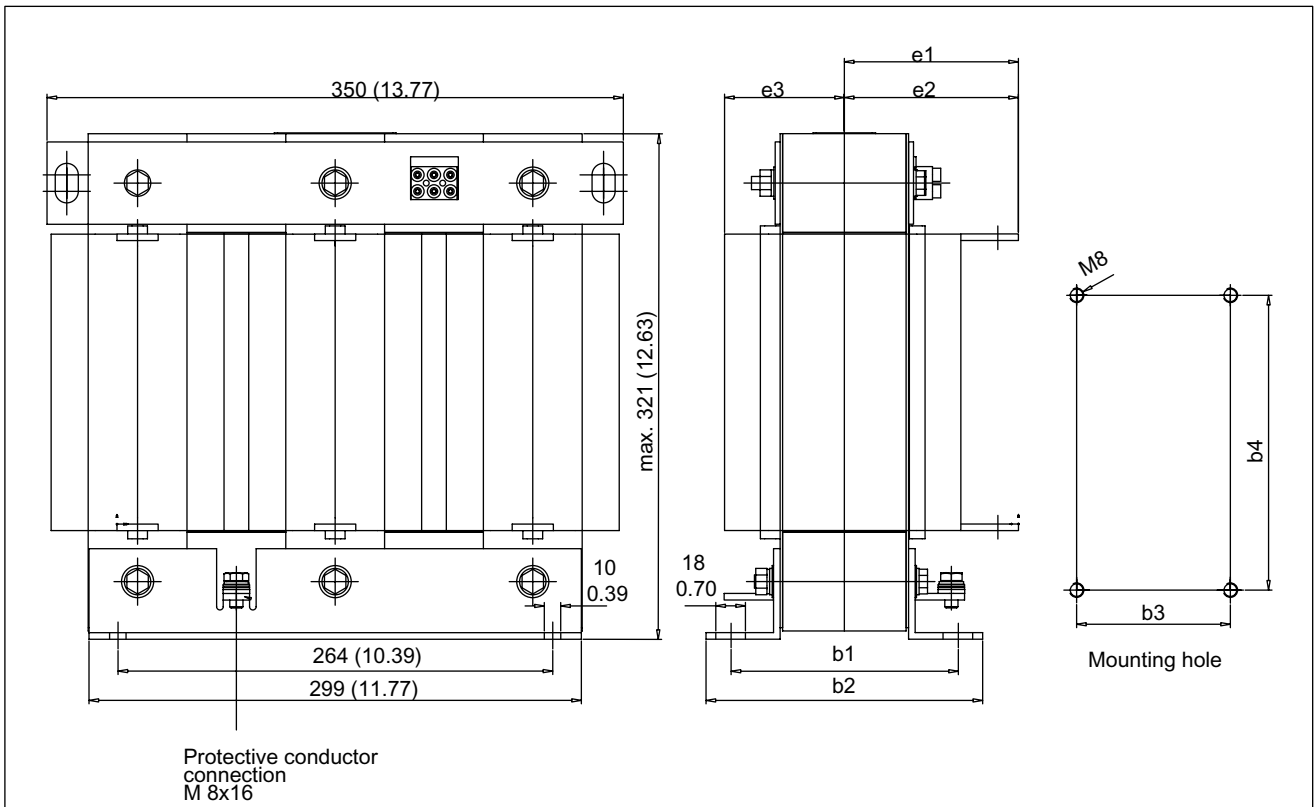

Figure 5-5 Dimension drawing: Motor reactor, frame size F

Table 5-3 Total dimensions: Motor reactor, frame size D, E, all data in mm and (inches)

Motor reactor 6SE6400-	3TC05-4DD0	3TC03-8DD0	3TC07-5ED0	3TC08-0ED0
Frame size	D	D	E	E
b1	70 (2.75)	94 (3.70)	101 (3.97)	70 (2.75)
b2	91 (3.58)	115 (4.52)	133 (5.23)	90 (3.54)
b3	70 (2.75)	94 (3.70)	101 (3.97)	70 (2.75)
b4	176 (6.92)	176 (6.92)	200 (7.87)	176 (6.92)
e1	91 (3.58)	103 (4.05)	110 (4.33)	89 ± 2 (3.50 ± 0.07)
e2	57 (2.24)	69 (2.71)	76 (2.99)	79 ± 2 (3.50 ± 0.07)
e3	49 (1.92)	61 (2.40)	68 (2.67)	-

5.1 Motor reactors

Table 5-4 Total dimensions: Motor reactor, frame size F, all data in mm and (inches)

Motor reactor 6SE6400-	3TC06-2FE0	3TC08-8FE0	3TC14-5FD0	3TC15-4FD0
Frame size	F	F	F	F
b1	118 (4.64)	138 (5.43)	138 (5.43)	101 (3.97)
b2	138 (5.43)	158 (6.22)	169 (6.65)	121 (4.76)
b3	118 (4.64)	138 (5.43)	138 (5.43)	101 (3.97)
b4	224 (8.81)	264 (10.39)	264 (10.39)	200 (7.87)
e1	124 ± 2 (4.88 ± 0.07)	134 ± 2 (5.27 ± 0.07)	131 (5.15)	119 ± 2 (4.68 ± 0.07)
e2	114 ± 2 (4.48 ± 0.07)	124 ± 2 (4.88 ± 0.07)	90 (3.54)	109 ± 2 (4.29 ± 0.07)
e3	-	-	78 (3.07)	-



### 5.1.1.4 Mounting

The motor reactor must be installed as close as possible to the Power Module.

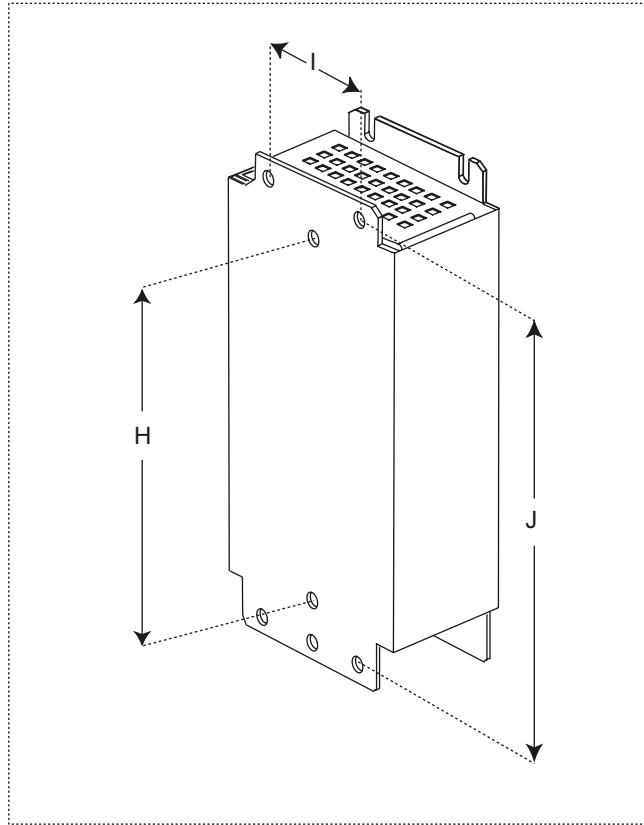

Figure 5-6 Mounting: Motor reactor, frame size A

Table 5-5 Mounting: Motor reactor, frame size A, all data in mm and (inches)

Motor reactor 6SE6400-	3TC00-4AD3	3TC00-4AD2
Suitable for Power Modules 6SL3210-	1SB11-0UA0	1SE11-3UA0 1SE11-7UA0 1SE12-2UA0 1SE13-1UA0 1SE14-1UA0
<b>Frame size</b>	<b>A</b>	<b>A</b>
H	160 (6.29)	160 (6.29)
I	56 (2.20)	56 (2.20)
J	187 (7.36)	187 (7.36)

5.1 Motor reactors

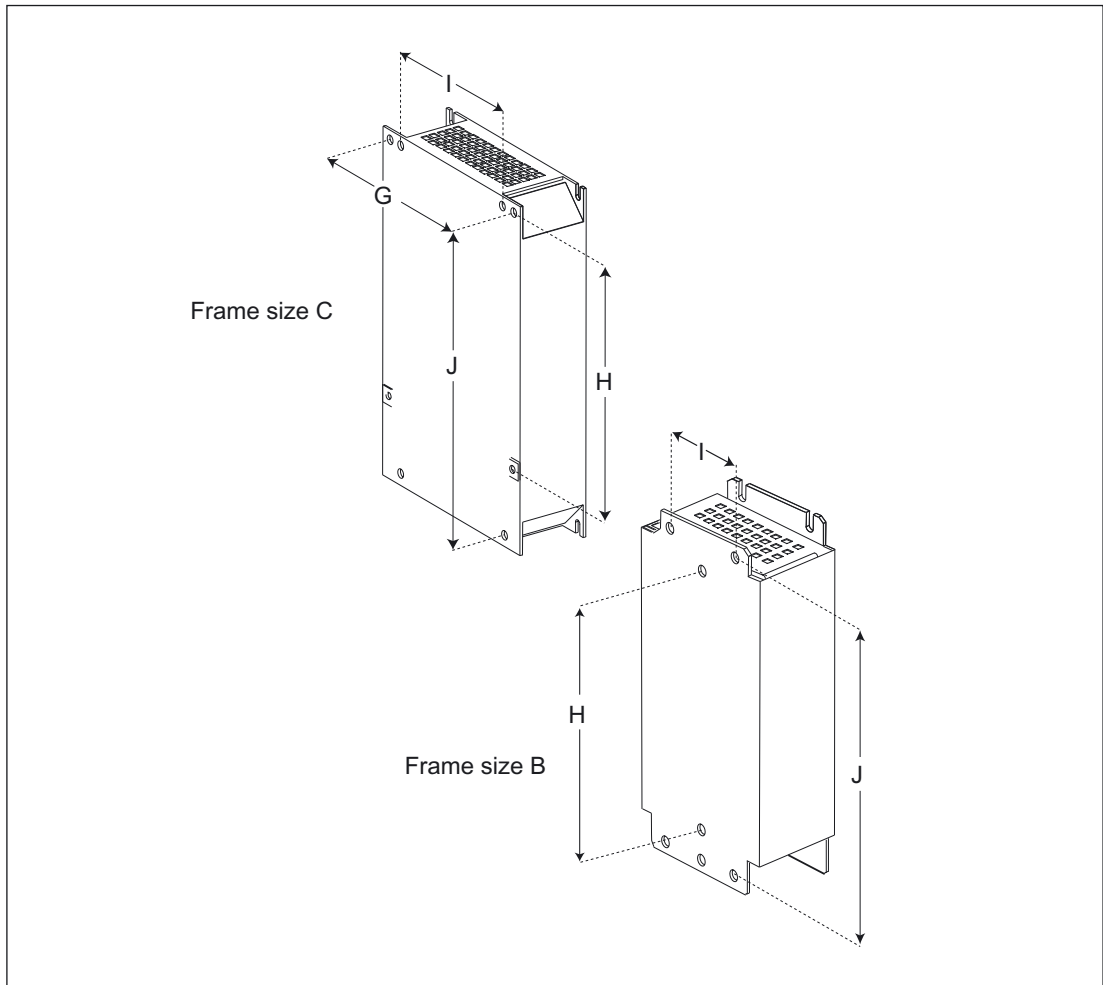

Figure 5-7 Mounting: Motor reactor, frame sizes B and C

Table 5-6 Mounting: Motor reactor, frame size B and C, all data in mm and (inches)

Motor reactor	6SL3202-	0AE21-0CA0	0AJ23-2CA0
Suitable for Power Module	6SL3210-	1SE16-0UA0 1SE17-7UA0 1SE21-0UA0	1SE21-8UA0 1SE22-5UA0 1SE23-2UA0
Frame size		B	C
Power Module	G	138 (5.43)	174 (6.85)
	H	174 (6.85)	204 (8.03)
Mounting surface	I	120 (4.72)	156 (6.14)
	J	200 (7.87)	232 (9.13)
Mounting screw		M4	M5

**Cable cross-section and terminal tightening torques**  
**Terminals for wiring on site**

<b>Frame size</b>	<b>A</b>	<b>B</b>	<b>C</b>
Tightening torque [Nm]	1.1	1.5	2.25
Recommended minimum conductor cross-section [mm <sup>2</sup> ]	1	1.5	2.5
Highest conductor cross-section [mm <sup>2</sup> ]	2.5	6	10

5.1 Motor reactors

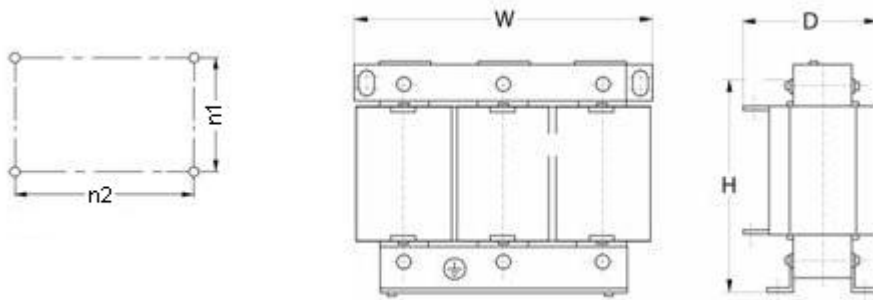

Figure 5-8 Mounting: Motor reactor, frame sizes D, E, F

Table 5-7 Mounting: Motor reactor, frame sizes D, E, all data in mm and (inches)

Motor reactor	6SE6400-	3TC05-4DD0	3TC03-8DD0	3TC05-4DD0	3TC07-5ED0	3TC08-0ED0
Suitable for Power Module	6SL3210-	1SE23-8UA0	1SE24-5UA0	1SE26-0UA0	1SE27-5UA0	1SE31-0UA0
Frame size		D	D	D	E	E
Motor reactor	H	210 (8.26)	210 (8.26)	210 (8.26)	210 (8.26)	248 (9.76)
	W	225 (8.85)	225 (8.85)	225 (8.85)	225 (8.85)	270 (10.62)
	D	150 (5.90)	179 (7.04)	179 (7.04)	150 (5.90)	209 (8.22)
Mounting dimensions	n1	70 (2.75)	94 (3.70)	94 (3.70)	70 (2.75)	101 (3.97)
	n2	176 (6.29)	176 (6.92)	176 (6.92)	176 (6.92)	200 (7.87)
Mounting screw	H	M6	M6	M6	M6	M8
Tightening torque [Nm]		3.5-4.0	3.5-4.0	3.5-4.0	4.8-5.0	4.8-5.0

Table 5-8 Mounting: Motor reactor, frame size F, all data in mm and (inches)

Motor reactor	6SE6400-	3TC06-2FE0	3TC08-8FE0	3TC14-5FD0	3TC15-4FD0
Suitable for Power Module	6SL3210-	?	?	1SE31-1UA0	1SE31-5UA0
Frame size		F	F	F	F
Motor reactor	H	248 (9.76)	321 (12.63)	269 (10.59)	321 (12.63)
	W	270 (10.62)	350 (13.77)	300 (11.81)	350 (13.77)
	D	209 (8.22)	288 (11.33)	220 (8.66)	288 (11.33)
Mounting dimensions	n1	101 (3.97)	138 (5.43)	118 (4.64)	138 (5.43)
	n2	200 (7.87)	264 (10.39)	224 (8.81)	264 (10.39)
Mounting screw	H	M8	M8	M8	M8
Tightening torque [Nm]		9.5-10.0	9.5-10.0	4.8-5.0	9.5-10.0

Mounting Power Modules and motor reactors

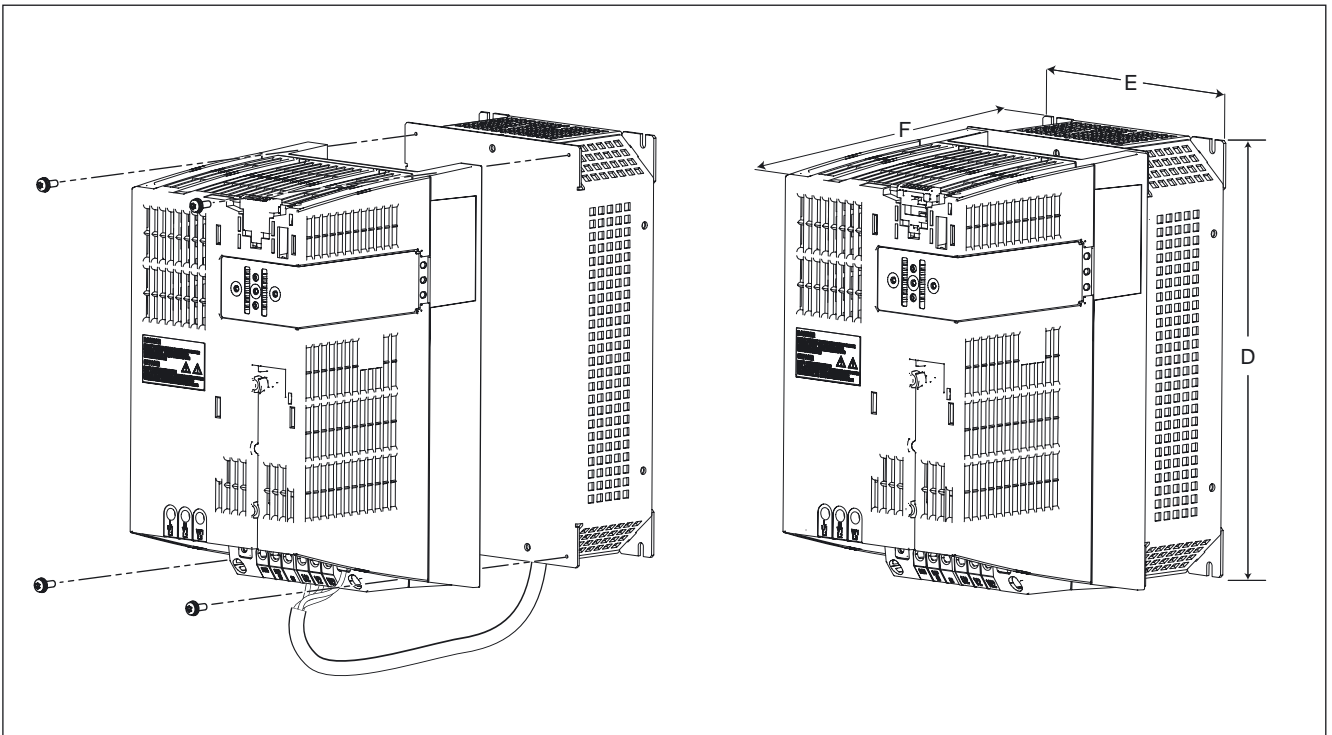

Figure 5-9 Mounting Power Modules and motor reactors, frame sizes B and C

Table 5-9 Total dimensions, Power Module 340 and motor reactor, frame sizes A, B and C, all data in mm and (inches)

Motor reactor		6SE6400-3TC00-4AD3	6SE6400-3TC00-4AD2	6SL3202-0AE21-0CA0	6SL3202-0AJ23-2CA0
Suitable for Power Module	6SL3210-	1SB11-0UA0	1SE11-3UA0 1SE11-7UA0 1SE12-2UA0 1SE13-1UA0 1SE14-1UA0	1SE16-0UA0 1SE17-7UA0 1SE21-0UA0	1SE21-8UA0 1SE22-5UA0 1SE23-2UA0
Frame size		A	A	B	C
Total dimension of the Power Module and motor reactor	D	200 (7.87)	200 (7.87)	270 (10.62)	334 (13.14)
	E	75.5 (2.97)	75.5 (2.97)	153 (6.02)	189 (7.44)
	F	259 (10.19)	259 (10.19)	235 (9.25)	245 (9.64)

5.1.1.5 Electrical connection

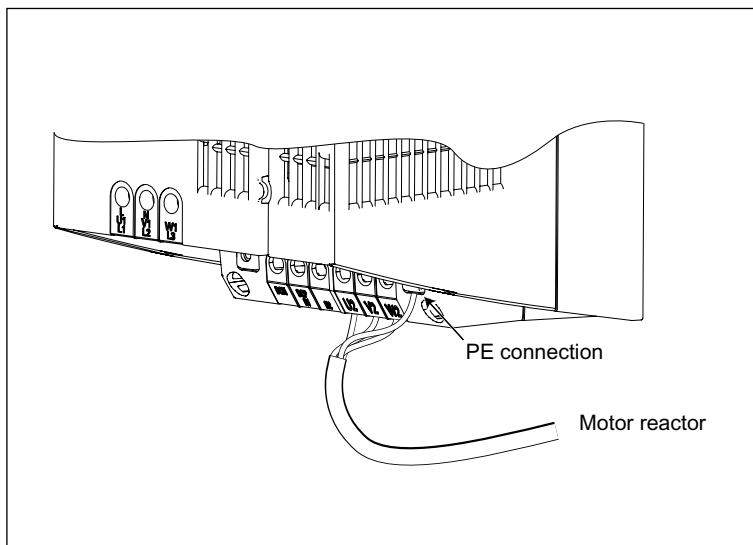

Figure 5-10 Electrical connection

5.1.1.6 Technical data

Table 5-10 Motor reactors for Power Modules 3-ph. 380 V to 480 V AC, Part 1

		Motor reactor (for a 4 kHz pulse frequency)						
		6SE6400-3TC00-4AD2					6SL3202-0AE21-0CA0	
Rated current	A	4.5					10	
Power loss	kW	0.005					0.02	
Connection to the Power Module		Cable 4 x 1.5 mm <sup>2</sup> Length approx. 0.3 m					Cable 4 x AWG14 (1.5 mm <sup>2</sup> ) Length approx. 0.4 m	
Motor connection		Screw terminals for cable cross-section 6 mm <sup>2</sup>					Screw terminals for cable cross- section 6 mm <sup>2</sup>	
PE connection		M5 stud					M5 stud	
Max. permissible cable length between motor reactor and motor	m	100 (shielded) 150 (non-shielded)	100 (shielded) 150 (non-shielded)	100 (shielded) 150 (non-shielded)	100 (shielded) 225 (non-shielded)	100 (shielded) 225 (non-shielded)	100 (shielded) 150 (non-shielded)	
Degree of protection		IP20 or IPXXB	IP20 or IPXXB	IP20 or IPXXB	IP20 or IPXXB	IP20 or IPXXB	IP20 or IPXXB	
Weight, approx.	kg	2					4.5	
Suitable for Power Module, Blocks size format	Type	6SL3210-1SE11-3UA0	6SL3210-1SE11-7UA0	6SL3210-1SE12-2UA0	6SL3210-1SE13-1UA0	6SL3210-1SE14-1UA0	6SL3210-1SE16-0UA0 6SL3210-1SE16-0AA0	
Rated current I <sub>n</sub> (power) of the Power Module	A	1.3	1.7	2.2	3.1	4.1	5.9	
Frame size		A	A	A	A	A	B	

Motor-side power components

5.1 Motor reactors

Table 5-11 Motor reactors for Power Modules 3-ph. 380 V to 480 V AC, Part 2

		Motor reactor (for a 4 kHz pulse frequency)					
		6SL3202-0AE21-0CA0		6SL3202-0AJ23-2CA0			6SE6400-3TC05-4DD0
Rated current	A	10		25			68
Power loss	kW	0.02		0.06			0.2
Connection to the Power Module		Cable 4 x AWG14 (1.5 mm <sup>2</sup> ) Length approx. 0.4 m		Cable 4 x AWG14 (1.5 mm <sup>2</sup> ) Length approx. 0.35 m			Flat terminator for M6 cable lug
Motor connection		Screw terminals for cable cross-section 6 mm <sup>2</sup>		Screw terminals for cable cross-sections 2.5 to 10 mm <sup>2</sup>			Flat terminator for M6 cable lug
PE connection		M5 stud		M5 stud			M6 screw
Max. permissible cable length between motor reactor and motor	m	100 (shielded) 150 (non-shielded)	100 (shielded) 150 (non-shielded)	100 (shielded) 150 (non-shielded)	100 (shielded) 150 (non-shielded)	100 (shielded) 150 (non-shielded)	200 (shielded) 300 (non-shielded)
Degree of protection		IP20 or IPXXB		IP20 or IPXXB			IP00
Weight, approx.	kg	4.5		9			11.5
Suitable for Power Module, Blocksize format	Type	6SL3210-1SE17-7UA0 6SL3210-1SE17-7AA0	6SL3210-1SE21-0UA0 6SL3210-1SE21-0AA0	6SL3210-1SE21-8UA0 6SL3210-1SE21-8AA0	6SL3210-1SE22-5UA0 6SL3210-1SE22-5AA0	6SL3210-1SE23-2UA0 6SL3210-1SE23-2AA0	6SL3210-1SE23-8UA0 6SL3210-1SE23-8AA0
Rated current I <sub>n</sub> (power) of the Power Module	A	7.7	10	18	25	32	38
Frame size		B	B	C	C	C	D



Table 5-12 Motor reactors for Power Modules 3-ph. 380 V to 480 V AC, Part 3

		Motor reactor (for a 4 kHz pulse frequency)					
		6SE6400-3TC03-8DD0	6SE6400-3TC05-4DD0	6SE6400-3TC08-0ED0	6SE6400-3TC07-5ED0	6SE6400-3TC14-5FD0	6SE6400-3TC15-4FD0
Rated current	A	45	68	104	90	178	178
Power loss	kW	0.2	0.2	0.17	0.28	0.47	0.25
Connection to the Power Module		Flat terminator for M6 cable lug	Flat terminator for M6 cable lug	Flat terminator for M6 cable lug	Flat terminator for M6 cable lug	Flat terminator for M8 cable lug	Flat terminator for M8 cable lug
Motor connection		Flat terminator for M6 cable lug	Flat terminator for M6 cable lug	Flat terminator for M6 cable lug	Flat terminator for M6 cable lug	Flat terminator for M8 cable lug	Flat terminator for M8 cable lug
PE connection		M6 screw	M6 screw	M6 screw	M6 screw	M8 screw	M6 screw
Max. permissible cable length between the motor reactor and motor for line supply voltages 380 V to 400 V for line supply voltages 401 V to 480 V	m	200 (shielded) 300 (non-shielded)	200 (shielded) 300 (non-shielded)	200 (shielded) 300 (non-shielded)	200 (shielded) 300 (non-shielded)	200 (shielded) 300 (non-shielded)	200 (shielded) 300 (non-shielded)
Degree of protection		IP00	IP00	IP00	IP00	IP00	IP00
Weight, approx.	kg	19	11.5	12	27	57	24
Suitable for Power Module, Blocksize format	Type	6SL3210-1SE24-5UA0 6SL3210-1SE24-5AA0	6SL3210-1SE26-0UA0 6SL3210-1SE26-0AA0	6SL3210-1SE27-5UA0 6SL3210-1SE27-5AA0	6SL3210-1SE31-0UA0 6SL3210-1SE31-0AA0	6SL3210-1SE31-1UA0 6SL3210-1SE31-1AA0	6SL3210-1SE31-5UA0 6SL3210-1SE31-5AA0
Rated current In (power) of the Power Module	A	45	60	75	90	110	145
Frame size		D	D	E	E	F	F

5.1 Motor reactors

Table 5-13 Motor reactors for Power Modules 3-ph. 380 V to 480 V AC, Part 4

		Motor reactor (for a 4 kHz pulse frequency)
		<b>6SE6400-3TC14-5FD0</b>
Rated current	A	178
Power loss	kW	0.47
Connection to the Power Module		Flat terminator for M8 cable lug
Motor connection		Flat terminator for M8 cable lug
PE connection		M8 screw
Max. permissible cable length between the motor reactor and motor for line supply voltages 380 V to 400 V for line supply voltages 401 V to 480 V	m	200 (shielded) 300 (non-shielded)
Degree of protection		IP00
Weight, approx.	kg	57
Suitable for Power Module, Blocksize format	Type	6SL3210-1SE31-8UA0 6SL3210-1SE31-8AA0
Rated current I <sub>n</sub> (power) of the Power Module	A	178
Frame size		F

5.1.2 Chassis

5.1.2.1 Description

Motor reactors reduce the voltage stress on the motor windings by reducing the voltage gradients at the motor terminals that occur when motors are fed from drive converters. At the same time, the capacitive re-charging currents that additionally load the output of the Power Module when longer motor cables are used are simultaneously reduced.

5.1.2.2 Safety information



**Caution**

The cooling clearances of 100 mm above and below the components must be observed.

**Note**

The connecting cables to the Power Module must be kept as short as possible (max. 5 m).

**Caution**

When using motor reactors that SIEMENS has not approved for SINAMICS, then these can thermally damage the reactor.



**Caution**

The surface temperature of the motor reactors can exceed 80 °C.

**Caution**

The maximum permissible output frequency when motor reactors are used is 150 Hz.

5.1.2.3 Dimension drawing

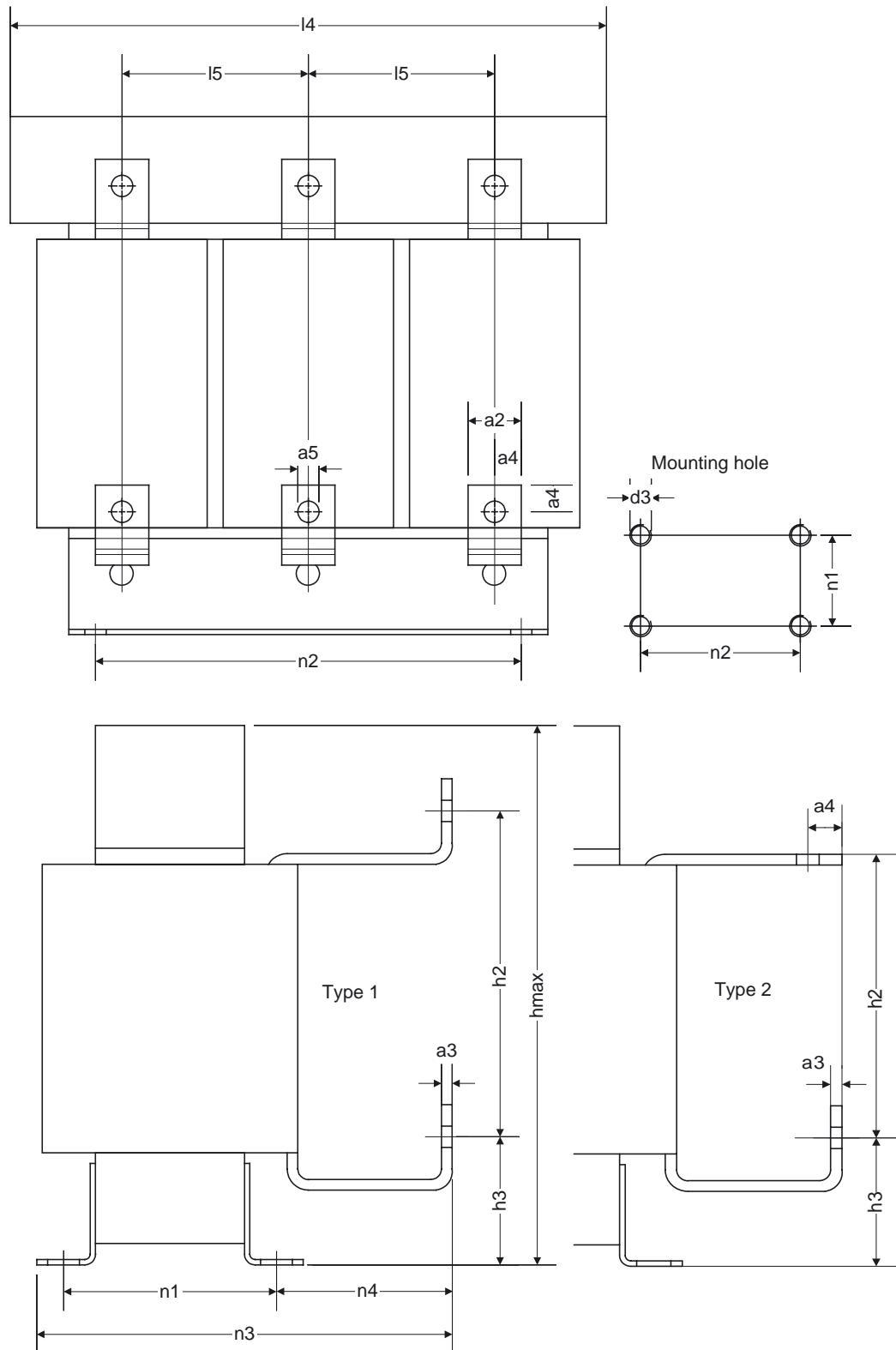

Figure 5-11 Dimension drawing, motor reactor

5.1 Motor reactors

Table 5-14 Dimensions of motor reactors, all data in mm and (inches)

6SL3000-	2BE32-1AA0	2BE32-6AA0	2BE33-2AA0	2BE33-8AA0	2BE35-0AA0
Connection type	1	1	1	1	2
a2	25 (0.98)	25 (0.98)	25 (0.98)	25 (0.98)	30 (1.18)
a3	5 (0.19)	5 (0.19)	5 (0.19)	5 (0.19)	6 (0.23)
a4	12.5 (0.49)	12.5 (0.49)	12.5 (0.49)	12.5 (0.49)	15 (0.59)
a5	11 (0.43)	11 (0.43)	11 (0.43)	11 (0.43)	14 (0.55)
l4	300 (11.81)	300 (11.81)	300 (11.81)	300 (11.81)	300 (11.81)
l5	100 (3.93)	100 (3.93)	100 (3.93)	100 (3.93)	100 (3.93)
hmax	285 (11.22)	315 (12.40)	285 (11.22)	285 (11.22)	365 (14.37)
h2	194 (7.63)	227 (8.93)	194 (7.63)	194 (7.63)	245 (9.64)
h3	60 (2.36)	60 (2.36)	60 (2.36)	60 (2.36)	60 (2.36)
n1 <sup>1)</sup>	163 (6.41)	183 (7.20)	163 (6.41)	183 (7.20)	183 (7.20)
n2 <sup>1)</sup>	224 (8.81)	224 (8.81)	224 (8.81)	224 (8.81)	224 (8.81)
n3	257 (10.11)	277 (10.90)	257 (10.11)	277 (10.90)	277 (10.90)
n4	79 (3.11)	79 (3.11)	79 (3.11)	79 (3.11)	79 (3.11)
d3	M8	M8	M8	M8	M8

1) Lengths n1 and n2 correspond to the distance between holes

5.1.2.4 Technical data

Table 5-15 Technical data, motor reactors

Order No.	6SL3000-	2BE32-1AA0	2BE32-6AA0	2BE33-2AA0	2BE33-8AA0	2BE35-0AA0
Suitable for Power Module	6SL3310-	1TE32-1AA0	1TE32-6AA0	1TE33-1AA0	1TE33-8AA0	1TE35-0AA0
Rated power of the Power Module	kW	110	132	160	200	250
Rated current	A	210	260	310	380	490
Power loss	kW	0.486	0.5	0.47	0.5	0.5
Connections - to the Power Module - to the load - PE		M10 M10 M8	M10 M10 M8	M10 M10 M8	M10 M10 M8	M12 M12 M8
Degree of protection		IP 00	IP 00	IP 00	IP 00	IP 00
Dimensions						
Width	mm	300	300	300	300	300
Height	mm	285	315	285	285	365
Depth	mm	257	277	257	277	277
Weight	kg	66	66	66	73	100

## 5.2 Sinusoidal filter

### 5.2.1 Chassis

#### 5.2.1.1 Description

The sinusoidal filter at the output of the Power Module supplies voltages that are virtually sinusoidal at the motor, thereby enabling standard motors to be used without shielded cables and without the need to reduce the power. Non-shielded cables can be used and, if long motor supply cables are used, no additional motor reactors are required.

Sinusoidal filters with a power rating of up to 200 kW are available

The pulse frequency of the Motor Modules must be set to 4 kHz for the sinusoidal filters. This reduces the output current of the Power Module, refer to Chapter Technical data.

When a sinusoidal filter is used, the available output voltage decreases by 15 %.

#### 5.2.1.2 Safety information



---

##### Caution

The cooling clearances of 100 mm above and below the components must be observed.

---

##### Note

The connecting cables to the Power Module must be kept as short as possible (max. 5 m).

---

##### Caution

Using sinusoidal filters that have not been approved by SIEMENS for SINAMICS can:

- damage/destroy the Power Modules
  - cause line harmonics that may interfere with or damage other loads connected to the same line supply.
- 



---

##### Caution

The sinusoidal filters can have surface temperatures of over 80 °C.

---

5.2.1.3 Dimension drawing

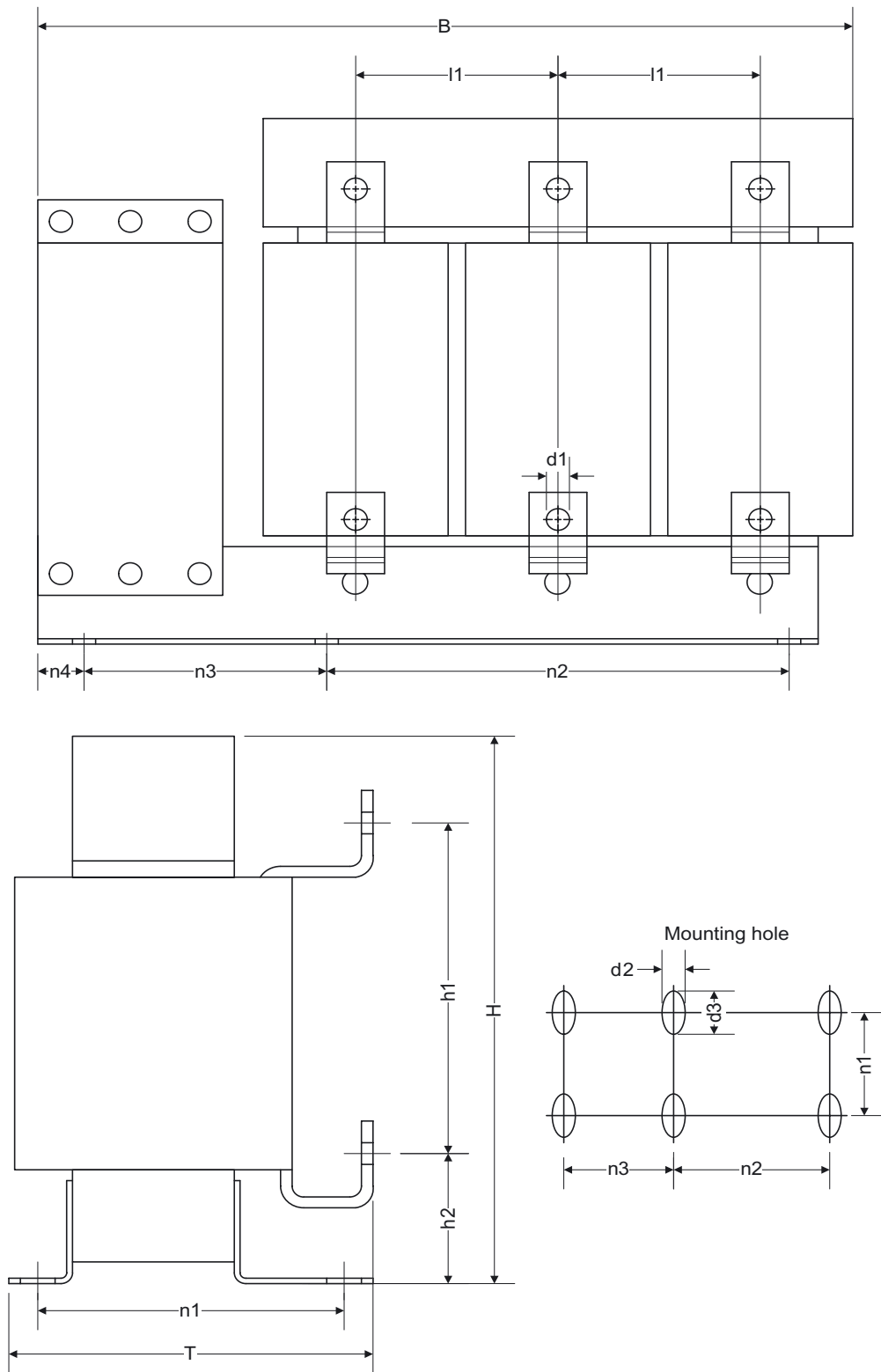

Figure 5-12 Dimension drawing, sinusoidal filter

Table 5-16 Dimensions of the sinusoidal filters, all data in mm and (inches)

6SL3000-	2CE32-3AA0	2CE32-8AA0	2CE33-3AA0	2CE34-1AA0
B	620 (24.40)	620 (24.40)	620 (24.40)	620 (24.40)
H	320 (12.59)	320 (12.59)	360 (14.17)	360 (14.17)
T	300 (11.81)	300 (11.81)	370 (14.56)	370 (14.56)
l1	140 (5.51)	140 (5.51)	140 (5.51)	140 (5.51)
h1	180 (7.08)	180 (7.08)	220 (8.66)	220 (8.66)
h2	65 (3.34)	65 (3.34)	65 (3.34)	65 (3.34)
n1 <sup>1)</sup>	280 (11.02)	280 (11.02)	320 (12.59)	320 (12.59)
n2 <sup>1)</sup>	150 (5.90)	150 (5.90)	150 (5.90)	150 (5.90)
n3 <sup>1)</sup>	225 (8.85)	225 (8.85)	225 (8.85)	225 (8.85)
n4	105 (4.13)	105 (4.13)	105 (4.13)	105 (4.13)
d1	12 (0.47)	12 (0.47)	12 (0.47)	12 (0.47)
d2	11 (0.43)	11 (0.43)	11 (0.43)	11 (0.43)
d3	22 (0.86)	22 (0.86)	22 (0.86)	22 (0.86)

1) The lengths n1, n2 and n3 correspond to the drill hole spacing

### 5.2.1.4 Technical data

Table 5-17 Technical data, sinusoidal filter

Order No.	6SL3000-	2CE32-3AA0	2CE32-3AA0	2CE32-8AA0	2CE33-3AA0	2CE34-1AA0
Suitable for Power Module	6SL3310-	1TE32-1AA0	1TE32-6AA0	1TE33-1AA0	1TE33-8AA0	1TE35-0AA0
Power rating of the Power Module at a 4 kHz pulse frequency	kW	90	110	132	160	200
Output current at a 4 kHz pulse frequency	A	225	225	276	333	408
Power loss - at 50 Hz - at 100 Hz	kW kW	0.35 0.6	0.35 0.6	0.4 0.69	0.245 0.53	0.38 0.7
Connections - to the Power Module - to the load		M10 connecting lugs M10 connecting lugs				
Degree of protection		IP 00	IP 00	IP 00	IP 00	IP 00
Dimensions						
Width	mm	620	620	620	620	620
Height	mm	300	300	300	370	370
Depth	mm	320	320	320	360	360
Weight, approx.	kg	124	124	127	136	198

## 5.3 dv/dt filter

### 5.3.1 Chassis

#### 5.3.1.1 Description

The dv/dt filter plus VPL (Voltage Peak Limiter) consists of two components: the dv/dt reactor and the voltage limiting network (Voltage Peak Limiter), which limits voltage peaks and returns the energy to the DC link.

The dv/dt filter plus VPL is to be used for motors for which the voltage strength of the insulation system is unknown or insufficient. Standard motors of the 1LA5, 1LA6 and 1LA8 series only require them at supply voltages > 500 V +10%.

The dv/dt filter plus VPL limits the rate of voltage rise to values < 500 V/μs and the typical voltage peaks at rated line voltages to the values below (with motor cable lengths < 150 m):  
 < 1000 V at  $V_{line} < 575$  V.

#### Components

The Order Nos. of the individual components (dv/dt reactor and voltage limiting network) are listed in the following table:

Table 5-18 dv/dt filter plus VPL, Order Nos. of the individual components

dv/dt filter plus VPL	dv/dt reactor	Voltage limiting network
6SL3000-2DE32-6AA0	6SL3000-2DE32-6CA0	6SL3000-2DE32-6BA0
6SL3000-2DE35-0AA0	6SL3000-2DE35-0CA0	6SL3000-2DE35-0BA0

#### 5.3.1.2 Safety information



##### Caution

The cooling clearances of 100 mm above and below the components must be observed.

##### Note

The connecting cables to the Motor Module must be kept as short as possible (max. 5 m).



---

**Caution**

The terminals must be correctly connected:

- dv/dt reactor
  - Incoming cable to the Motor Modules 1U1, 1V1, 1W1, and
  - outgoing cable to the load 1U2, 1V2, 1W2.
- Voltage limiting network (Voltage Peak Limiter - VPL)
  - Cable from the DC link to the Motor Module at DCPS, DCNS and
  - cable to the dv/dt reactor 1U2, 1V2, 1W2.

If this is not observed, then there is a danger of damage to the dv/dt reactor and the voltage limiting network.

---

---

**Caution**

When using dv/dt filters that SIEMENS has not approved for SINAMICS, then these dv/dt filters can be thermally damaged.

---



---

**Caution**

The surface temperature of the dv/dt reactors may exceed 80 °C.

---

---

**Caution**

The maximum permissible output frequency when using dv/dt filters is 150 Hz.

---

5.3.1.3 Interface description

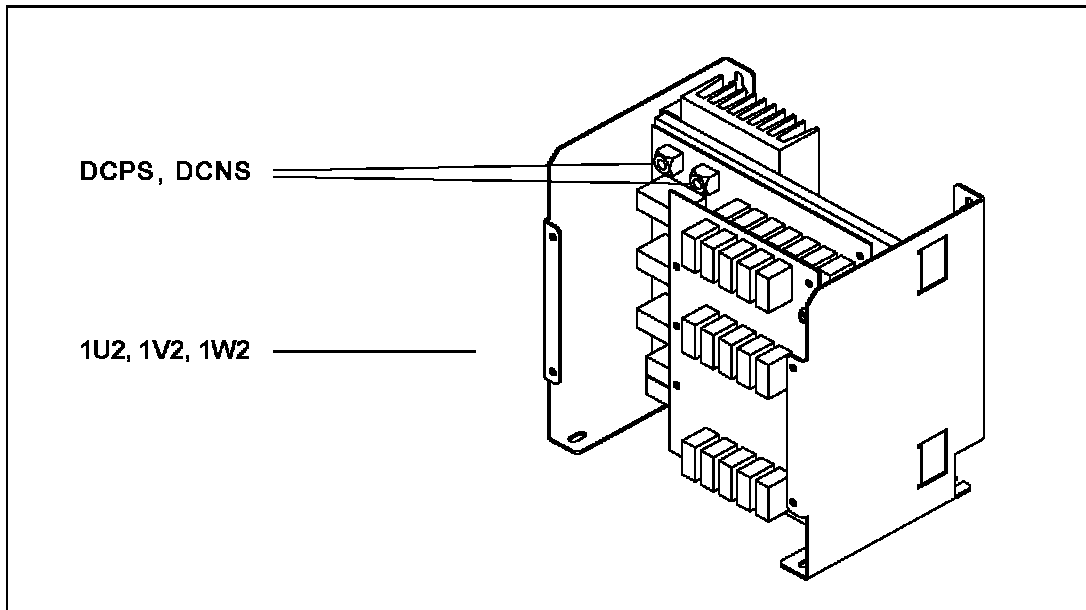

Figure 5-13 Interface overview, voltage limiting network, type 1

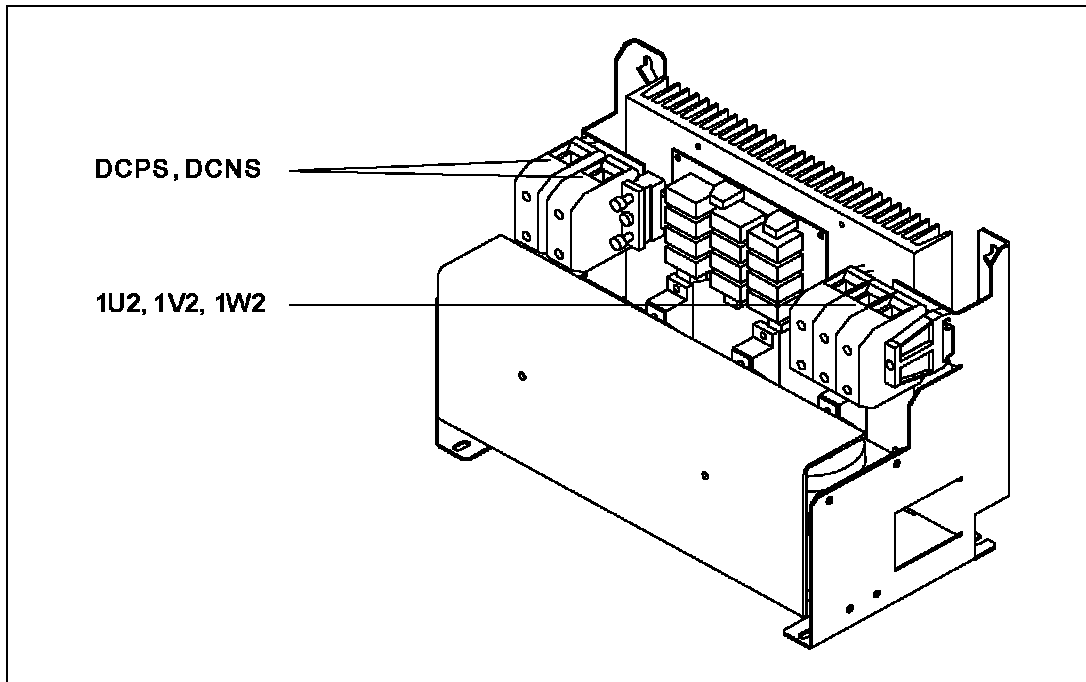

Figure 5-14 Interface overview, voltage limiting network, type 2

5.3.1.4 Connection of the dv/dt filter

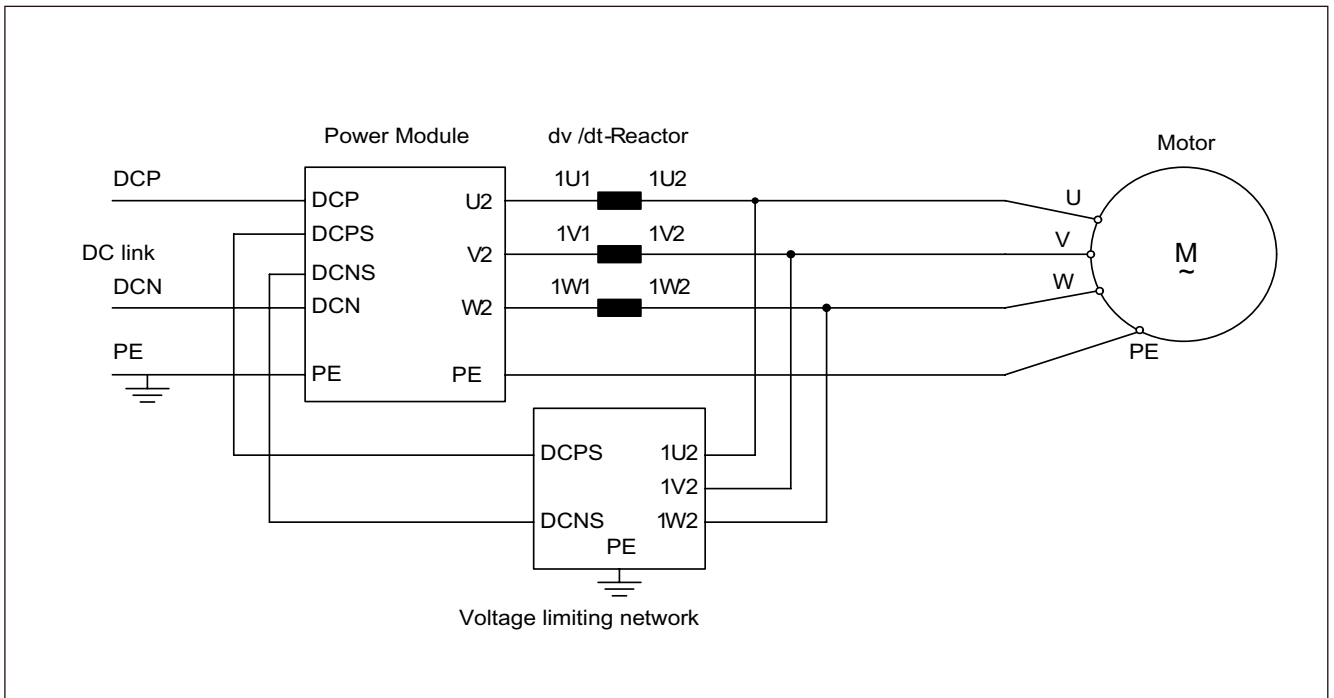

Figure 5-15 Connection of the dv/dt filter

Cable cross-sections

Table 5-19 Cable cross-sections for connected between a dv/dt filter and Power Module

dv/dt filter plus VPL	Connection to the DC link (DCPS / DCNS) [mm <sup>2</sup> ]	Connection between a dv/dt reactor and voltage limiting network (1U2, 1V2, 1W2) [mm <sup>2</sup> ]
6SL3000-2DE32-6AA0	35	10
6SL3000-2DE35-0AA0	70	16

**Note**

The connections should be kept as short as possible.

The maximum cable length for the specified connections is 5 m.

5.3.1.5 Dimension drawing, dv/dt reactor

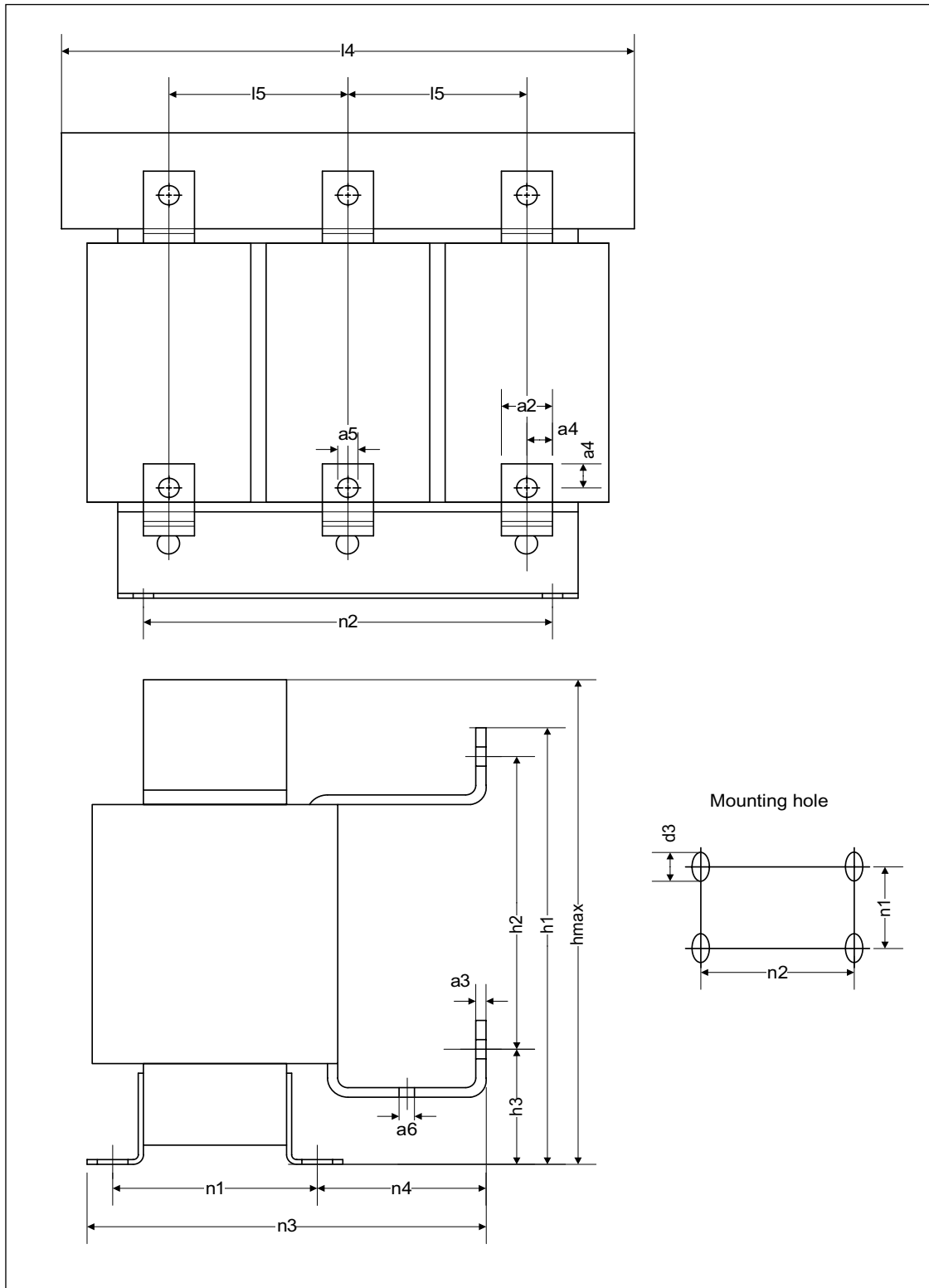

Figure 5-16 Dimension drawing, dv/dt reactor

Table 5-20 Dimensions dv/dt reactor, 3-ph. 380 V – 480 V AC, all data in mm and (inches)

<b>6SL3000-</b>	<b>2DE32-6CA0</b>	<b>2DE35-0CA0</b>
a2	25 (0.98)	30 (1.18)
a3	5 (0.19)	6 (0.23)
a4	14 (0.55)	17 (0.66)
a5	10.5 x 14 (0.41 x 0.55)	14 x 18 (0.55 x 0.70)
a6	7 (0.27)	9 (0.35)
a7	-	-
a8	-	-
l4	410 (16.14)	460 (18.11)
l5	135 (5.31)	152.5 (6.00)
hmax	370 (14.56)	370 (14.56)
h2	258 (10.15)	240 (9.44)
h3	76 (2.99)	83 (3.26)
n1 <sup>1)</sup>	141 (5.55)	182 (7.16)
n2 <sup>1)</sup>	316 (12.44)	356 (14.01)
n3	229 (9.01)	275 (10.82)
n4	72 (2.83)	71 (2.79)
d3	M10 [12 x 18] (0.47 x 0.70)	M12 [15 x 22] (0.59 x 0.86)
<sup>1)</sup> Lengths n1 and n2 correspond to the distance between holes		

5.3.1.6 Dimension drawing, limiting network

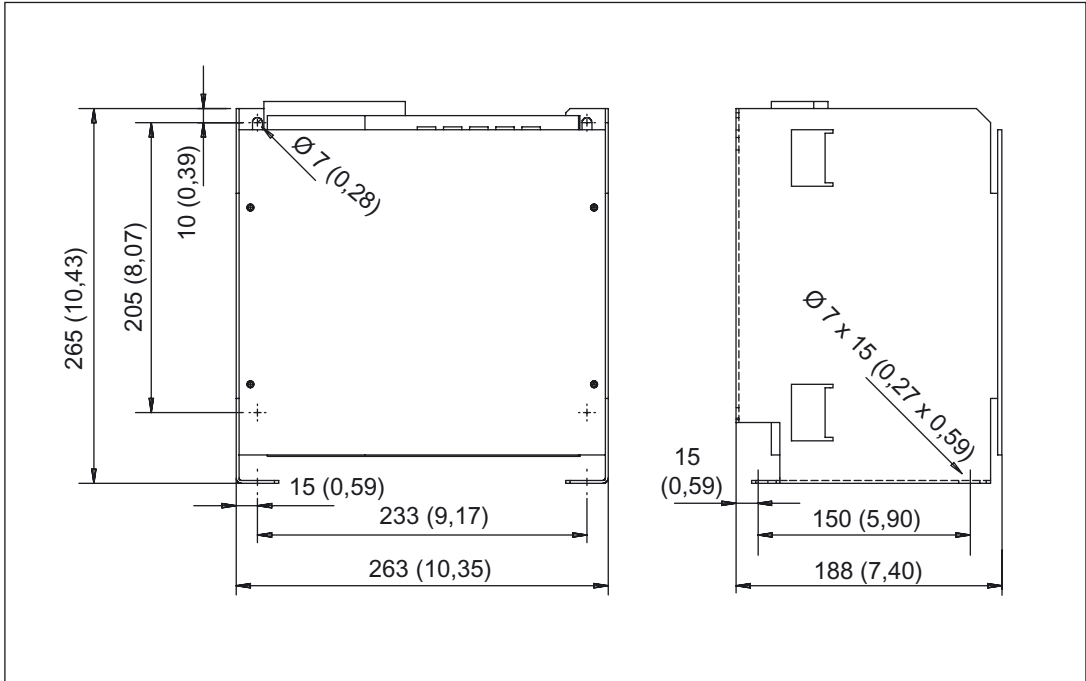

Figure 5-17 Dimension drawing, voltage limiting network, type 1

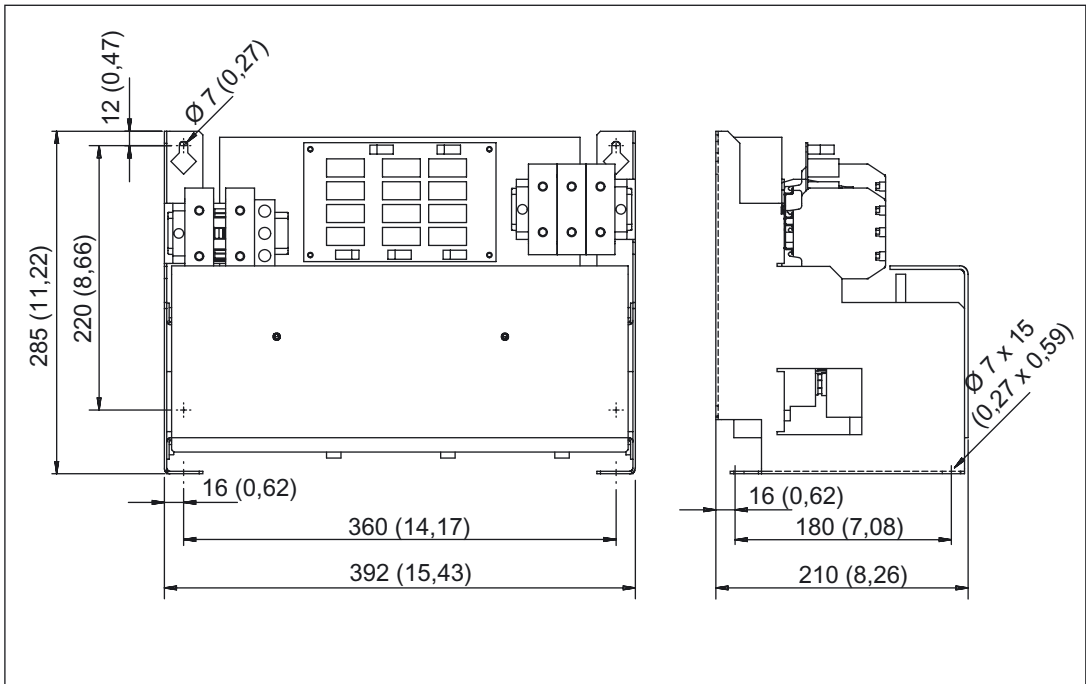

Figure 5-18 Dimension drawing, voltage limiting network, type 2

Table 5-21 Assigning voltage limiting networks to dimension drawings

Voltage limiting network	Dimension drawing, type
6SL3000-2DE32-6BA0	Type 1
6SL3000-2DE35-0BA0	Type 2

### 5.3.1.7 Technical data

Table 5-22 Technical data, dv/dt filter plus VPL, 3-ph. 380 V – 480 V AC, Part 1

Order No.	6SL3000-	2DE32-6AA0	2DE32-6AA0	2DE35-0AA0
Suitable for Motor Module	6SL3310-	1TE32-1AA0	1TE32-6AA0	1TE33-1AA0
Rated power of Motor Module	kW	110	132	160
dv/dt reactor				
$I_{thmax}$	A	260	260	490
Power loss, typical	kW	0.573	0.573	0.696
Connections - to the Motor Module - load - PE		M10 M10 M6	M10 M10 M6	M12 M12 M6
Max. permissible cable length between dv/dt reactor and motor	m	300 (shielded) 450 (non-shielded)		
Degree of protection		IP00	IP00	IP00
Dimensions				
Width	mm	410	410	460
Height	mm	370	370	370
Depth	mm	229	229	275
Weight, approx.	kg	66	66	122
Voltage limiting network (Voltage Peak Limiter - VPL)				
$I_{thmax}$	A	260	260	490
Power loss, typical	kW	0.029	0.029	0.042
Connections - to the dv/dt reactor - DC - PE		M8 M8 M??	M8 M8 M??	Terminal 70 mm <sup>2</sup> Terminal 70 mm <sup>2</sup> Terminal 35 mm <sup>2</sup>
Degree of protection		IP00	IP00	IP00
Dimensions				
Width	mm	265	265	400
Height	mm	265	265	285
Depth	mm	190	190	210
Weight, approx.	kg	6	6	16

5.3 dv/dt filter

Table 5-23 Technical data, dv/dt filter plus VPL, 3-ph. 380 V – 480 V AC, Part 2

Order No.	6SL3000-	2DE35-0AA0	2DE35-0AA0	2DE35-0AA0
Suitable for Motor Module	6SL3310-	1TE33-8AA0	1TE35-0AA0	1TE35-0AA0
Rated power of Motor Module	kW	200	250	250
dv/dt reactor				
$I_{thmax}$	A	490	490	490
Power loss, typical	kW	0.696	0.696	0.696
Connections - to the Motor Module - load - PE		M12 M12 M6	M12 M12 M6	M12 M12 M6
Max. permissible cable length between dv/dt reactor and motor	m	300 (shielded) 450 (non-shielded)		
Degree of protection		IP00	IP00	IP00
Dimensions				
Width	mm	460	460	460
Height	mm	370	370	370
Depth	mm	275	275	275
Weight, approx.	kg	122	122	122
Voltage limiting network (Voltage Peak Limiter - VPL)				
$I_{thmax}$	A	490	490	490
Power loss, typical	kW	0.042	0.042	0.042
Connections - to the dv/dt reactor - DC - PE		Terminal 70 mm <sup>2</sup> Terminal 70 mm <sup>2</sup> Terminal 35 mm <sup>2</sup>	Terminal 70 mm <sup>2</sup> Terminal 70 mm <sup>2</sup> Terminal 35 mm <sup>2</sup>	Terminal 70 mm <sup>2</sup> Terminal 70 mm <sup>2</sup> Terminal 35 mm <sup>2</sup>
Degree of protection		IP00	IP00	IP00
Dimensions				
Width	mm	400	400	400
Height	mm	285	285	285
Depth	mm	210	210	210
Weight, approx.	kg	16	16	16



## Control Units

### 6.1 Introduction

#### Description

The Control Units of SINAMICS S120 AC Drive are designed for use with Blocksize format or Chassis format Power Modules.

#### Advantages

1. The control module **CU310 DP** provides the external communications interface PROFIBUS and a TTL/HTL encoder evaluation.
2. The control module **CU310 PN** has two PROFINET interfaces (ports).
3. Power modules can also be connected to the multi-axis Control Unit using the adapter module **CUA31**. The combination of a modular power unit and a Control Unit Adapter 31 (CUA31) is used to extend an existing DC/AC drive line-up with Control Unit by one axis.

---

#### Note

The firmware and parameter settings are stored on the CompactFlash card, which is plugged into the CU310 Control Unit.

---



Control Unit 310 DP



Control Unit 310 PN



Control Unit Adapter 31 (CUA31)

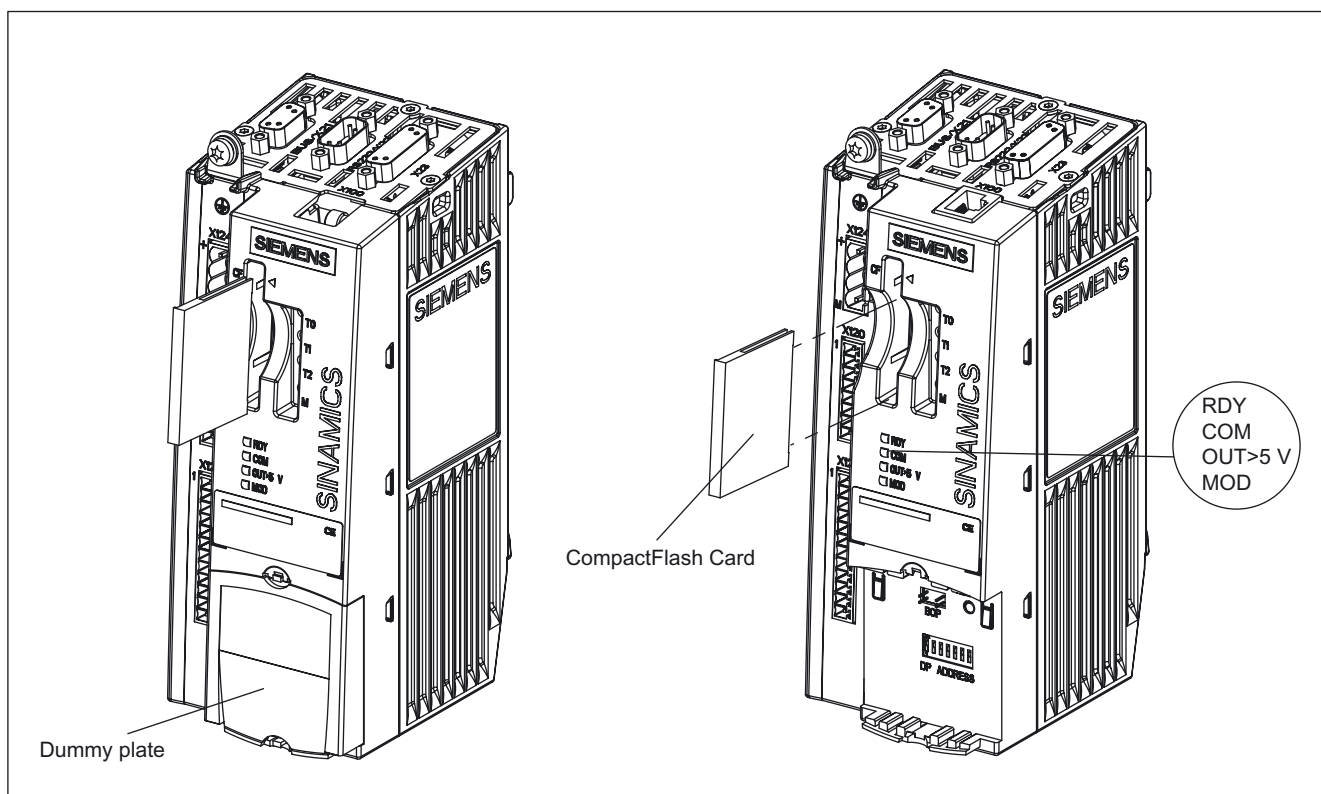

Figure 6-1 Overview, Control Unit 310 DP (CU310 DP)

**Note**

The Control Unit and the CompactFlash card must be ordered separately.

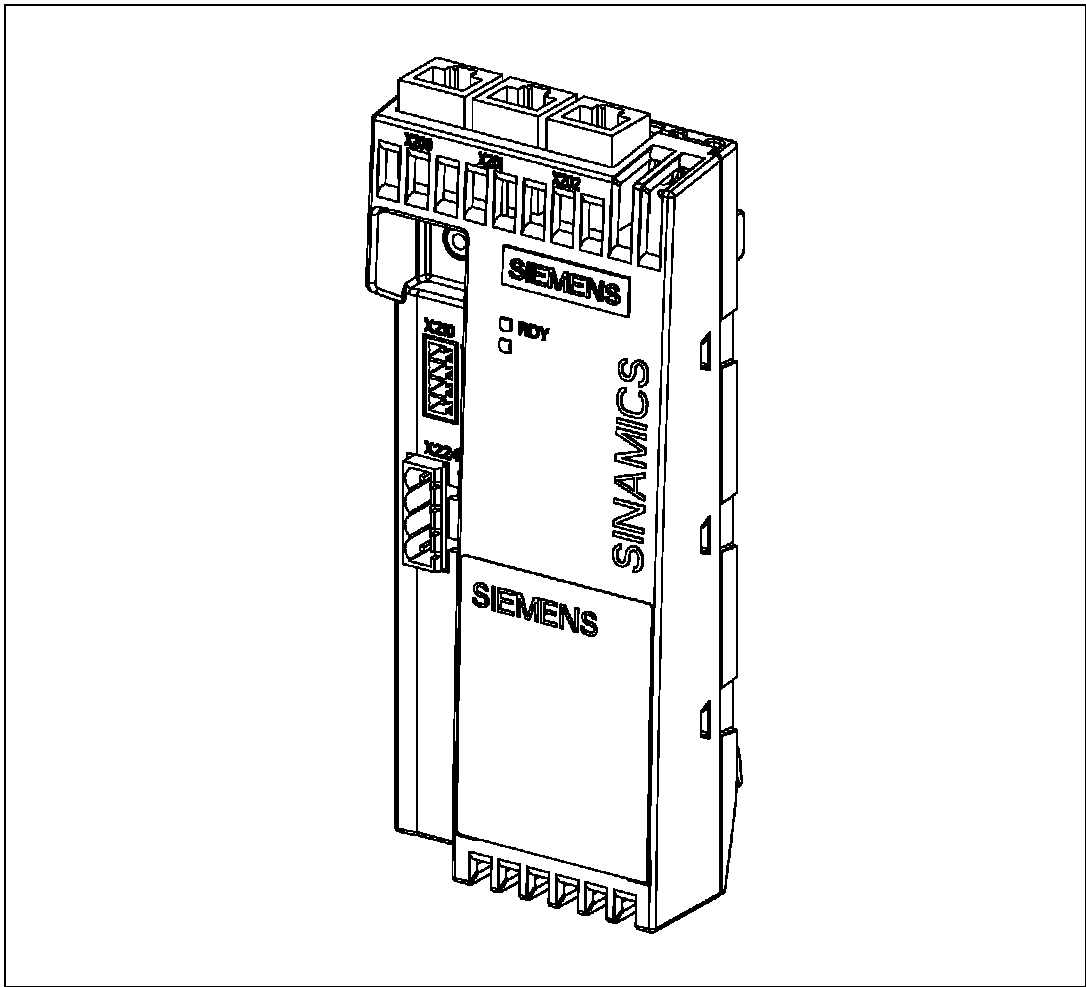

Figure 6-2 Overview, Control Unit Adapter 31 (CUA31)

## 6.2 Control Unit CU310 DP (PROFIBUS)

### 6.2.1 Description

The Control Unit 310 DP (PROFIBUS) is the component in which the open-loop and closed-loop control functions of a drive are implemented.

The CU310 DP has the following interfaces (ports):

Table 6-1 Overview of the CU310 interfaces

Type	Number
Digital inputs	4
Digital inputs/outputs	4
DRIVE-CLiQ interfaces	1
PROFIBUS interface	1
Serial interface (RS232)	1
Power Module Interface (PM-IF)	1
Encoder interface (HTL/TTL)	1
EP terminals/ temperature sensor connection	1
24 V electronics power supply	1
Test sockets	3+1
Interface for BOP	1

---

#### Note

For test purposes, the fan also runs in the cold state at regular intervals.

---

## 6.2.2 Safety information

---

### Note

The CompactFlash card may only be inserted and removed from the Control Unit when in the no-voltage condition.

---



---

### Caution

The cooling clearances of 50 mm above and below the components must be observed. It is not permissible that the connecting cables cover the cooling openings.

---

## 6.2.3 Interface description

### 6.2.3.1 Overview

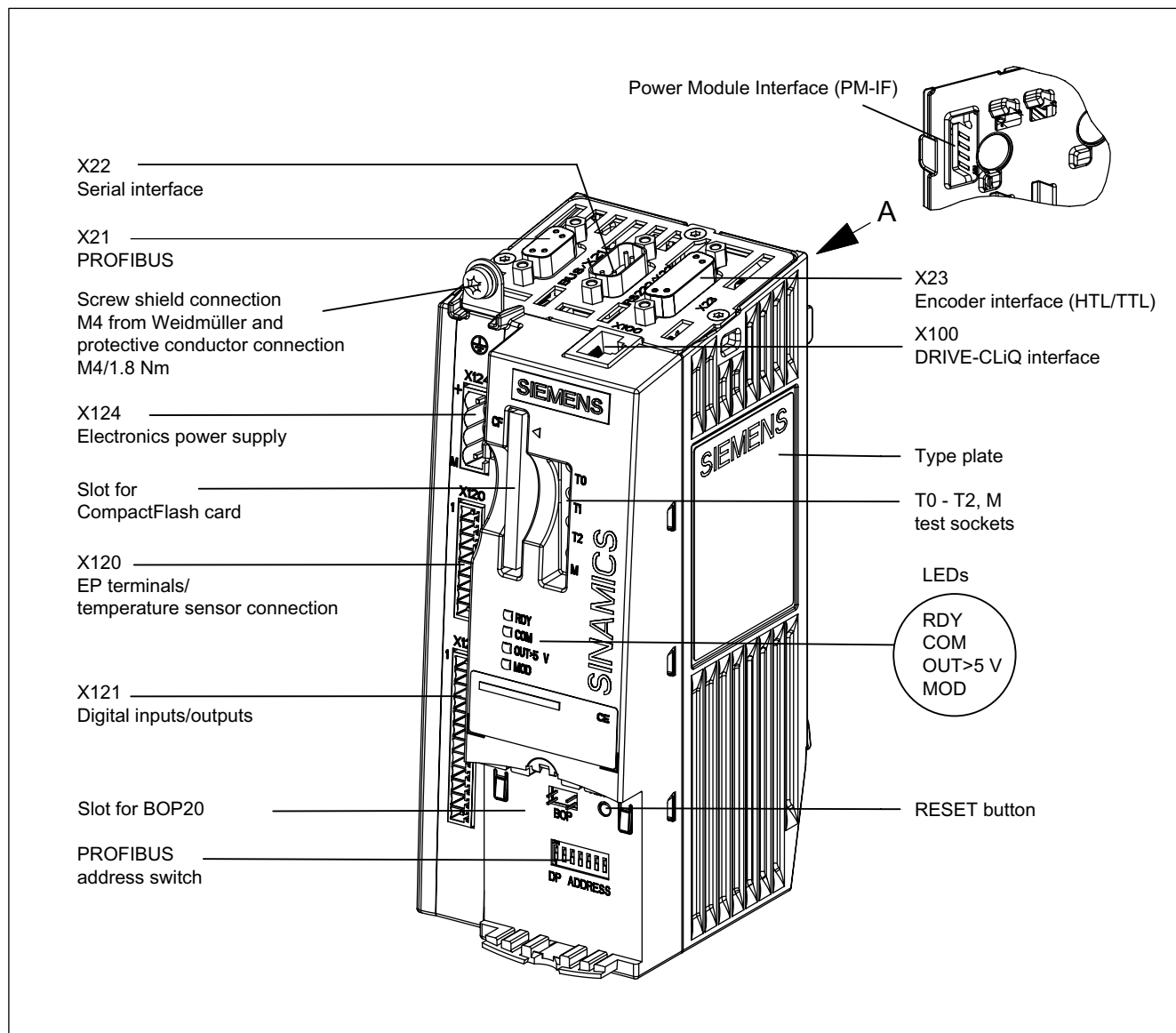

Figure 6-3 Description of the CU310 DP interfaces (ports)

6.2.3.2 Sample connection

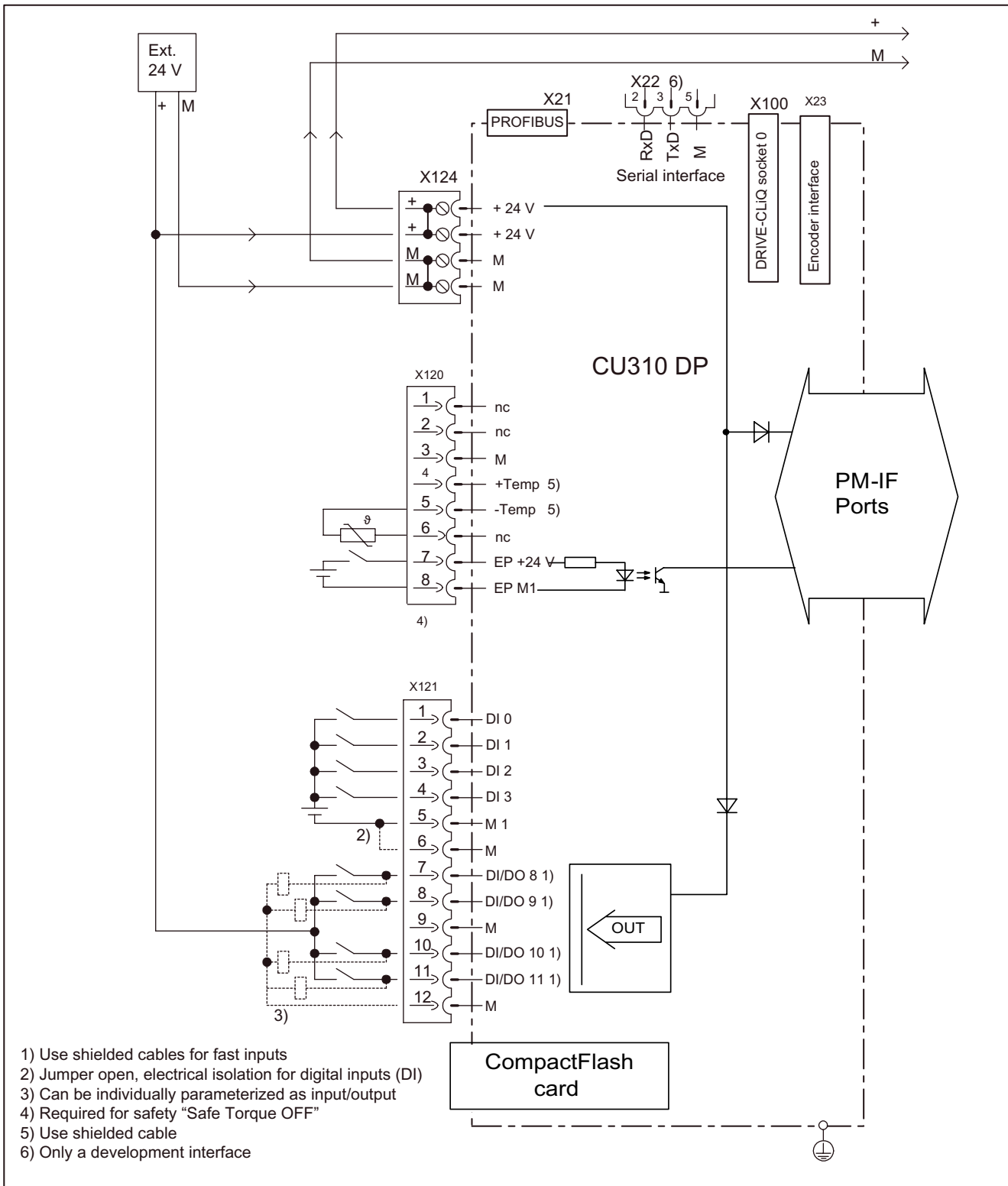
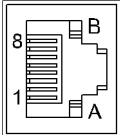

Figure 6-4 Connection example CU310 DP



### 6.2.3.3 X100 DRIVE-CLiQ interface

Table 6-2 DRIVE-CLiQ interface

	Pin	Signal name	Technical specifications
	1	TXP	Transmit data +
	2	TXN	Transmit data -
	3	RXP	Receive data +
	4	Reserved, do not use	
	5	Reserved, do not use	
	6	RXN	Receive data -
	7	Reserved, do not use	
	8	Reserved, do not use	
	A	+ (24 V)	Power supply
	B	GND (0 V)	Electronic ground
Blanking plate for DRIVE-CLiQ interface: Molex, order number: 85999-3255			
The maximum DRIVE-CLiQ cable length is 50 m.			

### 6.2.3.4 X120 EP terminals / temperature sensor connection

Table 6-3 Terminal strip X120

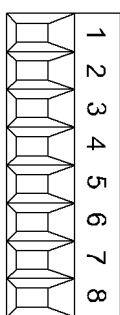
	Terminal	Function	Technical specifications
	1	Reserved, do not use	
	2	Reserved, do not use	
	3	M	Ground
	4	+Temp	KTY or PTC input
	5	-Temp	Ground for KTY or PTC
	6	Reserved, do not use	
	7	EP +24 V	Safe standstill input (+)
	8	EP M1	Safe standstill input (-)
Max. cross-section that can be connected 1.5 mm <sup>2</sup>			

#### Notice

The KTY temperature sensor/the PTC must be connected with the correct polarity.

6.2.3.5 X121 digital inputs/outputs

Table 6-4 Terminal strip X121

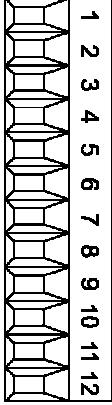
	Terminal	Designation <sup>1)</sup>	Technical specifications
	1	DI 0	Voltage: -3 V to 30 V Typical current consumption: 10 mA at 24 V DC Isolation: The reference potential is terminal M1 Level (incl. ripple) High level: 15 V to 30 V Low level: -3 V to 5 V Signal propagation times: L → H approx. 50 µs H → L: approx. 100 µs
	2	DI 1	
	3	DI 2	
	4	DI 3	
	5	M1	
	6	M	
	7	DI/DO 8	As input: Voltage: -3 V to 30 V Typical current consumption: 10 mA at 24 V DC Level (incl. ripple) High level: 15 V to 30 V Low level: -3 V to 5 V Terminal numbers 8, 10, and 11 are "fast inputs" Signal propagation times for inputs/"fast inputs": L → H: approx. 50 µs/5 µs H → L: approx. 100 µs/50 µs As output: Voltage: 24 V DC Max. load current per output: 500 mA Continued-short-circuit-proof
	8	DI/DO 9	
	9	M	
	10	DI/DO 10	
	11	DI/DO 11	
	12	M	
Max. cross-section that can be connected: 1.5 mm <sup>2</sup> Type: Spring-loaded terminal 1 (see Appendix A)			

1) DI: digital input; DI/DO: Bidirectional digital input/output; M: Electronic ground M1: Ground reference

**Notice**

An open input is interpreted as "low".

The "fast inputs" can be used in conjunction with a measuring system for position sensing.

To enable digital inputs (DI) 0 to 3 to function, terminal M1 must be connected. This can be done as follows:

Connect the digital inputs' ground reference, or a jumper to terminal M. This removes the electrical isolation for these digital inputs.

**Note**

An external 24 V power supply is required.

If a the 24 V power supply voltage is briefly interrupted, then the digital outputs are de-activated during this time.

### 6.2.3.6 Electronics power supply X124

Table 6-5 Terminal block X124

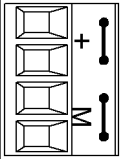
	Terminal	Function	Technical specifications
	+	Electronics power supply	Voltage: 24 V DC (20.4 V - 28.8 V) Current consumption: max. 0.8 A (without DRIVE-CLiQ or digital outputs) Max. current via jumper in connector: 20 A at 55 °C
	+	Electronics power supply	
	M	Electronic ground	
	M	Electronic ground	
Max. cross-section that can be connected: 2.5 mm <sup>2</sup> Type: Screw terminal 2 (see Appendix A)			

#### Note

The two “+” and “M” terminals are jumpered in the connector. This ensures the supply voltage is looped through.

The current consumption increases by the value for the DRIVE-CLiQ node.

### 6.2.3.7 X21 PROFIBUS

Table 6-6 PROFIBUS interface X21

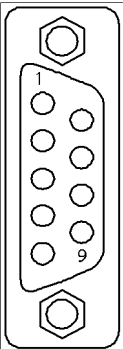
	Pin	Signal name	Meaning	Range
	1	-	Do not use	
	2	M24_SERV	Power supply for teleservice, ground	0 V
	3	RxD/TxD-P	Receive/transmit data P (B)	RS485
	4	CNTR-P	Control signal	TTL
	5	DGND	PROFIBUS data reference potential	
	6	VP	Supply voltage plus	5 V + -10 %
	7	P24_SERV	Power supply for teleservice, + (24 V)	24 V (20.4 V - 28.8 V)
	8	RxD/TxD-N	Receive/transmit data N (A)	RS485
	9	-	Do not use	
Type: 9-pin SUB-D female				

**Note**

A teleservice adapter can be connected to the PROFIBUS interface (X21) for remote diagnosis purposes.

The power supply for the teleservice terminals 2 and 7 withstands a max. load and continued short-circuit current of 150 mA.

**PROFIBUS connector**

At the first and last node (device) in a line, the terminating resistors must be switched-in in order to ensure disturbance/noise-free communications.

The terminating resistors are activated in the connector.

The cable shield must be connected at both ends over large-surface area contacts.

**6.2.3.8 X23 HTL/ TTL encoder interface**

Table 6-7 Encoder connection X23

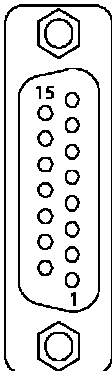
	Pin	Signal name	Technical specifications
	1	Reserved, do not use	
	2	SSI_CLK	SSI clock, positive
	3	SSI_XCLK	SSI clock, negative
	4	PENC	Encoder power supply
	5	PENC	Encoder power supply
	6	PSENSE	Remote sense encoder power supply (P)
	7	M	Electronic ground
	8	Reserved, do not use	
	9	MSENSE	Remote sense encoder power supply (N)
	10	RP	R track positive
	11	RN	R track negative
	12	BN	B track negative
	13	BP	B track positive
	14	AN_SSI_XDAT	A track negative / SSI data negative
	15	AP_SSI_DAT	A track positive / SSI data positive

Type: 15-pin SUB D connector

### 6.2.3.9 PROFIBUS address switches

Table 6-8 PROFIBUS address switches

Technical specifications	Switch	Significance																																																	
Significance: <table style="display: inline-table; vertical-align: middle;"> <tr> <td><math>2^0</math></td><td><math>2^1</math></td><td><math>2^2</math></td><td><math>2^3</math></td><td><math>2^4</math></td><td><math>2^5</math></td><td><math>2^6</math></td> </tr> <tr> <td>1</td><td>2</td><td>4</td><td>8</td><td>16</td><td>32</td><td>64</td> </tr> <tr> <td><input type="checkbox"/></td><td><input type="checkbox"/></td><td><input type="checkbox"/></td><td><input type="checkbox"/></td><td><input type="checkbox"/></td><td><input type="checkbox"/></td><td><input type="checkbox"/></td> </tr> <tr> <td><input type="checkbox"/></td><td><input type="checkbox"/></td><td><input type="checkbox"/></td><td><input type="checkbox"/></td><td><input type="checkbox"/></td><td><input type="checkbox"/></td><td><input type="checkbox"/></td> </tr> <tr> <td>S1</td><td>S2</td><td>S3</td><td>S4</td><td>S5</td><td>S6</td><td>S7</td> </tr> </table> ON OFF Example: <table style="display: inline-table; vertical-align: middle;"> <tr> <td>1</td><td>+</td><td>4</td><td>+</td><td>32</td><td>=</td><td>37</td> </tr> <tr> <td colspan="6">PROFIBUS address</td><td>= 37</td> </tr> </table>	$2^0$	$2^1$	$2^2$	$2^3$	$2^4$	$2^5$	$2^6$	1	2	4	8	16	32	64	<input type="checkbox"/>	<input type="checkbox"/>	<input type="checkbox"/>	<input type="checkbox"/>	<input type="checkbox"/>	<input type="checkbox"/>	<input type="checkbox"/>	<input type="checkbox"/>	<input type="checkbox"/>	<input type="checkbox"/>	<input type="checkbox"/>	<input type="checkbox"/>	<input type="checkbox"/>	<input type="checkbox"/>	S1	S2	S3	S4	S5	S6	S7	1	+	4	+	32	=	37	PROFIBUS address						= 37	S1	$2^0 = 1$
	$2^0$	$2^1$	$2^2$	$2^3$	$2^4$	$2^5$	$2^6$																																												
	1	2	4	8	16	32	64																																												
	<input type="checkbox"/>	<input type="checkbox"/>	<input type="checkbox"/>	<input type="checkbox"/>	<input type="checkbox"/>	<input type="checkbox"/>	<input type="checkbox"/>																																												
	<input type="checkbox"/>	<input type="checkbox"/>	<input type="checkbox"/>	<input type="checkbox"/>	<input type="checkbox"/>	<input type="checkbox"/>	<input type="checkbox"/>																																												
	S1	S2	S3	S4	S5	S6	S7																																												
	1	+	4	+	32	=	37																																												
PROFIBUS address						= 37																																													
	S2	$2^1 = 2$																																																	
	S3	$2^2 = 4$																																																	
	S4	$2^3 = 8$																																																	
	S5	$2^4 = 16$																																																	
	S6	$2^5 = 32$																																																	
	S7	$2^6 = 64$																																																	

#### Note

The PROFIBUS address switches are defaulted to 0 or 127. In these two settings, addresses are assigned via parameters.

The address switch is behind the blanking plate. The blanking plate is part of the scope of supply.

#### Setting the PROFIBUS address

The following reference contains further information about setting the PROFIBUS address:

Reference: /IH1/ SINAMICS S120 Commissioning Manual.

6.2.3.10 X22 serial interface (RS232)

Table 6-9 Serial interface (RS-232-C) X140

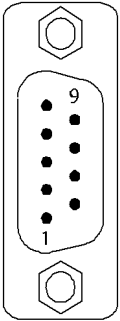
	Pin	Designation	Technical data
	2	RxD	Receive data
	3	TxD	Transmit data
	5	Ground	Ground reference
Type: 9-pin SUB D connector			

6.2.3.11 Measurement sockets T0, T1, and T2

Table 6-10 Measurement sockets T0, T1, and T2

Socket	Function	Technical specifications
T0	Measurement socket 0	Voltage: 0 V to 5 V Resolution: 8 bits Load current: max. 3 mA Continued-short-circuit-proof
T1	Measurement socket 1	
T2	Measurement socket 2	
M	Ground	The reference potential is terminal M
The measurement sockets are only suitable for bunch pin plugs with a diameter of 2 mm.		

### 6.2.3.12 Slot for the CompactFlash card



Figure 6-5 Slot for CompactFlash card

---

#### Caution

The CompactFlash card may only be inserted as shown in the figure (arrow top right).

The CompactFlash card may only be inserted or removed when the Control Unit is in a no-voltage condition.

When returning a defective Control Unit, remove the CompactFlash card and keep it for insertion in the replacement unit.

---

## 6.2.3.13 Description of the LEDs on the Control Unit 310 DP

Table 6-11 Description of the LEDs on the Control Unit

LED	Color	State	Description
RDY (READY)	-	Off	Electronics power supply outside permissible tolerance range
	Green	Steady light	The component is ready for operation and cyclic DRIVE-CLiQ communication is taking place.
		Flashing light 2 Hz	Writing to CompactFlash card
	Red	Steady light	At least one fault is present in this component.
		Flashing light 0.5 Hz	CompactFlash card has not been inserted. Boot error (e.g. firmware cannot be loaded to the RAM).
	Green Red	Flashing light 0.5 Hz	Control Unit 310 DP is ready for operation. No software licenses for device.
	Orange	Steady light	DRIVE-CLiQ communication is being established.
		Flashing light 0.5 Hz	Unable to load firmware to RAM
Flashing light 2 Hz		Firmware CRC error	
COM (PROFIBUS cyclic operation)	-	Off	Cyclic communication is not (yet) running. Note: The PROFIBUS is ready for communication when the Control Unit is ready for operation (see RDY LED).
	Green	Steady light	Cyclic communication is running.
		Flashing light 0.5 Hz	Cyclic communication is not yet running fully. Possible reasons: <ul style="list-style-type: none"> <li>The master is not transmitting setpoints.</li> <li>No global control (GC) or master sign-of-life is transmitted during isochronous operation.</li> </ul>
	Red	Steady light	Cyclic communication has been interrupted.
OUT > 5V	-	Off	Electronics power supply is missing or outside permissible tolerance range. Power supply $\leq 5$ V.
	Orange	Steady light	Electronics power supply for measuring system available. Power supply $> 5$ V. <b>Notice</b> You must ensure that the connected encoder can be operated with a 24 V supply. If an encoder that is designed for a 5 V supply is operated with a 24 V supply, this can destroy the encoder electronics.
MOD	--	Off	Reserved



### Cause and rectification of faults

The following reference contains information about the cause and rectification of faults:

Reference: //IH1/ SINAMICS S120 Commissioning Manual.

### RESET button

The RESET button is located behind the blanking plate.

### 6.2.4 Dimension drawing

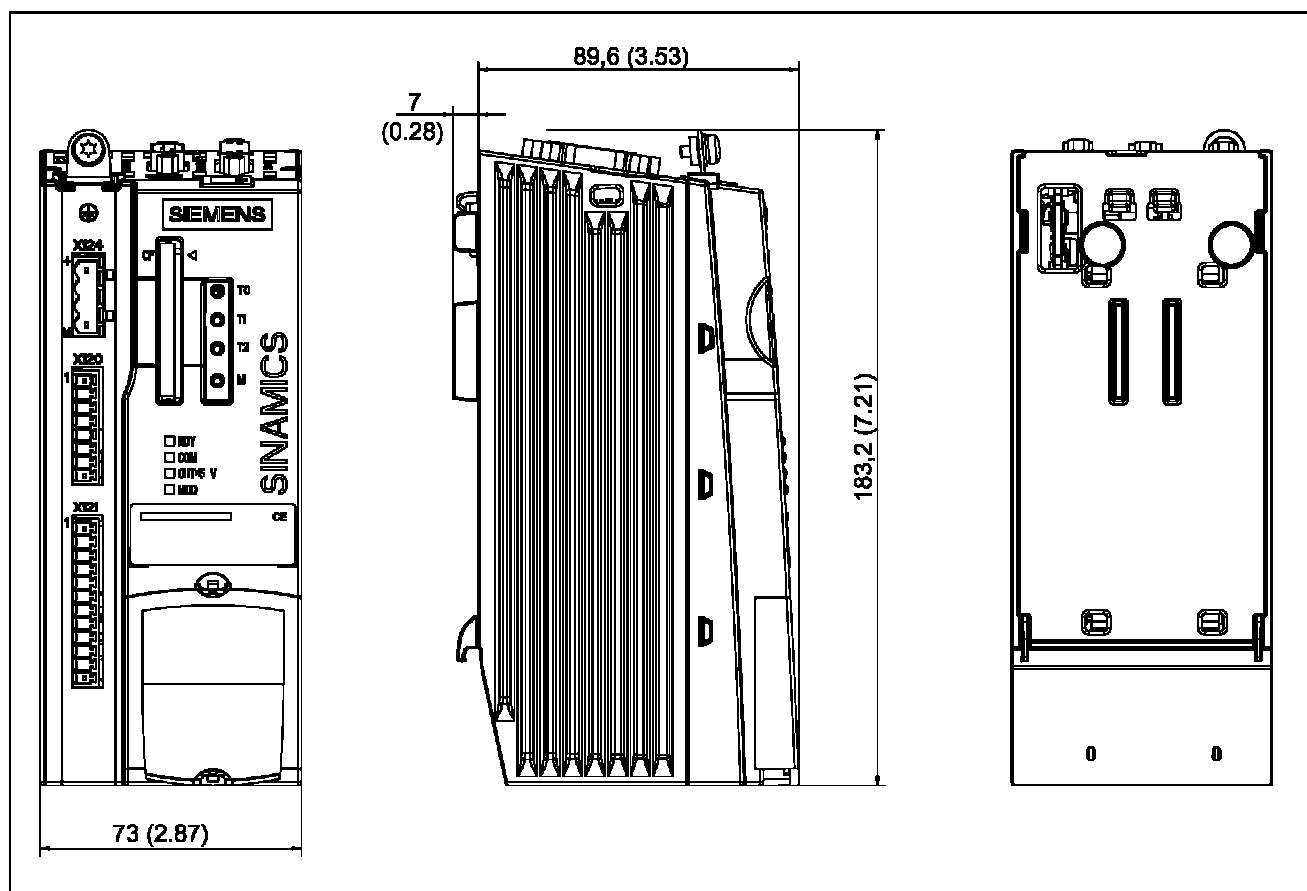
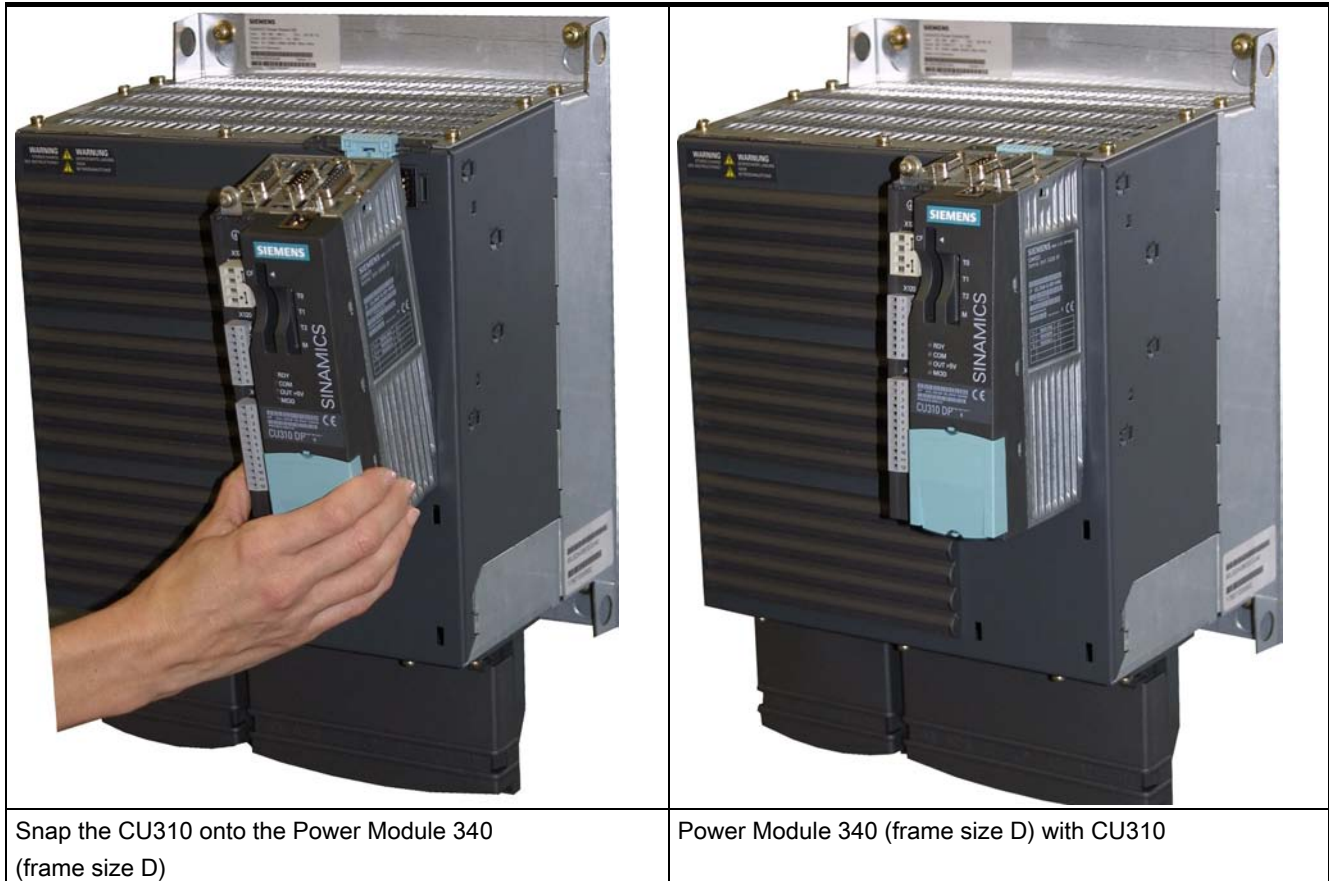

Figure 6-6 Dimension drawing CU310 DP

### 6.2.5 Mounting the CU310 on the Power Module Blocksize

As soon as the Power Module has been correctly installed, the Control Unit can be attached to the Power Module.



The procedure when mounting the Control Unit on the Power Module is independent of the frame size of the Power Modules.

## Removing the Control Unit



Removing the CU310 from the Power Module 340 (frame size D)

In order to remove the Control Unit from the Power Module, the blue release lever, as shown in the diagram, must be pressed downwards and the Control Unit swung-out to the front.

### 6.2.6 Mounting the CU310 in the Power Module Chassis

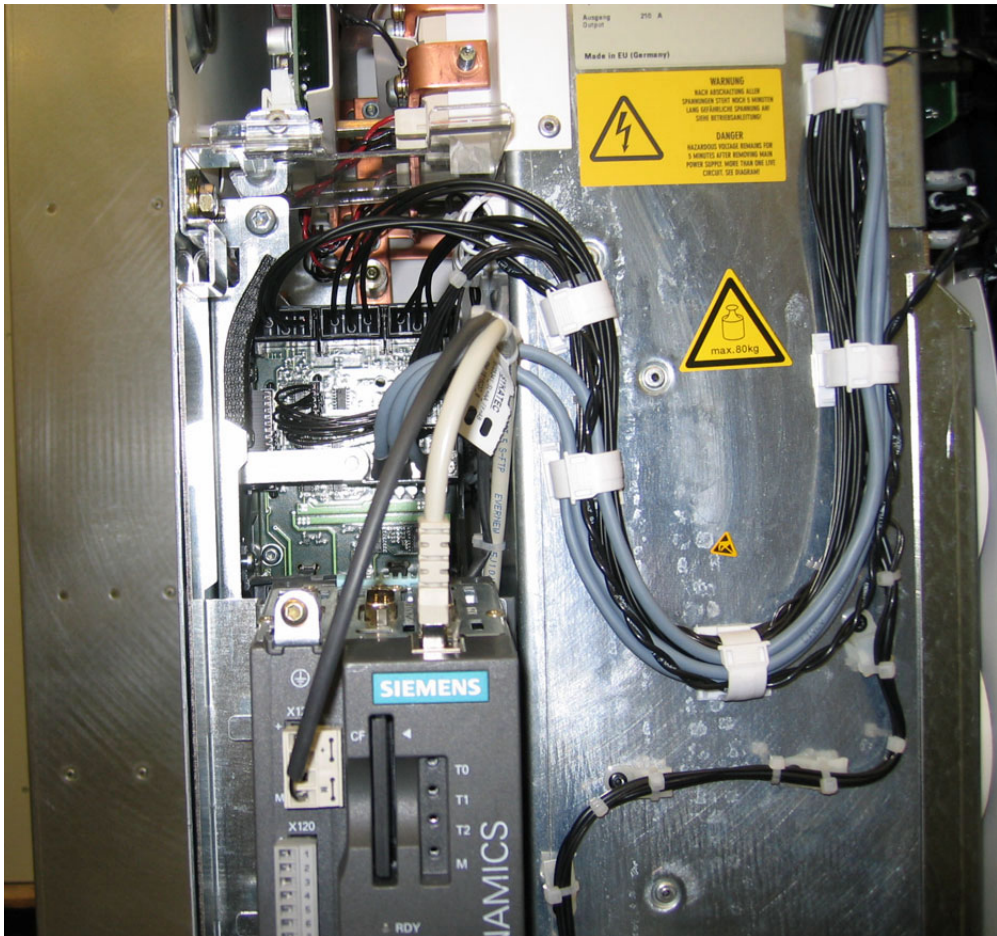

Figure 6-7 Mounting the CU310 in the Power Module Chassis, frame size FX

The DRIVE-CLiQ cable and the cable for the 24 V power supply must be correctly routed so that the front flap can close.

## 6.2.7 Technical data

Table 6-12 Technical data CU310 DP

	Unit	Value
Electronics power supply		
Voltage	V <sub>DC</sub>	DC 24 (20.4 – 28.8)
Current (without DRIVE-CLiQ and digital outputs)	A <sub>DC</sub>	0.8
Power loss	W	<20
PE/ground connection	At the housing with M4/3 Nm screw	
Response time	The response time of digital inputs/outputs depends on the evaluation (refer to the function diagram). <b>Reference:</b> /LH1/ SINAMICS S List Manual, Chapter "Function diagrams".	
Weight	kg	0.95

## 6.3 Control Unit CU310 PN (PROFINET)

### 6.3.1 Description

The Control Unit 310 PN (PROFINET) is the control module in which the open-loop and closed-loop control functions of a drive are implemented.

The CU310 PN has the following interfaces (ports):

Table 6-13 Overview of the CU310 PN interfaces (ports)

Type	Number
Digital inputs	4
Digital inputs/outputs	4
DRIVE-CLiQ interface	1
PROFINET interfaces	2
Serial interface (RS232)	1
Power Module Interface (PM-IF)	1
Encoder interface (HTL/TTL)	1
EP terminals/ temperature sensor connection	1
24 V electronics power supply	1
Test sockets	3+1
Interface for BOP	1

Available from approx. 07/2006.

### 6.3.2 Safety information

---

#### Note

The CompactFlash card may only be inserted and removed from the Control Unit when in the no-voltage condition.

---



---

#### Caution

The cooling clearances of 50 mm above and below the components must be observed. It is not permissible that the connecting cables cover the cooling openings.

---

## 6.3.3 Interface description

### 6.3.3.1 Overview

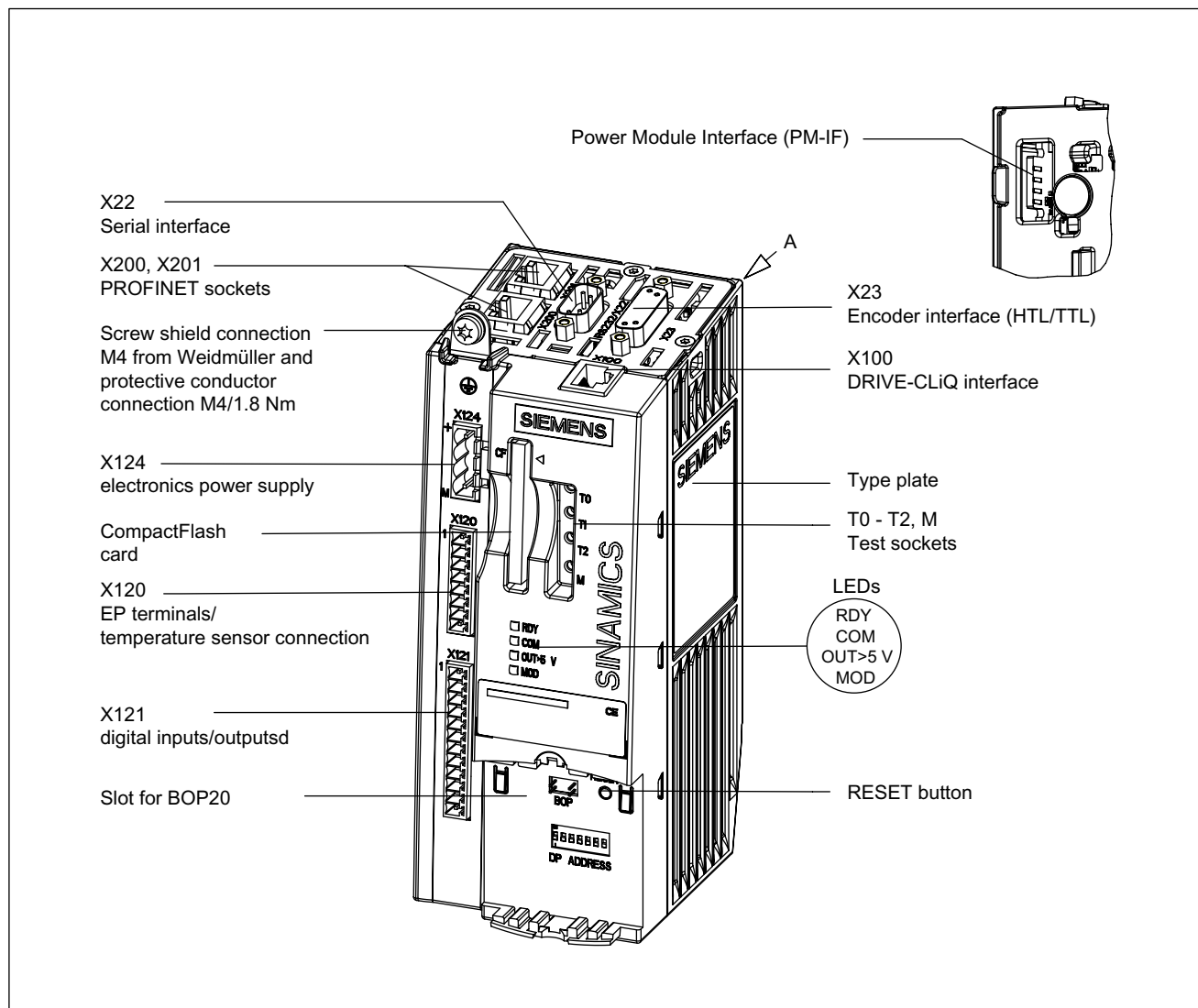

Figure 6-8 Description of the CU310 PN interfaces

#### Note

The PROFIBUS address switch is present for the CU310 PN, however it has not function.

6.3.3.2 Sample connection

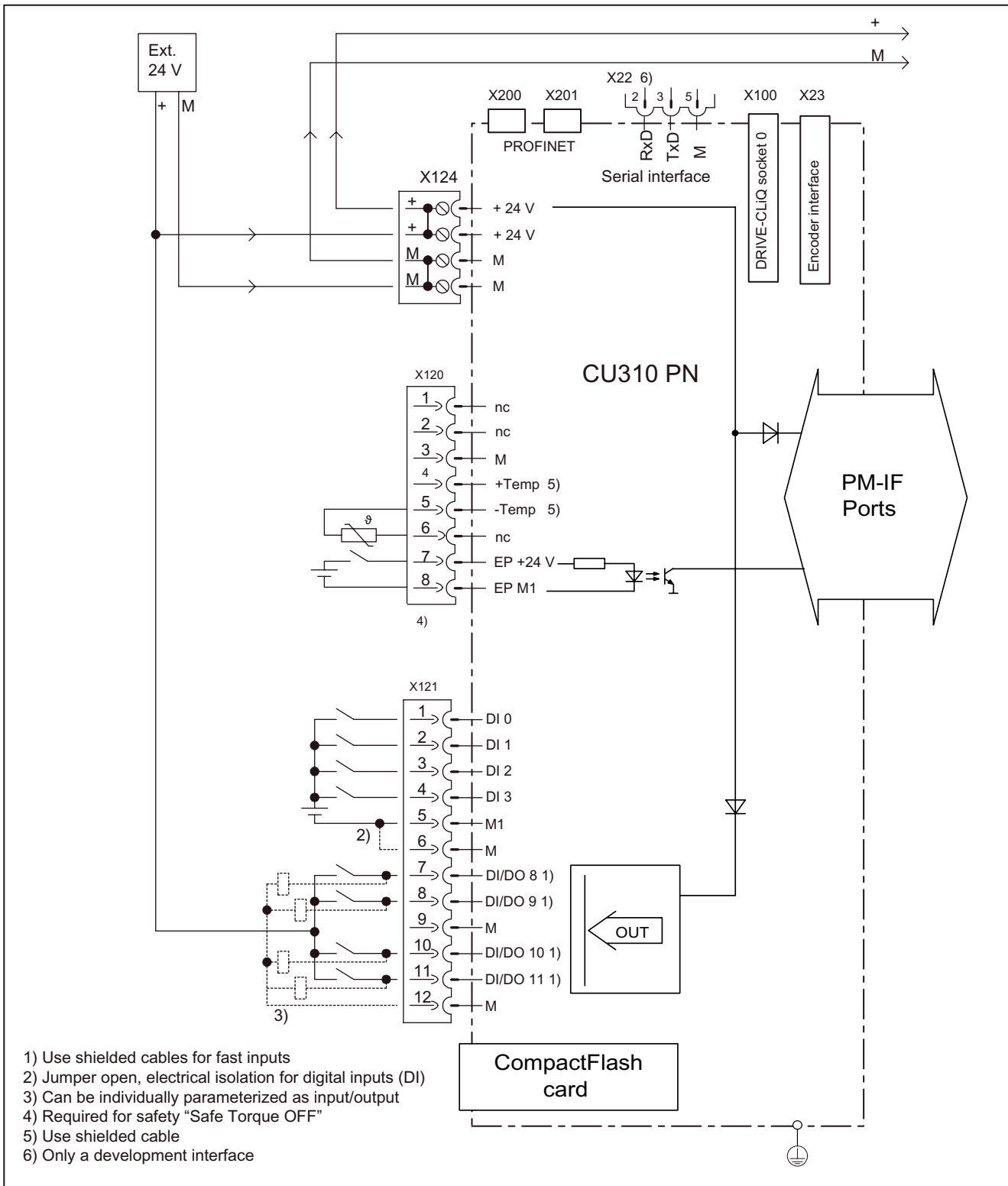
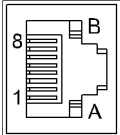

Figure 6-9 Connection example CU310 PN



### 6.3.3.3 X100 DRIVE-CLiQ interface

Table 6-14 DRIVE-CLiQ interface

	Pin	Signal name	Technical specifications
	1	TXP	Transmit data +
	2	TXN	Transmit data -
	3	RXP	Receive data +
	4	Reserved, do not use	
	5	Reserved, do not use	
	6	RXN	Receive data -
	7	Reserved, do not use	
	8	Reserved, do not use	
	A	+ (24 V)	Power supply
	B	GND (0 V)	Electronic ground
Blanking plate for DRIVE-CLiQ interface: Molex, order number: 85999-3255			
The maximum DRIVE-CLiQ cable length is 100 m.			

### 6.3.3.4 X120 EP terminals / temperature sensor connection

Table 6-15 Terminal strip X120

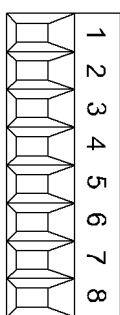
	Terminal	Function	Technical specifications
	1	Reserved, do not use	
	2	Reserved, do not use	
	3	M	Ground
	4	+Temp	KTY or PTC input
	5	-Temp	Ground for KTY or PTC
	6	Reserved, do not use	
	7	EP +24 V	Safe standstill input (+)
	8	EP M1	Safe standstill input (-)
Max. cross-section that can be connected 1.5 mm <sup>2</sup>			

#### Notice

The KTY temperature sensor/the PTC must be connected with the correct polarity.

6.3.3.5 X121 digital inputs/outputs

Table 6-16 Terminal strip X121

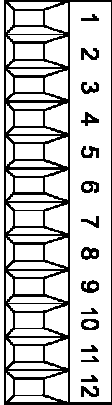
	Terminal	Designation <sup>1)</sup>	Technical specifications
	1	DI 0	Voltage: -3 V to 30 V Typical current consumption: 10 mA at 24 V DC Isolation: The reference potential is terminal M1 Level (incl. ripple) High level: 15 V to 30 V Low level: -3 V to 5 V
	2	DI 1	
	3	DI 2	
	4	DI 3	
	5	M1	Signal propagation times: L → H approx. 50 µs H → L: approx. 100 µs
	6	M	
	7	DI/DO 8	As input: Voltage: -3 V to 30 V Typical current consumption: 10 mA at 24 V DC Level (incl. ripple) High level: 15 V to 30 V Low level: -3 V to 5 V Terminal numbers 8, 10, and 11 are "fast inputs" Signal propagation times for inputs/"fast inputs": L → H: approx. 50 µs/5 µs H → L: approx. 100 µs/50 µs As output: Voltage: 24 V DC Max. load current per output: 500 mA Continued-short-circuit-proof
	8	DI/DO 9	
	9	M	
	10	DI/DO 10	
	11	DI/DO 11	
	12	M	
Max. cross-section that can be connected: 1.5 mm <sup>2</sup> Type: Spring-loaded terminal 1 (see Appendix A)			

1) DI: digital input; DI/DO: Bidirectional digital input/output; M: Electronic ground M1: Ground reference

**Notice**

An open input is interpreted as "low".

The "fast inputs" can be used in conjunction with a measuring system for position sensing.

To enable digital inputs (DI) 0 to 3 to function, terminal M1 must be connected. This can be done as follows:

Connect the digital inputs' ground reference, or a jumper to terminal M. This removes the electrical isolation for these digital inputs.

**Note**

An external 24 V power supply is required.

If a the 24 V power supply voltage is briefly interrupted, then the digital outputs are deactivated during this time.

### 6.3.3.6 Electronics power supply X124

Table 6-17 Terminal block X124

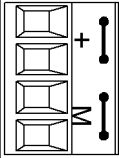
	Terminal	Function	Technical specifications
	+	Electronics power supply	Voltage: 24 V DC (20.4 V - 28.8 V) Current consumption: max. 0.8 A (without DRIVE-CLiQ or digital outputs) Max. current via jumper in connector: 20 A at 55 °C
	+	Electronics power supply	
	M	Electronic ground	
	M	Electronic ground	
Max. cross-section that can be connected: 2.5 mm <sup>2</sup> Type: Screw terminal 2 (see Appendix A)			

#### Note

The two “+” and “M” terminals are jumpered in the connector. This ensures the supply voltage is looped through.

The current consumption increases by the value for the DRIVE-CLiQ node.

### 6.3.3.7 X200 - X201 PROFINET

Table 6-18 PROFINET interfaces X200 - X201

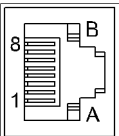
	Pin	Signal name	Meaning
	1	TXP	Transmit data +
	2	TXN	Transmit data -
	3	RXP	Receive data +
	4	Reserved, do not use	
	5	Reserved, do not use	
	6	RXN	Receive data -
	7	Reserved, do not use	
	8	Reserved, do not use	
Connector type: RJ45plus socket Cable type: PROFINET			

6.3.3.8 X23 HTL/ TTL encoder interface

Table 6-19 Encoder connection X23

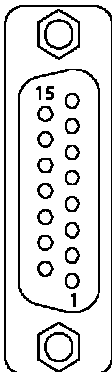
	Pin	Signal name	Technical specifications
	1	Reserved, do not use	
	2	SSI_CLK	SSI clock, positive
	3	SSI_XCLK	SSI clock, negative
	4	PENC	Encoder power supply
	5	PENC	Encoder power supply
	6	PSENSE	Remote sense encoder power supply (P)
	7	M	Electronic ground
	8	Reserved, do not use	
	9	MSENSE	Remote sense encoder power supply (N)
	10	RP	R track positive
	11	RN	R track negative
	12	BN	B track negative
	13	BP	B track positive
	14	AN_SSI_XDAT	A track negative / SSI data negative
	15	AP_SSI_DAT	A track positive / SSI data positive

Type: 15-pin SUB D connector

6.3.3.9 X22 serial interface (RS232)

Table 6-20 Serial interface (RS-232-C) X140

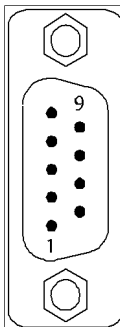
	Pin	Designation	Technical data
	2	RxD	Receive data
	3	TxD	Transmit data
	5	Ground	Ground reference

Type: 9-pin SUB D connector

### 6.3.3.10 Measurement sockets T0, T1, and T2

Table 6-21 Measurement sockets T0, T1, and T2

Socket	Function	Technical specifications
T0	Measurement socket 0	Voltage: 0 V to 5 V Resolution: 8 bits Load current: max. 3 mA Continued-short-circuit-proof The reference potential is terminal M
T1	Measurement socket 1	
T2	Measurement socket 2	
M	Ground	

The measurement sockets are only suitable for bunch pin plugs with a diameter of 2 mm.

## 6.3.3.11 Description of the LEDs on the Control Unit 310 PN

Table 6-22 Description of the LEDs on the Control Unit

LED	Color	State	Description
RDY (READY)	-	Off	Electronics power supply outside permissible tolerance range
	Green	Steady light	The component is ready for operation and cyclic DRIVE-CLiQ communication is taking place.
		Flashing light 2 Hz	Writing to CompactFlash card.
	Red	Steady light	At least one fault is present in this component.
		Flashing light 0.5 Hz	CompactFlash card has not been inserted. Boot error (e.g. firmware cannot be loaded to the RAM).
	Green Red	Flashing light 0.5 Hz	Control Unit 310 PN is ready for operation. No software licenses for device.
	Orange	Steady light	DRIVE-CLiQ communication is being established.
		Flashing light 0.5 Hz	Unable to load firmware to RAM
Flashing light 2 Hz		Firmware CRC error	
COM (PROFIBUS cyclic operation)	-	Off	Cyclic communication is not (yet) running. Note: The PROFINET is ready for communication when the Control Unit is ready for operation (see RDY LED).
	Green	Steady light	Cyclic communication is running.
		Flashing light 0.5 Hz	Cyclic communication is not yet running fully. Possible reasons: <ul style="list-style-type: none"> <li>The master is not transmitting setpoints.</li> <li>No global control (GC) or master sign-of-life is transmitted during isochronous operation.</li> </ul>
Red	Steady light	Cyclic communication has been interrupted.	
OUT>5V	-	Off	Electronics power supply is missing or outside permissible tolerance range. Power supply $\leq 5$ V.
	Orange	Steady light	Electronics power supply for measuring system available. Power supply $> 5$ V. <b>Notice</b> You must ensure that the connected encoder can be operated with a 24 V supply. If an encoder that is designed for a 5 V supply is operated with a 24 V supply, this can destroy the encoder electronics.
MOD	--	Off	Reserved

### Cause and rectification of faults

The following reference contains information about the cause and rectification of faults:

Reference: //IH1/ SINAMICS S120 Commissioning Manual.

### RESET button

The RESET button is located behind the blanking plate.

### 6.3.4 Dimension drawing

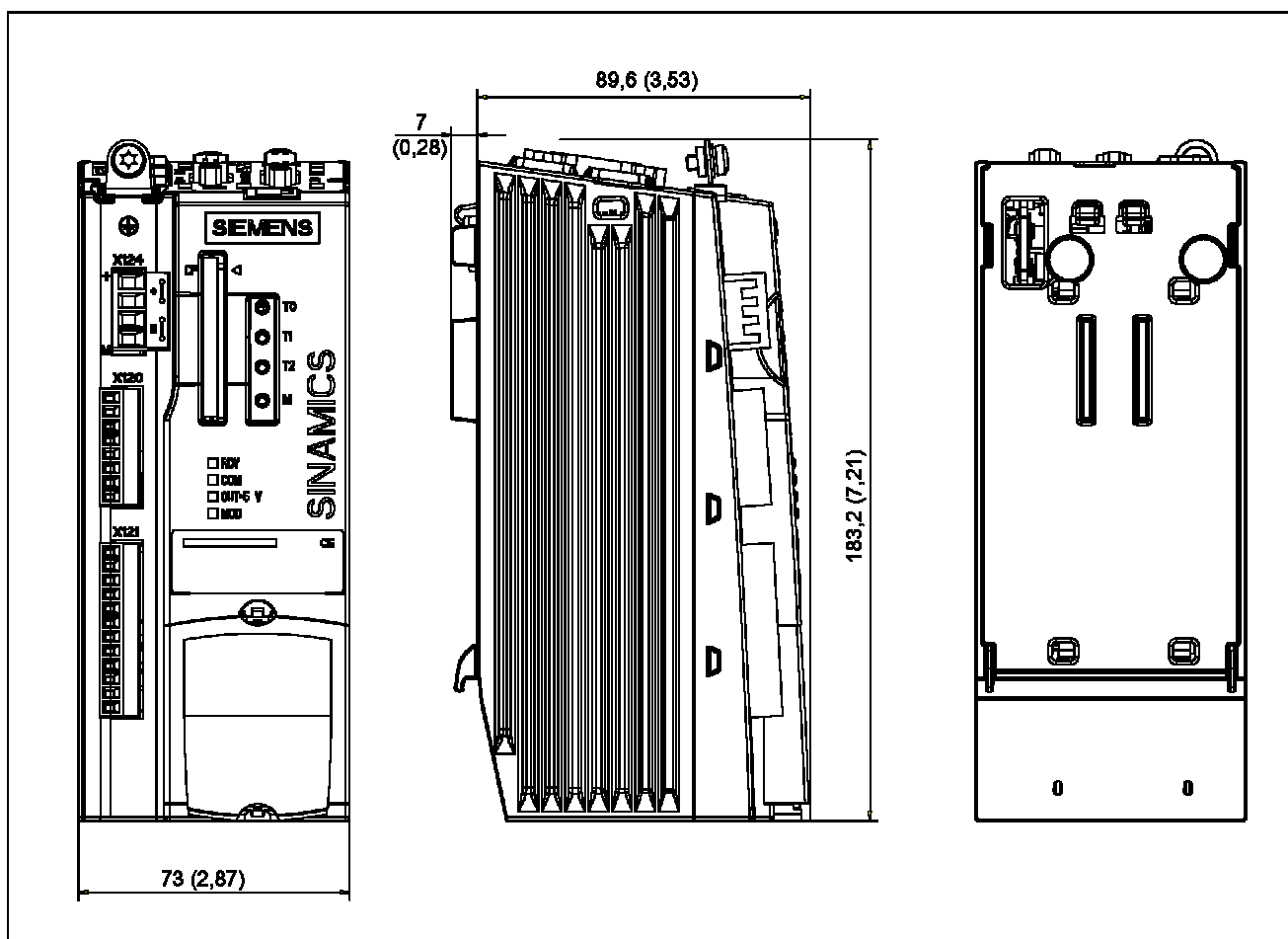
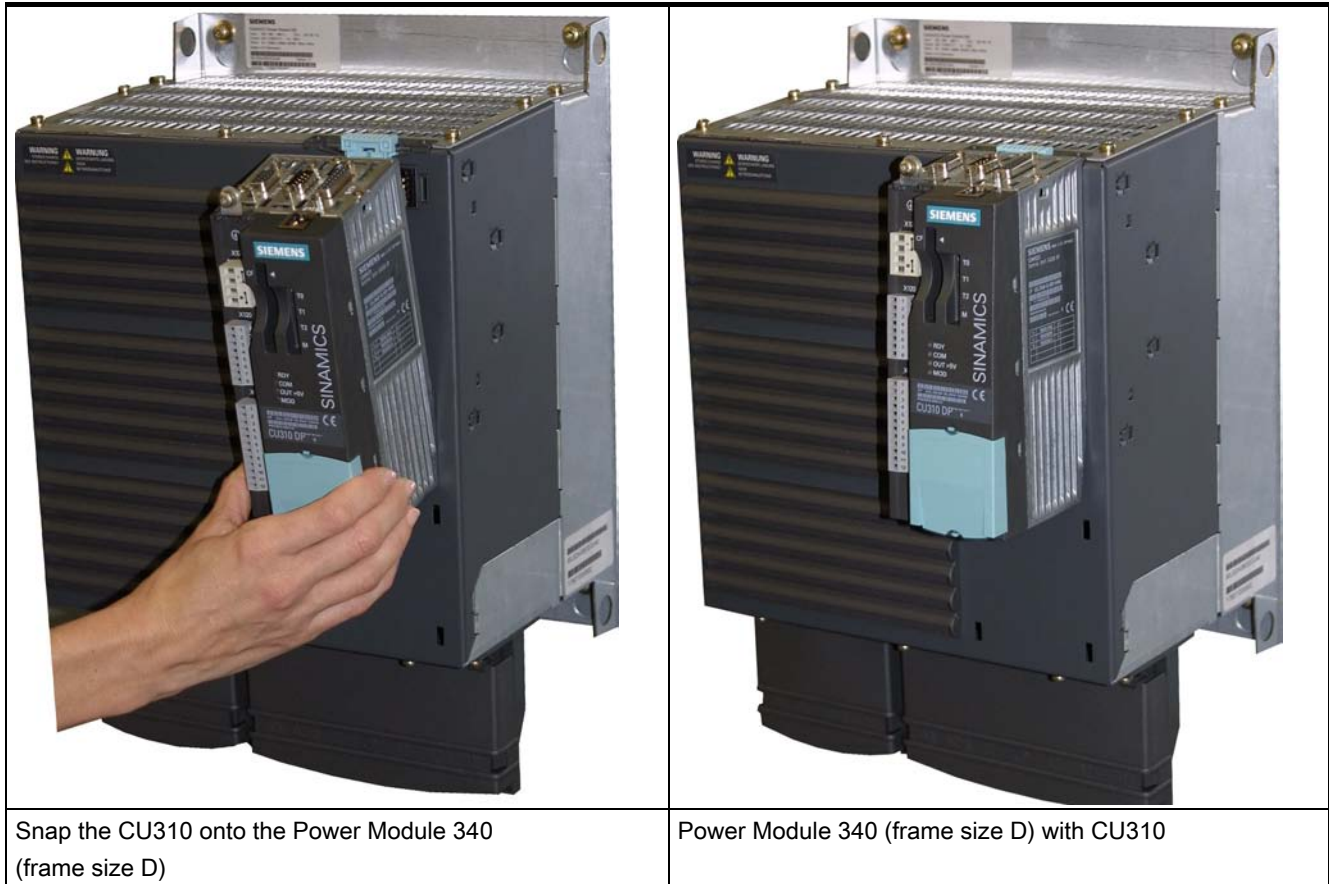

Figure 6-10 Dimension drawing, CU310 PN

### 6.3.5 Mounting the CU310 on the Power Module Blocksize

As soon as the Power Module has been correctly installed, the Control Unit can be attached to the Power Module.



The procedure when mounting the Control Unit on the Power Module is independent of the frame size of the Power Modules.



## Removing the Control Unit



In order to remove the Control Unit from the Power Module, the blue release lever, as shown in the diagram, must be pressed downwards and the Control Unit swung-out to the front.

## 6.3.6 Technical data

Table 6-23 Technical data CU310 PN

	Unit	Value
Electronics power supply		
Voltage	V <sub>DC</sub>	DC 24 (20.4 – 28.8)
Current (without DRIVE-CLiQ and digital outputs)	A <sub>DC</sub>	0.8
Power loss	W	20
PE/ground connection	At the housing with M4/3 Nm screw	
Response time	The response time of digital inputs/outputs depends on the evaluation (refer to the function diagram). <b>Reference:</b> /LH1/ SINAMICS S List Manual, Chapter "Function diagrams".	
Weight	kg	0.99

## 6.4 Control Unit Adapter 31 (CUA31)

### 6.4.1 Description

The Control Unit Adapter 31 (CUA31), combined with a modular power unit is used to extend an existing DC/AC drive line-up e.g. with CU320 by one drive.

The closed-loop control is externally implemented. This is the reason that a SINAMICS, SIMOTION or SINUMERIK closed-loop control is always required for operation.

The maximum DRIVE-CLiQ cable length is 50 m.

The Control Unit Adapter 31 has the following interfaces (ports):

Table 6-24 Interface overview of the CUA31

Type	Number
DRIVE-CLiQ interfaces	3
EP terminal / temperature sensor connection	1
Power Module Interface (PM-IF)	1
24 V electronics power supply	1

### 6.4.2 Safety Information



---

#### Caution

The cooling clearances of 50 mm above and below the components must be observed. It is not permissible that the connecting cables cover the cooling openings.

---

### 6.4.3 Interface description

#### 6.4.3.1 Overview

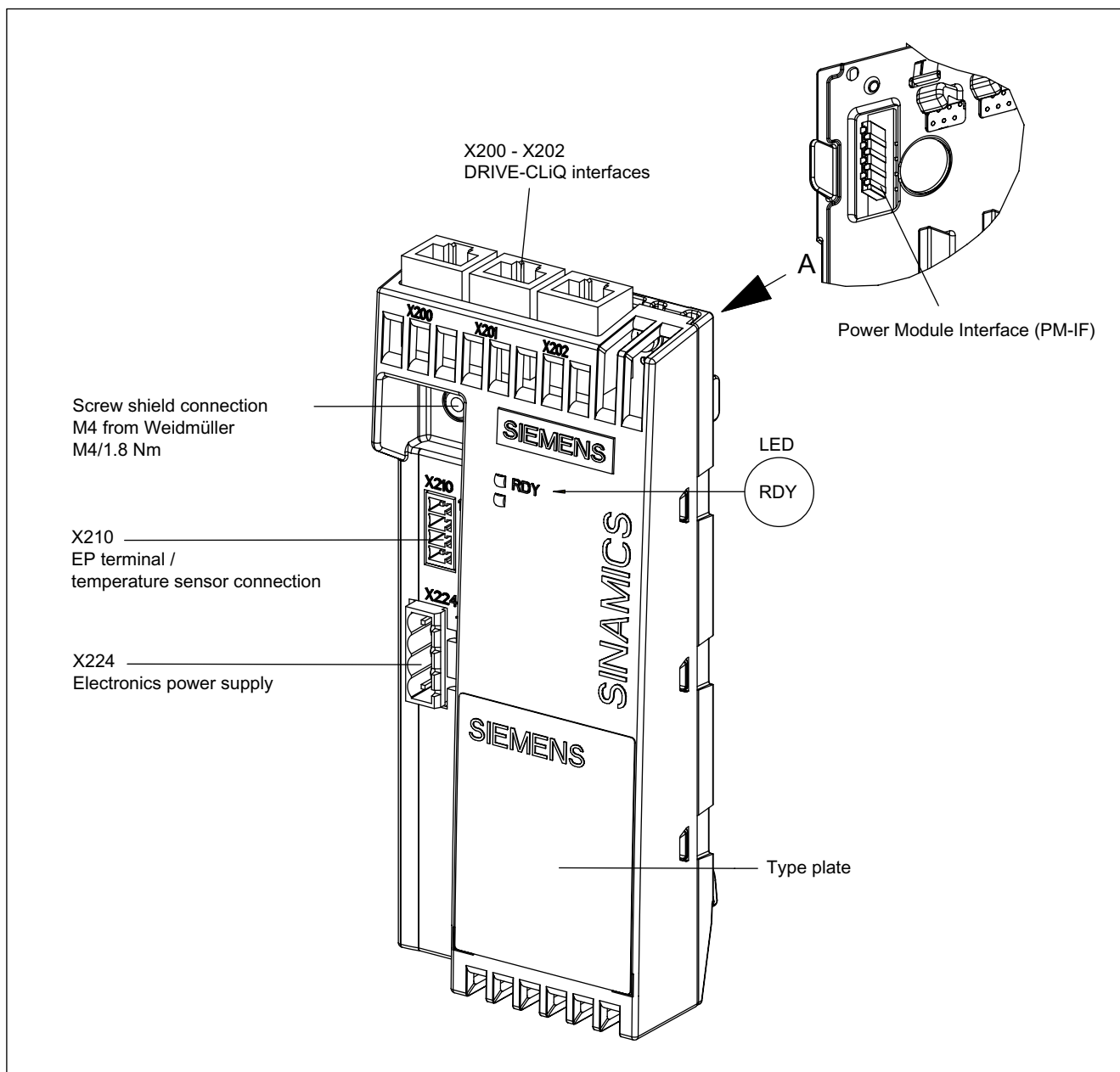

Figure 6-11 Interface description CUA31

6.4 Control Unit Adapter 31 (CUA31)

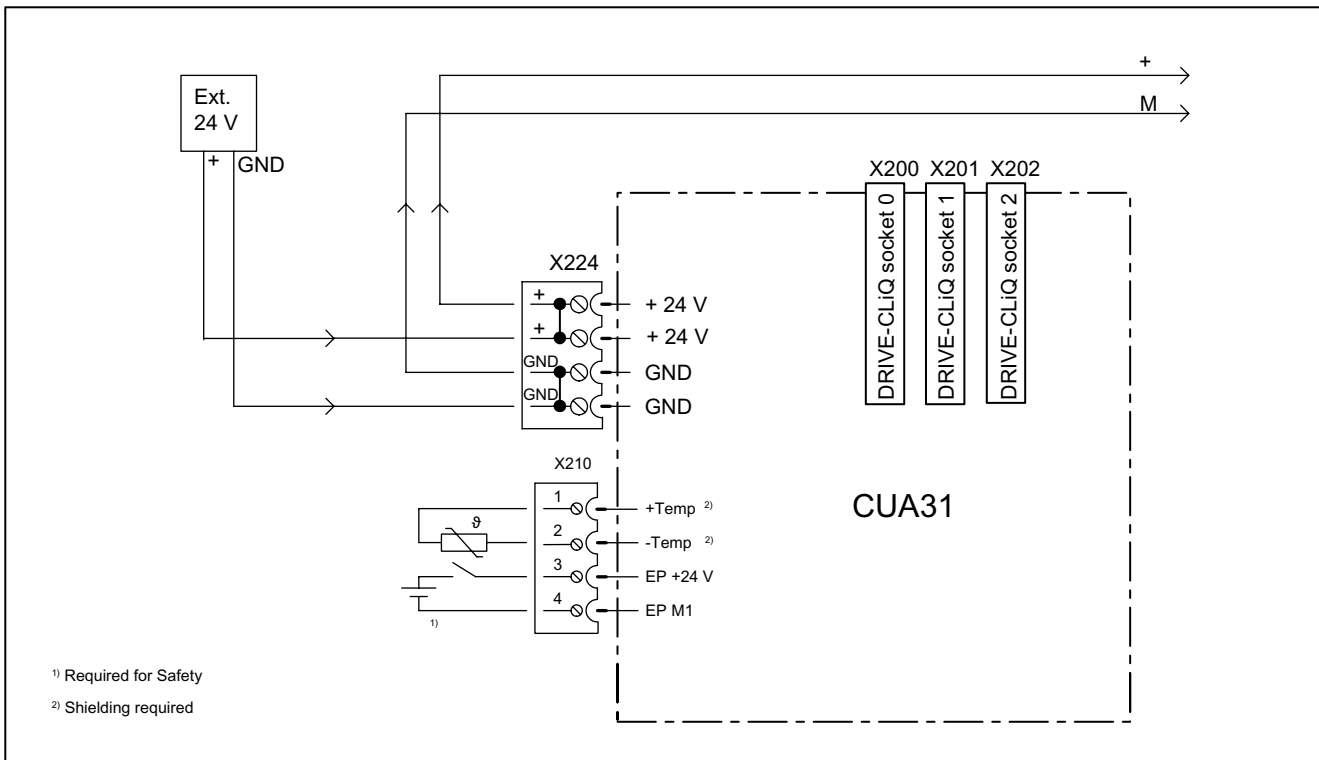

Figure 6-12 Connection example, CUA31

6.4.3.2 X200 - X202 DRIVE-CLiQ interface

Table 6-25 DRIVE-CLiQ interface

	Pin	Signal name	Technical specifications
	1	TXP	Transmit data +
	2	TXN	Transmit data -
	3	RXP	Receive data +
	4	Reserved, do not use	
	5	Reserved, do not use	
	6	RXN	Receive data -
	7	Reserved, do not use	
	8	Reserved, do not use	
	A	+ (24 V)	Power supply
	B	GND (0 V)	Electronic ground

Blanking plate for DRIVE-CLiQ interface: Molex, order number: 85999-3255

The maximum DRIVE-CLiQ cable length is 50 m.

### 6.4.3.3 X224 electronics power supply

Table 6-26 Terminal strip X224

	Terminal	Function	Technical specifications
	+	Electronics power supply	Voltage: 24 V DC (20.4 V - 28.8 V) Current consumption: max. 0.8 A (without DRIVE-CLiQ or digital outputs) Max. current via jumper in connector: 20 A at 55 °C
	+	Electronics power supply	
	M	Electronic ground	
	M	Electronic ground	
Max. cross-section that can be connected: 2.5 mm <sup>2</sup> Type: Screw terminal 2 (see Appendix A)			

#### Note

The two "+" and "M" terminals are jumpered in the connector. This ensures the supply voltage is looped through.

The current consumption increases by the value for the DRIVE-CLiQ node.

### 6.4.3.4 X210 EP terminals / temperature sensor connection

Table 6-27 Terminal strip X210

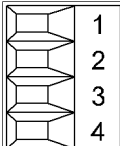
	Terminal	Function	Technical specifications
	1	+Temp	Temperature sensor connection KTY84-1C130/PTC
	2	-Temp	
	3	EP +24 V (Enable Pulses)	Supply voltage: 24 V DC (20.4 V - 28.8 V) Current consumption: 10 mA Isolated input Signal propagation times: L → H 100 μs H → L: 1000 μs
	4	EP M1 (Enable Pulses)	
Max. cross-section that can be connected 1.5 mm <sup>2</sup> Type: Screw terminal 1 (see Connection Methods)			

#### Notice

The KTY temperature sensor/the PTC must be connected with the correct polarity.

#### Note

The temperature sensor connection is required for motors whose temperature value is not transmitted by DRIVE-CLiQ.

If the "safe standstill" function is selected, 24 V DC must be applied to terminal 3 and M must be applied to terminal 4. Upon removal, pulse inhibit is activated.

6.4.3.5 Description of the LEDs at the Control Unit Adapter 31

Table 6-28 Description of the LEDs at the Control Unit Adapter 31

LED	Color	State	Description
RDY (READY)	Red	Steady light	At least one fault is present in this component.
	Green	Steady light	The component is ready for operation and cyclic DRIVE-CLiQ communication is taking place.

Cause and rectification of faults

The following reference contains information about the cause and rectification of faults:

Reference: /IH1/ SINAMICS S120 Commissioning Manual.

6.4.4 Dimension drawing

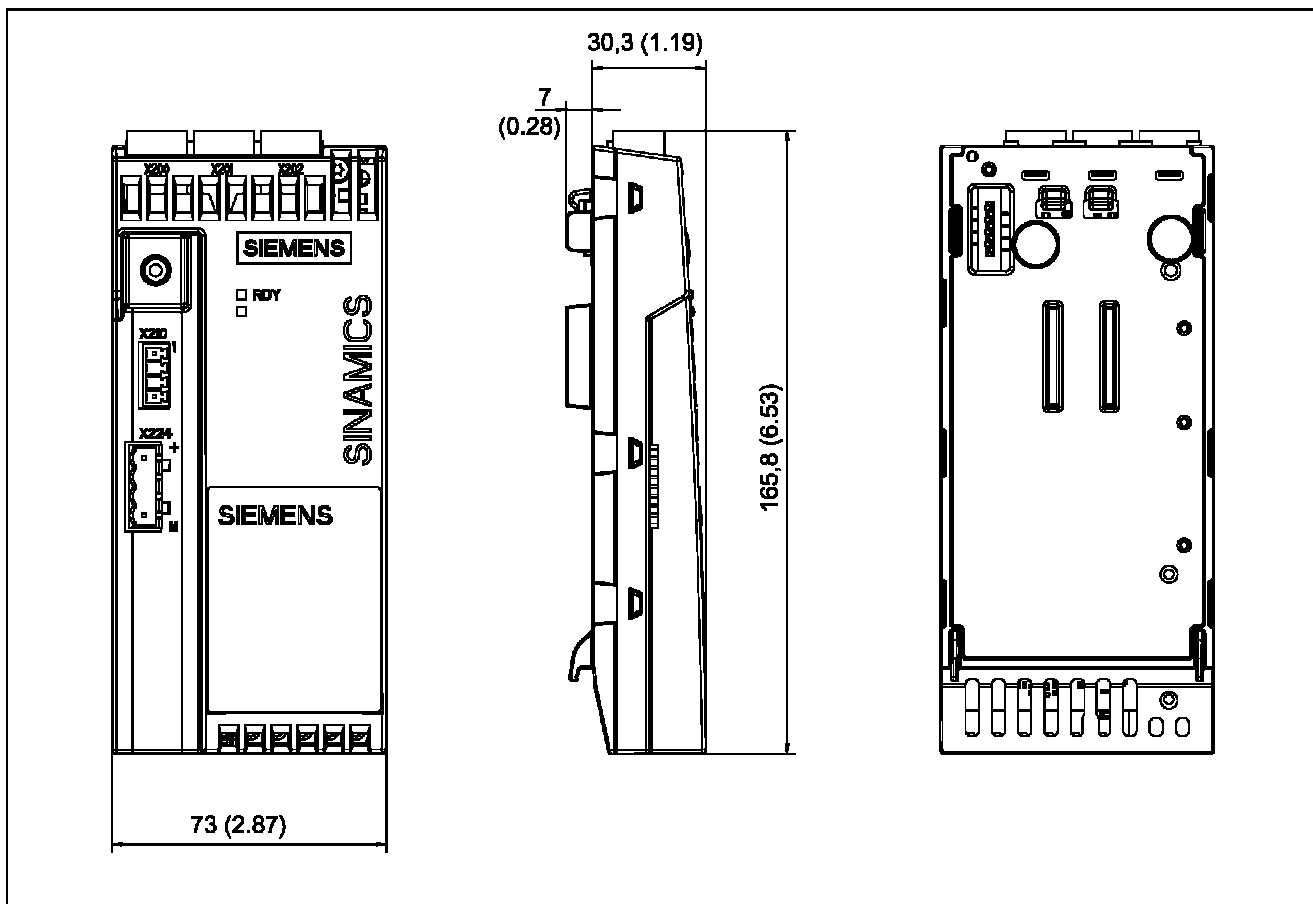
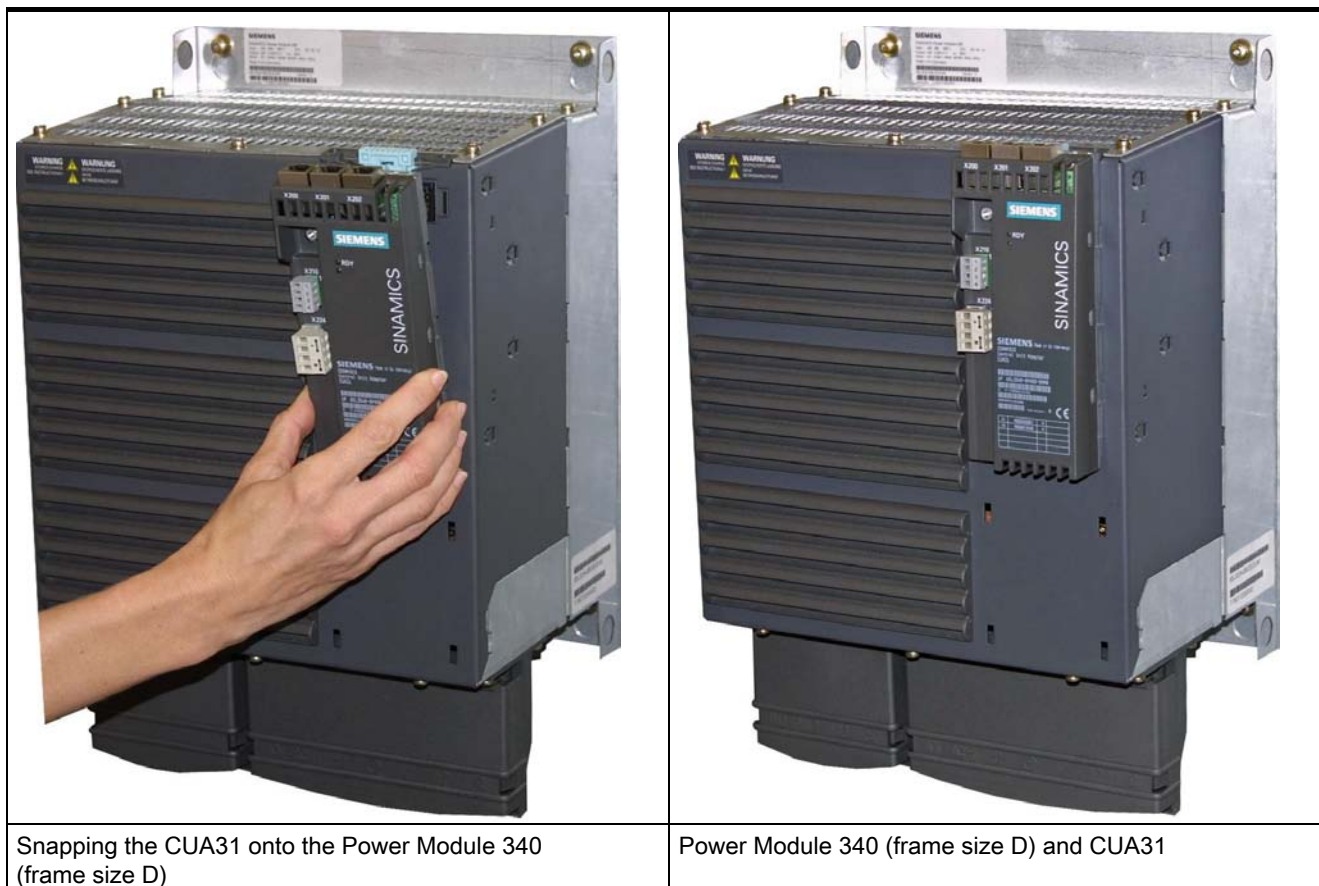

Figure 6-13 Dimension drawing, Control Unit Adapter 31

### 6.4.5 Mounting



### Removing the Control Unit Adapters 31



Removing the CUA31 from the Power Module 340 (frame size D)

In order to remove the Control Unit Adapter 31 from the Power Module, the blue release lever, as shown in the diagram, must be pressed downwards and the Control Unit Adapter 31 is swung-out to the front.

### 6.4.6 Technical data

Table 6-29 Technical data CUA31

	Unit	Value
Electronics power supply		
Voltage	V <sub>DC</sub>	DC 24 (20.4 – 28.8)
Current (without DRIVE-CLiQ and digital outputs)	A <sub>DC</sub>	0.8
Power loss	W	7.2
Weight	kg	0.31



# Supplementary system components and encoder system integration

# 7

## 7.1 Basic Operator Panel 20 (BOP20)

### 7.1.1 Description

The Basic Operator Panel 20 (BOP20) is a basic operator panel with six keys and a display unit with background lighting. The BOP20 can be inserted on the SINAMICS Control Unit CU310 DP / PN and operated.

The following functions are possible with the BOP:

- Input of parameters and activation of functions
- Display of operating modes, parameters, alarms and faults

### 7.1.2 Interface description



Figure 7-1 Basic Operator Panel (BOP20)

Overview of displays and keys

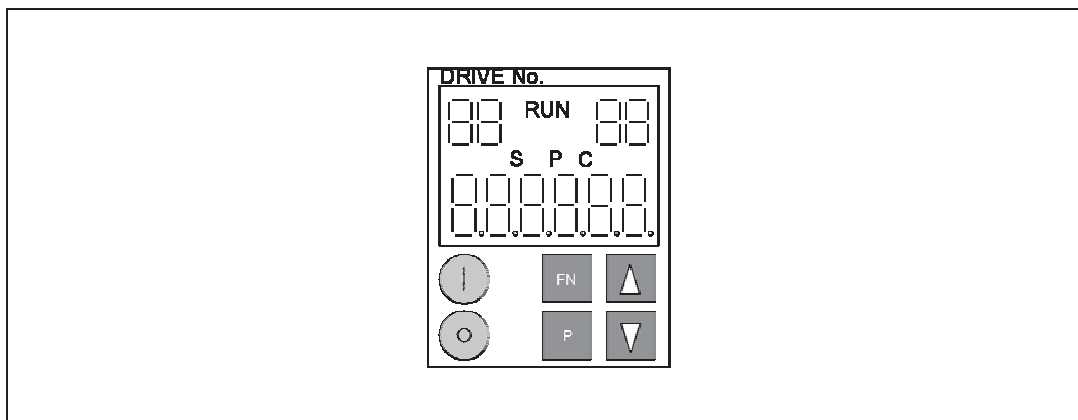







Figure 7-2 Overview of displays and keys

Table 7-1 Displays

Display	Meaning
top left 2 positions	The active drive object of the BOP is displayed here. The displays and key operations always refer to this drive object.
RUN	Is lit (bright) if the displayed drive is in the RUN state (in operation).
top right 2 positions	The following is displayed in this field: <ul style="list-style-type: none"> <li>• More than 6 digits: Characters that are present but cannot be seen (e.g. "r2" → 2 characters to the right are invisible, "L1" → 1 character to the left is invisible)</li> <li>• Faults: Selects/displays other drives with faults</li> <li>• Designation of BICO inputs (bi, ci)</li> <li>• Designation of BICO outputs (bo, co)</li> </ul> Source object of a BICO interconnection to a drive object different than the active one.
S	Is (bright) if at least one parameter was changed and the value was not transferred into the non-volatile memory.
P	Is lit (bright) if, for a parameter, the value only becomes effective after pressing the P key.
C	Is light (bright) if at least one parameter was changed and the calculation for consistent data management has still not been initiated.
Below, 6 position	Displays, e.g. parameters, indices, faults and alarms.

## BOP20 keyboard

Table 7-2 Assignment of the BOP20 keyboard

Key	Name	Meaning
	ON	Powers-up the drive - the "ON/OFF1", "OFF2" or "OFF3" commands for this purpose should come from the BOP.
	OFF	Powers-down the drive - the "ON/OFF1", "OFF2" or "OFF3" commands for this purpose should come from the BOP.
		<p><b>Note:</b></p> <p>The effectiveness of these keys can be defined using the appropriate BICO parameterization (e.g. using these keys, it is possible to simultaneously control all of the axes that have been configured).</p> <p>The structure of the BOP control word corresponds to the structure of the PROFIBUS control word.</p>
	Functions	<p>The significance of these keys depends on the actual display.</p> <p><b>Note:</b></p> <p>The effectiveness of this key to acknowledge faults can be defined using the appropriate BiCo parameterization.</p>
	Parameter	The significance of these keys depends on the actual display.
	Raise	The keys are dependent on the actual display and are used to raise or lower values.
	Lower	





## Displays and operating the BOP20

Information about the displays and using the BOP20 is provided in the following reference:

Reference: /IH1/ SINAMICS S120 Commissioning Manual.

### 7.1.3 Mounting

Table 7-3 Mounting

	
<p>1. CU310 and BOP20</p>	<p>2. Press the bars of the dummy cover together</p>
	
<p>3. Remove the dummy cover</p>	<p>4. Locate the BOP20</p>

**Note**

The Basic Operator Panel 20 (BOP20) may be inserted and withdrawn while the Control Unit is operational.

## 7.1.4 Technical data

Table 7-4 Technical data

<b>Basic Operator Panel 20 (BOP20)</b>		
Weight, approx.	kg	0.02

## 7.2 Terminal Module 31 (TM31)

### 7.2.1 Description

The Terminal Module 31 (TM31) is a terminal expansion module for snapping on to a DIN 50022 mounting rail. Terminal Module TM31 can be used to increase the number of available digital inputs/digital outputs and also the number of analog inputs/analog outputs within a drive system.

The TM31 contains the following terminals:

Table 7-5 Interface overview of the TM31

<b>Type</b>	<b>Number</b>
Digital inputs	8
Digital inputs/outputs	4
Analog inputs	2
Analog outputs	2
Relay outputs	2
Temperature sensor input	1

### 7.2.2 Safety information



---

#### **Caution**

The cooling clearances of 50 mm above and below the components must be observed.

---



---

#### **Caution**

Connecting cables to temperature sensors must always be installed with shielding. The cable shield must be connected to the chassis potential at both ends over a large surface area. Temperature sensor cables that are routed together with the motor cable must be twisted in pairs and shielded separately.

---

### 7.2.3 Interface description

#### 7.2.3.1 Overview

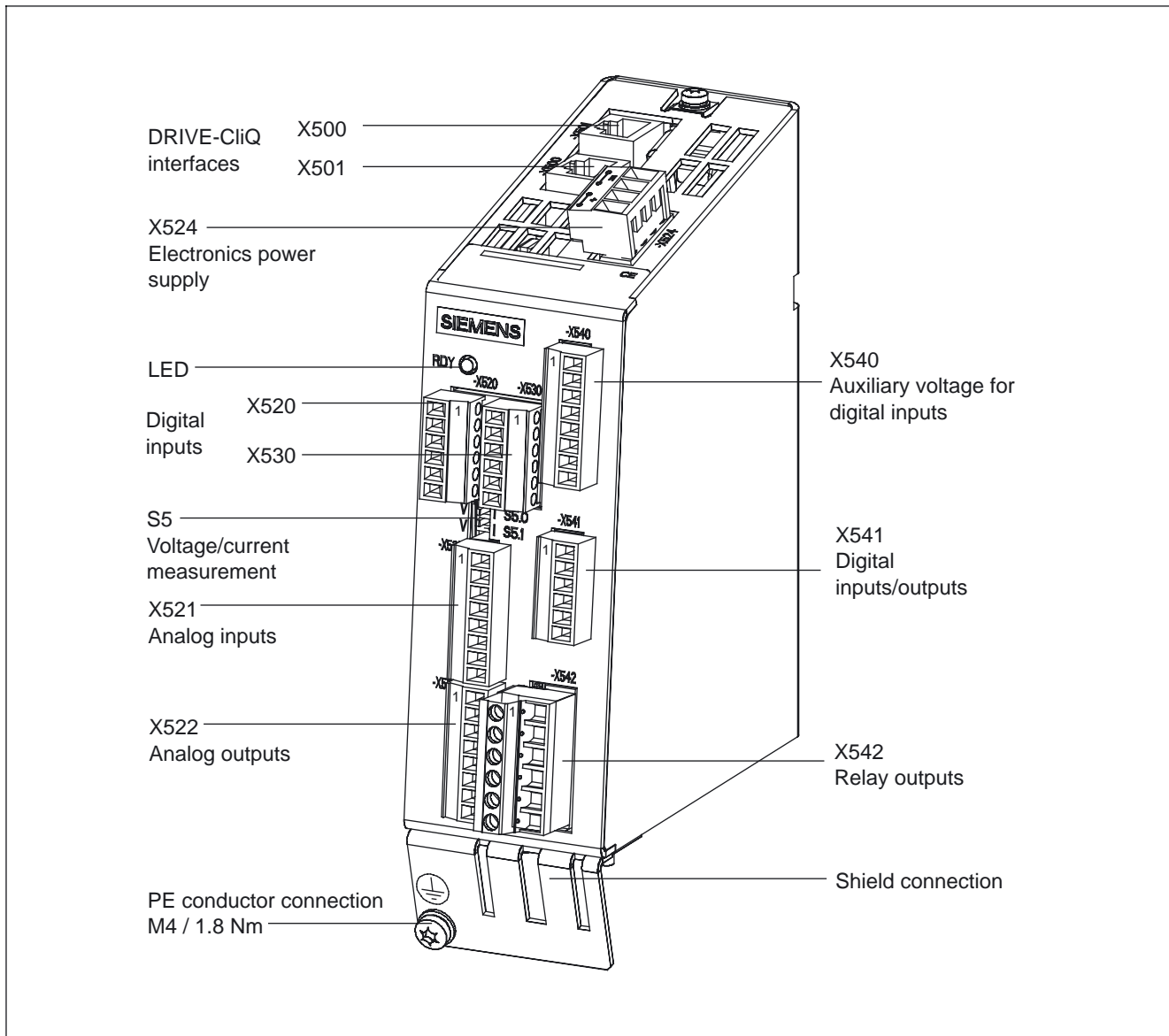

Figure 7-3 Interface description TM31

7.2.3.2 Sample connection

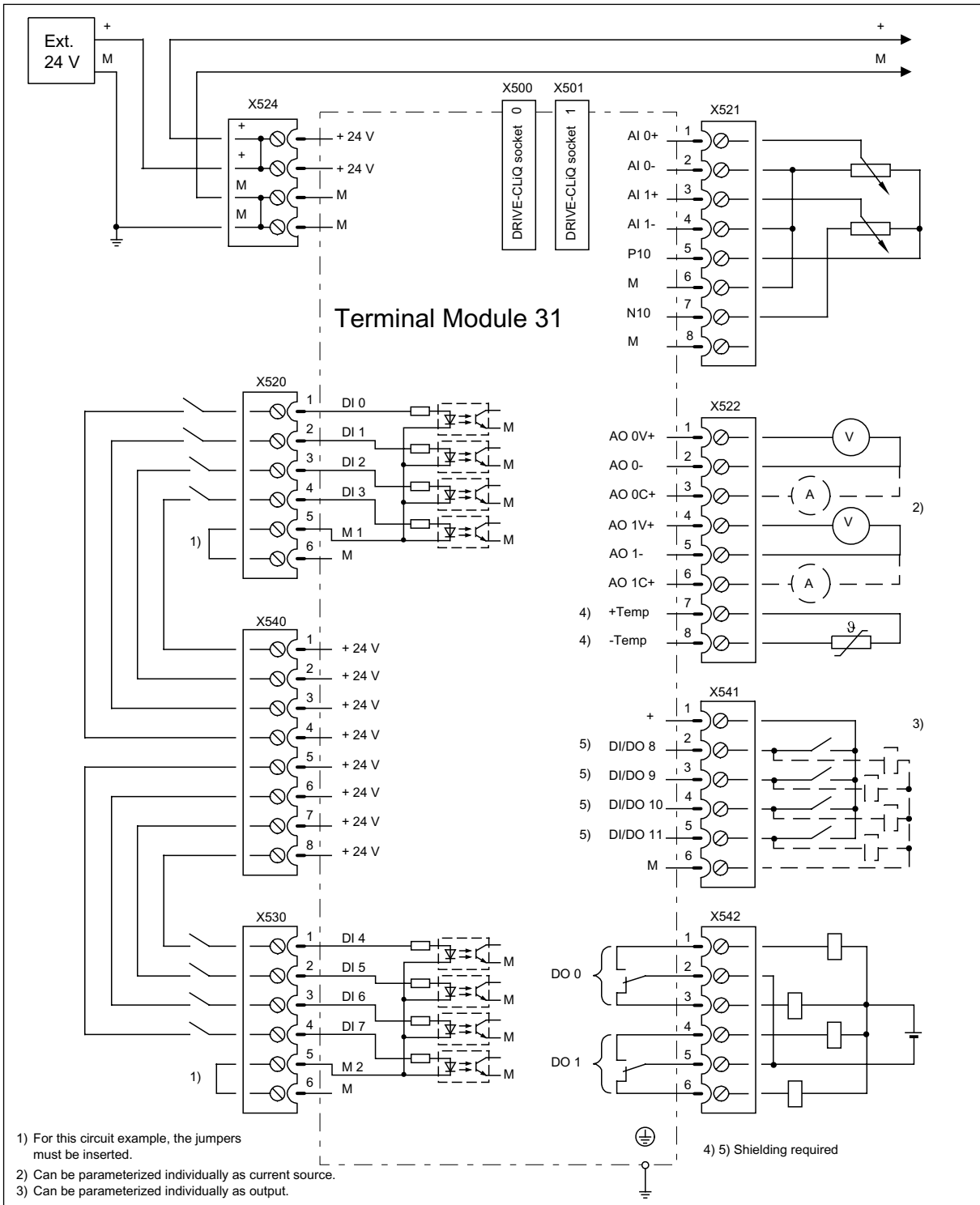
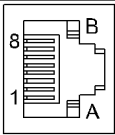

Figure 7-4 Example connection of TM31

### 7.2.3.3 X500 and X501 DRIVE-CLiQ interface

Table 7-6 DRIVE-CLiQ interface X500

	Pin	Signal name	Technical specifications
	1	TXP	Transmit data +
	2	TXN	Transmit data -
	3	RXP	Receive data +
	4	Reserved, do not use	
	5	Reserved, do not use	
	6	RXN	Receive data -
	7	Reserved, do not use	
	8	Reserved, do not use	
	A	+ (24 V)	Power supply
	B	GND (0 V)	Electronic ground

Blanking plate for DRIVE-CLiQ interface: Molex, order number: 85999-3255

### 7.2.3.4 Electronics power supply X524

Table 7-7 Terminals for the electronics power supply

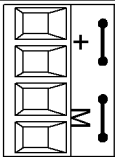
	Terminal	Designation	Technical specifications
	+	Electronics power supply	Voltage: 24 V DC (20.4 V – 28.8 V) Current consumption: max. 0.5 A
	+	Electronics power supply	
	M	Electronic ground	Max. current via jumper in connector: 20 A at 55 °C
	M	Electronic ground	

Max. cross-section that can be connected: 2.5 mm<sup>2</sup>  
Type: Screw terminal 2 (see Appendix A)

**Note**

The two “+” and “M” terminals are jumpered in the connector. This ensures the supply voltage is looped through.

The current consumption increases by the value for the DRIVE-CLiQ node and digital outputs.



### 7.2.3.5 Digital inputs X520

Table 7-8 Screw terminal X520

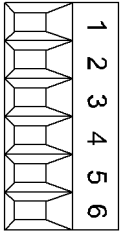
	Terminal	Designation <sup>1)</sup>	Technical specifications
	1	DI 0	Voltage: - 3 V to +30 V Typical current consumption: 10 mA at 24 V DC Isolation: The reference potential is terminal M1 Signal propagation times: L → H approx. 50 μs H → L: approx. 100 μs Level (incl. ripple) High level: 15 V to 30 V Low level: -3 V to 5 V
	2	DI 1	
	3	DI 2	
	4	DI 3	
	5	M1	
	6	M	
Max. cross-section that can be connected: 1.5 mm <sup>2</sup> Type: Screw terminal 1 (see Appendix A)			

1) DI: digital input; M: electronic ground M1: Ground reference

#### Note

To enable the digital inputs to function, terminal M1 must be connected. This can be done as follows:

- 1) Connect the reference ground of the digital inputs, or
  - 2) a jumper to terminal M
- (Notice: this removes isolation for these digital inputs).**

7.2.3.6 Digital inputs X530

Table 7-9 Screw terminal X530

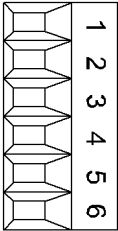
	Terminal	Designation <sup>1)</sup>	Technical specifications
	1	DI 4	Voltage: -3 V to 30 V Typical current consumption: 10 mA at 24 V DC Isolation: The reference potential is terminal M2 Signal propagation times: L → H approx. 50 μs H → L: approx. 100 μs Level (incl. ripple) High level: 15 V to 30 V Low level: -3 V to 5 V
	2	DI 5	
	3	DI 6	
	4	DI 7	
	5	M2	
	6	M	
Max. cross-section that can be connected: 1.5 mm <sup>2</sup> Type: Screw terminal 1 (see Appendix A)			

1) DI: digital input; M: electronic ground; M2: Ground reference

**Notice**

An open input is interpreted as "low".

To enable the digital inputs to work, terminal M2 must be connected. This can be done as follows:

1) Route the reference ground of the digital inputs (with the other cable) and connect it to M2.

2) Jumper terminal M and M2 directly

(the electrical isolation for these digital inputs is therefore removed).

### 7.2.3.7 Auxiliary voltage for the digital inputs X540

Table 7-10 Screw terminal X540

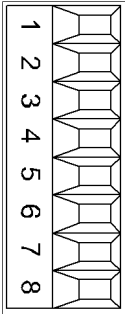
	Terminal	Designation	Technical specifications
	1	+24 V	Voltage: +24 V DC Max. total load current: 150 mA
	2	+24 V	
	3	+24 V	
	4	+24 V	
	5	+24 V	
	6	+24 V	
	7	+24 V	
	8	+24 V	
Max. cross-section that can be connected: 1.5 mm <sup>2</sup> Type: Screw terminal 1 (see Appendix A)			

**Note**

This voltage supply is only for powering the digital inputs.

### 7.2.3.8 Analog inputs X521

Table 7-11 Terminal block X521

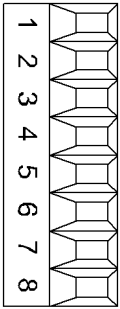
	Terminal	Name <sup>1)</sup>	Technical specifications
	1	AI 0+	You can set the following input signals using the appropriate parameters: Voltage: -10 V to 10 V; R <sub>i</sub> = 100 kΩ Current 1: 4 mA to 20 mA; R <sub>i</sub> = 250 Ω Current 2: -20 mA to 20 mA; R <sub>i</sub> = 250 Ω Current 3: 0 mA to 20 mA; R <sub>i</sub> = 250 Ω Resolution: 12 bits
	2	AI 0-	
	3	AI 1+	
	4	AI 1-	
	5	P10	Auxiliary voltage: P10 = 10 V N10 = -10 V Continued-short-circuit-proof
	6	M	
	7	N10	
	8	M	
Max. connectable cross-section: 1.5 mm <sup>2</sup> Type: Screw terminal 1 (refer to Appendix A)			

1) AI: analog inputs; P10/N10: auxiliary voltage; M or GND: ground reference

#### Caution

If more than 40 mA flows through the analog current input, then the component could be destroyed.

The common mode range may not be violated. This means that the analog differential voltage signals can have a maximum offset voltage of +/-30 V DC with respect to the ground potential. If the range is infringed, incorrect results may occur during analog/digital conversion.

### 7.2.3.9 S5 current/voltage changeover switch for analog inputs

Table 7-12 Current/voltage selector S5

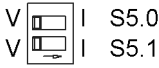
	Switch	Function
	S5.0	Selector voltage (V)/current (I) AI0
	S5.1	Selector voltage (V)/current (I) AI1

### 7.2.3.10 Analog outputs/temperature sensor connection X522

Table 7-13 Terminal block X522

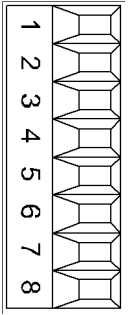
	Terminal	Designation <sup>1)</sup>	Technical specifications
	1	AO 0V+	You can set the following output signals using parameters: Voltage: -10 V to 10 V (max. 3 mA)
	2	AO 0-	
	3	AO 0C+	
	4	AO 1V+	Current 1: 4 mA to 20 mA (max. load resistance $\leq 500 \Omega$ )
	5	AO 1-	Current 2: -20 mA to 20 mA (max. load resistance $\leq 500 \Omega$ )
	6	AO 1C+	Current 3: 0 mA to 20 mA (max. load resistance $\leq 500 \Omega$ )
	7	+Temp	Resolution: 11 bits + sign
	8	-Temp	Continued-short-circuit-proof
			Temperature sensor connection KTY84-1C130/PTC
Max. cross-section that can be connected: 1.5 mm <sup>2</sup>			
Type: Screw terminal 1 (see Appendix A)			

1) AO xV: analog output voltage; AO xC: Analog output current

7.2.3.11 X541 bidirectional digital inputs/outputs

Table 7-14 Terminals for bidirectional digital inputs/outputs

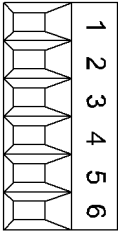
	Terminal	Designation <sup>1)</sup>	Technical specifications
	1	+	As input: Voltage: -3 V to 30 V Typical current consumption: 10 mA at 24 V DC Signal propagation times: L → H approx. 50 μs H → L: approx. 100 μs As output: Voltage: 24 V DC Max. load current per output: 100 mA Max. total current of outputs: 400 mA Continued-short-circuit-proof
	2	DI/DO 8	
	3	DI/DO 9	
	4	DI/DO 10	
	5	DI/DO 11	
	6	M	
Max. cross-section that can be connected: 1.5 mm <sup>2</sup> Type: Screw terminal 1 (see Appendix A)			

1) DI/DO: bidirectional digital input/output; M or GND: Electronic ground

**Note**

An open input is interpreted as "low".

**Note**

If a momentary interruption in the voltage occurs in the 24 V supply, the digital outputs will be deactivated until the interruption has been rectified.

**Notice**

The digital outputs are only functional if terminals 1 and 6 are supplied with 24 V.

### 7.2.3.12 Relay outputs X542

Table 7-15 Terminal block X542

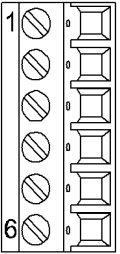
	Terminal	Designation <sup>1)</sup>	Technical specifications
	1	DO 0.NC	Contact type: Two-way contact max. load current: 8 A Max. switching voltage: 250 V <sub>AC</sub> , 30 V <sub>DC</sub> Max. switching power at 250 V <sub>AC</sub> : 2000 VA (cosφ = 1) Max. switching power at 250 V <sub>AC</sub> : 750 VA (cosφ = 0.4) Max. switching power at 30 V <sub>DC</sub> : 240 W (ohmic load) Required minimum current: 100 mA Overvoltage category: Class III to EN 60 664-1
	2	DO 0.COM	
	3	DO 0.NO	
	4	DO 1.NC	
	5	DO 1.COM	
	6	DO 1.NO	
Max. cross-section that can be connected 2.5 mm <sup>2</sup> Type: Screw terminal 3 (see Appendix A)			

1) DO: digital output, NO: normally-open contact, NC: normally-closed contact, COM: Mid-position contact

### 7.2.3.13 Description of the LEDs on the Terminal Module 31 (TM31)

Table 7-16 Description of the LEDs on the TM31

LED	Color	State	Description
RDY	-	OFF	Electronics power supply is missing or outside permissible tolerance range.
	Green	Steady light	The component is ready for operation and cyclic DRIVE-CLiQ communication is taking place.
	Orange	Steady light	DRIVE-CLiQ communication is being established.
	Red	Steady light	At least one fault is present in this component. <b>Note:</b> LED is driven irrespective of the corresponding messages being reconfigured.
	Green/ Red	Flashing light 2 Hz	Firmware is being downloaded.
	Green/ Orange or Red/Orange	Flashing light 2 Hz	Detection of the components via LED is activated (p0154). <b>Note:</b> Both options depend on the LED status when module recognition is activated via p0154 = 1.

### 7.2.4 Dimension drawing

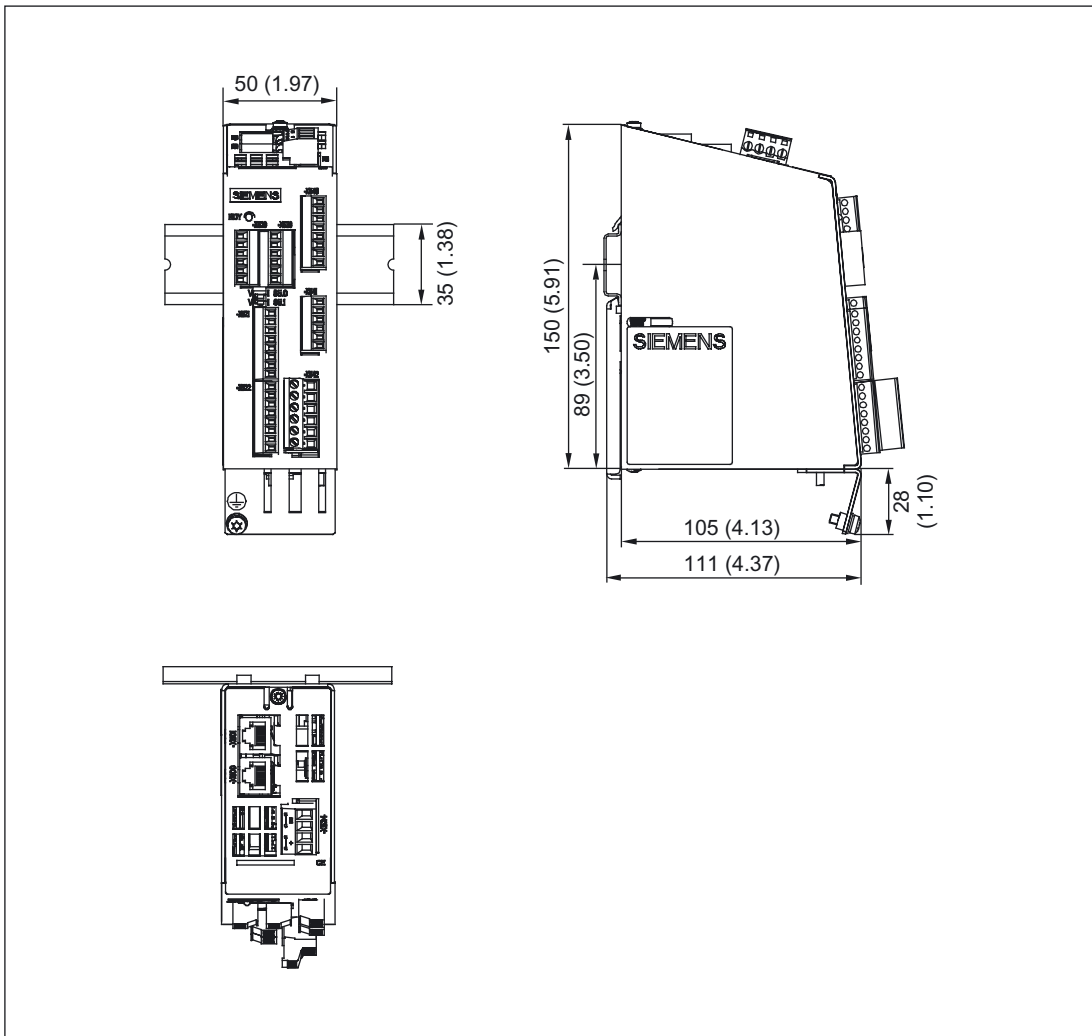

Figure 7-5 Dimension drawing of the TM31



## 7.2.5 Mounting

### Installation

1. Place the component on the DIN rail.
2. Snap the component on to the DIN rail. Make sure that the mounting slides at the rear latch into place.
3. You can now move the component on the DIN rail to the left or to the right to its final position.

### Removal

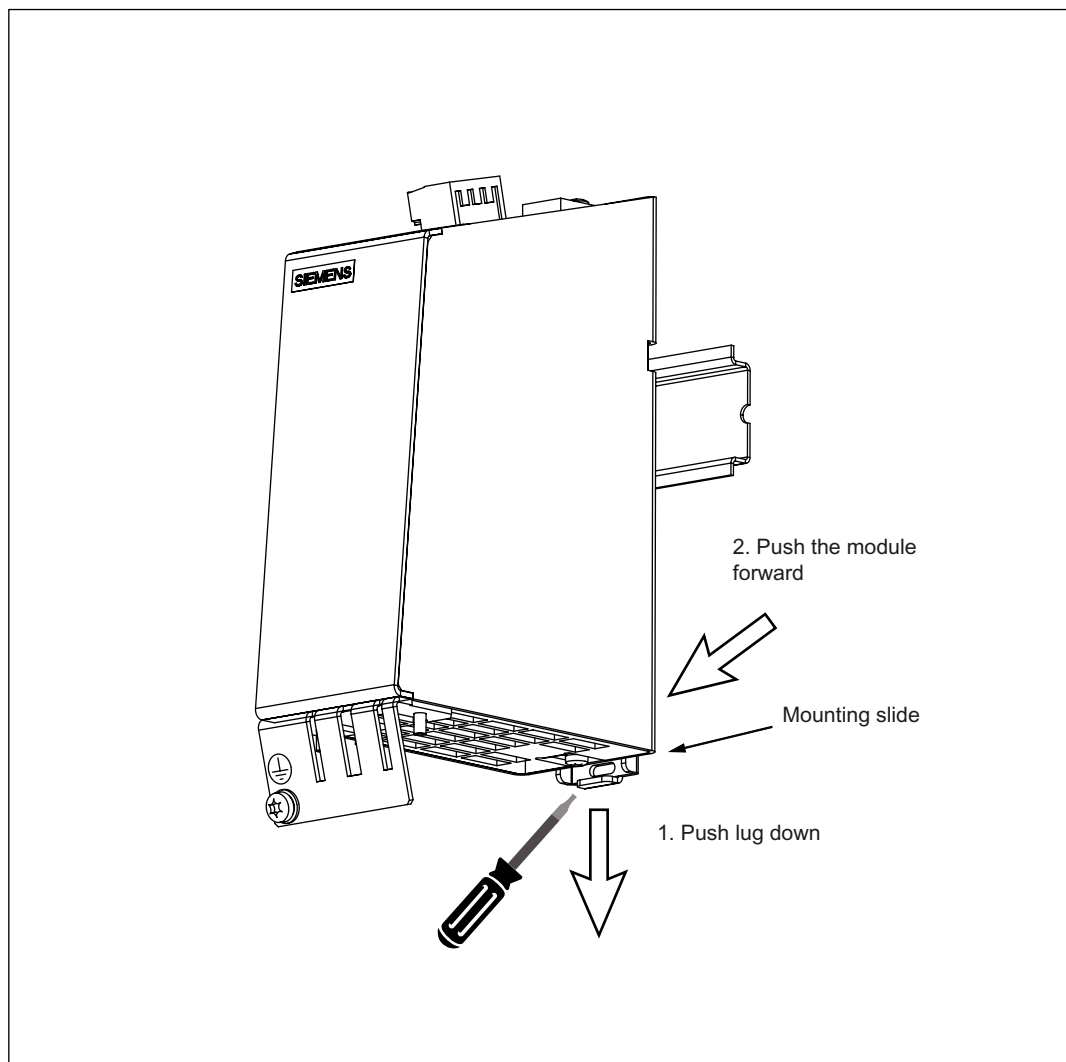

Figure 7-6 Releasing the component from a DIN rail

### 7.2.6 Electrical Connection

It is always advisable to shield the digital I/O wiring.

The following pictures show two typical shield contacts from Weidmüller.

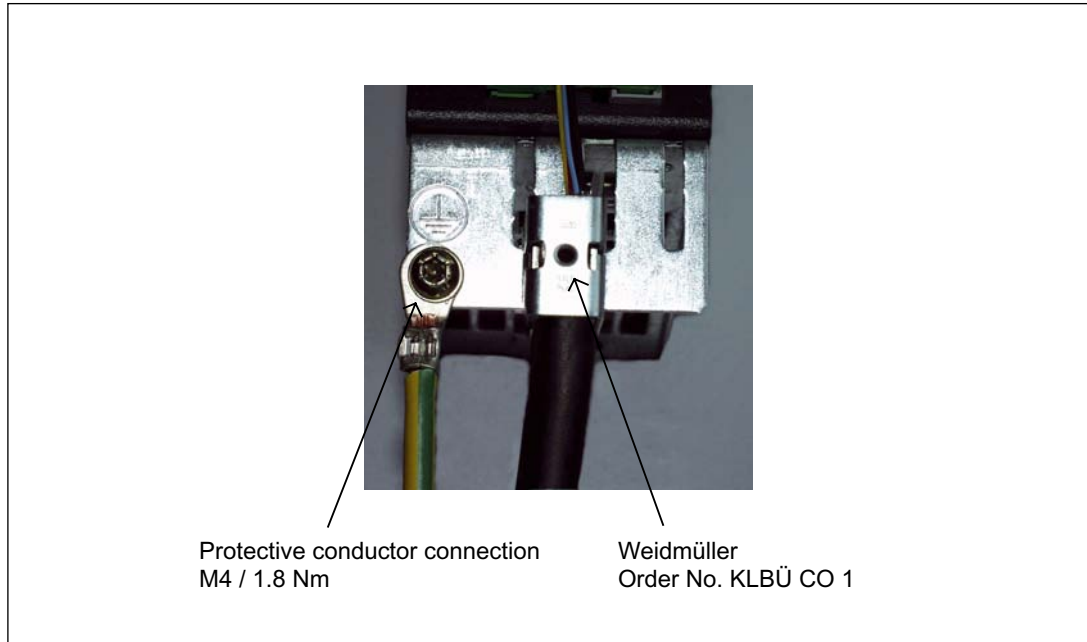

Figure 7-7 Shield contacts

#### Internet address of the company:

Weidmüller: [www.weidmueller.com](http://www.weidmueller.com)



---

#### Danger

If the shielding procedures described and the specified cable lengths are not observed, the machine may not operate properly.

---

### Connector codes

To ensure that identical connectors are assigned correctly on the TM31, the connectors are encoded as shown in the following diagram.

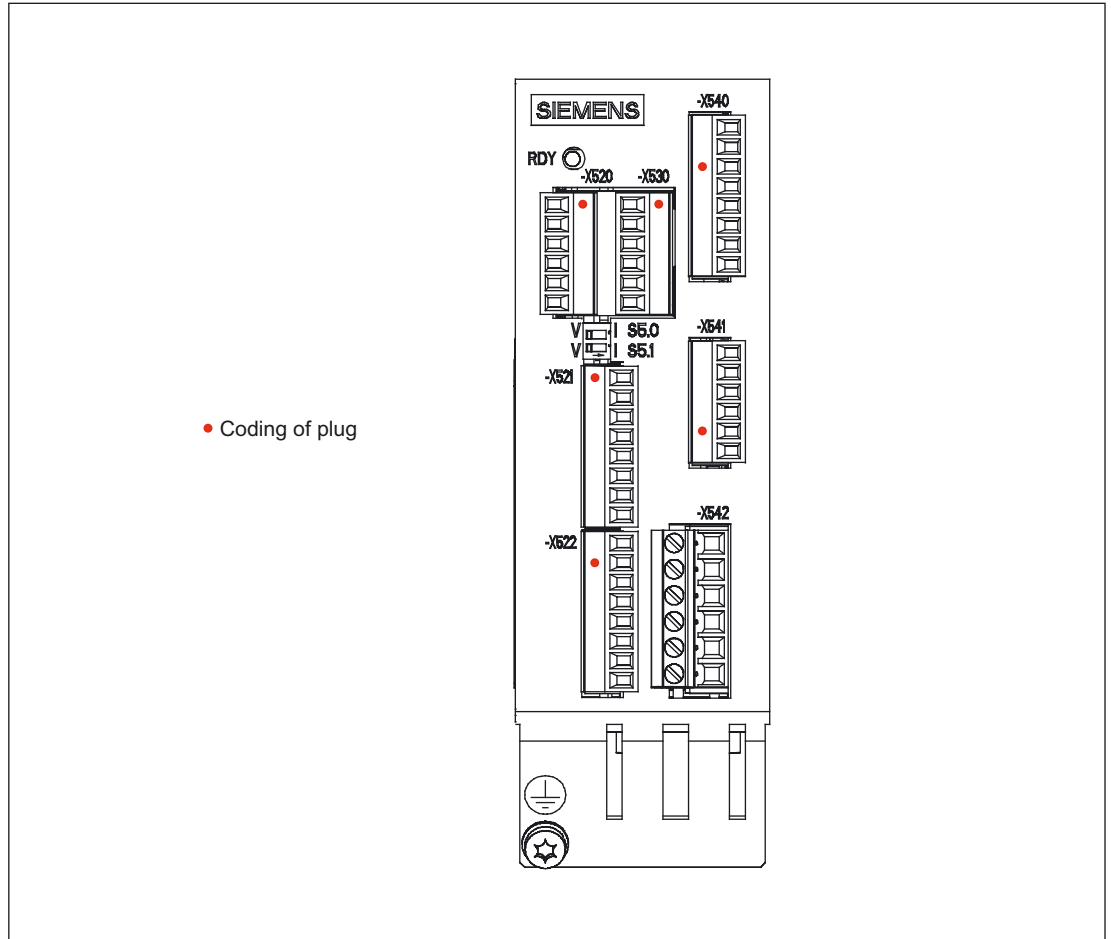

Figure 7-8 Connector codes of the TM31

The bending radii of the cables must be taken into account (see description of MOTION-CONNECT).

### 7.2.7 Technical data

Table 7-17 Technical data

	Unit	Value
Electronics power supply		
Voltage	V <sub>DC</sub>	24 DC (20.4 – 28.8)
Current (without DRIVE-CLiQ or digital outputs)	A <sub>DC</sub>	0.5
Power loss	W	<10
PE/ground connection	At the housing with M4/1.8 Nm screw	
Response time	The response time for the digital inputs/outputs and the analog inputs/outputs consists of the following elements: <ul style="list-style-type: none"> <li>• Response time on the component itself (approx. 1/2 DRIVE-CLiQ cycle).</li> <li>• Response transmit time via the DRIVE-CLiQ connection (approx. 1 DRIVE-CLiQ cycle).</li> <li>• Evaluation on the control unit (see function diagram).</li> </ul> <b>Reference:</b> SINAMICS S List Manual – "Function diagrams" chapter	
Weight	kg	1

## 7.3 Sensor Module Cabinet 10 (SMC10)

### 7.3.1 Description

The Sensor Module Cabinet-Mounted 10 (SMC10) evaluates encoder signals and transmits the speed, actual position value, rotor position and, if necessary, the motor temperature via DRIVE-CLiQ to the Control Unit.

The SMC10 can be operated from firmware 2.2 and higher

The SMC10 is used to evaluate sensor signals from resolvers.

Table 7-18 Specification

	<b>Value</b>
Transmission ratio of the resolver	$\ddot{u} = 0.5$
Exciting voltage on the SMC10 when $\ddot{u}=0.5$	4.1 Vrms
Amplitude monitoring threshold (secondary tracks) of the SMC10	1 Vrms

The excitation voltage is 4.1 V and cannot be parameterized.

The excitation frequency is synchronized to the current controller clock cycle and lies in the range between 5 kHz and 10 kHz.

The ratio between ohmic resistance R and inductance L determines whether the resolver can be evaluated with the SMC10. See the following diagram:

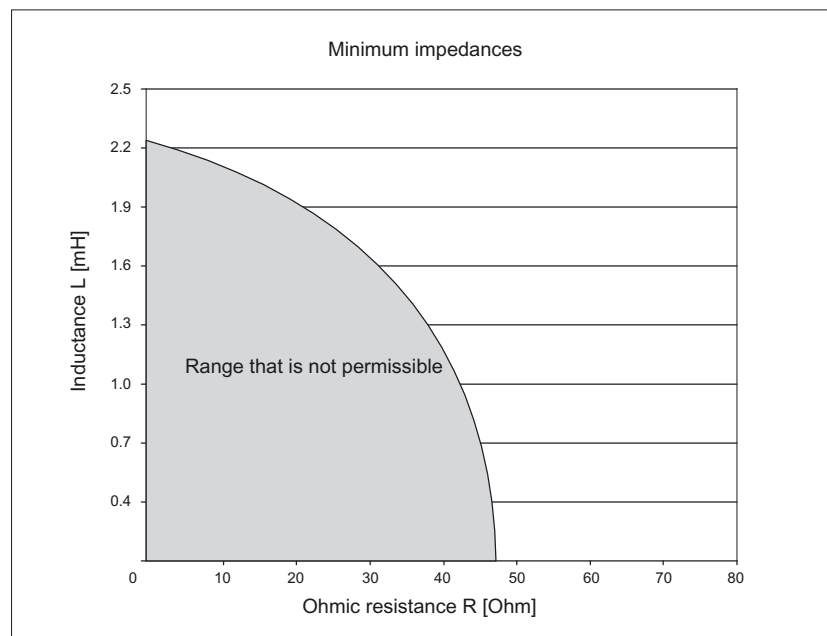

Figure 7-9 Connectable impedances with an exciting frequency  $f = 5000$  Hz

The maximum sensor cable length is 130 m.

The component is snapped on to a mounting rail according to DIN 50022.

### 7.3.2 Safety information



---

**Caution**

The cooling clearances of 50 mm above and below the components must be observed.

---

---

**Notice**

Only one measuring system can be connected to each Sensor Module.

---

---

**Note**

There may be no electrical connection between the measuring system housing and the measuring system electronics (this requirement is fulfilled for most encoder systems). If this is not carefully observed, then under certain circumstances the system will not be able to reach the required noise immunity (there is then a danger of equalization currents flowing through the electronics ground).

---

---

**Caution**

Connecting cables to temperature sensors must always be installed with shielding. The cable shield must be connected to the chassis potential at both ends over a large surface area. Temperature sensor cables that are routed together with the motor cable must be twisted in pairs and shielded separately.

---

### 7.3.3 Interface description

#### 7.3.3.1 Overview

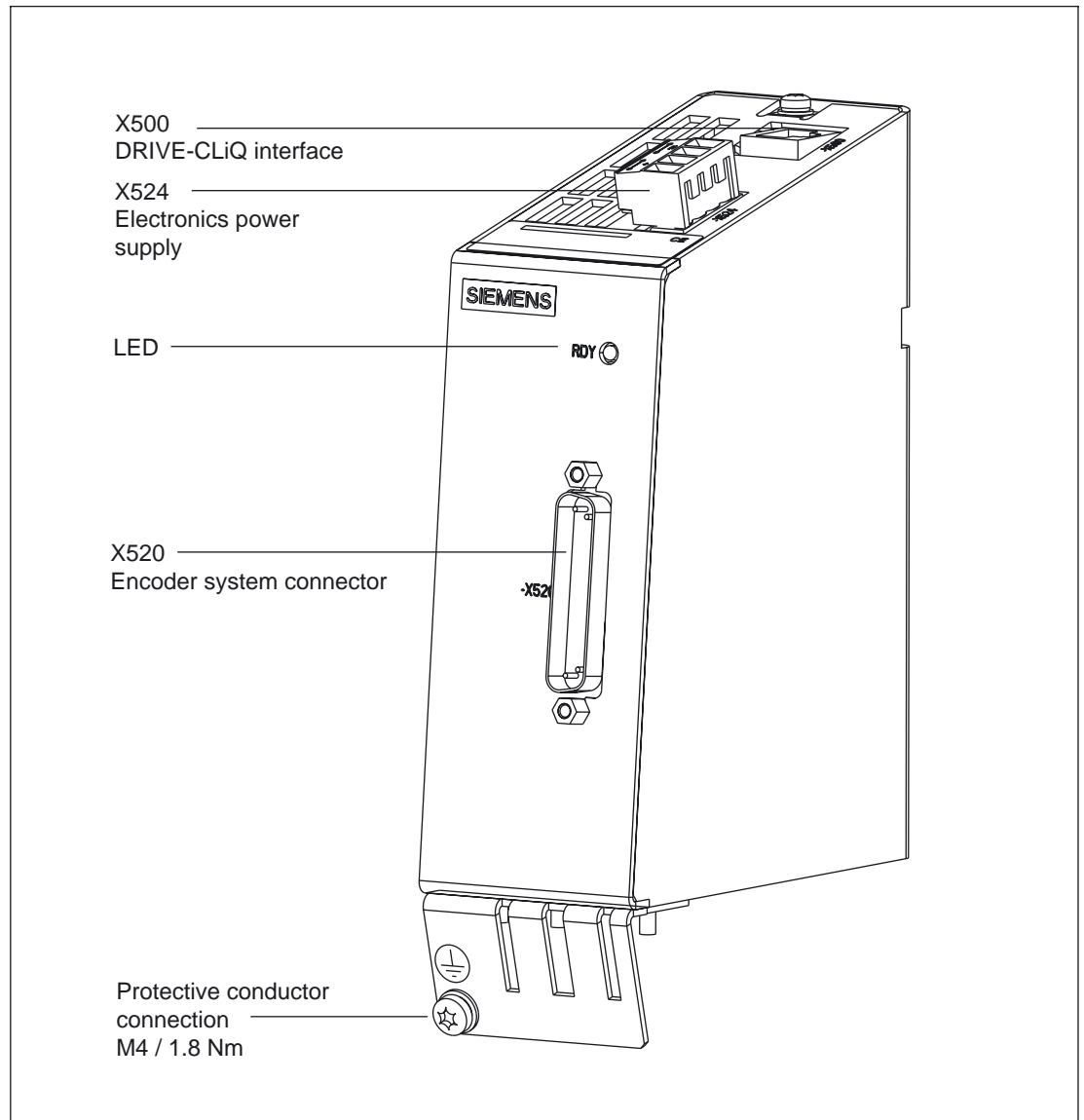
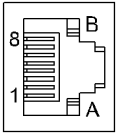

Figure 7-10 Interface description of the SMC10

7.3.3.2 DRIVE-CLiQ interface X500

Table 7-19 DRIVE-CLiQ interface X500

	Pin	Signal name	Technical specifications
	1	TXP	Transmit data +
	2	TXN	Transmit data -
	3	RXP	Receive data +
	4	Reserved, do not use	
	5	Reserved, do not use	
	6	RXN	Receive data -
	7	Reserved, do not use	
	8	Reserved, do not use	
	A	Reserved, do not use	
	B	GND (0 V)	Electronic ground



### 7.3.3.3 X520 sensor system

Table 7-20 Sensor interface X520

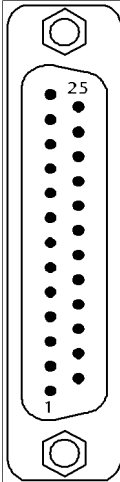
	Pin	Signal name	Technical specifications
	1	Reserved, do not use	
	2	Reserved, do not use	
	3	A (sin+)	Resolver signal A
	4	A* (sin-)	Inverted resolver signal A
	5	Ground	Ground (for internal shield)
	6	B (cos+)	Resolver signal B
	7	B* (cos-)	Inverted resolver signal B
	8	Ground	Ground (for internal shield)
	9	RESP	Resolver excitation positive
	10	Reserved, do not use	
	11	RESN	Resolver excitation negative
	12	Reserved, do not use	
	13	+Temp	Motor temperature measurement KTY+
	14	Reserved, do not use	
	15	Reserved, do not use	
	16	Reserved, do not use	
	17	Reserved, do not use	
	18	Reserved, do not use	
	19	Reserved, do not use	
	20	Reserved, do not use	
	21	Reserved, do not use	
	22	Reserved, do not use	
	23	Reserved, do not use	
	24	Ground	Ground (for internal shield)
	25	-Temp	Motor temperature measurement KTY-

### 7.3.3.4 Electronics power supply X524

Table 7-21 Terminal block X524

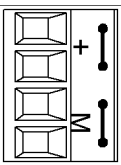
	Terminal	Function	Technical specifications
	+	Electronics power supply	Voltage: 24 V (20.4 V – 28.8 V) Current consumption: max. 0.35 A Maximum current via jumper in connector: 20 A at 55°C
	+	Electronics power supply	
	M	Electronic ground	
	M	Electronic ground	
Max. cross-section that can be connected: 2.5 mm <sup>2</sup> Type: Screw terminal 2 (see Appendix)			

**Note**

The two “+” and “M” terminals are jumpered in the connector. This ensures the supply voltage is looped through.

### 7.3.3.5 Description of the LEDs on the SMC10

Table 7-22 Description of the LEDs on the SMC10

LED	Color	State	Technical specifications
RDY	-	OFF	Electronics power supply is missing or outside permissible tolerance range.
	Green	Steady light	The component is ready for operation and cyclic DRIVE-CLiQ communication is taking place.
	Orange	Steady light	DRIVE-CLiQ communication is being established.
	Red	Steady light	At least one fault is present in this component. <b>Note:</b> LED is driven irrespective of the corresponding messages being reconfigured.
	Green/ Red	Flashing light 2 Hz	Firmware is being downloaded.
	Green/Orange or Red/Orange	Flashing light 2 Hz	Component recognition via LED is activated (p0144) <b>Note:</b> Both options depend on the LED status when component recognition is activated via p0144 = 1.

### Cause and rectification of faults

The following reference contains further information about the cause and rectification of faults:

Reference: /IH1/ SINAMICS Commissioning Manual.

### 7.3.4 Dimension drawing

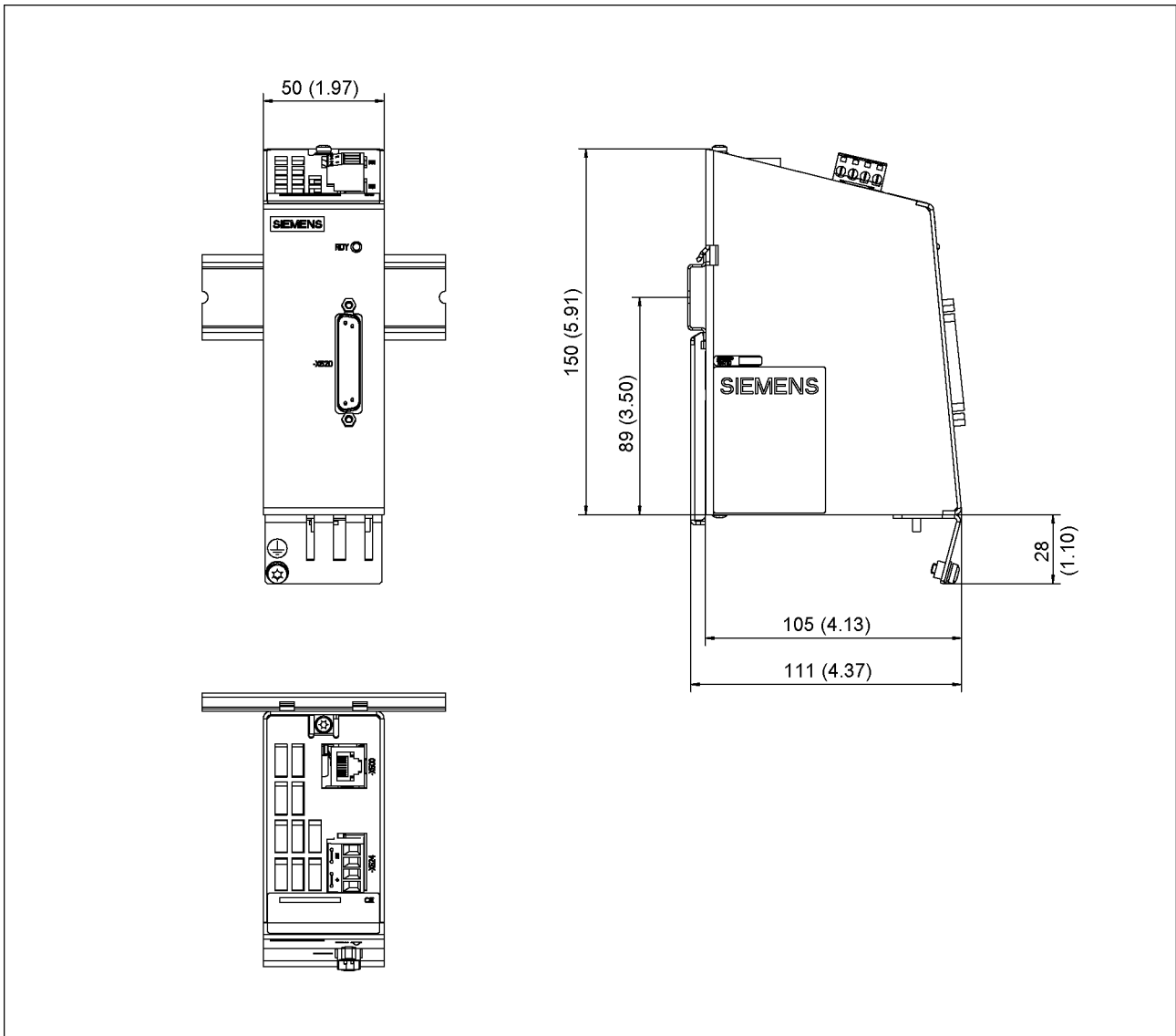

Figure 7-11 Dimension drawing of the SMC10

### 7.3.5 Mounting

#### Installation

1. Place the component on the DIN rail.
2. Snap the component on to the DIN rail. Make sure that the mounting slides at the rear latch into place.
3. You can now move the component on the DIN rail to the left or to the right to its final position.

#### Removal

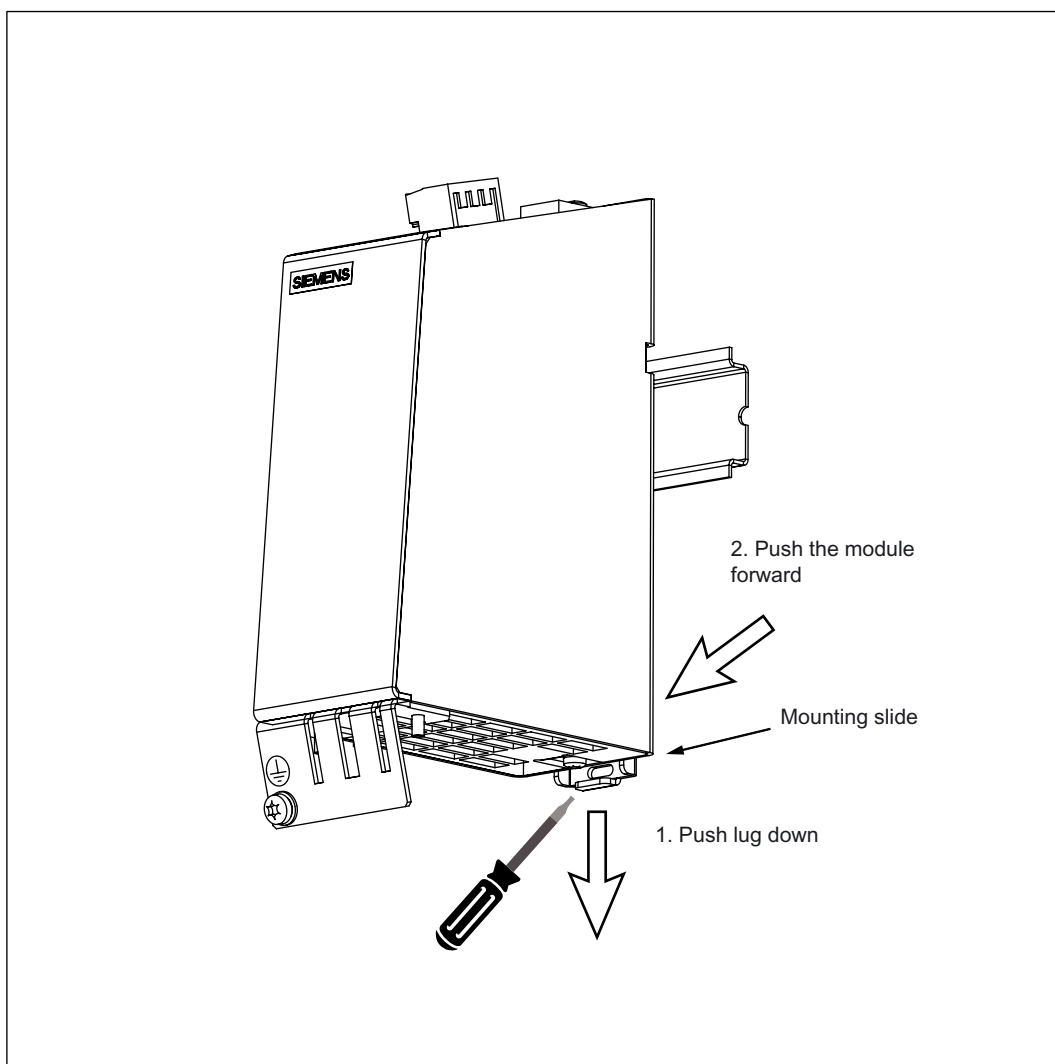

Figure 7-12 Releasing the component from a DIN rail

### 7.3.6 Technical data

Table 7-23 Technical data

	<b>Unit</b>	<b>Value</b>
Electronics power supply		
Voltage	$V_{DC}$	24 DC (20.4 – 28.8)
Current	$A_{DC}$	max. 0.3
PE/ground connection	At the housing with M4/1.8 Nm screw	
Weight	kg	0.8
Degree of protection	IP20 or IPXXB	

## 7.4 Sensor Module Cabinet 20 (SMC20)

### 7.4.1 Description

The Sensor Module Cabinet-Mounted 20 (SMC20) evaluates encoder signals and transmits the speed, actual position value, rotor position and, if necessary, the motor temperature and reference point via DRIVE-CLiQ to the Control Unit.

Encoders that can be connected are incremental SIN/COS (1 Vpp) and absolute encoders with EnDat and SSI (with 5 V operating voltage).

The maximum sensor cable length is 100 m.

The component is snapped on to a mounting rail according to DIN 50022.

The SMC20 can be operated from Firmware 2.2 onwards

### 7.4.2 Safety Information



---

#### Caution

The cooling clearances of 50 mm above and below the components must be observed.

---

---

#### Notice

Only one measuring system can be connected to each Sensor Module.

---

---

#### Note

There may be no electrical connection between the measuring system housing and the measuring system electronics (this requirement is fulfilled for most encoder systems). If this is not carefully observed, then under certain circumstances the system will not be able to reach the required noise immunity (there is then a danger of equalization currents flowing through the electronics ground).

---

---

#### Caution

Connecting cables to temperature sensors must always be installed with shielding. The cable shield must be connected to the chassis potential at both ends over a large surface area. Temperature sensor cables that are routed together with the motor cable must be twisted in pairs and shielded separately.

---

### 7.4.3 Interface description

#### 7.4.3.1 Overview

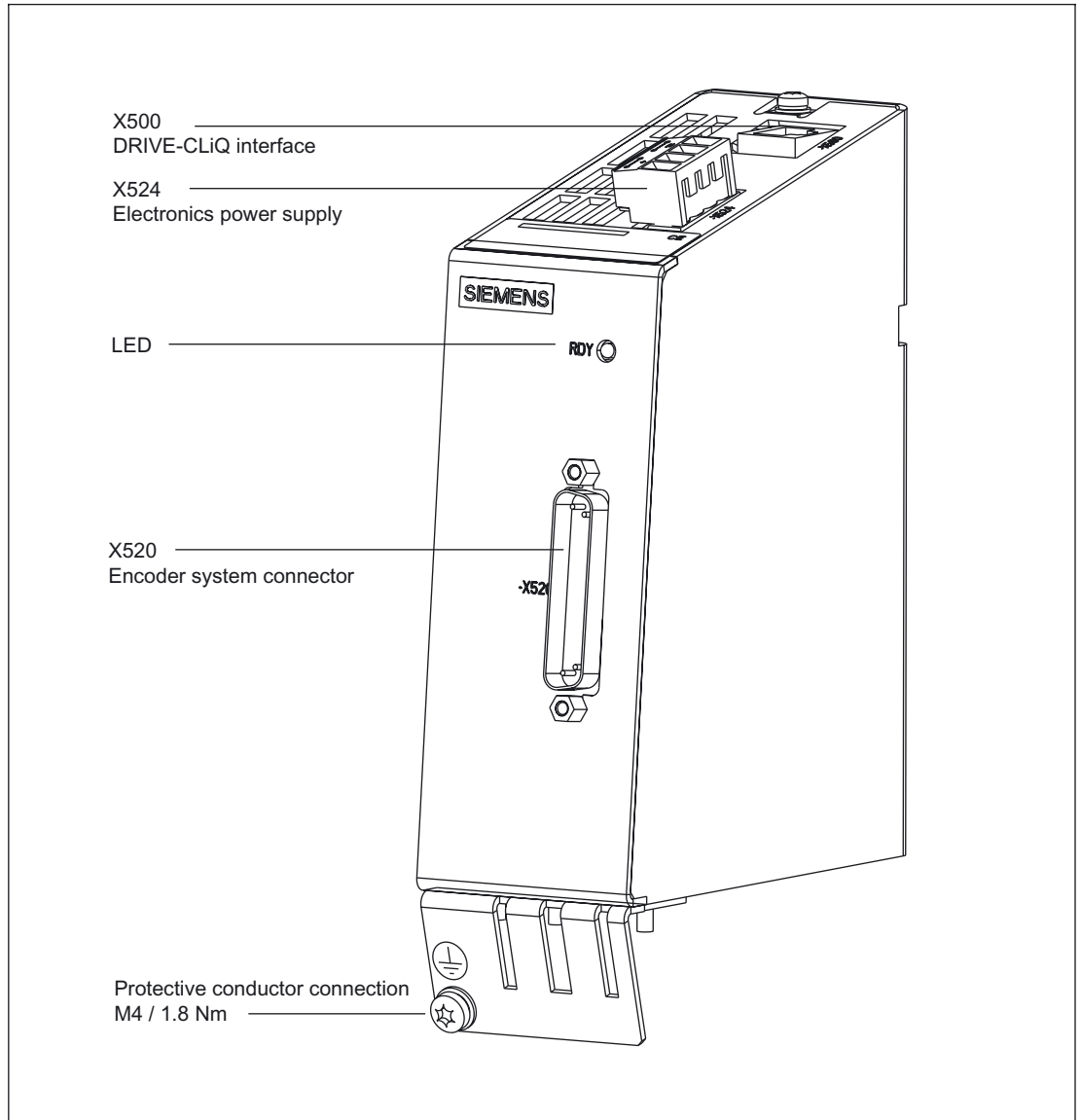
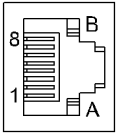

Figure 7-13 Interface description of the SMC20

7.4.3.2 DRIVE-CLiQ interface X500

Table 7-24 DRIVE-CLiQ interface X500

	Pin	Signal name	Technical specifications
	1	TXP	Transmit data +
	2	TXN	Transmit data -
	3	RXP	Receive data +
	4	Reserved, do not use	
	5	Reserved, do not use	
	6	RXN	Receive data -
	7	Reserved, do not use	
	8	Reserved, do not use	
	A	Reserved, do not use	
	B	GND (0 V)	Electronic ground



### 7.4.3.3 X520 sensor system

Table 7-25 Sensor interface X520

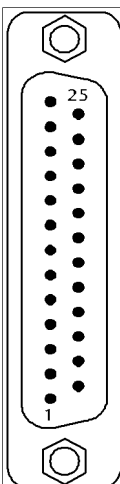
	Pin	Signal name	Technical specifications
	1	P encoder	Encoder power supply
	2	M encoder	Ground for encoder power supply
	3	A	Resolver signal A
	4	A*	Inverted resolver signal A
	5	Ground	Ground (for internal shield)
	6	B	Resolver signal B
	7	B*	Inverted resolver signal B
	8	Ground	Ground (for internal shield)
	9	Reserved, do not use	
	10	EnDat_Clock, SSI_Clock	Clock, EnDat interface, SSI clock <sup>1)</sup>
	11	Reserved, do not use	
	12	EnDat_Clock*, SSI_Clock*	Inverted clock, EnDat interface, Inverted SSI clock <sup>1)</sup>
	13	+Temp	Motor temperature measurement KTY+/PTC
	14	5 V Sense	Sense input encoder power supply
	15	EnDat_Data, SSI_Data	Data, EnDat interface, SSI data <sup>1)</sup>
	16	0 V Sense	Ground sense input encoder power supply
	17	R	Reference signal R
	18	R*	Inverted reference signal R
	19	C	Absolute track signal C
	20	C*	Inverted absolute value signal C
	21	D	Absolute track signal D
	22	D*	Inverted absolute track signal D
	23	EnDat_Data*, SSI_Data*	Inverted data, EnDat interface, Inverted SSI data
	24	Ground	Ground (for internal shield)
	25	-Temp	Motor temperature measurement KTY-/PTC

<sup>1)</sup> Only from Firmware 2.4 onwards

### 7.4.3.4 Electronics power supply X524

Table 7-26 Terminal block X524

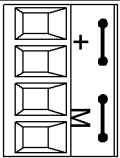
	Terminal	Function	Technical specifications
	+	Electronics power supply	Voltage: 24 V (20.4 V – 28.8 V) Current consumption: max. 0.35 A Maximum current via jumper in connector: 20 A at 55°C
	+	Electronics power supply	
	M	Electronic ground	
	M	Electronic ground	
Max. cross-section that can be connected: 2.5 mm <sup>2</sup> Type: Screw terminal 2 (see Appendix A)			

**Note**

The two “+” and “M” terminals are jumpered in the connector. This ensures the supply voltage is looped through.

### 7.4.3.5 Description of the LEDs on the SMC20

Table 7-27 Description of the LEDs on the SMC20

LED	Color	State	Technical specifications
RDY	-	OFF	Electronics power supply is missing or outside permissible tolerance range.
	Green	Steady light	The component is ready for operation and cyclic DRIVE-CLiQ communication is taking place.
	Orange	Steady light	DRIVE-CLiQ communication is being established.
	Red	Steady light	At least one fault is present in this component. <b>Note:</b> LED is driven irrespective of the corresponding messages being reconfigured.
	Green/ Red	Flashing light 2 Hz	Firmware is being downloaded.
	Green/Orange or Red/Orange	Flashing light 2 Hz	Component recognition via LED is activated (p0144) <b>Note:</b> Both options depend on the LED status when component recognition is activated via p0144 = 1.

#### Cause and rectification of faults

The following reference contains further information about the cause and rectification of faults:

Reference: /IH1/ SINAMICS Commissioning Manual.

### 7.4.4 Dimension drawing

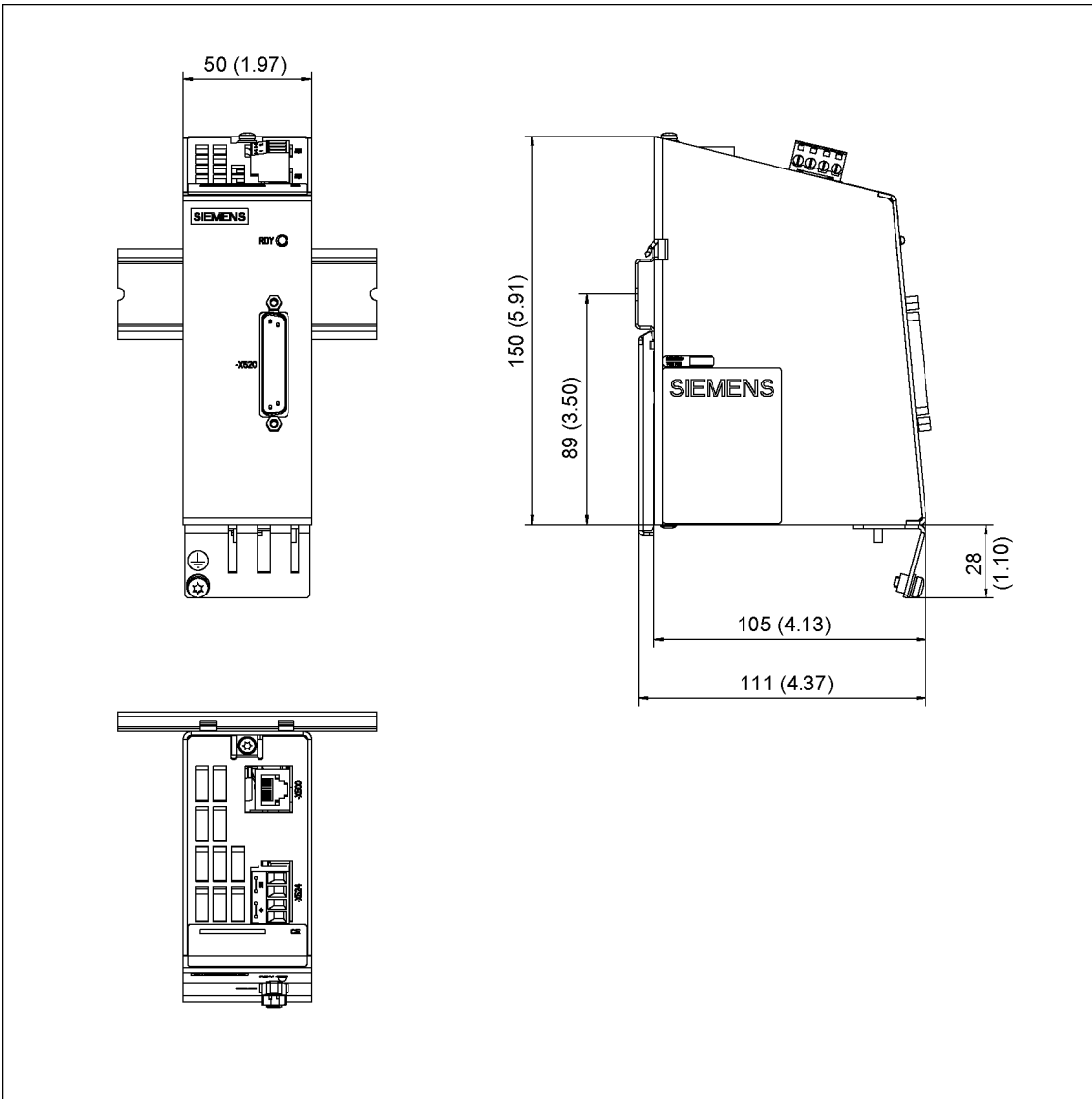

Figure 7-14 Dimension drawing of the SMC20

## 7.4.5 Mounting

### Installation

1. Place the component on the DIN rail.
2. Snap the component on to the DIN rail. Make sure that the mounting slides at the rear latch into place.
3. You can now move the component on the DIN rail to the left or to the right to its final position.

### Removal

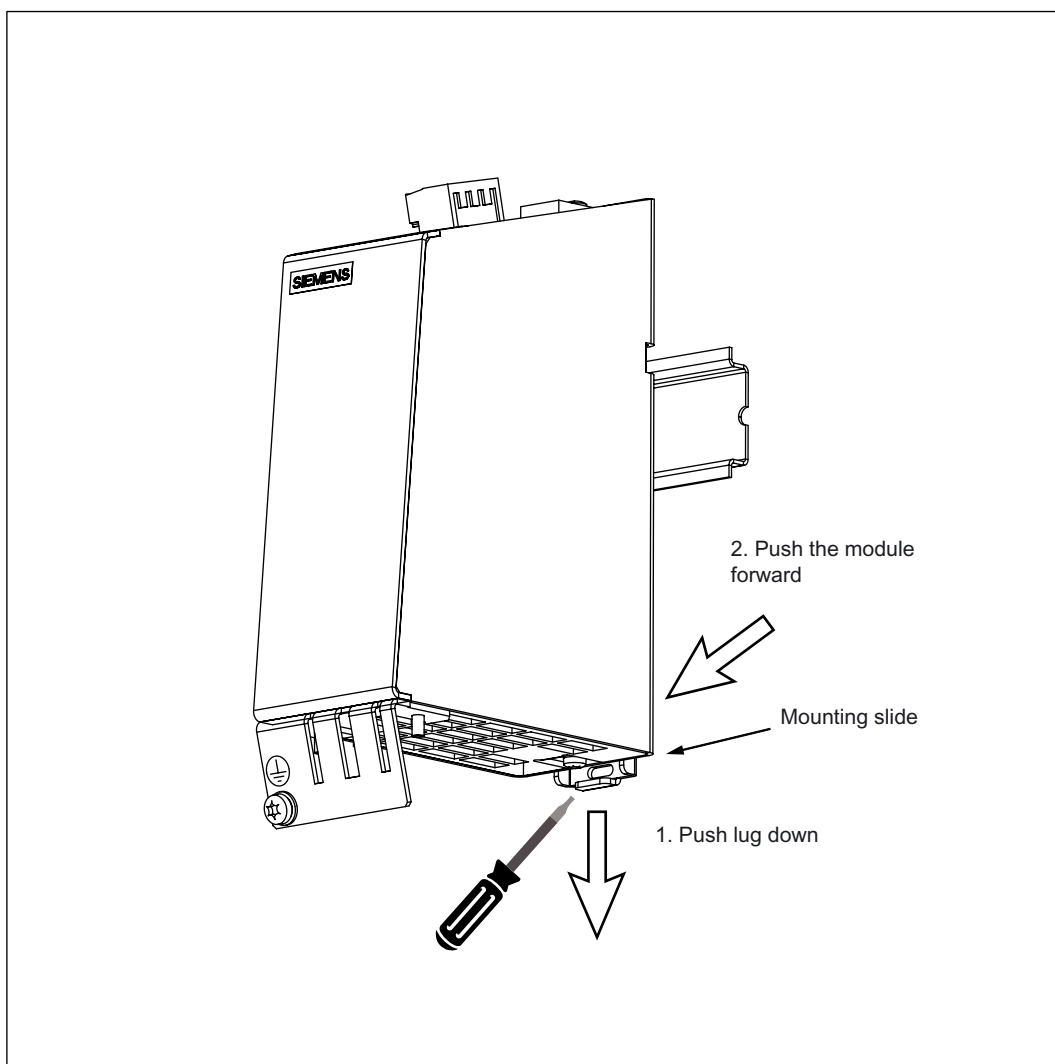

Figure 7-15 Releasing the component from a DIN rail

## 7.4.6 Technical data

Table 7-28 Technical data

	Unit	Value
Electronics power supply		
Voltage	V <sub>DC</sub>	24 V DC (20.4 – 28.8)
Current	A <sub>DC</sub>	Max. 0.4
Power loss	W	<10
PE/ground connection	At the housing with M4/1.8 Nm screw	
Weight	kg	0.8

Table 7-29 Max. frequency that can be evaluated (speed)

Resolver		Max. speed resolver / motor		
Number of poles	Number of pole pairs	8kHz / 125 µsec	4kHz / 250 µsec	2kHz / 500 µsec
2-pole	1	120,000 RPM	60,000 RPM	30,000 RPM
4-pole	2	60,000 RPM	30,000 RPM	15,000 RPM
6-pole	3	40,000 RPM	20,000 RPM	10,000 RPM
8-pole	4	30,000 RPM	15,000 RPM	7,500 RPM

## 7.5 Option modules, brake control

### 7.5.1 Introduction

An option module brake control is required for operating motors with holding brakes.

The option module brake control provides the electrical interface between the CU/PM340 and the brake of a motor. Two versions are available:

1. Brake Relay
2. Safe Brake Relay

This is mounted in the Screening Kit (refer to the Chapter "Screening Kit") or alternatively at the rear cabinet panel.

### 7.5.2 Brake Relay

#### 7.5.2.1 Description

The Brake Relay in conjunction with Power Modules, Blocksize format, can be used to control a motor brake.

Using the Brake Relay, both 24 V DC as well as 1-ph. 240 V AC brakes can be operated.

The integrated relay is controlled from the Control Unit. The electrically isolated NC contact is connected through a two-pole terminal.

The Brake Relay has the following interfaces:

Table 7-30 Overview of the Brake Relay interfaces

Type	Number
Switch contact (NO contact) to control the motor brake solenoid	1
Connection for the pre-fabricated (CTRL) to the Power Module, Blocksize format	1

The supplied brake relay includes the cable harness for connection with the power module.

### 7.5.2.2 Interface description

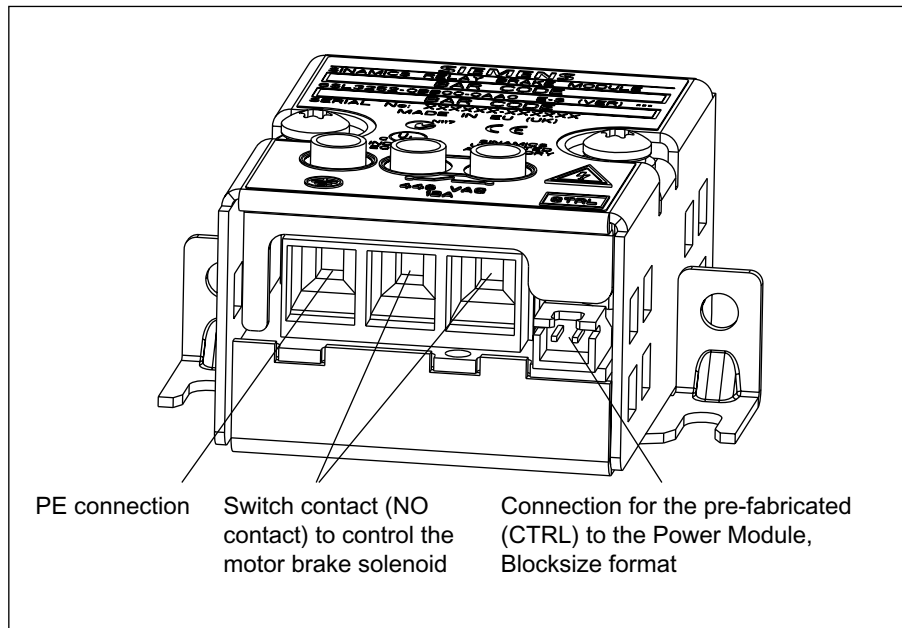

Figure 7-16 Interface description: Brake Relay

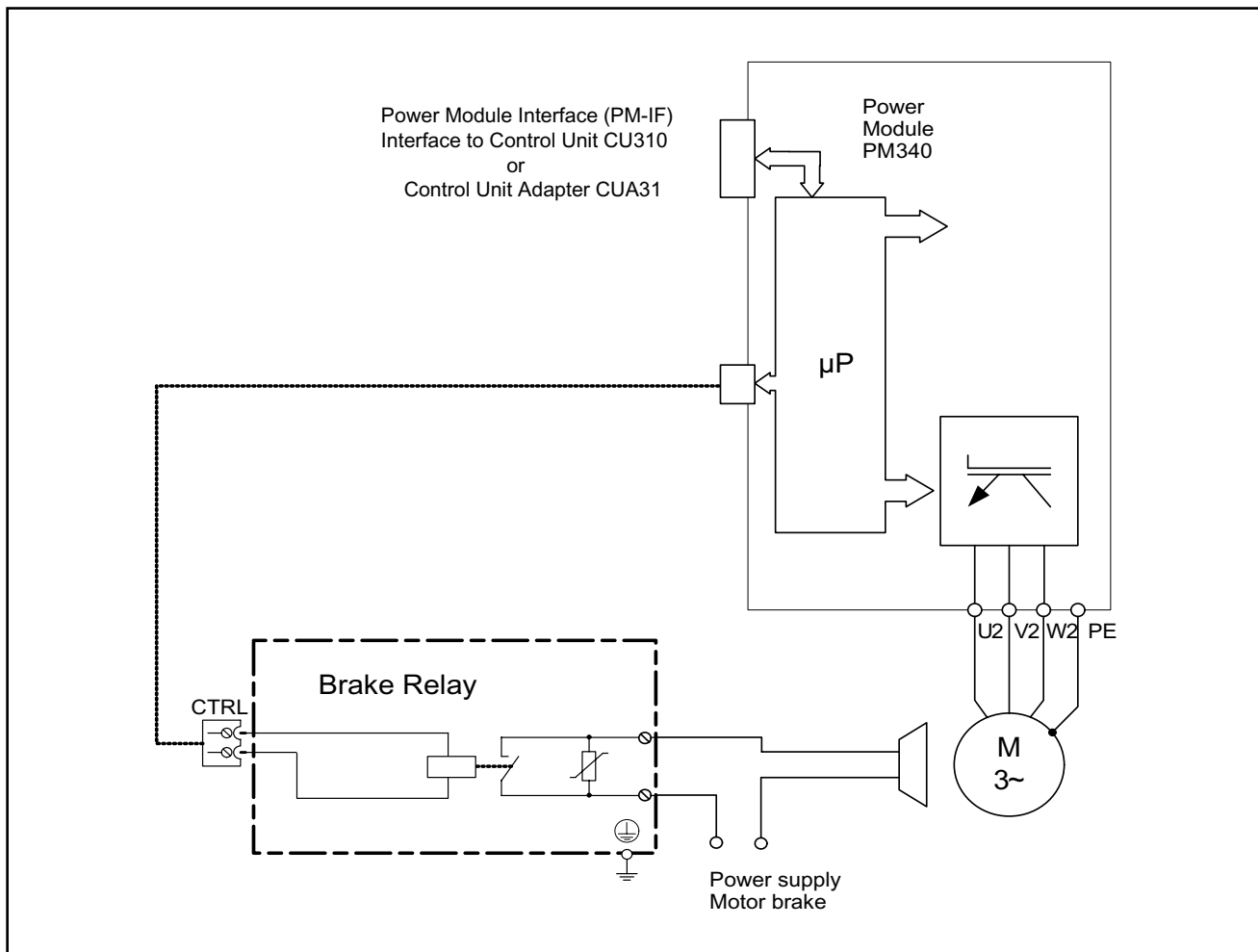
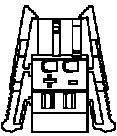

Figure 7-17 Connection example: Brake Relay

### Brake connection

Table 7-31 Terminal block

	Terminal	Technical specifications
	+ (BR+)	Brake connection
	- (BR-)	



### 7.5.2.3 Dimension drawing

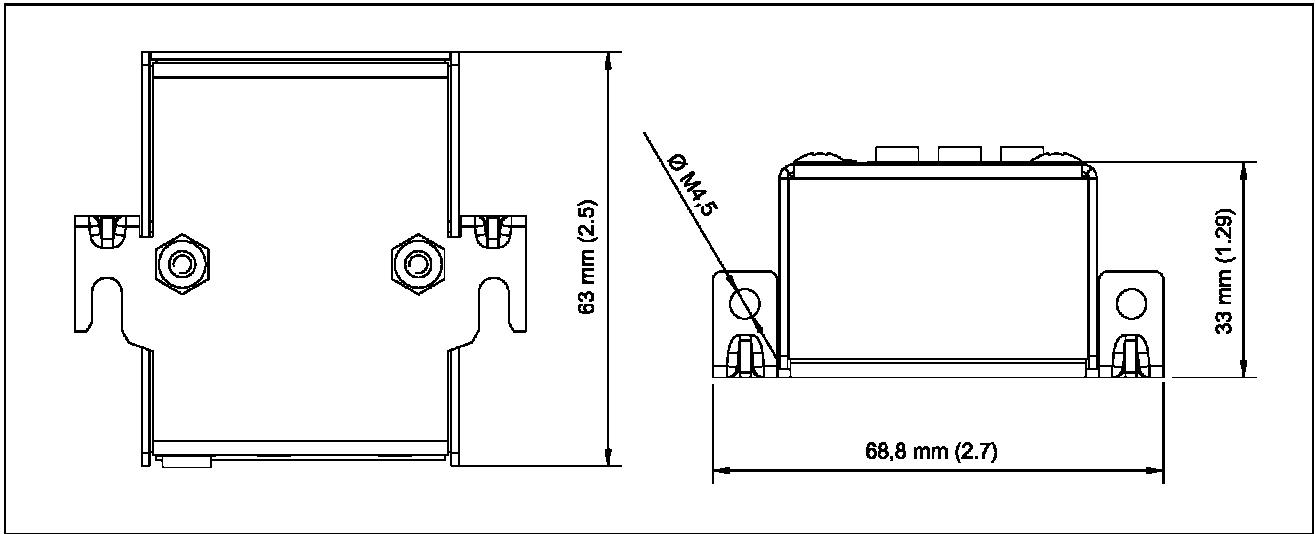

Figure 7-18 Dimension drawing: Brake Relay

### 7.5.2.4 Technical data

Table 7-32 Technical data

<b>Brake Relay</b>	
Switching capability of the NO contact	Max. 250 V <sub>AC</sub> / 12 A 24 V DC / xx A
Max. cross-section that can be connected	2.5 mm <sup>2</sup>
Weight, approx.	0.16 kg

### 7.5.3 Safe Brake Relay

The Safe Brake Relay in conjunction with Power Modules of the Blocksize format can be used to trigger a 24 V DC motor brake.

The brake is electronically controlled. All holding brakes can be used up to 2 A. To operate the brake, it is necessary to connect the power supply voltage for the brake separately at the option module brake control. In this case, a regulated power supply is necessary whose rated value of 26 V should be able to be set, e.g. SITOP modular.

Table 7-33 Overview of the Safe Brake Relay interfaces

Type	Number
Connection for the solenoid of the motor brake	1
Connection for a 24 V DC power supply	1
Connection for the pre-fabricated (CTRL) to the Power Module, Blocksize format	1

The Safe Brake Relay includes the pre-fabricated cable to connect to the Power Module and all of the customer connectors.

#### 7.5.3.1 Safety Information

---

##### Note

A regulated DC power supply is required to operate motors with a built-in holding brake. The voltage is supplied via the internal 24 V busbars. The voltage tolerances of the motor holding brakes and the voltage drops of the connection cables must be taken into account.

The DC power supply should be set to 26 V. This ensures that the voltage supply for the brake remains within the permissible range when the following conditions are fulfilled:

- Using Siemens three-phase motors
  - Using Siemens MOTION-CONNECT power cables
  - Motor cable lengths: max. 100 m
-

### 7.5.3.2 Interface description

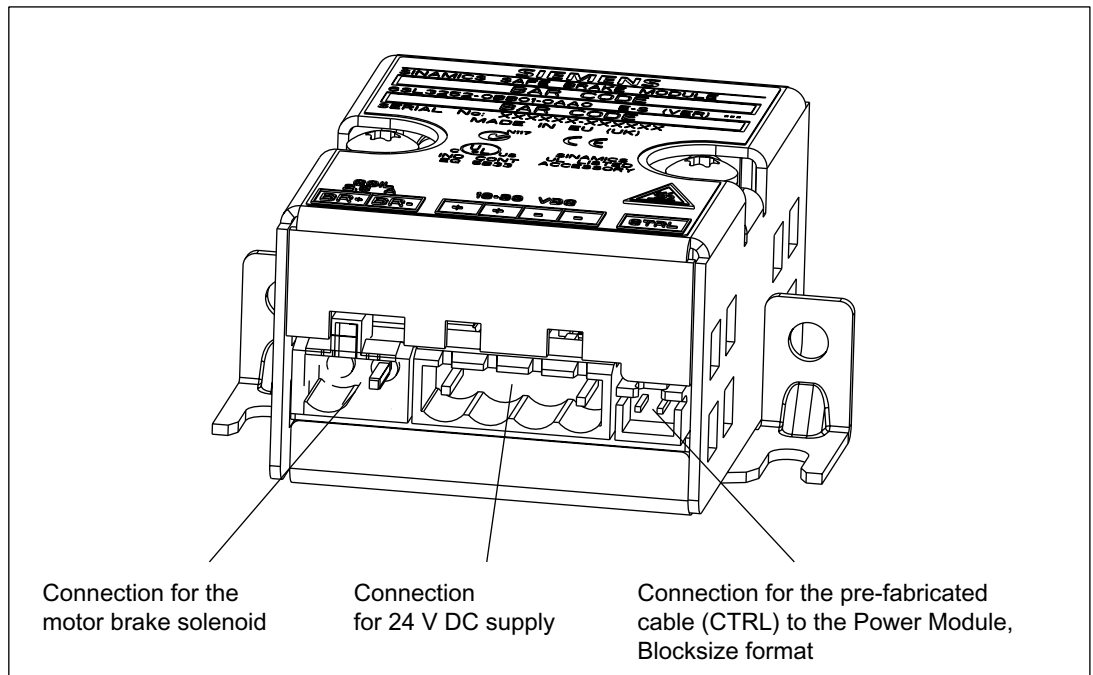

Figure 7-19 Interface description: Safe Brake Relay

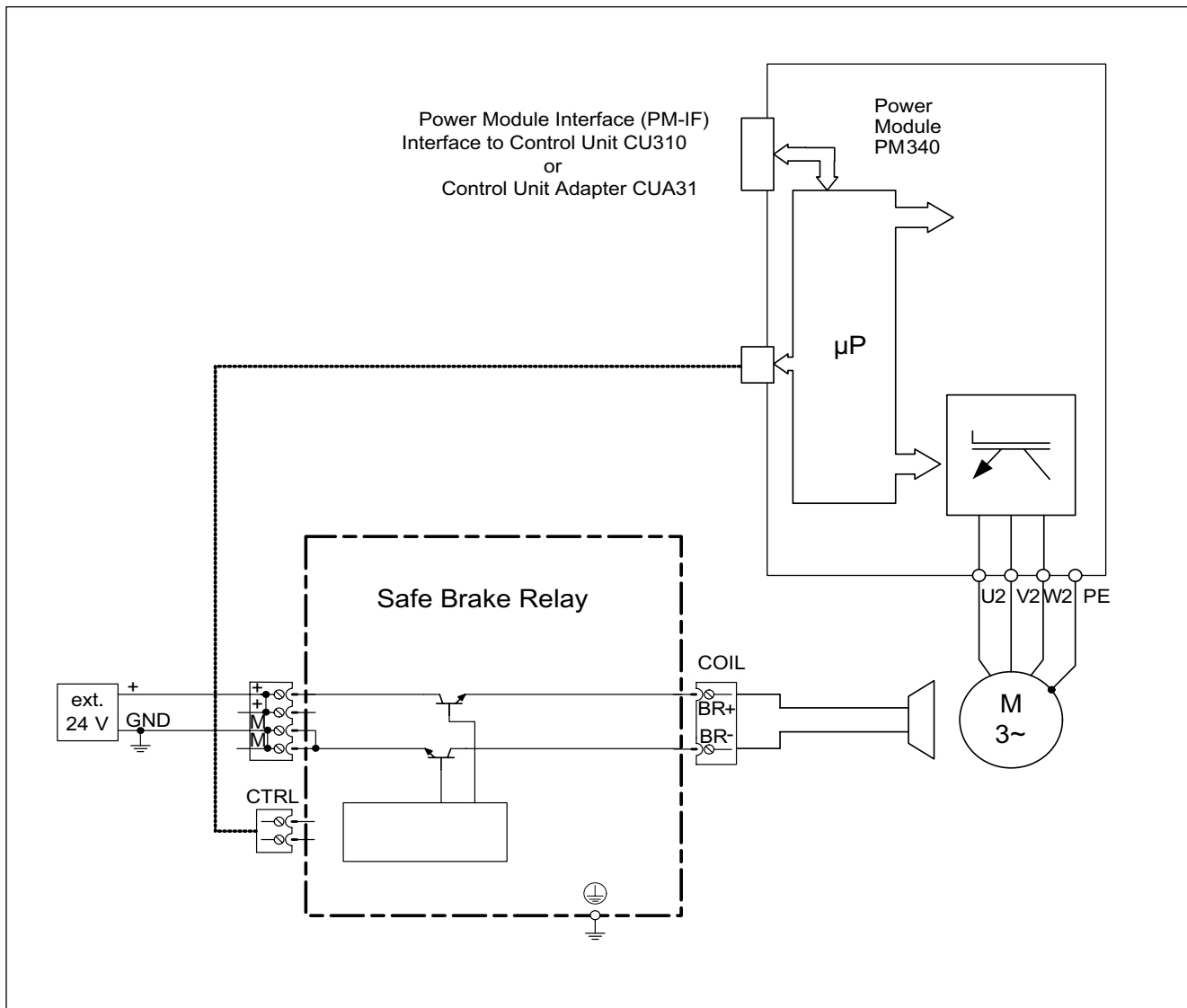
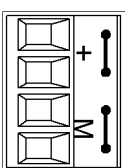

Figure 7-20 Connection example: Safe Brake Relay

## Electronics power supply X524

Table 7-34 Terminal block X524

	Terminal	Function	Technical specifications
	+	Electronics power supply	Voltage: 24 V (20.4 V – 28.8 V)
	+	Electronics power supply	
	M	Electronic ground	
	M	Electronic ground	
Max. cross-section that can be connected: 2.5 mm <sup>2</sup> Type: Screw terminal 2 (see Appendix)			

### Note

The two “+” and “M” terminals are jumpered in the connector. This ensures the supply voltage is looped through.

## Brake connection

Table 7-35 Terminal block

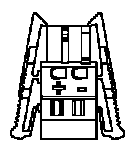
	Terminal	Technical specifications
	+ (BR+)	Brake connection
	- (BR-)	

7.5.3.3 Dimension drawing

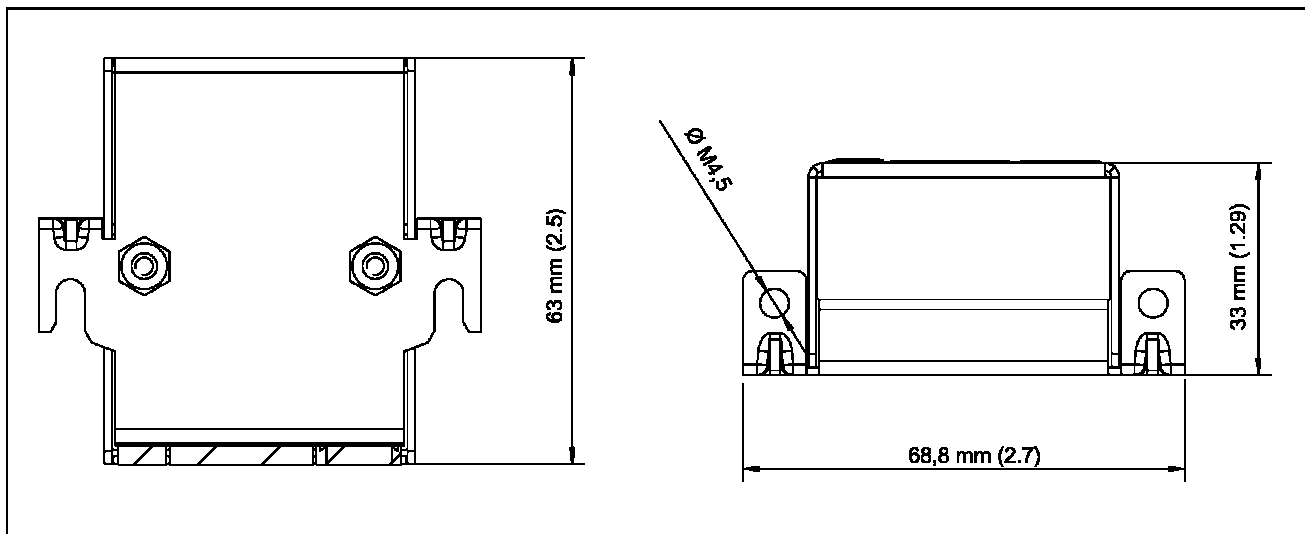

Figure 7-21 Dimension drawing: Safe Brake Relay

### 7.5.3.4 Mounting

The Safe Brake Relay can be mounted below the Power Module on the Screening Kit.

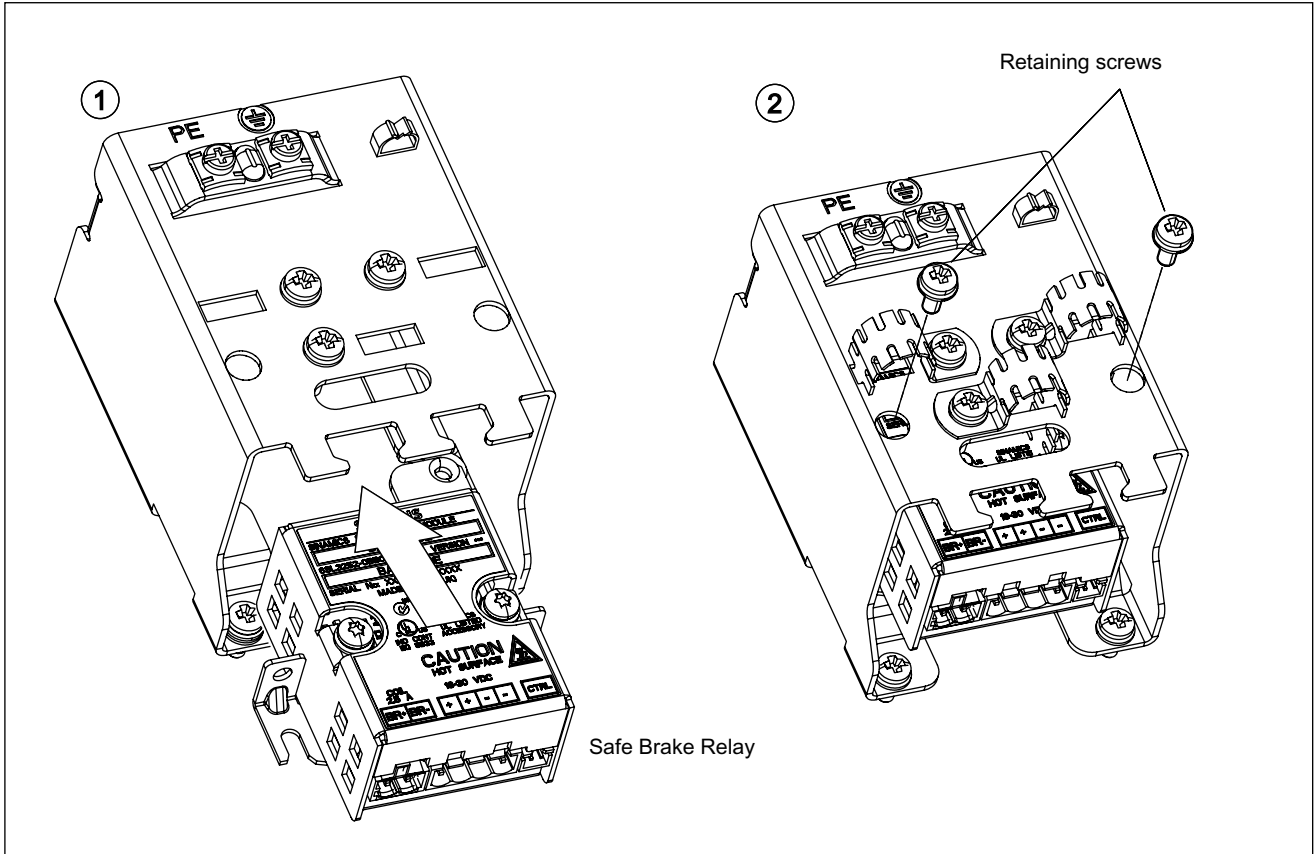

Figure 7-22 Mounting the Safe Brake Relay on the Screening Kit (frame size A)

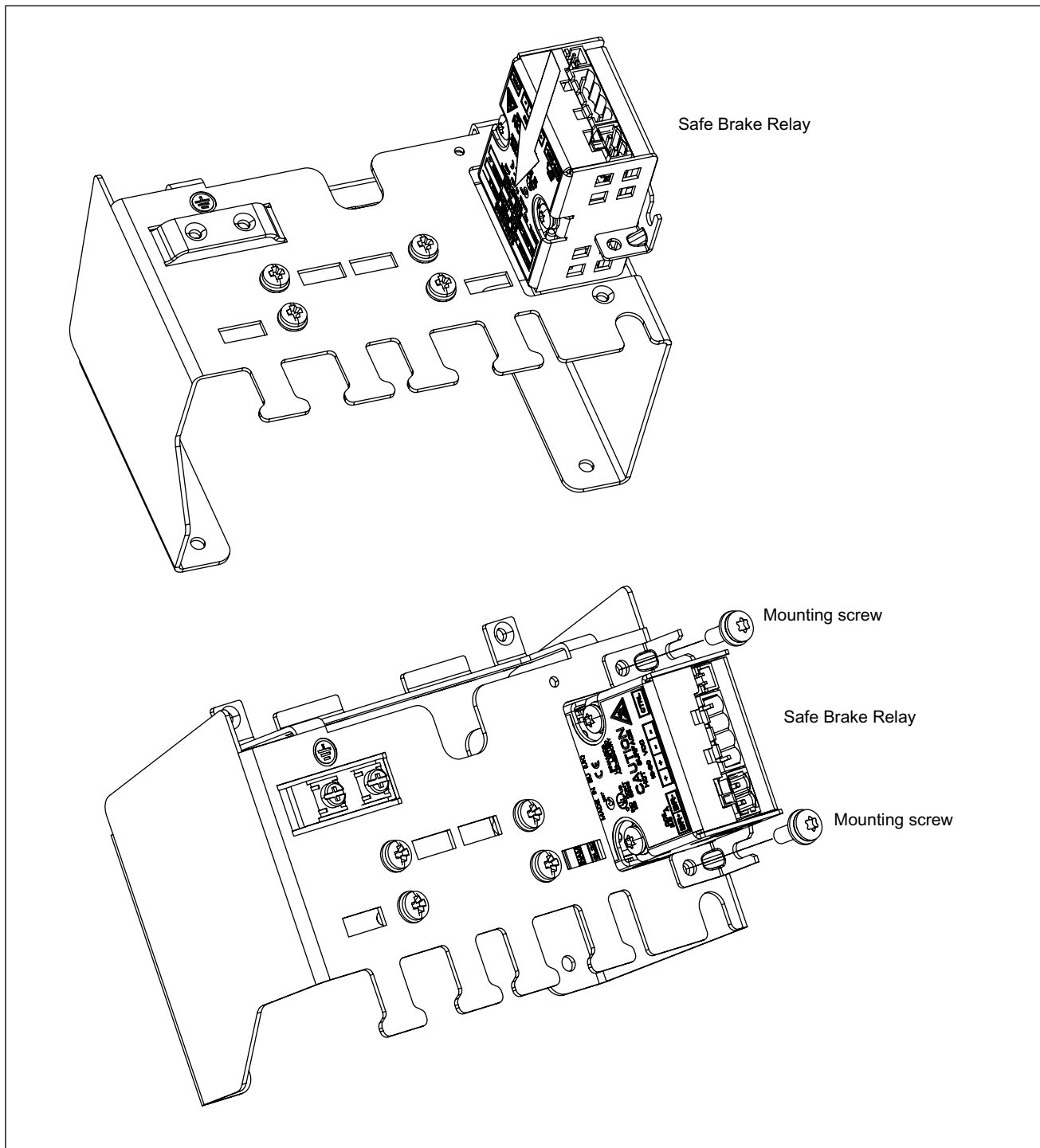

Figure 7-23 Mounting the Safe Brake Relay on the Screening Kit (frame sizes B and C)



### 7.5.3.5 Technical data

<b>Safe Brake Relay</b>	
Power supply voltage	20.4 ... 28.8 V DC Recommended nominal value of the power supply voltage 26 V DC (to equalize and compensate for the voltage drop along the feeder cable to the 24 V DC solenoid of the motor brake)
Max. permissible current drain of the motor brake	2 A
Max. current requirements (at 24 V DC)	0.3 A + the current drain of the motor brake
Max. cross-section that can be connected	2.5 mm <sup>2</sup>
Weight, approx.	0.17 kg



## Accessories

### 8.1 DRIVE-CLiQ cabinet gland

#### 8.1.1 Description

The DRIVE-CLiQ cabinet gland is used to connect two DRIVE-CLiQ cables and can be installed in a cabinet panel.

At the interface outside the cabinet, a DRIVE-CLiQ connection is implemented with degree of protection IP67 acc. to EN 60529; however, on the other hand inside the cabinet, a connection with degree of protection IP20 or IPXXB acc. to EN 60529. The interface between the cabinet panel and DRIVE-CLiQ cabinet gland should have degree of protection IP54 acc. to EN 60529.

In addition to the data lines, the power supply contacts of DRIVE-CLiQ are also routed via the coupling.

#### 8.1.2 Safety Information

---

**Note**

Only Siemens cables should be used for DRIVE-CLiQ connections.

---

### 8.1.3 Interface description

#### 8.1.3.1 Overview

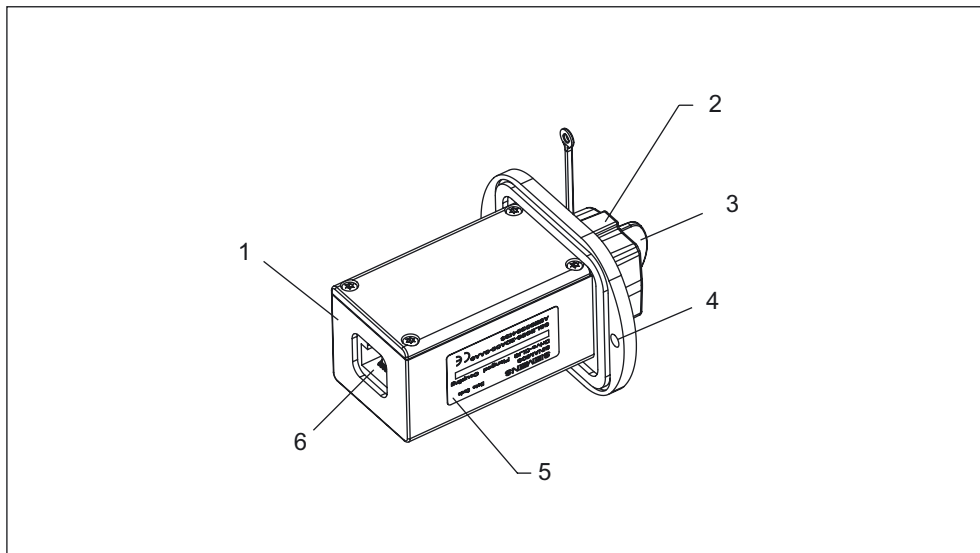

Figure 8-1 DRIVE-CLiQ cabinet gland

1	DRIVE-CLiQ cabinet gland
2	Protective cap
3	IP67 acc. to EN 60529 interface
4	Mounting holes
5	Type plate
6	IP20 or IPXXB acc. to EN 60529 interface

## 8.1.4 Dimension drawing

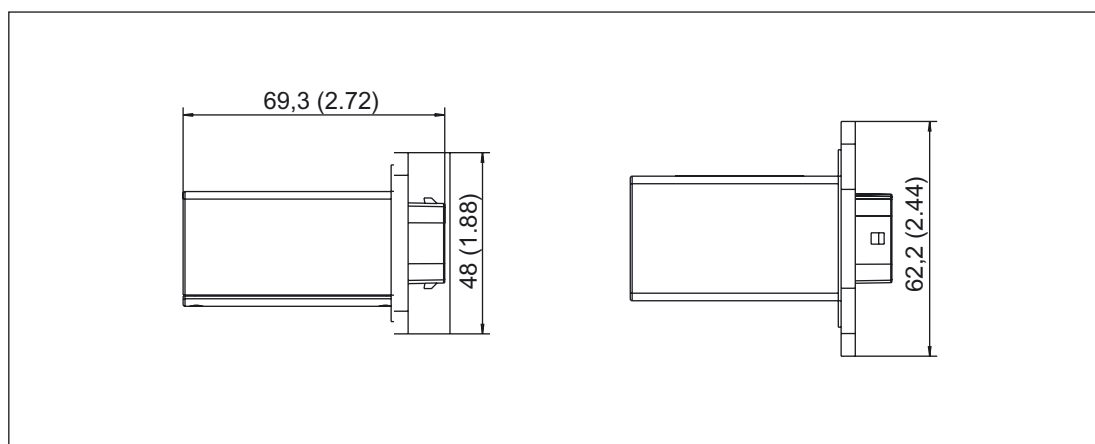

Figure 8-2 Dimension drawing, DRIVE-CLiQ cabinet gland

Accessories	B [mm]	T [mm]	H [mm]
DRIVE-CLiQ cabinet gland (with seal)	69.3 (2.72)	62.2 (2.44)	48 (1.88)

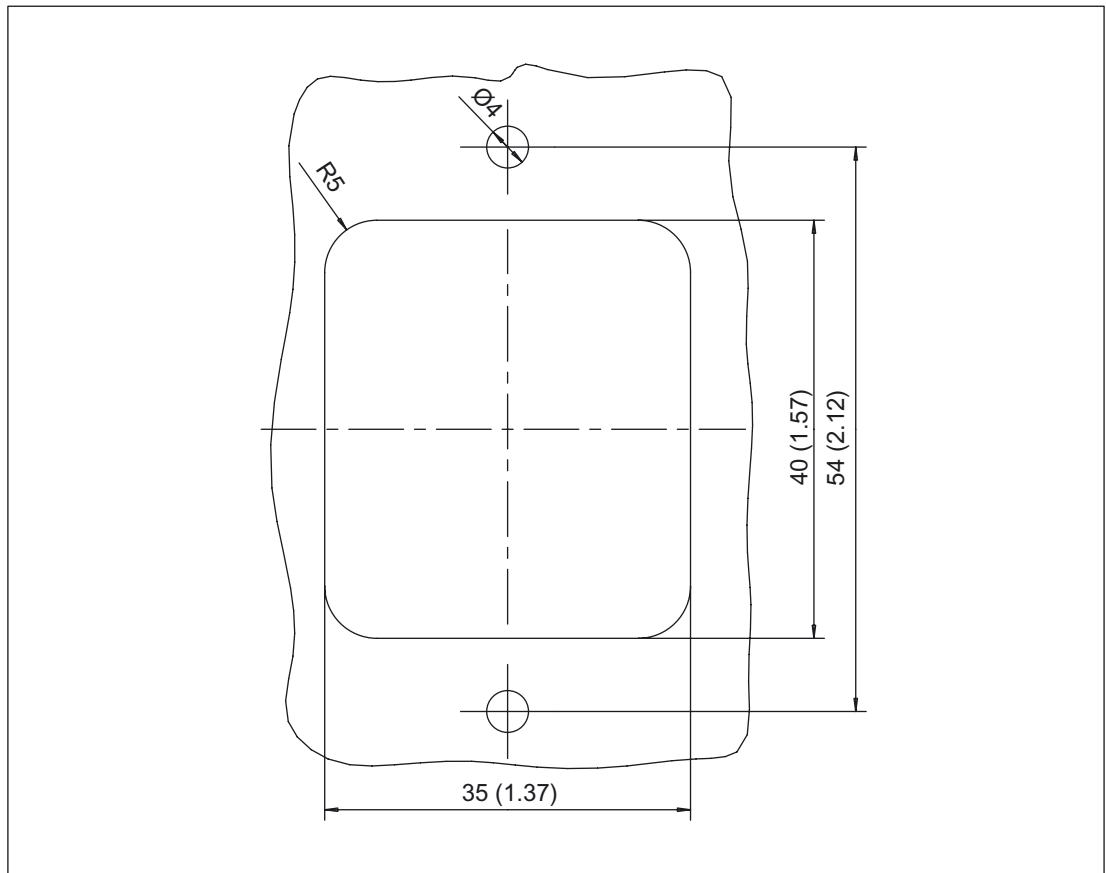

Figure 8-3 Cutout for cabinet

## 8.1.5 Mounting

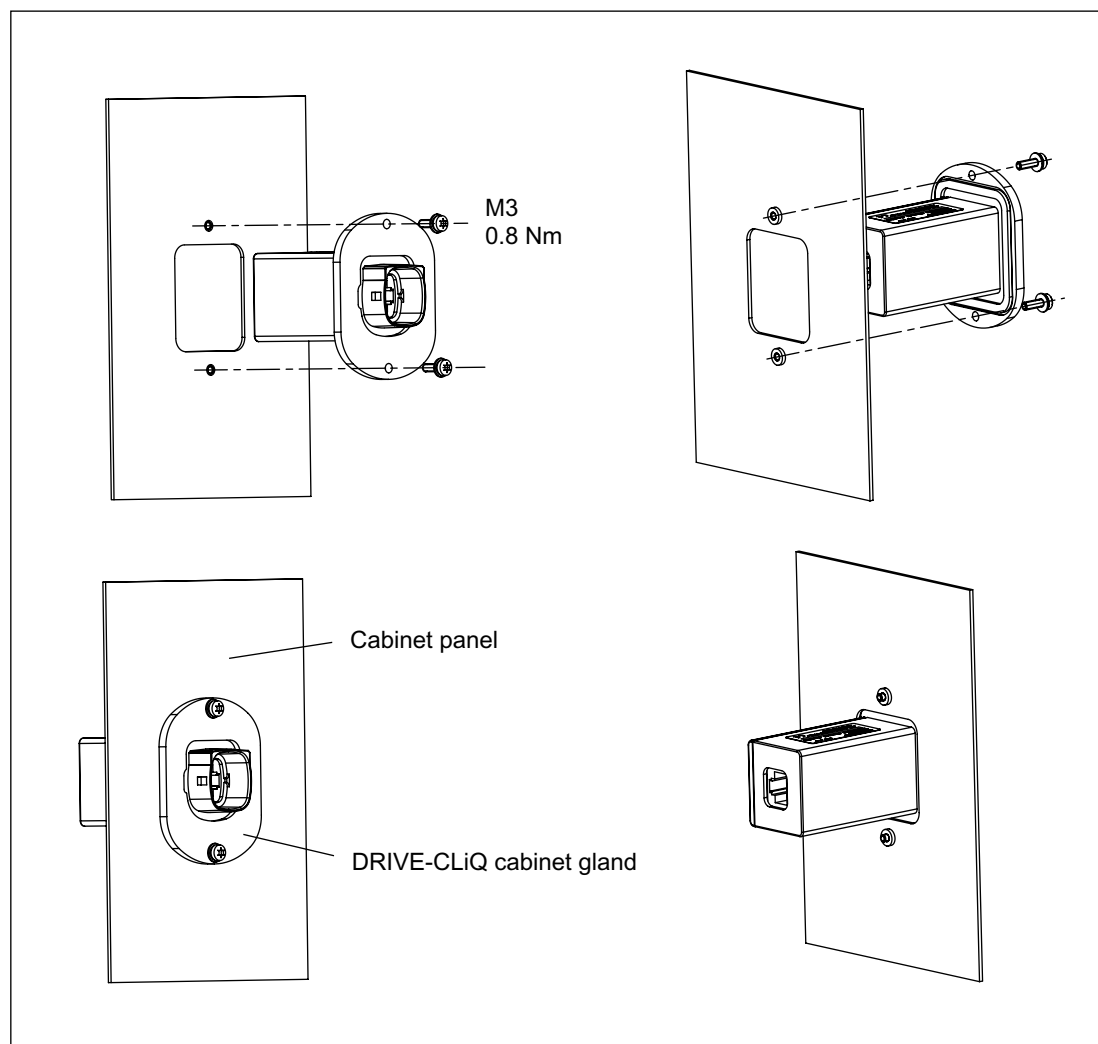

Figure 8-4 DRIVE-CLiQ cabinet gland

## Installation

1. Make an opening in the cabinet panel according to the Chapter "Dimension drawing" for the DRIVE-CLiQ cabinet gland.
2. Insert the components from the outer side of the cabinet through the opening in the cabinet.
3. Secure the DRIVE-CLiQ cabinet gland to the outer cabinet panel using two M3 screws and two nuts. In order to ensure good electromagnetic compatibility, a good electrical connection must be established between the DRIVE-CLiQ cabinet gland and the cabinet panel.

### 8.1.6 Technical data

Table 8-1 Technical data

DRIVE-CLiQ cabinet gland 6SL3066-2DA00-0AAx	Unit	
Weight	kg	0.135
Degree of protection	IP20 or IPXXB acc. to EN 60529 in the electrical cabinet IP54 to EN 60529 outside the electrical cabinet	

## 8.2 DRIVE-CLiQ coupling

### 8.2.1 Description

The DRIVE-CLiQ coupling is used to connect two DRIVE-CLiQ cables in accordance with degree of protection IP67 acc. to EN 60529.

In addition to the data lines, the power supply contacts of DRIVE-CLiQ are also routed via the coupling.

### 8.2.2 Safety Information

---

**Note**

Only Siemens cables should be used for DRIVE-CLiQ connections.

---



## 8.2.3 Interface description

### 8.2.3.1 Overview

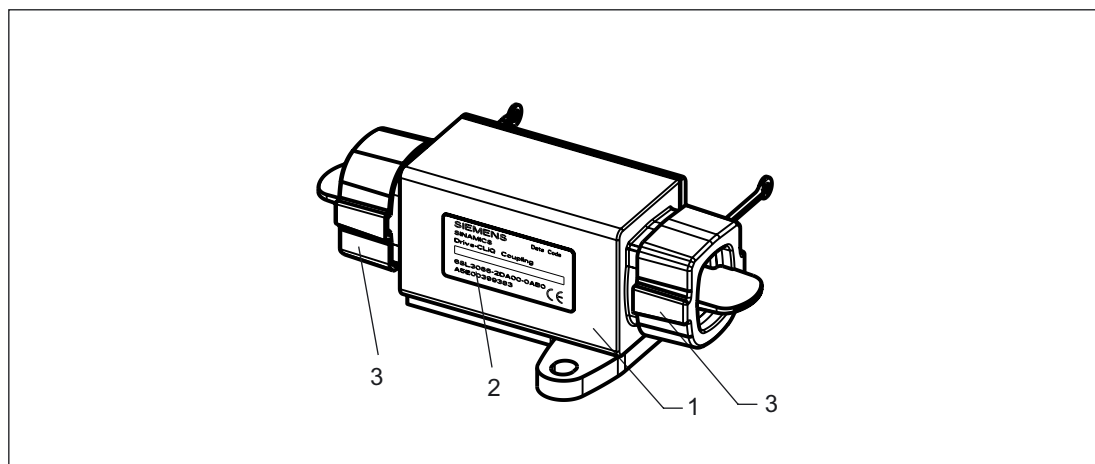

Figure 8-5 DRIVE-CLiQ coupling

1	DRIVE-CLiQ coupling
2	Type plate
3	Centering caps

8.2.4 Dimension drawing

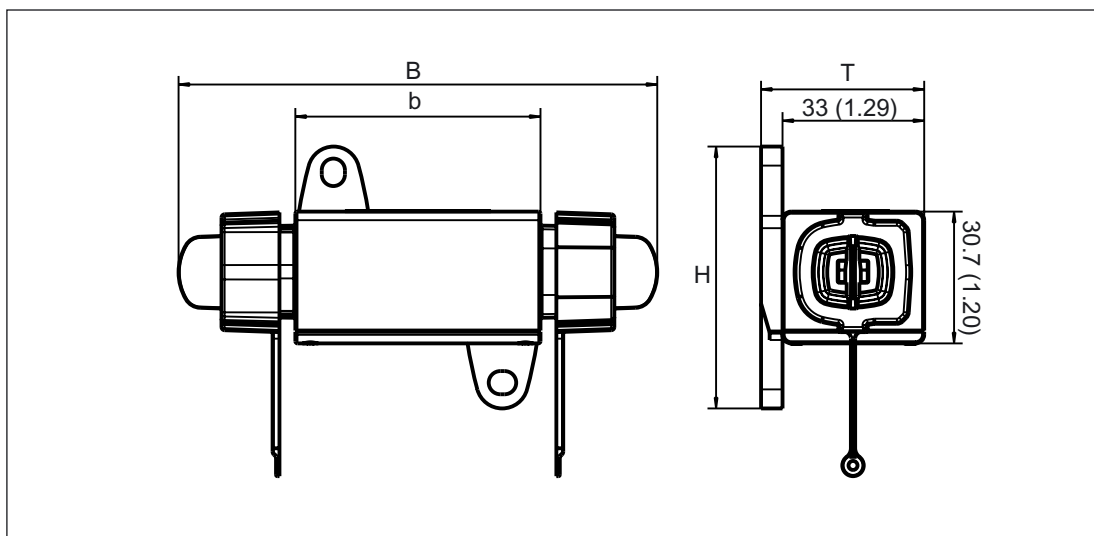

Figure 8-6 Dimension drawing, DRIVE-CLiQ coupling

Table 8-2 Dimensions of the DRIVE-CLiQ coupling, all data in mm and (inches)

Accessories	B [mm]	b [mm]	H [mm]	T [mm]
DRIVE-CLiQ coupling	111.5 (4.38)	57.1 (2.24)	61 (2.40)	38 (1.49)

## 8.2.5 Installation

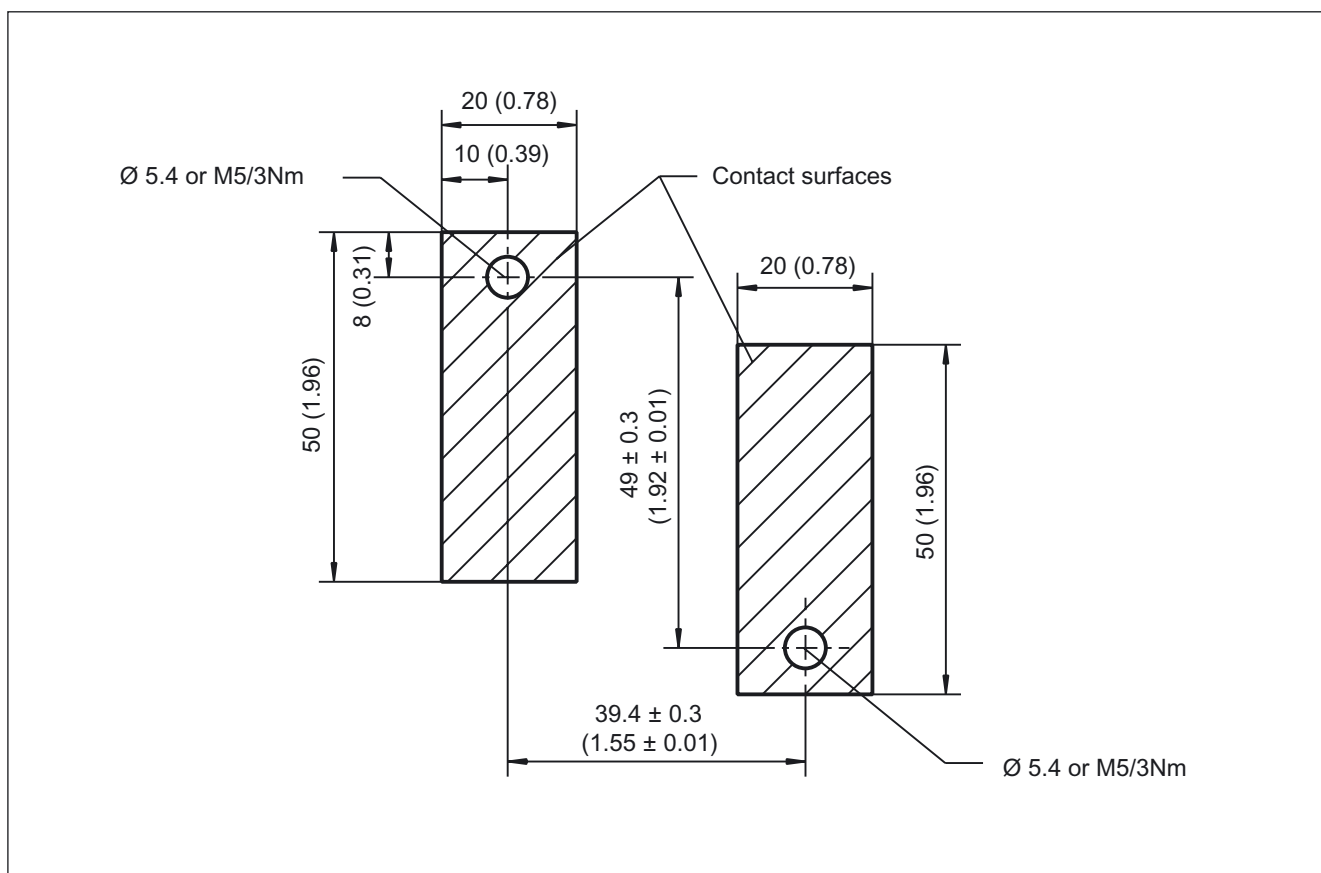

Figure 8-7 Hole drilling template for installation

1. Fit the DRIVE-CLiQ coupling to the mounting surface in accordance with the drilling template.
2. Remove the protective caps on the DRIVE-CLiQ coupling.
3. Insert the DRIVE-CLiQ connector at both ends of the DRIVE-CLiQ coupling.

## 8.2.6 Technical data

Table 8-3 Technical data

DRIVE-CLiQ coupling 6FX2003-0DC1x	Unit	
Weight	kg	0.14
Degree of protection	IP67 acc. to EN 60529	

## 8.3 Screening Kit

### Shielding methods

A Screening Kit is available as option for all frame sizes to connect the shield. This Screening Kit is used to connect the shield of power cables. For frame sizes A to C, the Screening Kit is directly mounted on the electrical cabinet panel and for frame sizes D to F, it is screwed to the Power Module.

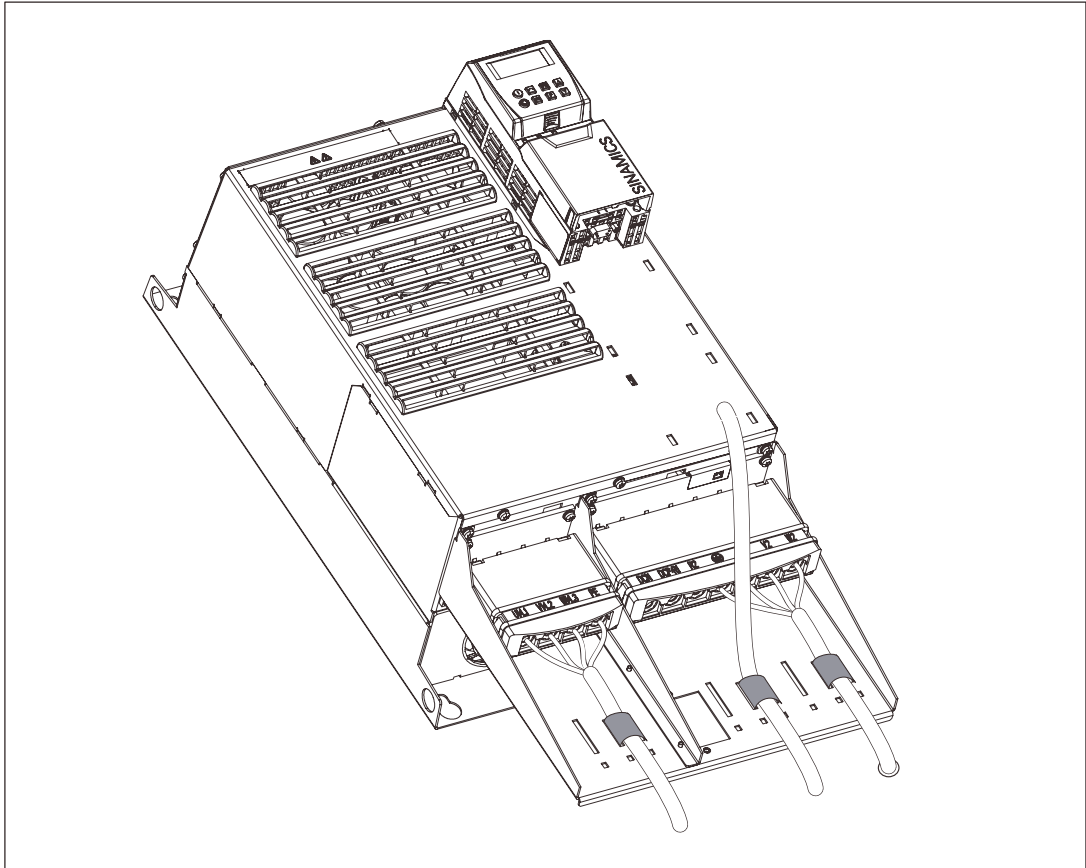

Figure 8-8 Power Module PM340 (frame sizes D, E) with CUA31 and Screening Kit

Table 8-4 Overview, Screening Kit, Part 1

<b>Screening Kit</b> 6SL3262-	1AA00-0BA0 with integrated line filter	1AB00-0DA0 without line filter/ with integrated line filter	1AC00-0DA0 without line filter/ with integrated line filter
<b>Suitable for Power Module</b> 6SL3210-	1SE11-3UA0 1SE11-7UA0 1SE12-2UA0 1SE13-1UA0 1SE14-1UA0	1SE16-0UA0 1SE17-7UA0 1SE21-0UA0	1SE21-8UA0 1SE22-5UA0 1SE23-2UA0
Frame size	A	B	C

Table 8-5 Overview, Screening Kit, Part 2

<b>Screening Kit</b> 6SL3262-	1AD00-0DA0 with integrated line filter	1AD00-0DA0 with integrated line filter	1AF00-0DA0 with integrated line filter
<b>Suitable for Power Module</b> 6SL3210-	1SE23-8UA0 1SE24-5UA0 1SE26-0UA0	1SE27-5UA0 1SE31-0UA0	1SE31-1UA0 1SE31-5UA0 1SE31-8UA0
Frame size	D	E	F

### 8.3.1 Dimension drawings

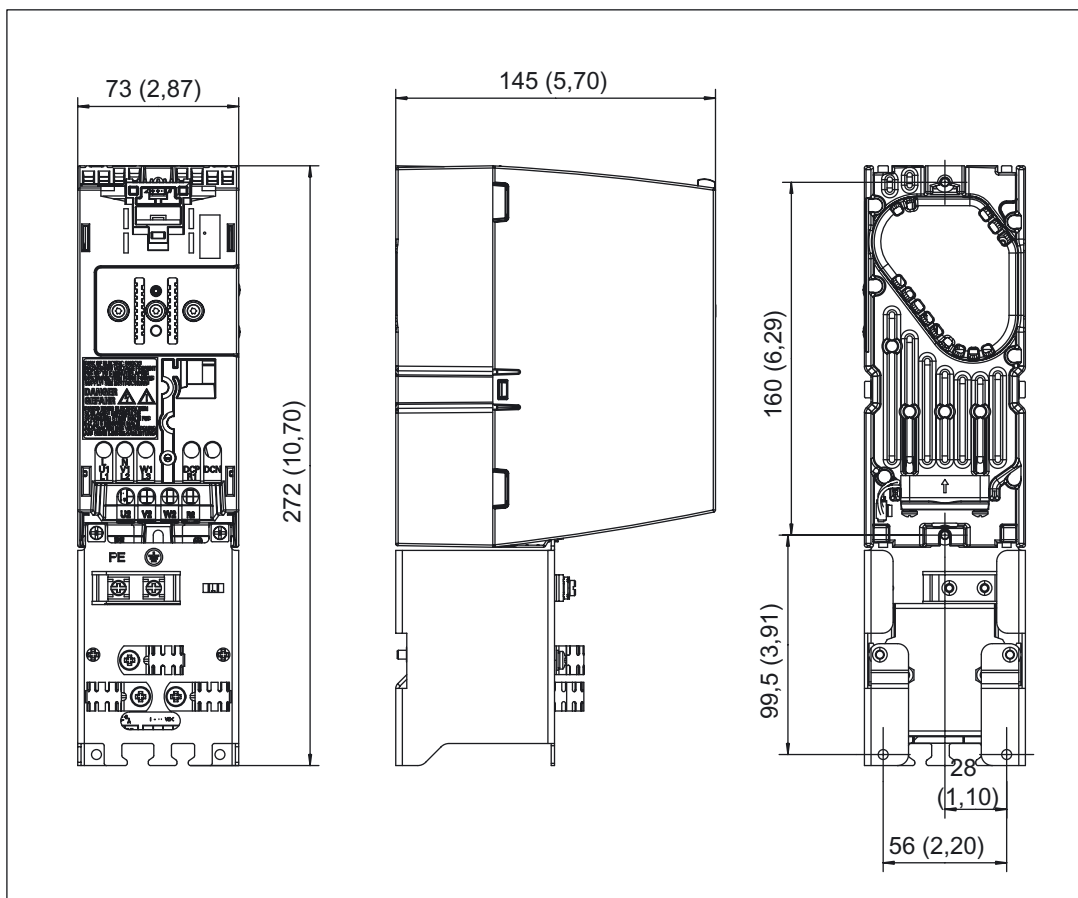

Figure 8-9 Dimension drawing: Power Module 340 with Screening Kit and Brake Relay, Size A



8.3 Screening Kit

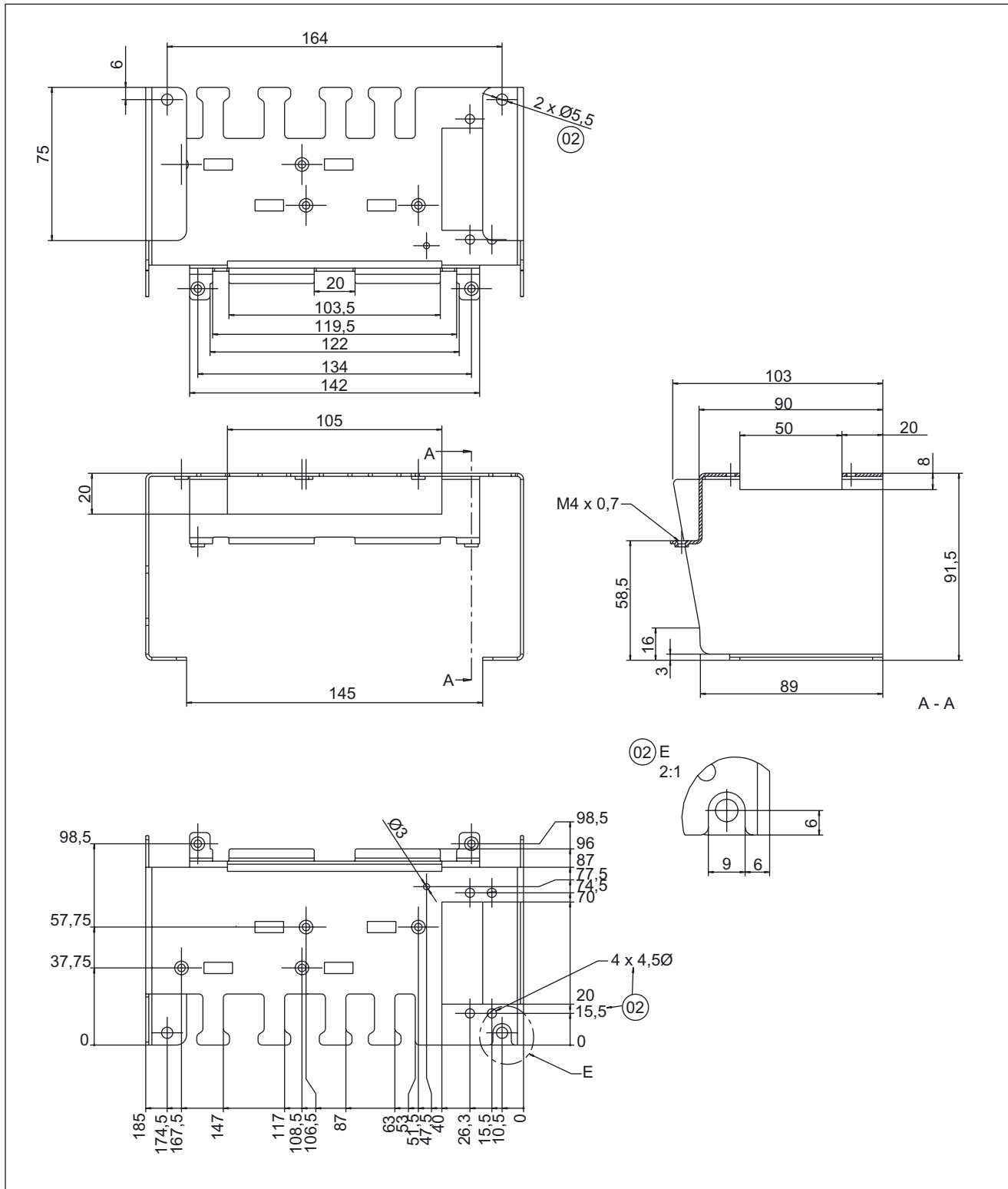

Figure 8-11 Dimension drawing: Screening Kit, size C



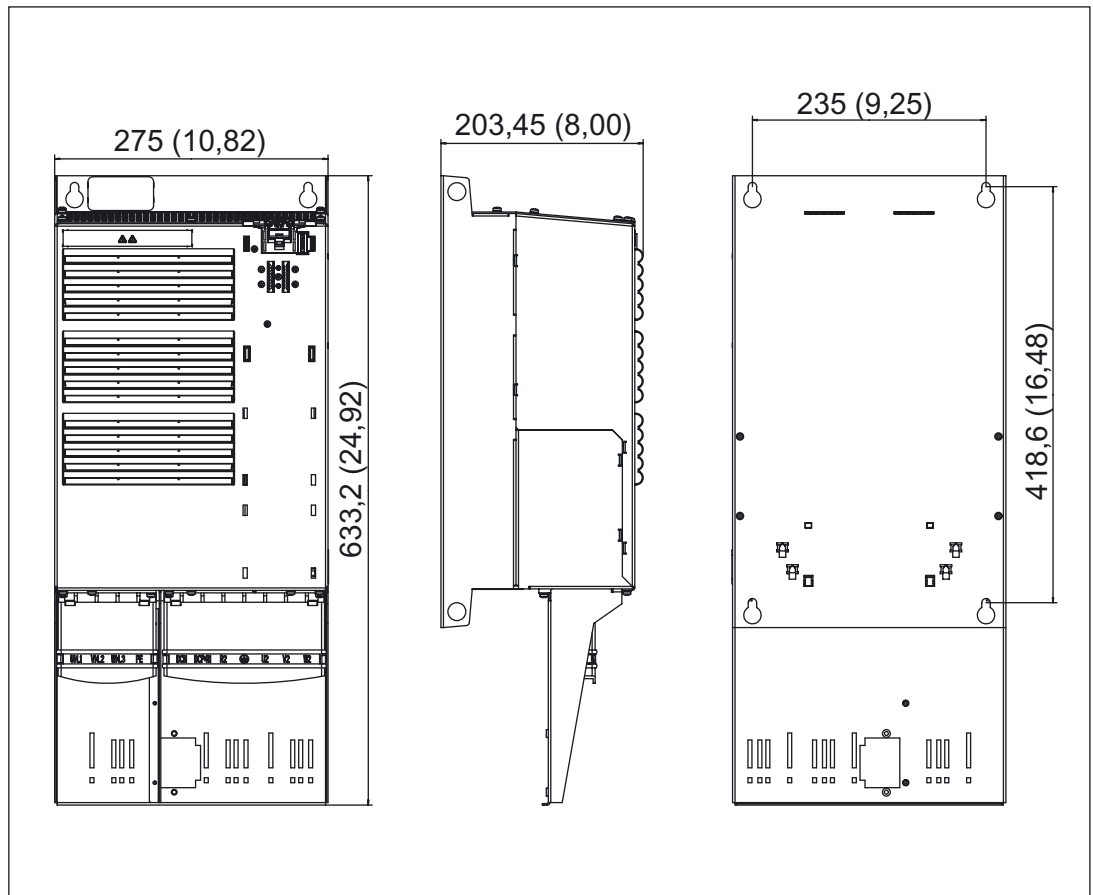

Figure 8-12 Dimension drawing: Power Module 340 with Screening Kit, size D

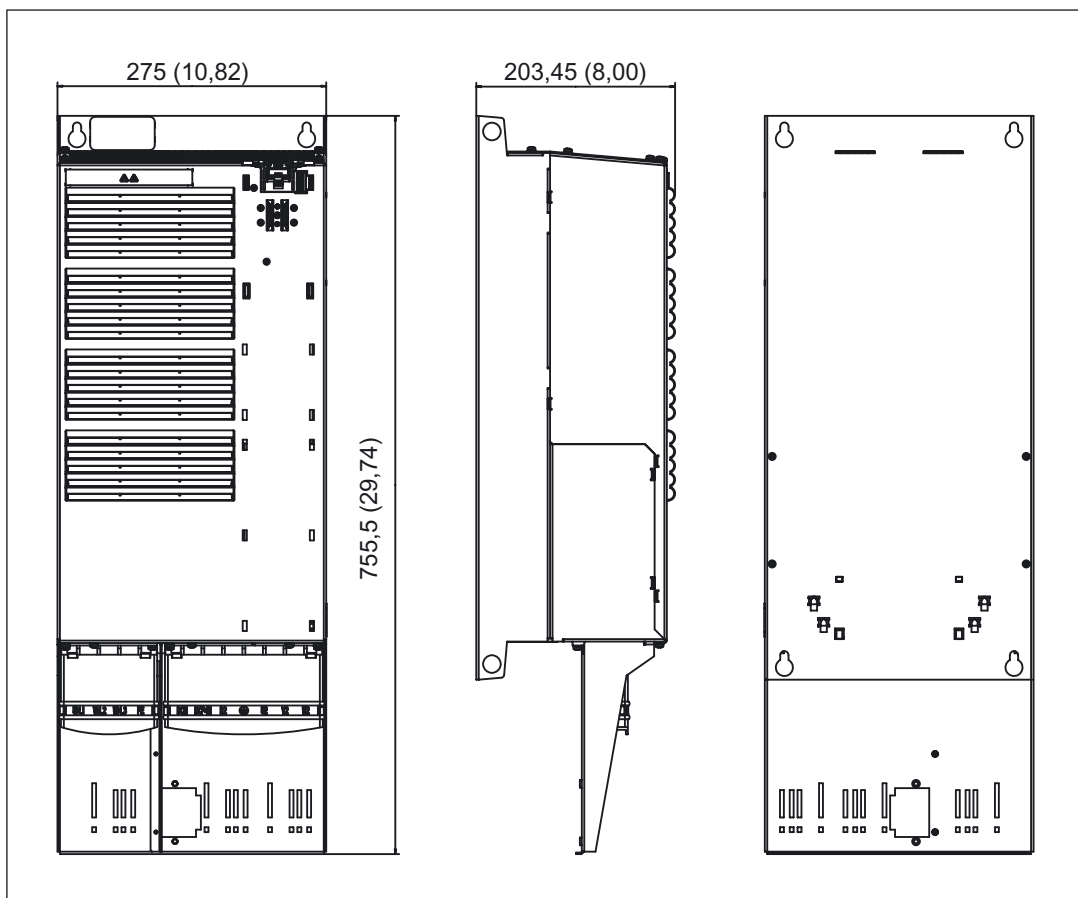

Figure 8-13 Dimension drawing: Power Module 340 with Screening Kit, size E

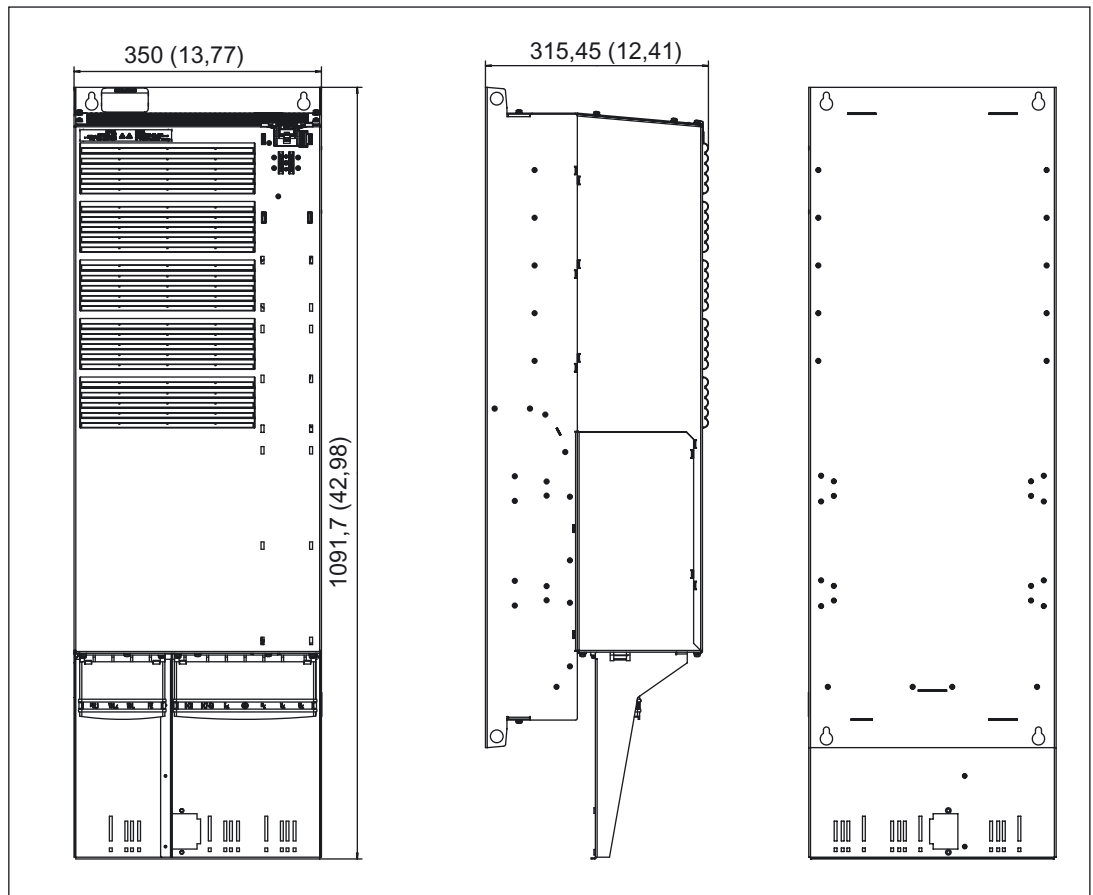

Figure 8-14 Dimension drawing: Power Module 340 with Screening Kit, size F

### 8.3.2 Mounting

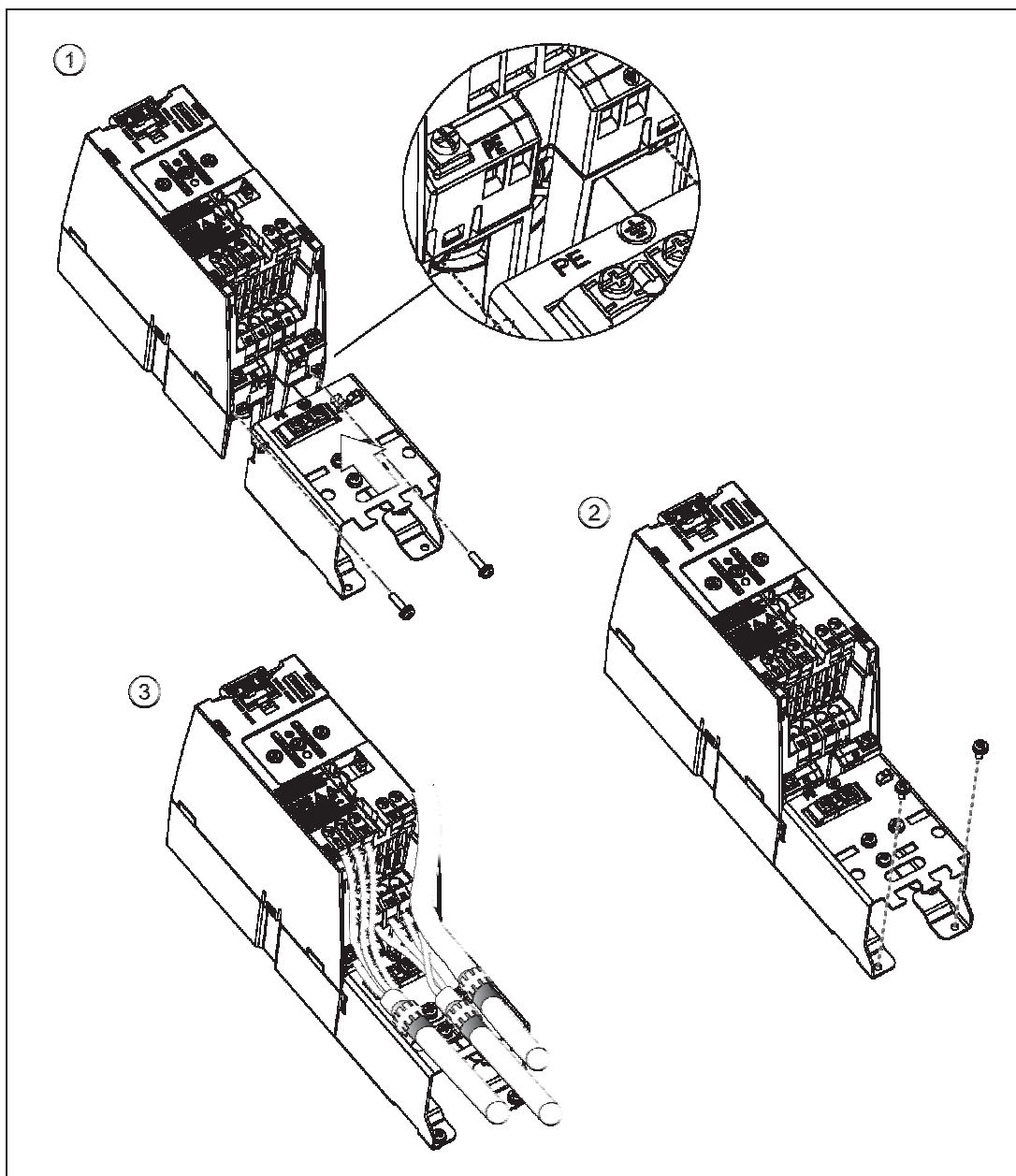

Figure 8-15 Mounting: Power Module PM340 and Screening Kit, size A

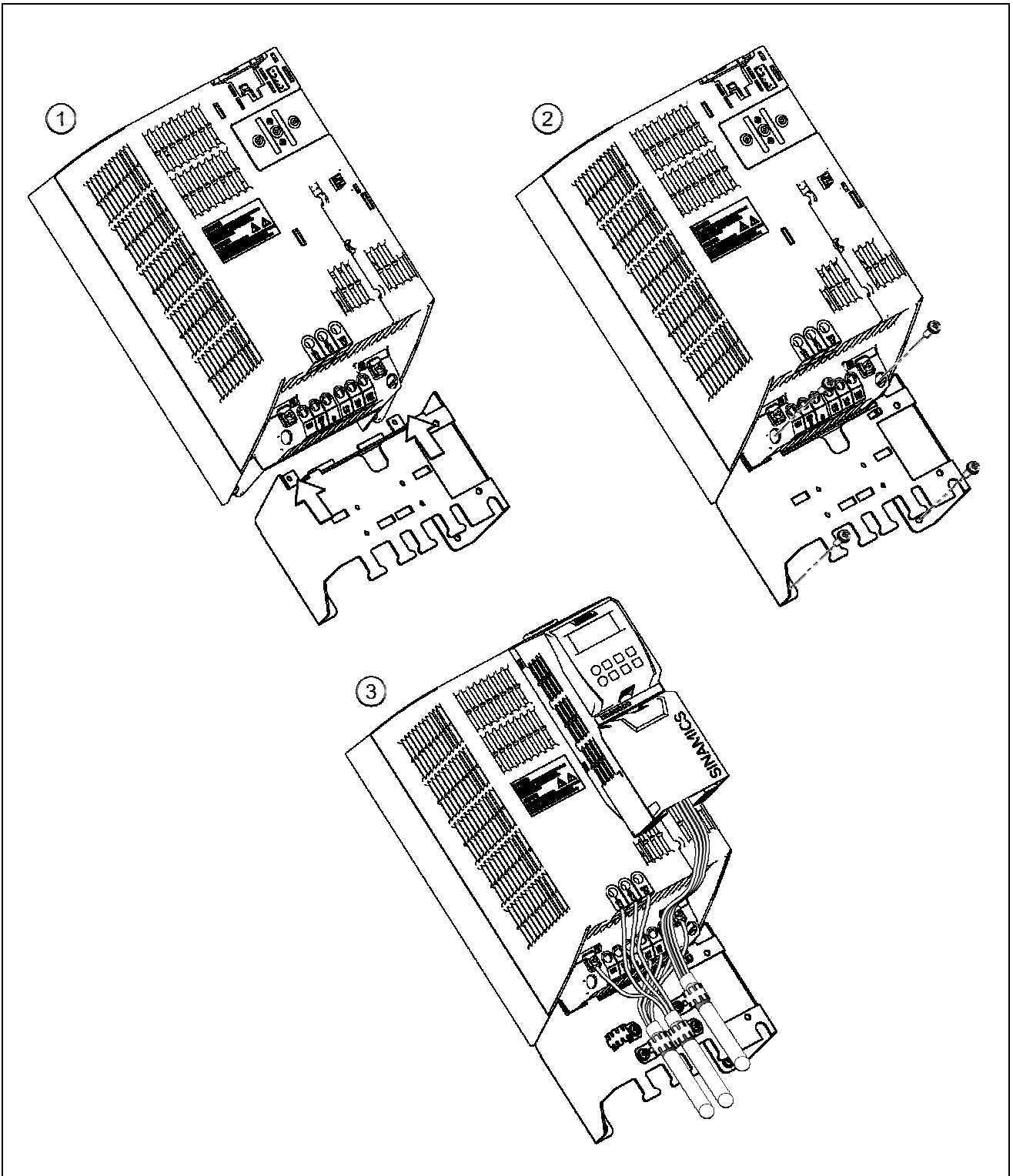

Figure 8-16 Mounting: Power Module PM340 and Screening Kit, sizes B and C

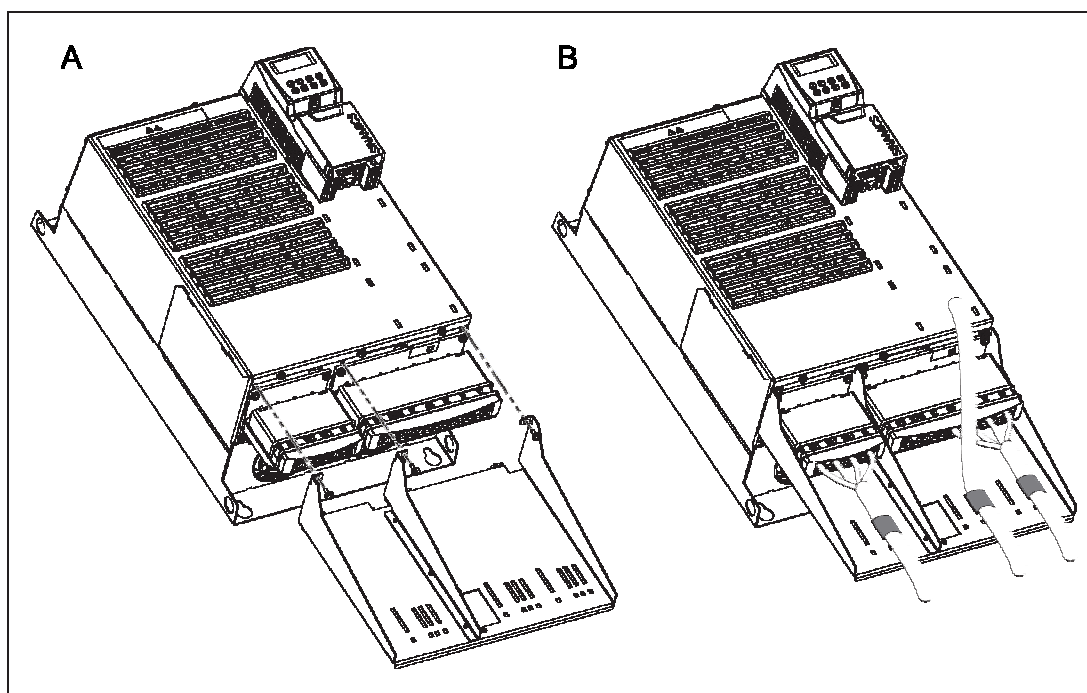

Figure 8-17 Mounting: Power Module PM340 and Screening Kit, sizes D and E

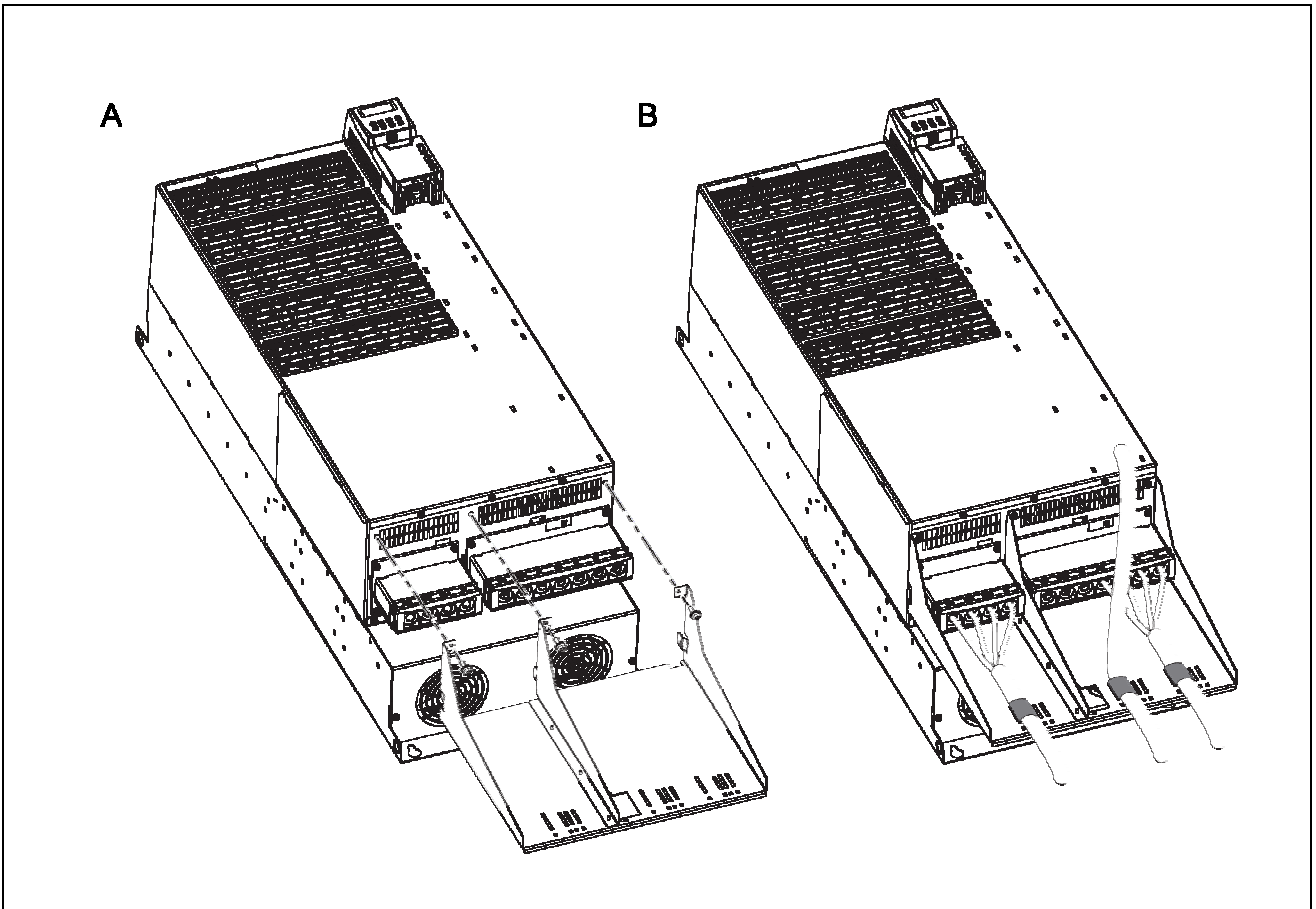

Figure 8-18 Mounting: Power Module PM340 and Screening Kit, size F





# Cabinet design and EMC for components, Blocksize format

# 9

## 9.1 Information

### 9.1.1 General

The SINAMICS S components are designed in accordance with degree of protection IP20 or IPXXB acc. to EN 60529 and as open-type devices to UL 50. This ensures protection against electric shocks. To ensure protection against mechanical stress and climatic conditions too, the components should only be operated in housing/cabinets/rooms that fulfill at least degree of protection IP54 and, as enclosure types, are designed to UL 50.

Prefabricated MOTION CONNECT cables are recommended.

#### **The Safety-Integrated safety function:**

The components must be protected against conducted contamination (e.g. by installing them in a cabinet with degree of protection IP54).

Provided that conducted interference can be prevented at the installation site, the degree of protection for the cabinet can be decreased accordingly.

### **Low-voltage switchgear and controlgear assemblies**

Part 1: Type-tested and partially type-tested low-voltage switchgear assemblies

If the SINAMICS S drive line-up is used for the electrical equipment of machines, the applicable requirements of EN 60204-1 must also be adhered to.

### Safety of machinery

Electrical equipment of machines

Part 1: General requirements

All information for device selection in this section applies to

- Operation in a TN system
- Operating voltage range 1-ph. 200 V AC to 3-ph. 440 V AC



#### Danger

If the shielding procedures described and the specified cable lengths are not observed, the machine may not operate properly.

---

### 9.1.2 Safety information

---

#### Note

When installing the equipment in cabinets, the ventilation slots must be covered to prevent drill swarf, wire end ferrules, and the like from falling into the housing.

Safety regulations governing shock protection must be observed. See also EN 60204-1.

---

#### Caution

To ensure that the encoder system works properly, you are advised to use the original Siemens accessories from catalogs D21.1 and D21.2.

Only motors with a safe electrically isolated holding brake may be connected. The brake conductors must also be safely electrically isolated.

If the motor power cable is connected to intermediate terminals, the power cables and brake cables must be routed apart ( $\geq 300$  mm).

After an intermediate terminal (e.g. due to a terminal block), it is best to continue routing using the approved MOTION-CONNECT cable.

---



#### Warning

Cable shields and unused conductors of power cables (e.g. brake conductors) must be connected to PE potential.

Non-observance can cause lethal shock voltages.

---

## 9.2 Selection of Devices Required for Operating SINAMICS

### 9.2.1 General

The following components are required to be connected to the line supply:

- Line disconnecting device
- Line fuse
- Line contactor (this is required for electrical isolation)
- Line filter (optional for Power Module PM340, frame size A)
- Line reactor (refer to Chapter Line supply connection)

### 9.2.2 Information about line disconnecting devices

The line disconnecting device for the electrical equipment may be used for correct isolation of the drive line-up from the power supply. This line disconnecting device must be designed for the electrical equipment of machines in accordance with the requirements of EN 60204-1, Section 5.3. The relevant technical specifications must be taken into consideration for the purpose of selecting the device. Other consumers of the electrical equipment must also be taken into consideration when the device is selected.

The line disconnecting device must be equipped with a leading auxiliary switch ( $t \geq 10$  ms). This must be integrated in the shutdown path of the Power Modules (EP terminals).

The accessories required for the line disconnecting device must be selected from the manufacturer catalogs. See also catalog D21.2.

### 9.2.3 Overcurrent protection using line fuses or circuit-breakers

The cables for the drive line-up power supply must be protected against overcurrents. NH, D, and DO-type fuses with a gL characteristic or suitable circuit-breakers can be used for this purpose.

---

#### Note

The devices can be connected to line supplies up to 480 V<sub>AC</sub>, which can supply a maximum of 36 kA symmetrical ("uninfluenced current" acc. to EN 60269-1).

---

For further information: Refer to Catalog D21.2.

## 9.2.4 Line Contactors

Line contactors are required to provide electrical isolation between the drive line-up and the line supply.

When selecting a line contactor, the characteristic values in the technical data apply. The cable routing, the bundling factor and the factor for the ambient temperature according to EN 60204-1 must be taken into account when dimensioning the various cables.



### **Caution**

Line contactors must not be switched under load.

---

When the digital output is used to control the line contactor, its making/breaking capacity must be taken into account.

## 9.3 24 V DC Supply Voltage

### 9.3.1 General

The 24 V DC voltage is required for the power supply of:

1. The load voltage of the Control Unit digital outputs.  
The Control Units are supplied with power via the PM-IF. 24 V must also be connected in the following cases:
  - Commissioning / diagnostics when the Power Module power supply voltage is switched-out.
  - Using the digital outputs CU310
2. The electronics of the Sensor Module
3. The Safe Brake Relay (motor holding brake)

Other loads can be connected to these power supply units if they are separately protected from overcurrent.

---

#### **Notice**

If other consumers are connected to the power supply, connected inductance devices (contactors, relays) must be fitted with suitable overvoltage protection circuits.

---

---

#### **Notice**

A regulated DC power supply is required to operate motors with a built-in holding brake. The power is supplied via the 24 V connection (Safe Brake Relay). The voltage tolerances of the motor holding brakes and the voltage drops of the connection cables must be taken into account.

The DC power supply should be set to 26 V. This ensures that the voltage supply for the brake remains within the permissible range when the following conditions are fulfilled:

- Using Siemens three-phase motors
- Using Siemens MOTION-CONNECT power cables

Motor cable lengths: max. 100 m

---

### 9.3.2 Selecting power supply units

You are advised to use the devices in the following table. These devices meet the applicable requirements of EN 60204-1.

Table 9-1 Recommended SITOP Power

Rated output current [A]	Input voltage range [V]	Short-circuit current [A]	Order No.
5	2AC 85-132/170 – 550	5.5	6EP1333-3BA00
10	2AC 85-132/176 – 550	30 for 25 ms	6EP1334-3BA00
20	3AC 320 – 550	23	6EP1336-3BA00
40	3AC 320 – 550	46	6EP1337-3BA00

Table 9-2 Recommendation for Control Supply Module

Rated output current [A]	Input voltage range [V]	Short-circuit current [A]	Order No.
20	3-ph. 380 V AC -10% (-15% < 1 min) to 3-ph. 480 V AC +10% DC 300 – 800	< 24	6SL3100-1DE22-0AA0

See catalog D21.2.



#### Warning

When an external power supply is used (e.g. SITOP), the ground potential must be connected to the protective conductor system (PELV).

### 9.3.3 24 V component current consumption

A separate 24 V power supply must be used for the SINAMICS S120 drive line-up.

The following table can be used to calculate the 24 V DC power supply. The values for typical current consumption are used as a basis for configuration.

Table 9-3 Overview of 24 V DC current consumption

<b>Component</b>	<b>Typical current consumption [A<sub>DC</sub>]</b>
CU320	0.8
CU310 DP for each digital output	0.8
CU310 PN for each digital output	0.8
CUA31 for each digital output	0.15
DRIVE-CLiQ (e.g. motors with DRIVE-CLiQ interface)	Typ. 0.25, max. 0.45
Brake (e.g. motor holding brake)	Typ. 0.4 to 1.1; max. 2
Sensor Module Cabinet	
SMC10	0.2
SMC20	0.2
Sensor Module External	
SME20	0.11
SME25	0.11
SME120	0.16
SME125	0.16

### 9.3.4 Overcurrent Protection

Cables on both the primary and the secondary side of the power supply unit must be protected from overcurrent. Primary side protection must be implemented according to the manufacturer's instructions. Secondary side protection must be rated to deal with the actual conditions. In particular:

- Loading due to loads, possibly the simultaneity factor in response to machine operation
- Current carrying capacity of the conductors used and cables in normal and short-circuit conditions
- Ambient temperature
- Cable bundling (e.g. laying in a common duct)
- Cable laying method to EN 60204-1

EN 60204-1, Section 14, can be used to determine the overcurrent protection devices.

Circuit-breakers from the Siemens NSK catalog are recommended as overcurrent protection devices on the primary side, and miniature circuit-breakers or SITOP select 6EP1961-2BA00 as overcurrent protection devices on the secondary side. The MCBs can be selected according to Siemens catalog "BETA Modular Installation Devices - ET B1".

Miniature circuit-breakers are recommended as overcurrent protective device for cables and busbars. The ground potential M must be connected to the protective conductor system (PELV).

When selecting the circuit-breaker, the following standards must be carefully observed:

EN 61800-5-1, EN 60204-1, IEC 60364-5-52, IEC 60287-1 to -3, EN 60228 and UL 508C.

In so doing, the following conditions for the conductors/cables must be carefully taken into consideration:

- Ambient temperature 55 °C
- Limiting conductor temperature  $\geq 75$  °C for operation with the rated load current
- Cable length max.:
  - 10 m for the supply cables
  - 30 m for signal lines

In addition, the conductors/cables should be routed so that

- Max. 1 conductor pair is bundled, and
- The 24 V conductors/cables must be routed separately from other cables and conductors that can conduct operating currents.



Table 9-4 MCBs by conductor cross-section and temperature

Conductor cross-section	Max. value up to 40 °C	Max. value up to 55°C
1.5 mm <sup>2</sup>	10 A	6 A
2.5 mm <sup>2</sup>	16 A	10 A
4 mm <sup>2</sup>	25 A	16 A
6 mm <sup>2</sup>	32 A	20 A

The trip characteristic of the MCBs must be selected to match the loads to be protected and the max. current provided by the power supply unit in the event of a short-circuit.

## 9.4 Arrangement of components and equipment

### 9.4.1 General

The arrangement of the components and equipment takes account of

- Space requirements
- Cable routing
- Bending radius of connection cables  
For MOTION-CONNECT cables, see catalog D21.1 or D21.2.
- Heat dissipation
- EMC

Components are usually located centrally in a cabinet.

The mounting clearances necessary above and below the components can, under certain circumstances, exceed the minimum clearances specified in the product documentation.

### 9.4.2 Mounting

The components should be mounted on a conductive mounting surface to ensure low impedance between the component and the mounting surface. Mounting plates with a galvanized surface are suitable.



Figure 9-1 Mounting the CU310 onto the Power Module 340 (frame size D)

### Wiring rules for DRIVE-CLiQ

Refer to /IH1/ SINAMICS Commissioning Manual.

## 9.5 Information about Electromagnetic Compatibility (EMC) and Cable Routing

### 9.5.1 General

Requirements to implement EMC are listed in EN 61000-6-2, EN 61000-6-4, EN 61800-3, EN 60204-1 and in the EMC Design Directives - Order No. 6FC5297-□AD30-0AP□.

Conformance with the EMC Directive of the EC can be secured by following the measures described in the EMC Design Directives.

When mounting components in cabinets, in order to fulfill the EMC directive, the following conditions must be additionally observed:

- Connected to TN line supply systems with grounded neutral point
- SINAMICS line filter (optional for frame size A)
- Observance of information about cable shielding and equipotential bonding
- Only the recommended Siemens power and signal cables are used
- Only cables from Siemens must be used for DRIVE-CLiQ connections.

For MOTION-CONNECT cables refer to catalog D21.1 or D21.2

---

#### Caution

If couplings or cabinet glands are required for the DRIVE-CLiQ connections, then only the DRIVE-CLiQ coupling and DRIVE-CLiQ cabinet gland, described in the Chapter Accessories, may be used.

---



---

#### Danger

If the shielding procedures described and the specified cable lengths are not observed, the machine may not operate properly.

---

## **9.5.2 Cable Shielding and Routing**

In order to comply with the EMC requirements, certain cables must be routed apart from other cables and from certain components. To full EMC requirements, the following cables must be used with shields:

- Power supply cables from line filter via line reactor to Power Module
- All motor cables (if necessary, including cables for motor holding brake)
- Cables for "fast inputs" of the Control Unit
- Cables for analog direct voltage/current signals
- Signal cables for sensors
- Cables for temperature sensors

Alternative measures (e.g. routing behind mounting plates, suitable clearances) can also be used provided they have similar results. This excludes measures that relate to the design, installation, and routing of motor power cables and signal cables. If unshielded cables are used between the line connection point and line filter, make sure that no interfering cables are routed in parallel.

The cable shields must be connected as close to the conductor terminal connections as possible to ensure a low-impedance connection with cabinet ground.

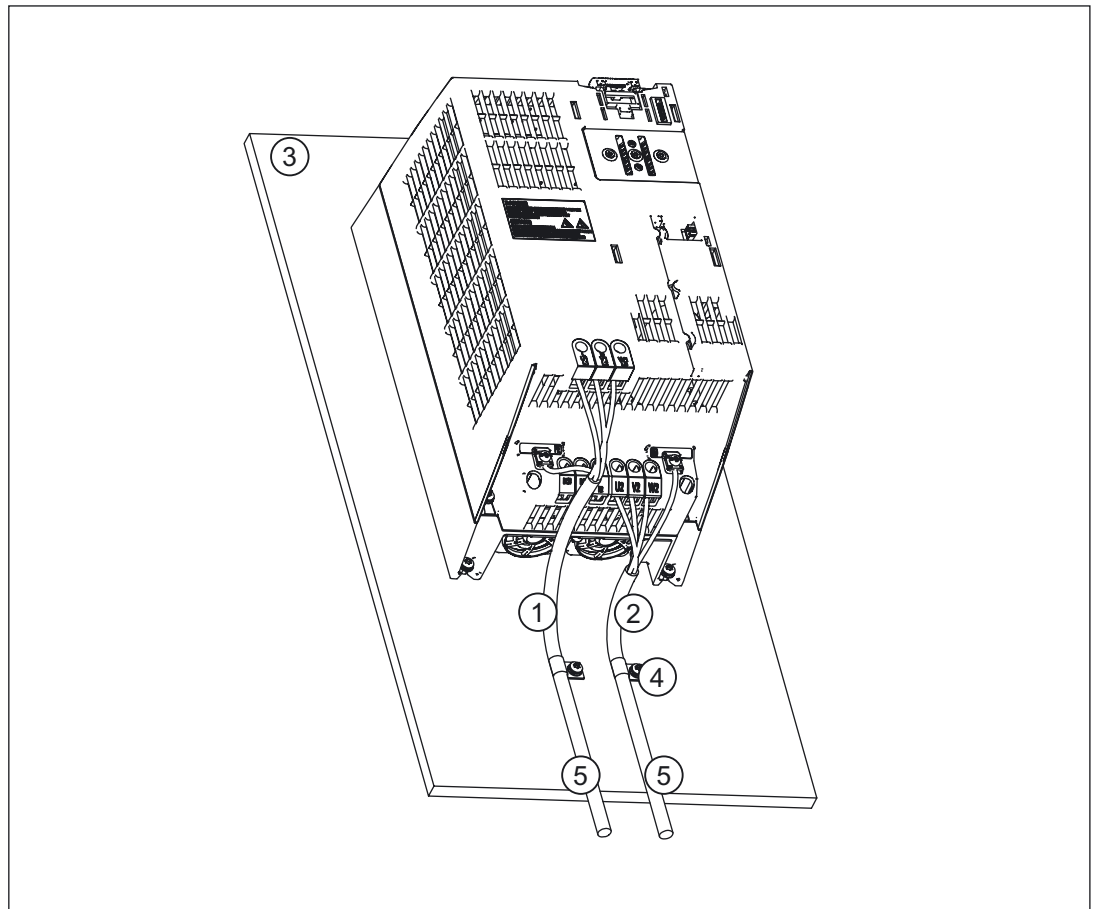

Figure 9-2 Shielding of a Power Module PM340

1. Line supply input
2. Motor cable
3. Rear metal panel
4. Use suitable clamps/clips to reliably connect the shield of the motor and field cable to the rear metal panel.
5. Shielded cable

Alternatively, the cable shields can be connected to them metal mounting plate using pipe clamps and serrated rails. The cable length between the shield contact point and the terminals for cable conductors must be kept as short as possible.

Shield connection plates with pre-prepared clip contacts are available for connecting the shields for power cables of Power Modules.

All cables inside the cabinet must be connected as closely as possible to parts connected with cabinet ground, such as a mounting plate or cabinet wall. Ducts made of sheet steel or routing cables between between steel sheets (e.g. between the mounting plate and back wall) should provide adequate shielding.

Avoid, where possible, routing unshielded cables, connected to the drive line-up, in the immediate vicinity of noise sources, e.g. transformers. Signal lines (shielded and unshielded) connected to the drive line-up, must be routed as far as possible away from strong external magnetic fields (e.g. transformers, line reactors). In both cases, a distance of  $\geq 300$  mm is usually sufficient.

### Signal and DC power supply cables

Operating unshielded signal and direct current supply cables (e.g. 24 V infeed with external supply):

- Direct current supply cables: Max. permissible length: 10 m
- Unshielded signal cables: Max. permissible length: 30 m (without additional wiring)

For greater lengths, suitable wiring must be connected by the user to provide overvoltage protection. For example:

Table 9-5 Recommendations for overvoltage protection

DC supply	24 V signal cables
Weidmüller Type no.: PU DS 24V 16A	Weidmüller Type no.: MCZ OVP TAZ
Weidmüller GmbH & Co. KG An der Talle 89 33102 Paderborn Tel. 05252/960-0 Fax 05252/960-116 <a href="http://www.weidmueller.com">www.weidmueller.com</a>	

---

#### Caution

The connected signal and power cables must not cover the ventilation slots.

---

---

#### Caution

Unshielded signal cables must not be routed parallel to power cables.

---

### 9.5.3 Equipotential bonding

The SINAMICS S drive system is designed for use in cabinets with a PE conductor connection.

If the drive line-up is arranged on a common unpainted metal-surfaced mounting plate, e.g. with a galvanized surface, no additional equipotential bonding is needed within the drive line-up as

- All parts of the switchgear assembly are connected to the protective conductor system.
- The mounting plate is connected with the external PE conductor by means of a finely-stranded copper conductor with a cross-section of 16 mm<sup>2</sup>, including the outer conductor. From a cross-section of 25 mm<sup>2</sup> copper, the outer cross-section of the finely-stranded conductor is halved.

For other installation methods, equipotential bonding must be implemented using conductor cross-sections as stated in the second item in the list or at least equal to the conductance.

If components are mounted on DIN rails, the data listed in the second item applies for equipotential bonding. If only smaller connection cross-sections are permissible on components, the largest must be used (e.g. 6 mm<sup>2</sup> for TM31 and SMC). These requirements also apply to distributed components located outside the cabinet.

For a PROFIBUS connection between two cabinets, a finely stranded potential bonding connector should be used with a cross-section of 4 mm<sup>2</sup>. This conductor must be routed alongside the PROFIBUS cable.

## 9.6 Connection Methods

### 9.6.1 Screw terminals

#### Connectable conductor cross-sections of screw terminals

Table 9-6 Screw terminals

Screw terminal type			
1	Connectable conductor cross-sections	Flexible With wire end ferrule, without plastic sleeve With wire end ferrule, with plastic sleeve	0.14 mm <sup>2</sup> to 1.5 mm <sup>2</sup> 0.25 mm <sup>2</sup> to 1.5 mm <sup>2</sup> 0.25 mm <sup>2</sup> to 0.5 mm <sup>2</sup>
	Insulation stripping length	7 mm	
	Tool	Screwdriver 0.4 x 2.0 mm	
	Tightening torque	0.22 to 0.25 Nm	
2	Connectable conductor cross-sections	Flexible With wire end ferrule, without plastic sleeve With wire end ferrule, with plastic sleeve	0.2 mm <sup>2</sup> to 2.5 mm <sup>2</sup> 0.25 mm <sup>2</sup> to 1 mm <sup>2</sup> 0.5 mm <sup>2</sup> to 1 mm <sup>2</sup>
	Insulation stripping length	7 mm	
	Tool	Screwdriver 0.6 x 3.5 mm	
	Tightening torque	0.5 to 0.6 Nm	



## 9.7 Information on cabinet cooling

### 9.7.1 General

Electrical cabinets can be cooled, using among other things the following:

- filtered fans
- heat exchangers or
- cooling units.

The decision in favor of one of these methods will depend on the prevailing ambient conditions and the cooling power required.

The air routing within the electrical cabinet and the cooling clearances specified here must be observed. No other components or cables must be located in these areas.

---

#### Caution

If you do not observe the guidelines for installing SINAMICS equipment in the cabinet, this can reduce the service life of the equipment and result in premature component failure.

---

You must take into account the following specifications when mounting/installing SINAMICS components:

- Cooling clearance
- Cable routing
- Air guidance, air-conditioner

Table 9-7 Cooling clearances around the components

Component	Clearance above and below in mm and (inches)	Lateral clearance in mm and (inches)
CU310 DP	50 (1.97)	0
CU310 PN	50 (1.97)	0
CUA31	50 (1.97)	0
SMCxx	50 (1.97)	0
Line filters	100 (3.93)	
Line reactors	100 (3.93)	0
PM340, Blocksize, frame size A	100 (3.93)	30 (1.18)
PM340, Blocksize, frame size B	100 (3.93)	40 (1.57)
PM340, Blocksize, frame size C	125 (4.92)	50 (1.97)
PM340 Blocksize, frame sizes D and E	300 (11.81)	0
PM340, Blocksize, frame size F	350 (13.77)	0

9.7 Information on cabinet cooling

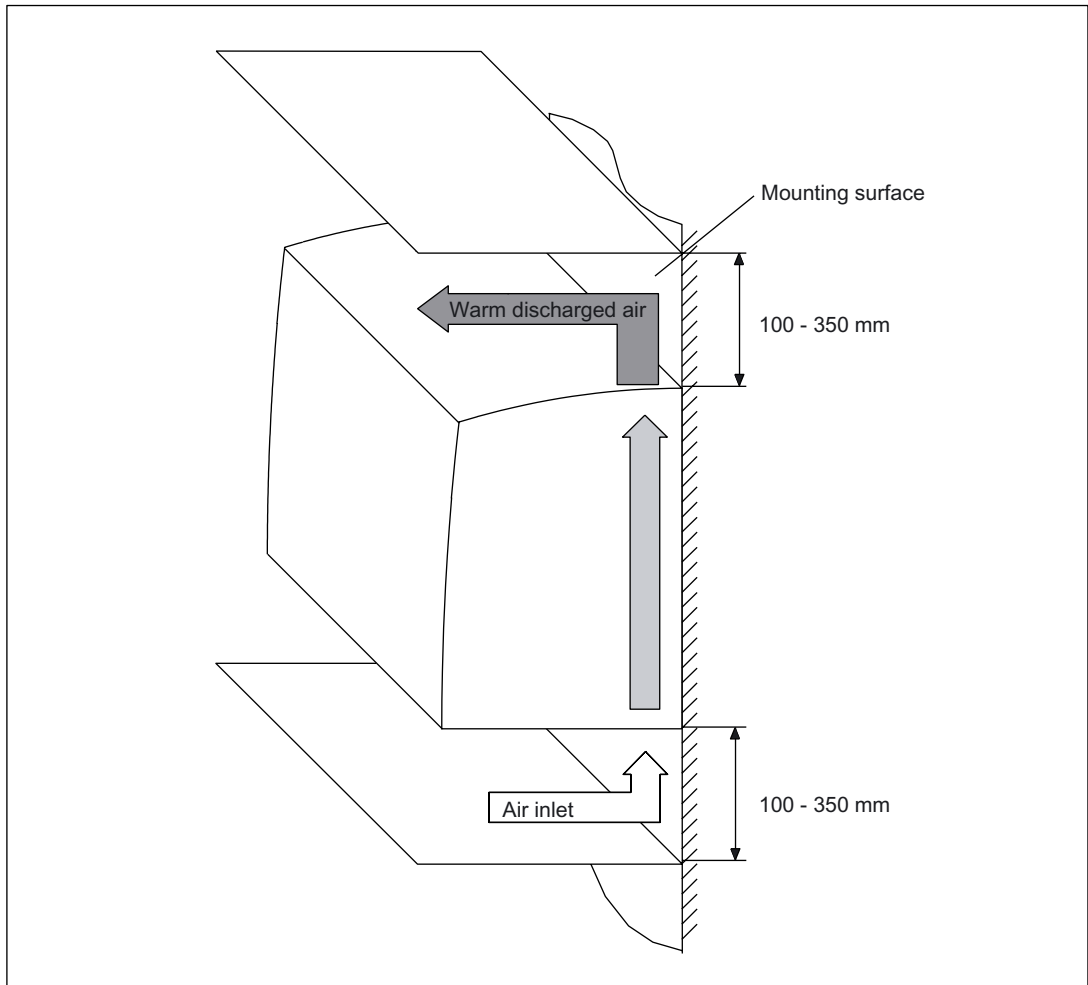

Figure 9-3 Cooling clearances

## 9.7.2 Ventilation

The SINAMICS equipment is ventilated separately by means of integrated fans and is in some cases cooled by means of natural convection.

The cooling air must flow through the components vertically from bottom (cooler region) to top (region heated by operation).

If filtered fans, heat exchangers, or air conditioners are used, you must ensure that the air is flowing in the right direction. You must also ensure that the warm air can escape at the top. A cooling clearance of at least 80 mm above and below must be observed.

---

### **Note**

Cables must not be routed on the components; the ventilation meshes must not be covered. Cold air must not be allowed to blow directly onto electronic equipment.

---

---

### **Note**

The distance between the blow-out aperture of the air conditioner and the electronic equipment must be at least 200 mm.

---

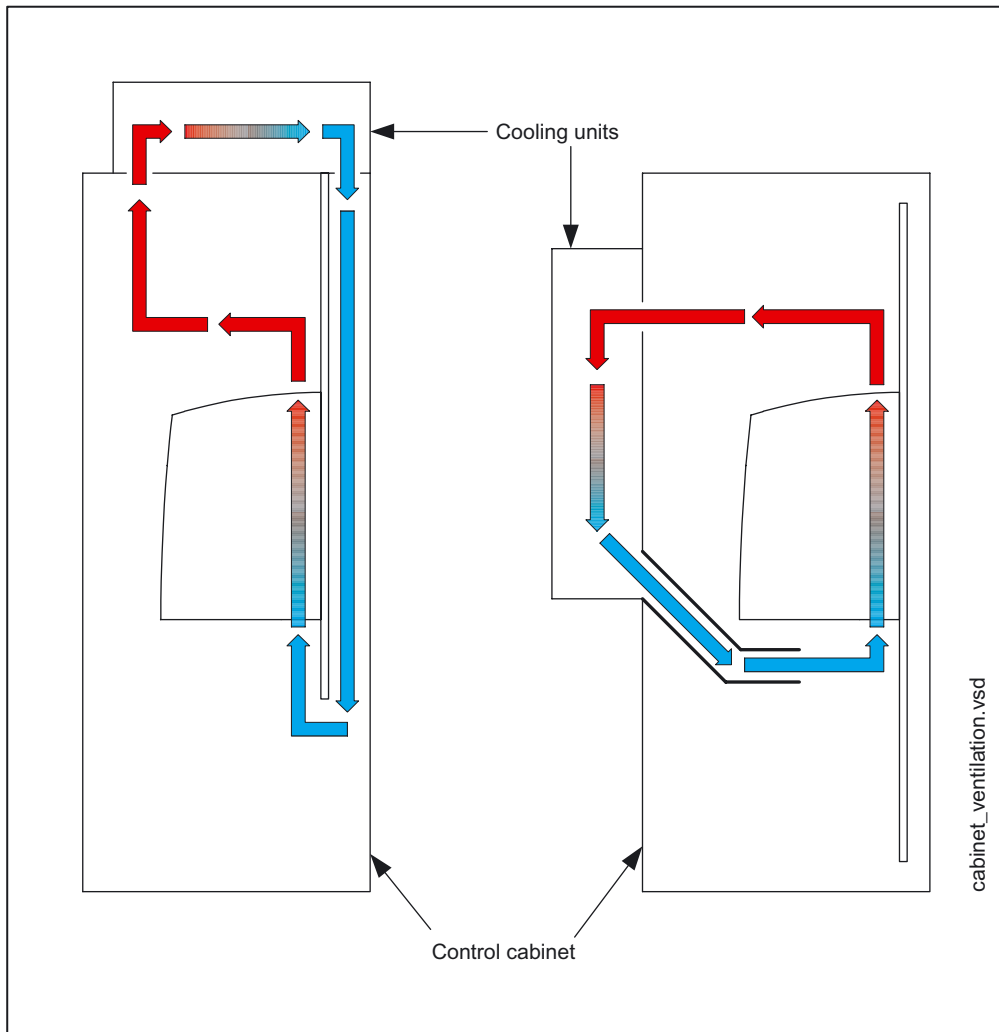

Figure 9-4 Examples of cabinet ventilation

**Caution**

The air guidance and arrangement of the cooling equipment must be chosen in such a way as to prevent condensation from forming.

If necessary, cabinet enclosure heating may have to be installed.

If air conditioners are used, the relative air humidity of the expelled air increases as the air in the air conditioner cools and may exceed the dew point. If the relative humidity of the air entering the SINAMICS equipment is over 80% for an extended period of time, the insulation in the equipment may fail to function properly due to electrochemical reactions (refer to System Overview). Using air baffle plates, for example, you must ensure that the cold air expelled from the air conditioner mixes with warm air in the cabinet before it enters the equipment. This reduces the relative air humidity to uncritical values.

### 9.7.3 Power Loss of Components in Rated Operation

The following table shows the power loss for components. The characteristic values apply for the following conditions:

- Line supply voltage for Power Modules 1-ph. 200 V AC to 3-ph. 380 V to 480 V AC  $\pm 10\%$ .
- Pulse frequency of the Power Modules 4 kHz
- Rated pulse frequency of the Power Modules 8 kHz
- Operating components at their rated power

Table 9-8 Overview of power losses

	Unit	Power loss
<b>Control Units</b>		
CU320	W	20
CU310 DP	W	20
CU310 PN	W	20
CUA31	W	7.2
Line reactors for Power Modules Blocksize	W	Refer to Line reactors, Chapter "Technical data".
Line filter for Power Modules Blocksize	W	Refer to Line filter, Chapter "Technical data".
PM340	W	Refer to Power Modules, Chapter "Technical data".
<b>Sensor Modules</b>		
SMC10	W	< 10
SMC20	W	< 10



## Service and maintenance

### 10.1 Safety information



---

**Danger**

Only Siemens customer service, repair centers that have been authorized by Siemens or authorized personnel may repair drive equipment. All of the persons involved must have in-depth knowledge of all of the warnings and operating instructions as listed in this Manual.

All damaged parts or components must be replaced only using parts and components that are listed in the relevant spare parts list.

---



---

**Danger**

Before starting any work, after the specified waiting time has elapsed, carefully measure the voltage! The voltage can be measured between the DC link terminals DCP and DCN and must be below 42.2 V DC.

---



---

**Danger**

If the auxiliary 230 V AC supplies are present, then a hazardous voltage is present at the components even when the main switch is in the open state.

---

## 10.2 Service and maintenance for components, Blocksize format

### 10.2.1 Replacing hardware components

---

#### Notice

Hardware components may only be replaced when in the no-voltage state!

---

The following components can be replaced with replacement/exchange components with the same Order No.:

- Power Modules
- DRIVE-CLiQ components
- Control Units

### 10.2.2 Replacing the fan

- CU310 DP: In order to replace the fan, the plastic housing must be removed by releasing all of the catches one after the other using a screwdriver. The fan can then be withdrawn from the front without requiring any tools and replaced.  
Only qualified trained personnel may replace the cU310 DP fan strictly adhering to ESD instructions.  
Qualified and trained personnel should also reset the operating hours counter of the fan to 0 at the same time.  
The fan can be ordered as spare part.
- CU310 PN: In order to replace the fan, the plastic housing must be removed by releasing all of the catches one after the other using a screwdriver. The fan can then be withdrawn from the front without requiring any tools and replaced.  
Only qualified trained personnel may replace the cU310 PN fan strictly adhering to ESD instructions.  
Qualified and trained personnel should also reset the operating hours counter of the fan to 0 at the same time.  
The fan can be ordered as spare part.
- PM340: For all frame sizes, the fans are accessible from the outside. For frame sizes A to C, a Phillips screwdriver is required.  
The fan can be ordered as spare part.
- The CUA31 does not have a fan.



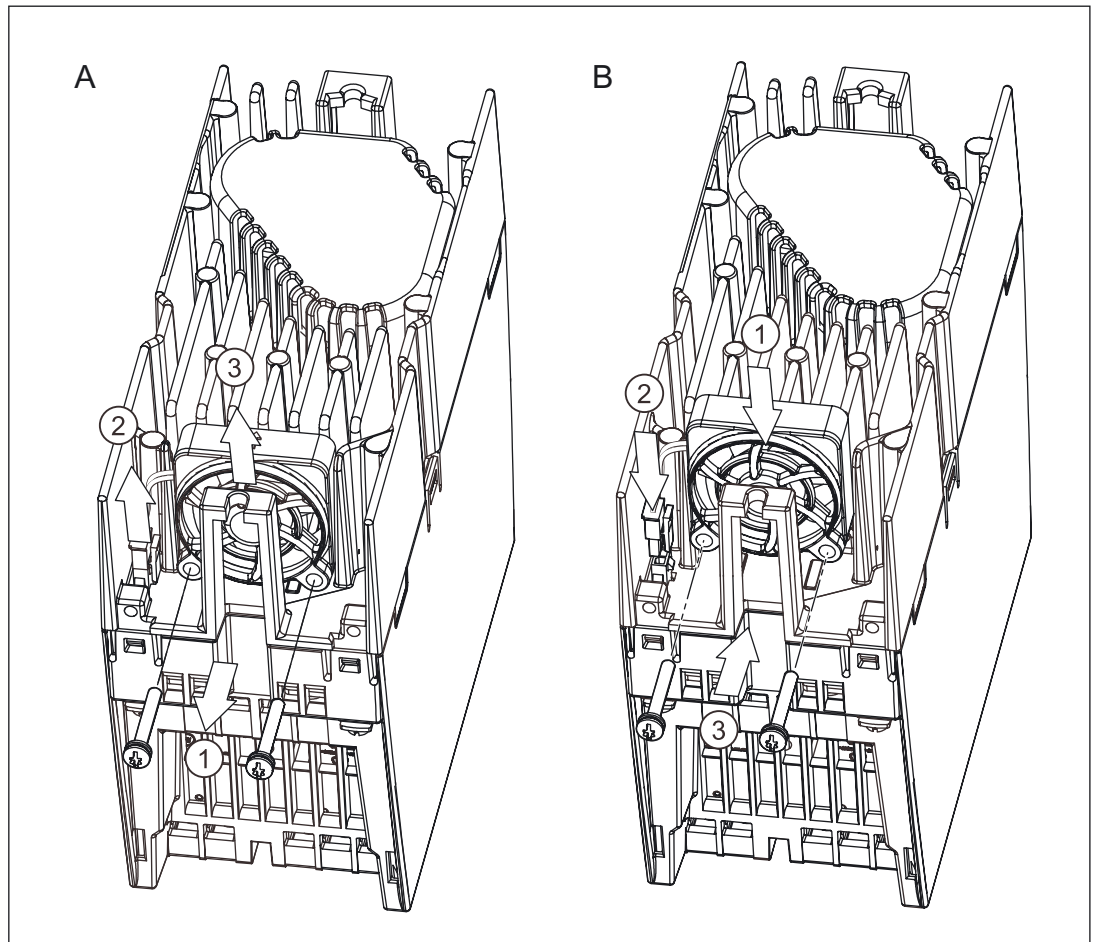

Figure 10-1 Replacing a fan for a Power Module PM340, frame size A

(tightening torque 0.4 Nm)

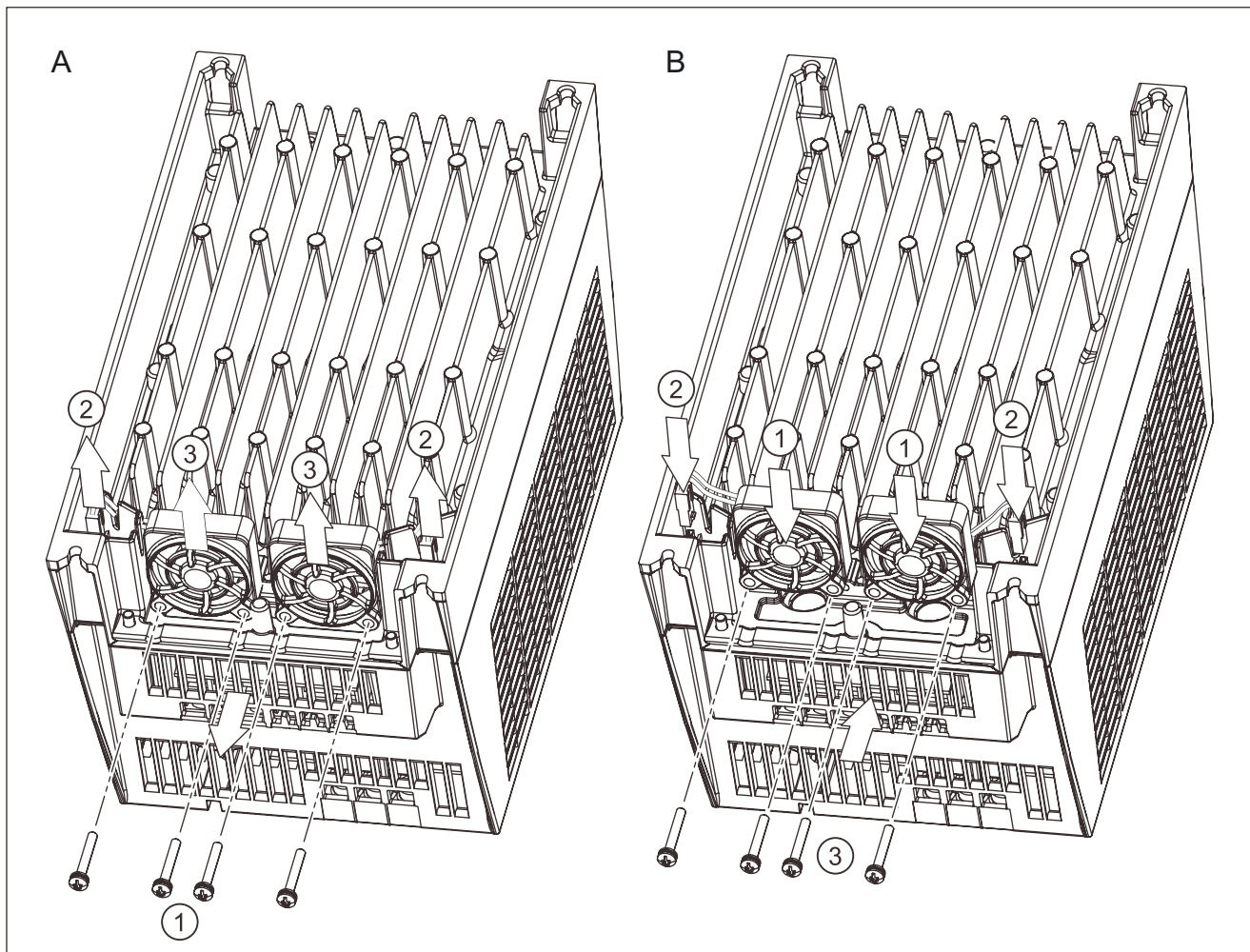

Figure 10-2 Replacing a fan for a Power Module PM340, frame sizes B and C

(tightening torque 0.4 Nm)

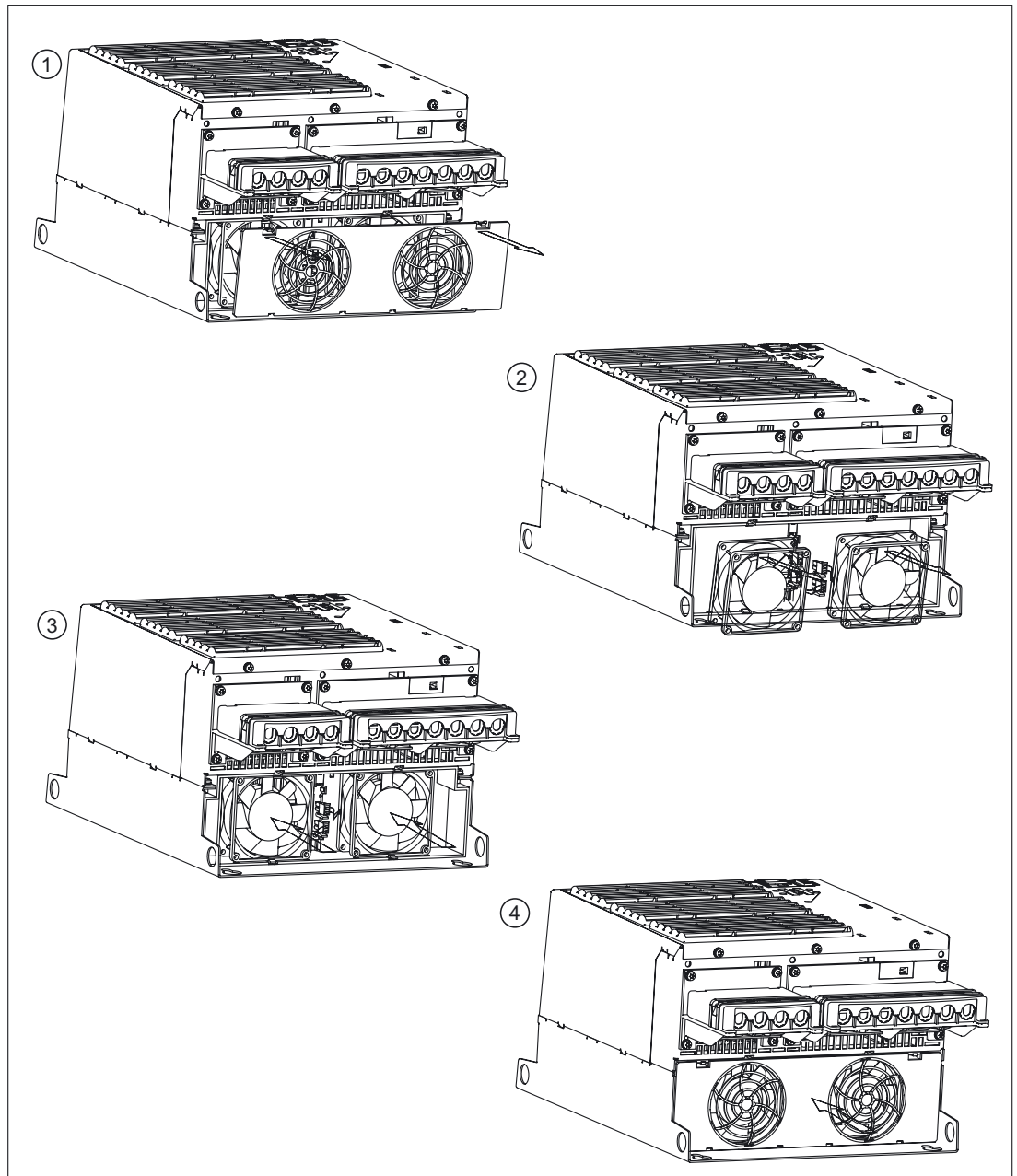

Figure 10-3 Replacing a fan for a Power Module PM340, frame sizes D and E

1. Removing the cover using a suitable tool.
2. Withdraw the two connectors shown and lift-out the fan.
3. Use the new fan and insert both connectors.
4. Close the protective cover.

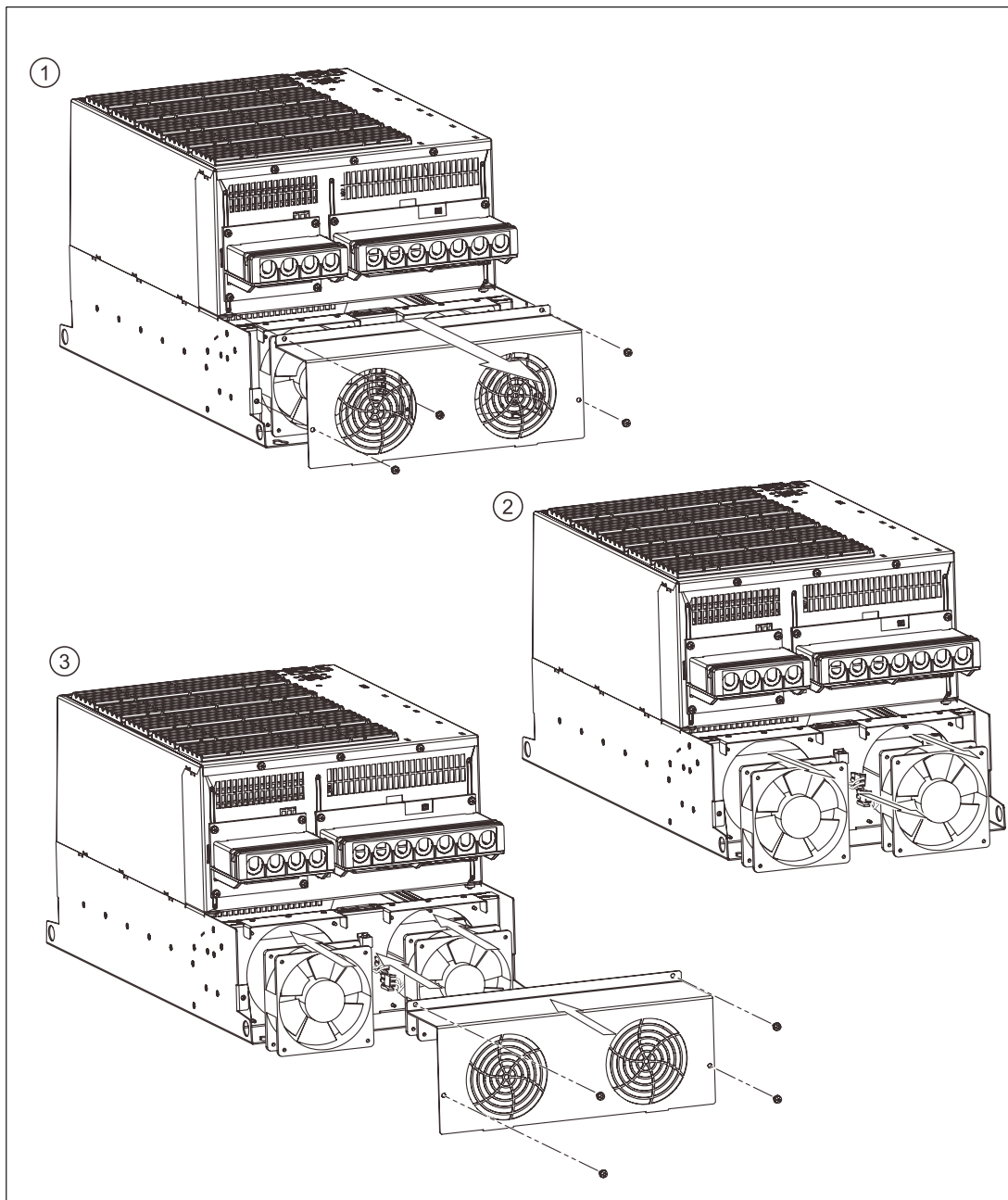

Figure 10-4 Replacing the fan for a Power Module PM340, frame size F

1. Release the screws and remove the cover.
2. Withdraw the two connectors shown and lift-out the fan.
3. Insert the new fan, locate both connectors, close the cover and tighten the screws (tightening torque, 3.0 Nm).

## 10.3 Service and maintenance for Chassis format components

Maintenance is intended to ensure that the equipment remains in the specified condition. Dirt and contamination must be removed regularly and parts subject to wear replaced.

The following points must generally be observed.

### Dust deposits

Dust deposits inside the device must be removed at regular intervals (or at least once a year) by qualified personnel in line with the relevant safety regulations. The unit must be cleaned using a brush and vacuum cleaner, and dry compressed air (max. 1 bar) for areas that cannot be easily reached.

### Ventilation

The ventilation openings in the device must never be obstructed. The fans must be checked to make sure that they are functioning correctly.

### Cable and screw terminals

Cable and screw terminals must be checked regularly to ensure that they are secure in position, and if necessary, retightened. Cabling must be checked for defects. Defective parts must be replaced immediately.

---

#### Note

The actual intervals at which maintenance procedures are to be performed depend on the installation conditions (cabinet environment) and the operating conditions.

Siemens offers its customers support in the form of a service contract. For further details, contact your regional office or sales office.

---

### 10.3.1 Maintenance

Servicing involves activities and procedures for maintaining and restoring the operating condition of the devices.

#### Required tools

The following tools are required for replacing components:

- Spanner or socket spanner (w/f 10)
- Spanner or socket spanner (w/f 13)
- Spanner or socket spanner (w/f 16/17)
- Spanner or socket spanner (w/f 18/19)
- Hexagon-socket spanner (size 8)
- Torque wrench up to 50 Nm
- Screwdriver size 1 / 2
- Screwdriver Torx T20
- Screwdriver Torx T30

#### Tightening torques for current-carrying parts

When securing connections for current-carrying parts (line supply, motor connections, busbars), you must observe the following tightening torques.

Table 10-1 Tightening torques for connecting current-carrying parts

Screw	Torque
M6	6 Nm
M8	13 Nm
M10	25 Nm
M12	50 Nm

## 10.3.2 Installation equipment

### Description

The installation equipment is used to install and remove the power blocks for Power Modules in the Chassis format.

It is used as an installation aid, which is placed in front of and secured to the module. The telescopic guide support allows the withdrawable device to be adjusted according to the height at which the power blocks are installed. Once the mechanical and electrical connections have been removed, the power block can be removed from the module, whereby the power block is guided and supported by the guide rails on the withdrawable devices.



Figure 10-5 Installation equipment

### Order No.

Order number for the installation device: 6SL3766-1FA00-0AA0.

### 10.3.3 Replacing components

#### 10.3.3.1 Safety information



---

**Danger**

When transporting the devices and replacing components, note the following:

- Some of the devices and components are heavy or top heavy.
  - Due to their weight, the devices must be handled with care by trained personnel.
  - Serious injury or even death and substantial material damage can occur if the devices are not lifted or transported properly.
- 



---

**Danger**

The equipment is operated with hazardous voltages

All connection work must be carried-out in a no-voltage condition!

All work on the units must be carried out by trained personnel only. Death, serious injury, or substantial material damage can result if these warnings are not taken into account.

Work on an open device must be carried out with extreme caution because external supply voltages may be present. The power and control terminals may be live even when the motor is not running.

Dangerously high voltage levels are still present in the cabinet up to five minutes after it has been disconnected due to the DC link capacitors. For this reason, the cabinet should not be opened until after a reasonable period of time has elapsed.

---



### 10.3.3.2 Replacing the Powerblock, Power Module, frame size FX

#### Replacing the Powerblock

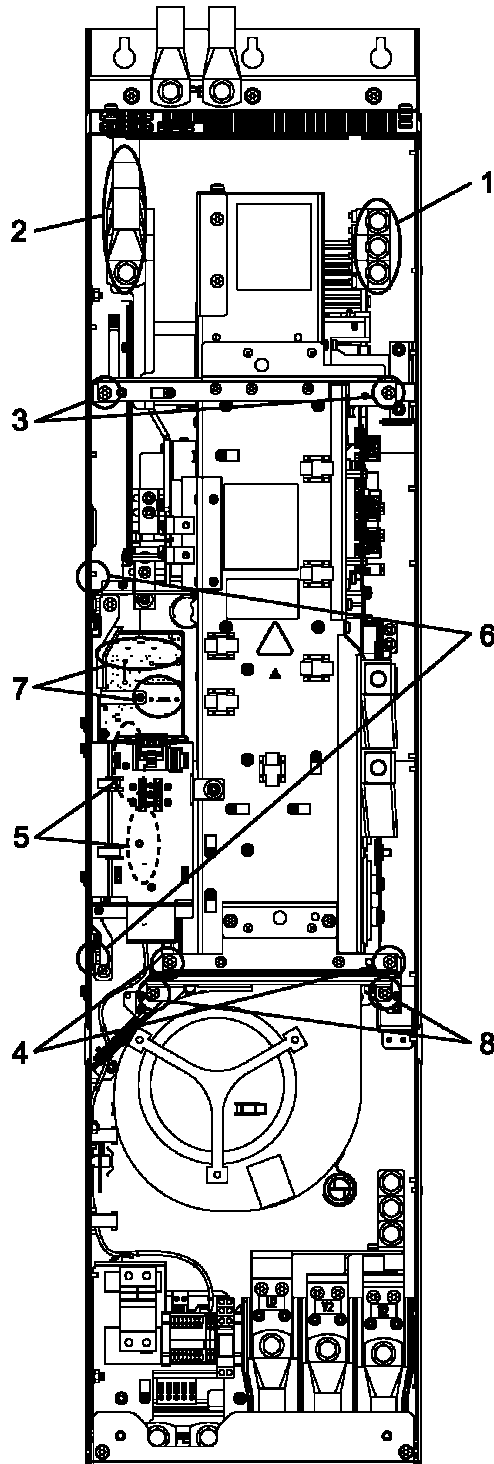

Figure 10-6 Replacing the Powerblock, Power Module, frame size FX

### Preparatory steps

- Disconnect the drive line-up from the power supply.
- Allow unimpeded access to the power block.
- Remove the front cover.

### Removal

The steps for the removal procedure are numbered in accordance with the previous diagram.

1. Unscrew the connection to the outgoing motor section (3 screws).
2. Unscrew the connection to the line supply (3 screws).
3. Remove the retaining screws at the top (2 screws).
4. Remove the retaining screws at the bottom (2 screws).
5. Remove the DRIVE-CLiQ cables and connections on –X41 / –X42 (5 plugs).
6. Remove the retaining elements of the electronic module (2 nuts) and carefully remove the electronics module.  
When removing the electronics module, 5 additional connectors (2 at the top, 3 at the bottom) must be removed one after the other.
7. Disconnect the plugs for the fiber optic cables and signal cables (5 plugs).
8. Unscrew the two retaining screws for the fan and attach the tool for de-installing the power block at this position.

You can now remove the power block.



---

#### Caution

When removing the power block, ensure that you do not damage any signal cables.

---

### Installation

To re-install the fan, carry out the above steps in reverse order.



---

#### Caution

You must observe the specified tightening torques.

Carefully re-establish the plug connections and ensure that they are secure.

---

### 10.3.3.3 Replacing the Powerblock, Power Module, frame size GX

#### Replacing the Powerblock

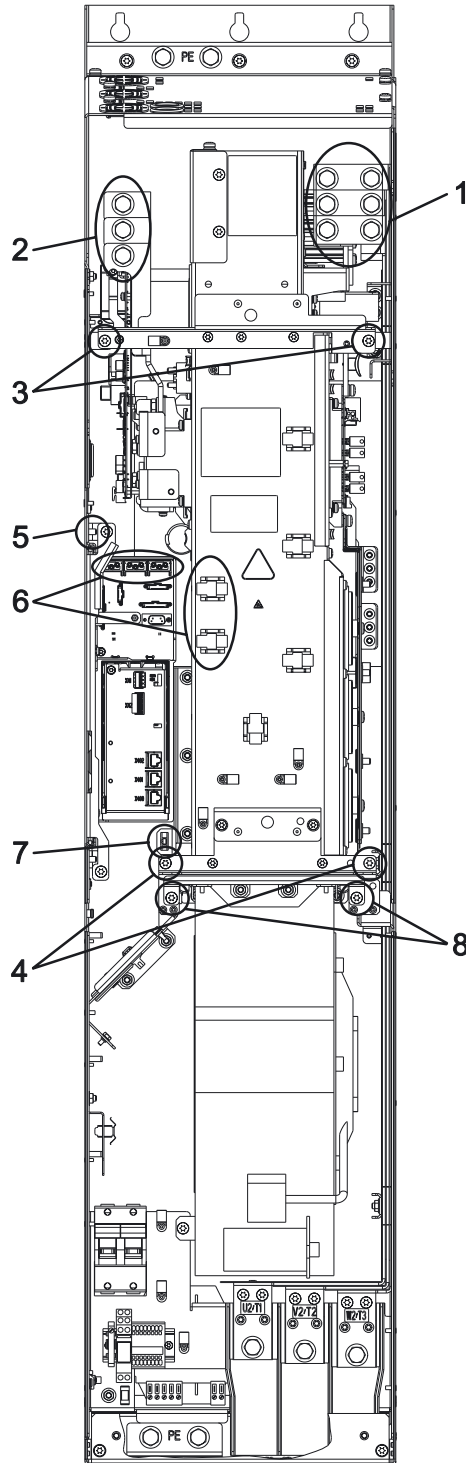

Figure 10-7 Replacing the Powerblock, Power Module, frame size GX

### Preparatory steps

- Disconnect the drive line-up from the power supply.
- Allow unimpeded access to the power block.
- Remove the front cover.

### Removal

The steps for the removal procedure are numbered in accordance with Fig. 8-3.

1. Unscrew the connection to the outgoing motor section (3 screws).
2. Unscrew the connection to the line supply (3 screws).
3. Remove the retaining screws at the top (2 screws).
4. Remove the retaining screws at the bottom (2 screws).
5. Remove the retaining element of the electronic module (1 nut) and carefully remove the electronics module.  
When removing the electronics module, 5 additional connectors (2 at the top, 3 at the bottom) must be removed one after the other.
6. Disconnect the connectors for the fiber optic cables (5 plugs) and release the cable connection for the signal cables (2 connectors).
7. Disconnect the plug for the thermocouple.
8. Unscrew the two retaining screws for the fan and attach the tool for de-installing the power block at this position.

You can now remove the power block.

---

#### Caution

When removing the power block, ensure that you do not damage any signal cables.

---

### Installation

To re-install the fan, carry out the above steps in reverse order.

---

#### Caution

You must observe the specified tightening torques.

Carefully re-establish the plug connections and ensure that they are secure.

---

### 10.3.3.4 Replacing the fan, Power Module, frame size FX

#### Replacing the fan

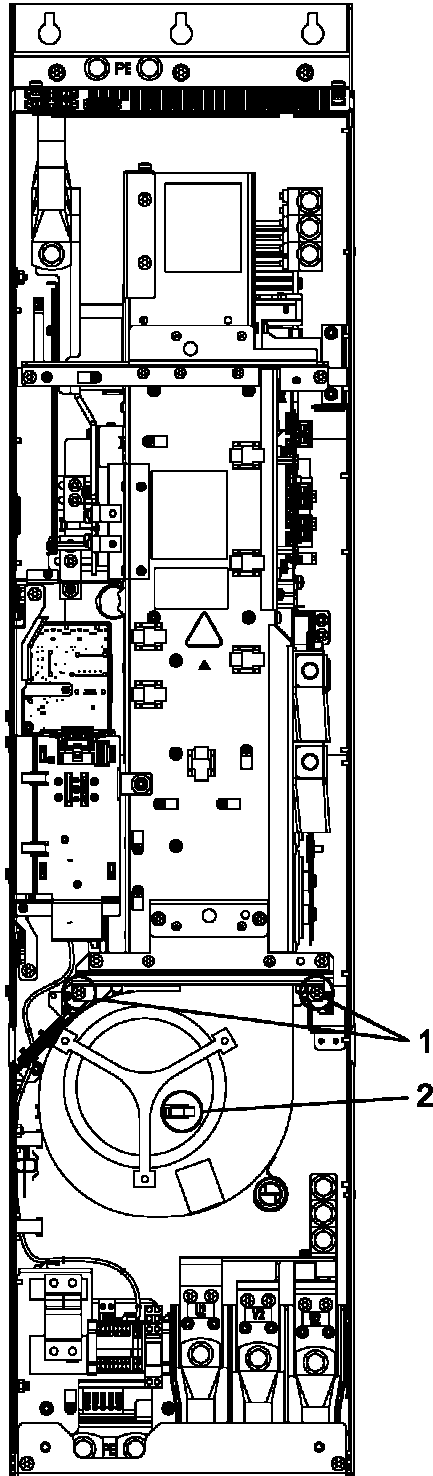

Figure 10-8 Replacing the fan, Power Module, frame size FX

### Description

The average service life of the device fans is 50,000 hours. In practice, however, the service life depends on other variables, including ambient temperature and the degree of cabinet protection and, therefore, may deviate from this value.

The fans must be replaced in good time to ensure that the device is available.

### Preparatory steps

- Disconnect the drive line-up from the power supply.
- Allow unimpeded access.
- Remove the front cover.

### Removal

The steps for the removal procedure are numbered in accordance with the previous diagram.

1. Remove the retaining screws for the fan (2 screws).
2. Disconnect the supply cables (1 x "L", 1 x "N").

You can now carefully remove the fan.

---

#### Caution

When removing the fan, ensure that the cables are not damaged.

---

### Installation

To re-install the fan, carry out the above steps in reverse order.

---

#### Caution

You must observe the specified tightening torques.

Carefully re-establish the plug connections and ensure that they are secure.

---

### 10.3.3.5 Replacing the fan, Power Module, frame size GX

#### Replacing the fan

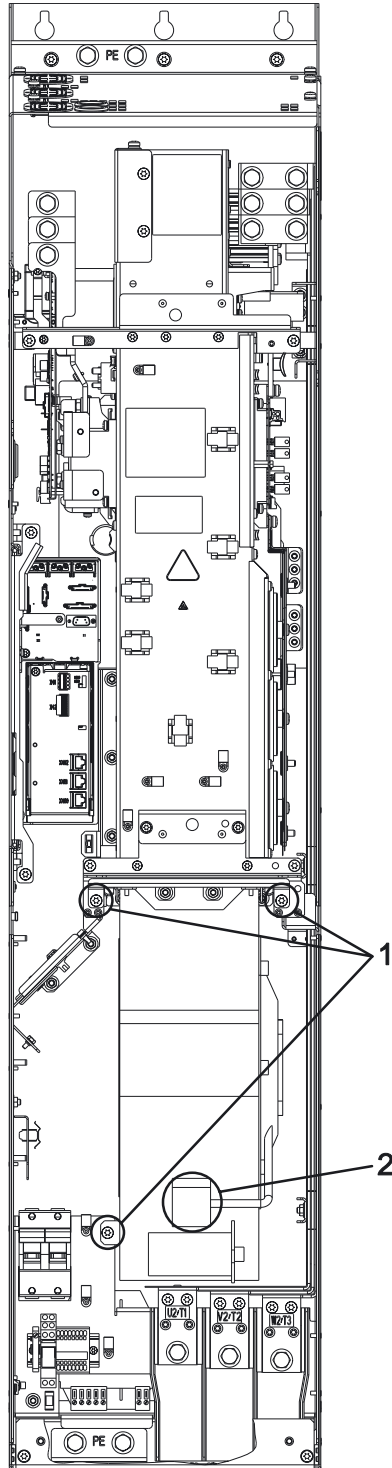

Figure 10-9 Replacing the fan, Power Module, frame size GX

## Description

The average service life of the device fans is 50,000 hours. In practice, however, the service life depends on other variables, including ambient temperature and the degree of cabinet protection and, therefore, may deviate from this value.

The fans must be replaced in good time to ensure that the device is available.

## Preparatory steps

- Disconnect the drive line-up from the power supply.
- Allow unimpeded access.
- Remove the front cover.

## Removal

The steps for the removal procedure are numbered in accordance with the previous diagram.

1. Remove the retaining screws for the fan (3 screws).
2. Disconnect the supply cables (1 x "L", 1 x "N").

You can now carefully remove the fan.

---

### Caution

When removing the fan, ensure that the cables are not damaged.

---

## Installation

To re-install the fan, carry out the above steps in reverse order.

---

### Caution

You must observe the specified tightening torques.

Carefully re-establish the plug connections and ensure that they are secure.

---



## 10.4 Spare parts

Table 10-2 Spare parts list AC/AC Chassis (status 31.03.2006)

	Order No.
<b>Powerblock</b>	
Powerblock for AC Drive/Power Module, 400V, 210A, complete	6SL3351-1AE32-1AA1
Powerblock for AC Drive/Power Module, 400V, 260A, complete	6SL3351-1AE32-6AA1
Powerblock for AC Drive/Power Module, 400V, 310A, complete	6SL3351-1AE33-1AA1
Powerblock for AC Drive/Power Module, 400V, 380A, complete	6SL3351-1AE33-8AA1
Powerblock for AC Drive/Power Module, 400V, 490A, complete	6SL3351-1AE35-0AA1
<b>CIB module</b>	
CIB for SINAMICS S Power Module, 400V, 210A	6SL3351-6TE32-1AA3
CIB for SINAMICS S Power Module, 400V, 260A	6SL3351-6TE32-6AA3
CIB for SINAMICS S Power Module, 400V, 310A	6SL3351-6TE33-1AA3
CIB for SINAMICS S Power Module, 400V, 380A	6SL3351-6TE33-8AA3
CIB for SINAMICS S Power Module, 400V, 490A	6SL3351-6TE35-0AA3
<b>Terminal block X9</b>	
Terminal strip X9, chassis unit AC/AC	A5E00379194
<b>Power supply PSB</b>	
Power supply 400V/500 V	6SL3352-6BE00-0AA1
<b>Fans</b>	
Spare fan for the CU310	6SL3064-0AC00-0AA0
Spare fan for Power Module, frame size A	1 x 6SL3200-0SF01-0AA0
Spare fan for Power Module, frame size B	2 x 6SL3200-0SF01-0AA0
Spare fan for Power Module, frame size C	2 x 6SL3200-0SF03-0AA0
Spare fan for Power Module, frame sizes D / E 38 A / 45 A and 75 A	1 x 6SL3200-0SF04-0AA0
Spare fan for Power Module, frame sizes D / E 60 A and 90 A	1 x 6SL3200-0SF05-0AA0
Spare fan for Power Module, frame sizes F 110 A and 145 A	1 x 6SL3200-0SF06-0AA0
Spare fan for Power Module, frame size F 178 A	1 x 6SL3200-0SF07-0AA0
<b>Fan, format FX</b>	
Fan, chassis unit frame size FX 400V, 210A	6SL3362-0AF00-0AA1
Fan, chassis unit frame size FX 400V, 260A	6SL3362-0AF01-0AA1
<b>Fan, format GX</b>	
Fan, chassis unit frame size GX, H and J 400V	6SL3362-0AG00-0AA1

	Order No.
<b>Fan fuse FX</b>	
Fan fuses, frame size FX 400V, 210A	6SL3352-7BE32-1AA1
Fan fuses, frame size FX 400V	6SL3352-7BE32-6AA0
<b>Fan fuse GX</b>	
Fan fuses, frame size GX 400V	6SL3352-7BE35-0AA0
<b>Fan transformer FX</b>	
Fan transformer, frame size FX 400V, 210A	6SL3352-7AE32-1AA1
Fan transformer, frame size FX 400V, 260A	6SL3352-7AE32-6AA1
<b>Fan transformer GX</b>	
Fan transformer, frame size GX 400V	6SL3352-7AE35-0AA1
<b>Door, format FX</b>	
Door SINAMICS Power Module, frame size FX	6SL3361-3AF02-0AA0
<b>Door, format GX</b>	
Door SINAMICS Power Module, frame size GX	6SL3361-3AG02-0AA0

# A

## List of abbreviations/acronyms

### A.1 List of abbreviations

Table A-1 List of abbreviations

Abbreviation	German	English
<b>A</b>		
A...	Warnung	Alarm
AC	Wechselstrom	Alternating Current
ADC	Analog-Digital-Konverter	Analog Digital Converter
AI	Analogeingang	Analog Input
ALM	Active Line Module	Active Line Module
AO	Analogausgang	Analog Output
AOP	Advanced Operator Panel	Advanced Operator Panel
APC	Advanced Positioning Control	Advanced Positioning Control
ASC	Ankerkurzschluss	Armature Short-Circuit
ASCII	Amerikanische Code-Norm für den Informationsaustausch	American Standard Code for Information Interchange
ASM	Asynchronmotor	Induction motor
<b>B</b>		
OC	Betriebsbedingung	Operating Condition
BERO	Firmenname für einen Näherungsschalter	Tradename for a type of proximity switch
BI	Binektoreingang	Binector Input
BIA	Berufsgenossenschaftliches Institut für Arbeitssicherheit	Berufsgenossenschaftliches Institut für Arbeitssicherheit (German Institute for Occupational Safety)
BICO	Binektor-Konnektor-Technologie	Binector Connector Technology
BLM	Basic Line Module	Basic Line Module
BOP	Basic Operator Panel	Basic Operator Panel
<b>C</b>		
C	Kapazität	Capacitance
C...	Safety-Meldung	Safety message
CAN	Controller Area Network	Controller Area Network
CBC	Kommunikationsbaugruppe CAN	Communication Board CAN
CBP	Kommunikationsbaugruppe PROFIBUS	Communication Board PROFIBUS
CD	Compact Disc	Compact Disc
CDS	Befehlsdatensatz	Command Data Set

List of abbreviations/acronyms

A.1 List of abbreviations

Abbreviation	German	English
CI	Konnectoreingang	Connector Input
CNC	Computerunterstützte numerische Steuerung	Computer Numerical Control
CO	Konnectorausgang	Connector Output
CO/BO	Konnector-/Binectorausgang	Connector Output/Binector Output
COB-ID	CAN Object-Identification	CAN Object-Identification
COM	Mittelkontakt eines Wechselkontaktes	Common contact of a change-over relay
CP	Kommunikationsprozessor	Communications Processor
CPU	Zentralbaugruppe	Central Processing Unit
CRC	Checksummenprüfung	Cyclic Redundancy Check
CSM	Control Supply Module	Control Supply Module
CU	Control Unit	Control Unit
<b>D</b>		
DAC	Digital-Analog-Konverter	Digital Analog Converter
DC	Gleichstrom	Direct Current
DCN	Gleichstrom negativ	Direct Current Negative
DCP	Gleichstrom positiv	Direct Current Positive
DDS	Antriebsdatensatz	Drive Data Set
DI	Digitaleingang	Digital Input
DI/DO	Digitaleingang/-ausgang bidirektional	Bidirectional Digital Input/Output
DMC	DRIVE-CLiQ Module Cabinet (Hub)	DRIVE-CLiQ Module Cabinet (Hub)
DO	Digitalausgang	Digital Output
DO	Antriebsobjekt	Drive Object
DPRAM	Speicher mit beidseitigem Zugriff	Dual-Port Random Access Memory
DRAM	Dynamischer Speicher	Dynamic Random Access Memory
DRIVE CLiQ	Drive Component Link with IQ	Drive Component Link with IQ
DSC	Dynamic Servo Control	Dynamic Servo Control
<b>E</b>		
EDS	Geberdatensatz	Encoder Data Set
EGB	Elektrostatisch gefährdete Baugruppen	Electrostatic Sensitive Devices (ESD)
ELP	Erdschlussüberwachung	Earth Leakage Protection
EMK	Elektromagnetische Kraft	Electromagnetic Force (EMF)
EMV	Elektromagnetische Verträglichkeit	Electromagnetic Compatibility (EMC)
EN	Europäische Norm	European Standard
EnDat	Geber-Schnittstelle	Encoder-Data-Interface
EP	Impulsfreigabe	Enable Pulses
EPOS	Einfachpositionierer	Basic positioner
ES	Engineering System	Engineering System
ESB	Ersatzschaltbild	Equivalent circuit diagram
ESR	Erweitertes Stillsetzen und Rückziehen	Extended Stop and Retract
<b>F</b>		
F...	Störung	Fault
FAQ	Häufig gestellte Fragen	Frequently Asked Questions

Abbreviation	German	English
FCC	Function Control Chart	Function Control Chart
FCC	Flussstromregelung	Flux Current Control
FEM	Fremderregter Synchronmotor	Separately excited synchronous motor
FEPROM	Schreib- und Lesespeicher nichtflüchtig	Flash-EPROM
FG	Funktionsgenerator	Function Generator
FI	Fehlerstrom	Residual Current
FP	Funktionsplan	Function diagram
FW	Firmware	Firmware
<b>G</b>		
GB	Gigabyte	Gigabyte
GC	Global-Control-Telegramm (Broadcast-Telegramm)	Global Control Telegram (broadcast telegram)
GSD	Gerätstammdatei: beschreibt die Merkmale eines PROFIBUS-Slaves	Device master file: describes the features of a PROFIBUS slave
GSV	Gate Supply Voltage	Gate Supply Voltage
<b>H</b>		
HF	Hochfrequenz	High Frequency
HFD	Hochfrequenzdrossel	High frequency reactor
HLG	Hochlaufgeber	Ramp-function generator
HMI	Mensch-Maschine-Schnittstelle	Human Machine Interface
HTL	Logik mit hoher Störschwelle	High Threshold Logic
HW	Hardware	Hardware
<b>I</b>		
i. V.	in Vorbereitung: diese Eigenschaft steht zur Zeit nicht zur Verfügung	In preparation: this feature is currently not available
IBN	Inbetriebnahme	Commissioning
I/O	Eingang/Ausgang	Input/Output
ID	Identifizierung	Identifier
IEC	Internationale Norm in der Elektrotechnik	International Electrotechnical Commission
IGBT	Bipolartransistor mit isolierter Steuerelektrode	Insulated Gate Bipolar Transistor
IL	Impulslöschung	Pulse suppression
IT	Drehstromversorgungsnetz ungeerdet	Insulated three-phase line supply
IVP	Interner Spannungsschutz	Internal Voltage Protection
<b>J</b>		
JOG	Tippen	Jogging
<b>K</b>		
KDV	Kreuzweiser Datenvergleich	Data cross-checking
KIP	Kinetische Pufferung	Kinetic buffering
Kp	Proportionalverstärkung	Proportional gain
KTY	Spezieller Temperatursensor	Positive temperature coefficient temperature sensor

List of abbreviations/acronyms

A.1 List of abbreviations

Abbreviation	German	English
<b>L</b>		
L	Induktivität	Inductance
LED	Leuchtdiode	Light Emitting Diode
LIN	Linear motor	Linear motor
LSB	Niederwertigstes Bit	Least Significant Bit
LSS	Netzschalter	Line Side Switch
LU	Längeneinheit	Length Unit
<b>M</b>		
M	Masse	Reference potential, zero potential
MB	Megabyte	Megabyte
MCC	Motion Control Chart	Motion Control Chart
MDS	Motordatensatz	Motor Data Set
MLFB	Maschinenlesbare Fabrikatebezeichnung	Machine-readable product designation
MMC	Mensch Maschine Kommunikation	Man Machine Communication
MSB	Höchstwertigstes Bit	Most Significant Bit
MSCY_C1	Zyklische Kommunikation zwischen Master (Klasse 1) und Slave	Master Slave Cycle Class 1
MT	Messtaster	Measuring probe
<b>N</b>		
N. C.	Nicht angeschlossen	Not Connected
N...	Keine Meldung oder Interne Meldung	No Report
NAMUR	Normenarbeitsgemeinschaft für Mess- und Regeltechnik in der chemischen Industrie	Standardization association for instrumentation and control in the chemical industry
NC	Öffner	Normally Closed contact
NC	Numerische Steuerung	Numerical Control
NEMA	Normengremium in USA (United States of America)	National Electrical Manufacturers Association
NM	Nullmarke	Zero Mark
NO	Schliesser	Normally Open contact
<b>O</b>		
OA	Open Architecture	Open Architecture
OEM	Original Equipment Manufacturer	Original Equipment Manufacturer
OLP	Busstecker für Lichtleiter	Optical Link Plug
OMI	Option Module Interface	Option Module Interface
<b>P</b>		
p...	Einstellparameter	Adjustable parameter
PcCtrl	Steuerungshoheit	Master Control
PDS	Leistungsteildatensatz	Power unit Data Set
PE	Schutzerde	Protective Earth
PELV	Schutzkleinspannung	Protective Extra Low Voltage
PEM	Permanenterregter Synchronmotor	Permanent-magnet synchronous motor
PG	Programmiergerät	Programming terminal
PI	Proportional Integral	Proportional Integral

Abbreviation	German	English
PID	Proportional Integral Differential	Proportional Integral Differential
PLC	Speicherprogrammierbare Steuerung (SPS)	Programmable Logic Controller
PLL	Baustein zur Synchronisierung	Phase Locked Loop
PNO	PROFIBUS Nutzerorganisation	PROFIBUS user organisation
PPI	Punkt zu Punkt Schnittstelle	Point to Point Interface
PRBS	Weißes Rauschen	Pseudo Random Binary Signal
PROFIBUS	Serieller Datenbus	Process Field Bus
PS	Stromversorgung	Power Supply
PSA	Power Stack Adapter	Power Stack Adapter
PTC	Positiver Temperaturkoeffizient	Positive Temperature Coefficient
PTP	Punkt zu Punkt	Point To Point
PWM	Pulsweitenmodulation	Pulse Width Modulation
PZD	PROFIBUS Prozessdaten	PROFIBUS process data
<b>Q</b>		
<b>R</b>		
r ...	Beobachtungsparameter (nur lesbar)	Display parameter (read only)
RAM	Speicher zum Lesen und Schreiben	Random Access Memory
RCCB	Fehlerstrom-Schutzschalter	Residual Current Circuit Breaker
RCD	Fehlerstrom-Schutzschalter	Residual Current Device
RJ45	Norm. Beschreibt eine 8-polige Steckverbindung mit Twisted-Pair Ethernet.	Standard Describes an 8-pole plug connector with twisted pair Ethernet.
RKA	Rückkühlanlage	Cooling system
RO	Nur lesbar	Read Only
RPDO	Receive Process Data Object	Receive Process Data Object
RS232	Norm. Beschreibt die Physik einer seriellen Schnittstelle.	Standard. Describes the physical characteristics of a serial interface.
RS485	Norm. Beschreibt die Physik einer digitalen seriellen Schnittstelle.	Standard Describes the physical characteristics of a digital serial interface.
RTC	Echtzeituhr	Real Time Clock
<b>S</b>		
S1	Dauerbetrieb	Continuous duty
S3	Aussetzbetrieb	Periodic duty
SBC	Sichere Bremsenansteuerung	Safe Brake Control
SOS	Sicherer Betriebsstopp	Safe Operational Stop
SSR	Sichere Bremsrampe	Safe Stop Ramp
SBT	Sicherer Bremsentest	Safe Brake Test
SCA	Sichere Nocke	Safe Cam
SDI	Sichere Richtung	Safe Direction
SE	Sicherer Software-Endschalter	Safe software limit switch
SG	Sicher reduzierte Geschwindigkeit	Safely reduced speed
SGA	Sicherheitsgerichteter Ausgang	Safety-relevant output
SGE	Sicherheitsgerichtetes Eingangssignal	Safe input signal
SH	Sicherer Halt	Safe standstill

List of abbreviations/acronyms

A.1 List of abbreviations

Abbreviation	German	English
SI	Safety Integrated	Safety Integrated
SIL	Sicherheitsintegritätsgrad	Safety Integrity Level
SLI	Sicheres Schrittmaß	Safely Limited Increment
SLM	Smart Line Module	Smart Line Module
SLP	Sichere Endlage	Safely Limited Position
SLS	Sicher reduzierte Geschwindigkeit	Safely Limited Speed
SLVC	Geberlose Vektorregelung	Sensorless Vector Control
SM	Sensor Module	Sensor Module
SMC	Sensor Module Cabinet	Sensor Module Cabinet
SME	Sensor Module External	Sensor Module External
SN	Sicherer Software-Nocken	Safe software cam
SOS	Sicherer Betriebshalt	Safe Operational Stop
SPC	Sollwertkanal	Setpoint Channel
SPS	Speicherprogrammierbare Steuerung	Programmable Logic Controller (PLC)
SS1	Safe Stop 1	Safe Stop 1
SS2	Safe Stop 2	Safe Stop 2
SSI	Synchron Serielle Schnittstelle	Synchronous Serial Interface
SSM	Sichere Geschwindigkeitsanzeige $n < n_x$	Safe Speed Monitoring $n < n_x$
SSR	Sichere Bremsrampe	Safe Stop Ramp
STO	Sicherer Halt	Safe Torque Off
STW	PROFIBUS Steuerwort	PROFIBUS control word
<b>T</b>		
TB	Terminal Board	Terminal Board
TIA	Totally Integrated Automation	Totally Integrated Automation
TM	Terminal Module	Terminal Module
TN	Drehstromversorgungsnetz geerdet	Grounded three-phase line supply
Tn	Nachstellzeit	Integral time
TPDO	Transmit Process Data Object	Transmit Process Data Object
TT	Drehstromversorgungsnetz geerdet	Grounded three-phase line supply
TTL	Transistor-Transistor-Logik	Transistor Transistor Logic
<b>U</b>		
UL	Underwriters Laboratories Inc.	Underwriters Laboratories Inc.
USV	Unterbrechungsfreie Stromversorgung	Uninterruptible Power Supply (UPS)
<b>V</b>		
VC	Vektorregelung	Vector Control
Vdc	Zwischenkreisspannung	DC link voltage
VdcN	Teilzwischenkreisspannung negativ	Partial DC link voltage negative
VdcP	Teilzwischenkreisspannung positiv	Partial DC link voltage positive
VDE	Verband Deutscher Elektrotechniker	Association of German Electrical Engineers
VDI	Verein Deutscher Ingenieure	Association of German Electrical Engineers
Vpp	Volt Spitze zu Spitze	Volt peak to peak
VSM	Voltage Sensing Module	Voltage Sensing Module



Abbreviation	German	English
<b>W</b>		
WEA	Wiedereinschaltautomatik	Automatic restart
WZM	Werkzeugmaschine	Machine tool
<b>X</b>		
XML	Erweiterbare Auszeichnungssprache (Standardsprache für Web-Publishing und Dokumentenmanagement)	Extensible Markup Language
<b>Y</b>		
<b>Z</b>		
ZK	Zwischenkreis	DC Link
ZSW	PROFIBUS status word	PROFIBUS status word



# Index

## A

Autotransformer, 2-5

## B

Basic Operator Panel 20 (BOP20), 7-1  
Brake Relay, 7-38  
Braking Modules, 4-8  
Braking resistors, Blocksize, 4-1  
Braking resistors, Chassis, 4-20

## C

Cabinet-Mounted Sensor Module 20 (SMC20), 7-30  
Cable Installation, 9-12  
Climatic ambient conditions, 1-7  
Components  
    Basic Operator Panel 20 (BOP20), 7-1  
    Brake Relay, 7-38  
    Braking Modules, 4-8  
    Braking resistors, Blocksize, 4-1  
    Braking resistors, Chassis, 4-20  
    Cabinet-Mounted Sensor Module 20 (SMC20), 7-30  
    Control Unit 310 DP (CU310 DP), 6-5  
    Control Unit 310 PN (CU310 PN), 6-22  
    Control Unit Adapter 31 (CUA31), 6-34  
    DRIVE-CLiQ cabinet gland, 8-1  
    DRIVE-CLiQ coupling, 8-6  
    dv/dt filter Chassis, 5-22  
    Line filters, 2-8  
    Line reactors, 2-15  
    Motor reactors, 5-16  
    Motor reactors, Blocksize, 5-1  
    Power Modules, Blocksize (PM340), 3-1  
    Power Modules, Chassis, 3-42  
    Safe Brake Relay, 7-42  
    Screening Kit, 8-10  
    Sensor Module Cabinet-Mounted 10 (SMC10), 7-21  
    Sinusoidal filter, Chassis, 5-19  
    Terminal Module 31 (TM31), 7-5

Control Unit 310 DP (CU310 DP), 6-5  
Control Unit 310 PN (CU310 PN), 6-22  
Control Unit Adapter 31 (CUA31), 6-34  
Cooling clearances, 3-6, 9-17

## D

Description of the interfaces  
    Control Unit 310 DP (CU310 DP), 6-7  
    Control Unit 310 PN (CU310 PN), 6-23  
    Control Unit Adapter 31 (CUA31), 6-36  
    Power Modules, Chassis, 3-44  
Dimension drawings  
    Blocksize line filter, 2-9  
    Blocksize line reactors, 2-16  
    Chassis line filter, 2-10  
    Chassis line reactors, 2-20  
    Control Unit 310 DP (CU311 DP), 6-17  
    Control Unit 310 PN (CU310 PN), 6-31  
    Control Unit Adapter 31 (CUA31), 6-38  
    Motor reactors, Blocksize, 5-2  
    Motor reactors, Chassis, 5-17  
    Power Modules, Blocksize (PM340), 3-18  
    Power Modules, Chassis, 3-50  
    Screening Kit, 8-12  
    Sensor Module Cabinet-Mounted 10 (SMC10), 7-27  
    Sinusoidal filter, Chassis, 5-20  
Dimension Drawings  
    DRIVE-CLiQ cabinet gland, 8-3  
    DRIVE-CLiQ Coupling, 8-8  
    Terminal Module 31 (TM31), 7-16  
DRIVE-CLiQ cabinet gland, 8-1  
DRIVE-CLiQ coupling, 8-6  
dv/dt filter Chassis, 5-22

## E

Electrical Connections  
    Terminal Module 31 (TM31), 7-18  
EMC Directive, 9-11  
Equipotential Bonding, 9-15  
ESD information, vi

## H

Heat dissipation, 9-17  
Hotline, v

## I

Installation  
    Basic Operator Panel 20 (BOP20), 7-4  
    Braking Modules, 4-14  
    DRIVE-CLiQ cabinet gland, 8-5  
Installation altitude, 1-8  
Isolating transformer, 2-6

## L

Line contactor, 9-4  
Line disconnecting device, 9-3  
Line filter, 2-8  
Line filter versions, 2-1  
Line frequency, 1-6  
Line reactor versions, 2-1  
Line reactors, 2-15

## M

Motor reactors, 5-16  
Motor reactors, Blocksize, 5-1  
Mounting  
    Screening Kit, 8-18

## O

Option module, brake control, 7-38  
Overcurrent, 9-8  
Overcurrent protection, 9-3

## P

Power loss, 9-21  
Power Modules, Blocksize (PM340), 3-1  
Power Modules, Chassis, 3-42  
Power supply, 9-7  
Power Supply Units, 9-6

## R

Repairs, 10-1  
Replacing the fan, 10-2

## S

Safe Brake Relay, 7-42  
Safety information  
    Control Unit Adapter 31 (CUA31), 6-34  
    DRIVE-CLiQ cabinet gland, 8-1, 8-6  
    Line filters, 2-8  
    Line reactors, 2-15  
    Power Modules, Chassis, 3-43  
Safety Information  
    DRIVE-CLiQ cabinet gland, 8-1, 8-6  
Screening Kit, 8-10  
Screw terminals, 9-16  
Sensor Module Cabinet-Mounted 10 (SMC10), 7-21  
Service and maintenance, 10-2  
Shielding, 8-10  
Sinusoidal filter, Chassis, 5-19  
Spare parts, 10-19  
Standards, 1-8  
Support, v  
System data, 1-6

## T

Technical data  
    Basic Operator Panel 20 (BOP20), 7-5  
    Blocksize line filter, 2-14  
    Blocksize line reactors, 2-27  
    Braking Modules, 4-19  
    Braking resistors, 4-22  
    Braking resistors, Blocksize, 4-6  
    Chassis line filter, 2-14  
    Control Unit 310 DP (CU310 DP), 6-21  
    Control Unit 310 PN (CU310 PN), 6-33  
    Control Unit Adapter 31 (CUA31), 6-40  
    DRIVE-CLiQ cabinet gland, 8-6  
    DRIVE-CLiQ Coupling, 8-9  
    Line reactors, 2-29  
    Motor reactors, 5-18  
    Motor reactors Chassis, 5-18  
    Motor reactors, Blocksize, 5-13  
    Power Modules Blocksize, 3-30  
    Power Modules Chassis, 3-54  
    Sensor Module Cabinet-Mounted (SMC10), 7-29  
    Sinusoidal filter, Chassis, 5-21  
    Terminal Module 31 (TM31), 7-20  
Terminal Module 31 (TM31), 7-5

## V

Ventilation, 9-19

To  
 SIEMENS AG  
 A&D MC BMS  
 Postfach 3180  
 D-91050 Erlangen  
 Tel.: +49 (0) 180 / 5050 - 222 (Hotline)  
 Fax.: +49 (0) 9131 / 98 - 63315 (Documentation)  
 email: [motioncontrol.docu@siemens.com](mailto:motioncontrol.docu@siemens.com)

<b>Recommendation</b>
<b>Corrections</b>
for document:  SINAMICS S120 Equipment Manual (GH6)  Manufacturer / Service Documentation
Equipment Manual  Order no.: 6SL3097-2AL00-0BP0 Edition: 03/2006  Should you come across any printing errors when reading this publication, please notify us on this sheet. Suggestions for improvement are also welcome.

<b>From</b>
Name _____
Your company address/dept. _____
Address _____
Postal code: _____ City: _____
Phone: _____ / _____
Fax: _____ / _____

**Recommendations and/or suggestions**



# Overview of SINAMICS Documentation (03/2006)

## General Documentation/Catalogs

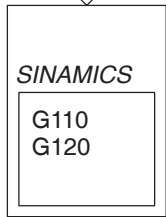

D11.1  
Converter Chassis Units  
0.12 – 3 kW

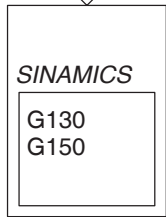

D11  
Converter Chassis Units  
Converter Cabinet Units

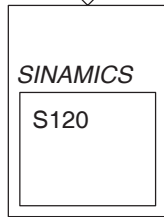

D21.1  
Chassis Units

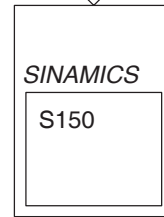

D21.3  
Vector Control Cabinet Units  
75 – 1200 kW

## Manufacturer/Service Documentation

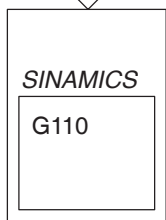

- Getting Started
- Operating Instructions
- List Manual

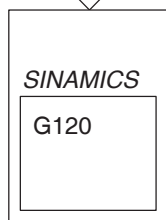

- Operating Instructions (Compact)
- Operating Instructions
- List Manual

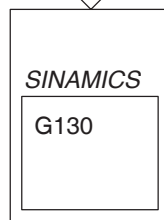

- Operating Instructions
- List Manual

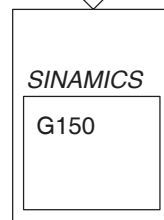

- Operating Instructions
- List Manual

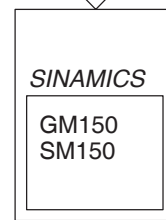

- Operating Instructions
- List Manual

## Manufacturer/Service Documentation

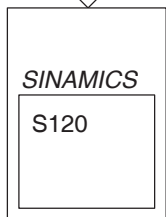

- Getting Started
- Equipment Manual for Control Units and Additional System Components
- Equipment Manual for Booksize Power Modules
- Equipment Manual Booksize Cold-Plate Power Sections
- Chassis Power Sections
- Equipment Manual AC DRIVE
- Commissioning Manual – Commissioning Manual CANopen
- Function Manual – Function Manual Free Function Blocks
- List Manual

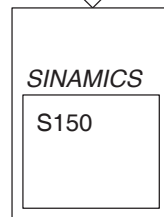

- Operating Instructions
- List Manual

## Manufacturer/Service Documentation

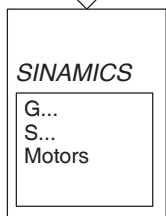

DOCONCD

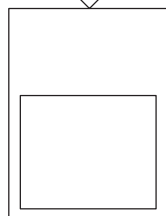

Configuration Manual  
Motors

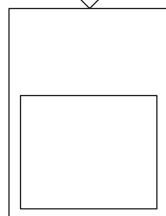

EMC  
Installation Guideline







Siemens AG  
Automation & Drives  
Motion Control Systems  
Postfach 3180, D-91050 Erlangen  
Germany

[www.siemens.com/motioncontrol](http://www.siemens.com/motioncontrol)

© Siemens AG 2006  
Subject to change without prior notice  
Order No.: 6SL3097-2AL00-0BP0

Printed in Germany