

SIEMENS

SINAMICS

SINAMICS V10

Operating Instructions

<u>Introduction</u>	1
<u>Safety notes</u>	2
<u>Description</u>	3
<u>Identification</u>	4
<u>Installation</u>	5
<u>Commissioning</u>	6
<u>Parameter list</u>	7
<u>Troubleshooting</u>	8
<u>Technical data</u>	9
<u>Replacing the fans</u>	A

SW version: V 01.63

08/2011

A5E03453178 (this is not an order number)

Legal information

Warning notice system

This manual contains notices you have to observe in order to ensure your personal safety, as well as to prevent damage to property. The notices referring to your personal safety are highlighted in the manual by a safety alert symbol, notices referring only to property damage have no safety alert symbol. These notices shown below are graded according to the degree of danger.

⚠ DANGER
indicates that death or severe personal injury will result if proper precautions are not taken.

⚠ WARNING
indicates that death or severe personal injury may result if proper precautions are not taken.

⚠ CAUTION
with a safety alert symbol, indicates that minor personal injury can result if proper precautions are not taken.

CAUTION
without a safety alert symbol, indicates that property damage can result if proper precautions are not taken.

NOTICE
indicates that an unintended result or situation can occur if the relevant information is not taken into account.

If more than one degree of danger is present, the warning notice representing the highest degree of danger will be used. A notice warning of injury to persons with a safety alert symbol may also include a warning relating to property damage.

Qualified Personnel

The product/system described in this documentation may be operated only by **personnel qualified** for the specific task in accordance with the relevant documentation, in particular its warning notices and safety instructions. Qualified personnel are those who, based on their training and experience, are capable of identifying risks and avoiding potential hazards when working with these products/systems.

Proper use of Siemens products

Note the following:

⚠ WARNING
Siemens products may only be used for the applications described in the catalog and in the relevant technical documentation. If products and components from other manufacturers are used, these must be recommended or approved by Siemens. Proper transport, storage, installation, assembly, commissioning, operation and maintenance are required to ensure that the products operate safely and without any problems. The permissible ambient conditions must be complied with. The information in the relevant documentation must be observed.

Trademarks

All names identified by ® are registered trademarks of Siemens AG. The remaining trademarks in this publication may be trademarks whose use by third parties for their own purposes could violate the rights of the owner.

Disclaimer of Liability

We have reviewed the contents of this publication to ensure consistency with the hardware and software described. Since variance cannot be precluded entirely, we cannot guarantee full consistency. However, the information in this publication is reviewed regularly and any necessary corrections are included in subsequent editions.

Table of contents

1	Introduction.....	5
2	Safety notes.....	7
3	Description.....	13
4	Identification.....	15
5	Installation.....	21
5.1	Mechanical installation.....	21
5.1.1	Mounting orientation and clearance.....	21
5.1.2	Wall mounting.....	23
5.1.3	Push-through mounting.....	25
5.1.4	Mounting the operator panel to cabinet door.....	31
5.2	Electrical installation.....	33
5.2.1	Interface definition.....	33
5.2.2	Connecting power supply to the motor.....	37
6	Commissioning	39
6.1	Typical connection modes.....	39
6.2	Application macros.....	56
6.3	Operator panel overview.....	58
6.3.1	Function overview of operator panel.....	59
6.3.2	Various data displays.....	60
6.3.3	Displays during inverter initialization stage.....	62
6.4	Quick commissioning.....	63
6.5	Inverter status display.....	65
6.6	Overview of various operation modes.....	66
6.6.1	Operation mode ① - Quick motor data setting.....	66
6.6.2	Operation mode ② - Connection macro selection.....	67
6.6.3	Operation mode ③ - Application macro selection.....	69
6.6.4	Operation mode ④ - Common application macro specific parameter setting.....	70
6.6.5	Operation mode ⑤ - Access all the parameters.....	71
6.7	Factory reset.....	72
6.8	Cloning parameters with the operator panel.....	73
7	Parameter list.....	75
8	Troubleshooting.....	107
9	Technical data.....	115
A	Replacing the fans.....	119
	Index.....	123

Introduction

Purpose of this manual

This manual provides customers with information about the proper installation, connecting, commissioning, operation and maintenance of the SINAMICS V10 inverter.

Internet addresses for SINAMICS V10

You can obtain continually updated information about the product at

SIEMENS Website for the SINAMICS V10 Inverters (<http://www.ad.siemens.com.cn/products/sd>)

You can download the SINAMICS V10 user documentation at

SIEMENS Website for the SINAMICS V10 User Documentation (<http://www.ad.siemens.com.cn/download>)

Technical support

In case of any questions concerning the product, contact your local distributor.

This chapter lists safety instructions which apply when handling the SINAMICS V10 inverter. These instructions are classified as **General, Identification, Transport & Storage, Installing, Connecting, Commissioning, Troubleshooting** and **Disposal**. Please read the information carefully, since it is provided for your personal safety and will also help prolong the service life of your inverter and the equipment connected to it.

General

 WARNING
<p>This equipment contains dangerous voltage and controls potentially dangerous rotating mechanical parts. Failure to work on the equipment/system in accordance with the instructions/procedures contained in this manual can result in death, severe personal injury or considerable damage to property.</p> <p>Only appropriately qualified personnel should work on the inverter system, and only after becoming acquainted with all the safety instructions, installation, connecting, operation and maintenance procedures contained in this manual.</p> <p>Any unauthorized modification of the equipment is NOT allowed.</p> <p>To fulfill the requirements of CE and Low Voltage directives, the equipment must be mounted in a metal cabinet and accessories like chokes should be used.</p> <p>The equipment will automatically restart after a mains blackout, brownout or fault if automatic restart (configured with parameter P1210) is activated, thus please check whether there is any necessity to set parameter P1200 (flying restart) again.</p> <p>When setting a connection mode code or resetting (via P0970) the inverter to factory default parameter values, it is NOT allowed to operate the inverter via external signal source.</p> <p>If the equipment has been stored for over 1 year before installation, you must recharge capacitors in the inverter first. For specific recharging requirements, consult your local distributor or local dealer.</p>

 **CAUTION**

Children and the general public must be prevented from accessing or approaching the equipment!

This equipment may only be used for the purpose specified by the manufacturer. Any unauthorized modification and the use of accessories that are not sold or recommended by the manufacturer of the equipment can cause fire, electric shock or injury.

The operator panel of the SINAMICS V10 inverter does NOT support plug and play. When you are in an attempt to switch between LOC and REM control modes via an external signal source, make sure that the communication between the operator panel and the inverter body unit is in good condition.

NOTICE

Keep this manual as a handy reminder and make them available to all users, if necessary.

Identification

 **WARNING**

Make sure that deliverables received are free from damage and in conformity with your purchase order. Should any damage or inconsistency with the purchase order be found, contact your local distributor or local dealer.

It's not permissible to put the equipment into use if it's damaged or short delivered.

Transport & Storage

 **CAUTION**

Transport and storage must meet the specified environmental conditions (see topic Technical data (Page 115) for details).

Installing

 **WARNING**

Risk of fire or electric shock. Do not install the equipment in an area subject to inflammables or combustibles, water or corrosion hazards.

⚠ CAUTION

Do not install the equipment in an area where it is likely to be exposed to constant vibrations, physical shocks or interference from electromagnetic field.

Risk of fire. Make sure that no foreign body (e.g., chips of wood or metal, dust, paper, etc.) falls into the inverter or lie on the heatsink of the inverter.

Keep sufficient clearance between inverters, one inverter and another device/the inner wall of the cabinet. (See topic "Mounting orientation and clearance (Page 21)" for clearance requirements).

The inverter **MUST NOT** be mounted horizontally.

Connecting

⚠ WARNING

The inverter must have been disconnected from the power supply for at least five minutes before you perform any wiring to the inverter.

Make sure that all connections are correct and reliable. Only permanently-wired input power connections are allowed and the inverter must be well grounded (IEC 536 Class 1, NEC and other applicable standards).

According to IEC 61800-5-1, a PDS (Power Drive System) with leakage currents over 3.5 mA requires a secure ground connection (e.g., at least 10 mm² Cu or multiple connection) or an automatic shutdown in case of a ground connection fault.

To avoid input power cable wires loosening or dropping from the mains input terminal connector, use a proper clamp to secure the input power connections.

If you have to install a Residual Current-operated protective Device (RCD), it must be an RCD type B.

Use of the protection from direct contact by means of SELV/PELV is permitted only in areas with equipotential bonding and in dry interior spaces. If these conditions are not present, other protective measures against electric shock must be taken, e.g., protection through protective impedances or limited voltage or use of protection class I and II.

Only PELV or SELV voltages may be connected at terminals with either PELV or SELV voltages (refer to EN 60204-1, Section 6.4).

⚠ CAUTION

The rated mains input voltage to the inverter must be 3 AC 400 V.

Never connect the mains input cable to the motor terminals U, V, W or connect the motor cable to the mains input terminals L1, L2, L3.

Route signal cables and power cables separately in different cable conduits. The signal cables shall be at least 10 cm away from the power cables.

Keep connecting cables away from rotating mechanical parts.

Commissioning

WARNING

Before switching the power on, make sure that the inverter system has been reliably installed and connected, and the mains voltage is within the allowable range.

Do not touch the motor shaft when the motor is running. Failure to comply may cause personal injury.

Risk of electric shock. DC link capacitors remain charged for five minutes after power-off. It is not allowed to open the equipment until five minutes has elapsed since power-off.

The following inverter terminals can carry dangerous voltages even if the inverter is inoperative:

- Mains input terminals L1, L2, L3
- Motor terminals U, V, W.

This equipment must not be used as an "emergency stop mechanism" (*see EN 60204, 9.2.5.4*).

It's not allowed to open the equipment or connect/disconnect the equipment during its operation.

When inverter is confirming a selected connection macro, cloning parameters or reset via P0970, it's **NOT** allowed to attempt to control the inverter operation via an external digital input.

CAUTION

Motor commissioning under loaded conditions may only be performed after motor commissioning under no-load (dry-run) conditions.

Do not touch the inverter heatsink, motor or other high-temperature parts during equipment operation or within a certain period since power disconnection. Failure to comply may cause personal injury.

Do not run or stop the inverter by switching on/off the mains supply frequently. This may cause damage to the equipment/system.

Troubleshooting

WARNING

Even if damage is only suspected (for example, water), don't operate the equipment but contact your distributor.

Do not touch terminals or disassemble cables until the inverter system has been disconnected for at least five minutes, because the inverter may remain charged during this period.

Troubleshooting may only be performed by personnel furnished with necessary expertise, or there is a risk of electric shock or damage to the equipment.

 CAUTION
Do not approach the machine after an input power failure! Certain parameter settings of the inverter can cause the machine to restart automatically.

Disposal

 WARNING
Disposal of the equipment must be made in accordance with regulations of the competent environmental protection administration on the disposal of electronic wastes.

Description

Overview

The SINAMICS V10 inverters are designed for controlling the speed of three phase AC asynchronous squirrel cage motors. The available inverter versions range from the 0.55 kW three phase output power to the 22 kW three phase output power.

The inverters are microprocessor-controlled and use state-of-the-art IGBT technology. A special pulse-width modulation method with selectable pulse frequency permits quiet motor operation. Comprehensive protective functions provide excellent inverter and motor protection.

SINAMICS V10 with its default factory settings is ideal for a large range of simple motor control applications. By configuring relevant parameters, you can use the inverter for some advanced motor control operations. In addition, the SINAMICS V10 inverters are also suitable for use in "stand-alone" applications or being integrated into "Automation Systems" via input/output signals.

Features

- Main characteristics
 - Easy installation and commissioning, simple cable connection
 - Can be operated on TNC, TNS, TT or IT mains systems
 - A comprehensive range of parameters enabling configuration for a wide range of simple applications
 - Compact design for fast installation
 - High switching frequencies for low-noise motor operation
- Performance characteristics
 - Fast Current Limitation (FCL) for normal operation under sudden load changes
 - Built-in DC braking mode
 - Compound braking to improve braking performance
 - V/f control with linear characteristic
 - V/f control with Flux Current Control (FCC)
 - V/f control with parabolic characteristic
 - Acceleration/deceleration times with programmable smoothing
 - Integrated PI controller for simple process control
- Protection characteristics
 - Short-circuit protection
 - Over-current protection
 - Inverter and motor over-temperature protection
 - Over-voltage and under-voltage protection
 - Load-side ground fault protection
 - Motor blocking protection
 - Parameter interlock

Identification

Scope of delivery

When opening the delivered SINAMICS V10 inverter package, check that the following components are included:

Table 4-1 Scope of delivery (SINAMICS V10 Inverter + Quick Start Guide + Certificate)

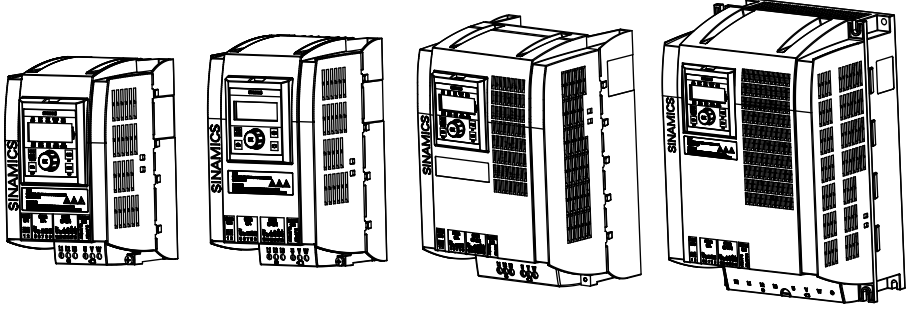
Component	Variant	Rated output power	MLFB (order number)	
SINAMICS V10 Inverter	Frame Size A	0.55 kW	6SL3217-0CE15-5UA1	
		0.75 kW	6SL3217-0CE17-5UA1	
		1.1 kW	6SL3217-0CE21-1UA1	
		1.5 kW	6SL3217-0CE21-5UA1	
	Frame Size B	2.2 kW	6SL3217-0CE22-2UA1	
		3.0 kW	6SL3217-0CE23-0UA1	
		4.0 kW	6SL3217-0CE24-0UA1	
	Frame Size C	5.5 kW	6SL3217-0CE25-5UA1	
		7.5 kW	6SL3217-0CE27-5UA1	
		11 kW	6SL3217-0CE31-1UA1	
	Frame Size D	15 kW	6SL3217-0CE31-5UA1	
		18.5 kW	6SL3217-0CE31-8UA1	
		22 kW	6SL3217-0CE32-2UA1	
				
	Frame Size A	Frame Size B	Frame Size C	Frame Size D
Quick Start Guide ¹⁾	English version	-	-	

¹⁾ The documentation identification number of the Quick Start Guide is A5E02583918 (this is not an order number).

Inverter rating plate

Check the information shown on the inverter rating plate against your purchase order. Viewing from the inverter front, the rating plating is located on the right side of the inverter housing.

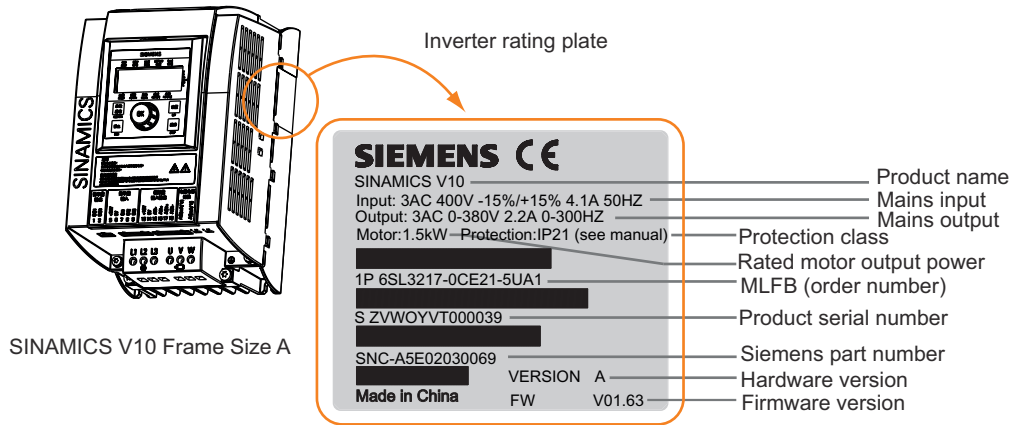

Figure 4-1 Inverter rating plate (example)

Inverter MLFB (order number) explanation

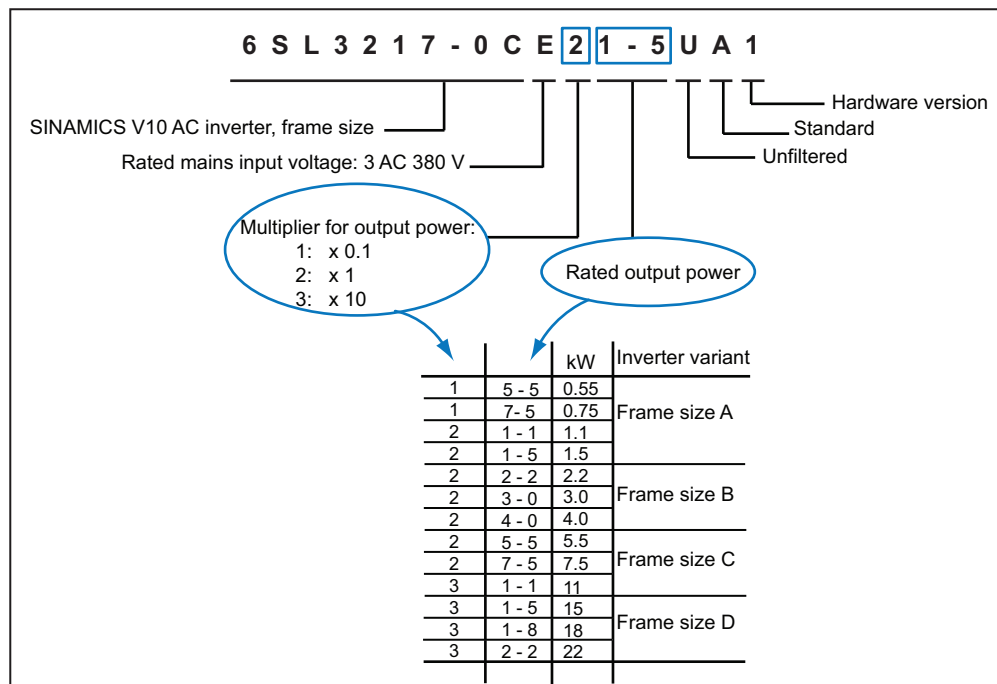

Figure 4-2 Inverter MLFB (Order Number) explanation

Rating plate on the rear of the operator panel

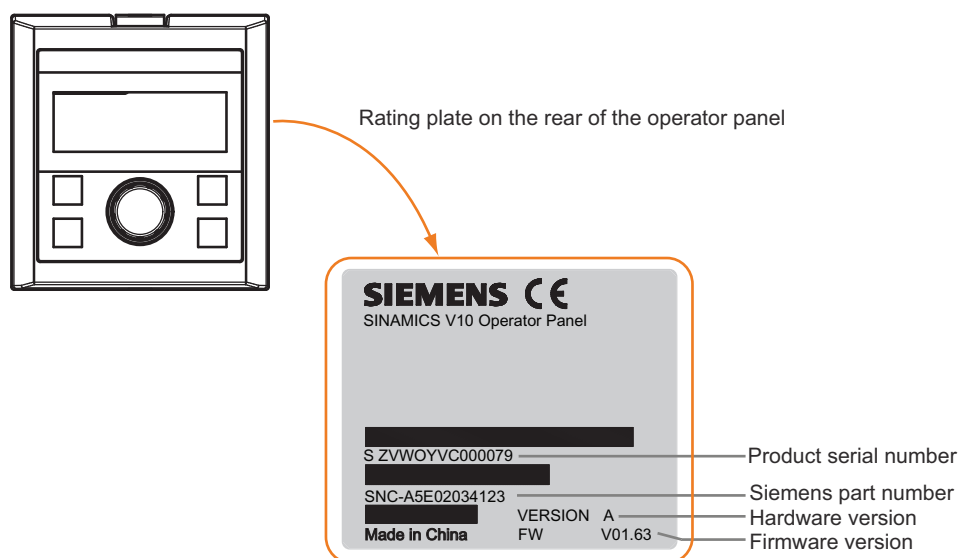

Figure 4-3 The operator panel rating plate

Note

Beside operator panel rating plate, there is a small label. This label indicates the firmware version of the operator panel.

Options

Option	Variant	MLFB (order number)
Push-through mounting components The push-through mounting components include: <ul style="list-style-type: none"> • Push-through mounting kit (1 set) ²⁾ • Production Information Sheet (1 piece) • Plastic rivets (2 pieces) • Metal back cover (1 piece) ³⁾ • Mounting screws: <ul style="list-style-type: none"> – Frame Size A: 4 x M5 screws – Frame Size B: 4 x M5 screws – Frame Size C: 8 x M5 screws – Frame Size D: 8 x M5 screws + 4 x M8 screws • Mounting nuts <ul style="list-style-type: none"> – Frame Size A: 4 x M5 nuts – Frame Size B: 4 x M5 nuts – Frame Size C: 8 x M5 nuts – Frame Size D: 8 x M5 nuts + 4 x M8 nuts 	Frame Size A specific	6SL3261-6AA00-0VA0
	Frame Size B specific	6SL3261-6AB00-0VA0
	Frame Size C specific	6SL3261-6AC00-0VA0
	Frame Size D specific	6SL3261-6AD00-0VA0
	Push-through mounting kit variants	

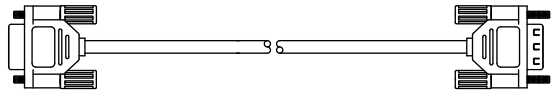
Option	Variant	MLFB (order number)			
Door mounting components The door mounting components include: <ul style="list-style-type: none"> • Connecting cable, 3-meter long (1 piece) • Production Information Sheet (1 piece) • M3 preassembled screw and washer assemblies (4 pieces) 	-	6SL3256-0VP00-0VA0			
	Connecting cable (inverter body unit to operator panel) To: inverter body unit  To: door-mounted operator panel				
Choke ⁴⁾ Line commutating choke: A line commutating choke is required to smooth spike pulses in power voltage, or voltage sags generated during the phase change of a bridge rectifier circuit; besides, a line commutating choke can also used to lower harmonic interference to inverter and power supply. If power impedance < 1%, a line commutating choke is a must to reduce current spikes. Output choke: An output choke is necessary for lowering varying rate of capacity current and voltage (dv/dt) if the length of motor cable is longer than 50m (shielded) or 100m (unshielded). For the detailed information about the length of motor cable, please refer to Technical data (Page 115)	Frame size	Rated out put power	Line commutating choke	Output choke	
	Frame Size A	0.55 kW	6SE6400-3CC00-2AD3 (6SE6400-3CR00-2AD3)	6SE6400-3TC00-4AD2	
		0.75 kW	6SE6400-3CC00-4AD3 (6SE6400-3CR00-4AD3)		
		1.1 kW	6SE6400-3CC00-6AD3 (6SE6400-3CR00-6AD3)		
	Frame Size B	2.2 kW	6SE6400-3CC01-0BD3 (6SE6400-3CR01-0BD3)	6SE6400-3TC01-0BD3	
		3.0 kW	6SE6400-3CC01-4BD3 (6SE6400-3CR01-4BD3)		
		4.0 kW	6SE6400-3CC02-2CD3 (6SE6400-3CR02-2CD3)		
	Frame Size C	5.5 kW	6SE6400-3CC03-5CD3 (6SE6400-3CR03-5CD3)	6SE6400-3TC03-2CD3	
		7.5 kW	6SE6400-3CC04-4DD0 (6SE6400-3CR04-4DD0)		
	Framze Size D	15 kW	6SE6400-3CC04-4DD0 (6SE6400-3CR04-4DD0)	6SE6400-3TC05-4DD0	
		18.5 kW	6SE6400-3CC04-4DD0 (6SE6400-3CR04-4DD0)	6SE6400-3TC03-8DD0	
		22 kW	6SE6400-3CC04-4DD0 (6SE6400-3CR04-4DD0)	6SE6400-3TC03-8DD0	
	Operating Instructions ⁵⁾	English version	-		

²⁾ The mounting kit consists of two mating parts. You can well engage both parts when installing.

³⁾ Only used for Frame Size D

⁴⁾ An order number without a bracket indicates that this choke is manufactured by a non-Chinese company, while an order number with a bracket indicates that this choke is supplied by a local Chinese company. You can make your selection according to your own needs.

⁵⁾ The documentation identification number of the Operating Instructions (English version) is A5E02583916 (this is not an order number).

Spare parts

Spare parts	Variant	MLFB (order number)
Fan components The fan components for Frame Size B include: <ul style="list-style-type: none"> • Fan (1 piece) • Production Information Sheet (1 piece) • M3 Mounting screws (2 pieces) The fan components for Frame Size C or Frame Size D include: <ul style="list-style-type: none"> • Fan (1 piece) • Production Information Sheet (1 piece) • M4 Mounting screws (2 pieces) • Spacers (2 pieces) 	Frame Size B specific	6SL3200-0VF02-0AA0
	Frame Size C specific	6SL3200-0VF03-0AA0
	Frame Size D specific	6SL3200-0VF04-0AA0
Operator panel	-	6SL3200-0VB01-0AA0

Installation

5.1 Mechanical installation

5.1.1 Mounting orientation and clearance

 WARNING
Depending on the mounting method selected, you MUST mount the inverter vertically
<ul style="list-style-type: none">• in a cabinet or• in a cabinet, but with the inverter heatsink extending outside the cabinet.
Do NOT mount the inverter horizontally in the cabinet.

Mounting orientation

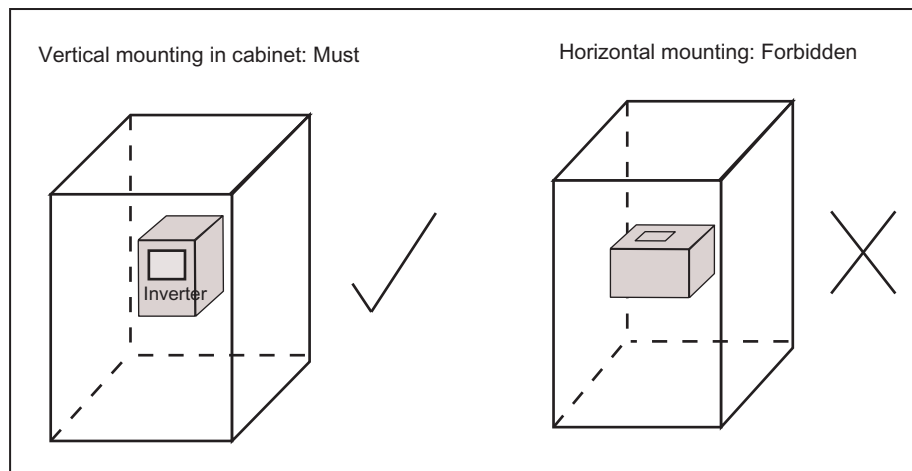

Figure 5-1 Mounting orientation

When performing vertical mounting, you can mount the inverter with an angle of 87° to 90° between inverter and horizontal surface. See figure below for details:

5.1 Mechanical installation

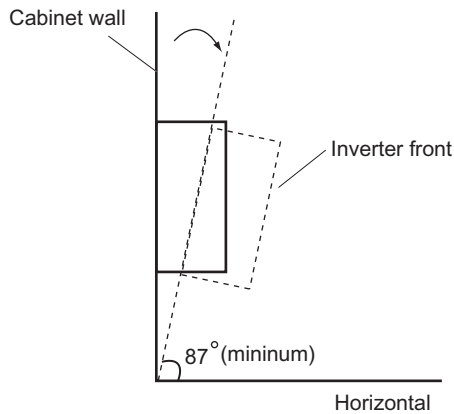

Figure 5-2 Allowed mounting angle between inverter and the horizon

Mounting clearance

You can mount inverters one next to another or one above another with the clearance below:

- Allow at least 100 mm clearance above and below the inverter..
- Allow at least specified clearance A (see Figure 5-3 and Table 5-1 below) between the inverters.

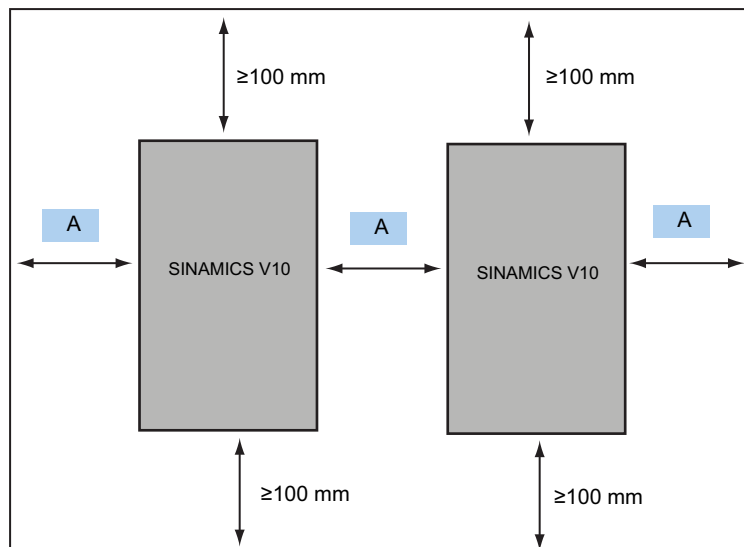

Figure 5-3 Inverter mounting clearance

Table 5-1 Requirements for inverter mounting clearance

Inverters positioned side by side	Minimum clearance ("A") in mm
Frame Size A ↔ Frame Size A	50
Frame Size B ↔ Frame Size A / B	50
Frame Size C ↔ Frame Size A / B / C	70
Frame Size D ↔ Frame Size A / B / C / D	75

5.1.2 Wall mounting

What does "Wall mounting" mean?

The term "Wall mounting" means:

1. The inverter mounts directly to a cabinet wall, without use of optional mounting kit.
2. The entire inverter including its heatsink mounts inside the cabinet.
3. You don't need an external fan to cool the inverter.

Mounting dimensions (outline dimensions + drill patterns)

You can drill holes in cabinet wall according to the drill patterns shown below. The inverter outline dimensions are also provided in the figure for your reference:

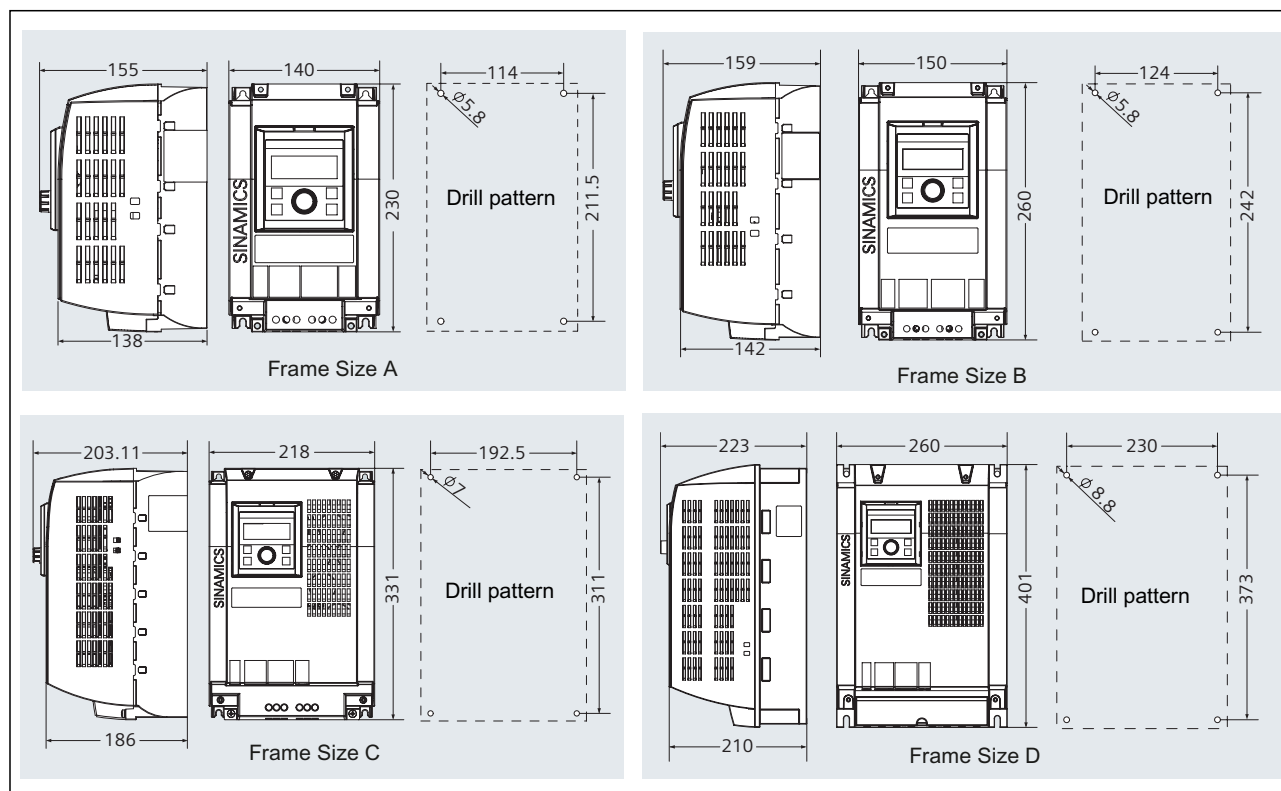

Figure 5-4 Mounting dimensions (in mm)

Table 5-2 Mounting torque requirements

Inverter variant	Holes to be drilled in cabinet wall	Fixing method	Tightening torque (Nm)
Frame Size A	4	4 x M5 screws and nuts	2.5
Frame Size B	4	4 x M5 screws and nuts	2.5

Installation

5.1 Mechanical installation

Inverter variant	Holes to be drilled in cabinet wall	Fixing method	Tightening torque (Nm)
Frame Size C	4	4 x M6 screws and nuts	2.5
Frame Size D	4	4 x M8 screws and nuts	2.5

Mounting sequence

Proceed the following procedure to complete your mounting of the inverter directly to cabinet wall:

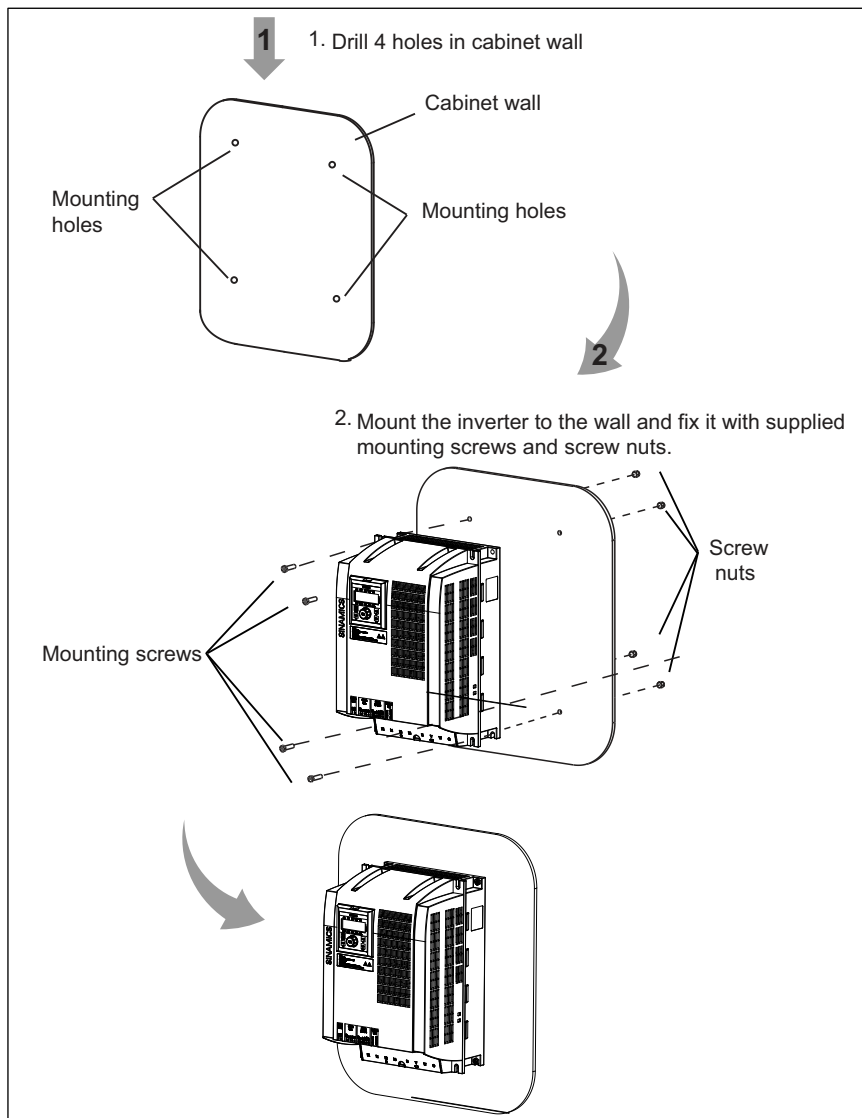

Figure 5-5 Mounting sequence (wall mounting)

Mounting the operator panel to cabinet door

The inverter has a removable operator panel. If necessary, you can remove the operator panel from the inverter and mount it to the cabinet door. (See topic "Mounting the operator panel to cabinet door (Page 31)" for details.)

5.1.3 Push-through mounting

What does "Push-through mounting" mean?

The term "Push-through mounting" means:

1. The inverter is mounted through cabinet wall, using an optional push-through mounting kit.
2. The inverter body unit mounts inside cabinet, while the heatsink extends outside the cabinet.
3. If necessary, you can use an external fan to cool the inverter.

Outline dimensions of SINAMICS V10

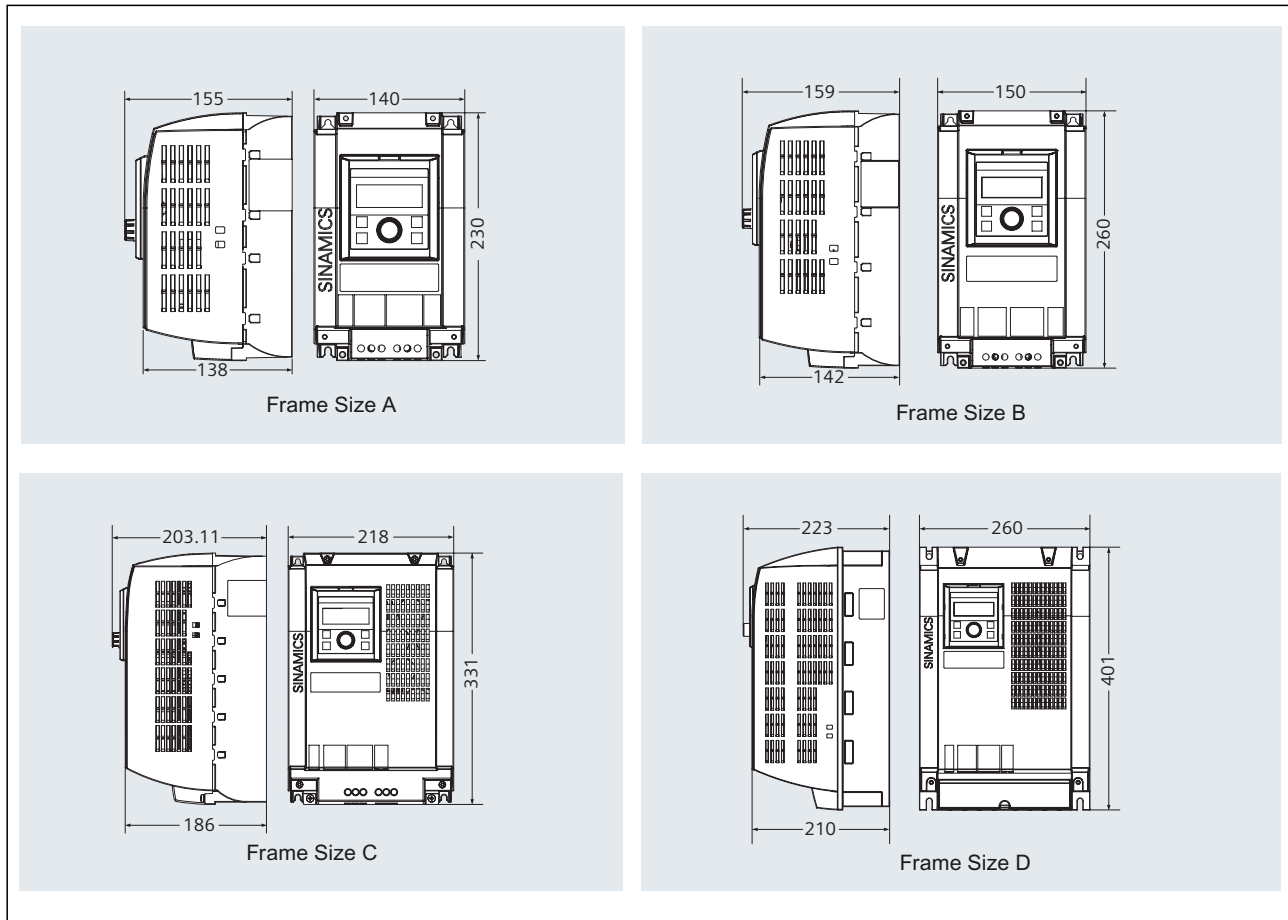

Figure 5-6 Outline dimensions of SINAMICS V10 (in mm)

Drill patterns and cut-out dimensions

Please drill holes and cut out an opening in cabinet wall according to the data specified in the figure below:

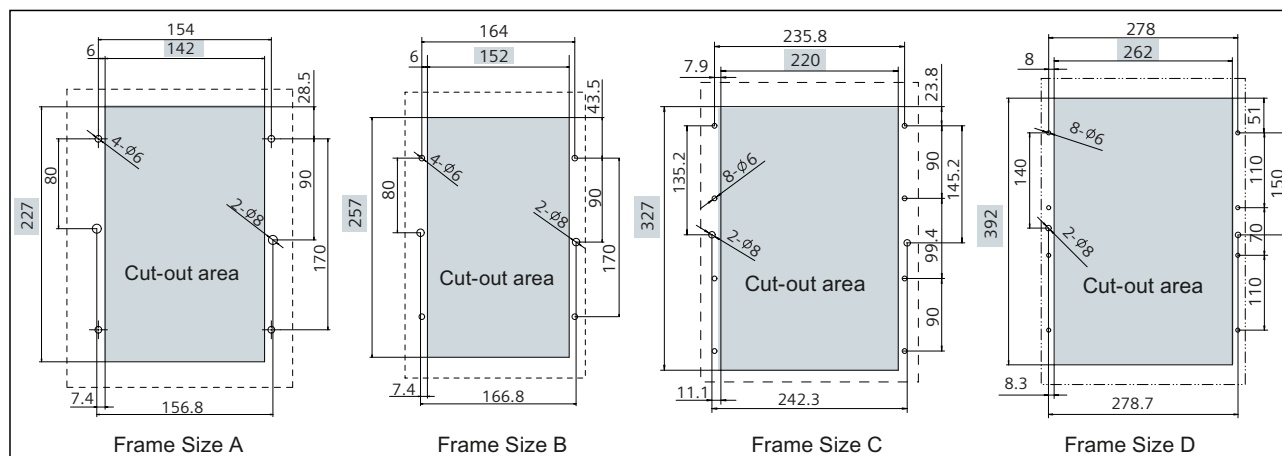

Figure 5-7 Drill pattern and cut-out dimensions (in mm)

Outline dimensions of optional mounting kits

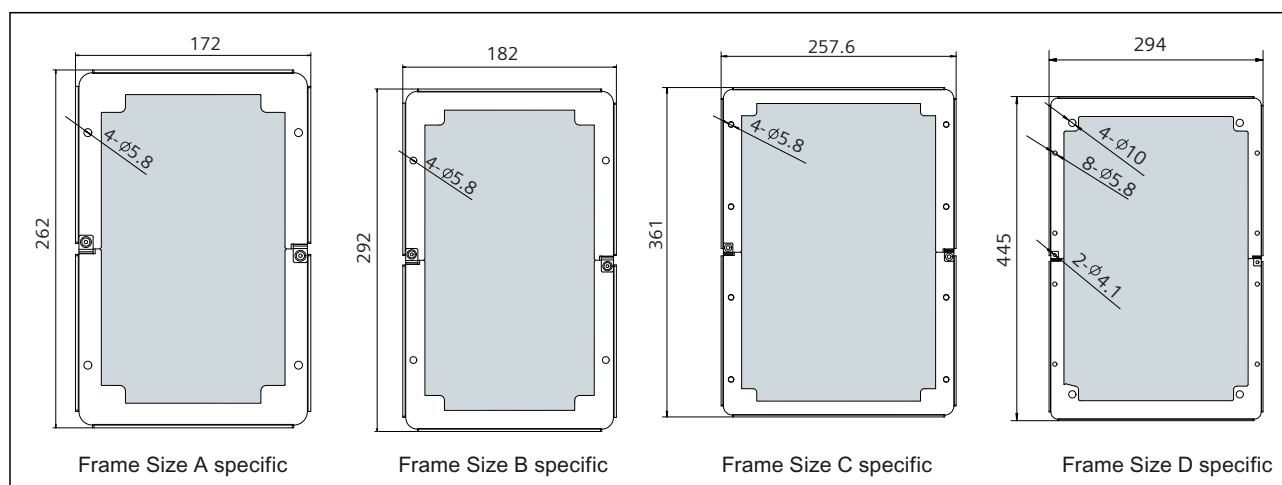

Figure 5-8 Outline dimensions of optional mounting kits (in mm)

Table 5-3 Mounting torque requirements

Inverter variant	Holes to be drilled in cabinet wall	Fixing method	Tightening torque (Nm)
Frame Size A	6	4 x M5 screws and nuts; 2 x plastic rivets	2.5
Frame Size B	6	4 x M5 screws and nuts; 2 x plastic rivets	2.5
Frame Size C	10	8 x M5 screws and nuts; 2 x plastic rivets	2.5

Installation

5.1 Mechanical installation

Inverter variant	Holes to be drilled in cabinet wall	Fixing method	Tightening torque (Nm)
Frame Size D	10	4 x M8 screws and nuts (for fixing the inverter to the push-through mounting kit) ; 2 x plastic rivets	2.5
		8 x M5 screws and nuts (for fixing the inverter to cabinet wall)	2.5
		4 x M4 screws (for fixing the metal back cover to the back of inverter)	0.8

Mounting sequence

Proceed the following procedure to complete your mounting of the inverter with optional mounting kit through cabinet wall:

Installation

5.1 Mechanical installation

Make a cut-out in the cabinet wall and drill holes in the wall.

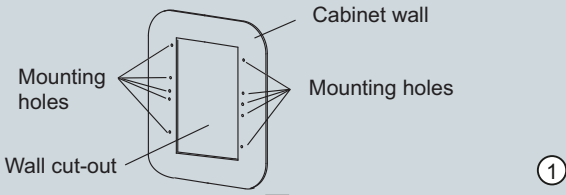

Slide in the direction of the arrow head each part of the mounting kit into the mounting slot of the inverter housing until both parts are well engaged.

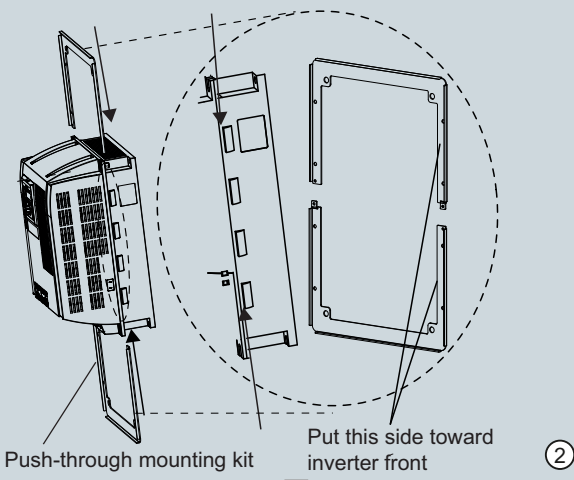

Insert the plastic rivets into the fully overlapped holes of the mating parts of the push-through mounting kit to interlock both parts in place.

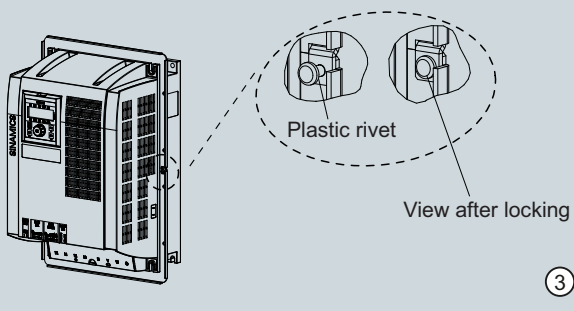

This step is necessary only when mounting Frame Size D.

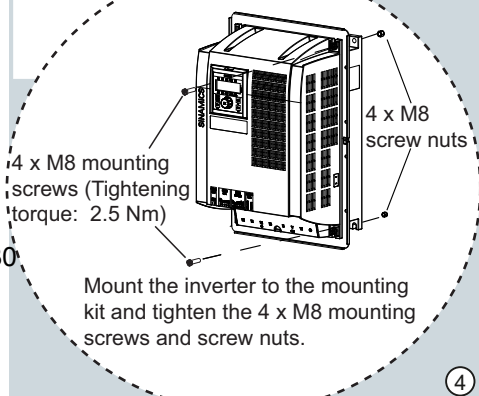

Mounting the inverter to the cabinet wall, then tighten the mounting screws and screw nuts delivered with the product.

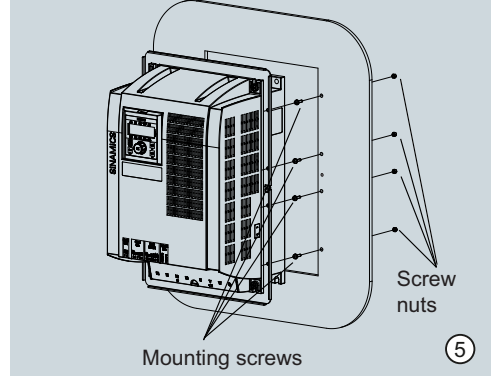

This step is also necessary only when mounting Frame Size D.

If necessary, using four M4 screws, mount the metal back cover to the back of inverter to improve cooling effect.

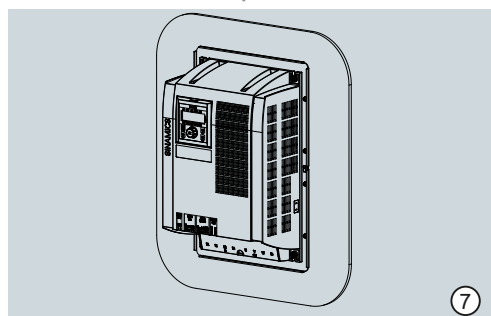
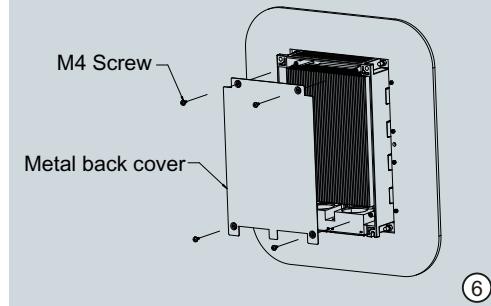

Mounting the operator panel to cabinet door

The inverter has a removable operator panel. If necessary, you can remove the operator panel from the inverter and mount it to the cabinet door. (See topic "Mounting the operator panel to cabinet door (Page 31)" for details.)

5.1.4 Mounting the operator panel to cabinet door

Mounting dimensions for door-mounted operator panel

You can detach the operator from inverter body unit and mount it to the cabinet door. This provides you with the possibility of remote operator panel operation.

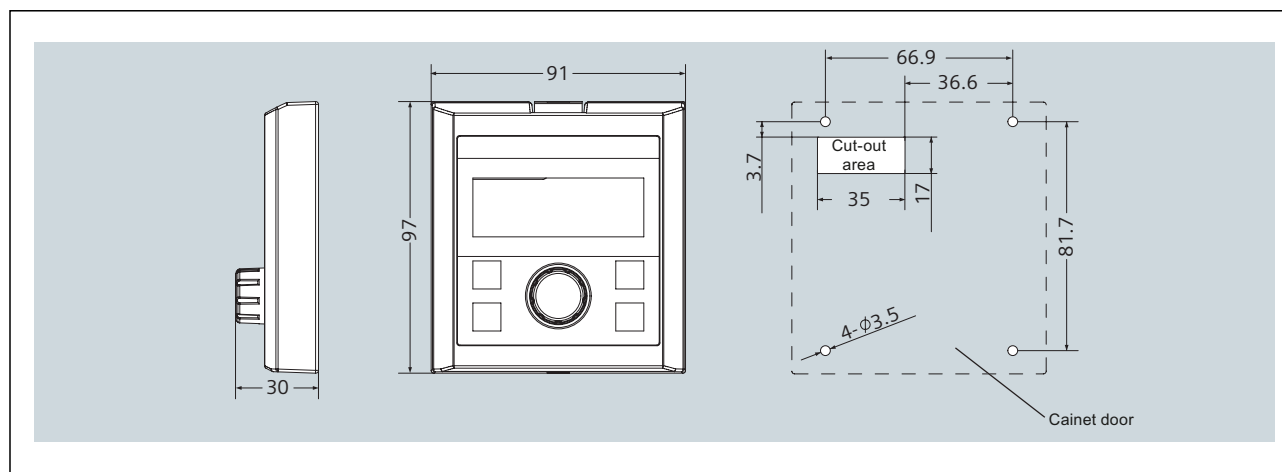

Figure 5-10 Mounting dimensions (outline dimensions + drill patterns + cut-out dimensions)

Table 5-4 Torques for fixing the operator panel to cabinet door

Holes to be drilled in cabinet door	Fixing method	Tightening torque (Nm)
4	4 x M3 preassembled screw and washer assemblies (screw length: 12 mm)	0.8

NOTICE
If the screw is damaged during mounting, you can select similar M3 preassembled screws and assemblies instead. But, make sure the screw length is between 12 mm and 18 mm.

Mounting the operator panel to cabinet door

Proceed the following procedure to mount the operator panel to cabinet door:

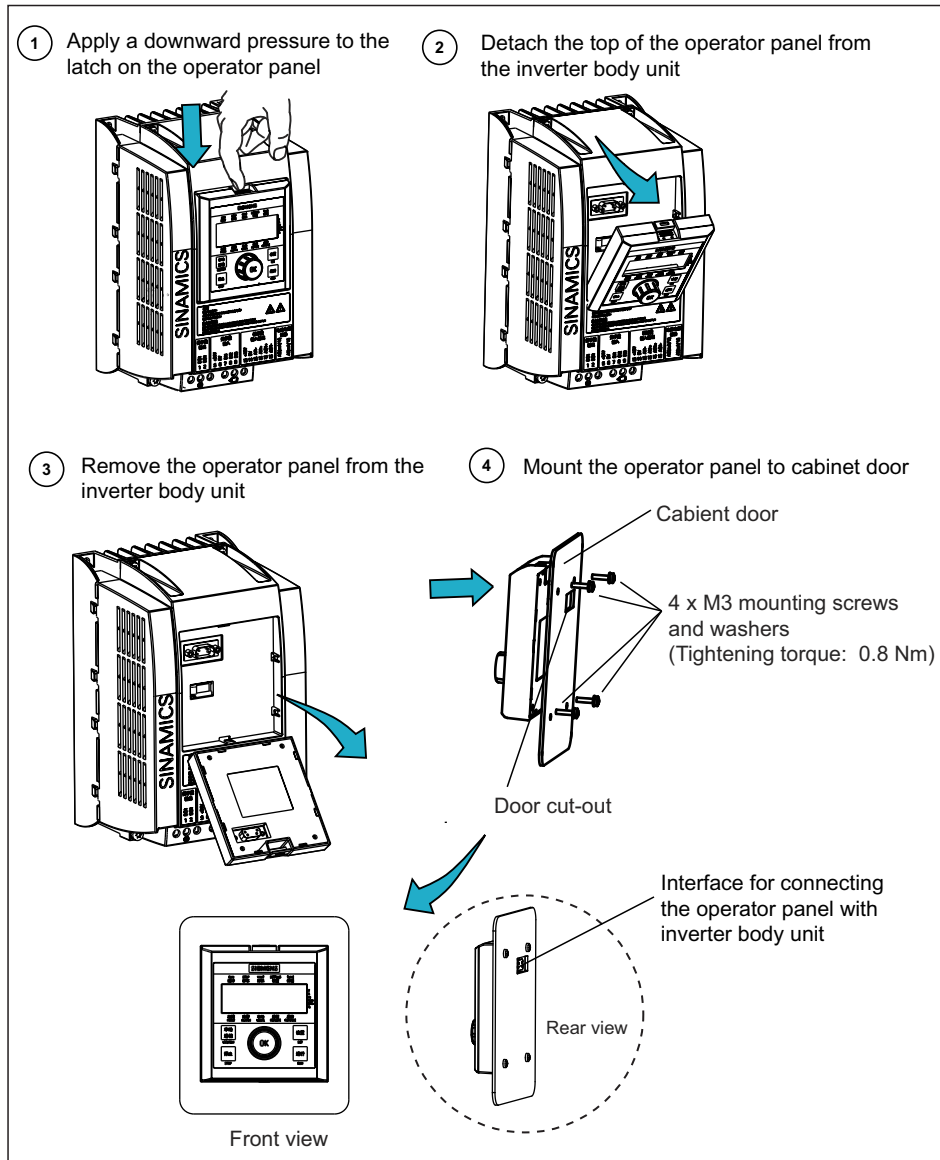

Figure 5-11 Procedure for mounting the operator panel to cabinet door

Note

For the cable connection between the operator panel and the inverter body unit, see topic "Interface definition (Page 33)".

5.2 Electrical installation

5.2.1 Interface definition

PE terminal layout

The position of PE terminals in Frame Size D is different from that in other frame sizes. See figure below for details.

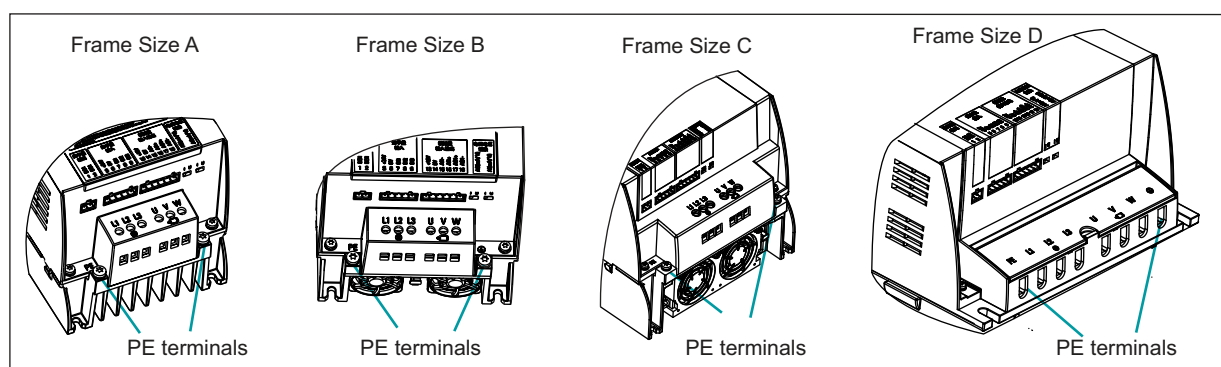

Figure 5-12 PE terminal layout

Table 5-5 Tightening torques for PE terminals

Inverter variant	Max. tightening torque for PE terminal (Nm)
Frame Size A	1.5
Frame Size B	1.5
Frame Size C	1.5
Frame Size D	2.5

Layout of interfaces other than PE terminals

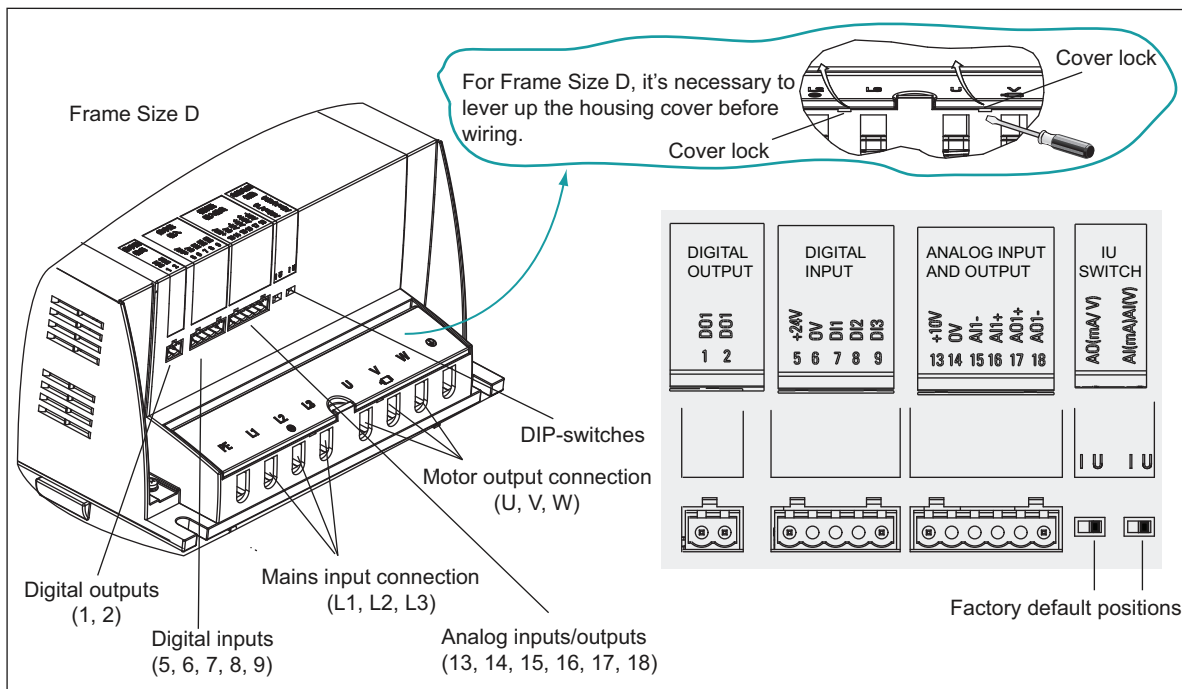

Figure 5-13 Layout of interfaces other than PE terminals (example)

Table 5-6 Tightening torques for motor output (U, V, W) and mains input terminals (L1, L2, L3)

Inverter variant	Max. tightening torque for motor output and mains input terminals (Nm)
Frame Size A	0.6
Frame Size B	0.6
Frame Size C	1.2
Frame Size D	2.5

NOTICE

Depending on your particular application, you can set both DIP-switches to required positions. Digital inputs and analog inputs/outputs provide the SELV voltages.

Interfaces between inverter body unit and the remote operator panel

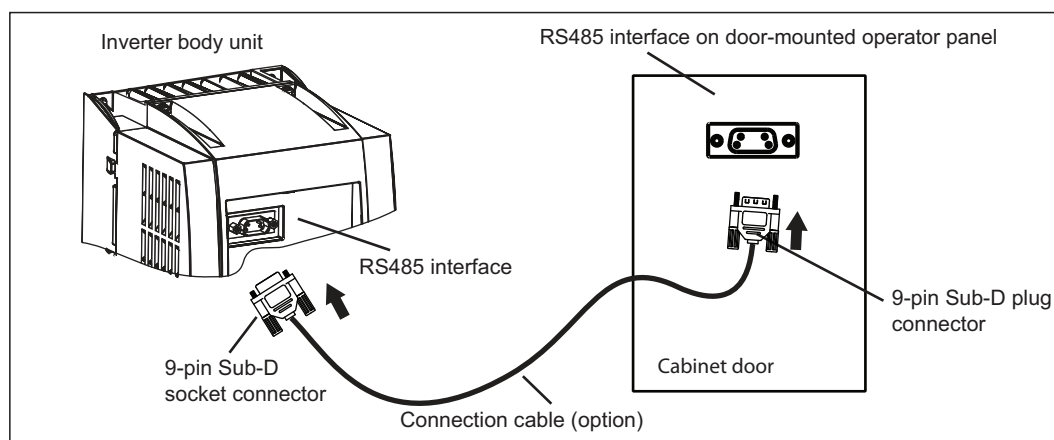

Figure 5-14 Interfaces between inverter body unit and the remote operator panel

NOTICE

RS485 interface provides the PELV voltage.

Conductor cross-sections of the mains input cable and the motor output cable

Table 5-7 Conductor cross-sections of the mains input cable and the motor output cable

Frame Size	Rated power (kW)	Conductor cross-section (mains input cable)				Conductor cross-section (motor output cable)			
		AWG		mm ²		AWG		mm ²	
Min.	Max.	Min.	Max.	Min.	Max.	Min.	Max.	Min.	Max.
A	0.55	1.0	1.5	17.0	15.0	1.0	1.5	17.0	15.0
	0.75	1.0	1.5	17.0	15.0	1.0	1.5	17.0	15.0
	1.1	1.0	1.5	17.0	15.0	1.0	1.5	17.0	15.0
	1.5	1.0	1.5	17.0	15.0	1.0	1.5	17.0	15.0
B	2.2	1.0	2.5	17.0	13.0	1.0	4.0	17.0	11.0
	3	1.0	2.5	17.0	13.0	1.0	4.0	17.0	11.0
	4	1.5	2.5	15.0	13.0	1.0	4.0	17.0	11.0
C	5.5	2.5	10.0	13.0	7.0	1.5	10.0	15.0	7.0
	7.5	4.0	10.0	11.0	7.0	2.5	10.0	13.0	7.0
	11	6.0	10.0	10.0	7.0	4.0	10.0	11.0	7.0
D	15	8.0	20.0	8.0	4.0	8.0	20.0	8.0	4.0
	18.5	10.0	20.0	7.0	4.0	8.0	20.0	8.0	4.0
	22	12.0	20.0	6.0	4.0	10.0	20.0	7.0	4.0

Note

Use 75 °C wire for an ambient temperature of 40 °C or less and use 90 °C wire for ambient temperature between 40 °C and 60 °C.

A correction factor of $K = 0.71$ has been used based on the following:

A maximum of four cables are laid side by side on a cable ladder.

The ambient temperature during cable operation is 30 °C.

(in accordance with EN 60204-1 and IEC 364-5-523)

Conductor cross-sections of the DI/DO, AI/AO terminal connecting cable

Table 5-8 Conductor cross-sections of the DI/DO, AI/AO terminal connecting cable

	DO (Digital Outputs)	DI (Digital inputs)	AI (Analog inputs)	AO (Analog outputs)
Limit value (mm ²)	≤ 1.2	≥ 0.1	≥ 0.1	≥ 0.1
Recommended value (mm ²)	1.0	0.25	0.25	0.25

NOTICE

To ensure that input/output precision is ≤ 1 %, it's recommended that the cable length be less than (<) 5 m. If you don't have this precision requirement, use a cable which is less than (<) 30 m.

5.2.2 Connecting power supply to the motor

Power and motor connections

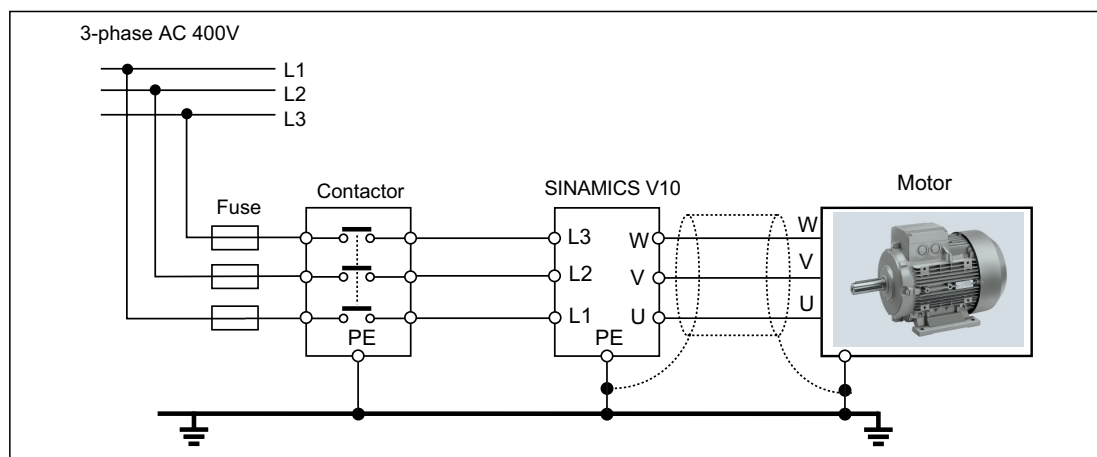

Figure 5-15 Power and motor connections

CAUTION

Ensure that the appropriate fuses with specified current ratings are connected between the power supply and the inverter (See table below for the type of recommended SIEMENS fuses for different frame sizes.). For detailed fuse specification, consult your local inverter distributor or visit the SIEMENS website concerned.

Table 5-9 Types of SIEMENS line fuses (recommended)

Inverter variant	Inverter output power rating (kW)	Fuse type	Fuse current rating (A)
Frame Size A	0.55	3NA3803	10
	0.75	3NA3803	10
	1.1	3NA3803	10
	1.5	3NA3803	10
Frame Size B	2.2	3NA3805	16
	3	3NA3805	16
	4	3NA3807	20
Frame Size C	5.5	3NA3807	20
	7.5	3NA3810	25
	11	3NA3814	35
Frame Size D	15	3NA3817	40
	18.5	3NA3820	50
	22	3NA3822	63

Commissioning

6.1 Typical connection modes

This chapter describes ten kinds of typical connection modes, from which the customer can select according to his own needs. When a connection macro is selected via the operator panel (for details, please refer to " **Operation mode ② - Connection macro selection** ") after the wiring work, relevant parameter settings will be done automatically, which greatly helps simplify the work of quick commissioning

WARNING

Direct contact between copper earthing conductor and aluminium PE terminal will lead to significant corrosion due to electrochemical action! Make sure that copper earthing conductor is corrosion resistant or properly plated.

The earth-leakage current exceeding 3.5 mA may occur during normal operation of the inverter. A permanently fixed ground connection must be provided.

CAUTION

The inverter digital input terminals, analog input/output terminals and the communication port between the inverter body unit and the operator panel should be double-insulated from live parts and meet the requirements for SELV (Safety Extra Low Voltage) in EN61800-5-1, and those terminals shall be connected to other SELV circuits.

The inverter output terminals (relay output, max. 250 V) are at a dangerously high voltage when Non-SELV control voltage is applied. Use only approved double insulated cable for supply connection with nominal cross-section area of at least 0.75 mm² / 300 V / 75 °C and protected by max. 6A external fuse, type gG approved based on IEC 60269.

NOTICE

To change the default lamp ON setting as indicated in figures below, go to P0748.

To calibrate the analog input setpoint in some typical connection modes mentioned below, go to P0753 to P0761.

To calibrate the analog output setpoint in some typical connection modes mentioned below, go to P0771 to P0781.

In addition to application macros, for each typical connection mode (except "Typical connection mode 1") as described below, still you can set some read-only or unlocked parameters as per your particular demands.

Some default parameter values depend on specific connection macro, inverter type, motor rating data, etc. You can find detailed description of these parameters in Chapter 7 Parameter List.

Function of DC Braking can be enabled through proper settings of P0703 and P1230.

In LOC mode, default frequency setpoint depends on P1040. For relative parameters, please refer to P1031 and P1040.

For parameters related to connection modes, please see table in Application macros (Page 56).

Typical connection mode 1 (C01) - Out-of-box application

Description:

1. Only input power and motor 3-phase connection
2. Motor start/stop, rotation direction and speed are controlled via the operator panel only.

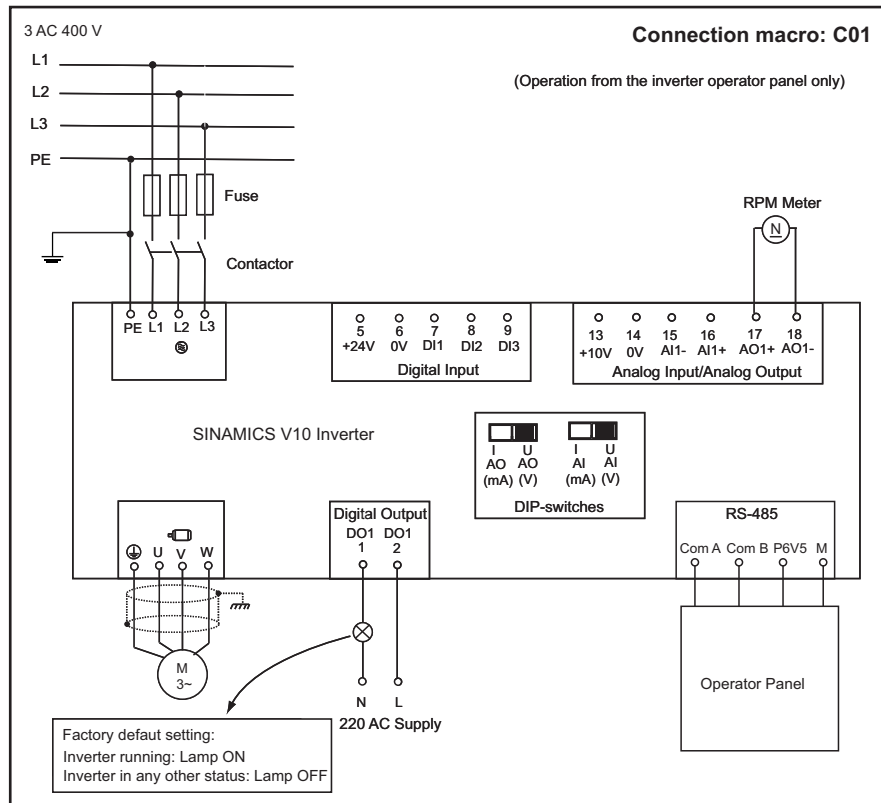

Figure 6-1 Typical connection mode 1 (C01)

The DIP-switch settings

DIP-switch (AO): Depends on external RPM Meter

DIP-switch (AI): The setting in this application is inactive

Table 6-1 Select connection macro C01 with the operator panel after the wiring (please refer to "Operation mode ② - Connection macro selection", and then below parameter settings will be automatically finished.)

Par. No.	Parameter name	Range	Unit	Default
r0007	Selected connection macro and application macro	C0100 - C1105	--	C01xx*
P0610	Motor I ² t reaction	0 - 2	--	1
P0701	Function of digital input 1	0 - 99	--	0
P0702	Function of digital input 2	0 - 99	--	0
P0703	Function of digital input 3	0 - 99	--	0

6.1 Typical connection modes

Par. No.	Parameter name	Range	Unit	Default
P1000	Selection of frequency setpoint	0 - 53	--	5
P0725	PNP/NPN digital inputs	0 - 1	--	1

* "xx" means current application macro.

Typical connection mode 2 (C02)

Description:

1. In LOC mode, motor start/stop, rotation direction and speed can be controlled via the operator panel.
2. In REM mode, motor start/stop can be controlled via an external signal source connected to DI3, MOP-up (for increasing motor frequency)/MOP-down (for decreasing motor frequency) via external signal sources connected to DI1 and DI2.

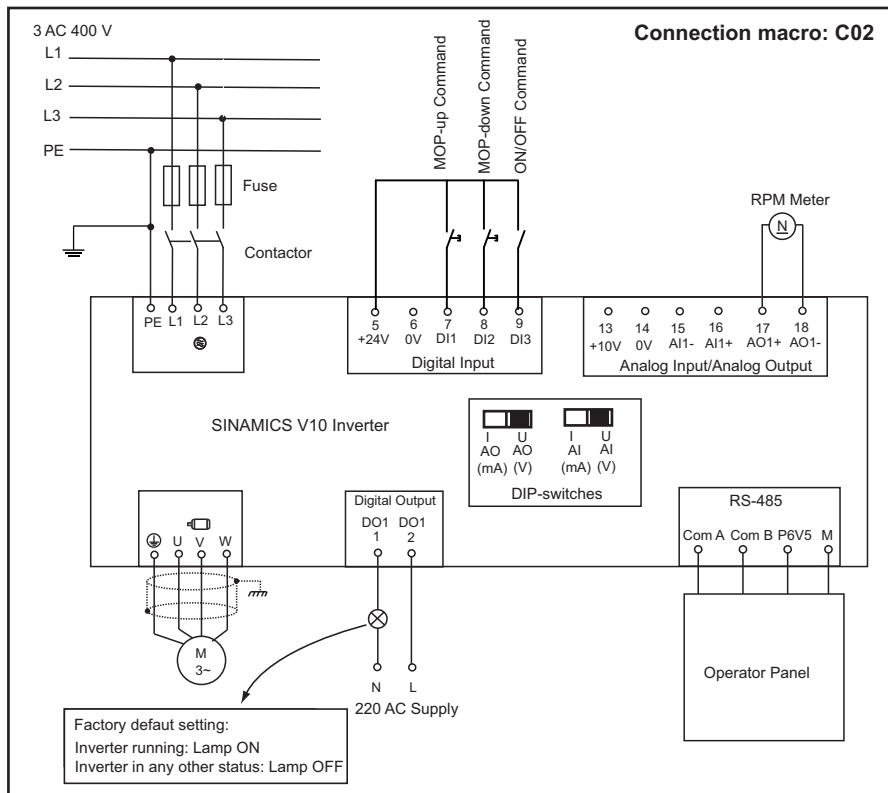

Figure 6-2 Typical connection mode 2 (C02)

The DIP-switch settings

DIP-switch (AO): Depends on external RPM Meter

DIP-switch (AI): The setting in this application is inactive

Table 6-2 Select connection macro C02 with the operator panel after the wiring (please refer to "Operation mode ② - Connection macro selection", and then below parameter settings will be automatically finished.)

Par. No.	Parameter name	Range	Unit	Default
r0007	Selected connection macro and application macro	C0100 - C1105	--	C02xx*
P0610	Motor I ² t reaction	0 - 2	--	2
P0701	Function of digital input 1	0 - 99	--	13
P0702	Function of digital input 2	0 - 99	--	14
P0703	Function of digital input 3	0 - 99	--	1
P1000	Selection of frequency setpoint	0 - 53	--	1
P0725	PNP/NPN digital inputs	0 - 1	--	1

* "xx" means current application macro.

Typical connection mode 3 (C03)

Description:

1. In LOC mode, motor start/stop, rotation direction and speed can be controlled via the operator panel.
2. In REM mode, motor start/stop can be controlled via an external signal source connected to DI1, motor speed via an external potentiometer.

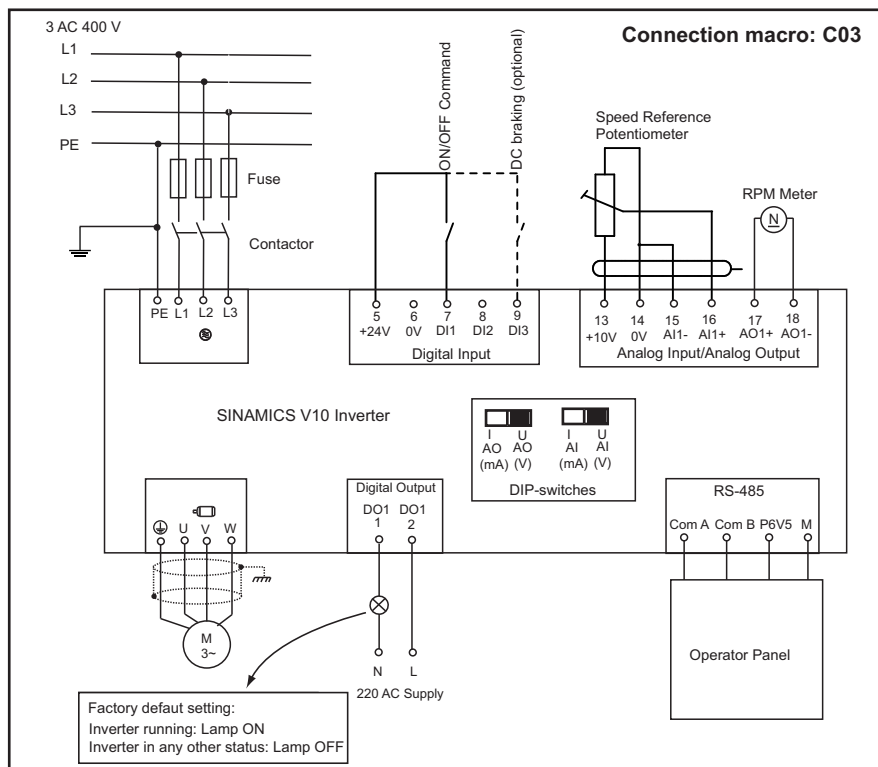

Figure 6-3 Typical connection mode 3 (C03)

The DIP-switch settings

6.1 Typical connection modes

DIP-switch (AO): Depends on external RPM Meter

DIP-switch (AI): Must be set to voltage (V) mode

Table 6-3 Select connection macro C03 with the operator panel after the wiring (please refer to "Operation mode ② - Connection macro selection", and then below parameter settings will be automatically finished.)

Par. No.	Parameter name	Range	Unit	Default
r0007	Selected connection macro and application macro	C0100 - C1105	--	C03xx*
P0610	Motor I ² t reaction	0 - 2	--	2
P0701	Function of digital input 1	0 - 99	--	1
P0702	Function of digital input 2	0 - 99	--	0
P0703	Function of digital input 3	0 - 99	--	0
P1000	Selection of frequency setpoint	0 - 53	--	2
P0725	PNP/NPN digital inputs	0 - 1	--	1

* "xx" means current application macro.

Typical connection mode 4 (C04)

Description:

1. In LOC mode, motor start/stop, rotation direction and speed can be controlled via the operator panel.
2. In REM mode, motor start/stop can be controlled via an external signal source connected to DI1, motor speed via an external potentiometer and motor rotation direction via an external signal source connected to DI2.

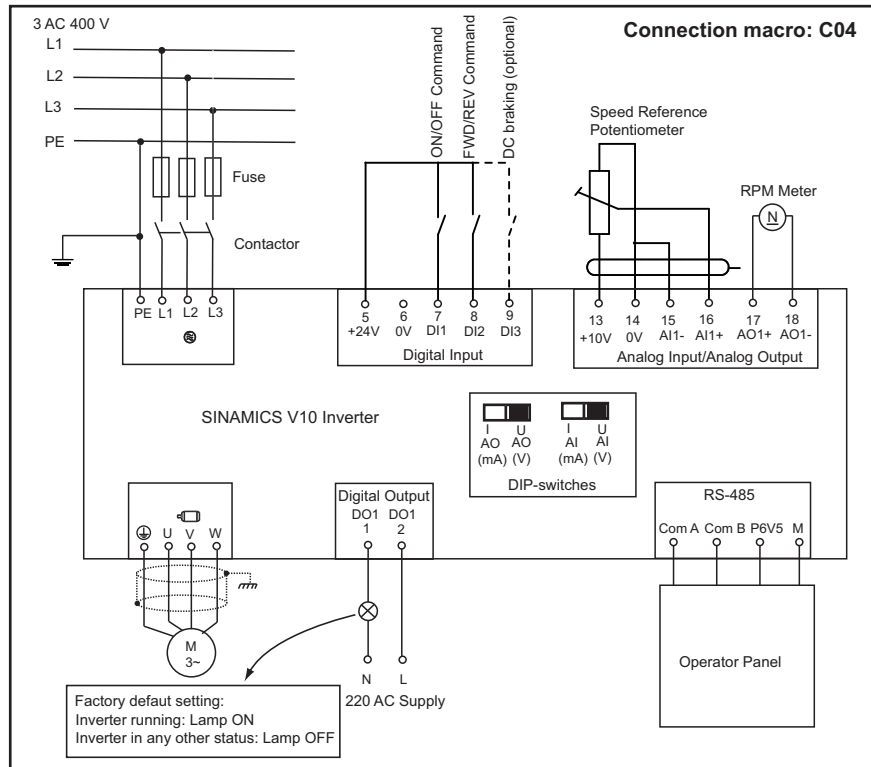

Figure 6-4 Typical connection mode 4 (C04)

The DIP-switch settings

DIP-switch (AO): Depends on external RPM Meter

DIP-switch (AI): Must be set to voltage (V) mode

Table 6-4 Select connection macro C04 with the operator panel after the wiring (please refer to "Operation mode ② - Connection macro selection", and then below parameter settings will be automatically finished.)

Par. No.	Parameter name	Range	Unit	Default
r0007	Selected connection macro and application macro	C0100 - C1105	--	C04xx*
P0610	Motor I ² t reaction	0 - 2	--	2
P0701	Function of digital input 1	0 - 99	--	1
P0702	Function of digital input 2	0 - 99	--	12
P0703	Function of digital input 3	0 - 99	--	0

6.1 Typical connection modes

Par. No.	Parameter name	Range	Unit	Default
P1000	Selection of frequency setpoint	0 - 53	--	2
P0725	PNP/NPN digital inputs	0 - 1	--	1

* "xx" means current application macro.

Typical connection mode 5 (C05)

Description:

1. In LOC mode, motor start/stop, rotation direction and speed can be controlled via the operator panel.
2. In REM mode, motor start/stop can be controlled via an external signal source connected to DI2, motor speed via an external potentiometer.
3. LOC and REM mode switch-over is controlled via an external signal source connected to DI1.

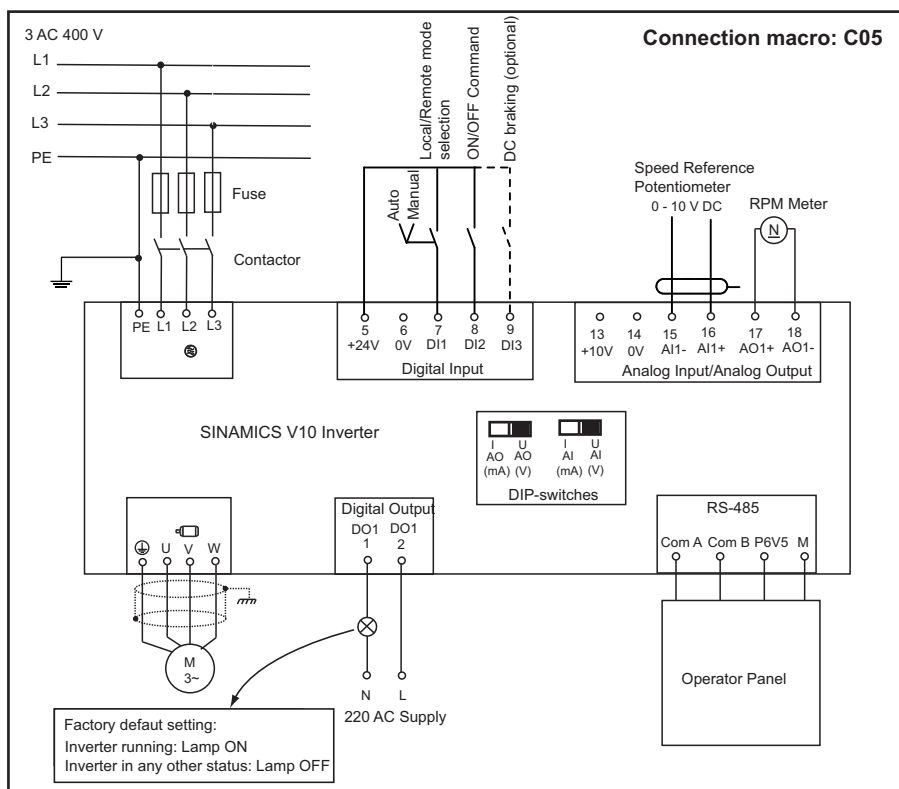

Figure 6-5 Typical connection mode 5 (C05)

The DIP-switch settings in this application

DIP-switch (AO): Depends on external RPM Meter

DIP-switch (AI): Must be set to voltage (V) mode

Table 6-5 Select connection macro C05 with the operator panel after the wiring (please refer to "Operation mode ② - Connection macro selection", and then below parameter settings will be automatically finished.)

Par. No.	Parameter name	Range	Unit	Default
r0007	Selected connection macro and application macro	C0100 - C1105	--	C05xx*
P0610	Motor I ² t reaction	0 - 2	--	1
P0701	Function of digital input 1	0 - 99	--	99
P0702	Function of digital input 2	0 - 99	--	1
P0703	Function of digital input 3	0 - 99	--	0
P1000	Selection of frequency setpoint	0 - 53	--	2
P0725	PNP/NPN digital inputs	0 - 1	--	1

* "xx" means current application macro.

Typical connection mode 6 (C06)

Description:

1. In LOC mode, motor start/stop, rotation direction and speed can be controlled via the operator panel.
2. In REM mode, motor start/stop can be controlled via an external signal source connected to DI1, motor set frequency via external signal sources connected to DI2 and DI3. When DI2 is selected, you can change the motor set frequency with P1002 in the "Operation mode ⑤ - Access all the parameters (Page 71)" mode. When DI3 is selected, you can change the motor set frequency with P1003 in the "Operation mode ⑤ - Access all the parameters (Page 71)" mode. If both DI2 and DI3 are selected, the motor set frequency is the sum of the value of P1002 and the value of P1003.

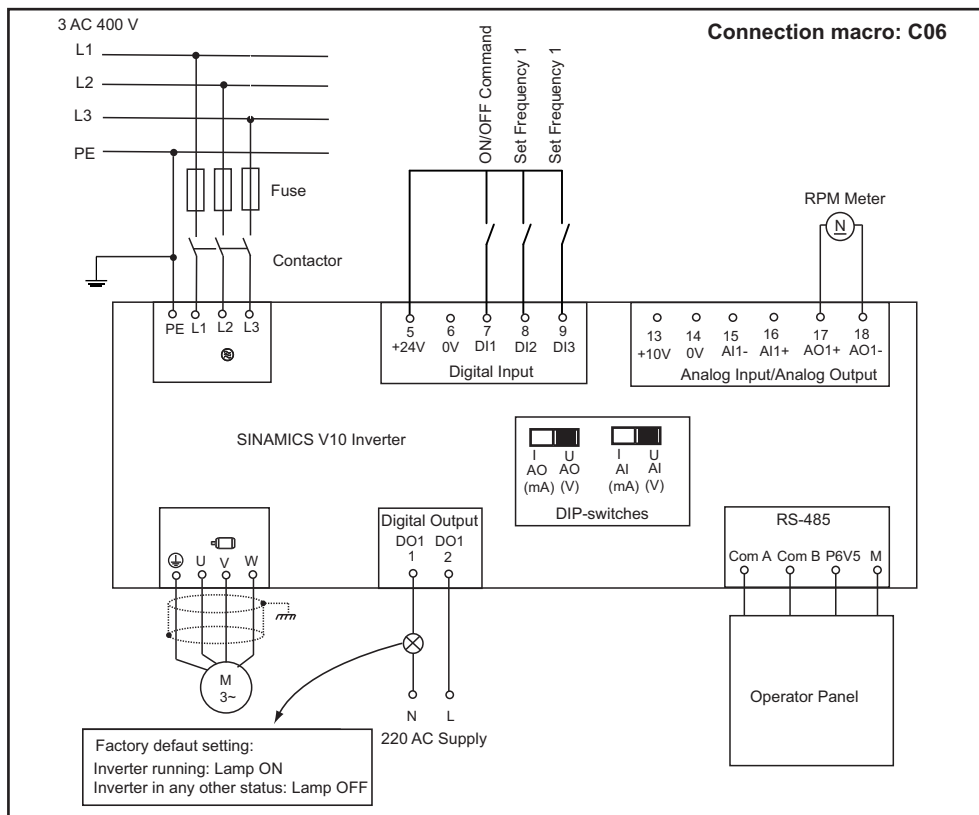

Figure 6-6 Typical connection mode 6 (C06)

The DIP-switch settings

DIP-switch (AO): Depends on external RPM Meter

DIP-switch (AI): The DIP-switch setting in this application is inactive.

Table 6-6 Select connection macro C06 with the operator panel after the wiring (please refer to "Operation mode ② - Connection macro selection", and then below parameter settings will be automatically finished.)

Par. No.	Parameter name	Range	Unit	Default
r0007	Selected connection macro and application macro	C0100 - C1105	--	C06xx*
P0610	Motor I ² t reaction	0 - 2	--	2
P0701	Function of digital input 1	0 - 99	--	1
P0702	Function of digital input 2	0 - 99	--	15
P0703	Function of digital input 3	0 - 99	--	15
P1000	Selection of frequency setpoint	0 - 53	--	3
P0725	PNP/NPN digital inputs	0 - 1	--	1

* "xx" means current application macro.

Typical connection mode 7 (C07)

Description:

1. In LOC mode, motor start/stop, rotation direction and speed can be controlled via the operator panel.
2. In REM mode, motor start/stop and rotation direction can be controlled via an external PLC (PNP type) connected to DI1 and DI2, motor speed via an external signal source.

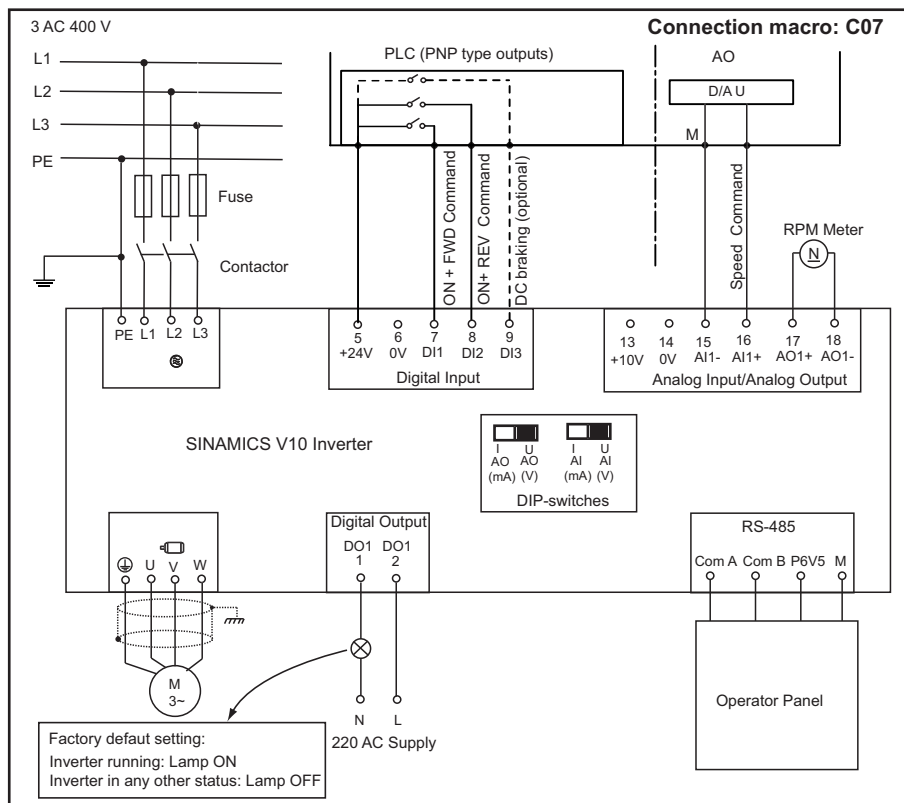

Figure 6-7 Typical connection mode 7 (C07)

The DIP-switch settings

6.1 Typical connection modes

DIP-switch (AO): Depends on the external signal source

DIP-switch (AI): Depends on the external signal source

Table 6-7 Select connection macro C07 with the operator panel after the wiring (please refer to "Operation mode ② - Connection macro selection", and then below parameter settings will be automatically finished.)

Par. No.	Parameter name	Range	Unit	Default
r0007	Selected connection macro and application macro	C0100 - C1105	--	C07xx*
P0610	Motor I ² t reaction	0 - 2	--	2
P0701	Function of digital input 1	0 - 99	--	13
P0702	Function of digital input 2	0 - 99	--	2
P0703	Function of digital input 3	0 - 99	--	0
P1000	Selection of frequency setpoint	0 - 53	--	2
P0725	PNP/NPN digital inputs	0 - 1	--	1

* "xx" means current application macro.

Typical connection mode 8 (C08)

Description:

1. In LOC mode, motor start/stop, rotation direction and speed can be controlled via the operator panel.
2. In REM mode, motor start/stop and rotation direction can be controlled via an external PLC (NPN type) connected to DI1 and DI2, motor speed via an external signal source.

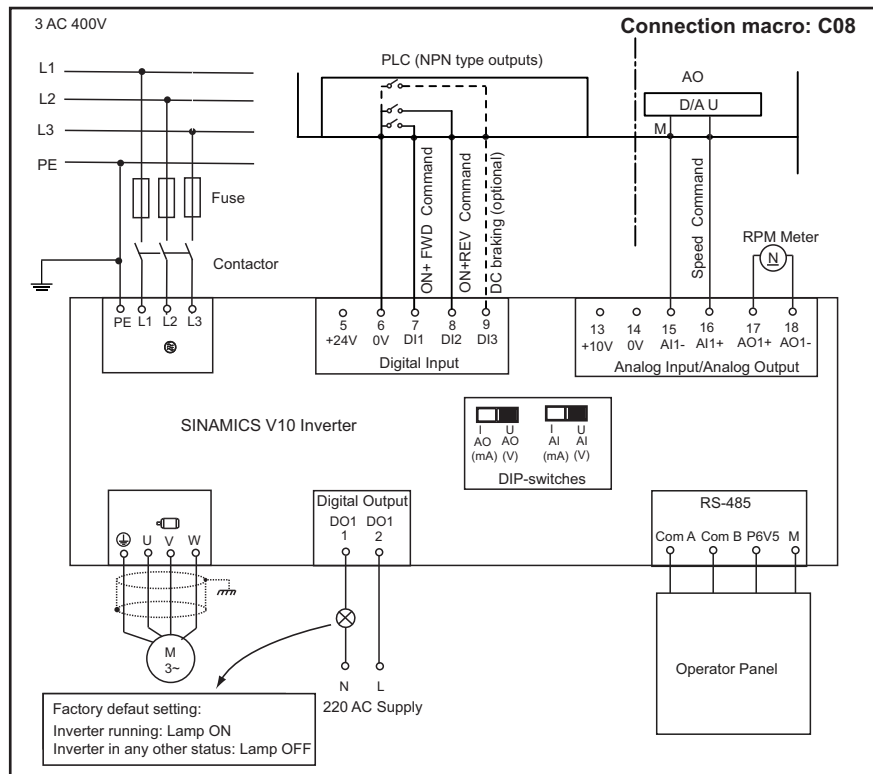

Figure 6-8 Typical connection mode 8 (C08)

The DIP-switch settings

DIP-switch (AO): Depends on the external signal source

DIP-switch (AI): Depends on the external signal source

Table 6-8 Select connection macro C08 with the operator panel after the wiring (please refer to "Operation mode ② - Connection macro selection", and then below parameter settings will be automatically finished.)

Par. No.	Parameter name	Range	Unit	Default
r0007	Selected connection macro and application macro	C0100 - C1105	--	C08xx*
P0610	Motor I ² t reaction	0 - 2	--	2
P0701	Function of digital input 1	0 - 99	--	1
P0702	Function of digital input 2	0 - 99	--	2
P0703	Function of digital input 3	0 - 99	--	0
P1000	Selection of frequency setpoint	0 - 53	--	2
P0725	PNP/NPN digital inputs	0 - 1	--	0

6.1 Typical connection modes

* "xx" means current application macro.

Typical connection mode 9 (C09)

Description:

1. In LOC mode, motor start/stop, rotation direction and speed can be controlled via the operator panel.
2. In REM mode, motor start/stop can be controlled via an external signal source connected to DI1, motor speed via an external potentiometer, motor rotation in JOG mode via external signal sources connected to DI2 and DI3.

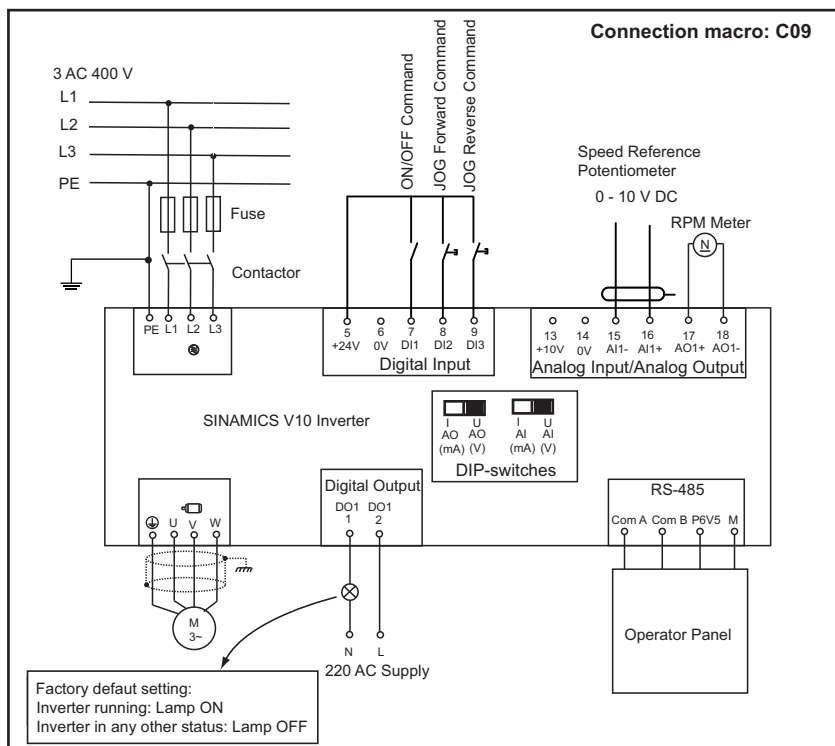

Figure 6-9 Typical connection mode 9 (C09)

The DIP-switch settings

DIP-switch (AO): Depends on external RPM Meter

DIP-switch (AI): Must be set to voltage (V) mode

Table 6-9 Select connection macro C09 with the operator panel after the wiring (please refer to "Operation mode ② - Connection macro selection", and then below parameter settings will be automatically finished.)

Par. No.	Parameter name	Range	Unit	Default
r0007	Selected connection macro and application macro	C0100 - C1105	--	C09xx*
P0610	Motor I ² t reaction	0 - 2	--	2
P0701	Function of digital input 1	0 - 99	--	1
P0702	Function of digital input 2	0 - 99	--	10

Par. No.	Parameter name	Range	Unit	Default
P0703	Function of digital input 3	0 - 99	--	11
P1000	Selection of frequency setpoint	0 - 53	--	2
P0725	PNP/NPN digital inputs	0 - 1	--	1

* "xx" means current application macro.

Typical connection mode 10 (C10)

Description:

1. In LOC mode, motor start/stop, rotation direction and speed can be controlled via the operator panel.
2. In REM mode, motor start/stop can be controlled via an external signal source connected to DI1, motor MOP-up/MOP-down via external signal sources connected to DI2 and DI3, feedback value via an external sensor connected to terminals AI1+ and AI1-.

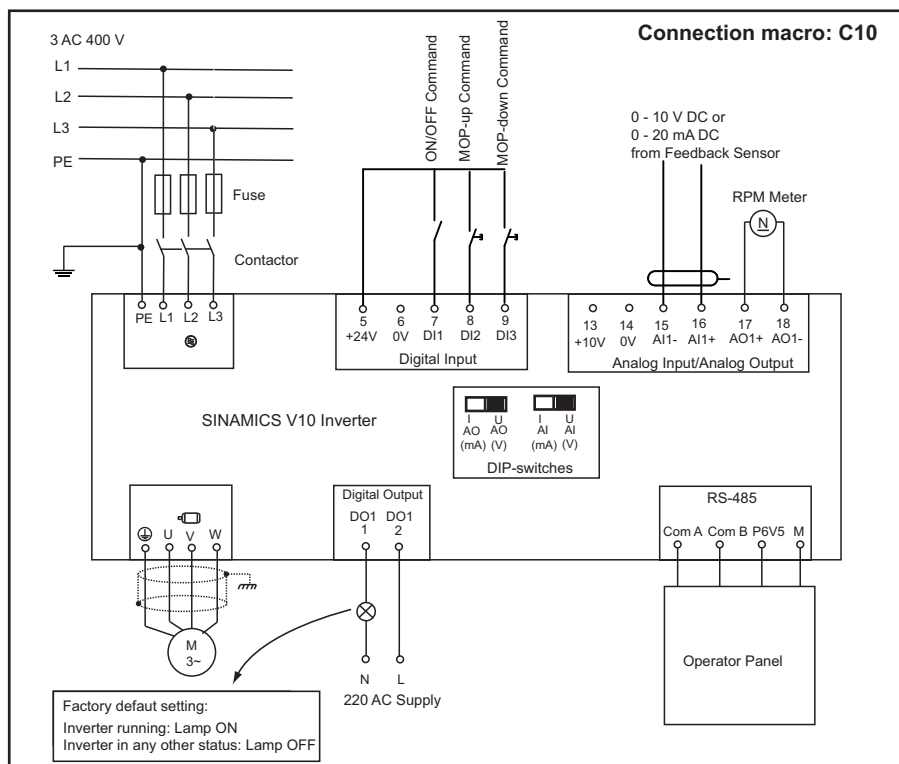

Figure 6-10 Typical connection mode 10 (C10)

The DIP-switch settings in this application

DIP-switch (AO): Depends on the external signal source

DIP-switch (AI): Depends on the external signal source

6.1 Typical connection modes

Table 6-10 Select connection macro C10 with the operator panel after the wiring (please refer to "Operation mode ② - Connection macro selection", and then below parameter settings will be automatically finished.)

Par. No.	Parameter name	Range	Unit	Default
r0007	Selected connection macro and application macro	C0100 - C1105	--	C10xx*
P0610	Motor I ² t reaction	0 - 2	--	2
P0701	Function of digital input 1	0 - 99	--	1
P0702	Function of digital input 2	0 - 99	--	13
P0703	Function of digital input 3	0 - 99	--	14
P1000	Selection of frequency setpoint	0 - 53	--	1
P0725	PNP/NPN digital inputs	0 - 1	--	1

* "xx" means current application macro.

NOTICE
<p>The PI controller function is valid only in this connection mode and when the current control mode is set to REM mode.</p> <p>In this connection mode, PI setpoint must be set via P2240 and feedback value shall, depending on actually connected sensor, be scaled via P0753 to P0761.</p> <p>Besides parameters listed in Auto hotspot , P2280 (default value: 0.500), P2285 (default value: 10.000s) and P2293 (default value: 10.00s) are also related to connection mode.</p>

Typical connection mode 11 (C11)

Description:

1. Motor start/stop and rotation direction can be controlled via DI1 and DI2, motor speed via the operator panel.

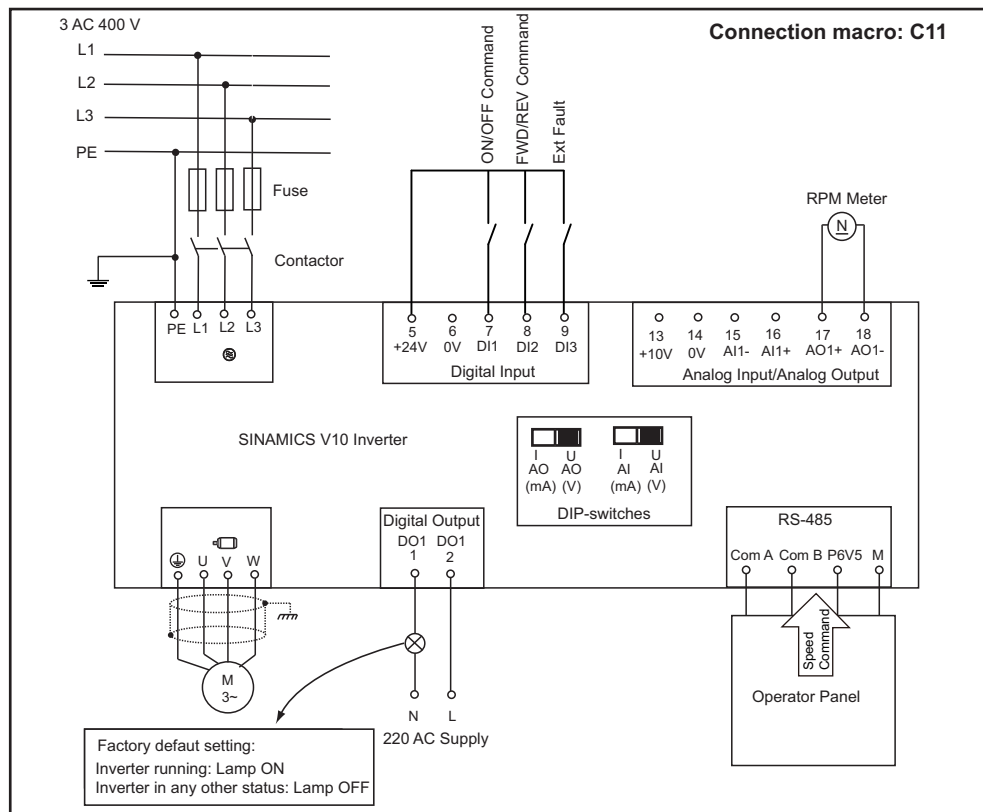

Figure 6-11 Typical connection mode 11 (C11)

The DIP-switch settings

DIP-switch (AO): Depends on external RPM Meter

DIP-switch (AI): The setting in this application is inactive

Table 6-11 Select connection macro C10 with the operator panel after the wiring (please refer to "Operation mode ② - Connection macro selection", and then below parameter settings will be automatically finished.)

Par. No.	Parameter name	Range	Unit	Default
r0007	Selected connection macro and application macro	C0100 - C1105	--	C10xx*
P0610	Motor I ² t reaction	0 - 2	--	2
P0701	Function of digital input 1	0 - 99	--	1
P0702	Function of digital input 2	0 - 99	--	12
P0703	Function of digital input 3	0 - 99	--	9
P1000	Selection of frequency setpoint	0 - 53	--	5

* "xx" means current application macro.

See also

Application macros (Page 56)

6.2 Application macros

Application macros

This chapter describes six application macros available:

Table 6-12 Descriptions to application macro

Application macro	Name	Description	Typical load
A00 ¹⁾	Out of box	-	-
A01	Simple fan/pump with light starting load	Varying load with low starting torque	Simple fan/pump
A02	Heavy pump with heavy starting load	Pumping load with high starting torque	Sewage pump, mud pump, screw pump, gear pump, etc.
A03	Conveyor load	Applications which require smooth speed-transition	Conveyor
A04	High inertia load	Load inertia is relatively high, which requires slow starting/stopping	Centrifuge, roller, industry washer, etc.
A05	High torque load with heavy dead load	Starting torque of common constant-torque machine is relatively high, which requires slow starting/stopping	Extruder, injection molding machine, stirring mill

¹⁾ A00 - Out of box is the default application macro, i.e. the application macro will be reset to A00 when a new connection macro is selected.

Parameters related to application macros

Par. No.	Name	Range	Unit	Default value					
				A00	A01	A02	A03	A04	A05
P1120	Ramp-up time	0.00 - 300.00	s	10.00	20.00	20.00	10.00	90.00	20.00
P1121	Ramp-down time	0.00 - 300.00	s	10.00	20.00	20.00	10.00	120.00	20.00
P1130	Ramp-up initial rounding time	0.00 - 40.00	s	0.00	0.00	0.00	0.00	0.00	0.00
P1131	Ramp-up final rounding time	0.00 - 40.00	s	0.00	0.00	0.00	0.00	0.00	0.00
P1132	Ramp-down initial rounding time	0.00 - 40.00	s	0.00	0.00	0.00	0.00	0.00	0.00

Par. No.	Name	Range	Unit	Default value					
P1133	Ramp-down final rounding time	0.00 - 40.00	s	0.00	0.00	0.00	0.00	0.00	0.00
P1080	Min. frequency	0.00 - 300.00	Hz	0.00	20.00	0.00	0.00	5.00	0.00
P1082	Max. frequency	0.00 - 300.00	Hz	50.00	50.00	50.00	50.00	50.00	50.00
P1300	Control mode	0 - 2	--	0	2	0	0	0	0
P1310	Continuous boost	0.0 - 250.0	%	50.0	0.0	50.0	0.0	50.0	50.0
P1311	Acceleration boost	0.0 - 250.0	%	0.0	0.0	0.0	50.0	0.0	0.0
P1312	Starting boost	0.0 - 250.0	%	0.0	0.0	0.0	0.0	0.0	0.0
P1240	Configuration of Vdc controller	0 - 1	--	1	1	1	1	1	1
P1243	Dynamic factor of Vdc-max	10 - 200	%	100	100	100	100	100	100
P1230	Enable DC braking	0:0 - 4,000:0	--	0:0	0:0	0:0	0:0	0:0	0:0
P1232	DC braking current	0 - 250	%	0	0	0	0	0	0
P1233	Duration of DC braking	0 - 250	s	0	0	0	0	0	0
P1200	Flying start	0 - 6	--	0	1	0	0	0	0
P1202	Motor-current: Flying start	10 - 200	%	100	100	100	100	100	100
P1203	Search rate: Flying start	10 - 200	%	100	100	100	100	100	100
P1210	Automatic restart	0 - 6	--	1	2	1	1	1	1
P0640	Motor overload factor [%]	10.0 - 400.0	%	150.0	150.0	150.0	150.0	150.0	150.0
P1110	Inhibit negative setpoint	0.0 - 2036.F	--	0	1	1	0	0	0

6.3 Operator panel overview

Overview of the operator panel

The operator panel allows you to:

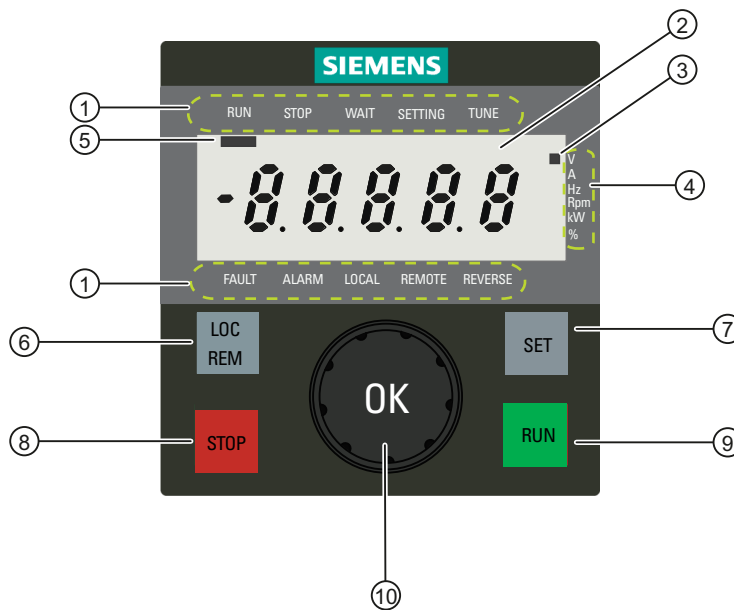





Figure 6-12 Operator panel overview



- Monitor motor status
- Control motor operation (Start/stop, speed, clockwise / counterclockwise rotation, etc.)
- View and acknowledge faults or alarms
- Set and modify parameters
- Switch over between "LOC" and "REM" controls

6.3.1 Function overview of operator panel

Table 6-13 Operator panel overview

Legend	Meaning	Function
①	Inverter status labels 	<p>RUN: Inverter is running</p> <p>STOP: Inverter stops operation</p> <p>WAIT: Inverter is ready for operation</p> <p>SETTING: The current frequency value shown is the frequency setpoint; inverter is confirming the selected connection macro or application macro.</p> <p>TUNE: Parameter value editing is allowed</p> <p>FAULT: Inverter is at fault</p> <p>ALARM: Inverter alarms</p> <p>LOCAL: Command source is from the operator panel</p> <p>REMOTE: Command source is from external terminal</p> <p>REVERSE: Motor is running in a reverse direction</p>
②	5-digit, 7-segment LCD	-
③	Parameter data unit indicator	Used to indicate the data unit of a specific parameter value.
④	Parameter data units	V: Voltage; A: Ampere; Hz: Hertz; Rpm: Revolutions per minute; kW: Kilowatt; %: percentage
⑤	Inverter status indicator	Used to indicate current inverter status.
⑥	LOC/REM (Local/Remote) key 	Switch between local and remote control modes ¹⁾ <p>LOC: Motor operation is controlled from the operator panel</p> <p>REM: Motor operation is controlled from an external signal source</p>
⑦	SET key 	<p>Long-press SET till the next operation mode appears:</p> <p>Change-over between the following operation modes (See section "Quick commissioning (Page 63)" for details):</p> <ol style="list-style-type: none"> 1. Quick motor data setting → Inverter status display 2. Connection macro selection → Inverter status display 3. Application macro selection → Inverter status display 4. Inverter status display → Access all the parameters 5. Access all the parameters → Inverter status display <p>Short-press SET:</p> <p>Change-over between the following operation modes (Points 1-4 below; See section "Quick commissioning (Page 63)" for details):</p> <ol style="list-style-type: none"> 1. Motor data setting → Connection macro selection 2. Connection macro selection → Application macro selection 3. Access all the parameters → Inverter status display 4. Common application macro specific parameter setting → Inverter status display 5. Move among digits of a specific settable value 6. Clear the fault code displayed

6.3 Operator panel overview

Legend	Meaning	Function
⑧	STOP key 	Press STOP < 2 s: Motor ramp-down (OFF1) ²⁾ Press STOP > 2 s: Motor to coast to a standstill (OFF2) ³⁾
⑨	RUN key 	Pressing RUN starts motor.
⑩	OK button 	<p>Press OK:</p> <ol style="list-style-type: none"> 1. Acknowledge fault 2. Loop through motor status data display 3. Confirm the selected connection macro or application macro 4. Go from a parameter number into its value setting or into its parameters index no. and back <hr/> <p>Turn OK clockwise:</p> <ol style="list-style-type: none"> 1. Go into the next parameter no., connection macro or application macro. 2. Accelerate the motor 3. Increase the setpoint <hr/> <p>Turn OK counterclockwise:</p> <ol style="list-style-type: none"> 1. Go into the last parameter no., connection macro or application macro. 2. Decelerate the motor 3. Decrease the setpoint



¹⁾ The factory default control mode is "LOC". In most cases, "LOC" is used for debugging purpose only.





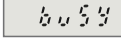
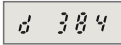
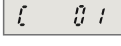
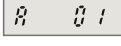

²⁾ For the description of OFF1 function, see "Notes on OFF functions" in Chapter 7.

³⁾ For the description of OFF2 function, see "Notes on OFF functions" in Chapter 7.

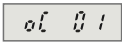
6.3.2 Various data displays

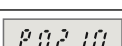
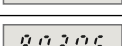
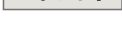
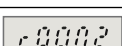
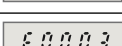
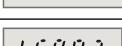
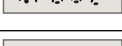
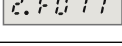
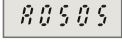
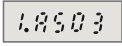
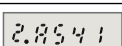
Table 6-14 Various data displays

Display	Example	Meaning	Remarks
-8.8.8.8.8		Inverter display is lighted	-
-----		Inverter initializing	-
busy		Inverter is confirming the selected connection macro or application macro, or inverter is busy	-
d xxx		Actual DC-link voltage	-
C xx		Connection macro available for selection	There are 10 connection macros available for selection: C01 ... C11.
A xx		Application macro available for selection	There are 6 application macros available for selection : A00 ... A05

Display	Example	Meaning	Remarks
oCxx		Selected connection macro	-
oAxx		Selected application macro	-
Cxxxx		Selected connection macro and application macro	As described in the example, "01" represents "C01", while "00" represents "A00".
Pxxxx		Parameter no. (Settable parameter)	
P.xxxx		Parameter no. (Settable parameter)	This kind of parameters with a dot is only available in quick motor data setting mode. (For details, see "Notice" in Section 6.2.2.3)
rxxxx		Parameter no. (Read-only parameter)	
Fxxxx		Fault code (in case of a single fault)	
x.Fxxx		Fault code of the 1st fault (in case of multiple faults)	The inverter can display up to 4 recently occurred faults in turn.
		Fault code of the 2nd fault (in case of multiple faults)	
Axxxx		Alarm code (in case of a single alarm)	
x.Axxx		Alarm code of the 1st alarm (in case of multiple alarms)	The inverter can display up to 4 recently occurred alarms in turn.
		Alarm code of the 2nd alarm (in case of multiple alarms)	
Err -		Value setting impossible	
----- -----		Error parameter editing	It's a warning indicating that what you're trying to edit is a read-only parameter and such editing is not allowed.
xxx. xx		Parameter value, positive	Display a positive value of 5 digits at most.
-xxx.xx		Parameter value, negative	Display a negative value of 5 digits at most.
inxxx		Indexed parameter	The figure after "in" indicates the number of indices. For example, "In013" means that this indexed parameter has 13 indices.
bxxxx	See figure below	Binary parameter	Meaning of each segment bit is described in individual parameters concerned.

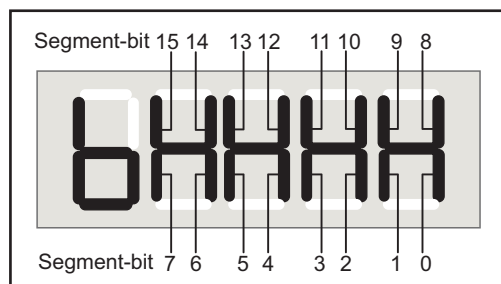

Figure 6-13 Binary parameter display

6.3.3 Displays during inverter initialization stage

Displays during inverter initialization stage

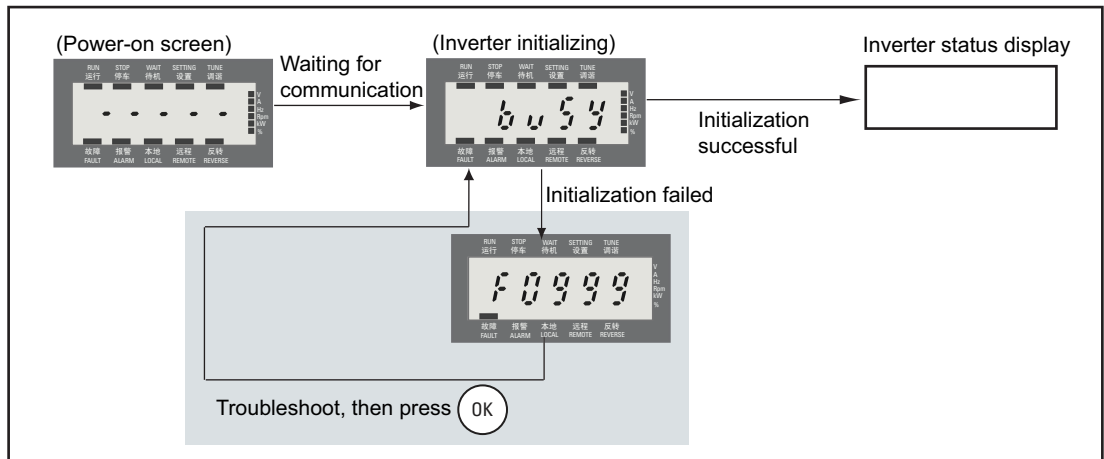

Figure 6-14 Displays during inverter initialization stage

6.4 Quick commissioning

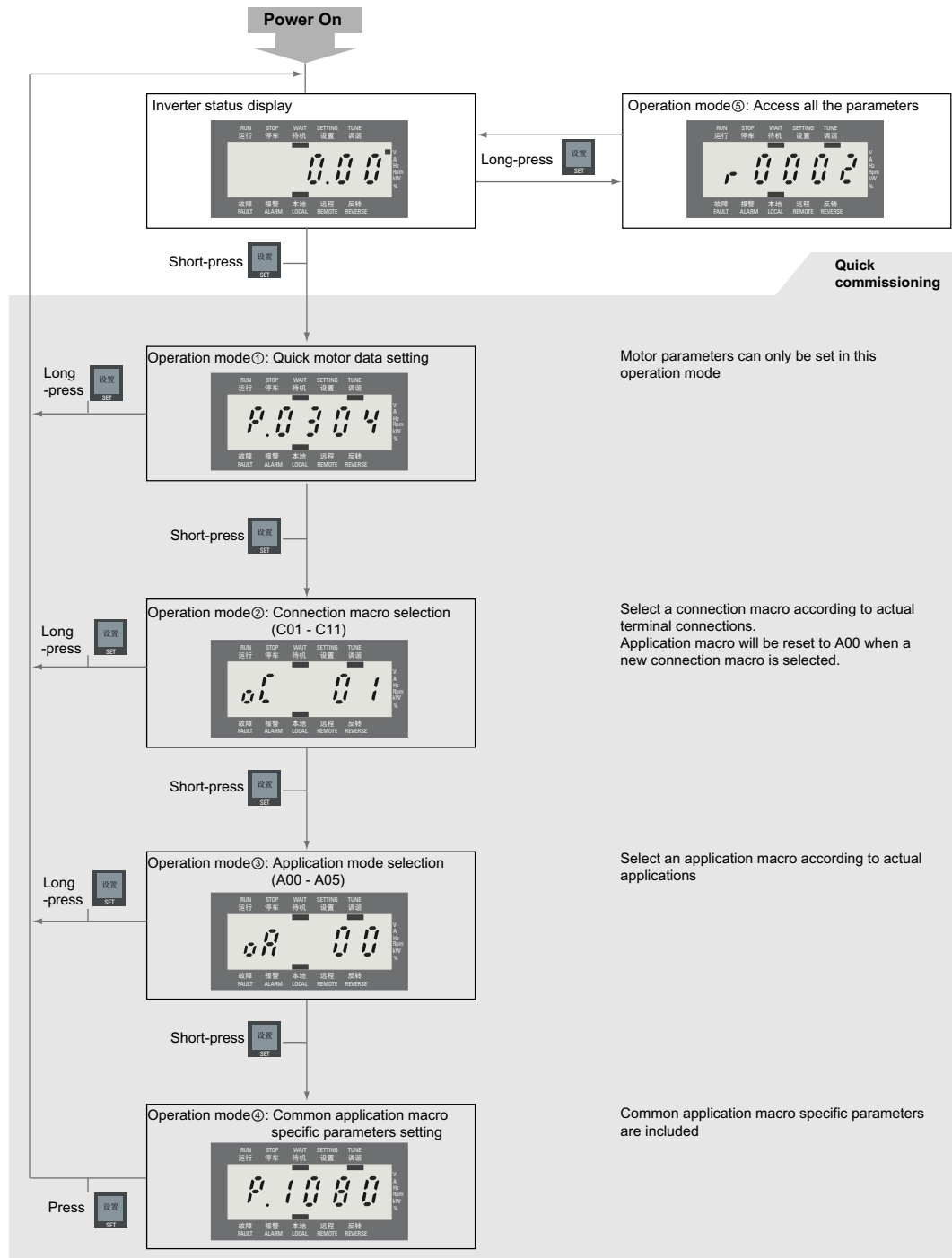

Figure 6-15 Commissioning flowchart

NOTICE

"P" of parameters in quick commissioning is followed by a ".", for example, P.0304 and P.1080.

Motor parameters can only be set in "Operation mode ① - Quick motor data setting (Page 66)", but in "Operation mode ⑤ - Access all the parameters", all the motor parameters except for P0305 are read-only.

Motor data

In SINAMICS V10, the factory default motor parameter values are set based on SIEMENS 1LG0 4-pole AC motors. (See table below for default motor data settings of SIEMENS 1LG0 4-pole AC motors.) You can change the defaults against data shown on the rating plate of your motor connected.

SIEMENS 1LG0 4-pole AC motors							
Rated inverter output power (kW)	Motor frame size	Motor Type	Rated speed (rpm)	Rated motor efficiency (%)	Power factor	Rated current (A)	Rated torque (Nm)
0.55	80M	1LG0080-4AA..	1390	71.0	0.750	1.57	3.8
0.75	80M	1LG0083-4AA..	1380	73.0	0.760	2.05	5.2
1.1	90S	1LG0090-4AA..	1390	76.2	0.760	2.89	7.6
1.50	90L	1LG0096-4AA..	1390	78.5	0.790	3.67	10.3
2.20	100L	1LG0106-4AA..	1410	81.0	0.800	5.16	14.9
3.00	100L	1LG0107-4AA..	1410	82.8	0.810	6.80	20.3
4.00	112M	1LG0113-4AA..	1435	84.5	0.820	8.80	26.6
5.50	132S	1LG0130-4AA..	1440	86.0	0.820	11.80	36.5
7.50	132M	1LG0133-4AA..	1440	87.2	0.840	15.60	49.7
11.00	160M	1LG0163-4AA..	1460	89.0	0.830	22.60	72.0
15.00	160L	1LG0166-4AA..	1460	90.0	0.840	30.10	98.1
18.50	180M	1LG0183-4AA..	1470	90.6	0.860	36.10	120.2
22.00	180L	1LG0186-4AA..	1470	91.4	0.860	42.50	143.0

6.5 Inverter status display

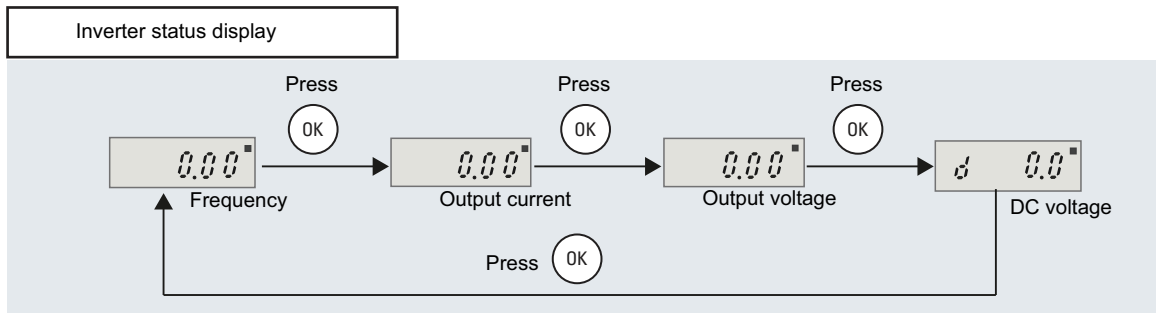

Figure 6-16 Inverter status display

Frequency setpoint and actual value changeover

Different from "Output current", "Output voltage" or "DC voltage" display, after switching to the "Frequency" status display, you can change between frequency setpoint and actual frequency displays.

When motor starts running, the frequency setpoint appears and inverter status indicator for "SETTING" is visible. You can change the setpoint by turning the OK button. When stop turning OK, the value shown is an actual value and the inverter status indicator for "SETTING" becomes invisible.

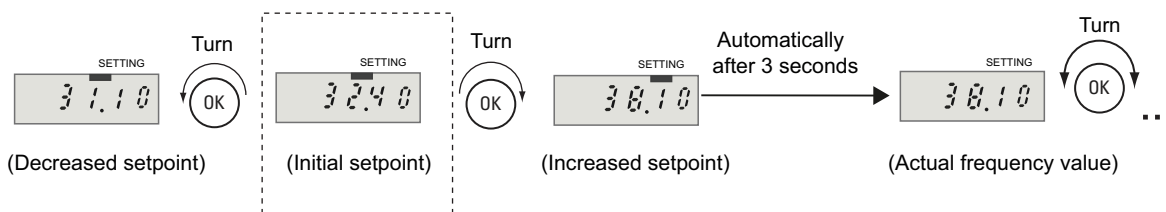

Figure 6-17 Frequency status changeover (example)

Note

The default display at first power-on is the frequency. To change the default display, go to P0005. If you don't turn OK for about 30 seconds, the display automatically switches back to the value set via P0005.

The frequency value may increase or decrease by 1 Hz or 0.1 Hz, depending on the speed at which you turn OK.

6.6 Overview of various operation modes

6.6.1 Operation mode ① - Quick motor data setting

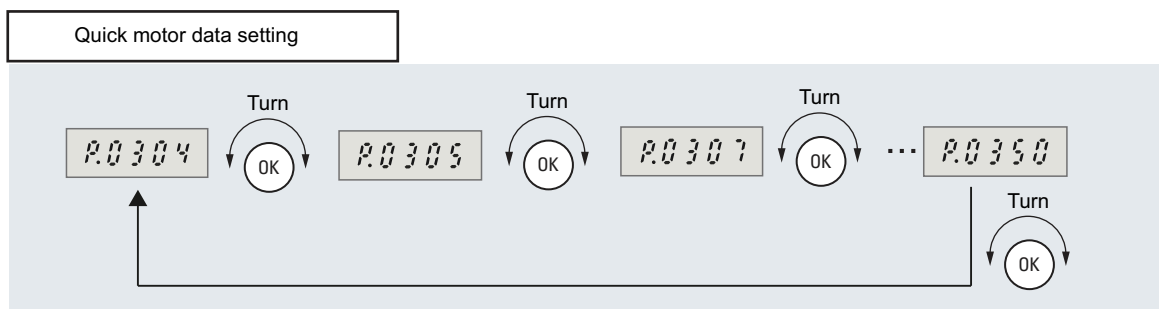

Figure 6-18 Quick motor data setting

Parameters available for setting in this mode

P0304, P0305, P0307 ... P0311, P0320, P0335 and P0350

NOTICE

P.0304 is always the default display in this mode.

Parameters available for setting in this mode can also be shown in the "Access all the parameters" mode. However, in the "Access all the parameters" mode, these parameters are read-only. To easily differentiate, the parameter number shown in the "Quick motor data setting" mode has a dot (.) after "P".

Parameter setting in "Quick motor data setting" mode

Example: P0304

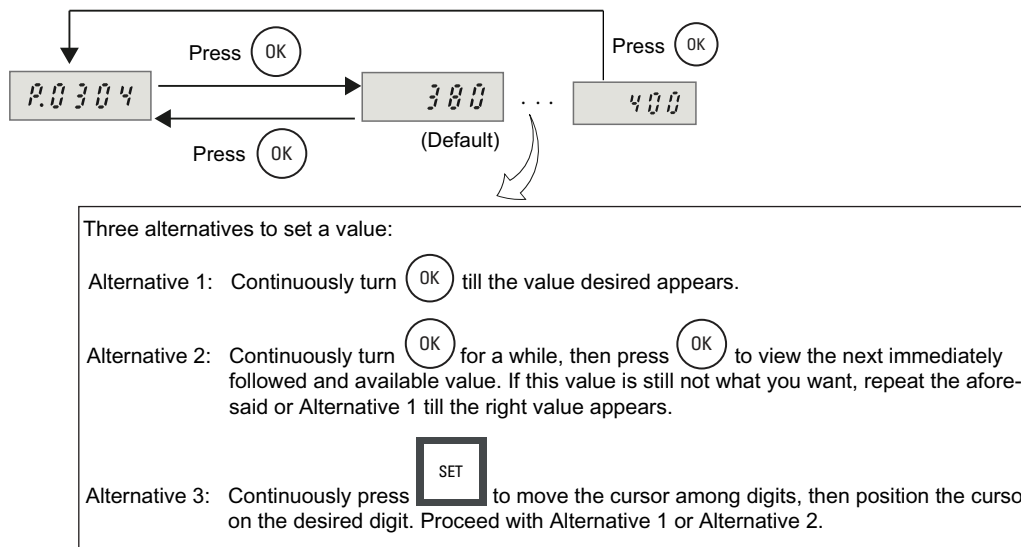

Figure 6-19 Parameter setting example (P0304)

Note

The value set by pressing OK will be displayed by default next time.

The digit bit can be dynamically changed according to the parameter value.

Button/keys inactive in this mode

The STOP, RUN and LOC/REM keys are inactive in this mode.

6.6.2 Operation mode ② - Connection macro selection

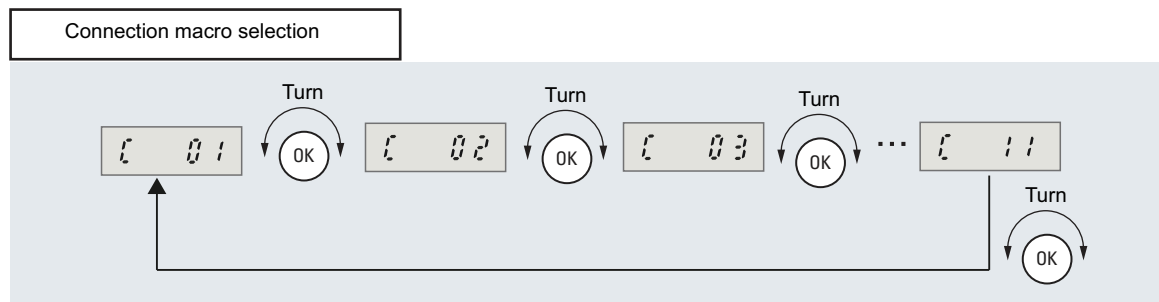

Figure 6-20 Connection macro selection

NOTICE

The connection macro to be displayed by default depends on the actual wiring. Make sure that your wiring corresponds with the connection macro selected. For details, please see Typical connection modes (Page 39)

Connection macros available for setting in this mode

C01 to C11

Connection macro setting in "Connection macro selection" mode

Example: C07

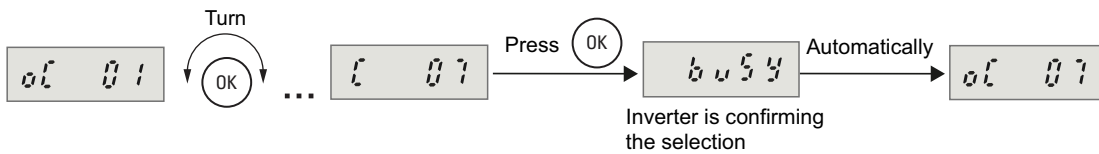

Figure 6-21 Connection macro setting example

NOTICE

If the inverter is confirming the selection of a connection macro, time consumption is about 50 seconds; if it is confirming the selection of an application macro, the time consumption is about 20 seconds.

Button/keys inactive in this mode

The STOP, RUN and LOC/REM keys are inactive in this mode.

6.6.3 Operation mode ③ - Application macro selection

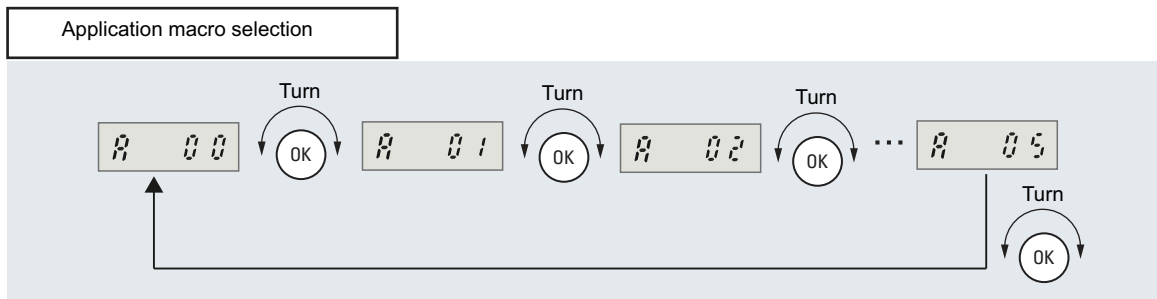

Figure 6-22 Application macro selection

Application macros available for setting in this mode

A00 to A05

Application macro setting in "Application macro selection" mode

Example: A05

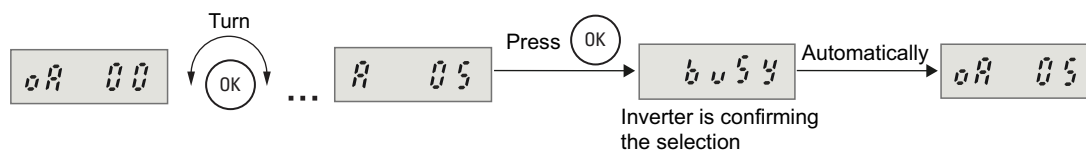

Figure 6-23 Application macro setting example

NOTICE

If the inverter is confirming the selection of a connection macro, time consumption is about 50 seconds; if it is confirming the selection of an application macro, the time consumption is about 20 seconds.

Button/keys inactive in this mode

The STOP, RUN and LOC/REM keys are inactive in this mode.

See also

Application macros (Page 56)

6.6.4 Operation mode ④ - Common application macro specific parameter setting

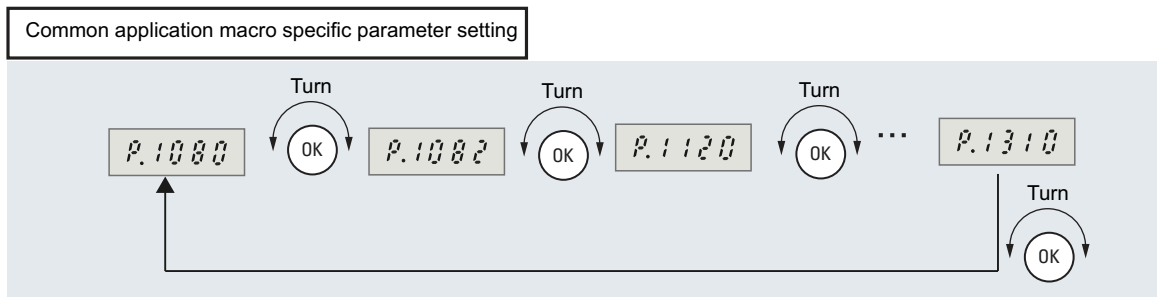

Figure 6-24 Common application macro specific parameter setting

Parameters available for setting in this mode

P1080, P1082, P1120, P1121, P1210 and P1310

NOTICE

Parameters available for setting in this mode can also be shown in the "Access all the parameters" mode. To easily differentiate, the parameter number shown in the "Common application macro specific parameter setting" mode has a dot (.) after "P".

You can set a parameter value either in this mode or in the "Access all parameters" mode. Once the value is set, it will be simultaneously updated in both modes.

Parameter setting in "Application macro specific parameter setting" mode

See the second figure in topic "Operation mode ① - Quick motor data setting (Page 66)" for parameterization method.

Button/keys inactive in this mode

The STOP, RUN and LOC/REM keys are inactive in this mode.

6.6.5 Operation mode ⑤ - Access all the parameters

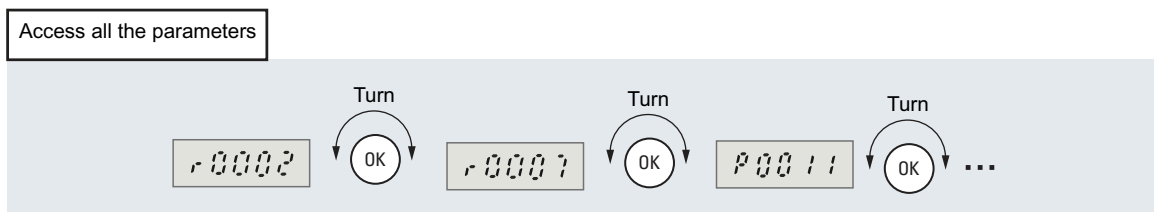

Figure 6-25 Access all the parameters (example)

Parameters available for setting and reading in this mode

All the read-only parameters (including quick motor data setting specific parameters) and settable parameters.

Parameter setting in "Access all the parameters" mode

- Setting a normal parameter

See the second figure in topic "Operation mode ① - Quick motor data setting (Page 66)" for parameterization method.

- Setting an indexed parameter

Example: r0207[2]

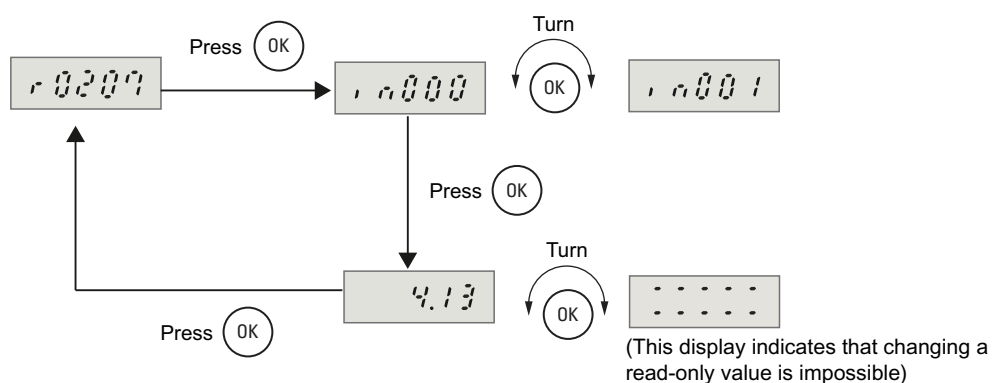

Figure 6-26 Setting an indexed parameter (example)

- Viewing a normal read-only parameter

Example: r0007

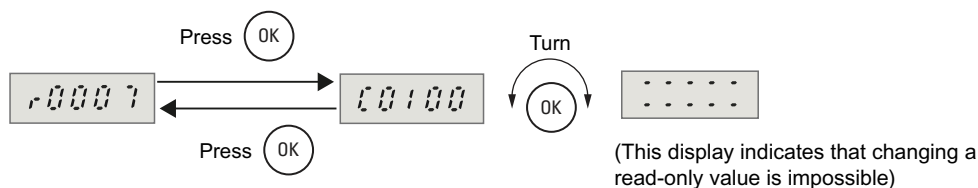

Figure 6-27 Viewing a normal read-only parameter (example)

Note

The procedure to set an indexed editable parameter (Pxxxx[x]) is the same as shown in this example.

The alternatives to change parameter values are the same as afore-described under Fig. 6-8, but one exception is: if the value range available for setting consists of discontinuous values (for example, for P0005), when you turn OK to appear a value that is not available for this parameter and then press OK, an error indication ("Err-") will appear indicating value setting is impossible. Then, the display will automatically jump to the next immediately followed and available-for-setting value.

Button/keys inactive in this mode

If the current connection macro selected is "C01xx" or "C05xx", the LOC/REM key is inactive in this mode.

The STOP and RUN keys are active when one of the preconfigured connection modes is selected and currently the command source is from the operator panel.

The OK button and the SET key are always active in this mode.

Long-pressed STOP key is always active.

6.7 Factory reset

Factory reset (P0970)

Proceed the following steps to perform a factory reset:

1. Stop the motor operation.
2. Go to the "Access all the parameters" mode, set P0970 to desired value (please refer to below table).

Possible settings of P0970	
0	Disabled
48	All parameters and connection macros reset
49	All parameters (except motor data P0304, P0305, P0307 ... P0311, P0320, P0335, P0350) and connection macro settings reset

6.8 Cloning parameters with the operator panel

A single parameter set can be uploaded into an inverter, and then downloaded into another inverter. To clone a parameter set from one inverter to another one, please follow below procedures:

1. Connect the operator panel to the inverter;
2. Ensure that it is safe to stop the inverter;
3. Stop the inverter;
4. Enter into "Operation mode ⑤ - Access all the parameters (Page 71)" mode, and set P0800 = 1 to start uploading parameters;
5. The operator panel displays "busy" during the parameter uploading;
6. During the parameter uploading, both the operator panel and the inverter will not give any response to any commands;
7. When the parameter uploading has been completed successfully, the operator panel display returns to its normal state while the inverter returns to a ready state;
8. If the parameter uploading has failed, F0055 will be displayed on the operator panel. In this case, please check the operator panel to clear this fault, and try uploading parameters again;
9. Remove the operator panel from the inverter;
10. Connect the operator panel to a new inverter;
11. Ensure that power has been applied to the inverter;
12. Enter into "Operation mode ⑤ - Access all the parameters (Page 71)" mode, and set P0801 = 1 to start downloading parameters;
13. The operator panel displays "busy" or "- -" during the parameter downloading;
14. During the parameter downloading, both the operator panel and the inverter will not give any response to any command;
15. When the parameter downloading has been completed successfully, the operator panel returns to its normal state while the inverter returns to a ready state;

6.8 Cloning parameters with the operator panel

16.If the parameter downloading has failed:

- If it is out of the failure to verify the downloading work, the operator panel will display F0057. In this case, please try downloading the parameters again;
- If the failure happens during the downloading work, the operator panel will reset the inverter to "Out of Box", and display F0056. After clearing this fault, please retry the downloading work;
- If this new inverter does not has the same frame size with the previous one, the operator panel will display F0058 when the downloading has finished successfully; you must configure the settings of necessary parameters again according to your own needs;

17.And now the operator panel can be removed from the inverter.

The following important restrictions must be considered when you are doing the parameter cloning:

- Only the current datasheet is uploaded to the operator panel.
- Once begun, the cloning procedure can not be interrupted.
- Parameters can be copied between inverters of different power ratings;, but motor specific parameters, P0611 and P0640 can not be copied.
- During the downloading work, if the data are not compatible with the inverter, the default values for the parameters will be written into the inverter.
- During the parameter uploading, all the data in the operator panel will be overwritten; when the downloading procedure has begun, all the data in the inverter will be overwritten.
- If the uploading work or the downloading work has failed, the inverter will not work normally.

NOTICE
After cloning parameters between two different control modes, you have to switch between LOC mode and REM mode according to actual application.

Parameter list

Parameter groups

Table 7-1 Inverter status specific parameters

Parameter No.	Name
r0002	Inverter state
r0007	Selected connection macro and application macro
r0018[2]	Inverter version display
r0024	Actual inverter output frequency
r0025	Actual output voltage
r0026	Actual DC-link voltage
r0027	Actual output current
r0037	Inverter temperature
r0052	Actual Status word 1
r0206	Rated inverter power
r0207[2]	Rated inverter current
r0208	Rated inverter voltage
r0209	Max. inverter current
r0752	Act. input of ADC [V]
r0947[8]	Last fault code
r1119	CO: Freq. setpoint before RFG
r2036	Ctr/Wrd1 from operator panel
r2110[4]	Warning number

Table 7-2 Motor data (for quick commissioning)

Parameter No.	Name
P0304	Rated motor voltage
P0305	Rated motor current
P0307	Rated motor power
P0308	Rated motor cosPhi
P0309	Rated motor efficiency
P0310	Rated motor frequency
P0311	Rated motor speed
P0320	Motor magnetizing current
P0335	Motor cooling
P0350	Stator resistance (line-to-line)

Table 7-3 Digital I/O specific parameters

Parameter No.	Name
P0701	Function of digital input 1
P0702	Function of digital input 2
P0703	Function of digital input 3
r0722	Binary input values
P0725	PNP/NPN digital inputs
P0731	Function of digital output 1
P0748	Invert digital outputs

Table 7-4 Analog I/O specific parameters

Parameter No.	Name
P0753	Smooth time ADC
P0757	Value x1 of ADC scaling
P0758	Value y1 of ADC scaling
P0759	Value x2 of ADC scaling
P0760	Value y2 of ADC scaling
P0761	Width of ADC deadband
P0771	DAC
P0773	Smooth time DAC
P0777	Value x1 of DAC scaling
P0778	Value y1 of DAC scaling
P0779	Value x2 of DAC scaling
P0780	Value y2 of DAC scaling
P0781	Width of DAC deadband

Table 7-5 Frequency reference specific parameters

Parameter No.	Name
P1040	Setpoint of the MOP
P1000	Selection of freq. setpoint
P1074	Disabling an additional setpoint
P1020	Fixed frequency selection 1
P1021	Fixed frequency selection 2
P1001	Fixed frequency 1
P1002	Fixed frequency 2
P1003	Fixed frequency 3
P1031	Setpoint memory of the MOP
P1058	JOG frequency right
P1059	JOG frequency left
P1080	Min. frequency
P1082	Max. frequency
P1110	Inhibit neg. freq. setpoint

Parameter No.	Name
P1135	OFF3 ramp-down time
P0840	Selection of the ON/OFF1 command source
P0844	Selection of the OFF2 command source
P1032	Inhibiting negative set points of MOP

Table 7-6 Control parameters

Parameter No.	Name
P1091	Skip frequency
P1101	Skp frequency bandwidth
P1120	Ramp-up time
P1121	Ramp-down time
P1130	Ramp-up initial rounding time
P1131	Ramp-up final rounding time
P1132	Ramp-down initial rounding time
P1133	Ramp-down final rounding time
P1215	Holding brake enable
P1216	Holding brake release delay
P1217	Holding time after ramp down
P1230	BI: Enable DC braking
P1232	DC braking current
P1233	Duration of DC braking
P1236	Compound braking current
P1310	Continuous boost
P1311	Acceleration boost
P1312	Starting boost
P1910	Select motor data identification
P2200	Enable PI controller
P2231	Setpoint memory of PI-MOP
P2240	Setpoint of PI
r2262	Filtered PI setpoint after RFG
r2272	PI scaled feedback
r2273	PI error
P2291	PI output upper limit
P2292	PI output lower limit
r2294	Actual PI output

Table 7-7 Protection specific parameters

Parameter No.	Name
P0011	Lock for user defined par.
P0012	Key for user defined par.
P0013	User defined parameter
P0210	Supply voltage

Parameter No.	Name
P0290	Inverter overload reaction
P0294	Inverter I ² T overload warning
P0610	Motor I ² T reaction
P0611	Motor I ² T time constant
P0640	Motor overload factor

Table 7-8 Other parameters

Parameter No.	Name
P0005	Display selection
P0970	Factory reset
P0971	Transfer data from RAM to EEPROM
P1080	Min. frequency
P1082	Max. frequency
P1120	Ramp-up time
P1121	Ramp-down time
P1200	Flying start
P1202	Motor-current: Flying start
P1203	Search rate: Flying start
P1210	Automatic restart
P1240	Configuration of Vdc controller
P1300	Control mode
P1800	Pulse frequency
P2000	Reference frequency
P2280	PI proportion gain
P2285	PI integral time
P2293	Ramp-up/-down time of PI limit

Notes on the OFF functions

OFF1 - This command (produced by cancelling the ON command) causes the inverter to come to a standstill at the selected ramp-down rate. (Active by pressing STOP for less than 2 seconds)

OFF2 - This command causes the motor to coast to a standstill. (Active by pressing STOP for more than 2 seconds) Both OFF2 and OFF3 are effective at low voltage, and OFF2 enjoys the highest priority.

OFF3 - This command causes the motor to decelerate rapidly.

Parameter list

Table 7-9 Parameter list

Par. No.	Name	Range	Default	Unit
r0002	Inverter state	--	--	--
	Displays actual inverter state.			
	0	Commissioning mode		
	1	Inverter ready		
	2	Inverter fault active		
	3	Inverter starting (DC-link precharging)		
	4	Inverter running		
P0005	Display selection	21 - 27	21	--
	Selects display of the user-selected output			
	21	Actual frequency		
	25	Output voltage		
	26	DC link voltage		
r0007	Selected connection macro and application macro	C0100 - C1005	C0100	--
	Displays selected connection macro and application macro			
	C0100	Connection macro C01 and application macro A00 are selected		
	C0101	Connection macro C01 and application macro A01 are selected		
	...			
	C1005	Connection macro C10 and application macro A05 are selected		
	Note:			
	Default value depends on selected connection macro and application macro.			
P0011	Lock for user-defined parameter	0 - 65535	0	--
	Password to lock user-defined parameter.			
P0012	Key for user-defined parameter	0 - 65535	0	--
	Password to unlock user-defined parameter.			

Parameter list

Par. No.	Name	Range	Default	Unit
P0013[16]	User defined parameter	0 - 65535	0	--
	Defines a limited set of parameters to which the end user will have access right.			
	Index:			
	P0013[0]	1st user parameter		
	P0013[1]	2nd user parameter		
	...			
	P0013[15]	16th user parameter		
	Dependency:			
	To prevent changes to user-defined parameter, set P0011 ("lock") to a different value than P0012 ("key").			
	When locked and the user-defined parameter is activated, the only way to exit the user-defined parameter (and view other parameters) is to set P0012 ("key") to the value in P0011 ("lock")			
	Note:			
	<ul style="list-style-type: none"> Alternatively, set P0970 = 48 (factory reset) to perform a factory reset of all parameters and selected connection macro or set P0970 = 49 (factory reset) to perform a factory reset of all parameters (except parameters for quick motor data settings) and selected connection macro. The default values of P0011 ("lock") and P0012 ("key") are the same 			
r0018[2]	Inverter version display	--	--	--
	Displays firmware version number of the inverter or the operator panel			
	r0018[0]:	Inverter firmware version		
	r0018[1]:	Firmware version of the operator panel		
r0024	Actual inverter output frequency	--	--	Hz
	Displays actual output frequency. Slip compensation, resonance damping and frequency limitation are included.			
r0025	Actual output voltage	--	--	V
	Displays [rms] voltage applied to motor.			
r0026	Actual DC-link voltage	--	--	V
	Displays DC-link voltage.			
r0027	Actual output current	--	--	A
	Displays [rms] value of motor current [A].			
r0037	Inverter temperature [°C]	--	--	°C
	Displays internal inverter heatsink temperature.			

Par. No.	Name	Range	Default	Unit
r0052	Actual status word 1	--	--	--
	Displays first active status word of inverter (bit format) and can be used to diagnose inverter status.			
	Bit fields:			
	Bit00	Inverter ready	0 NO	1 YES
	Bit01	Inverter ready to run	0 NO	1 YES
	Bit02	Inverter running	0 NO	1 YES
	Bit03	Inverter fault active	0 NO	1 YES
	Bit04	OFF2 active	0 YES	1 NO
	Bit05	OFF3 active	0 YES	1 NO
	Bit06	ON inhibit active	0 NO	1 YES
	Bit07	Inverter warning active	0 NO	1 YES
	Bit08	Deviation setpoint / actual value	0 YES	1 NO
	Bit09	PZD control	0 NO	1 YES
	Bit10	Maximum frequency reached	0 NO	1 YES
	Bit11	Warning: Motor current limit	0 YES	1 NO
	Bit12	Motor holding brake active	0 NO	1 YES
	Bit13	Motor overload	0 YES	1 NO
	Bit14	Motor runs right	0 NO	1 YES
	Bit15	Inverter overload	0 YES	1 NO
	Note:			
	For the explanation of the 7-segment display of the bit-parameters (binary parameters), see topic "Operator panel overview (Page 58)"			
r0206	Rated inverter power	--	--	kW
	Displays nominal rated motor power from inverter.			
r0207[2]	Rated inverter current	--	--	A
	Displays maximum continuous output current of inverter.			
	r0207[0] :	Rated inverter current		
	r0207[1] :	Rated motor current of a 4-pole 1LA7 AC motor.		
	Note:			
	Under this index 1, you can only view the rated motor current of a 4-pole 1LA7 AC motor. To view the actual motor current, go to P0305.			
r0208	Rated inverter voltage	--	--	V
	Displays nominal AC supply voltage of inverter.			
	Value:			
	r0208 = 400 (400 V, tolerance: -15% - +15%)			
r0209	Maximum inverter current	--	--	A
	Displays maximum output current of inverter.			
	Dependency:			
	Parameter r0209 depends on the derating which is affected by pulse frequency P1800, ambient temperature and altitude. The data of derating is given in the Operating Instructions.			

Parameter list

Par. No.	Name	Range	Default	Unit
P0210	Supply voltage	0 - 1000	400	V
	Parameter P0210 defines the supply voltage. Its default value depends upon the type of inverter. If P0210 does not correspond to the supply voltage, then it must be modified.			
	Note: If mains voltage is higher than value entered, automatic deactivation of the Vdc controller may occur to avoid acceleration of the motor. An alarm will be issued in this case (A0910).			
P0290	Inverter overload reaction	0 - 3	2	--
	Selects reaction of inverter to an internal over-temperature.			
	Possible settings:			
	0	Reduce output frequency		
		Note: Effective only if the load is also reduced. This is for example valid for variable torque applications with a quadratic torque characteristic as pumps or fans.		
	1	Trip (F0004)		
		Note: A trip will always result, if the action taken does not sufficiently reduce internal temperature.		
	2	Reduce pulse frequency and output frequency		
	3	Keep output frequency and reduce pulse frequency, then trip (F0004)		
P0294	Inverter I²t overload warning	10.0 - 100.0	95.0	%
	Defines the [%] value at which alarm A0505 (inverter I ² t) is generated.			
	Inverter I ² t calculation is used to determine a maximum tolerable period for inverter overload. The I ² t calculation value is deemed = 100% when this maximum tolerable period is reached.			
	Note: P0294 = 100% corresponds to stationary nominal load.			
P0304	Rated motor voltage	10 - 2000	400	V
	Nominal motor voltage [V] from rating plate.			
P0305	Rated motor current	0.01 - 10000.00	See table in Chap. 6.4	A
	Nominal motor current [A] from rating plate.			
	Note: The maximum value of P0305 depends on the maximum inverter current r0209. It is recommended that the ratio of P0305 (rated motor current) and r0207 (rated inverter current) should not be lower than: V/f: $1/8 \leq P0305/r0207 \leq r0209/1.1$ The absolute minimum value of P0305 is defined as 1/32 times inverter rated current (r0207).			
P0307	Rated motor power	0.01 - 2000.00	See table in Chap. 6.4	kW
	Nominal motor power from rating plate.			
P0308	Rated motor cosPhi	0.000 - 1.000	See table in Chap. 6.4	--
	Nominal motor power factor (cosPhi) from rating plate.			
	Dependency: Setting 0 causes internal calculation of value.			

Par. No.	Name	Range	Default	Unit
P0309	Rated motor efficiency	0.0 - 99.9	See table in Chap. 6.4	%
	Nominal motor efficiency in [%] from rating plate.			
	Dependency:			
	Setting 0 causes internal calculation of value.			
P0310	Rated motor frequency	12.00 - 300.00	50.00	Hz
	Nominal motor frequency [Hz] from rating plate.			
	Dependency:			
	Pole pair number recalculated automatically if parameter is changed.			
P0311	Rated motor speed	0 - 40000	See table in Chap. 6.4	1/min
	Nominal motor speed [rpm] from rating plate.			
	Dependency:			
	<ul style="list-style-type: none"> • Setting 0 causes internal calculation of value. • Slip compensation in V/f control requires rated motor speed for correct operation. • Pole pair number recalculated automatically if parameter is changed. • Required for vector control and V/f control with speed controller. 			
P0320	Motor magnetizing current	0.0 - 99.0	0.0	%
	Defines motor magnetization current in [%] relative to P0305 (rated motor current).			
P0335	Motor cooling	0 - 1	0	--
	Selects motor cooling system used.			
	Possible settings:			
	0	Self-cooled: Using shaft mounted fan attached to motor		
	1	Forced-cooled: Using separately powered cooling fan		
P0350	Stator resistance (line-to-line)	0.0001 - 2000.0	Depends on inverter type	Ohm
	Stator resistance value in [Ohms] for connected motor (from line-to-line). The parameter value includes the cable resistance.			
	$P0350 = 2 \times (R_{\text{cable}} + R_s)$			
	There are two ways to determine the value for this parameter:			
	1. Measure using P1910 = 1 (motor data identification - value for stator resistance is overwritten).			
	2. Measure manually using an Ohmmeter.			
	Note:			
	Default value depends on inverter type.			

Parameter list

Par. No.	Name	Range	Default	Unit
P0610	Motor I²t reaction	0 - 2	1	--
	Defines reaction when motor I ² t reaches warning threshold.			
	Possible settings:			
	0	Warning, no reaction, no trip		
	1	Warning, I _{max} reduction, trip F0011		
	2	Warning, no reaction, trip F0011		
	Dependency:			
	See parameter P0611.			
	Note:			
	Default value depends on connection macro selected. See Table 7-11 for details			
P0611	Motor I²t time constant	0 - 16000	Depends on inverter type	s
	Thermal time constant for the motor.			
	Dependency:			
	P0611 < 99 s: I ² T-calculation inactive			
	To activate I ² T calculation, set P0611 to a value > 99 s.			
	Note:			
	The value of P0611 is estimated according to the motor data during quick commissioning. When the calculation of motor parameters during quick commissioning is complete, the stored value can be replaced by the value given by the motor manufacturer.			
P0640	Motor overload factor [%]	10.0 - 400.0	110.0	%
	Defines motor overload current limit in [%] relative to P0305 (rated motor current).			
P0701	Function of digital input 1	0 - 99	0	--
	Selects function of digital input 1.			
	Possible settings:			
	0	Digital input disabled		
	1	ON/OFF 1		
	2	ON reverse/OFF1		
	3	OFF2 - coast to standstill		
	4	OFF3 - quick ramp down		
	9	Fault acknowledge		
	10	JOG right		
	11	JOG left		
	12	Reverse		
	13	MOP up (increase frequency)		
	14	MOP down (decrease frequency)		
	15	Fixed setpoint (direct selection)		
	16	Fixed setpoint (direct selection + ON)		
	99	Enable value 722.0 set in other parameters.		
	Note:			
	Default value depends on connection macro selected. See Table 7-11 for details			

Par. No.	Name	Range	Default	Unit
P0702	Function of digital input 2	0 - 99	0	--
	Selects function of digital inputs 2.			
	Possible settings:			
	Same as the settings of P0701 except value 99.			
	P0702 = 99 : Enable value 722.1 set in other parameters.			
	Note:			
	Default value depends on connection macro selected. See Table 7-11 for details			
P0703	Function of digital input 3	0 - 99	0	--
	Select function of digital input 3.			
	Possible settings:			
	Same as the settings of P0701 except value 99.			
	P0703 = 99 : Enable value 722.2 set in other parameters..			
	Note:			
	Default value depends on connection macro selected. See Table 7-11 for details			
r0722	Binary input values	--	--	--
	Displays status of digital inputs.			
	Bitfields:			
	Bit00	Digital input 1	0 OFF	1 ON
	Bit01	Digital input 2	0 OFF	1 ON
	Bit02	Digital input 3	0 OFF	1 ON
	Note:			
	<ul style="list-style-type: none"> • Segment is lit when signal is active • The 7-segment display of the bit-parameters (binary parameters) is explained in Fig. 6-12 of Section 6.3.2. 			
P0725	PNP/NPN digital inputs	0 - 1	1	--
	Switches between active high (PNP) and active low (NPN). This is valid inputs for all digital inputs simultaneously.			
	The following is valid by using the internal supply:			
	Possible settings:			
	0	NPN ⇒ low active		
	1	PNP ⇒ high active		
	Value:			
	NPN: terminals 7/8/9 can be connected via terminal 6 (0V)			
	PNP: terminals 7/8/9 can be connected via terminal 5 (24V)			

Parameter list

Par. No.	Name	Range	Default	Unit
P0731	Function of digital output 1	0.0 - 2036.F	52.2	--
	Defines source of digital output 1.			
	Possible settings:			
	0	Open		
	1	Closed		
	52.0	See parameter r0052 for the meaning of individual value settings.		
	...	Note:		
	52.F	The meaning of 52.0 corresponds to the description of Bit00, The meaning of 52.1 corresponds to the description of Bit01, the rest on the analogy of it.		
	722.0 ...	See parameter r0722 for the meaning of individual value settings.		
	722.2	Note:		
		The meaning of 722.0 corresponds to the description of Bit00, The meaning of 722.1 corresponds to the description of Bit01, the rest on the analogy of it.		
	2036.0 .	See parameter r0236 for the meaning of individual value settings.		
	..	Note:		
	2036.F	The meaning of 2036.0 corresponds to the description of Bit00, The meaning of 2036.1 corresponds to the description of Bit01, the rest on the analogy of it.		
P0748	Invert digital outputs	0 - 1	0	--
	Defines high and low states of relay for a given function.			
	Bitfields:			
	Bit00	Invert digital output 1	0	NO
			1	YES
	Note:			
	The 7-segment display of the bit-parameters (binary parameters) is explained in Fig. 6-2 of Chapter 6.			
r0752	Act. input of ADC [V]	--	--	--
	Displays smoothed analog input value in volts before the characteristic block.			
P0753	Smooth time ADC	0 - 10,000	300	ms
	Defines filter time (PT1 filter) in [ms] for analog input.			
	Note:			
	Increasing this time (smooth) reduces jitter but slows down responses to the analog input.			
	P0753 = 0: No filtering			

Par. No.	Name	Range	Default	Unit
P0757	Value x1 of ADC scaling [V]	0.00 - 10.00	0.00	V

Parameters P0757 - P0760 configure the input scaling as shown in the diagram:

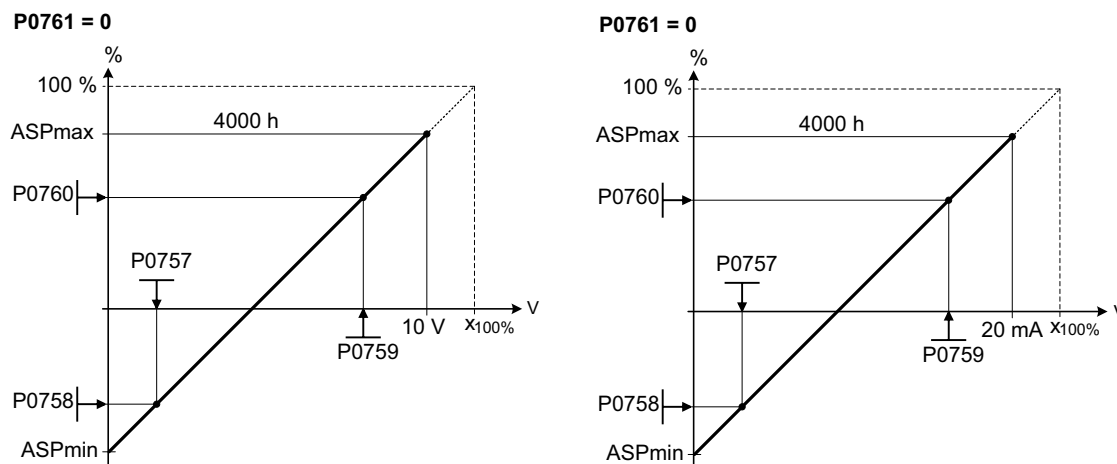

Where:

- Analog setpoints represent a [%] of the nominalized frequency in P2000.
- Analog setpoints may be larger than 100 %.
- ASPmax represents highest analog setpoint (this may be at 10 V / 20 mA).
- ASPmin represents lowest analog setpoint (this may be at 0 V / 0 mA).
- Default values provide a scaling of 0 V / 0 mA = 0%, and 10 V / 20 mA = 100%.

Note:

- The value x2 of ADC scaling P0759 must be greater than the value x1 of ADC scaling P0757.
- If P2200 = 1, P0757 to P0760 can only be set for PI feedback scaling.

P0758	Value y1 of ADC scaling	-99999 - 99999	0.00	%
-------	--------------------------------	----------------	------	---

Sets value of Y1 in [%] as described in P0757 (ADC scaling).

P0759	Value x2 of ADC scaling [V]	0.00 - 10.00	10.00	V
-------	------------------------------------	--------------	-------	---

Sets value of x2 as described in P0757 (ADC scaling).

Note:

The value x2 of ADC scaling P0759 must be greater than the value x1 of ADC scaling P0757.

P0760	Value y2 of ADC scaling	-99999 - 99999	100.00	%
-------	--------------------------------	----------------	--------	---

Sets value of Y2 in [%] as described in P0757 (ADC scaling).

P0761	Width of ADC deadband [V]	0.00 - 10.00	0.00	V
-------	----------------------------------	--------------	------	---

Defines width of deadband on analog input.

Parameter list

Par. No.	Name	Range	Default	Unit
P0771	DAC	0.0 - 2036.0	24.0	--
Defines function of the 0 - 20 mA analog output.				
Possible settings:				
0	Analog output current: 0 mA			
1	Analog output current: 20 mA			
24	Actual output frequency			
25	Actual output voltage			
26	Actual DC-link voltage			
27	Actual output current			
37	Actual inverter temperature			
P0773	Smooth time DAC	0 - 1,000	2	ms
Defines smoothing time [ms] for analog output signal. This parameter enables smoothing for DAC using a PT1 filter.				
Dependency:				
P0773 = 0: Deactivates filter				
P0777	Value x1 of DAC scaling	-99999 - 99999	0.00	%
Defines x1 output characteristic in [%]. Scaling block is responsible for adjustment of output value defined in P0771 (DAC connector input).				
Parameters of DAC scaling block (P0777 ... P0781) work as follows:				
<p>Output signal (mA)</p>				
Where:				
Points P1 (x1, y1) and P2 (x2, y2) can be chosen freely.				
P0778	Value y1 of DAC scaling	0.00 - 20.00	0.00	--
Defines y1 of output characteristic.				
P0779	Value x2 of DAC scaling	-99999 - 99999	100.00	%
Defines x2 of output characteristic in [%].				
P0780	Value y2 of DAC scaling	0.00 - 20.00	20.00	--
Defines y2 of output characteristic.				
P0781	Width of DAC deadband	0.00 - 20.00	0.00	--
Sets width of deadband in [mA] for analog output.				

Par. No.	Name	Range	Default	Unit
P0800	Parameter upload from inverter to operator panel	0 - 1	0	--
	With this parameter, you can upload parameters from an inverter to the operator panel.			
	Possible settings:			
	0	Disabled		
	1	Upload		
P0801	Parameter download from operator panel to inverter	0 - 1	0	--
	With this parameter, you can download parameters from the operator panel to an inverter.			
	Possible settings:			
	0	Disabled		
	1	Download		

Par. No.	Name	Range	Default	Unit
r0947[8]	Last fault code	--	--	--

Displays fault history according to the diagram below:

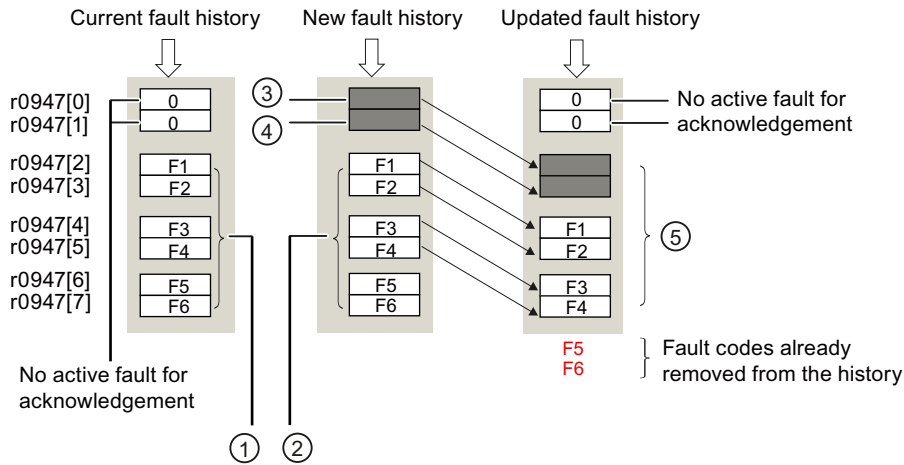

- ① Most recent and already acknowledged faults in "Current fault history"
- ② Most recent and already acknowledged faults in "New fault history"
- ③ 1st active fault (not yet acknowledged)
- ④ 2nd active fault (not yet acknowledged)
- ⑤ Most recent and already acknowledged faults in "Updated fault history"

Where:

Acknowledging the active faults will move the value in the 2 indicates down to the next pair of indicates, where they are stored. Indicates 0 & 1 contain the active faults. When faults are acknowledged, indicates 0 & 1 are reset to 0.

Index:

r0947[0]:	Recent fault trip - -, fault 1
r0947[1]:	Recent fault trip - -, fault 2
r0947[2]:	Recent fault trip - 1, fault 3
r0947[3]:	Recent fault trip - 1, fault 4
r0947[4]:	Recent fault trip - 2, fault 5
r0947[5]:	Recent fault trip - 2, fault 6
r0947[6]:	Recent fault trip - 3, fault 7
r0947[7]:	Recent fault trip - 3, fault 8

Dependency:

Index 1 used only if second fault occurs before first fault is acknowledged.

Par. No.	Name	Range	Default	Unit
P0970	Factory reset	0 - 99	0	--
	Resets parameters and/or connection modes to their default values			
	Possible settings:			
	0	Disabled		
	48	All parameters and connection macros reset		
	49	All parameters (except motor data P0304, P0305, P0307 ... P0311, P0320, P0335, P0350) and connection macro settings reset		
P0971	Transfer data from RAM to EEPROM	0 - 1	0	--
	Transfers values from RAM to EEPROM.			
	After parameterization by the user, he can			
	Possible settings:			
	0	Disabled		
	1	Start transfer		
	Note:			
	All values in RAM are transferred to EEPROM.			
	Parameter is automatically reset to 0 (default) after successful transfer			

Parameter list

Par. No.	Name	Range	Default	Unit
P1000	Selection of frequency setpoint	0 - 53	5	--
	Selects frequency setpoint source.			
	Possible settings:			
0	No main setpoint	-		
1	MOP setpoint		default value for the remote mode of C02 and C10	
2	Analog setpoint		default value for the remote mode of C03~C05 and C07~C09	
3	Fixed frequency		default value for the remote mode of C06	
5	Operator panel		default value for C01 and C11 and for the local mode of C02~C10	
12	Analog setpoint + MOP setpoint		can be used for the remote mode of C02~C10 and C11 if the function of DI reconfigured	
13	Fixed frequency + MOP setpoint		can be used for the remote mode of C02~C10 and C11 if the function of DI reconfigured	
21	MOP setpoint + Analog setpoint		can be used for the remote mode of C02~C10 and C11 if the function of DI reconfigured	
23	Fixed frequency + Analog setpoint		can be used for the remote mode of C02~C10 and C11 if the function of DI reconfigured	
25	operation panel + Analog setpoint		can be used for C11 if the function of DI reconfigured	
31	MOP setpoint + Fixed frequency		can be used for the remote mode of C02~C10 and C11 if the function of DI reconfigured	
32	Analog setpoint + Fixed frequency		can be used for the remote mode of C02~C10 and C11 if the function of DI reconfigured	
35	operation panel + Fixed frequency		can be used for C11 if the function of DI reconfigured	
52	Analog setpoint + operation panel		can be used for C11 if the function of DI reconfigured	
53	Fixed frequency + operation panel		can be used for C11 if the function of DI reconfigured	
	Note:			
	Default value depends on connection macro selected. See Table 7-11 for details.			
	For users who are familiar with MM4 serial converters, the value from the operation panel (P1000 = 5) equals to the USS on COM link of MM serial converters.			
P1074	Disabling an additional setpoint	0.0 - 2036.F	0.0	-
	Common settings:			
	P1074 = 722.2 => Digital input 3			
	Dependency:			
	Accessible only if P0701 - P0703 = 99 (enabling the use of 722.0 - 722.2)			

Par. No.	Name	Range	Default	Unit
P1020	Fixed frequency selection 1	0.0 - 2036.F	0.0	-
	Common settings:			
	P1020 = 722.0 => Digital input 1			
	Dependency:			
	Accessible only if P0701 - P0703 = 99 (enabling the use of 722.0 - 722.2)			
	See the table in P1001 (fixed frequency 1) for the description of how to use fixed frequencies.			
	If both 1020 and 1021 are selected, the fixed setpoint is the sum of P1001 and 1002.			
P1021	Fixed frequency selection 2	0.0 - 2036.F	0.0	-
	Common settings:			
	P1021 = 722.1 ==> Digital input 2			
	Dependency:			
	Accessible only if P0701 - P0703 = 99 (enabling the use of 722.0 - 722.2)			
	See the table in P1002 (fixed frequency 2) for the description of how to use fixed frequencies			
	If both 1020 and 1021 are selected, the fixed setpoint is the sum of P1001 and 1002.			
Note: For users who are familiar with MM4 serial converters, parameters P1020 and P1021 have the same function with MM4 converters if P1016 and P1017 are set to 1.				
P1001	Fixed frequency 1	-300.00 - 300.00	0.00	Hz
	Defines fixed frequency setpoint 1.			
	There are three options available for the selection of fixed frequencies:			
	1. Direct selection (P0701 ... P0703 = 15)			
	In this mode of operation, 1 digital input selects 1 fixed frequency.			
	If several inputs are active at the same time, the selected frequencies are summed up.			
	2. Direct selection + ON command (P0701 ... P0703 = 16)			
	The fixed frequency selection integrates fixed frequencies with an ON command.			
	In this mode of operation, 1 digital input selects 1 fixed frequency.			
	If several inputs are active at the same time, the selected frequencies are summed up.			
	3. Direct selection multifunction (P0701 ... P0703 = 99; P1020 = 722.0 ... 2 and P1021 = 722.0 ... 2)			
	In this mode of operation, 1 digital input selects 1 fixed frequency.			
	If several inputs are active at the same time, the selected frequencies are summed up.			
	This mode is an alternative of option 1, except P0701 ... P0703 = 99, the used digital input can also act as other functions.			
P1002	Fixed frequency 2	-300.00 - 300.00	5.00	Hz
	Defines fixed frequency setpoint 2.			
	For Details, see parameter P1001 (fixed frequency 1).			
P1003	Fixed frequency 3	-300.00 - 300.00	10.00	Hz
	Defines fixed frequency setpoint 3			
	For Details, see parameter P1001(fixed frequency 1)			

Parameter list

Par. No.	Name	Range	Default	Unit
P1031	Setpoint memory of the MOP	0 - 1	0	--
	Saves last motor potentiometer setpoint (MOP) that was active before OFF command or power down.			
	Possible settings:			
	0	MOP setpoint will not be stored.		
	1	MOP setpoint will be stored (P1040 is updated).		
	Note:			
	1. On next ON command, motor potentiometer setpoint will be the saved value in parameter P1040 (setpoint of the MOP)			
	2. This parameter also decides whether the operator panel store current setpoint			
P1040	Setpoint of the MOP	-300.00 - 300.00	5.00	Hz
	Determines setpoint for motor potentiometer control (P1000 = 1)			
	Note:			
	1. If P1110 = 0, the setpoint of the MOP will be decreased to a negative value.			
	2. Default frequency setpoint of the operator panel depends on this parameter			
P1058	JOG frequency right	0.00 - 300.00	5.00	Hz
	Jogging increases the motor frequency by small amounts. The JOG buttons uses a non-latching switch on one of the digital inputs to control the motor frequency.			
	While JOG right is selected, this parameter determines the frequency at which the inverter will run.			
P1059	JOG frequency left	0.00 - 300.00	5.00	Hz
	While JOG left is selected, this parameter determines the frequency at which the inverter will run.			
P1080	Min. frequency	0.00 - 300.00	0.00	Hz
	Set minimum motor frequency [Hz] at which motor will run irrespective of frequency setpoint.			
P1082	Max. frequency	0.00 - 300.00	50.00	Hz
	Sets maximum motor frequency [Hz] at which motor will run irrespective of the frequency setpoint. The value set here is valid for both clockwise and anticlockwise rotation.			
	Furthermore, the monitoring function [f_act] >= P1082 is affected by this parameter.			
	Note:			
	Make sure that P1082 / P2000 < 2			

Par. No.	Name	Range	Default	Unit
P1091	Skip frequency	0.00 - 300.00	0.00	Hz
	Defines skip frequency which avoids effects of mechanical resonance and suppresses frequencies within +/- P1101 (skip frequency bandwidth).			
	<p>Note:</p> <ul style="list-style-type: none"> Stationary operation is not possible within the suppressed frequency range; the range is merely passed through (on the ramp). For example, if P1091 = 10 Hz and P1101 = 2Hz, it is not possible to operate continuously between 10 Hz +/- 2 Hz (i.e., between 8 and 12 Hz) 			
P1101	Skip frequency bandwidth	0.00 - 10.00	2.00	Hz
	Delivers frequency bandwidth to be applied to skip frequency.			
P1110	Inhibit negative frequency setpoint	0.0 - 2036.F	1.0	--
	This parameter suppresses negative setpoints. Therefore, modification of the motor direction is inhibited to the setpoint channel.			
	Possible settings:			
0	Disabled			
1	Enabled			
52.0	See parameter r0052 for the meaning of individual value settings.			
...	Note:			
52.F	The meaning of 52.0 corresponds to the description of Bit00, The meaning of 52.1 corresponds to the description of Bit01, the rest on the analogy of it.			
722.0	See parameter r0722 for the meaning of individual value settings.			
...	Note:			
722.2	The meaning of 722.0 corresponds to the description of Bit00, The meaning of 722.1 corresponds to the description of Bit01, the rest on the analogy of it.			
2036.0	See parameter r0236 for the meaning of individual value settings.			
...	Note:			
2036.F	The meaning of 2036.0 corresponds to the description of Bit00, The meaning of 2036.1 corresponds to the description of Bit01, the rest on the analogy of it.			
	<p>Note:</p> <ul style="list-style-type: none"> if a min. frequency (P1080) and a negative setpoint are given, the motor is accelerated by a positive value in relationship to the min. frequency. This function does not disable the "reverse command functions" (e.g. Reverse, ON left); rather, a reverse command causes motor to run in the positive direction only, as described above. Default value depends on connection macro selected. See Table 7-11 for details. 			
P0840	Selection of the ON/OFF1 command source	0.0 - 2036.F	722.0	-

Parameter list

Par. No.	Name	Range	Default	Unit				
P0844	Selection of the OFF2 command source	0.0 - 2036.F	1.0	-				
<p>Note: If P0840 and P0844 are wired together by the same input (i.e. P701 = 99; P0840 = 722.0; P0844 = 722.0), then the input will act as the ON/OFF2 function. OFF2 has a priority to OFF1.</p>								
P1032	Inhibiting negative set points of MOP	0 - 1	1	-				
<p>Possible settings:</p> <table border="1"> <tr> <td>0</td> <td>Negative MOP set point allowed</td> </tr> <tr> <td>1</td> <td>Negative MOP set point inhibited</td> </tr> </table>					0	Negative MOP set point allowed	1	Negative MOP set point inhibited
0	Negative MOP set point allowed							
1	Negative MOP set point inhibited							
<p>Note: The reversing functions are not affected by the settings of P1032, which only restrict an MOP setpoint. Please use P1110 to fully prevent any change of direction in a setpoint channel. Setting P1110 to 1 will set P1032 to 1 automatically. Setting P1032 to 1 will reset the saved negative MOP value (if P1040 < 0.0) to 0.0 automatically.</p>								
r1119	CO: Frequency setpoint before RFG	--	--	Hz				
<p>Displays output frequency after modification by other functions, e.g.:</p> <ul style="list-style-type: none"> • P1110 BI: Inhibit neg. frequency setpoint. • P1091 skip frequencies. • P1082 Min frequency. • P1082 Max. frequency. • Limitations • Etc. 								
P1120	Ramp-up time	0.00 - 300.00	30.00	s				
<p>Time taken for motor to accelerate from standstill up to maximum motor frequency (P1082) when no rounding is used.</p>								
<p>Note :</p> <ul style="list-style-type: none"> • Setting the ramp-up time too short can cause the inverter to trip (overcurrent). • If an example frequency setpoint with set ramp rates is used (e.g. from a PLC), the best way to achieve optimum inverter performance is to set ramp times in P1120 and P1121 slightly shorter than those of the PLC. 								
P1121	Ramp-down time	0.00 - 300.00	30.00	s				
<p>Time taken for motor to decelerate from maximum motor frequency (P1082) down to standstill when no rounding is used.</p>								
P1130	Ramp-up initial rounding time	0.00 - 40.00	0.00	s				

Defines initial rounding time in seconds as shown on the diagram below.

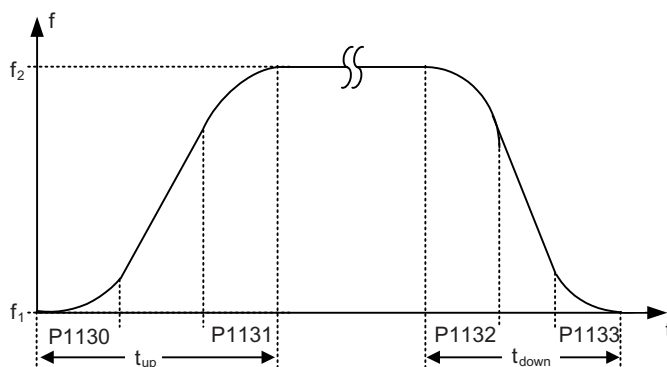

Par. No.	Name	Range	Default	Unit
P1131	Ramp-up final rounding time	0.00 - 40.00	0.00	s
	Defines rounding time at end of ramp-up as shown in P1130.			
P1132	Ramp-down initial rounding time	0.00 - 40.00	0.00	s
	Defines rounding time at start of ramp-down as shown in P1130.			
P1133	Ramp-down final rounding time	0.00 - 40.00	0.00	s
	Defines rounding time at end of ramp-down as shown in P1130.			
P1135	OFF3 ramp-down time	0.00 - 300.00	5.00	s
	Defines ramp-down time from maximum frequency to standstill for OFF3 command.			
P1200	Flying start	0 - 6	0	--
	Starts inverter onto a spinning motor by rapidly changing the output frequency of the inverter until the actual motor speed has been found. Then, the motor turns up to setpoint using the normal ramp time.			
	Possible settings:			
	0	Flying start disabled		
	1	Flying start is always active, start in direction of setpoint		
	2	Flying start is active if power on, fault, OFF2, start in direction of setpoint		
	3	Flying start is active if fault, OFF2, start in direction of setpoint		
	4	Flying start is active, only in direction of setpoint		
	5	Flying start if power on, fault, OFF2, only in direction of setpoint		
	6	Flying start if active if fault, OFF2, only in direction of setpoint		
P1202	Motor-current: Flying start	10 - 200	100	%
	Defines search current used for flying start. Value is in [%] based on rated motor current (P0305).			
P1203	Search rate: Flying start	10 - 200	100	%
	Sets factor by which the output frequency changes during flying start to synchronize with turning motor.			
	Note:			
	A higher value produces a flatter gradient and thus a longer search time. A lower value has the opposite effect.			

Parameter list

Par. No.	Name	Range	Default	Unit		
P1210	Automatic restart	0 - 6	1	--		
	Configures automatic restart function					
	Possible Settings:					
	0	Disabled				
	1	Trip reset after power on				
	2	Restart after mains blackout				
	3	Restart after mains brown-/black-out or fault				
	4	Restart after mains brown-/black-out				
	5	Restart after mains blackout and fault				
	6	Restart after mains brown- /black-out or fault				
	Caution:					
	Use caution when setting P1210 ≥ 2. P1210 ≥ 2 can cause the motor to restart automatically without toggling the ON command.					
	Every time when you change the operation mode to the "Motor data setting" mode, the setting of P1210 changes by default to "1". To change the setting, go to the operation mode "Application macro selection" or "Access all the parameters".					
	P1210	ON always active (permanently)		On in no-voltage condition		
		Fault F0003 on		All other faults on		
		Blackout	Brownout	Blackout	Brownout	
		All faults on	No faults on	Blackout	Blackout	
	0	-	-	-	-	
	1	Fault ack.	-	Fault ack.	-	
	2	Fault ack. + restart	-	-	-	Restart
	3	Fault ack. + restart	Fault ack. + restart	Fault ack. + restart	Fault ack. + restart	-
	4	Fault ack. + restart	Fault ack. + restart	-	-	-
	5	Fault ack. + restart	-	Fault ack. + restart	-	Fault ack. Restart
	6	Fault ack. + restart	Fault ack. + restart	Fault ack. + restart	Fault ack. + restart	Restart
	Note:					
	Flying start must be used in cases where the motor may still be turning (for example, after a short mains break) or can be driven by the load (P1200).					
	If P1210 = 4, power brownout will cause the motor to restart, no matter whether the inverter is in LOC or REM mode. In other cases, however, motor restart can only happen when the inverter is in REM mode.					
	Before the operator panel finishes the start course, the setpoint is 1.					
P1215	Holding brake enable	0 - 1	0	--		
	Enables/disables holding brake function.					
	Possible settings:					
	0	Motor holding brake disabled				
	1	Motor holding brake enabled				

Par. No.	Name	Range	Default	Unit
P1216	Holding brake release delay	0.0 - 20.0	1.0	s
	Defines the brake opening time of the motor holding brake. P1216 ≥ Release time of the brake + relay opening time(s)			
P1217	Holding time after ramp down	0.0 - 20.0	1.0	s
	Defines the brake time of the motor holding brake. P1217 ≥ Application time of the brake + relay closing time			
P1230	BI: Enable DC braking	0:0 - 4000:0	0:0	--
	Enable DC braking via a signal applied from an external source. Function remains active while external input signal is active. DC braking causes the motor to stop rapidly by applying a DC braking current (current applied also holds shaft stationary). When the DC braking signal is applied, the inverter output pulses are blocked and the DC current is not applied until the motor has been sufficiently demagnetized.			
	Possible settings:			
	722.0	Digital input 1 (requires P0701 to be set to 99, BICO)		
	722.1	Digital input 2 (requires P0702 to be set to 99, BICO)		
	722.3	Digital input 3 (requires P0703 to be set to 99, BICO)		
	Cautions:			
	With the DC braking, the kinetic energy of the motor is converted into heat in the motor. The drive could overheat if it remains at this status for an excessive time period. DC braking is not possible when using a synchronous motor.			
P1232	DC braking current	0 - 250	100	%
	Defines level of DC current in [%] relative to rated motor current (P0305).			
P1233	Duration of DC braking	0 - 250	0	s
	Defines duration for which DC injection braking is to be active following and OFF1 or OFF3 command. Setting this parameter between 0.01 and 250.00 sets the time duration (in seconds) of the DC injection starting with the OFF1 or OFF3 command.			

Par. No.	Name	Range	Default	Unit
P1236	Compound braking current	0 - 250	0	%

Defines DC level superimposed on AC waveform after exceeding DC-link voltage threshold of compound braking. The value is entered in [%] relative to rated motor current (P0305).

The Compound Brake is an overlay of the DC brake function with regenerative braking (effeteve braking at the ramp) after OFF1 or OFF3. This enables braking with controlled motor frequency and a minimum of energy returned to the motor. Through optimization of the ramp-down time and the compound braking an effective braking without additional HW components is possible.

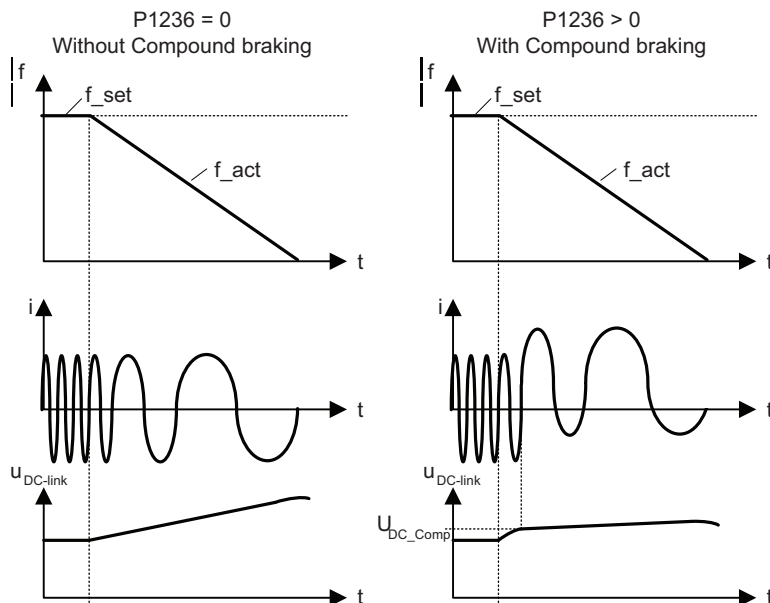

Value:

P1236 = 0	Compound braking is disaled
P1236 = 1...250	Level of DC braking current defined as a [%] of rated motor current (P0305).

Dependency:

Compound braking depends on the DC link voltage only. It will be active with OFF1/OFF3 and at regenerating conditions.

It is disabled when:

- DC braking is active
- Flying start is active

Notice:

Increasing the value will generally improve braking performance; however, if you set the value too high, an overcurrent trip may result. If used with dynamic braking enabled as well compound braking will take priority. If used with the Vdc max. controller enabled the drive behavior while braking may be worsened particularly with high values of compound braking.

P1240	Configuration of Vdc controller	0 - 1	1	--
Enables/disables Vdc controller.				
The Vdc controller dynamically controls the DC link voltage to prevent trips on high inertia systems.				
Possible settings:				
0	Vdc controller disabled			
1	Vdc-max controller enabled			

Par. No.	Name	Range	Default	Unit
P1243	Dynamic factor of Vdc-max	10 - 200	100	%
	Defines dynamic factor for DC link controller in [%].			
	Note: Vdc controller adjustment is calculated automatically from motor and inverter data.			
P1300	Control mode	0 - 2	0	--
	Controls relationship between speed of motor and voltage supplied by inverter.			
	Possible settings:			
	0	V/f with linear characteristic		
	1	V/f with FCC		
	2	V/f with parabolic characteristic		
P1310	Continuous boost	0.0 - 250.0	50.0	%
	P1310 causes a voltage boost depending on the output frequency. At low output frequencies, the output voltage is low to keep the flux level constant. However, the output voltage may be too low			
	<ul style="list-style-type: none"> • for magnetization the asynchronous motor • for hold the load • to overcome losses in the system. 			
P1311	Acceleration boost	0.0 - 250.0	0.0	%
	P1311 will only produce boost during ramping, and is therefore useful for additional torque during acceleration and deceleration.			
P1312	Starting boost	0.0 - 250.0	0.0	%
	Applies a constant linear offset (in [%] relative to P0305 (rated motor current)) to active V/f curve (either linear or quadratic) after an ON command and is active until			
	1) ramp output reaches setpoint for the first time respectively			
	2) setpoint is reduced to less than present ramp output			
	This is useful for starting loads with high inertia.			
	Setting the starting boost (P1312) too high will cause the inverter to limit the current, which will in turn restrict the output frequency.			
P1800	Pulse frequency	2 - 16	4	kHz
	Sets pulse frequency of power switches in inverter. The frequency can be changed in steps of 2 kHz.			
P1910	Select motor data identification	0 - 2	0	--
	Performs a motor data identification.			
	Performs stator resistance measuring.			
	Possible Settings:			
	0	Disabled		
	1	Identification of Rs with parameter change		
	2	Identification of Rs without parameter change		
	Dependency:			
	No measurement if motor data are incorrect.			
	P1910 = 1: Calculated value for stator resistance (see P0350) is overwritten.			
	P1910 = 2: Values already calculated are not overwritten.			
	Note:			
	If the motor data identification routine is activated (e.g. P1910 = 1), then at the next ON command, the measuring operation is started and alarm A0541 is generated. After the measurement is completed, both P1910 and the alarm are reset.			

Parameter list

Par. No.	Name	Range	Default	Unit
P2000	Reference frequency	1.00 - 300.00	50.00	Hz
Parameter P2000 represents the reference frequency for frequency values which are displayed / transferred as a percentage or a hexadecimal value. Where: - hexadecimal 4000 H ⇒ P2000 - percentage 100 % ⇒ P2000 (e.g.: ADC)				
r2036	CtrlWrd1 from operator panel	--	--	--
Displays control word 1 from operator panel (i.e. word 1). Bitfields:				
Bit00	ON/OFF1	0	NO	1 YES
Bit01	OFF2: Electrical stop	0	YES	1 NO
Bit02	OFF3: Fast stop	0	YES	1 NO
Bit03	Pulses enabled	0	NO	1 YES
Bit04	RFG enable	0	NO	1 YES
Bit05	RFG start	0	NO	1 YES
Bit06	Setpoint enable	0	NO	1 YES
Bit07	Fault acknowledge	0	NO	1 YES
Bit08	JOG right	0	NO	1 YES
Bit09	JOG left	0	NO	1 YES
Bit10	Control from the operator panel	0	NO	1 YES
Bit11	Reverse (setpoint inversion)	0	NO	1 YES
Bit13	Motor potentiometer MOP up	0	NO	1 YES
Bit14	Motor potentiometer MOP down	0	NO	1 YES
Bit15	Local / Remote	0	NO	1 YES
Note: The 7-segment display of the bit-parameters (binary parameters) is explained in Fig. 6-12 of Section 6.3.2.				
r2110 [4]	Warning number	--	--	--
Displays warning information. A maximum of 2 active warnings (indices 0 and 1) and 2 historical warning (indices 2 & 3) may be viewed. Index:				
r2110[0]:	Recent warnings - -, warning 1			
r2110[1]:	Recent warnings - -, warning 2			
r2110[2]:	Recent warnings - 1, warning 3			
r2110[3]:	Recent warnings - 1, warning 4			

Par. No.	Name	Range	Default	Unit
P2200	Enable PI controller	0.0 - 2036.F	0.0	--
	Allows user enable/disable the PI controller.			
	Possible settings:			
	0	PI controller deactivated		
	1	PI controller permanently activated		
	52.0	See parameter r0052 for the meaning of individual value settings.		
	...	Note:		
	52.F	The meaning of 52.0 corresponds to the description of Bit00, The meaning of 52.1 corresponds to the description of Bit01, the rest on the analogy of it.		
	722.0	See parameter r0722 for the meaning of individual value settings.		
	...	Note:		
	722.2	The meaning of 722.0 corresponds to the description of Bit00, The meaning of 722.1 corresponds to the description of Bit01, the rest on the analogy of it.		
	2036.0	See parameter r0236 for the meaning of individual value settings.		
	...	Note:		
	2036.F	The meaning of 2036.0 corresponds to the description of Bit00, The meaning of 2036.1 corresponds to the description of Bit01, the rest on the analogy of it.		
	Note:			
	If P2200 = 1, PI feedback = scaled value of ADC output. (For details, see P0757 to P0760.			
P2231	Setpoint memory of PI-MOP	0 - 1	0	--
	Setpoint memory			
	Possible settings:			
	0	PI-MOP setpoint will not be stored		
	1	PI-MOP setpoint will be stored (P2240 is updated)		
	Dependency:			
	If 0 is selected, setpoint returns to the value set in P2240 (setpoint of PI-MOP) after an OFF command			
	If 1 is selected, active setpoint is "remembered" and P2240 is updated with current value.			
	Details:			
	See P2240 (setpoint of PI-MOP)			
P2240	Setpoint of PI	0.00 - 200.00	10.00	%
	Setpoint of the motor potentiometer.			
	Allows user to set a digital PI setpoint in [%].			
	Note:			
	P2240 = 100% corresponds to 4000 hex			
r2262	Filtered PI setpoint after RFG	--	--	%
	Displays the filtered PI setpoint after the PI ramp-function generator (PI_HLG) as percentage.			
r2272	PI scaled feedback	0.00 - 200.00	--	%
	Displays PI scaled feedback signal in [%].			
	Note:			
	r2272 = 100% corresponds to 4000 hex			

Parameter list

Par. No.	Name	Range	Default	Unit
r2273	PI error	--	--	%
	Displays PI scaled error (difference) signal between setpoint and feedback signals in [%].			
	Note: r2273 = 100% corresponds to 4000 hex			
P2280	PI proportion gain	0.000 - 65.000	3.000	--
	Allows user to set proportion gain for PI controller.			
	Note: Default value depends on connection macro selected. See Table 7-11 for details			
P2285	PI integral time	0.000 - 60.000	0.000	s
	Sets integral time constant for PI controller.			
	Note: Default value depends on connection macro selected. See Table 7-11 for details			
P2291	PI output upper limit	-200.00 - 200.00	100.00	%
	Sets upper limit for PI controller output in [%].			
	Dependency: If F max (P1082) is greater than P2000 (reference frequency), either P2000 or P2291 (PI output upper limit) must be changed to achieve F max.			
	Note: P2291 = 100% corresponds to 4,000 hex (as defined by P2000 (reference frequency)).			
P2292	PI output lower limit	-200.00 - 200.00	0.00	%
	Sets lower limit for the PI controller output in [%].			
	Dependency: A negative value allows bipolar operation of PI controller.			
	Note: P2292 = 100% corresponds to 4,000 hex.			
P2293	Ramp-up/-down time of PI limit	0.00 - 100.00	1.00	s
	Sets maximum ramp rate on output of PI.			
	When PI is enabled, the output limits are ramped up from 0% to 100%. Limits prevent large step changes appearing on the output of the PI when the inverter is started. Once the limits have been reached, the PI controller output is instantaneous.			
	These ramp times are used whenever a RUN command is issued.			
	Note: If an OFF1 or OFF 3 are issued, the inverter output frequency ramps down as set in P1121 (ramp-down time) or P1135 (OFF3 ramp-down time). Default value depends on connection mode code selected. See Table 7-11 for details			
r2294	Actual PI output	--	--	%
	Displays PI output in [%]			
	Note: r2294 = 100% corresponds to 4000 hex			

Connection macros dependent default settings

For some parameters, its default value depends on connection macro selected.

Table 7-10 Connection macros dependent default settings

	r0007	P0610	P0701	P0702	P0703	P0725	P1000	P2280	P2285	P2293
C01	C01xx*	1	0	0	0	1	5	3.000	0.000	1.00
C02	C02xx	2	13	14	1	1	1	3.000	0.000	1.00
C03	C03xx	2	1	0	0	1	2	3.000	0.000	1.00
C04	C04xx	2	1	12	0	1	2	3.000	0.000	1.00
C05	C05xx	1	99	1	0	1	2	3.000	0.000	1.00
C06	C06xx	2	1	15	15	1	3	3.000	0.000	1.00
C07	C07xx	2	1	2	0	1	2	3.000	0.000	1.00
C08	C08xx	2	1	2	0	0	2	3.000	0.000	1.00
C09	C09xx	2	1	10	11	1	2	3.000	0.000	1.00
C10	C10xx	2	1	13	14	1	1	0.500	10.000	10.00
C11	C11xx	2	1	12	9	1	5	3.000	0.000	1.00

* 'xx' means current application macro.

Troubleshooting

Acknowledging and clearing fault(s)

In the event of a failure, a fault code appears on the inverter display and the motor stops running.

You can use one of the following three methods to reset the fault code:

- Alternative 1

You can use this alternative if the LOC/REM mode changes are controlled by the operator panel.

To acknowledge and clear a fault, follow these steps:

1. When a fault code appears on the display, press the OK button.
2. Set the current control mode to LOCAL status.
3. Long-press the SET key to go to "Operation mode ⑤ - Access all the parameters (Page 71)" mode.
4. Turn OK to find the fault-specific parameter.
5. Correct wrong parameter setting, then wait till the fault code appears again.
6. Short-press the SET key to clear the fault code. If necessary, you can then set the control mode to REMOTE status.

Note:

1. When C11 is selected, the fault can be acknowledged and cleared via both an external terminal and a BOP.

The figure below shows you an example of these steps:

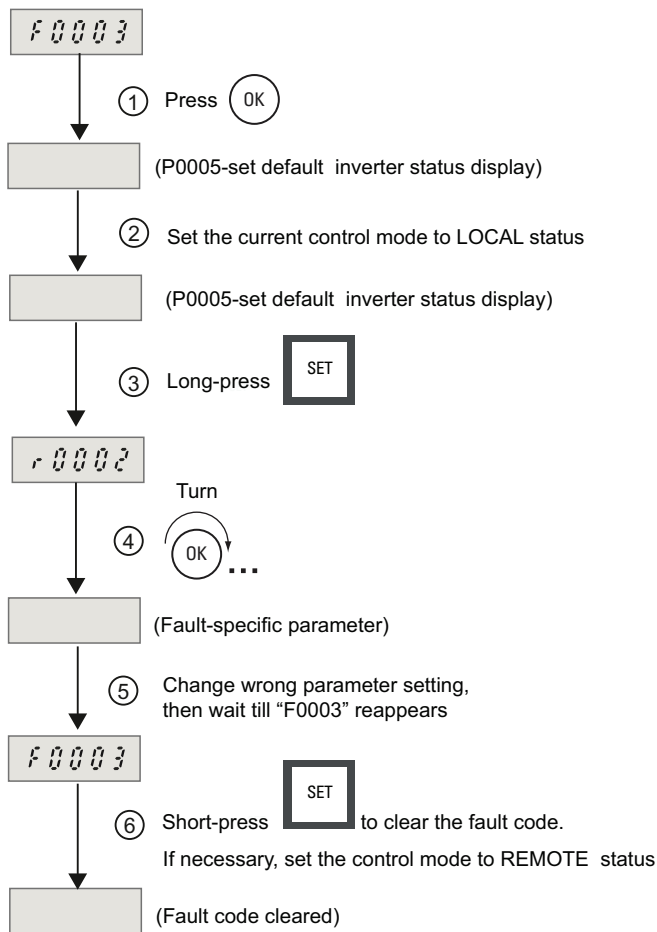

Figure 8-1 Acknowledging and clearing F0003 (example)

- Alternative 2: Re-power on the inverter
- Alternative 3: If a digital input terminal has been configured as the fault clearance terminal via either one of the parameters P0701 to P0703, acknowledge and clear the fault via the digital input terminal.

NOTICE

When multi-faults occur, the fault code is always displayed as x.Fxxx. For example:
 "1.F002" = The first fault code F0002
 "2.F011" = The second fault code F0011
 To view the fault history, go to r0947.

Acknowledging alarm(s)

In the event of an alarm, no key or button is required for acknowledging or clearing the alarm code. After the alarm cause is removed, the alarm code will automatically disappear.

Note

When multi-alarms occur, the alarm code is always displayed as x.Axxx. For example:

"1.A501" = The first alarm code A0501

"2.A503" = The second alarm code A0503

To view the alarm history, go to r2110.

Fault list

Fault	Possible Causes	Diagnose & Remedy
F0001 Overcurrent	<ul style="list-style-type: none"> • Short-circuit at the output • Ground fault • Excessively large motor (the motor power rating P0307 is greater than the inverter power r0206) • Defective final stage (end stage) 	<ul style="list-style-type: none"> • Are the cable lengths within the limit values? • Does the motor cable or motor have either a short-circuit or ground fault? • Do the motor parameters correspond to those of the motor being used? • Is the motor overloaded or stalled (locked rotor)? • Increase the accelerating time. • Reduce the gain (P2280) • Use a motor with a lower power rating • Is the stator resistance value (P0350) correct ?
F0002 Overvoltage	<ul style="list-style-type: none"> • DC link voltage (r0026) higher than the overvoltage threshold (refer to parameter r0026) • Ground fault 	<ul style="list-style-type: none"> • Is the line supply voltage within the permissible range? • Has the DC current DC link monitoring been enabled (P1240) and correctly parameterized? • Extend the deceleration ramp (ramp-down time P1121, P1135) • Remove the ground fault • Is the required braking power within the permissible limits?
F0003 Undervoltage	<ul style="list-style-type: none"> • Line voltage failed • Shock stressing outside the permissible limits 	<ul style="list-style-type: none"> • Is the line supply voltage within the permissible range? • is the line supply voltage stable with respect to sporadic failures and voltage dips (brown-outs)?
F0004 Inverter overtemp.	<ul style="list-style-type: none"> • Inadequate cooling • Ambient temperature is too high 	<ul style="list-style-type: none"> • Is the pulse frequency P1800 set to the factory setting? If required, reset P1800. • Does the ambient temperature lie within the permissible limits? • Reduce the load and / or ensure adequate cooling • Does the fan rotate if the inverter is operational?

Fault	Possible Causes	Diagnose & Remedy
F0005 Inverter I ² T	<ul style="list-style-type: none"> • Inverter overloaded. • Load duty cycle too high. • The motor power rating (P0307) is greater than that of the inverter (r0206). • 100 % overload reached 	<ul style="list-style-type: none"> • Does the load duty cycle lie within the permissible limits? • Use a motor with a lower rating (motor power P0307 is greater than inverter power r0206)
F0011 Motor overtemp. I ² T	Motor overloaded	<ul style="list-style-type: none"> • Is the load cycle correct? • Is the thermal motor time constant (P0611) correct? • Is the motor I²t alarm threshold correct?
F0035 Restart fault after n attempts	P1210 (Automatic restart) is enabled and restart attempts have been conducted for more than three times.	Set P1210 = 0 (Disabled)
F0041 Failure, motor data identification	Motor data identification run unsuccessful	<ul style="list-style-type: none"> • Is the motor connected to the inverter? • Is the motor data in P0304-P0311 correct? • Is motor circuit configuration correct (star, delta configuration)?
F0051 Parameter EEPROM Fault	Read or write operation while saving parameters in the EEPROM was unsuccessful.	<ul style="list-style-type: none"> • Reset to factory setting and then re-parameterize • If the fault remains, contact your local distributor
F0052 Power stack fault	Read error, power data or invalid power module data	Contact your local distributor
F0055 Operator panel EEPROM fault	Read or write failure while saving non-volatile parameter to EEPROM on the operator panel whilst parameter cloning.	<ul style="list-style-type: none"> • Re-upload parameters • Replace the operator panel
F0056 Parameters downloading failed	Fail to download parameters whilst parameter downloading	Re-download the parameters
F0057 Fail to saving parameters into the operator panel	<ul style="list-style-type: none"> • Parameter cloning with empty operator panel • Parameter cloning with invalid operator panel 	<ul style="list-style-type: none"> • Re-upload the parameters into the operator panel • Replace the operator panel
F0058 Incompatible contents saved in the operator panel	Try to do the parameter cloning with the operator panel installed on another type of inverter	<ul style="list-style-type: none"> • Download the parameters from an inverter with the same frame size • Re-configure the settings of motor data, P0611, P0640 and other necessary parameters
F0060 Asic time slice overflow	Internal communication failure/error	Contact your local distributor
F0070 Internal communication error 1	No setpoint was received internally	Contact your local distributor
F0071 Internal communication error 2	No setpoint was received	Contact your local distributor

Fault	Possible Causes	Diagnose & Remedy
F0072 Inverter communication error	The inverter in LOC control mode has lost communication with the operator panel for a minimum of two seconds. If the communication loss happens in REM control mode, the inverter will not output F0072 fault code.	<ul style="list-style-type: none"> • Check the physical connection between the inverter and operator panel • If the fault remains, contact your local distributor
F0080 Analogue input - lost input signal	<ul style="list-style-type: none"> • Broken wire • Signal out of limits 	Check connection to analogue input
F0085 External Fault	External fault is triggered via terminal inputs	Disable terminal input for fault trigger
F0101 Stack overflow	Software error or processor failure	Restart the inverter
F0221 PI feedback below minimum value	PI feedback below 0 %	<ul style="list-style-type: none"> • Adjust feedback gain • Adjust ACD parameter setting
F0222 PI Feedback above maximum value	PI feedback above 200%	Adjust feedback gain
F0422 No load applied to inverter	No load is applied to the inverter. As a result, some functions may not work as under normal load conditions.	Apply the load
F0450 BIST tests unsuccessful	<ul style="list-style-type: none"> • Self-test routine for power module components unsuccessful • Several function tests were unsuccessful • Failure of the internal RAM at the switch-on test 	<ul style="list-style-type: none"> • The inverter is functional, but several functions are not correctly executed. • If the fault remains, contact your local distributor
F0999 Inverter initialization unsuccessful	<ul style="list-style-type: none"> • Poor wiring • Internal communication between inverter operator panel and the body unit not yet established 	Power off the inverter, then check wiring. Power on the inverter again after troubleshooting.

Alarm list

Alarm codes are stored in parameter r2110 and can be readout from there.

Alarm	Possible causes	Diagnose & Remedy
A0501 Current limit value	<ul style="list-style-type: none"> The motor power rating does not correspond to the inverter power rating Motor cables are too long Ground fault 	<ul style="list-style-type: none"> Does the motor power rating (P0307) match the inverter power rating (r0206)? Are the limit values for the cable lengths maintained? Does the motor cable or motor have a short-circuit or ground fault? Do the motor parameters correspond to those of the motor being used? Stator resistance value (P0350) correct? Is the motor overloaded or is the rotor locked (cannot rotate)? Ramp-up time P1120 too low
A0502 Overvoltage limit value	The overvoltage limit value has been reached (The actual value of the DC link voltage r0026 exceeds limit)	<ul style="list-style-type: none"> Is the DC link voltage controller (Vdc_max controller) de-activated (refer to parameter P1240)? Short ramp times and/or large flywheel masses (moment of inertia)?
A0503 Undervoltage Limit	<ul style="list-style-type: none"> Line supply has failed. Line voltage and therefore also the DC link voltage (r0026) below the defined limit value (refer to parameter r0026). 	Check supply voltage (P0210)
A0504 Inverter overtemperature	Alarm threshold of the inverter heatsink temperature was exceeded. This results in a reduction of the pulse frequency and/or the output frequency (dependent on the parameterization in (P0610).	<ul style="list-style-type: none"> Is the ambient temperature within the permissible limits? Are the load and load duty cycle within the permissible limits?
A0505 Inverter I ² T	<ul style="list-style-type: none"> Overload alarm limit P0294 is exceeded (refer to utilization r0036) The pulse frequency and/or the output frequency is reduced as a function of the setting of parameter P0290. 	Decrease inverter duty cycle
A0506 Inverter duty cycle	Heatsink temperature and thermal junction model are outside of allowable range	Check if duty cycle is within specified limits
A0511 Motor overtemperature I ² T	<ul style="list-style-type: none"> Motor overloaded load duty cycle is exceeded 	Is P0611(motor I2t time constant) value setting suitable?
A0541 Motor data identification active	Motor data identification (P1910) selected or running	Wait until motor identification is finished
A0571 Auto restart after fault present	Auto restart function already activated	Check the setting of P1210
A0600 RTOS data loss alarm	Time slice overflow was identified	

Alarm	Possible causes	Diagnose & Remedy
A0700 ... A0711 Internal communication error	-	Contact your local distributor
A0910 Vdc-max controller disabled/switched-out	<ul style="list-style-type: none"> Line supply voltage is permanently too high Motor is driven by an active load, which means that the motor goes into regenerative operation Decelerating (short down-ramps P1121) for extremely high load torques 	Are load duty cycle and load limits within the permissible limits?
A0911 Vdc-max controller active	<ul style="list-style-type: none"> Vdc max controller is active The ramp-down times are automatically increased in order to keep the DC link voltage (r0026) within the limit values (Refer to r0026 and P1240). 	<ul style="list-style-type: none"> Check parameter inverter input voltage Check ramp-down times
A0912 Vdc-min controller active	<ul style="list-style-type: none"> Vdc min controller is activated, if the DC link voltage (r0026) falls below the minimum value, refer to r0026 or P1240) The kinetic energy of the motor is used to buffer the DC link voltage and therefore to slow down the drive. Therefore brief line failures no longer automatically result in an under voltage trip. 	<ul style="list-style-type: none"> Check parameter inverter input voltage Check ramp-up times
A0920 ADC parameters not set properly	ADC parameters should not be set to identical values, since this would produce illogical results.	Analogue input parameters should not be set to the same value as each other
A0921 DAC parameters not set properly	DAC parameters (P0777 vs. P0779 or P0778 vs. P0780) have identical values. Identical values would produce illogical results.	<ul style="list-style-type: none"> Output parameter settings. Ensure P0777 and P0779 are not identical. Input parameter settings. Ensure P0778 and P0780 are not identical.
A0922 No load applied to inverter	<ul style="list-style-type: none"> No load is applied to the inverter As a result, some functions may not work as under normal load conditions. 	<ul style="list-style-type: none"> Check that a load is applied to the inverter Check motor parameters concerned
A0923 Both JOG Left and JOG Right are requested	Both JOG Left and JOG Right have been requested. This freezes the RFG output frequency at its current value. JOG right and JOG left signals active together	Make sure that JOG right and JOG left signals are not applied simultaneously.

Technical data

Table 9-1 Technical specifications - SINAMICS V10 inverter

Order no.:	Frame Size A	Frame Size B	Frame Size C	Frame Size D										
6SL3217-0CE														
15-5 UA1	17- 2 2 UA1	22-2 UA1	23-0 UA1	24-0 UA1	25-5 UA1	27-5 UA1	31-1 UA1	31-5 UA1	31-8 UA1	32-2 UA1				
	5	1 1												
	UA	- -												
	1	1 5												
		U U												
		A A												
		1 1												
Display	5-digit, 7-segment LCD													
Configurable motor	3-ph AC asynchronous squirrel cage motors													
Electrical data														
Rated motor power (kW)	0.55	0.75	1.1	1.5	2.2	3.0	4.0	5.5	7.5	11	15	18.5	22	
Rated input current (A)	1.9	2.4	3.7	5.2	6.5	8.6	11.6	15.6	22.0	32.3	38.5	47.1	56.3	
Rated output current (A)	1.7	2.2	3.1	4.1	5.9	7.7	10.2	13.2	18.4	26.0	32.0	38.0	45.0	
Output current derat-ings with pulse freq. changes	Pulse freq.	Range: 2 to 16 kHz; Default PWM: 4 kHz The max. continuous output current (A) at different pulse frequencies is shown as below: ¹⁾												
	2 kHz	1.7	2.2	3.1	4.1	5.9	7.7	10.2	13.2	18.4	26.0	32.0	38.0	45.0
	4 kHz	1.7	2.2	3.1	4.1	5.9	7.7	10.2	13.2	18.4	26.0	32.0	38.0	45.0
	6 kHz	1.7	2.2	3.1	4.1	5.9	7.7	10.2	13.2	18.4	26.0	27.2	32.3	38.3
	8 kHz	1.7	2.2	2.7	2.7	5.1	5.1	6.7	13.2	13.2	17.9	22.4	26.6	31.5
	10 kHz	1.7	2.2	2.7	2.7	5.1	5.1	6.7	13.2	13.2	17.9	19.2	22.8	27.0
	12 kHz	1.7	1.6	1.6	1.6	3.6	3.6	4.8	9.6	9.6	13.5	16.0	19.0	23.2
	14 kHz	1.7	1.6	1.6	1.6	3.6	3.6	4.8	9.6	9.6	13.5	14.4	17.1	20.3
	16 kHz	1.1	1.1	1.1	1.1	2.6	2.6	3.6	7.5	7.5	10.4	12.8	15.2	18.0
Mains operating voltage	Rated: 3 AC 400 V (tolerance: - 15 % to + 15 %)													
Mains input frequency	Rated: 50 Hz (tolerance - 3% to + 3%) Full frequency range: 48 Hz to 52 Hz													
Mains system	TNC, TNS, TT or IT systems ²⁾													
Output frequency	0 Hz to 300 Hz If output frequency is less than 2 Hz for over 0.5 s, the default switching frequency shall be reduced to half of the default value.													
Power factor	0.95													
Inverter efficiency	96 % to 97 %													
Overload capability	150% of the rated output current for 60 s; Cycle time: 300 s													

Technical data

Order no.:	Frame Size A	Frame Size B	Frame Size C	Frame Size D		
6SL3217-0CE						
Overvoltage category	Mains input terminals (L1, L2, L3): III Digital output terminals (DO1) ³⁾ : II, max. 250 V In accordance with IEC 61800-5-1					
Pollution class	II, in accordance with IEC 61800-5-1					
Noise level	< 80dB for the whole product family					
Control method	Linear V/f control; Quadratic V/f control; V/f control with Flux Current Control (FCC)					
Fixed frequency	3, programmable					
Skip frequency:	1					
Setpoint resolution	0.01 Hz digital input					
Digital inputs	3, programmable (isolated)					
Analog input	1, programmable (0 to 10 V or 0 to 20 mA)					
Relay output	1, programmable, 250 V AC / max. 2 A (inductive), 30 V DC / max. 5 A (resistive)					
Analog output	1, programmable (0 to 10 V or 0 to 20 mA, max. 500 ohm in current mode / min. 5000 ohm in voltage mode)					
Braking	DC braking, compound braking					
Protection functions	① Short circuit protection ② Over-current protection ③ Over-/Under-voltage protection ④ Inverter and motor over-temperature protections ⑤ Ground fault protection ⑥ Stall prevention ⑦ Motor blocking protection ⑧ Parameter interlock					
Max. Motor cable length	Without choke	Unshielded	50 m	50 m	100 m	100 m
		Shielded	30 m	30 m	50 m	50 m
	With choke	Unshielded	100 m	100 m	200 m	250 m
		Shielded	60 m	60 m	100 m	150 m
Mechanical data						
Outline dimensions (mm)	H	230	260	331	401	
	W	140	150	218	260	
	D ⁴⁾	155 (138)	159 (142)	203 (186)	223 (210)	
Note: The outline dimensions of the operator panel are 91 x 97 x 30 (H x W x D, in mm).						
Weight (kg) ⁵⁾	2.2	2.9	8.1	10.1		
Mounting method	For inverter with assembled operator panel: <ul style="list-style-type: none"> • Wall mounting without optional mounting kit • Push-through mounting with optional mounting kit For removable operator panel: <ul style="list-style-type: none"> • Mounted to cabinet door 					
Cooling method	Natural cooling	Forced cooling	Forced cooling	Forced cooling	Forced cooling	
Environmental conditions						

Order no.:	Frame Size A	Frame Size B	Frame Size C	Frame Size D
6SL3217-0CE				

Ambient temperature Operation 0 °C to 50 °C without power derating (100 % load)
 50 °C to 60 °C with power derating

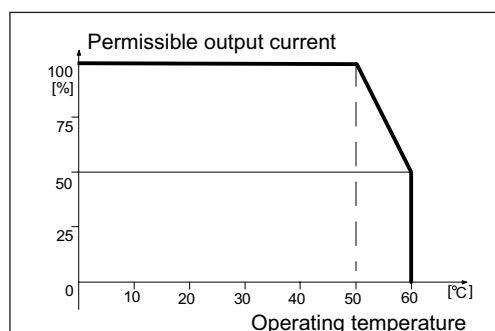

Inverter derating with increased operating temperature

Transport & storage	-40 °C to + 70 °C
---------------------	-------------------

Relative humidity	5 to 95 %, without condensation
-------------------	---------------------------------

Contamination level	Chemical gases: 3C2 and solid particles: 3S2, according to IEC60721-3-3
---------------------	-------------------------------------------------------------------------

Vibration resistance	< 1 G (9.81 m/s ²) acceleration
----------------------	---------------------------------------------

Atmospheric pressure	0 to 1, 000 m above sea level: without power derating 1,000 m to 4,000 m: with power derating ⁶⁾
----------------------	----------------------------------------------------------------------------------------------------------------

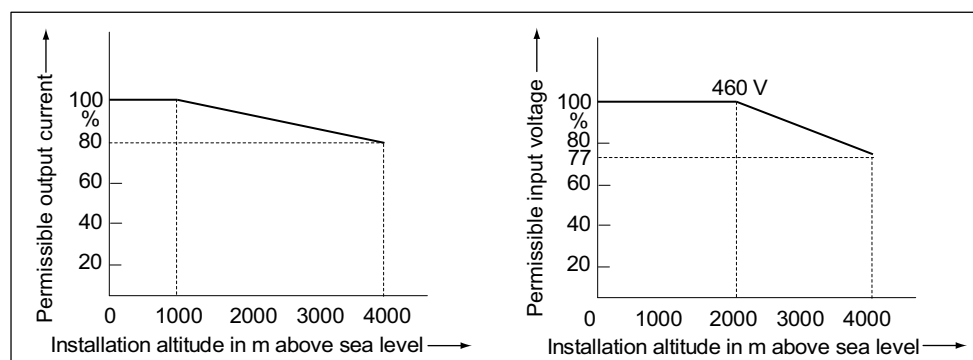

Inverter derating with increased altitude ⁷⁾

Protection class	IP21 (excluding all input/output terminals) ⁸⁾
------------------	-----------------------------------------------------------

Standards	CE mark, in accordance with Low-Voltage Directive 2006/95/EC;
-----------	---------------------------------------------------------------

- 1) Unless otherwise specified, the output current indicated refers to the value that can be reached when the ambient temperature is at 50 °C.
- 2) Can be operated on TNC, TNS, TT or IT, excluding three-phase three-wire systems unearthed or corner-earthed; Can also be operated on the three-phase three-wire systems unearthed or corner-earthed if an appropriate transformer or a separately derived source that normally supplies an unearthed system is installed on the mains system.
- 3) The digital output terminals are at a dangerously high voltage when Non-SELV control voltage is applied. Use only approved double insulated cable for supply connection with nominal cross-section area of at least 0.75 mm²/ 300 V / 75 °C and protected by max. 6A external fuse, type gG approved based on IEC 60269.
- 4) The depth value in brackets refers to the value of the inverter without the operator panel.
- 5) The weight here includes the weight of the operator panel.

- 6) If the mounting altitude reaches 2000 m or above, it's necessary to mount an isolating transformer.
- 7) The permissible output current is specified in % of the rated output current. The permissible input voltage is specified in % of the max. mains input voltage.
- 8) The protection class of all input/output terminals is IP00.

NOTICE

If customers use external 24 V power supply, the range of this power supply should be from DC19.6V to DC28.8V. For detailed wirings, please refer to connection modes in Typical connection modes (Page 39).

Replacing the fans

A

There are two fans preassembled on Frame Size B, Frame Size C and Frame Size D respectively. When replacing the fan, proceed the procedure shown below.

Removing the fans from Frame Size B

Follow the steps described in the figure to remove the fans from Frame Size B:

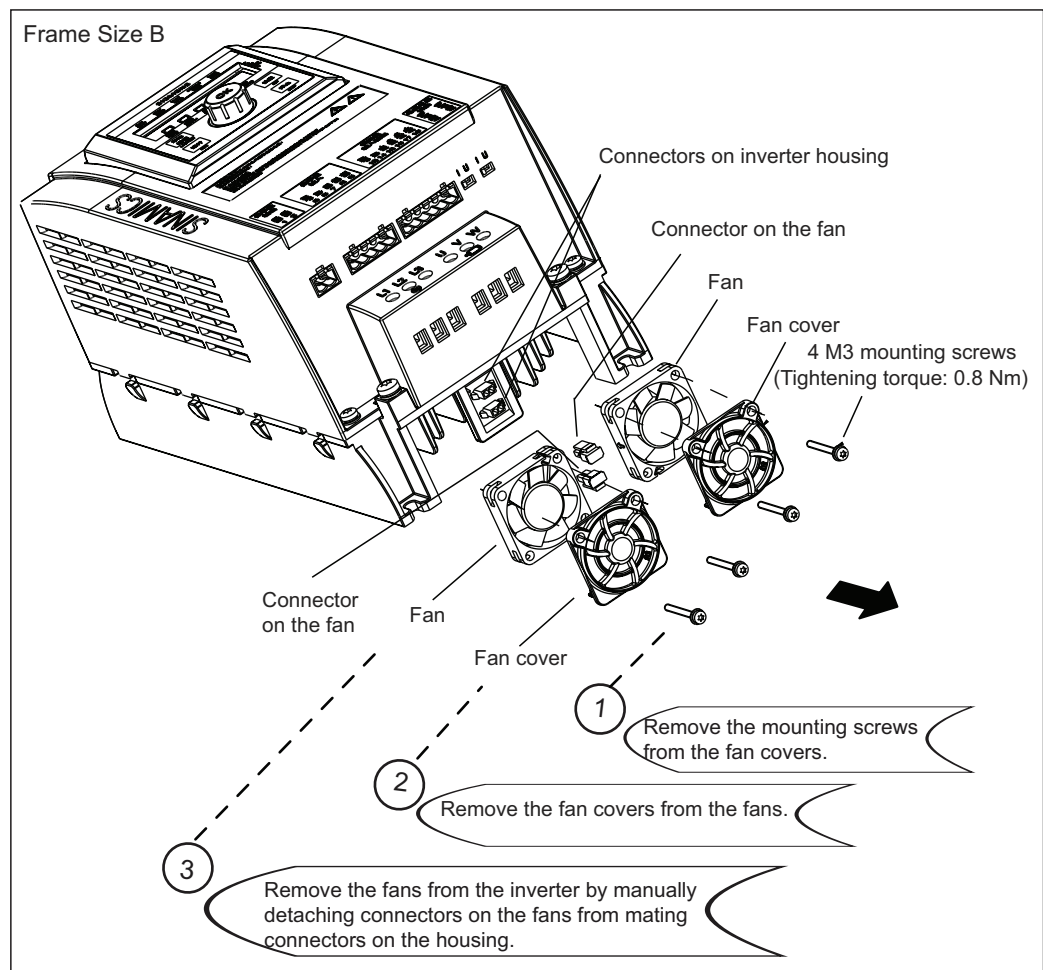

Figure A-1 Removing the fans from Frame Size B

Removing the fans from Frame Size C

Follow the steps described in the figure to remove the fans from Frame Size C:

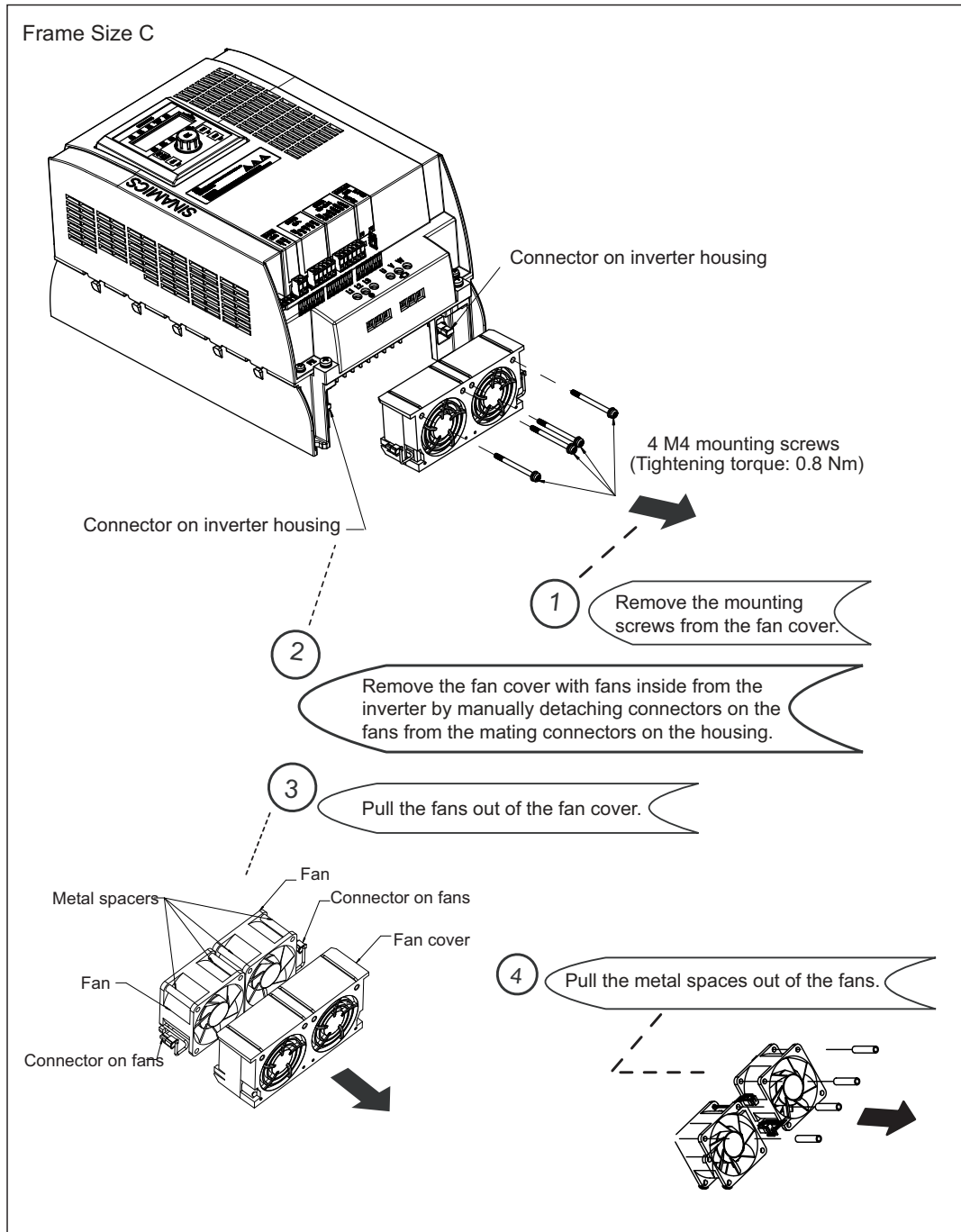

Figure A-2 Removing the fans from Frame Size C

Removing the fans from Frame Size D

Follow the steps described in the figure to remove the fans from Frame Size D:

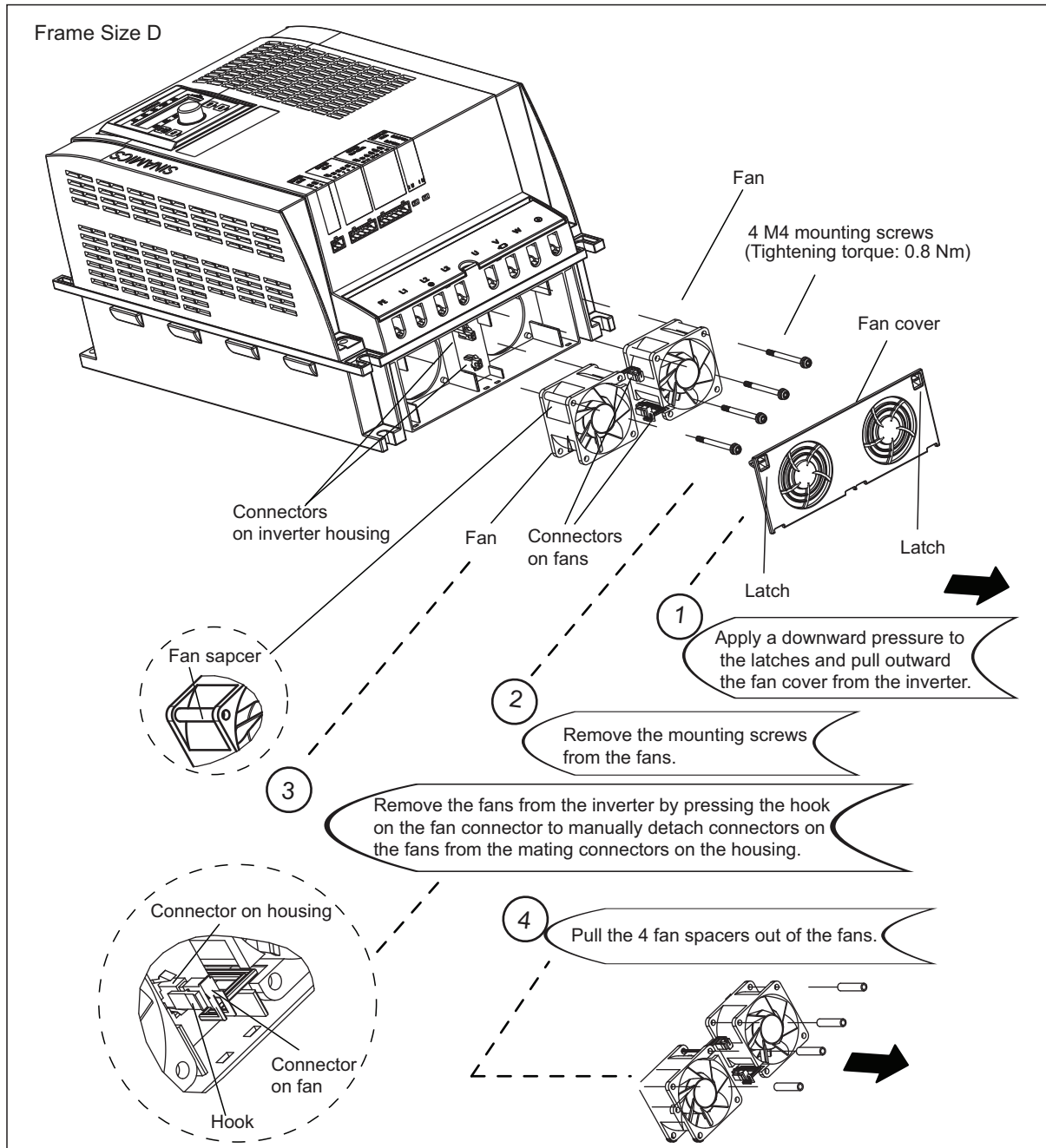

Figure A-3 Removing the fans from Frame Size D

Index

C

Commissioning

- Access all the parameters (example), 71
- Application macro selection, 69
- Application macros, 56
- clone a parameter, 73
- Common application macro specific parameter setting, 70
- Factory reset (P0970), 72
- Inverter status display, 65
- LOC, 59
- MOP-down, 42
- MOP-up, 42
- Parameters related to application macros, 56
- Quick motor data setting, 66
- REM, 59
- Setting an indexed parameter, 71
- typical connection modes, 39
- Viewing a normal read-only parameter, 71

D

Delivery

- Inverter MLFB (order number) explanation, 16
- Inverter rating plate, 16
- Options, 17
- Rating plate on the rear of the operator panel, 17
- Scope of delivery, 15
- Spare parts, 19

E

Electrical installation

- Conductor cross-sections of the DI/DO, AI/AO terminal connecting cable, 36
- Conductor cross-sections of the mains input cable and the motor output cable, 35
- Interfaces between inverter body unit and the remote operator panel, 35
- Layout of interfaces other than PE terminals, 34
- PE terminal layout, 33
- Power and motor connections, 37

M

Mechanical installation

- Mounting clearance, 22
- Mounting orientation, 21
- Mounting the operator panel to cabinet door, 32
- Push-through mounting, 25
- Wall mounting, 23

P

Parameter list

- Flying start, 97
- OFF1, 78
- OFF2, 78
- OFF3, 78

T

Troubleshooting

- Acknowledging alarm(s), 109
- Acknowledging and clearing fault(s), 107
- Alarm list, 112
- Fault list, 109

