

Intelligent Drivesystems, Worldwide Services



**SK 2x5E**

Decentralised drive technology  
for conveyor technology





# Power and function for conveyor technology

## Absolute and relative positioning with POSICON

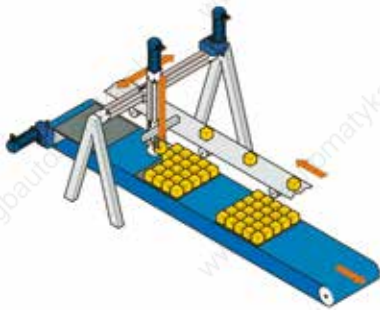

### Servo mode



## Energy-saving function

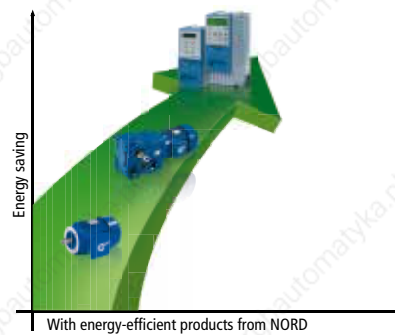

## Lifting gear functions

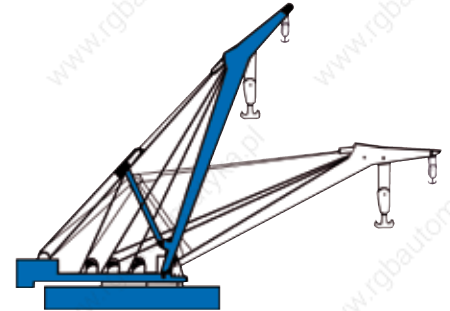

## Safety function "Safe stop"



## Frequency inverters are now

standard components for conveyor system drive units. They not only regulate speeds, they also manage complex control and drive regulating functions as well as provide safety functions and contribute to saving valuable energy resources.

The SK 2x5E combines all of these characteristics in a single integrated unit, which can be located near to or directly on the drive unit. The advantages of this are obvious: The drive unit and its integrated control can be pre assembled by NORD and delivered as a complete unit (up to IP66).

This not only reduces installation and commissioning costs but also does away with the need for long motor cables. Control cabinets are no longer necessary, or can be reduced in size. Control cabinet cooling systems to dissipate the heat produced by frequency inverters and brake resistors are not required and the inverter can be located in explosion hazard areas (ATEX Zone 22). Even completely autonomous operation with just a mains cable is feasible. Interfaces for most common bus systems can be easily implemented for more sophisticated applications.



**NORD is your partner for planning, commissioning and service.**

With NORD drive technology we can provide the optimum solution for all requirements.

# Power and function for conveyor technology

Your advantage	Implemented with
Universal application	<ul style="list-style-type: none"> <li>- Mains voltages, 1~115V, 1/3~ 230V or 3~500V</li> <li>- Robust devices for use in harsh environments IP55 / IP66, Climate Class 3K4 and 3M7 (vibration)</li> <li>- Versions available for operation in ATEX Zone 22 Category 3D</li> </ul>
Simple to use, fast and convenient commissioning	<ul style="list-style-type: none"> <li>- Interface for the connection of display, parameterisation and control elements</li> <li>- Connection of supply and control cables via an easily accessible connection unit on the frequency inverter</li> </ul>
Wide range of functions	<ul style="list-style-type: none"> <li>- High precision speed regulation even at low frequencies (from 1 Hz according to the size of motor)</li> <li>- Speed feedback with optional HTL incremental encoder for speeds above 0 Hz with full load take-up</li> <li>- POSICON positioning control</li> <li>- Brake control for mechanical holding brake</li> <li>- Connection of brake resistors for dissipating high brake powers</li> <li>- Connection of switches and sensors via digital inputs and outputs)</li> </ul>
Safe operation with comprehensive monitoring	<ul style="list-style-type: none"> <li>- High overload reserves up to 200%</li> <li>- Diagnostic facility via status LEDs and error memory</li> <li>- Thermistor input for reliable monitoring of motor temperature</li> <li>- Integrated digital output for reporting operating states and limiting values</li> <li>- Safety functions STO and SS1 can be implemented</li> </ul>
Modification to individual requirements	<ul style="list-style-type: none"> <li>- Optional field bus modules (Profibus, EtherCat, etc.)</li> <li>- Optional I/O extension for additional control cables (Control signal to FI, feedback from FI)</li> <li>- Master – Slave operation of inverters (e.g. for synchronous operation of drives in parallel) via integrated system bus</li> </ul>
Environmental protection	<ul style="list-style-type: none"> <li>- Reduction of energy and operating costs through standard "Automatic flux optimisation" function (see page 8)</li> <li>- Interference suppression via integrated Class A (C2) mains filter</li> </ul>
High system availability	<p>Short standstill times and reduced risk of assembly errors thanks to:</p> <ul style="list-style-type: none"> <li>- Extensive, optional range of plug connectors for power and control cables</li> <li>- Attachment to the motor with only 4 screws</li> <li>- Inverter replacement without reprogramming through plug-in EEPROM memory module</li> </ul>

# Basic equipment for SK 205E conveyor technology

SK 2x5E power range:  
1~115 V – 3~500 V  
0.25 - 7.5 kW



## SK 205E basic equipment:

- ✓ Sensorless current vector control (ISD)
- ✓ Plug-in memory storage module (EEPROM)
- ✓ PTC input
- ✓ Status LEDs for digital inputs
- ✓ Brake control (rectifier integrated)
- ✓ 2 setpoint potentiometers
- ✓ Immediate-access RS 232 diagnostic interface
- ✓ Energy-saving function
- ✓ Incremental encoder evaluation
- ✓ POSICON positioning control

## Control signals

### 4 digital inputs

e.g. for left/right release, fixed frequencies or switching over of parameters



### 1 Digital output

e.g. reporting of errors or various limit values

## External 24V supply



### Connection for external 24V power supply

Separate voltage levels for power and control, e.g. for separate commissioning or online availability when the power is switched off.

## Control of electro-mechanical brake



### Integrated one-way rectifier

Application and release time optimally adjustable with parameter.

# Basic requirements for drive technology

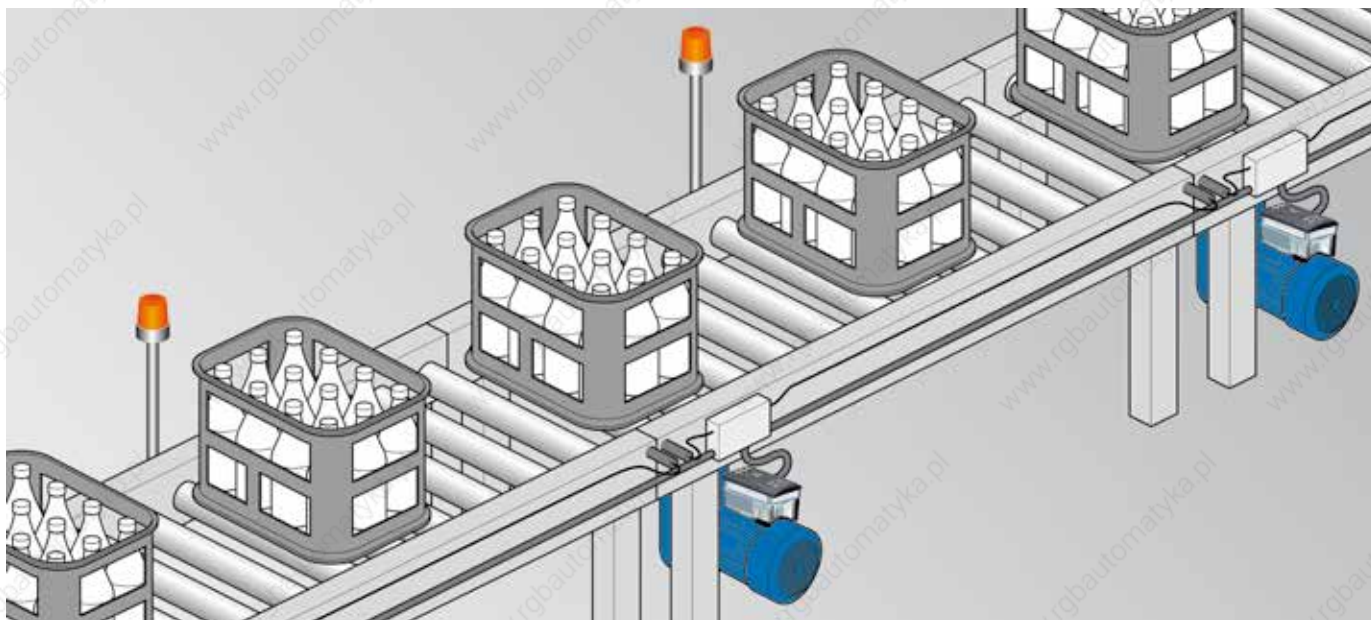

Requirement	Solution with NORD technology
Decentralised drive technology	Wide range of gear motors with frequency inverters which are integrated into or mounted close to the motor
Frequency inverters	SK 2x5E with matching connection unit (see page 8/9)
Wall-mounting kit or adapter kit for motor mounting	Wall-mounting kit SK TIE-WMK-x, up to IP 66 (see page 10) (NB: derating by up to 3 power classes is possible) Wall-mounting kit SK TIE-WMK-L, IP 55 with fan (see page 10) Motor-mounting: adapter kit may be required (see BU 0200)
Large adjustment range	50Hz characteristic curve: Inverter power class = Motor power class 87Hz characteristic curve: The power class of the inverter is up to two power classes greater than that of the motor (motor 230 V, inverter 400V)
Thermal monitoring of motor	Thermistor input integrated into the FI

## Advantages of 87Hz characteristic curve:

With a constant torque, both the speed and the power of the motor can be increased beyond the rated values. This results in a greater adjustment range > 1:17.

$$1.73 < \frac{\text{inverter power}}{\text{nominal motor power}}$$



# SK 2x5E, typical equipment features for horizontal drive solutions



Requirement	Solution with NORD technology	Option (Part No.)
<b>Solution for very simple applications with constant speeds</b>		
Variable, but usually constant speed, right/left/stop	24V mains unit (for installation in the FI) and switch/poti-adapter for installation on the frequency inverter	SK CU4-24V-...(see F 3020) SK CU4-POT (275271207)
Feedback of operating status	Integrated digital output	
<b>Solution of horizontal applications with increased dynamics (rapidly changing speeds) and increased speed precision</b>		
Constant speed, even with load fluctuations and low speeds (from 0 Hz)	Incremental encoder on the motor shaft with connection cable	IG KU 10-30V HTL 2048 D12 1.5m (19551011)
Increased dynamics	Integrated brake resistor	SK BRI4-...(see page 10)
Control via analog and digital I/O via external PLC or	I/O extension with connection unit for installation on the frequency inverter	SK TU4-IOE (275281106) and SK TI4-TU-BUS (275280000)
Control via field bus system such as Profibus, EtherCat, etc. (instead of switch or potentiometer adapter)	E.g.: optional Profibus module with connection unit for installation on the frequency inverter	SK TU4-PBR (275281106) and SK TI4-TU-BUS (275280000)

# SK 215E / SK 235E the frequency inverters for very highest precision



Requirement	Solution with NORD technology	Option (Part No.)
Constant speed with full load takeover from speed "zero" and/or precise positioning	Combined encoder (absolute encoder with incremental track) on the motor shaft with M12 connector and connection cable	AG&IG CANopen-8192/4096/2048 HTL D12 (19551886), AG connection cable (18909996) IG connection cable (18909995)
Very high dynamics or large amounts of (brake) energy feedback	External brake resistor SK BRE4-...	SK BRE4-...(see page 10)
Control of an electro-mechanical holding brake	Integrated brake relay with automatic brake control	
Functional safety (Safety Category STO or SS1)	Integrated in SK 215E / SK 235E	
Control via field bus system such as Profibus, EtherCat, etc. (instead of switch or potentiometer adapter)	E.g.: Profibus module with connection unit for installation on the frequency inverter	SK TU4-PBR (275281106) and SK TI4-TU-BUS (275280000)



## SK 2x5E versions 3~ 400V / 50Hz

SK 205E with extensive basic equipment		✓ IP 55	
3~ 400 V / 50Hz P in kW	Part number frequency inverter	Designation frequency inverter	Part number connection unit
0.55	275222305	SK 205E-550-340-A	275270100
0.75	275222306	SK 205E-750-340-A	275270100
1.10	275222307	SK 205E-111-340-A	275270100
1.50	275222308	SK 205E-151-340-A	275270100
2.20	275222309	SK 205E-221-340-A	275270100
3.00	275222310	SK 205E-301-340-A	275270101
4.00	275222311	SK 205E-401-340-A	275270101
5.50	275222312	SK 205E-551-340-A	275270102
7.50	275222313	SK 205E-751-340-A	275270102

SK 225E with efficient bus system		✓ AS interface on board ✓ IP 55	
3~ 400 V / 50Hz P in kW	Part number frequency inverter	Designation frequency inverter	Part number connection unit
0.55	275224305	SK 225E-550-340-A	275270120
0.75	275224306	SK 225E-750-340-A	275270120
1.10	275224307	SK 225E-111-340-A	275270120
1.50	275224308	SK 225E-151-340-A	275270120
2.20	275224309	SK 225E-221-340-A	275270120
3.00	275224310	SK 225E-301-340-A	275270121
4.00	275224311	SK 225E-401-340-A	275270121
5.50	275224312	SK 225E-551-340-A	275270122
7.50	275224313	SK 225E-751-340-A	275270122

As the default setting, all frequency inverters are pre-configured for the operation of a 4-pole standard motor of the relevant power class with the 50Hz characteristic curve.





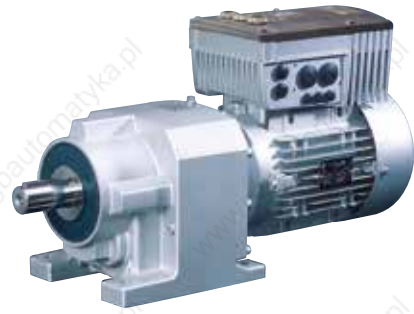

**SK 215E**  
with safety technology

- ✓ Safety function "Safe stop"
- ✓ IP 55

3~ 400 V / 50Hz P in kW	Part number frequency inverter	Designation frequency inverter	Part number connection unit
0.55	275223305	SK 215E-550-340-A	275270110
0.75	275223306	SK 215E-750-340-A	275270110
1.10	275223307	SK 215E-111-340-A	275270110
1.50	275223308	SK 215E-151-340-A	275270110
2.20	275223309	SK 215E-221-340-A	275270110
3.00	275223310	SK 215E-301-340-A	275270111
4.00	275223311	SK 215E-401-340-A	275270111
5.50	275223312	SK 215E-551-340-A	275270112
7.50	275223313	SK 215E-751-340-A	275270112

**SK 235E** with safety technology  
and efficient bus system

- ✓ Safety function "Safe stop"
- ✓ AS interface on board
- ✓ IP 55

3~ 400 V / 50Hz P in kW	Part number frequency inverter	Designation frequency inverter	Part number connection unit
0.55	275225305	SK 235E-550-340-A	275270130
0.75	275225306	SK 235E-750-340-A	275270130
1.10	275225307	SK 235E-111-340-A	275270130
1.50	275225308	SK 235E-151-340-A	275270130
2.20	275225309	SK 235E-221-340-A	275270130
3.00	275225310	SK 235E-301-340-A	275270131
4.00	275225311	SK 235E-401-340-A	275270131
5.50	275225312	SK 235E-551-340-A	275270132
7.50	275225313	SK 235E-751-340-A	275270132

For further versions see  
brochure F 3020



# Options

<p><b>Flush-mounted switches / potentiometers</b></p> <ul style="list-style-type: none"> <li>• SK TIE4-SWT IP66, (Part No. 275 274 701)</li> <li>• SK TIE4-POT IP66, (Part No. 275 274 700)</li> </ul>	
<p><b>Maintenance switch</b></p> <ul style="list-style-type: none"> <li>• SK TU4-MSW IP55, (Part No. 275 281 123)</li> <li>• SK TU4-MSW-C IP66, (Part No. 275 281 173)</li> </ul>	
<p><b>ParameterBox (Full-text display in 12 languages)</b></p> <ul style="list-style-type: none"> <li>• SK PAR - 3H Handheld (Part. No. 275 281 014)</li> <li>• SK PAR - 3E Control cabinet installation (Part. No. 275 281 414)</li> </ul>	
<p><b>External and internal brake resistor 400V</b></p> <ul style="list-style-type: none"> <li>• 0.55kW - 2.2kW Internal resistor (Part. No. 275 272 012)</li> <li>• 3.0kW - 7.5kW External resistor (Part. No. 275 273 012)</li> <li>• 0.55kW - 2.2kW Internal resistor (Part. No. 275 272 108)</li> <li>• 3.0kW - 7.5kW External resistor (Part. No. 275 273 108)</li> </ul>	
<p><b>Wall-mounting</b></p> <p>up to 4 kW</p> <ul style="list-style-type: none"> <li>• SK TIE4 WMK-L-1 IP55, (Part No. 275 274 005)</li> </ul> <p>up to 7.5kW</p> <ul style="list-style-type: none"> <li>• SK TIE4 WMK-L-2 IP55, (Part No. 275 274 006)</li> </ul>	
<p><b>Profibus</b></p> <ul style="list-style-type: none"> <li>• SK TU4-PBR IP55, (Part No. 275 281 100 and 275 280 000)</li> <li>• SK TU4-PBR-M12 IP55, (Part No. 275 281 200 and 275 280 000)</li> </ul>	

For further options see  
brochure F 3020

# Enquiry form

Company	_____	Tel.:	_____
Street	_____	Fax:	_____
Postcode, Town and Country	_____	E-mail	_____

Gear motors			
Number of poles	<input type="radio"/> 2	<input type="radio"/> 4	<input type="radio"/> 6
Voltage			
Power			
Protection class	<input type="radio"/> IP 55	<input type="radio"/> IP 66	
Mounting	<input type="radio"/> Foot	<input type="radio"/> Flange	
Torque			
Type of gear unit			
Speed ratio			
Number			

SK 2x5E part number:		
Phases	<input type="radio"/> 1	<input type="radio"/> 3
Voltage		
Power		
Protection class	<input type="radio"/> IP 55	<input type="radio"/> IP 66
Mounting	<input type="radio"/> Motor mounted	<input type="radio"/> Wall mounted
Number		

Options		
<input type="radio"/> Profibus	<input type="radio"/> Profibus 24V	
<input type="radio"/> DeviceNet		
<input type="radio"/> CANopen		
<input type="radio"/> I/O extension		
Mounting of option	<input type="radio"/> Mounted on SK 2x5E	<input type="radio"/> Wall mounted

Option	
<input type="radio"/> PotentiometerBox	
<input type="radio"/> Poti-Adapter	
<input type="radio"/> ParameterBox Handheld	
<input type="radio"/> ParameterBox control cabinet installation	
<input type="radio"/> SimpleBox Handheld	
<input type="radio"/> SimpleBox control cabinet installation	
<input type="radio"/> SetpointBox	
Number	

System connectors		
<input type="radio"/> Power 3~ In		
<input type="radio"/> Power 3~ In/Out		
<input type="radio"/> Motor output		
<input type="radio"/> M12 for initiators	No.	
<input type="radio"/> M12 for bus system		

All connections for power cables, bus systems and control signals can be equipped with system plug connectors.





[www.nord.com/locator](http://www.nord.com/locator)

**Headquarters:**

**Getriebebau NORD GmbH & Co. KG**

Rudolf-Diesel-Straße 1

22941 Bargteheide, Germany

Fon +49 (0) 4532 / 289-0

Fax +49 (0) 4532 / 289-2253

info@nord.com, www.nord.com

**Member of the NORD DRIVESYSTEMS GROUP**

