

Magnetic rotary angle and position sensor-control.

Contactless sensor. MTS-360

Options.

- Special outputs slopes and protocols.
- Full redundant version with switches.
- Energy harvesting versions.
- Fast versions.
- Connectors.
- IP sealing.
- Shaft interfaces.
- Contact the factory for other options.

Dimensions.

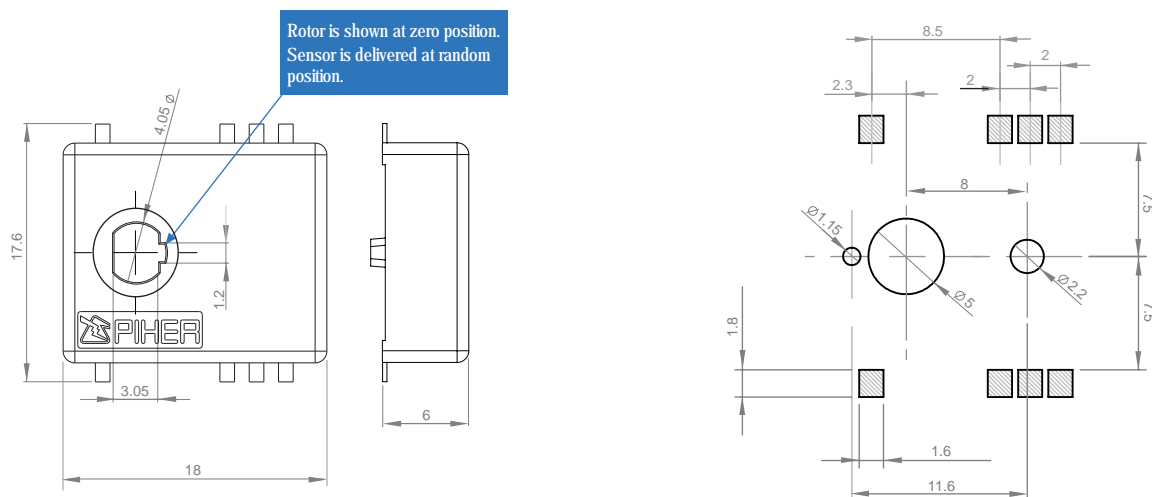

Recommended shaft.

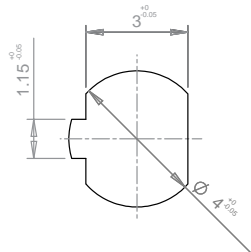

Piher Sensors & Controls

Our product competencies and services:
Potentiometers | [Position / angle sensors](#) | Rotary switches | Incremental encoders
Printed circuit resistors | Mechatronics | Value added assemblies

Magnetic rotary angle and position sensor-control.

Contactless sensor. MTS-360

Mounting instructions.



Electronic semiconductor products are sensitive to Electro Static Discharge (ESD).

Always observe Electro Static Discharge control procedures whenever handling semiconductor products.

Recommended reflow profile.

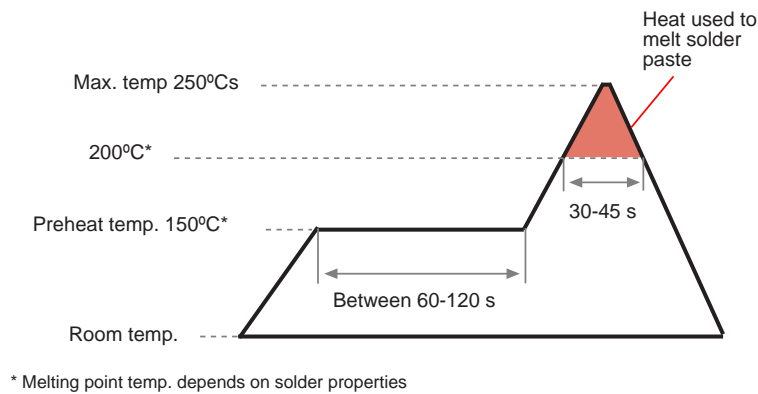

The recommended reflow profile is provided as a guideline. Optimal profile may differ due to oven type, assembly layout or other design or process variables. Customers should verify actual device performance in their specific application and reflow process. Please contact Piher if you require additional support.

Connections scheme.

Simple analog output version connection scheme.

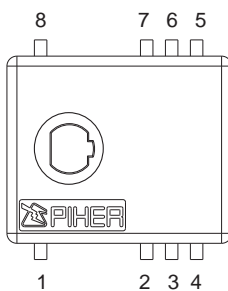

Pin	Description
1	Supply voltage
2	Supply voltage
3	Switch output*
4	Switch output*
5	Signal output**
6	Signal output**
7	Ground
8	Ground

* If the feature is not used in the application, please connect to ground

** Piher can supply the recommended wiring diagram

Piher Sensors & Controls

Our product competencies and services:
Potentiometers | [Position / angle sensors](#) | Rotary switches | Incremental encoders
Printed circuit resistors | Mechatronics | Value added assemblies