

VQ600 Datasheet

Pellistor Gas Sensor for Hazardous Areas (Fixed Systems)

The VQ600 Series is designed to detect and monitor various gases in the range 0 to 100% LEL for combustible gases and 0 to 100% volume in thermal conductivity mode when using the SGX range of pellistor gas sensors.

The VQ600 Series is designed for use as an integral part of a fixed gas detection system. The head comprises a stainless steel flameproof enclosure constructed with an integral stainless steel sinter which allows the safe entry of the atmosphere being tested.

There are three types of mounting thread available to allow easy fixing to the junction box of the fixed system and the facility to attach accessories to the sensor via an external M46 thread.



FEATURES

- Designed for fixed gas detection systems
- For detection of the following:
 - Combustible gases (Catalytic Sensors)
 - Light gases (e.g. hydrogen and helium). (Thermal Conductivity Sensors)
- LEL and % Volume Monitoring
- Diffused gas sampling via sinter
- Three thread options available
- Operational in varying temperature, pressure and humidity
- Fast response
- Rugged stainless steel construction
- No moving parts
- Resistance to corrosion
- Low maintenance
- Accessories available for field applications
- ATEX certified
- CSA certified (Canada and US)

The head must be mounted so that the cable is protected. This is normally achieved by mounting it into a port in a suitable junction box.

Although SGX generally recommends that pellistors should be run with a constant voltage supply to the bridge, it is possible to use a constant current supply provided that the voltage across the bridge in clean air remains within the recommended limits.

It is essential that the head be efficiently earthed (grounded). This may be achieved by mounting it either into an earthed metal junction box, or into a non-metallic junction box fitted with an earth continuity plate used in accordance with the box manufacturer's instructions. There are no internal connections to the sensing head body.

TECHNICAL SPECIFICATION

Mechanical

Dimensions	See Outline on Page 4
Body material	Stainless Steel
Weight	435g

Environmental

Ambient temperature range for operation (ATEX):	-20°C to +60°C
for operation (CSA):	-20°C to +65°C
storage:	-20°C to +60°C
Operational pressure range	700kPa to 1300kPa
Humidity range for operation and storage	0 to 100% RH (Non-condensing)
Gases Detected	Combustible, Light Gases

Electrical

DC supply to detectors	See Configurations Table on Page 2
Typical power	Refer to Pellistor Type Datasheet



OPERATION

The pellistor used in the head should be operated in the manner recommended in the appropriate data sheet. In general it is recommended that the detector and compensator be run in a Wheatstone Bridge circuit so that a difference signal may be obtained. A suitable circuit is shown in Fig. 1.

In use, the bridge supply voltage should not be allowed to vary by more than the specified +0.1 V, or the output in clean air may change in sympathy.

Whilst SGX has taken care to ensure the accuracy of the information contained herein it accepts no responsibility for the consequences of any use thereof and also reserves the right to change the specification of goods without notice. SGX accepts no liability beyond the set out in its standard conditions of sale in respect of infringement of third party patents arising from the use of SGX products in accordance with information contained herein. In case of modification of the product, SGX disclaims all liability.

CONFIGURATIONS

Base Sensor Type	Pellistor Type (See Note 1)	Operating Voltage (V) (See Note 3)	Typical Current (mA)	Type	Thread Code (See Table Below)			Gas Types
					1	2	3	
601	VQ1B	2.0	300	Catalytic	Yes	Yes	Yes	All Flammable Gases
603	VQ3B	2.5	330	Catalytic	Yes	Yes	Not Available (See Note 2)	All Flammable Gases
605M	VQ5MB	2.0	175	Thermal Conductivity	Yes	Not Available (See Note 2)	Not Available (See Note 2)	Light Gases (e.g. H ₂ , He ₂)
606M	VQ6MB	2.0	300	Thermal Conductivity	Yes	Not Available (See Note 2)	Yes	Light Gases (e.g. H ₂ , He ₂)
621T	VQ21TB	2.0	300	Catalytic	Yes	Yes	Yes	All Flammable Gases
621TS	VQ21TSB	2.0	300	Catalytic	Yes	Not Available (See Note 2)	Yes	All Flammable Gases
622T	VQ22TB	2.0	175	Catalytic	Yes	Yes	Yes	All Flammable Gases
623	VQ23TB	2.5	335	Catalytic	Yes	Not Available (See Note 2)	Not Available (See Note 2)	All Flammable Gases
625	VQ25B	2.0	300	Catalytic	Yes	Yes	Yes	Most Flammable Gases (Not including Methane)
631M	VQ31MB	3.5	90	Thermal Conductivity	Yes	Yes	Yes	Light Gases (e.g. H ₂ , He ₂)
635M	VQ35MB	4.2	55	Thermal Conductivity	Yes	Yes	Yes	Light Gases (e.g. H ₂ , He ₂)
641TS	VQ41TSB	2.0	100	Catalytic	Yes	Not Available (See Note 2)	Yes	Most Flammable Gases (Not including Methane)

Note 1: Refer to the datasheet for each Pellistor Type for more information.

Note 2: If the desired Thread Type is listed as "Not Available" please contact SGX.

Note 3: Thermal Conductivity sensors can be operated at voltages different to stated above depending upon target gas type.

THREAD CODES

The sensing head is supplied with one of three different mounting threads at the user's choice (see outline on Page 4).

Thread code	Thread	Dimension X (mm)
1	Metric 20 x 1.5 mm	16.00
2	ANP (Taper) 1/2" - 14 NPT	19.85
3	ANP (Taper) 3/4" - 14 NPT	20.16

Taper threads are manufactured in accordance with ANSI/ASME B1.20.1.

OPERATING CIRCUIT

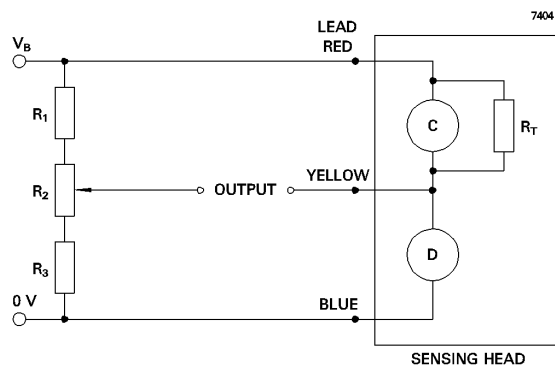

$$R_1 = R_3 = 500 \text{ to } 5000 \Omega, R_2 \cong R_1/5$$

R₂ provides zero adjustment and may be omitted if not required.