

Specifications

Ver.1.1

Product Name

PIR MOTION SENSOR "PaPIRs"

Model No.

EKMB119111□

Page: 1

1. Product Name

PIR MOTION SENSOR "PaPIRs"

WL series • Slight motion detection type (1μA / Digital output)

2. Model Number

Lens Color	Model Number
White	EKMB1191111
Black	EKMB1191112
Pearl White	EKMB1191113

3. Dimensions

Top VIEW

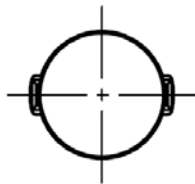

Side VIEW

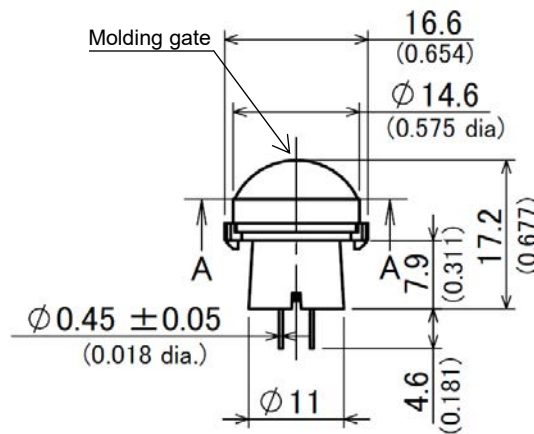

Bottom VIEW

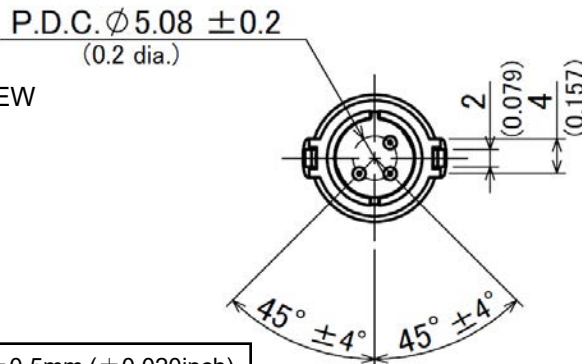

Marking

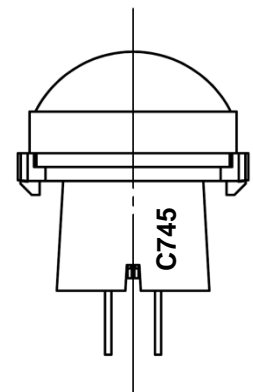

C 7 45

a) b) c)

a) The Marking which was shown by a list shown below

Marking	Model Number
A	EKMC169111□
B	EKMB139111□K
C	EKMB119111□
D	EKMB129111□
E	EKMB269111□
F	
G	EKMC269111□K
H	EKMC469111□K
I	
J	
K	

b) Last-digit of the year
(Ex:2017=7,2018=8,...)

c) Lot No.
1st week of Jan. will be 01,
and further No. of 02,03,
will continue up to 53.

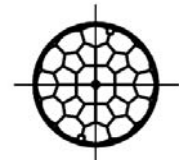

SECTION A-A

General Tolerance ±0.5mm (±0.020inch)

Panasonic Corporation

Approved by

Checked by

Issued on Mar. 29th,2018

Designed by

Specifications

Ver.1.1

Product Name

PIR MOTION SENSOR "PaPIRs"

Model No.

EKMB119111□

Page: 2

4.Characteristics

4-1 Detection Performance

Conditions for measuring: Ambient temperature=25°C(77° F) Operating voltage=3VDC

	Temperature difference	Value	Conditions concerning the target
(Note1) Detection Range	8°C(14.4° F)	Max 3.5m	1.Movement speed: 0.5m/s 2.Target concept is human head (Object size:Around 200×200mm)
	4°C(7.2° F)	Max 2.5m	

Note1:Depending on the temperature difference between the target and the surroundings, detection range will change.

		Value	Notes
Detection Area	Horizontal	97° (±48.5°)	Refer to the section 4-5.
	Vertical	97° (±48.5°)	
	Detection zones	112	

4-2 Maximum Rated Values

	Value	Unit
Power Supply Voltage	-0.3~4.5	VDC
Usable Ambient Temperature	-20~+60°C (-4~+140° F) Do not use in a freezing or condensation environment	
Storage Temperature	-20~+70°C (-4~+158° F)	

4-3 Electrical Characteristics

Conditions for Measuring: Ambient temperature=25°C(77° F)

	Symbol	Min	Avg.	Max	Unit	Special mention
Operating Voltage	Vdd	2.3	—	4.0	VDC	—
Electrical Current Consumption (Sleep mode)	Iw	—	1.0	1.6	μA	Iout=0
Electrical Current Consumption (Standby mode)	Iw	—	1.9	3.0	μA	Iout=0
Output Current	Iout	—	—	100	μA	Vout≥Vdd-0.5
Output Voltage	Vout	Vdd-0.5	—	—	VDC	—
Circuit Stability Time (when voltage is applied)	Twu	—	25	210	s	—

※For more information about the sleep mode or the standby mode please refer to entry 4-5.

Issued on Mar. 29th,2018

Panasonic Corporation

(SKC0410-P01.02,140701)