

Description

The FS1012 MEMS mass flow sensor module measures the flow rate using the thermo-transfer (calorimetric) principle. The FS1012 is capable of measuring a gas or liquid medium.

The FS1012 offers key advantages over resistor-based flow solutions. The sensor utilizes thermopile sensing, which provides an excellent signal-to-noise ratio. The sensor comprises a “solid” thermal isolation technology and silicon-carbide coating to protect it from abrasive wear and provides robustness and long-term reliability. In comparison, other sensors typically contain a fragile membrane above an etched cavity for the thermal isolation base.

The FS1012 features the sensor fully assembled and wire-bonded out to a 6-pin header.

Features

- Gas or liquid mediums
- Robust “solid” isolation technology
- Resistant to surface contamination
- No cavity to cause clogging
- Resistant to vibration and pressure shock
- Low power application
- Sensitive at low flow rates and differential pressure levels
- Fast response: 2ms
- Millivolt output
- Supply voltage: 3V to 5V
- Module operating temperature range: 0°C to +85°C

Typical Applications

- Process controls and monitoring
- Oil and gas leak detection
- HVAC and air control systems
- CPAP and respiratory devices
- Automotive mas air flow meter
- Liquid dispensing system

FS1012 Flow Sensor Module

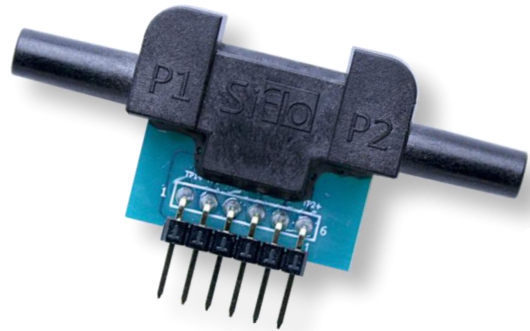

Basic Application Circuits

Figure 1. Single-Ended Circuit Example

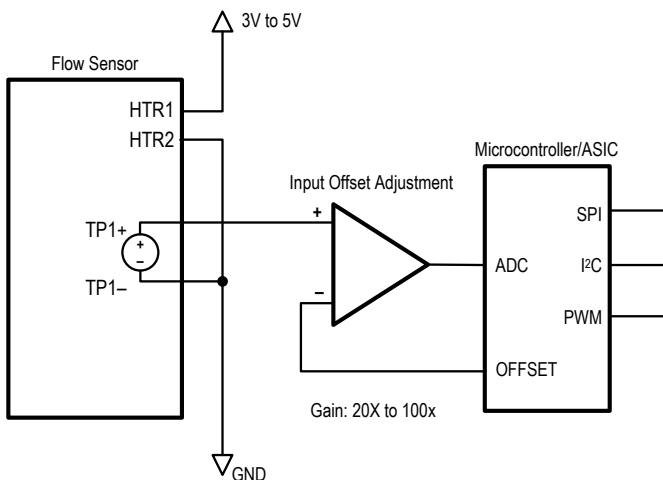
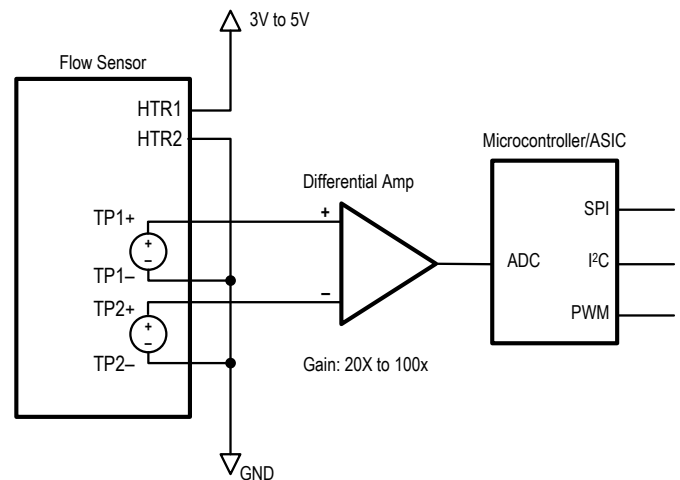
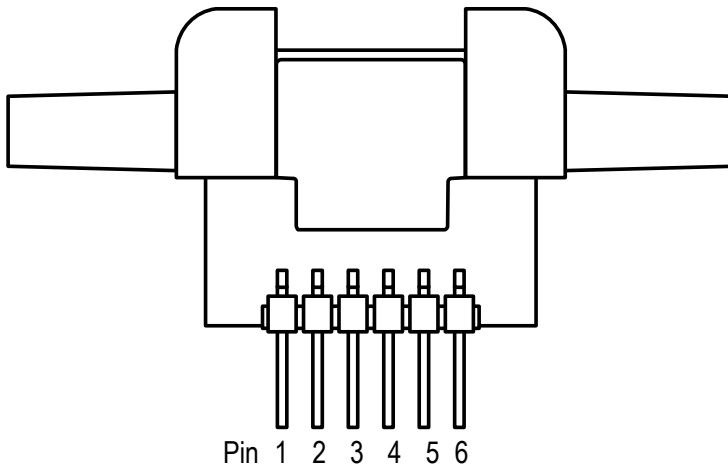

Figure 2. Differential Circuit Example



Pin Assignments

Figure 3. Pin Assignments for Module – Top View



Pin Descriptions

Table 1. Pin Descriptions

Pin Number	Pad Name	Type	Description
1	TP1+	Output	Thermopile 1 (+)
2	TP1-	Output	Thermopile 1 (-)
3	HTR1	Input	Heater
4	HTR2	Input	Heater
5	TP2-	Output	Thermopile 2 (-)
6	TP2+	Output	Thermopile 2 (+)