

Oferta sprzedaży centrum obróbczego do metalu TAKUMI V11A



Spis treści

| | |
|----------------------------------|----|
| OFERTA CENOWA..... | 3 |
| Oferta | 3 |
| Warunki gwarancji | 3 |
| Dodatkowe informacje | 3 |
| OPIS MASZINY..... | 4 |
| Informacje podstawowe | 4 |
| Elementy układu napędowego | 4 |
| Stół roboczy | 4 |
| Wrzeciono | 4 |
| Osie i zakresy..... | 4 |
| Narzędzia..... | 5 |
| Wyposażenie maszyny | 5 |
| Waga i wymiary | 5 |
| Załączniki do oferty..... | 7 |
| Zdjęcia maszyny..... | 7 |
| Accuracy test chart..... | 14 |

OFERTA CENOWA

Oferta

| Lp. | Nazwa towaru/usługi | Cena netto (PLN) | Ilość | Wartość netto (PLN) | Vat | Wartość brutto (PLN) |
|-----|------------------------------|------------------|-------|---------------------|-----|----------------------|
| 1 | Centrum obróbcze Takumi V11A | 99000,00 | 1 | 99000,00 | 23% | 121770,00 |

Warunki gwarancji

Gwarancja na podzespoły elektroniczne maszyny : 12 miesięcy

Gwarancja na element mechaniczne : 3 miesiące

Dodatkowe informacje

Na życzenie klienta :

- organizujemy transport maszyny do dowolnego miejsca w Europie.
- przeprowadzamy szkolenie
- wykonujemy próbny detal na podstawie dostarczonej specyfikacji

OPIS MASZYNY

Informacje podstawowe

| | |
|-------------------------|---------------------------|
| Typ maszyny: | Frezarka |
| Liczba osi: | 3 |
| Rodzaj stołu roboczego: | Łoże |
| Rodzaj sterowania: | CNC MITSUBISHI MELDAS 500 |
| Rok produkcji: | 1997 |

Elementy układu napędowego

| | |
|------------------|---------------------------------|
| Napęd osi X i Y: | MDS-C1-V2-2020 2kW MITSUBISHI |
| Napęd osi Z: | MDS-C1-V2-20 2kW MITSUBISHI |
| Napęd wrzeciona: | MDS-C1-SP-185 18,5kW MITSUBISHI |
| Zasilacz: | MDS-C1-CV-220 22kW MITSUBISHI |

Stół roboczy

| | |
|---|------------|
| Wymiary stołu roboczego(długość x szerokość): | 1350x510mm |
| Maksymalna waga detalu: | 800kg |
| Szerokość/ilość/odległość rowków teowych: | 18x5x100mm |

Wrzeciono

| | |
|--------------------------------|----------------------------------|
| Ilość wrzecion: | 1 |
| Orientacja wrzeciona: | Pionowa |
| Maksymalna prędkość wrzeciona: | 6000obr/min - przekładnia pasowa |
| Moc wrzeciona: | 7,5Kw (10HP) |

Osie i zakresy

| | | |
|------------------|------------|---------------------------------|
| Prędkość obróbki | 6000mm/min | |
| Liczba osi: | 3 | |
| | Zakres | Prędkość przyspieszonego posuwu |
| x1 | 1100mm | 12000mm/min |
| y1 | 550mm | 12000mm/min |
| z1 | 650mm | 12000mm/min |

Narzędzia

| | |
|--------------------------------|---|
| Rodzaj magazynu narzędzi: | ATC - automatyczna zmieniarzka narzędzi |
| Ilość narzędzi: | 24 |
| Maksymalna długość narzędzia: | 300mm |
| Maksymalna średnica narzędzia: | 80mm |
| Maksymalna waga narzędzia: | 8kg |
| Uchwyt narzędzia: | CAT-40 |

Wyposażenie maszyny

| | |
|-----------------------------------|-------------------------------|
| Oświetlenie stołu | Chłodzenie szafy sterowniczej |
| Lampa informująca o pracy maszyny | Chłodnica wrzeczona |
| Przenośny panel sterowniczy MPG | Transformator |

Waga i wymiary

| | |
|--|-------------|
| Wymagane miejsce: | 3650x3350mm |
| Waga maszyny: | 6500kg |
| Odległość końcówki wrzeczona od powierzchni stołu: | 150-800mm |
| Odległość wrzeczona od prowadnicy pionowej: | 550mm |

Precyzyjne wymiary maszyny zostały przedstawione są na poniższych grafikach

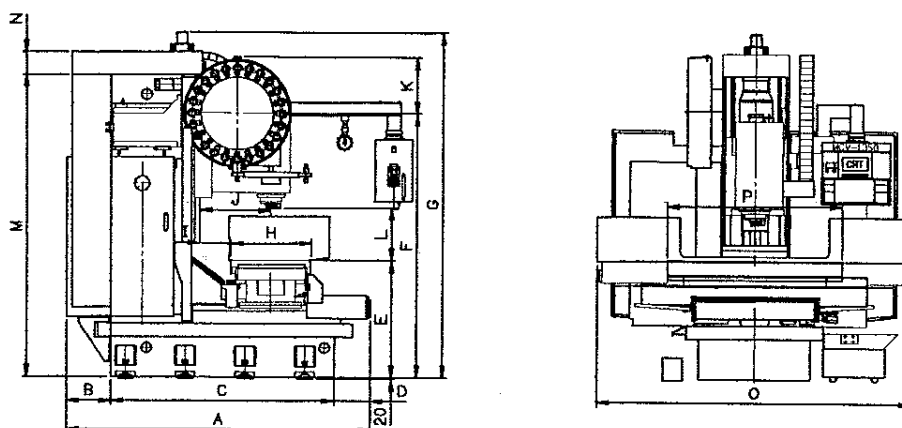

| TYPE | A | B | C | D | E | F | G | H | I | J | K | L | M | N | O | P |
|---------|------|-----|------|-----|-----|------|------|-----|-----|-----|-----|---------|------|-----|------|------|
| V 8 (A) | 2156 | 201 | 1610 | 345 | 750 | 1340 | 2354 | 510 | 295 | 550 | 530 | 150-710 | 2354 | - | 1944 | - |
| V11 (A) | 2340 | 340 | 1720 | 280 | 900 | 2020 | 2645 | 510 | 295 | 550 | 430 | 150-780 | 2315 | 155 | 2420 | 1350 |

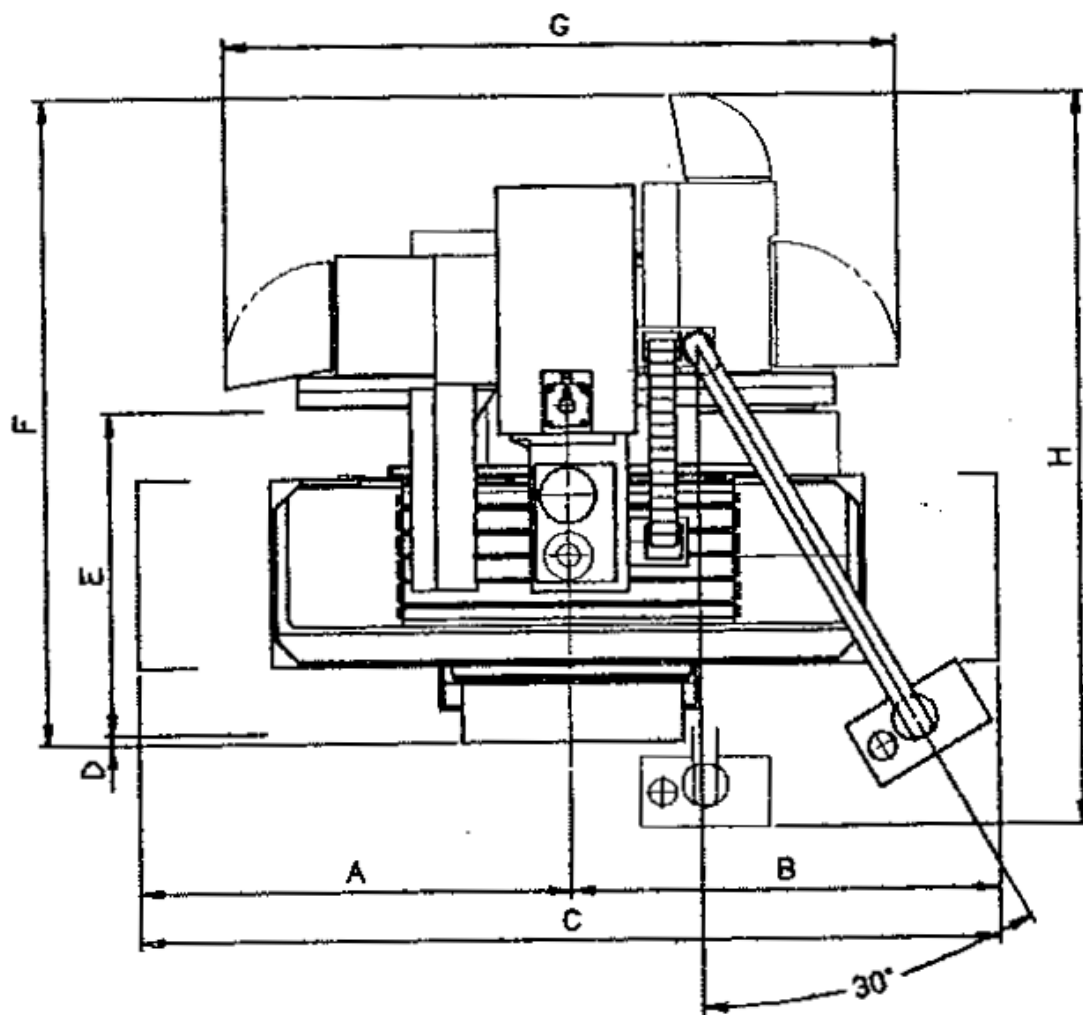

| TYPE | A | B | C | D | E | F | G | H |
|---------|------|------|------|----|------|------|------|------|
| V 8 (A) | 1450 | 1450 | 2900 | 40 | 1120 | 2646 | 2754 | 3220 |
| V11 (A) | 1765 | 1765 | 3530 | 45 | 1220 | 2700 | 2800 | 3000 |

Załączniki do oferty

Zdjęcia maszyny











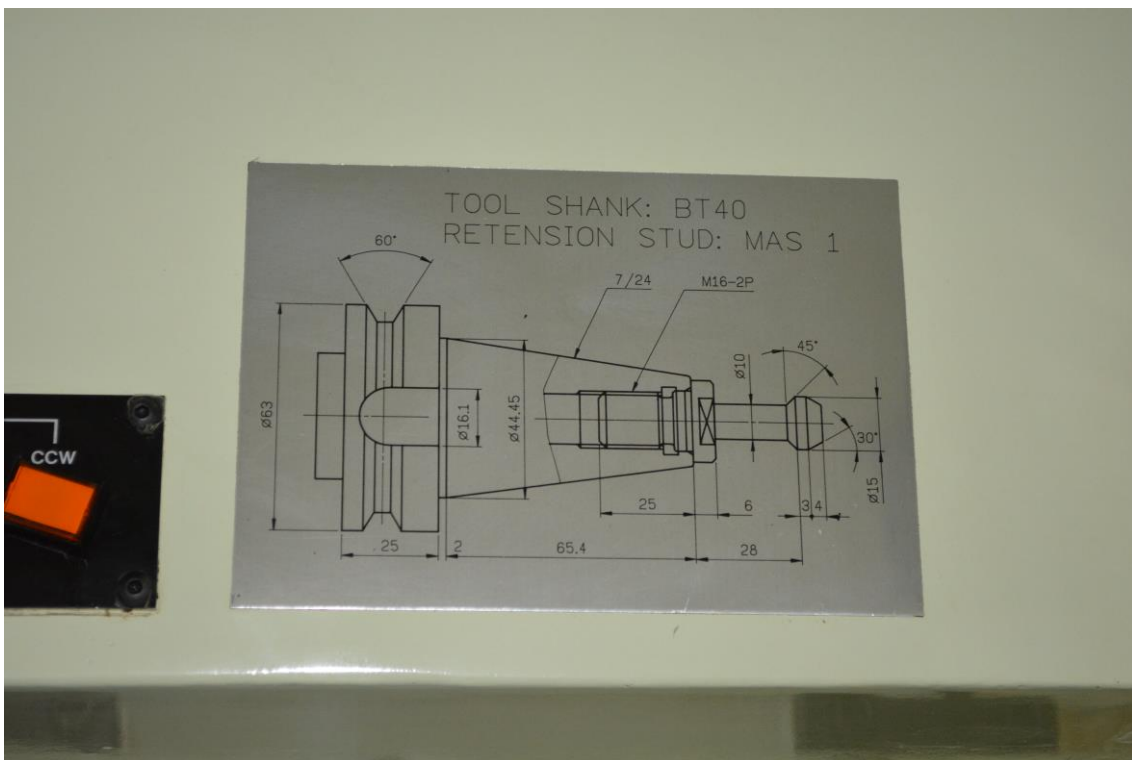
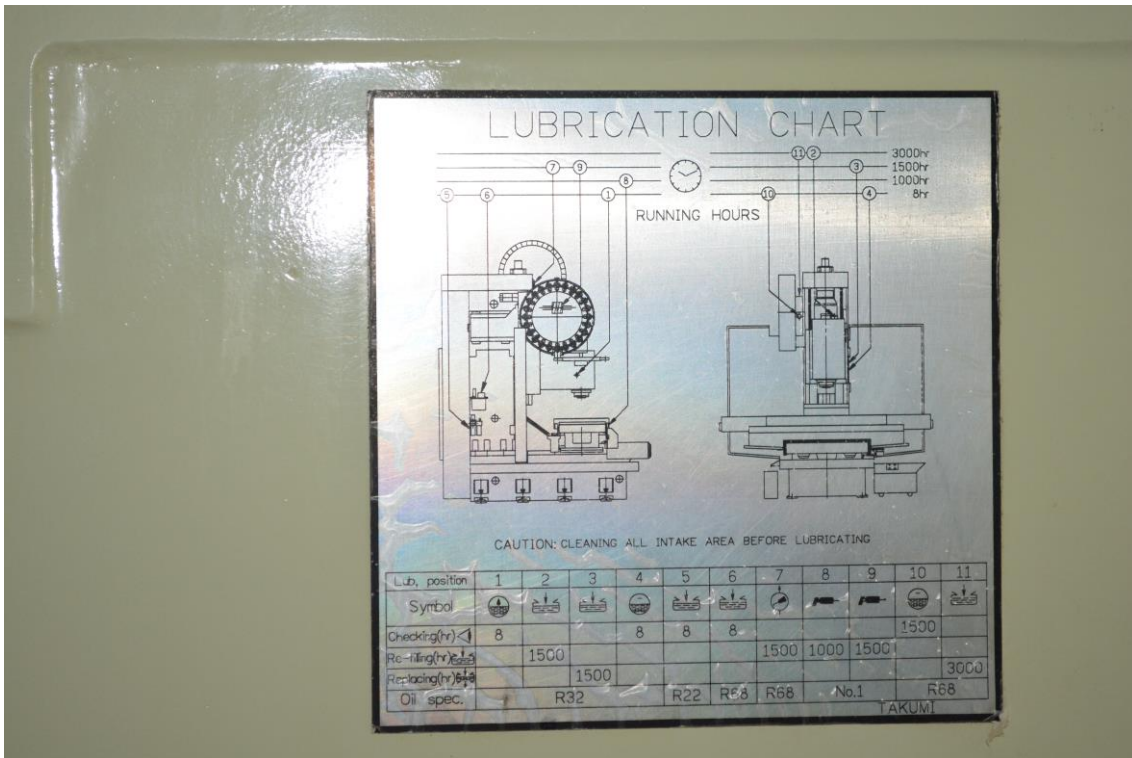



Accuracy test chart

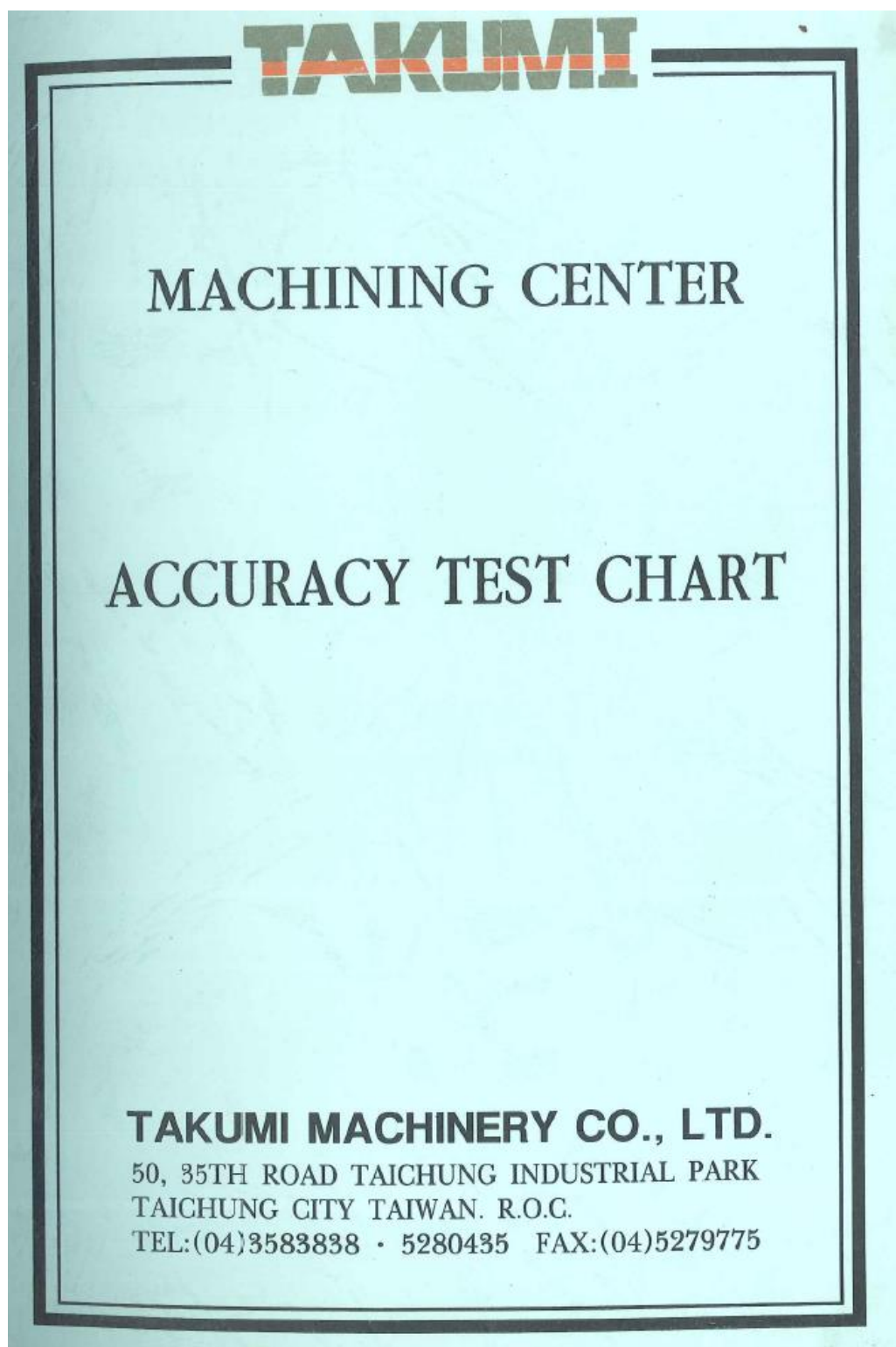

TAKUMI

-A NAME YOU WILL STICK TO-
HONEST. EXPERIENCED. QUALIFIED

CERTIFICATE OF WARRANTY

DATE: 1999 07 NO: _____

CUSTOMER : _____
WARRANTY PERIOD : _____
MACHINE'S MODEL : VIIA
MACHINE'S SERIAL NO: 60490
CONTROL SYSTEM : MITSUBISHI M520BMR
CONTROL'S Y NO : M52Y7302816Y

CONDITIONS OF WARRANTY:

TAKUMI MACHINERY CO., LTD. WARRANTS THIS MACHINE TO BE FREE OF DEFECT IN WORKMANSHIP OF MATERIAL. IN CASE ANY SUCH DEFECT IS FOUND, OR IF THIS MACHINE FAILS TO OPERATE PROPERLY UNDER SERVICE MANUAL INSTRUCTION AND NORMAL CONDITIONS OF USE WITHIN WARRANTY PERIOD. PLEASE CONTACT OUR LOCAL DEALER OR SEND A FAX TO US IMMEDIATELY. WE WILL DEEM IT AS FIRST PRIORITY TO REPAIR YOUR MACHINE. ALL SERVICE PROVIDED AND SPARE PARTS USED FOR MAINTENANCE WITHIN WARRANTY PERIOD ARE BASED ON FREE - OF - CHARGE EXCLUDES THE CONTROL SYSTEM WITHOUT EXTENDED WARRANTY.

THIS WARRANTY DOES NOT COVER DAMAGES RESULTING FROM ACCIDENT WHICH INCLUDES FORCE MAJEURE AND MISUSED.

AFTER THE EXPIRATION OF THE WARRANTY PERIOD, ANY REPAIR OF THIS MACHINE CAN BE MADE BY OUR WORLDWIDE AGENT NETWORK OR IN OUR FACTORY AT A REASONABLE CHARGE.

TAKUMI MACHINERY CO., LTD.

AUTHORIZED SIGNATURE _____

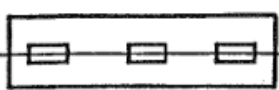
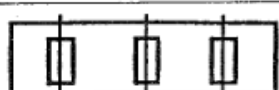
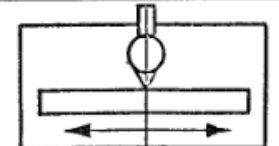
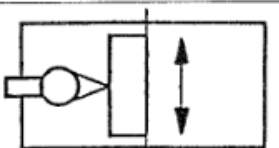
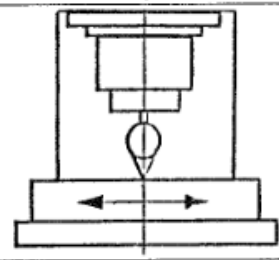
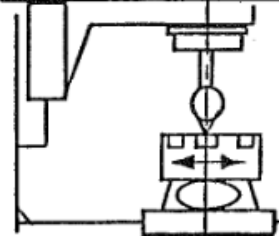
| No. | INSPECTION ITEMS | FIGURE | Tolerance | | | MEASURE- MENTS |
|-----|--|--|-----------------|-------------------|--------------------|-------------------|
| | | | Movement Amount | | | |
| | | | Under 500 | 500 TO 1000 | 1000 TO 2000 | UNIT : MM |
| 1 | STRAIGHTNESS OF UPPER SURFACE OF TABLE | X-AXIS DIRECTION  | 0.05/M | 0.06/M | | 0.04 |
| | | Y-AXIS DIRECTION  | 0.04/M | | | 0.03 |
| 2 | STRAIGHTNESS OF TABLE MOVEMENT IN X-Y PLANE | X-AXIS DIRECTION  | 0.01/500 | | | 0.004 |
| | | Y-AXIS DIRECTION  | | | | 0.004 |
| 3 | PARALLELISM OF X-AXIS MOVEMENT OF TABLE TO ITS UPPER SURFACE |  | 0.02 | 0.03 | 0.04 | 0.014 |
| 4 | PARALLELISM OF Y-AXIS MOVEMENT OF TABLE TO ITS UPPER SURFACE |  | 0.02 | 0.03 | — | 0.013 |

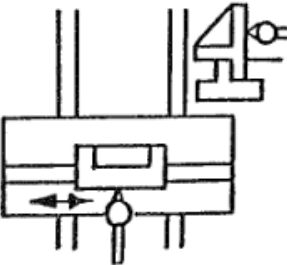
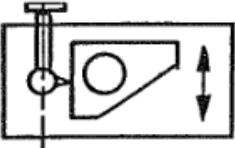
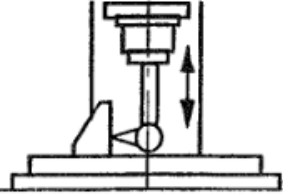
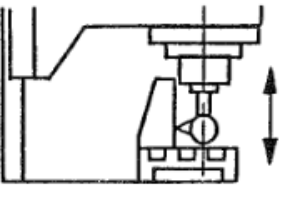
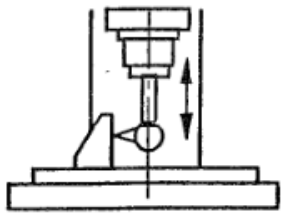
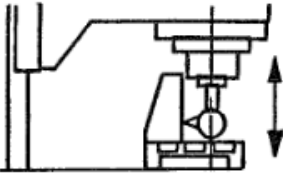
| No. | INSPECTION ITEMS | FIGURE | Tolerance | | | MEASURE- MENTS |
|-----|--|--|-----------------|-------------|--------------|-------------------|
| | | | Under 500 | 500 TO 1000 | 1000 TO 2000 | |
| 5 | PARALLELISM OF X-AXIS MOVEMENT OF TABLE TO SIDE OF MIDDLE T SLOT OF TABLE |  | Movement Amount | | | 0,022 |
| | | | 0.02 | 0.03 | 0.04 | |
| 6 | SQUARENESS OF X-AXIS MOVEMENT TO Y-AXIS MOVEMENT |  | 0.015 / 300 | | | 0,008 |
| 7 | STRAIGHTNESS OF Z-AXIS MOVEMENT | X-Z PLANE  | 0.01 / 300 | | | 0,006 |
| | | Y-Z PLANE  | 0.01 / 300 | | | 0,006 |
| 8 | SQUARENESS OF Z-AXIS MOVEMENT TO TABLE SURFACE | X-Z PLANE  | 0.02 / 300 | | | 0,01 |
| | | Y-Z PLANE  | 0.02 / 300 | | | 0,007 |

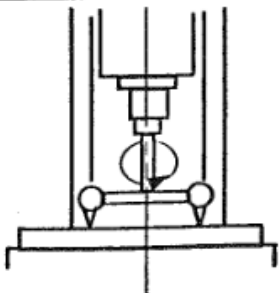
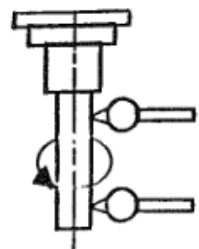
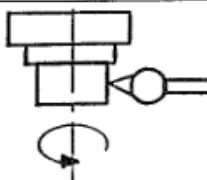
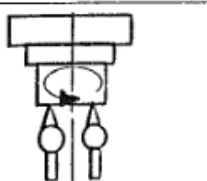
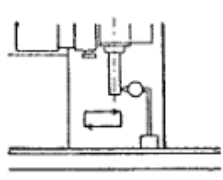
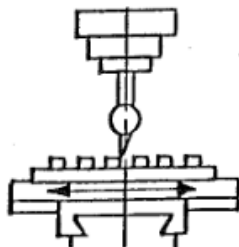
| No. | INSPECTION ITEMS | | FIGURE | Tolerance | | | MEASUREMENTS |
|-----|---|------------------|---|-----------------------------------|-------------|--------------|--------------|
| | | | | Movement Amount | | | |
| 9 | SQUARENESS OF UPPER SURFACE OF TABLE TO CENTRE LINE OF MAIN SPINDLE | X-AXIS DIRECTION |  | Under 500 | 500 TO 1000 | 1000 TO 2000 | 0.013 |
| | | Y-AXIS DIRECTION | | 0.02 / 300 | | | 0.008 |
| 10 | MAIN SPINDLE TAPER HOLE RUN-OUT | |  | AT FIX END 0.008 | | | 0.004 |
| | | | | AT POINT 300 0.02 | | | 0.014 |
| 11 | RUN-OUT OF SPINDLE | |  | 0.01 | | | 0.004 |
| | | |  | 0.01 | | | 0.004 |
| 12 | REPEATABILITY OF LINEAR MOVEMENT | |  | ± 0.01 | | | X : ± 0.002 |
| | | | | | | | Y : ± 0.002 |
| | | | | | | | Z : ± 0.002 |
| 13 | POSITIONING ACCURACY | |  | 0.02 / 300 FULL TRAVEL 0.04 | | | X : 0.003 |
| | | | | | | | Y : 0.002 |
| | | | | | | | Z : 0.002 |

ACCURACY TEST CHART

CUSTOMER _____

| | |
|------------------------------|---------------------------|
| TYPE | <u>V11A</u> |
| SERIAL NO. | <u>60490</u> |
| CONTROL SYSTEM TYPE | <u>MITSUBISHI M500AMP</u> |
| SERIAL NO. OF CONTROL SYSTEM | <u>M50Y7302816Y</u> |
| INSPECTION DATE | <u>1997.07</u> |
| INSPECTED BY | <u>Shy. Line. wang</u> |
| APPROVED BY | <u>Jin Wei Chung</u> |

1. This test has been established based on JIS standard.
2. The following are quoted from JIS : Test Code for Accuracy of Numerically Controlled Knee Type Vertical Milling Machine (B-6338)
3. Regulations on test
 - a). Test shall be conducted, in principle, in factory where the numerically controlled machine tools are manufactured.
 - b). Test shall be conducted, in principle, under the condition that the numerically controlled machine tool with every part functioning and temperature, lubrication and other conditions have been almost stabilized.
 - c). Static accuracy shall be measured, in principle, under the condition that the numerically controlled machine tool is not loaded with workpiece.
 - d). For other details of test, JIS standard shall be applied.

TAKUMI

TAKUMI MACHINERY CO.,LTD
 DEPARTMENT : QUALITY ASSURANCE

CIRCULARITY SPECIFICATION: 0.025/300mm

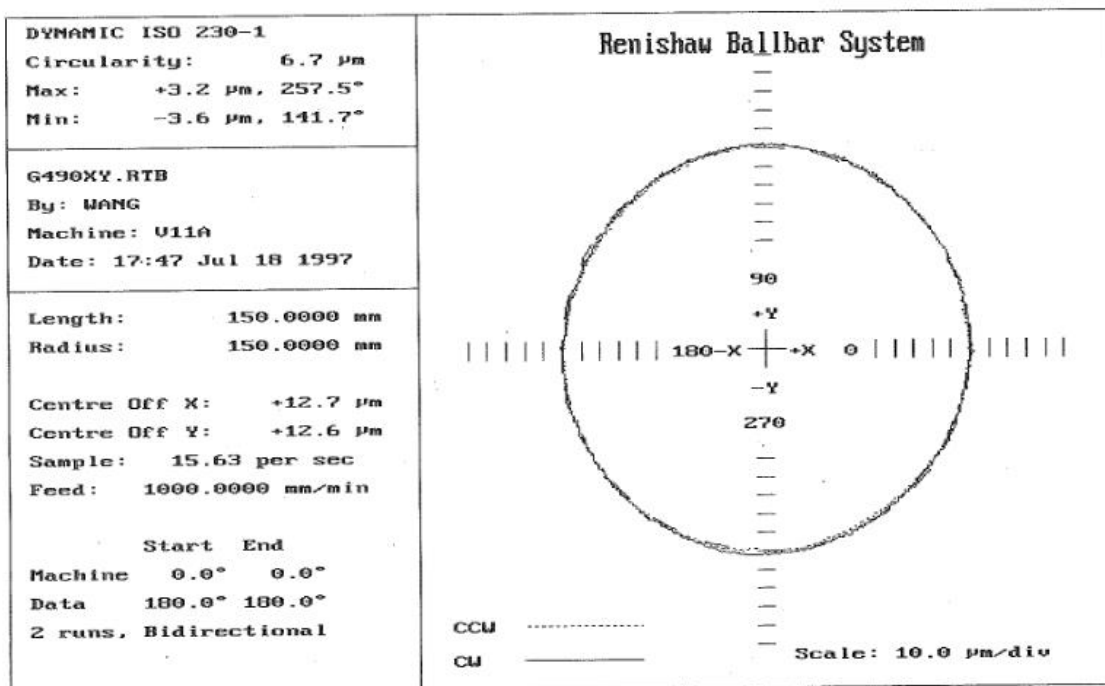

Przedstawiona oferta cenowa ma charakter informacyjny, nie stanowi oferty handlowej w rozumieniu Art.66 par.1 Kodeksu Cywilnego