

INSTALLATION AND OPERATING INSTRUCTIONS

VARI-PAK

CYCLING DC MOTOR CONTROL

– Designed for Indexing Applications –

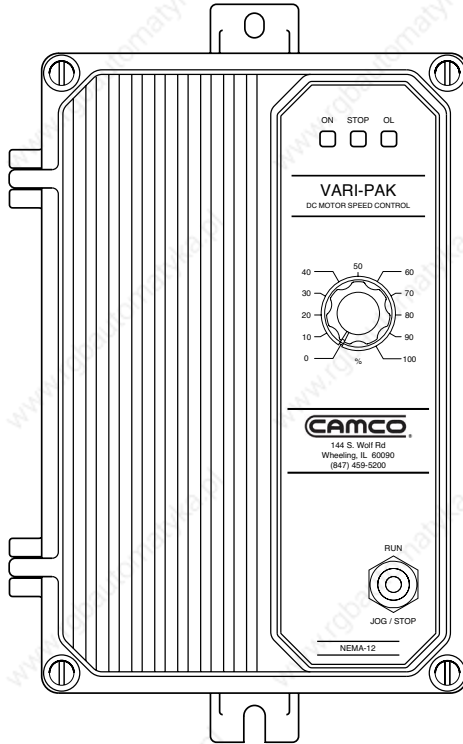

This manual covers the following CAMCO part numbers:
92A61633010000, 92A61633020000, 92A61633030000, 92A61633040000

See Safety Warning on Page 2

The information contained in this manual is intended to be accurate. However, the manufacturer retains the right to make changes in design which may not be included herein.

CAMCO

FERGUSON

Industrial Motion Control, LLC

© 2003 KB Electronics, Inc.

TABLE OF CONTENTS

Section	Page
i. Simplified Operating Instructions	1
ii. Safety Warning	2
I. Introduction	2
II. Mounting	8
III. Setting Motor Current (Jumper J1)	8
IV. Wiring	8
V. Fusing	10
VI. Logic Function and Wiring	10
VII. Application Wiring Diagrams	12
VIII. Application Wiring Diagrams (Reversible Models)	15
IX. Operation	15
X. Trimpot Adjustments	16
XI. Function Indicator Lamps	17
XII. Troubleshooting Guide	19
Tables	
1. Electrical Ratings	3
2. General Performance Specifications	4
3. Selectable Jumper Reference Chart	8
4. Jumper J1 Setting vs Motor Horsepower	8
5. Terminal Block Wiring Information	9
6. Jumper "JW" Operation	12
Figures	
1. Typical Indexing Performance	4
2A. Control Layout (Non-Reversing Units)	5
2B. Control Layout (Reversing Units)	6
3. Mechanical Specifications	7
4. AC Line & Armature Connection	9
5. Remote Potentiometer Connection	10
6. Analog Voltage Connection	10
7. Run Command	10
8. Jog Command	11
9. Jog Command used as Stop	11
10. Stop Command	11
11. Jumper "JR" Operation	12
12. Solid State Switching	13
13. Contact Switching	13
14. Correct Keyway Position for CAM & Limit Switch Assemblies	13, 14
15. Cycle on Demand Wiring	14
16. Sequence of Cycle on Demand Operation	15
17. Reversing Logic Wiring Diagram	16
18. Internal Wiring Diagram	20

i. SIMPLIFIED OPERATING INSTRUCTIONS

IMPORTANT – You must read these simplified operating instructions before proceeding. These instructions are to be used as a reference only and are not intended to replace the detailed instructions provided herein. You must read the Safety Warning, on page 2, before proceeding.

- A. AC Power** – Use 120 Volt AC rated controls on 120 Volts AC and 240 Volt AC rated controls on 240 Volts AC. Connect AC power to terminal block TB2 terminals L1 and L2. When power is applied, the power on (ON) LED on the front cover will illuminate.

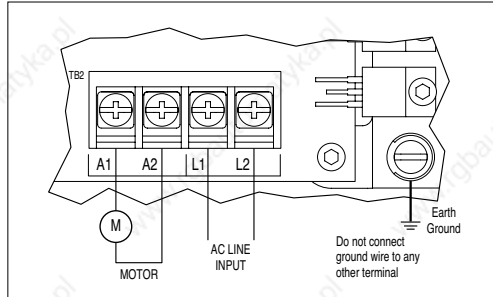

Be sure input AC line voltage corresponds to control voltage rating. Be sure AC power is disconnected when making other connections to control. Do not bundle AC power and motor wires with wires connected to TB1 terminals.

- B. Motor Leads** – Connect the motor leads to terminal block TB2 terminals A1 and A2. Be sure motor nameplate voltage rating corresponds to control output voltage rating. Do not use control with shunt wound motors.

JUMPER J1 SETTING vs MOTOR HORSEPOWER

Jumper J1	Motor Horsepower Range	
	90 VDC	180 VDC
2A	1/6	1/3
3.3A	1/4 – 1/3	1/2 – 3/4
5A	1/2	1
10A	3/4 – 1	1½ – 2

Note: Jumper "J1" is shown in the factory setting for 120 Volts AC controls (3.3 Amps).

- C. Motor Current Setting** – Be sure Jumper J1 is set to the approximate rated motor current (10A, 5A, 3.3A, 2A).
- D. Trimpot Settings** – Trimpots should be set to the approximate position as shown:

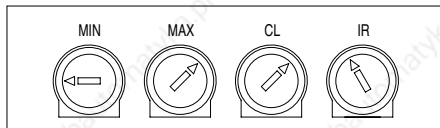

- E. Main Speed Pot** – Turn the main speed pot on the front cover of the control to a 15% or greater setting.

Special Instruction for Cycle on Demand Applications

The camshaft of the Index Drive should be in the middle of its dwell position. This is the position in which the motor should receive its signal to start. Connect the normally closed side of the cycling limit switch (LS1) to the control's TB1 terminals STOP (4) and RTN (3). **Note:** See figure 14A-C, on pages 13 and 14, for information regarding the correct dwell position for your Index Drive model and cycling cam lobe positions.

ii.  **SAFETY WARNING! Please read carefully**

This product should be installed and serviced by a qualified technician, electrician, or electrical maintenance person familiar with its operation and the hazards involved. Proper installation, which includes wiring, mounting in proper enclosure, fusing or other over current protection, and grounding can reduce the chance of electrical shocks, fires, or explosion in this product or products used with this product, such as electric motors, switches, coils, solenoids, and/or relays. Eye protection must be worn and insulated adjustment tools must be used when working with control under power. This product is constructed of materials (plastics, metals, carbon, silicon, etc.) which may be a potential hazard. Proper shielding, grounding and filtering of this product can reduce the emission of radio frequency interference (RFI) which may adversely affect sensitive electronic equipment. If further information is required on this product, contact the Sales Department. It is the responsibility of the equipment manufacturer and individual installer to supply this Safety Warning to the ultimate end user of this product. (SW effective 9/2000).

This control contains Start/Stop and Inhibit circuits that can be used to start and stop the control. However, these circuits are never to be used as safety disconnects since they are not fail-safe. Use only the AC line for this purpose.

The potentiometer circuit (P1, P2, P3) of this control is not isolated from AC line. Be sure to follow all instructions carefully. Fire and/or electrocution can result due to improper use of this product.



This product complies with all CE directives pertinent at the time of manufacture. Contact factory for detailed installation and Declaration of Conformity. Installation of a CE approved RFI filter (KBRF-200A [P/N 9945C] or equivalent) is required. Additional shielded motor cable and/or AC line cables may be required along with a signal isolator (Camco P/N 99A61455000000).



WARNING
SHOCK HAZARD!
Before operating or servicing this control, you must carefully read the Instruction Manual.

A label like the one shown, appears on the top side of your VARI-PAK unit. If this label is not on your control, notify CAMCO immediately! 1-800-645-5207.

I. INTRODUCTION

The VARI-PAK Series is housed in a rugged die cast aluminum NEMA 12 enclosure. The controls are designed specifically for cycling and indexing applications. A variety of models provide different features and input voltage ratings (see table 1, on page 3). The controls provide the user with isolated logic functions: STOP, JOG and RUN. Other functions, such as cycle on demand, can easily be obtained. An important feature of the control is jumper J1 which is used for DC current selection. It automatically presets the IR Compensation and Current Limit for safe operation on various motors. Standard features include an LED indicator array for "power on," "stop" and "overload." Part Numbers 92A61633020000 and 92A61633040000 also contain logic input for "Reverse Run" and "Reverse Jog." The controls contain trimpots that can be used to readjust Minimum and Maximum speed, Current Limit and IR Compensation. The front panel contains a built-in 5K ohm speed potentiometer and a Run, Jog/Stop switch. (See table 3, on page 8, for selectable jumper information.)

IMPORTANT! Control part number and ratings must correspond to the AC line voltage, motor voltage and type of operation (Unidirectional or Reversing). See table 1.

TABLE 1 – ELECTRICAL RATINGS

Part Number	Input Line Voltage (VAC 50/60 Hz \pm 10%)	Motor Armature Voltage (VDC)	Maximum AC Load Current (RMS Amps)	Maximum DC Load Current (DC Amps)	Maximum Horsepower HP, (kW)	Type of Operation	Logic Provided
92A61633010000	120	0 – 90	15.0	10.2	1, (0.75)	Unidirectional	Run, Jog, Stop, Rtn
92A61633020000	120	0 – 90	15.0	10.2	1, (0.75)	Reversing	Fwd Run, Fwd Jog, Stop, Rev Run, Rev Jog, Rtn
92A61633030000	240	0 – 180	15.0	10.2	2, (1.5)	Unidirectional	Run, Jog, Stop, Rtn
92A61633040000	240	0 – 180	15.0	10.2	2, (1.5)	Reversing	Fwd Run, Fwd Jog, Stop, Rev Run, Rev Jog, Rtn

TABLE 2 – GENERAL PERFORMANCE SPECIFICATIONS

Parameter (Units)	Specifications		Specifications	
	Part Nos.	Factory Setting	Part Nos.	Factory Setting
	92A61633010000 92A61633020000		92A61633030000 92A61633040000	
AC Line Input (VAC ± 10%, 50/60 Hz)	115	—	208/230	—
Horsepower Range HP, (kW)	1/6 – 1, (0.12 – 0.75)	1/3, (0.25)	1/3 – 2, (0.25 – 1.5)	1/4, (0.18)
Armature Voltage Range (VDC)	0 – 100	85	0 – 200	170
Current Ranges (ADC)	2, 3.3, 5, 10	3.3	2, 3.3, 5, 10	2
CL Trimpot Range (% Range Setting)	0 – 170	150	0 – 170	150
MIN Speed Trimpot Range (% Base Speed)	0 – 30	0	0 – 30	0
MAX Speed Trimpot Range (% Base Speed)	60 – 120	100	60 – 120	100
IR COMP Trimpot Range (% Base Speed)	0 – 15	4	0 – 30	8
Speed Range (Ratio)	50:1	—	50:1	—
AC Line Voltage Regulation (% Base Speed)	± 0.5	—	± 0.5	—
Voltage Following Linearity (% Base Speed)	± 0.5	—	± 0.5	—
Load Regulation (% Base Speed)	± 1	—	± 1	—
Ambient Temperature Range (°C)	0 – 45	—	0 – 45	—
Potentiometer, Front Cover (ohms – watts)	5K – 1/3	—	5K – 1/3	—
Maximum Run/Stop Operations (ops/min)	30	—	30	—
Enclosure Type (NEMA)	12	—	12	—

FIGURE 1 – TYPICAL INDEXING PERFORMANCE

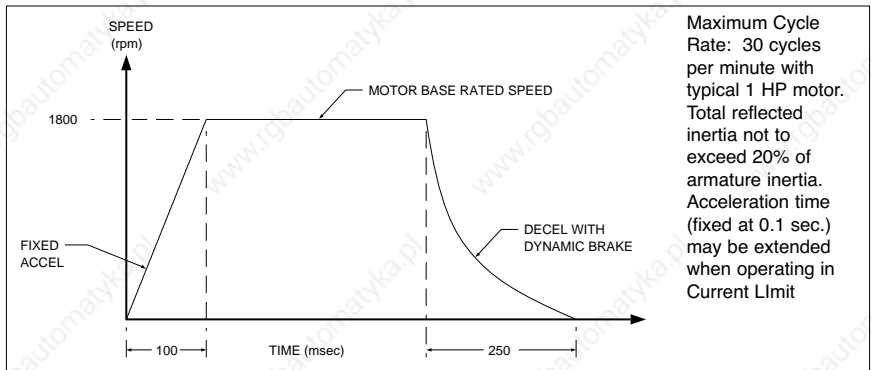

**FIGURE 2A – CONTROL LAYOUT (Non-Reversing Units)
(92A61633010000 and 92A61633030000)**

(Illustrates Factory Setting of Jumpers and Approximate Trimpot Settings)

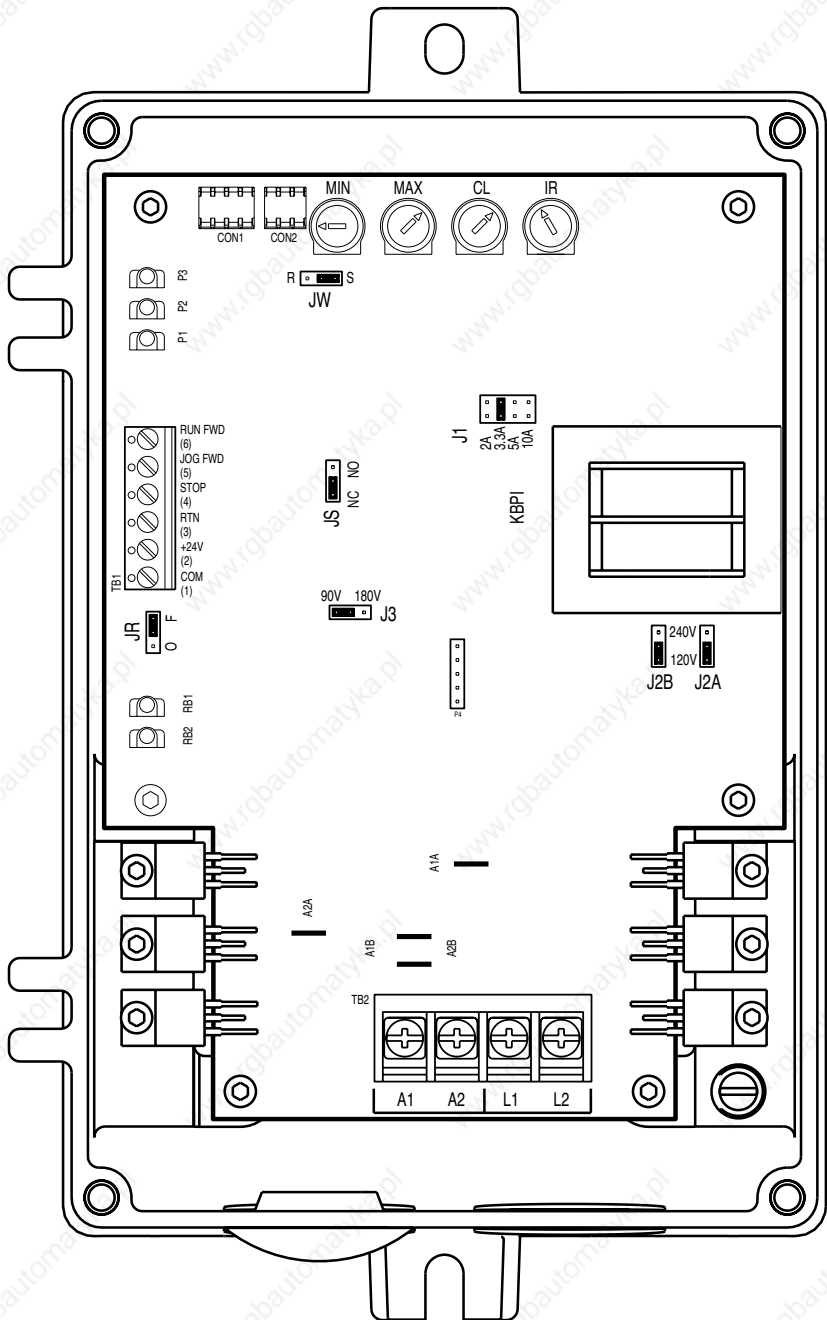

FIGURE 2B – CONTROL LAYOUT (Reversing Units)

(92A61633020000 and 92A61633040000)

(Illustrates Factory Setting of Jumpers and Approximate Trimpot Settings)

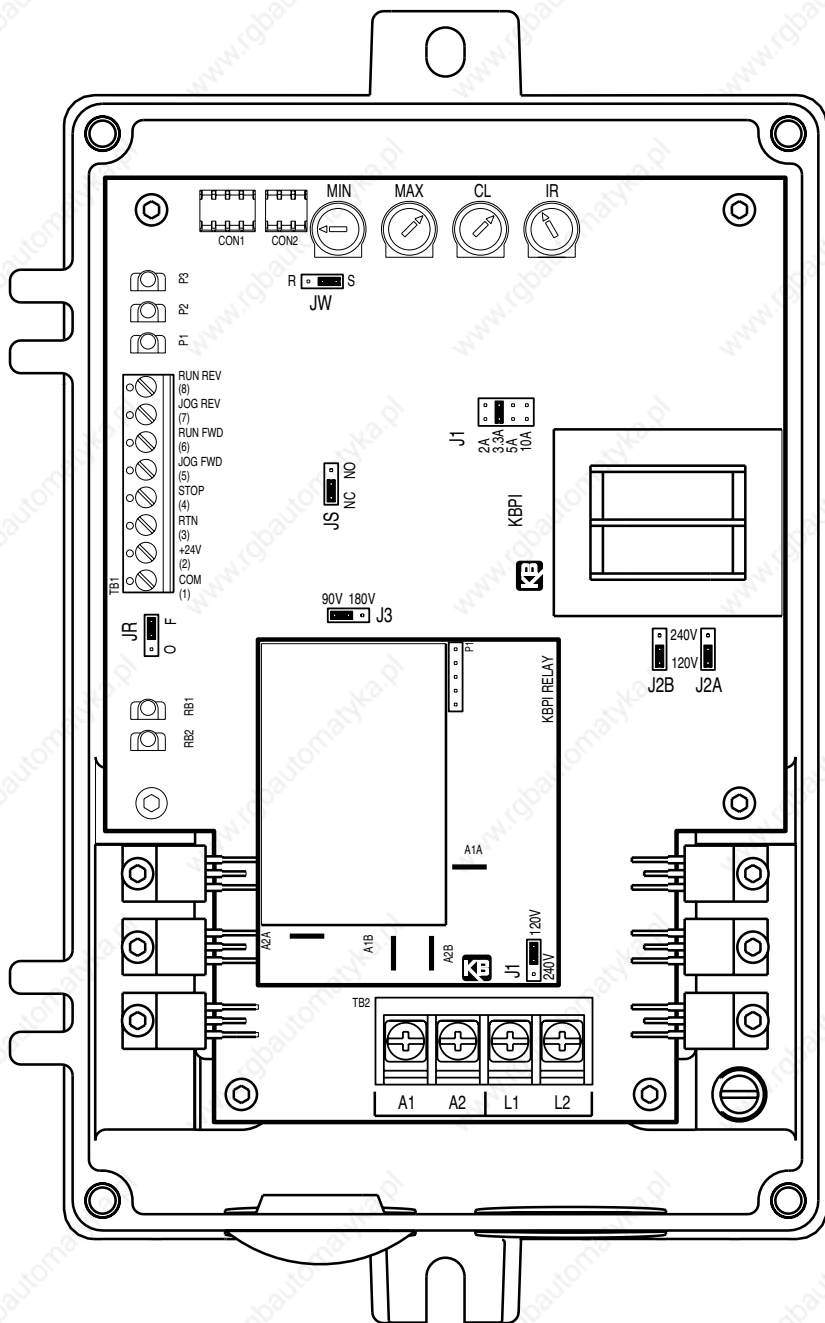

FIGURE 3 – MECHANICAL SPECIFICATIONS (Inches / [mm])

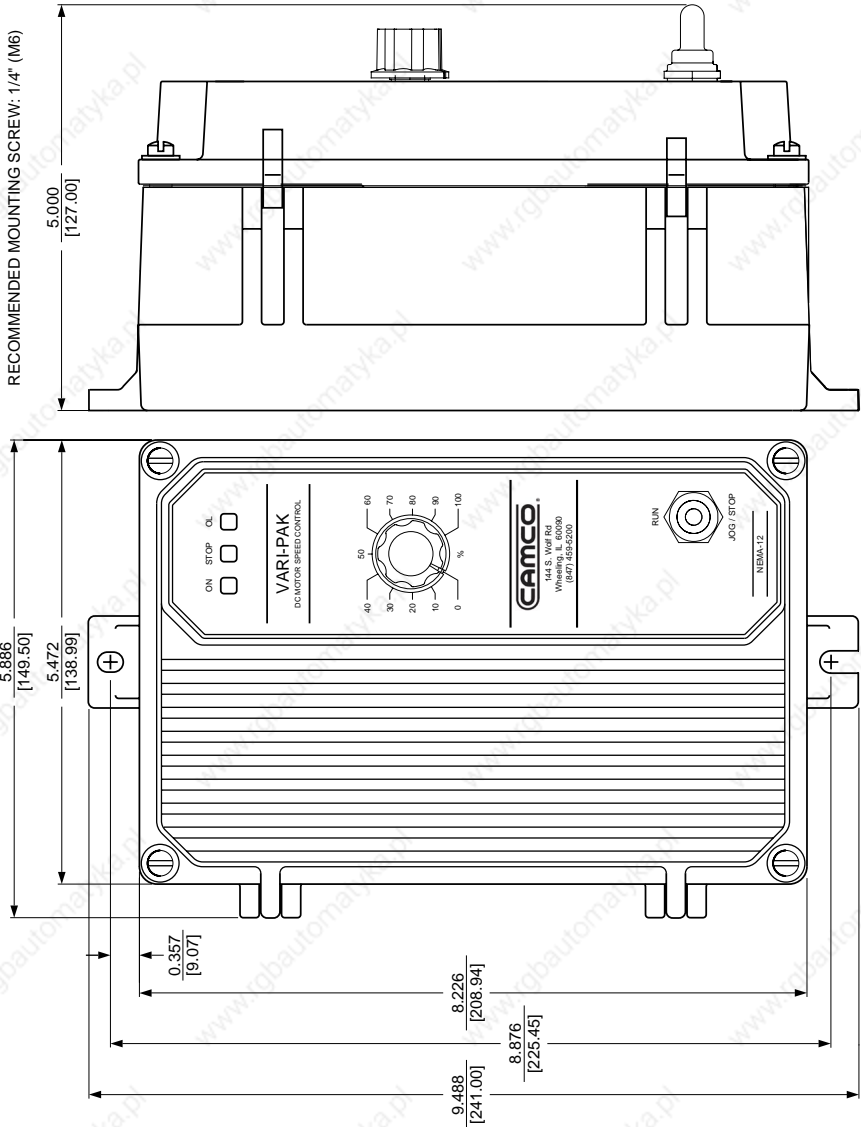

TABLE 3 – SELECTABLE JUMPER REFERENCE CHART

Jumper	Location*	Description	Factory Setting
J1	1	Establishes the range of maximum armature current	See section III, page 8
J2A, J2B	1	Sets the AC input line voltage (120 or 240 Volts AC) for the main PC Board	Set according to model part numbers. See table 1, Page 3
J3	1	Sets the DC output voltage range to motor (90V/180V)	Set according to model part numbers. See table 1, Page 3
JR	1	Used to activate the return (RTN) circuit. "F" position – RTN is jumpered to common. "O" position – RTN used as a logic disable. See section VI D, on page 11	Set to "F" position
JS	1	Used to set the STOP function operation. "NC" position – Use a normally closed contact for open to stop operation. "NO" position – Use a normally open contact for "close to stop" operation.	Set to "NC" position
J1	2	Sets the operating AC line voltage for the Relay Board (120 or 240 VAC)	Set according to model part numbers. See table 1, Page 3
JW	1	Determines the priority of the Run and Stop logic commands. See table 6, on page 12.	Set to "R" position for "cycle on demand"

*NOTE: Location 1 Main Speed Control Board – Location 2 Relay Board (found on reversing models only).

II. MOUNTING





Mount the control in a vertical position on a flat surface. Be sure to leave enough room below the bottom of the control to allow for the AC line and motor connections and other wiring that may be necessary. Care should be taken to avoid extreme hazardous locations where physical damage can occur. **Note: Do not use this control in an explosion proof application.** If the control is mounted in a closed, unventilated cabinet, remember to allow for proper heat dissipation. If full rating is required, a minimum enclosure size of 12" W x 24" H x 12" D should be used.

Front Cover – The VARI-PAK case is designed with a hinge so that when the front cover is open, all wiring stays intact. To open the cover, the four cover screws must be loosened, so they no longer are engaged in the case bottom. After mounting and wiring, close the front cover, **making sure all wires are contained within the enclosure and the gasket is in place around the cover lip.** Tighten all four cover screws so that the gasket is slightly compressed. Do not overtighten.

III. SETTING MOTOR CURRENT (Jumper J1)

Jumper J1 (on the Main Board) is used to set the range of armature current which can be further modified with the current limit (CL) trimpot. The factory setting of J1 is 3.3 amps for 120 VAC controls and 2 amps for 240 VAC controls. The CL trimpot is factory set to provide 150% of the J1 setting. For example, when J1 is in the 10 amp position, the actual armature current is 15 amps. When J1 is in the 5 amp position, the control provides a maximum armature current of 7.5 amps. The position of J1 should be set to the approximate DC motor current rating. Table 4 is provided as a reference.

TABLE 4 – JUMPER J1 SETTING vs MOTOR HORSEPOWER

Jumper J1	Motor Horsepower Range	
	90 VDC	180 VDC
2A 	1/6	1/3
3.3A 	1/4 – 1/3	1/2 – 3/4
5A 	1/2	1
10A 	3/4 – 1	1½ – 2

IV. WIRING



WARNING! Read Safety Warning on page 2 before attempting to use this control. Wire control in accordance with the National Electrical Code requirements and other codes that apply. Be sure to fuse each conductor which is not at ground potential.

Failure to follow the Safety Warning Instructions may result in electric shock, fire or explosion. **Do not fuse neutral or grounded conductors.** Note: See section V, Fusing, on page 10. A separate AC line switch, or contactor, must be wired as a disconnect switch, so that the contacts open each ungrounded conductor. (See figure 4, below for AC Line and Armature Connection.) **Note: Do not bundle AC or motor leads with logic leads or erratic operation may occur.**

TABLE 5 – TERMINAL BLOCK WIRING INFORMATION

Terminal Block Designation	Connection Designation	Supply Wire Gauge*		Maximum Tightening Torque (in-lbs)
		Minimum	Maximum	
TB2	A1, A2, L1, L2	22	12	12
TB1	Logic Connections	24	14	3.5

*Use Cu wire only (AWG)

1. Twist logic wires (speed adjustment potentiometer or voltage signal input wires) to avoid picking up electrical noise. If wires are longer than 18", use shielded cable.
2. You may have to earth ground the shielded cable. If noise is coming from devices other than the drive, ground the shield at the drive end (ground screw in enclosure). If noise is generated by a device on the drive, ground the shield at the end away from the drive. Do not ground both ends of the shield.
3. Do not bundle logic wires with power carrying lines or sources of electrical noise. Never run speed adjustment potentiometer or voltage signal input wires in the same conduit as motor or AC line voltage wires.
4. Connect earth ground to the earth ground screw provided in the enclosure. (See figure 4 for ground screw location.)

Two .875" (22.2 mm) knock out holes are provided for a standard 1/2" knockout connector (not supplied) for wiring. A plug is provided if only one knockout is required. Be sure to use suitable connectors and wiring that is appropriate for the application.

A. AC Line – Connect AC Line to terminals L1 and L2. (Be sure the control model and rating match the AC line input voltage. See table 1, on page 3.)

B. Motor Armature – Connect motor armature to terminals A1 (+) and A2 (-). (See table 1, on page 3).

WARNING! Do not wire switches or relays in series with the armature. **Armature switching can cause catastrophic failure of motor and/or control. Do not bundle AC line and motor wires with other wires (e.g. potentiometer, analog input, Run, Jog, Stop, etc.) since erratic operation may occur. Do not use this control on shunt wound motors.**

C. Ground – Be sure to ground (earth) the control by connecting a ground wire to the Green Ground Screw located to the right of the terminal block. **Do not connect ground wire to any other terminals on control.**

D. Main Potentiometer – The control is supplied with the main potentiometer prewired. However, the control can also be operated from a remote potentiometer, or from an **isolated** analog voltage for voltage following. To operate from an external source remove white, orange and violet potentiometer leads from terminals P1, P2 and P3. The leads may be taped and left in the control. The potentiometer itself may be removed, if a seal is used to cover the hole in the front cover. **Note: Use shielded cable on all connections to P1, P2, or P3 over 12" (30cm) in length. See section IV, items 1-4.**

FIGURE 4 – AC LINE & ARMATURE CONNECTION

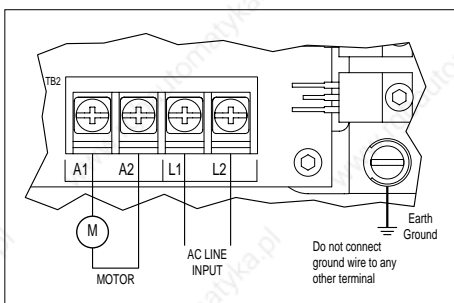

1. Remote Potentiometer. Connect remote potentiometer wires to terminals P1, P2 and P3, so that the "high" side of the potentiometer connects to P3, the "wiper" to P2 and the "low" side to P1. (See figure 5.)
2. Analog Input. An **isolated** 0-10VDC analog voltage can also be used to drive the control. **Note: If an isolated signal voltage is not available, an optional signal isolator (Camco P/N 99A6145500000) should be used.** Connect the **isolated** input voltage to terminal P2 (positive) and P1 (negative). (See figure 6.) Adjust the MIN trimpot clockwise to achieve a 0+ output voltage.

FIGURE 5 – REMOTE POTENTIOMETER CONNECTION

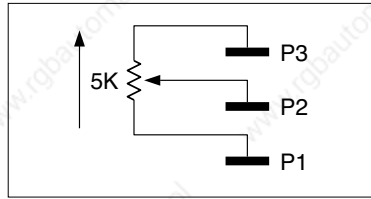
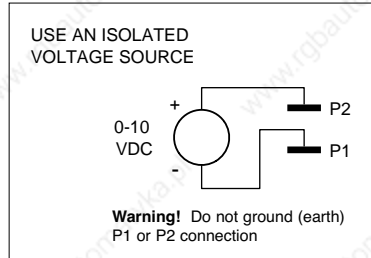

FIGURE 6 – ANALOG VOLTAGE CONNECTION



V. FUSING

AC Line Fusing – Most electrical codes require that each ungrounded conductor contain fusing. Separate branch circuit fusing or circuit breaker may be required. Check **all** electrical codes that may apply to the installation. This control does **not** contain AC line fuses. A 20 amp rated fuse or circuit breaker can be used.

VI. LOGIC FUNCTIONS AND WIRING



Warning! Do not use any of the logic functions (STOP, RTN) as an emergency stop since they are not fail-safe. Use only an AC line (L1, L2) disconnect for that purpose. To prevent erratic operation, do not bundle logic wiring with AC line and motor wires. Use shielded cables on logic wiring over 12" (30 cm) in length. See section IV, items 1-4, on page 9.

The control contains several logic functions which are described in detail below. All connections are made to terminal block TB1. (See figures 2A and 2B, on pages 5 and 6, for TB1 location.)

A. "RUN" – Note:

This terminal is sometimes marked "START" in older models.

A **momentary** contact closure between terminals "RUN" and "RTN" latches the control into a continuous run mode. To stop the control, the stop circuit must be activated by opening the contact between the

"STOP" and "RTN" terminals. **Note: All momentary closures must be present for no less than 50 milliseconds and a normally closed (NC) contact must be maintained between the "Stop" and "RTN" terminals in order for the drive to run.**

FIGURE 7 – RUN COMMAND

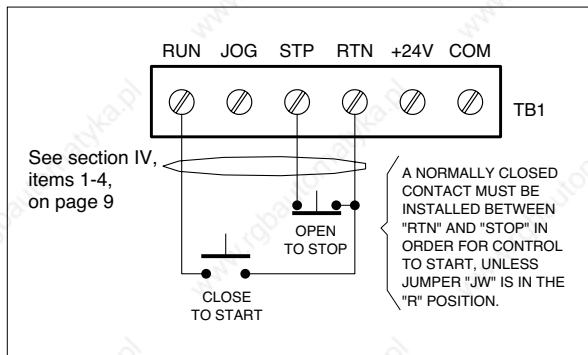

- B. **"JOG" (Stop)** – A maintained contact closure between terminals "JOG" and "RTN" will cause the control to run continuously. This is not a latching function. The drive will run only as long as the contact is closed and stop when it is opened. (See figure 8.)

Application Note:

The "JOG" can also be used as a normally open (NO) "STOP" command. When the control is started with the momentary "RUN" command, it can be stopped by connecting a momentary contact between the "JOG" and the "RTN" terminals. See figure 9. (Note: The control can also be stopped by opening the "STOP" contact.)

- C. **"STOP"** – Use a normally closed (NC) contact between terminals "STOP" and "RTN." Opening the contact activates the control's Dynamic Brake producing a rapid stop. (Note: A normally open (NO) limit switch or contact can also be used to activate the stop command. To use a (NO) contact, move jumper JS to the "NO" position.) (See table 3, page 8.)

Application Note:

The setting of jumper "JW" establishes the priority a "STOP" command has over a "RUN" command. If jumper "JW" is placed in position "S," the "STOP" command has priority over the "RUN". If the "STOP" is activated (contact open), the control cannot be started with the "START" command. If jumper "JW" is in the "R" position (factory setting), the "RUN" command has priority over the "STOP." In this mode of operation the control can be started with the "RUN" command even though the "STOP" is activated. This setting of jumper JW in the "R" position is used for cycle on demand applications. See table 6, on page 12, for detailed information of jumper "JW" operation. Warning! Do not use as safety stop. See Safety Warning on page 2.

- D. **"RETURN" (RTN)** – When Jumper "JR" is moved to position "O" from the factory setting "F," it disables all of the command functions (Run, Jog, Stop, etc.) and causes the control to stop. To enable these functions, a contact must be placed between the "RTN" and "COM" terminals.

FIGURE 8 – JOG COMMAND

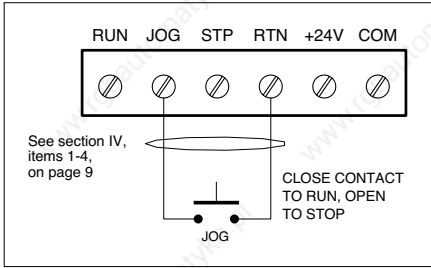

FIGURE 9 – JOG COMMAND USED AS STOP

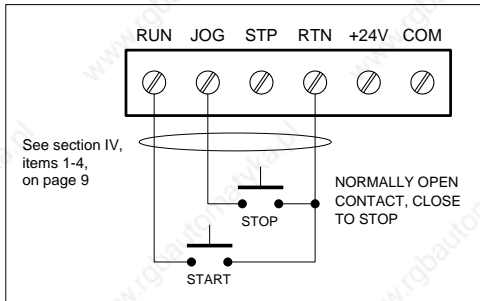
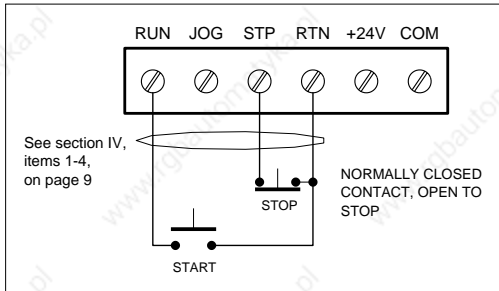

FIGURE 10 – STOP COMMAND



Warning! Do not use as emergency or safety stop. See Safety Warning on page 2. See figure 11, on page 12, for jumper "JR" operation. Failure to follow the Safety Warning Instructions may result in electric shock, fire or explosion.

TABLE 6 – JUMPER “JW” OPERATION



Jumper “JW” Setting	Description	Circuit	Operation
 <p>S ■ ■ R</p> <p style="text-align: center;">JW</p> <p>Factory setting</p>	<p>“Run” has priority over “Stop.” Control will run even if stop contact is open. Use this setting for “Cycle on Demand” operation.</p>		<p>When start contact is made, control will run with stop open. If stop is closed and then reopened, control will stop.</p>
 <p>S ■ ■ R</p> <p style="text-align: center;">JW</p>	<p>“Stop” has priority over “Run.” Control will run only when stop contact is closed.</p>		<p>When start contact is made, stop contact must be closed for control to run.</p>

FIGURE 11 – JUMPER “JR” OPERATION

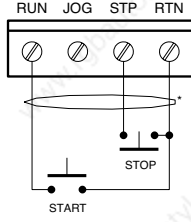

*See section IV, items 1-4, on page 9.

- E. +24 VDC SUPPLY** – The +24V terminal provides a nominal¹ 24 VDC @ 12 mA output for use with an external load such as one solid-state 3-wire proximity switch.
- F. Common “COM”** – This terminal is referenced to all logic signals (RUN, JOG, STOP) through the Return (“RTN”) terminal. The control is factory supplied with jumper “JR” in the “F” position which connects the “RTN” and “COM” terminals together. **Note: Control will not operate unless jumper “JR” is in the “F” position.**

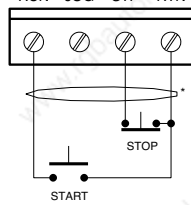
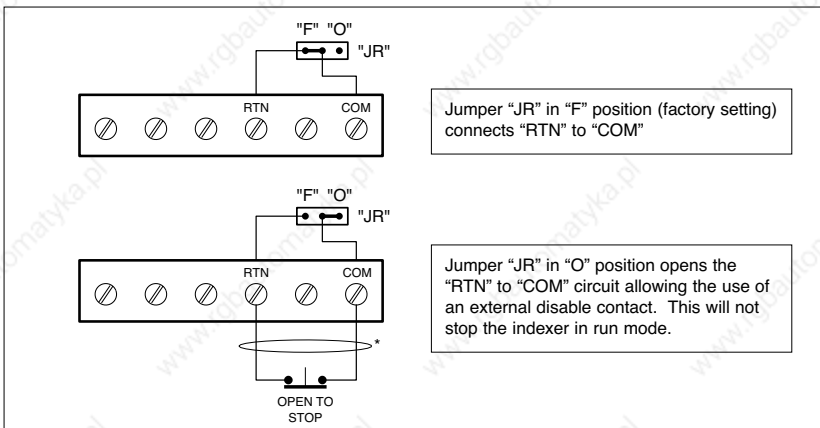
VII. APPLICATION WIRING DIAGRAMS

Example 1: Solid-state switching devices, such as NPN transistors or proximity switches, may be used for logic commands if they meet the following criteria:

¹Output voltage provided can vary between 20 and 24 Volts DC.

Capable of switching 30 VDC, at 24 mA, with an off-state leakage current of less than 1 mA. (See figure 12.) **Warning!** Do not ground or short +24V to COM or return on TB1. Do not use +24V for other than open collector sensors. (See figure 12.)

Example 2: For optimum operation, contacts used on logic inputs should be rated for low-level logic switching (i.e. gold contacts). (See figure 13.)

Example 3: “Cycle on Demand” – Important Information

In a “Cycle on Demand” application, the CAMCO Index Drive will make one complete cycle of movement of table or conveyor and then dwell until it receives an external signal from the machine’s controller or operator to start again. If motor receives a signal to start while the CAMCO Index Drive is in its dwell position, the motor will accelerate from a paused position to full speed during one half of the dwell of the main index cam. When the motor has reached its maximum speed and is no longer accelerating, the motion of the CAMCO Index Drive can start. As the Indexer re-enters its dwell portion of the main cam, the signal cam located on the camshaft of the CAMCO Index Drive will actuate the limit switch to signal a stop. (Note: Due to time delays, the signal cam may have to signal a stop some degrees before the index drive actually enters the dwell.) It is important that the motor is made to stop while in the dwell of the main cam. Stopping in any other position could damage the control or the Index Drive! Read all the instructions carefully in order to familiarize yourself with your new CAMCO Index Drive. (See figures 14A, 14B and 14C.)

FIGURE 12 – SOLID STATE SWITCHING

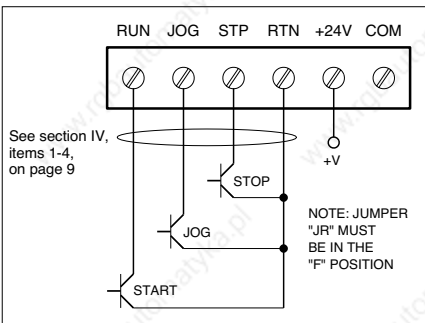

FIGURE 13 – CONTACT SWITCHING

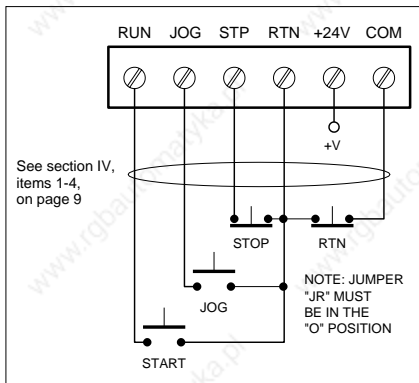
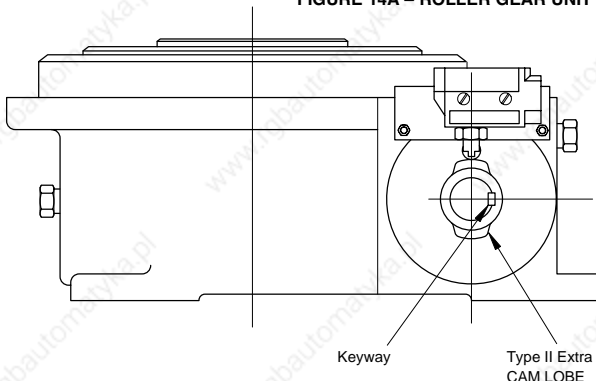

FIGURE 14 – CORRECT KEYWAY POSITION FOR CAM & LIMIT SWITCH ASSEMBLIES

FIGURE 14A – ROLLER GEAR UNIT



A standard Roller Gear unit with the CAM & Limit Switch mounted on the correct keyway position directly opposite of the output shaft, 90° (clockwise) from the CAM Lobe. The CAM & Limit Switch may also be mounted on the reducer. If the unit has a “Type II” motion, a special Limit Switch CAM is needed with one extra Lobe, 180° from the first Lobe (as shown). **Note: On some RDM units (such as the 601 RDM), the CAM & Limit Switch is mounted at an angle.**

FIGURE 14B – RIGHT ANGLE UNIT

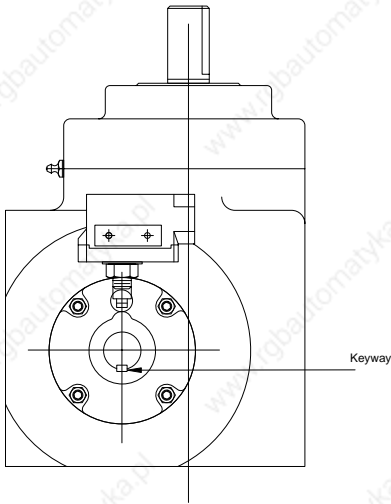

A standard right angle unit with the CAM & Limit Switch mounted on the housing has a correct keyway position directly opposite of the CAM Lobe. CAM & Limit Switch may also be mounted on the reducer.

FIGURE 14C – PARALLEL UNIT

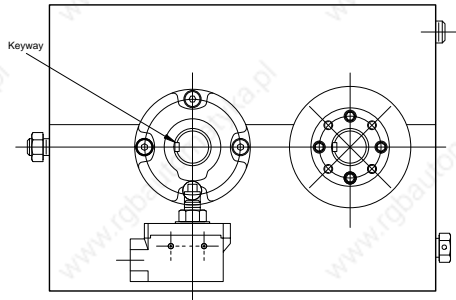

A standard parallel unit with the CAM & Limit Switch mounted on the housing has a correct keyway position directly opposite of the output shaft, 90° (clockwise) from the CAM Lobe. CAM & Limit Switch may also be mounted on the reducer.

The "Cycle on Demand" function is required for most indexing table applications. The control can be easily set for this operation as follows:

1. Jumper "JW" must be in the "R" position (factory setting) see table 6, on page 12.
2. Jumper "JR" must be in the "F" position (factory setting) see section VI D, on page 11.
3. Wire limit switch LS1 (normally closed) and start switch (normally open) as shown.

The "Cycle on Demand Operation"

begins with limit switch LS1 riding on the CAM lobe. (Since LS1 is a normally closed switch, it will be open when riding on the lobe.) The cycle is initiated by momentarily closing the start switch. The drive will start even though LS1 is open.

(Jumper JW is in the "R" position giving priority to the start switch which overrides the stop.) As the camshaft rotates, it moves off LS1 which closes. When the lobe rotates around back to LS1, LS1 now opens and the drive stops. The drive is now ready to repeat the cycle by initiating another start command. See figure 16, on page 15.

Note: A normally open (NO) STOP contact can also be used. To convert to a normal open STOP, move jumper JS from the factory position "NC" to position "NO."

FIGURE 15 – CYCLE ON DEMAND WIRING

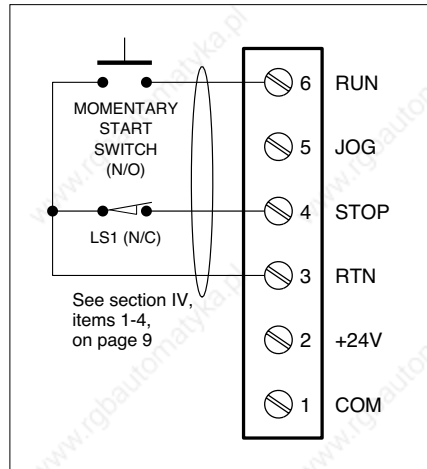
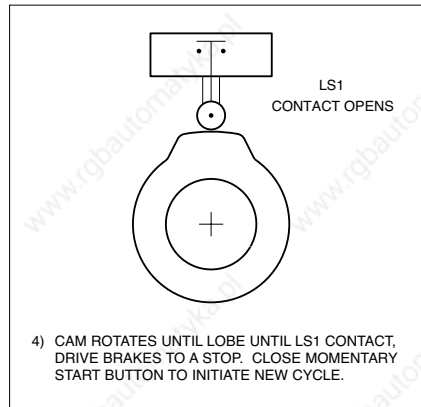
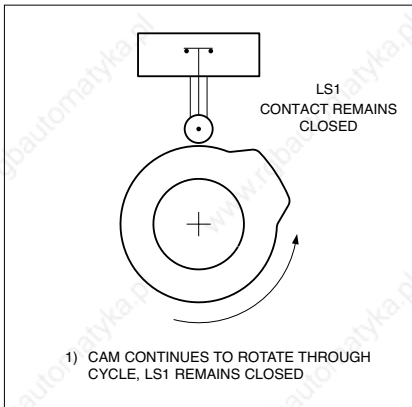
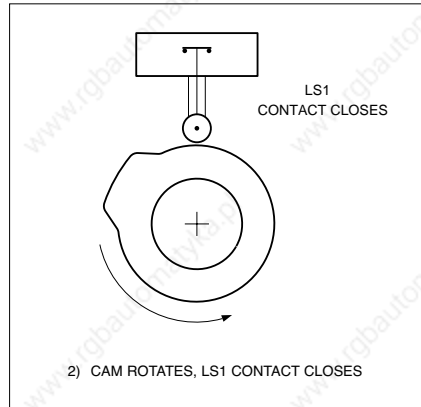
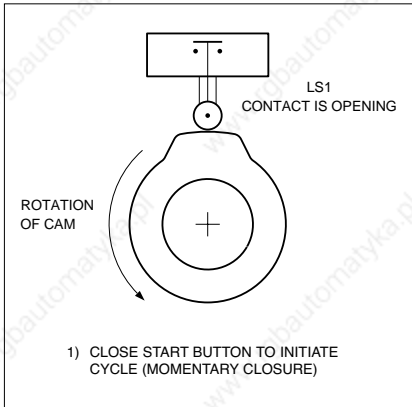

FIGURE 16 – SEQUENCE OF CYCLE ON DEMAND OPERATION



VIII. APPLICATION WIRING DIAGRAMS (Reversible Models)

P/N 92A61633020000 (120 VAC) – P/N 92A61633040000 (240 VAC).

Reversing models carry out the same functions as the unidirectional models except they can be made to index in both the forward and reverse direction. A special circuit APRM® provides a lockout feature that prevents catastrophic damage to the drive if a “Reverse” command is given during “Forward” operation (and vice versa). The reversing drives contain two additional positions on the terminal block: “Run Rev” and “Jog Rev.” The stop logic command is made with a normally closed (NC) contact.

Note: The sense of the stop logic can be changed from normally closed (NC) to normally open (NO) by placing jumper JS in the “NO” position.

The wiring diagrams on page 16 illustrate typical logic circuits. Many other configurations are possible. Consult factory if help is needed.

IX. OPERATION



WARNING! Read Safety Warning on page 2 before attempting to operate the control or severe injury or death can result. Failure to follow the Safety Warning Instructions may result in electric shock, fire or explosion.

FIGURE 17 – REVERSING LOGIC WIRING DIAGRAMS

FIGURE 17A – GENERAL CONNECTION DIAGRAM

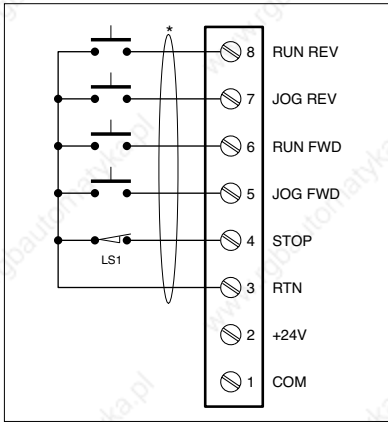

FIGURE 17B – REVERSING USING EXTERNAL CONTACTS

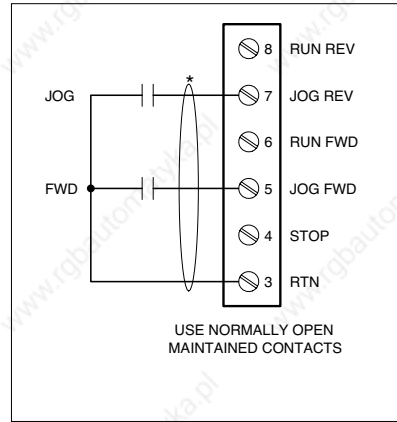

FIGURE 17C – CYCLE ON DEMAND WITH REVERSE

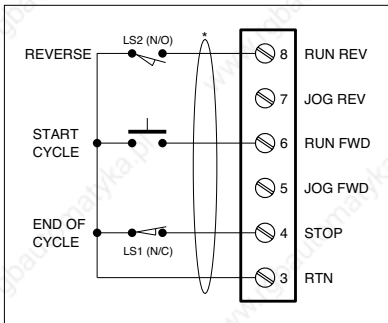
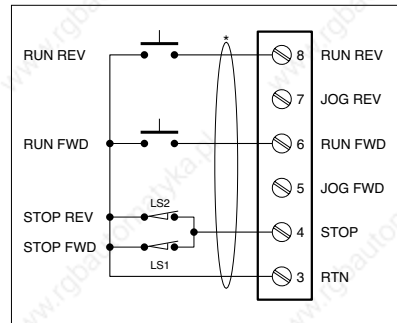

FIGURE 17D – FORWARD AND REVERSE CYCLE ON DEMAND



*See section IV, items 1-4, on page 9.

After the control has been set up properly (the jumpers set to the desired positions and the wiring completed), the start-up procedure can begin. If AC power has been properly brought to the control, the “ON” and the “STOP” indicators will be lighted. Before initially starting, be sure the main potentiometer is set to approximately 15% rotation. To start the control, move the Run-Jog/Stop Switch to the “Run” position and release. The “Stop” indicator should extinguish and the motor should rotate as the potentiometer knob is rotated clockwise.

Note: If the motor rotates in the wrong direction, it will be necessary to disconnect the main AC power and reverse the armature wires. To stop the motor, move the Run-Jog/Stop Switch to the Stop position. If power is lost the control will not restart, unless the Run- Jog/Stop Switch is moved to the “Run” position.

X. TRIMPOT ADJUSTMENTS

The control contains trimpots which have been factory adjusted for most applications. Figures 2A and 2B, on pages 4 and 5, illustrate the location of the trimpots and their approximate adjustment positions. Some applications may require readjustment of the trimpots in order to tailor the control to exact requirements. (See table 2, on page 4, for range and factory setting of trimpots.) Readjust trimpots as follows:



WARNING! Do not adjust trimpots with main power on if possible. If adjustments are made with power on, insulated adjustment tools must be used and safety glasses must be worn. High voltage exists in this control. Electrocutation and/or fire can result if caution is not exercised. Safety Warning on page 2 must be read and understood before proceeding. Failure to follow the Safety Warning Instructions may result in electric shock, fire or explosion.

A. Minimum Speed (MIN) – The MIN trimpot is used to set the minimum voltage of the drive. This sets the minimum speed of the motor. Adjust the MIN trimpot as follows:

1. Rotate Main Potentiometer to minimum speed position (full counterclockwise).
2. Increase setting of MIN trimpot so that motor runs at desired minimum speed.

B. Maximum Speed (MAX) – The MAX trimpot is used to set the maximum voltage of the drive. Adjust the MAX trimpot as follows:

1. Rotate Main Potentiometer to maximum speed position (full clockwise).
2. Adjust MAX trimpot setting to desired setting of motor speed.

C. Current Limit (CL) – This trimpot is used to set the maximum amount of DC current that the motor can draw. The amount of DC current determines the amount of motor torque. The CL trimpot is factory set at 150% of the current established by the jumper J1 selection. Readjust the CL trimpot as follows:

1. Turn CL trimpot to minimum (CCW) position. Be sure jumper J1 is in proper position approximately equal to the motor DC ampere rating. (See section III, on page 8.)
2. Set the main potentiometer at approximately 30 – 50% rotation.
3. Wire in a DC ammeter in series with armature lead. Lock shaft of motor.
4. Apply power. Rotate CL trimpot CW until desired CL setting is reached (factory setting is 1.5 times rated motor current).

CAUTION:

1. **Adjusting the CL above 150% of motor rating can cause overheating and demagnetization of some PM motors. Consult motor manufacturer.**
2. **Do not leave the motor in a locked condition for more than a few seconds since armature damage may occur.**

D. IR Compensation (IR) – The IR Comp circuit is used to stabilize motor speed under varying loads. Readjust the IR trimpot as follows:

1. Run the motor at approximately 30-50% of rated speed under no load and measure actual speed.
2. Load the motor to rated current. Rotate IR trimpot so that the loaded speed is the same as the unloaded speed measured in 1.

Control is now compensated so that minimal speed change will occur over a wide range of motor load. (**Note: Too much IR Comp will cause unstable [oscillatory] operation.**)

XI. FUNCTION INDICATOR LAMPS

The control contains three LED Indicator Lamps on the front cover that reflect its operational status.

A. Power On Indicator (ON) – This lamp will glow GREEN when the AC line is connected to the control.

B. Stop Indicator (STOP) – This lamp will glow YELLOW when the control is placed in the STOP mode with the Run-Jog/Stop Switch or logic contact.

C. Overload Indicator (OL) – When the motor is loaded to the current limit setpoint (CL setpoint is established by the setting of jumper J1 and the CL trimpot) this lamp will glow RED. If the OL indicator remains lighted during control operation, a fault condition may exist. Possible causes for this condition are as follows:

1. Motor is overloaded - check motor amps with DC ammeter in series with armature.
2. Motor may be defective - check motor for shorts or grounds.
3. The CL may be set too low - check position of jumper J1 and CL trimpot.

Note: In some applications, especially those requiring the motor to cycle on and off or from one speed to another, the OL indicator may blink indicating a transient overload. This is a normal condition for the application.

XII – TROUBLESHOOTING GUIDE

MOTOR WILL NOT RUN:

1. Check control operation by placing RUN - JOG/STOP in RUN position.
2. Make sure disconnect fuses or circuit breaker in AC line are okay.
3. Check fuse on PC board, and if open, replace.
4. Check logic. See Start-up Procedures and Application Section.
5. Be sure speed pot is not set at zero.
6. Unit is in current limit – See if “OL” indicator is lighted. Check position of jumper J1. (See table 4, p. 8) and CL trimpot setting.
7. With power removed from unit and motor leads disconnected, check for worn or improperly seated brushes.
8. Check for locked motor shaft.
9. Contact Industrial Motion Control.

FUSE BLOWING:

1. Improper wiring – check AC line and motor wiring. Be sure ground wire is connected only to the Green ground screw.
2. Improper AC line voltage. Be sure 120 Volts AC is connected to 120 Volt AC rated controls and 240 Volts AC is connected to 240 Volt AC rated controls.
3. Motor brushes worn or improperly seated.
4. Motor load is too heavy. Check for machine “jam-up” or excessive load. (“OL” LED is continuously lighted.)
5. Contact Industrial Motion Control.

BRAKING NON-FUNCTIONAL (control may not stop):

1. Improper logic wiring.
2. Motor brushes worn or improperly seated.
3. Contact Industrial Motion Control.

NO SPEED CONTROL:

1. Speed pot miswired or wiring defective.
2. Control not set up properly (see Application Section).
3. Contact Industrial Motion Control.

MOTOR WILL NOT RUN AT 1725 RPM:

1. Improper setting of Max SPD trimpot – rotate pot clockwise to increase speed.
2. Unit is in current limit (“OL” LED is lighted). (See section X, C, on page 17.)
3. Low line voltage. Check AC line voltage: 115VAC $\pm 10\%$ or 230VAC $\pm 10\%$.
4. Verify motor nameplate voltage complies with control output voltage rating.
5. Contact Industrial Motion Control.

– NOTES –



INDUSTRIAL MOTION CONTROL, LLC
1444 SOUTH WOLF ROAD
WHEELING, IL 60090 USA
Tel: 847-459-5200 Toll-Free: 800, 645-5207

FERGUSON