



USER'S MANUAL

Weld334m

PSA

PSC

PSM

GF WELDING S.p.A.

Strada del Portone, 18/24 – 10137 – TORINO (Italy)

Tel.: 011-3033.278 (Commercial Italy)
011-3033.270-279 (Commercial Foreign)Tel.: 011-3033.277 (Service Italy)
011-3033.274 (Service Foreign)

Fax: 011-3092046

e-mail: mail@gf-welding.itweb: www.gf-welding.it

The information contained in this manual may be changed at any time without prior notice; in this case, GF Welding S.p.A. is relieved of any responsibility.

The information on the software and hardware tools contained herein are confidential and are released in conformity with a licence contract.

It is absolutely prohibited to distribute or circulate the hardware and software documentation of this product to third parties.

The purchaser is allowed to prepare the software safety backup copy in the quantity of one copy only.

No part of this manual may be reproduced or distributed in any form or by any means or stored in a database or retrieval system without the prior written permission of GF Welding S.p.A.

All rights reserved to GF Welding S.p.A.

Table of contents

1. SAFETY	1
1.1 HAZARDS ASSOCIATED WITH THE USE OF RESISTANCE WELDING MACHINES	1
1.1.1 ! Prohibitions.....	1
1.1.2 ! Conditions to be respected to reduce the hazard	1
1.1.3 ! Causes of hazard.....	2
1.2 OBSERVATIONS ON CONNECTIONS.....	3
1.2.1 Earthing, insulation.....	3
1.2.2 Safety criteria against short circuits	3
1.2.3 Current sensor.....	4
1.2.4 Power supply.....	5
1.2.5 Phase synchronising for welding.....	5
1.2.6 Programming unit	6
1.2.7 Connecting the Weld334m with the WMS central network	6
2. CHARACTERISTICS AND GENERAL DESCRIPTION OF THE WELD334M	7
2.1 GENERAL DESCRIPTION	7
2.2 BLOCK DIAGRAM OF 334M	7
2.3 HARDWARE CONFIGURATION.....	8
2.4 CHARACTERISTICS.....	9
2.4.1 Utilisation characteristics	10
2.4.2 Dimensions, overall dimensions and fastening positions.	10
2.4.3 HHT4300 programming unit.....	11
2.4.4 Connection through Laptop	11
3. POWER SUPPLY AND 24V FOR I/O	12
3.1 CONTROL DEVICE POWER SUPPLY.....	12
3.1.1 PS . Description of signals	12
3.1.2 Connections for main power supply.....	13
3.1.3 Power consumption	14
3.2 USE OF 24V - I/O	14
3.2.1 Selecting 24V – internal or external.....	14
3.2.2 24V connections for discrete I/O.....	15
3.3 GENERAL PROTECTIVE DEVICES ON POWER SUPPLY.....	17
3.4 SETTING THE EXTERNAL SYNCHRONISM	17
4. F351-BUS INTERCONNECTION CARD	19
5. F384-CPU MICROPROCESSOR CARD	20
6. F353-ADC ANALOGUE CARD	22
6.1 P3 E P4 . DESCRIPTION OF THE ANALOGUE INPUTS	22
6.2 P2 . DESCRIPTION OF THE SIGNALS FOR THE SOLENOID VALVE AND THE TFE	23
7. F364-SEV AND F385-SEV: PROPORTIONAL SERVOVALVE MODULES	25
7.1 SERVOVALVE ADJUST:	25
7.1.1 Voltage outlet characteristics.....	26
7.1.2 Current outlet characteristics.....	26
7.2 CONNECTION OF THE F364 / F385-SEV MODULE ON THE F353-ADC CARD.....	26
7.2.1 Jumper function on connector J4	27
7.2.2 Jumper function on connector J5	27
8. F392-IOB BASIC I/O CARD.....	28
8.1 WELD YES/NO SELECTOR	28
8.2 P20 POWER SUPPLY.....	28
8.3 P22 HSA - CIRCUIT BREAKER RELEASE	28
8.4 P44 . INPUT-OUTPUT.....	29

9. F393-IOE I/O EXPANSION CARD	32
9.1 P42 . DESCRIPTION OF THE OUTPUT SIGNALS.....	32
9.2 P43 . DESCRIPTION OF THE INPUT SIGNALS.....	35
9.2.1 <i>Program selection code table</i>	38
10. F359-MCP MEMORY CARD AND PRINTER	39
11. F397-PDP PROFIBUS-DP	40
11.1 CHARACTERISTICS.....	40
11.2 PROFIBUS-DP.....	40
11.2.1 <i>P14 - serial port</i>	40
11.2.2 <i>TXD-RXD led</i>	40
11.2.3 <i>ADDRESS selector</i>	40
11.3 CARD LAYOUT.....	41
12. F381 ETHERNET MODULE WITH KEY	42
12.1 P10 ETHERNET 10BASE-T CONNECTOR.....	43
12.2 CONNECTION CABLES.....	43
12.2.1 <i>Characteristics</i>	43
12.2.2 <i>Type of connection</i>	43
13. PROFIBUS DP PROFIL F-PDP/01	44
13.1 GENERAL DESCRIPTION.....	44
13.1.1 <i>Control Word</i>	45
13.1.2 <i>Status Word</i>	50
APPENDIX	1
APPENDIX A - MAINTENANCE.....	2
<i>Maintenance operations</i>	2
Replacing the modular cards.....	2
Replacing the CPU card.....	3
Replacing the power feeder.....	3
Replacing the welding control device.....	4
Modifying a welding program.....	4
Replacing the battery.....	5
APPENDIX B – DIAGRAMS AND NETWORK CONFIGURATIONS.....	6
<i>Operating diagrams</i>	6
1 – START recognition with use in automated environment.....	6
2 – START recognition with use in manual environment.....	7
3 – EMERGENCY STOP condition : general diagram.....	8
4 – EMERGENCY STOP condition during or outside the welding pulse.....	9
5 – EMERGENCY STOP excluded with START still active.....	10
6 – START disabled condition during the welding pulse.....	10
7 – Proportional Servovalve operating diagram.....	11
8 – ENABLE function (Interbus-s).....	12
9 – Diagram of diagnostic pressure control.....	13
<i>Interbus-S – general architecture of I/O communications</i>	14
Ethernet Tcp/Ip – Example of network architecture.....	15
InterBus-S- Example of network architecture.....	16
APPENDIX C - WELD334M APPLICATION DIAGRAM.....	17

1. Safety

To insure correct installation and operation of the WELD334m welding control device, it is necessary to carefully read this chapter. Each operation on the machine is to be carried out only by qualified personnel with good understanding of the information contained in this manual; should the documentation not be perfectly legible and/or incomplete of any further information required, please consult GF Welding before undertaking any work on the machine.

Inside the welding control, signals are generated which set parts of the machine in motion; therefore, it is prohibited to open and tamper with the control and safety circuits. Live metal parts, such as screws or similar parts, penetrating into the electric circuit may cause malfunctioning as well as the generation of incorrect and hazardous conditions and events.

It should be remembered that any changes and/or modifications not expressly authorised by the manufacturer or performed by unauthorised personnel or non-GF Welding personnel which modifies the machine operation makes the warranty void.

Check all cables and the relevant connections before using the welding control device in order to see if there is any mechanical damage or failing insulation. Whenever a problem arises such as to compromise the safety conditions, switch off the unit and cut out power. Report the problem to GF Welding **After Sales Personnel.**

To ensure the optimal performance of the device, the user must make sure that all requirements for safety on the work site are strictly adhere to.

1.1 Hazards associated with the use of resistance welding machines

Because of the presence of electric current and live parts in the machine, mounting, maintenance work and replacement of genuine parts is only to be entrusted to Qualified Personnel (electricians or authorised personnel). All work undertaken is to be done in safety conditions. The non-observance of these requirements can cause death, injury to persons or damage to machine and property.

1.1.1 ! Prohibitions

- It is prohibited to work on the live installation.
- It is prohibited to remove by-pass and modify the safety devices as this could cause serious risks to personnel and equipment and could lead to death.

1.1.2 ! Conditions to be respected to reduce the hazard

- Always insure that the electric switchboard main switch is OFF.
- Work on the machine, equipment and the welding transformer only after breaking the connection from the mains. This to be sure that no undesired switching of electrical current occurs.
- Work on the spotgun and welding cable connections only after breaking the connection from the mains power.

1.1.3 ! Causes of hazard

- The programming of the welding control is entrusted only to qualified personnel. Incorrect parameter settings may cause damage or injury because of undesired molten material splashes during welding. It is compulsory to wear protective goggles, non-flammable clothes and protective shoes.
- Dangerous conditions may arise when, for example, electrodes are changed or dressed and no current re-adaptation/re-setting takes place, especially when using the stepper function (stepper reset).
- If 24V power supply is external to the machine or the control device, power may be applied to the equipment even if the main switch connection is broken.
- During mounting, setting of work, maintenance and/or repair operations, hazards may occur because of the exchange of leads, air/water pipes, etc...
- Unqualified personnel may be unaware of the risk that such changes/modifications entail, therefore, all changes/modifications are only to be entrusted to and/or performed by qualified personnel.
- Hazardous situations may arise because of mains voltage drops, or in case of tripping of the machine emergency stop device, which causes the return to rest position of the pneumatic valves in use during the operation (this situation affects the whole plant).
- If during the welding process the cooling water flow is low or non-existent, it is prohibited to bypass or inhibit the tripping of thermostats or the water flow control device (if installed).
- High magnetic fields, generating very close to the welding gun and the secondary cable, represent a serious hazard to people and property (e.g.: watches, cables for electric data transmission, magnetic devices, medical equipment and pace-makers).
- Welding is obtained through the periodical repetition of high single-phase, short-time and low cosphi current pulses. These conditions of use may cause disturbances to the power lines of the production plant and may be hazardous for other types of operating machines or machine tools.
- Outputs of the welding control device solenoid valves are all protected by a series-connected contact of the cycle start relay. This to prevent any faults or disturbances of the electronic outputs from causing undesired controls. (The Start cycle function is equipped with a time-dependant consent control at the plants and countries demanding for it).
- In cases where local safety regulations require or prescribe such as for machine start – for instance: two-hand cycle start controls with check of simultaneous operation – these devices shall have to be implemented when installing the system.
- Outputs for the pre-stroke solenoid valves controlling the additional gun opening, feature direct control as well as the output for the proportional solenoid valve.
- These two outputs do not cause any movement nor do they operate the gun to close fully.

1.2 Observations on connections

1.2.1 Earthing, insulation

This paragraph deals with the earthing of the equipment, please ensure that all earthing is correctly carried out.

- The correct earthing of each part of the electric system is a compulsory precaution, in order to ensure the plant workers/operators safety.
- Furthermore, earthing is of paramount importance to avoid damage to the installation itself. Periodically check the status of earth connection of all cables and terminal cards.
- Special care is to be paid to connections with moving and metal parts, making sure there is no oxidation of connection and that the electrical connections are made against painted areas.
- To have correct earthing, it is fundamental to avoid series connecting the whole earth installation or part of it with only one cable. It is also important to check that, for each machine, the earth is star connected at the fixing point of the earth cable.
- Some types of welding machines need for the earth connection of the transformer secondary to be made outside of the machine.
- The Weld334m is a sophisticated, microprocessor controlled equipment which can also be used in environments showing «electromagnetic field pollution». In the design phase, systems have been adopted which respect the EMC requirements with the surrounding ambient. It is recommended to scrupulously observe the conditions of use (meaning by this that the Weld334m cabinet is to be closed and all its earth leads must be connected).
- In compliance with the accident prevention Standards, the welding control does not act directly on the SCR block; the SCR switching is operated through a special external firing circuit which is isolated from high voltage present on the power circuit.

1.2.2 Safety criteria against short circuits

On a welding machine, the short circuit is likely to occur on the transformer primary side. This may entail very serious consequences such as, for example:

- On a Robot or an automatic installation, the destruction of parts onto which the short circuit current is discharged.
- On a manual station, the electrical shock of the operator and damage to the equipment.

The short circuit may occur between the primary and ground or between the primary and the secondary.

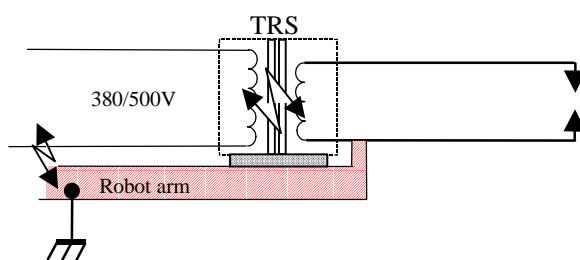

Here below are a few measures which are to be taken in order to avoid harm and damage to operators and equipment:

1. Earth the welding transformer secondary.
2. Install a differential on the welding transformer primary set to the minimum value of current (30mA).

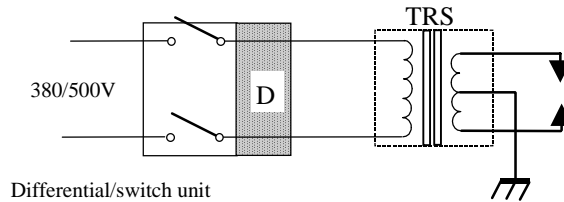

3. Use a safety device to monitor the value of voltage on the welding guns with respect to earth. This device should be linked to circuit breaker trip.

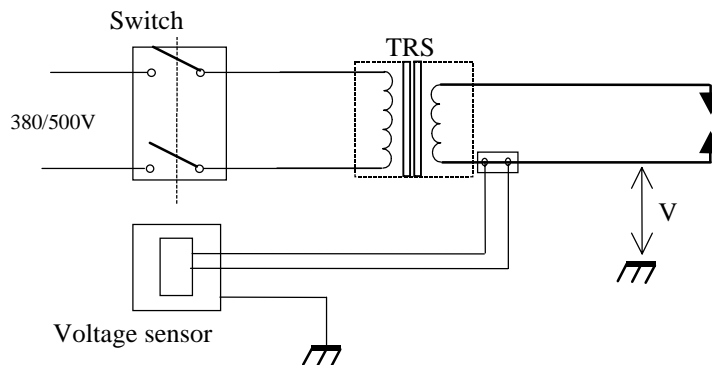

1.2.3 Current sensor

The current sensor, also known as current coil or Rogowsky coil, thoroid or, sometimes, more improperly, CT (current transformer), is the device by which the control device measures and adjusts the welding current during the welding process.

Irrespective of the specifications and standards of the electric transducer characteristics, a few fundamental rules are however to be applied concerning the position of the transducer and its relevant wiring. This to minimise errors due to electric and, mainly, magnetic disturbances.

The reliability and accuracy of the ammeter directly depend on the correct positioning as well as on the adequate protection against external disturbances.

If the sensor is built into the welding transformer, problems concerning the respect of a few of the Standards have already been solved in the transformer design phase.

As for sensor positioning, the following requirements are to be adhered to:

- The sensor is to be located in the welding secondary circuit.
- The plane to which the sensor is mounted must be orthogonal to the lead run through by current it measures, that is 90°.
- The sensor, if external to the welding transformer, must be placed as close as possible to the welding electrodes. Thus, maximum accuracy is achieved. However, this mounting position is not always possible. A good compromise lies in mounting the sensors in the rear part of the guns, near the cable adapter. Provide for protection against shocks. It can however be always placed at the transformer secondary output.

- The lead run through by current is to be placed in the middle of the thoroid.
- The sensor is to be placed as far as possible away from any edges or elbows of the secondary lead.
- As for the turn formed by the secondary circuit, it is necessary to mount the sensor in a position so that the distance between the go and return conductor be the maximum possible one.

As for the sensor connections, the following requirements are to be adhered to:

- The connection cable is to be tightly twisted and screened and is to be run as short as possible. In any case, its laying is to be done as far as possible away from sources of electrical or magnetic disturbances and it must not be run in parallel with the cable for welding component (primary + secondary).
- The cable screen must be bonded on only one side of the welding control, whereas no sensor end is to be bonded.
- Accurately avoid joints or provisional connections between the sensor and the connector of the welding control in order to minimise any inductive and capacitive effects. If possible, minimise the quantity of interruptions (terminal boards and/or plugs).
- Do not use fuses on the current sensor conductors.

The rules cited above are to be observed by all users carrying out installations and wiring as well as by those who design and manufacture electric switchboards in cabinets, transformers and other equipment which are somehow associated or associable to current sensors. The non-observance of these rules entails loss of accuracy and repeatability in the welding process with constant current control device. In addition, this could cause serious malfunctioning.

- It is recommended to use current sensors featuring 150 mV/kA /1k Ω sensitivity and with a 20-25 Ω internal resistor (these can be ordered from GF Welding S.p.A).
- The Weld334m permits using up to 6 sensors in series (one at a time is active when welding). The quantity of sensors connected is to be set on the welding device (see Programming manual, Setup chapter).

1.2.4 Power supply

Depending on the configurations, the Weld334m input can be both direct current and alternated current (See operating characteristics).

One assumes that power supplied to the system is «clean», meaning it is free from electrical disturbances and showing no voltage drops.

In case of AC, it is recommended to use a power/insulation transformer with earthed electrostatic shielding.

1.2.5 Phase synchronising for welding

To have correct welding operation, the device is to be synchronised with the same power phase as the SCRs it is piloting.

Considering the power supply features of the device, synchronising may take place in a different manner, depending on the following cases:

- If powered from the Ac mains, it is sufficient for the transformer powering the device to be connected with the same power phase as SCRs.
- If powered from a power line other than that of SCRs or DC powered, the sync. signal must be taken from the power side through an insulation transformer. For the use of the external synchronism, see paragraph 3.4

The non-observance of these rules will cause **serious malfunctioning**.

1.2.6 Programming unit

Great care is to be paid to the switching on and off of the HCM 4300 HHT graphic programming unit.

The input port can be damaged both because of a short circuit during the connection work and further to electrostatic charges. Put the HHT metal casing in touch with that of the Weld334m before installing the connector. This will discharge the static charge.

Make sure no foreign bodies, such as metal chips or slags, fall inside the connector.

Any damage to the HCM 4300 HHT graphic programming unit and to the Weld334m, resulting from tampering or deliberate disregard, will void the guarantee.

1.2.7 Connecting the Weld334m with the WMS central network

To centralise the welding zones, GF Welding has developed a program called WMS (Welding Management System). All control devices installed in a given welding zone can be accessed directly through a serial line linked to a PC.

The program permits interacting with all control devices and, at the same time, controlling the whole welding process of the zone concerned.

Communication is performed through: the WmsNet associated to an RS485 multidrop network, or PROFIBUS FMS or ETHERNET TCP/IP.

The serial port of the device has been designed to operate in industrial environment where a number of pulse and electric disturbances are present. To protect the input stages, these are fitted with disturbance suppression circuits, whereas the output stages provide signals ensuring nearly disturbance free level.

For the application of the welding control devices in the WmsNet, PROFIBUS FMS or ETHERNET TCP/IP centralising network, refer to the relevant specifications.

While implementing the line, a few practical requirements are to be observed by the user.

- Avoid long common paths of line cables with power cables. Do not forget this warning specially when planning the lines and the network.
- Limit the network cable length to the minimum required. (Respect the RS485, PROFIBUS or ETHERNET requirements for length).

In addition, the best results are achieved if the following is taken into consideration:

- Terminate the line as specified in the installation manual of the network card.
- Connect all controls with the network interface card (daisy connection) so to have only one line of transmission.
- The cable is to comply with the relevant RS485 or Profibus specifications.

2. Characteristics and general description of the Weld334m

2.1 General description

The Weld334m is a control device intended for single-phase AC powered, resistance welding machines. It is capable of managing all the operations run by the machine it is associated with; the Weld334m also provides adequate diagnostics for the plant and welding process and carries out welding current regulation by chopping the voltage applied to the power transformer.

The Weld334m can be field programmed via the HHT4300 graphic unit or, through the centralising network, via a remote computer equipped with the WMS software and the adequate communication card.

It permits running up to a maximum of 255 welding programs and 16 different self-increment programs (stepper). The internally mounted clock provides the correct absolute timing reference; this function is also available for the stand-alone utilisation, meaning with independent control.

The HHT4300 programming unit is removable, thereby preventing any interference of unauthorised personnel on the welding programs.

The operating frequency of the unit is 50Hz or 60Hz.

Facility is also provided to memorise and transfer data and programs through a commercially available PCMCIA type memory card.

The welding control interfaces with a number of equipment and actuators, e.g. welding solenoid valves, process controllers (PLC) and robots, by connecting with the field or with standard wiring or through a serial line (optic fiber) in conformity with the Profil-CO protocol of Interbus-S standard.

2.2 Block diagram of 334m

The 334m can be divided into two separate functional blocks.

The first block is the basic part of the system and consists of the main cards, which must always be installed, two internal fixed cards (power feeder and BUS) and three removable ones (CPU, I/OB and ADC).

The second functional block consists of the additional configuration card pack: I/O Expansion, Memory Card/Printer, EVS Proportional, Network.

Through these cards, the control device can:

- Be configured for advanced or special applications which are used in the resistance welding field
- Be upgraded with optional functions such as proportional solenoid valves or o memory card
- Manage a serial communication port to the welding central unit

The block diagram is shown below.

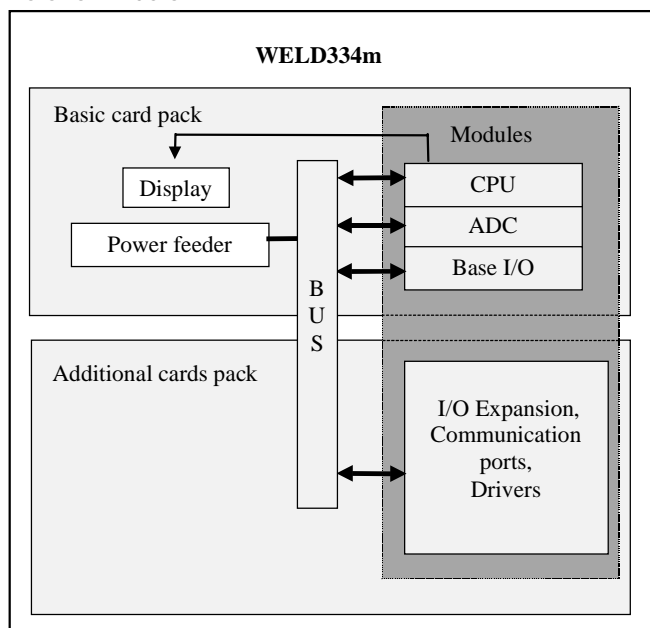

2.3 Hardware configuration

Every function has been housed on a dedicated card; in addition to this, 24Vdc discrete inputs and outputs are divided into Base and Expansion types.

The first position on the BUS, near connectors P1 and JP1, is to be compulsorily dedicated to the card CPU.

List of available cards:

Order code	Type	Card description										
		Power supply	BUS card	Display 4 arrows	C.P.U.	Analogica & SV	Proportional solenoid valve module	Basic I/O	Expansion Basic I/O	Memory-card+printer	Profibus DP	Ethernet card with Data Key
		Card name	Card order code									
		F370 PSM	33037000									
		F351 BUS	33035100									
		F363 DPY	33036300									
		F384 CPU	33038400									
		F353 ADC	33035300									
		F364 SEV	33036400									
		F392 IOB	33039200									
		F393 IOE	33039300									
		F359 MCP	33035900									
		F397 PDP	33039700									
		F381 ETH	33038100									
33030180	Weld334m PSA	X	X	X	X	X	X	X	X		X	X
33030190	Weld334m PSC	X	X	X	X	X	X	X	X			
33030194	Weld334m PSM	X	X	X	X	X	X	X	X	X		X

2.4 Characteristics

Control power supply:	Alternated current: min. 14,4Vac rms max.32,4Vac rms Direct current ⁴ : min.18Vdc ² max.36Vdc Protection: self-reset type ³	Voltages recommended: 27Vac +10/-15% ¹ 24Vdc +20/-15% ¹
24Vdc I/O total power:	24V internal: ±10% 1,5A max 24V External: -15%+20% 1,5A max 24V Interbus-S: -15%+10% Protection: self-reset type ³	
discrete digital I/O:	Inputs:	Voltage: 18-30Vdc Protections: Overvoltage (disturbances and peaks)
	Outputs:	Voltage: 24Vdc max 0,3A EV, EVS: 24Vdc max 0,3A Pulse Ctrl. : 24Vdc with 10 ohm 2W resistance in series for current limitation Protections: Short circuit Overcurrent Overvoltage (disturbances and peaks)
Programming port:	local: Serial type for GF Welding HHT4300 unit or Laptop PC (with WMS GF Welding software) On line: Serial, via the WMS centralising system (see optional)	
Current sensor input (TA): Analogue voltage input (TV): Analogue voltage input (TFE): External sync.: System program: No. Of Programs: Welding channels: Storage:	type 150mV/kA (adjustable) ±36V max ±36V max 12-33Vac On flash-eprom; it can be updated through the memory card 255 2 The storage and the internal clock are powered through a lithium battery with a surveying circuit of the battery charging status and Supercap for data holding when replacing the battery. The battery life depends on the operating conditions.	
Optional extras: Serial Card: Printer port: Port for external memory card: Proportional solenoid valve module:	Ethernet Tcp/Ip for WMS centralisation network Parallel, standard PCMCIA memory card 0-10V Voltage (with protection against short circuit) 4-20 mA current	

Notes:

1. IEC 1131-2 Standard
2. The value does not include the voltage ripple
3. See characteristics at paragraph 3.3
4. The external synchronism is to be used, see paragraph 3.4

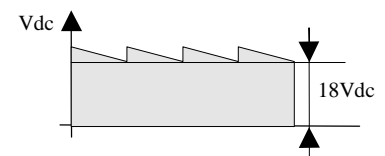

2.4.1 Utilisation characteristics

The construction complies with the EC requirements, CE marking

Operating temperature: 0° to +60°C, humidity 0 to 80% without condensation

Storage temperature: -40 to +80°, humidity 0 to 90% without condensation

Weight: 2.5Kg maximum (depending on the configurations)

2.4.2 Dimensions, overall dimensions and fastening positions.

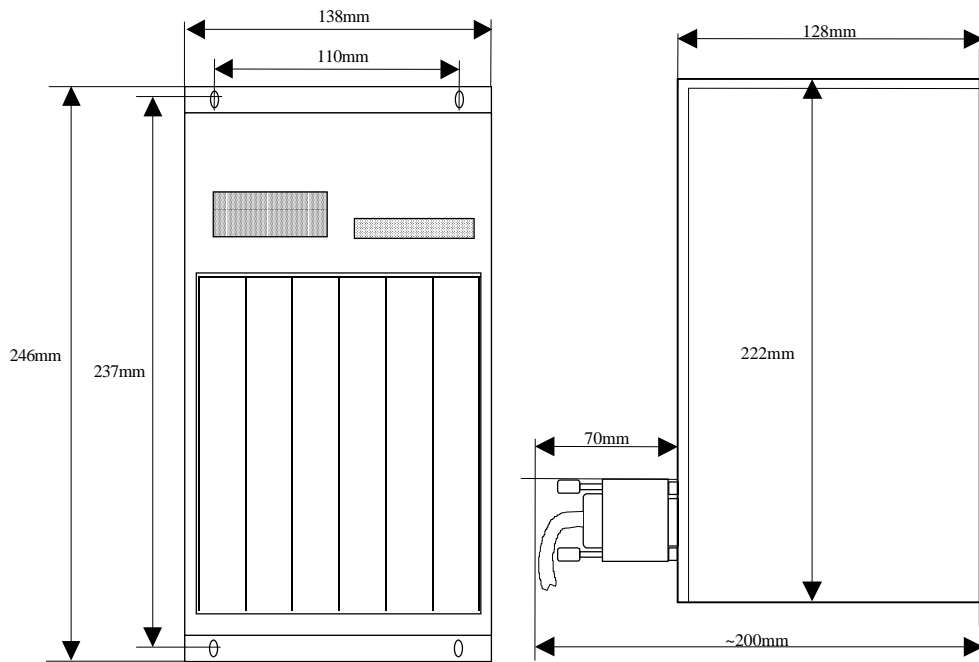

2.4.3 HHT4300 programming unit

The unit connects to the P1 connector of the control device and communicates through an RS485 Full duplex serial port.

It consists of a rectangular-shaped, 240x64 dot LCD display (8 lines – 40 characters consisting of 6x8 dots).

Touch sensitive keyboard with integral surface (bubble).

Keys layout: 4 arrows, enter (ENT), quit (ESC), +, -, 5 function keys.

Remote connection distance:

- With direct connection: 100m
- With indirect connection (separate power feeder): 600m

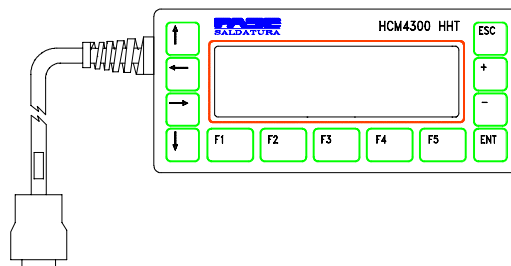

Dimensions: L=200mm, H=90mm, Pr=35mm

Operating temperature: 0° to +45°C with humidity from 0 to 80% without condensation

Storage temperature: -40 to +80° with humidity from 0 to 90% without condensation

Weight : ~500g

9-way, Sub-d socket connector

Pin	Signal	Description
1/6	OVH	Earth
2/7	+VH	HHT4300 programming unit power supply
3	N.C.	Polarising pin
4	RXD+	Data reception +
5	TXD+	Data transfer +
8	RXD-	Data reception -
9	TXD-	Data transfer -

2.4.4 Connection through Laptop

The Laptop connects to the P1 connector of the control device and communicates through an RS485 Full duplex serial port, with WMS rel. 2.61 and upgrades.

Cable for connection between Weld334m and PC laptop: F2118;

Order code: 32102110;

With converter RS485 / RS232;

L=2,5mt.

3. Power supply and 24V for I/O

3.1 Control device power supply

The power supply section resides on the PS 8way, 5.08mm pitch connector for disconnectable terminals which are located on the front. Also housed on this connector is the input for the external synchronism.

Either incoming direct current or alternated current is accepted by the control device (see characteristics at paragraph 2.4).

The control device earthing is to be carried out by means of the faston terminal located at the side of PS connector.

3.1.1 PS . Description of signals

8-way, 5.08mm pitch PS connector for disconnectable terminals

Pin	Signal	Description
1-2	PWR/RTN	<p>Main power supply of the control device.</p> <p>The device can be powered from either d.c. mains – from 18 to 36Vdc – and a.c. mains - from 14,4 to 32,4Vac – with no need for the user to change the connections or the internal settings.</p> <p>If powered from a d.c. source, the pin polarity is irrespective of this status.</p> <p>NOTE: if the unit is fed from a d.c. supply, the external synchronism must be used.</p>
3-4	SYNC +/-	<p>External synch signal.</p> <p>Sensitivity: 12-33Vac.</p> <p>It permits the synchronisation with power supply on the power side (SCR), through an insulation transformer connected to the same phase.</p> <p>This must be used when the unit is powered from a line separate than that of the welding machine or when it is powered from the d.c. mains.</p> <p>If used, this signal must be configured on the power feeder card through 2 jumpers (see paragraph 3.4).</p>
5	24VI	<p>+24Vdc output, internal.</p> <p>It is used when one wants to use +24V supply internal to the device for powering the I/O.</p> <p>It can be cut out for enabling 24V from a remote unit (Robot).</p> <p>For the connection, refer to paragraph 3.2.2 figure (b).</p>
6	24VE	<p>24Vdc external input for discrete, digital I/O.</p> <p>Max. Load 1,5A.</p> <p>For the connection, refer to paragraph 3.2.2 figures (c) and (d).</p>
7	0V	<p>Input for 0V external common for logic I/O.</p> <p>For the connection, refer to paragraph 3.2.2 figures (c) and (d).</p>
8		<p>Contact available for Earth connection.</p> <p>For the connection, refer to paragraph 3.2.2</p>

3.1.2 Connections for main power supply.

Diagrams for control device power supply are illustrated below.

- Ac input taken from the power line of the welding transformer.

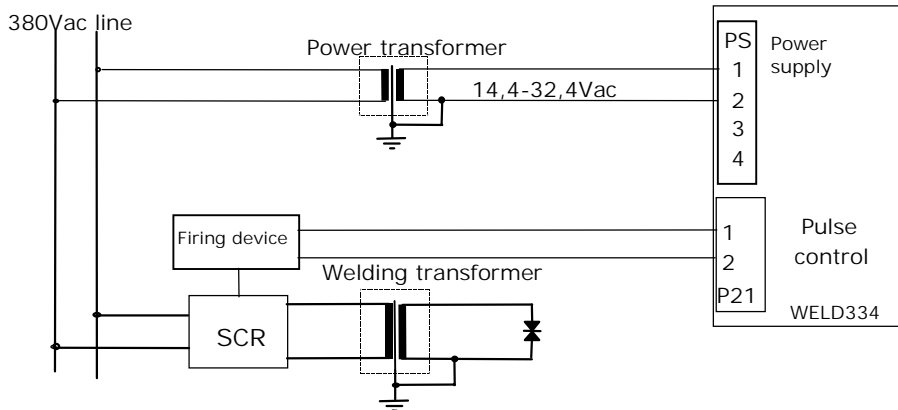

- Dc supply

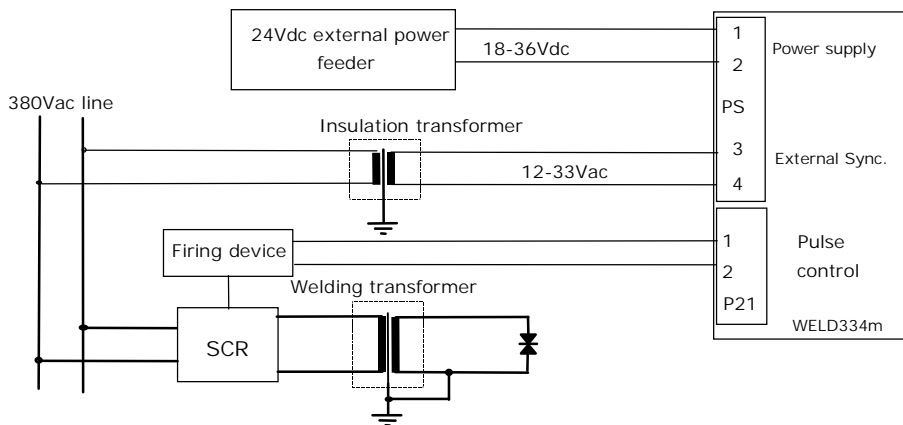

- Ac supply taken from a line separate from the welding transformer power supply.

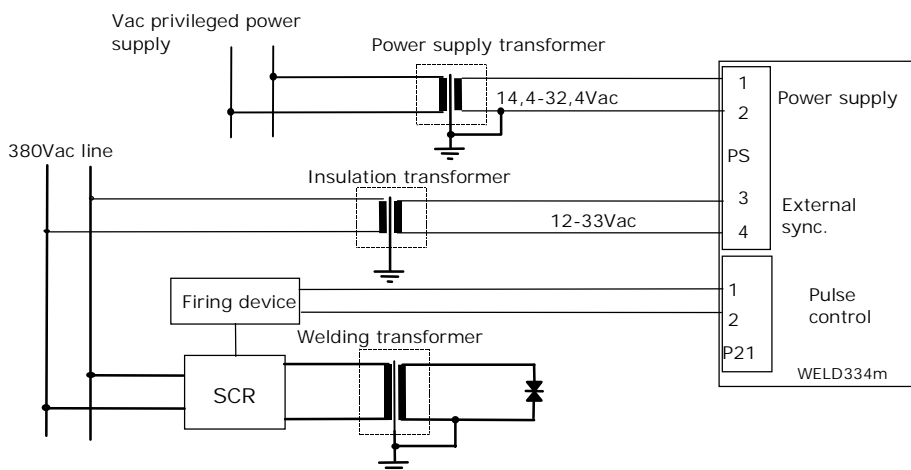

3.1.3 Power consumption

Power used is dependent on the type of application carried out on the machine.

Table below lists the minimum power to apply to the control device in its full configuration, depending on the type of power supply being used.

Power feeder	Power supply type	Consumption	
		24V Internal	24V External
F350/370	Vac Transformer (recommended):	110VA	62VA
F350/370	Vdc Power feeder (recommended):	80W	45W

3.2 Use of 24V - I/O

To make use of 24V supply of I/O, certain rules are to be observed. These rules depend on the type of application used on the machine.

The Weld334m is supplied by GF Welding in a standard configuration; 24V = make jumpers between pin 5 and pin 6 (see figure below).

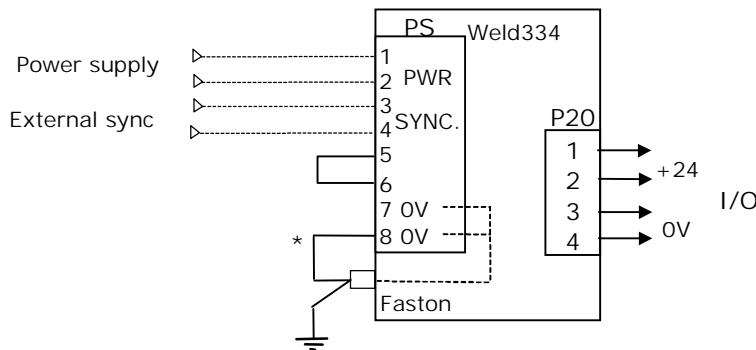

3.2.1 Selecting 24V – internal or external

24V supply for I/O input is distributed in such a way to have two internal separate lines. These lines are alternate between one another:

- One line for external 24V (24VE), whose input is located on pin 6 and pin 7 of PS
- One for internal 24V (24VI) which, from the power feeder, is connected directly to bus connectors JP2/3/4/5/6 (see figure 1).

Figure 1

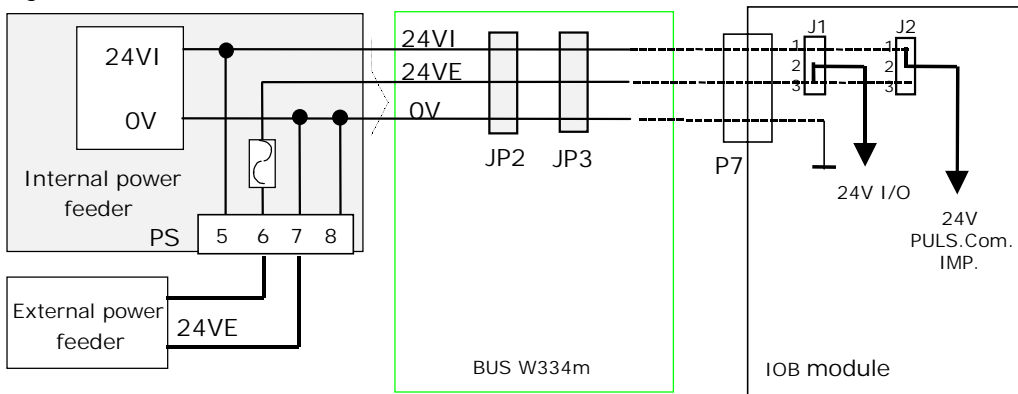

The modules using 24Vdc supply have 2 jumpers: J1 for 24V of I/O and J2 for 24V supply used for the pulse control or the servovalve. These jumpers allow +24V supply to be set toward the internal power feeder or toward an external +24V supply.

Each module is factory-calibrated (standard calibration) and calibration value is shown on the layout page in the chapter concerning each module.

Figure 1 gives an example of setting for these 2 jumpers.

24V I/O can be managed in the following ways:

- ◇ **Direct:** 24VI supply with pins 5 - 6 of PS being free (see paragraph 3.2.2 figure a) J1 connector: jumpers of I/O and ADC cards to be made in position 1-2.
- ◇ **Indirect :** 24VI supply with pins 5 and 6 of the PS: make jumpers or cut them out from a contact (see paragraph 3.2.2 figure b).
24VI supply, which in this way can be cut out from the outside (enabled/disabled), is re-closed on 24VE line.
- ◇ **External:** with external 24V supply connected to pin 6 and pin 7 of the PS (see paragraph 3.2.2 figures c and d).

Summary Table of 24V I/O jumpers of cards

24V Selection	J1	J2*
Internal	1-2	1-2
Internal indirect	2-3	1-2
External	2-3	2-3

* Where present

3.2.2 24V connections for discrete I/O

Figure a: Use of +24VI supply in direct way

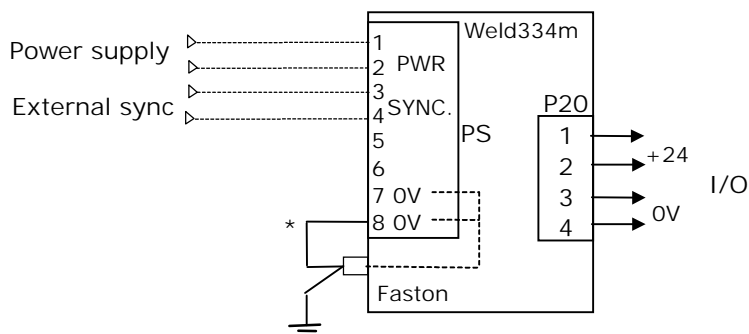
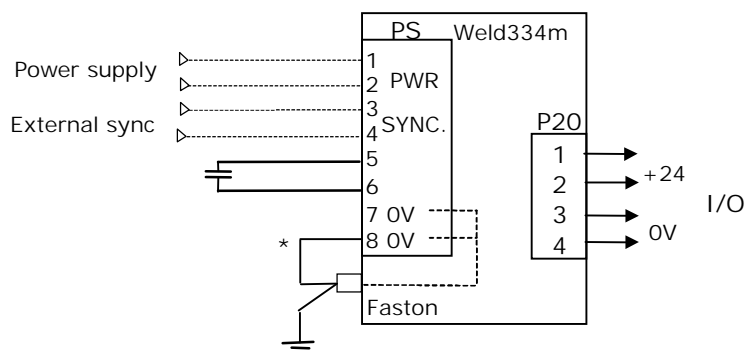
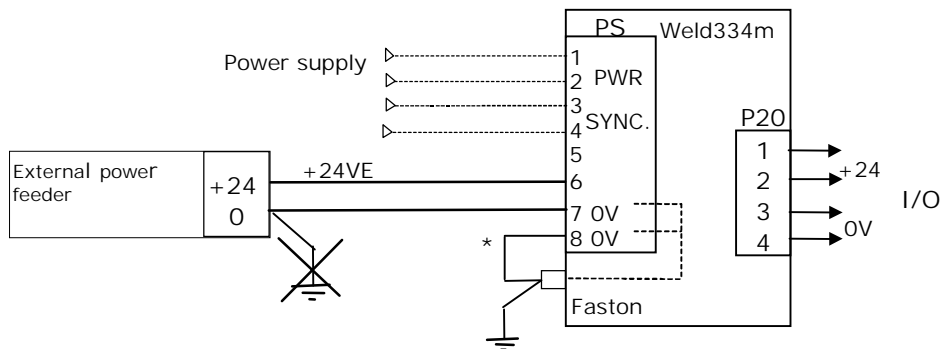

Figure b: Use of +24VI in indirect way



24VI is cut off on the PS between pin 5 and pin 6. Thus, 24V supply of I/Os can be enabled and disabled independently of the control device.

Figure c: Use of +24VE (external) with earth on the Weld334m side



If earthing for 24VE supply has been performed on the welding control device side, then the external power feeder is not to be earthed.

Figure d: +24VE with earth on the external power feeder side

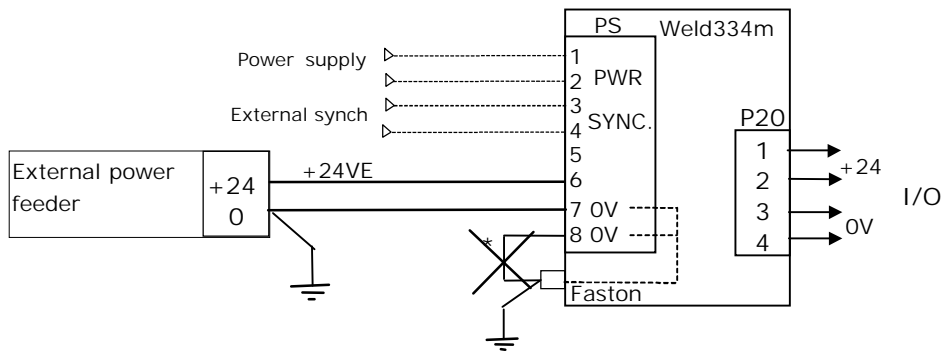

If earthing for 24VE supply has been performed on the external power feeder side, then the welding control device is not to be earthed.

- * The connection of pin 8 of the PS to the earth faston terminal is required only if the internal power feeder is of F350 type, if the internal power feeder is of F370 type, the link to the earth faston terminal is done internally and the connection between pin 8 of the PS and the faston terminal is not required.

3.3 General protective devices on power supply

General schematic of protective devices.

Protection A:

Voltage/current limit circuit placed on the power feeder primary

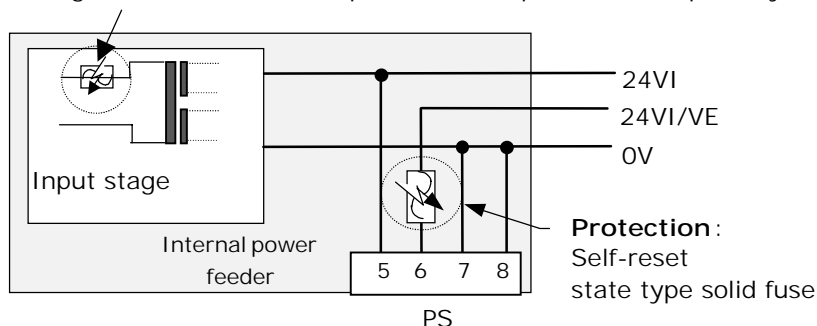

On the basis of the type of connection in use, the protections operate in the following way:

◇ **Protection A:** General overvoltage and overcurrent protective circuit .

This protective device trips in the following cases:

1. If, when switching on the device, the line voltage exceeds the hazard limit of rated ranges.
2. In all cases of internal short circuit, on the output of the pulse control or of 24V signal of the servovalve.
3. In case of overcurrent, if 24VI for I/O points is used both in the direct connection mode (see paragraph 3.2.2 figure a) and in the indirect one (see paragraph 3.2.2 figure b).

With this type of connection, the protective device **A**, which features a faster switching time, prevails on the device **B**.

In order to reset the functional conditions, it is necessary to cut off power and remove the cause of the short, then switch on the device again after about 30".

If by activating it again, the device does not switch On (**RUN** led indicator of CPU Off), then check that line voltage is correct and that it complies with the characteristics indicated (if not, the control device will stay off due to the protection device).

If all these conditions are observed but the device does not switch On, the power feeder is likely to be damaged. Replace it.

◇ **Protection B:** current limit circuit on the external 24V supply.

It intervenes in case of use of the external 24V supply for the I/O points (see paragraph 3.2.2 figure c).

Once the cause has been removed, the protection resets automatically.

Characteristics of current limitation as a function of temperature*.

Power feeder type F350-PSM

	Temperature* (°C)			
	20°	40°	50°	60°
Current (A)	3.75	3.04	2.70	2.36

Power feeder type F370-PSM

	Temperature* (°C)			
	20°	40°	50°	60°
Current (A)	2.5	2.03	1.8	1.58

* Characteristics refer to the operating temperature of the component itself.

3.4 Setting the external synchronism

For the firing pulse to the SCRs to be synchronised with the mains of the SCRs, the two jumpers for the line synchronism must be set on the card.

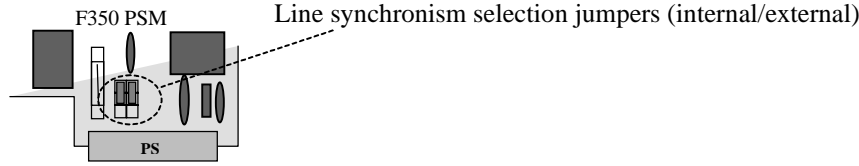

1. When the control device is powered from the a.c. mains taken directly from the power line of the SCRs, jumpers are to be set to PWR-RTN, (standard configuration).
2. If the synchronism signal is to be taken directly from the power group through an attenuation/insulation transformer, the jumpers are to be set on S1-S2. This configuration is compulsory when the device is powered from the d.c. mains.

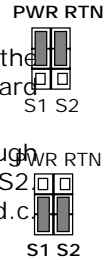

NOTE: The secondary of the insulation transformer is not to be earthed

Example of connection for the external synchronism

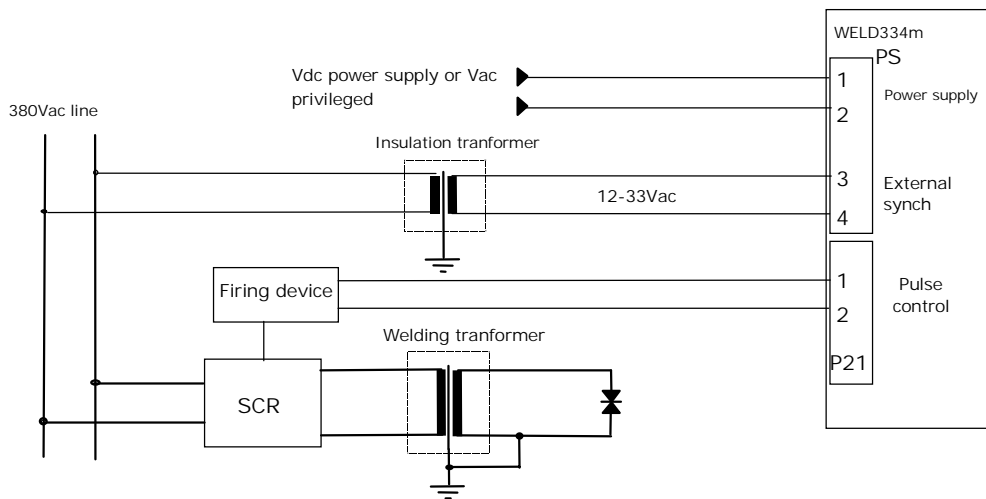

4. F351-BUS Interconnection card

BUS interconnection card for signals and power supply.

J2 connector takes 24V supply for the I/O power supply.

J1 connector takes 5V supply for the cards and +V for programming unit HHT.

JP1 connector is used to power the programming keycard (via CPU).

The connectors JP2, 3, 4, 5, 6 distribute 24VI and 24VE supply for the I/O points.

Connectors P1...6 form the digital BUS.

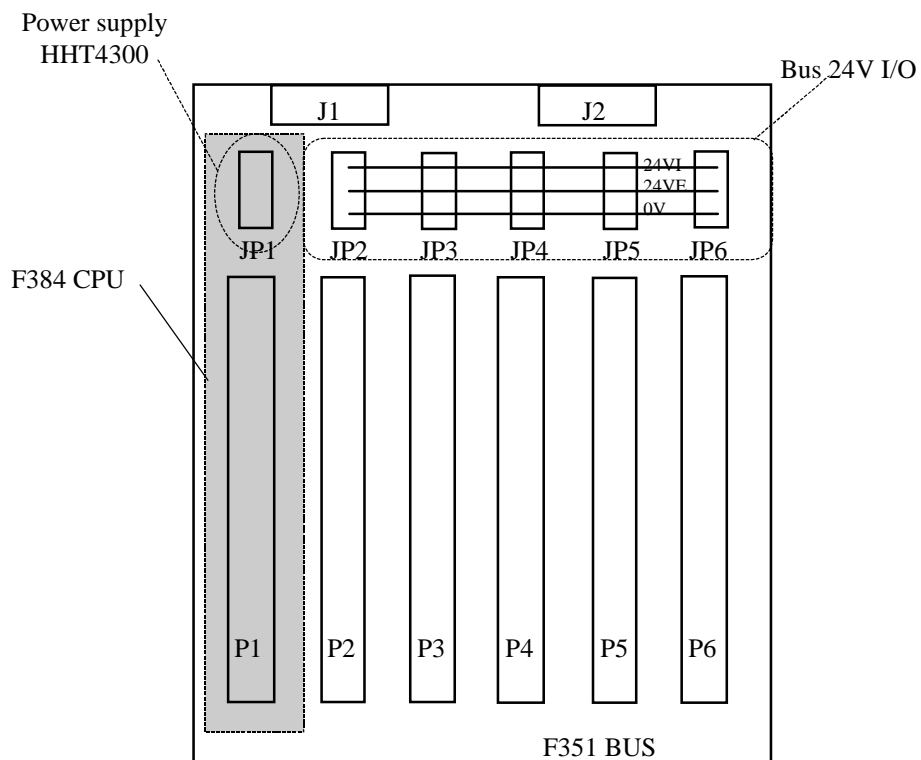

The position JP1-P1 is typical for the CPU card, all the remaining positions are available for the control device configuration.

The BUS module needs no preset.

5. F384-CPU Microprocessor card

This is the system calculation centre and it is fitted with a MCU Motorola 68332 card (20MHz clock). Data and program RAM resides on flash eeprom (1MB).

Permanent data is stored in a buffer battery.

The CPU has 2 ports, an RS485 full/duplex port for the HHT4300 programming terminal or a Laptop (P1 Sub-d 9-way connector located on the front part), and another one for connecting the multifunctional display (internal port).

CPU status Led indicators:

- LOWBATT - Red: illuminated during power reset (when switching on the Control device) and when the reset is given via the push button. If it stays On during the operation (RUN led indicator illuminated) this indicates that the battery is nearly down.
- RUN - Green: the processor is operating correctly when illuminated. This indicator is OFF during the reset or when the Watchdog (indication of Fault) condition intervenes.

Reset push button

The Reset push button is placed in the lower part, This control has direct influence on the 68332 and is used (in case of system shutdown) to re-start the program with no need to cut off power to the control device.

The Reset control is not an alarm reset and it must not be used to this end.

Internal battery for data backup

Lithium battery with surveying circuit of the charge status and Supercap (high capacity capacitor) used to store data during the replacement. The battery is housed in a container which facilitates the replacement.

To replace the battery, refer to Appendix A - Maintenance

Average battery life

<i>Extinction</i>	<i>Operating condition</i>	<i>Duration (years)</i>
Daily	6 working days	3
Weekly	5 working days	4
Weekly	6 working days	5,4

P1 - 9-way, Sub-d socket connector

RS485 serial communication port for the connection to the HHT4300 programming unit or to a PC

Pin	Signal	Description
1/6	OVH	Earth
2/7	+VH	HHT4300 unit power supply
3	N.C.	Pin bias
4	RXD+	Data reception +
5	TXD+	Data transmission +
8	RXD-	Data reception -
9	TXD-	Data transmission -

For maximum length of connection cable see paragraph 2.4.3

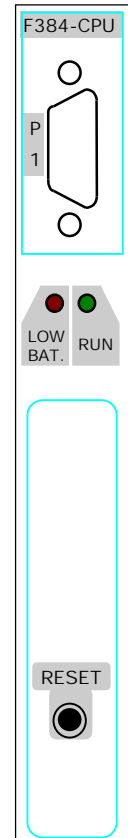

Card layout: Standard setting of jumpers.

JP4-5-8-9: (Off)

JP3: 3-4, 6-7

JP6: On

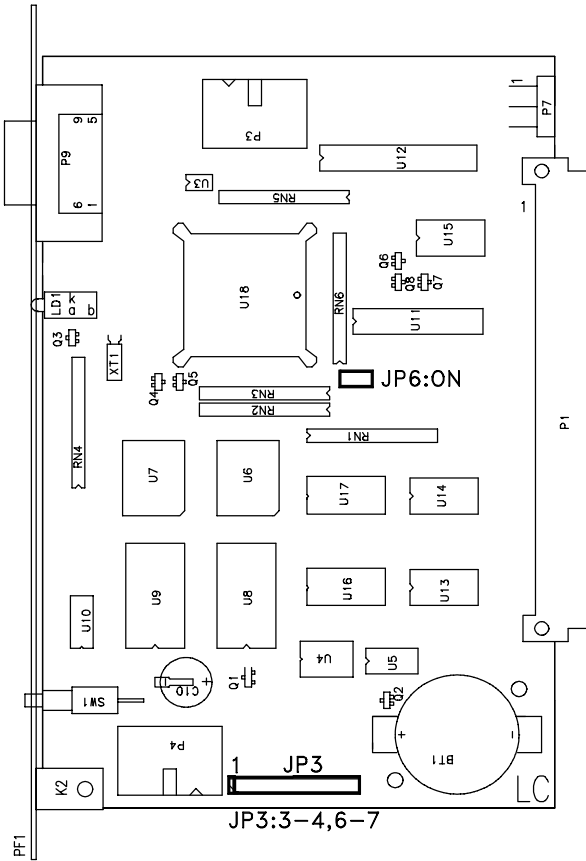

6. F353-ADC Analogue Card

This card includes 3 analogue inputs for acquiring signals from connectors P2 - P3 - P4 and the internal arrangement for housing the SEV module (optional extra) with output on the P2 for the electrode pressure adjustment (proportional solenoid valve).

6.1 P3 e P4 . Description of the analogue inputs

P3 - TV - 9-way, Sub-d plug connector

Input for acquiring analogue signals (optional extra); Generally it is not used and is reserved for special applications
Sensitivity: 36V max.

Pin	Signal	Description
7	TV+	Positive signal
8	TV -	Negative signal
9	TVsch	Cable screening

P4 - TA - 9-way, Sub-d plug connector

Input for acquiring analogue signals.
It is used for connecting the current sensor.
The acquisition of this signal (when welding current is constant), permits the real-time check on the current trend during the welding pulse.
Input is so arranged to accept a 150mV/kA $\pm 3\%$ Rowgowsky type sensor with 20-25ohm internal resistance.
Sensitivity: adjustable.
Facility to connect up to a maximum of 6 sensors in series.
For correct use, see setting parameters indicated in the programming manual.
For the connections, refer to relevant application diagrams.

Pin	Signal	Description
1	TAsch	Cable screening
4	TA+	Positive signal
5	TA-	Negative signal

NOTE: The control device can be operated even if the F353-ADC card is not installed, but, in this case, only the «normal» welding mode is allowed.
This type of operation however is detrimental to the processing quality and it has now been superseded.

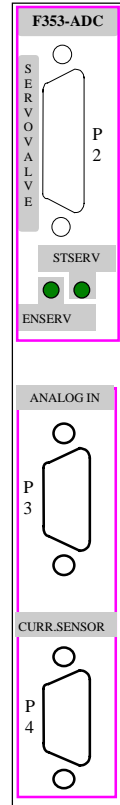

6.2 P2 . Description of the signals for the Solenoid valve and the TFE

The two green LED indicators are for the proportional solenoid valve and their function is the following:

ENSERV : = illuminated when the relevant output on P2 is active

STSERV : = illuminated when the signal is present on the input.

15-way, Sub-d socket connector

Pin	Signal	Description
1	TFEsch	Screening of analogue voltage input
2	TFE-	Analogue voltage input
3	VServ-	0V voltage output for solenoid valve
4	IServ+	4-20mA current output for solenoid valve
5	Res2	Reserved
6	STSERV	Servo valve status input
7	0V	Solenoid valve power supply
8	24SV	Solenoid valve power supply
9	TFE+	Analogue voltage input
10	VServ+	0-10V voltage output for solenoid valve
11	Schild	Screening for ISERV or VSERV signal
12	IServ-	0V current output for solenoid valve
14	Res1	Reserved
15	ENSERV	Solenoid valve Enable Output

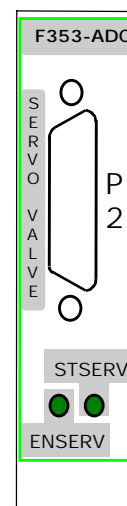

P2 . Functional description of signals

Pin	Signal	Function
1,2,9	TFE	Analogue voltage acquisition channel. This input can be used for receiving the indication of the electrodes force through a dedicated transducer.
4,12	ISERV	Current output. Operating range from 4 to 20 mA. Signal for piloting a current type solenoid valve. The valve adjusts pressure on the electrodes as a function of this signal, 20mA correspond to 100% of the pressure value which has been calibrated on the proportional valve. Load resistor: 470 Ω (range: from 200 to 600 Ω)
3,10	VSERV	Voltage output. Operating range from 0 to 10V. Signal for piloting a voltage type solenoid valve. The valve adjusts pressure on the electrodes as a function of this signal, 10V correspond to 100% of the pressure value calibrated on the proportional valve. The output is protected against overcurrent and short circuit. In case of tripping of the protective device, outgoing voltage falls to 0 Volt. Typical resistive load: 10K Ω
6	STSERV	Input. Electrodes pressure OK. The logic condition 0V or 24V can be defined in the Setup stage. Before welding, the control device waits for this signal produced by the solenoid valve: if the logic condition is TRUE (24V), the control device gives the welding pulse, if it is FALSE (0V), the welding sequence stays idle with the electrodes closed.
7	0V	0V solenoid valve power supply.
8	24SV	Solenoid valve power supply Power supply to the solenoid valve is monitored with a voltage value: if it falls below 22.5V (5% of 24V), the ENSERV enable signal of the solenoid valve is not activated.

P2 . Functional description of signals

Pin	Signal	Function
11	Shield	ISERV o VSERV servovalve signal screening
15	ENSERV	Output. Active at 24V. Proportional solenoid valve enable. Before commencing the adjustment operation, the solenoid valve waits for this signal from the control device. ENSERV output is deactivated when: <ul style="list-style-type: none"> • Solenoid valve power supply falls below 5% • I/O sequence is during cold processing cycles • CPU is in the reset status.

Card layout: standard setting of jumpers

J2: 1-2
Jp5: Off

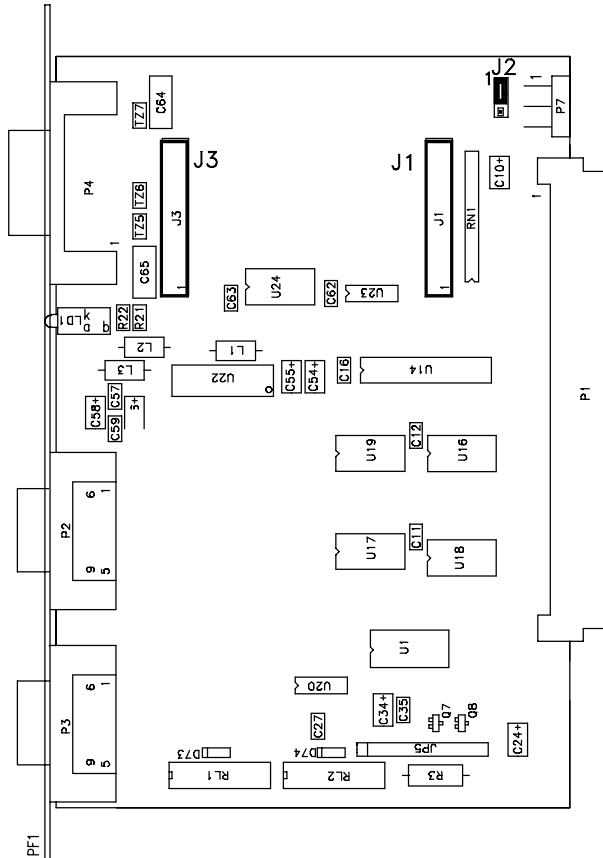

7. F364-SEV and F385-SEV: Proportional Servovalve Modules

The F364-SEV or F385-SEV module (housed internally on the F353-ADC card) is an analogue driver with two outputs: a voltage output and a current output used to pilot a proportional servovalve.

The proportional servovalve is able to adjust the pressure inside a pneumatic circuit automatically on the basis of an analogue voltage or current signal from the welding control device. The welding gun pneumatic cylinder converts the pressure in the pneumatic circuit into an electrode closing force.

This function is of great importance for process quality. The electrode closing force, the time during which current flows and the welding current are the three main parameters that determine welding quality.

With the proportional servovalve the electrode closing force can be kept under control.

For use and programming of the proportional output, please see the Control Device Programming Manual.

7.1 Servovalve Adjust:

The pressure servovalve must be adjusted for two operating conditions: the first is the line pressure under machine stopped conditions; the latter refers to the working pressure of the cylinder.

These adjustments are dependent on the settings entered in the Setup menu and in the welding program (see Programming Manual).

On the basis of these settings, the Weld334m pilots the analogue voltage output over a range from 0 to 10V or the analogue current output over a range from 4 to 20 mA.

The control can enable/disable the servovalve by means of the signal ENSERV.

After a welding sequence has been selected, the control pilots the analogue output on the basis of the parameters P1 and P2 set in the welding programme. The guns close and the electrodes reach the requested closing force.

Before carrying out the welding operation, the control device waits for the STSERV signal from the servovalve, which confirms that the rated pressure has been attained. It then imparts the welding pulse.

If the STSERV signal fails, the cycle stops under pressure and welding is not done.

If the servovalve is used with the current analogue output 4 – 20 mA, the continuity control can be enabled on the output circuit, so if connection with the servovalve is interrupted the welding cycle is also interrupted. (present from F364-D version onwards)

If the servovalve is not used, the «**PRESSURE-OK Input mode**» parameter in the Setup menu is set to zero.

For the connections, see application diagrams

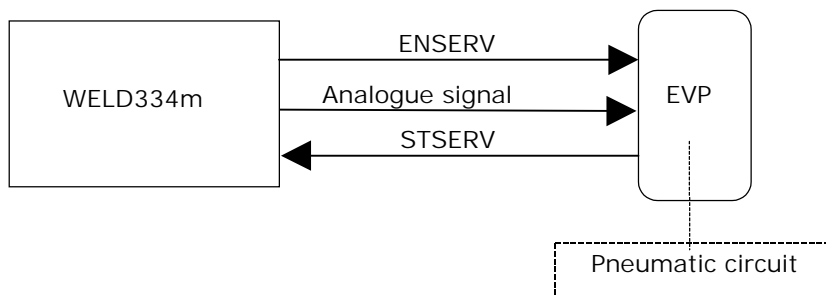

7.1.1 Voltage outlet characteristics

Range: 0-10V

Single-ended type, with VSERV- pin connected with the 0V of the +24SV

Minimum load: 2k ohm

Typical load: 10k ohm

Converter resolution: 12 bit

Converter accuracy: ± 3 lsb

Protection against permanent short-circuits

Protection of VSERV+ outlet pin against accidental contacts up to 36V DC

7.1.2 Current outlet characteristics

Range: 4-20mA

Single-ended type, with ISERV- pin connected with the 0V of the +24SV

Maximum load: 600 ohm

Minimum load: 200 ohm

Converter resolution: 12 bit

Converter accuracy: ± 3 lsb

Protection against permanent short-circuits

Protection of ISERV+ outlet pin against accidental contacts up to 36V DC

Test on open current loop

7.2 Connection of the F364 / F385-SEV module on the F353-ADC card

The F364 / F385-SEV module houses the whole electronic circuit for the servovalve management. Its mounting on the F353-ADC card poses no problems, this can be easily made through the two connectors J1 and J3.

The J3 connector is polarised (contacts 9 and 10 are not present) to prevent incorrect mounting of the module.

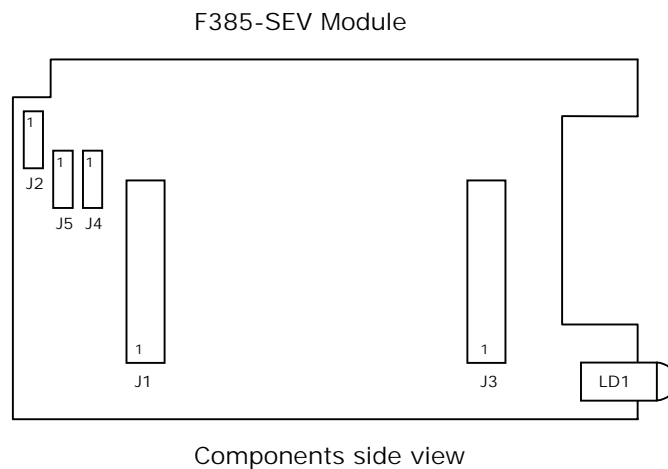

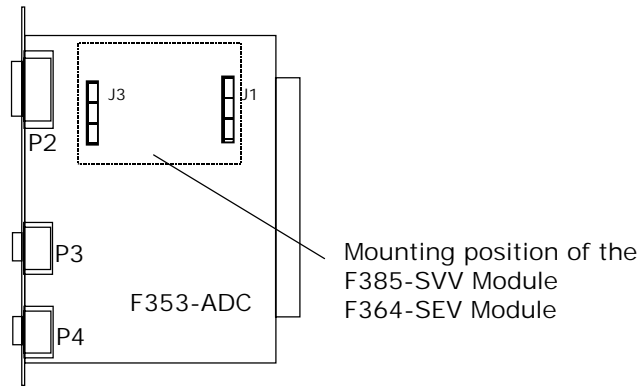

Fixing of the module is ensured by the tight fit of the two connectors J1-J3

Make sure that the module is properly fitted into the card.

(For the SEV pin-out refer to the chapter "P2. Description of the signals for the Solenoid valve and the TFE").

7.2.1 Jumper function on connector J4

For further information consult the chapter "Use of 24V I/O"

Pins connected	Description
1-2	Power supply to SEV from internal 24Vdc
2-3	Power supply to SEV indirect from internal 24Vdc or from external 24Vdc

7.2.2 Jumper function on connector J5

Pins connected	Description
1-2 (Default)	24Vdc limiter SEV power supply OFF. Position required when stabilized 24Vdc is available (e.g.: with PSM type F370)
2-3 (Only for F364, for compatibility with old module F368)	24Vdc limiter SEV power supply ON. Position required when non-stabilized 24Vdc is available (e.g.: with PSM type F367)

8. F392-I/OB Basic I/O Card

Basic card of the I/O connections towards the system, characterized by a two-position selector and linear connectors P20, P44, P22 with corresponding leds.

8.1 Weld YES/NO selector

Enables/disables the welding current.

Weld Yes/No must also be enabled in the Setup*.

Weld YES: Turned to  welding current is enabled.

Weld NO: Turned to  welding current is disabled.

*See programming manual

8.2 P20 Power supply

4-pin, p.3.5 disconnectable terminal linear connector

24V power supply output for devices external to the control.

The 24V source depends on the type of connection used on the PS connector of the power supply unit (see power supply technical section).

The 24V is protected against short-circuits by an auto-reset fuse located on the power supply unit.

The green 24V present led is located to the side of pin 1.

Pin	Signal	Description
1	24V	Output for I/O power supply
2	24V	Output for I/O power supply
3	0V	Ground for I/O power supply
4	0V	Ground for I/O power supply

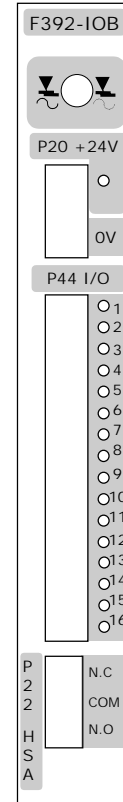

8.3 P22 HSA - Circuit breaker release

3-pin, p.5.08mm disconnectable terminal linear connector

Relay contacts for tripping of the release coil of the main circuit breaker of the machine.

It is activated by the control in the case of a serious fault in the power section of the machine (e.g. SCR conducting except during welding) and by activation of the Watch-dog signal of the Processor.

Characteristics of the contacts:

Max. voltage	48Vdc
Rated current	6A
Max. instantaneous current	30A

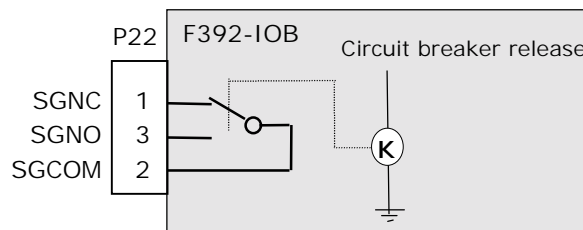

For the connection, refer to the application diagrams.

8.4 P44 . Input-Output

24Vdc discrete digital Inputs and Outputs protected against overvoltages.

All the I/Os are complete with respective signal present led.

16-pin, p.3.5mm disconnectable terminal linear connector

Pin	Signal	Description	Towards	Type
1	FIRING+	Firing trans. power supply	Output	
2	FIRING-	SCR fire command	Output	
3	TSCR	SCR temperature	Input	type 2
4	EMERG	Emergency	Input	type 2
5	STARTA	Start channel A	Input	type 2
6	STARTB	Start channel B	Input	type 2
7	CONDUZ+	SCR conduction + pole	Input	type 2
8	CONDUZ-	SCR conduction - pole		
9	STATUS	Weld Yes/No	Output	type 0,5
10,11	EVSA	Control of welding channel A solenoid valve	Output	Relay contact
12,13	EVSB	Control of welding channel B solenoid valve	Output	Relay contact
14	IMAGEBE	Reserved	Input	type 2
15	SALDASI	Weld Yes	Input	type 2
16	SOLOPR	Pressure only	Input	type 2

Electrical data:

Type 2 solid-state inputs (IEC EN61131-2 type 2 DC input)

Rated voltage	24Vdc
Max. continuous voltage	30Vdc
Max. non-continuous voltage	36Vdc (max duty cycle 80%)
Max. voltage for state 0	5V
Min. voltage for state 1	11V
Min. current for state 1	6mA @11V
Max. current max for state 1	30mA @30V

0.5 type solid-state outputs (IEC EN61131-2 0.5 rated current DC output)

Rated voltage	24Vdc
Max. continuous voltage ¹	30Vdc
Max. non-continuous voltage ²	36Vdc (duty cycle 12%)
Continuous output current state 1	0,6A
Max. loss current state 0	2mA
Protection tripping current	>0.7A

¹ with F370 24Vdc stabilized power supply unit

² with F367 power supply unit or 24Vdc non-stabilized external power supply

Outputs with relay contact

Max. voltage	30Vdc
Rated current	2A
Max. instantaneous current	30A
Min. switchable current	10mA
Mechanical life	2x10 ⁶

P44 - Functional description of the signals

Pin	Signal	Function
1	+24TRASF.	24V power supply of the primary of the SCR firing transformer (to be used only for this purpose).
2	COMIMP	SCR Fire impulse command (See application diagrams).
3	TSCR	SCR overheating Active OFF. The sensor must be of the type with N.C: contact. In the case of overheating, the TSCR signal is interrupted and the control activates the matching alarm and blocks the machine cycle.
4	EMERG	EMERGENCY Active OFF. Is connected to a 24V N.C. contact that is opened (by the robot or in Manual mode) in an emergency. The control inhibits the sequence and does not permit Start until the 24V is re-activated this Input. See EMERGENCY diagrams in Appendix B.
5	STARTA	Start channel A. Active at +24V. The control activates the EVSA output (called gun A) and performs the welding program required. If Start is interrupted before the pressure cycles have been performed, the EVSA output is de-activated and the electrodes re-open. After the pressure cycles, Start remains latched until the end of the frequency cycles
6	STARTB	As for STARTA but for channel B.
7/8	CONDUZ ±	SCR conduction detection signal input. Is tapped from the secondary of a transformer connected in parallel to the SCR group in order to detect conducting of this. See application diagrams
9	STATUS	Enable welding current. Active at 24V. Indicates the Weld Yes condition; when Weld Yes is enabled, this output goes high (see also SaldaSi).
10/11	EVSA +/-	Output that drives the welding channel A solenoid valve. Relay contact closed when the output is active. Activated by STARTA, it is protected by a 2-relay interlock that prevents a concurrent call to channel B. If the STARTA signal drops out before the pressure cycles have been completed, the call is not recognized and the electrodes re-open. After the pressure cycles, START remains automatically latched until the end of the Hold cycles. (See cycle time diagrams in the programming manual).

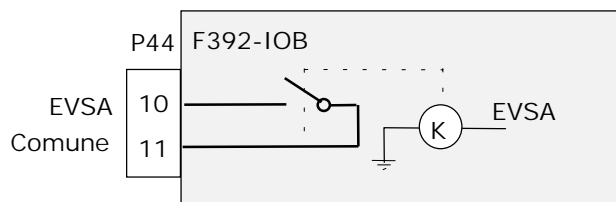

12/13	EVSB +/-	Output that drives the welding channel B solenoid valve. Relay contact closed when the output is active. As for EVSA but for channel B
14	IMAGEBE	24Vdc input. Dedicated signal

Pin	Signal	Function
15	SALDASI	<p>Weld Yes. Active at +24V. Enables the welding current; Weld Yes must also be active in the Setup* and the selector on the front edge. The control activates the STATUS output (+24V) when Weld Yes is enabled. * See programming manual.</p>
16	SOLOPR	<p>Pressure only. Active OFF. Used for gun adjustment. Normally at 24V, if opened during the welding, the following condition occurs:</p> <ul style="list-style-type: none"> - the sequence is interrupted with the electrodes closed in pressure - the control waits for the 24V on this Input - the RICHSALD output is low <p>If START is released, the call is interrupted and the gun re-opens. If SOLOPR goes high, the sequence is restarted, the control sends the RICHSALD output high and proceeds according to the status of SALDASI and CONSALD.</p>

Card layout: setting of the jumpers

- JP1: Off
- JP3: Off
- J1: 2-3
- J2: 1-2

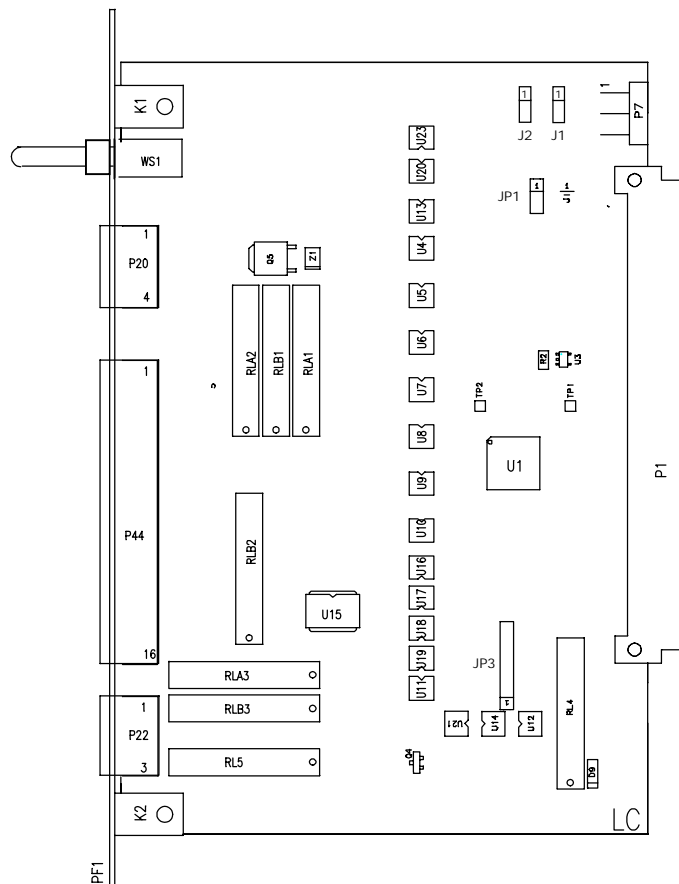

9. F393-IOE I/O Expansion card

24V discrete I/O signal expansion card.

Characterized by two terminal type connectors, P43 and P42, for field connections that support 18 inputs and 16 outputs, 4 of which are dedicated to control of the additional opening solenoid valves and protected, via relay contact, against accidental calls.

All the outputs are protected against short-circuits.

9.1 P42 . Description of the output signals

16-pin, p. 3.5 disconnectable terminal linear connector

Pin	Signal	Description	Typology	Type
1	WALLSTA	Pre-alarm stepper A	Electrode wear function	type 0.5
2	WALLSTB	Pre-alarm stepper B	Electrode wear function	type 0.5
3	RICHRVA	Dressing request A	Electrode wear function	type 0.5
4	RICHRVB	Dressing request B	Electrode wear function	type 0.5
5	RICHELA	Electrode change request A	Electrode wear function	type 0.5
6	RICHELA	Electrode change request B	Electrode wear function	type 0.5
7	ALARM1	Diagnostics alarm	Welding diagnostics	type 0.5
8	ALARM2	Hardware alarm	Machine fault	type 0.5
9	RICHSA	Welding request	Status	type 0.5
10	FINASA	End welding	Status	type 0.5
11	FINESEQ	End sequence	Status	type 0.5
12	READY	Control ready	Status	type 0.5
13	EVASA1	Additional opening channel A (opening)	Solenoid valve command	Relay contact
14	EVASA2	Additional opening channel A (closing)	Solenoid valve command	Relay contact
15	EVASB1	Additional opening channel B (opening)	Solenoid valve command	Relay contact
16	EVASB2	Additional opening channel B (closing)	Solenoid valve command	Relay contact

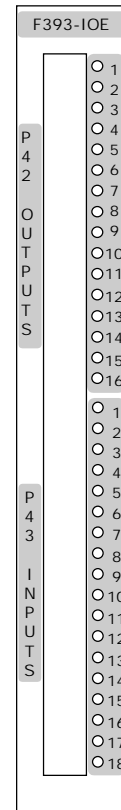

Electrical data:

Type 0.5 solid state outputs (IEC EN61131-2 0.5 rated current DC output)

Rated voltage	24Vdc
Max. continuous voltage	30Vdc
Max. non-continuous voltage	36Vdc (duty cycle 12%)
Continuous output current state 1	0.6A
Max. loss current state 0	2mA
Protection tripping current	>0.7A

¹ with F370 24Vdc stabilized power supply unit

² with F367 power supply unit or 24Vdc non-stabilized external power supply

Outputs with relay contact

Max. voltage	30Vdc
Rated current	2A
Max. instantaneous current	30A
Min. switchable current	10mA
Mechanical life	2x10 ⁶

P42 . Functional description of the signals

Pin	Signal	Function
1	WALLSTA	Pre-alarm stepper A. Active at +24V. This output is activated concurrently with welding in which the value set for the electrode wear pre-alarm of the last Stepper used on welding channel A is reached. It is switched off at the next welding operation. It is non-blocking and warns the operator that the counter is close to the Stop threshold of the stepper. Consult the programming manual for conditions of use. The message is saved in the alarm log.
2	WALLSTB	Pre-alarm stepper B. Active at +24V. As for WALLSTA but for channel B.
3	RICHRAVA	Dressing request channel A. Active at +24V. The number of welding operations programmed for electrode dressing of the last Stepper used on welding channel A has been reached. Steady light: blocking condition that can be reset only by clearing the counter of the matching stepper via the RAVOKA (P43-7) input or via software reset in the Stepper menu. Flashing light: the machine is not blocked and input RAVEXTA is activated.

P42 . Functional description of the output signals

Pin	Signal	Function
4	RICHRAVB	Dressing request channel B. Active at +24V As for RICHRAVA but for channel B. Counter clear input RAVOKB (P43-8). Flashing light: the machine is not blocked and the RAVEXTB input is activated.
5	RICHEL A	Electrode change request channel A. Active at +24V. The number of welding operations programmed for electrode replacement of the last Stepper used on welding channel A has been reached. Steady light: machine blocking condition, can be reset only by clearing the counter of the matching stepper via the CHGEOKA (P43-9) input or via software reset in the Stepper menu
6	RICHEL B	Electrode change request channel B. Active at +24V. As for RICHEL A but for channel B. Counter reset input CHGEOKB (P43-10)
7	ALARM1	Indication. Active at +24V. Does not block the processing cycle. Diagnostic class alarm (from E001 to E050). Is normally reset automatically but can be set to blocking condition in the Setup menu. See Alarms and Setup chapters of the programming section
8	ALARM2	Machine alarm. Active at +24V. Blocks the cycle. Refers to faults, programming errors, connection errors of both the control and machine. Can be cleared through reset from HHT or from the dedicated inputs RESHWFK and RESHWRP. Remains active until the cause has been eliminated

P42 . Functional description of the output signals

Pin	Signal	Function
9	RICHSALD	<p>Welding request. Active at +24V.</p> <p>At the end of the pressure cycles, the control, ready to perform the welding impulse, activates the welding requests and waits for consent (CONSALD P43-18).</p>
10	FINESALD	<p>End Welding. Active at +24V.</p> <p>At the end of the welding cycles, the control activates this message and continues the sequence until opening of the electrodes according to the cycle programmed.</p>
11	FINESEQ	<p>End of Sequence. Active at +24V.</p> <p>At the end of the frequency cycles (opening of electrodes), the control activates this output and terminates the sequence.</p> <p>It is cleared at the end of the frequency cycles with the START=0 signal.</p> <p>If Repeat is enabled, End of Sequence is not performed and the control continues, restarting from the pressure cycles (see programming manual, cycle time diagrams).</p>
12	READY	<p>Control ready message output. Active at +24V.</p> <p>This output is activated when the control is ready, i.e. when all the conditions to perform a welding cycle are present.</p> <p>When ALARM1 or ALARM2 occur, the output is low.</p>
13	EVASA1	<p>Control of additional opening channel A solenoid valve. Mono-stable output, active at +24V.</p> <p>Invokes opening of gun A (solenoid 1 of solenoid valve A).</p> <p>Activated by the CEVASA command.</p> <p>It is protected by a two-relay interlock that prevents a concurrent call to channel B.</p> <p>If the Start signal drops out before the pressure cycles have been completed, the call is not recognized and the electrodes re-open.</p> <p>After the pressure cycles, the start remains automatically latched until the end of the Hold cycles.</p>
14	EVASA2	<p>Control of additional opening channel A solenoid valve. Mono-stable output, active at +24V.</p> <p>Invokes closing of gun A (solenoid 2 of solenoid valve A).</p> <p>Activated by the CEVASA command.</p> <p>It is protected by a two-relay interlock that prevents a simultaneous call to channel B.</p> <p>If the Start signal drops out before the pressure cycles have been completed, the call is not recognized and the electrodes re-open.</p> <p>After the pressure cycles, the Start remains automatically latched until the end of the Hold cycles.</p>
15	EVASB1	<p>Control of additional opening channel B solenoid valve. Mono-stable output, active at +24V.</p> <p>Invokes opening of gun B (solenoid 1 of solenoid valve B).</p> <p>Activated by the CEVASB command.</p> <p>As for EVASA1 but for the channel B.</p>
16	EVASB2	<p>Control of additional opening channel B solenoid valve. Mono-stable output, active at +24V.</p> <p>Invokes closing of gun B (solenoid 2 of solenoid valve B).</p> <p>Activated by the CEVASB command.</p> <p>As for EVASA2 but for channel B.</p>

9.2 P43 . Description of the input signals

18-pin, 3.5p. linear connector for disconnectable terminals

Pin	Signal	Description	Type
1	RESHWFK	Reset hardware alarm end of sequence	type 2
2	RESHWRP	Reset hardware alarm with repeat	type 2
3	CEVASA	Additional opening channel A command	type 2
4	CEVASB	Additional opening channel B command	type 2
5	RAVEXTA	Selection of dressing program channel A	type 2
6	RAVEXTB	Selection of dressing program channel B	type 2
7	RAVOKA	Confirmation dressing performed channel A	type 2
8	RAVOKB	Confirmation dressing performed channel B	type 2
9	CHGEOKA	Confirmation electrode change performed channel A	type 2
10	CHGEOKB	Confirmation electrode change performed channel B	type 2
11	CODE0	Program code bit 0	type 2
12	CODE1	Program code bit 1	type 2
13	CODE2	Program code bit 2	type 2
14	CODE3	Program code bit 3	type 2
15	CODE4	Program code bit 4	type 2
16	CODE5	Program code bit 5	type 2
17	CODEP	Program code parity bit	type 2
18	CONSALD	Welding consent	type 2

Electrical data:

Type 2 solid-state inputs (IEC EN61131-2 type 2 DC input)

Rated voltage	24Vdc
Max. continuous voltage	30Vdc
Max. non-continuous voltage	36Vdc (max duty cycle 80%)
Max. voltage for state 0	5V
Min. voltage for state 1	11V
Min. current for state 1	6mA @11V
Max. current for state 1	30mA @30V

P43 . Functional description of the input signals

Pin	Signal	Function
1	RESHWFK	Reset hardware alarm with End Sequence. Active at +24V. All alarms in course are reset. If the START signal is still present, the END SEQUENCE signal is activated.
2	RESHWRP	Reset hardware alarm with Repeat. Active at +24V. All alarms in course are reset and if the START signal is still present, the sequence is repeated
3	CEVASA	Control of additional opening A solenoid valve. Active at +24V. Start of electrode pre-approach, is enabled and disabled with a rising edge 0-24V, (impulse type). Signal read time < 100ms. If it is not used, this input must be connected directly to the +24V.
4	CEVASB	Control of additional opening B solenoid valve. Active at +24V. As for CEVASA but for channel B.
5	RAVEXTA	Selection of dressing program channel A Active at +24V. The next sequence will be performed with the predefined welding program for dressing. If RICHRAVA=0, the output is made to flash at an interval of 0.5s. The signal must be active for at least 100ms.
6	RAVEXTB	Selection of dressing program channel B Active at +24V. The next sequence will be performed with the predefined welding program for dressing. If RICHRAVB=0, the output is made to flash at an interval of 0.5s. The signal must be active for at least 100ms.
7	RAVOKA	Confirmation of dressing performed on channel A. Active at +24V. Inhibits the alarm warnings, resets the welding spot counter and increases the dressing counter in the electrode wear program by 1. This operation can also be performed from the programming keypad using the stepper menu (see programming manual). The signal must be active at least for 100ms
8	RAVOKB	Confirmation of dressing performed on channel B. Active at +24V. As for RAVOKA but for the channel B.
9	CHGEOKA	Confirmation of electrodes changed on channel A. Active at +24V. This input must be activated after electrode dressing (following the Electrode Change Request message). The following operations are performed for the Steppers active on welding channel A at the time of the command: Reset dressing counter; Reset weld counter. The signal must be active for at least 100ms.
10	CHGEOKB	Confirmation of electrodes changed on channel B. Active at +24V. As for CHGEOKA but for channel B

P43 . Functional description of the input signals

Pin	Signal	Function
11	CODE0	Active at +24V.
12	CODE1	Inputs dedicated to selection (in binary code) of the welding program to be run at Start. When Start is active, the control runs the program corresponding to the binary code read (see code table on page 38). Up to 64 welding programs can be used. NB: To select program 64, all the inputs of the program code must be at logical 0V.
13	CODE2	
14	CODE3	
15	CODE4	
16	CODE5	
17	CODEP	Parity code. Active at +24V. Used only on robotized lines. Is used for logical checking of the CODE0...5 inputs and depends on the setting in the Setup menu. (see code table on page 38). Warning! If it is not used, it must be disabled (see Setup programming manual).
18	CONSALD	Welding consent. Input active a +24V. The welding consent is the weld enable signal; it indicates that the welding machine is ready; the welding control waits for this signal after it has sent the RICHSALD signal. The control waits until the consent signal is received

Card layout: standard configuration of the jumpers

J1: 2-3
JP1: Off

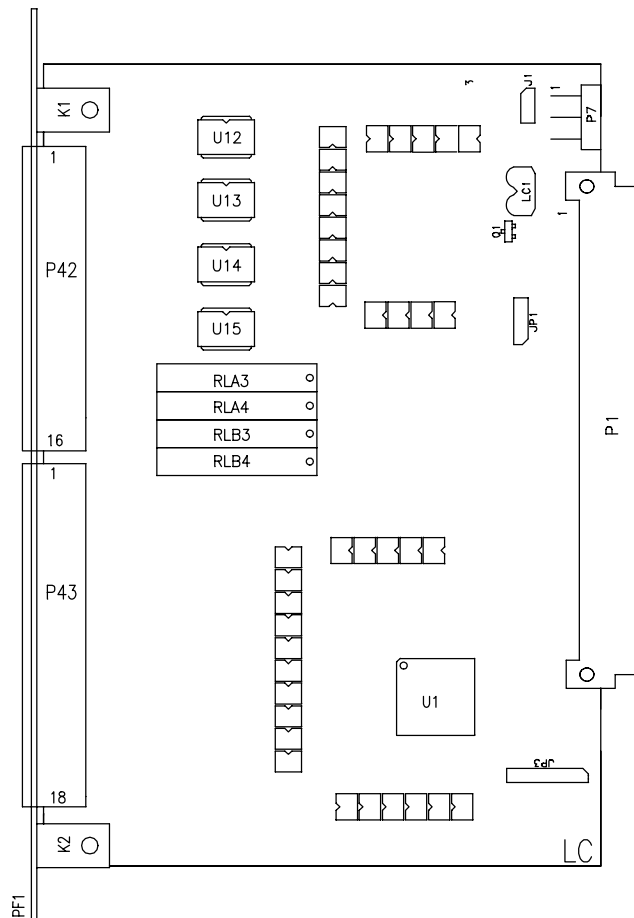

10. F359-MCP Memory Card and Printer

The F359-MCP card supports a PCMCIA type memory card (Ram Card) and the parallel port for connection to a printer.

MEMORY CARD

Standard connector for the PCMCIA card.

The memory card allows saving the configuration as well as all the welding programs of a control device or memorising the operating software.

Thus, you are given the facility to perform two maintenance operations quickly and in an easy way.

The first operation concerns the immediate replacement of a welding control device.

Thanks to the Ram Card all data is quickly transferred from one device to another with no need to configure and hand copy all the programs to the new control device.

The second operation is the operating software update through by a simple loading operation. In addition, the operating system can be transferred from one control device to another.

For the correct use of the Ram Card, please consult the Programming Manual, chapter MEMORY CARD.

P5 - PRINTER

25-way Sub-d socket connector

The parallel port allows the connection to a (parallel) printer for printing data concerning the programs, steppers, reports, etc...

For this function, please consult the W334m Programming Manual.

To connect the printer, a standard cable for printers is sufficient (Centronics type – 25-way parallel cable)

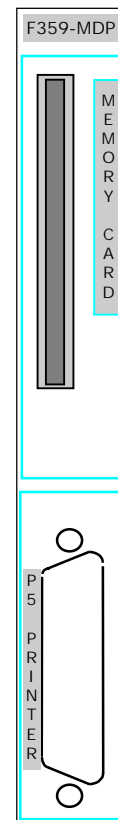

WARNING! This port is not compatible with serial printers

No setting jumpers are on the card.

11. F397-PDP Profibus-DP

11.1 Characteristics

The F397-PDP is a communication card complying with the Profibus DP DIN19245 part 3 standard (EN 50170) for communication of welding I/O information.

The SUB-D P14 connector permits connection with the Profibus network. An 8-way selector for the Profibus network-DP address is provided on the front edge.

The quantity and type of data exchanged depend on the communication *Profile* defined for the specific application where "Profile" is a descriptive document of the data exchanged. The F-PDP01 type Profile is associated to the F397-PDP card.

11.2 Profibus-DP

11.2.1 P14 - serial port

Sub-d 9-pin female connector

Pin	Signal	Function
5	DGND	Signal ground
9	NC	Not connected
4	NC	Not connected
8	RXD/TXD-N	Data N reception/transmission
3	RXD/TXD-P	Data P reception/transmission
7	NC	Not connected
2	NC	Not connected
6	VP	+5V
1	NC	Not connected

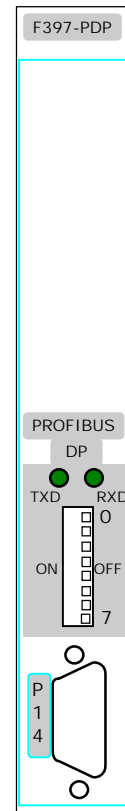

Characteristics: PROFIBUS-DP (DIN 19245 Part3 standard; EN 50170)

Data transfer speed: from 9.6kBits/to 12Mbit/s

Distance: from 1200m to 100m

Recommended components:

Cable : Siemens 6XV1 830-0AH10

Connector : Siemens 6ES5 762-2AA12

For network wiring, refer to the instructions provided in the connector assembly kit.

11.2.2 TXD-RXD led

Two green TXD and RXD leds for serial port monitoring are provided on the front edge.

These indicate communication activity on the Profibus network-DP.

Communication conditions are normal when both leds flash.

11.2.3 ADDRESS selector

The eight-position selector, numbered from 0 to 7, makes it possible to assign an address, in binary code, for recognition of the device in the network by the serial I/O management program.

Consult the related User Manual for use of this.

Note. After setting the address, the control must be restarted using the reset button of the CPU card.

11.3 Card layout

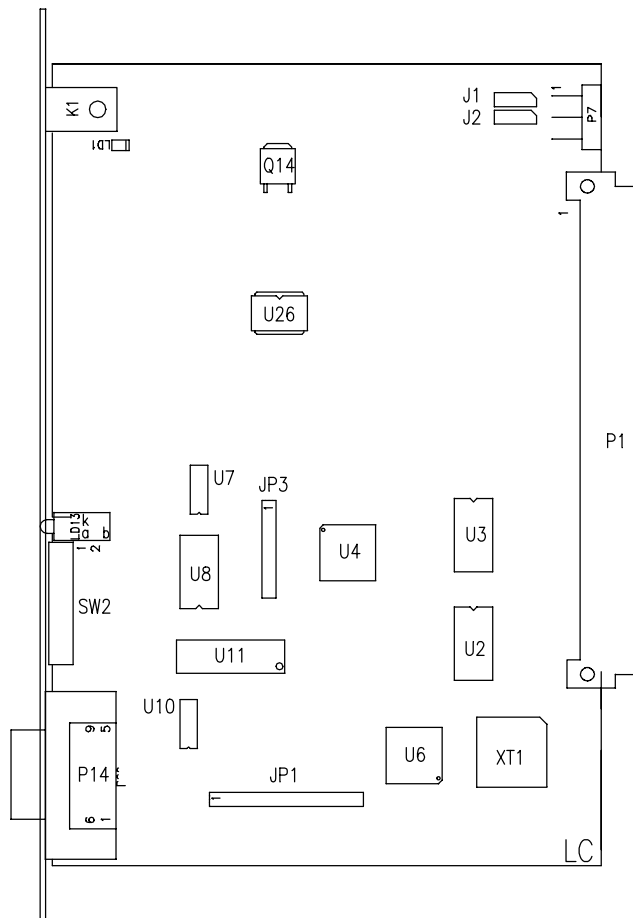

12. F381 Ethernet module with key

Serial communication card for Ethernet 10BaseT IEEE802.3 networks.
 This module enables the welding control to be connected to a serial network of the Ethernet type for communication towards the WMS centralizer.
 It is used as an alternative to the Profibus (F354-PFB) communication card or the Wmsnet (F355-NET) communication card.
 To set the addresses for connection to the network, please consult the programming manual.
 The TCP/IP address of the card is memorized in a "DATA KEY" (DK) device with key located on the front panel.
 The key may be removed to enable the control device to be replaced in case of breakdown without having to set the address on the replacement control device.

LEDs located on the front panel:

LED	Signal	Condition
LAN	Lan activity	ON when data transmission is in progress
LINK	Link status	OFF when there is a line fault

Characteristics:

- Transmission speed: 10Mbyte/s
- Connection: RJ45 8 pin connector

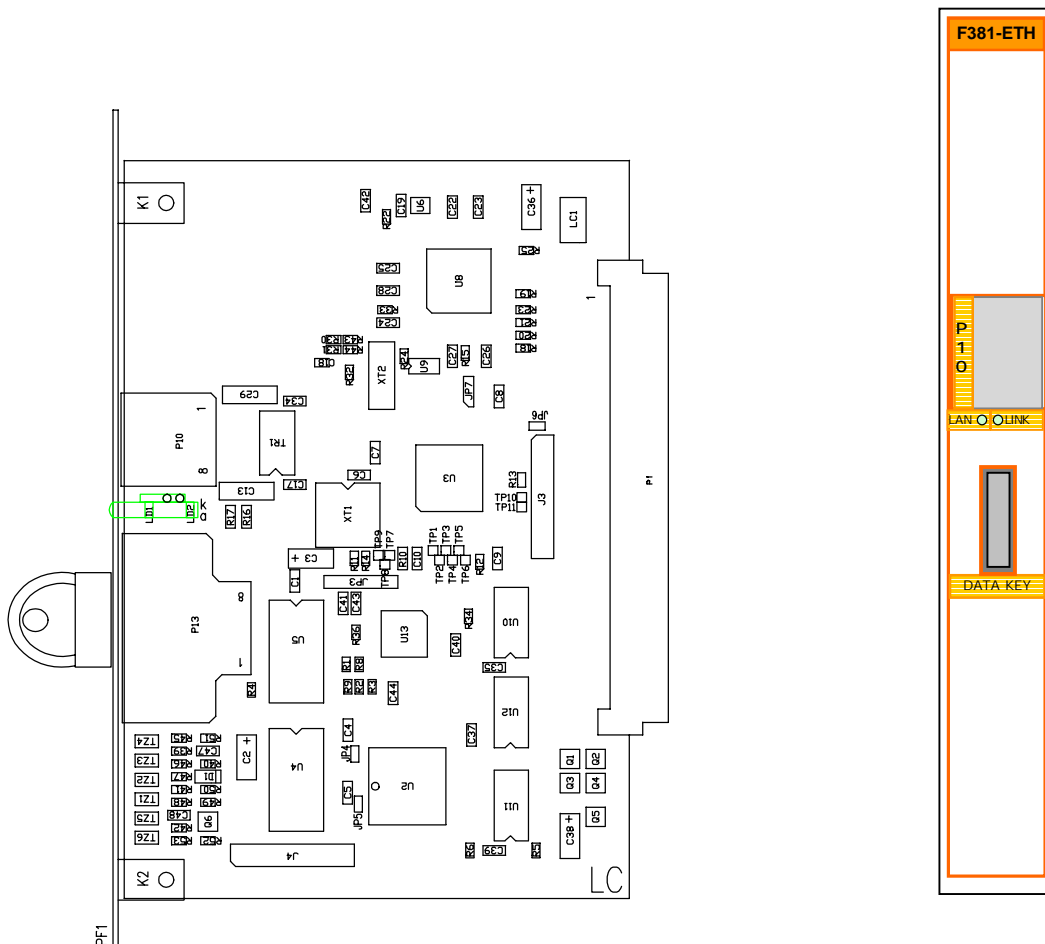

12.1 P10 Ethernet 10Base-T connector

Type RJ45 8-pole female shielded type MDI connection

Pin	Signal	Function
1	TD+	Positive data transmission
2	TD-	Negative data transmission
3	RD+	Positive data reception
6	RD-	Negative data reception
4,5,7,8	not connected	
Shield	Connected to PE	

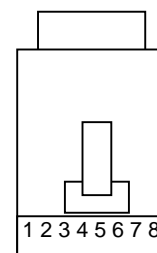

RJ45 connector pinning

12.2 Connection cables

12.2.1 Characteristics

Twisted commercial cable for Ethernet 10 BaseT network.

12.2.2 Type of connection

The signal connection depends on the type of connection of the HUB input port used. It may be a HUB with MDI connection or a HUB with MDI-X connection. Before making the cable check the type of port present on the HUB.

Connection for HUB with MDI-X port

The connection between the two connectors is "Pin to Pin".

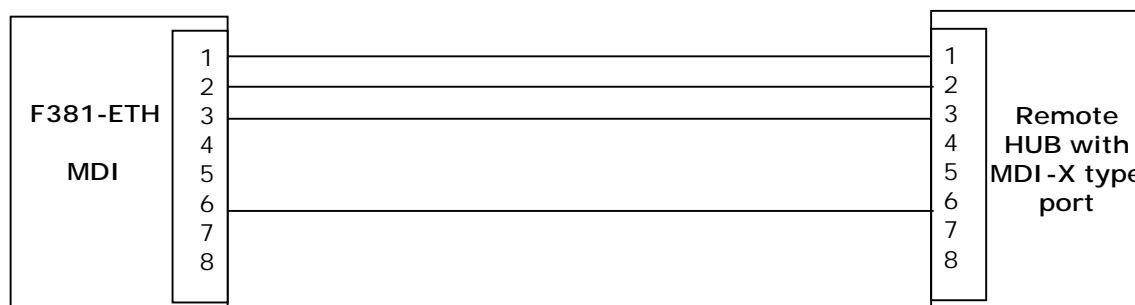

Connection for remote HUB with MDI port.

In the connection with MDI port the signals are "Crossed"

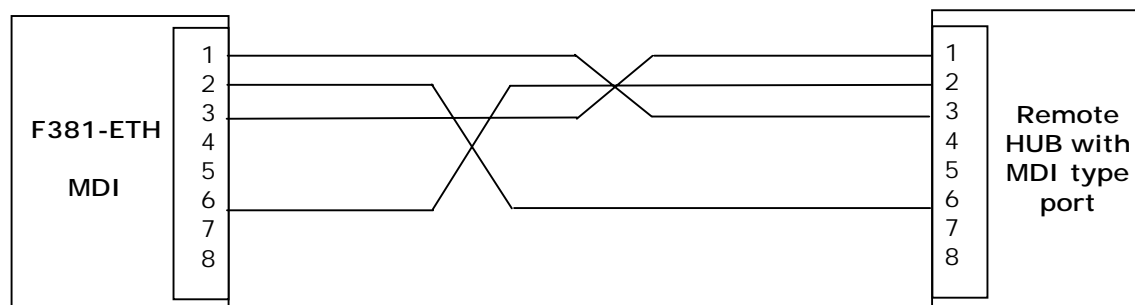

13. Profibus DP Profil F-PDP/01

13.1 General description

A specific data communication *Profile* has been integrated into the firmware of the modular control Weld334m, which is automatically activated in the versions with Interbus-S type serial Fieldbus communication module. This *Profile* was developed for applications in the field of resistance welding. The complete range of functions may be used by inserting modules F366-PDP (Profibus DP) and F378-IOE (auxiliary 24Vdc inputs and outputs) into the control 334m.

The profile is a document describing data exchange with the peripheral in question, defining their interpretation in detail. The reference unit for data exchange is the WORD. Each WORD is made up of 16 bits, numbered from 0 to 15. The data are subdivided into two categories: data from remote devices towards the welding control, identified as *Control Words*; data from the welding control towards the remote devices, identified as *Status Words*.

It should be remembered that these *Words* are specific to this application and are not compatible with applications other than those described in this chapter.

The Profile F-PDP/01 comprises 4 *Control Words* (1-4) and 4 *Status Words* (1-4).

For connections, specifications and materials, please see the documentation **Profibus-DP DIN 19245 Part 3**.

Control Word	USE	Reference module
1	Welding commands towards the control	F366-PDP
2	Selection of welding sequence	F366-PDP
3	Selection of welding spot (Spot Index)	F366-PDP
4	Commands towards the outputs of the F378-IOE I/O module	F366-PDP / F378-IOE

Status Word	USE	Reference module
1	Signals from control	F366-PDP
2	Diagnostic information from welding control	F366-PDP
3	Electrode force and sheet metal thickness values	F366-PDP
4	Status of inputs of F378-IOE I/O module	F366-PDP / F378-IOE

The modules used to have the following functions:

Module F366-PDP has a serial port enabling management of data communication in conformity with the specifications of Profibus (see chapter F366-PDP for the characteristics).

Module F378-IOE is an I/O interface of generic use where the functions of the I/O are defined by the user, through the network Profibus, to obtain specific applications of the working cycle, for example control and command of guns, dressing tools (see chapter F378-IOE for the characteristics).

13.1.1 Control Word

The Control Words are commands relating to the welding sequence sent from the remote interface device to the welding control.

Control Word 1

Control Word 1 defines the commands relating to the fundamental welding functions.

Bit	Description
0	START CYCLE
1	WELD ON
2	FAULT RESET
3	ERROR RESET 0
4	ERROR RESET 1
5	ENABLE SVV
6	Not used
7	Not used
8	RESET STEPPER COUNTER 0
9	RESET STEPPER COUNTER 1
10	RESET COUNTER 0 AFTER TIP DRESS
11	RESET COUNTER 1 AFTER TIP DRESS
12	Not used
13	Not used
14	SELECT ELECTRODE 2
15	SELECT ELECTRODE 4

Control Word 1 - Functional description

Bit	Signal	Function
0	START CYCLE	Bit = 1. Start Command. The number of the welding program is acquired and the related cycle is started.
1	WELD ON	Bit = 1. Welding cycle performed with current. The welding cycle must be performed with current, that is to say with command by the power group.
2	FAULT RESET	Bit = 1. All alarms no longer active will at the reset without further action by the welding control.
3	ERROR RESET 0	Selection of alarm reset modality. See next table
4	ERROR RESET 1	Selection of alarm reset modality. See next table
5	ENABLE SVV	Bit = 1. Authorization to enable servovalve. When this bit is at 1 the control activates the ENSERV signal to the servovalve.
6/7	-	Not used.
8	RESET STEPPER COUNTER 0	Bit = 1. Stepper#0 counters are reset (see electrode selection) after electrode change. A signal is sent to the control that the requested electrode replacement has been completed. The signal must be active for at least 100 ms.
9	RESET STEPPER COUNTER 1	Bit = 1. The Stepper#1 counter is reset (see electrode selection) after electrode change. A signal is sent to the control that the requested electrode replacement has been completed. The signal must be active for at least 100 ms.

Bit	Signal	Function
10	RESET COUNTER 0 AFTER TIP DRESS	<p>Bit = 1. Stepper#0 counter is reset (see electrode selection) after electrode dressing.</p> <p>A signal is sent to the control that the requested dressing operation has been completed.</p> <p>The signal must be active for at least 100 ms.</p>
11	RESET COUNTER 1 AFTER TIP DRESS	<p>Bit = 1. Stepper#1 counter reset (see electrode selection) after electrode dressing.</p> <p>A signal is sent to the control that the requested dressing has been completed.</p> <p>The signal must be active for at least 100 ms.</p>
12/13	-	Not used.
14	SELECT ELECTRODE 2	<p>Select the stepper/electrode pair on which the commands are to act (Control Word 1) and whose status is communicated (Status Word 1).</p> <p>See next table</p>
15	SELECT ELECTRODE 4	<p>Select the stepper/electrode pair on which the commands are to act (Control Word 1) and whose status is communicated (Status Word 1).</p> <p>See next table</p>

Alarm reset mode – Functional description

Bit		Description	Action taken
5	6		
0	0	Alarm Reset	All active error messages are reset
1	0	Reset alarm with Sequence End	All active alarms are reset. If the START signal is still present the Sequence End signal is activated.
0	1	Reset alarm with sequence repeat	All active alarms are reset. If the START signal is still present the sequence is repeated.
1	1	Not used	

Electrode selection-Functional description

“Electrode selection” enables one of the eight different Electrode/Stepper pairs to be selected (a different stepper is assigned to each electrode), which will be associated to the data contained in Control Word 1 and Status Word 1 where Stepper#0 and Stepper#1 appear.

This technique enables up to eight different welding guns to be selected.

Bit		Steppers selected	
14	15	Stepper#0	Stepper#1
0	0	1	2
1	0	3	4
0	1	5	6
1	1	7	8

Control Word 2

Control Word 2 is used to select the welding sequence.

Bit	Description
0	WELD PROGRAM BIT 0
1	WELD PROGRAM BIT 1
2	WELD PROGRAM BIT 2
3	WELD PROGRAM BIT 3
4	WELD PROGRAM BIT 4
5	WELD PROGRAM BIT 5
6	WELD PROGRAM BIT 6
7	WELD PROGRAM BIT 7
8	Not used
9	Not used
10	Not used
11	Not used
12	Not used
13	Not used
14	Not used
15	Not used

Control Word 2 - Functional description

Bit	Signal	Function
0/7	WELD PROGRAM	Select welding programme (1-255) in binary code.
8/15	-	Not used.

Control Word 3

Control Word 3 defines the Spot Index.

The Spot Index is an index (definable from 1 to 65535) used for the selection of a welding spot contained in a database created specifically and managed through the GF Welding WMS centraliser program.

In this database, each Spot Index is associated with a working name (generally the name of the spot to be welded) and the reference to the welding program that must be used.

The necessary part of the database is saved in each welding control, via the WMS centraliser program.

Welding status signals from the Weld334m welding control (diagnostics, program called up, electrode pressure, etc.) are integrated with the Spot Index value and the name of the welding spot.

WARNING

If there is no specific parameterization, where a program code value different from zero (Control Word 1 bit 8-13) and a Spot Index value different from zero (Control Word 3 bit 0-15) appear, the welding control will perform the selected sequence with the program code.

Bit	Description
0	Spot index selection bit 0
1	Spot index selection bit 1
2	Spot index selection bit 2
3	Spot index selection bit 3
4	Spot index selection bit 4
5	Spot index selection bit 5
6	Spot index selection bit 6
7	Spot index selection bit 7
8	Spot index selection bit 8
9	Spot index selection bit 9
10	Spot index selection bit 10
11	Spot index selection bit 11
12	Spot index selection bit 12
13	Spot index selection bit 13
14	Spot index selection bit 14
15	Spot index selection bit 15

For further information please see the WMS manual.

Control Word 4

Control Word 2 defines the command (on/off) of the 16 outputs available on the card F378-IOE.

These outputs are fully managed by the user. The welding control has no type of control or protection over the data contained in this Control Word.

The maximum load values defined for the F378-IOE card must be respected.

If the F378-IOE card is not present in the welding control, the contents of the Control Word are ignored.

Command of the 16 outputs is updated every 10msec.

Bit	Description	F378-IOE P35- Contact
0	User defined Output 0	0
1	User defined Output 1	1
2	User defined Output 2	2
3	User defined Output 3	3
4	User defined Output 4	4
5	User defined Output 5	5
6	User defined Output 6	6
7	User defined Output 7	7
8	User defined Output 8	8
9	User defined Output 9	9
10	User defined Output 10	10
11	User defined Output 11	11
12	User defined Output 12	12
13	User defined Output 13	13
14	User defined Output 14	14
15	User defined Output 15	15

Control Word 4 - Functional description

Bit	Signal	Function
0/15	Output command	Bit=1. 24Vdc present on output. Bit=0. 24Vdc not present on output.

13.1.2 Status Word

Status Words indicate to the remote interface device the status of the welding sequence, and the status of the control and functionality of accessories in general.

Status Word 1

Status Word 1 defines the standard welding outputs

Bit	Description
0	END OF SEQUENCE
1	WELD ON FEEDBACK
2	KSR NOT USED
3	LINE SYNCHRO FAULT.
4	WELD PROCESS FAULT
5	TIMER READY
6	STATUS SVV
7	Not used
8	PREWARNING STEPPER 0
9	PREWARNING STEPPER 1
10	TIP DRESS REQUEST 0
11	TIP DRESS REQUEST 1
12	END OF STEPPER 0
13	END OF STEPPER 1
14	Not used
15	Not used

Status Word 1 – Functional description

Bit	Signal	Function
0	END OF SEQUENCE	Bit = 1. In "single spot" functioning, this indicates the end of the sequence, if the welding cycle has been completed without anomalies
1	WELD ON FEEDBACK	Bit = 1. Execution of "welding cycle with current" enabled. The welding cycle will be executed with current, therefore with command by the power group.
2	KSR NOT USED	Bit = 0. The diagnostic controls on the welding spot being performed are not active (normal welding mode or current). Bit = 1. The diagnostic controls on the welding spot being performed are active (Monitor or Constant Current welding modes).
3	LINE SYNCHRO FAULT	Bit = 1. Signals that the control cannot detect the signal for synchronisation with the grid voltage
4	WELD PROCESS FAULT	Bit = 1. During the last welding cycle, an anomaly in the welding process occurred. The bit is set to 0 after "reset alarm".
5	TIMER READY	Bit = 1. The welding control is ready to perform a welding cycle.
6	STATUS SVV	Bit = 1. Signals that the proportional valve has reached the requested setup value.
7	-	Not used.
8	PREWARNING STEPPER 0	Bit = 1. The programmed number of welds has been reached for the "electrode wear" warning of the electrode assigned to Stepper#0 (see electrode selection).
9	PREWARNING STEPPER 1	Bit = 1. The programmed to number of welds has been reached for the "electrode wear" warning of the electrode assigned to Stepper#1 (see electrode selection).
10	TIP DRESS REQUEST 0	Bit = 1. The number of welds programmed for electrode dressing has been reached for the electrode assigned to Stepper#0 (see electrode selection). The bit is set to 0 on confirming dressing has been performed.

Bit	Signal	Function
11	TIP DRESS REQUEST 1	<p>Bit = 1. The number of welds programmed for electrode dressing has been reached for the electrode assigned to Stepper#1 (see electrode selection).</p> <p>The bit is set to 0 on confirming dressing has been performed.</p>
12	END OF STEPPER 0	<p>Bit = 1. The programme and number of welds for electrode replacement has been reached, for the electrode assigned to Stepper#0 (see electrode selection).</p> <p>The bit is set to 0 on confirmation of electrode replacement.</p>
13	END OF STEPPER 1	<p>Bit = 1. The programme and number of welds for electrode replacement has been reached, for the electrode assigned to Stepper#1 (see electrode selection).</p> <p>The bit is set to 0 on confirmation of electrode replacement.</p>
14/15	-	Not used.

Status Word 2

Status Word 2 defines two Bytes included between bits 0-7 and bits 8-15 to communicate the diagnostic information, such as the active alarm code (FAULT CODE).

Bit	Description
0	Fault Code bit 0
1	Fault Code bit 1
2	Fault Code bit 2
3	Fault Code bit 3
4	Fault Code bit 4
5	Fault Code bit 5
6	Fault Code bit 6
7	Fault Code bit 7
8	Not used
9	Not used
10	Not used
11	Not used
12	Not used
13	Not used
14	Not used
15	Not used

Status Word 2 - Functional description

Bit	Signal	Function
0/7	Fault Code	With this byte the control communicates the active alarm code.
8/15	-	Not used.

Status Word 3

Status Word 3 defines two Bytes included between bits 0-7 and bits 8-15 to communicate the technological parameters necessary to manage an electric gun, such as electrode closing force (WELD FORCE) and the thickness of the part to be welded (ELEMENT THICKNESS).

Bit	Description
0	Weld Force bit 0
1	Weld Force bit 1
2	Weld Force bit 2
3	Weld Force bit 3
4	Weld Force bit 4
5	Weld Force bit 5
6	Weld Force bit 6
7	Weld Force bit 7
8	Element Thickness bit 0
9	Element Thickness bit 1
10	Element Thickness bit 2
11	Element Thickness bit 3
12	Element Thickness bit 4
13	Element Thickness bit 5
14	Element Thickness bit 6
15	Element Thickness bit 7

Status Word 3 - Functional description

Bit	Signal	Function
0/7	Weld Force	<p>With this byte the control communicates the value of the electrode force defined in the welding programme. It is a parameter that replaces the analog signal for application of the proportional servovalve. The field of regulation of the force is between 0-1275 daN (one bit is the equivalent of 5daN).</p>
8/15	Element Thickness	<p>With this byte the control communicates the element thickness defined via WMS and assigned to the welding spot. The field of regulation of the thickness is between 0-12.75 mm (one bit is the equivalent of 0.05mm). This parameter is located in the WMS, in the User Parameters area of the welding programme</p>



Please see the WMS programming manual.

Status Word 4

Status Word 2 contains the status of the 16 inputs available on the F378-IOE card.

These inputs are fully managed by the user. The welding control does not control or protect the data contained in this Status Word in any way.

The maximum load values defined for the F378-IOE card must be respected.

If the F378-IOE card is not present in the welding control, the contents of the Status Word are reset.

The status of the 16 inputs is updated every 10msec.

Bit	Description	F378-IOE P36- Contact
0	User defined Input 0	0
1	User defined Input 1	1
2	User defined Input 2	2
3	User defined Input 3	3
4	User defined Input 4	4
5	User defined Input 5	5
6	User defined Input 6	6
7	User defined Input 7	7
8	User defined Input 8	8
9	User defined Input 9	9
10	User defined Input 10	10
11	User defined Input 11	11
12	User defined Input 12	12
13	User defined Input 13	13
14	User defined Input 14	14
15	User defined Input 15	15

Status Word 4 - Functional description

Bit	Signal	Function
------------	---------------	-----------------

0/15	Input Status	Bit=1. 24Vdc present on input.
-------------	---------------------	---------------------------------------

Bit=0. 24Vdc not present on input.

APPENDIX

APPENDIX A - Maintenance

Maintenance operations

Replacing the cards is a very simple task which poses no problems.

The wiring connections with the welding machine cannot be exchanged between one another and the connector ID code is also recalled on the front panel.

To avoid doing wrong connections with similar connectors, DO NOT REMOVE the polarising device which is fitted to several connectors of the cards.

To make the connection of the card on the bus easier, it is better to strip the card pack from the container.

Always check whether jumpers are present on the card. If so, check they are done correctly.

Replacing the modular cards

1. Switch off the machine and disconnect wiring.
2. Disassemble the control device from the machine support.
3. Remove the front panel by undoing the 3 fastening screws.
4. Disconnect the card to be replaced paying utmost care in doing this operation.

Front part fastening screws

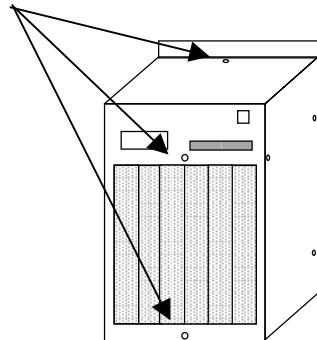

5. Check on the new card for the presence of jumpers and, if need be, set them in the correct way.
6. Fit the new card into the rack and make sure that the P7 3-way connector fits correctly into the bus.
7. Put the card pack in place again in the container and fasten it by using its screws.
8. Re-install the front part making sure that the PS connector fits properly into the window then screw down the front part.
9. Re-install the control device onto the machine.
10. Connect wiring again.

Replacing the CPU card

The CPU card has its own (compulsory) position on the P1 of the bus and is connected to the display module via a 10-way flat cable.

The P7 3-way connector does not take 24V I/O supply from the bus, it takes the privileged power supply to power the programming unit from the RS485 port (P1).

How to replace the card:

1. Switch off the machine and disconnect wiring.
2. Disassemble the control device from the machine support.
3. Remove the front panel by undoing the 3 fastening screws.
4. Disconnect the card to be replaced paying utmost care in doing this operation.
5. Disconnect the display connector from P3. Pay utmost attention in doing this.
6. Check if the new card is fitted with the buffer battery for the permanent memory. Verify jumpers on the connectors JP3 and JP6; they must be as follows:
JP3: 3-4 and 6-7 jumpers JP6: 1-2 jumper
7. Connect the display flat cable to P3 connector.
8. Insert the new card onto the bus making sure that the P7 connector is fitted correctly.
9. Put the front part in place again making sure that the PS connector fits correctly into the window then fasten the front panel with the screws.
10. Re-install the control device onto the machine.
11. Connect wiring again.

Replacing the power feeder

The power feeder card can be easily replaced. Check that the internal 250V, 1.5A fuse for 24VE supply is present before installing the new card.

How to replace the card:

1. Switch off the machine and disconnect wiring.
2. Disassemble the control device from the machine support.
3. Remove the front part buy undoing the 3 fastening screws.
4. Remove the 5 screws fastening the power feeder to the fastening brackets.
5. Disconnect the power feeder from the bus.
6. Check that network sync jumpers on the power feeder are set in the correct way (internal or external, see paragraph 3.4).
7. Connect the new power feeder making sure it fits properly into the connectors J1 and J2 of the bus.
8. Screw it down.
9. Put the front part in place again making sure that the PS connector fits correctly into the window then fasten the front part with the screws.
10. Re-install the control device onto the machine.
11. Connect wiring again.

Replacing the welding control device

Times indicated refer to a manual welding station

1	Saving the configuration and programs of the control device to be replaced on a Ram-Card	1 Minute
2	Dismantling the control device to be replaced from the welding machine support	3 Minutes
3	Mounting the new control device	3 Minutes
4	Switching On the new control device and verification that no diagnostics alarms are On	1 Minute
5	Inserting the Ram-Card and loading the programs and the configuration of the new control device	1 Minute

Time for replacing the device totals to 9 minutes (approx.).

Modifying a welding program:

The operation is to be carried out by qualified personnel with optimum knowledge of the control device programming.

Time taken up to modify a program depends on the entity of the change:

If only one parameter is to be modified, for instance the welding current value, the operation will take about 45" via the HCM4300 programming unit.

By contrast, if more parameters are to be modified, time can be calculated averagely, by adding approx. 30" for opening the menu concerned to approximately 10" for each modified parameter.

Time for modifying 1 parameter : 45" ~

Time for modifying "n" parameters : 30" + 10 x n

Replacing the battery

3.6V CR2477N type lithium battery.

The battery is housed on the F384 CPU card in an adequate seat which allows the battery to be replaced easily with no need for special operations.

When replacing the battery, data stored on the RAM are not lost. A Supercap type capacitor powers RAMs during the replacement.

Check that the new battery provides the correct voltage before mounting it onto the card. To do this use a tester.

How to replace the battery:

1. Switch off the machine and disconnect wiring
2. Disassemble the control device from the machine support
3. Remove the front part by undoing the 3 fastening screws
4. Draw out the card located sideways the CPU card
5. Disconnect the F384 CPU card and draw it out tilting it sideways
6. Disconnect the small cable of the display
7. Remove the battery clip
8. Draw out the down battery
9. Insert the new battery
10. Mount the clip *
11. Connect the small cable of the display and, tilting the card sideways, fit it into the slot
12. Insert the card close to the F384-CPU making sure that the P7 fits correctly.
13. Put the front part in place again checking that the PS connector fits into the window then fasten the front part by using the screws
14. Re-install the control device onto the machine
15. Connect wiring again

* It is of paramount importance that the battery clip be always fitted.

APPENDIX B – Diagrams and network configurations

Operating diagrams

This section illustrates a few operating diagrams of the control device which allow analysing timing and synchronisms referred to the **Start** and **Emergency** conditions in manual or automated environments.

1 – START recognition with use in automated environment

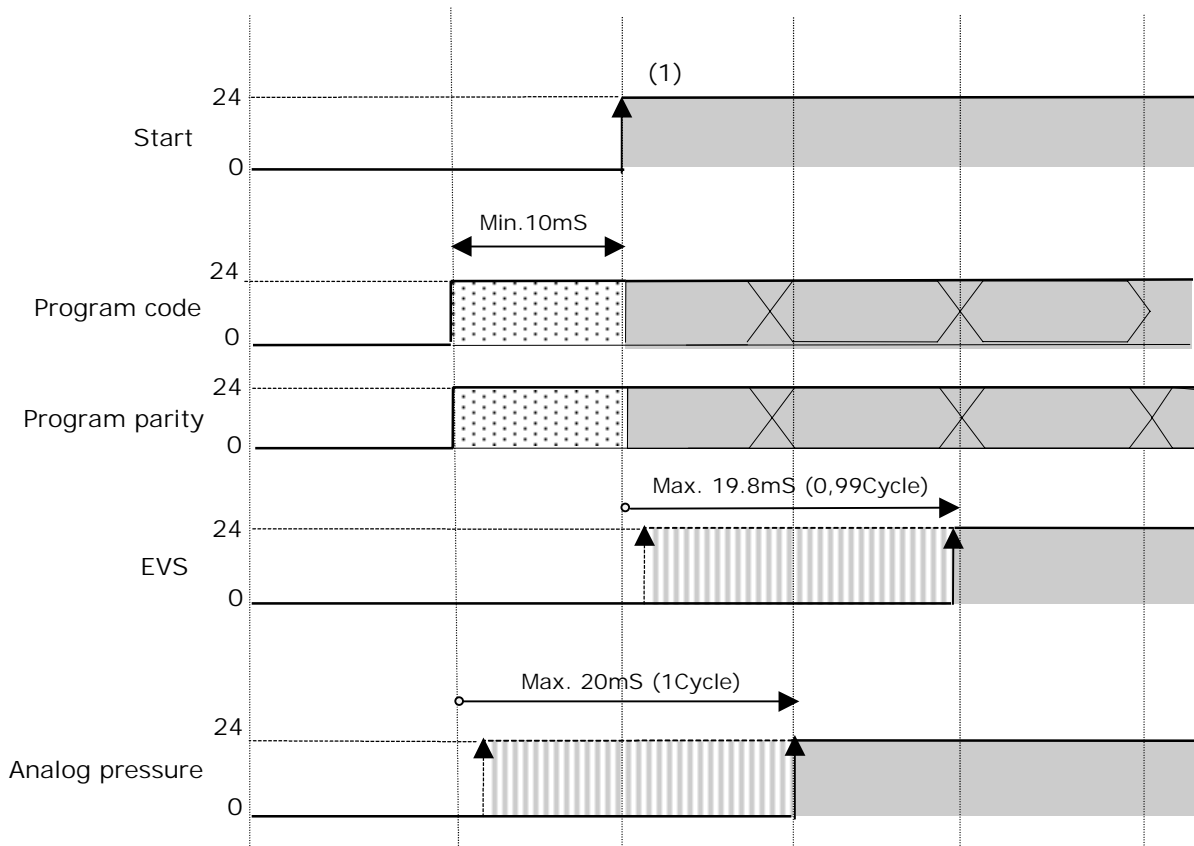

(1) The program code is saved. Any successive changes have not effect.

2 – START recognition with use in manual environment

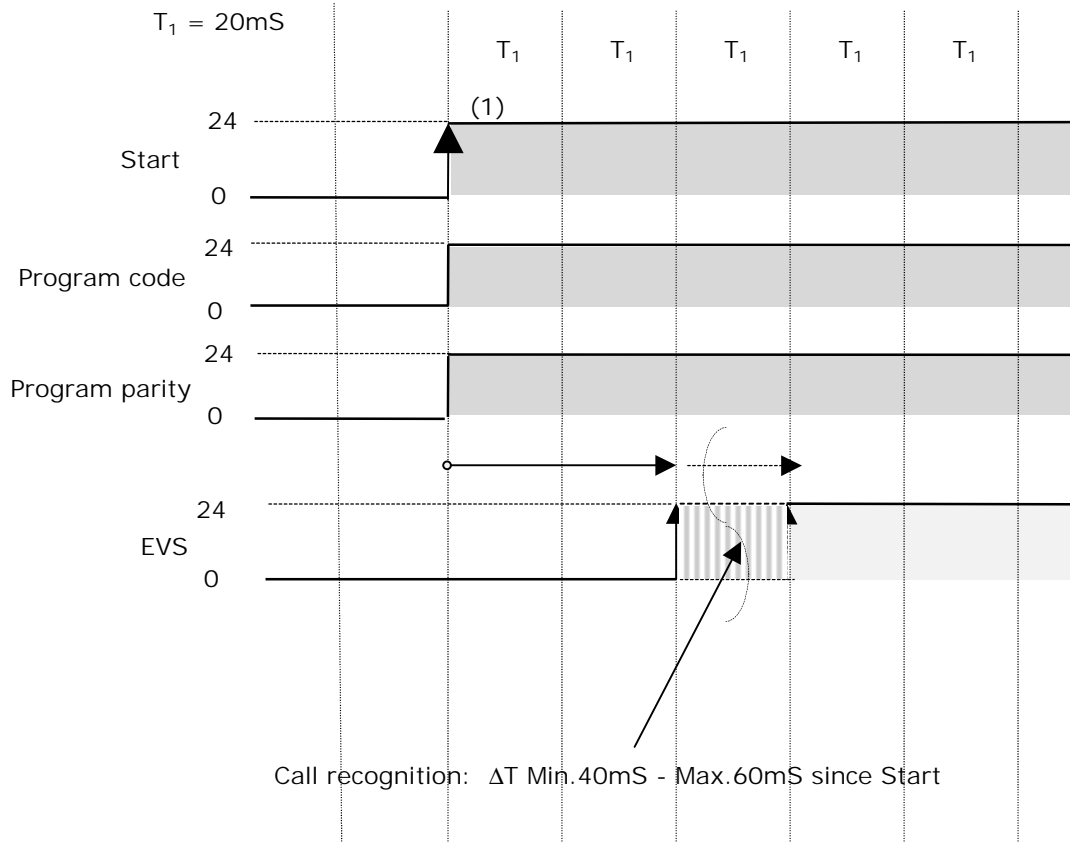

(1) Start and Program Code must stay stable.

3 – EMERGENCY STOP condition : general diagram

NOTE: The Emergency stop signal is active at 0V

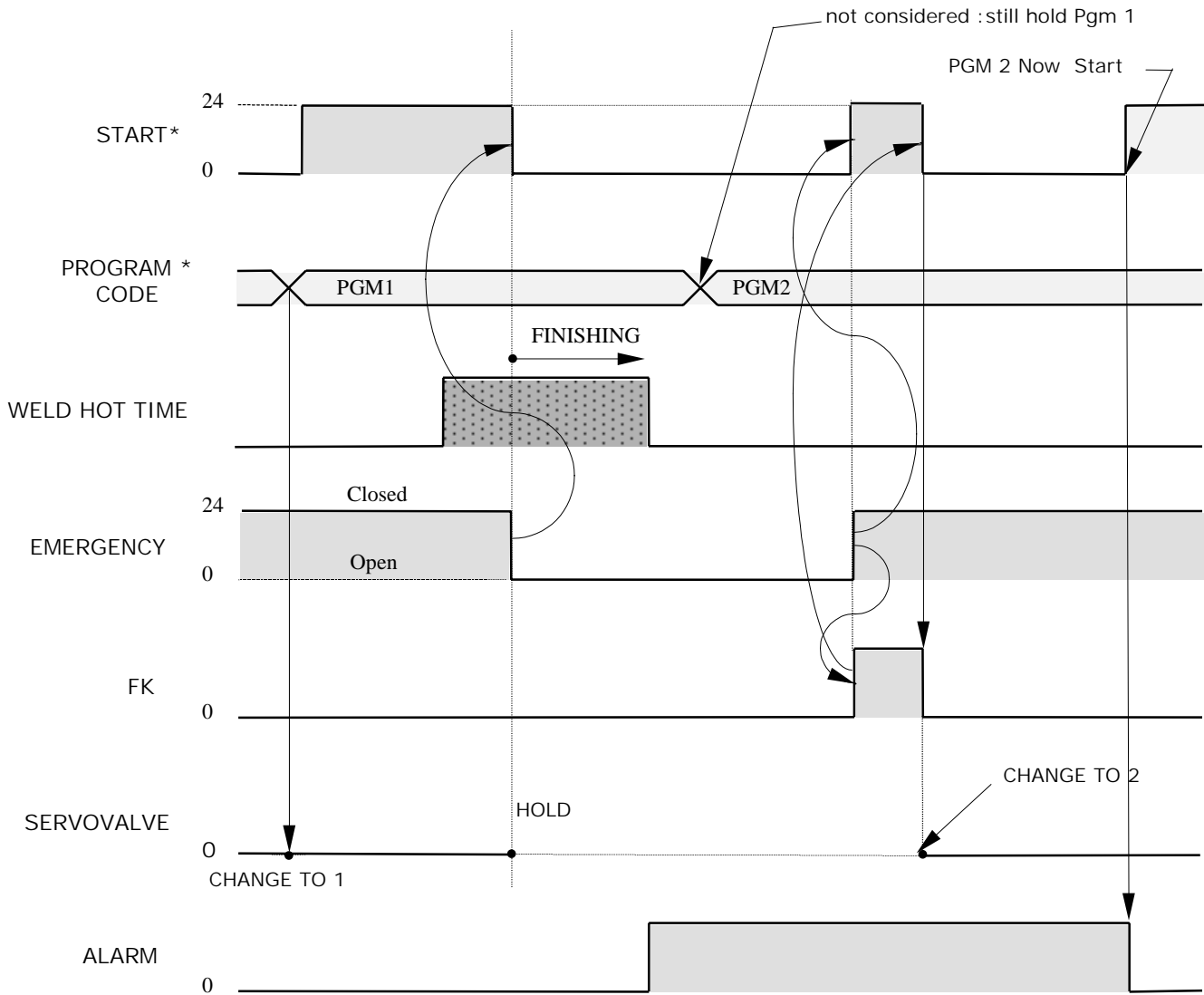

* Given by robot

4 – EMERGENCY STOP condition during or outside the welding pulse

NOTE: The Emergency stop signal is active at 0V

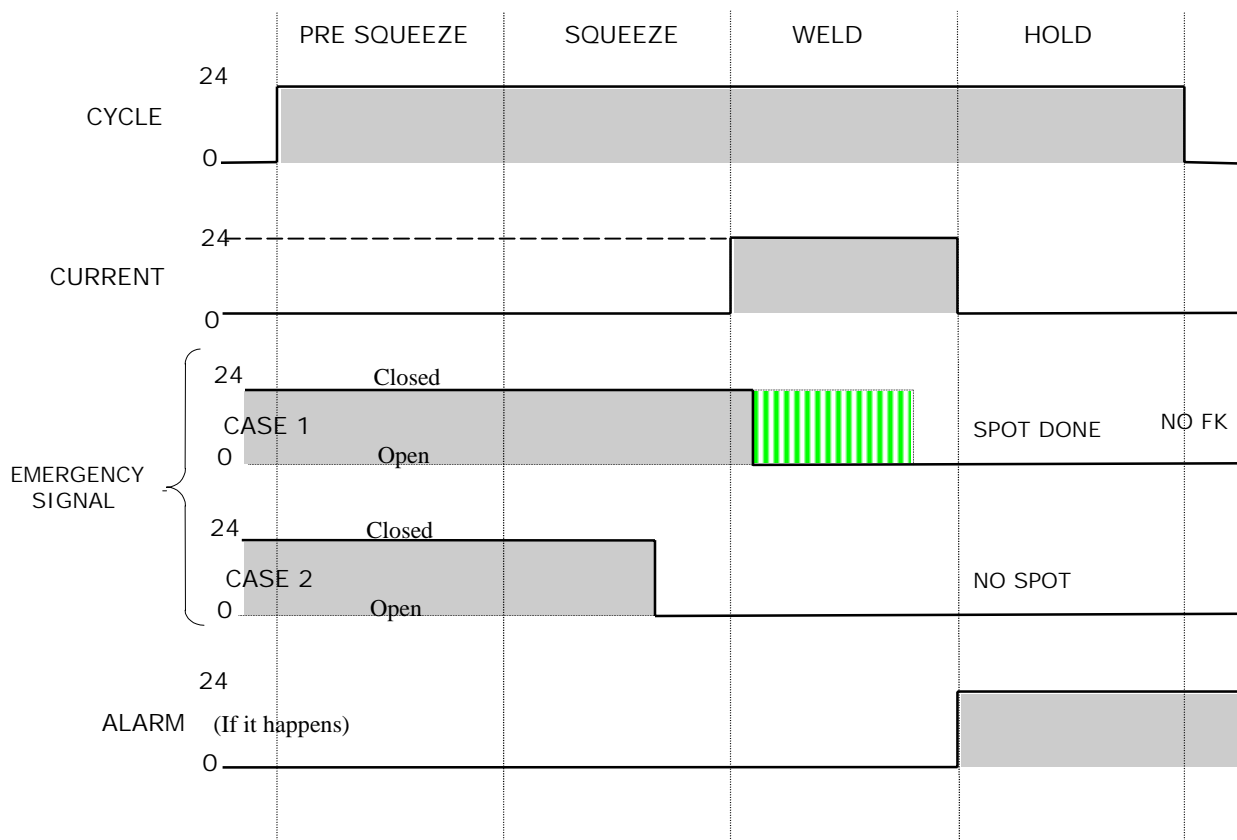

During emergency time-period situation the welding control behaviour will be:

- A started spot must be ended. In case of bad quality spot, with retry function programmed, all required retry-spots must be done
- If a quality spot alarm occurs it can be reset by PC or HHT
- NO dedicated message is generated/stored, to indicate the situation
- This situation is not to be considered an emergency but just a standard cycle operation, during that, all process have to be suspended

5 – EMERGENCY STOP excluded with START still active

NOTE: The Emergency stop signal is active at 0V

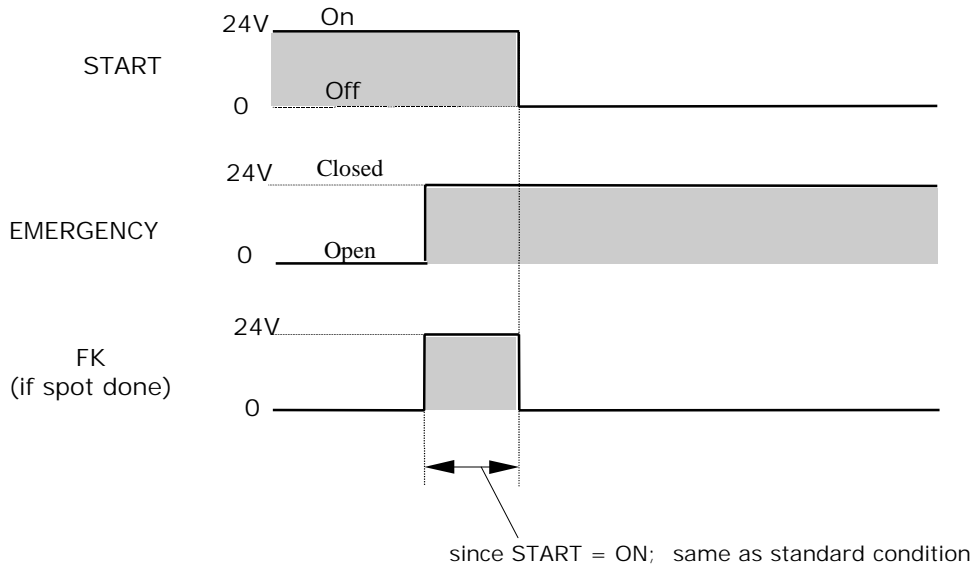

6 – START disabled condition during the welding pulse

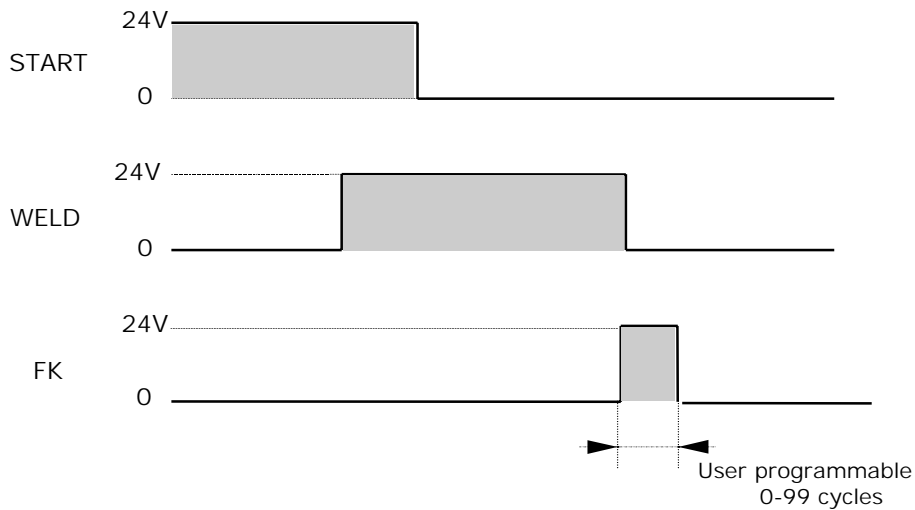

7 – Proportional Servovalve operating diagram

Servovalve parameters description:

- OFFSET : 0 - 100 % (active only after a reset; until a start cycle) Stored in Setup function
- EV1 : 0 - 100 % Nominal value during welding cycle Stored in each program
- EV2 : 0 - 100 % Pressure variation value. Stored in each program

Change is done after n cycles; and in mode according the 5 available profiles

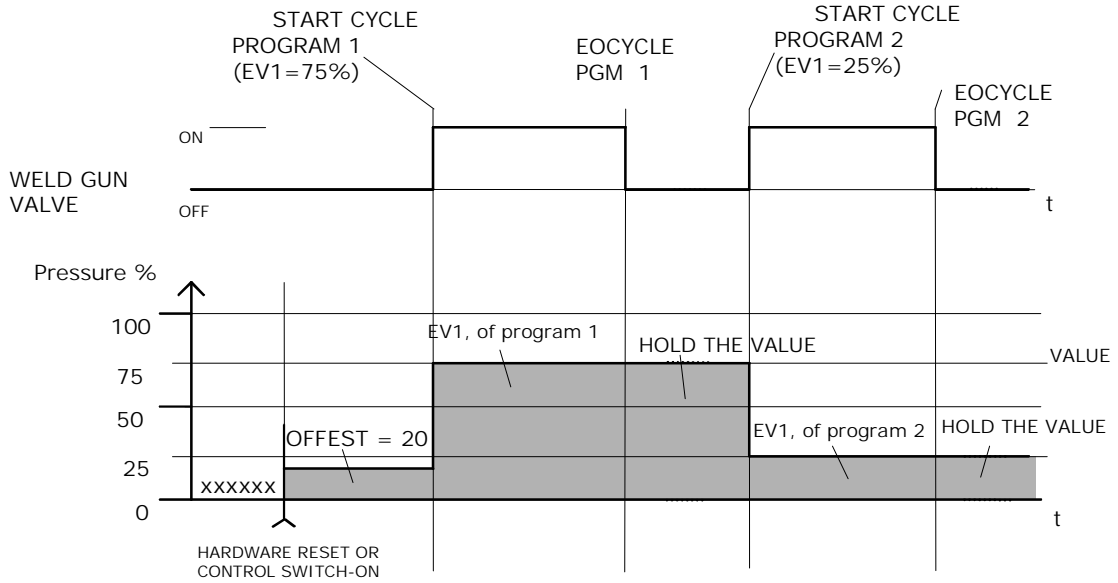

Pressure % = Output air pressure, percentage of input pressure.

- Examples: with: 5 bar input & EV1 @
- 50 %; servovalve output = 2,5
 - 75 % " " = 3,75
 - 100 % " " = 5 bar (servovalve drop not considered)

When the weld program code change (at the physical discrete inputs, or by serial line fieldbus as Interbus-S or Profibus DP or DeviceNet) immediately the servovalve command output will be updated according the EV1 value stored in the program choosed. Also without the Start signals. This function is always active.

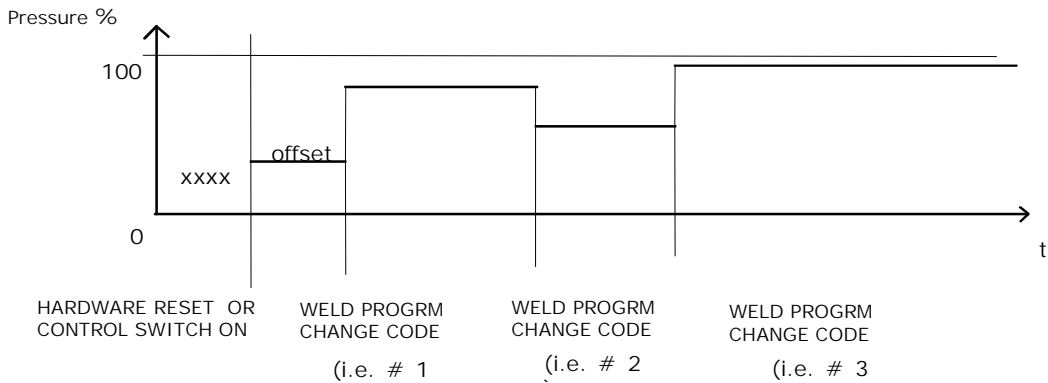

All changes without start cycle command

8 – ENABLE function (Interbus-s)

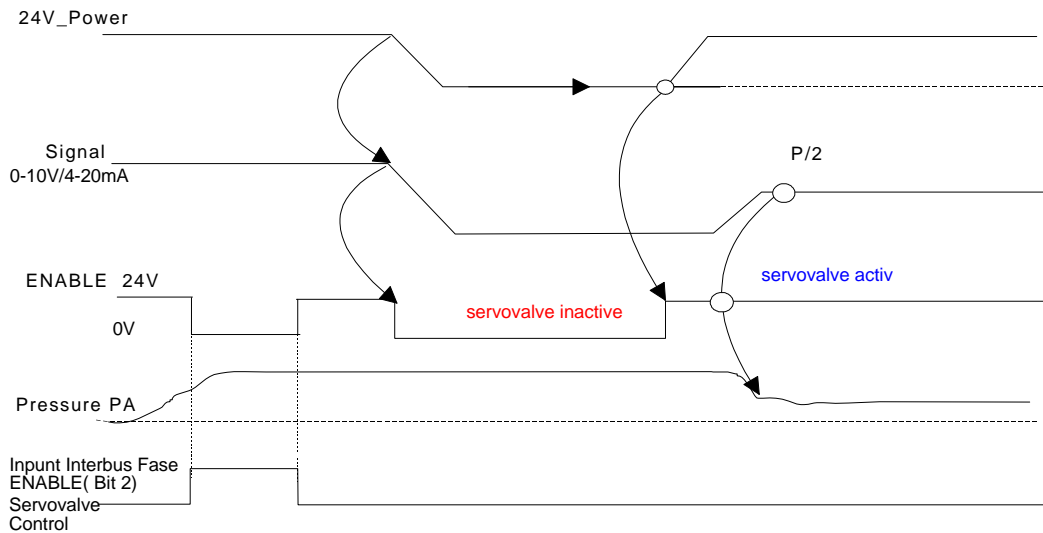

Signal behaviour:

ENABLE 24V: This function allows the valve control when voltage power supply interrupts (Fail save); the output current pressure is not modified.

Servovalve control Interbus input: This function allows the servovalve piloting to be done through the Interbus control input (Active High = ENABLE goes to 0V ->): pressure stays unchanged.

9 – Diagram of diagnostic pressure control

Mode of operation relates to the status of the programming parameter PROC / WAIT (see programming Manual, paragraph *Electrode Force Diagnostic Mode*)

Process in PROC mode

The control executes the sequence respecting the set timings. The diagnostic function signals any pressure errors.

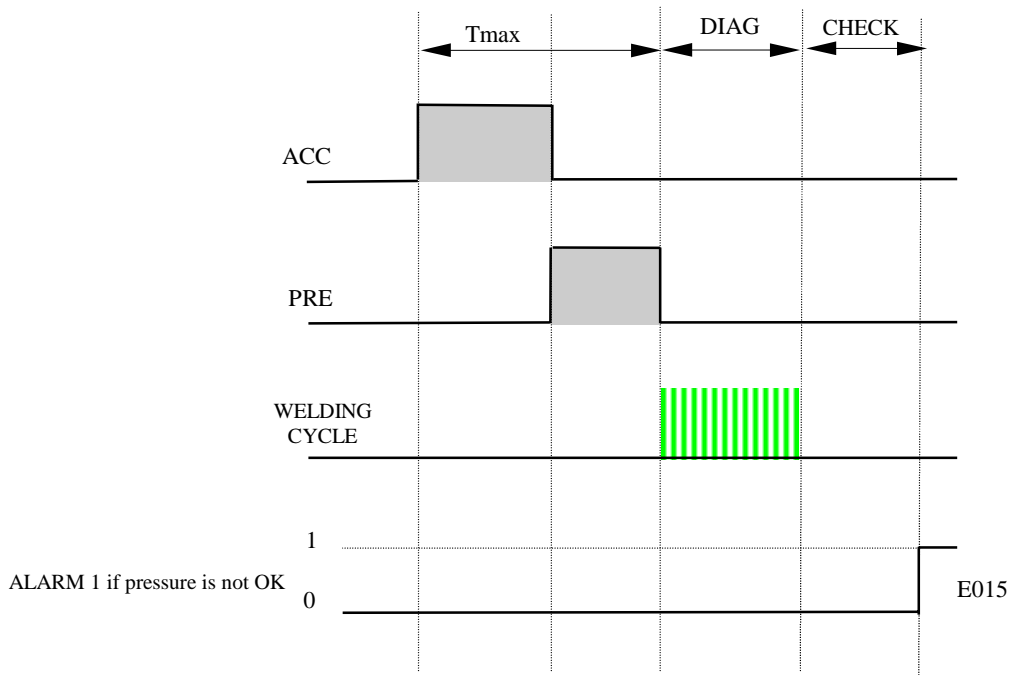

Process in WAIT mode

The welding pulse is only given when the nominal value P1 has been reached

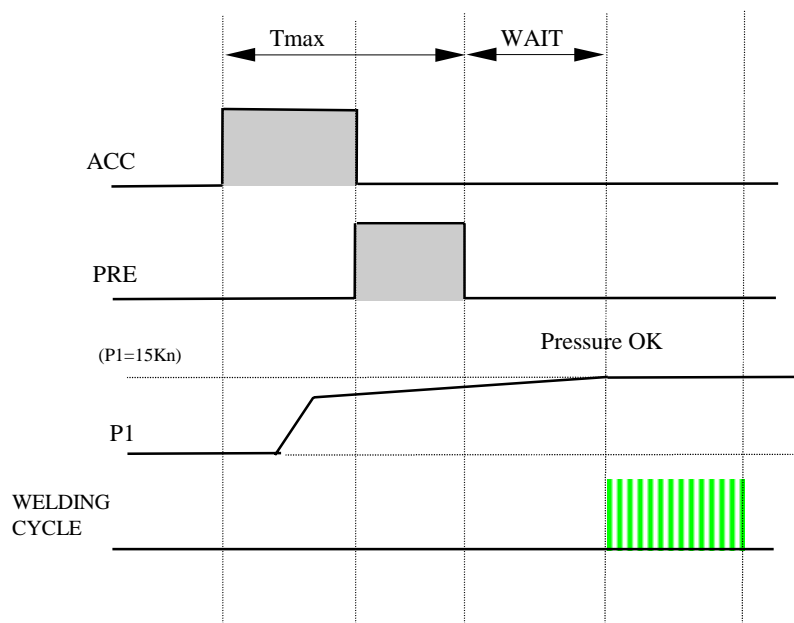

NOTE: When the parameter %T. Prs = 0 the function is disabled

Interbus-S –general architecture of I/O communications.

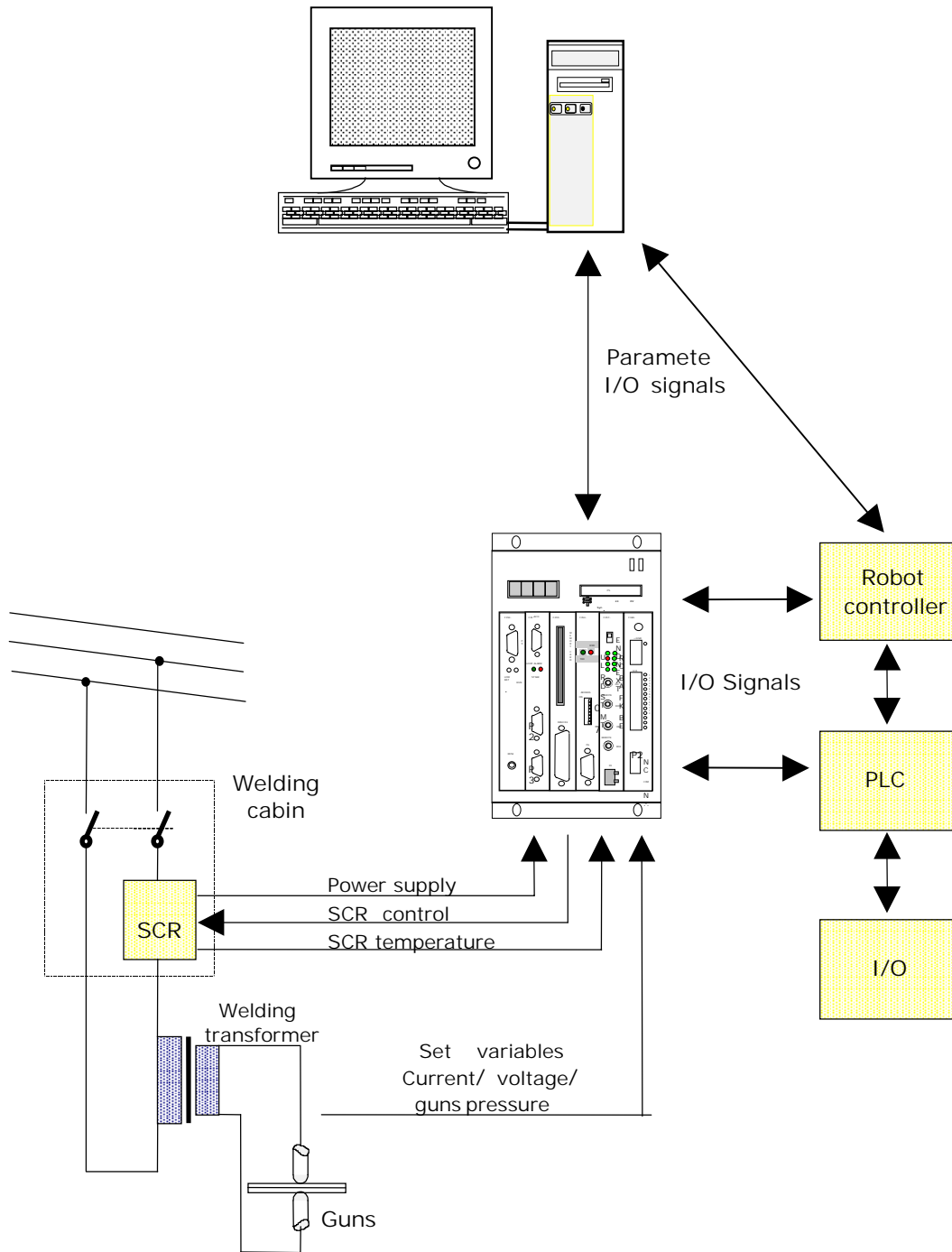

Ethernet Tcp/Ip – Example of network architecture

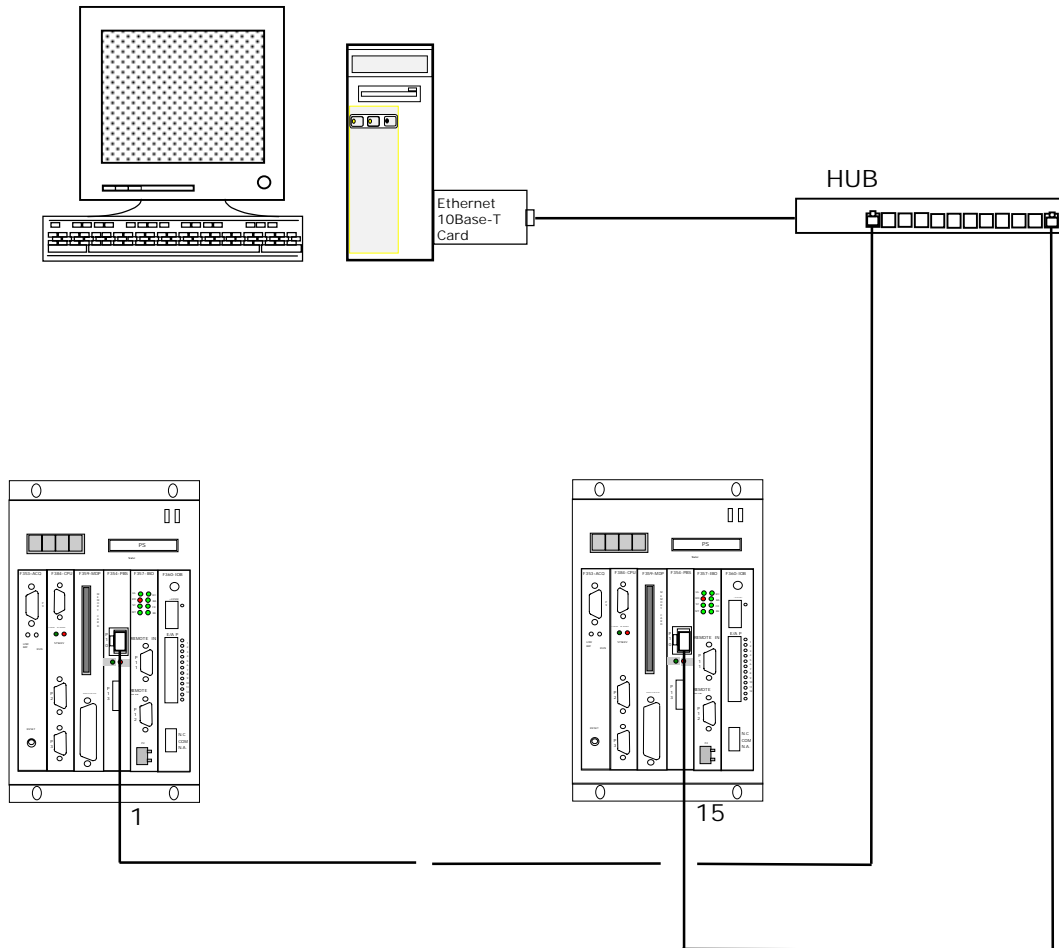

A maximum of 127 controls can be connected.
 Signal connection depends on the type of port present on the HUB, which can be of the MDI or of the MDI-X type.

InterBus-S- Example of network architecture

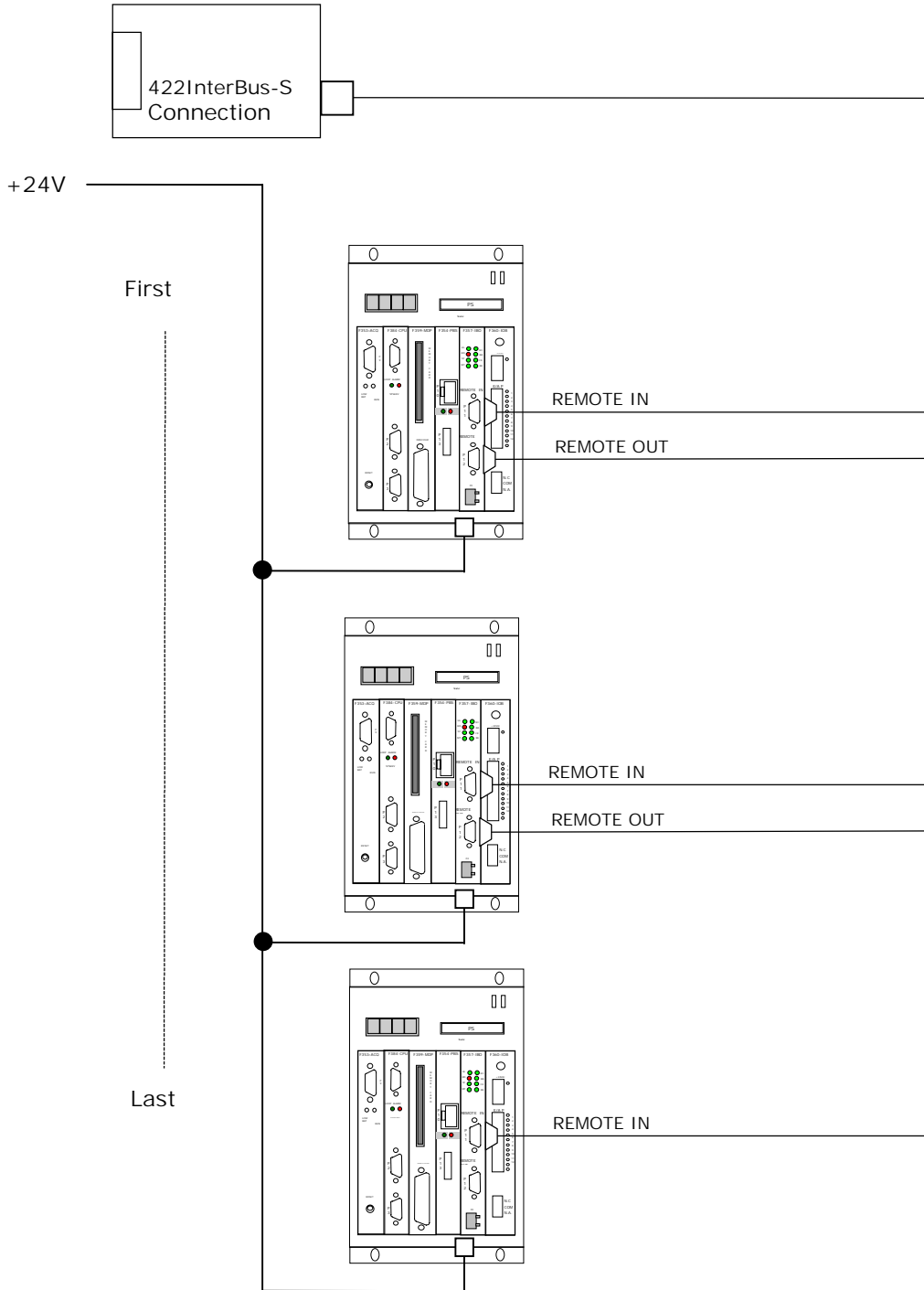

APPENDIX C - Weld334m Application diagram

Dwg. 33033323/01
Dwg. 33033324/01
Dwg. 33033339/02
Dwg. 33033340/00

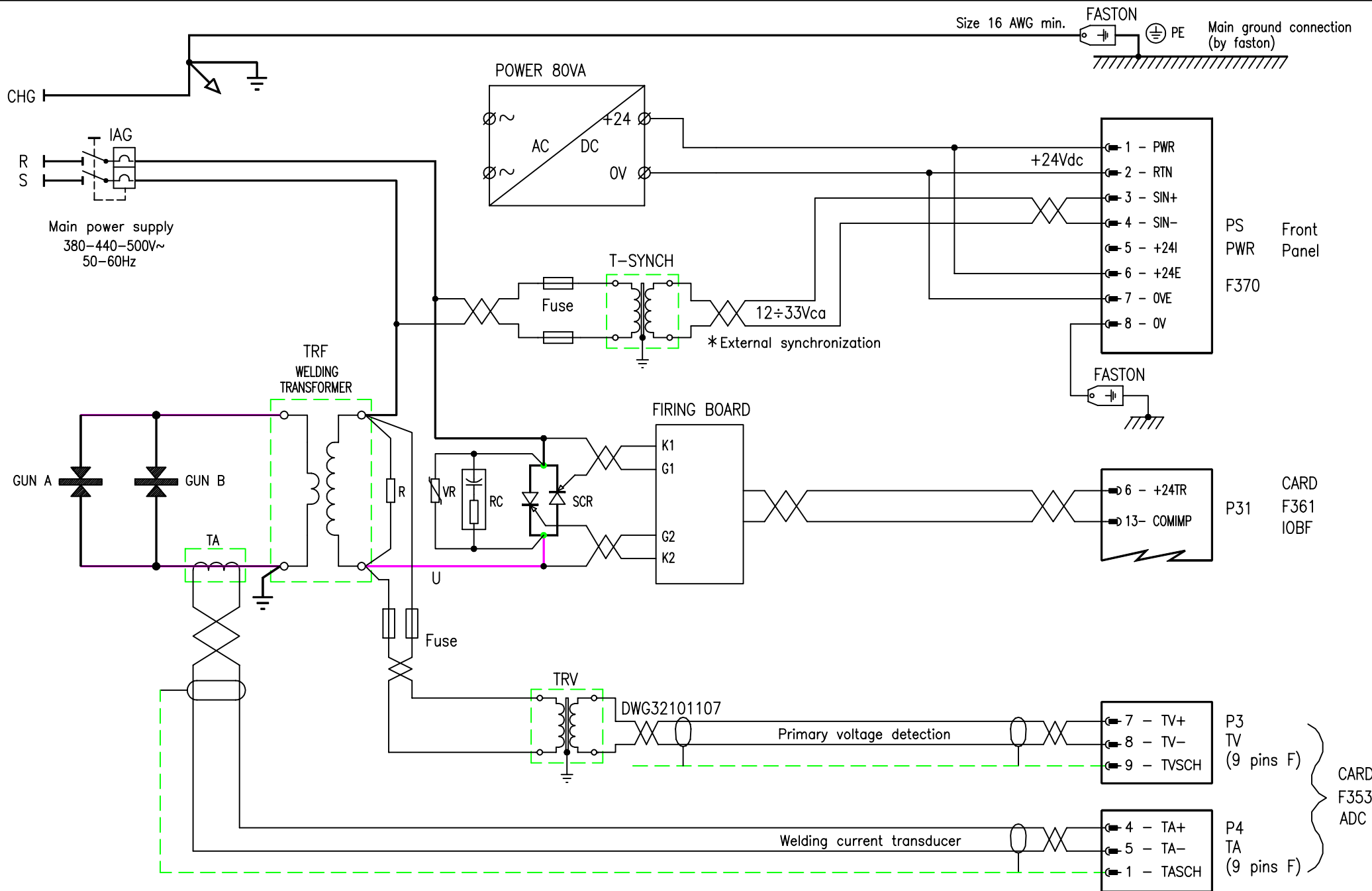

* External Synchro: it's used when the power and the control are connected to different phases;
 or when the control is connected to the 24Vdc power supply.
 To use the external synchro line mode, is necessary position switch change
 on the power supply board

Part#	Qty.	Descr.	Mater.	Gen.#	Q.for gen.	Changement
		WELD334m Fiat type		Date 02/98	Scale	Code
CONNECTIONS POWER 24Vdc, FIRING AND TRANSDUCERS				Sheet n. 1	#of sheet 1	Author T.G.
				Draw n. 33033323/ 01		Fmt.
All proprietary rights reserved by Spa FASE. This drawing will not be reproduced or in any way utilized for the manufacture of the component or herein illustrated and must not be released to other parties without written consent. Any infringement will be legally pursued.						

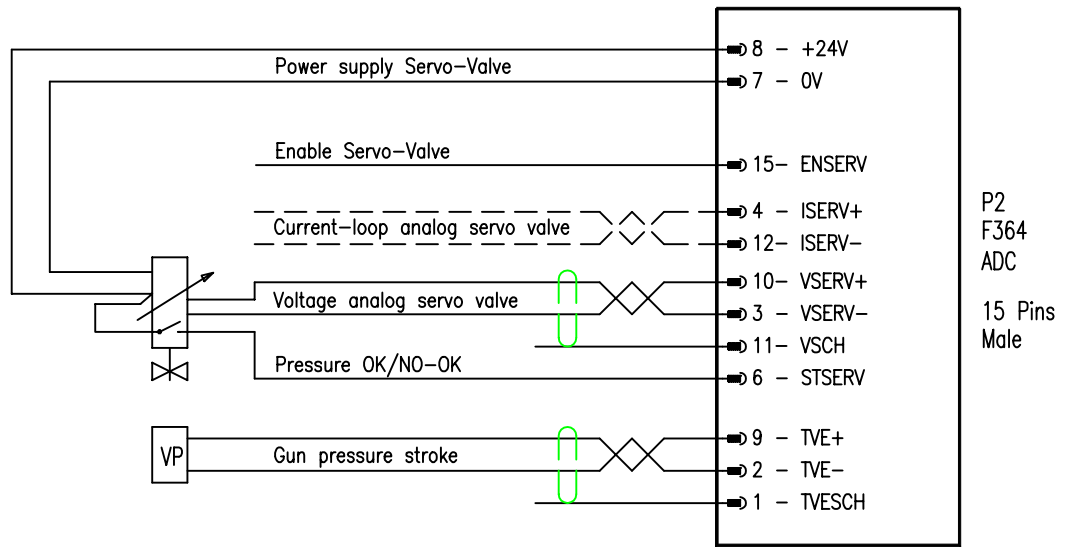

Y- RS485 Y- SIGNAL
 Y+ RS485 Y+ SIGNAL
 XGND RS485 COMMON
 TNETDW RS485 Y- TERMINATOR
 TNETUP RS485 Y+ TERMINATOR
 ADR4 BIT 4 WMS NET ADDRESS
 ADR2 BIT 2 WMS NET ADDRESS
 ADR0 BIT 0 WMS NET ADDRESS
 Y- RS485 Y- SIGNAL
 Y+ RS485 Y+ SIGNAL
 XGND RS485 COMMON
 ADRCOM WMS NET ADDRESS COMMON (0V)
 ADRP BIT PARITY WMS NET ADDRESS
 ADR3 BIT 3 WMS NET ADDRESS
 ADR1 BIT 1 WMS NET ADDRESS

1 - Y-
 2 - Y+
 3 - XGND
 4 - TNETDW
 5 - TNETUP
 6 - ADR4
 7 - ADR2
 8 - ADR0
 9 - Y-
 10 - Y+
 11 - XGND
 12 - ADRCOM
 13 - ADRP
 14 - ADR3
 15 - ADR1

P7
 F355
 NET
 15 Pins
 Female

Part#	Qty.	Descr.	Mater.	Gen.#	Q.for gen.	Changement
WELD334m Sub-d type				Date 06/98	Scale -	Code
CONNECTIONS CARD "F364" SERVO-VALVE AND				Sheet n. 1	#of sheet 1	Author T.G.
"F355" WMS-NET				Draw n. 33033324/01	Fmt. -	
<small>All proprietary rights reserved by Spa FASE. This drawing will not be reproduced or in any way utilized for the manufacture of the component or herein illustrated and must not be released to other parties without written consent. Any infringement will be legally pursued.</small>						

+24Vdc

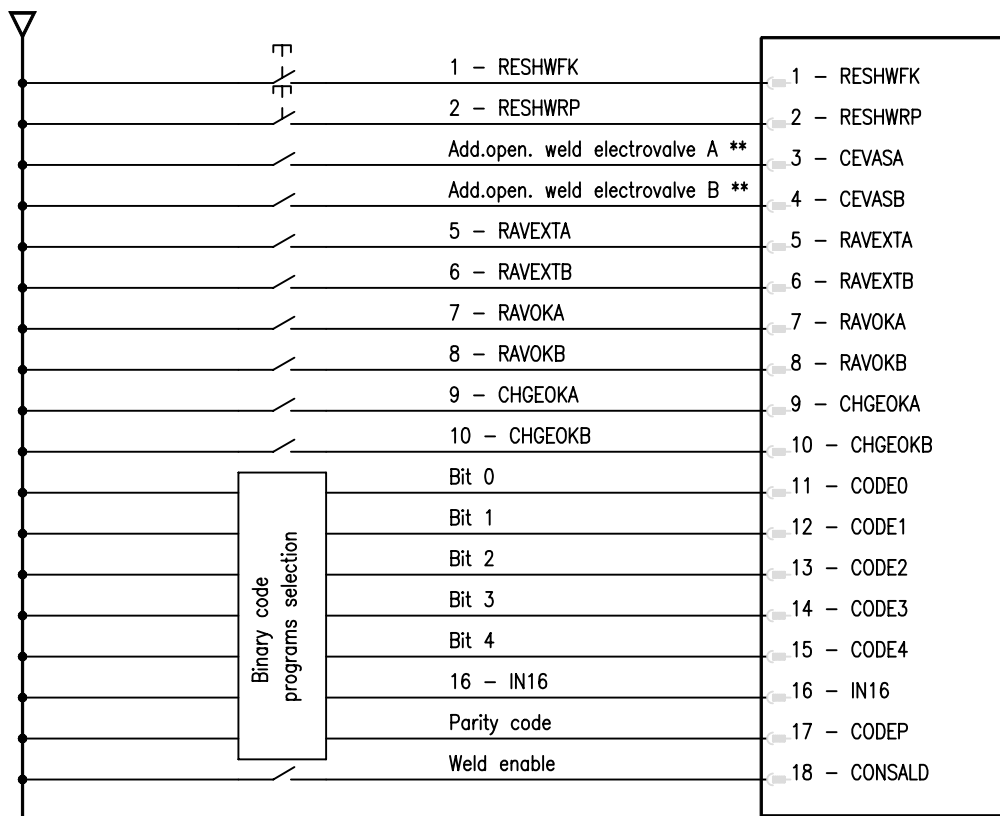

P43
F393
IOE

0V

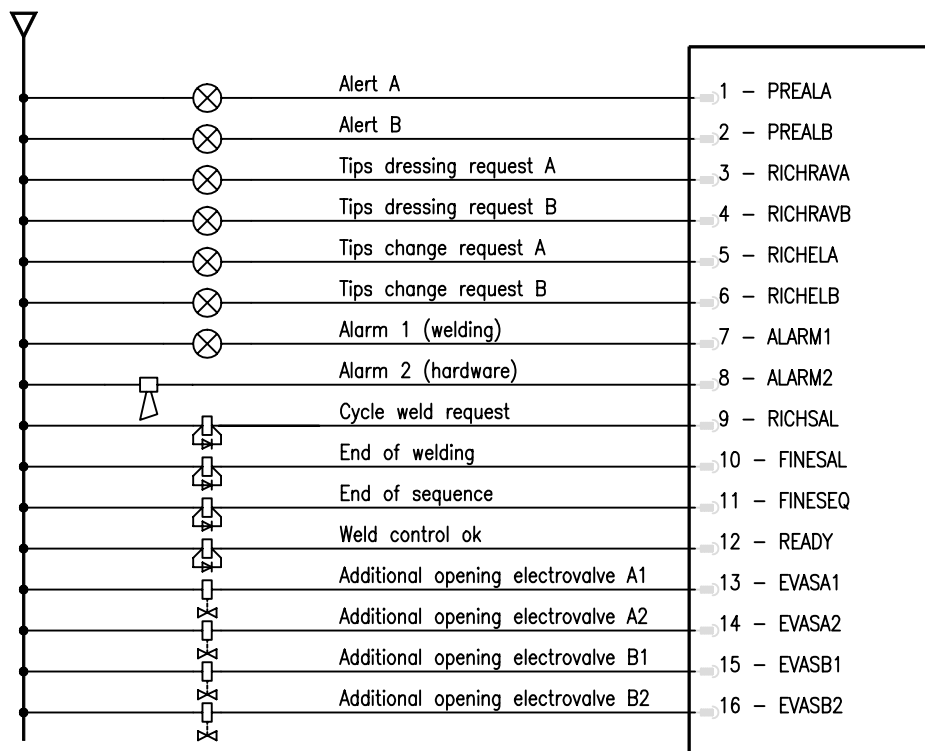

P42
F393
IOE

Short to +24Vdc when the functions are not utilized

Part#	Qty.	Descr.	Mater.	Gen.#	Q.for gen.	Changement
WELD334m Terminal block				Date 06/02	Scale -	Code
CONNECTIONS CARD "F393" IOE				Sheet n. 1	#of sheet 1	Author T.G.
				Draw n. 33033339/02	Fmt.	-
<small>All proprietary rights reserved by Spa FASE. This drawing will not be reproduced or in any way utilized for the manufacture of the component or herein illustrated and must not be released to other parties without written consent. Any infringement will be legally pursued.</small>						

Circuit breaker command
emergency main switch (IAG)
max 110Vac 300VA

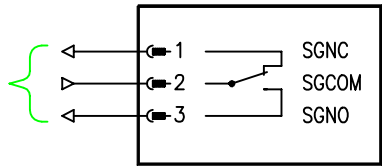

P22
F392
IOB

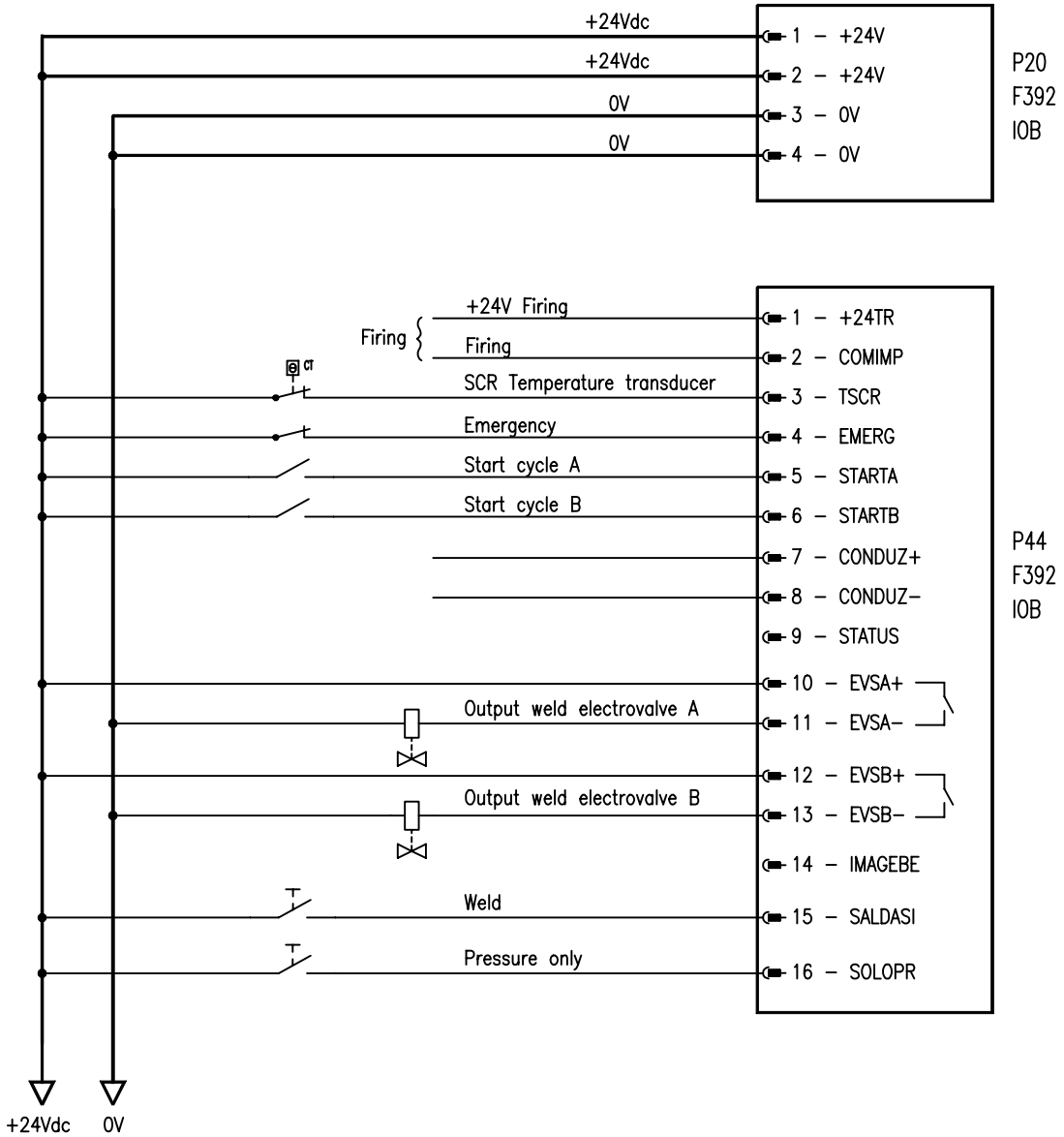

Part#	Qty.	Descr.	Mater.	Gen.#	Q.for gen.	Changement
WELD334m Terminal block				Date 06/02	Scale -	Code
CONNECTIONS CARD "F392" IOB				Sheet n. 1	#of sheet 1	Author T.G.
				Draw n. 33033340/00	Fmt.	-
<small>All proprietary rights reserved by Spa FASE. This drawing will not be reproduced or in any way utilized for the manufacture of the component or herein illustrated and must not be released to other parties without written consent. Any infringement will be legally pursued.</small>						