

  
**BAUMÜLLER**



**be in motion be in motion**

**GN...N**

**DC Motors**



**Table of Contents**

General ..... 2  
Performance Definition ..... 4  
Type Selection ..... 6  
Preferred Types ..... 6  
Type Code ..... 7  
Technical Data ..... 8  
Bearings and Shaft Loading ..... 36  
Radial Force Diagrams ..... 37  
Connection - Terminal Designation ..... 43  
Temperature Monitoring ..... 44  
Brush monitoring ..... 44  
Noise level ..... 45  
Vibration severity ..... 45  
Cooling ..... 46  
Brake assignment ..... 47  
Encoder ..... 48  
Structural forms ..... 49  
Dimensional drawings ..... 50  
Encoder leads for pulse encoders ..... 56

## General

Baumüller **GN...N** DC motors are manufactured in IEC axle heights of between 100 and 280.

### Structure

The motors are fully laminated and have four poles. They are uncompensated and insulation is of class H. On request, we can also produce axle heights of 180 – 280 compensated too.

As standard, **GNA ..N** DC motors are designed with mounted radial forced ventilation of IP23 type of protection.

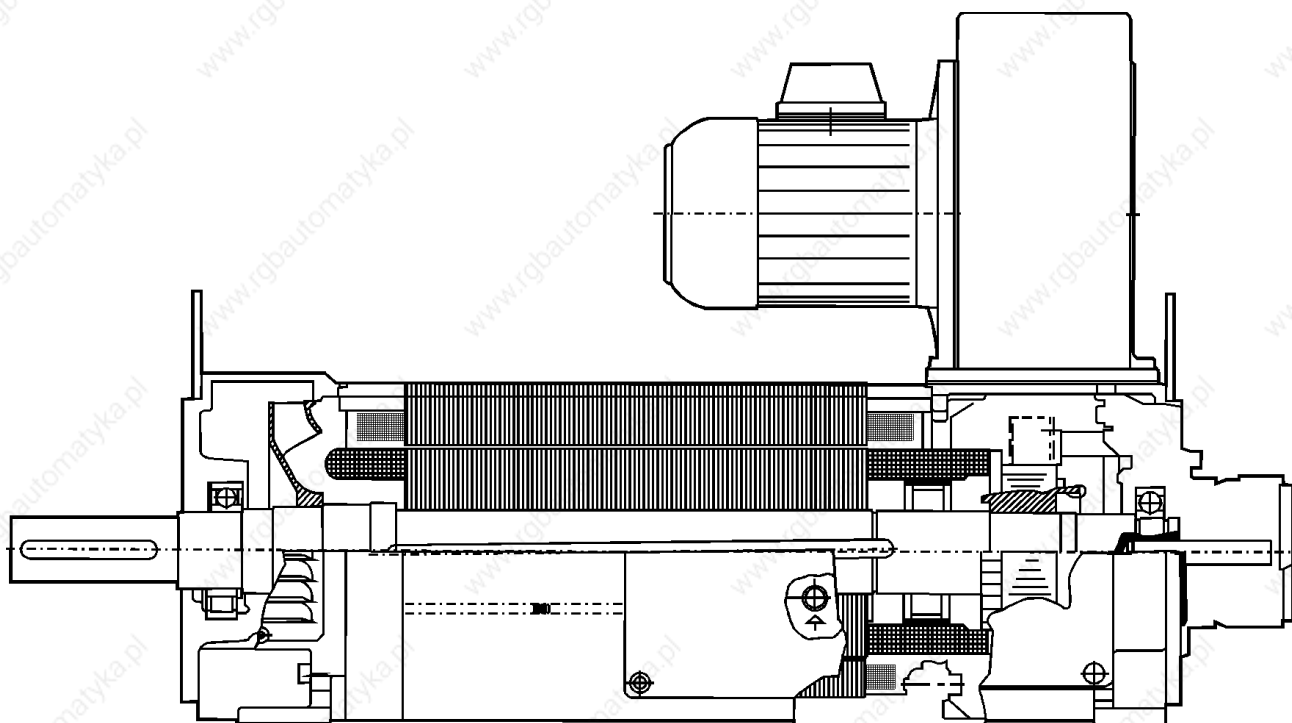

GN ... .N



Version EN60034	IM B3 IM B5 IM B35 IM V1 IM V3	horizontal mounting for size 100-280 horizontal mounting for size 100-160 horizontal mounting for size 100-280 vertical mounting, shaft end to the bottom vertical mounting, shaft end to the top
Type of protection	IP23	internally cooled, <b>with</b> fan (IP20 for version V)EN60034-5
Connection: Main connection		Terminal box
Control connection		Tachometer conn. (option pulse encoder, 12-pin connector)
Brake		inside terminal box
Thermal sensor		inside terminal box
Type of cooling	IC 06	internally cooled machine with fan
Thermal sensor		2 thermal relays
Temperature rise		$\Delta\theta = 125\text{ K}$ insulation class H acc. to EN 60034
Temperature range	0...+ 40° C,	
Storage	-30° C...+85° C	
Paint		RAL 7001, 9005, 6011, 7015, 7032 (primed)
Bearings	$\geq 20,000\text{ h}$	Service life
Balance quality	N	acc. to DIN EN 60034 -14
	R, S	On request
Vibration-resistant up to	3g	Higher vibration-resistance on request
Flange		acc. to IEC standard 42948. Axial or radial tolerance acc. to DIN 42955N option R
Shaft end	cylindrical	acc. to DIN 748 with keyway DIN 6885; centring with internal thread acc. to DIN 332 form D (also available without keyway);Dim. d:Tolerance (without keyway h6)
Holding brake	Optional	
Actual speed encoder	DC Tacho	Incremental encoder (optional) Other encoders on request

## Performance Definition

The power output stated in the list applies to continuous running duty (S1) at nominal speed, at a maximum ambient temperature of 40° C and at a site altitude of less than 1000 m above sea level. The armature circuit is fed with direct current whose harmonic content does not exceed 25%.

You must operate the motor close to the nominal working point. Running the motor for a relatively long period of time and reaching less than 60% of the nominal power results in underload operation. You must ask the manufacturer to take special measures for this, otherwise the full warranty cannot be granted.

If motors are to be operated at an ambient temperature of more than 40° C or at site altitudes of more than 1000 m above sea level, the required list power  $P_L$  is the product of factors  $k_1$  or  $k_2$  and the required power  $P$ .

Ambient temperature	40° C	45° C	50° C	55° C	60° C
Correction factor $k_1$ approximately	1	1.06	1.13	1.22	1.34
Altitude above sea level up to	1000 m	2000 m	3000 m	4000 m	5000 m
Correction factor $k_2$ approximately	1	1.07	1.16	1.27	1.55

At ambient temperatures above 40° C and with motors of enclosed design, contact the manufacturer for any design modifications that may be required

In the case of sites above 1000 m where the ambient temperature drops by approx. 10° C per 1000 m, power correction is not necessary.

## Operating Modes

Please inquire at the factory about motors for intermediate periodic loading (S 3), continuous duty with intermittent loading (S 6), short-time duty (S 2) and about motors for switching operation (S 4, S 5, S 7). If necessary, please quote operating and break times, torques, transformation ratios etc. inquire at the factory. You can roughly calculate as shown below the necessary list power,  $P_L$  from the product of  $k_4$  and the required power output  $P$  for operating modes S 2, S 3 and S 6:

Intermediate periodic loading S 3 with ED	15%	25%	40%	60%
With internally cooled machines	0.6	0.7	0.8	0.9
Continuous duty with intermittent loading S 6 with ED	15%	25%	40%	60%
With internally cooled machines factor $k_4$	0.6	0.6	0.65	0.8
Short-time duty S 2 with ED	10 min	30 min	60 min	90 min
With internally cooled machines factor $k_4$	0.6	0.73	0.9	0.96

## Winding Insulation and Heating

All the machines of this series are designed to comply with insulation material class H according to EN 60034 for a permissible winding overtemperature of 125 K at an ambient temperature of up to 40° C. The insulation is resistant to the gases and vapours of flammable materials and meets the requirements that are made of materials that are damp-resistant and suitable for tropical conditions.

Special insulation is available at an extra charge, which is necessary in conditions in which there is concentrated acid vapour or metal dust or where the relative humidity is permanently above 80%. The insulation is also needed to provide protection from termites and mould.

When placing your order, you must state the following operating and ambient conditions:

- **Light load less than 60% of nominal load, for a relatively long period**
- **Temperature of cooling air less than 10° C**
- **Relative humidity less than 10% or greater than 80%**
- **If gases and vapours occur, such as chlorine, hydrogen sulphide, silicone or oil, for example, you must state the type and concentration.**

## Overload capacity

In accordance with EN 60034, the motors have a 1.5-fold current overload capacity for 45 seconds at the rated voltage and the rated excitation (note the reduced values with field weakening operation).

Motors for higher or longer peak loads or reduced motor moments of inertia are available on request.

**Controlled speed reduction**

You reduce the RPM speed by reducing the armature voltage.  
 The DC motors in this catalogue have a constant torque of up to 50 RPM downwards in the armature control range.

**Controlled speed increase**

Increasing the RPM speed is carried out by means of field weakening without losses starting from the basic RPM speed. In this connection, you can retain the list power for the basic RPM speed across the field weakening range assuming that the increase in the RPM speed does not exceed the value  $n_{\max \text{ elektrisch}}$ , which is stated in the list.  
 In the case of short-time duty or intermediate periodic loading, it is permissible to increase the power above the list power. In field weakening operation, there is a limited overload capacity.  
 Field weakening above  $n_{\max \text{ electrical}}$  is possible in many cases; however, it always results in a reduction in power.  
 In the case of extreme field control ranges, you must provide a compensating winding to limit the armature reaction.

**Excitation**

The exciter power losses in the list refer to separately excited machines without a stabilizing series winding.  
 In the case of switch off on the DC side, a free-wheeling diode or a parallel resistor must protect the field winding from closing overvoltages.  
 By preference, you should use the standard voltage of 310 V as the field voltage. In this case too it is possible to use different voltages; in particular, the 340 V output voltage that can be obtained from the bridge circuit with a 400-V feed.

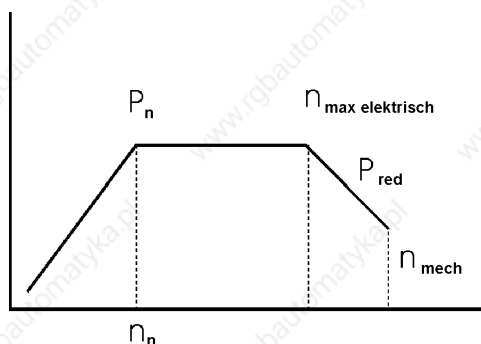

- $n_n$  Rated RPM speed
- $n_{\max \text{ electrical}}$  Max. field weakening RPM speed at  $P_n = \text{constant}$
- $n_{\text{mech}}$  Maximum permissible operating RPM speed
- $P_n$  Nominal power, constant in RPM speed range from  $n_n$  to  $n_{\max}$  or  $n_{\max \text{ electr}}$
- $P_{\text{red}}$  Reduced full-load power (safe commutation limit)

**Stabilizing series winding**

A stabilizing series winding can be fitted on request to stabilize the RPM speed.  
 All motors that are intended for tachometer control, as well as compensated motors are executed without a stabilizing series winding.

**Compensating winding**

For special requirements, e.g. impulse load operation, reversing operation and with a large field weakening range, it is possible to execute motors from size 180 onwards with a compensating winding.

Changes in RPM speed and output with a compensating winding:

Size	Speed	Reduction factor Torque	Output
180 to 280	0.94	0.93	0.874

## Type Selection

Converting list values to the desired RPM speed:

Normally, you start from the next highest RPM speed. You set the desired – lower – RPM speed by reducing the armature voltage on the armature voltage regulator. The torque remains constant with the output reducing with the RPM speed.

Starting from the next lowest RPM speed, you can set the desired – higher – RPM speed at constant output by field weakening (reducing the exciter current). This is an option with the field supply.

## Preferred Types

The motor types that are shown in the technical data with a grey background are preferred types.

The technical design of the preferred types is as follows:

- Fan at top, on B side, fan screw to right
- Rectangular filter to B side
- KLK on right, on B side, PGs according to dimensional drawing
- Tachometer generator GHT S 42 with 20V/1000 RPM
- Structural form IM B3
- Type of protection IP 23
- Ball bearings
- 2 thermal protectors (one in commutating pole and one in field for switch off)
- Insulation material class H
- Exciter voltage 310 V
- Paintwork RAL 7001, 9005, 6011, 7015 or primed (7032)



## Type Code

G N A 132 M N A56E 0 1 B T

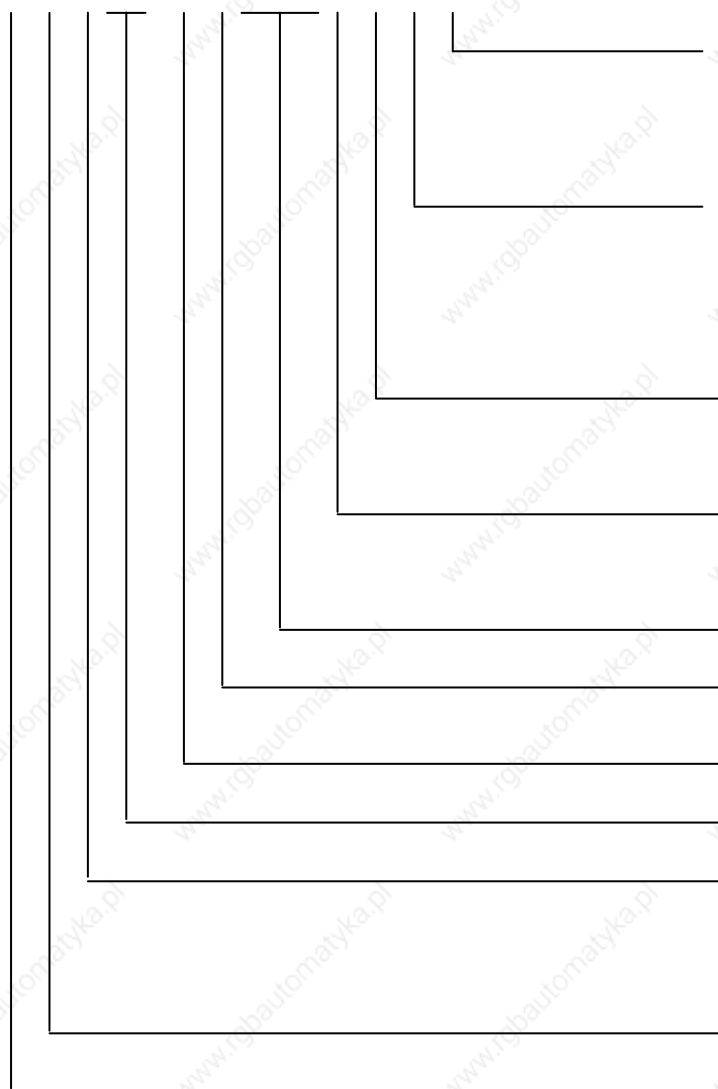

### Encoder

T Tachometer  
E Encoder – On request  
S Miscellaneous

### Encoder manufacturer

B Baumüller  
R Radio Energie – On request  
H Hübner – On request  
S Miscellaneous – On request

### Structural form

1 Pedestal version  
2 Pedestal flange version

### Brake

O No brake  
G Disk brake

### Armature circuit execution

### Standard execution

### Construction length

### Construction size, axle height

### Ventilation

A Mounted radial fan  
F force-ventilated via pipe – on request  
Q Heat exchanger

### Shunt

### Direct current

## Technical Data

### GNA 100 SN

Speed n Armature voltage U <sub>a</sub> of:				Out-put	Out-put	n max electr.	Arma- ture cur- rent:	Tor- que	Tor- que	Effectivity		Induc- tivity	Arma- ture circuit im- pedan- ce	Order Designation	
400 [V]	420 [V]	460 [V]	480 [V]	Pab [kW]	Pab [hp]	[min- 1]	I <sub>a</sub> [A]	M [Nm]	M [lbf ft]	eta A [%]	eta tot [%]	L <sub>a</sub> [mH]	R <sub>a</sub> [Ohm]		
3520  3720  4110  4300				10,8	14	4800	31	29,3	22	86,3	83,8	6,3	0,78	GNA 100 SN-	273O
				11,4	15	4800	31	29,3	22	86,7	84,4	6,3	0,78	GNA 100 SN-	273P
				12,6	17	4800	31	29,3	22	87,4	85,3	6,3	0,78	GNA 100 SN-	273R
				13,2	18	4800	31	29,3	22	87,8	85,7	6,3	0,78	GNA 100 SN-	273T
2820  2980  3300  3460				9	12	3700	27	30,5	22	84,3	81,5	9,2	1,17	GNA 100 SN-	27FO
				9,5	13	3700	27	30,5	22	84,8	82,2	9,2	1,17	GNA 100 SN-	27FP
				10,5	14	3700	27	30,5	22	85,7	83,3	9,2	1,17	GNA 100 SN-	27FR
				11	15	3700	27	30,5	22	86,1	83,8	9,2	1,17	GNA 100 SN-	27FT
2540  2690  2980  3130				8,2	11	3200	25	30,8	23	83,3	80,4	11,1	1,45	GNA 100 SN-	274O
				8,7	12	3200	25	30,8	23	83,9	81,1	11,1	1,45	GNA 100 SN-	274P
				9,6	13	3200	25	30,8	23	84,9	82,3	11,1	1,45	GNA 100 SN-	274R
				10,1	14	3200	25	30,8	23	85,4	82,9	11,1	1,45	GNA 100 SN-	274T
1970  2090  2320  2440				6,5	9	3000	20	31,5	23	80,8	77,4	19,2	2,23	GNA 100 SN-	275O
				6,9	9	3000	20	31,5	23	81,6	78,3	19,2	2,23	GNA 100 SN-	275P
				7,7	10	3000	20	31,5	23	82,8	79,7	19,2	2,23	GNA 100 SN-	275R
				8,1	11	3000	20	31,5	23	83,4	80,4	19,2	2,23	GNA 100 SN-	275T
1750  1860  2070  2180				5,9	8	2700	19	31,9	24	77,7	74,1	24,1	2,58	GNA 100 SN-	27IO
				6,2	8	2700	19	31,9	24	78,6	75,1	24,1	2,58	GNA 100 SN-	27IP
				6,9	9	2700	19	31,9	24	80	76,8	24,1	2,58	GNA 100 SN-	27IR
				7,3	10	2700	19	31,9	24	80,7	77,6	24,1	2,58	GNA 100 SN-	27IT
1530  1630  1820  1910				5,1	7	2300	17	31,8	23	76,1	72,2	30,8	3,15	GNA 100 SN-	276O
				5,4	7	2300	17	31,8	23	77,1	73,4	30,8	3,15	GNA 100 SN-	276P
				6,1	8	2300	17	31,8	23	78,7	75,2	30,8	3,15	GNA 100 SN-	276R
				6,4	9	2300	17	31,8	23	79,4	76	30,8	3,15	GNA 100 SN-	276T

Form Factor	< 1.03	Excitation Power	360 W	Operating Mode	S 1	Weight	55 kg
Mech. limit speed	7000 RPM	Excitation current at 310V	1.2 A	Type of protection	IP 23	Uncompensated	
Moment of inertia	0.017 kgm <sup>2</sup>	Insulation material class	H	Type of cooling	IC 06		

## DC Drives up to 500 kW

### GNA 100 MN

Speed n Armature voltage Ua of:				Out-put	Out-put	n max electr.	Arma- ture cur- rent:	Tor- que	Tor- que	Effectivity		Induc- tivity	Arma- ture circuit im- pedan- ce Ra	Order Designation	
400 [V]	420 [V]	460 [V]	480 [V]	Pab [kW]	Pab [hp]	[min- 1]	Ia [A]	M [Nm]	M [lbf ft]	eta A [%]	eta tot [%]	La [mH]	Ra [Ohm]		
2780  2930  3240  3400				10,8	14	4600	31	37,1	27	86,3	83,4	6,8	0,81	GNA 100 MN-	27DO
				11,4	15	4600	31	37,1	27	86,7	84	6,8	0,81	GNA 100 MN-	27DP
				12,6	17	4600	31	37,1	27	87,5	85	6,8	0,81	GNA 100 MN-	27DR
				13,2	18	4600	31	37,1	27	87,9	85,5	6,8	0,81	GNA 100 MN-	27DT
2450  2590  2860  3000				9,8	13	4100	27	38,2	28	85,1	82	8,6	0,98	GNA 100 MN-	273O
				10,4	14	4100	27	38,2	28	85,6	82,7	8,6	0,98	GNA 100 MN-	273P
				11,4	15	4100	27	38,2	28	86,5	83,8	8,6	0,98	GNA 100 MN-	273R
				12	16	4100	27	38,2	28	86,9	84,3	8,6	0,98	GNA 100 MN-	273T
1950  2060  2290  2400				8	11	3300	25	39	29	82,6	79	12,8	1,48	GNA 100 MN-	27FO
				8,4	11	3300	25	39	29	83,2	79,8	12,8	1,48	GNA 100 MN-	27FP
				9,3	12	3300	25	39	29	84,4	81,2	12,8	1,48	GNA 100 MN-	27FR
				9,8	13	3300	25	39	29	84,8	81,8	12,8	1,48	GNA 100 MN-	27FT
1600  1700  1890  1990				6,6	9	2800	20	39,4	29	79,6	75,7	17,9	2,12	GNA 100 MN-	27GO
				7	9	2800	20	39,4	29	80,4	76,7	17,9	2,12	GNA 100 MN-	27GP
				7,8	10	2800	20	39,4	29	81,8	78,3	17,9	2,12	GNA 100 MN-	27GR
				8,2	11	2800	20	39,4	29	82,4	79	17,9	2,12	GNA 100 MN-	27GT
1280  1360  1520  1600				5,3	7	2300	19	39,2	29	76,7	72,1	23,8	2,8	GNA 100 MN-	275O
				5,6	8	2300	19	39,2	29	77,6	73,2	23,8	2,8	GNA 100 MN-	275P
				6,2	8	2300	19	39,2	29	79,2	75,1	23,8	2,8	GNA 100 MN-	275R
				6,6	9	2300	19	39,2	29	80	76	23,8	2,8	GNA 100 MN-	275T

Form Factor	< 1.03	Excitation Power	430 W	Operating Mode	S 1	Weight	73 kg
Mech. limit speed	7000 RPM	Excitation current at 310V	1.4 A	Type of protection	IP 23	Uncompensated	
Moment of inertia	0.022 kgm <sup>2</sup>	Insulation material class	H	Type of cooling	IC 06		

**GNA 100 LN**

Speed n Armature voltage Ua of:				Out-put	Out-put	n max electr.	Arma- ture cur- rent:	Tor- que	Tor- que	Effectivity		Induc- tivity	Arma- ture circuit im- pedan- ce Ra	Order Designation
400 [V]	420 [V]	460 [V]	480 [V]	Pab [kW]	Pab [hp]	[min- 1]	Ia [A]	M [Nm]	M [lbf ft]	eta A [%]	eta tot [%]	La [mH]	Ra [Ohm]	
2930				13,2	18	4500	38	43	32	88	85,2	4,8	0,53	GNA 100 LN- 272O
3090				13,9	19	4500	38	43	32	88,4	85,7	4,8	0,53	GNA 100 LN- 272P
3410				15,4	21	4500	37	43	32	89,1	86,6	4,8	0,53	GNA 100 LN- 272R
3570				16,1	22	4500	37	43	32	89,4	87	4,8	0,53	GNA 100 LN- 272T
2470				11,7	16	4200	34	45,3	33	86,7	83,6	6,6	0,75	GNA 100 LN- 27CO
2610				12,4	17	4200	34	45,3	33	87,2	84,2	6,6	0,75	GNA 100 LN- 27CP
2880				13,6	18	4200	34	45,3	33	88	85,2	6,6	0,75	GNA 100 LN- 27CR
3020				14,3	19	4200	34	45,3	33	88,3	85,7	6,6	0,75	GNA 100 LN- 27CT
2130				10,3	14	3900	30	46,2	34	85,5	82,1	8,5	0,97	GNA 100 LN- 27DO
2250				10,9	15	3900	30	46,2	34	86,1	82,8	8,5	0,97	GNA 100 LN- 27DP
2490				12	16	3900	30	46,2	34	87	84	8,5	0,97	GNA 100 LN- 27DR
2610				12,6	17	3900	30	46,2	34	87,4	84,5	8,5	0,97	GNA 100 LN- 27DT
1870				9,2	12	3300	27	47	35	84,3	80,6	10,9	1,17	GNA 100 LN- 273O
1980				9,7	13	3300	27	47	35	84,9	81,3	10,9	1,17	GNA 100 LN- 273P
2190				10,8	14	3300	27	47	35	85,9	82,6	10,9	1,17	GNA 100 LN- 273R
2300				11,3	15	3300	27	47	35	86,4	83,2	10,9	1,17	GNA 100 LN- 273T
1340				6,6	9	2500	21	46,7	34	79,4	74,9	15,6	2,17	GNA 100 LN- 274O
1420				6,9	9	2500	21	46,7	34	80,2	75,8	15,6	2,17	GNA 100 LN- 274P
1580				7,7	10	2500	21	46,7	34	81,6	77,5	15,6	2,17	GNA 100 LN- 274R
1660				8,1	11	2500	21	46,7	34	82,3	78,3	15,6	2,17	GNA 100 LN- 274T

Form Factor	< 1.03	Excitation Power	500 W	Operating Mode	S 1	Weight	93 kg
Mech. limit speed	6000 RPM	Excitation current at 310V	1.6 A	Type of protection	IP 23	Uncompensated	
Moment of inertia	0.027 kgm <sup>2</sup>	Insulation material class	H	Type of cooling	IC 06		

GNA 112 SN

Speed n Armature voltage Ua of:				Out-put	Out-put	n max electr.	Arma- ture cur- rent:	Tor- que	Tor- que	Effectivity		Induc- tivity	Arma- ture circuit im- pedan- ce	Order Designation	
400 [V]	420 [V]	460 [V]	480 [V]	Pab [kW]	Pab [hp]	[min- 1]	Ia [A]	M [Nm]	M [lbf ft]	eta A [%]	eta tot [%]	La [mH]	Ra [Ohm]		
3100  3270  3610  3770				22	30	4500	62	67,8	50	89,3	87,3	5,2	0,32	GNA 112 SN-	4720
				23,2	31	4500	62	67,8	50	89,6	87,7	5,2	0,32	GNA 112 SN-	472P
				25,6	34	4500	62	67,8	50	90,3	88,5	5,2	0,32	GNA 112 SN-	472R
				26,8	36	4500	62	67,8	50	90,5	88,8	5,2	0,32	GNA 112 SN-	472T
2620  2760  3050  3200				18,5	25	3900	52	67,4	50	88,3	86	7,1	0,43	GNA 112 SN-	47CO
				19,5	26	3900	52	67,4	50	88,7	86,5	7,1	0,43	GNA 112 SN-	47CP
				21,5	29	3900	52	67,4	50	89,4	87,4	7,1	0,43	GNA 112 SN-	47CR
				22,6	30	3900	52	67,4	50	89,7	87,8	7,1	0,43	GNA 112 SN-	47CT
2250  2380  2630  2750				15,9	21	2900	46	67,5	50	86,6	84	9,2	0,58	GNA 112 SN-	47DO
				16,8	23	2900	46	67,5	50	87,1	84,7	9,2	0,58	GNA 112 SN-	47DP
				18,6	25	2900	46	67,5	50	88	85,7	9,2	0,58	GNA 112 SN-	47DR
				19,4	26	2900	46	67,5	50	88,3	86,1	9,2	0,58	GNA 112 SN-	47DT
1970  2080  2310  2420				13,9	19	2900	41	67,4	50	85,6	82,7	11,7	0,75	GNA 112 SN-	4730
				14,7	20	2900	41	67,4	50	86,1	83,4	11,7	0,75	GNA 112 SN-	473P
				16,3	22	2900	41	67,4	50	87,1	84,6	11,7	0,75	GNA 112 SN-	473R
				17,1	23	2900	41	67,4	50	87,5	85,1	11,7	0,75	GNA 112 SN-	473T
1420  1500  1670  1760				10,2	14	2600	31	68,6	51	82,5	78,9	20,7	1,32	GNA 112 SN-	4740
				10,8	14	2600	31	68,6	51	83,2	79,8	20,7	1,32	GNA 112 SN-	474P
				12	16	2600	31	68,6	51	84,5	81,2	20,7	1,32	GNA 112 SN-	474R
				12,6	17	2600	31	68,6	51	85	81,9	20,7	1,32	GNA 112 SN-	474T
1090  1160  1290  1360				7,8	10	2000	25	68,3	50	79,3	75	32,2	2,03	GNA 112 SN-	4750
				8,3	11	2000	25	68,3	50	80,2	76,1	32,2	2,03	GNA 112 SN-	475P
				9,2	12	2000	25	68,3	50	81,6	77,8	32,2	2,03	GNA 112 SN-	475R
				9,7	13	2000	25	68,3	50	82,3	78,6	32,2	2,03	GNA 112 SN-	475T

Form Factor	< 1.03	Excitation Power	560 W	Operating Mode	S 1	Weight	100 kg
Mech. limit speed	6700 RPM	Excitation current at 310V	1.8 A	Type of protection	IP 23	Uncompensated	
Moment of inertia	0.05 kgm <sup>2</sup>	Insulation material class	H	Type of cooling	IC 06		

**GNA 112 MN**

Speed n Armature voltage Ua of:				Out-put	Out-put	n max electr.	Arma- ture cur- rent:	Tor- que	Tor- que	Effectivity		Induc- tivity	Arma- ture circuit im- pedan- ce Ra	Order Designation	
400 [V]	420 [V]	460 [V]	480 [V]	Pab [kW]	Pab [hp]	[min- 1]	Ia [A]	M [Nm]	M [lbf ft]	eta A [%]	eta tot [%]	La [mH]			
2970				23,9	32	4300	67	76,9	57	88,9	86,9	4,5	0,25	GNA 112 MN-	47BO
3130				25,2	34	4300	67	76,9	57	89,3	87,3	4,5	0,25	GNA 112 MN-	47BP
3450				27,8	37	4300	67	76,9	57	89,9	88,1	4,5	0,25	GNA 112 MN-	47BR
3610				29,1	39	4300	67	76,9	57	90,2	88,5	4,5	0,25	GNA 112 MN-	47BT
2430				20	27	4200	57	78,6	58	87,6	85,2	6,6	0,4	GNA 112 MN-	472O
2560				21,1	28	4200	57	78,6	58	88	85,7	6,6	0,4	GNA 112 MN-	472P
2830				23,3	31	4200	57	78,6	58	88,8	86,7	6,6	0,4	GNA 112 MN-	472R
2970				24,5	33	4200	57	78,6	58	89,1	87,1	6,6	0,4	GNA 112 MN-	472T
2050				17,5	23	3600	50	81,5	60	87,1	84,4	9	0,52	GNA 112 MN-	47CO
2160				18,4	25	3600	50	81,5	60	87,5	85	9	0,52	GNA 112 MN-	47CP
2390				20,4	27	3600	50	81,5	60	88,4	86	9	0,52	GNA 112 MN-	47CR
2510				21,4	29	3600	50	81,5	60	88,8	86,5	9	0,52	GNA 112 MN-	47CT
1550				13,2	18	3000	39	81,3	60	84,2	80,9	14,8	0,86	GNA 112 MN-	473O
1640				14	19	3000	39	81,3	60	84,8	81,7	14,8	0,86	GNA 112 MN-	473P
1820				15,5	21	3000	39	81,3	60	85,9	83	14,8	0,86	GNA 112 MN-	473R
1910				16,3	22	3000	39	81,3	60	86,4	83,6	14,8	0,86	GNA 112 MN-	473T

Form Factor	< 1.03	Excitation Power	650 W	Operating Mode	S 1	Weight	122 kg
Mech. limit speed	6700 RPM	Excitation current at 310V	2.1 A	Type of protection	IP 23	Uncompensated	
Moment of inertia	0.06 kgm <sup>2</sup>	Insulation material class	H	Type of cooling	IC 06		

## DC Drives up to 500 kW

### GNA 112 LN

Speed n Armature voltage Ua of:				Out-put	Out-put	n max electr.	Arma- ture cur- rent:	Tor- que	Tor- que	Effectivity		Induc- tivity	Arma- ture circuit im- pedan- ce Ra	Order Designation	
400 [V]	420 [V]	460 [V]	480 [V]	Pab [kW]	Pab [hp]	[min- 1]	Ia [A]	M [Nm]	M [lbf ft]	eta A [%]	eta tot [%]	La [mH]			
3040  3200  3530  3690				28	38	4800	79	87,9	65	88,7	86,7	3,7	0,21	GNA 112 LN-	47AO
				29,5	40	4800	79	87,9	65	89	87,2	3,7	0,21	GNA 112 LN-	47AP
				32,5	44	4800	79	87,9	65	89,7	88	3,7	0,21	GNA 112 LN-	47AR
				34	46	4800	79	87,9	65	90	88,3	3,7	0,21	GNA 112 LN-	47AT
2400  2530  2790  2920				23,5	32	4200	66	93,5	69	88,4	86,1	5,7	0,29	GNA 112 LN-	47BO
				24,8	33	4200	66	93,5	69	88,8	86,7	5,7	0,29	GNA 112 LN-	47BP
				27,3	37	4200	66	93,5	69	89,5	87,5	5,7	0,29	GNA 112 LN-	47BR
				28,6	38	4200	66	93,5	69	89,9	87,9	5,7	0,29	GNA 112 LN-	47BT
1950  2060  2280  2390				19,3	26	3800	56	94,5	70	86,4	83,8	8,2	0,46	GNA 112 LN-	472O
				20,4	27	3800	56	94,5	70	86,9	84,4	8,2	0,46	GNA 112 LN-	472P
				22,6	30	3800	56	94,5	70	87,8	85,5	8,2	0,46	GNA 112 LN-	472R
				23,7	32	3800	56	94,5	70	88,2	86	8,2	0,46	GNA 112 LN-	472T
1240  1310  1460  1530				12,4	17	2600	37	95,5	70	83	79,3	18,6	1	GNA 112 LN-	473O
				13,1	18	2600	37	95,5	70	83,7	80,1	18,6	1	GNA 112 LN-	473P
				14,6	20	2600	37	95,5	70	84,9	81,6	18,6	1	GNA 112 LN-	473R
				15,3	21	2600	37	95,5	70	85,4	82,2	18,6	1	GNA 112 LN-	473T

Form Factor	< 1.03	Excitation Power	700 W	Operating Mode	S 1	Weight	152 kg
Mech. limit speed	5300 RPM	Excitation current at 310V	2.3 A	Type of protection	IP 23	Uncompensated	
Moment of inertia	0.08 kgm <sup>2</sup>	Insulation material class	H	Type of cooling	IC 06		

## GNA 132 KN

Speed n Armature voltage Ua of:				Out-put	Out-put	n max electr.	Arma- ture cur- rent:	Tor- que	Tor- que	Effectivity		Induc- tivity	Arma- ture circuit im- pedan- ce	Order Designation	
400 [V]	420 [V]	460 [V]	480 [V]	Pab [kW]	Pab [hp]	[min- 1]	Ia [A]	M [Nm]	M [lbf ft]	eta A [%]	eta tot [%]	La [mH]	Ra [Ohm]		
2950	3110	3440	3600	23	31	4500	67	74,5	55	86,5	83,8	5,2	0,3	GNA 132 KN-	272O
				24,3	33	4500	66	74,5	55	86,9	84,3	5,2	0,3	GNA 132 KN-	272P
				26,8	36	4500	66	74,5	55	87,7	85,3	5,2	0,3	GNA 132 KN-	272R
				28,1	38	4500	66	74,5	55	88,1	85,7	5,2	0,3	GNA 132 KN-	272T
2500	2640	2920	3050	20,5	27	4000	59	78,3	58	86,9	83,8	7,1	0,39	GNA 132 KN-	27CO
				21,6	29	4000	59	78,3	58	87,3	84,4	7,1	0,39	GNA 132 KN-	27CP
				23,9	32	4000	59	78,3	58	88,2	85,4	7,1	0,39	GNA 132 KN-	27CR
				25	34	4000	59	78,3	58	88,5	85,9	7,1	0,39	GNA 132 KN-	27CT
2110	2230	2470	2590	18,2	24	3600	53	82,3	61	85,8	82,4	9,5	0,53	GNA 132 KN-	473O
				19,2	26	3600	53	82,3	61	86,3	83,1	9,5	0,53	GNA 132 KN-	473P
				21,3	29	3600	53	82,3	61	87,2	84,3	9,5	0,53	GNA 132 KN-	473R
				22,3	30	3600	53	82,3	61	87,6	84,8	9,5	0,53	GNA 132 KN-	473T
1520	1610	1790	1880	13,5	18	2900	41	84,8	63	82,7	78,6	16,6	0,9	GNA 132 KN-	474O
				14,3	19	2900	41	84,8	63	83,4	79,4	16,6	0,9	GNA 132 KN-	474P
				15,9	21	2900	41	84,8	63	84,6	80,9	16,6	0,9	GNA 132 KN-	474R
				16,7	22	2900	41	84,8	63	85,1	81,6	16,6	0,9	GNA 132 KN-	474T
1160	1230	1370	1450	10,3	14	2100	33	84,8	63	78,3	73,5	25,9	1,45	GNA 132 KN-	475O
				10,9	15	2100	33	84,8	63	79,2	74,5	25,9	1,45	GNA 132 KN-	475P
				12,2	16	2100	33	84,8	63	80,7	76,3	25,9	1,45	GNA 132 KN-	475R
				12,9	17	2100	33	84,8	63	81,4	77,2	25,9	1,45	GNA 132 KN-	475T

Form Factor	< 1.03	Excitation Power	750 W	Operating Mode	S 1	Weight	125 kg
Mech. limit speed	5300 RPM	Excitation current at 310V	2.4 A	Type of protection	IP 23	Uncompensated	
Moment of inertia	0.07 kgm <sup>2</sup>	Insulation material class	H	Type of cooling	IC 06		



GNA 132 SN

Speed n Armature voltage Ua of:				Out-put	Out-put	n max electr.	Arma- ture cur- rent:	Tor- que	Tor- que	Effectivity		Induc- tivity	Arma- ture circuit im- pedan- ce	Order Designation	
400 [V]	420 [V]	460 [V]	480 [V]	Pab [kW]	Pab [hp]	[min- 1]	Ia [A]	M [Nm]	M [lbf ft]	eta A [%]	eta tot [%]	La [mH]	Ra [Ohm]		
2910				34,5	46	4500	97	113	83	88,8	86,6	3,9	0,19	GNA 132 SN-	47BO
3070				36,4	49	4500	97	113	83	89,2	87,1	3,9	0,19	GNA 132 SN-	47BP
3380				40,1	54	4500	97	113	83	89,9	87,9	3,9	0,19	GNA 132 SN-	47BR
3540				42	56	4500	97	113	83	90,1	88,3	3,9	0,19	GNA 132 SN-	47BT
2390				29	39	4000	82	116	86	88,1	85,5	5,7	0,28	GNA 132 SN-	472O
2520				30,6	41	4000	82	116	86	88,5	86	5,7	0,28	GNA 132 SN-	472P
2790				33,8	45	4000	82	116	86	89,3	87	5,7	0,28	GNA 132 SN-	472R
2920				35,4	47	4000	82	116	86	89,6	87,4	5,7	0,28	GNA 132 SN-	472T
2130				26,5	36	3600	76	119	88	87,2	84,4	7	0,34	GNA 132 SN-	272O
2250				28	38	3600	76	119	88	87,7	85	7	0,34	GNA 132 SN-	272P
2490				31	42	3600	76	119	88	88,5	86	7	0,34	GNA 132 SN-	272R
2600				32,3	43	3600	76	119	88	88,8	86,5	7	0,34	GNA 132 SN-	272T
1520				19	25	2900	56	119	88	85	81,3	12,8	0,63	GNA 132 SN-	473O
1610				20,1	27	2900	56	119	88	85,6	82,1	12,8	0,63	GNA 132 SN-	473P
1780				22,3	30	2900	56	119	88	86,6	83,4	12,8	0,63	GNA 132 SN-	473R
1870				23,4	31	2900	56	119	88	87,1	84	12,8	0,63	GNA 132 SN-	473T
1090				13,8	19	2100	42	121	89	81,4	76,8	22,5	1,06	GNA 132 SN-	474O
1160				14,7	20	2100	42	121	89	82,2	77,8	22,5	1,06	GNA 132 SN-	474P
1290				16,3	22	2100	42	121	89	83,5	79,5	22,5	1,06	GNA 132 SN-	474R
1350				17,1	23	2100	42	121	89	84,1	80,2	22,5	1,06	GNA 132 SN-	474T

Form Factor	< 1.03	Excitation Power	1000 W	Operating Mode	S 1	Weight	160 kg
Mech. limit speed	5300 RPM	Excitation current at 310V	3.2 A	Type of protection	IP 23	Uncompensated	
Moment of inertia	0.09 kgm <sup>2</sup>	Insulation material class	H	Type of cooling	IC 06		

GNA 132 MN

Speed n Armature voltage Ua of:				Out-put	Out-put	n max electr.	Arma- ture cur- rent:	Tor- que	Tor- que	Effectivity		Induc- tivity	Arma- ture circuit im- pedan- ce Ra	Order Designation	
400 [V]	420 [V]	460 [V]	480 [V]	Pab [kW]	Pab [hp]	[min- 1]	Ia [A]	M [Nm]	M [lbf ft]	eta A [%]	eta tot [%]	La [mH]	[Ohm]		
3170	3340	3680	3850	50	67	4500	139	151	111	89,9	88	2,5	0,11	GNA 132 MN-	2710
				52,7	71	4500	139	151	111	90,3	88,4	2,5	0,11	GNA 132 MN-	271P
				58	78	4500	139	151	111	90,8	89,2	2,5	0,11	GNA 132 MN-	271R
				60,7	81	4500	139	151	111	91,1	89,5	2,5	0,11	GNA 132 MN-	271T
2600	2740	3020	3160	42,5	57	4300	119	156	115	89,5	87,3	3,6	0,16	GNA 132 MN-	47AO
				44,8	60	4300	119	156	115	89,8	87,7	3,6	0,16	GNA 132 MN-	47AP
				49,4	66	4300	119	156	115	90,5	88,5	3,6	0,16	GNA 132 MN-	47AR
				51,6	69	4300	119	156	115	90,8	88,9	3,6	0,16	GNA 132 MN-	47AT
2040	2150	2380	2490	35	47	3400	99	164	121	88	85,5	5,6	0,24	GNA 132 MN-	47BO
				36,9	49	3400	99	164	121	88,5	86	5,6	0,24	GNA 132 MN-	47BP
				40,8	55	3400	99	164	121	89,3	87	5,6	0,24	GNA 132 MN-	47BR
				42,7	57	3400	99	164	121	89,6	87,4	5,6	0,24	GNA 132 MN-	47BT
1490	1580	1750	1830	26	35	2800	76	167	123	86,1	82,8	9,9	0,44	GNA 132 MN-	272O
				27,6	37	2800	76	167	123	86,7	83,5	9,9	0,44	GNA 132 MN-	272P
				30,5	41	2800	76	167	123	87,7	84,7	9,9	0,44	GNA 132 MN-	272R
				31,9	43	2800	76	167	123	88,1	85,2	9,9	0,44	GNA 132 MN-	272T
1050	1110	1240	1300	18	24	1900	55	164	121	82,1	77,9	18	0,75	GNA 132 MN-	473O
				19	25	1900	55	164	121	82,8	78,7	18	0,75	GNA 132 MN-	473P
				21,3	29	1900	55	164	121	84,2	80,4	18	0,75	GNA 132 MN-	473R
				22,3	30	1900	55	164	121	84,8	81,1	18	0,75	GNA 132 MN-	473T

Form Factor	< 1.03	Excitation Power	1200 W	Operating Mode	S 1	Weight	185 kg
Mech. limit speed	5300 RPM	Excitation current at 310V	3.9 A	Type of protection	IP 23	Uncompensated	
Moment of inertia	0.12 kgm <sup>2</sup>	Insulation material class	H	Type of cooling	IC 06		

GNA 132 LN

Speed n Armature voltage Ua of:				Out-put	Out-put	n max electr.	Arma- ture cur- rent:	Tor- que	Tor- que	Effectivity		Induc- tivity	Arma- ture circuit im- pedan- ce	Order Designation	
400 [V]	420 [V]	460 [V]	480 [V]	Pab [kW]	Pab [hp]	[min- 1]	Ia [A]	M [Nm]	M [lbf ft]	eta A [%]	eta tot [%]	La [mH]	Ra [Ohm]		
2660				51	68	4000	143	183	135	89,2	87,1	2,7	0,11	GNA 132 LN-	471O
2800				53,7	72	4000	143	183	135	89,6	87,5	2,7	0,11	GNA 132 LN-	471P
3090				59,3	80	4000	143	183	135	90,2	88,3	2,7	0,11	GNA 132 LN-	471R
3230				61,9	83	4000	143	183	135	90,5	88,7	2,7	0,11	GNA 132 LN-	471T
1950				40	54	3500	114	196	145	88	85,4	4,8	0,19	GNA 132 LN-	47AO
2060				42,3	57	3500	114	196	145	88,5	85,9	4,8	0,19	GNA 132 LN-	47AP
2270				46,6	62	3500	114	196	145	89,2	86,9	4,8	0,19	GNA 132 LN-	47AR
2380				48,8	65	3500	114	196	145	89,6	87,4	4,8	0,19	GNA 132 LN-	47AT
1530				32,5	44	2800	94	203	150	86,9	83,7	7,5	0,29	GNA 132 LN-	47BO
1620				34,4	46	2800	94	203	150	87,4	84,4	7,5	0,29	GNA 132 LN-	47BP
1790				38	51	2800	94	203	150	88,3	85,5	7,5	0,29	GNA 132 LN-	47BR
1870				39,7	53	2800	93	203	150	88,7	86	7,5	0,29	GNA 132 LN-	47BT
1240				26,8	36	2400	79	206	152	85,1	81,5	11	0,44	GNA 132 LN-	472O
1310				28,3	38	2400	79	206	152	85,7	82,2	11	0,44	GNA 132 LN-	472P
1450				31,3	42	2400	79	206	152	86,8	83,6	11	0,44	GNA 132 LN-	472R
1530				33,1	44	2400	79	206	152	87,3	84,2	11	0,44	GNA 132 LN-	472T

Form Factor	< 1.03	Excitation Power	1300 W	Operating Mode	S 1	Weight 250 kg Uncompensated
Mech. limit speed	4000 RPM	Excitation current at 310V	4.0 A	Type of protection	IP 23	
Moment of inertia	0.16 kgm <sup>2</sup>	Insulation material class	H	Type of cooling	IC 06	

**GNA 160 SN**

Speed n Armature voltage Ua of:				Out-put	Out-put	n max electr.	Arma- ture cur- rent:	Tor- que	Tor- que	Effectivity		Induc- tivity	Arma- ture circuit im- pedan- ce	Order Designation	
400 [V]	420 [V]	460 [V]	480 [V]	Pab [kW]	Pab [hp]	[min- 1]	Ia [A]	M [Nm]	M [lbf ft]	eta A [%]	eta tot [%]	La [mH]	Ra [Ohm]		
3070	3230	3560	3720	81	109	4300	223	252	186	90,6	88,7	1,4	0,052	GNA 160 SN-	471O
				85,2	114	4300	223	252	186	90,9	89,1	1,4	0,052	GNA 160 SN-	471P
				94	126	4300	223	252	186	91,5	89,8	1,4	0,052	GNA 160 SN-	471R
				98	131	4300	223	252	186	91,7	90,1	1,4	0,052	GNA 160 SN-	471T
2750	2900	3190	3340	75	101	4100	207	261	193	90,8	88,7	1,8	0,065	GNA 160 SN-	271O
				79,1	106	4100	206	261	193	91,1	89,2	1,8	0,065	GNA 160 SN-	271P
				87	117	4100	206	261	193	91,7	89,9	1,8	0,065	GNA 160 SN-	271R
				91,1	122	4100	206	261	193	91,9	90,2	1,8	0,065	GNA 160 SN-	271T
2260	2380	2630	2750	64	86	3900	179	271	200	89,6	87,3	2,6	0,091	GNA 160 SN-	47AO
				67,4	90	3900	178	271	200	90	87,8	2,6	0,091	GNA 160 SN-	47AP
				74,5	100	3900	178	271	200	90,7	88,6	2,6	0,091	GNA 160 SN-	47AR
				77,9	104	3900	178	271	200	91	89	2,6	0,091	GNA 160 SN-	47AT
1780	1880	2070	2170	53	71	3200	149	284	209	88,9	86,1	4	0,144	GNA 160 SN-	47BO
				56	75	3200	149	284	209	89,4	86,7	4	0,144	GNA 160 SN-	47BP
				61,6	83	3200	149	284	209	90,1	87,6	4	0,144	GNA 160 SN-	47BR
				64,6	87	3200	149	284	209	90,4	88,1	4	0,144	GNA 160 SN-	47BT
1300	1370	1520	1590	38	51	2600	110	279	206	86,4	82,8	7	0,246	GNA 160 SN-	272O
				40	54	2600	110	279	206	86,9	83,4	7	0,246	GNA 160 SN-	272P
				44,4	60	2600	110	279	206	87,9	84,7	7	0,246	GNA 160 SN-	272R
				46,5	62	2600	110	279	206	88,3	85,2	7	0,246	GNA 160 SN-	272T

Form Factor	< 1.03	Excitation Power	1920 W	Operating Mode	S 1	Weight	240 kg
Mech. limit speed	4500 RPM	Excitation current at 310V	6.2 A	Type of protection	IP 23	Uncompensated	
Moment of inertia	0.24 kgm <sup>2</sup>	Insulation material class	H	Type of cooling	IC 06		

## DC Drives up to 500 kW

### GNA 160 MN

Speed n Armature voltage Ua of:				Out-put	Out-put	n max	Arma- ture cur- rent:	Tor- que	Tor- que	Effectivity		Induc- tivity	Armature circuit imped- ance	Order Designation
400	420	460	480	Pab	Pab	electr.	la	M	M	eta A	eta tot	La	Ra	
[V]	[V]	[V]	[V]	[kW]	[hp]	[min- 1]	[A]	[Nm]	[lbf ft]	[%]	[%]	[mH]	[Ohm]	
2590	2730	3000	3140	100	134	3200	270	369	272	92,4	90,7	1,5	0,045	GNA 160 MN- Y7AO
				105	141	3500	270	369	272	92,7	91	1,5	0,045	GNA 160 MN- Y7AP
				116	156	3800	270	369	272	93,2	91,6	1,5	0,045	GNA 160 MN- Y7AR
				121	162	3800	270	369	272	93,4	91,9	1,5	0,045	GNA 160 MN- Y7AT
2120	2230	2460	2580	84	113	3900	233	378	279	90,3	88,3	2,1	0,068	GNA 160 MN- 471O
				88,4	119	3900	232	378	279	90,7	88,8	2,1	0,068	GNA 160 MN- 471P
				97,5	131	3900	232	378	279	91,3	89,6	2,1	0,068	GNA 160 MN- 471R
				102	137	3900	232	378	279	91,6	89,6	2,1	0,068	GNA 160 MN- 471T
1680	1770	1950	2050	69	93	3000	193	392	289	89,6	87,2	3,3	0,1	GNA 160 MN- Y72O
				72,7	97	3000	192	392	289	90	87,7	3,3	0,1	GNA 160 MN- Y72P
				80,1	107	3000	192	392	289	90,7	88,6	3,3	0,1	GNA 160 MN- Y72R
				84,2	113	3000	192	392	289	91	89	3,3	0,1	GNA 160 MN- Y72T
1220	1290	1420	1490	50	67	2400	143	391	288	87,4	84,3	5,9	0,19	GNA 160 MN- 47BO
				52,9	71	2400	143	391	288	87,9	85	5,9	0,19	GNA 160 MN- 47BP
				58,2	78	2400	143	391	288	88,8	86,1	5,9	0,19	GNA 160 MN- 47BR
				61,1	82	2400	143	391	288	89,2	86,6	5,9	0,19	GNA 160 MN- 47BT
880	930	1030	1080	37,5	50	1800	110	407	300	85	81,2	10,4	0,32	GNA 160 MN- 272O
				39,6	53	1800	110	407	300	85,7	82	10,4	0,32	GNA 160 MN- 272P
				43,9	59	1800	110	407	300	86,8	83,4	10,4	0,32	GNA 160 MN- 272R
				46	62	1800	110	407	300	87,3	84	10,4	0,32	GNA 160 MN- 272T

Form Factor	< 1.03	Excitation Power	2100 W	Operating Mode	S 1	Weight 320 kg Uncompensated
Mech. limit speed	4500 RPM	Excitation current at 310V	6.7 A	Type of protection	IP 23	
Moment of inertia	0.35 kgm <sup>2</sup>	Insulation material class	H	Type of cooling	IC 06	

**GNA 160 LN**

Speed n Armature voltage Ua of:				Out-put	Out-put	n max electr.	Arma- ture cur- rent:	Tor- que	Tor- que	Effectivity		Induc- tivity	Arma- ture circuit im- pedan- ce	Order Designation	
400 [V]	420 [V]	460 [V]	480 [V]	Pab [kW]	Pab [hp]	[min- 1]	Ia [A]	M [Nm]	M [lbf ft]	eta A [%]	eta tot [%]	La [mH]	Ra [Ohm]		
2730				122	164	3300	334	427	315	91,5	89,6	1,1	0,033	GNA 160 LN-	Y71O
2870				128	172	3300	333	427	315	91,7	90	1,1	0,033	GNA 160 LN-	Y71P
3160				141	189	3300	333	427	315	92,3	90,7	1,1	0,033	GNA 160 LN-	Y71R
2500				112	150	3300	306	428	316	91,5	89,5	1,3	0,038	GNA 160 LN-	W71O
2630				118	158	3300	306	428	316	91,8	89,9	1,3	0,038	GNA 160 LN-	W71P
2900				130	174	3300	305	428	316	92,3	90,6	1,3	0,038	GNA 160 LN-	W71R
3030				136	182	3300	305	428	316	92,6	90,9	1,3	0,038	GNA 160 LN-	W71T
2020				95	127	2500	260	449	331	91,4	89,1	2	0,056	GNA 160 LN-	Y7AO
2130				100	134	2700	260	449	331	91,7	89,5	2	0,056	GNA 160 LN-	Y7AP
2340				110	148	2900	259	449	331	92,3	90,2	2	0,056	GNA 160 LN-	Y7AR
2450				115	154	3000	259	449	331	92,5	90,6	2	0,056	GNA 160 LN-	Y7AT
1650				80	107	3000	224	463	341	89,5	86,9	2,8	0,084	GNA 160 LN-	471O
1740				84,4	113	3000	223	463	341	89,9	87,4	2,8	0,084	GNA 160 LN-	471P
1920				93,1	125	3000	223	463	341	90,6	88,3	2,8	0,084	GNA 160 LN-	471R
2010				97,5	131	3000	223	463	341	90,9	88,7	2,8	0,084	GNA 160 LN-	471T
1080				53	71	2100	152	469	346	87,2	83,5	6,2	0,183	GNA 160 LN-	27AO
1140				55,9	75	2100	152	469	346	87,7	84,1	6,2	0,183	GNA 160 LN-	27AP
1260				61,8	83	2100	152	469	346	88,6	85,3	6,2	0,183	GNA 160 LN-	27AR
1320				64,8	87	2100	152	469	346	89	85,9	6,2	0,183	GNA 160 LN-	27AT

Form Factor	< 1.03	Excitation Power	2200 W	Operating Mode	S 1	Weight	410 kg
Mech. limit speed	3300 RPM	Excitation current at 310V	6.9 A	Type of protection	IP 23	Uncompensated	
Moment of inertia	0.45 kgm <sup>2</sup>	Insulation material class	H	Type of cooling	IC 06		

## DC Drives up to 500 kW

### GNA 180 SN

Speed n Armature voltage Ua of:				Out-put	Out-put	n max electr.	Arma- ture cur- rent:	Tor- que	Tor- que	Effectivity		Induc- tivity	Arma- ture circuit im- pedan- ce Ra	Order Designation	
400 [V]	420 [V]	460 [V]	480 [V]	Pab [kW]	Pab [hp]	[min- 1]	Ia [A]	M [Nm]	M [lbf ft]	eta A [%]	eta tot [%]	La [mH]	[Ohm]		
2950	3110	3420	3570	138	185	4000	375	447	330	92,1	90,8	0,9	0,029	GNA 180 SN-	S71O
				146	196	4000	375	447	330	92,4	91,1	0,9	0,029	GNA 180 SN-	S71P
				160	215	4000	375	447	330	92,9	91,7	0,9	0,029	GNA 180 SN-	S71R
				167	224	4000	374	447	330	93,1	91,9	0,9	0,029	GNA 180 SN-	S71T
1	2400	2650		110	148	4000	302	461	340	91,1	89,4	1,4	0,052	GNA 180 SN-	471O
				116	156	4000	302	461	340	91,4	89,8	1,4	0,052	GNA 180 SN-	471P
				128	172	4000	302	461	340	92	90,5	1,4	0,052	GNA 180 SN-	471R
2030	2140	2360	2470	100	134	3000	276	470	347	90,6	88,8	1,7	0,063	GNA 180 SN-	271O
				105	141	3000	276	470	347	90,9	89,2	1,7	0,063	GNA 180 SN-	271P
				116	156	3000	276	470	347	91,6	90	1,7	0,063	GNA 180 SN-	271R
				122	164	3000	276	470	347	91,8	90,3	1,7	0,063	GNA 180 SN-	271T
1650	1740	1920	2010	80	107	2600	223	463	341	89,7	87,5	2,6	0,091	GNA 180 SN-	W72O
				84,4	113	2600	223	463	341	90,1	88	2,6	0,091	GNA 180 SN-	W72P
				93,1	125	3000	223	463	341	90,8	88,9	2,6	0,091	GNA 180 SN-	W72R
				97,5	131	3200	223	463	341	91,1	89,3	2,6	0,091	GNA 180 SN-	W72T
1070	1130	1250		53,5	72	1900	156	477	352	85,7	82,8	5,5	0,2	GNA 180 SN-	472O
				56,5	76	2300	156	477	352	86,3	83,5	5,5	0,2	GNA 180 SN-	472P
				62,5	84	2300	156	477	352	87,4	84,8	5,5	0,2	GNA 180 SN-	472R

Form Factor	< 1.03	Excitation Power	2100 W	Operating Mode	S 1	Weight	370 kg
Mech. limit speed	4000 RPM	Excitation current at 310V	6.A	Type of protection	IP 23	Uncompensated	
Moment of inertia	0.41 kgm <sup>2</sup>	Insulation material class	H	Type of cooling	IC 06		

**GNA 180 MN**

Speed n Armature voltage Ua of:				Out-put	Out-put	n max electr.	Arma- ture cur- rent:	Tor- que	Tor- que	Effectivity		Induc- tivity	Arma- ture circuit im- pedan- ce	Order Designation	
400 [V]	420 [V]	460 [V]	480 [V]	Pab [kW]	Pab [hp]	[min- 1]	Ia [A]	M [Nm]	M [lbf ft]	eta A [%]	eta tot [%]	La [mH]	Ra [Ohm]		
2580				150	201	3000	407	555	409	92	90,6	0,9	0,028	GNA 180 MN-	W71O
2720				158	212	3000	407	555	409	92,3	91	0,9	0,028	GNA 180 MN-	W71P
2990				174	233	3000	407	555	409	92,8	91,6	0,9	0,028	GNA 180 MN-	W71R
2210				133	178	3000	363	575	424	91,6	90	1,2	0,036	GNA 180 MN-	S71O
2330				140	188	3000	363	575	424	91,9	90,4	1,2	0,036	GNA 180 MN-	S71P
2560				154	207	3000	362	575	424	92,4	91,1	1,2	0,036	GNA 180 MN-	S71R
2680				161	216	3000	362	575	424	92,7	91,4	1,2	0,036	GNA 180 MN-	S71T
1710				107	143	2600	296	598	441	90,4	88,5	1,9	0,063	GNA 180 MN-	471O
1800				113	152	2800	296	598	441	90,7	88,9	1,9	0,063	GNA 180 MN-	471P
1990				125	168	2800	296	598	441	91,4	89,8	1,9	0,063	GNA 180 MN-	471R
1380				84,5	113	2100	236	585	431	89,5	87,2	2,9	0,09	GNA 180 MN-	Z71O
1460				89,4	120	2300	237	585	431	90	87,8	2,9	0,09	GNA 180 MN-	Z71P
1610				98,6	132	2700	236	585	431	90,7	88,7	2,9	0,09	GNA 180 MN-	Z71R
1680				103	138	2700	235	585	431	91	89	2,9	0,09	GNA 180 MN-	Z71T
1050				66	89	1800	189	600	443	87,3	84,5	4,7	0,146	GNA 180 MN-	S72O
1110				69,8	94	2000	189	600	443	87,8	85,2	4,7	0,146	GNA 180 MN-	S72P
1230				77,3	104	2100	189	600	443	88,8	86,3	4,7	0,146	GNA 180 MN-	S72R
1290				81,1	109	2100	189	600	443	89,2	86,8	4,7	0,146	GNA 180 MN-	S72T

Form Factor	< 1.03	Excitation Power	2300 W	Operating Mode	S 1	Weight	460 kg
Mech. limit speed	3000 RPM	Excitation current at 310V	7.A	Type of protection	IP 23	Uncompensated	
Moment of inertia	0.52 kgm <sup>2</sup>	Insulation material class	H	Type of cooling	IC 06		



GNA 180 LN

Speed n Armature voltage Ua of:				Out-put	Out-put	n max electr.	Arma- ture cur- rent:	Tor- que	Tor- que	Effectivity		Induc- tivity	Arma- ture circuit im- pedan- ce Ra	Order Designation	
400 [V]	420 [V]	460 [V]	480 [V]	Pab [kW]	Pab [hp]	[min- 1]	Ia [A]	M [Nm]	M [lbf ft]	eta A [%]	eta tot [%]	La [mH]			
2200				145	194	2400	395	629	464	91,8	90,2	1	0,031	GNA 180 LN-	W71O
2320				153	205	2400	395	629	464	92,1	90,6	1	0,031	GNA 180 LN-	W71P
1880				130	174	2400	356	660	487	91,4	89,7	1,4	0,04	GNA 180 LN-	S71O
1980				137	184	2400	355	660	487	91,8	90,1	1,4	0,04	GNA 180 LN-	S71P
2180				151	202	2400	355	660	487	92,3	90,8	1,4	0,04	GNA 180 LN-	S71R
2280				158	212	2400	355	660	487	92,6	91,1	1,4	0,04	GNA 180 LN-	S71T
1450				104	139	2200	290	685	505	89,7	87,5	2,2	0,07	GNA 180 LN-	471O
1530				110	148	2400	290	685	505	90,1	88,1	2,2	0,07	GNA 180 LN-	471P
1690				121	162	2400	290	685	505	90,8	88,9	2,2	0,07	GNA 180 LN-	471R
1770				127	170	2400	290	685	505	91,1	89,3	2,2	0,07	GNA 180 LN-	471T
1040				74	99	1600	211	679	501	87,7	84,9	4,2	0,125	GNA 180 LN-	W72O
1100				78,3	105	1900	211	679	501	88,2	85,5	4,2	0,125	GNA 180 LN-	W72P
1210				84,1	113	1900	210	679	501	89,1	86,6	4,2	0,125	GNA 180 LN-	W72R
1270				90,4	121	1900	210	679	501	89,5	87,1	4,2	0,125	GNA 180 LN-	W72T

Form Factor	< 1.03	Excitation Power	2450 W	Operating Mode	S 1	Weight 530 kg Uncompensated
Mech. limit speed	2450 RPM	Excitation current at 310V	7.5A	Type of protection	IP 23	
Moment of inertia	0.61 kgm <sup>2</sup>	Insulation material class	H	Type of cooling	IC 06	

**GNA 200 SN**

Speed n Armature voltage Ua of:				Out-put	Out-put	n max electr.	Arma- ture cur- rent:	Tor- que	Tor- que	Effectivity		Induc- tivity	Arma- ture circuit im- pedan- ce Ra	Order Designation	
400 [V]	420 [V]	460 [V]	480 [V]	Pab [kW]	Pab [hp]	[min- 1]	Ia [A]	M [Nm]	M [lbf ft]	eta A [%]	eta tot [%]	La [mH]	[Ohm]		
2800	2950	3240	3380	192	257	3800	519	655	483	92,6	91,5	0,58	0,017	GNA 200 SN-	Y71O
				202	271	3800	519	655	483	92,8	91,8	0,58	0,017	GNA 200 SN-	Y71P
	213	286	3800	499	629	464	93	92,1	0,58	0,017	GNA 200 SN-	Y71R			
	223	299	3800	498	629	464	93,2	92,3	0,58	0,017	GNA 200 SN-	Y71T			
2150	2260	2490	2600	153	205	3000	415	680	502	92,2	90,9	1,03	0,03	GNA 200 SN-	Y61O
				161	216	3400	414	680	502	92,5	91,2	1,03	0,03	GNA 200 SN-	Y61P
	177	237	3400	414	680	502	93	91,8	1,03	0,03	GNA 200 SN-	Y61R			
	185	248	3400	414	680	502	93,2	92,1	1,03	0,03	GNA 200 SN-	Y61T			
1870	1970	2170	2270	130	174	3000	355	664	490	91,5	90,1	1,51	0,044	GNA 200 SN-	K71O
				137	184	3000	355	664	490	91,9	90,5	1,51	0,044	GNA 200 SN-	K71P
	151	202	3000	355	664	490	92,4	91,1	1,51	0,044	GNA 200 SN-	K71R			
	158	212	3000	355	664	490	92,7	91,4	1,51	0,044	GNA 200 SN-	K71T			
1360	1430	1580	1650	95	127	2200	267	669	493	89,1	87,2	2,43	0,07	GNA 200 SN-	Y72O
				100	134	2300	266	669	493	89,6	87,7	2,43	0,07	GNA 200 SN-	Y72P
	111	149	2300	266	669	493	90,3	88,6	2,43	0,07	GNA 200 SN-	Y72R			
	116	156	2500	266	669	493	90,7	89	2,43	0,07	GNA 200 SN-	Y72T			

Form Factor	< 1.03	Excitation Power	2200 W	Operating Mode	S 1	Weight 515 kg Uncompensated
Mech. limit speed	3800 RPM	Excitation current at 310V	7.1A	Type of protection	IP 23	
Moment of inertia	0.086 kgm <sup>2</sup>	Insulation material class	H	Type of cooling	IC 06	

GNA 200 MN

Speed n Armature voltage Ua of:				Out-put	Out-put	n max electr.	Arma- ture cur- rent:	Tor- que	Tor- que	Effectivity		Induc- tivity	Arma- ture circuit im- pedan- ce	Order Designation	
400 [V]	420 [V]	460 [V]	480 [V]	Pab [kW]	Pab [hp]	[min- 1]	Ia [A]	M [Nm]	M [lbf ft]	eta A [%]	eta tot [%]	La [mH]	Ra [Ohm]		
2260				185	248	3800	500	782	577	92,5	91,3	0,94	0,02	GNA 200 MN-	Y71O
2380				195	261	3800	500	782	577	92,8	91,7	0,94	0,02	GNA 200 MN-	Y71P
2610				214	287	3800	498	782	577	93,2	92,2	0,94	0,02	GNA 200 MN-	Y71R
2730				223	299	3800	498	782	577	93,5	92,5	0,94	0,02	GNA 200 MN-	Y71T
1730				145	194	3000	395	800	590	91,8	90,3	1,24	0,035	GNA 200 MN-	Y61O
1820				152	204	3500	394	800	590	92,1	90,7	1,24	0,035	GNA 200 MN-	Y61P
2010				168	225	3800	395	800	590	92,7	91,4	1,24	0,035	GNA 200 MN-	Y61R
2100				176	236	3800	395	800	590	92,9	91,7	1,24	0,035	GNA 200 MN-	Y61T
1520				125	168	2300	343	785	579	91,1	89,4	1,82	0,05	GNA 200 MN-	K71O
1600				132	177	2500	343	785	579	91,5	89,9	1,82	0,05	GNA 200 MN-	K71P
1760				145	194	2800	342	785	579	92,1	90,6	1,82	0,05	GNA 200 MN-	K71R
1850				152	204	2800	343	785	579	92,4	91	1,82	0,05	GNA 200 MN-	K71T
1100				94	126	1800	264	816	602	88,8	86,8	2,93	0,081	GNA 200 MN-	Y72O
1160				99,1	133	2000	264	816	602	89,3	87,3	2,93	0,081	GNA 200 MN-	Y72P
1280				109	146	2000	264	816	602	90,1	88,3	2,93	0,081	GNA 200 MN-	Y72R
1340				115	154	2000	264	816	602	90,5	88,7	2,93	0,081	GNA 200 MN-	Y72T
720				59	79	1400	175	783	578	84,3	81,3	8,15	0,199	GNA 200 MN-	K72O
760				62,4	84	1600	175	783	578	84,9	82,1	8,15	0,199	GNA 200 MN-	K72P
840				69,2	93	1700	174	783	578	86,1	83,4	8,15	0,199	GNA 200 MN-	K72R
890				72,6	97	1700	175	783	578	86,7	84,2	8,15	0,199	GNA 200 MN-	K72T

Form Factor	< 1.03	Excitation Power	2550 W	Operating Mode	S 1	Weight	620 kg
Mech. limit speed	3800 RPM	Excitation current at 310V	8.2A	Type of protection	IP 23	Uncompensated	
Moment of inertia	1.03 kgm <sup>2</sup>	Insulation material class	H	Type of cooling	IC 06		

**GNA 200 LN**

Speed n Armature voltage U <sub>a</sub> of:				Out-put	Out-put	n max electr.	Arma- ture cur- rent:	Tor- que	Tor- que	Effectivity		Induc- tivity	Arma- ture circuit im- pedan- ce	Order Designation	
400 [V]	420 [V]	460 [V]	480 [V]	Pab [kW]	Pab [hp]	[min- 1]	I <sub>a</sub> [A]	M [Nm]	M [lbf ft]	eta A [%]	eta tot [%]	La [mH]	R <sub>a</sub> [Ohm]		
1760	1850	2040	2130	180	241	2900	488	976	720	92,2	90,9	0,89	0,023	GNA 200 LN-	Y71O
				189	253	3000	487	976	720	92,5	91,2	0,89	0,023	GNA 200 LN-	Y71P
				209	280	3000	487	976	720	93	91,9	0,89	0,023	GNA 200 LN-	Y71R
				218	292	3000	486	976	720	93,3	92,1	0,89	0,023	GNA 200 LN-	Y71T
1340	1410	1550	1630	140	188	2300	384	998	736	91,1	89,5	1,54	0,042	GNA 200 LN-	Y61O
				147	197	2700	383	998	736	91,5	89,9	1,54	0,042	GNA 200 LN-	Y61P
				162	217	3000	382	998	736	92,1	90,6	1,54	0,042	GNA 200 LN-	Y61R
				170	228	3000	384	998	736	92,4	91	1,54	0,042	GNA 200 LN-	Y61T
850	900	990	1040	92	123	1700	261	1034	763	88,1	85,7	3,7	0,096	GNA 200 LN-	Y72O
				97	130	1800	262	1034	763	88,7	86,4	3,7	0,096	GNA 200 LN-	Y72P
				107	143	1900	260	1034	763	89,5	87,4	3,7	0,096	GNA 200 LN-	Y72R
				113	152	2000	261	1034	763	89,9	87,9	3,7	0,096	GNA 200 LN-	Y72T

Form Factor	< 1.03	Excitation Power	2800 W	Operating Mode	S 1	Weight	750 kg
Mech. limit speed	3000 RPM	Excitation current at 310V	9.0A	Type of protection	IP 23	Uncompensated	
Moment of inertia	1.31 kgm <sup>2</sup>	Insulation material class	H	Type of cooling	IC 06		

GNA 225 SN

Speed n Armature voltage Ua of:				Out-put	Out-put	n max electr.	Arma- ture cur- rent:	Tor- que	Tor- que	Effectivity		Induc- tivity	Arma- ture circuit im- pedan- ce	Order Designation	
400 [V]	420 [V]	460 [V]	480 [V]	Pab [kW]	Pab [hp]	[min- 1]	Ia [A]	M [Nm]	M [lbf ft]	eta A [%]	eta tot [%]	La [mH]	Ra [Ohm]		
2610  2750  3020  3150				261	350	3200	686	928	684	92,5	91,6	0,42	0,012	GNA 225 SN-	S81O
				278	373	3200	712	966	712	93	92,2	0,42	0,012	GNA 225 SN-	S81P
				305	409	3200	710	966	712	93,5	92,7	0,42	0,012	GNA 225 SN-	S81R
				319	428	3200	709	966	712	93,6	92,9	0,42	0,012	GNA 225 SN-	S81T
2220  2340  2570  2680				231	310	3200	624	992	732	92,5	91,4	0,59	0,015	GNA 225 SN-	Y71O
				243	326	3200	624	992	732	92,7	91,8	0,59	0,015	GNA 225 SN-	Y71P
				267	358	3200	623	992	732	93,2	92,3	0,59	0,015	GNA 225 SN-	Y71R
				278	373	3200	621	992	732	93,4	92,6	0,59	0,015	GNA 225 SN-	Y71T
1680  1760  1940  2030				191	256	2500	520	1083	799	91,5	90,3	1,04	0,028	GNA 225 SN-	Y61O
				200	268	2800	518	1083	799	91,8	90,7	1,04	0,028	GNA 225 SN-	Y61P
				220	295	3000	518	1083	799	92,4	91,4	1,04	0,028	GNA 225 SN-	Y61R
				230	308	3000	518	1083	799	92,7	91,7	1,04	0,028	GNA 225 SN-	Y61T
1300  1370  1510  1580				142	190	2200	396	1043	769	89,6	88,1	1,72	0,044	GNA 225 SN-	K71O
				150	201	2500	396	1043	769	90,1	88,6	1,72	0,044	GNA 225 SN-	K71P
				165	221	2600	395	1043	769	90,8	89,4	1,72	0,044	GNA 225 SN-	K71R
				173	232	2600	394	1043	769	91,1	89,8	1,72	0,044	GNA 225 SN-	K71T
1080  1140  1260  1320				119	160	1700	333	1052	776	89,3	87,5	2,73	0,059	GNA 225 SN-	Y72O
				126	169	1800	333	1052	776	89,8	88	2,73	0,059	GNA 225 SN-	Y72P
				139	186	1900	333	1052	776	90,6	89	2,73	0,059	GNA 225 SN-	Y72R
				145	194	2000	333	1052	776	90,9	89,4	2,73	0,059	GNA 225 SN-	Y72T
880  930  1030  1080				95	127	1600	274	1031	760	86,7	84,5	3,55	0,089	GNA 225 SN-	V71O
				100	134	1800	274	1031	760	87,3	85,2	3,55	0,089	GNA 225 SN-	V71P
				111	149	1800	274	1031	760	88,3	86,3	3,55	0,089	GNA 225 SN-	V71R
				117	157	1800	274	1031	760	88,7	86,8	3,55	0,089	GNA 225 SN-	V71T

Form Factor	< 1.03	Excitation Power	2650 W	Operating Mode	S 1	Weight	730 kg
Mech. limit speed	3200 RPM	Excitation current at 310V	8.5A	Type of protection	IP 23	Uncompensated	
Moment of inertia	1.66 kgm <sup>2</sup>	Insulation material class	H	Type of cooling	IC 06		

**GNA 225 MN**

Speed n Armature voltage Ua of:				Out-put	Out-put	n max electr.	Arma- ture cur- rent:	Tor- que	Tor- que	Effectivity		Induc- tivity	Arma- ture circuit im- pedan- ce	Order Designation	
400 [V]	420 [V]	460 [V]	480 [V]	Pab [kW]	Pab [hp]	[min- 1]	Ia [A]	M [Nm]	M [lbf ft]	eta A [%]	eta tot [%]	La [mH]	Ra [Ohm]		
2060  2170  2380  2490				260	349	2800	699	1205	889	93	92	0,49	0,017	GNA 225 MN-	S81O
				274	367	2800	699	1205	889	93,3	92,3	0,49	0,017	GNA 225 MN-	S81P
				288	386	2800	670	1156	853	93,5	92,5	0,49	0,017	GNA 225 MN-	S81R
				302	405	2800	671	1156	853	93,7	92,8	0,49	0,017	GNA 225 MN-	S81T
1750  1840  2030  2120				225	302	2700	608	1228	906	92,6	91,4	0,73	0,018	GNA 225 MN-	Y71O
				237	318	2800	607	1228	906	92,9	91,8	0,73	0,018	GNA 225 MN-	Y71P
				261	350	2800	608	1228	906	93,4	92,4	0,73	0,018	GNA 225 MN-	Y71R
				273	366	2800	607	1228	906	93,6	92,6	0,73	0,018	GNA 225 MN-	Y71T
1030  1090  1200  1250				138	185	1800	383	1279	943	90,1	88,3	2,1	0,05	GNA 225 MN-	K71O
				146	196	1900	384	1279	943	90,5	88,8	2,1	0,05	GNA 225 MN-	K71P
				161	216	1900	383	1279	943	91,2	89,7	2,1	0,05	GNA 225 MN-	K71R
				167	224	1900	381	1279	943	91,5	90	2,1	0,05	GNA 225 MN-	K71T
850  900  990  1040				115	154	1500	322	1292	953	89,3	87,2	3,35	0,073	GNA 225 MN-	Y72O
				122	164	1600	323	1292	953	89,8	87,8	3,35	0,073	GNA 225 MN-	Y72P
				134	180	1700	322	1292	953	90,6	88,7	3,35	0,073	GNA 225 MN-	Y72R
				141	189	1800	322	1292	953	90,9	89,1	3,35	0,073	GNA 225 MN-	Y72T
700  730  810  850				97	130	1300	279	1319	973	86,7	84,4	4,36	0,105	GNA 225 MN-	V71O
				101	135	1700	275	1319	973	87,2	84,9	4,36	0,105	GNA 225 MN-	V71P
				112	150	1700	276	1319	973	88,2	86,1	4,36	0,105	GNA 225 MN-	V71R
				117	157	1700	276	1319	973	88,7	86,6	4,36	0,105	GNA 225 MN-	V71T

Form Factor	< 1.03	Excitation Power	3100 W	Operating Mode	S 1	Weight	860 kg
Mech. limit speed	2800 RPM	Excitation current at 310V	10.0A	Type of protection	IP 23	Uncompensated	
Moment of inertia	1.92 kgm <sup>2</sup>	Insulation material class	H	Type of cooling	IC 06		

GNA 225 LN

Speed n Armature voltage Ua of:				Out-put	Out-put	n max electr.	Arma- ture cur- rent:	Tor- que	Tor- que	Effectivity		Induc- tivity	Arma- ture circuit im- pedan- ce Ra	Order Designation	
400 [V]	420 [V]	460 [V]	480 [V]	Pab [kW]	Pab [hp]	[min- 1]	Ia [A]	M [Nm]	M [lbf ft]	eta A [%]	eta tot [%]	La [mH]	[Ohm]		
1720  1810  1990  2080				255	342	2200	685	1416	1044	93,1	91,9	0,62	0,016	GNA 225 LN-	S81O
				268	359	2200	685	1416	1044	93,3	92,2	0,62	0,016	GNA 225 LN-	S81P
				295	396	2200	684	1416	1044	93,8	92,8	0,62	0,016	GNA 225 LN-	S81R
				308	413	2200	683	1416	1044	94	93,1	0,62	0,016	GNA 225 LN-	S81T
1460  1540  1690  1770				218	292	2200	589	1426	1052	92,5	91,2	0,87	0,021	GNA 225 LN-	Y71O
				230	308	2200	590	1426	1052	92,8	91,6	0,87	0,021	GNA 225 LN-	Y71P
				252	338	2200	588	1426	1052	93,4	92,2	0,87	0,021	GNA 225 LN-	Y71R
				264	354	2200	588	1426	1052	93,6	92,5	0,87	0,021	GNA 225 LN-	Y71T
1080  1140  1250  1310				160	215	1900	439	1415	1044	91,1	89,4	1,62	0,038	GNA 225 LN-	Y61O
				169	227	2100	439	1415	1044	91,5	89,8	1,62	0,038	GNA 225 LN-	Y61P
				185	248	2100	437	1415	1044	92,1	90,6	1,62	0,038	GNA 225 LN-	Y61R
				194	260	2100	437	1415	1044	92,4	90,9	1,62	0,038	GNA 225 LN-	Y61T
850  890  980  1030				129	173	1700	359	1447	1067	89,7	87,6	2,6	0,059	GNA 225 LN-	K71O
				135	181	1900	357	1447	1067	90,1	88,1	2,6	0,059	GNA 225 LN-	K71P
				148	198	1900	355	1447	1067	90,8	89	2,6	0,059	GNA 225 LN-	K71R
				156	209	1900	356	1447	1067	91,2	89,4	2,6	0,059	GNA 225 LN-	K71T
710  740  820  860				109	146	1300	307	1463	1079	88,6	86,2	3,9	0,079	GNA 225 LN-	Y72O
				113	152	1400	303	1463	1079	89	86,7	3,9	0,079	GNA 225 LN-	Y72P
				126	169	1600	304	1463	1079	89,9	87,7	3,9	0,079	GNA 225 LN-	Y72R
				132	177	1600	304	1463	1079	90,3	88,2	3,9	0,079	GNA 225 LN-	Y72T

Form Factor	< 1.03	Excitation Power	3400 W	Operating Mode	S 1	Weight	1030 kg
Mech. limit speed	2200 RPM	Excitation current at 310V	11.0A	Type of protection	IP 23	Uncompensated	
Moment of inertia	2.3 kgm <sup>2</sup>	Insulation material class	H	Type of cooling	IC 06		

**GNA 250 SN**

Speed n Armature voltage Ua of:				Out-put	Out-put	n max electr.	Arma- ture cur- rent:	Tor- que	Tor- que	Effectivity		Induc- tivity	Arma- ture circuit im- pedan- ce	Order Designation	
400 [V]	420 [V]	460 [V]	480 [V]	Pab [kW]	Pab [hp]	[min- 1]	Ia [A]	M [Nm]	M [lbf ft]	eta A [%]	eta tot [%]	La [mH]	Ra [Ohm]		
2100  2210  2430  2540				314	421	3100	844	1425	1051	93	92,1	0,44	0,011	GNA 250 SN-	S81O
				330	443	3200	844	1425	1051	93	92,2	0,44	0,011	GNA 250 SN-	S81P
				363	487	3200	843	1425	1051	93,5	92,8	0,44	0,011	GNA 250 SN-	S81R
				379	508	3200	842	1425	1051	93,7	93	0,44	0,011	GNA 250 SN-	S81T
1600  1680  1850  1940				255	342	2400	687	1521	1122	92,7	91,7	0,75	0,017	GNA 250 SN-	W71O
				268	359	2600	685	1521	1122	93	92	0,75	0,017	GNA 250 SN-	W71P
				280	375	2800	654	1447	1067	93,2	92,2	0,75	0,017	GNA 250 SN-	W71R
				294	394	2800	656	1447	1067	93,4	92,5	0,75	0,017	GNA 250 SN-	W71T
1220  1290  1420  1480				195	261	2100	537	1526	1126	90,9	89,6	1,44	0,032	GNA 250 SN-	O71O
				206	276	2200	538	1526	1126	91,3	90	1,44	0,032	GNA 250 SN-	O71P
				227	304	2200	537	1526	1126	91,9	90,8	1,44	0,032	GNA 250 SN-	O71R
				237	318	2200	535	1526	1126	92,2	91,1	1,44	0,032	GNA 250 SN-	O71T
930  980  1080  1130				147	197	1800	413	1509	1113	89,1	87,4	2,46	0,052	GNA 250 SN-	G71O
				155	208	1800	412	1509	1113	89,5	87,9	2,46	0,052	GNA 250 SN-	G71P
				171	229	1800	411	1509	1113	90,3	88,9	2,46	0,052	GNA 250 SN-	G71R
				179	240	1800	410	1509	1113	90,7	89,3	2,46	0,052	GNA 250 SN-	G71T
570  600  660  700				89	119	1100	264	1488	1097	84,1	81,6	6,27	0,116	GNA 250 SN-	O72O
				94	126	1400	263	1488	1097	84,7	82,4	6,27	0,116	GNA 250 SN-	O72P
				103	138	1400	260	1488	1097	85,9	83,7	6,27	0,116	GNA 250 SN-	O72R
				109	146	1400	263	1488	1097	86,5	84,4	6,27	0,116	GNA 250 SN-	O72T

Form Factor	< 1.03	Excitation Power	3150 W	Operating Mode	S 1	Weight	900 kg
Mech. limit speed	3200 RPM	Excitation current at 310V	10.2A	Type of protection	IP 23	Uncompensated	
Moment of inertia	2.9 kgm <sup>2</sup>	Insulation material class	H	Type of cooling	IC 06		



**GNA 250 MN**

Speed n Armature voltage Ua of:				Out-put	Out-put	n max electr.	Arma- ture cur- rent:	Tor- que	Tor- que	Effectivity		Induc- tivity	Arma- ture circuit im- pedan- ce Ra	Order Designation	
400 [V]	420 [V]	460 [V]	480 [V]	Pab [kW]	Pab [hp]	[min- 1]	Ia [A]	M [Nm]	M [lbf ft]	eta A [%]	eta tot [%]	La [mH]	[Ohm]		
1700  1790  1970  2060				318	426	2600	857	1787	1318	92,8	91,8	0,59	0,013	GNA 250 MN-	S81O
				335	449	2800	857	1787	1318	93,1	92,2	0,59	0,013	GNA 250 MN-	S81P
				350	469	2800	817	1699	1253	93,2	92,4	0,59	0,013	GNA 250 MN-	S81R
				366	491	2800	817	1699	1253	93,5	92,7	0,59	0,013	GNA 250 MN-	S81T
1290  1360  1490  1560				250	335	2300	677	1851	1365	92,3	91,2	0,92	0,02	GNA 250 MN-	W71O
				264	354	2300	677	1851	1365	92,6	91,5	0,92	0,02	GNA 250 MN-	W71P
				289	388	2300	674	1851	1365	93,2	92,1	0,92	0,02	GNA 250 MN-	W71R
				302	405	2300	674	1851	1365	93,4	92,4	0,92	0,02	GNA 250 MN-	W71T
980  1030  1140  1190				188	252	1800	521	1832	1351	90,2	88,7	1,77	0,037	GNA 250 MN-	O71O
				198	266	1800	519	1832	1351	90,6	89,2	1,77	0,037	GNA 250 MN-	O71P
				219	294	1800	520	1832	1351	91,4	90,1	1,77	0,037	GNA 250 MN-	O71R
				228	306	1800	519	1832	1351	91,7	90,4	1,77	0,037	GNA 250 MN-	O71T
610  640  710  750				116	156	1300	333	1816	1339	87,1	84,9	3,76	0,084	GNA 250 MN-	W72O
				122	164	1400	331	1816	1339	87,6	85,5	3,76	0,084	GNA 250 MN-	W72P
				135	181	1400	331	1816	1339	88,6	86,6	3,76	0,084	GNA 250 MN-	W72R
				143	192	1400	333	1816	1339	89,1	87,2	3,76	0,084	GNA 250 MN-	W72T

Form Factor	< 1.03	Excitation Power	3300 W	Operating Mode	S 1	Weight 1100 kg Uncompensated
Mech. limit speed	2800 RPM	Excitation current at 310V	10.6A	Type of protection	IP 23	
Moment of inertia	3.5 kgm <sup>2</sup>	Insulation material class	H	Type of cooling	IC 06	

**GNA 250 LN**

Speed n Armature voltage Ua of:				Out-put	Out-put	n max electr.	Arma- ture cur- rent:	Tor- que	Tor- que	Effectivity		Induc- tivity	Arma- ture circuit im- pedan- ce	Order Designation	
400 [V]	420 [V]	460 [V]	480 [V]	Pab [kW]	Pab [hp]	[min- 1]	Ia [A]	M [Nm]	M [lbf ft]	eta A [%]	eta tot [%]	La [mH]	Ra [Ohm]		
1340  1410  1550  1620				315	422	2100	851	2245	1656	92,5	91,5	0,7	0,015	GNA 250 LN-	S81O
				331	444	2100	850	2245	1656	92,8	91,9	0,7	0,015	GNA 250 LN-	S81P
				364	488	2100	848	2245	1656	93,4	92,5	0,7	0,015	GNA 250 LN-	S81R
				381	511	2100	848	2245	1656	93,6	92,7	0,7	0,015	GNA 250 LN-	S81T
1020  1070  1180  1230				239	320	1800	651	2239	1651	91,9	90,5	1,18	0,024	GNA 250 LN-	W71O
				251	337	1800	648	2239	1651	92,2	90,9	1,18	0,024	GNA 250 LN-	W71P
				277	371	1800	648	2239	1651	92,8	91,6	1,18	0,024	GNA 250 LN-	W71R
				288	386	1800	646	2239	1651	93	91,9	1,18	0,024	GNA 250 LN-	W71T
770  810  890  930				181	243	1500	508	2247	1657	89,2	87,5	2,18	0,044	GNA 250 LN-	O71O
				191	256	1700	506	2247	1657	89,6	88	2,18	0,044	GNA 250 LN-	O71P
				209	280	1700	504	2247	1657	90,4	88,9	2,18	0,044	GNA 250 LN-	O71R
				219	294	1700	502	2247	1657	90,7	89,3	2,18	0,044	GNA 250 LN-	O71T
480  500  560  580				111	149	1100	324	2211	1631	85,8	83,3	4,69	0,099	GNA 250 LN-	W72O
				116	156	1200	320	2211	1631	86,3	83,9	4,69	0,099	GNA 250 LN-	W72P
				130	174	1200	322	2211	1631	87,5	85,3	4,69	0,099	GNA 250 LN-	W72R
				134	180	1200	319	2211	1631	87,9	85,7	4,69	0,099	GNA 250 LN-	W72T

Form Factor	< 1.03	Excitation Power	3650 W	Operating Mode	S 1	Weight 1300 kg Uncompensated
Mech. limit speed	2100 RPM	Excitation current at 310V	11.8A	Type of protection	IP 23	
Moment of inertia	4.35 kgm <sup>2</sup>	Insulation material class	H	Type of cooling	IC 06	

GNA 280 SN

Speed n Armature voltage Ua of:				Out-put	Out-put	n max electr.	Arma- ture cur- rent:	Tor- que	Tor- que	Effectivity		Induc- tivity	Arma- ture circuit im- pedan- ce	Order Designation
400 [V]	420 [V]	460 [V]	480 [V]	Pab [kW]	Pab [hp]	[min- 1]	Ia [A]	M [Nm]	M [lbf ft]	eta A [%]	eta tot [%]	La [mH]	Ra [Ohm]	
1530  1600  1760				412	552	2600	1098	2570	1896	93,7	92,9	0,43	0,007	GNA 280 SN- W81O
				431	578	2600	1091	2570	1896	93,9	93,1	0,43	0,007	GNA 280 SN- W81P
				474	636	2600	1091	2570	1896	94,4	93,6	0,43	0,007	GNA 280 SN- W81R
1210  1270  1390  1460				348	467	2100	940	2750	2028	93,3	92,3	0,72	0,012	GNA 280 SN- 171O
				366	491	2200	931	2750	2028	93,6	92,6	0,72	0,012	GNA 280 SN- 171P
				400	536	2400	925	2750	2028	94	93,2	0,72	0,012	GNA 280 SN- 171R
				420	563	2400	929	2750	2028	94,3	93,4	0,72	0,012	GNA 280 SN- 171T
1010  1060  1160  1220				293	393	2000	792	2775	2047	92,7	91,5	1,04	0,016	GNA 280 SN- W71O
				308	413	2100	789	2775	2047	93	91,9	1,04	0,016	GNA 280 SN- W71P
				337	452	2100	784	2775	2047	93,5	92,5	1,04	0,016	GNA 280 SN- W71R
				354	475	2100	788	2775	2047	93,7	92,8	1,04	0,016	GNA 280 SN- W71T
760  800  880  920				227	304	1500	627	2858	2108	90,7	89,3	1,84	0,029	GNA 280 SN- O71O
				239	320	1600	626	2858	2108	91,1	89,8	1,84	0,029	GNA 280 SN- O71P
				263	353	1600	624	2858	2108	91,8	90,6	1,84	0,029	GNA 280 SN- O71R
				275	369	1600	623	2858	2108	92,1	90,9	1,84	0,029	GNA 280 SN- O71T

Form Factor	< 1.03	Excitation Power	4000 W	Operating Mode	S 1	Weight	1360 kg
Mech. limit speed	3000 RPM	Excitation current at 310V	12.9A	Type of protection	IP 23	Uncompensated	
Moment of inertia	5.7 kgm <sup>2</sup>	Insulation material class	H	Type of cooling	IC 06		

## GNA 280 MN

Speed n Armature voltage U <sub>a</sub> of:				Out-put	Out-put	n max electr.	Arma- ture cur- rent: I <sub>a</sub>	Tor- que M	Tor- que M	Effectivity		In- duc- tivity L <sub>a</sub>	Arma- ture circuit imped- ance R <sub>a</sub>	Order Designation	
400 [V]	420 [V]	460 [V]	480 [V]	Pab [kW]	Pab [hp]	[min- 1]	[A]	[Nm]	[lbf ft]	eta A [%]	eta tot [%]	[mH]	[Ohm]		
1360				420	563	2200	1118	2949	2175	93,9	93	0,48	0,008	GNA 280 MN-	W81O
1430				442	593	2400	1117	2949	2175	94,2	93,3	0,48	0,008	GNA 280 MN-	W81P
1570				485	650	2650	1114	2949	2175	94,6	93,8	0,48	0,008	GNA 280 MN-	W81R
1080				337	452	2000	903	2976	2195	93,2	92,1	0,8	0,013	GNA 280 MN-	171O
1130				352	472	2100	897	2976	2195	93,4	92,4	0,8	0,013	GNA 280 MN-	171P
1240				386	518	2100	894	2976	2195	93,9	93	0,8	0,013	GNA 280 MN-	171R
1300				405	543	2200	896	2976	2195	94,2	93,2	0,8	0,013	GNA 280 MN-	171T
900				282	378	1800	761	2987	2203	92,5	91,2	1,16	0,018	GNA 280 MN-	W71O
940				294	394	2100	755	2987	2203	92,8	91,6	1,16	0,018	GNA 280 MN-	W71P
1040				325	436	2100	758	2987	2203	93,4	92,2	1,16	0,018	GNA 280 MN-	W71R
1080				338	453	2100	752	2987	2203	93,6	92,5	1,16	0,018	GNA 280 MN-	W71T
670				215	288	1300	594	3064	2260	90,5	88,9	2,16	0,032	GNA 280 MN-	O71O
710				228	306	1500	596	3064	2260	90,9	89,4	2,16	0,032	GNA 280 MN-	O71P
780				250	335	1500	594	3064	2260	91,6	90,2	2,16	0,032	GNA 280 MN-	O71R
810				260	349	1500	589	3064	2260	91,9	90,5	2,16	0,032	GNA 280 MN-	O71T

Form Factor	< 1.03	Excitation Power	4150 W	Operating Mode	S 1	Weight	1500 kg
Mech. limit speed	2650 RPM	Excitation current at 310V	13.4A	Type of protection	IP 23	Uncompensated	
Moment of inertia	6.4 kgm <sup>2</sup>	Insulation material class	H	Type of cooling	IC 06		

GNA 280 LN

Speed n Armature voltage Ua of:				Out-put	Out-put	n max electr.	Arma- ture cur- rent:	Tor- que	Tor- que	Effectivity		Induc- tivity	Arma- ture circuit im- pedan- ce	Order Designation	
400 [V]	420 [V]	460 [V]	480 [V]	Pab [kW]	Pab [hp]	[min- 1]	Ia [A]	M [Nm]	M [lbf ft]	eta A [%]	eta tot [%]	La [mH]	Ra [Ohm]		
1190  1250  1380				392	526	2000	1046	3143	2318	93,6	92,6	0,57	0,009	GNA 280 LN-	W81O
				411	551	2200	1044	3143	2318	93,9	92,9	0,57	0,009	GNA 280 LN-	W81P
				454	609	2200	1047	3143	2318	94,3	93,5	0,57	0,009	GNA 280 LN-	W81R
940  980  1080  1130				314	421	1900	846	3187	2351	92,7	91,5	0,9	0,014	GNA 280 LN-	171O
				327	439	2000	837	3187	2351	93	91,8	0,9	0,014	GNA 280 LN-	171P
				360	483	2000	838	3187	2351	93,5	92,5	0,9	0,014	GNA 280 LN-	171R
				377	506	2000	838	3187	2351	93,8	92,7	0,9	0,014	GNA 280 LN-	171T
780  820  900  950				270	362	1600	732	3306	2438	92,2	90,8	1,29	0,019	GNA 280 LN-	W71O
				284	381	1600	730	3306	2438	92,5	91,2	1,29	0,019	GNA 280 LN-	W71P
				312	418	1600	727	3306	2438	93,1	91,9	1,29	0,019	GNA 280 LN-	W71R
				329	441	1600	733	3306	2438	93,4	92,2	1,29	0,019	GNA 280 LN-	W71T
660  700  770  800				232	311	1400	636	3357	2476	91,2	89,6	1,64	0,027	GNA 280 LN-	S71O
				246	330	1600	639	3357	2476	91,6	90,1	1,64	0,027	GNA 280 LN-	S71P
				271	363	1600	638	3357	2476	92,3	90,9	1,64	0,027	GNA 280 LN-	S71R
				281	377	1600	633	3357	2476	92,5	91,2	1,64	0,027	GNA 280 LN-	S71T
580  610  670  710				203	272	1200	562	3342	2465	90,3	88,5	2,42	0,035	GNA 280 LN-	O71O
				214	287	1400	560	3342	2465	90,7	89	2,42	0,035	GNA 280 LN-	O71P
				235	315	1400	558	3342	2465	91,4	89,9	2,42	0,035	GNA 280 LN-	O71R
				249	334	1400	564	3342	2465	91,8	90,3	2,42	0,035	GNA 280 LN-	O71T

Form Factor	< 1.03	Excitation Power	4500 W	Operating Mode	S 1	Weight	1600 kg
Mech. limit speed	2300 RPM	Excitation current at 310V	14.5A	Type of protection	IP 23	Uncompensated	
Moment of inertia	7.2 kgm <sup>2</sup>	Insulation material class	H	Type of cooling	IC 06		

## Bearings and Shaft Loading

All machines have rolling-contact bearings. Normally, the floating bearing is on the drive side and the locating bearing is on the non-drive side. Machines with roller bearings on the drive side are only available for increased radial force. When placing your order, please state the radial forces.

### Bearing Assignment of Ball Bearings for A Side

Size	A side	B side
100	6208 2ZR C3	6306 2ZR C3
112	6210 2ZR C3	6209 2ZR C3
132	6212 2ZR C3	6211 2ZR C3
160	6214 2ZR C3	6212 2ZR C3
180	6213 C3	6310 2RSR C3
200	6314 C3	6310 2RSR C3
225	6316 C3	6311 2RSR C3
250	6219 C3	6313 ZR C3
280	6220 C3	6316 C3

### Bearing Assign. of Roller Bearings for A Side

Size	A side	B side
100	NU 208 E	6306 2ZR C3
112	NU 210 E	6209 2ZR C3
132	NU 212 E	6211 2ZR C3
160	NU 214 E	6212 2ZR C3
180	NU 2213 E	6310 2RSR C3
200	NU 314 E	6310 2RSR C3
225	NU 316 E	6311 2RSR C3
250	NU 2219 E	6313 ZR C3
280	NU 2220 E	6316 C3

### Relubrication Intervals

Sizes 100-200 - permanently lubricated

Sizes 225-250 - regreasing device with grease regulation on the A side

Size 280- regreasing device with grease regulation on the A and B sides

Lubrication intervals (operating hours)

Size	Speed [RPM]				
	1000	1500	2000	2500	3000
225, A-S	7500	4500	3000	2000	1500
250, A-S	6500	4000	2500	2000	1500
280, A-S	6500	3500	2000	1500	-----
B-S					

In the case of versions with ball bearings on the drive side, lubrication intervals can increase by one-and-a-half times.

The lubrication intervals are based on bearing manufacturer data for normal operating conditions. Use only lithium base-saponified special rolling-contact bearing grease for initial or regreasing.

### Determining the radial forces $F_R$

When using belt pulleys, the radial load is calculated according to the following formula:

$P$  = nominal power in kW

$$F_R = k \frac{2 \cdot 10^7 \cdot P}{n \cdot D} \quad [\text{N}]$$

$n$  = rated RPM speed in RPM

$D$  = disk diameter in mm

By approximation, the belt tension factor,  $k$ , is as follows:

$k = 1.8 \dots 2.5$  for V-belts

$k = 2.2 \dots 3.5$  for flat belts

(Observe the information provided by the belt manufacturer!)

To ensure safe transmission of the torque, it is necessary to exploit the feather key's entire bearing length. Ignoring this can lead to the risk of too high a level of compressive load per unit area on the feather key, which can result in a motor defect. Apart from this, when mounting drive elements (e.g. belt pulleys) you must always push them all the way to the shaft collar on the shaft end. Ignoring this can lead to the risk of the shaft breaking!

### Permissible Radial Forces $F_R$ at the Shaft End

All the bearings have rated service lives of approximately 20,000 operating hours. In this connection, you must not exceed the loading values stated below. The stated permissible radial forces  $F_R$  apply only to motors that are installed horizontally without additional axial forces. If axial forces occur, you must consult the manufacturer.

## Radial Force Diagrams

Sample diagram

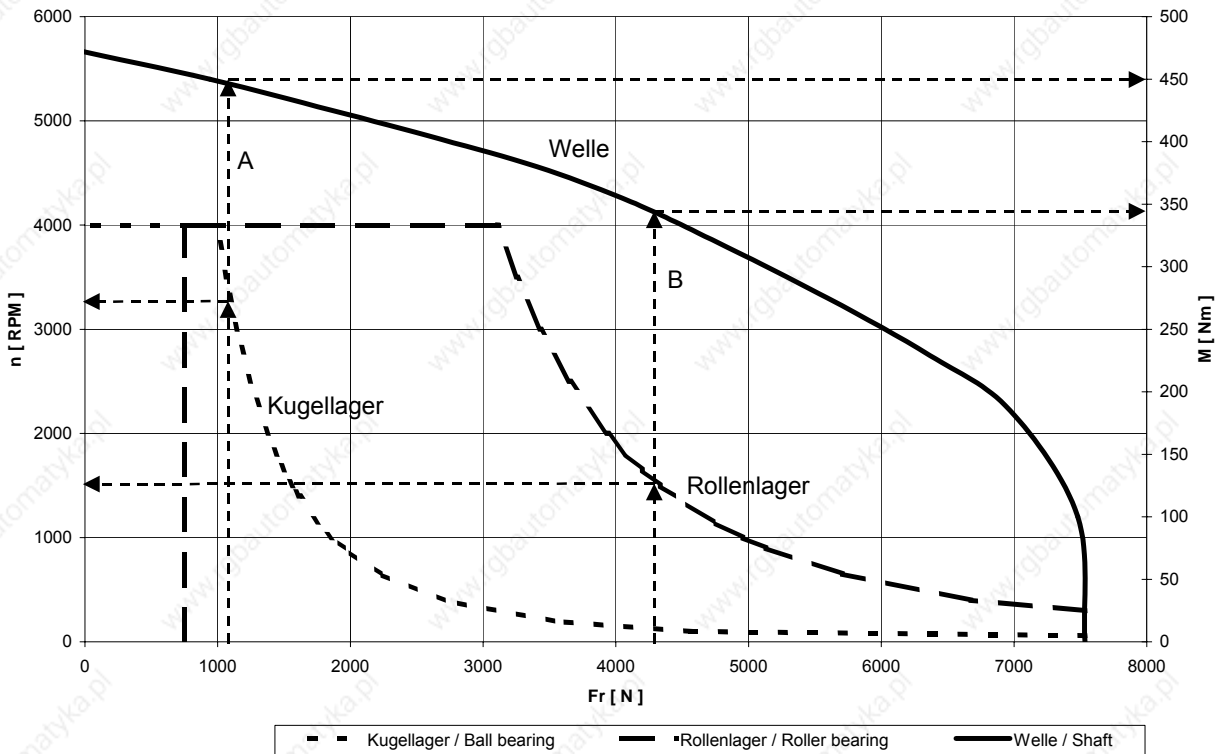

Explanation to the sample diagram

Force applied to end of shaft end (in case of force applied to middle of shaft end  $Fr \times 1.1$ )  
bearing life 20,000 h; shaft end with feather key groove

### Case A – ball bearings:

Using the application's radial force,  $Fr$ , you can determine in the ball bearing characteristic curve the bearing's maximum RPM speed.

Radial force 1100 N => maximum RPM speed 3250 RPM

The maximum torque that can still be transmitted results from the shaft characteristic curve.

Radial force 1100 N => torque that can still be transmitted 450 Nm

### Case B – roller bearings:

Using the application's radial force,  $Fr$ , you can determine in the roller bearing characteristic curve the bearing's maximum RPM speed.

Radial force 4300 N => maximum RPM speed 1500 RPM

The maximum torque that can still be transmitted results from the shaft characteristic curve.

Radial force 4300 N => torque that can still be transmitted 345 Nm

The roller bearing needs a minimum radial force of 800 N to ensure this bearing service life.

GN. 100 .N

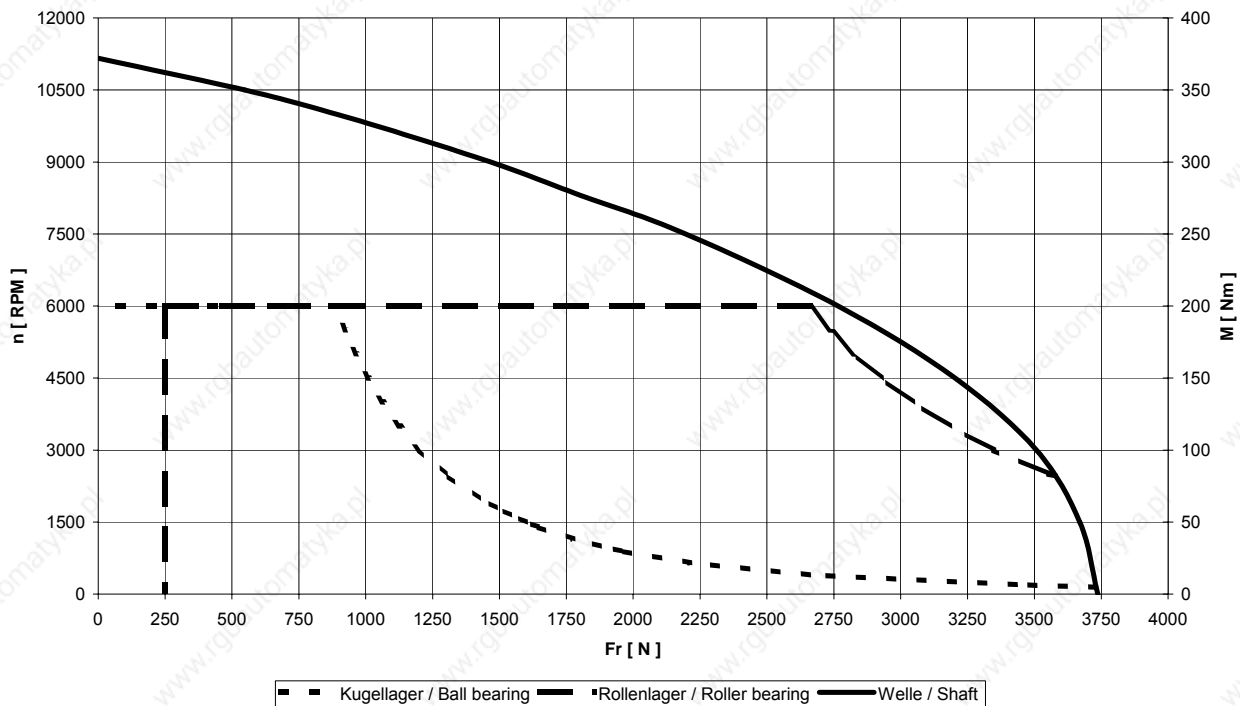

GN. 112 .N

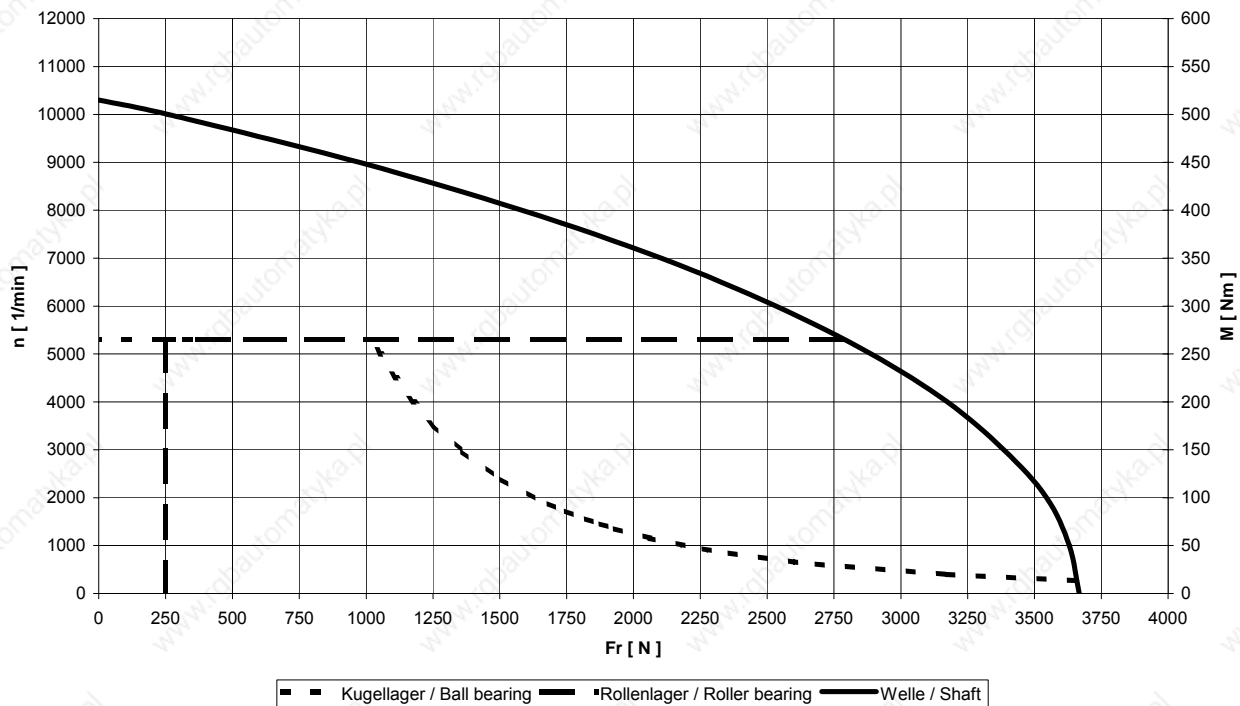



GN. 132 .N

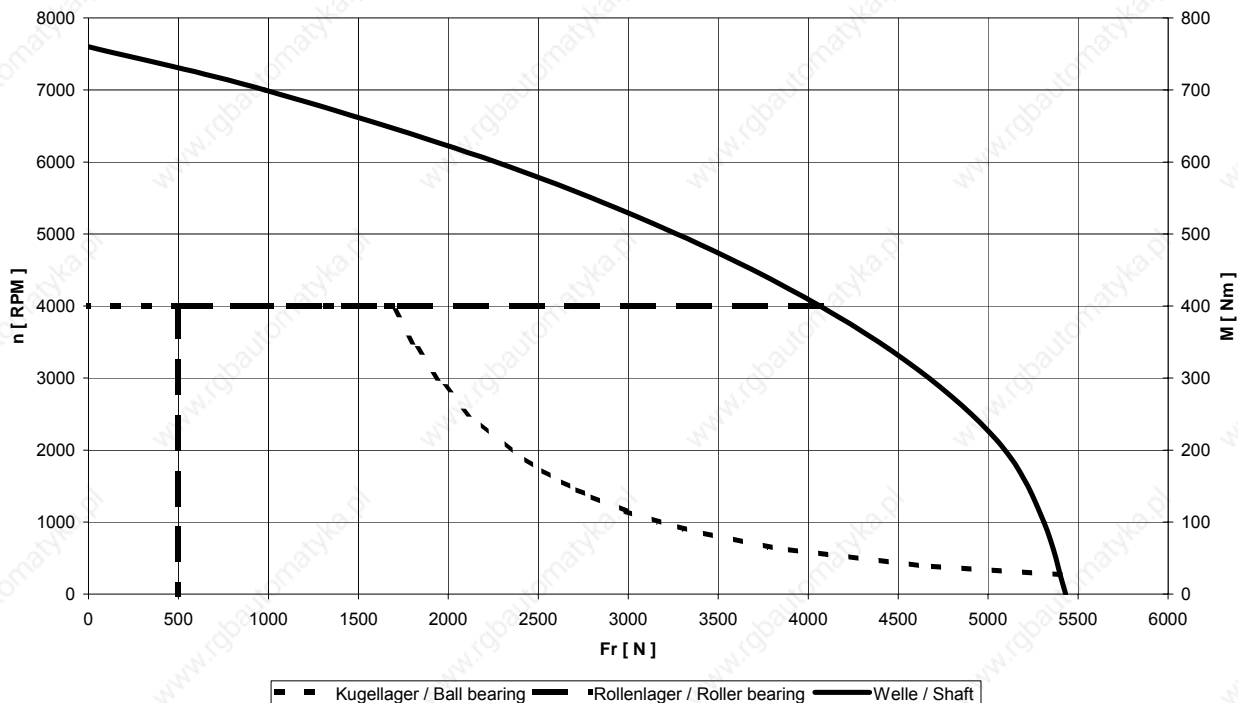

GN. 160 .N

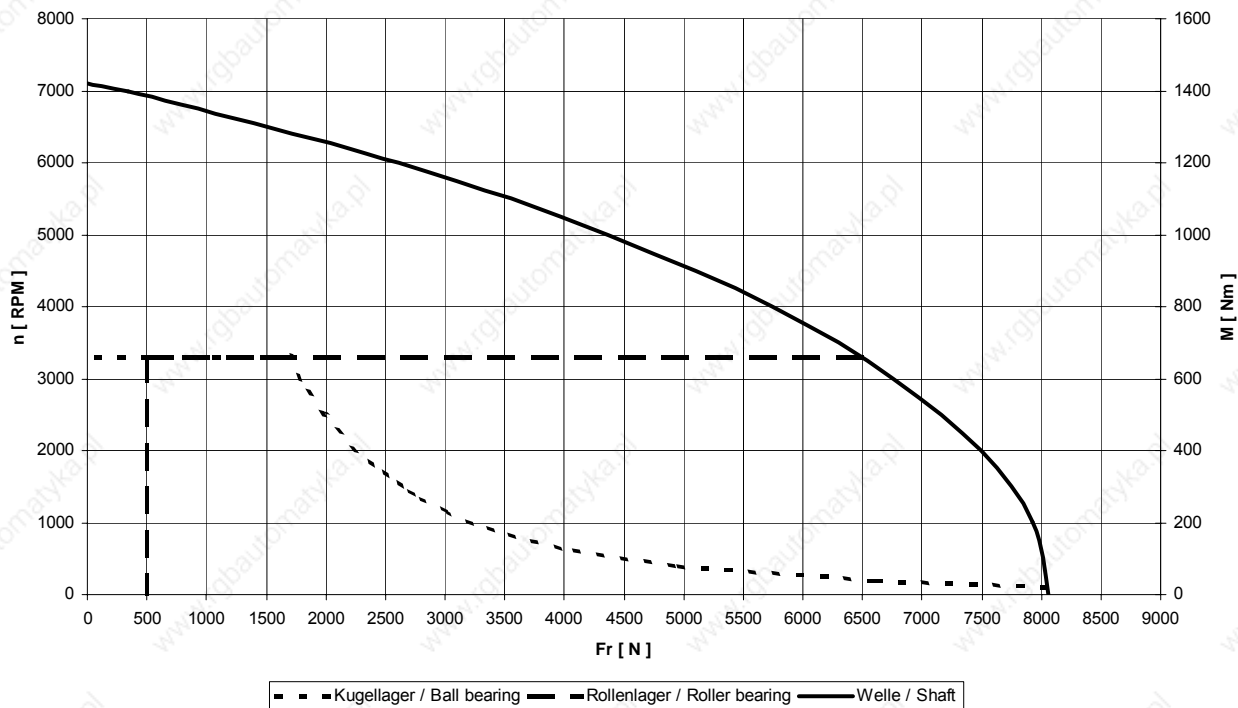

GN. 180 .N

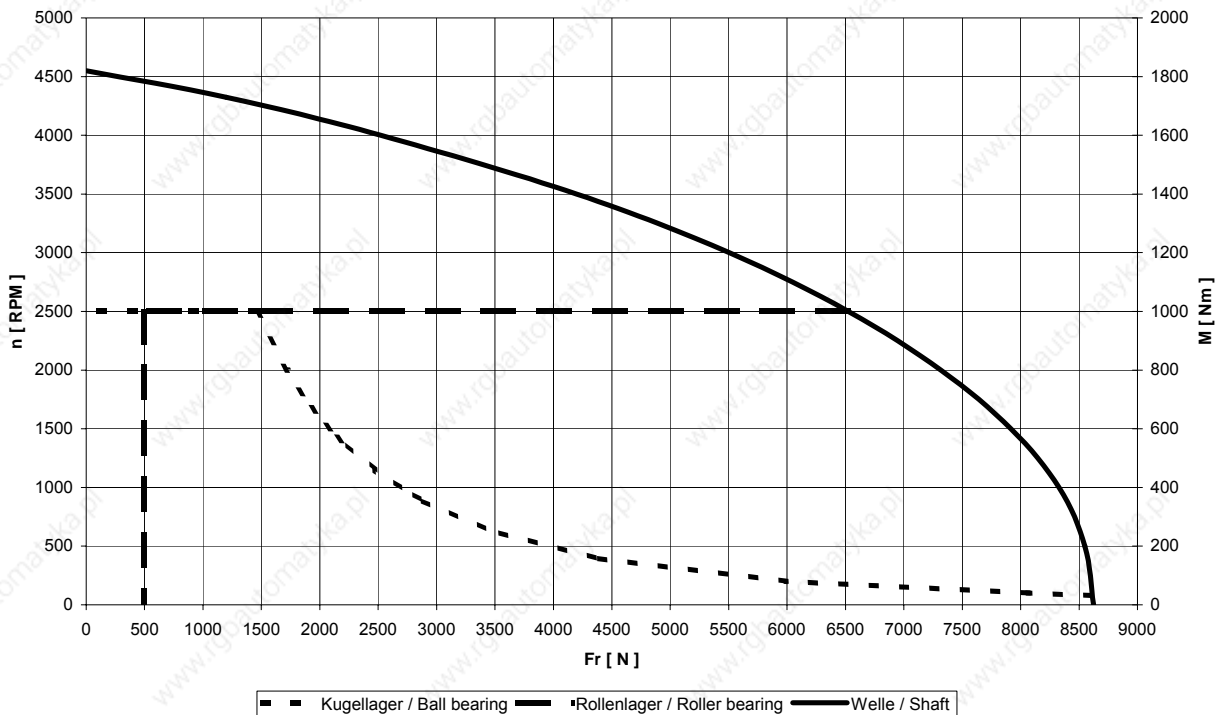

GN. 200 .N

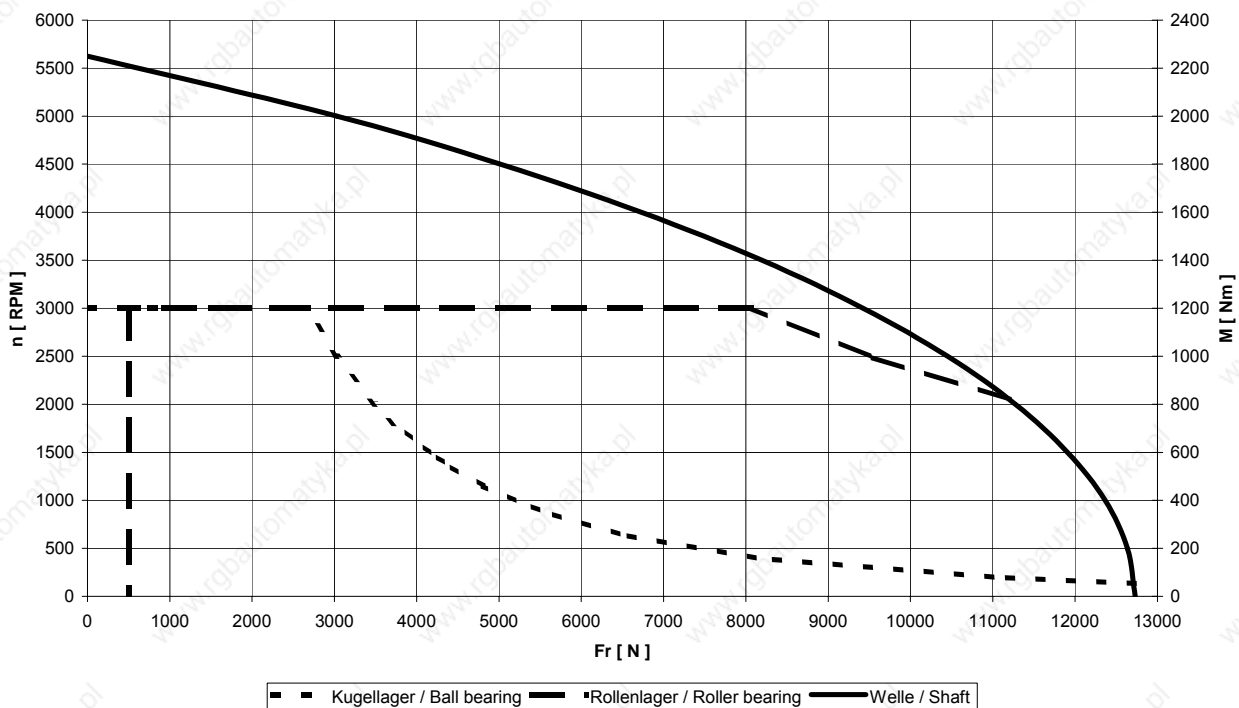

GN. 225 .N

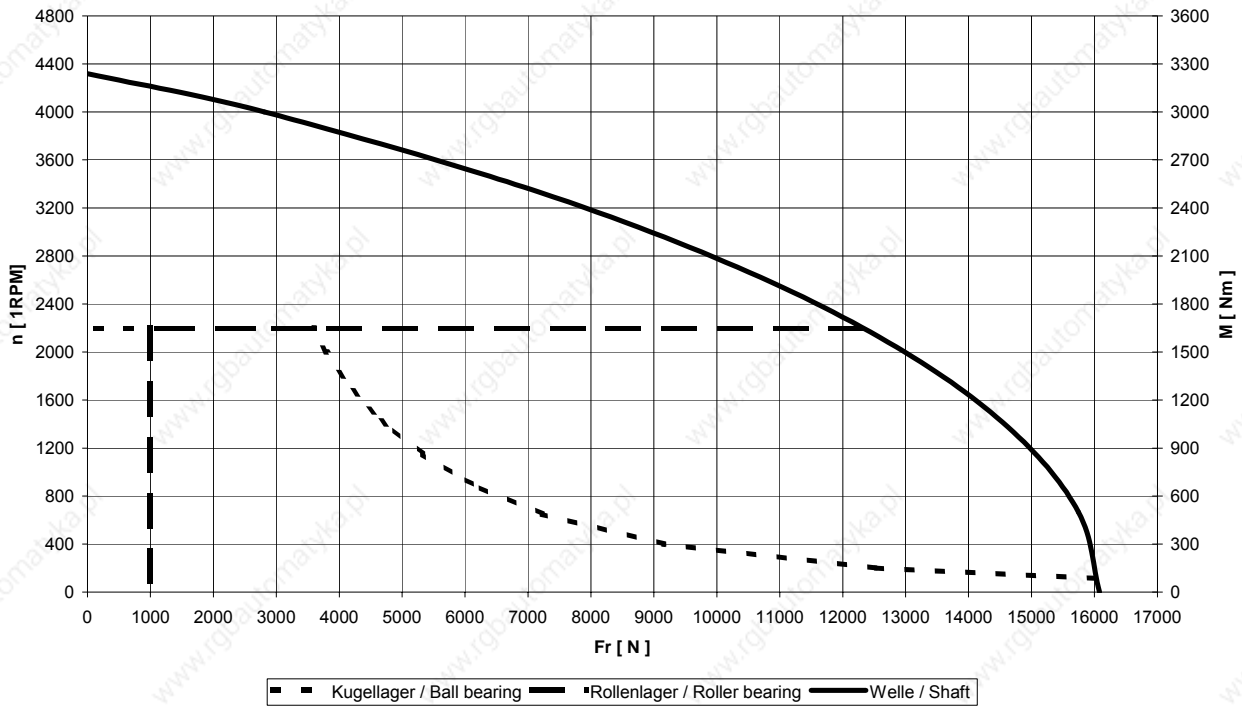

GN. 250 .N

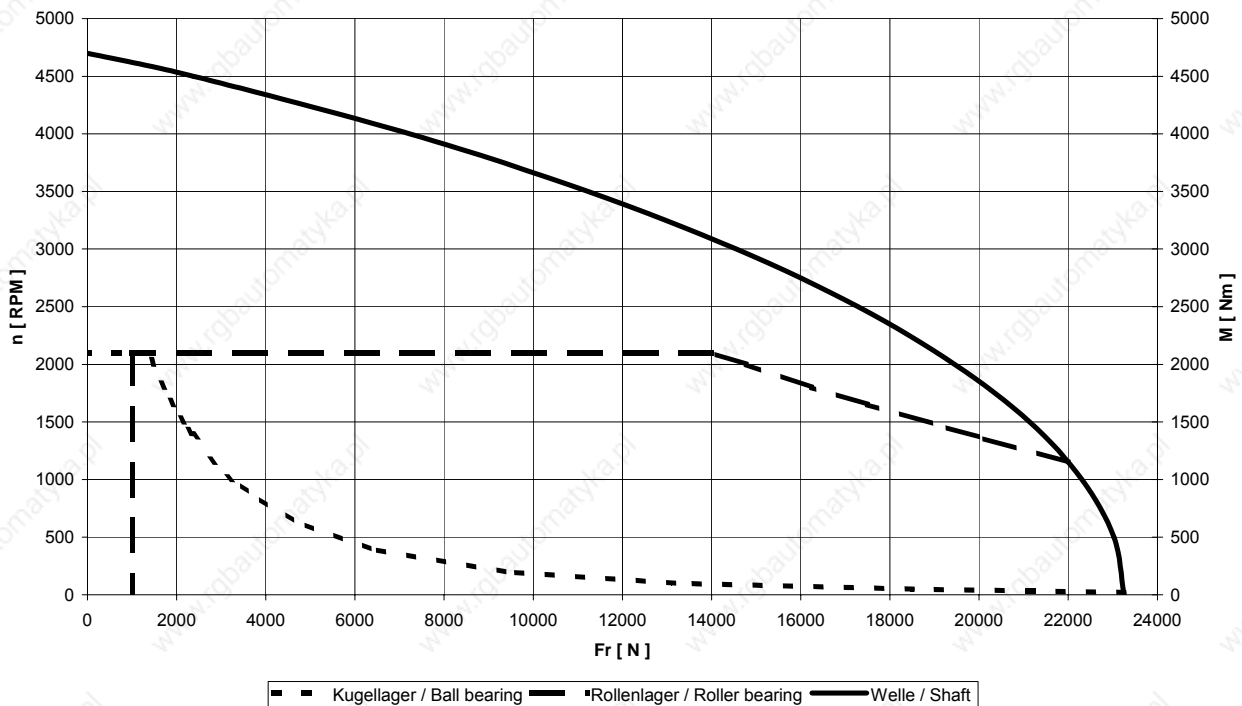

GN. 280 .N

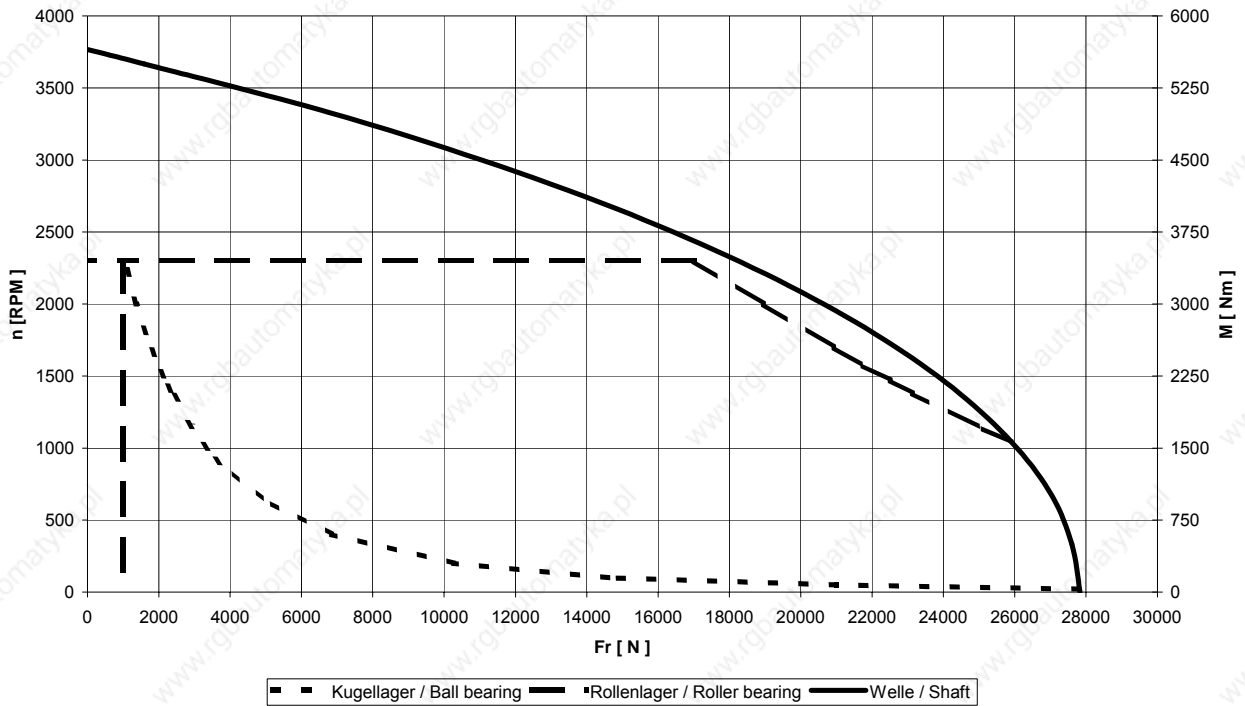

**Connection - Terminal Designation**

DC machines	Machine winding of type of winding or conductor in DC supply network	Connection designations according to DIN VDE 0530, Part 8, adapted to IEC 34-8
	Armature winding	A 1 - A 2
	Commutating winding Symmetrically divided	B1 - B2 1B1 - 1B2 2B1 - 2B2
	Commutating pole winding with compensating winding Symmetrically divided	C 1 - C 2 1C1 - 1C2 2C1 - 2C2
	Series field winding Series field winding - same winding sections on both sides of the armature	D1 - D2 1D1 - 1D2 2D1 - 2D2
	Shunt field winding	E1 - E2
	Field winding (separately excited)	F1 - F2
DC supply network	Positive conductor	L+
	Negative conductor	L -
	Middle conductor	M

## Temperature Monitoring

### Thermal protectors

As standard, motors are fitted with two thermal protectors for temperature monitoring one of which is in the commutating pole and the other in the field winding for switching off. On request, it is also possible to use PTC thermistors, KTY 84 temperature sensors or Pt100 measuring shunts. You can also use further temperature monitoring facilities, e.g. for alerts.

AC  $\cos \varphi$  1.0 250V 2.5A; 500V 0.75A; AC  $\cos \varphi$  0.6 250V 1.6A; 500V 0.5A; DC 24V 1.6A

The contacts are implemented as NC contacts.

### Temperature detector (option)

#### KTY84 - 130

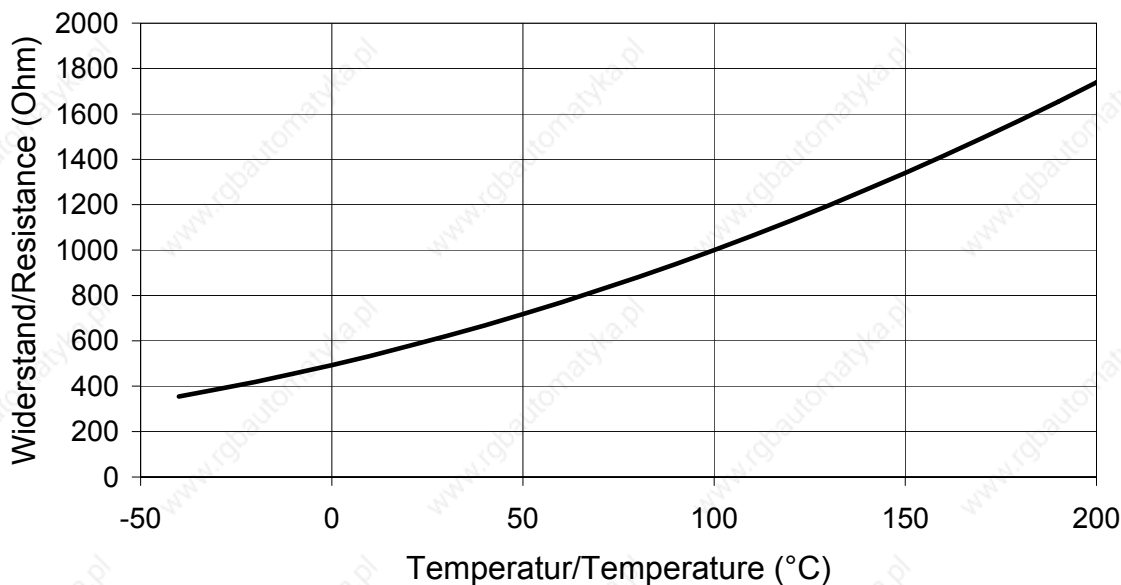

The KTY 84-130 temperature detector continuously monitors the motor temperature. Feeding a measuring current of 2 mA to the detector yields the resistance curve shown above.

### Brush monitoring

With the motors, you can optionally install potential-free microswitches to monitor the remaining length of the carbon brushes. Switching capacity of the microswitches:

Resistive load: 28 V DC - 7 A or 220 V AC - 3 A; Inductive load: 28 V DC - 4 A or 220 V AC - 2 A

Important: Operating voltage at least 12 -28 V, minimum current per contact of 15 mA;

The contacts open when the carbons are worn down.

## Noise level

(For internally cooled motors)

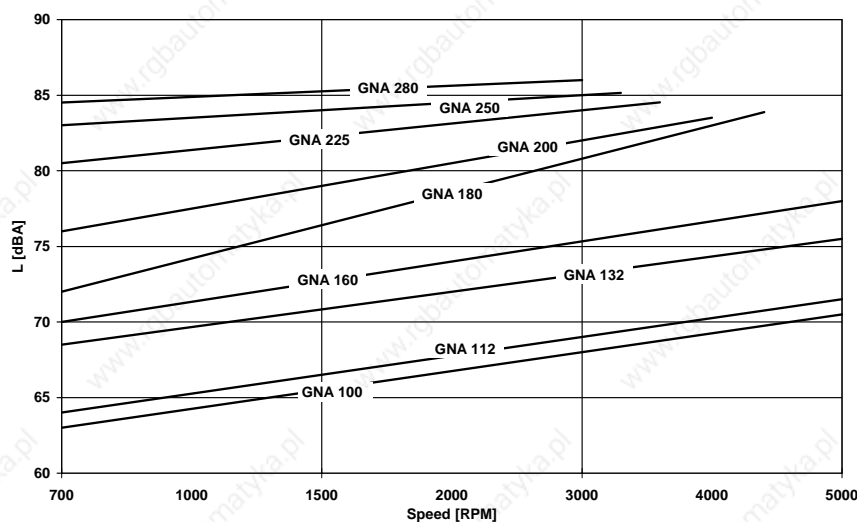

The internally ventilated motors do not exceed the limit values stipulated in EN 60034 -9  
A sound absorber reduces the noise level by 3 dBA.

## Vibration severity

Vibration class DIN EN 60034 -14	Speed [RPM]	Size		
		100-132	160-225 V <sub>eff</sub> [mm/s]	250-280
N (Normal)	600 - 1800	1,8	2,8	4,5
	1800 - 3600	1,8	2,8	4,5
	3600 - 6000	2,8	4,5	-
	6000 - 7500	4,5	-	-
R* (Reduced)	600 - 1800	0,71	1,12	1,8
	1800 - 3600	1,12	1,8	2,8
	3600 - 6000	1,8	2,8	-
	6000 - 7500	2,8	-	-
S* (Special)	600 - 1800	0,45	0,71	1,12
	1800 - 3600	0,71	1,12	1,8
	3600 - 6000	1,12	1,8	-
	6000 - 7500	1,8	-	-

\* R and S can only be executed with ball bearing.

To take into consideration the lifetimes of the brushes and the commutator as well as the bearing service life, you must limit the vibration values at the motor's place of installation that come from the driven machine and from the environment. The following maximum values (which are based on VDI 2056) are permissible. The values are measured at the motor's four test points.

Size	100 to 160 V <sub>eff</sub> [mm/s]	180 to 280 V <sub>eff</sub> [mm/s]
Max. permissible vibration severity	4.5	7.1

The motors are vibration-resistant at up to 3 g. Higher loads are possible on request.





## Brake assignment

for motor type	Brake type	Brake torque			Input power [W]	max. perm. switching energy Wperm. per switching operation [J]			Switching power Pperm. [kJ/h] for operating brake	Disengaging time [s] Switching operation	Engaging time [ms] Indiv. braking	Inertia [kgm²] Indiv. braking	max. perm. speed [min <sup>-1</sup> ]	Weight [kg]
		Operating brake [M2]	Holding brake [M4]	Peak load brake [M4]		Operating brake	Holding brake	Peak load brake						
<b>GN.100</b>	SB 50	30	50	-	80	4500	10000	-	470	120	160	0.0005	4000	5
<b>GN.112</b>	SB 100	60	100	60	106	5000	18000	70000	560	180	250	0.0015	3500	9.5
<b>GN.132</b>	SB 200	135	200	140	170	8000	20000	90000	630	225	300	0.0040	3000	13
<b>GN.160</b>	SB 200	135	200	140	170	8000	20000	90000	630	225	300	0.0040	3000	13

For use as a holding brake the following must be observed:

Brake has a considerably increased brake torque

3 emergency stops (individual braking operations) per hour possible if evenly distributed

Switching times values are valid for switching on the AC side, in a cold state, with basic air gap and holding brake

Disengaging time – Time until the brake has completely disengaged (brake without torque)

Engaging time – Time until the brake torque is reached

M2 ... dynamic torque, M4 ... static torque

All information are valid for the installation on a horizontal shaft

The supplier must be contacted before vertical installation.

Requirements other than those indicated on request.

### Braking time / switching energy / switching capacity

It is useful to check that the brake is suited for its application. To do this, the brake energy and braking power must be determined.

#### Determining the braking time

$$t_B = \frac{\sum J \cdot n_1}{9,55 \cdot (M_B \pm M_L)} + t_0 \text{ in s}$$

$\sum J$  Total moment of inertia in kgm<sup>2</sup> = J<sub>mot</sub> + J<sub>zus</sub> (relative to the motor shaft)

J<sub>mot</sub> Motor moment of inertia in kgm<sup>2</sup>

J<sub>zus</sub> Additional moment of inertia in kgm<sup>2</sup> (referred to the motor shaft)

n<sub>1</sub> Motor speed in RPM

M<sub>B</sub> Braking torque in Nm

M<sub>L</sub> Load torque in Nm (positively calculated if it decelerates, negatively calculated if it accelerates)

t<sub>0</sub> Time in s from the switching instant to the full extent of the braking torque (response time)

i Number of working cycles per hour

#### Determining the switching energy and switching capacity

Switching energy:

Switching capacity:

$$W_R = \frac{\sum J \cdot \Delta n^2}{182.4} \cdot \frac{M_B}{(M_B \pm M_L)} \quad \text{in } \frac{\text{Joule}}{\text{switching op.}} \quad P_R = \frac{W_R \cdot i}{1000} \quad \text{in } \frac{\text{kJ}}{\text{h}}$$

W<sub>Rperm</sub> ≤ Value from table

P<sub>Rperm</sub> ≤ Value from table

In most cases, t<sub>0</sub> is negligible. If this is not the case and the time t<sub>0</sub> must be reduced, you can achieve this by interrupting the magnet circuit on the DC side. However, this measure must be known before dimensioning the brake motor.

**Brake supply**

Normal voltage: 24; 96 - 120; 176V- (other voltages on request), 24 V: Supply with transformer and rectifier, 96 – 120 and 176 V: Supply using brake supply unit

The brakes can alternatively be equipped with microswitch or manually de-activated.

Switching capacity of microswitches

Ohmic load up to 30 V DC - 5 A or 250 V AC - 5 A

Inductive load up to 30 V DC -3 A or 250 V AC -2 A

The contact ratings apply to silver contacts

**Encoder**

**Direct voltage tachometers**

Type	Mounting	Direct voltage at 1000 RPM [V]	$n_{Max}$ [RPM]	Max. Nominal current [A]
GHT S 42	Hollow shaft	20	9000	0.01
GHT S 44	Hollow shaft	40	6000	0.01
GHT S 46	Hollow shaft	60	4000	0.01
REO 444 R	Coupling	60	12000	0.18
TDP 0.2 T-4	Coupling	60	9000	0.067

**Pulse encoder**

Type	Mounting	Number of pulses per revolution	Maximum frequency [kHz]	$n_{Max}$ [RPM]	Signal level [V]
DG 60 L	Coupling	125 to 5000	200	6000	5 / 24

**Pulse encoder connection**

Pin	Signal
1	$U_2$ inv.
2	+ 5V or + 24V sense
3	$U_0$
4	$U_0$ inv.
5	$U_1$
6	$U_1$ inv.
7	Alarm inv.
8	$U_2$
9	
10	0V
11	0V sense
12	+ 5V or + 24V

View towards contact side of mounting box

### Structural forms

The following designs are possible:

-IM B3, B6, B7, B8, B3/B5

Sizes 100-160 can be used in B5 to a maximum of vibration-resistant up to 3 g.

-IM V5, V6, V1/V5, V3/V6.

All normal versions of V structural forms can only be supplied in IP20 type of protection.

Higher types of protection on request.

#### Structural forms according to DIN EN 60034

IEC Code I	IEC Code II
IM B 3	IM 1001
IM B 5	IM 3001
IM B 6	IM 1051
IM B 7	IM 1061
IM B 8	IM 1071
IM B 14	IM 3601
IM B 35	IM 2001
IM B 34	IM 2101

IEC Code I	IEC Code II
IM V 1	IM 3011
IM V 3	IM 3031
IM V 5	IM 1011
IM V 6	IM 1031
IM V 18	IM 3611
IM V 19	IM 3631
IM V 15	IM 2011
IM V 36	IM 2031

Other structural forms on request.

Dimensional drawings

GNA 100 - 280 N (IM B3)

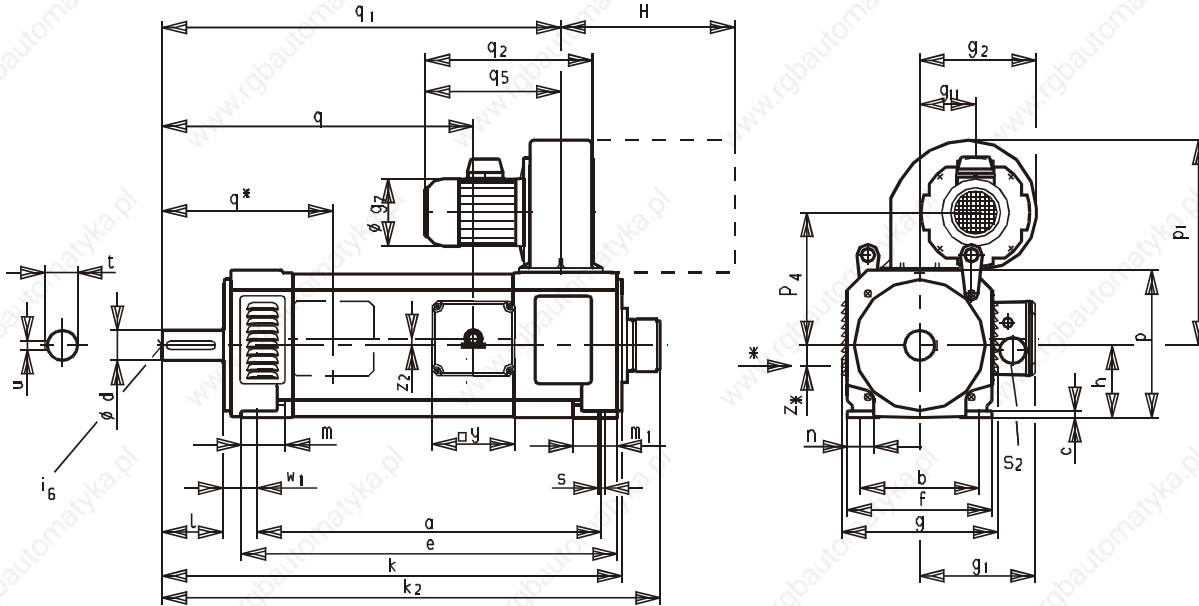

\* Dimensions with fan installed at side

Size	Shaft							Pedestal							Flange									
	d	l	t	u	$i_6$	$w_1$	a	b	c	e	f	C	$m/m_1$	n	$a_1$	$b_1$	$c_1$	$e_1$	$f_1$	$i_2$	$s_1$	$a_2$	z	A/B
100 SN	38	80	41	10	M 12	63	305	160	10	341	196	12	75	38	250	180	11	215	4	80	14	-	4	b
100 MN							360			396														
100 LN							410			446														
112 SN	42	110	45	12	M 16	56	460	190	10	490	220	12	59/46	50	300	230	14	265	4	110	14	240	4	A
112 MN							510			540														
112 LN							570			600														
132 KN	48	110	51.5	14	M 16	63	460	216	12	503	264	12	80/49	57	350	250	16	300	5	110	18	260	4	A
132 SN							510			553														
132 MN							590			633														
132 LN							690			733														
160 SN	60	140	64	18	M20	70	614	254	12	653	312	14	85/60	65	400	300	20	350	5	140	18	312	4	A
160 MN							724			763														
160 LN							834			873														
180 SN	65	140	69	18	M20	121	392	279	16	432	328	15	57	65	400	300	15	350	5	140	18	-	4	B
180 MN							502			542														
180 LN							572			612														
200 SN	70	140	74.5	20	M20	133	455	318	18	501	376	18	64	80	450	350	16	400	5	140	18	-	8	B
200 MN							540			586														
200 LN							660			706														
225 SN	80	170	85	22	M20	149	546	356	20	602	412	20	72	80	550	450	18	500	5	170	18	-	8	B
225 MN							646			702														
225 LN							746			802														
250 SN	90	170	95	25	M24	168	620	406	22	684	475	23	93	100	660	550	22	600	6	170	22	-	8	B
250 MN							725			789														
250 LN							865			929														
280 SN	95	170	100	25	M24	190	730	457	23	797	530	25	82	90	660	550	22	600	6	170	23	-	8	B
280 MN							800			867														
280 LN							880			947														

GNA 100 - 280 N (IM B35)

Positions of flange's drilled holes

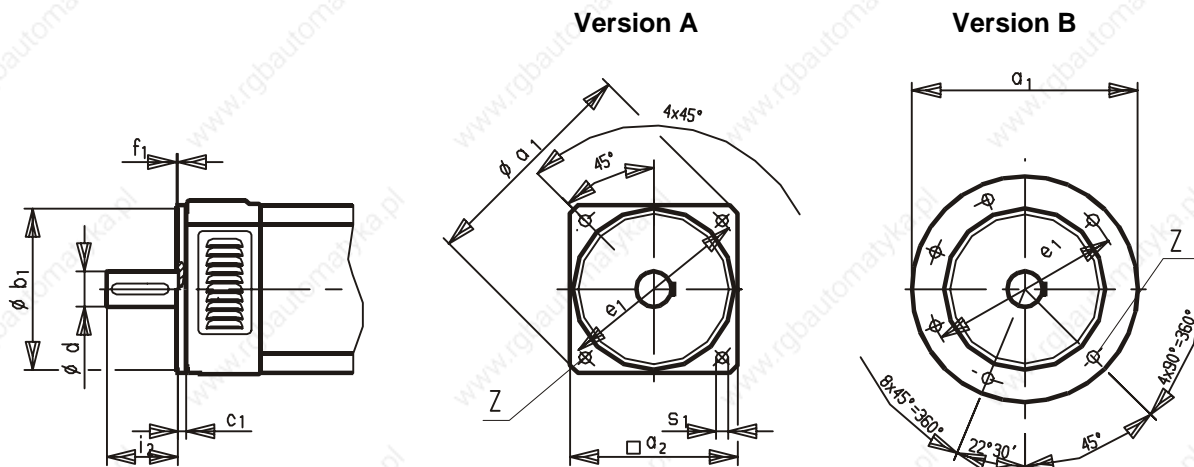

Centring in shaft ends according to DIN 332 shape D  
Version with a second shaft end on request  
k<sub>2</sub> with tachometer GHT

Fittings of shaft ends according to DIN 748 T3  
Flange version according to DIN 42948  
Forced ventilation can be rotated by 180°

Motor																				fan		* Dim. with fan mounted at side					
g	g <sub>1</sub>	g <sub>2</sub>	g <sub>7</sub>	g <sub>11</sub>	h	k	k <sub>2</sub>	p	p <sub>1</sub>	p <sub>4</sub>	q	q*	q <sub>1</sub>	q <sub>2</sub>	q <sub>5</sub>	S <sub>2</sub>	y	z <sub>2</sub>	H	Type	g* <sub>2</sub>	g* <sub>11</sub>	p* <sub>1</sub>	p* <sub>4</sub>	q* <sub>1</sub>	z*	
236	175	163	108	68	100	510	581	220	300	195	324	-	445	226	185	1M25	152	0	311	BFB 398	173	78	300	195	445	0	
						565	636				379		500			1M20									500		
						615	686				429		550													550	
245	205	173	108	78	112	652	725	230	310	205	388	314	558	226	185	2M40	190	0	311	BFB 398	173	78	330	225	558	0	
						702	775				438		608			1M20										608	
						762	835				498		668													668	
285	240	237	145	114	132	659	732	270	410	252	362	349	560	346	277	2M50	225	0	460	BFB 635	237	114	430	272	560	0	
						709	782				412		610			2M25										610	
						789	862				492		690													690	
						889	962				592		790													790	
340	265	269	179	125	160	856	930	324	480	300	522	390	738	387	317	2M50	225	0	570	BFB 752	269	125	495	315	722	0	
						966	1040				632		848			2M25										832	
						1076	1150				742		958													942	
385	380	269	179	125	180	944	1015	370	500	320	536	379	794	387	317	6M32	330	58.5	570	BFB 752	269	125	505	325	784	0	
						1054	1125				646		904			3M25										894	
						1124	1195				716		974													964	
425	400	312	200	147	200	1016	1090	410	580	365	616	385	881	485	385	6M32	330	72.5	860	BFB 880	312	147	590	375	881	0	
						1101	1175				701		966			3M25										966	
						1221	1295				821		1086													1086	
475	415	312	200	147	225	1188	1258	460	605	390	706	478	1021	485	385	10M40	372	37.5	860	BFB 880	262	97	615	400	1021	50	
						1288	1358				806		1121			2M25										1121	
						1388	1458				906		1221			2M20										1221	
525	440	382	260	181	250	1316	1386	510	710	465	807	489	1116	600	495	10M40	372	47.5	840	FB D09	342	141	720	475	1126	40	
						1421	1491				912		1221			2M25										1231	
						1561	1631				1052		1361			2M20										1371	
585	470	382	260	181	280	1470	1545	570	735	495	935	515	1252	600	495	10M40	372	37.5	840	FB D09	262	61	760	520	1260	120	
						1540	1615				1005		1322			2M25										1330	
						1620	1695				1085		1402			2M20										1410	

GNAG 100 - 280 N (motor with brake, IM B3)

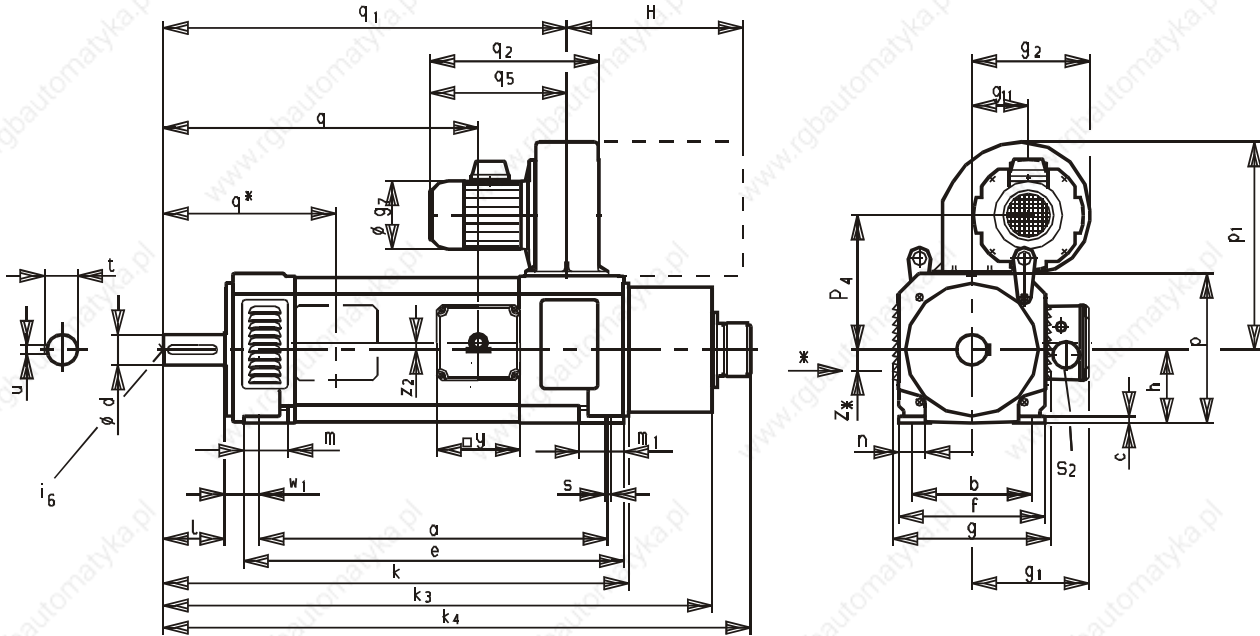

\* Dimensions with fan installed at side

Size	Shaft							Pedestal							Flange										
	d	l	t	u	i <sub>6</sub>	w <sub>1</sub>	a	b	c	e	f	C	m/m <sub>1</sub>	n	a <sub>1</sub>	b <sub>1</sub>	c <sub>1</sub>	e <sub>1</sub>	f <sub>1</sub>	i <sub>2</sub>	s <sub>1</sub>	a <sub>2</sub>	z	A/B	
100 SN	38	80	41	10	M	12	63	305	160	10	341	196	12	75	38	250	180	11	215	4	80	14	-	4	b
100 MN								360			396														
100 LN								410			446														
112 SN	42	110	45	12	M	16	56	460	190	10	490	220	12	59/46	50	300	230	14	265	4	110	14	240	4	A
112 MN								510			540														
112 LN								570			600														
132 KN	48	110	51.5	14	M	16	63	460	216	12	503	264	12	80/49	57	350	250	16	300	5	110	18	260	4	A
132 SN								510			553														
132 MN								590			633														
132 LN								690			733														
160 SN	60	140	64	18	M20	70		614	254	12	653	312	14	85/60	65	400	300	20	350	5	140	18	312	4	A
160 MN								724			763														
160 LN								834			873														
180 SN	65	140	69	18	M20	121		392	279	16	432	328	15	57	65	400	300	15	350	5	140	18	-	4	b
180 MN								502			542														
180 LN								572			612														
200 SN	70	140	74.5	20	M20	133		455	318	18	501	376	18	64	80	450	350	16	400	5	140	18	-	8	b
200 MN								540			586														
200 LN								660			706														
225 SN	80	170	85	22	M20	149		546	356	20	602	412	20	72	80	550	450	18	500	5	170	18	-	8	b
225 MN								646			702														
225 LN								746			802														
250 SN	90	170	95	25	M24	168		620	406	22	684	475	23	93	100	660	550	22	600	6	170	22	-	8	b
250 MN								725			789														
250 LN								865			929														
280 SN	95	170	100	25	M24	190		730	457	23	797	530	25	82	90	660	550	22	600	6	170	23	-	8	b
280 MN								800			867														
280 LN								880			947														

GNAG 100 - 280 N (motor with brake, IM B35)

Positions of flange's drilled holes  
Version A

Version B

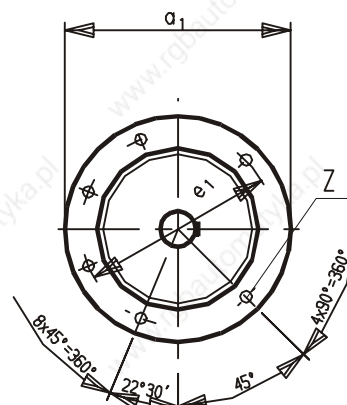
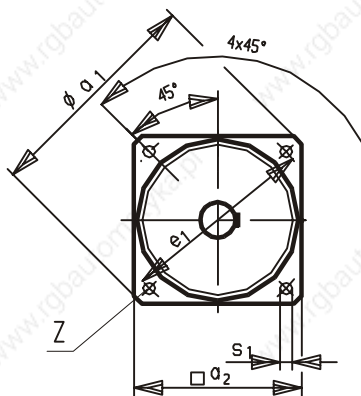
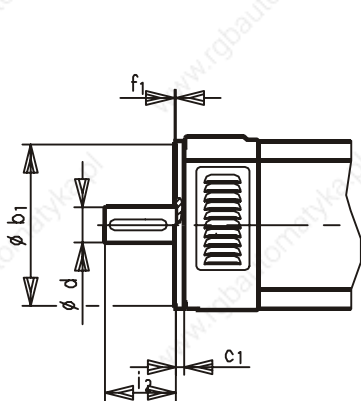

Centring in shaft ends according to DIN 332 shape D  
Version with a second shaft end on request  
k<sub>2</sub> with tachometer GHT  
k<sub>4</sub> with brake and tachometer GHT

Fittings of shaft ends according to DIN 748 T3  
Flange version according to DIN 42948  
k<sub>3</sub> with brake  
Forced ventilation can be rotated by 180°

Motor																				fan		* Dim. w. fan mounted at side					
g	g <sub>1</sub>	g <sub>2</sub>	g <sub>7</sub>	g <sub>11</sub>	h	k	k <sub>3</sub>	k <sub>4</sub>	p	p <sub>1</sub>	p <sub>4</sub>	q	q*	q <sub>1</sub>	q <sub>2</sub>	q <sub>5</sub>	S <sub>2</sub>	y	z <sub>2</sub>	h	Type	g <sub>2</sub> *	g <sub>11</sub> *	p <sub>1</sub> *	p <sub>4</sub> *	q <sub>1</sub> *	z*
236	175	163	108	68	100	510	595	680	220	300	195	324	-	445	226	185	1M25	152	0	311	BFB 398	173	78	300	195	445	0
						565	650	735				379		500			1M20										500
						615	700	785				429		550													550
245	205	173	108	78	112	652	755	830	230	310	205	388	314	558	226	185	2M40	190	0	311	BFB 398	173	78	330	225	558	0
						702	805	880				438		608			1M20										608
						762	865	940				498		668													668
285	240	237	145	114	132	659	770	850	270	410	252	362	349	560	346	277	2M50	225	0	460	BFB 635	237	114	430	272	560	0
						709	820	900				412		610			2M25										610
						789	900	980				492		690													690
						889	1000	1080				592		790													790
340	265	269	179	125	160	856	970	1045	324	480	300	522	390	738	387	317	2M50	225	0	570	BFB 752	269	125	495	315	722	0
						966	1080	1155				632		848			2M25										832
						1076	1190	1265				742		958													942
385	380	269	179	125	180	944	On request		370	500	320	536	379	794	387	317	6M32	330	58.5	570	BFB 752	269	125	505	325	784	0
						1054						646		904			3M25										894
						1124						716		974													964
425	400	312	200	147	200	1016	On request		410	580	365	616	385	881	485	385	6M32	330	72.5	860	BFB 880	312	147	590	375	881	0
						1101						701		966			3M25										966
						1221						821		1086													1086
475	415	312	200	147	225	1188	On request		460	605	390	706	478	1021	485	385	10M40	372	37.5	860	BFB 880	262	97	615	400	1021	50
						1288						806		1121			2M25										1121
						1388						906		1221			2M20										1221
525	440	382	260	181	250	1316	On request		510	710	465	807	489	1116	600	495	10M40	372	47.5	840	FB D09	342	141	720	475	1126	40
						1421						912		1221			2M25										1231
						1561						1052		1361			2M20										1371
585	470	382	260	181	280	1470	On request		570	735	495	935	515	1252	600	495	10M40	372	37.5	840	FB D09	262	61	760	520	1260	120
						1540						1005		1322			2M25										1330
						1620						1085		1402			2M20										1410

**Filter**

**Rectangular filter**

Dimensions with blower at top, with asterisk (\*) blower at side (in mm)

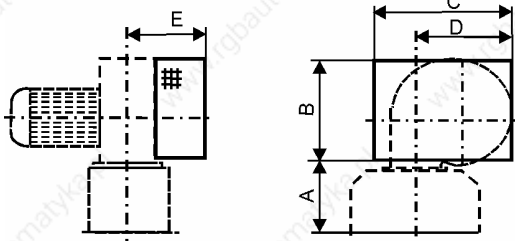

Filter to B side

View towards A side

Motor Size	Blower Type	A	A*	b	c	D	D*	e
100	BFB 398	120		176	246	147	157	145
112	BFB 398	130	150	176	246		157	145
132	BFB 635	158	178	236	336		235	189
160	BFB 752	190	206	276	386		271	280
180	BFB 752	210	215	276	386		271	280
200	BFB 880	244	254	336	476		332	410
225	BFB 880	269	279	336	476	332	282	410
250	FB D 09	297	307	336	476	404	364	432
280	FB D 09	326	351	336	476	404	284	432

**Round filter**

Dimensions with blower at top, with asterisk (\*) blower at side (in mm)

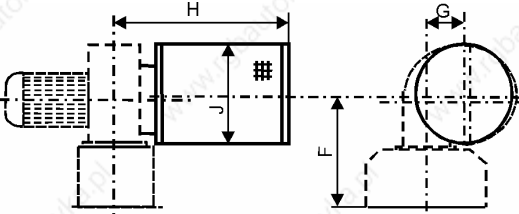

With sizes 100 and 250-280 filter to B side  
With sizes 112- 225 filter to A side

Motor Size	Blower Type	F	F*	G	G*	H	J
100	BFB 398	202		61	71	311	174
112	BFB 398	211	231		71	311	174
132	BFB 635	267	287		99	460	252
160	BFB 752	326	342		100	570	306
180	BFB 752	345	350		100	570	306
200	BFB 880	390	400		122	860	356
225	BFB 880	415	425	122	72	860	356
250	FB D 09	465	475	181	141	840	410
280	FB D 09	493	518	181	61	840	410

**Sound absorber**

Dimensions with blower at top, with asterisk (\*) blower at side (in mm)

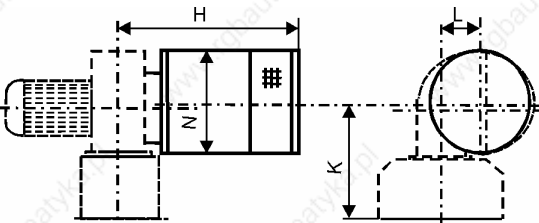

Up to size 280, sound absorber to A side  
A sound absorber to the B side is possible; in this case, the sound absorber must be supported on the customer side.  
In the case of sound absorbers at the side, support must be on the customer side.

Motor Size	Blower Type	K	K*	L	L*	H	N
100	BFB 398	--		--		--	--
112	BFB 398	--		--		--	--
132	BFB 635	267	287	99		460	256
160	BFB 752	326	342	100		580	306
180	BFB 752	345	350	100		580	306
200	BFB 880	390	400		122	860	356
225	BFB 880	415	425	122	72	860	356
250	FB D 09	490	500	156	116	921	406
280	FB D 09	518	543	156	36	921	406



## Encoder leads for pulse encoders

### Technical Data

#### 1. Technical description – non-trailing

- LiYCY, 5x (2x0.14mm<sup>2</sup>) + 2 x 0.5mm<sup>2</sup> copper litz wire, stranded in pairs
- Sheath PVC, grey
- 1st side: 12-pin round signal connector with 12 female contacts
- 2nd side: Free line end
- External diameter 8.5 mm (± 4 mm)
- Bending radius:  $r \geq 170$  mm
- Nominal voltage: 250V<sub>AC</sub>

#### 2. Technical description – trailing

- Li12YC11Y, 5x (2x0.14mm<sup>2</sup>) + 2 x 0.5mm<sup>2</sup> copper litz wire, stranded in pairs
- Sheath PUR, black
- 1st side: 12-pin round signal connector with 12 female contacts
- 2nd side: Free line end
- Labelled with Baumüller logo, white
- External diameter 8.0 mm (± 2 mm)
- Bending radius:  $r \geq 80$  mm (flexible application)
- Nominal voltage: 300V<sub>AC</sub>

### Application Information

#### Operating Temperatures

	Trailing	Non-trailing
Limit temperature	on the surface	on the surface
Application involving no movement/little movement	---	- 20° C to + 80° C
Application involving continuous movement	- 20° C to + 70° C	- 5° C to + 80° C

Laying the line on the motor  
The lines must not touch the motor surface.

Encoder lines/precut lines with connectors

**Encoder line**

**Non-trailing, precut**

Cable 5 x (2x0.14mm<sup>2</sup>) + 2 x 0.5 mm<sup>2</sup>

with connector

Length in m

article number

3	198665
5	197054
8	198794
10	197053
15	197052
20	197051
25	197050
30	198524
35	210416
40	215131
45	231706
55	212339
65	227194

**Encoder line**

**Trailing, precut**

Cable 5 x (2x0.14mm<sup>2</sup>) + 2 x 0.5 mm<sup>2</sup>

with connector

Length in m

article number

3	198962
5	198963
8	198964
10	198965
15	198966
20	198967
25	198968
30	198969
35	225360
40	208829

**Encoder connector**

Encoder connector

Article number

231086

Encoder connector

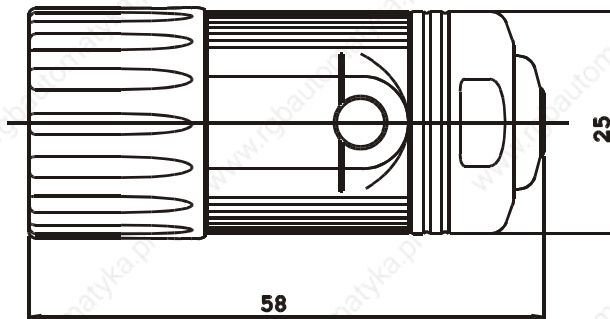

## Drive Center National

*Darmstadt*  
**Baumüller Nürnberg GmbH**  
Waldstraße 1 • D-64347 Griesheim  
Tel +49- (0)6155 8430-00 • Fax +49- (0)6155 8430-20

*Düsseldorf*  
**Baumüller Nürnberg GmbH**  
Jacob-Kaiser-Str. 7 • D-47877 Willich-Münchheide  
Tel +49- (0)2154-487-0 • Fax +49- (0)2154-487-59

*Dresden*  
**Baumüller Kamenz GmbH**  
Nordstraße 57 • D-01917 Kamenz  
Tel +49- (0)3578 3406-0 • Fax +49- (0)3578 3406-50

*Hannover*  
**Baumüller Nürnberg GmbH**  
Bohlenweg 10 • D-30853 Langenhagen  
Tel +49-(0)511 771968-0 • Fax +49- (0)511 771968-77

*Nürnberg*  
**Baumüller Nürnberg GmbH**  
Ostendstr. 80-90 • D-90482 Nürnberg  
Tel +49- (0)911-5432-501 • Fax +49- (0)911-5432-510

*Stuttgart*  
**Baumüller Nürnberg GmbH**  
Hahnweidstr. 21 • D-73230 Kirchheim / Teck  
Tel +49- (0)7021-48557-10 • Fax +49-(0)7021-48557-77

## Drive Center International

*Australia / Sydney Office*  
**Baumüller Australia Pty. Ltd.**  
19 Baker Street • Botany NSW 2019 • SYDNEY,  
Tel +61 2 83350-100 • F +61 2 83350-169

*Austria*  
**Baumüller Austria Ges.m.bH**  
Im Bäckerfeld 17 • A-4060 Leonding  
Tel +43 (0)732 674414-0 • Fax +43 (0)732 674414-32

*England*  
**Baumüller (UK) Ltd.**  
14 Redlands Centre • GB-Coulsdon, Surrey CR5 2HT  
Tel +44(0)208 76329-90 • Fax +44(0)208 76329-59

*France*  
**Baumüller France S.à.r.l.**  
Zone de la Malnoue  
39, Avenue de l'Europe • F- 77184 Emerainville  
Tel +33 1 6461-6622 • Fax +33 1 6461-6006

*India*  
**Baumüller KAT India Pvt. Ltd.**  
4<sup>th</sup> Floor, Commerce Avenue •  
Paud Road • IND- 411 038 Pune  
Tel +91 20 25459682 • Fax +91 20 25459684

*Italy*  
**Baumüller Italia s.r.l.,**  
Viale Italia, 12 • I-20094 Corsico (Mi),  
Tel +39 02 45100-181 • Fax +39 02 45100-426

*Spain*  
**Baumüller Ibérica S.A.**  
Ausias Marc, 13 1º 2º • E- 08010 Barcelona  
Tel +34 (0)93 34 26 926 • Fax +34 (0)93 27 01 321

*Switzerland*  
**Baumüller Suisse S.A.**  
Rue des Usines 22 • CH-2000 Neuchâtel  
Tel +41 (0)32 7301-260 • Fax +41 (0)32 7301-351

*The Netherlands*  
**Baumüller Benelux B.V.**  
Platinastraat 141 • NL-2718 SR Zoetermeer  
Tel +31(0)79-3614-290 • Fax +31(0)79-3614-339

*Turkey*  
**BAUMÜLLER MOTOR KONTROL SISTEM**  
**SAN. VE TIC. LTD. STI**  
Colak Ismail Sok., No:31/1 • TR-81070 Istanbul-Suadiye  
Tel +90 (0)216 372-2485 • Fax +90 (0)216 372-7570

*USA*  
**Baumüller Hartford Inc.**  
117 West Dudley Town Road • USA-Bloomfield,  
CT 06002  
Tel +1 860 -243 0232 • Fax +1 860 -286 3080

*USA*  
**Baumüller Chicago Corp.**  
1512 Algonquin Rd. • USA-Arlington Heights, Ill 60005  
Tel +1 847 956-7392 • Fax +1 847 956-7925

## Representatives International

*Brasil*  
**NC SERVICE INDÚSTRIA E COMÉRCIO LTDA.**  
Av. Juruá, 150, - Barueri - SP • BR- 06455 - 010  
Tel +55 (0)11 4195-0502 • Fax +55 (0)11 4195-2479

*China*  
**Beijing Yanghai Automation Technology Co., Ltd.**  
Room 1008, No.7, Huaqing Business Building,  
Iluaqing Garden, Wudaokou, Haidian  
District, Beijing 100083, P.R.C.  
Tel +86 (0)10 82867980 • Fax +86 (0)10 82867987

*China*  
**Sunary Automatic Technology Limited Company**  
3<sup>rd</sup> Floor No.476 Chunxiao Rd. Zhangjiang  
High-Tech Park Pudong, Shanghai 201203  
Tel +86 (0)21 50809898 • Fax +86 (0)21 53087675

*Denmark*  
**Robotek EL & Teknik A/S**  
Blokken 31 Postbox 30 • DK-3460 Birkerød  
Tel +45 4484 7360 • Fax +45 4484 4177

*Iran*  
**PAK GOSTAR Co.**  
502, 5th Floor, BORJ-E SEFID, PASDARAN Ave  
TEHRAN - IRAN  
Tel +98 21 2553868-70 • Fax + +98 21 2547703

*Korea*  
**BOMAC SYSTEMS**  
712 Yucheon Factopia • 196 Anyang-7 dong, Mananku,  
Anyangsi. • Kyungkido 430-017, Korea  
Tel +82 31 467-2030 • Fax +82 31 467-2033

*Poland*  
**Mekelburger Polska**  
Ul. Kościelna 39 F/3 • PL-60537 Poznań  
Tel. / Fax +48 (0)61-8481520

*Russia*  
**Permanent K&M**  
Wolokolamskoye Chaussee 73 • Office 517  
Moscow, 125424  
Tel +7 (0)95 9563867 • Fax +7 (0)95 7803429

*USA*  
**Industrial Drives Design, Inc.**  
668 Flinn Avenue Unit 28 • USA- Moorpark  
CA 93021  
Tel +1 805 378-1170 • Fax +1 805 378-1171

*Venezuela, Columbia, Ecuador*  
**Nimbus International C.A.**  
C.C. Parque Tuy, Local P-18  
YV-Ocumare del Tuy 1209  
Tel +58(0)239-2251347 • Fax +58(0)239-2257149

## Manufacturing locations

*Motors*  
**Baumüller Nürnberg GmbH**  
Ostendstraße 80- 90 • D-90482 Nürnberg  
Tel +49- (0)911-5432-0 • Fax +49- (0)911-5432-130

**Baumüller Nürnberg GmbH**  
Werk Kitzingen  
Floßhafenstraße 2 • D-97318 Kitzingen  
Tel +49- (0)9321-70080 • Fax +49- (0)9321-700888

**Baumüller Brno s.r.o.**  
Skalice nad Svitavou 72  
CZ- 67901 Skalice nad Svitavou,  
Tel +420 516-499 111 • Fax +420 516-499 117

**Baumüller Kamenz GmbH**  
Nordstraße 57 • D-01917 Kamenz  
Tel +49- (0)3578 3406-0 • Fax +49- (0)3578 3406-50

*Small Motors*  
**Baumüller Nürnberg GmbH**  
Werk Bad Gandersheim  
Flugplatzweg 2 • D-37581 Bad Gandersheim  
Tel +49- (0)5382 9805-0 • Fax 49- (0)5382 9805-55

*Electronics*  
**Baumüller Nürnberg GmbH**  
Ostendstraße 80- 90 • D-90482 Nürnberg  
Tel +49- (0)911-5432-293 • Fax +49- (0)911-5432-328

**Baumüller Dravinja d.o.o.**  
Delavska cesta 10 • SI-3210 Slovenske Konjice  
Tel +386 3-75723-00 • Fax +386 3-75723-32/33

## Systems

**Baumüller Anlagen-Systemtechnik GmbH & Co. KG**  
Ostendstraße 84 • D-90482 Nürnberg  
Tel +49- (0)911-54408-0 • Fax +49- (0)911-54408-749

## Services

**Baumüller Reparaturwerk GmbH & Co KG**  
Andernacher Straße 19 • D-90411 Nürnberg  
Tel +49- (0)911-9552-0 • Fax +49- (0)911-9552-999

*München*  
**Baumüller München GmbH**  
Meglingerstraße 58 • D-81477 München  
Tel +49- (0)89 748898-10 • Fax +49- (0)89 748898-75

**be in motion**

Responsible for content: Baumüller Nürnberg GmbH Ostendstraße 80-90 90482 Nürnberg T: +49(0)911 54 32-0 F: +49(0)911 54 32-130 [www.baumueller.com](http://www.baumueller.com)  
Baumüller Anlagen-Systemtechnik GmbH & Co. KG Ostendstraße 84 90482 Nürnberg T: +49(0)911 544 08-0 F: +49(0)911 544 08-719  
Baumüller Reparaturwerk GmbH & Co. KG Andernacher Str. 19 90411 Nürnberg T: +49(0)911 95 52-0 F: +49(0)911 95 52-999

All data/information and particulars given in this brochure is non-binding customer information, subject to constant further development and continuously updated by our permanent alteration service. Please note that all particulars/figures/information is current data at the date of printing. These particulars are not legally binding for the purpose of measurement, calculation or cost accounting. Prior to using any of the information contained in this brochure as a basis for your own calculations and/or applications, please inform yourself about whether the information you have at your disposal is up to date. Therefore, no liability is assumed for the correctness of the information.

3.136.e.03/05.10B  
**03/05**