

THYRO-A

AEG

SVS POWER SUPPLY
S Y S T E M S

**Universal Thyristorleistungssteller
Thyro-A Reihe A Typ 1A und 2A
mit sicherer Trennung**

**Universal Thyristor power controller
Thyro-A series A Type 1A and 2A
with safe disconnection**

Betriebsanleitung
Operating instructions

Contents

1.	General	22
2.	Block Circuit Diagram	23
3.	Technical Data	23
4.	Modes of operation	25
5.	Set value input	25
5.1	Process controller with current output	25
5.2	Process controller with voltage output or external potentiometre	26
5.3	Potentiometer "Life Zero"	26
6.	Notes on installation and connections	27
6.1	Installation	27
6.2	Connection diagram	28
6.2.1	Set value input	28
6.2.2	Connection Type 1A	29
6.2.3	Connection Type 2A	30
6.2.4	Connection of fan (1A/2A..280 HF)	31
7.	Initialisation	32
7.1	Operational elements (rated current 30..100 A)	32
7.2	Operational elements (130..280 A)	33
7.3	Switch settings	34
7.4	Adjusting the start of control with the "Life Zero" potentiometer	36
8.	Hints on troubleshooting	36
9.	Type series and spare parts	37
10.	Dimensions	39
11.	Proof of CE-Conformity	43

Important note on the following instructions

Important

AEG Stromversorgungs-Systeme GmbH, hereinafter called AEG SVS, gives no explicit or implicit guarantee of either a general or specific nature with regard to these instructions. The operating instructions are intended as information only. Their content does not form part of the contract. AEG SVS reserves the right to make technical or other modifications to these instructions. AEG SVS does not accept liability for any inaccuracies or inexact information in these operating instructions, as it is under no obligation continuously to update their content or ensure that they comply with the most recent technical developments. AEG SVS may however change these instructions to reflect recent technical developments without however giving notification of these changes.

The reproduction and distribution of the data and illustrations in these instructions as well as their use for the purpose of competition is prohibited. We reserve the right to apply all the provisions of copyright law.

Note: All persons working with this equipment must read these instructions carefully before it is put into use.

These instructions apply specifically to the Thyro-A type 1A and 2A and must be easily accessible for reference at all times.

Should spare parts other than those manufactured by or purchased from AEG SVS be used for the maintenance or repair of the equipment, AEG SVS will terminate without notice all the agreements made by it and its dealers with regard to the guarantee, service contracts etc.

Should any fault or malfunction occur in equipment supplied by AEG SVS, please contact our service department (hotline 02902/763-249) immediately.

Important data:

Please fill in the following data:

Type	1A/2A—.....
E-Nr. (serial no.)	
Fb.-Nr. (production no.)	
Data of first commissioning	

The type, E-no. and Fb.-numbers can be found on the machine plate of the Thyro-A type 1A and 2A.

Important

Maintenance and servicing of the Thyro-A type 1A and 2A

When carrying out servicing on the Thyro-A type 1A and 2A it must be disconnected from all external voltage sources and secured from being switched on unintentionally. The absence of voltage must be verified using a suitable measuring instrument. Maintenance and servicing work should be carried out only by qualified electricians. Local regulations applying to electrical equipment must be observed at all times.

Terms of delivery

All products and services supplied by us are subject to the General Conditions of Supply of the electrical industry and to our own General Conditions of Business. We reserve the right to alter the data contained in these instructions (in particular the technical data) as well as the operating procedures, dimensions and weights. Any complaints with regard to products supplied by us must be submitted to us within eight days of receipt of the products. The packaging or delivery note should be enclosed with the complaint. No responsibility will be accepted for complaints submitted at a later date.

1. General

The Thyro-A series A are power controller for full oscillation cycle (TAKT) and phase angle operational modes (VAR).

The power controller are suitable for the direct supply of ohmic users or as a primary regulating unit for a transformer.

Adjusting the operational modes and other operational parameters is effected by means of switches and potentiometers. The LED "On" indicates the Thyro-A to be operationally ready.

Thyro-A is set to transformer-load and operational mode TAKT by the manufacturer in such a way that it switches the first semiwave of each full wave group on with an phase angle 80° el. (type 1A) respectively 90° el. (type 2A). The transformer therefore is switched on virtually at zero current passage. The adjustment of the phase angle is fixed. The induction of the transformer should not exceed 1.1 T even at mains voltage.

Thyro-A type 1A/2A (rated current 30..100 A) according to standard for "Component-Switches, Industrial Control" (UL-File 135074) from Underwriters Laboratories Inc.
Thyro-A type 1A/2A are CE-conform (see page 43).

The Thyro-A A series consists of:

Type 1A for single phase ac. voltage (operational modes TAKT/VAR)

Type 2A for three-phase saver circuit (operational mode TAKT)

Type 2A is constructed from two power controller of type 1A which differ as follows:

Master: Lead switch (left part)

Slave: Secondary switch controlled by the Master (right part).

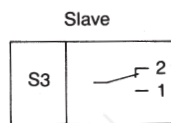
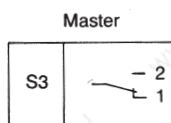
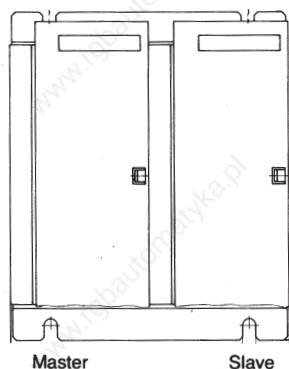

Master and Slave for Type 2A

The control and mains supply connections are effected using multi-pole connectors with screw fastenings, accessible from underneath the device.

2. Block Circuit Diagram

Block circuit diagram type 1A

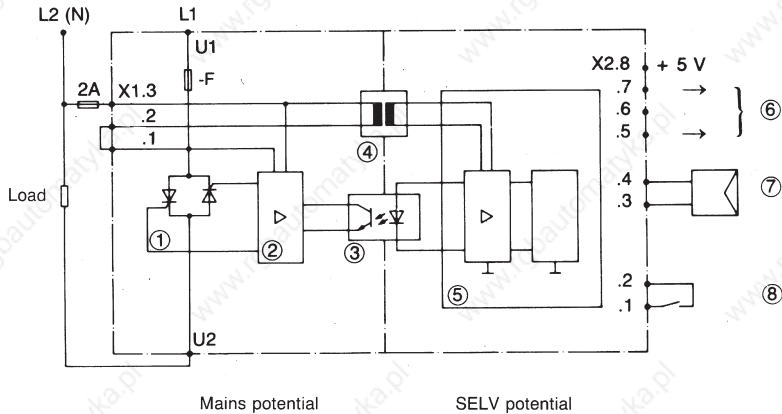

- | | |
|----------------------------|--------------------------|
| ① Power section | ⑤ Control electronics |
| ② Control power section | ⑥ Connection to 2A slave |
| ③ Optocoupler | ⑦ Verfahrnsregeler |
| ④ Power supply transformer | ⑧ Pulse gate |

X1: Connections to the mains supply

X2: Control connections

The control electronics are isolated from the power section by the optocoupler and the power supply transformer. The trigger pulse generation is based on an integrated circuit.

3. Technical Data

Type

1A/2A

Applicable for

- Ohmic load $R_W:R_K \approx 1:1$
- Transformer load (factory setting)

Important information:

The induction of the downstream transformer should not exceed 1.1 T et main voltage.

Operational modes

- Full oscillation cycle TAKT (Type 1A/2A) variable cycle frequency:

Type 1A:

Ohmic load: max $f_N/2$

Transformer load: max 4 Hz at $f_N = 50$ Hz

Type 2A:

Ohmic load: max $f_N/10$

Transformer load: max 4 Hz at $f_N = 50$ Hz

- Phase angle mode VAR (Type 1A)

Control range:

10° ... 175°el.

Setpoint value input	0.4...20 mA, $R_i = 250 \Omega$ 0.1... 5 V, $R_i = 10 \text{ k}\Omega$
Life Zero	Switch S5: start of control $\pm 3.6 \text{ mA}$ $\pm 0.9 \text{ V}$ Potentiometer "Life Zero": Start of control freely adjustable The setpoint value input is isolated from the power supply.
Control options	Cascade voltage control (U_- : rectification value of load voltage)
Accuracy of control	$\pm 5\%$ for supply variations of $\pm 10\%$
Indicators	LED "On" operationally ready
Ambient temperature	- 10°C... + 45°C with self cooling - 10°C... + 35°C with forced fan cooling (1A/2A..280 HF)
Set-up height	$\leq 1000 \text{ m}$ above mean sea level
Operational voltage	Nominal connection voltage U_{RMS} 230/400/500 V other voltages on demand
Permissible deviation in the supply voltage	$\pm 15\%$, which must not result in the standard current being exceeded
Power supply frequency f_N	47..63 Hz
Power consumption for the electronics	Approx. 3 VA
Pulse gate	Load: 8 V/2 mA
Fault signal relay	Terminal block X3, terminals 1,2,3 (master). Fault: 1-3 closed (closed-circuit current principle) Pick-up delay when switching on mains voltage: approx. 0.5 secs. Contact load: AC max. 220 V/5 A DC max. 250 V/5 A At dry circuit: 1..100 mA Important: If safe disconnection from mains power is required, only low safety voltages should be used.
Leakage path	Control electronics – power circuit $\geq 10 \text{ mm}$ Control electronics – cover $\geq 10 \text{ mm}$ Device can be connected to an SELV circuit As per 0160 Tab. 6
Test voltage	Built-in device designed according to: VDE 0160 5.5.1.3 (5/88) VDE 0106 section 100 (3/83) Contamination level 2 as per VDE 0110 section 1 4.2 (01/89).
Conditions of use for device	Surge voltage category \ddot{U}_{III} as per VDE 0160 5.7 (05/88) Signal terminals strip terminal X2: Designed for safe separation up to 500 V device connection voltage as per VDE 0160 5.6 (5/88)

Warning:

To avoid impairing the safe separation, all connected electric circuits must also demonstrate a safe disconnection and the necessary auxiliary voltages must also be safe extra-low voltages.

Model	As per VDE 0558 section 1 conforms extensively to IEC 146.2
Mounting	Vertical
Mechanical construction	Connecting terminals from below.
Remark	Thyro-A type 1A/2A (rated current < 130 A) according to standard for "Component- switches, Industrial Control" (UL-File 135074) from Underwriters Laboratories

4. Modes of operation

The power controller can be operated in those modes of operation indicated in the following overview:

Thyro-A Typ	Full oscillation cycle mode	Phase angle mode
1A	■	■
2A	■	

The mode of operation is set using switch S1. For switch setting see chapter 7.3

5. Set value input

The set value input of the Thyro-A can be matched different setpoint values the switches S4 and S5. The setpoint value can be set via a process controller or an external potentiometre.

5.1 Process controller with current output

The following setting are to be carried out fore matching:

control range: 0.4...20 mA

Thyro-A	Type	1A		—	
	Type	2A Master		2A Slave	
Start of Control	End of Control	S4	S5	S4	S5
0.4	20 mA	1	1	1	1
4	20 mA	1	0	1	0

Factory setting

Life Zero preset

Switch settings: 1 = closed 0 = open

5.2 Process controller with voltage output or external potentiometer

The following settings are to be carried out for matching:

Control range: 0.1 ... 5 V
0.2 ... 10 V (with 10 kΩ dropping resistor)

Thyro-A	Type	1A		—	
	Type	2A Master		2A Slave	
Start of Control	End of Control	S4	S5	S4	S5
0.1	5 V	0	1	1	0
1	5 V	0	0	1	0

Adjustable from factory setting
Life Zero preset

Switch settings: 1 = closed 0 = open

5.3 Potentiometer "Life Zero"

The potentiometer "Life Zero" enables the setting of the start of control to all values within the control range. The potentiometer is accessible without having to remove the cover. The switch S5 modifies the setting of the start of control by a defined step ΔS within the control range.

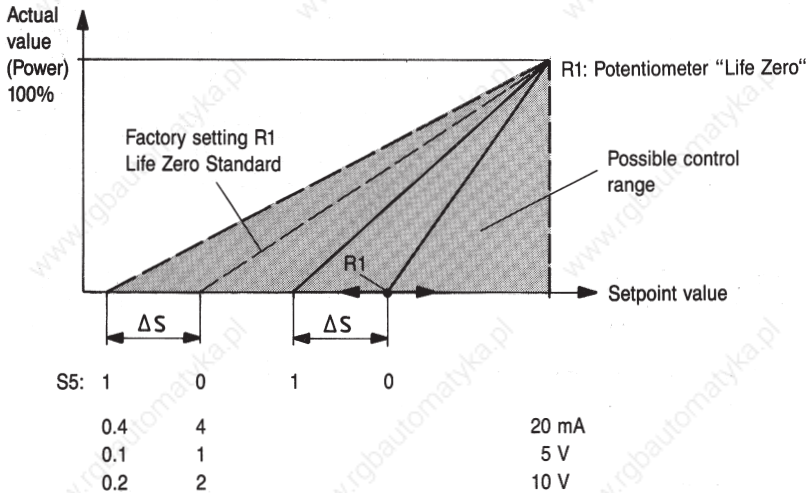

Control characteristics

The voltage control is designed to achieve full modulation at 100% setpoint value and mains over voltage.

6. Notes on installation and connections

6.1 Instructions for installation and connection

Thyro-A type 1A/2A

- are integrated units for industrial use to VDE 0160.
- should be installed in the vertical position.
 - Floor clearance ≥ 100 mm
 - Ceiling clearance ≥ 150 mm
- Sources of heat should not be applied beneath the unit.
- should be installed safe from contact in a switch cabinet.
 - It should be ensured that air can circulate adequately through the cabinet.
- are intended for use in dry buildings only.
 - The interior must be kept free of conductive contamination and corrosive gases.
- must be properly earthed in accordance with the regulations of the local power supply authority.
- It must be possible to disconnect Thyro-1A/2A from the mains power supply (VDE 0160 6.3.1/5.88).
 - To avoid malfunctions, the following instructions for installation should be followed.
- If possible, load and control lines should be laid separately.
- Short, twisted control lines should be used (no loops).
- The unit should be earthed correctly.

Caution:

If it is necessary to open the Thyro-A, it must be disconnected from all sources of voltage before setting the switch or carrying out repair or maintenance work. If this should not be possible, the work should be done only by properly qualified staff who are aware of the danger involved.

The pulse lock must not be used for safety shut-down e.g. for emergency stop, as it cannot be switched off if the thyristor is short circuited. On transformer load **and** separate infeed of control and power units, the Thyro-A must be released via the pulse lock. It can be released only when voltage is applied to the power unit. It must be set before the power unit is free of voltage.

The integrated semiconductor fuses are designed to protect the thyristors from short circuits or high overcurrents of short duration. These are not activated immediately when the rated current is exceeded only slightly. They are therefore not suitable for line protected as stipulated by the VDE regulations.

The 2 A/tr. fuse in the electronics supply line on terminal X1.3 ensures line protection during operation between two phases. At phase against N conductor, this fuse is ineffective.

6.2 Connection diagram

6.2.1 Connection set value input

The set value input can be wired as follows

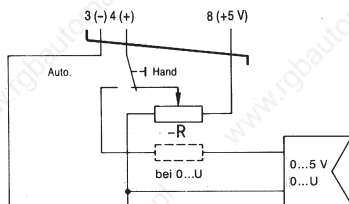
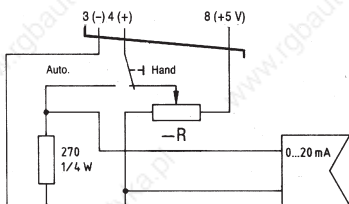
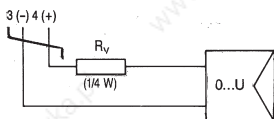
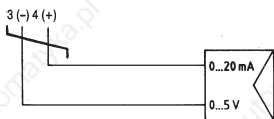
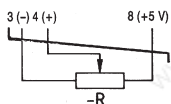
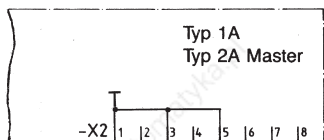

Connection set value input

Set value input

Strip terminal X2

Terminal 3 (-) and 4 (+)

Terminal 8: output + 5 V

External potentiometer

R: max 5 kΩ/0.5 W

Process controller

with current or

voltage output

$U > 5 \text{ V}$

$$R_v = 10 \text{ k}\Omega \cdot \frac{U - 5 \text{ V}}{5 \text{ V}}$$

Combination of external potentiometer and process controller. The set value input on the process controller must be matched to the voltage output.

6.2.2 Connection Type 1A

The Thyro-A is to be connected according to the connection plan. The circuit latch, consisting of K1 and K2, is necessary for the operation mode TAKT with transformer load. Superior switch installation must be covered into the circuit latch.

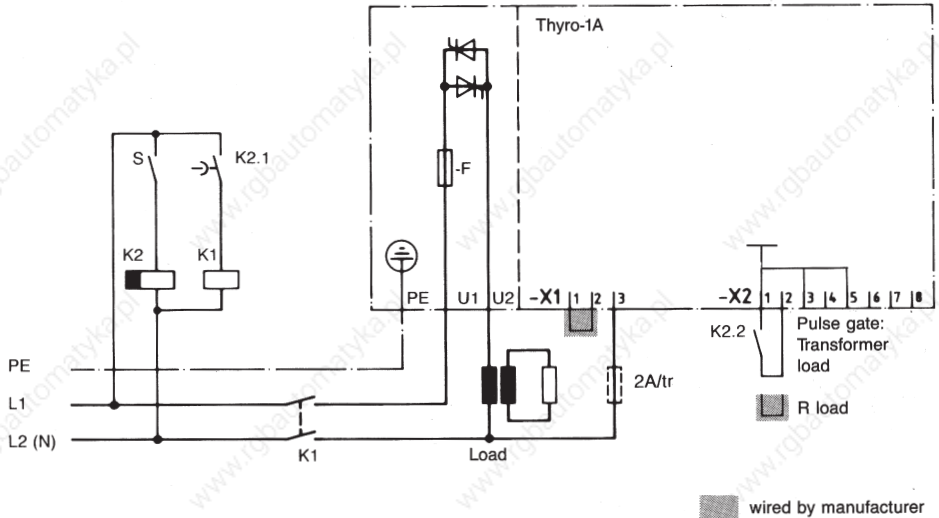

Attention

1A...-280 HF

Connection fuse of fan and fan monitoring please look in section 6.2.4.

Operational modes: TAKT/VAR

Load: ohmic or transformer load

Note:

- K1: Point of separation as per VDE 0160 6.3.1/5.88
- K2: Release delay time lag relay with $t_r \geq 20$ ms
- S: On/off switch

Note: The 2A/tr. fuse serves as line protection only, if Thyro-A type 1A is connected between two phases.

6.2.3 Connection Type 2A

The Thyro-A is to be connected according to the connection plan. The circuit latch, consisting of K1 and K2, is only necessary for transformer load. Superior switch installation must be covered into the circuit latch.

Watch to clock-wise rotating filed!

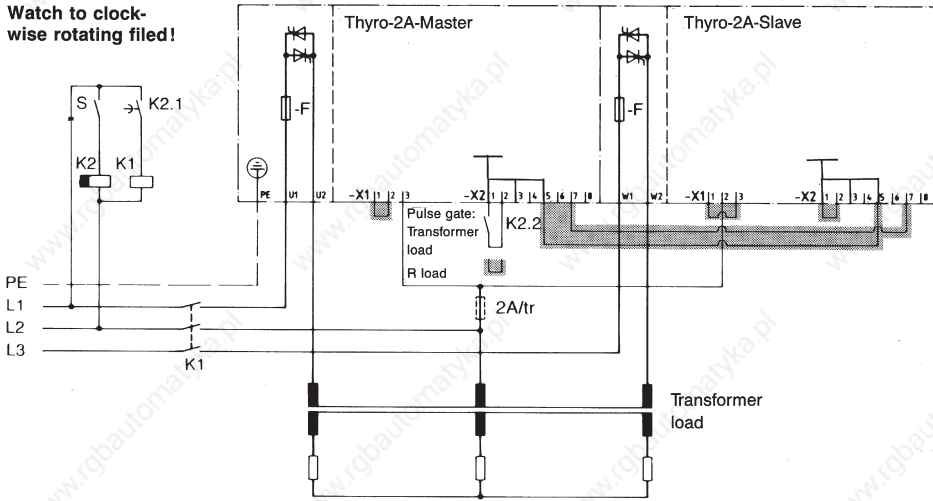

Attention

2A....-280 HF

Fan connection please look in section 6.2.4.

 wired by manufacturer

Operational mode: TAKT

Load:

- ohmic load
- delta connection
- star connection without neutral conductor

Transformer load

- primary: star connection without neutral conductor (recommendation)
- secondary: star or delta connection

downstream load:

- star or delta connection

Note:

K1: Point of separation

as per VDE 0160 6.3.1/5.88

K2: Release delay time lag relay

$t_v \geq 20$ ms

S: On/off switch

Note: The 2A/tr. fuse serves as line protection.

6.2.4 Connection of fan (1A/2A ...-280 HF)

Power controller 1A/2A .. 280 HF are equipped with a fan for forced cooling.

The terminal strip X7 for connection of the fan power supply is mounted separately on the fan. In the table the rated fan currents are listed.

Thyro-A type	rated fan current 50 Hz	rated current 60 Hz
1A...-280 HF	0.12 A	0.11 A
2A...-280 HF	0.25 A	0.23 A

The fan monitoring signalled at overtemperature on the 1A/2A-Master power section about the fault-signal relay terminal strip X3 a fault-signal (terminals 1-3 closed).

The operation of the power controller after fault can be set by switch S7.

Switch S7 closed The power controller switches off after reaching overtemperature.

Attention:

Thyro-A starts automatically after below of overtemperature.

Switch S7 opened The power controller is in operation after overtemperature.

Connection

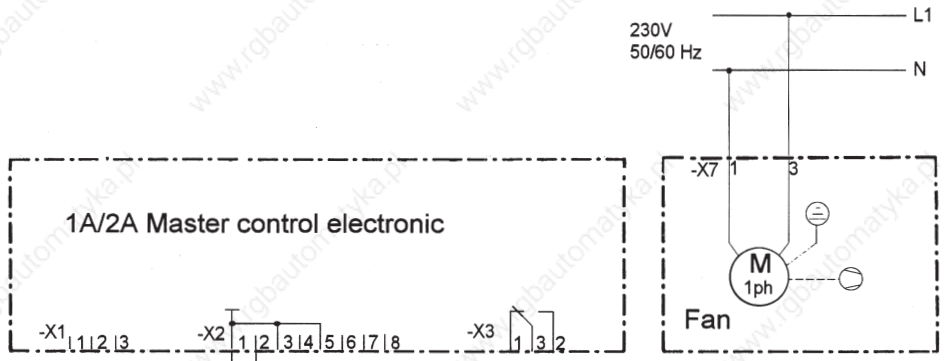

7. Initialisation

7.1 Operational elements (rated current 30..100 A)

In the following diagram, the arrangement of the switches S1-S6 and potentiometer "Life Zero" is shown.

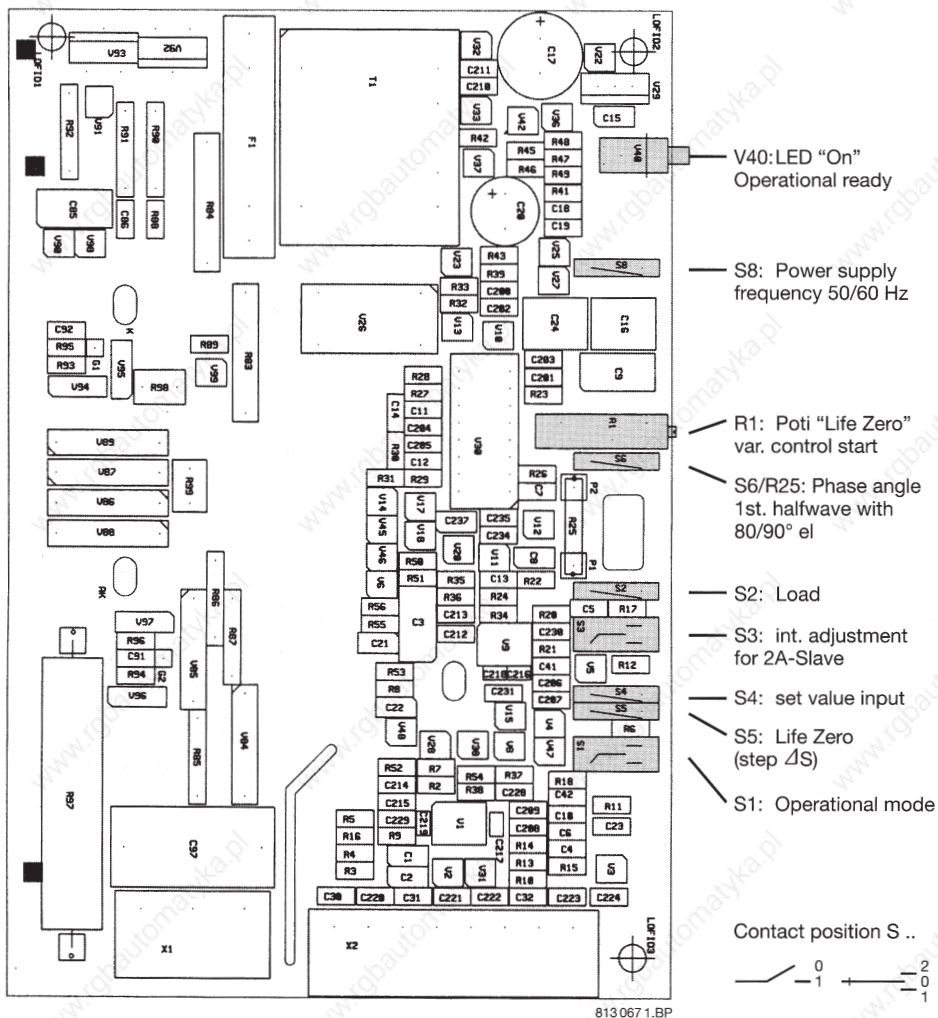

7.2 Operational elements (rated current 130..280 A)

In the following diagram the arrangement of the switches and potentiometer is shown.

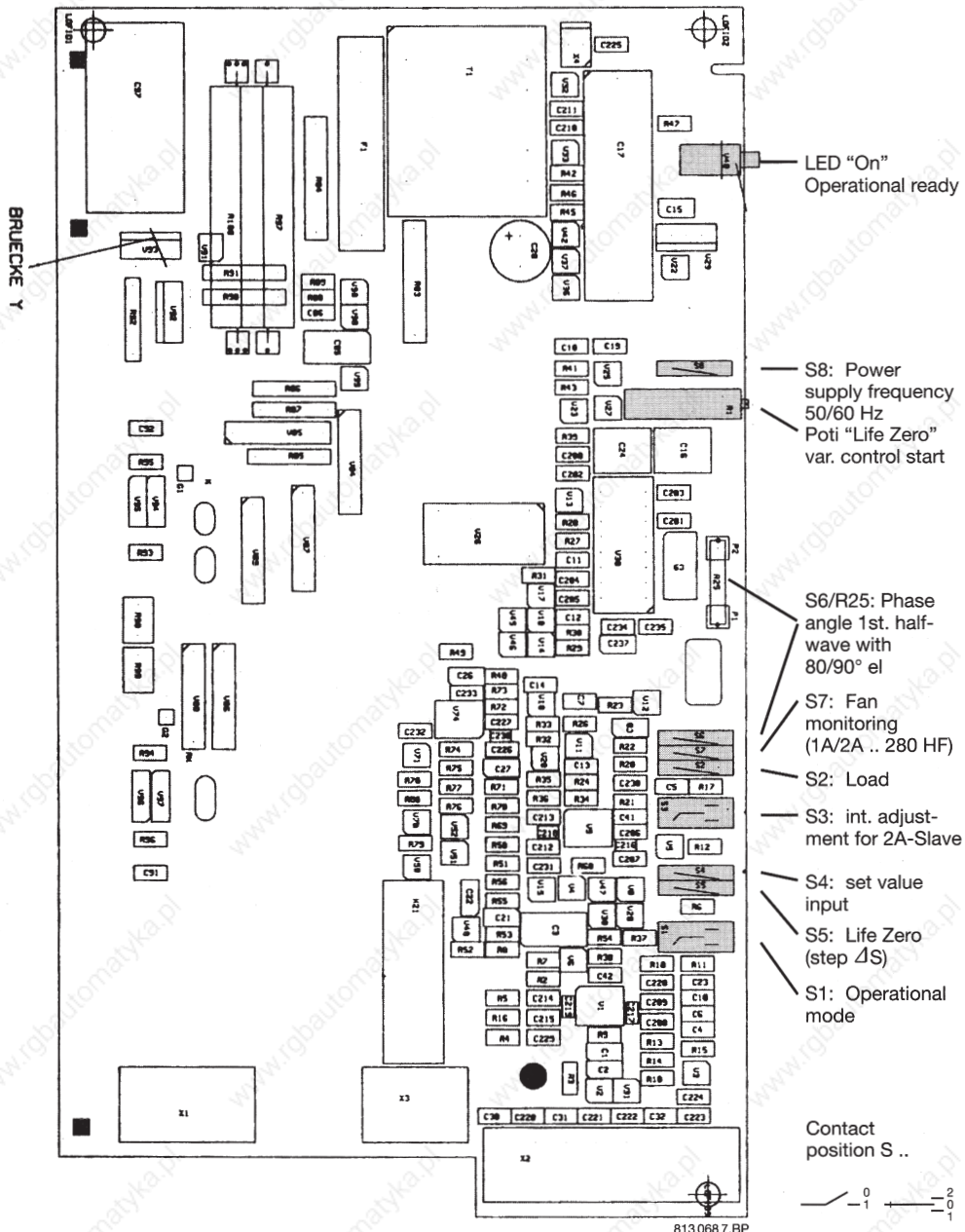

7.3 Switch settings

The switches are to be set as specified in the table after removal of the over in zero voltage operating conditions.

Function	S1	S2	S3	S4	S5	S6	S7	S8
Thyro-A type 1A								
rated current 30..100 A	S1	S2	S3	S4	S5	S6	S7	S8
rated current 130/170 A	S1	S2	S3	S4	S5	S6	S7	S8
rated current 280 A	S1	S2	S3	S4	S5	S6	S7	S8
ohmic load	1	0	1			0		
transformator load	1	1	1			1		
ohmich load	2	0	1			0		
transformator load	2	0	1			0		
Setpoint value				1	1			
0..20 mA				1	1			
4..20 mA				1	0			
0..5 V				0	1			
1..5 V				0	0			
Power supply frequency								1
50 Hz								1
60 Hz								0
Behaviour after overtemperature								0
Thyro-A don't switch off								0
Thyro-A switch off (*)								1

rated current 130/170 A: S7 without function

(*) Attention:

Thyro-A starts automatically after below of overtemperature!

Changeover contact S1, S3 : 1 = position 1, 2 = position 2
Switch S2, S4, S5, S6, S7, S8 : 0 = open, 1 = closed

Table of switch settings

Manufacturer's setting

The switches are to be set as specified in the table after removal of the cover in zero voltage operating conditions.

Function	2A Master								2A Slave							
	S1	S2	S3	S4	S5	S6	S7	S8	S1	S2	S3	S4	S5	S6	S7	S8
Thyro-A type 2A	rated current 30...100 A								— S8							
	rated current 130/170 A								S6 S7 S8							
	rated current 280 A								S6 S7 S8							
Operating mode	ohmic load								0							
TAKT	transformator load								1							
Setpoint value	0...20 mA								1 1							
	4...20 mA								1 0							
	0...5 V								0 1							
	1...5 V								0 0							
Power supply frequency	50 Hz								1							
	60 Hz								0							
Behaviour after overtemperature	Thyro-A don't switch off								0							
	Thyro-A switch off (*)								1							

rated current 130/170 A: S7 without function

(*) Attention:

Thyro-A starts automatically after below of overtemperature!

Changeover contact S1, S3 : 1 = position 1, 2 = position 2
Switch S2, S4, S5, S6, S7, S8 : 0 = open, 1 = closed

7.4 Adjusting the start of control with the “Life Zero” potentiometer

Deviations from the factory adjustment of the start of control can be made over the entire control range using the “Life Zero” potentiometer as follows:

1. Setting the desired control start value at the set value input of the operational power controller.
2. Adjusting the potentiometer must be performed as follows; Switch S5 varies the control start by a defined step (see section 5.3)
 - a) Operational current already available:
The potentiometer “Life Zero” should be adjusted by rotating clockwise until the operational current is zero.
 - b) Operational current not available:
The potentiometer “Life Zero” should be adjusted by rotating counterclockwise until the operational current just begins to flow.

8. Hints on troubleshooting

Should operational errors occur in the power controller, first check the switch settings in conjunction with those in the table in section 7.3.

If the error is still present after this check, the cause may be one of the following:

- a) No current in the load circuit during control
Possible causes:
 - Defective fuse in load circuit
 - Defective fuse in the control electronics
 - Missing set value, process controller defective
 - No power supply for the electronics
There must be a dc voltage of approx. 5V between terminal 3 (–) and 8 (+) on the strip terminal X2 (1A/2A Master)
 - Defective control electronics
 - Loose connections or load resistor has a fault.
- b) Power controller is continuously on fully advanced control
 - Set value continuously on maximum value
 - Defective control electronics
 - Defective thyristor in load circuit
- c) Power controller cannot be advanced
 - Check matching of set value input
 - Supply voltage too high
- d) Fault signal relay reports failure
 - defect of fan?

9. Typenreihe und Ersatzteile

9. Type series and spare parts

Typ Type	Nennleistung Rated power kW	Verlustleistung Power loss W	Thyristor Thyritors	Halbleitersicherung Semiconductor fuse NH-AR. Gr. 00C
1A 230- 30 H	7	47	TT 18 N 800	50 A
1A 230- 45 H	10	48	TT 46 N 800	63 A
1A 230- 60 H	14	80	TT 36 N 800	80 A
1A 230-100 H	23	105	TT 95 N 800	160 A
1A 230-130 H	30	150	TT 105 N 800	200 A
1A 230-170 H	39	210	TT 162 N 800	315 A
1A 230-280 HF	64	330	TT 162 N 800	350 A
1A 400- 30 H	12	47	TT 18 N 1400	50 A
1A 400- 45 H	18	48	TT 46 N 1400	63 A
1A 400- 60 H	24	80	TT 36 N 1400	80 A
1A 400-100 H	40	105	TT 95 N 1400	160 A
1A 400-130 H	52	150	TT 105 N 1400	200 A
1A 400-170 H	68	210	TT 162 N 1400	315 A
1A 400-280 HF	112	330	TT 162 N 1400	350 A
1A 500- 40 H	20	50	TT 31 N 1600	63 A
1A 500- 60 H	30	67	TT 56 N 1600	80 A
1A 500-100 H	50	110	TT 106 N 1600	160 A
1A 500-130 H	65	150	TT 105 N 1600	200 A
1A 500-170 H	85	210	TT 162 N 1600	315 A
1A 500-280 HF	140	330	TT 162 N 1600	350 A
2A 230- 30 H*	12	94	TT 18 N 800	50 A
2A 230- 45 H*	18	96	TT 46 N 800	63 A
2A 230- 60 H*	24	160	TT 36 N 800	80 A
2A 230-100 H*	40	210	TT 95 N 800	160 A
2A 230-130 H*	30	300	TT 105 N 800	200 A
2A 230-170 H*	68	420	TT 162 N 800	315 A
2A 230-280 HF*	112	660	TT 162 N 800	350 A
2A 400- 30 H	21	94	TT 18 N 1400	50 A
2A 400- 45 H	31	96	TT 46 N 1400	63 A
2A 400- 60 H	42	160	TT 36 N 1400	80 A
2A 400-100 H	69	210	TT 95 N 1400	160 A
2A 400-130 H	90	300	TT 105 N 1400	200 A
2A 400-170 H	118	420	TT 162 N 1400	315 A
2A 400-280 HF	194	660	TT 162 N 1400	350 A
2A 500- 40 H	35	100	TT 31 N 1600	63 A
2A 500- 60 H	52	134	TT 56 N 1600	80 A
2A 500-100 H	87	220	TT 106 N 1600	160 A
2A 500-130 H	113	300	TT 105 N 1600	200 A
2A 500-170 H	147	420	TT 162 N 1600	315 A
2A 500-280 HF	243	660	TT 162 N 1600	350 A

Andere Nennanschlußspannung auf Anfrage
Other Nominal voltage on demand

* Auf Anfrage/On demand

Wichtiger Hinweis:

Bei Austausch der Steuerelektronik 2A Slave (Typenstrom 30..170 A) ist der werkseitig eingebaute Widerstand $R_{25} = 4,7 \text{ k}\Omega/0,6 \text{ W}$ gegen $6,8 \text{ k}\Omega/0,6 \text{ W}$ zu ersetzen. Der Widerstand befindet sich auf Lötstützpunkten.

Important:

If the electronic 2A Slave (rated current 30..170 A) has to be replaced, the resistor $R_{25} = 4.7 \text{ k}\Omega/0.6 \text{ W}$ must be changed by $6.8 \text{ k}\Omega/0.6 \text{ W}$. The resistor is on solder pins.

Sicherung der Steuerelektronik: 0,16 A/500 V (5 · 30)

Fuse of control electronic: 0.16 A/500 V (5 · 30)

Achtung!

Thyro-A mit Typenstrom 130..280 A besitzen keine UL-Approbaton.

Attention:

Thyro-A with rated current 130..280 A don't have the UL-Approbaton.

10. Maßbilder
10. Dimensions

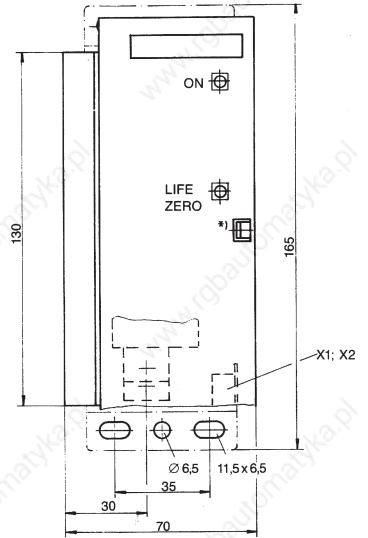
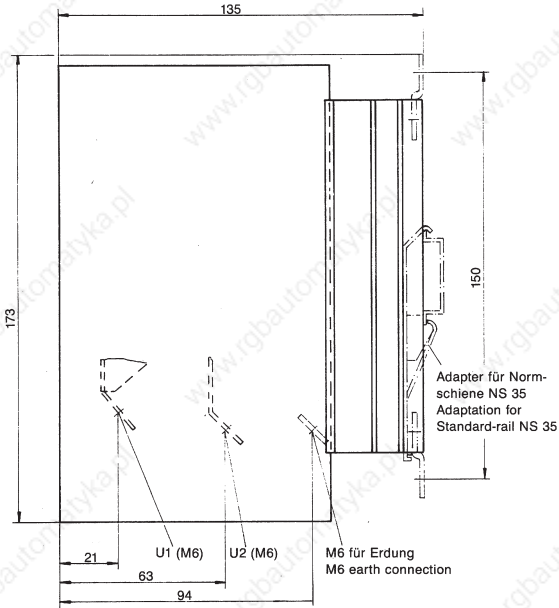

*) Zum Entriegeln Federhaken nach rechts drücken
to open push spring catch to the right

Typ/Type 1A 230/400-30/45 A
1A 500-40 H
Gewicht/weight: 1,0 kg

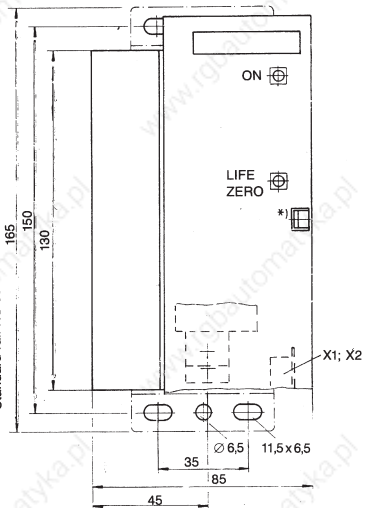
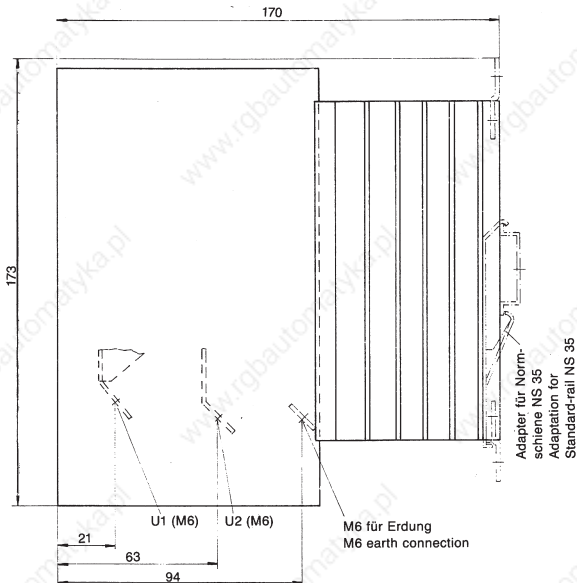

*) Zum Entriegeln Federhaken nach rechts drücken
to open push spring catch to the right

Typ/Type 1A 230/400/500-60/100 H
Gewicht/weight: 1,8 kg

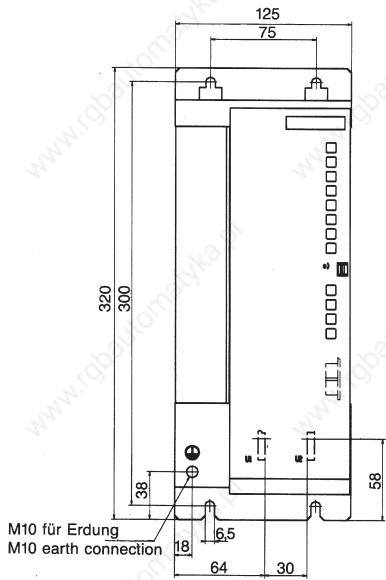

M10 für Erdung
M10 earth connection

Typ/Type 1A 230/400/500-130/170 A
Gewicht/weight: 4,0 kg

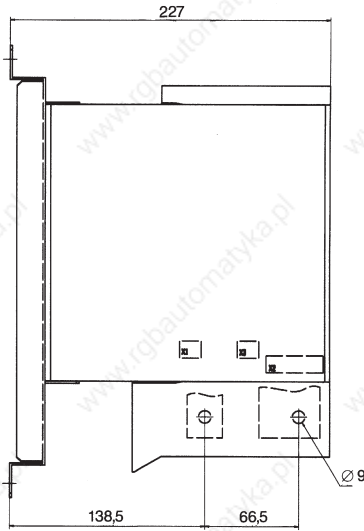

*) Zum Entriegeln Federhaken nach rechts drücken
to open push spring catch to the right

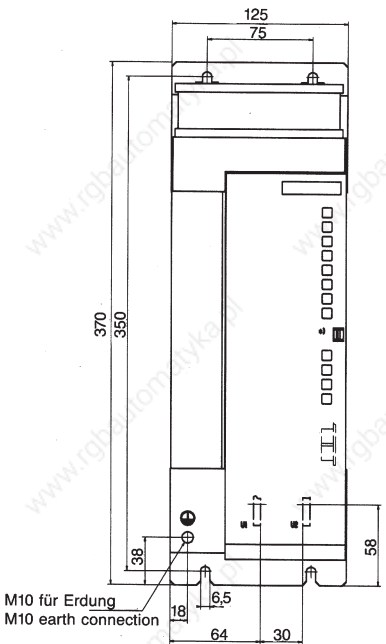

M10 für Erdung
M10 earth connection

Typ/Type 1A 230/400/500-280 HF
Gewicht/weight: 5,0 kg

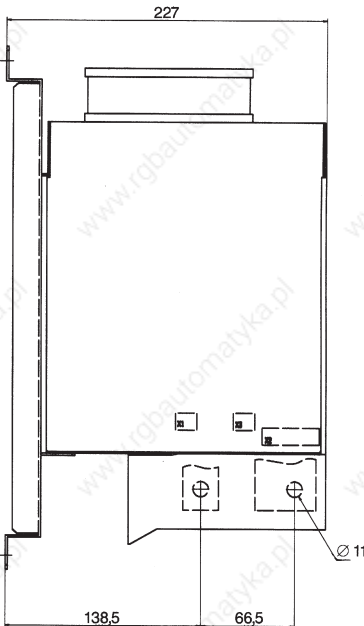

*) Zum Entriegeln Federhaken nach rechts drücken
to open push spring catch to the right

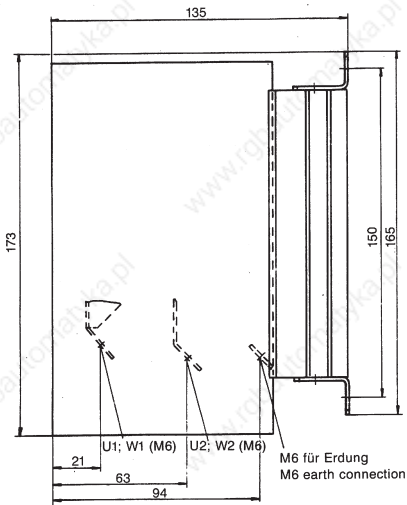

Typ/Type 2A 230/400-30/45 H
 2A 500-40 H
 Gewicht/weight: 2,1 kg

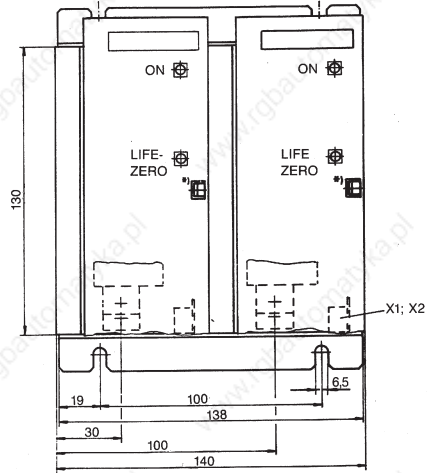

*) Zum Entriegeln Federhaken nach rechts drücken
 to open push spring catch to the right

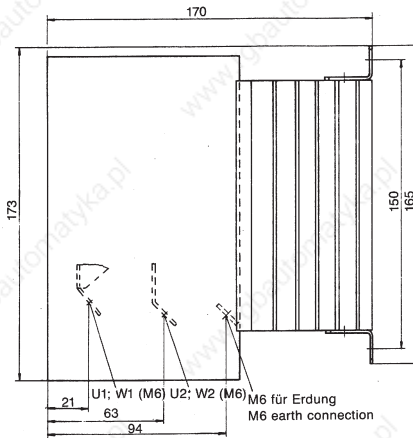

Typ/Type 2A 230/400/500-60/100 H
 Gewicht/weight: 3,7 kg

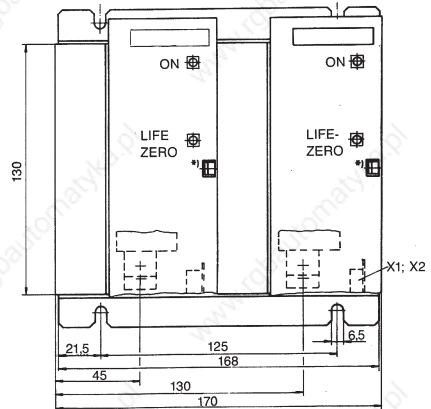

*) Zum Entriegeln Federhaken nach rechts drücken
 to open push spring catch to the right

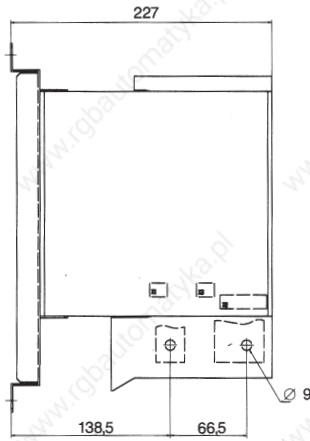
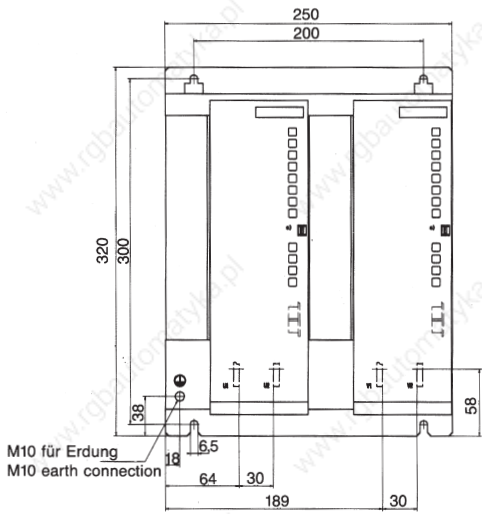

*) Zum Entriegeln Federhaken nach rechts drücken
to open push spring catch to the right

Typ/Type 2A 230/400/500-130/170 A
Gewicht/weight: 8,0 kg

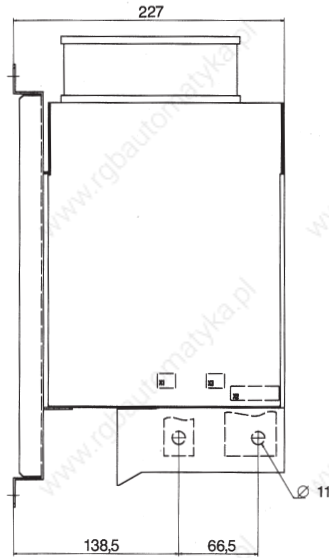
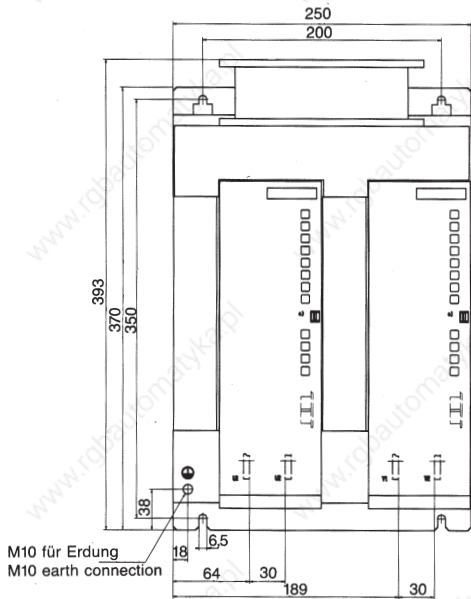

*) Zum Entriegeln Federhaken nach rechts drücken
to open push spring catch to the right

Typ/Type 2A 230/400/500-280 HF
Gewicht/weight: 11,0 kg

11. Nachweis der CE-Konformität

EMV-Richtlinie

Störaussendung:

Folgende Normen werden nach EN 50081-2 (Industriebereich) eingehalten:

Leitungsgebundene Störungen nach EN 55011 Klasse A

In der Betriebsart VAR (Phasenanschnittprinzip) werden die Grenzwerte physikalisch bedingt überschritten.

Abstrahlung nach 55011 Klasse A

Störfestigkeit:

Folgende Normen werden nach EN 50082-2 (Industriebereich) eingehalten:

Gehäuse:

ESD-Test gemäß EN 61000-4-2: 6 kV-Kontakt

8 kV-Luftentladung

HF-Feld (30 MHz-1 GHz) gemäß EN 61000-4-3: 10 V/m

Leistungsleitungen:

Burst-Test gemäß EN 61000-4-4: 2 kV

Surge-Test gemäß pr EN 61000-4-5: 4 kV unsymmetrisch

2 kV symmetrisch

Steuerleitungen:

Burst-Test gemäß EN 61000-4-4: 2 kV

Surge-Test gemäß pr EN 61000-4-5: 2 kV unsymmetrisch

Aufbauhinweise

Damit oben aufgeführte Störfestigkeit gegen HF-Felder erreicht werden, sind analoge Signalleitungen (X2) abzuschirmen. Der Schirm ist in der Nähe des Steckers zu erden.

Niederspannungsrichtlinie

Folgende Normen werden für die elektr. Sicherheit eingehalten:

VDE 0558 Teil 1, pr EN 50178/VDE 0160, VDE 106 Teil 100, VDE 0100 Teil 410, EN 60950

11. Proof of CE-Conformity

EMC-Guideline

Interference generation:

The following EN 50081-2 (industrial) standards are complied with:

Wire-related interference to EN 55011 (class A)

In the operational mode VAR (Phase angle principle) the limiting values will be crossed caused physical.

Radiation to 55011 (class A)

Interference resistance:

The following EN 50082-2 (industrial) standards are complied with:

Housing:

ESD test to EN 61000-4-2: 6 kV contact

8 kV air discharge

HF-field (30 MHz-1 GHz) to EN 61000-4-3: 10 V/m

Power cables:

Burst test to EN 61000-4-4: 2 kV

Surge test to pr EN 61000-4-5: 4 kV unsymmetrical

2 kV symmetrical

Control cables:

Burst test to EN 61000-4-4: 2 kV

Surge test to pr EN 61000-4-5: 2 kV unsymmetrical

Note on installation

To ensure that the interference resistance to HF fields is achieved, analogue signal lines (X2) must be screened. The screen must be earthed close to the plug.

Low-voltage guideline

The following standards are complied with for electrical safety:

VDE 0558 sect. 1, pr EN 50178/VDE 0160, VDE 106 sect. 100, VDE 0100 sect. 410, EN 60950

AEG Stromversorgungs-
Systeme GmbH
Emil-Siepmann-Straße 32
D-59581 Warstein-Belecke
Telefon (0 29 02) 7 63-5 09
Telefax (0 29 02) 7 63-12 01