

Σ -III Series SGM□S/SGDS USER'S MANUAL

For SynqNet Communications

SGMAS/SGMPS/SGMSS/SGMCS Servomotors
SGDS-□□□7□A SERVOPACK



YASKAWA

MANUAL NO. SIEP S800000 25A

SynqNet™ is a registered trademark of the Motion Engineering, Inc. ®

Copyright © 2004 YASKAWA ELECTRIC CORPORATION

All rights reserved. No part of this publication may be reproduced, stored in a retrieval system, or transmitted, in any form, or by any means, mechanical, electronic, photocopying, recording, or otherwise, without the prior written permission of Yaskawa. No patent liability is assumed with respect to the use of the information contained herein. Moreover, because Yaskawa is constantly striving to improve its high-quality products, the information contained in this manual is subject to change without notice. Every precaution has been taken in the preparation of this manual. Nevertheless, Yaskawa assumes no responsibility for errors or omissions. Neither is any liability assumed for damages resulting from the use of the information contained in this publication.

About this Manual

■ Intended Audience

This manual is intended for the following users.

- Those selecting Σ -III Series Servodrives or peripheral devices for Σ -III Series servodrives.
- Those wanting to know about the ratings and characteristics of Σ -III Series servodrives.
- Those designing Σ -III Series servodrive systems.
- Those installing or wiring Σ -III Series servodrives.
- Those performing trial operation or adjustments of Σ -III Series servodrives.
- Those maintaining or inspecting Σ -III Series servodrives.

■ Description of Technical Terms

The terms in this manual are defined as follows:

- Servomotor = Σ -III Series SGMAS, SGMPS, SGMSS, SGMCS (direct drive) servomotor.
- SERVOPACK = Σ -III Series SGDS amplifier.
- Servodrive = A set including a servomotor and servo amplifier.
- Servo System = A servo control system that includes the combination of a servodrive with a host computer and peripheral devices.

■ Indication of Reverse Signals

In this manual, the names of reverse signals (ones that are valid when low) are written with a forward slash (/) before the signal name, as shown in the following example:





- $\overline{\text{S-ON}}$ = /S-ON
- $\overline{\text{P-CON}}$ = /P-CON

■ Outline of the Contents

Chapter	Description
1 Outline	Describes the outline of Σ -III series servodrive.
2 Selections	Describes the models of a servodrive and peripheral devices.
3 SERVOPACK Specifications and Dimensional Drawings	Describes the specifications and dimensional drawings of Σ -III series SERVOPACK.
4 Specifications and Dimensional Drawings of Cables and Peripheral Devices	Describes the specifications and dimensional drawings of cables and peripheral devices.
5 Wiring	Describes wiring after purchase.
6 SynqNet™ Communications	Describes the wiring and communication method of the SynqNet communications.
7 Operation	Describes the operation of the SERVOPACK.
8 Adjustments	Describes the adjustment functions contain autotuning.
9 Inspection, Maintenance, and Troubleshooting	Describes maintenance and inspection contain troubleshooting if an alarm occurs.
10 Appendix	Describes the list of parameters and alarm codes.

■ Visual Aids

The following aids are used to indicate certain types of information for easier reference.

-  • Indicates important information that should be memorized, including precautions such as alarm displays to avoid damaging the devices.
-  • Indicates supplemental information.
-  • Indicates application examples.
-  • Indicates definitions of difficult terms or terms that have not been previously explained in this manual.

Related Manuals

Refer to the following manuals as required.

Manual Name	Manual Number	Contents
Σ -III Series AC SERVOPACK SGDS Safety Precautions	TOBP S800000 00	Describes the safety precautions of Σ -III series SERVOPACK.
Σ -III Series SGM□S/SGDS Digital Operator Operation Manual	TOBP S800000 01	Provides detailed information on the operation of the JUSP-OP05A Digital Operator.

Safety Information

The following conventions are used to indicate precautions in this manual. Failure to heed precautions provided in this manual can result in serious or possibly even fatal injury or damage to the products or to related equipment and systems.



Indicates precautions that, if not heeded, could possibly result in loss of life or serious injury.



Indicates precautions that, if not heeded, could result in relatively serious or minor injury, damage to the product, or faulty operation.

In some situations, the precautions indicated could have serious consequences if not heeded.



Indicates prohibited actions that must not be performed. For example, this symbol would be used to indicate that fire is prohibited as follows: .



Indicates compulsory actions that must be performed. For example, this symbol would be used as follows to indicate that grounding is compulsory: .

The warning symbols for ISO and JIS standards are different, as shown below.

ISO	JIS
	

The ISO symbol is used in this manual.

Both of these symbols appear on warning labels on Yaskawa products. Please abide by these warning labels regardless of which symbol is used.

Notes for Safe Operation

Read this manual thoroughly before checking products on delivery, storage and transportation, installation, wiring, operation and inspection, and disposal of the AC servodrives.

WARNING

- Never touch any rotating motor parts while the motor is running.
Failure to observe this warning may result in injury.
- Before starting operation with a machine connected, make sure that an emergency stop can be applied at any time.
Failure to observe this warning may result in injury.
- Never touch the inside of the SERVOPACKs.
Failure to observe this warning may result in electric shock.
- Do not remove the panel cover while the power is ON.
Failure to observe this warning may result in electric shock.
- Do not touch terminals for five minutes after the power is turned OFF.
Residual voltage may cause electric shock.
- Do not touch terminals for five minutes after voltage resistance test.
Residual voltage may cause electric shock.
- Follow the procedures and instructions for trial operation precisely as noted in the Σ -III series User's Manual (Manual No.: SIEP S800000 00).
Malfunctions that occur after the servomotor is connected to the equipment not only damage the equipment, but may also cause an accident resulting in death or injury.
- The output range of multi-turn data for Σ -III series absolute detection system differs from that for conventional systems (15-bit encoder and 12-bit encoder). Especially when "Infinite length positioning system" of conventional type is to be configured with Σ -III series, be sure to make the system modification.
- The multi-turn limit value must be changed only for special applications.
Changing it inappropriately or unintentionally can be dangerous.
- If the Multi-turn Limit Disagreement alarm occurs, check the setting of parameter Pn205 in the SERVOPACK to be sure that it is correct.
If Fn013 is executed when an incorrect value is set in Pn205, an incorrect value will be set in the encoder. The alarm will disappear even if an incorrect value is set, but incorrect positions will be detected, resulting in a dangerous situation where the machine will move to unexpected positions.
- Do not remove the front cover, cables, connectors, or optional items while the power is ON.
Failure to observe this warning may result in electric shock.
- Installation, disassembly, or repair must be performed only by authorized personnel.
Failure to observe this warning may result in electric shock or injury.
- Do not damage, press, exert excessive force or place heavy objects on the cables.
Failure to observe this warning may result in electric shock, stopping operation of the product, or burning.
- Provide an appropriate stopping device on the machine side to ensure safety. A holding brake for a servomotor with brake is not a stopping device for ensuring safety.
Failure to observe this warning may result in injury.

WARNING

- Do not come close to the machine immediately after resetting momentary power loss to avoid an unexpected restart. Take appropriate measures to ensure safety against an unexpected restart. Failure to observe this warning may result in injury.



- Do not modify the product. Failure to observe this warning may result in injury or damage to the product.



- Connect the ground terminal to electrical codes (ground resistance: 100 W or less). Improper grounding may result in electric shock or fire.

■ Checking on Delivery

CAUTION

- Always use the servomotor and SERVOPACK in one of the specified combinations. Failure to observe this caution may result in fire or malfunction.

■ Storage and Transportation

CAUTION

- Do not store or install the product in the following places. Failure to observe this caution may result in fire, electric shock, or damage to the product.
 - Locations subject to direct sunlight.
 - Locations subject to temperatures outside the range specified in the storage or installation temperature conditions.
 - Locations subject to humidity outside the range specified in the storage or installation humidity conditions.
 - Locations subject to condensation as the result of extreme changes in temperature.
 - Locations subject to corrosive or flammable gases.
 - Locations subject to dust, salts, or iron dust.
 - Locations subject to exposure to water, oil, or chemicals.
 - Locations subject to shock or vibration.
- Do not hold the product by the cables or motor shaft while transporting it. Failure to observe this caution may result in injury or malfunction.
- Do not place any load exceeding the limit specified on the packing box. Failure to observe this caution may result in injury or malfunction.

■ Installation

 CAUTION

- Never use the products in an environment subject to water, corrosive gases, inflammable gases, or combustibles.
Failure to observe this caution may result in electric shock or fire.
- Do not step on or place a heavy object on the product.
Failure to observe this caution may result in injury.
- Do not cover the inlet or outlet ports and prevent any foreign objects from entering the product.
Failure to observe this caution may cause internal elements to deteriorate resulting in malfunction or fire.
- Be sure to install the product in the correct direction.
Failure to observe this caution may result in malfunction.
- Provide the specified clearances between the SERVOPACK and the control panel or with other devices.
Failure to observe this caution may result in fire or malfunction.
- Do not apply any strong impact.
Failure to observe this caution may result in malfunction.

■ Wiring

CAUTION

- Do not connect a three-phase power supply to the U, V, or W output terminals.
Failure to observe this caution may result in injury or fire.
- Securely connect the power supply terminal screws and motor output terminal screws.
Failure to observe this caution may result in fire.
- Do not bundle or run power and signal lines together in the same duct. Keep power and signal lines separated by at least 30 cm (11.81 in).
- Use twisted-pair shielded wires or multi-core twisted pair shielded wires for signal and encoder (PG) feedback lines.
The maximum length is 3 m (118.11 in) for reference input lines and is 20 m (787.40 in) for PG feedback lines.
- Do not touch the power terminals for five minutes after turning power OFF because high voltage may still remain in the SERVOPACK.
Make sure the charge indicator is out first before starting an inspection.
- Avoid frequently turning power ON and OFF. Do not turn power ON or OFF more than once per minute.
Since the SERVOPACK has a capacitor in the power supply, a high charging current flows for 0.2 seconds when power is turned ON. Frequently turning power ON and OFF causes main power devices like capacitors and fuses to deteriorate, resulting in unexpected problems.
- Observe the following precautions when wiring main circuit terminal blocks.
 - Remove the terminal block from the SERVOPACK prior to wiring.
 - Insert only one wire per terminal on the terminal block.
 - Make sure that the core wire is not electrically shorted to adjacent core wires.
- Do not connect the SERVOPACK for 100 V and 200 V directly to a voltage of 400 V.
The SERVOPACK will be destroyed.
- Install the battery at either the host controller or the battery case of the encoder.
It is dangerous to install batteries at both simultaneously, because that sets up a loop circuit between the batteries.
- Be sure to wire correctly and securely.
Failure to observe this caution may result in motor overrun, injury, or malfunction.
- Always use the specified power supply voltage.
An incorrect voltage may result in burning.
- Take appropriate measures to ensure that the input power supply is supplied within the specified voltage fluctuation range. Be particularly careful in places where the power supply is unstable.
An incorrect power supply may result in damage to the product.
- Install external breakers or other safety devices against short-circuiting in external wiring.
Failure to observe this caution may result in fire.

CAUTION

- Take appropriate and sufficient countermeasures for each when installing systems in the following locations.

Failure to observe this caution may result in damage to the product.

- Locations subject to static electricity or other forms of noise.
 - Locations subject to strong electromagnetic fields and magnetic fields.
 - Locations subject to possible exposure to radioactivity.
 - Locations close to power supplies.
- Do not reverse the polarity of the battery when connecting it.
Failure to observe this caution may damage the battery or cause it to explode.

■ Operation

CAUTION

- Conduct trial operation on the servomotor alone with the motor shaft disconnected from machine to avoid any unexpected accidents.

Failure to observe this caution may result in injury.

- Before starting operation with a machine connected, change the settings to match the parameters of the machine.

Starting operation without matching the proper settings may cause the machine to run out of control or malfunction.

- When using the servomotor for a vertical axis, install the safety devices to prevent workpieces to fall off due to occurrence of alarm or overtravel. Set the servomotor so that it will stop in the zero clamp state at occurrence of overtravel.

Failure to observe this caution may cause workpieces to fall off due to overtravel.

- Set to the correct moment of inertia ratio.

Setting to an incorrect moment of inertia ratio may cause vibration.

- Do not touch the SERVOPACK heatsinks, regenerative resistor, or servomotor while power is ON or soon after the power is turned OFF.

Failure to observe this caution may result in burns due to high temperatures.

- Do not make any extreme adjustments or setting changes of parameters.

Failure to observe this caution may result in injury due to unstable operation.

- When an alarm occurs, remove the cause, reset the alarm after confirming safety, and then resume operation.

Failure to observe this caution may result in injury.

- Do not use the servo brake of the servomotor for ordinary braking.

Failure to observe this caution may result in malfunction.

■ Maintenance and Inspection

CAUTION

- When replacing the SERVOPACK, resume operation only after transferring the previous SERVOPACK parameters to the new SERVOPACK.
Failure to observe this caution may result in damage to the product.
- Do not attempt to change wiring while the power is ON.
Failure to observe this caution may result in electric shock or injury.
- Do not disassemble the servomotor.
Failure to observe this caution may result in electric shock or injury.



■ Disposal

CAUTION

- When disposing of the products, treat them as general industrial waste.

■ General Precautions

Note the following to ensure safe application.

- The drawings presented in this manual are sometimes shown without covers or protective guards. Always replace the cover or protective guard as specified first, and then operate the products in accordance with the manual.
- The drawings presented in this manual are typical examples and may not match the product you received.
- This manual is subject to change due to product improvement, specification modification, and manual improvement. When this manual is revised, the manual code is updated and the new manual is published as a next edition.
- If the manual must be ordered due to loss or damage, inform your nearest Yaskawa representative or one of the offices listed on the back of this manual.
- Yaskawa will not take responsibility for the results of unauthorized modifications of this product. Yaskawa shall not be liable for any damages or troubles resulting from unauthorized modification.

CONTENTS

About this Manual	iii
Related Manuals	iv
Safety Information	v
Notes for Safe Operation	vi

1 Outline

1.1 Checking Products	1-2
1.1.1 Check Items	1-2
1.1.2 Servomotors	1-2
1.1.3 SERVOPACKs	1-3
1.2 Product Part Names	1-4
1.2.1 Servomotors	1-4
1.2.2 SERVOPACKs	1-5
1.3 Examples of Servo System Configurations	1-6
1.4 Applicable Standards	1-11
1.4.1 North American Safety Standards (UL, CSA)	1-11
1.4.2 CE Marking	1-11

2 Selections

2.1 Servomotor Model Designations	2-2
2.1.1 Model SGMAS/SGMPS/SGMSS	2-2
2.1.2 Model SGMCS	2-4
2.2 SERVOPACK Model Designations	2-5
2.3 Σ -III Series SERVOPACKs and Applicable Servomotors	2-6
2.4 Selecting Cables	2-7
2.4.1 Cables for SGMAS and SGMPS Servomotor	2-7
2.4.2 Cables for SGMSS Servomotor	2-15
2.4.3 Cables for SGMCS Servomotor	2-20
2.5 Selecting Peripheral Devices	2-24
2.5.1 Special Options	2-24
2.5.2 Molded-case Circuit Breaker and Fuse Capacity	2-25
2.5.3 Noise Filters	2-26
2.5.4 Regenerative Resistors	2-27

3 SERVOPACK Specifications and Dimensional Drawings

3.1 SERVOPACK Ratings and Specifications	3-2
3.2 SERVOPACK Installation	3-4
3.3 SERVOPACK Internal Block Diagrams	3-6
3.3.1 Single-phase 100 V, 50 W to 400 W Models	3-6

3.3.2	Single-phase 200 V, 50 W to 400W Models	3-7
3.3.3	Three-phase 200 V, 1.0 kW Models	3-8
3.3.4	Single-phase 200 V, 750 W Model	3-9
3.3.5	Three-phase 200 V, 1.5 kW to 3.0 kW Models	3-10
3.4	SERVOPACK Power Losses	3-11
3.5	SERVOPACK Overload Characteristics and Load Moment of Inertia	3-12
3.5.1	Overload Characteristics	3-12
3.5.2	Starting and Stopping Time	3-13
3.5.3	Load Moment of Inertia	3-13
3.6	Dimensional Drawings of SERVOPACK Model	
	SGDS-□□□72□	3-17
3.6.1	Classification table	3-17
3.6.2	Single-phase 100 V/200 V, 50 W/100 W/200 W	3-17
3.6.3	Single-phase 200 V, 400 W	3-18
3.6.4	Single-phase 100 V, 400 W	3-18
3.6.5	Single-phase 200 V, 750 W, and Three-phase 200 V, 1.0 kW	3-19
3.6.6	Three-phase 200 V, 1.5 kW	3-19
3.6.7	Three-phase 200 V, 2.0 kW / 3.0 kW	3-20
4	Specifications and Dimensional Drawings of Cables and Peripheral Devices	
4.1	SERVOPACK Main Circuit Wire Size	4-2
4.2	Connectors for Main Circuit, Control Power Supply, and Servomotor Cable	4-4
4.2.1	Spring Type (Standard)	4-4
4.2.2	Crimp Type (Option)	4-5
4.3	CN1 Cables for I/O Signals	4-6
4.3.1	Standard Cables	4-6
4.3.2	Connector Type and Cable Size	4-6
4.4	Peripheral Devices	4-8
4.4.1	Cables for Connecting Personal Computers	4-8
4.4.2	Digital Operator	4-8
4.4.3	Cables for Analog Monitor	4-8
4.4.4	Connector Terminal Block Converter Unit	4-9
4.4.5	Brake Power Supply Unit	4-10
4.4.6	External Regenerative Resistor	4-11
4.4.7	Absolute Encoder Battery	4-13
4.4.8	Molded-case Circuit Breaker (MCCB)	4-14
4.4.9	Noise Filter	4-15
4.4.10	Magnetic Contactor	4-18
4.4.11	Surge Protector	4-20
4.4.12	AC/DC Reactors for Harmonic Suppression	4-21

5	Wiring	
5.1	Wiring Main Circuit	5-2
5.1.1	Names and Descriptions of Main Circuit Terminals	5-2
5.1.2	Wiring Main Circuit Terminal Block (Spring Type)	5-3
5.1.3	Typical Main Circuit Wiring Examples	5-4
5.2	Wiring Encoders	5-7
5.3	Examples of I/O Signal Connections	5-8
5.3.1	Connection Example	5-8
5.3.2	I/O Signal Connector (CN1) Terminal Layout	5-9
5.3.3	I/O Signal (CN1) Names and Functions	5-10
5.3.4	SynqNet Connectors (CN6A and CN6B)	5-11
5.4	Special Wiring	5-12
5.4.1	Wiring Precautions	5-12
5.4.2	Wiring for Noise Control	5-13
5.4.3	Using More Than One SERVOPACK	5-17
5.4.4	400-V Power Supply Voltage	5-18
5.4.5	AC/DC Reactor for Harmonic Suppression	5-19
5.5	Connecting Regenerative Resistors	5-20
5.5.1	Regenerative Power and Regenerative Resistance	5-20
5.5.2	Connecting External Regenerative Resistors	5-20
5.6	Flexible Cables	5-23
6	SynqNet™ Communications	
6.1	Introduction	6-2
6.1.1	Overview	6-2
6.1.2	SynqNet Packet Timing	6-2
6.2	Specifications and Configurations	6-4
6.2.1	Specifications	6-4
6.2.2	SynqNet Communications Connection Example	6-4
6.2.3	Precautions for Wiring SynqNet Cables	6-5
6.2.4	Grounding	6-7
6.3	Settings	6-8
6.3.1	Switch ID Setting	6-8
6.3.2	SynqNet Port LED Indicators	6-8
6.3.3	LED 7-Segment Display	6-9
6.4	Supported SynqNet Features	6-10
6.4.1	Cyclic Commands	6-10
6.4.2	Cyclic Responses	6-10
6.4.3	Service Commands	6-11
7	Operation	
7.1	Trial Operation	7-2
7.1.1	Digital Operator Operation	7-2

8 Adjustments

8.1 Torque Filters	8-2
8.2 Analog Monitor	8-5

9 Inspection, Maintenance, and Troubleshooting

9.1 Troubleshooting	9-2
9.1.1 Alarm Display Table	9-2
9.1.2 Warning Displays	9-4
9.1.3 Troubleshooting of Alarm and Warning	9-5
9.1.4 Troubleshooting for Malfunction without Alarm Display	9-17
9.2 Inspection and Maintenance	9-21
9.2.1 Servomotor Inspection	9-21
9.2.2 SERVOPACK Inspection	9-21
9.2.3 SERVOPACK's Parts Replacement Schedule	9-22

10 Appendix

10.1 Utility Functions	10-2
10.1.1 List of Parameters	10-3
10.2 Monitor Modes	10-10

INDEX

Revision History



Outline

- 1.1 Checking Products ----- 1-2
 - 1.1.1 Check Items ----- 1-2
 - 1.1.2 Servomotors ----- 1-2
 - 1.1.3 SERVOPACKs ----- 1-3
- 1.2 Product Part Names ----- 1-4
 - 1.2.1 Servomotors ----- 1-4
 - 1.2.2 SERVOPACKs ----- 1-5
- 1.3 Examples of Servo System Configurations ----- 1-6
- 1.4 Applicable Standards ----- 1-11
 - 1.4.1 North American Safety Standards (UL, CSA) ----- 1-11
 - 1.4.2 CE Marking ----- 1-11

1.1 Checking Products

The following procedure is used to check the AC servodrives of Σ -III Series products on delivery.

1.1.1 Check Items

Check the following items when Σ -III Series products are delivered.

Check Items	Comments
Are the delivered products the ones that were ordered?	Check the model numbers marked on the nameplates on the servomotor and SERVOPACK. (Refer to the descriptions of model numbers in the following section.)
Does the servomotor shaft rotate smoothly?	The servomotor shaft is normal if it can be turned smoothly by hand. servomotors with brakes, however, cannot be turned manually.
Is there any damage?	Check the overall appearance, and check for damage or scratches that may have occurred during shipping.

If any of the above items are faulty or incorrect, contact your Yaskawa representative or the dealer from whom you purchased the products.

1.1.2 Servomotors

(1) Types SGMAS and SGMPS

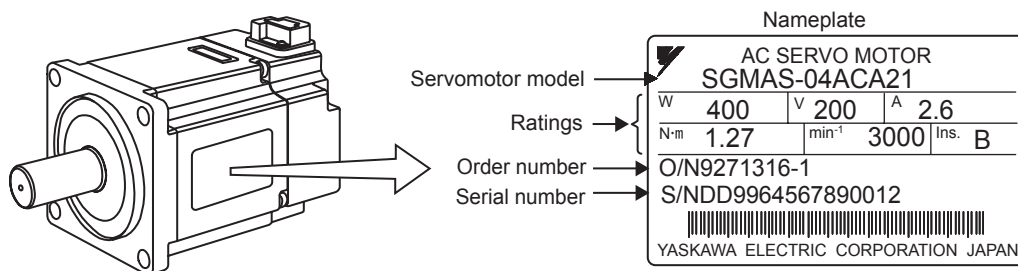

(2) Type SGMSS

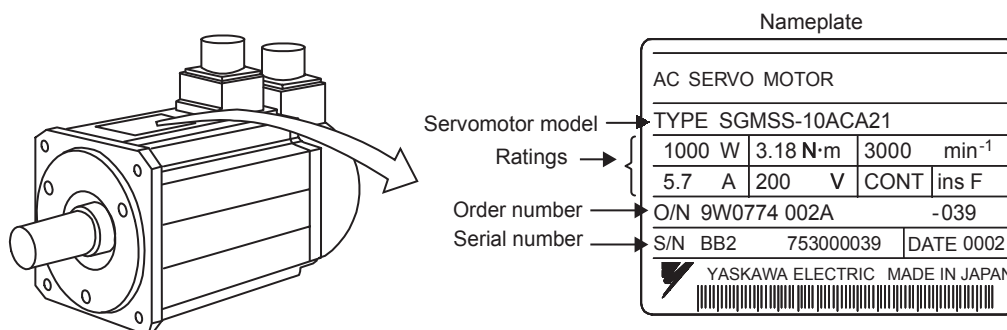

(3) Type SGMCS Direct-drive (Small-capacity Series)

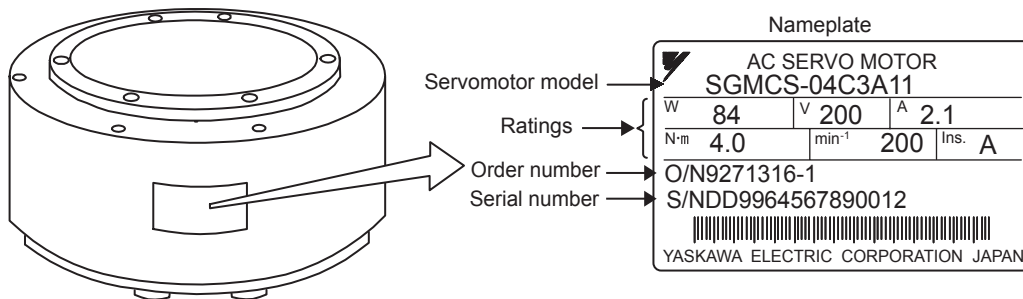

(4) Type SGMCS Direct-drive (Middle-capacity Series)

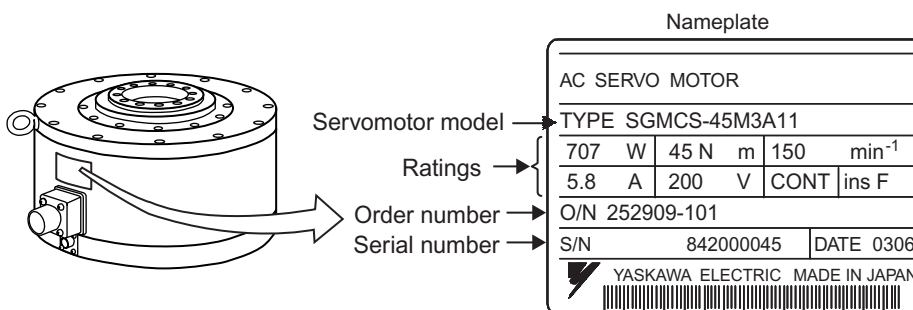

1.1.3 SERVOPACKs

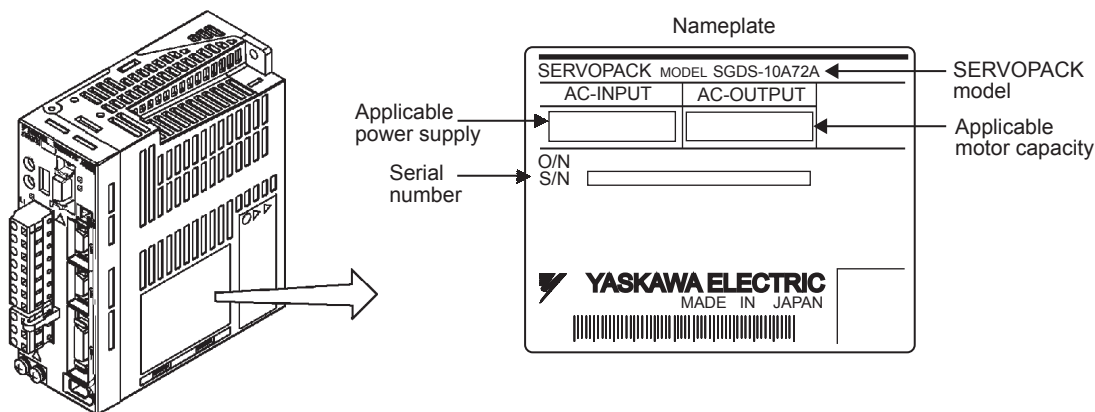

1.2 Product Part Names

1.2.1 Servomotors

(1) Types SGMAS and SGMP5 without Gears and Brakes

SGMAS or SGMP5-01 to 04 for 100 W to 400 W

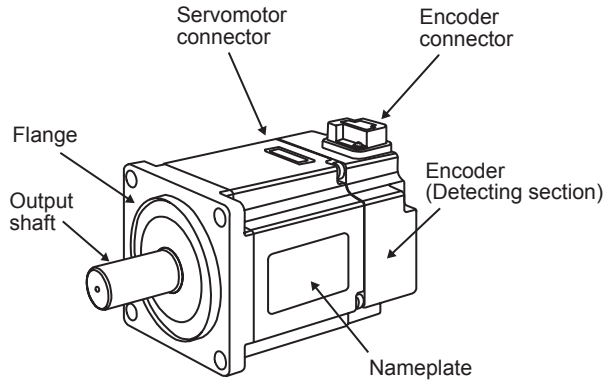

SGMP5-08, 15 for 750 W, 1.5 kW

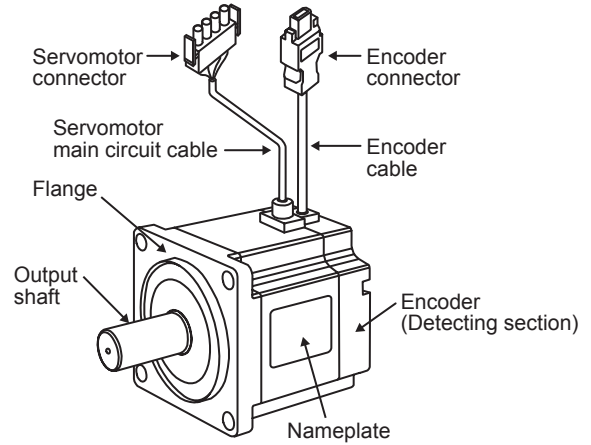

(2) Type SGMSS without Gears and Brakes

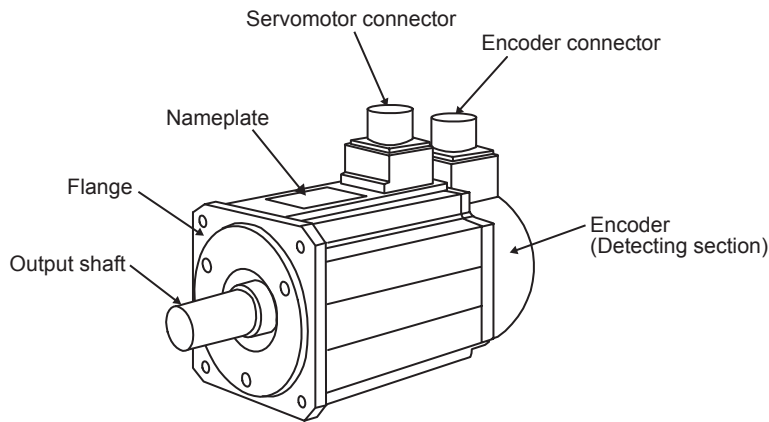

(3) Type SGMCS Direct-drive (Small-capacity Series)

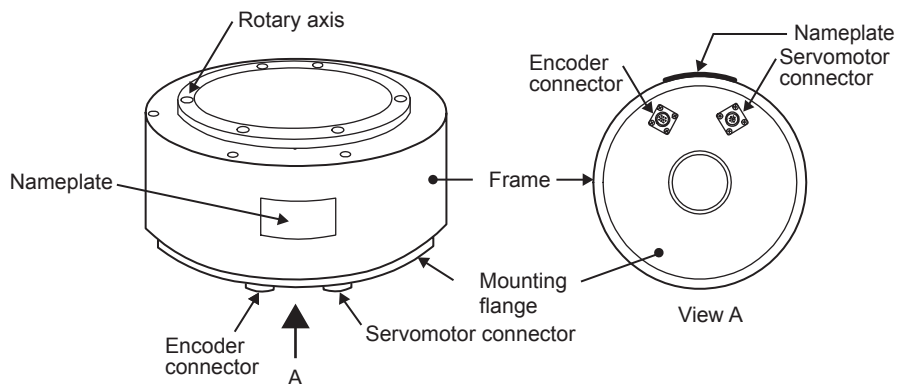

(4) Type SGMCS Direct-drive (Medium-capacity Series)

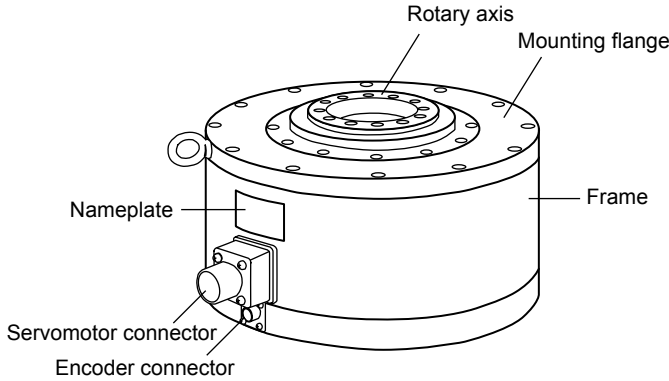

1

1.2.2 SERVOPACKs

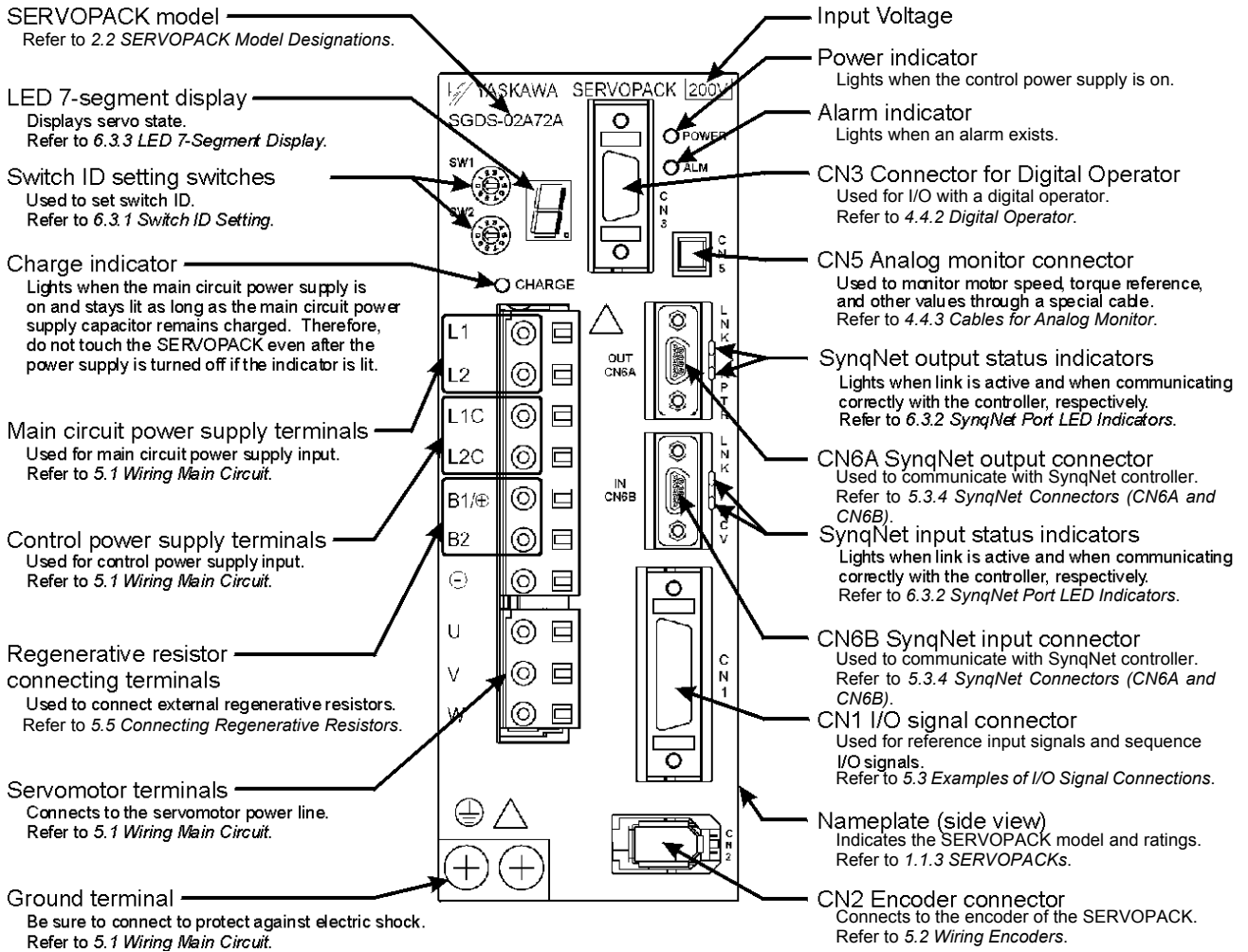

■ Connecting terminal

For connecting a reactor, refer to 5.4.5 *AC/DC Reactor for Harmonic Suppression*.

1.3 Examples of Servo System Configurations

This section describes examples of basic servo system configuration.

(1) Connecting to SGMAS and SGMP5 Servomotors

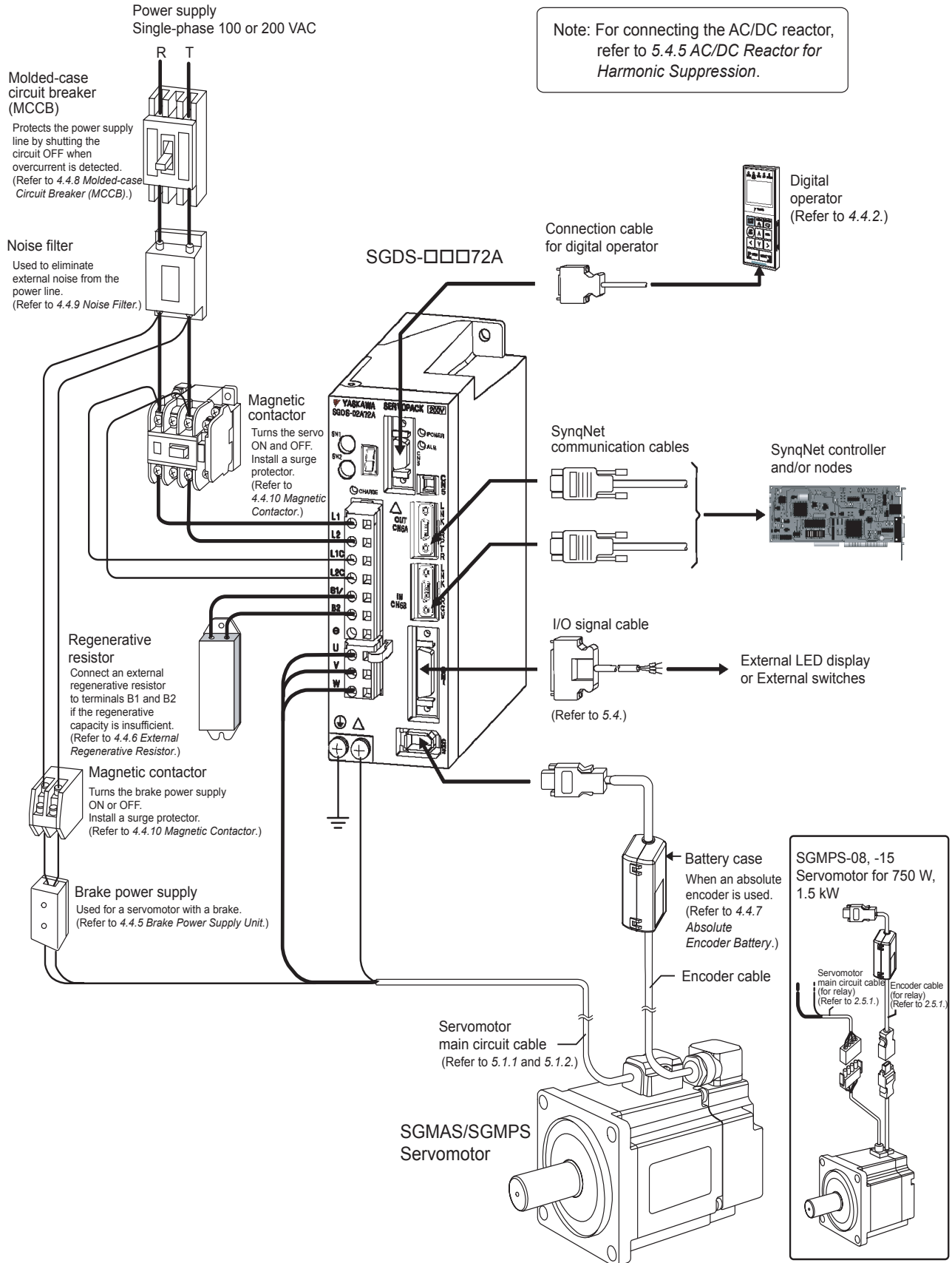

(2) Connecting to SGMAS and SGMP5 Servomotors

Connect the main circuit cable and encoder cable to SGMAS or SGMP5 (100 W to 400 W) servomotor in the following manner.

IMPORTANT

Do not directly touch the connector pins provided with the servomotor. Particularly, the encoder may be damaged by static electricity, etc.

1. Remove the protective tape and cap from the servomotor connector.

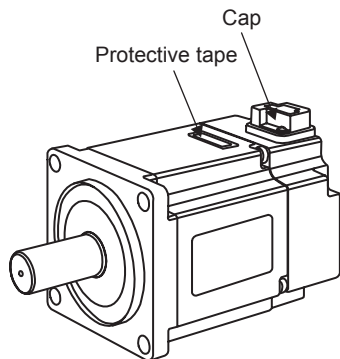

2. Mount the cable connector on the servomotor and fix it with screws as shown in the figure below.

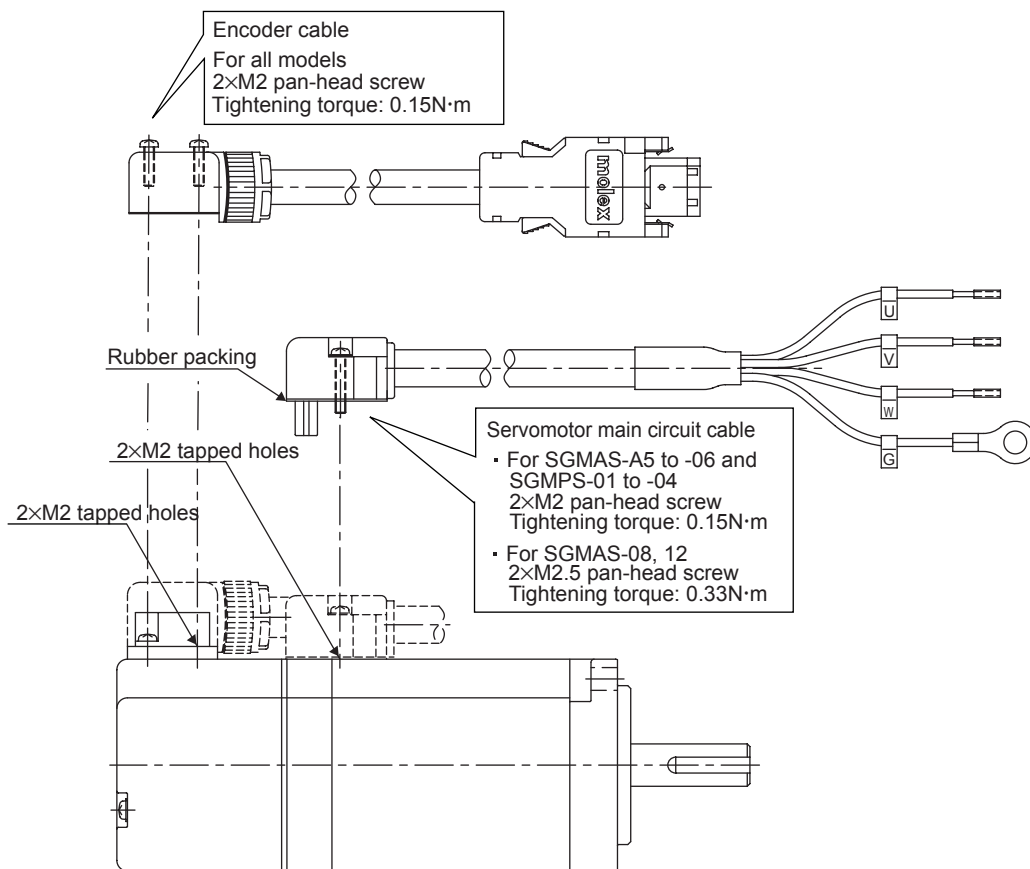

Note: Do not remove the rubber packing on the servomotor-end cable connector. Mount the connector so that the rubber packing is seated properly.

If the rubber packing is not seated properly, the requirements for the protective construction specifications may not be met.

(3) Connecting to SGMSS Servomotors

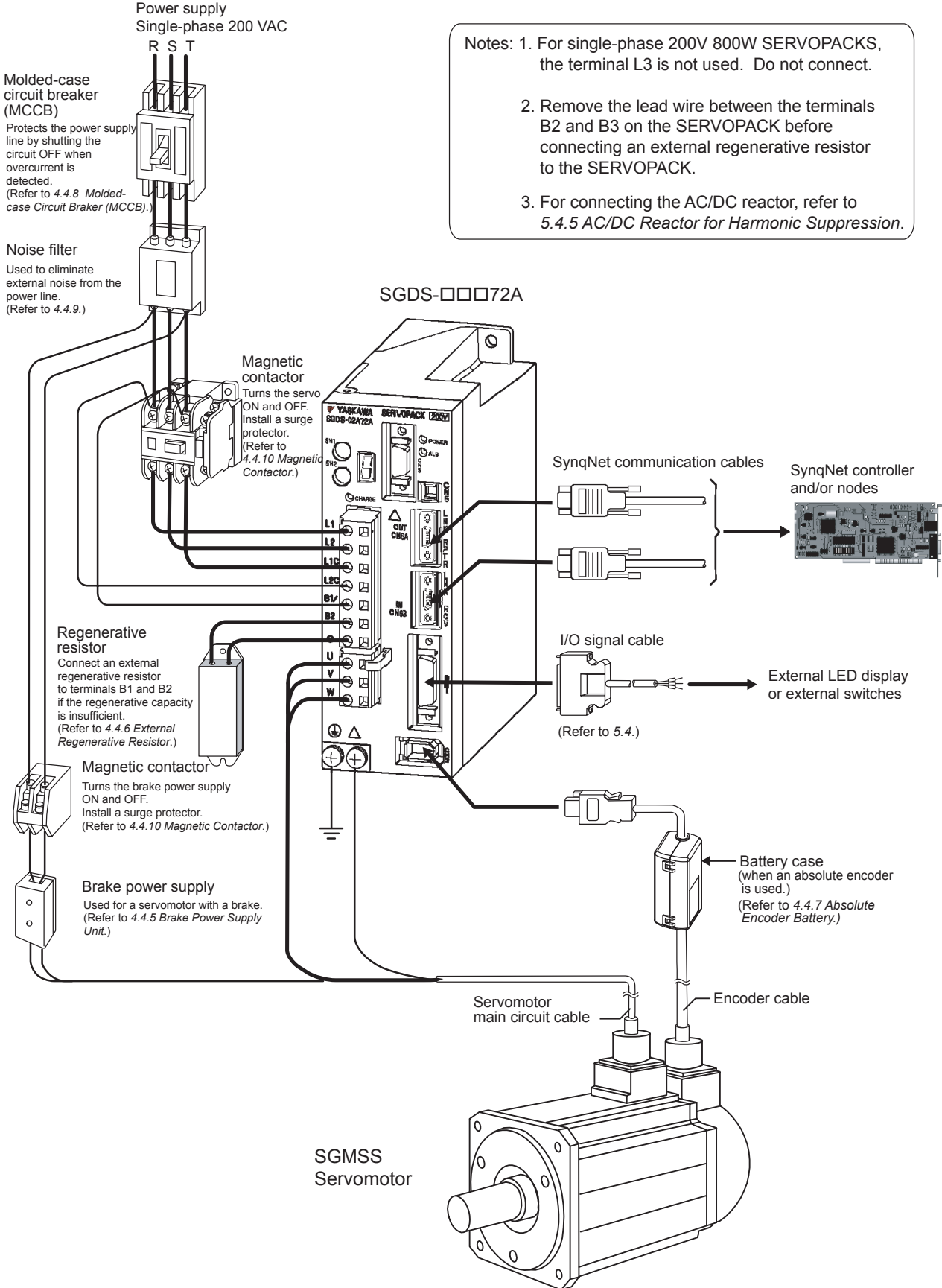

- Notes:
1. For single-phase 200V 800W SERVOPACKS, the terminal L3 is not used. Do not connect.
 2. Remove the lead wire between the terminals B2 and B3 on the SERVOPACK before connecting an external regenerative resistor to the SERVOPACK.
 3. For connecting the AC/DC reactor, refer to 5.4.5 AC/DC Reactor for Harmonic Suppression.

(4) Connecting to SGMCS Servomotor

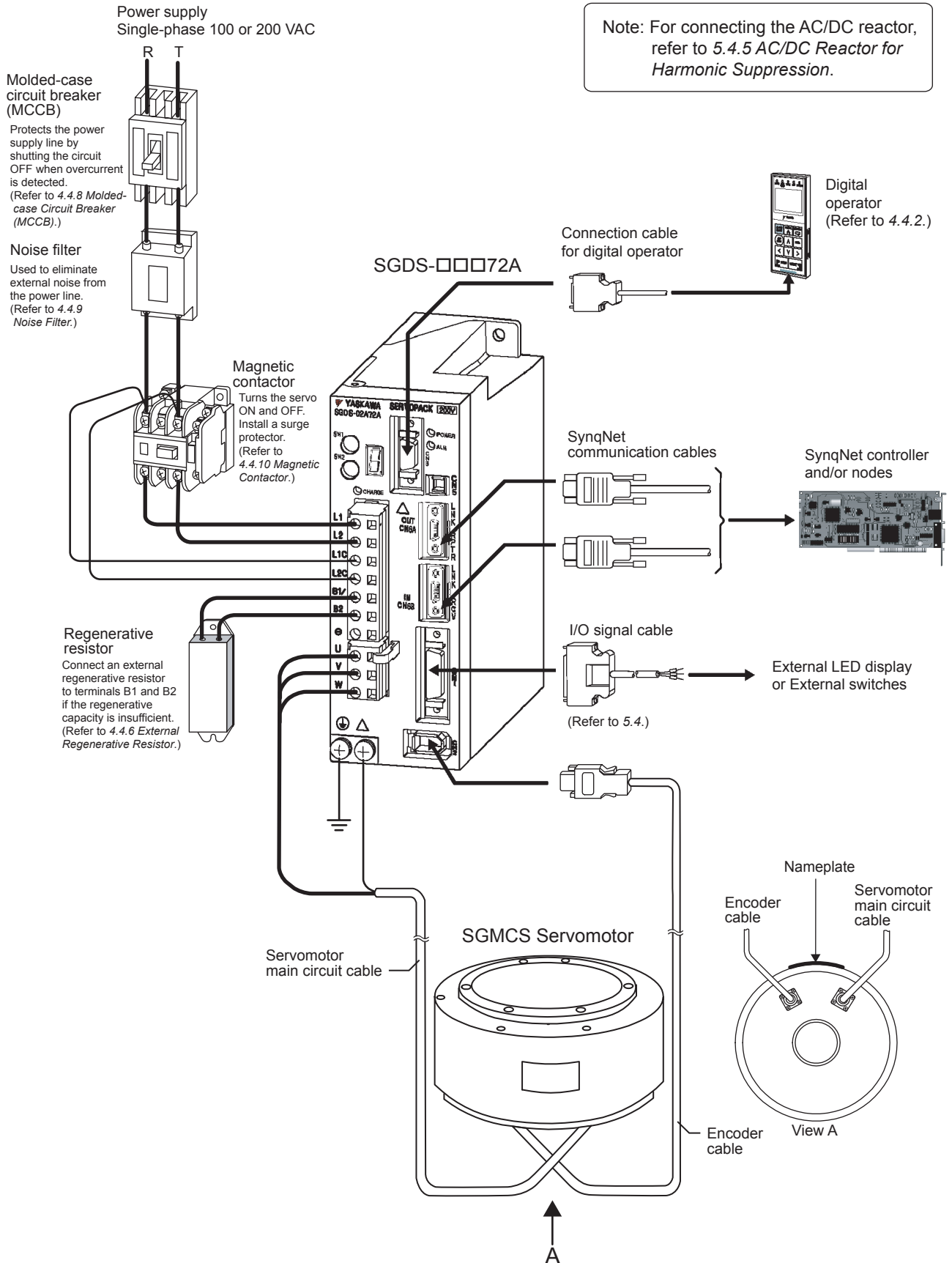

1.4 Applicable Standards

1.4.1 North American Safety Standards (UL, CSA)



Model		UL* ¹ Standards (UL File No.)	CSA* ² Standards	Certification
SERVOPACK	• SGDS	UL508C(E147823)	CSA C22.2 No.14	UL
Servomotor	• SGMAS • SGMPS • SGMSS • SGMCS	UL1004(E165827)	CSA C22.2 No.100	

* 1. Underwriters Laboratories Inc.

* 2. Canadian Standards Association.

Note: Certification is pending for the following SERVOPACKs.

- SGDS SERVOPACKs (1.5 to 3 kW)
- SGMPS-15 SERVOPACKs
- SGMSS-15 to 30 SERVOPACKs
- SGMCS-45 to 2Z SERVOPACKs

1.4.2 CE Marking



Model		Low Voltage Directive	EMC Directive		Certification
			EMI	EMS	
SERVOPACK	• SGDS	EN50178	EN55011 class A group 1	EN61000-6-2	TÜV PS*
Servomotor	• SGMAS • SGMPS • SGMSS • SGMCS	IEC60034-1 IEC60034-5 IEC60034-8 IEC60034-9			

* TÜV Product Services GmbH

Note: 1. Because SERVOPACKs and servomotors are the built-in type, reconfirmation is required after being installed in the final product.

2. Certification is pending for the following SERVOPACKs.

- SGDS SERVOPACKs (50 W to 3 kW)
- SGMPS-15 SERVOPACKs
- SGMSS-15 to 30 SERVOPACKs
- SGMCS-45 to 2Z SERVOPACKs

2.1 Servomotor Model Designations	2-2
2.1.1 Model SGMAS/SGMPS/SGMSS	2-2
2.1.2 Model SGMCS	2-4
2.2 SERVOPACK Model Designations	2-5
2.3 Σ -III Series SERVOPACKs and Applicable Servomotors	2-6
2.4 Selecting Cables	2-7
2.4.1 Cables for SGMAS and SGMPS Servomotor	2-7
2.4.2 Cables for SGMSS Servomotor	2-15
2.4.3 Cables for SGMCS Servomotor	2-20
2.5 Selecting Peripheral Devices	2-24
2.5.1 Special Options	2-24
2.5.2 Molded-case Circuit Breaker and Fuse Capacity	2-25
2.5.3 Noise Filters	2-26
2.5.4 Regenerative Resistors	2-27

2.1 Servomotor Model Designations

This section explains how to check the servomotor model and ratings. The alphanumeric codes after SGM□□ indicate the specifications.

2.1.1 Model SGMAS/SGMPS/SGMSS

(1) Without Gears

SGMAS— 01 A C A 2 1

Σ-III Series SGMAS, SGMPS and SGMSS servomotor

Rated Output (kW)			
Code	SGMAS	SGMPS	SGMSS
A5	0.05	—	—
01	0.10	0.10	—
C2	0.15	—	—
02	0.20	0.20	—
04	0.40	0.40	—
06	0.60	—	—
08	0.75	0.75	—
10	—	—	1.0
12	1.15	—	—
15	—	1.5	1.5
20	—	—	2.0
25	—	—	2.5
30	—	—	3.0

Supply Voltage

A: 200 VAC

(Servomotor is for 200 VAC also when SERVOPACK is for 100 VAC.)

Options	
Code	Specifications
1	Without options
B	With 90-VDC brake
C	With 24-VDC brake
D	With oil seal and 90-VDC brake
E	With oil seal and 24-VDC brake
S	With oil seal

Shaft End Specifications				
Code	Specifications	SGMAS	SGMPS	SGMSS
2	Straight without key	Standard	Standard	Standard
3	Taper 1/10, with key	—	—	Option
4	Straight with key	Option	Option	—
6	Straight with key and tap	Option	Option	Option
8	Straight with tap			—

Design Revision Order	
Code	Design Revision Order
A	SGMAS/SGMPS/SGMSS
E	SGMPS (IP67 specification)

Serial Encoder Specifications				
Code	Specifications	SGMAS	SGMPS	SGMSS
2	17-bit absolute	Standard	Standard	Standard
C	17-bit incremental			

Note: The number of encoder pulse is 32768 P/Rev.

(2) With Gears

SGMAS — 01 A C A H 1 2 B

Σ-III Series SGMAS, SGMP5 and SGMSS servomotor

Rated Output (kW)			
Code	SGMAS	SGMP5	SGMSS
A5	0.05	—	—
01	0.10	0.10	—
C2	0.15	—	—
02	0.20	0.20	—
04	0.40	0.40	—
06	0.60	—	—
08	0.75	0.75	—
10	—	—	1.0
12	1.15	—	—
15	—	1.5	1.5
20	—	—	2.0
25	—	—	2.5
30	—	—	3.0

Supply Voltage
 A: 200 VAC
 (Servomotor is for 200 VAC also when SERVOPACK is for 100 VAC.)

Serial Encoder Specifications				
Code	Specifications	SGMAS	SGMP5	SGMSS
2	17-bit absolute	Standard	Standard	Standard
C	17-bit incremental			

Note: The number of encoder pulses is 32768 P/Rev.

Design Revision Order	
Code	Design Revision Order
A	SGMAS/SGMP5/SGMSS
E	SGMP5 (IP67 specification)

Note: SGMP5 servomotors conform to IP67, but the gears do not.

Options	
1	Without brake
B	With 90-VDC brake
C	With 24-VDC brake

Shaft End Specifications				
Code	Specifications	SGMAS	SGMP5	SGMSS
0	Flange type (no shaft)	H	H	—
2	Straight without key	H, J	H, J	—
4	Straight with key	—	—	L
6	Straight with key and tap	H, J	H, J	—
8	Straight with tap	H	H	—

Gear Ratio				
Code	Gear Ratio	SGMAS	SGMP5	SGMSS
B	1/11	H (-01A to -12A) J (only -12A)	H (-01A to -15A) J (only -15A)	—
C	1/21	H, J	H, J	—
1	1/5	H, J	H, J	L
2	1/9	H (only -A5A)	—	L
3	3/31	J (-A5A to -08A)	J (-01A to -08A)	—
5	1/20	—	—	L
7	1/29	—	—	L
	1/33	H, J	H, J	—
8	1/45	—	—	L

Gear Type	
Code	Specifications
H	HDS planetary low-backlash gear (SGMAS/SGMP5)
J	Standard backlash gear (SGMAS/SGMP5)
L	Low-backlash gear (SGMSS)

2.1.2 Model SGMCS

SGMCS—02 B 3 B 1 1

Σ-III Series SGMCS servomotor

Rated Torque (N·m)		Motor Outer Diameter (mm)					
Code	Specifications	B (φ135)	C (φ175)	D (φ230)	E (φ290)	M (φ280)	N (φ360)
02	2.0	○					
04	4.0		○				
05	5.0	○					
07	7.0	○					
08	8.0			○			
10	10.0		○				
14	14.0		○				
16	16.0				○		
17	17.0			○			
25	25.0			○			
35	35.0				○		
45	45.0					○	
80	80.0					○	○
1A	110.0					○	
1E	150.0						○
2Z	200.0						○

Brake Specifications	
Code	Specifications
1	Without brake

Flange Specifications	
Code	Specifications
1	C face

Design Revision Order	
Code	Specifications
A	45 to 200 N·m
B	2 to 35 N·m

Serial Encoder Specifications		
Code	Specifications	Remarks
3	20-bit absolute (without multiturn data)	Standard
D	20-bit incremental	Option



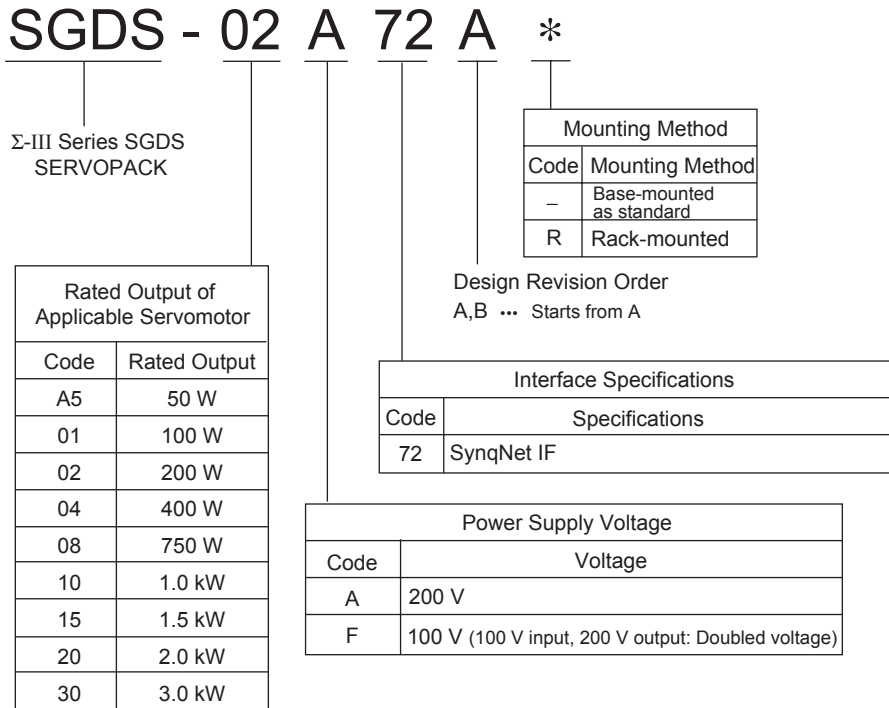

2.2 SERVOPACK Model Designations

Select the SERVOPACK according to the applied servomotor.



2.3 Σ-III Series SERVOPACKs and Applicable Servomotors

Table 2.1 SERVOPACKs and Applicable Servomotors

Σ-III Series SGM□IS servomotor		Σ-III Series SGDS SERVOPACK		
		Single-phase 100 VAC	Single-phase 200 VAC	Three-phase 200 VAC
SGMAS (Super High Power Capacity)  3000min ⁻¹ 8 models	A5A (50 W)	A5F	A5A	–
	01A (100 W)	01F	01A	–
	C2A (150 W)	02F	02A	–
	02A (200 W)	02F	02A	–
	04A (400 W)	04F	04A	–
	06A (600 W)	–	08A	–
	08A (750 W)	–	08A	–
	12A (1.15 kW)	–	–	15A
SGMPS (Flat Type)  3000min ⁻¹ 5 models	01A (100 W)	01F	01A	–
	02A (200 W)	02F	02A	–
	04A (400 W)	04F	04A	–
	08A (750 W)	–	08A	–
	15A (1.5 kW)	–	–	15A
SGMSS (Super High Power Capacity)  3000min ⁻¹ 5 model	10A (1.0 kW)	–	–	10A
	15A (1.5 kW)	–	–	15A
	20A (2.0 kW)	–	–	20A
	25A (2.5 kW)	–	–	30A
	30A (3.0 kW)	–	–	30A
SGMCS (Direct Drive)  200min ⁻¹ 9 models 150min ⁻¹ 8 models	02B (42 W)	02F	02A	–
	05B (105 W)	02F	02A	–
	07B (147 W)	02F	02A	–
	04C (84 W)	04F	04A	–
	08D	04F	04A	–
	10C (209 W)	04F	04A	–
	14C (293 W)	04F	04A	–
	08C (168 W)	04F	04A	–
	17D (356 W)	04F	04A	–
	25D (393 W)*	04F	04A	–
	16E (335 W)	–	08A	–
	35E (550 W)*	–	08A	–
	45M	–	–	10A
	80M	–	–	15A
	1AM	–	–	20A
	80N	–	–	15A
	1EN	–	–	30A
2ZN	–	–	30A	

* The rated speed of servomotor model SGMCS-25D and SGMCS-35E is 150 min⁻¹.

Note: Models with gears are available (excluding SGMCS).

2.4 Selecting Cables

2.4.1 Cables for SGMAS and SGMP5 Servomotor

- Cable Connection for Standard Wiring Distance

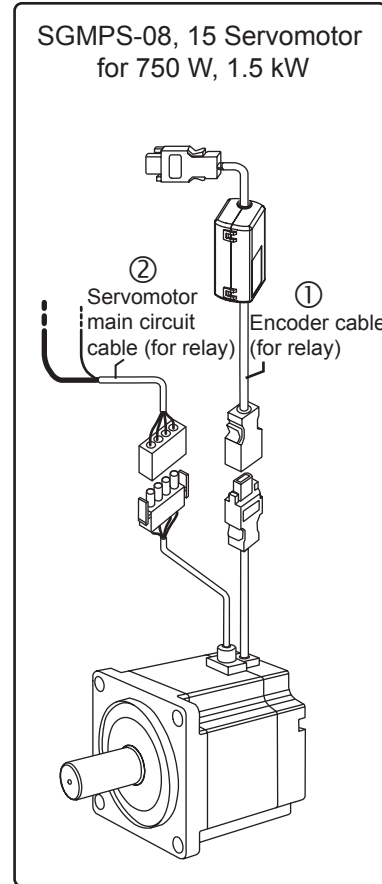
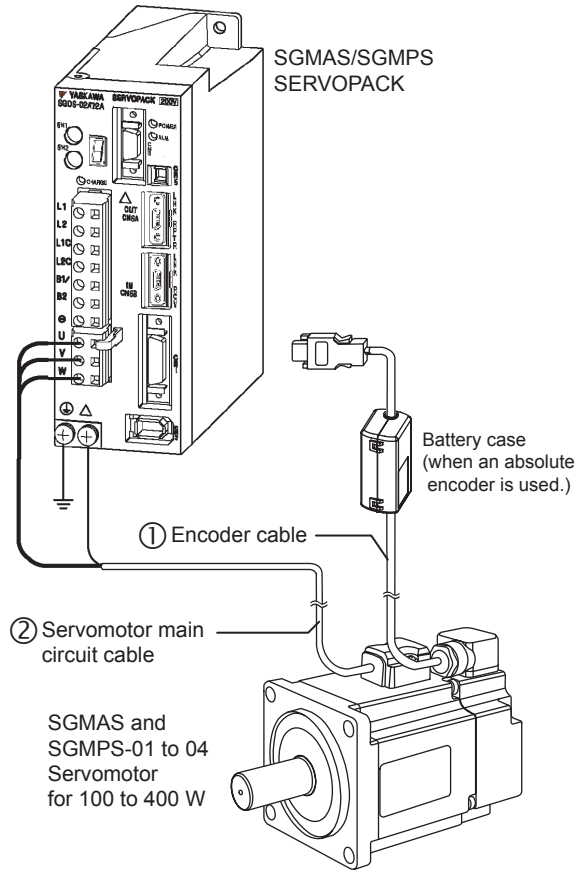



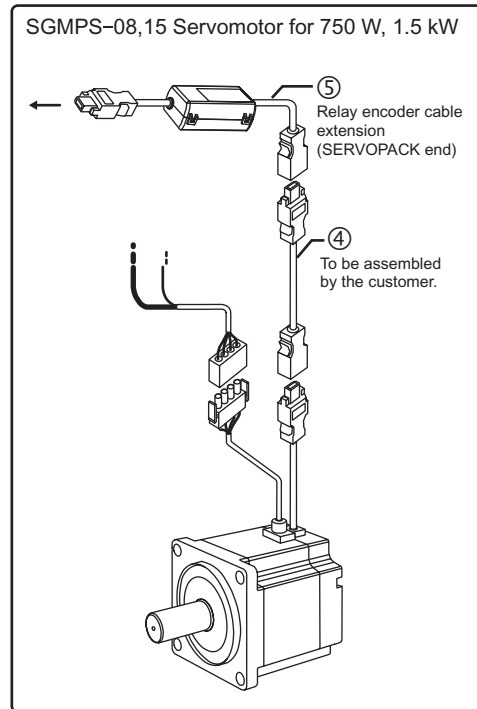
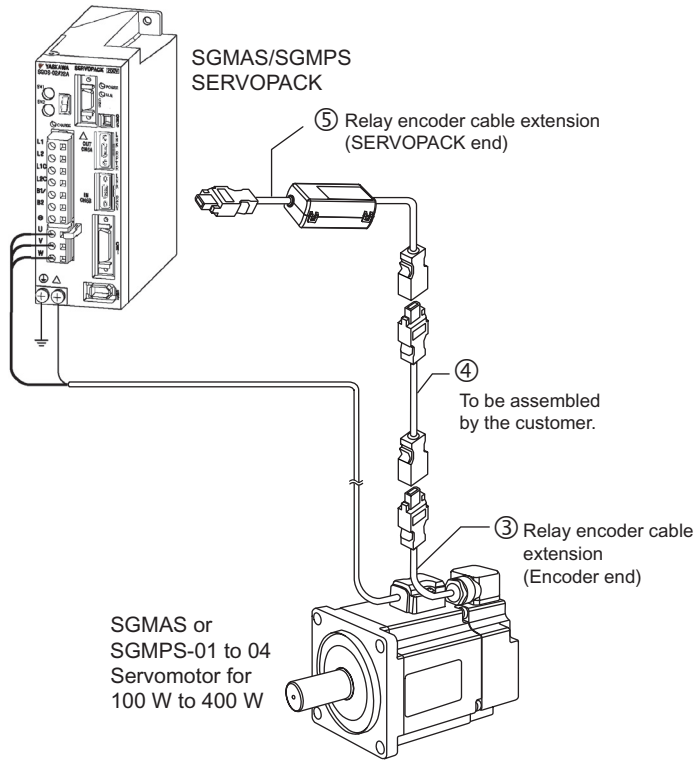

2

2.4.1 Cables for SGMAS and SGMP5 Servomotor

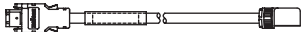
- Encoder Cable Extension from 20 m (65.5 ft) up to 50 m (164 ft)

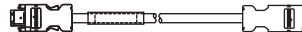





Name	Servomotor Model	Length	Type		Specifications		
			Standard Type	Flexible Type *			
① CN2 Encoder cable	Cable with connectors at both ends (For incremental encoder)	SGMAS for 50 to 1.15 kW,	3 m (9.84 ft)	JZSP-CSP01-03	JZSP-CSP21-03	SERVOPACK end Encoder end 	
			5 m (16.4 ft)	JZSP-CSP01-05	JZSP-CSP21-05		
			10 m (32.8 ft)	JZSP-CSP01-10	JZSP-CSP21-10		
			15 m (49.2 ft)	JZSP-CSP01-15	JZSP-CSP21-15		
			20 m (65.5 ft)	JZSP-CSP01-20	JZSP-CSP21-20		
	Cable with connectors at both ends (For absolute encoder: with battery case)	SGMPS for 100 to 400 W	3 m (9.84 ft)	JZSP-CSP05-03	JZSP-CSP25-03	SERVOPACK end Encoder end 	
			5 m (16.4 ft)	JZSP-CSP05-05	JZSP-CSP25-05		
			10 m (32.8 ft)	JZSP-CSP05-10	JZSP-CSP25-10		
			15 m (49.2 ft)	JZSP-CSP05-15	JZSP-CSP25-15		
			20 m (65.5 ft)	JZSP-CSP05-20	JZSP-CSP25-20		
	Cable with connectors at both ends (For incremental encoder)	SGMPS for 750 W, 1.5 kW	3 m (9.84 ft)	JZSP-CMP00-03	JZSP-CMP10-03	SERVOPACK end Encoder end 	
			5 m (16.4 ft)	JZSP-CMP00-05	JZSP-CMP10-05		
			10 m (32.8 ft)	JZSP-CMP00-10	JZSP-CMP10-10		
			15 m (49.2 ft)	JZSP-CMP00-15	JZSP-CMP10-15		
			20 m (65.5 ft)	JZSP-CMP00-20	JZSP-CMP10-20		
		Cable with connectors at both ends (For absolute encoder: with battery case)	SGMPS for 750 W, 1.5 kW	3 m (9.84 ft)	JZSP-CSP19-03	JZSP-CSP29-03	SERVOPACK end Encoder end 
				5 m (16.4 ft)	JZSP-CSP19-05	JZSP-CSP29-05	
				10 m (32.8 ft)	JZSP-CSP19-10	JZSP-CSP29-10	
				15 m (49.2 ft)	JZSP-CSP19-15	JZSP-CSP29-15	
				20 m (65.5 ft)	JZSP-CSP19-20	JZSP-CSP29-20	

* Use flexible cables for movable sections such as robot arms. Refer to 5.6 Flexible Cables.

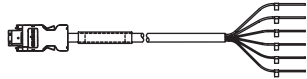
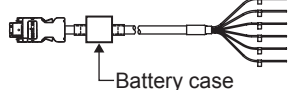
Note: When the battery of the host controller is used for the absolute encoder, no battery case is required.
In this case, use a cable for the incremental encoder.

(cont'd)

	Name	Servomotor Model	Length	Type		Specifications
				Standard Type	Flexible Type *	
① CN2 Encoder cable (Cont.)	Cable with loose wire at encoder end (For incremental encoder)	SGMAS 50 to 1.15 kW, SGMP5 100 to 1.5 kW	3 m (9.84 ft)	JZSP-CMP03-03	JZSP-CMP13-03	
			5 m (16.4 ft)	JZSP-CMP03-05	JZSP-CMP13-05	
			10 m (32.8 ft)	JZSP-CMP03-10	JZSP-CMP13-10	
			15 m (49.2 ft)	JZSP-CMP03-15	JZSP-CMP13-15	
			20 m (65.5 ft)	JZSP-CMP03-20	JZSP-CMP13-20	
	Cable with loose wire at encoder end (For absolute encoder: with battery case)	SGMAS 50 to 1.15 kW, SGMP5 100 to 1.5 kW	3 m (9.84 ft)	JZSP-CSP04-03	JZSP-CSP24-03	
			5 m (16.4 ft)	JZSP-CSP04-05	JZSP-CSP24-05	
			10 m (32.8 ft)	JZSP-CSP04-10	JZSP-CSP24-10	
			15 m (49.2 ft)	JZSP-CSP04-15	JZSP-CSP24-15	
			20 m (65.5 ft)	JZSP-CSP04-20	JZSP-CSP24-20	
	SERVOPACK end connector kit	SGMAS SGMP5		JZSP-CMP9-1		Soldered 
	Encoder end connector kit	SGMAS 50 to 1.15 kW, SGMP5 100 to 400 W		JZSP-CSP9-2		Caulking (Exclusive tool is required.) 
		SGMP5 750 W, 1.5 kW		JZSP-CMP9-2		Soldered 
	Cables		5 m (16.4 ft)	JZSP-CMP09-05	JZSP-CSP39-05	20 m(65.5 ft) max. 
			10 m (32.8 ft)	JZSP-CMP09-10	JZSP-CSP39-10	
			15 m (49.2 ft)	JZSP-CMP09-15	JZSP-CSP39-15	
			20 m (65.5 ft)	JZSP-CMP09-20	JZSP-CSP39-20	

* Use flexible cables for movable sections such as robot arms. Refer to 5.6 Flexible Cables.

Note: When the battery of the host controller is used for the absolute encoder, no battery case is required.

In this case, use a cable for the incremental encoder.

(cont'd)

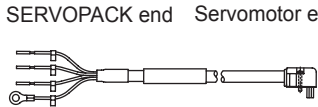
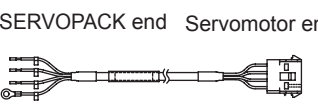
Name	Servomotor Model	Length	Type		Specifications		
			Standard Type	Flexible Type *			
② CN3 Servo- motor Main Circuit Cables	Without brakes	SGMAS 50 to 150 W, SGMPS 100 W	3 m (9.84 ft)	JZSP-CSM01-03	JZSP-CSM21-03		
			5 m (16.4 ft)	JZSP-CSM01-05	JZSP-CSM21-05		
			10 m (32.8 ft)	JZSP-CSM01-10	JZSP-CSM21-10		
			15 m (49.2 ft)	JZSP-CSM01-15	JZSP-CSM21-15		
			20 m (65.5 ft)	JZSP-CSM01-20	JZSP-CSM21-20		
		SGMAS 200 to 600 W, SGMPS 200 to 400 W	3 m (9.84 ft)	JZSP-CSM02-03	JZSP-CSM22-03		
			5 m (16.4 ft)	JZSP-CSM02-05	JZSP-CSM22-05		
			10 m (32.8 ft)	JZSP-CSM02-10	JZSP-CSM22-10		
			15 m (49.2 ft)	JZSP-CSM02-15	JZSP-CSM22-15		
			20 m (65.5 ft)	JZSP-CSM02-20	JZSP-CSM22-20		
		SGMAS 750 W, 1.15 kW	3 m (9.84 ft)	JZSP-CSM03-03	JZSP-CSM23-03		
			5 m (16.4 ft)	JZSP-CSM03-05	JZSP-CSM23-05		
			10 m (32.8 ft)	JZSP-CSM03-10	JZSP-CSM23-10		
			15 m (49.2 ft)	JZSP-CSM03-15	JZSP-CSM23-15		
			20 m (65.5 ft)	JZSP-CSM03-20	JZSP-CSM23-20		
		SGMPS 750 W	3 m (9.84 ft)	JZSP-CMM00-03	JZSP-CMM01-03		
			5 m (16.4 ft)	JZSP-CMM00-05	JZSP-CMM01-05		
			10 m (32.8 ft)	JZSP-CMM00-10	JZSP-CMM01-10		
			15 m (49.2 ft)	JZSP-CMM00-15	JZSP-CMM01-15		
			20 m (65.5 ft)	JZSP-CMM00-20	JZSP-CMM01-20		



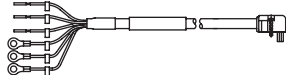

* Use flexible cables for movable sections such as robot arms. Refer to 5.6 Flexible Cables.

(cont'd)

Name	Servomotor Model	Length	Type		Specifications	
			Standard Type	Flexible Type *		
② CN3 Servomotor Main Circuit Cables (Cont.)	Without brakes (Cont.)	SGMPS 1.5 kW	3 m (9.84 ft)	JZSP-CMM20-03	—	SERVOPACK end Servomotor end 
			5 m (16.4 ft)	JZSP-CMM20-05	—	
			10 m (32.8 ft)	JZSP-CMM20-10	—	
			15 m (49.2 ft)	JZSP-CMM20-15	—	
			20 m (65.5 ft)	JZSP-CMM20-20	—	
	With brakes	SGMAS 50 to 150 W, SGMPS 100 W	3 m (9.84 ft)	JZSP-CSM11-03	JZSP-CSM31-03	SERVOPACK end Servomotor end 
			5 m (16.4 ft)	JZSP-CSM11-05	JZSP-CSM31-05	
			10 m (32.8 ft)	JZSP-CSM11-10	JZSP-CSM31-10	
			15 m (49.2 ft)	JZSP-CSM11-15	JZSP-CSM31-15	
			20 m (65.5 ft)	JZSP-CSM11-20	JZSP-CSM31-20	
		SGMAS 200 to 600 W, SGMPS 200 to 400 W	3 m (9.84 ft)	JZSP-CSM12-03	JZSP-CSM32-03	
			5 m (16.4 ft)	JZSP-CSM12-05	JZSP-CSM32-05	
			10 m (32.8 ft)	JZSP-CSM12-10	JZSP-CSM32-10	
			15 m (49.2 ft)	JZSP-CSM12-15	JZSP-CSM32-15	
			20 m (65.5 ft)	JZSP-CSM12-20	JZSP-CSM32-20	
		SGMAS 750 W, 1.15 kW	3 m (9.84 ft)	JZSP-CSM13-03	JZSP-CSM33-03	
			5 m (16.4 ft)	JZSP-CSM13-05	JZSP-CSM33-05	
			10 m (32.8 ft)	JZSP-CSM13-10	JZSP-CSM33-10	
			15 m (49.2 ft)	JZSP-CSM13-15	JZSP-CSM33-15	
			20 m (65.5 ft)	JZSP-CSM13-20	JZSP-CSM33-20	

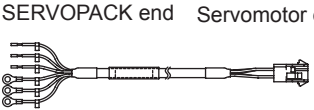

* Use flexible cables for movable sections such as robot arms. Refer to 5.6 Flexible Cables.

(cont'd)

Name		Servomotor Model	Length	Type		Specifications
				Standard Type	Flexible Type *	
② CN3 Servo- motor Main Cir- cuit Cables (Cont.)	With brakes (Cont.)	SGMPS 750 W	3 m (9.84 ft)	JZSP-CMM10-03	JZSP-CMM11-03	
			5 m (16.4 ft)	JZSP-CMM10-05	JZSP-CMM11-05	
			10 m (32.8 ft)	JZSP-CMM10-10	JZSP-CMM11-10	
			15 m (49.2 ft)	JZSP-CMM10-15	JZSP-CMM11-15	
			20 m (65.5 ft)	JZSP-CMM10-20	JZSP-CMM11-20	
		SGMPS 1.5 kW	3 m (9.84 ft)	JZSP-CMM30-03	—	
			5 m (16.4 ft)	JZSP-CMM30-05	—	
			10 m (32.8 ft)	JZSP-CMM30-10	—	
			15 m (49.2 ft)	JZSP-CMM30-15	—	
			20 m (65.5 ft)	JZSP-CMM30-20	—	
Servomotor end connector kit	SGMAS 50 to 150 W	JZSP-CSM9-1		Caulking (Exclusive tool is required.) 		
	SGMPS 100 W					
	SGMAS 200 to 600 W,	JZSP-CSM9-2				
	SGMPS 200 to 400 W					
	SGMAS 750 W, 1.15 kW	JZSP-CSM9-3	JZSP-CSM9-4	Caulking 		
	SGMPS 750 W (Without brakes)	JZSP-CMM9-1				
	SGMPS 1.5 kW (Without brakes)	JZSP-CMM9-3		Caulking 		
	SGMPS 750 W (With brakes)	JZSP-CMM9-2	JZSP-CSM9-5			
SGMPS 1.5 kW (With brakes)	JZSP-CMM9-4	—				

* Use flexible cables for movable sections such as robot arms. Refer to 5.6 Flexible Cables.

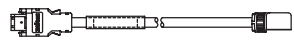
(cont'd)

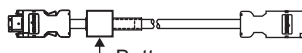
Name	Servomotor Model	Length	Type		Specifications			
			Standard Type	Flexible Type *				
② CN3 Servomotor Main Circuit Cables (Cont.)	Cables	SGMAS 50 to 600 W	5 m (16.4 ft)	JZSP-CSM90-05	JZSP-CSM80-05	20 m (65.6 ft) max. 		
			10 m (32.8 ft)	JZSP-CSM90-10	JZSP-CSM80-10			
		SGMPS 100 to 400 W	15 m (49.2 ft)	JZSP-CSM90-15	JZSP-CSM80-15			
			20 m (65.5 ft)	JZSP-CSM90-20	JZSP-CSM80-20			
		SGMAS 750 W, 1.15 kW	5 m (16.4 ft)	JZSP-CSM91-05	JZSP-CSM81-05			
			10 m (32.8 ft)	JZSP-CSM91-10	JZSP-CSM81-10			
			15 m (49.2 ft)	JZSP-CSM91-15	JZSP-CSM81-15			
			20 m (65.5 ft)	JZSP-CSM91-20	JZSP-CSM81-20			
		③ Relay Encoder Cables	Encoder end (Same for incremental and absolute encoders)	SGMAS 50 W to 1.15 kW	0.3 m (0.984 ft)		JZSP-CSP11	SERVOPACK end Encoder end 
				SGMPS 100 W to 400 W				
④ Wires and Connectors for Relay Encoder Cable Extensions	Wires and connectors for relay encoder cable extensions are available for assembly by the customer.	30 m (98.425 ft)	JZSP-CMP19-30	50m (164.042 ft) max. 				
		40 m (131.234 ft)	JZSP-CMP19-40					
		50 m (164.042 ft)	JZSP-CMP19-50					
⑤ Relay Encoder Cables	SERVOPACK end (For absolute encoders, with a battery case)	SGMAS 50 W to 1.15kW	0.3 m (0.984 ft)	JZSP-CSP12*2	SERVOPACK end Encoder end  Battery case (Battery attached)			
		SGMPS 100 W to 1.5 kW						

* 1. Use flexible cables for movable sections such as robot arms. For the precautions on handling flexible cables, refer to 5.6 Flexible Cables.

* 2. Not required when using an incremental encoder or using an absolute encoder with a battery connected to the host controller.

2.4.2 Cables for SGMSS Servomotor



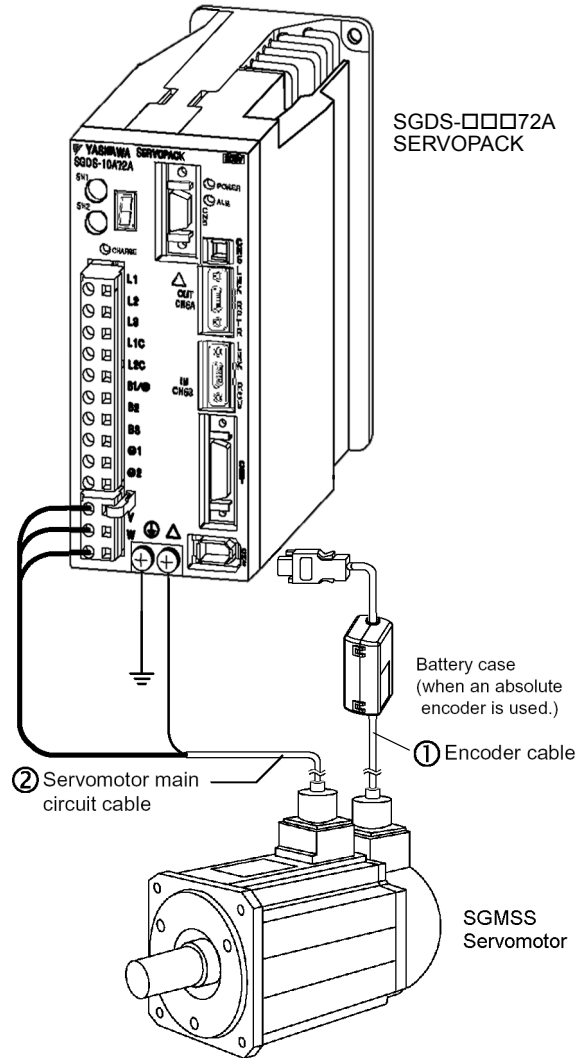



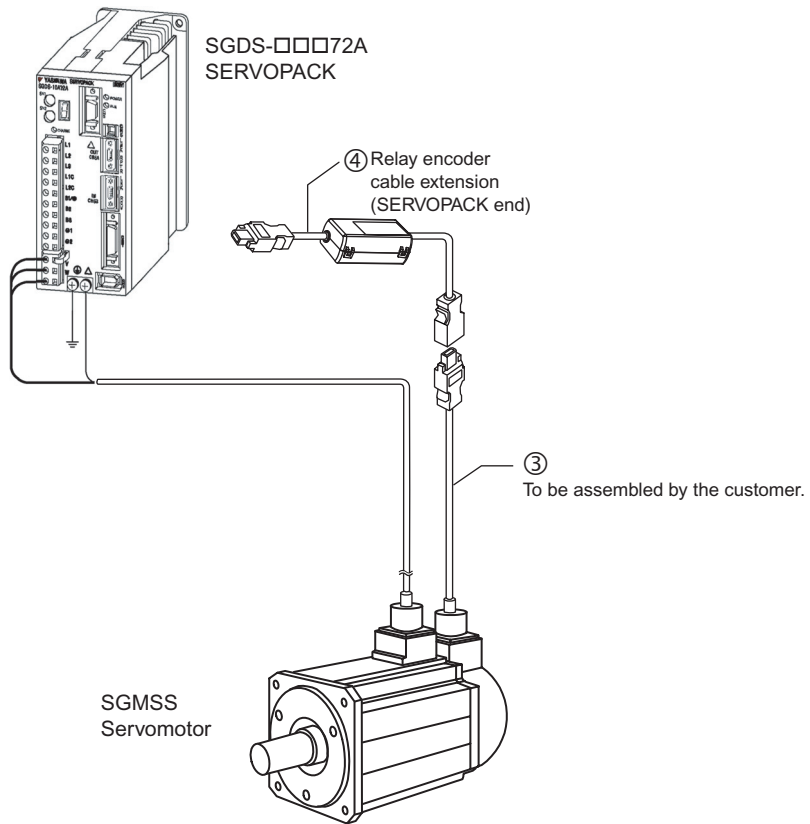

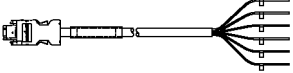
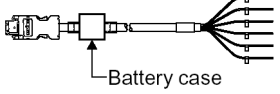
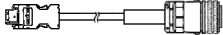
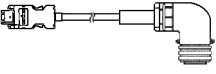
- Cable Connection for Standard Wiring Distance

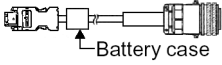
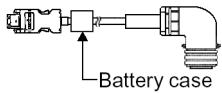

- Encoder Cable Extension from 20 m (65.5 ft) up to 50 m (164 ft)



Name		Length	Type		Specification	
			Standard Type	Flexible Type		
① CN2 Encoder Cable	Cable with loose wire at encoder end (For incremental encoder)	3 m (9.84 ft)	JZSP-CMP03-03	JZSP-CMP13-03	SERVOPACK end Encoder end 	
		5 m (16.4 ft)	JZSP-CMP03-05	JZSP-CMP13-05		
		10 m (32.8 ft)	JZSP-CMP03-10	JZSP-CMP13-10		
		15 m (49.2 ft)	JZSP-CMP03-15	JZSP-CMP13-15		
		20 m (65.5 ft)	JZSP-CMP03-20	JZSP-CMP13-20		
	Cable with loose wire at encoder end (For absolute encoder: with battery case)	3 m (9.84 ft)	JZSP-CSP04-03	JZSP-CSP24-03	SERVOPACK end Encoder end 	
		5 m (16.4 ft)	JZSP-CSP04-05	JZSP-CSP24-05		
		10 m (32.8 ft)	JZSP-CSP04-10	JZSP-CSP24-10		
		15 m (49.2 ft)	JZSP-CSP04-15	JZSP-CSP24-15		
		20 m (65.5 ft)	JZSP-CSP04-20	JZSP-CSP24-20		
	Cable with connectors at both ends (For incremental encoder)	With a straight plug	3 m (9.84 ft)	JZSP-CMP01-03	JZSP-CMP11-03	SERVOPACK end Encoder end 
			5 m (16.4 ft)	JZSP-CMP01-05	JZSP-CMP11-05	
			10 m (32.8 ft)	JZSP-CMP01-10	JZSP-CMP11-10	
			15 m (49.2 ft)	JZSP-CMP01-15	JZSP-CMP11-15	
			20 m (65.5 ft)	JZSP-CMP01-20	JZSP-CMP11-20	
		With a L-shaped plug	3 m (9.84 ft)	JZSP-CMP02-03	JZSP-CMP12-03	SERVOPACK end Encoder end 
			5 m (16.4 ft)	JZSP-CMP02-05	JZSP-CMP12-05	
			10 m (32.8 ft)	JZSP-CMP02-10	JZSP-CMP12-10	
			15 m (49.2 ft)	JZSP-CMP02-15	JZSP-CMP12-15	
			20 m (65.5 ft)	JZSP-CMP02-20	JZSP-CMP12-20	

Name		Length	Type		Specification	
			Standard Type	Flexible Type		
① CN2 Encoder Cable (cont.)	Cable with connectors at both ends (For absolute encoder: with battery case)	3 m (9.84 ft)	JZSP-CSP06-03	JZSP-CSP26-03	With a straight plug SERVOPACK end Encoder end 	
		5 m (16.4 ft)	JZSP-CSP06-05	JZSP-CSP26-05		
		10 m (32.8 ft)	JZSP-CSP06-10	JZSP-CSP26-10		
		15 m (49.2 ft)	JZSP-CSP06-15	JZSP-CSP26-15		
		20 m (65.5 ft)	JZSP-CSP06-20	JZSP-CSP26-20		
		3 m (9.84 ft)	JZSP-CSP07-03	JZSP-CSP27-03		With a L-shaped plug SERVOPACK end Encoder end 
		5 m (16.4 ft)	JZSP-CSP07-05	JZSP-CSP27-05		
		10 m (32.8 ft)	JZSP-CSP07-10	JZSP-CSP27-10		
		15 m (49.2 ft)	JZSP-CSP07-15	JZSP-CSP27-15		
		20 m (65.5 ft)	JZSP-CSP07-20	JZSP-CSP27-20		
	SERVOPACK end connector kit	JZSP-CMP9-1	Soldered			
	For standard environment Encoder end connector	MS3106B20-29S*		Straight plug		
		MS3108B20-29S*		L-shaped plug		
		MS3057-12A		Cable clamp		
	For IP67 specification Encoder end connector	JA06A-20-29S-J1-EB*		Straight plug		
JA08A-20-29S-J1-EB*		L-shaped plug				
JL04-2022CKE (09)* Cable diameter: φ 6.5 to φ 9.5 mm		Cable clamp				
JL04-2022CKE (12)* Cable diameter: φ 9.5 to φ 13 mm						
JL04-2022CKE (14)* Cable diameter: φ 12.9 to φ 15.9 mm						

* Contact Japan Aviation Electronics Industry, Ltd.

Name		Length	Type		Specification
			Standard Type	Flexible Type	
① CN2 Encoder Cable (cont.)	Cable	5 m (16.4 ft)	JZSP-CMP09-05		20 m (65.5 ft) max. 
		10 m (32.8 ft)	JZSP-CMP09-10		
		15 m (49.2 ft)	JZSP-CMP09-15		
		20 m (65.5 ft)	JZSP-CMP09-20		
② Servomotor Main Circuit Ca- ble Connectors	Cables and connectors			Cables with connectors are not available. Refer to <i>5 Wiring</i> .	



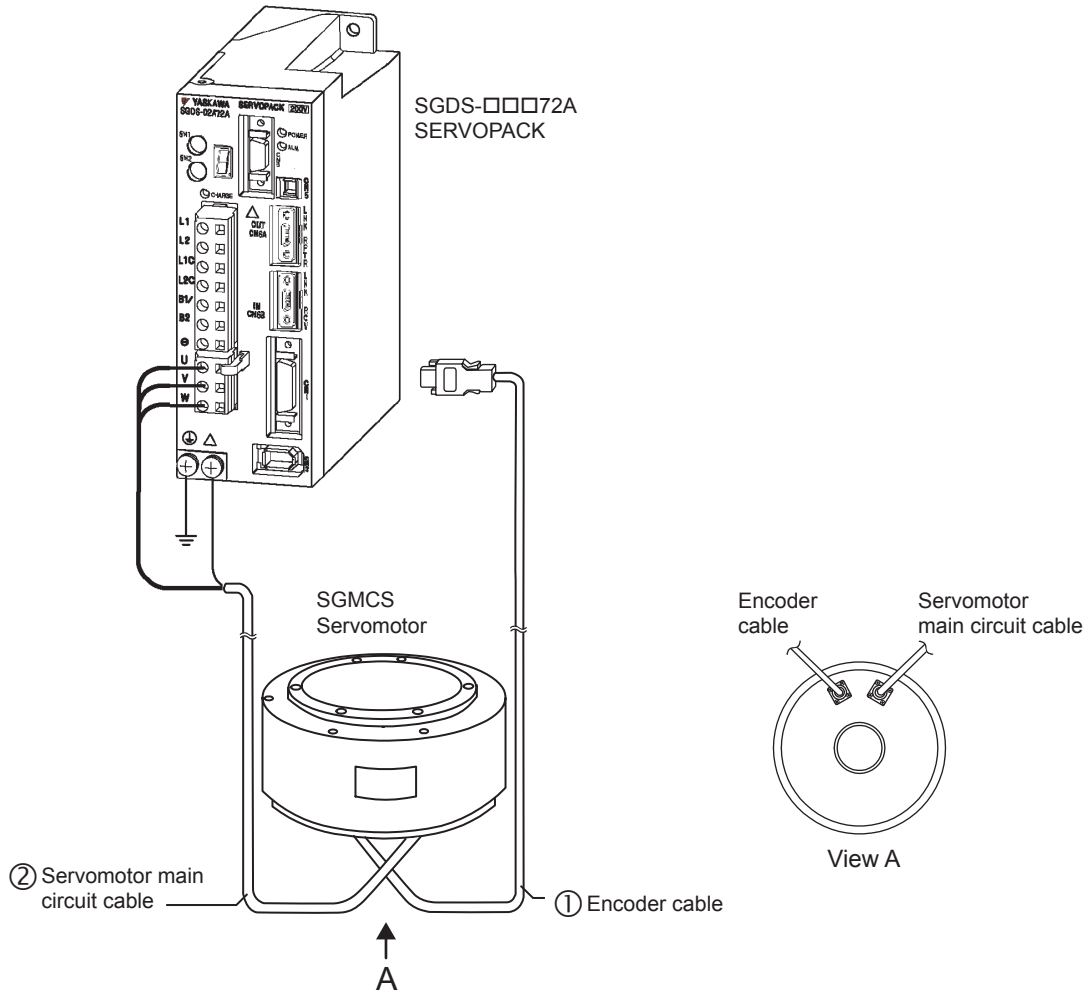

2.4.3 Cables for SGMCS Servomotor

- Cable Connection for Standard Wiring Distance

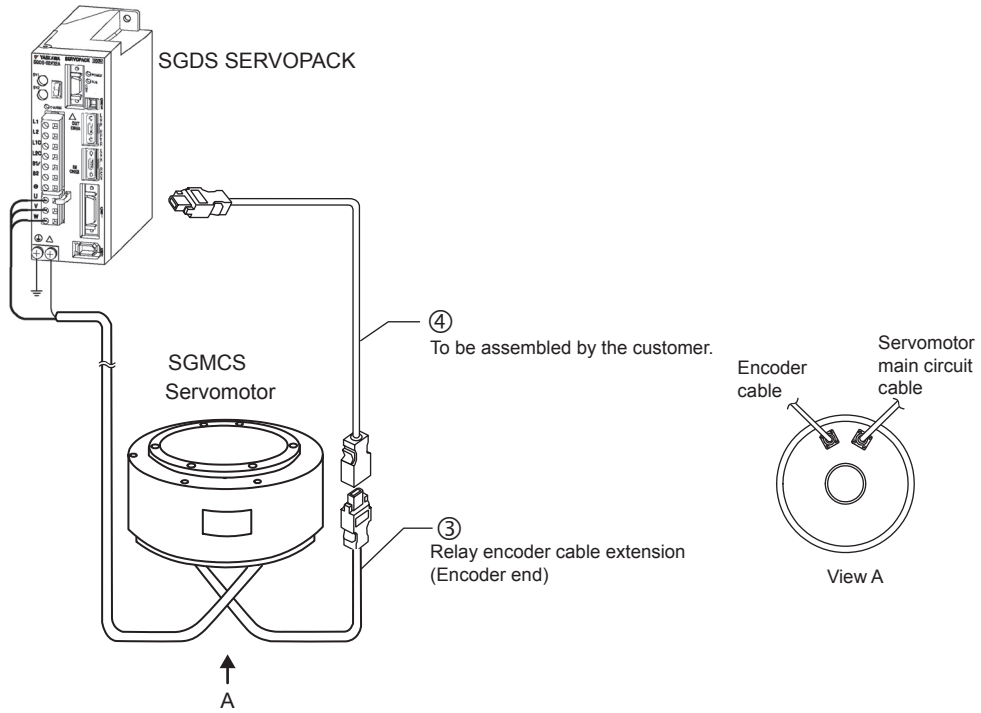

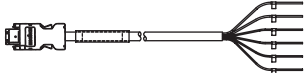
- Encoder Cable Extension from 20m (65.5 ft) up to 50m (164 ft)







Name		Length	Type		Specifications
			Standard Type	Flexible Type *1	
① CN2 Encoder Cables	Cable with connectors at both ends (For incremental and absolute encoder)	3 m (9.84 ft)	JZSP-CMP60-03	JZSP-CSP60-03	SERVOPACK end Encoder end 
		5 m (16.4 ft)	JZSP-CMP60-05	JZSP-CSP60-05	
		10 m (32.8 ft)	JZSP-CMP60-10	JZSP-CSP60-10	
		15 m (49.2 ft)	JZSP-CMP60-15	JZSP-CSP60-15	
		20 m (65.5 ft)	JZSP-CMP60-20	JZSP-CSP60-20	
	Cable with loose wires at encoder end (For incremental and absolute encoder)	3 m (9.84 ft)	JZSP-CMP03-03	JZSP-CMP13-03	SERVOPACK end Encoder end 
		5 m (16.4 ft)	JZSP-CMP03-05	JZSP-CMP13-05	
		10 m (32.8 ft)	JZSP-CMP03-10	JZSP-CMP13-10	
		15 m (49.2 ft)	JZSP-CMP03-15	JZSP-CMP13-15	
		20 m (65.5 ft)	JZSP-CMP03-20	JZSP-CMP13-20	
	SERVOPACK end connector kit		JZSP-CMP9-1		Soldered 
	Connectors at encoder end (Straight plug)		JN1DS10SL1*2		Caulking (Exclusive tool is required.) 
	Connectors at encoder end (Socket contact)		JN1-22-22S-PKG100*2		
	Cables	5 m (16.4 ft)	JZSP-CMP09-05	JZSP-CSP39-05	20 m (65.6 ft) max. 
		10 m (32.8 ft)	JZSP-CMP09-10	JZSP-CSP39-10	
		15 m (49.2 ft)	JZSP-CMP09-15	JZSP-CSP39-15	
		20 m (65.5 ft)	JZSP-CMP09-20	JZSP-CSP39-20	

* 1. Use flexible cables for movable sections such as robot arms. Refer to 5.6 *Flexible Cables*.

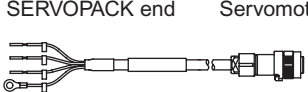
* 2. Contact Japan Aviation Electronics Industry, Ltd.

(cont'd)

Name			Length	Type		Specifications
				Standard Type	Flexible Type *1	
② Servomotor Main Circuit Cable Connectors	Without brakes (For small- capacity series)	SGMCS- □□B,C,D,E	3 m (9.84 ft)	JZSP-CMM60-03	JZSP-CSM60-03	
			5 m (16.4 ft)	JZSP-CMM60-05	JZSP-CSM60-05	
			10 m (32.8 ft)	JZSP-CMM60-10	JZSP-CSM60-10	
			15 m (49.2 ft)	JZSP-CMM60-15	JZSP-CSM60-15	
			20 m (65.5 ft)	JZSP-CMM60-20	JZSP-CSM60-20	
	Without brakes (For middle- capacity series)	SGMCS-□□M,N		Cables with connectors and cables/ connector are not available. Contact your Yaskawa representative.		
	Servomotor end connector			JN1DS04FK1*2		Soldered 
	Cables	For SGMCS- □□B, C, D, E	5 m (16.4 ft)	JZSP-CSM90-05	JZSP-CSM80-05	20 m (65.6 ft) max. 
			10 m (32.8 ft)	JZSP-CSM90-10	JZSP-CSM80-10	
			15 m (49.2 ft)	JZSP-CSM90-15	JZSP-CSM80-15	
20 m (65.5 ft)			JZSP-CSM90-20	JZSP-CSM80-20		
③ Wires and Connectors for Relay Encoder Cable Extensions	Wires and connectors for relay encoder cable exten- sions are available for as- sembly by the customer.		30 m (98.4 ft)	JZSP-CMP19-30		50 m (164 ft) max. 
			40 m (131.2 ft)	JZSP-CMP19-40		
			50 m (164 ft)	JZSP-CMP19-50		



* 1. Use flexible cables for movable sections such as robot arms. Refer to 5.6 *Flexible Cables*.

* 2. Contact Japan Aviation Electronics Industry, Ltd.

2.5 Selecting Peripheral Devices

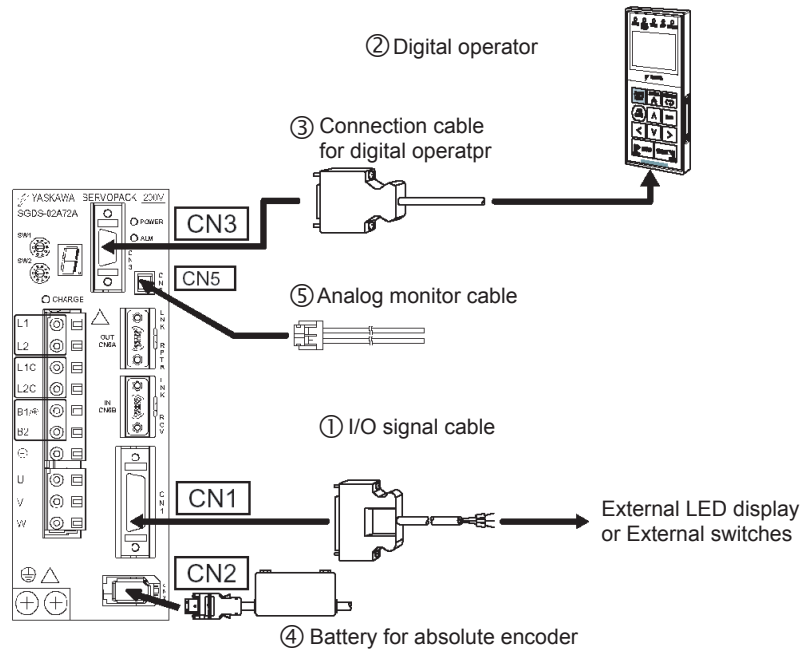
2.5.1 Special Options

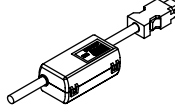
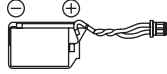
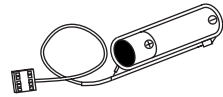

Name	Length	Type	Specifications
① CN1 I/O Signal Cables	Connector terminal block converter unit		Terminal block and 0.5 m to 2 m (1.640 ft to 6.562 ft) connection cable 
	1 m (3.28 ft)	JZSP-VJI01-1	Loose wires at customer end 
	2 m (6.56 ft)	JZSP-VJI01-2	
	3 m (9.84 ft)	JZSP-VJI01-3	
② Digital Operator		JUSP-OP05A	With a cable (1 m (3.28 ft))
⑤ CN5 Analog Monitor Cable	1 m (3.28 ft)	JZSP-CA01	SERVOPACK end 

Name	Type	Specifications
④ Battery for Absolute Encoder Note: No battery is mounted in the battery case. A battery must be purchased separately.	JUSP-BA01	Battery case 
	JZSP-BA01	(To mount in the battery case) 
	ER6VC3N	To connect to a host controller (provided by a customer) 3.6 V 2000 mAh, manufactured by Toshiba Battery Co., Ltd. 

2

2.5.2 Molded-case Circuit Breaker and Fuse Capacity

Main Circuit Power Supply	SERVOPACK Model		Power Supply Capacity per SERVOPACK (kVA)	Current Capacity of Breaker or Fuse (A_{rms})*1, *2
	Capacity (kW)	SGDS-		
Single-phase 100 V	0.05	A5F	0.25	4
	0.10	01F	0.40	
	0.20	02F	0.60	6
	0.40	04F	1.2	12
Single-phase 200 V	0.05	A5A	0.25	4
	0.10	01A	0.40	
	0.20	02A	0.75	
	0.40	04A	1.2	8
	0.75	08A	2.1	16
Three-phase 200 V	1.0	10A	2.3	7
	1.5	15A	3.2	10
	2.0	20A	4.3	13
	3.0	30A	5.9	17

* 1. Nominal value at the rated load. The specified derating is required to select an appropriate fuse capacity. Refer to 4.4.8 Molded-case Circuit Breaker (MCCB).

* 2. The cutoff characteristics (25°C): 200% two seconds min., 700% 0.01 seconds min.

Note: Do not use a fast-acting fuse. Because the SERVOPACK's power supply is a capacitor input type, a fast-acting fuse may blow when the power is turned ON.

IMPORTANT

The SGDS SERVOPACK does not include a protective grounding circuit. To ensure safety in the system, install a ground-fault protector against overloads and short-circuit, or a ground fault protector dedicated for protective grounding combined with the molded-case circuit breaker.

2.5.3 Noise Filters

Main Circuit Power Supply	SERVOPACK Model		Recommended Noise Filter *	
	Capacity (kW)	SGDS-	Type	Specifications
Single-phase 100 V	0.05	A5F	FN2070-6/07	Single-phase 250 VAC, 6 A
	0.10	01F		
	0.20	02F	FN2070-10/07	Single-phase 250 VAC, 10 A
	0.40	04F	FN2070-16/07	Single-phase 250 VAC, 16 A
Single-phase 200 V	0.05	A5A	FN2070-6/07	Single-phase 250 VAC, 6 A
	0.10	01A		
	0.20	02A		
	0.40	04A	FN2070-10/07	Single-phase 250 VAC, 10 A
	0.75	08A	FN2070-16/07	Single-phase 250 VAC, 16 A
Three-phase 200 V	1.0	10A	FN258L-16/07	Three-phase 480 VAC, 16 A
	1.5	15A		
	2.0	20A		
	3.0	30A	FN258L-30/07	Three-phase 480 VAC, 30 A

* Refer to 4.4.9 Noise Filter.

IMPORTANT**■ Noise Filter Brake Power Supply**

Use the following noise filter at the brake power input for 400 W or less servomotors with holding brakes.
MODEL: FN2070-6/07 (Manufactured by SCHAFFNER Electronic.)

2.5.4 Regenerative Resistors

Main Circuit Power Supply	SERVOPACK Model		Built-in Regenerative Resistor			Minimum Allowable Resistance (Ω)
	Capacity (kW)	SGDS-	Resistance (Ω)	Capacity (W)	Processable Electric Power * (W)	
Single-phase 100 V	0.05	A5F	-	-	-	40
	0.10	01F				
	0.20	02F				
	0.40	04F				
Single-phase 200 V	0.05	A5A	50	60	12	
	0.10	01A				
	0.20	02A				
	0.40	04A				
	0.75	08A				
Three-phase 200 V	1.0	10A	20	50	10	
	1.5	15A				
	2.0	20A	12	80	16	
	3.0	30A				

* The regenerative electric power (mean value) that can be processed is 20% of the capacity rating of the built-in regenerative resistor.

Note: 1. If the SERVOPACK cannot process the regenerative power, an external regenerative resistor is required. Refer to 4.4.6 *External Regenerative Resistor* and 5.5 *Connecting Regenerative Resistors*.

2. External regenerative resistor manufactured by Iwaki Wireless Research Institute.

IMPORTANT

■ Noise Filter Brake Power Supply

Use the following noise filter at the brake power input for 400 W or less servomotors with holding brakes.
MODEL: FN2070-6/07 (Manufactured by SCHAFFNER Electronic.)

SERVOPACK Specifications and Dimensional Drawings

3.1 SERVOPACK Ratings and Specifications	3-2
3.2 SERVOPACK Installation	3-4
3.3 SERVOPACK Internal Block Diagrams	3-6
3.3.1 Single-phase 100 V, 50 W to 400 W Models	3-6
3.3.2 Single-phase 200 V, 50 W to 400W Models	3-7
3.3.3 Three-phase 200 V, 1.0 kW Models	3-8
3.3.4 Single-phase 200 V, 750 W Model	3-9
3.3.5 Three-phase 200 V, 1.5 kW to 3.0 kW Models	3-10
3.4 SERVOPACK Power Losses	3-11
3.5 SERVOPACK Overload Characteristics and Load Moment of Inertia	3-12
3.5.1 Overload Characteristics	3-12
3.5.2 Starting and Stopping Time	3-13
3.5.3 Load Moment of Inertia	3-13
3.6 Dimensional Drawings of SERVOPACK Model	
SGDS-□□□72□	3-17
3.6.1 Classification table	3-17
3.6.2 Single-phase 100 V/200 V, 50 W/100 W/200 W	3-17
3.6.3 Single-phase 200 V, 400 W	3-18
3.6.4 Single-phase 100 V, 400 W	3-18
3.6.5 Single-phase 200 V, 750 W, and Three-phase 200 V, 1.0 kW	3-19
3.6.6 Three-phase 200 V, 1.5 kW	3-19
3.6.7 Three-phase 200 V, 2.0 kW / 3.0 kW	3-20

3.1 SERVOPACK Ratings and Specifications

SERVOPACK Model SGDS-			A5	01	02	04	08	10	15	20	30	
Max. Applicable Servomotor Capacity [kW]			0.05	0.1	0.2	0.4	0.75	1.0	1.5	2.0	3.0	
100 V	Continuous Output Current [Arms]		0.66	0.91	2.1	2.8	–	–	–	–	–	
	Max. Output Current [Arms]		2.1	2.8	6.5	8.5	–	–	–	–	–	
200 V	Continuous Output Current [Arms]		0.66	0.91	2.1	2.8	5.5	7.6	11.6	18.5	18.9	
	Max. Output Current [Arms]		2.1	2.8	6.5	8.5	16.9	17.0	28.0	42.0	56.0	
Input Power Supply	SERVOPACK Capacity Range	100 VAC	Single-phase				–					
		200 VAC	Single-phase				Single-phase	–				
			–				–	Three-phase				
	Main Circuit		Single or three-phase 200 to 230 VAC +10 to -15%, 50/60 Hz Single-phase 100 to 115 VAC +10 to -15%, 50/60 Hz									
	Control Circuit		Single-phase 200 to 230 VAC +10 to -15%, 50/60 Hz Single-phase 100 to 115 VAC +10 to -15%, 50/60 Hz									
Control Method			Single or three-phase full-wave rectification IGBT-PWM (sine-wave driven)									
Feedback			Serial encoder: 17-bit (incremental/absolute) Serial encoder: 20-bit (incremental/absolute)									
Operating Conditions	Ambient/Storage Temperature		0 to +55°C/ -20 to +85°C									
	Ambient/Storage Humidity		90% RH or less (with no condensation)									
	Vibration/Shock Resistance		4.9 m/s ² / 19.6 m/s ²									
Configuration			Base-mounted (Rack mounting available as an option)									
Performance	Speed Control Range		1:5000 (The lowest speed of the speed control range is the speed at which the servomotor will not stop with a rated torque load.)									
	Speed Regulation*	Load Regulation	0 to 100% load: 0.01% max. (at rated speed)									
		Voltage Regulation	Rated voltage ±10%: 0% (at rated speed)									
		Temperature Regulation	25 ± 25 °C: ±0.1% max. (at rated speed)									
	Frequency Characteristics		600 Hz (at $J_L = J_M$)									
	Torque Control Tolerance (Repeatability)		±1%									
Built-in Functions	Dynamic Brake (DB)		Operated at main power OFF, servo alarm, or servo OFF									
	Regenerative Processing		Externally mounted regenerative resistor				Built-in					
	Overtravel Prevention (OT)		CW-OT and CCW-OT signal input (processed by the host controller)									
	Protection		Overcurrent, overvoltage, insufficient voltage, overload, regeneration error, main circuit sensor error, heat sink overheat, power phase loss, overflow, overspeed, encoder error, overrun, CPU error, parameter error, etc.									
	LED Display		Device Status (7-segment LED), Charge, Power, Alarm, Link In, Link Out, Reporter, Receive									
	Others		Reverse connection, automatic motor discrimination function									

* Speed regulation is defined as follows:

$$\text{Speed regulation} = \frac{\text{No-load motor speed} - \text{Total load motor speed}}{\text{Rated motor speed}} \times 100\%$$

The motor speed may change due to voltage variations or amplifier drift and changes in processing resistance due to temperature variation. The ratio of speed changes to the rated speed represent speed regulation due to voltage and temperature variations.

Applicable SERVOPACK Model		SGDS-A5□72A to -30□72A: For All Capacities	
SynqNet Communications	Baud Rate	100 Mbps	
	Transmission Cycle	Multiple of 62.5 μs (set by the host controller)	
	Address Setting	Select the address of 0 to 255 with using the rotary switch.	
Reference Method	Operating Specifications	Torque control with using SynqNet communication	
	Reference Input	SynqNet communication Command: Torque reference	
	Fully-closed Control	Fully-closed input (controlled by the host controller)	
Built-in Functions	Analog Monitor (CN5)		
	Analog monitor connector built in for monitoring speed, torque. Speed: 1 V/1000 min ⁻¹ Torque: 1 V/rated torque		
	Communications	Interface	Digital operator (hand held type) via RS422A port or personal computer via RS232C port
		Axis Address Setting	Parameter
Functions		Status display, user constant setting, monitor display, alarm display, JOG driving, speed and torque instruction signals, etc.	

3.2 SERVOPACK Installation

The SGDS SERVOPACKs can be mounted on a base or on a rack. Incorrect installation will cause problems. Always observe the following installation instructions.

WARNING

- Do not touch terminals for five minutes after voltage resistance test. (Refer to *Voltage Resistance Test* on the next page.)
Residual voltage may cause electric shock.
- Connect the main circuit wires, control wires, and main circuit cables of the motor correctly.
Incorrect wiring will result in failure of the SERVOPACK.

Storage	Store the SERVOPACK within the following temperature range if it is stored with the power cable disconnected. Temperature: -20 to 85°C (-4 to 185°F) Humidity: 90%RH or less (with no condensation)
Operating Conditions	<ul style="list-style-type: none"> • Installation category (Overvoltage category) * : II • Pollution degree * : 2 • Protection class * : 1X • Altitude : 1000 m max. <p>* Conforming to the following standards. Certification is pending for the following standards.</p> <ul style="list-style-type: none"> • UL508C • CSA C22.2 No.14 • EN50178 • EN55011 group 1 class A • EN61000-6-2
Installation Site	<p>Installation in a Control Panel Design the control panel size, unit layout, and cooling method so the temperature around the SERVOPACK does not exceed 55 °C (131 °F).</p> <p>Installation Near a Heating Unit Minimize the heat radiating from the heating unit as well as any temperature rise caused by natural convection so the temperature around the SERVOPACK does not exceed 55 °C (131 °F).</p> <p>Installation Near a Source of Vibration Install a vibration isolator beneath the SERVOPACK to avoid subjecting it to vibration.</p> <p>Installation at a Site Exposed to Corrosive Gas Corrosive gas does not have an immediate effect on the SERVOPACK but will eventually cause the electronic components and contactor-related devices to malfunction. Take appropriate action to avoid corrosive gas.</p> <p>Other Situations Do not install the SERVOPACK in hot, humid locations or locations subject to excessive dust or iron powder in the air.</p>

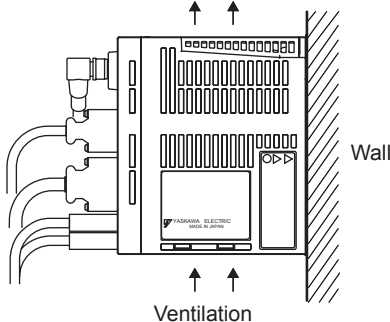
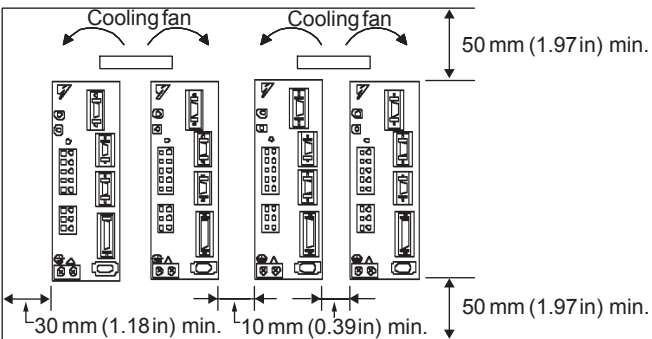
<p>Orientation</p>	<p>Install the SERVOPACK perpendicular to the wall as shown in the figure. The SERVOPACK must be oriented this way because it is designed to be cooled by natural convection or a cooling fan.</p> <p>Secure the SERVOPACK using two to four of the mounting holes. The number of holes depends on the capacity.</p> 
<p>Installation</p>	<p>Follow the procedure below to install multiple SERVOPACKs side by side in a control panel.</p>  <p>SERVOPACK Orientation</p> <p>Install the SERVOPACK perpendicular to the wall so the front panel containing connectors faces outward.</p> <p>Cooling</p> <p>As shown in the figure above, allow sufficient space around each SERVOPACK for cooling by cooling fans or natural convection.</p> <p>Side-by-side Installation</p> <p>When installing SERVOPACKs side by side as shown in the figure above, allow at least 10 mm (0.39 in) between and at least 50 mm (1.97 in) above and below each SERVOPACK. Install cooling fans above the SERVOPACKs to avoid excessive temperature rise and to maintain even temperature inside the control panel.</p> <p>Environmental Conditions in the Control Panel</p> <ul style="list-style-type: none"> Ambient Temperature: 0 to 55°C (32 to 131° F) Humidity: 90% RH or less Vibration: 0.5 G (4.9 m/s²) Condensation and Freezing: None Ambient Temperature for Long-term Reliability: 45°C (113 °F) max.
<p>Voltage Resistance Test</p>	<p>Conduct voltage resistance tests under the following conditions.</p> <ul style="list-style-type: none"> • Voltage: 1500 Vrms AC for one minute • Braking current: 30 mA or more • Frequency: 50 or 60 Hz • For SGDS-□□□72A SERVOPACKs: Between the ground terminals and the point where the terminals L1, L2, (L3), L1C, L2C, U, V, and W are connected.

3.3 SERVOPACK Internal Block Diagrams

3.3.1 Single-phase 100 V, 50 W to 400 W Models

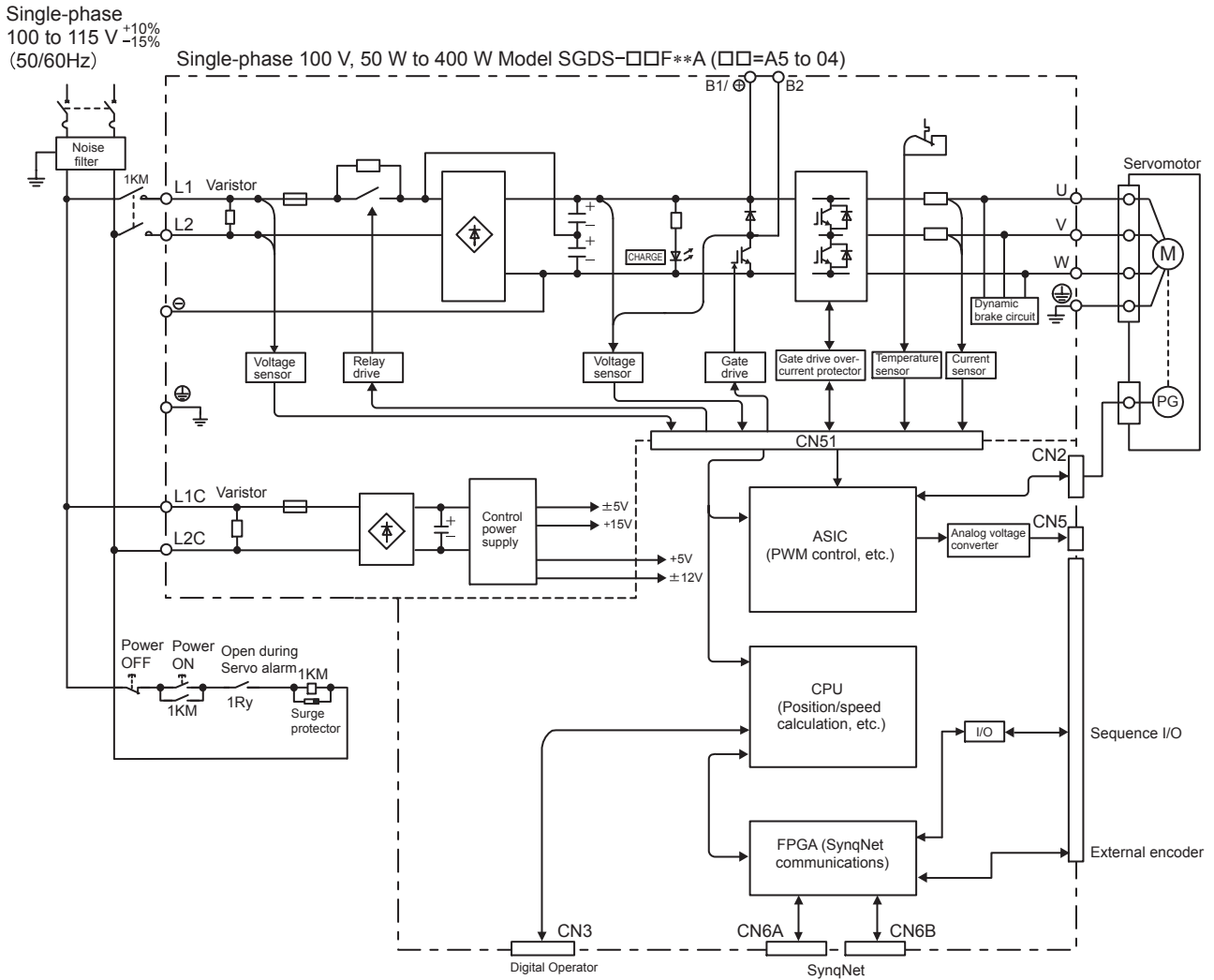

3.3.2 Single-phase 200 V, 50 W to 400W Models

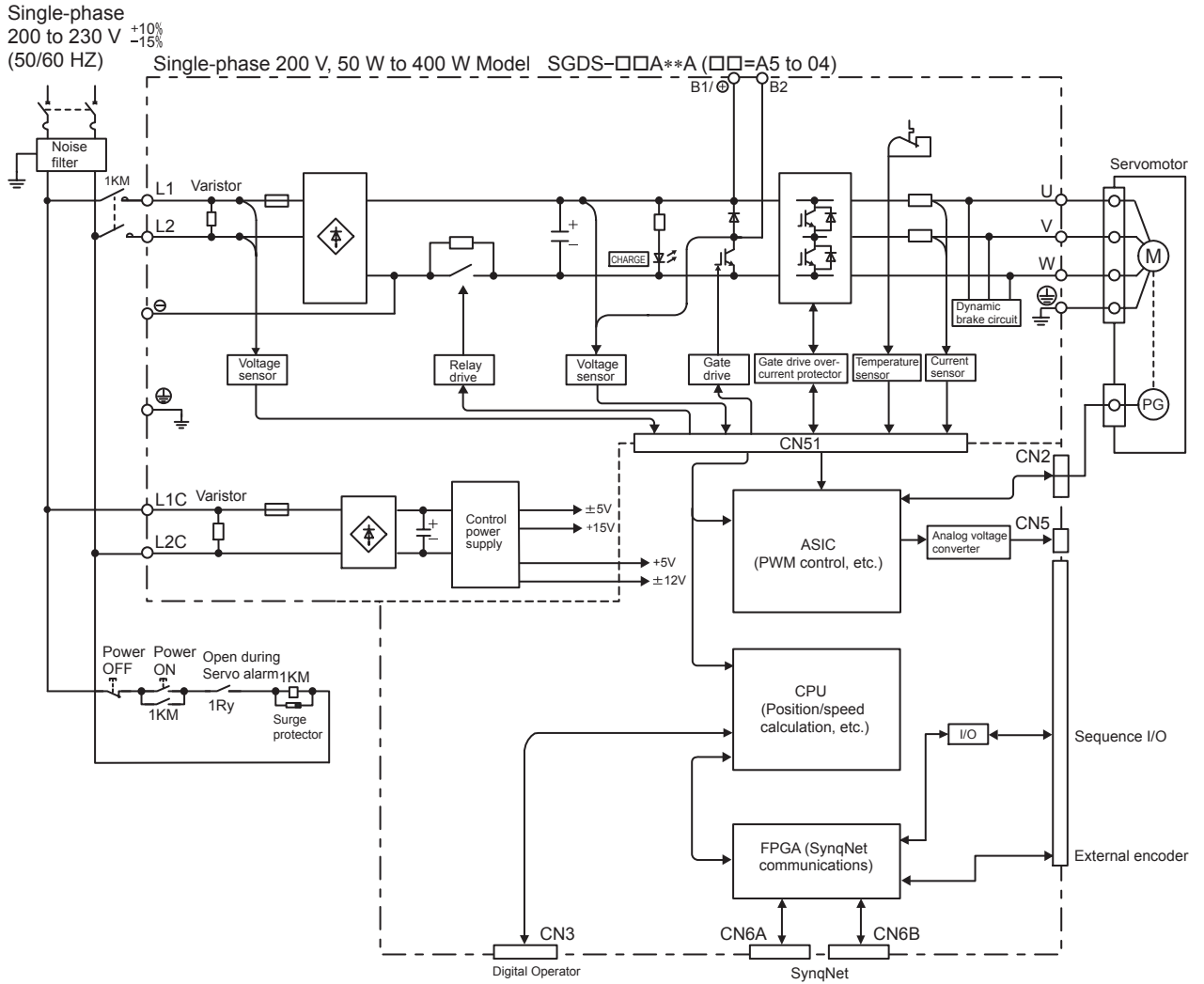

3

3.3.3 Three-phase 200 V, 1.0 kW Models

Three-phase
200 to 230 V $+10\%$ -15% Three-phase 200 V, 1.0 kW Model SGDS-□□A**A (□□=10)
(50/60 Hz)

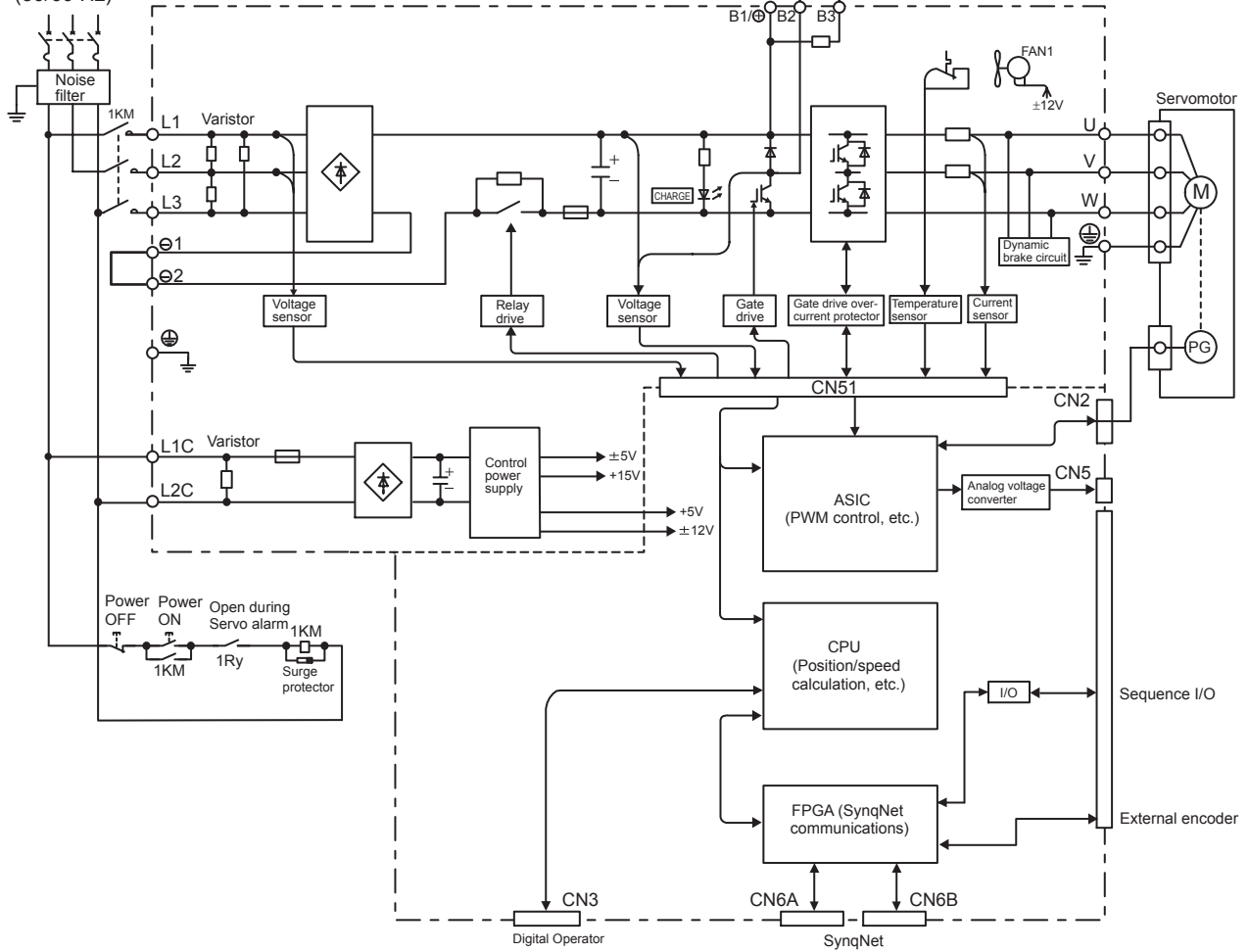

3.3.4 Single-phase 200 V, 750 W Model

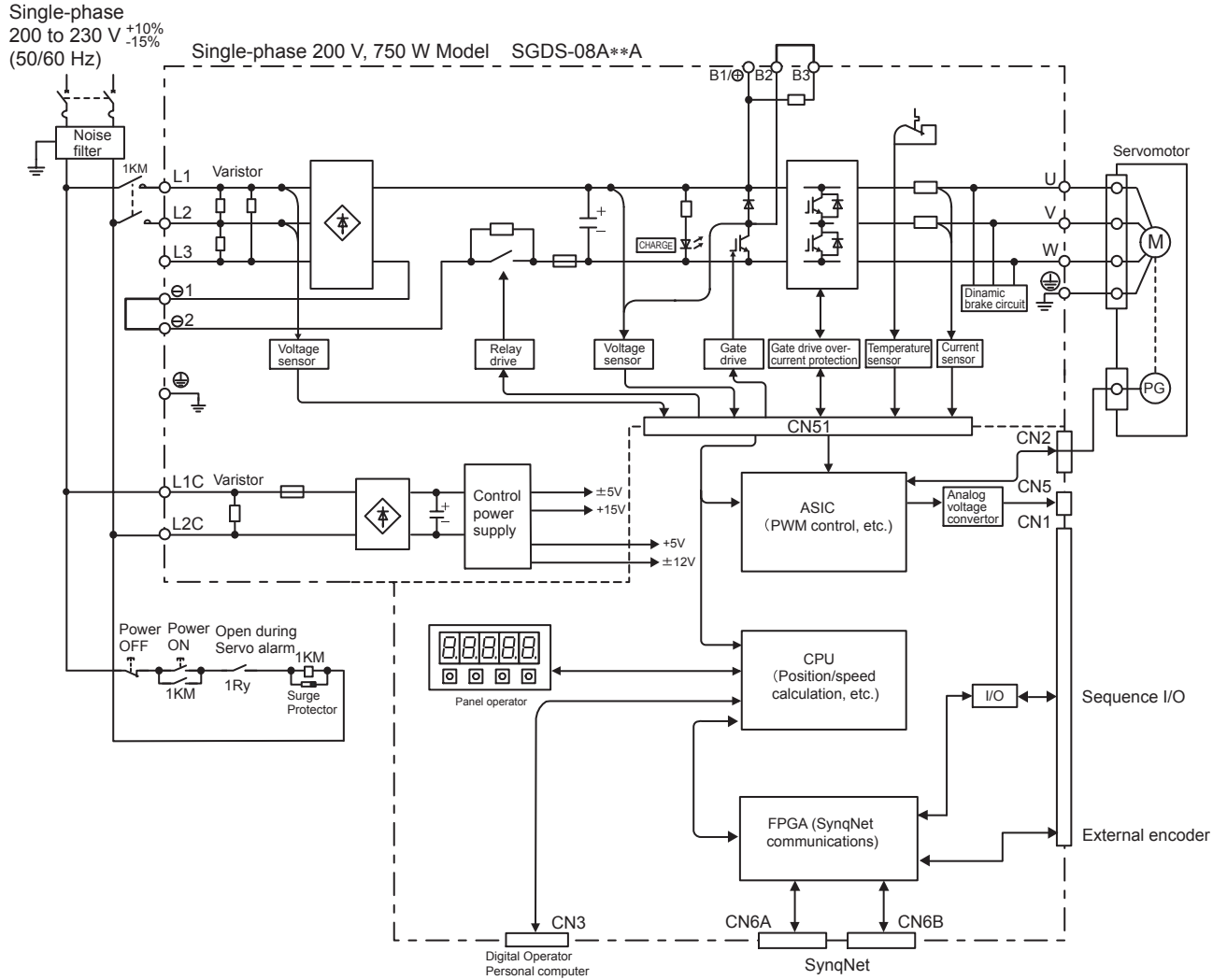

Note: L3 terminal is not used. Do not connect.

3.3.5 Three-phase 200 V, 1.5 kW to 3.0 kW Models

3.3.5 Three-phase 200 V, 1.5 kW to 3.0 kW Models

Three-phase 200 to 230 V^{+10%}/_{-15%} (50/60 Hz) Three-phase 200 V, 1.5 kW to 3.0 kW Model SGDS-□□A**A (□□=15 to30)

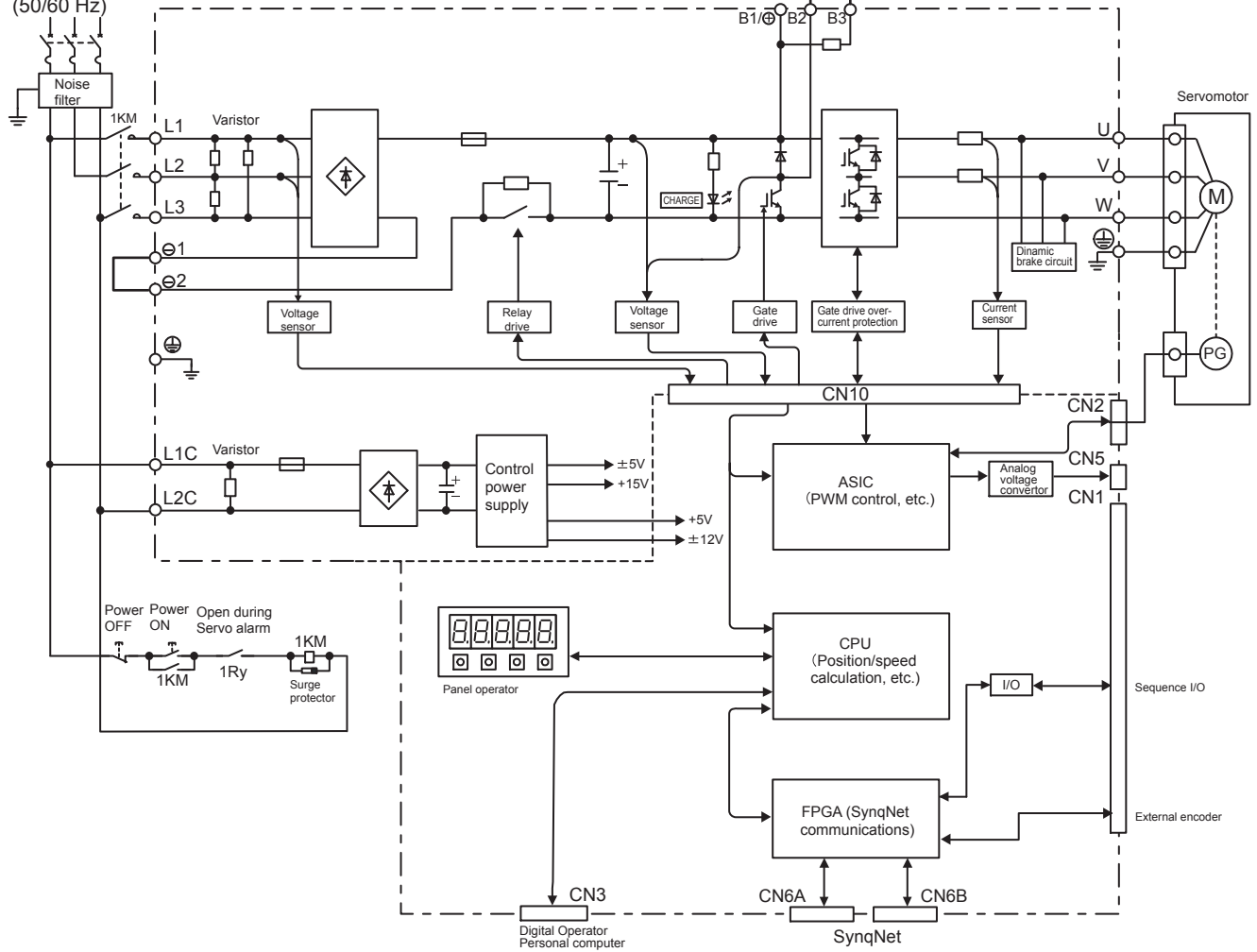

3.4 SERVOPACK Power Losses

The following table shows SERVOPACK power losses at the rated output.

SERVOPACK Power Losses at Rated Output

Main Circuit Power Supply	Maximum Applicable Servomotor Capacity (kW)	SERVOPACK Model SGDS-	Output Current (Effective Value) (A)	Main Circuit Power Loss (W)	Regenerative Resistor Power Loss (W)	Control Circuit Power Loss (W)	Total Power Loss (W)	
Single-phase 100V	0.05	A5F	0.66	5.2	*1	13	18.2	
	0.10	01F	0.91	12			25	
	0.20	02F	2.1	16.4			29.4	
	0.40	04F	2.8	24			37	
Single-phase 200V	0.05	A5A	0.64	4.6			17.6	
	0.10	01A	0.91	6.7			19.7	
	0.20	02A	2.1	13.3			26.3	
	0.40	04A	3.8	27			40	
	0.75	08A	5.5	47		74		
Three-phase 200V	1.0	10A	7.6	55		12	15	82
	1.5	15A	11.6	92		14		121
	2.0	20A	18.5	120		28		163
	3.0	30A	18.9	155		28		198

* 1. SERVOPACKs with a capacity of 50 to 400 W do not have built-in regenerative resistors. If the regenerative energy exceeds the specified value, connect an external regenerative resistor.

* 2. Regenerative resistor power losses are allowable losses. Take the following action if this value is exceeded.

- Remove the lead from the internal regenerative resistor in the SERVOPACK.
- Install an external regenerative resistor.

Note: External regenerative resistors are optional. Refer to 5.5 *Connecting Regenerative Resistors* and 4.4.6 *External Regenerative Resistor* for details.

3.5 SERVOPACK Overload Characteristics and Load Moment of Inertia

3.5.1 Overload Characteristics

The overload detection level is set under hot start conditions at a servomotor ambient temperature of 40°C (104°F).

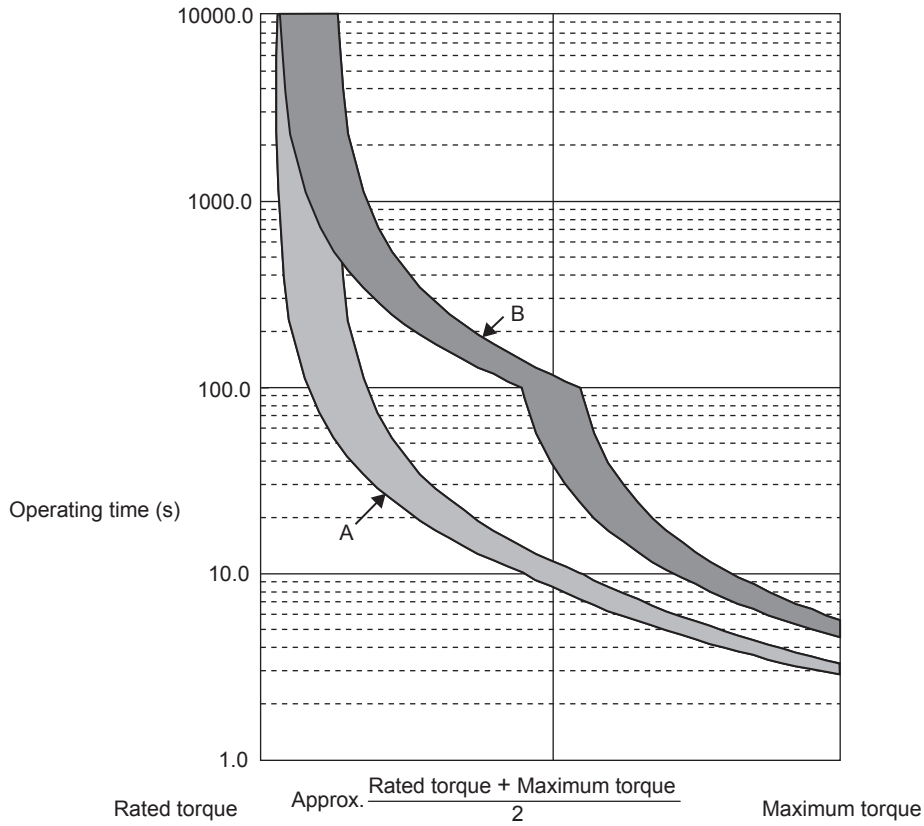

Note: The overload protection characteristics of A and B in the figure are applicable when the SERVOPACK is combined with one of the following servomotors.

Graph	Servomotor Model			
	SGMAS	SGMPS	GMSS	SGMCS
A	-A5 to 04	-01 to -04	-	-02 to -35
B	-06 to -12	-08 to -15	-10 to -30	-45 to 2Z

3.5.2 Starting and Stopping Time

The motor starting time (t_r) and stopping time (t_f) under a constant load are calculated using the following formulas. Motor viscous torque and friction torque are ignored.

$$\text{Starting time: } t_r = \frac{2\pi \cdot N_M (J_M + J_L)}{60 \cdot (T_{PM} - T_L)} [\text{s}]$$

$$\text{Stopping time: } t_f = \frac{2\pi \cdot N_M (J_M + J_L)}{60 \cdot (T_{PM} + T_L)} [\text{s}]$$

N_M : Motor speed (min^{-1})

J_M : Motor rotor moment of inertia ($\text{kg} \cdot \text{m}^2$)

J_L : Load converted to shaft moment of inertia ($\text{kg} \cdot \text{m}^2$)

T_{PM} : Instantaneous peak motor torque when combined with a SERVOPACK ($\text{N} \cdot \text{m}$)

T_L : Load torque ($\text{N} \cdot \text{m}$)

Calculate the torque from the motor current using servomotor torque constant \times motor current (effective value).

The following figure shows the motor torque and motor speed timing chart.

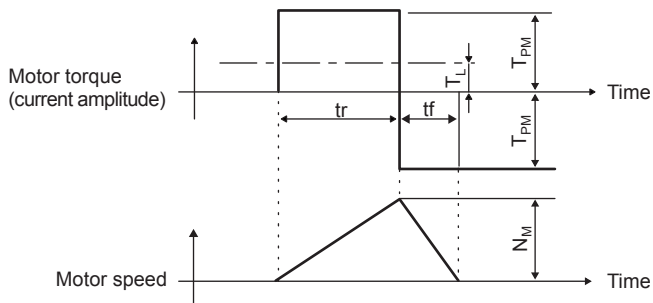

3.5.3 Load Moment of Inertia

The size of the allowable load moment of inertia of a servomotor depends on the capacity, and is limited to 5 to 30 times the motor inertia. This value is provided strictly as a guideline and results may vary depending on servomotor drive conditions.

An overvoltage alarm is likely to occur during deceleration if the load moment of inertia exceeds the allowable load moment of inertia. SERVOPACKs with a built-in regenerative resistor may generate a regeneration overload alarm. Take one of the following steps if this occurs.

- Reduce the torque limit.
- Reduce the deceleration rate.
- Reduce the maximum motor speed.
- Install an externally mounted regenerative resistor if the alarm cannot be cleared. Contact your Yaskawa Application Engineering Department.

Regenerative resistors are not built into 200 V for 50 W to 400 W and 100 V for 50 W to 400 W SERVOPACKs. The following figures show the tentative relationship between the load moment of inertia and motor speed using an example with a load moment of inertia 10 to 30 times the load moment of inertia at the motor shaft.

External regenerative resistors are required when this condition is exceeded or if the allowable loss capacity (W) of the built-in regenerative resistor is exceeded due to regenerative drive conditions when a regenerative resistor is already built in.

3.5.3 Load Moment of Inertia

(1) Load Moment of Inertia and Motor Speed for SGMAS Servomotors

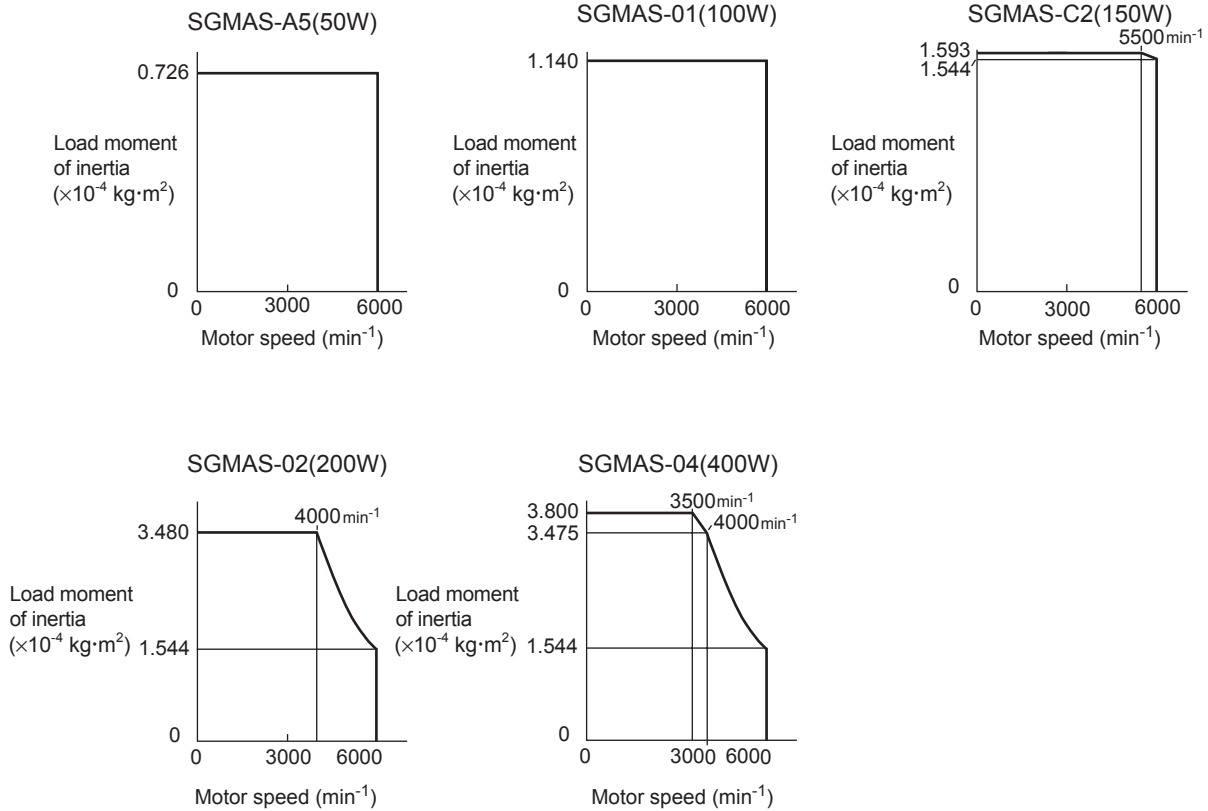

(2) Load Moment of Inertia and Motor Speed for SGMP S Servomotors

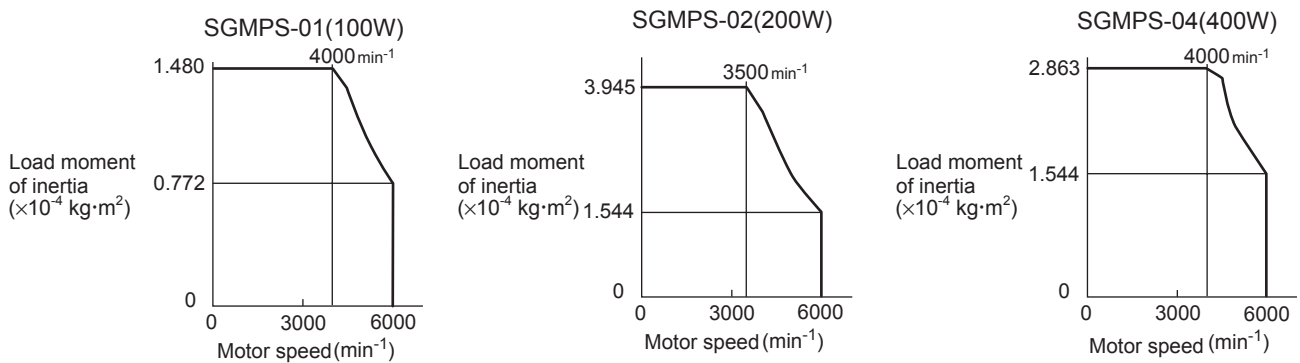

(3) Load Moment of Inertia and Motor Speed for SGMCS Servomotors

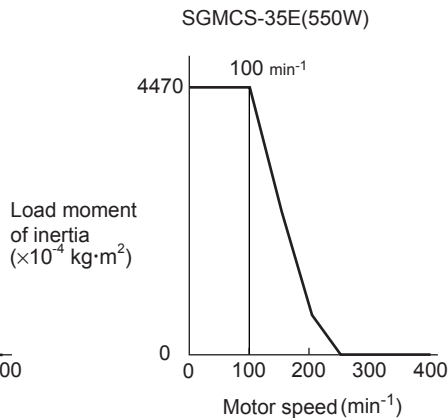
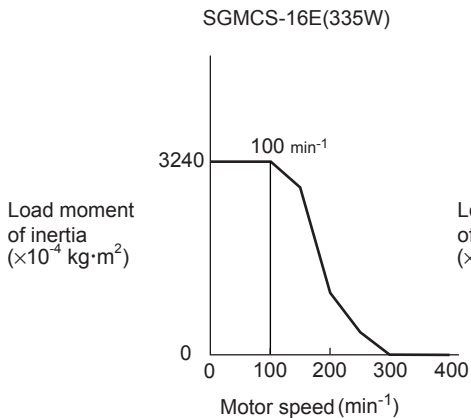
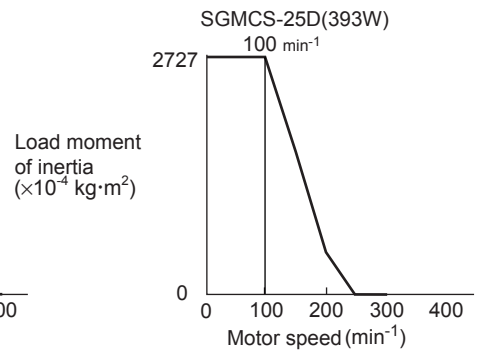
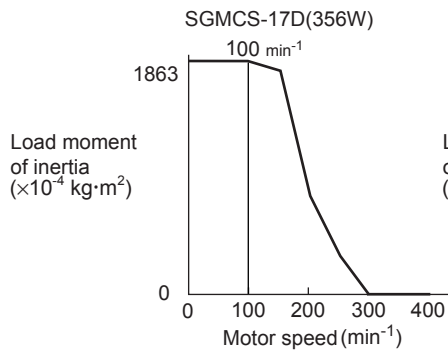
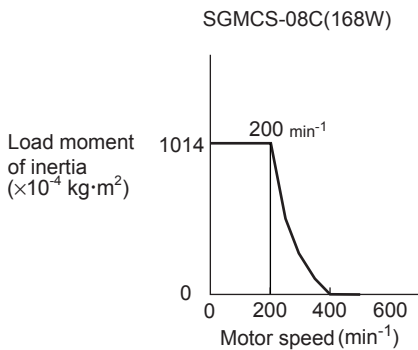
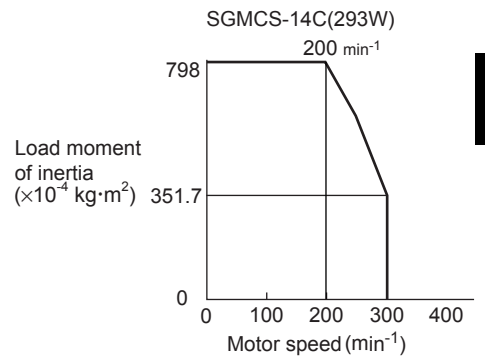
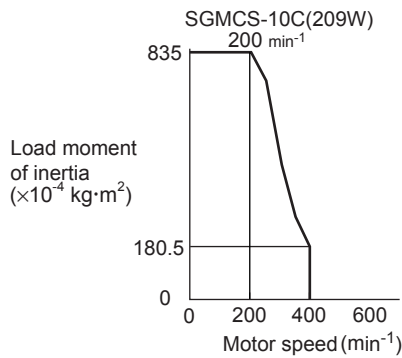
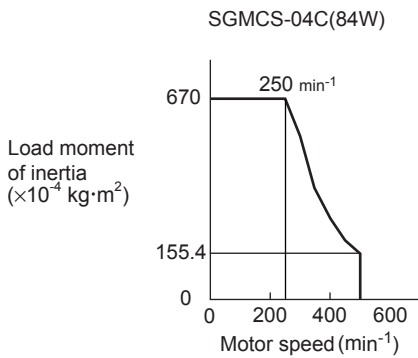
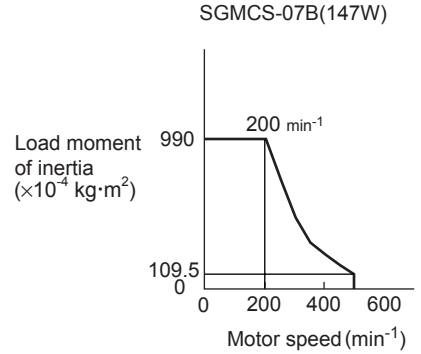
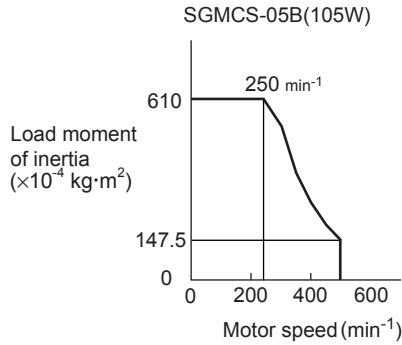
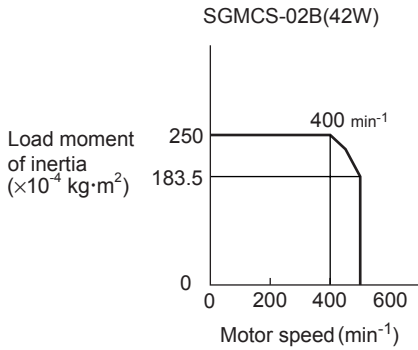

3

(4) Allowable Load Moment of Inertia at the Motor Shaft

The rotor moment of inertia ratio is the value for a servomotor without a gear and a brake.

Servomotor Model	Capacity Range	Allowable Load Moment of Inertia (Rotor Moment of Inertia Ratio)
SGMAS (200 V)	50 W to 200 W	× 30
	400 W to 750 W	× 20
	1.2 kW	× 10
SGMPS (200 V)	100 W	× 25
	200 W	× 15
	400 W	× 7
	750 W	× 5
	1.5 kW	× 5
SGMSS (200 V)	1.0 kW	× 5
	1.5 kW	× 5
	2.0 kW	× 5
	2.5 kW	× 5
	3.0 kW	× 5

Servomotor Model	Rated Output (N·m)	Allowable Load Moment of Inertia (Rotor Moment of Inertia Ratio)
SGMCS (200 V)	2.0, 4.0, 5.0, 7.0	× 10
	10.0	× 5
	8.0, 14.0, 16.0, 17.0, 25.0, 35.0	× 3
	45.0	× 3
	80.0	× 3
	110.0	× 3
	150.0	× 3
	200.0	× 3

3.6 Dimensional Drawings of SERVOPACK Model SGDS-□□□72□

3.6.1 Classification table

SERVOPACK dimensional drawings are grouped according to the mounting method and capacity.

- Base-mounted type

Power Supply Voltage	Capacity	Width [mm]	Height [mm]	Depth [mm]	Volume [mm ³]	Reference Section
Single-phase 100 V	50 W	55	150	130	1073	3.6.2
	100 W					
	200 W	70			1463	3.6.3
	400 W					
Single-phase 200 V	50 W	55	150	130	1073	3.6.2
	100 W					
	200 W	75			1463	3.6.3
	400 W					
	750 W					
Three-phase 200 V	1.0 kW	70	150	180	1890	3.6.4

3

3.6.2 Single-phase 100 V/200 V, 50 W/100 W/200 W

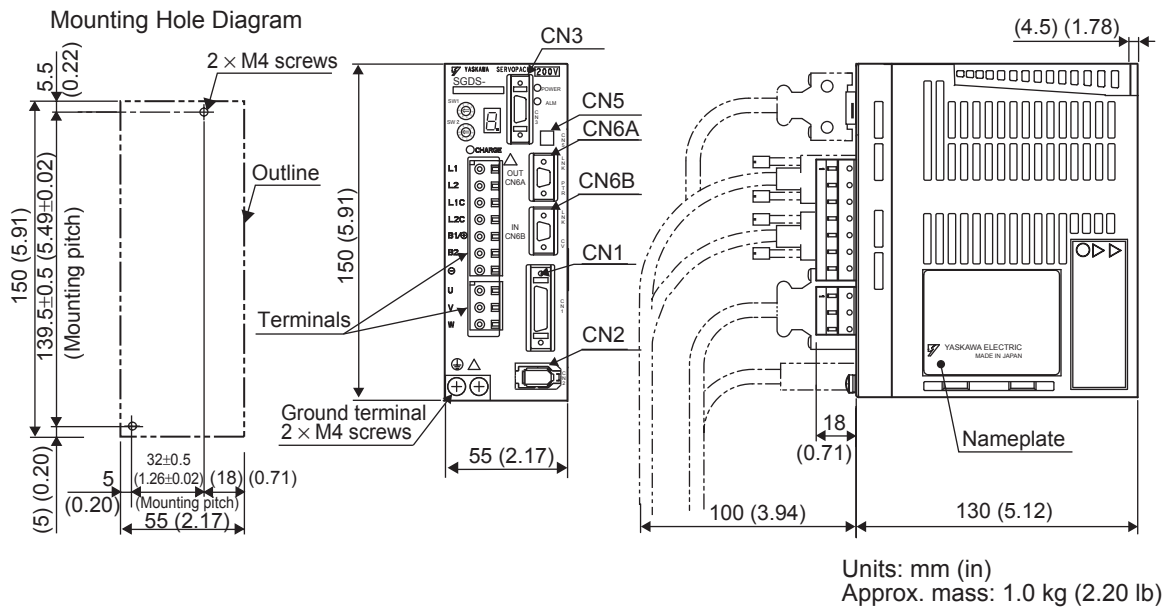

3.6.3 Single-phase 200 V, 400 W

3.6.3 Single-phase 200 V, 400 W

Mounting Hole Diagram

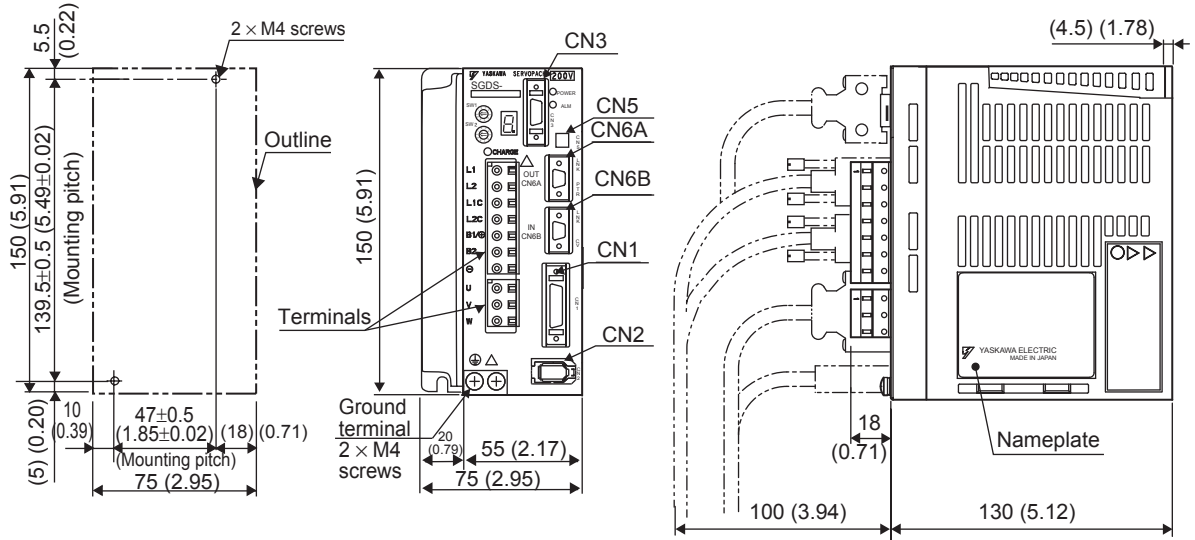

Units: mm (in)
Approx. mass: 1.4 kg (3.09 lb)

3.6.4 Single-phase 100 V, 400 W

Mounting Hole Diagram

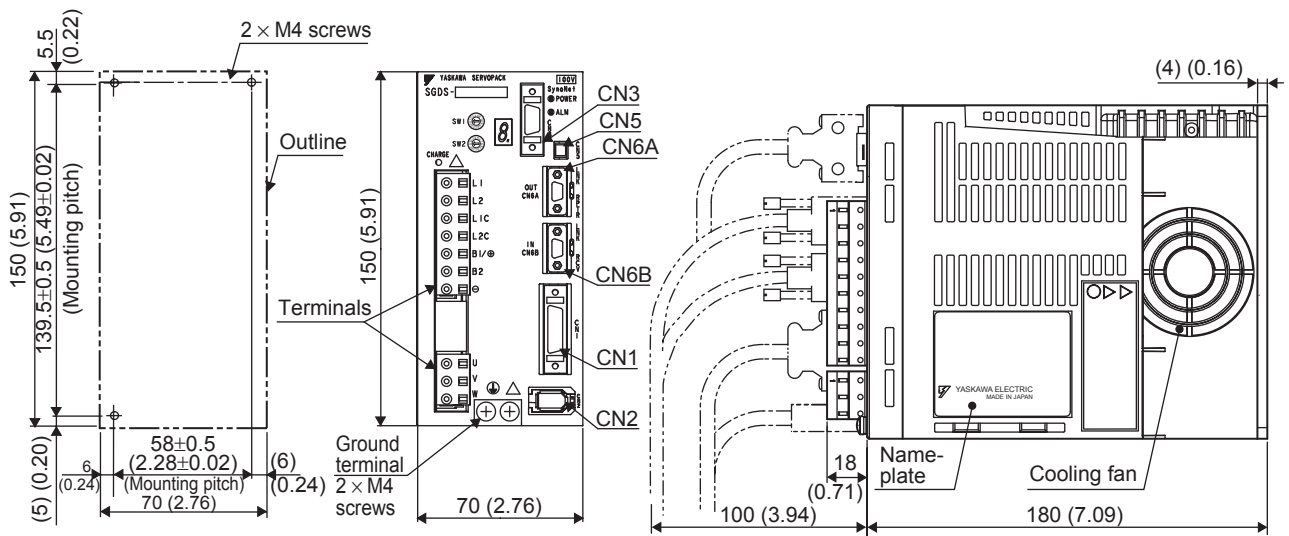

Units: mm (in)
Approx. mass: 1.2 kg (2.65 lb)

3.6.5 Single-phase 200 V, 750 W, and Three-phase 200 V, 1.0 kW

Mounting Hole Diagram

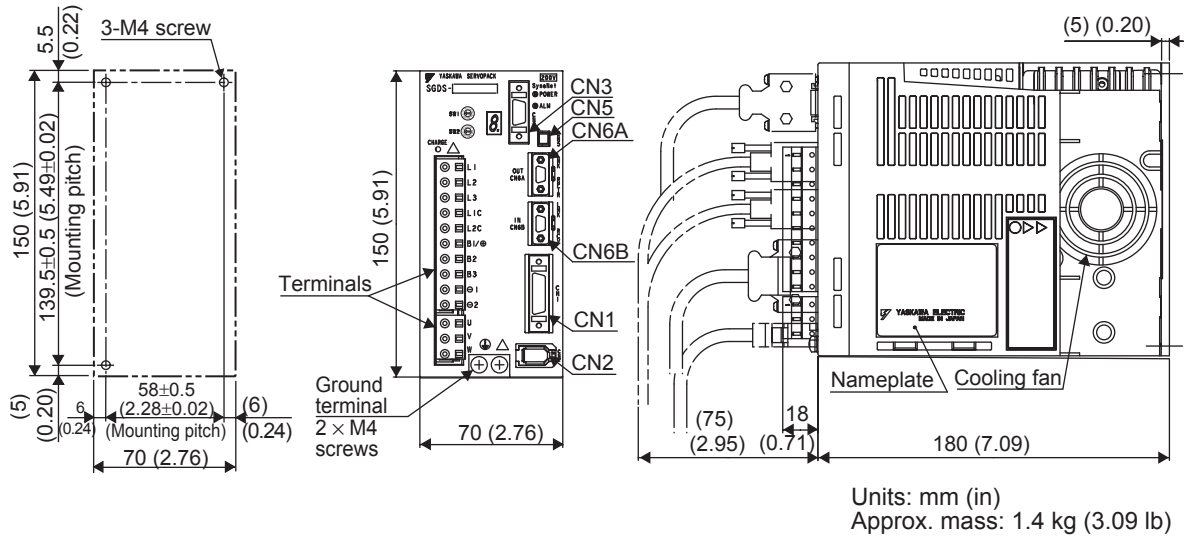

3.6.6 Three-phase 200 V, 1.5 kW

Mounting Hole Diagram

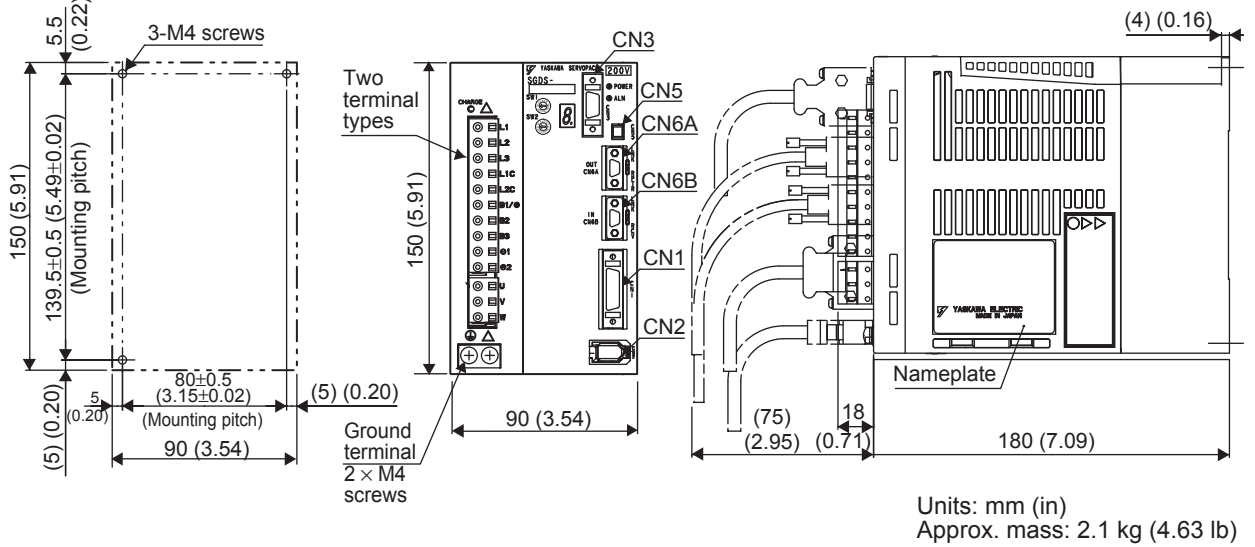

3.6.7 Three-phase 200 V, 2.0 kW / 3.0 kW

Mounting Hole Diagram

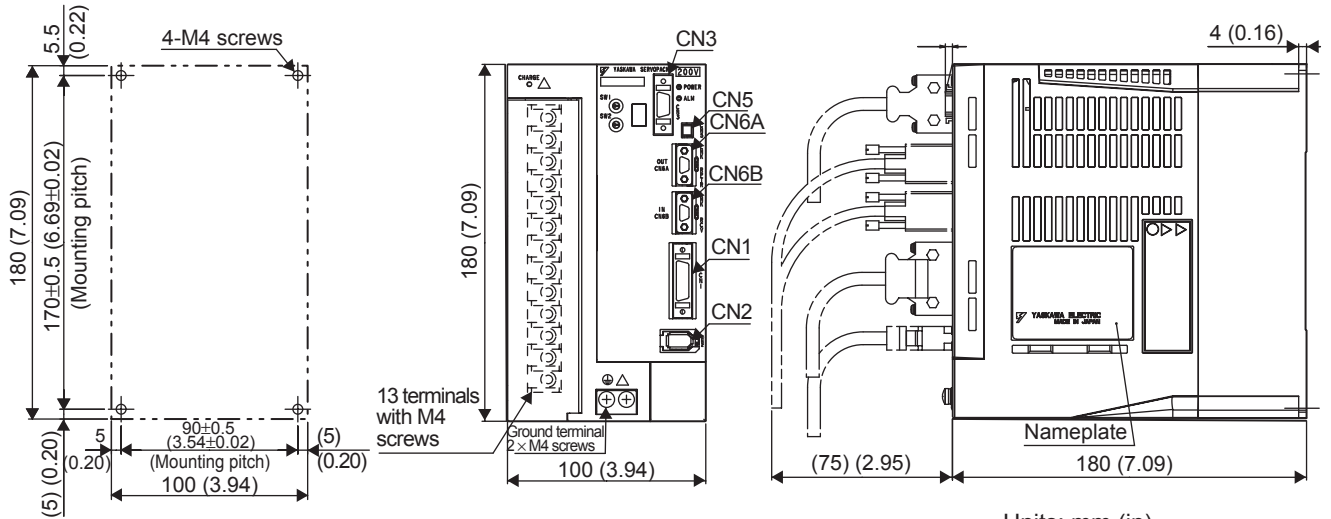

Units: mm (in)
 Approx. mass: 2.8 kg (6.17 lb)

Specifications and Dimensional Drawings of Cables and Peripheral Devices

4.1 SERVOPACK Main Circuit Wire Size	4-2
4.2 Connectors for Main Circuit, Control Power Supply, and Servomotor Cable	4-4
4.2.1 Spring Type (Standard)	4-4
4.2.2 Crimp Type (Option)	4-5
4.3 CN1 Cables for I/O Signals	4-6
4.3.1 Standard Cables	4-6
4.3.2 Connector Type and Cable Size	4-6
4.4 Peripheral Devices	4-8
4.4.1 Cables for Connecting Personal Computers	4-8
4.4.2 Digital Operator	4-8
4.4.3 Cables for Analog Monitor	4-8
4.4.4 Connector Terminal Block Converter Unit	4-9
4.4.5 Brake Power Supply Unit	4-10
4.4.6 External Regenerative Resistor	4-11
4.4.7 Absolute Encoder Battery	4-13
4.4.8 Molded-case Circuit Breaker (MCCB)	4-14
4.4.9 Noise Filter	4-15
4.4.10 Magnetic Contactor	4-18
4.4.11 Surge Protector	4-20
4.4.12 AC/DC Reactors for Harmonic Suppression	4-21

4.1 SERVOPACK Main Circuit Wire Size

IMPORTANT

1. Wire sizes were selected for three cables per bundle at 40°C (104 °F) ambient temperature with the rated current.
2. Use cable with a minimum dielectric withstand voltage of 600 V for main circuits.
3. If cables are bundled in PVC or metal ducts, consider the reduction ratio of the allowable current.
4. Use heat-resistant cable under high ambient or panel temperatures where normal vinyl cable will rapidly deteriorate.
5. Use cable within the allowable moment of inertia.
6. Do not use in continuous regenerating mode.

(1) Single-phase for 100 V

External Terminal Name	Terminal Symbol	SERVOPACK Model SGDS-			
		A5F	01F	02F	04F
Main circuit power input terminals	L1, L2	HIV1.25		HIV2.0	
Servomotor connection terminals	U, V, W	HIV1.25			
Control power input terminals	L1C, L2C	HIV1.25			
External regenerative resistor connection terminals	B1/⊕, B2	HIV1.25			
Ground terminal	⊖	HIV2.0 min.			

(2) Single-phase for 200 V

External Terminal Name	Terminal Symbol	SERVOPACK Model SGDS-				
		A5A	01A	02A	04A	08A
Main circuit power input terminals	L1, L2	HIV1.25			HIV2.0	
Servomotor connection terminals	U, V, W	HIV1.25				
Control power input terminals	L1C, L2C	HIV1.25				
External regenerative resistor connection terminal	B1/⊕, B2	HIV1.25				
Ground terminal	⊖	HIV2.0 min.				

(3) Three-phase for 200 V

External Terminal Name	Terminal Symbol	SERVOPACK Model SGDS-			
		10A	15A	20A	30A
Main circuit power input terminals	L1, L2, L3	HIV2.0		HIV3.5	
Servomotor connection terminals	U, V, W	HIV2.0		HIV3.5	HIV5.5
Control power input terminals	L1C, L2C	HIV1.25			
External regenerative resistor connection terminals	B1/⊕, B2	HIV1.25		HIV2.0	HIV3.5
Ground terminal	⊖	HIV2.0 min.			

(4) Cable Types

Cable Types		Allowable Conductor Temperature °C
Symbol	Name	
PVC	Normal vinyl cable	–
IV	600-V vinyl cable	60
HIV	Temperature-resistant vinyl cable	75

The wire size and allowable current for a three-conductor cable is shown in the table. Use a cable whose specifications meet or are less than the values in the table.

- 600 V Heat-resistant Vinyl Cable (HIV)

AWG size	Nominal Cross Section Diameter (mm ²)	Configuration (number of wires/mm ²)	Conductive Resistance (Ω/km)	Allowable Current at Ambient Temperatures (A)		
				30°C (86° F)	40°C (104° F)	50°C (122° F)
20	0.5	19/0.18	39.5	6.6	5.6	4.5
–	0.75	30/0.18	26.0	8.8	7.0	5.5
18	0.9	37/0.18	24.4	9.0	7.7	6.0
16	1.25	50/0.18	15.6	12.0	11.0	8.5
14	2.0	7/0.6	9.53	23	20	16
12	3.5	7/0.8	5.41	33	29	24
10	5.5	7/1.0	3.47	43	38	31
8	8.0	7/1.2	2.41	55	49	40
6	14.0	7/1.6	1.35	79	70	57

Note: The values in the table are only for reference.

4.2.1 Spring Type (Standard)

4.2 Connectors for Main Circuit, Control Power Supply, and Servomotor Cable

4.2.1 Spring Type (Standard)

Spring-type connectors are provided on SERVOPACK as standard.

(1) Connector Types

Appearance	Type	Manufacturer
3-pole (For servomotor main circuit cable connector at SERVOPACK end)	51446-0301	Molex Japan Co., Ltd.
7-pole (For 50 to 400 W SERVOPACKs)	51446-0701	
10-pole (For 750 W to 1.5 kW SERVOPACKs)	51446-1001	
Connection lever	54932-0000	

(2) External View and Dimensions

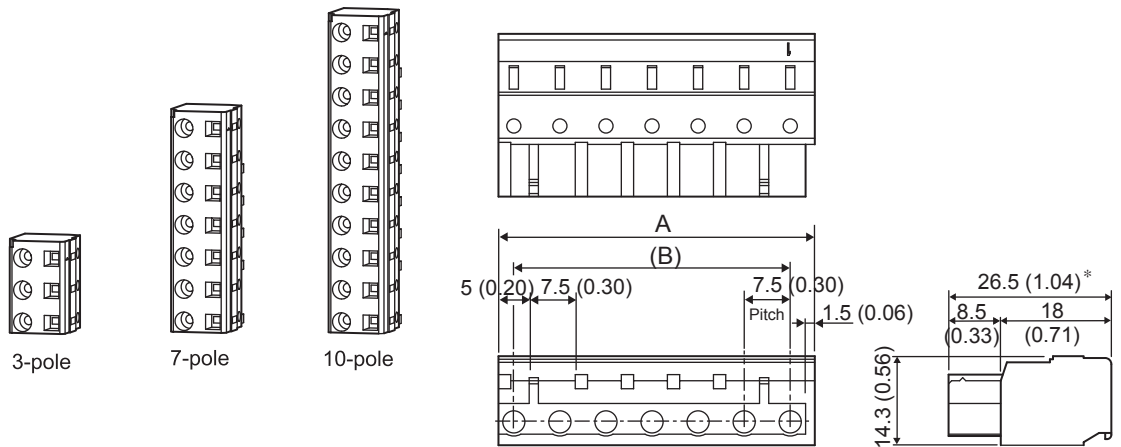

The Number of Poles	Dimension A	Dimension B
3	21.5 (0.85)	15 (0.59)
7	51.5 (2.03)	45 (1.77)
10	74 (2.91)	67.5 (2.66)

Units: mm (in)

(3) Connection Lever

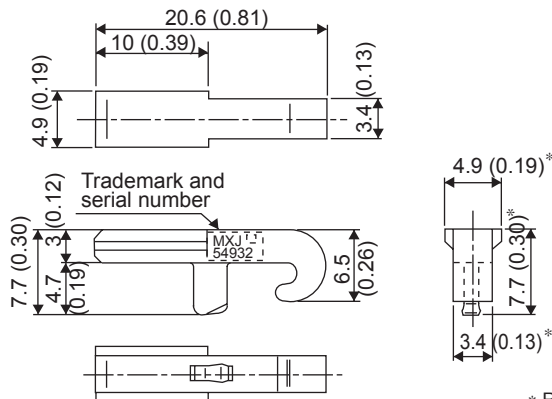

* Reference length
Units: mm (in)

4.2.2 Crimp Type (Option)

The crimp type connectors are options. Contact the manufacturer for details.

(1) Connector Types

Appearance	Types	Manufacturer
3-pole (For servomotor main circuit cable connector at SERVOPACK end)	51241-0311	Molex Japan Co., Ltd.
7-pole (For 50 to 400 W SERVOPACKs)	51241-0711	
10-pole (For 750 kW to 1.5 kW SERVOPACKs)	51241-1011	
Plug (chained)	56125-0018	
Plug (detached)	56125-0118	
Crimping tool	57349-5300	
Pull tool	57349-6000	

(2) External View and Dimensions

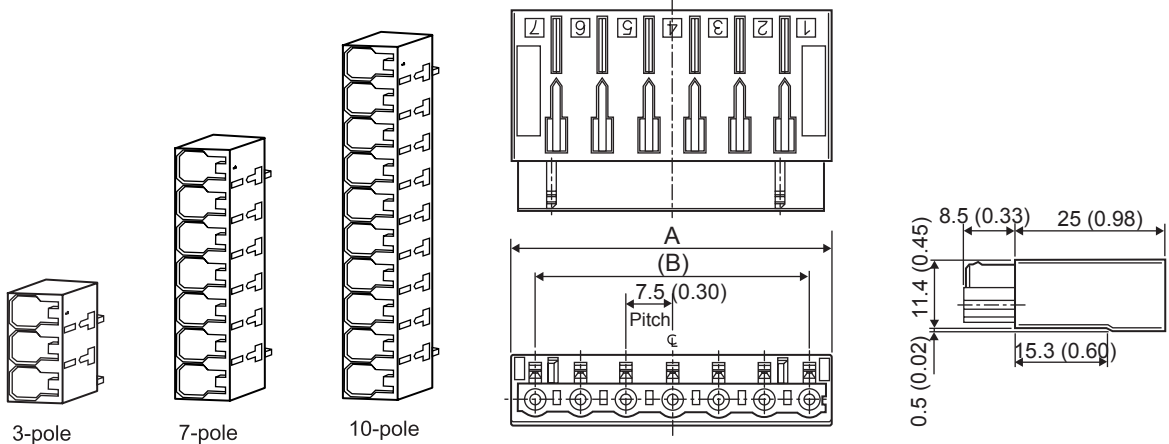

The Number of Poles	Dimension A	Dimension B
3	22.8 (0.90)	15 (0.59)
7	52.8 (2.08)	45 (1.77)
10	75.3 (2.96)	67.5 (2.66)

Units: mm (in)

(3) Plugs (Chained/Detached)

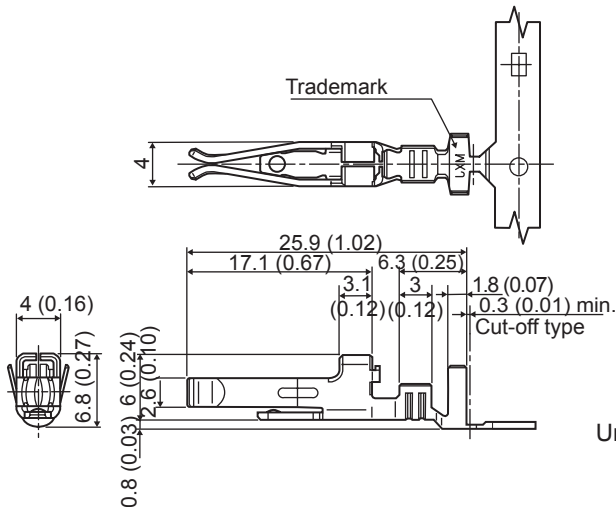

Units: mm (in)

4.3 CN1 Cables for I/O Signals

4.3.1 Standard Cables

(1) Cable Types

Cable Types	Length (L)
JZSP-VJI01-1	1 m (3.28ft)
JZSP-VJI01-2	2 m (6.56ft)
JZSP-VJI01-3	3 m (9.84ft)

(2) Dimensional Drawings

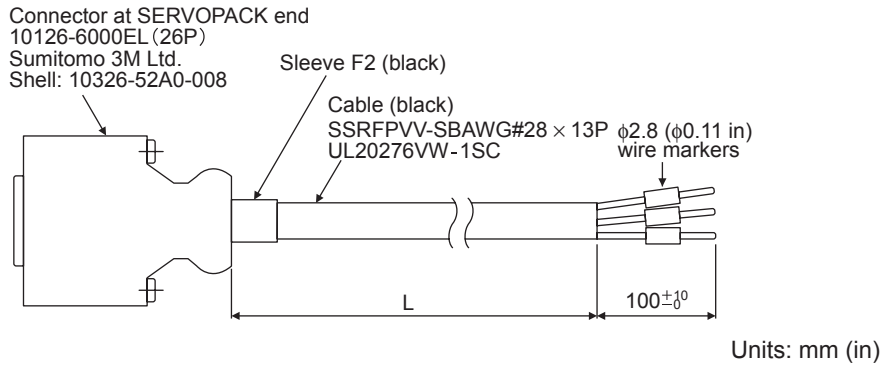

4.3.2 Connector Type and Cable Size

Use the following connector and wire when customers assemble the cable. The connector CN1 includes a set of case and a connector,

Connector Type	Connector Parts List			
	Case		Connector	
	Type	Qty	Type	Qty
JZSP-VJI9-1	10126-3000VE*	1 set	10326-52A0-008*	1

* Manufactured by Sumitomo 3M Ltd.

(1) Dimensional Drawings of Case

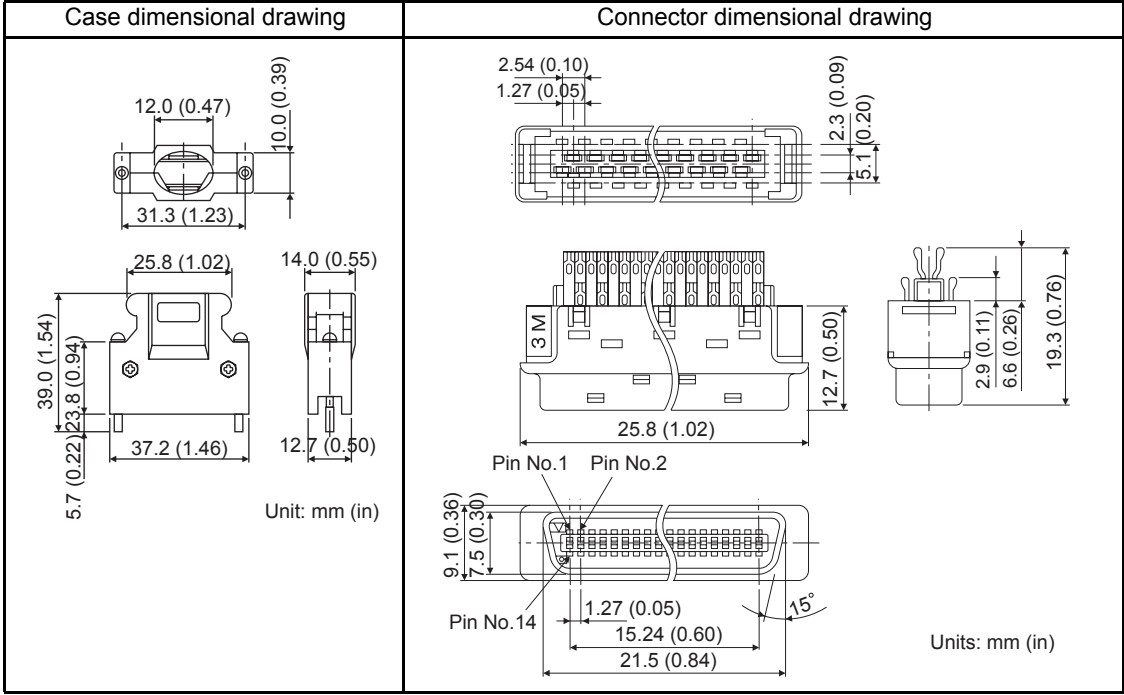

(2) Cable Size

Item	Specifications
Cable	Use twisted-pair or twisted-pair shielded wire.
Applicable wires	AWG24, 26, 28, 30
Cable Finished Diameter	φ16 mm (0.63 in) max.

4.4.1 Cables for Connecting Personal Computers

4.4 Peripheral Devices

4.4.1 Cables for Connecting Personal Computers

SGDS SynqNet does not support any connection to personal computers.

4.4.2 Digital Operator

(1) Model JUSP-OP05A with a 1m-connection Cable

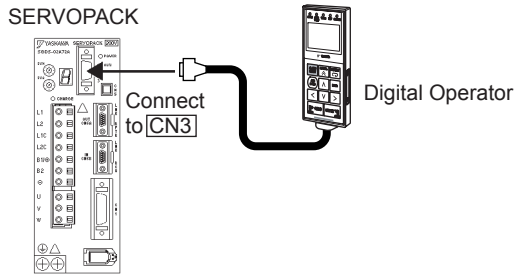

(2) Dimensional Drawings

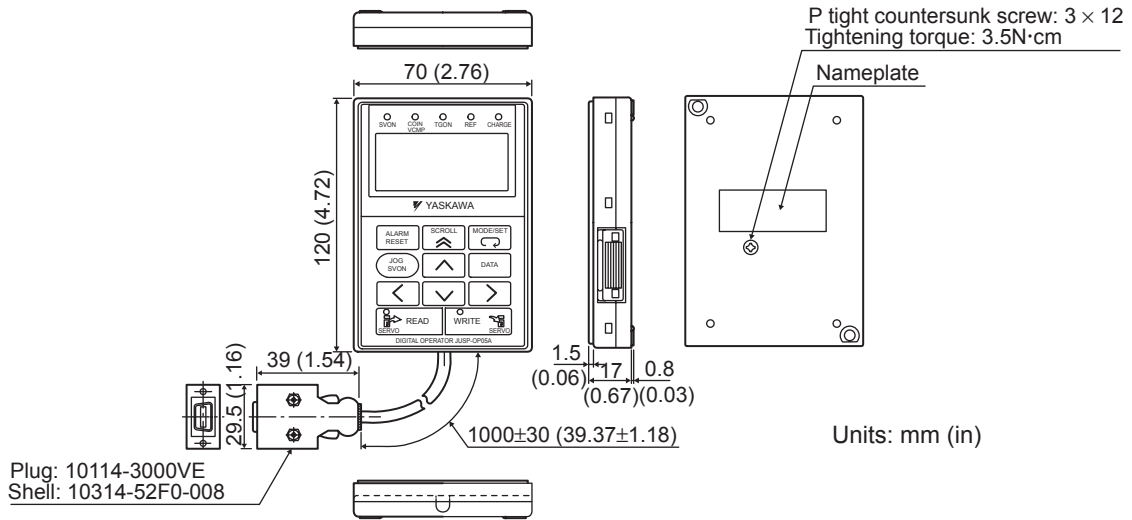

4.4.3 Cables for Analog Monitor

(1) Cable Type: JZSP-CA01

Connect the specified cables to CN5 connector for monitoring the analog monitor signals.

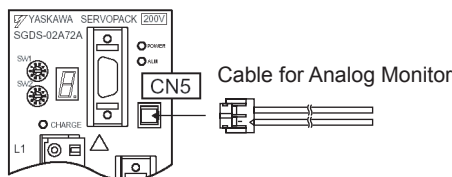

(2) Dimensional Drawings

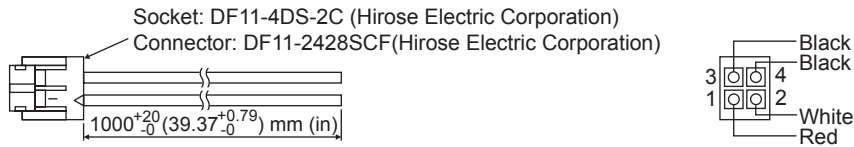

(3) Specifications

Cable Color	Signal Name	Explanation
White	Analog Monitor 1	Torque reference: 1 V / 100% rated torque
Red	Analog Monitor 2	Motor speed: 1 V / 1000 min ⁻¹
Black (2 cables)	GND (0 V)	Analog monitor GND: 0 V

4.4.4 Connector Terminal Block Converter Unit

(1) Model: JUSP-TA26P

The connection diagram for the connector terminal block converter unit is shown below.

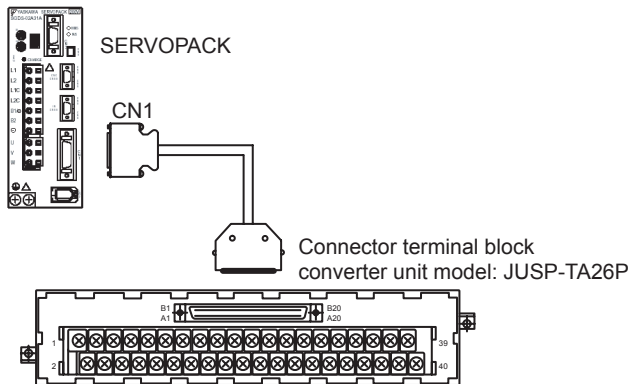

(2) Dimensional Drawings of Terminal Block

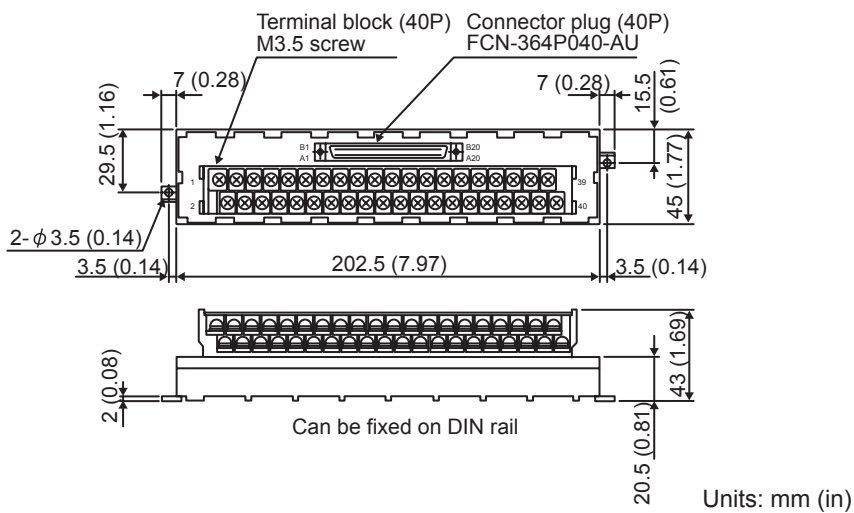

4.4.5 Brake Power Supply Unit

(3) Dimensional Drawings of Cable

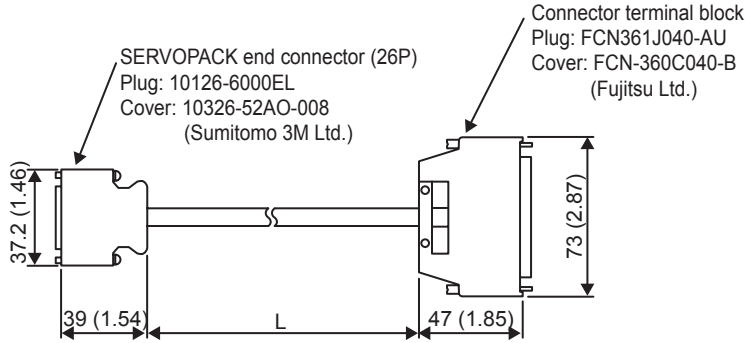

Model	Cable length (L)	Approx.mass
JUSP-TA26P	500 mm (19.69 in)	100g (0.22 lb)
JUSP-TA26P-1	1000 mm (39.37 in)	200g (0.44 lb)
JUSP-TA26P-2	2000 mm (78.74 in)	400g (0.88 lb)

4.4.5 Brake Power Supply Unit

(1) Model: LPSE-2H01, LPDE-1H01

Manufactured by Yaskawa Controls Co., Ltd.

- 200 V input: LPSE-2H01
- 100 V input: LPDE-1H01

(2) Specifications

- Rated output voltage: 90 VDC
- Maximum output current: DC 1.0 A
- Lead wire length: 500 mm (19.69 in) each

Maximum ambient temperature: 60°C (140 ° F)

- Lead wires: Color coded. Refer to the following table.

AC input		Brake end
100 V	200 V	
Blue/White	Yellow/White	Red/Blue

(3) Dimensional Drawings

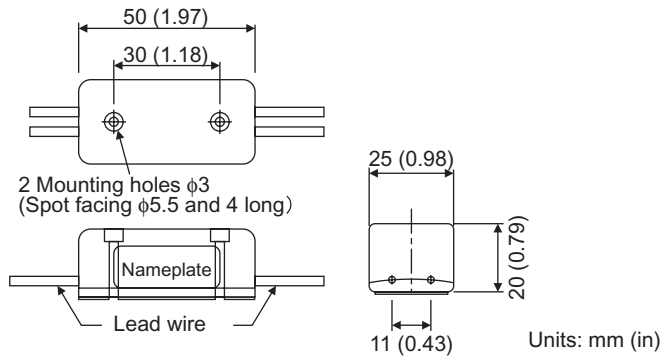

(4) Internal Circuits

Open or close the circuit for the brake's power supply so that is switched on the AC side.

When switching on the DC side, install a surge protector near the brake coil to prevent damage to the brake coil from voltage surges due to DC-side switching.

(a) Internal Circuit for 200 VAC Brake Power Supply Model: LPSE-2H01

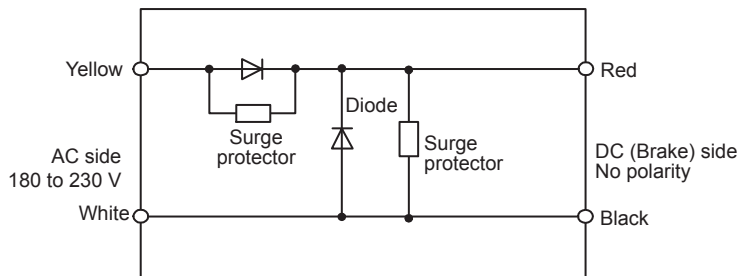

(b) Internal Circuit for 100 VAC Brake Power Supply Model: LPDE-1H01

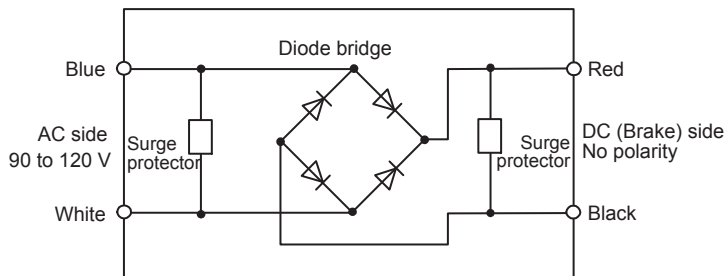

4

4.4.6 External Regenerative Resistor

When the regenerative energy exceeds the capacity of the SERVOPACK, install an external regenerative resistor. The regenerative resistor must be purchased separately by customers. Refer to the table below for selecting the regenerative resistor. Refer to 5.5 *Connecting Regenerative Resistors* for the connection.

(1) References for External Regenerative Resistor

Regenerative Resistor Model	Specifications	Manufacturer
RH120	70 W, 1 to 100 Ω	Iwaki Wireless Research Institute
RH150	90 W, 1 to 100 Ω	
RH220	120 W, 1 to 100 Ω	
RH300C	200 W, 1 to 10 kΩ	
RH500	300 W, 1 to 30 Ω	

(2) Model Designation

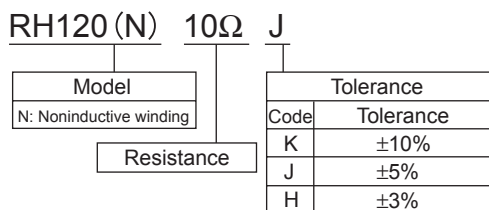

4.4.6 External Regenerative Resistor

(3) Specifications

Resistance Tolerance	K: $\pm 10\%$, J: $\pm 5\%$, H: $\pm 3\%$
Temperature Resistance Characteristics	± 400 PPM / $^{\circ}\text{C}$ (20 Ω max.) , ± 260 PPM / $^{\circ}\text{C}$ (20 Ω min.)
Withstand Voltage	2000 VAC/min. ΔR : $\pm (0.1\% + 0.05\Omega)$
Insulation Resistance	500 VDC, 20 M Ω minimum
Short-time Overload	When 10 times of rated power is applied for five seconds, ΔR : $\pm(2\% + 0.05\Omega)$
Life	1000 hours of repeating the operation ON for 90 minutes and OFF for 30 minutes, ΔR : $\pm(5\% + 0.05\Omega)$
Heat Resistance	Not ignite after having applied 10 times of rated electric power for one minute
Operating temperature	-25 $^{\circ}\text{C}$ to 150 $^{\circ}\text{C}$ (-13 $^{\circ}\text{F}$ to 302 $^{\circ}\text{F}$)

(4) Dimensional Drawings

<p style="text-align: center;">RH120/150/220</p> <p style="text-align: right;">Units: mm (in)</p> <p style="text-align: center;">Lead wire length L: 300 (11.81)</p> <table border="1" style="width: 100%; border-collapse: collapse; margin-top: 10px;"> <thead> <tr> <th>Model</th> <th>Rated Power</th> <th>Resistance</th> <th colspan="7">Dimensions</th> </tr> <tr> <th></th> <th></th> <th></th> <th>A</th> <th>B</th> <th>C</th> <th>D</th> <th>E</th> <th>F</th> <th>G</th> </tr> </thead> <tbody> <tr> <td>RH120</td> <td>70W</td> <td>1 Ω to 100 Ω</td> <td>182 (7.17)</td> <td>150 (5.91)</td> <td>172 (6.77)</td> <td>16 (0.63)</td> <td>42 (1.65)</td> <td>22 (0.87)</td> <td>20 (0.79)</td> </tr> <tr> <td>RH150</td> <td>90W</td> <td>1 Ω to 100 Ω</td> <td>212 (8.35)</td> <td>180 (7.09)</td> <td>202 (7.95)</td> <td>16 (0.63)</td> <td>44 (1.73)</td> <td>24 (0.94)</td> <td>30 (1.18)</td> </tr> <tr> <td>RH220</td> <td>120W</td> <td>1 Ω to 100 Ω</td> <td>230 (9.06)</td> <td>200 (7.87)</td> <td>220 (8.66)</td> <td>15 (0.59)</td> <td>60 (2.36)</td> <td>24 (0.94)</td> <td>20 (0.79)</td> </tr> </tbody> </table>	Model	Rated Power	Resistance	Dimensions										A	B	C	D	E	F	G	RH120	70W	1 Ω to 100 Ω	182 (7.17)	150 (5.91)	172 (6.77)	16 (0.63)	42 (1.65)	22 (0.87)	20 (0.79)	RH150	90W	1 Ω to 100 Ω	212 (8.35)	180 (7.09)	202 (7.95)	16 (0.63)	44 (1.73)	24 (0.94)	30 (1.18)	RH220	120W	1 Ω to 100 Ω	230 (9.06)	200 (7.87)	220 (8.66)	15 (0.59)	60 (2.36)	24 (0.94)	20 (0.79)	<p style="text-align: center;">RH220B</p> <p style="text-align: right;">Units: mm (in)</p> <p style="text-align: center;">Lead wire length L: 500 (19.69) Rated power: 120 W Resistance: 1 Ω to 100 Ω</p>
Model	Rated Power	Resistance	Dimensions																																																
			A	B	C	D	E	F	G																																										
RH120	70W	1 Ω to 100 Ω	182 (7.17)	150 (5.91)	172 (6.77)	16 (0.63)	42 (1.65)	22 (0.87)	20 (0.79)																																										
RH150	90W	1 Ω to 100 Ω	212 (8.35)	180 (7.09)	202 (7.95)	16 (0.63)	44 (1.73)	24 (0.94)	30 (1.18)																																										
RH220	120W	1 Ω to 100 Ω	230 (9.06)	200 (7.87)	220 (8.66)	15 (0.59)	60 (2.36)	24 (0.94)	20 (0.79)																																										
<p style="text-align: center;">RH300C</p> <p style="text-align: right;">Units: mm (in)</p> <p style="text-align: center;">Lead wire length L: 300 (11.81) Rated power: 200 W Resistance: 1 Ω to 10kΩ</p>	<p style="text-align: center;">RH500</p> <p style="text-align: right;">Units: mm (in)</p> <p style="text-align: center;">Lead wire length L: 450 (17.72) Rated power: 300 W Resistance: 1 Ω to 30 Ω</p>																																																		

4.4.7 Absolute Encoder Battery

After the power supply was turned OFF, a backup battery is required to write the position of absolute encoder. Install one of the absolute encoder batteries below.

(1) Battery Case

Model: JUSP-BA01

IMPORTANT

1. A battery is not mounted in the battery case. A battery must be purchased separately.
Battery Case Model: JZSP-BA01 (Refer to (2) *Battery Mounted in the Battery Case* on this page.)
2. Install the battery case where the ambient temperature is 0 to 55 °C (32 °F to 131 °F).

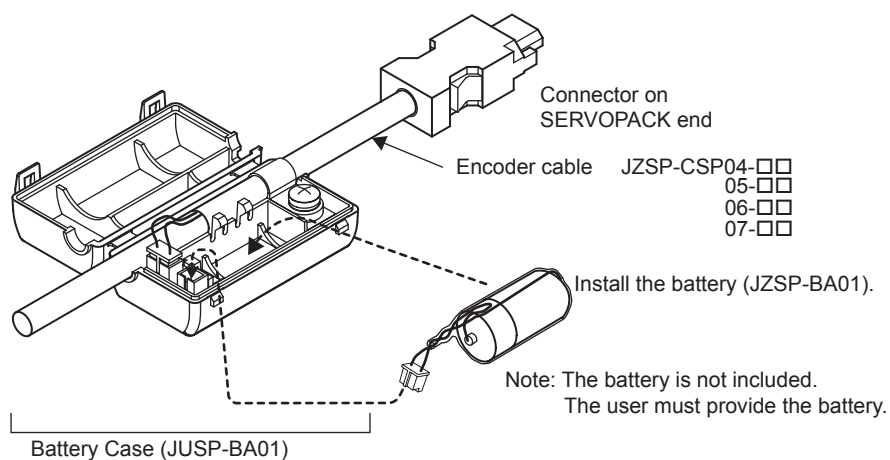

(2) Battery Mounted in the Battery Case

Model: JZSP-BA01 (lithium battery)

(Battery: ER3V battery made by Toshiba Battery Co., Ltd.)

3.6 V 1000 mAh

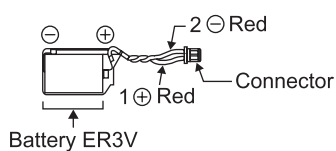

(3) Battery Installed on the Host Controller End

Model: ER6VC3N (lithium battery)

3.6 V 2000 mAh

Manufactured by Toshiba Battery Co., Ltd.

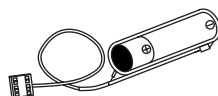

Location	Specification	Model Number	Manufacturer
Encoder cable	Lithium battery 3.6 V, 1000 mAh	ER3V	Toshiba Battery Co., Ltd.
Host controller	Lithium battery 3.6 V, 2000 mAh	ER6VC3N	Toshiba Battery Co., Ltd.

4.4.8 Molded-case Circuit Breaker (MCCB)

If selecting a molded-case circuit breaker, observe the following precautions.

IMPORTANT**■Ground Fault Detector**

- Select ground fault detectors for inverters.
- High-frequency current leaks from the servomotor armature because of switching operation inside the SERVOPACK.

(1) Maximum Input Current

- The instantaneous maximum output of SERVOPACK is approximately 3 times of the rated output for maximum for 3 seconds. Accordingly, select a molded-case circuit breaker whose breaking time is 5 seconds or more at 300% of SERVOPACK rated current.
The general-purpose low-speed acting molded-case circuit breakers are applicable.
- The power supply capacity per SERVOPACK when using a servomotor is described in *2.5.2 Molded-case Circuit Breaker and Fuse Capacity*. Select a molded-case circuit breaker with the capacity larger than the effective load current (when using more than multiple SERVOPACK) calculated from the total power supply capacity.
- The consumption of other controllers must be considered when selecting a molded-case circuit breaker.

(2) Inrush Current

- Refer to *2.5.2 Molded-case Circuit Breaker and Fuse Capacity* for SERVOPACK inrush current.
- The allowable inrush current for a low-speed acting molded-case circuit breaker is approximately 10 times of the rated current for 0.02 seconds.
- When turning ON multiple SERVOPACK simultaneously, select a molded-case circuit breaker with the allowable current for 20 ms larger than the total inrush current shown in *2.5.2 Molded-case Circuit Breaker and Fuse Capacity*.

4.4.9 Noise Filter

The recommended noise filter is manufactured by Schaffner Elektronik. Contact Yaskawa Controls Co., Ltd. Select one of the following noise filters according to SERVOPACK capacity. For more details on selecting the current capacity for a noise filter, refer to *2.5 Selecting Peripheral Devices*.

(1) Single-phase 100/200 V

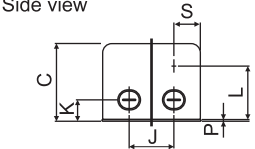
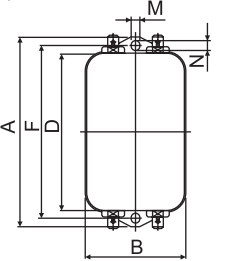
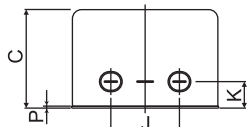
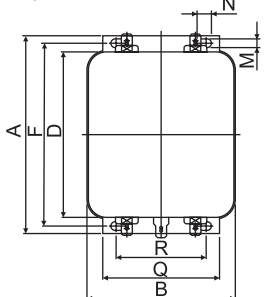
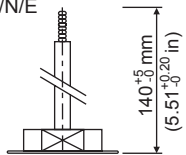
Model	FN2070-6/07	FN2070-10/07	FN2070-16/07
<p style="text-align: center;">Dimensional Drawings</p>	<p style="text-align: center;">Side view</p>  <p style="text-align: center;">Top view</p> 		<p style="text-align: center;">Side view</p>  <p style="text-align: center;">Top view</p> 
	<p style="text-align: center;">Contact Terminal</p> 		

4.4.9 Noise Filter

	Symbol	Dimensions in mm (in.)		
	External Dimensions	A	113.5 ± 1 (4.47±0.039)	156 ± 1 (6.14±0.039)
B		57.5 ± 1 (2.26±0.039)		85.5 ± 1 (3.37±0.039)
C		45.4 ± 1.2 (1.79±0.047)		57.6 ± 1 (2.27±0.039)
D		94 ± 1 (3.70±0.039)	130.5 ± 1 (5.14±0.039)	98.5 ± 1 (3.88±0.039)
F		103 ± 0.3 (4.06±0.012)	143 ± 0.3 (5.63±0.012)	109 ± 0.3 (4.29±0.012)
J		25 ± 0.2 (0.98±0.0079)		40 ± 0.2 (1.57±0.0079)
K		8.4 ± 0.5 (0.33±0.020)		8.6 ± 0.5 (0.33±0.020)
L		32.4 ± 0.5 (1.28±0.020)		-
M		4.4 ± 0.1 (0.17±0.004)	5.3 ± 0.1 (0.21±0.004)	4.4 ± 0.1 (0.17±0.004)
N		6 ± 0.1 (0.24±0.004)		7.4 ± 0.1 (0.29±0.004)
P		0.9 ± 0.1 (0.035±0.004)		1.2 ± 0.1 (0.047±0.004)
Q		-		66 ± 0.3 (2.60±0.012)
R		-		51 ± 0.2 (2.01±0.0079)
S		38 ± 0.5 (1.50±0.020)		-
Specifications		250 VAC, 6 A	250 VAC, 10 A	250 VAC, 16 A
Applicable SERVO- PACK SGDS-	Single- phase 100V	A5F	02F	04F
		01F		
	Single- phase 200V	A5A 01A 02A	04A	08A
Manufacturer		SCHAFFNER		

(2) Three-phase 200 V

Select one of the following noise filters according to SERVOPACK capacity. For more details on selecting current capacity for a noise filter, refer to 2.5 *Selecting Peripheral Devices*.

For connecting the noise filter, refer to 5.1.3 *Typical Main Circuit Wiring Examples*.

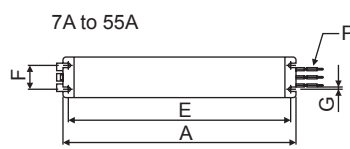
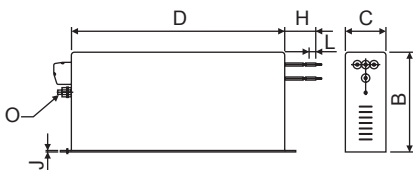
Model		FN258L-16/07	FN258L-30/07
Dimensional Drawings		Side view 7A to 55A 	Front/Side view 
External Dimensions	Symbol	Dimensions in mm (in.)	
	A	305 ± 1 (12.01 ± 0.039)	335 ± 1 (13.19 ± 0.039)
	B	142 ± 0.8 (5.59 ± 0.031)	150 ± 1 (5.91 ± 0.039)
	C	55 ± 0.6 (2.17 ± 0.024)	60 ± 0.6 (2.36 ± 0.024)
	D	275 ± 0.8 (10.83 ± 0.031)	305 ± 1 (12.01 ± 0.039)
	E	290 ± 0.5 (11.41 ± 0.020)	320 ± 0.5 (12.60 ± 0.020)
	F	30 ± 0.3 (1.18 ± 0.012)	35 ± 0.3 (1.38 ± 0.012)
	G	6.5 ± 0.2 (0.26 ± 0.008)	
	H	300 ± 10 (11.81 ± 0.394)	400 ± 10 (15.75 ± 0.394)
	J	1 ± 0.1 (0.04 ± 0.004)	
	L	9 ± 1 (0.35 ± 0.039)	
	O	M5	
	P	AWG14	AWG10
Specifications		AC480 V, 16 A	AC480 V, 30 A
Applicable SERVOPACK SGDS-	Three-phase 200V	10A, 15A, 20A	30A
Manufacturer		SCHAFNER	

4.4.10 Magnetic Contactor

4.4.10 Magnetic Contactor

(1) Model: HI-□J

The magnetic contactor is manufactured by Yaskawa Controls Co., Ltd. Contact your Yaskawa representative for details.

A magnetic contactor is required to make the AC power to SERVOPACK ON/OFF sequence externally. Be sure to attach a surge protector to the excitation coil of the magnetic contactor. Refer to 4.4.11 Surge Protector for details of the surge protector.

For selecting a magnetic contactor, refer to 2.5.3 Noise Filters.

(2) For Single-phase 100/200V and Three-phase 200 V SERVOPACKs

(a) Model: HI-11J and HI-14J

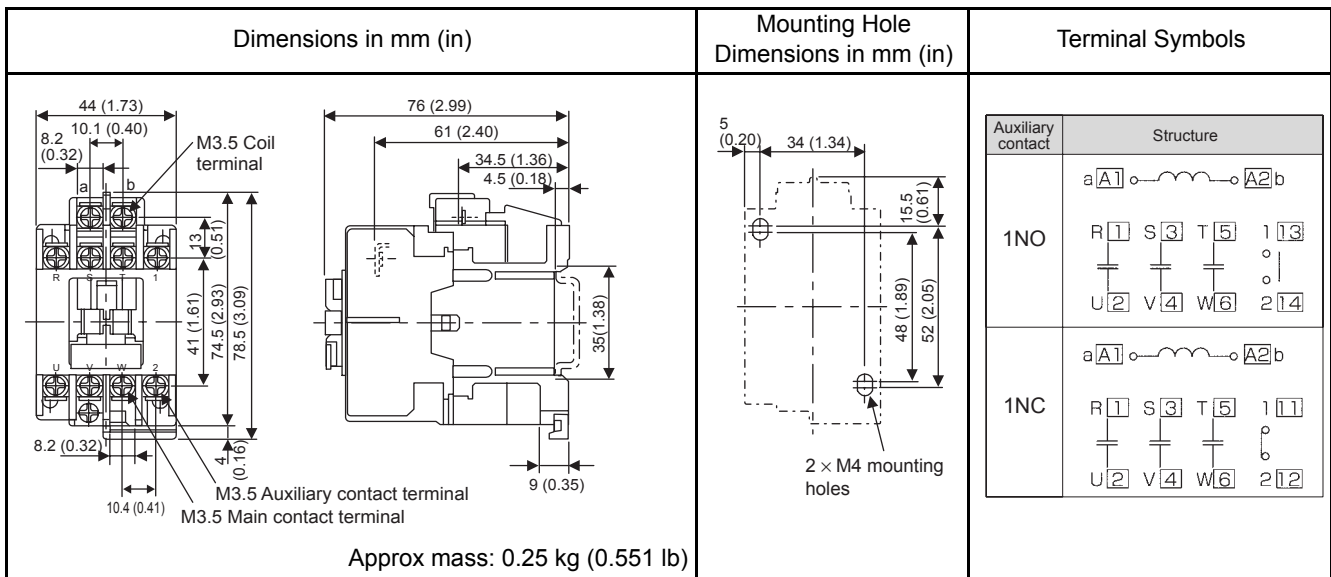

(b) Model: HI-15, HI-18J, and HI-20J

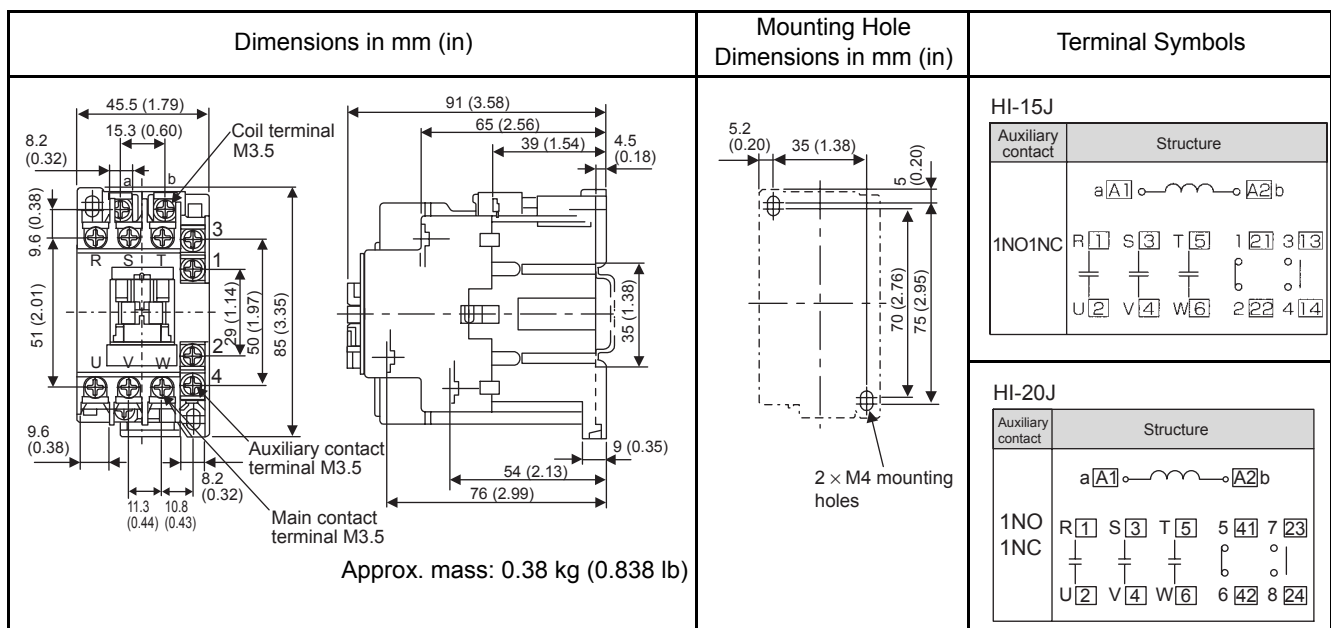

(c) Model: HI-25J and HI-35J

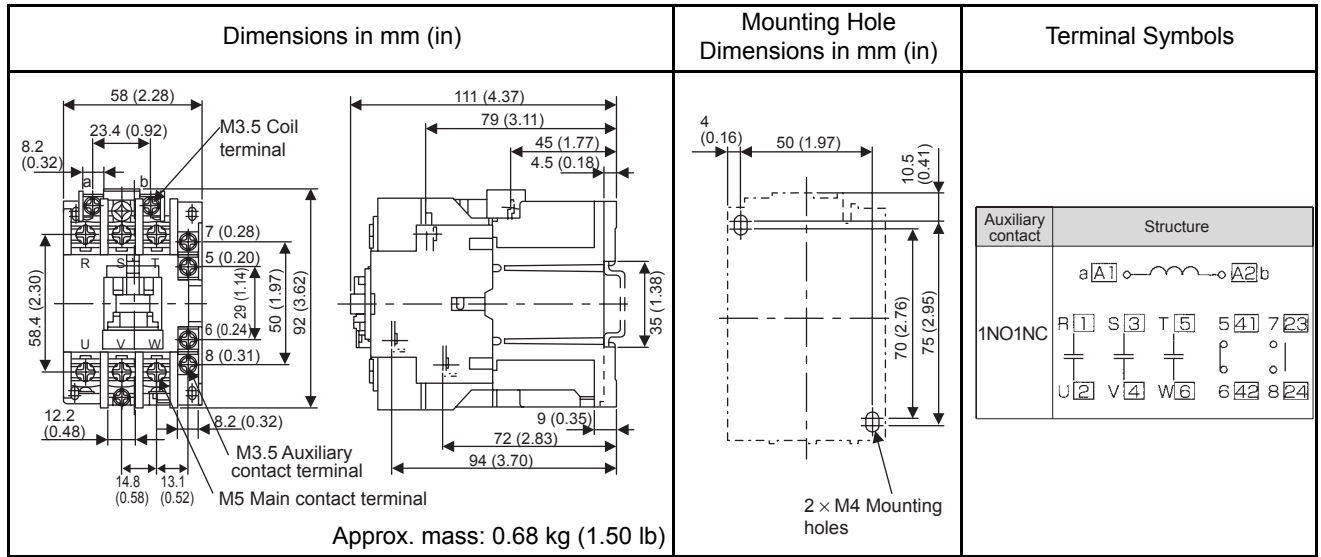

(d) Model: HI-50J and HI-65J

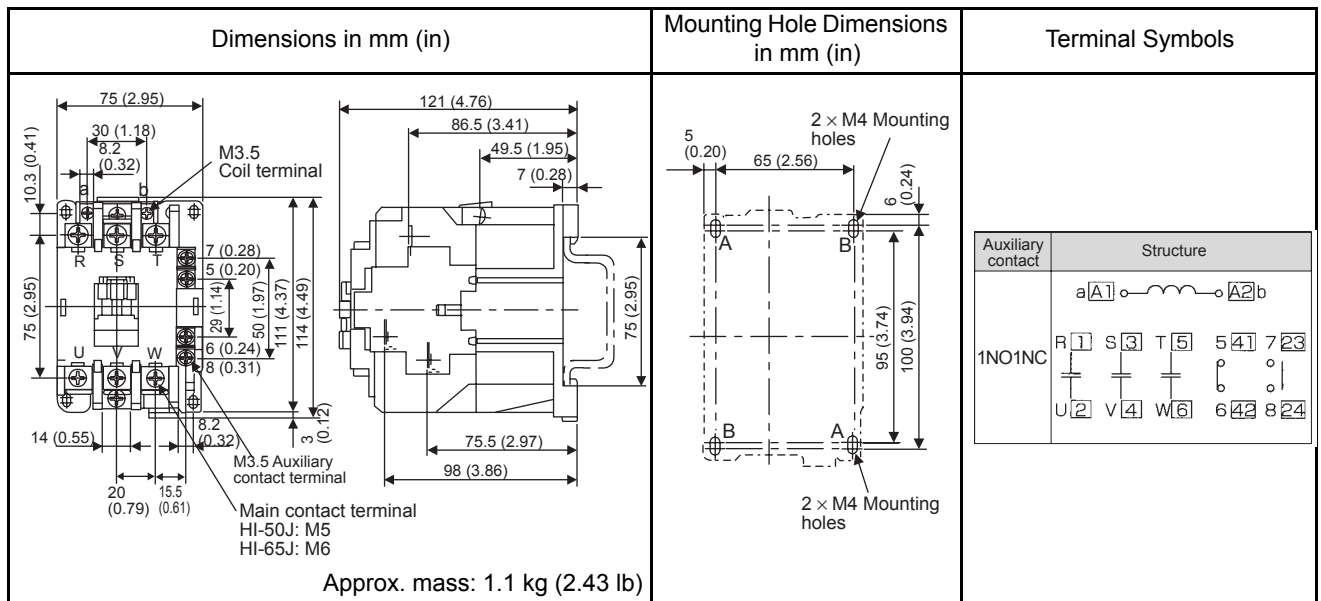

4.4.11 Surge Protector

4.4.11 Surge Protector

(1) Model: R·C·M-601BQZ-4 and R·C·M-601BUZ-4

Manufactured by Okaya Electric Industries Co., Ltd.

The surge protector absorbs surge voltage generated when the magnetic coil is OFF. This prevents faulty operation in or damage to electronic circuits near the magnetic contactors or switches.

Recommended surge protectors for HI-□J series magnetic contactors are listed below.

(2) Dimensional Drawings

(a) R·C·M-601BQZ-4

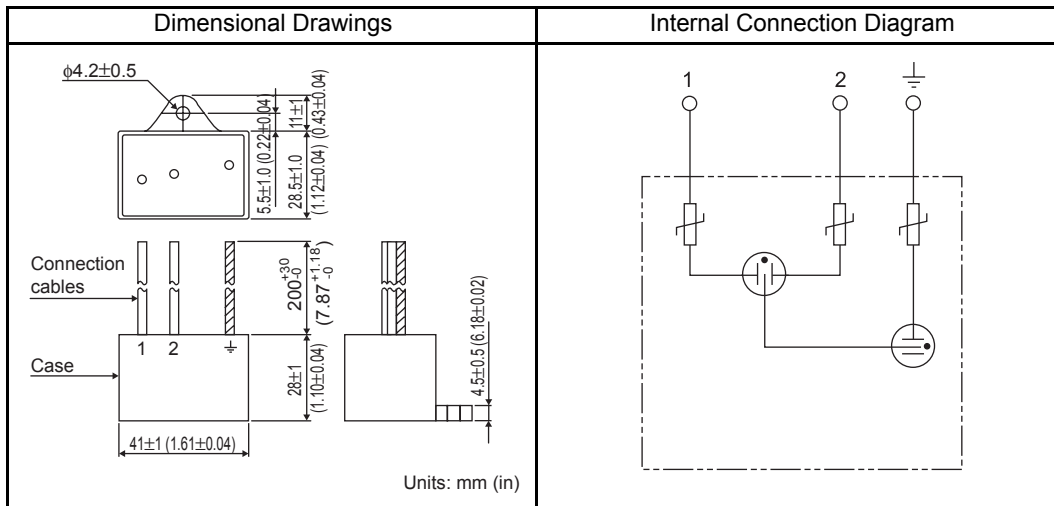

(b) R·C·M-601BUZ-4

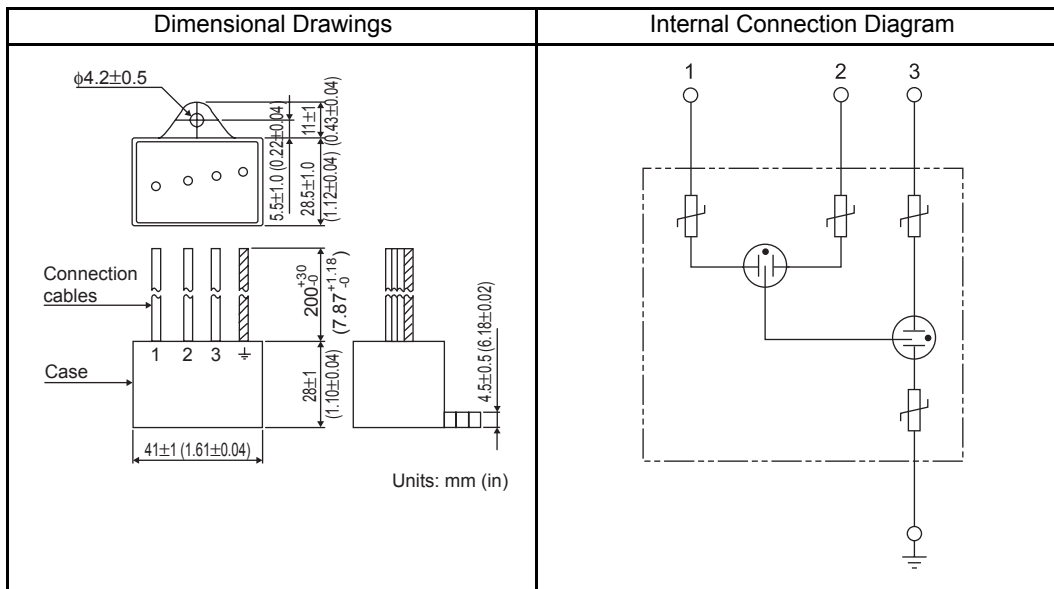

4.4.12 AC/DC Reactors for Harmonic Suppression

(1) Specifications

Manufactured by Yaskawa Controls Co., Ltd. Contact your Yaskawa representative for details.

If necessary for harmonic suppression, connect an AC reactor to the AC line for the single-phase input, a DC reactor between the SERVOPACK main circuit terminals $\ominus 1$ and $\ominus 2$ for the three-phase input. Select a reactor that matches the ratings of the SERVOPACK. For wiring, refer to *5.4.5 AC/DC Reactor for Harmonic Suppression*.

Applicable SERVOPACK Model SGDS-		AC/DC Reactor Model	Reactor Specifications	
			Inductance (mH)	Rated Current (A)
Single-phase, 100 V	A5F	X5053	20.0	2.0
	01F	X5053	20.0	2.0
	02F	X5054	5.0	3.0
	04F	X5056	2.0	5.0
Single-phase, 200 V	A5A	X5052	45.0	1.0
	01A	X5052	45.0	1.0
	02A	X5053	20.0	2.0
	04A	X5054	5.0	3.0
	08A	X5056	2.0	5.0
Three-phase, 200 V	10A	X5061	2.0	4.8
	15A	X5060	1.5	8.8
	20A			
	30A	X5059	1.0	14.0

(2) Dimensional Drawings

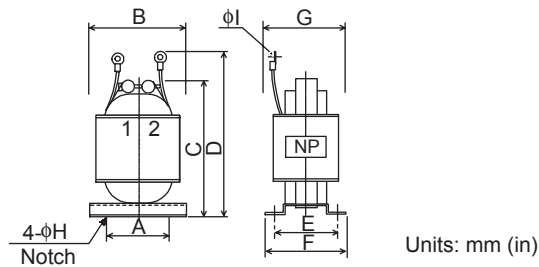

Reactor Model	Dimensions in mm (in)									Approx. Mass kg (lb)
	A	B	C	D	E	F	G	ϕH	ϕl	
X5052	35 (1.38)	52 (2.05)	80 (3.15)	95 (3.74)	30 (1.18)	40 (1.57)	45 (1.77)	4 (0.16)	4.3 (0.17)	0.4 (0.88)
X5053	35 (1.38)	52 (2.05)	90 (3.54)	105 (4.13)	35 (1.38)	45 (1.77)	50 (1.97)	4 (0.16)	4.3 (0.17)	0.6 (1.32)
X5054	35 (1.38)	52 (2.05)	80 (3.15)	95 (3.74)	30 (1.18)	40 (1.57)	45 (1.77)	4 (0.16)	4.5 (0.18)	0.4 (0.88)
X5056	35 (1.38)	52 (2.05)	80 (3.15)	95 (3.74)	30 (1.18)	40 (1.57)	45 (1.77)	4 (0.16)	4.3 (0.17)	0.4 (0.88)
X5059	50 (1.97)	74 (2.91)	125 (4.92)	140 (5.51)	35 (1.38)	45 (1.77)	60 (2.36)	5 (0.20)	5.3 (0.21)	1.1 (2.43)
X5060	40 (1.57)	59 (2.32)	105 (4.13)	125 (4.92)	45 (1.77)	60 (2.36)	65 (2.56)	4 (0.16)	4.3 (0.17)	1.0 (2.20)
X5061	35 (1.38)	52 (2.05)	80 (3.15)	95 (3.74)	35 (1.38)	45 (1.77)	50 (1.97)	4 (0.16)	4.3 (0.17)	0.5 (1.102)

5.1 Wiring Main Circuit	5-2
5.1.1 Names and Descriptions of Main Circuit Terminals	5-2
5.1.2 Wiring Main Circuit Terminal Block (Spring Type)	5-3
5.1.3 Typical Main Circuit Wiring Examples	5-4
5.2 Wiring Encoders	5-7
5.3 Examples of I/O Signal Connections	5-8
5.3.1 Connection Example	5-8
5.3.2 I/O Signal Connector (CN1) Terminal Layout	5-9
5.3.3 I/O Signal (CN1) Names and Functions	5-10
5.3.4 SynqNet Connectors (CN6A and CN6B)	5-11
5.4 Special Wiring	5-12
5.4.1 Wiring Precautions	5-12
5.4.2 Wiring for Noise Control	5-13
5.4.3 Using More Than One SERVOPACK	5-17
5.4.4 400-V Power Supply Voltage	5-18
5.4.5 AC/DC Reactor for Harmonic Suppression	5-19
5.5 Connecting Regenerative Resistors	5-20
5.5.1 Regenerative Power and Regenerative Resistance	5-20
5.5.2 Connecting External Regenerative Resistors	5-20
5.6 Flexible Cables	5-23

5.1 Wiring Main Circuit

This section describes typical examples of main circuit wiring, functions of main circuit terminals, and the power ON sequence.

 CAUTION	
<ul style="list-style-type: none"> Do not bundle or run power and signal lines together in the same duct. Keep power and signal lines separated by at least 30 cm (11.81 in). Use twisted-pair wires or multi-core shielded-pair wires for signal and encoder (PG) feedback lines. The maximum length is 3 m (118.11 inches) for reference input lines and is 20 m (787.40 in) for PG feedback lines. Do not touch the power terminals for five minutes after turning power OFF because high voltage may still remain in the SERVOPACK. Make sure the charge indicator is out first before starting an inspection. Avoid frequently turning the power ON and OFF. Do not turn the power ON or OFF more than once per minute. Since the SERVOPACK has a capacitor in the power supply, a high charging current flows for 0.2 seconds when the power is turned ON. Frequently turning power ON and OFF causes main power devices like capacitors and fuses to deteriorate, resulting in unexpected problems. 	

5.1.1 Names and Descriptions of Main Circuit Terminals

Terminal Symbol	Name	Description	
L1, L2 or L1, L2, L3	Main circuit input terminal	50 W to 400 W	Single-phase 100 to 115 V ^{+10%} , ^{-15%} (50/60 Hz)
		50 W to 400 W	Single-phase 200 to 230 V ^{+10%} , ^{-15%} (50/60 Hz)
		750W	Single-phase 200 to 230 V ^{+10%} , ^{-15%} (50/60 Hz) Note: Terminal L3 is not used. Do not connect.
		500 W to 3.0 kW	Three-phase 200 to 230 V ^{+10%} , ^{-15%} (50/60 Hz)
U, V, W	Servomotor connection terminals	Connects to the servomotor.	
L1C, L2C	Control power input terminal	50 W to 400 W	Single-phase 100 to 115 V ^{+10%} , ^{-15%} (50/60 Hz)
		50 W to 3.0 kW	Single-phase 200 to 230 V ^{+10%} , ^{-15%} (50/60 Hz)
	Ground terminals (x2)	Connects to the power supply ground terminals and servomotor ground terminal.	
B1/⊕, B2 or B1/⊕, B2, B3	External regenerative resistor terminal	50 W to 400 W	Normally not connected. Connect an external regenerative resistor (provided by customer) between B1/⊕ and B2 if the regenerative capacity is insufficient. Note: B3 terminal is not provided.
		750 W to 3.0 kW	Normally short B2 and B3 (for an internal regenerative resistor). Remove the wire between B2 and B3 and connect an external regenerative resistor between B1/⊕ and B2 if the capacity of the internal regenerative resistor is insufficient. Customers must provide an external regenerative resistor terminal.
⊖1, ⊖2	DC reactor connection terminal for power supply harmonic suppression	750 W to 3.0 kW	Normally short ⊖1-⊖2. If a countermeasure against power supply harmonic waves is needed, connect a DC reactor between ⊖1-⊖2

(cont'd)

Terminal Symbol	Name	Description	
B1/⊕	Main circuit plus terminal	50 W to 3.0 kW	Use when DC power supply input is used. Refer to 5.1.3 (4) <i>DC Power Supply Input for SERVOPACK.</i>
⊖	Main circuit minus terminal	50 W to 400 W	

5.1.2 Wiring Main Circuit Terminal Block (Spring Type)

⚠ CAUTION

- Observe the following precautions when wiring main circuit terminal blocks.
 - Remove the terminal block from the SERVOPACK prior to wiring.
 - Insert only one wire per terminal on the terminal block.
 - Make sure that the core wire is not electrically shorted to adjacent core wires.

(1) Wire Size

Wire can be used simply by stripping back the outer coating. The following are applicable wire sizes.

- Single wire: $\phi 0.5$ (0.02) to $\phi 1.6$ (0.06) mm (inches)
- Braided wire: AWG28 to AWG12

(2) Connection Procedure

1. Strip the end of the wire.

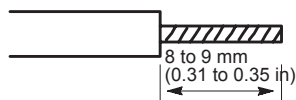

2. Open the wire terminal on the terminal block housing (plug) with the tool using the procedure shown in Fig. A and B.

- Press the lever and insert the wire into the wire terminal on the hook end of the tool as shown in Fig. A.
- Use a standard flat-blade screwdriver (blade width of 3.0 to 3.5 mm (0.12 to 0.14 in)) or type 54932-0000 manufactured by Molex Japan Co., Ltd. Put the blade into the slot, as shown in Fig. B, and press down firmly to open the wire terminal.

Either the procedure shown in Fig. A or B can be used to open the wire insert opening.

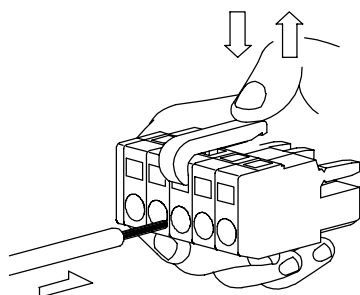

Fig. A

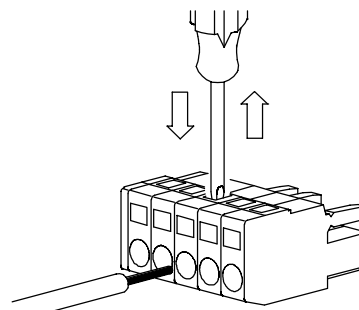
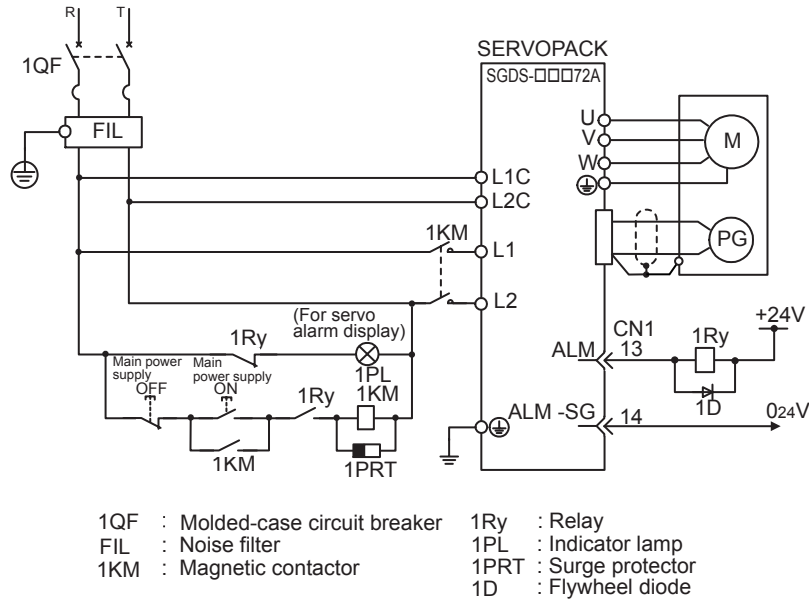

Fig. B

3. Insert the wire core into the opening and then close the opening by releasing the lever or removing the screwdriver.

5.1.3 Typical Main Circuit Wiring Examples

(1) Single-phase 100/200 V



(2) Three-phase 200 V

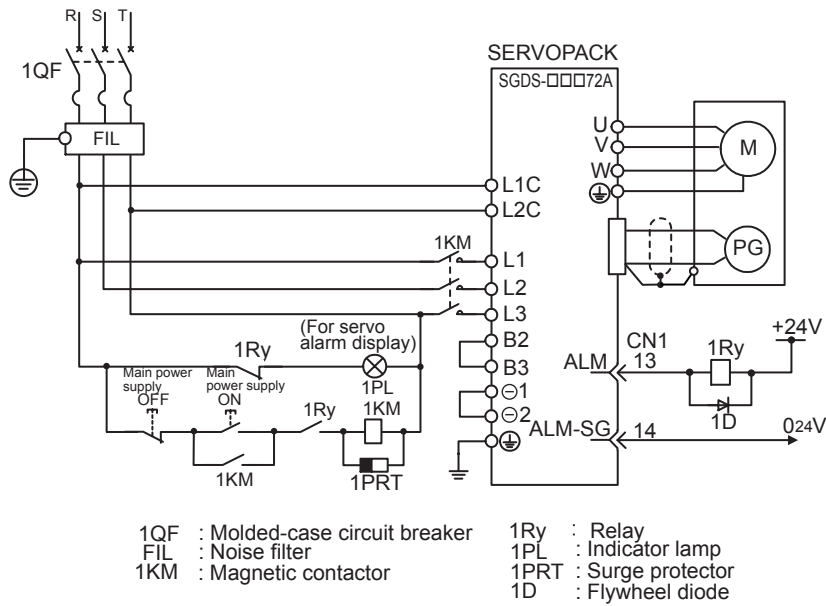

(3) 750 W, Single-phase 200V

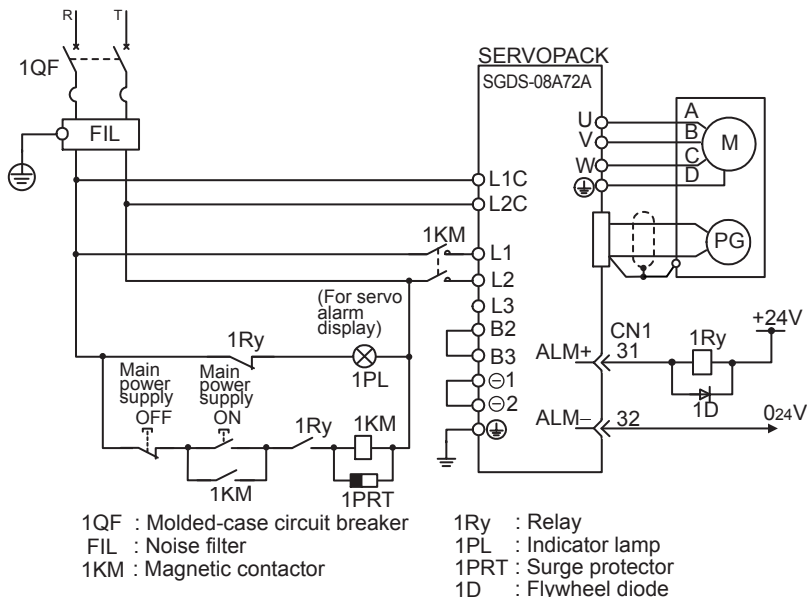

Note: Terminal L3 is not used for the single-phase 200 V, 750W SERVOPACKs. Do not connect.

IMPORTANT

■ Designing a Power ON Sequence

Note the following points when designing the power ON sequence.

- Design the power ON sequence so that main circuit power is turned OFF when a servo alarm signal is output. (See the circuit figure above.)
- The ALM signal is output for approximately two seconds when the power is turned ON. Take this into consideration when designing the power ON sequence. The ALM signal actuates the alarm detection relay 1Ry to stop main circuit power supply to the SERVOPACK.

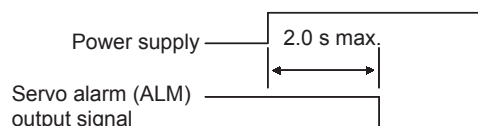

- Select the power supply specifications for the parts in accordance with the input power supply.

(4) DC Power Supply Input for SERVOPACK

 **CAUTION**

- Do not use a DC power supply for the 100V SERVOPACK SGDS-□□F□□□.
 - A DC power will destroy the SERVOPACK and may cause a fatal accident or fire. Do not change the factory setting for Pn001 = n.□0□□ (DC power supply input not supported).
 - The AC and DC power can be used with the 200V SERVOPACK SGDS-□□A□□□.
 - Before using DC power supply, Pn001 = n.□1□□ (DC power supply supported) must be selected. Failure to do so will cause the internal element of the SERVOPACK to burn out, and fire and damage to the devices may result.
- Check the parameter setting before using a DC power supply.

When using a DC power supply for the SERVOPACK SGDS-□□A□□□, use the terminals listed in the following table and make sure that the parameter Pn001.2 is set to “1.” Also, observe the precautions given in IMPORTANT.

IMPORTANT

1. The servomotor returns the regenerated energy to the power supply. The SERVOPACK that can use a DC power supply is not capable of processing the regenerated energy. Provide measures to process the regenerated energy on the power supply.
2. With a SERVOPACK that is using DC power, a certain amount of time is required to discharge all remaining electricity after the main power supply is turned OFF. Note that high-voltage electricity remains in the SERVOPACK after the power supply is turned ON.

(a) DC Power Supply Input Terminals for the Main and Control Circuits

Terminal Symbols	Name	Description
B1/⊕	Main circuit positive polarity terminal	270 VDC to 320 VDC
⊖ or ⊖2	Main circuit negative polarity terminal	0V
L1C, L2C	Control power supply input terminal	270 VDC to 320 VDC (No polarity)

(b) Parameter Setting

Parameter	Meaning
Pn001	n.□0□□ DC power input not supported (AC power input to the L1, L2 or L3 terminals)
	n.□1□□ DC power input supported (DC power input to B1/⊕ and ⊖, or B1/⊕ and ⊖2)
• Turn the power OFF and turn it ON again to validate the setting.	

5.2 Wiring Encoders

The connection cable between encoders and the SERVOPACK, and the pin numbers for wiring depend on the servomotor model.

- CN2 Encoder Connector Terminal Layout

1	PG5V	PG power supply +5 V	2	PG 0 V	PG power supply 0 V
3	BAT (+)	Battery (+) (For an absolute encoder)	4	BAT (-)	Battery (-) (For an absolute encoder)
5	PS	PG serial signal input	6	/PS	PG serial signal input
SHELL	Shield	-	-	-	-

5.3 Examples of I/O Signal Connections

5.3.1 Connection Example

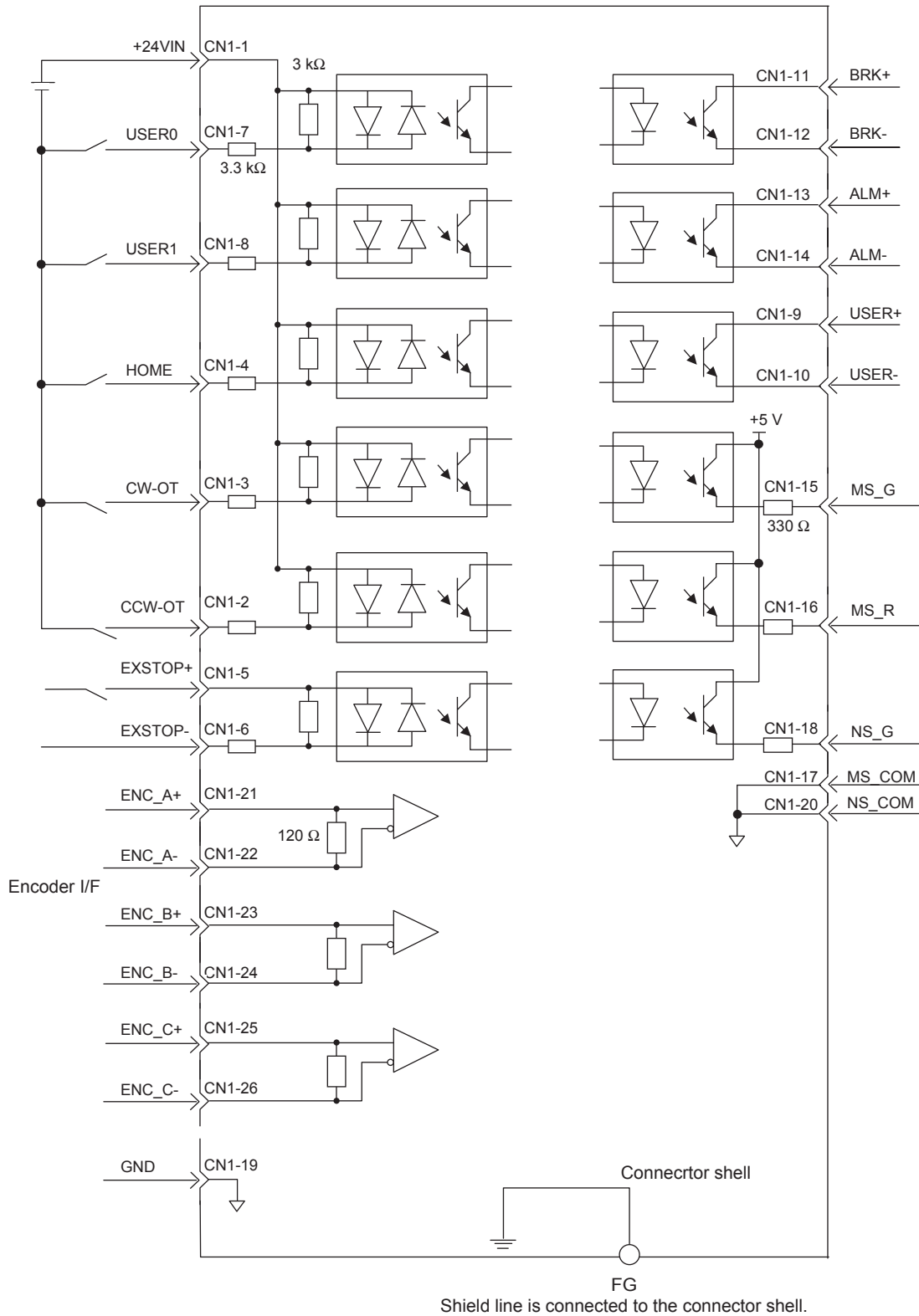

5.3.2 I/O Signal Connector (CN1) Terminal Layout

2	CCW-OT	CCW run prohibit signal	1	+24VIN	External input power supply	14	ALM-	Servo alarm signal output -
4	HOME	Home signal input	3	CW-OT	CW run prohibit signal	15	MS_G	Module status output (green)
6	EXSTOP-	External stop signal input -	5	EXSTOP+	External stop signal input +	16	MS_R	Module status output (red)
8	USER1	User input signal 1	7	USER0	User input signal 0	17	MS-COM	Module status common
10	USER	User signal output -	9	USER+	User signal output +	18	NS_G	Network status output (green)
12	BRK-	Brake signal output -	11	BRK+	Brake signal output +	19	GND	Ground
			13	ALM+	Servo alarm signal output +	20	NS_COM	Network status common
						21	ENC_A+	External encoder A
						22	ENC_A-	External encoder A
						23	ENC_B+	External encoder B
						24	ENC_B-	External encoder B
						25	ENC_C+	External encoder C
						26	ENC_C-	External encoder C

- Note: 1. Do not use unused terminals for relays.
 2. Connect the shield of the I/O signal cable to the connector shell.
 Connect to the FG (frame ground) at the SERVOPACK-end connector.

5.3.3 I/O Signal (CN1) Names and Functions

(1) Input Signals

Signal Name	Pin No.	Function	
+24VIN	1	Control power supply input for sequence signals: Users must provide the +24-V power supply. Allowable voltage fluctuation range: 11 to 25 V	
CCW-OT CW-OT	2 3	CCW run prohibit CW run prohibit	Overtravel prohibit (used in position mode only) : Stops the motor when the axis exceeds the movable range.
HOME	4	Home signal (used in position mode only) : Reports the home position of machine to the SERVOPACK.	
EXSTOP+ EXSTOP-	5 6	External stop input : Stops the servomotor immediately, and the servo is turned OFF.	
USER0 USER1	7 8	User input signal	
ENC_A+ ENC_A- ENC_B+ ENC_B-	21 22 23 24	External encoder input	
ENC_C+ ENC_C-	25 26	External encoder input for C channel	

(2) Output Signals

Signal Name	Pin No.	Function	
USER+ USER-	9 10	User output signal	
BRK+ BRK-	11 12	Brake output : Use when a motor with a brake is used.	
ALM+ ALM-	13 14	Servo alarm : Turns OFF when an error is detected.	
MS_G	15 (17)	Module status output (green)	
MS_R	16 (17)	Module status output (red) : Active use when there is a servo alarm.	
NS_G	18 (20)	Network status output (green) : Active use when communication is established with SynqNet.	

Note: Pin numbers in parentheses () indicate signal grounds.

5.3.4 SynqNet Connectors (CN6A and CN6B)

The following table show the terminal layout for the SynqNet connector and its specifications.

(1) Connector Specification

Name		Model	Manufacturer
Unit-end	Commercial Ulti-mate Micro-D connector	83611-9006	Molex
Cable-end	Commercial Ulti-mate Micro-D cable receptacle	83421-9014	Molex

(2) Connector Pin Arrangement

The following tables show the arrangement of the connector pin.

Pin	Terminal name	I/O	Pin	Terminal name	I/O
1	CONN_RD1+	Input	6	CONN_RD1-	Input
2	RD1_COMM	–	7	RD1_COMM	–
3	EARTHGND_OUT	–	8	TD1_COMM	–
4	TD1_COMM	–	9	CONN_TD1-	Output
5	CONN_TD1+	Output			



Pin	Terminal name	I/O	Pin	Terminal name	I/O
1	CONN_TD0+	Output	6	CONN_TD0-	Output
2	TD0_COMM	–	7	TD0_COMM	–
3	EARTHGND_IN	–	8	RD0_COMM	–
4	RD0_COMM	–	9	CONN_TD0-	Input
5	CONN_RD0+	Input			

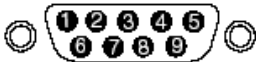

5.4 Special Wiring

5.4.1 Wiring Precautions

To ensure safe and stable operation, always observe the following wiring precautions.

IMPORTANT

1. For wiring for reference inputs and encoders, use the specified cables. Refer to *4 Specifications and Dimensional Drawings of Cables and Peripheral Devices* for details.
Use cables that are as short as possible.
 2. For the ground wire, use as thick a cable as possible (2.0 mm² (0.079 in²) or thicker).
 - At least class-3 ground (100 Ω max.) is recommended.
 - Ground to one point only.
 - If the motor is insulated from the machine, ground the motor directly.
 3. Do not bend or apply tension to cables.
The conductor of a signal cable is very thin (0.2 to 0.3 mm (0.0079 to 0.012 in)), so handle the cables carefully.
 4. Use a noise filter to prevent noise interference.
(For details, refer to *5.4.2 Wiring for Noise Control*.)
 - If the equipment is to be used near private houses or may receive noise interference, install a noise filter on the input side of the power supply line.
 - Since the SGDS SERVOPACK is designed as an industrial device, it provides no mechanism to prevent noise interference.
 5. To prevent malfunction due to noise, take the following actions:
 - Position the input reference device and noise filter as close to the SERVOPACK as possible.
 - Always install a surge protector circuit in the relay, solenoid and electromagnetic contactor coils.
 - The distance between a power line (such as the power supply line or motor cable) and a signal line must be at least 30 cm (11.81 in). Do not put the power and signal lines in the same duct or bundle them together.
 - Do not share the power circuit with an electric welder or electrical discharge machine. When the SERVOPACK is placed near a high-frequency generator, install a noise filter on the input side of the power supply line.
 6. Use a molded-case circuit breaker (QF) or fuse to protect the power supply line from high voltage.
 - The SGDS SERVOPACK connects directly to a commercial without a transformer, so always use a QF or fuse to protect the SERVOPACK from accidental high voltage.
 7. The SGDS SERVOPACKs do not have built-in ground protection circuits. To configure a safer system, install an earth leakage breaker for protection against overloads and short-circuiting, or install an earth leakage breaker combined with a wiring circuit breaker for ground protection.
-

5.4.2 Wiring for Noise Control

(1) Wiring Example

The SGDS SERVOPACK uses high-speed switching elements in the main circuit. It may receive “switching noise” from these high-speed switching elements if wiring or grounding around the SERVOPACK is not appropriate. To prevent this, always wire and ground the SERVOPACK correctly.

The SGDS SERVOPACK has a built-in microprocessor (CPU), so protect it from external noise as much as possible by installing a noise filter in the appropriate place.

The following is an example of wiring for noise control.

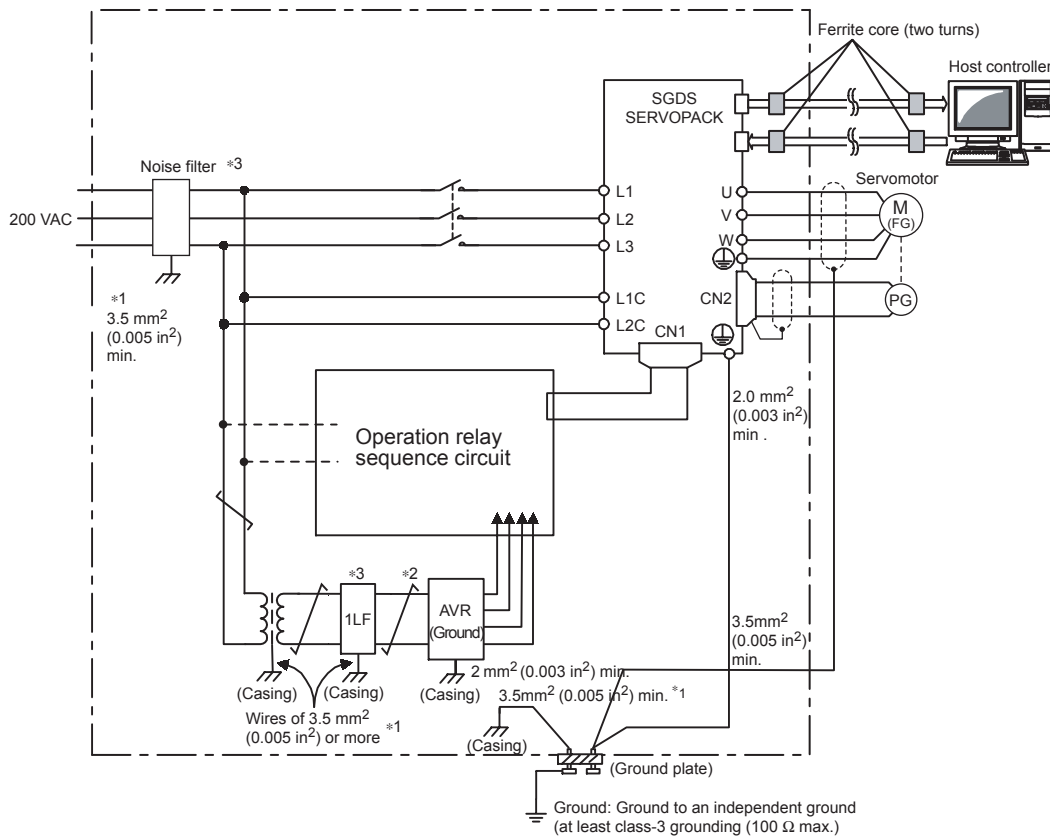

*1 For ground wires connected to the casing, use a thick wire with a thickness of at least 3.5 mm² (0.005 in²) (preferably, plain stitch cooper wire)

*2  should be twisted-pair wires.

*3 When using a noise filter, follow the precautions in (3) *Using Noise Filter*.

(2) Grounding

(a) Motor Frame

Always connect servomotor frame terminal FG to the SERVOPACK ground terminal \ominus . Also be sure to ground the ground terminal \oplus .

If the servomotor is grounded via the machine, a switching noise current will flow from the SERVOPACK power unit through motor stray capacitance. The above grounding is required to prevent the adverse effects of switching noise.

(b) SynqNet Communication Cable

Make sure to keep the box or power line separate from the SynqNet communication cable because the cable is easily influenced by noise.

If noise is a problem, coil the communication cable two turns around the ferrite cores on the SERVOPACK end and the controller end. Refer to the following diagram.

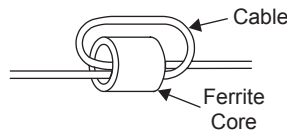

Recommended core: ZCAT2436-1330 (TDK)

(c) Noise on the Reference Input Line

If the reference input line receives noise, ground the 0 V line (SG) of the reference input line. If the main circuit wiring for the motor is accommodated in a metal conduit, ground the conduit and its junction box. For all grounding, ground at one point only.

All grounds must be made to only one point in the system.

(3) Using Noise Filters

Use an inhibit type noise filter to prevent noise from the power supply line. The following table lists recommended noise filters for each SERVOPACK model.

Install a noise filter on the power supply line for peripheral equipment as necessary.

Noise Filters

Voltage	SERVOPACK Model		Recommended Noise Filters		
	Capacity (kW)	SGDS-	Model	Specification	Manufacturer
Single-phase 100 V	0.05	A5F	FN2070-6/07	Single-phase 250 VAC, 6 A	Schaffner Elektronik
	0.10	01F			
	0.20	02F			
	0.40	04F			
Single-phase 200 V	0.05	A5A	FN2070-6/07	Single-phase 250 VAC, 6 A	
	0.10	01A			
	0.20	02A			
	0.40	04A			
	0.75	08A			
Three-phase 200 V	1.0	10A	FN258L-16/07	Three-phase 480 VAC, 16 A	
	1.5	15A			
	2.0	20A			
	3.0	30A			FN258L-30/07

Always observe the following installation and wiring instructions. Incorrect use of a noise filter halves its benefits.

IMPORTANT

- Do not put the input and output lines in the same duct or bundle them together.

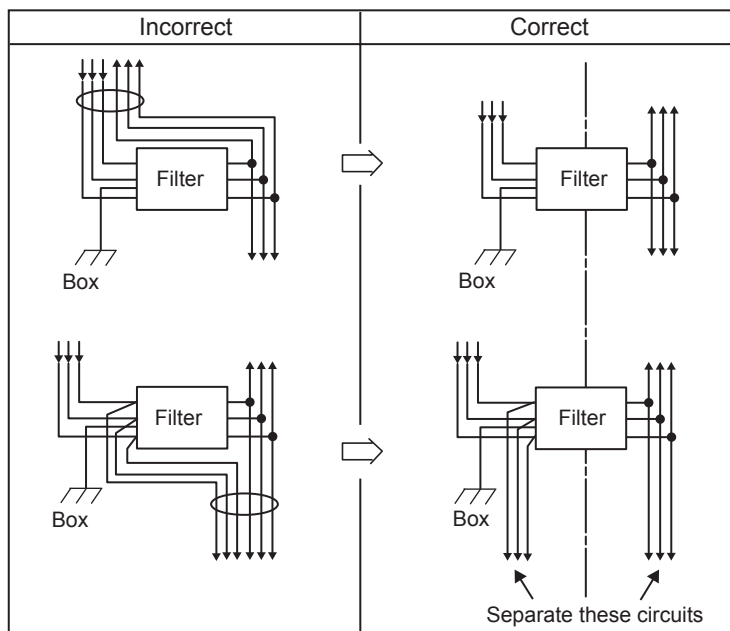

- Separate the noise filter ground wire from the output lines.
Do not accommodate the noise filter ground wire, output lines and other signal lines in the same duct or bundle them together.

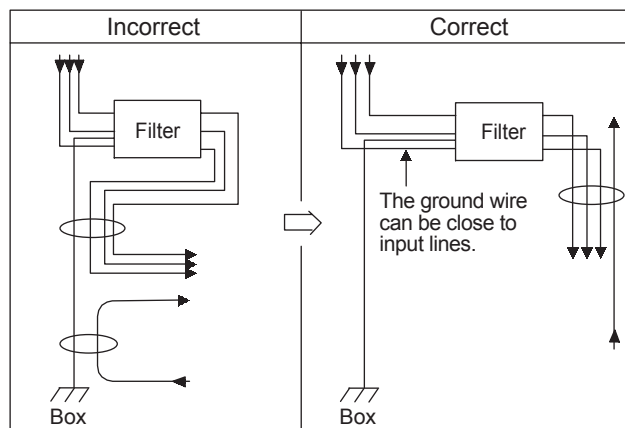

- Connect the noise filter ground wire directly to the ground plate.
Do not connect the noise filter ground wire to other ground wires.

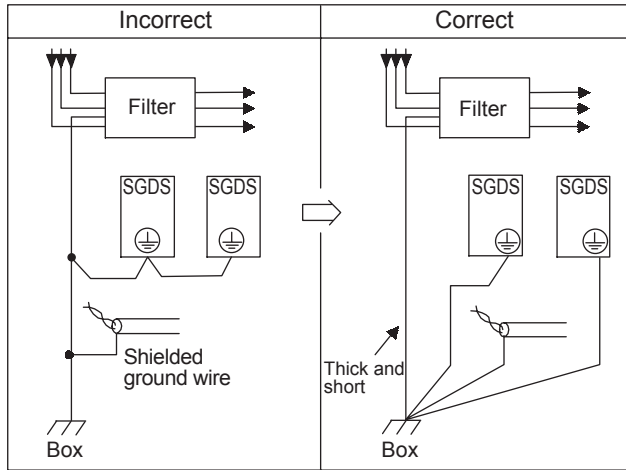

- When grounding a noise filter inside a unit.
If a noise filter is located inside a unit, connect the noise filter ground wire and the ground wires from other devices inside the unit to the ground plate for the unit first, then ground these wires.

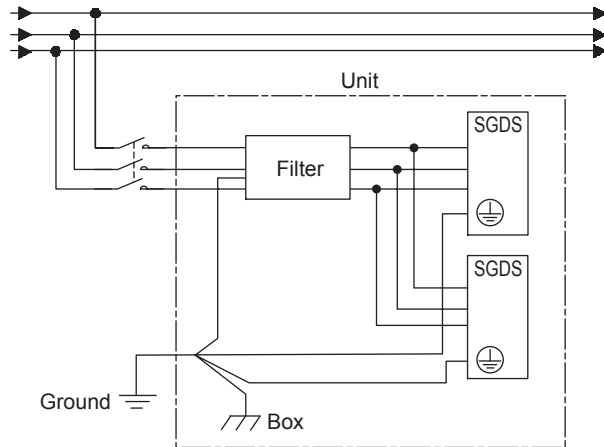

5.4.3 Using More Than One SERVOPACK

The following diagram is an example of the wiring when more than one SERVOPACK is used.

Connect the alarm output (ALM) terminals for the three SERVOPACKs in series to enable alarm detection relay 1RY to operate.

When the alarm occurs, the ALM output signal transistor is turned OFF.

Multiple servos can share a single molded-case circuit breaker (QF) or noise filter. Always select a QF or noise filter that has enough capacity for the total power capacity (load conditions) of those servos. For details, refer to *2.5.2 Molded-case Circuit Breaker and Fuse Capacity*.

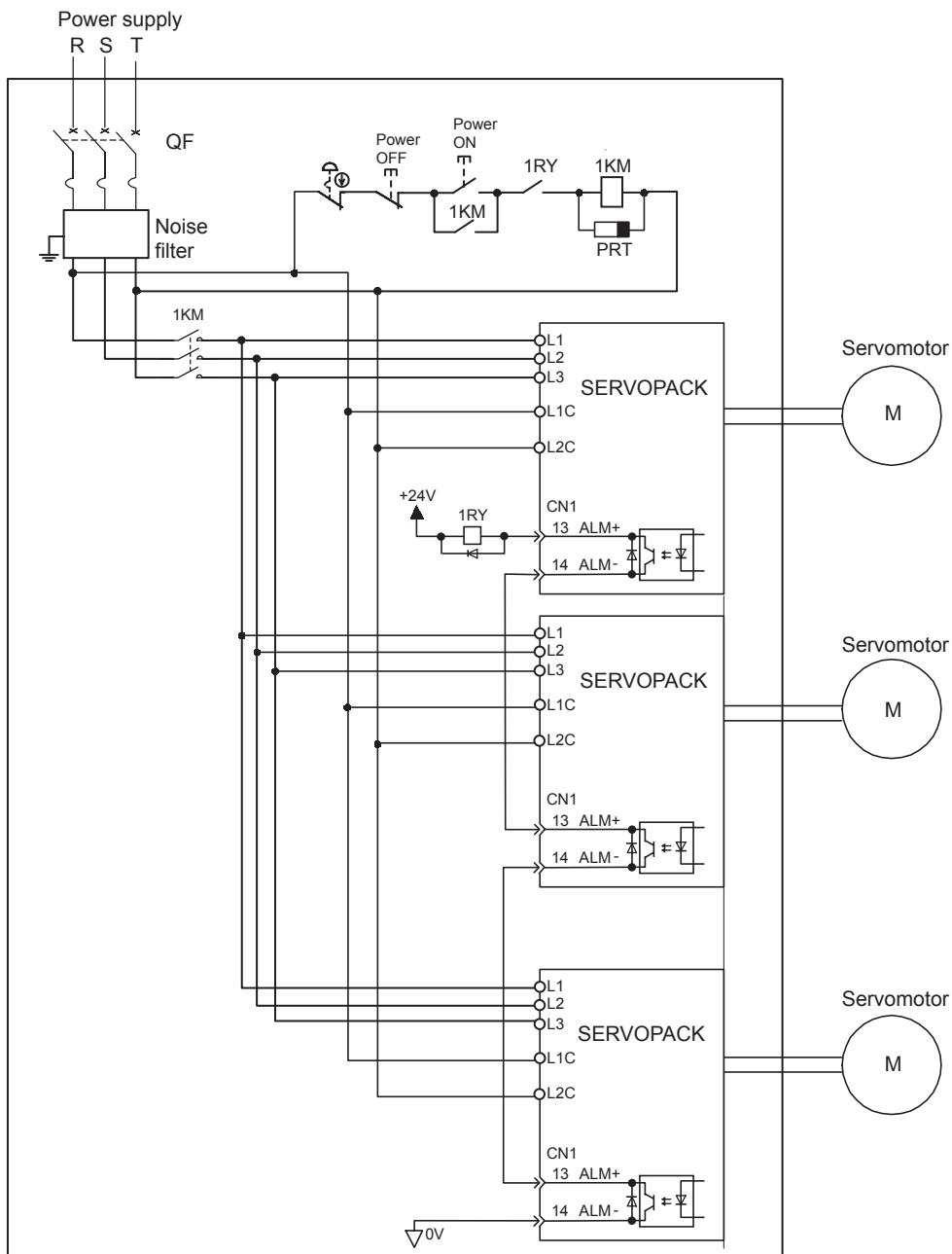

Note: Wire the system so that the power supply's phase-S is the ground.

5.4.4 400-V Power Supply Voltage

 CAUTION

- Do not connect the SERVOPACK for 100 V and 200 V directly to a voltage of 400 V. The SERVOPACK will be destroyed.
- Control the AC power supply ON and OFF sequence at the primary side of the voltage conversion transformer. Voltage conversion transformer inductance will cause a surge voltage if the power is turned ON and OFF at the secondary, damaging the SERVOPACK.

When using SERVOPACK with the three-phase 400-VAC class (380 V to 480 V), prepare the following voltage conversion transfers (single-phase or three-phase).

Primary Voltage		Secondary Voltage
380 to 480 VAC	→	200 VAC
380 to 480 VAC	→	100 VAC

When selecting a voltage conversion transfer, refer to the capacities shown in the following table.

Voltage	SERVOPACK Model	Voltage Capacity per SERVOPACK * (kVA)	Current Capacity of Circuit Breaker or Fuse (Arms)
Single-phase 100 V	SGDS-A5F	0.25	4
	SGDS-01F	0.40	4
	SGDS-02F	0.60	6
	SGDS-04F	1.20	8
Single-phase 200 V	SGDS-A5A	0.25	4
	SGDS-01A	0.40	4
	SGDS-02A	0.75	4
	SGDS-04A	1.2	8
	SGDS-08A	2.1	16
Three-phase 200 V	SGDS-10A	2.3	7
	SGDS-15A	3.2	10
	SGDS-20A	4.3	13
	SGDS-30A	5.9	17

* This is the net value at the rated load.

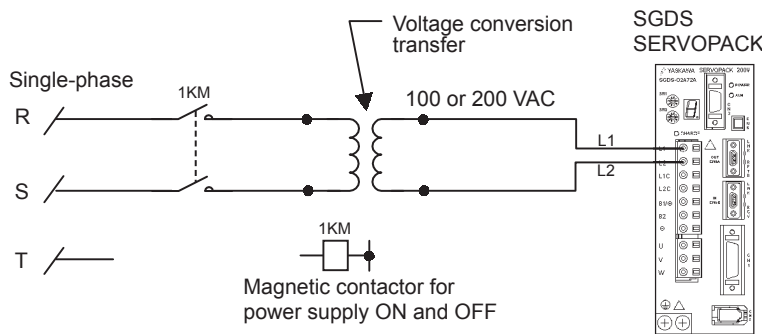

Fig. 5.1 Single-phase Power Supply Connection Example

5.4.5 AC/DC Reactor for Harmonic Suppression

(1) Reactor Types

The SGDS SERVOPACK has reactor connection terminals for power supply harmonic suppression. The type of reactor to be connected differs depending on the SERVOPACK capacity. Refer to the following table.

Applicable SERVOPACK Model SGDS-		AC/DC Reactor Model	Reactor Specifications	
			Impedance (mH)	Rated Current (A)
Single-phase, 100 V	A5F	X5053	20.0	2.0
	01F			
	02F	X5054	5.0	3.0
	04F	X5056	2.0	5.0
Single-phase, 200 V	A5A	X5052	45.0	1.0
	01A			
	02A	X5053	20.0	2.0
	04A	X5054	5.0	3.0
	08A	X5056	2.0	5.0
10A	X5061	4.8		
Three-phase, 200 V	15A	X5060	1.5	8.8
	20A			
	30A	X5059	1.0	14.0

Note: Select a proper AC or DC reactor for the input current to the SERVOPACK.

Refer to 2.5.2 *Molded-case Circuit Breaker and Fuse Capacity* for input current to each SERVOPACK. For the kind of reactor, refer to 4.4.12 *AC/DC Reactors for Harmonic Suppression*.

(2) Connecting a Reactor

Connect a reactor as shown in the following diagram.

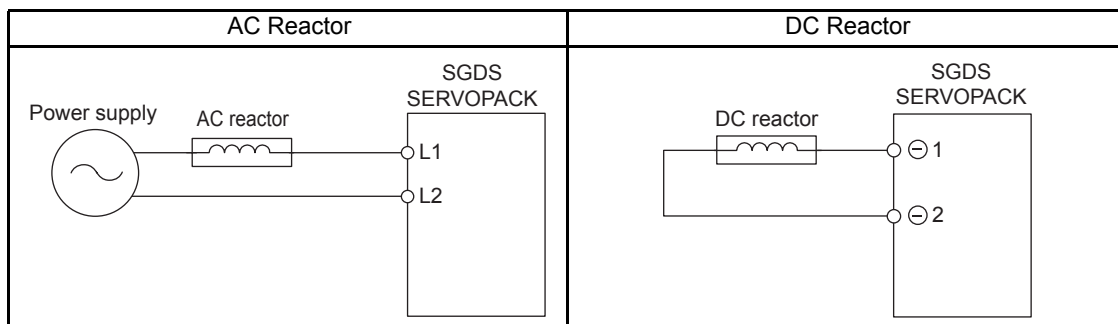

Note: 1. The DC reactor's ⊖ 1 and ⊖ 2 terminals are short-circuited before shipment. Remove the lead wire between these two terminals and connect the DC reactor.

2. AC/DC reactor is an option.

5.5 Connecting Regenerative Resistors

5.5.1 Regenerative Power and Regenerative Resistance

The rotational energy of a driven machine, such as servomotor, is returned to the SERVOPACK. This is called the regenerative power. The regenerative power is absorbed by charging the smoothing capacitor, but when the chargeable energy is exceeded, the regenerative power is further consumed by the regenerative resistor.

The servomotor is driven into the regeneration state in the following circumstances:

- While decelerating to a stop during acceleration and deceleration operation.
- With a load on the vertical axis.
- During continuous operation with the servomotor rotated from the load side (negative load).

The SERVOPACKs with a capacity of the single-phase 200 V with 50 to 400 W or 100 V with 50 to 400 W do not have built-in regenerative resistors. If the operation exceeds the rotating speed specifications shown in the 3.5.3 *Load Moment of Inertia*, connect an external regenerative resistor.

5.5.2 Connecting External Regenerative Resistors

(1) Necessity of External Regenerative Resistors

SERVOPACK Capacity	Necessity of External Regenerative Resistors
400 W or less	No built-in regenerative resistor is provided, however, normally an external regenerative resistor is not required. Install external regenerative resistors when the smoothing capacitor in SERVOPACK cannot process all the regenerative power.
750 W to 3.0 kW	A built-in regenerative resistor is provided as standard. Install external regenerative resistors when the built-in regenerative resistor cannot process all the regenerative power.

(2) Specifications of Built-in Regenerative Resistor

If the amount of regenerative energy exceeds the processing capacity of the SERVOPACK, then install an external regenerative resistor. The following table shows the specifications of the SERVOPACK's built-in resistor and the amount of regenerative power (average values) that it can process.

Main Circuit Power Supply	SERVOPACK Model		Specifications of Built-in Resistor		Regenerative Power Processed by Built-in Resistor * (W)	Minimum Allowable Resistance (Ω)
	Capacity (kW)	SGDS-	Resistance (Ω)	Capacity (W)		
Single-phase 100 V	0.05	A5F	-	-	-	40
	0.10	01F				
	0.20	02F				
	0.40	04F				
Single-phase 200 V	0.05	A5A	-	-	-	
	0.10	01A				
	0.20	02A				
	0.40	04A				
	0.75	08A				
Three-phase 200 V	1.0	10A	50	60	12	
	1.5	15A	20	50	10	
	2.0	20A	12	80	16	
	3.0	30A				

* The average regenerative power that can be handled is 20% of the rated capacity of the regenerative resistor built into the SERVOPACK.

(3) Precautions on Selecting External Regenerative Resistors

A built-in regenerative resistor is provided for 750 W to 3.0 kW SGDS SERVOPACKs as standard.

When installing an external regenerative resistor, make sure that the resistance is the same as that of the SERVOPACK's built-in resistor.

If combining multiple small-capacity regenerative resistors to increase the regenerative resistor capacity (W), select resistors so that the resistance value including error is at least as high as the minimum allowable resistance shown in the above table.

Connecting a regenerative resistor with the resistance smaller than the minimum allowable resistance may increase the current flow in the regeneration circuit, resulting in damage to the circuit.

(4) Parameter Setting

Pn600	Regenerative Resistor Capacity			
	Setting Range	Unit	Factory Setting	Setting Validation
	0 to SERVOPACK capacity	10 W	0 W	Immediately

Be sure to set this parameter when installing an external regenerative resistor.
 When set to the factory setting of "0," the SERVOPACK's built-in resistor has been used.
 Set the regenerative resistor capacity tolerance value. When the set value is improper, alarm A.320 is not detected normally. Also, do not set other than 0 without connecting the regenerative resistor because alarm A.300 or A.330 may be detected.

The set value differs depending on the cooling method of external regenerative resistor:

- For natural air cooling method: Set the value maximum 20% of the actually installed regenerative resistor capacity (W).
- For forced air cooling method: Set the value maximum 50 % of the actually installed regenerative resistor capacity (W).

Example: Set 20 W (100 W × 20%) For the 100 W external regenerative resistor with natural cooling method: Pn600 = 2 (units: 10 W)

IMPORTANT

1. When resistors for power are used at the rated load ratio, the resistor temperature increases to between 200 °C and 300 °C (392 °F and 572 °F). The resistors must be used at or below the rated values. Check with the manufacturer for the resistor's load characteristics. Use resistors at no more than 20% of the rated load ratio with natural convection cooling, and no more than 50% of the rated load ratio with forced air cooling.
2. For safety's sake, use the resistors with thermostiches.

(5) Connecting Regenerative Resistors

(a) SERVOPACKs with Capacities of 400 W or Less

Connect an external regenerative resistor between B1/⊕ and B2 terminals.

Note: The user must provide the regenerative resistor.

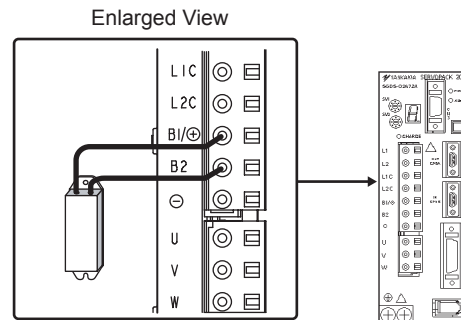

(b) SERVOPACKs with Capacities of 750 W to 3.0 kW

Disconnect the wiring between the SERVOPACK's B2 and B3 terminals and connect an external regenerative resistor between the B1/⊕ and B2 terminals.

The user must provide the regenerative resistor.

Note: Be sure to take out the lead wire between the B2 and B3 terminals.

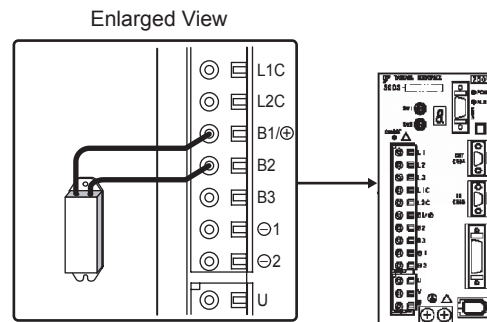
**IMPORTANT**

Do not touch the regenerative resistors because they reach high temperature. Use heat-resistant, non-flammable wiring and make sure that wiring does not touch the resistors. Refer to 4.1 *SERVOPACK Main Circuit Wire Size* for wire size for connecting an external regenerative resistor.

5.6 Flexible Cables

(1) Life of Flexible Cable

The flexible cable supports 10,000,000 or more operations of bending life with the recommended bending radius $R = 90$ mm (3.54 in) under the following test conditions.

- Conditions

1. Repeat moving one end of the cable forward and backward for 320 mm (12.60 in) using the test equipment shown in the following.
2. Connect the lead wires in parallel, and count the number of cable return motion times until a lead wire is disconnected. Note that one reciprocation is counted as one test.

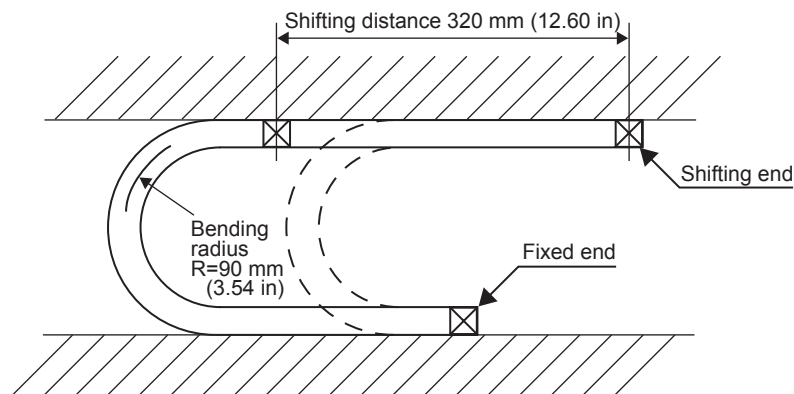

- Note: 1. The life of flexible cable differs largely depending on the amount of mechanical shocks, mounting to the cable, and fixing methods. The life of flexible cable is limited under the specified conditions.
2. The life of flexible cable indicates the number of bending times in which lead wires are electrically conducted and by which no cracks and damages that affects the performance of cable sheathing are caused. Disconnecting the shield wire is not taken into account.

(2) Wiring Precautions

Even if the recommended bending radius R is followed in the mechanical design, incorrect wiring may cause the early disconnection. Observe the following precautions when wiring.

(a) Cable Twisting

Straighten the flexible cables wiring.

Twisted cables cause the early disconnection. Check the indication on the cable surface to make sure that the cable is not twisted.

(b) Fixing Method

Do not fix the moving points of the flexible cable, or stress on the fixed points may cause early disconnection. Fix the cable at the minimum number of points.

(c) Cable Length

If the cable length is too long, it may result the cable sagging. If the cable length is too short, excessive tension on the fixed points will cause the early disconnection. Use a flexible cable with the optimum length.

(d) Interference between Cables

Avoid interference between cables.

Interference limits the motion of flexible cable, which causes early disconnection. Keep enough distance between cables, or provide a partition when wiring.

SynqNet™ Communications

6.1 Introduction	6-2
6.1.1 Overview	6-2
6.1.2 SynqNet Packet Timing	6-2
6.2 Specifications and Configurations	6-4
6.2.1 Specifications	6-4
6.2.2 SynqNet Communications Connection Example	6-4
6.2.3 Precautions for Wiring SynqNet Cables	6-5
6.2.4 Grounding	6-7
6.3 Settings	6-8
6.3.1 Switch ID Setting	6-8
6.3.2 SynqNet Port LED Indicators	6-8
6.3.3 LED 7-Segment Display	6-9
6.4 Supported SynqNet Features	6-10
6.4.1 Cyclic Commands	6-10
6.4.2 Cyclic Responses	6-10
6.4.3 Service Commands	6-11

6.1 Introduction

6.1.1 Overview

SynqNet™ is a synchronous network technology designed for multi-axis motion control applications. The physical layer of SynqNet is based on the physical layer of Ethernet. SynqNet operates over two pairs of wires, one pair for 'receive' data signals and the other pair for 'transmit' data signals. Each receiving node uses digital time-correction techniques to minimize skew and jitter. Service channel capability is used to query nodes or servo for drive parameters and status information.

6.1.2 SynqNet Packet Timing

SynqNet is unlike other synchronous digital servo network protocols in the way that command and response messages are handled. With other servo networks, the cyclic and service channel commands and responses are usually handled in a single data packet per controller cycle. In SynqNet, the cyclic data demands, cyclic data responses, service channel demands, and service channel responses may occur in separate communication buffers during the controller cycle. This is implemented by utilizing a drive update period (drive cycle) that is faster than the controller cycle. The communications buffer is checked by the drive every drive cycle. An integral number of drive cycles must make up one controller cycle.

In other servo networks, the data packet size and node time slots are usually fixed. This is neither true with SynqNet nor PROFIBUS. During startup network configuration, the SynqNet controller determines when in each controller cycle the individual nodes will receive new demands and when the responses will be read. The resolution of the SynqNet node communication scheduling is 40 nanoseconds. Each node may have a different packet size depending on the number of axes supported.

During every SynqNet controller cycle every axis in every node will receive a new cyclic demand. All drives are notified of new cyclic data at the same time via a strobe mechanism.

During a SynqNet controller cycle there may be one service channel request per node. Since a node may have multiple axes, it is not possible to handle service channel requests for multiple axes at the same node during the same controller cycle. The service channel request may not occur during the same drive cycle as the cyclic demand.

The main advantage of this architecture is that the time from controller update until drive update is minimized. Also, the time from drive position update to new controller update is also minimized.

The following figure illustrates the relationship between the SynqNet data interchange over the wire and the drive message buffer updates.

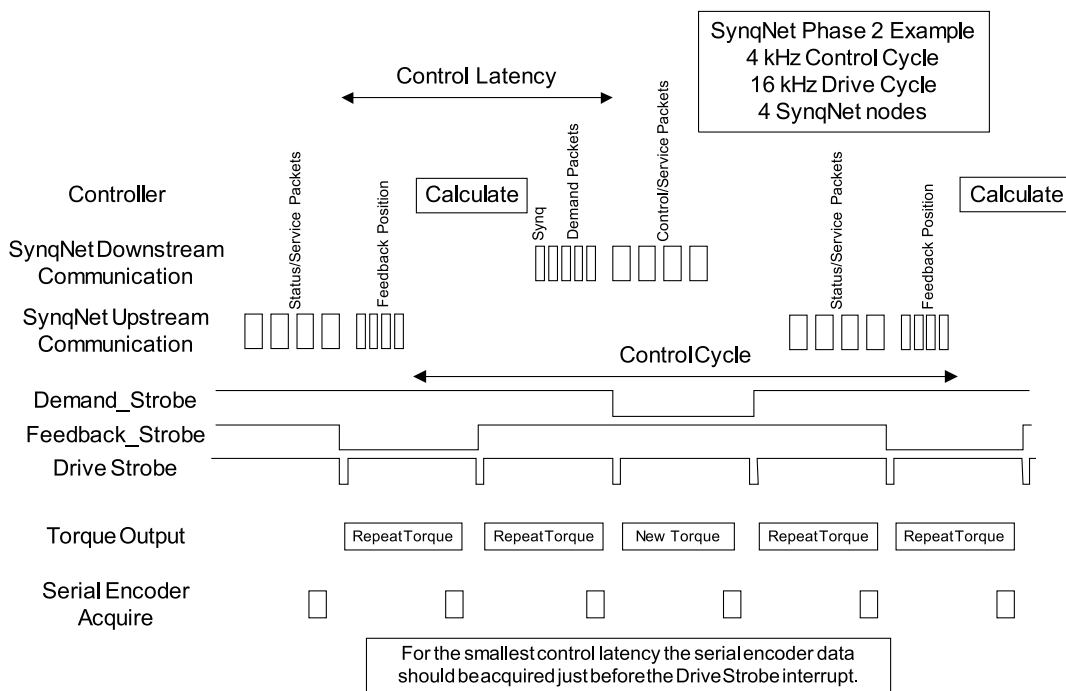

6.2 Specifications and Configurations

6.2.1 Specifications

Item	Specification
Buffer Update Rate	16 kHz
Node Coordination	Support for up to 32 coordinated axes
Topology	Ring or String

6.2.2 SynqNet Communications Connection Example

(1) Configuration Elements

(a) Controller

The controller is the SynqNet network host. There should only be one controller per network.

(b) Nodes

A node is a slave and not the controller, unless otherwise stated.

(c) Terminator

An optional loopback connector placed at the end of a node chain in a string topology.

(2) Topology

SynqNet supports a ring topology where the network nodes are connected in series back to the SynqNet controller.

In a ring topology, if any one cable or node fails, the network will redirect packet data around the break and notify the application with an event. The location of the break can be determined by the application.

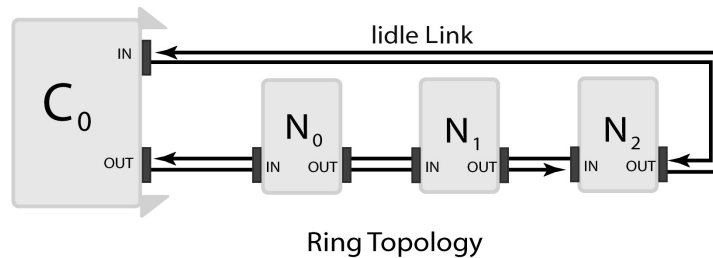

String topology (opened or terminated) is also supported where the network nodes are not connected back to the SynqNet controller. If a cable breaks, the nodes downstream from the break will no longer be able to send/receive packets to/from the controller. The advantage of using a terminator on the last node is that the network initialization time is reduced, because the controller can deterministically find the last node on a network. Both string topology types do not support fault recovery.

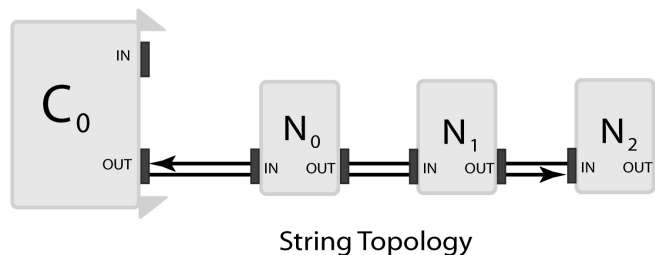

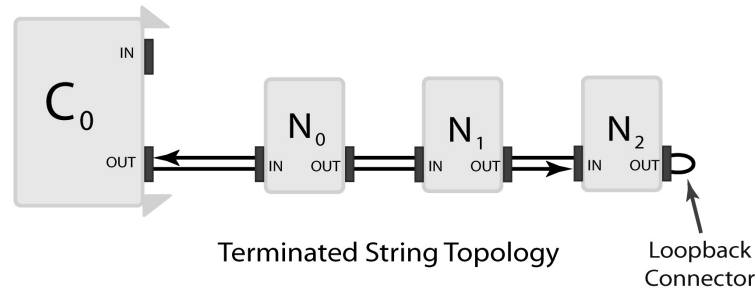

6.2.3 Precautions for Wiring SynqNet Cables

(1) Cable Length

The SynqNet cable lengths are derived from the measured propagation delays during network initialization. This information is used to determine the spacing between packets for each node. SynqNet networks can have up to 32 nodes and cables can be up to 100 meters in length. By measuring the actual propagation delays and optimizing the packet spacing, the network performance and actual bandwidth is improved.

Typical CAT5 cable propagation delays are roughly 0.005 microsec per meter. Actual values are affected by cable construction and will vary, but the variation will be small for any reasonable cable. The propagation delay can be estimated by a cable propagation velocity of 70% the speed of light, using the formula:

$$\text{delay} = \text{meters} * 1,000,000 / (0.7 * 299,722,458)$$

For example, here are some rough values for various cable lengths:

Length (m)	Time (μs)
1	0.005
10	0.048
25	0.119
50	0.238
100	0.477

During SynqNet initialization the controller sends a packet to each node, waits for the node to repeat the packet back, and measures the elapsed time. In ring topologies, the last cable requires the packet to travel around the network and return to the controller. The controller reads the clock values for each measurement packet and stores the values. The raw time values are then converted into cable length (meters), and the propagation delays are used to calculate the packet spacing.

The propagation delay measurement is based on the SynqNet clock rate, which is 25MHz (period = 0.040 microseconds). At 25MHz, the clock resolution is 0.040 microseconds, which translates to roughly 8 meters. The accuracy is based on the forwarding variations for each node (+/- 1 clock) and the resolution of the propagation delay timer (+/- 0.5 clocks). The accuracy for each cable can be determined from:

$$\text{accuracy} = ((.020 \text{ microsec}) + (.040 \text{ microsec} * \text{nodeCount})) / 2$$

in terms of meters:

$$\text{accuracy} = ((4 \text{ meters}) + (8 \text{ meters} * \text{nodeCount})) / 2$$

For example, a network with 3 nodes has following cable length accuracies:

Cable	Resolution + Variation = Accuracy
0	$(.02 + .04)/2 = +/- .03 \text{ microsec} (+/- 16 \text{ meters})$
1	$(.02 + .08)/2 = +/- .05 \text{ microsec} (+/- 10 \text{ meters})$
2	$(.02 + .12)/2 = +/- .07 \text{ microsec} (+/- 14 \text{ meters})$

In some servo networks, the system designer may want to optimize the packet spacing by configuring the cable length values. Most networks will not need this type of optimization. The SynqNet network has maximum, minimum, and nominal cable length configurations. Changing these configurations will affect the packet spacing calculations and the topology mismatch checking. During network initialization, if a measured cable length is not between the minimum and maximum values, a Topology Mismatch error will be returned.

A break-free cable performs much better than one with an in-line coupler. Even those couplers that offer continuity of the shield do so in an inadequate fashion and should be avoided.

During network initialization, the nominal cable lengths will be measured and the minimum and maximum values will be calculated. The minimum cable length will be set to the nominal - 8 meters. The maximum cable length will be set to the nominal + 8 meters. During subsequent network initializations, the measured cable length will be compared to the minimum and maximum values. If the measured cable length is not between the minimum and maximum values, a Topology Mismatch error will be returned. To recover, use a control reset to clear the previous minimum and maximum cable values, re-initialize the network, and set the new min/max values.

(2) Micro-D Connections

SGDS SynqNet utilizes Micro-D connectors to interconnect the nodes and the controller. See section 5.3.4 *SynqNet Connectors (CN6A and CN6B)* for Micro-D pin arrangements. The cabling scheme uses straight through cables. The crossover of transmit and receive is carried out at the connectors. These two pinouts have been named the "OUT" port and the "IN" port to assist in the setup of hardware, but remember that each port is full duplex and has the ability to transmit and receive data.

(3) Cable Shielding

SynqNet defines cable shielding conventions in order to properly isolate local node signals and power while minimizing EMI (both emission and reception). Shielded cabling will reduce EMI coupled from other devices in the system. The cables shall have their shields connected to the metal connector shell using the clamp on the Micro-D connector. Cable shield connections are treated slightly differently at the controller and node PCBs. Both are detailed below.

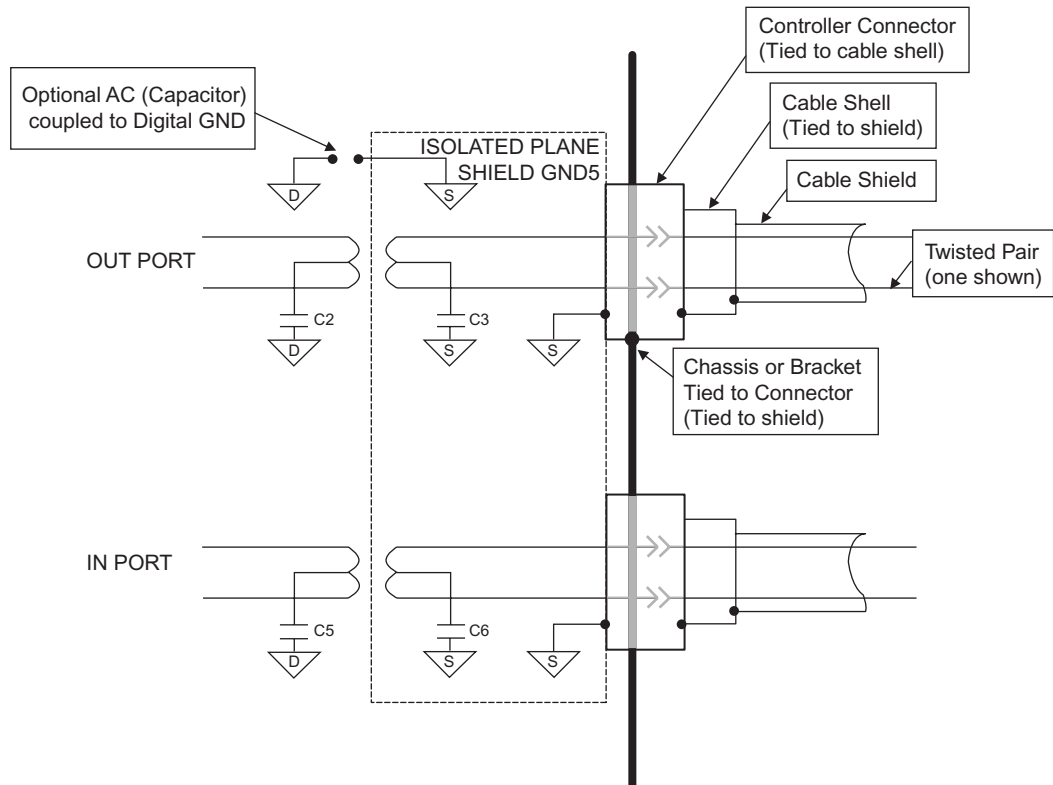

(4) Node Shielding

Node shielding is DC isolated from port to port and from local node chassis, as well as from ground and power signals. (Molex offers an insulated screened connector: PN 85504.) This prevents currents at DC or main frequency from circling the ring, or coming back via some system ground path. The shields are AC coupled via capacitors (one for each port) to a nearby earth point on the node and/or machine chassis. This capacitor reduces EMI by dumping high frequency energy to the earth ground. The cable shields are also tied to isolated plane sections (one for each port) on the node PCB to minimize EMI.

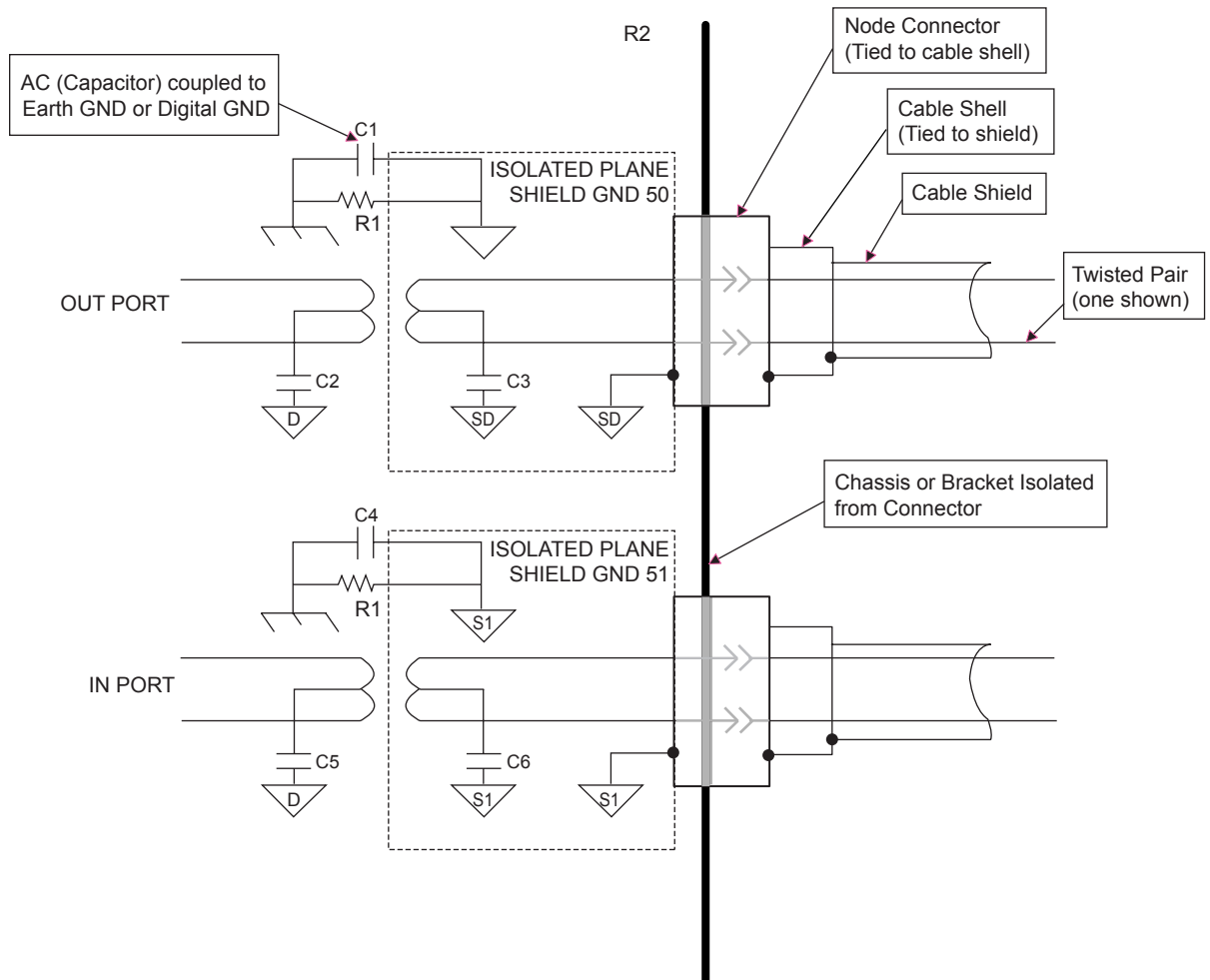

6.2.4 Grounding

SynqNet provides grounding of its communication lines through the connectors. Each connection includes ground lines for the transmit line and the receive line, as well as earth ground.

For proper machine grounding details, see section 5.4.2 *Wiring for Noise Control*.

6.3 Settings

6.3.1 Switch ID Setting

SynqNet does not require any hardware setting for node address because node addresses are assigned by the controller to each node. However, a switch ID setting may be required for higher level applications. To set the switch ID for applications, use the rotary switches (SW1 and SW2) on the SERVOPACK's front panel. After making the settings, the application should re-read the switch ID.

Each rotary switch has 16 positions from hexadecimal 0 through F, so there are 256 possible settings. The switch ID value is stored in a 32-bit address within the FPGA of the node; the upper 16 bits or the first 2 digits of the 4-digit hexadecimal value are the rotary switch settings of SW1 and SW2, respectively.

Table 6.1 Example Switch ID Settings

Rotary Switch		Switch ID	Rotary Switch		Switch ID
SW1	SW2		SW1	SW2	
0	0	0x00##	1	2	0x12##
0	1	0x01##	9	A	0x9A##
0	A	0x0A##	F	F	0xFF##

6.3.2 SynqNet Port LED Indicators

Each SynqNet port has two LEDs. The LEDs specifically relate to the FPGA and network states. They function independently from the drive processors or other devices attached to the node. The normal state of the LEDs during normal operation is to be continuously lit.

Table 6.2 Out Port LED Indicators

LED	Meaning	Description	
LNK (LED 3)	Link Activity	ON	Link Active (Normal Operation)
		OFF	Link Inactive
RPTR (LED 4)	Repeater State	ON	SYNQ operation [Repeater ON]
		OFF	Unpowered, Reset, Undiscovered, Inactive State, Repeater OFF
		Blink 0.75 Hz	Discovered State [Repeater ON]
		Blink 1.5 Hz	SYNQ Lost [Repeater ON]

Table 6.3 In Port LED Indicators

LED	Meaning	Description	
LNK (LED 1)	Link Activity	ON	Link Active (Normal Operation)
		OFF	Link Inactive
RCV (LED 2)	Receive State	ON	SYNQ operation
		OFF	Unpowered, Reset, Inactive State
		Blink 0.37 Hz	Undiscovered State
		Blink 0.75 Hz	Discovered State
		Blink 1.5 Hz	SYNQ Lost

6.3.3 LED 7-Segment Display

The state of the SERVOPACK is shown in the 7-segment LED display.

The status of the SERVOPACK is displayed as follow.

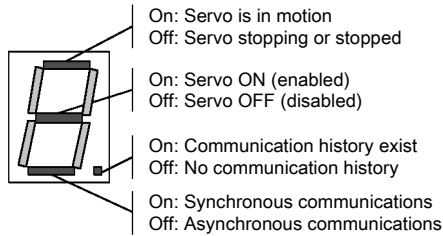

Only the Servo OFF light segment will light up before connecting to the network after turning on the power supply.

The following displays are alternately lit at P_OT and N_OT status.

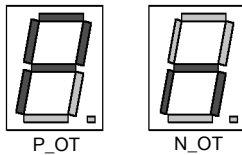

When an alarm is generated, the alarm code digits are alternately lit as the status.

For example, "A.123":

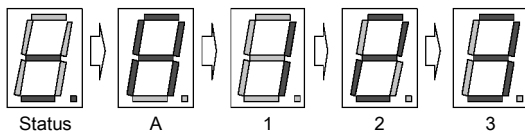

6.4 Supported SynqNet Features

The SGDS SynqNet SERVOPACK performs cyclic operations. Commands are sent and responses are retrieved during every control cycle.

The following sections list the supported SynqNet functions.

6.4.1 Cyclic Commands

All cyclic commands are executed every control cycle.

(1) Torque

Sets torque value. Scale: 10,000 units = 100% rated torque.

(2) Amp Enable/Disable

Sets servo to enabled or disabled state.

6.4.2 Cyclic Responses

All cyclic responses are received every control cycle and are available in the node response buffer.

(1) Drive Ready

Shows that communications are active. Valid at all times.

(2) Encoder Ready

Shows that the serial encoder is communicating correctly in synchronous mode. Valid when the Drive Ready response appears.

(3) Amp Powered

Shows that motor voltage is available to drive the servo. Valid when the Drive Ready response appears.

(4) Servo ON

Shows that servo is enabled or disabled. Will not be set if drive is disabled either by turning the PWM off or by dynamic braking. Valid when Drive Ready is set.

(5) Torque Limit

Shows that the Torque Reference is over the Torque Limit. Valid when the Drive Ready response appears.

(6) Warning

Warns that precautions must be taken to prevent a fault or error. Valid at all times.

(7) Fault

Shows that a fault has shut down the amplifier. To determine the fault cause, the error code needs to be read using a memory operation. Valid at all times.

(8) Position Feedback

Returns a 32-bit position value at every control cycle.

(9) Monitor_A / Torque Echo

Shows that the torque value at every control cycle is returned.

(10) Monitor_C / Multi-turn Data

Returns a 16-bit multi-turn data value.

6.4.3 Service Commands

Two types of additional operations are available, Direct Commands and Memory Operations. Different settings are used to distinguish if a direct command is being issued or not, and to distinguish the type of memory being accessed. The setting for the read or write functions setting will apply to all Memory Operations as well as some Direct Commands.

For more information on operating methods, refer to the MEI SynqNet Controller manuals.

(1) Memory Operations

Motor capacity, motor models, encoder resolution, and alarm history data can be read.

(2) Direct Commands

The following direct commands are supported by SGDS SynqNet.

Table 6.4 Supported Direct Commands

Name	Meaning
Read Alarm (Read)	Reads an alarm code from the alarm history.
Alarm Count (Read)	Reads the number of active alarms stored in alarm history buffer.
Clear Alarm (Write)	Clears all alarms in the active alarm list that may be cleared. See the Alarms table for a list of alarms that can be cleared. If all the alarms in the alarm list can be cleared then the fault line is deasserted, the Fault flag response will be cleared, and the servo will be enabled if the hardware enable line is asserted and the Amp Enable is set.
Read Warning	Returns a warning code from the warning list.
Warning Count (Read)	Reads the number of warnings stored in warnings list.
Clear Warning (Write)	Clears all warnings.
Multi-turn Count Read	Reads the 16-bit multi-turn value.
Multi-turn Count Clear (Write)	Resets the serial encoder multi-turn data. Also will clear alarm 0810H, encoder backup error. Requires a SynqNet reset afterwards.

Operation

This chapter explains the JOG operation, parameter settings, and the Multiturn Limit setting when using the digital operator. For more information on operating methods, refer to the MEI SynqNet controller manuals.

7.1 Trial Operation	-----7-2
7.1.1 Digital Operator Operation	----- 7-2

7.1 Trial Operation

7.1.1 Digital Operator Operation

The digital operator can be used to operate the servomotor and to perform other functions such as the multi-turn reset.

(1) Operate with the Digital Operator

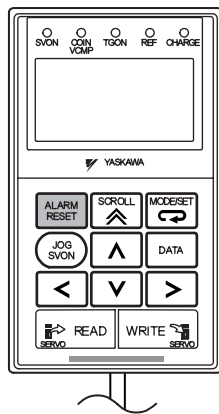

Use the digital operator to operate the servomotor with utility function Fn002 (Jog Mode Operation). The factory setting for jog operation is 500 min^{-1} .

Check to see if the servomotor runs normally.



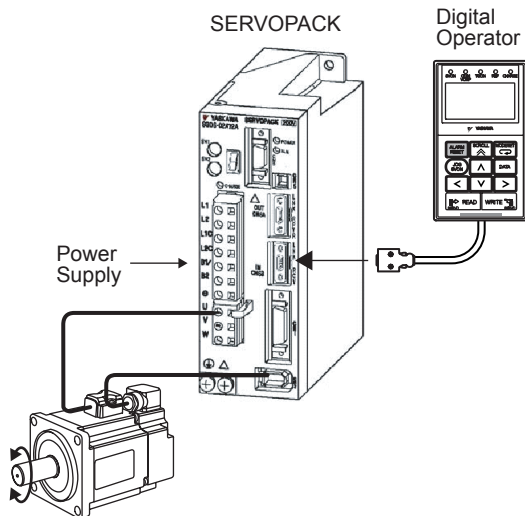











The operating procedure is given below.



























The motor can be operated using only the digital operator. This makes it possible to check the servomotor rotation direction and set the speed during machine setup and trial operation without connecting the host controller.

* When operating the servomotor with the digital operator, a parameter can be used to change the servomotor speed, as described below.









Parameter: Pn304, Unit: min^{-1} , Standard setting: 500 min^{-1}

Operation Key	Display	Description
  	BB -FUNCTION- Fn001 <u>Fn002</u> Fn003 Fn004	Display the main menu of the utility function mode, and select the utility function Fn002.
	BB -JOG- Pn304 = 00500 Un000 = 00000 Un002 = 00000 Un00D = 00000000	Press the  Key. Then, the screen changes and shows switches to the execution display of a jog operation (Fn002). * If the screen does not change, and NO-OP is displayed in the status display section, a write prohibited password has been saved in Fn010. Clear the write prohibited password if possible.
	RUN -JOG- Pn304 = 00500 Un000 = 00000 Un002 = 00000 Un00D = 00000000	Press the  Key. The status display changes to RUN, and the motor enters a servo ON state.
 	RUN -JOG- Pn304 = 00500 Un000 = 00000 Un002 = 00000 Un00D = 00000000	If the  Key is pressed, the motor moves forward at 500 min ⁻¹ . If the  Key is pressed, the motor moves in reverse at 500 min ⁻¹ .
	BB -JOG- Pn304 = 00500 Un000 = 00000 Un002 = 00000 Un00D = 00000000	Make sure that the motor operation is completed, and then press the  Key. The status display changes to BB, and the motor enters a servo OFF state.
	BB -FUNCTION- Fn001 <u>Fn002</u> Fn003 Fn004	Press the  Key. Returns to the main menu of the utility function mode.

(2) Parameter Set

Operation Key	Display	Description
  	BB -FUNCTION- Fn001 <u>Fn002</u> Fn003 Fn004	Display the main menu of the utility function mode, and select the utility function Fn002.
	BB -JOG- Pn304 = 00500 Un000 = 00000 Un002 = 00000 Un00D = 00000000	Press the  Key. Then, the screen changes and shows switches to the execution * If the screen does not change, and NO-OP is displayed in the status display section, a write prohibited password has been saved in Fn010. Clear the write prohibited password if possible.
   	BB -JOG- Pn403 = 08000 Un000 = 00000 Un002 = 00000 Un00D = 00000000	Press the  Key or the  Key to select the appropriate parameter number digit. Press the  Key or the  Key to change the digit value.
	BB -JOG- Pn403 = 0800 <u>0</u> Un000 = 00000 Un002 = 00000 Un00D = 00000000	Press the  Key. Cursor moves from the parameter number to the parameter value.
   	BB -JOG- Pn403 = 00 <u>2</u> 00 Un000 = 00000 Un002 = 00000 Un00D = 00000000	Press the  Key or the  Key to select the appropriate value digit. Press the  Key or the  Key to change the digit value.
	BB -FUNCTION- Fn001 <u>Fn002</u> Fn003 Fn004	Press the  Key. Returns to the main menu of the auxiliary function mode.
<p>Note: 1. For more information on operating method, refer to the Σ-III series SGM□S/SGDS Digital Operator Instructions (Manual No. TOBP S80000 01).</p> <p>2. Some parameters require the power supply to be turned OFF and then turned ON again to enable the function. See 10.1.1 List of Parameters for full listing.</p>		

(3) Multi-turn Reset

Operation Key	Display	Description
  	A. 810 -FUNCTION- Fn007 <u>Fn008</u> Fn009 Fn00A	Display the main menu of the utility function mode, and select Fn008.
	A810 Multiturn Clear PGCL1	Press the  Key. Then, the screen changes and shows execution display of Fn008.
	A. 810 Multiturn Clear PGCL5	Press the  Key until PGCL5 appears.
	DONE Multiturn Clear PGCL5	Press the  Key to clear the multi-turn data of the absolute encoder. DONE is displayed for one second after the setting have been made.
Turn OFF the power supply and then turn it ON again to enable the settings.		



Adjustments

8.1 Torque Filters	-----	8-2
8.2 Analog Monitor	-----	8-5

8.1 Torque Filters

As shown in the following diagram, the torque reference filter contains three torque reference filters and two notch filters arrayed in series, and each filter operates independently. The notch filters can be enabled and disabled with the parameters.

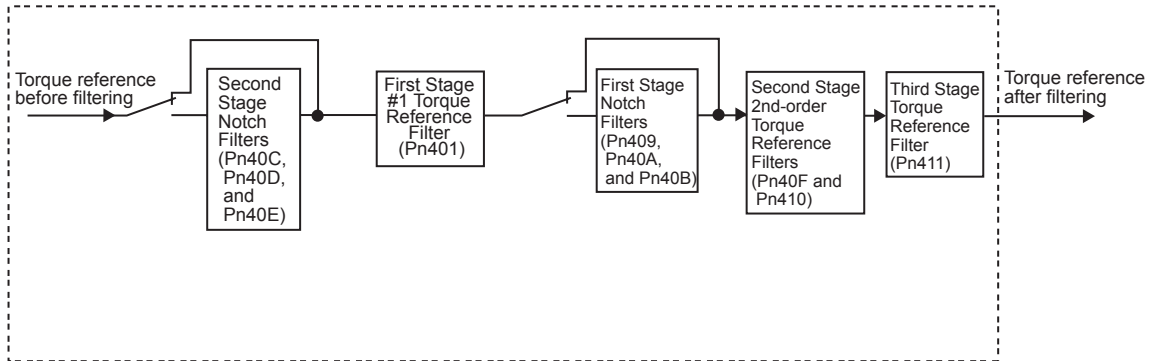

(1) Torque Reference Filter

If you suspect that machine vibration is being caused by the servodrive, try adjusting the filter time constants. This may stop the vibration. The lower the value, the better the speed control response will be, but there is a lower limit that depends on the machine conditions.

Pn401	First stage #1 torque reference filter			
	Setting Range	Setting Unit	Factory Setting	Setting Validation
	0.00 to 655.35 ms	0.01 ms	1.00 ms	Immediately
Pn40F	Second stage 2nd-order torque reference filter frequency			
	Setting Range	Setting Unit	Factory Setting	Setting Validation
	100 to 2,000 Hz	1 Hz	2,000 Hz	Immediately
Pn410	Second stage 2nd-order torque reference filter Q value			
	Setting Range	Setting Unit	Factory Setting	Setting Validation
	0.50 to 10.00 Hz	0.01	0.70	Immediately
Pn411	Third stage torque reference filter			
	Setting Range	Setting Unit	Factory Setting	Setting Validation
	0 to 65,535 μ s	1 μ s	0 μ s	Immediately

Note: 1. The setting units for the third stage torque reference filter are different from the units for the first and second stage filters.

2. The second stage 2nd-order torque reference filter is disabled when parameter Pn40F (Second Stage 2nd-order Torque Reference Filter Frequency) is set to its factory setting of 2,000 Hz.

(2) Notch Filter

The notch filter can eliminate specific frequency vibration generated by sources such as resonances of ball screw axes. The notch filter puts a notch in the gain curve at the specific frequency vibration. The frequency components near the notch frequency can be eliminated with this characteristic. A higher notch filter Q value produces a sharper notch and phase delay.

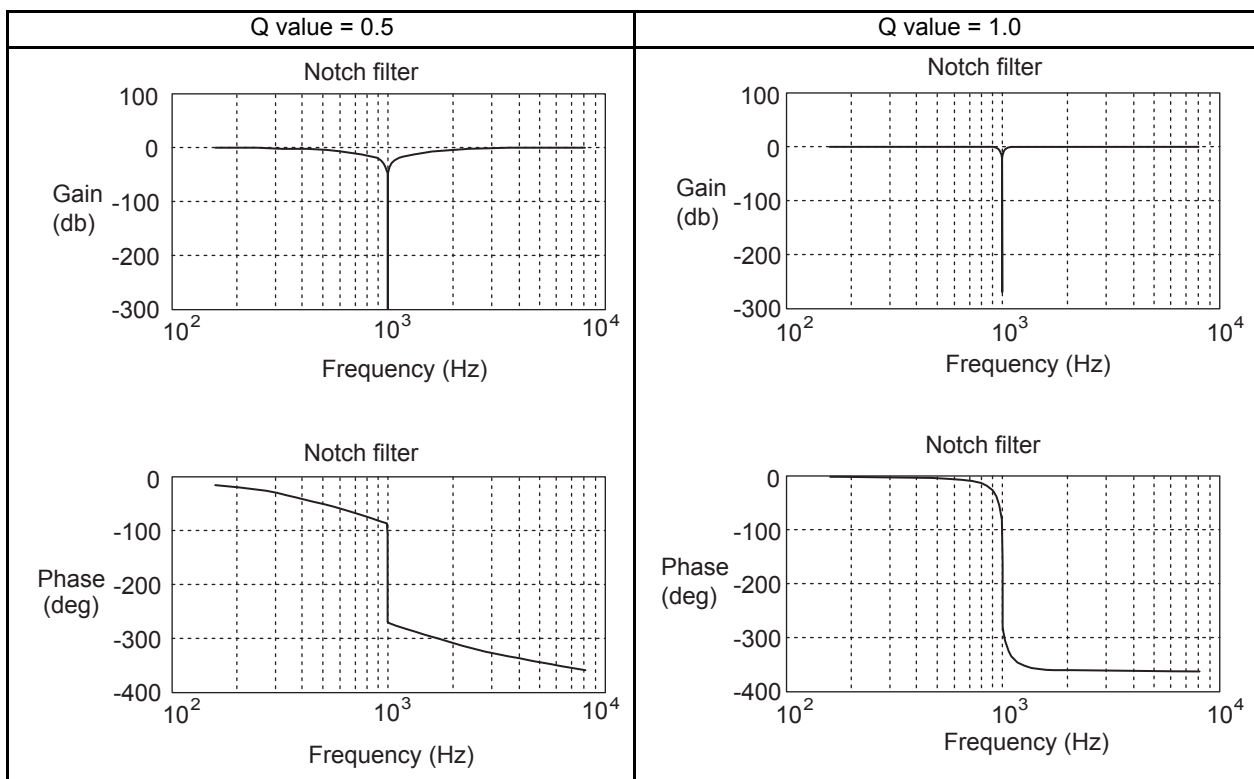

Parameter	Meaning	
Pn408	n.□□□0	First stage notch filter disabled.
	n.□□□1	First stage notch filter is used.
	n.□0□□	Second stage notch filter disabled.
	n.□1□□	Second stage notch filter is used.
Used notch filters are enabled. (It isn't necessary to turn the power OFF and ON again.)		

Set the machine's vibration frequency in the parameter of a notch filter that is being used.

Pn409	First Stage Notch Filter Frequency			
	Setting Range	Setting Unit	Factory Setting	Setting Validation
	50 to 2,000 Hz	1 Hz	2,000 Hz	Immediately
Pn40C	Second Stage Notch Filter Frequency			
	Setting Range	Setting Unit	Factory Setting	Setting Validation
	50 to 2,000 Hz	1 Hz	2,000 Hz	Immediately

When the vibration is suppressed but overshooting occurs, increase the Q value and check whether the overshooting is corrected.

Pn40A	First Stage Notch Filter Q Value			
	Setting Range	Setting Unit	Factory Setting	Setting Validation
	70 to 1000 (0.70 to 10.00)	0.01	70 (0.70)	Immediately
Pn40D	Second Stage Notch Filter Q Value			
	Setting Range	Setting Unit	Factory Setting	Setting Validation
	70 to 1000 (0.70 to 10.00)	0.01	70 (0.70)	Immediately

IMPORTANT

Change the Notch Filter Frequency (Pn409 or Pn40C) only when the motor is stopped. Vibration may occur if the notch filter frequency is changed when the motor is rotating.

8.2 Analog Monitor

Signals for analog voltage references can be monitored.

To monitor analog signals, connect the analog monitor cable (JZSP-CA01) to the connector CN5.

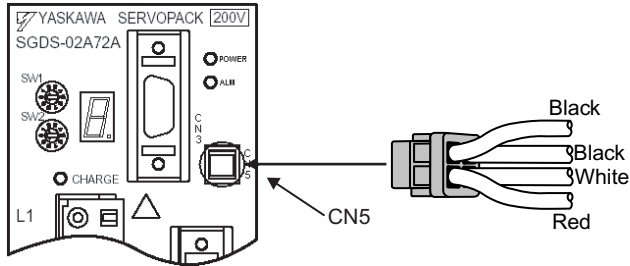

Line Color	Signal Name	Description
White	Analog monitor 1	Torque reference: 1 V/100% Rated torque
Red	Analog monitor 2	Motor speed: 1 V/1000 min ⁻¹
Black (2 lines)	GND (0 V)	Analog monitor GND: 0 V

The analog monitor signals can be changed by setting parameters Pn006.0,1 and Pn007.0,1.

The output voltages on analog monitor 1 and 2 are set as shown below.

$$\text{Analog monitor 1 output voltage} = \{(-1) \times \text{Signal selection} \times \text{Signal multiplier}\} + \text{Offset voltage [V]}$$

Pn006=□□XX
Pn006=□X□□
Pn550

$$\text{Analog monitor 2 output voltage} = \{(-1) \times \text{Signal selection} \times \text{Signal multiplier}\} + \text{Offset voltage [V]}$$

Pn007=□□XX
Pn007=□X□□
Pn551

(1) Related Parameters

The following signals can be monitored.

(a) Pn006 and Pn007: Function Selections

Parameter		Description		
		Monitor Signal	Measurement Gain	Remarks
Pn006 Pn007	n.□□00	Motor speed	1 V/1000 min ⁻¹	Pn007 Factory Setting
	n.□□01	Reserved	–	–
	n.□□02	Gravity Compensation Torque (Pn422) subtract from Torque Reference	1 V/100% Rated torque	Pn006 Factory Setting
	n.□□03	Reserved	–	–
	n.□□04	Reserved	–	–
	n.□□05	Reserved	–	–
	n.□□06	Reserved	–	–
	n.□□08	Reserved	–	–
	n.□□0B	Reserved	–	–
	n.□□0C	Reserved	–	–
	n.□□0D	Reserved	–	–
	n.□□0E	Reserved	–	–
	n.□□0F	Reserved	–	–

The monitor factor can also be changed by setting parameters Pn006.2 and Pn007.2.

Parameter	Multiplier	Remarks
Pn006	n.□0□□	×1
Pn007	n.□1□□	×10
	n.□2□□	×100
	n.□3□□	×1/10
	n.□4□□	×1/100

Pn550	Analog Monitor 1 Offset Voltage			
	Setting Range	Setting Unit	Factory Setting	Setting Validation
	-1000.0 to 1000.0 (-1000.0 to 1000.0)	0.1 V	0 (0.0 V)	Immediately
Pn551	Analog Monitor 2 Offset Voltage			
	Setting Range	Setting Unit	Factory Setting	Setting Validation
	-1000.0 to 1000.0 (-1000.0 to 1000.0)	0.1 V	0 (0.0 V)	Immediately

■ Example

If Pn006 = 0102, Pn422 = 10.00 [%], and Pn550 = 3.00 [V], then

Analog Monitor 1 = Torque reference

$$= \{(-1) \times (\text{Torque reference [\%]} - 10\%) \times 10\} + 3[\text{V}]$$

If the torque is 2%,

$$= \{(-1) \times (52 [\%] - 10 [\%]) \times \frac{1 [\text{V}]}{100 [\%]} \times 10\} + 3 [\text{V}] = -7.2 [\text{V}] \text{ (Analog Monitor 1 output voltage)}$$



The analog monitor output voltage is ± 8 V (maximum). The output will be limited to ± 8 V even if this value is exceeded in the above calculations.

Inspection, Maintenance, and Troubleshooting

9.1 Troubleshooting	9-2
9.1.1 Alarm Display Table	9-2
9.1.2 Warning Displays	9-4
9.1.3 Troubleshooting of Alarm and Warning	9-5
9.1.4 Troubleshooting for Malfunction without Alarm Display	9-17
9.2 Inspection and Maintenance	9-21
9.2.1 Servomotor Inspection	9-21
9.2.2 SERVOPACK Inspection	9-21
9.2.3 SERVOPACK's Parts Replacement Schedule	9-22

9.1 Troubleshooting

9.1.1 Alarm Display Table

A summary of alarm displays is given in Table 9.1.

If an alarm occurs, the servomotor can be stopped by doing either of the following operations.

- DB STOP: Stops the servomotor immediately using the dynamic brake.
- ZERO-SPEED STOP: Stops the servomotor by setting the speed reference to “0.”

Table 9.1 Alarm Display Table

Alarm Display	Alarm Name	Meaning	Servomotor Stop Method	Alarm Reset	Servo Alarm (ALM) Output
A.020	Parameter Checksum Error	EEPROM data of SERVOPACK is incorrect.	DB stop	N/A	H
A.021	Parameter Format Error	Parameter data of SERVOPACK is incorrect.	DB stop	N/A	
A.022	System Checksum Error	Parameter data of SERVOPACK is incorrect.	DB stop	N/A	
A.023	Parameter Password Error	Parameter data of SERVOPACK is incorrect.	DB stop	N/A	
A.030	Main Circuit Detector Error	Detection data for power circuit is incorrect.	DB stop	Available	
A.040	Parameter Setting Error	The parameter setting is outside the allowable setting range.	DB stop	N/A	
A.042	Parameter Combination Error	Combination of some parameters exceeds the setting range.	DB stop	N/A	
A.050	Combination Error	SERVOPACK and servomotor capacities do not match each other.	DB stop	Available	
A.051	Unsupported Product Alarm	The serial converter unit unsupported was connected.	DB stop	N/A	
A.0b0	Servo ON reference Invalid Alarm	The Host controller reference was sent to turn the Servo ON after the Servo ON function was used with the Digital Operator or SigmaWin+.	DB stop	Available	
A.100	Overcurrent or Heat Sink Overheated	An overcurrent flowed through the IGBT. Heat sink of SERVOPACK was overheated.	DB stop	N/A	
A.300	Regeneration Error Detected	Regenerative circuit or regenerative resistor is faulty.	DB stop	Available	
A.320	Regenerative Overload	Regenerative energy exceeds regenerative resistor capacity.	DB stop	Available	
A.330	Main Circuit Power Supply Wiring Error	The power supply to the main circuit does not match the parameter Pn001 setting.	DB stop	Available	
A.400	Overvoltage	Main circuit DC voltage is excessively high.	DB stop	Available	
A.410	Undervoltage	Main circuit DC voltage is insufficiently low.	DB stop	Available	
A.510	Overspeed	Rotational speed of the motor is excessively high.	DB stop	Available	
A.710	Overload: High Load	The motor was operating for several seconds to several tens of seconds under a torque largely exceeding ratings.	DB stop	Available	
A.720	Overload: Low Load	The motor was operating continuously under a torque largely exceeding ratings.	DB stop	Available	
A.730	Dynamic Brake Overload	When the dynamic brake was applied, rotational energy exceeded the capacity of dynamic brake resistor.	DB stop	Available	
A.740	Overload of Surge Current Limit Resistor	The main circuit power was frequently turned ON and OFF.	DB stop	Available	
A.7A0	Heat Sink Overheated	The heat sink of SERVOPACK overheated.	DB stop	Available	
A.810	Encoder Backup Error	All the power supplies for the absolute encoder have failed and position data was cleared.	DB stop	N/A	

Table 9.1 Alarm Display Table (Cont'd)

Alarm Display	Alarm Name	Meaning	Servomotor Stop Method	Alarm Reset	Servo Alarm (ALM) Output	
A.820	Encoder Checksum Error	The checksum results of encoder memory is incorrect.	DB stop	N/A	H	
A.830	Absolute Encoder Battery Error	Battery voltage for the absolute encoder has dropped.	DB stop	Available		
A.840	Encoder Data Error	Data in the encoder is incorrect.	DB stop	N/A		
A.850	Encoder Overspeed	The encoder was rotating at high speed when the power was turned ON.	DB stop	N/A		
A.860	Encoder Overheated	The internal temperature of encoder is too high.	DB stop	N/A		
A.b31	Current Detection Error1	Phase-U current sensor is faulty.	DB stop	N/A		
A.b32	Current Detection Error 2	Phase-V current sensor is faulty.	DB stop	N/A		
A.b33	Current Detection Error 3	Phase-W current sensor is faulty.	DB stop	N/A		
A.bF0	System Alarm 0 (Internal program processing error)	“Internal program error 0” of SERVOPACK occurred.	DB stop	N/A		
A.bF1	System Alarm 1 (Internal program processing error)	“Internal program error 1” of SERVOPACK occurred.	DB stop	N/A		
A.bF2	System Alarm 2 (Internal program processing error)	“Internal program error 2” of SERVOPACK occurred.	DB stop	N/A		
A.bF3	System Alarm 3 (Internal program processing error)	“Internal program error 3” of SERVOPACK occurred.	DB stop	N/A		
A.bF4	System Alarm 4 (Internal program processing error)	“Internal program error 4” of SERVOPACK occurred.	DB stop	N/A		
A.C10	Servo Overrun Detected	The servomotor ran out of control.	DB stop	Available		
A.C80	Absolute Encoder Clear Error and Multi-turn Limit Setting Error	The multi-turn for the absolute encoder was not properly cleared or set.	DB stop	N/A		
A.C90	Encoder Communications Error	Communications between SERVOPACK and encoder is not possible.	DB stop	N/A		
A.C91	Encoder Communications Position Data Error	An encoder position data calculation error occurred.	DB stop	N/A		
A.C92	Encoder Communications Timer Error	An error occurred in the communications timer between the encoder and the SERVOPACK.	DB stop	N/A		
A.CA0	Encoder Parameter Error	Encoder parameters are faulty.	DB stop	N/A		
A.Cb0	Encoder Echoback Error	Contents of communications with encoder is incorrect.	DB stop	N/A		
A.CC0	Multi-turn Limit Disagreement	Different multi-turn limits have been set in the encoder and SERVOPACK.	DB stop	N/A		
A.d00	Position Error Pulse Overflow	Position error pulse exceeded parameter (Pn520).	DB stop	Available		
A.E02	ASIC Interrupt Communication Error	Not able to communication between ASIC Interrupt and SERVOPACK.	DB stop	N/A		
A.E0A	FPGA WDC Error	FPGA Watchdog malfunction	DB stop	Available		
A.E60	SynqNet Communication Error	SynqNet and SERVOPACK are not able to communicate.	DB stop	Available		
A.F10	Power Line Open Phase	One phase is not connected in the main power supply.	DB stop	Available		
CPF00	Digital Operator Transmission Error	Digital Operator fails to communicate with SERVOPACK.	–	N/A		Not decided
CPF01			–	N/A		
A. – –	Not an error	Normal operation status	–	–		L

9.1.2 Warning Displays

The relation between warning displays and warning code outputs are shown in Table 9.2.

Table 9.2 Warning Displays and Outputs

Warning Display	Warning Name	Meaning
A.900	Position Error Pulse Overflow	Position error pulse exceeded the parameter settings (Pn520).
A.910	Overload	This warning occurs before the overload alarms (A.710 or A.720) occur. If the warning is ignored and operation continues, an overload alarm may occur.
A.920	Regenerative Overload	This warning occurs before the regenerative overload alarm (A.320) occurs. If the warning is ignored and operation continues, a regenerative overload alarm may occur.
A.930	Absolute Encoder Battery Voltage Lowered	This warning occurs when the absolute encoder battery voltage is lowered. Continuing the operation in this status may cause an alarm.
A.940	Data Setting Warning	This warning occurs when data attempted to be set is invalid.
A.941	Power ON From OFF Requires Setting Validation	The change of the parameters can be validated only after turning the power ON from OFF.
A.94A	Address Warning	This warning occurs when an invalid parameter or register address is used.
A.94B	Data Range Warning	This warning occurs when data attempted to be set is out of the acceptable range.
A.94C	Data Execution Warning	Invalid data execution
A.94D	Data Size Warning	This warning occurs when data attempted to be set or get has incorrect data size.
A.950	Command Warning	This warning occurs when an invalid SynqNet command is executed.

9.1.3 Troubleshooting of Alarm and Warning

When an error occurs in SERVOPACKs, an alarm display such as A.□□ and CPF□□ or warning display such as A.9□□ appears on the panel operator. However, the display “A.--” is not an alarm. Refer to the following sections to identify the cause of an alarm and the action to be taken.

Contact your Yaskawa representative if the problem cannot be solved by the described corrective action.

(1) Alarm Display and Troubleshooting

Table 9.3 Alarm Display and Troubleshooting

Alarm Display	Alarm Name	Situation at Alarm Occurrence	Cause	Corrective Actions
A.020	Parameter Checksum Error (EEPROM data of SERVOPACK is incorrect.)	Occurred when the control power supply was turned ON.	The control power supply ranged from 30 VAC to 60 VAC.	Correct the power supply, and set Fn005 to initialize the parameter.
			The power supply was turned OFF while changing the parameter setting.	Set Fn005 to initialize the parameter, and input the parameter again.
			The number of times that parameters were written exceeded the limit. For example, the parameter was changed every scan through the host controller.	Replace the SERVOPACK. (Reconsider the parameter writing method.)
			SERVOPACK EEPROM and the related circuit are faulty.	Replace the SERVOPACK.
A.021	Parameter Format Error (The data of the parameter is incorrect)	Occurred when the power was turned back ON after parameters are copied with parameter copy function of the digital operator.	The model number of the SERVOPACK in the software being used is old and is not compatible with current parameters.	Replace the SERVOPACK Change the parameter settings to be compatible with the model number in the software being used.
A.022	System Checksum Error (The data of the parameter is incorrect)	Occurred when the control power supply was turned ON.	The control power supply ranged from 30 VAC to 60 VAC.	Correct the power supply, and set Fn005 to initialize the parameter.
			The power supply was turned OFF while changing the parameter setting.	Set Fn005 to initialize the parameter, and input the parameter again.
			SERVOPACK EEPROM and related circuit are faulty.	Replace the SERVOPACK.
A.023	Parameter Password Error (The data of the parameter is incorrect)	Occurred when the control power supply was turned ON.	A SERVOPACK board fault occurred.	Replace the SERVOPACK.
A.030	Main Circuit Detector Error	Occurred when the control power supply was turned ON or during operation.	A SERVOPACK fault occurred.	Replace the SERVOPACK.
A.040	Parameter Setting Error (The parameter setting out of the allowable setting range)	Occurred when the control power supply was turned ON.	The SERVOPACK and servomotor capacities do not match each other.	Select a proper combination of SERVOPACK and servomotor capacities.
			The SERVOPACK EEPROM and the related circuit are faulty.	Replace the SERVOPACK.
A.042	Combination of parameters out of setting range	Occurred after having changed the setting of Pn533 “Program JOG Movement Speed.”	The speed set for Fn004 “Program JOG Operation” is below the allowable range because of the change in Pn533 “program JOG movement speed.”	Increase the setting for Pn533 “Program JOG Movement Speed.”

Table 9.3 Alarm Display and Troubleshooting (Cont'd)

Alarm Display	Alarm Name	Situation at Alarm Occurrence	Cause	Corrective Actions
A.050	Combination Error (SERVOPACK and servomotor capacities do not match each other.)	Occurred when the control power supply was turned ON.	SERVOPACK and servomotor capacities do not match each other. servomotor capacity / SERVOPACK capacity \leq 1/4 or servomotor capacity / SERVOPACK capacity \geq 4	Select a proper combination of SERVOPACK and servomotor capacities.
			The parameter written in the encoder is incorrect.	Replace the servomotor (encoder).
			A SERVOPACK board fault occurred.	Replace the SERVOPACK.
A.051	Unsupported Product Alarm	Occurred when the control power supply was turned ON.	The serial converter unit unsupported was connected.	Check and then correct the wiring.
A.0b0	Servo ON Reference Invalid Alarm	Occurred when the servo was ON after having used the following functions. JOG operation (Fn002), origin search (Fn003), program JOG operation (Fn004), EasyFFT(Fn019)	The servo ON reference was input just when occurring the servo ON reference invalid error.	Turn OFF the control power supply and then turn them ON again.

Table 9.3 Alarm Display and Troubleshooting (Cont'd)

Alarm Display	Alarm Name	Situation at Alarm Occurrence	Cause	Corrective Actions	
A.100	Overcurrent (An overcurrent flowed through the IGBT) or Heat Sink Overheated (Heat sink of SERVOPACK was overheated.)	Occurred when the control power supply was turned ON.	The overload alarm has been reset by turning OFF the power too many times.	Change the alarm resetting method.	
			The connection between SERVOPACK board and thermostat switch is incorrect.	Replace the SERVOPACK.	
			A SERVOPACK board fault occurred.	Replace the SERVOPACK.	
		Occurred when the main circuit power supply was turned ON or an overcurrent occurred while the servomotor was running.	The connection between grounding and U, V, or W is incorrect.	Check the wiring and connect correctly.	
			The grounding line has contact with other terminals.	Check the wiring and connect correctly.	
			A short-circuit occurred between U, V and W of the servomotor cable and the grounding.	Repair or replace the servomotor cable.	
			A short-circuit of phase U, V, and W of the servomotor cable occurred.	Repair or replace the servomotor cable.	
			The wiring of regenerative resistor is incorrect.	Check the wiring and connect correctly.	
			A short-circuit between U, V and W of the SERVOPACK and the grounding occurred.	Replace the SERVOPACK.	
			A SERVOPACK fault occurred (current feedback circuit, power transistor or board fault).	Replace the SERVOPACK.	
			A short-circuit between U, V and W of the servomotor and the grounding occurred.	Replace the servomotor.	
			A short-circuit of phase U, V, and W of the servomotor occurred.	Replace the servomotor.	
			A fault occurred in the dynamic brake circuit.	Replace the SERVOPACK, and reduce the load, or reduce the number of rotations used.	
			Frequent activation of dynamic brake (occurrence of DB overload alarm)	Replace the SERVOPACK, and reduce the DB operation frequency.	
			The overload alarm has been reset by turning OFF the power too many times.	Change the alarm resetting method.	
			Overload or regenerative power exceeds the regenerative resistor capacity.	Reconsider the load and operation conditions.	
			Incorrect mounting of SERVOPACK (direction, distance to other devices) Heat radiation of the panel or heat around the panel.	The ambient temperature for SERVOPACK must be 55 °C or less.	
			A SERVOPACK fan fault occurred.	Replace the SERVOPACK.	
A SERVOPACK fault occurred.	Replace the SERVOPACK.				
A.300	Regeneration Error Detected (Detected when the power to the main circuit was turned ON)	Occurred when the control power supply was turned ON	A SERVOPACK board fault occurred.	Replace the SERVOPACK.	
			Occurred when the main circuit power supply was turned ON.	Pn600 is set to a value other than "0" for servomotor 400 W or less, and an external regenerative resistor is not connected.	Connect an external regenerative resistor, or set Pn600 to "0" if an external regenerative resistor is not connected.
				Check for wrong wiring or disconnection of regenerative resistor.	Correct the wiring for the external regenerative resistor.
		A SERVOPACK fault occurred (such as regenerative transistor and voltage sensor fault).		Replace the SERVOPACK.	
		Occurred during normal operation.	Check for wrong wiring and disconnection of regenerative resistor.	Correct the wiring for the external regenerative resistor.	
			The jumper between B2 and B3 is removed for the servomotor 500 W or more.	Correct the wiring.	
			Regenerative resistor is disconnected, so the regenerative energy became excessive.	Replace the regenerative resistor or replace the SERVOPACK. Reconsider the load and operation conditions.	
			A SERVOPACK fault, such as regenerative transistor and voltage sensor fault, occurred.	Replace the SERVOPACK.	

Table 9.3 Alarm Display and Troubleshooting (Cont'd)

Alarm Display	Alarm Name	Situation at Alarm Occurrence	Cause	Corrective Actions
A.320	Regenerative Overload (Detected when the power to the main circuit was turned ON)	Occurred when the control power supply was turned ON.	A SERVOPACK board fault occurred.	Replace the SERVOPACK.
		Occurred when the main circuit power supply was turned ON	The power supply voltage is 270 V or more.	Correct the input voltage.
		Occurred during normal operation. (large increase of regenerative resistor temperature)	The regenerative energy is excessive.	Select a proper regenerative resistance capacity, or reconsider the load and operation conditions.
			The regenerating state continued.	
		Occurred during normal operation. (small increase of regenerative resistor temperature)	The set value of parameter Pn600 is smaller than the external regenerative resistor capacity.	Correct the set value of parameter Pn600.
			A SERVOPACK fault occurred.	Replace the SERVOPACK.
Occurred at servomotor deceleration.	The regenerative energy is excessive.	Select a proper regenerative resistance capacity, or reconsider the load and operation conditions.		
A.330	Main Circuit Wiring Error (Detected when the power to the main circuit was turned ON)	Occurred when the control power supply was turned ON.	A SERVOPACK board fault occurred.	Replace the SERVOPACK.
		Occurred when the main circuit power supply was turned ON.	In DC power input mode, AC power is supplied through L1 and L2 or L1, L2, and L3.	For AC power input, set Pn001.2=0. For DC power input, set Pn001.2=1.
			In AC power input mode, DC power is supplied through B1/⊕ and ⊖ terminals.	
		Pn600 is set to 0 if regenerative resistance is disconnected.	Set Pn600 to 0.	
A.400	Overvoltage (Detected when the SERVOPACK main circuit DC voltage is approx. 410 V or more) (Detected when the power to the main circuit was turned ON)	Occurred when the control power supply was turned ON.	A SERVOPACK board fault occurred.	Replace the SERVOPACK.
		Occurred when the main circuit power supply was turned ON.	The AC power voltage is 290 V or more.	AC power voltage must be within the specified range.
			A SERVOPACK fault occurred.	Replace the SERVOPACK.
		Occurred during normal operation.	Check the AC power voltage (no excessive voltage change?)	AC power voltage must be within the specified range.
			High motor speed and excessive load moment of inertia (insufficient regenerative capacity)	Reconsider the load and operation conditions (check the load moment of inertia and minus load specifications.)
			A SERVOPACK fault occurred.	Replace the SERVOPACK.
		Occurred at servomotor deceleration.	High motor speed and excessive load moment of inertia	Reconsider the load and operation conditions.

Table 9.3 Alarm Display and Troubleshooting (Cont'd)

Alarm Display	Alarm Name	Situation at Alarm Occurrence	Cause	Corrective Actions
A.410	Undervoltage (Detected when the SERVOPACK main circuit DC voltage is approx. 170 V or less.) (Detected when the power to the main circuit was turned ON)	Occurred when the control power supply was turned ON.	A SERVOPACK board fault occurred.	Replace the SERVOPACK.
		Occurred when the main circuit power supply was turned ON.	The AC power supply voltage is 120 V or less.	AC power supply voltage must be within the specified range.
			The fuse of the SERVOPACK is blown out.	Replace the SERVOPACK.
			Inrush current limit resistor disconnection (abnormal power supply voltage? inrush current limit resistor overload?)	Replace the SERVOPACK (check the power supply voltage, and reduce the number of times of main circuit ON/OFF operation.)
			A SERVOPACK fault occurred.	Replace the SERVOPACK.
		Occurred during normal operation.	Lowered AC power supply voltage (large voltage drop?)	AC power supply voltage must be within the specified range.
			A temporary power failure occurred.	Reset the alarm and restart the operation.
			The servomotor cable is short-circuited.	Repair or replace the servomotor cable.
			The servomotor is short-circuited.	Replace the servomotor.
			A SERVOPACK fault occurred.	Replace the SERVOPACK.
A.510	Overspeed (Detected when the feedback speed is the maximum motor speed \times 1.1 or more.)	Occurred when the control power supply was turned ON	A SERVOPACK board fault occurred.	Replace the SERVOPACK.
		Occurred in servo ON status.	Incorrect order of phases U, V, and W in the servomotor wiring.	Correct the servomotor wiring.
			The encoder wiring is incorrect.	Correct the encoder wiring.
			Malfunction due to noise interference in the encoder wiring	Take measures against noise for the encoder wiring.
			A SERVOPACK fault occurred.	Replace the SERVOPACK.
		Occurred when the servomotor started running or at high speed run.	Incorrect order of phases U, V, and W in the servomotor wiring.	Correct the servomotor wiring.
			The encoder wiring is incorrect.	Correct the encoder wiring.
			Malfunction occurred due to noise interference in the encoder wiring	Take measures against noise for the encoder wiring.
			The position/speed reference input is too large.	Reduce the reference value.
			The setting of reference input gain is incorrect.	Correct the reference input gain setting.
A SERVOPACK board fault occurred.	Replace the SERVOPACK.			
A.710	Overload: High Load	Occurred when the control power supply was turned ON.	A SERVOPACK board fault occurred.	Replace the SERVOPACK.
		Occurred when the servo was turned ON.	Faulty servomotor wiring (faulty wiring and connection)	Correct the servomotor wiring.
A.720	Overload: Low Load	Occurred when the servo was turned ON.	Faulty encoder wiring (faulty wiring and connection)	Correct the encoder wiring.
			A SERVOPACK fault occurred.	Replace the SERVOPACK.
		Occurred when the servomotor did not run by the reference input.	Faulty servomotor wiring (faulty wiring and connection)	Correct the servomotor wiring.
			Faulty encoder wiring (faulty wiring and connection)	Correct the encoder wiring.
			The starting torque exceeds the maximum torque.	Reconsider the load and operation conditions, or reconsider the servomotor capacity.
			A SERVOPACK fault occurred.	Replace the SERVOPACK.
		Occurred during normal operation.	The effective torque exceeds the rated torque, or the starting torque largely exceeds the rated torque.	Reconsider the load and operation conditions, or reconsider the servomotor capacity.
			A SERVOPACK fault occurred.	Replace the SERVOPACK.

9.1.3 Troubleshooting of Alarm and Warning

Table 9.3 Alarm Display and Troubleshooting (Cont'd)

Alarm Display	Alarm Name	Situation at Alarm Occurrence	Cause	Corrective Actions
A.730	Dynamic Brake Overload (For SERVOPACKs 500 W to 1.0 kW)	Occurred when the control power supply was turned ON.	A SERVOPACK board fault occurred.	Replace the SERVOPACK.
		Occurred when the servomotor was running and in the status other than servo OFF.	A SERVOPACK board fault occurred.	Replace the SERVOPACK.
		Occurred when the servomotor was running in servo OFF status.	The rotating energy at DB stop exceeds the DB resistance capacity.	①Reduce the motor speed. ②Reduce the load moment of inertia. ③Reduce the number of times of DB stop operation.
			A SERVOPACK fault occurred.	Replace the SERVOPACK.
A.740	Overload of Surge Current Limit Resistor (Detected when the number of times of the main circuit power ON/OFF operation exceeds 10 times/2 seconds.)	Occurred when the control power supply was turned ON.	A SERVOPACK board fault occurred.	Replace the SERVOPACK.
		Occurred during operations other than the main circuit ON/OFF.	A SERVOPACK board fault occurred.	Replace the SERVOPACK.
		Occurred at the main circuit power supply is ON/OFF operation.	The inrush current limit resistor operation frequency at the main circuit power supply ON/OFF operation exceeds the allowable range.	Reduce the main circuit power supply ON/OFF operation frequency to five times/min. or less.
			A SERVOPACK fault occurred.	Replace the SERVOPACK.
A.7A0	Heat Sink Overheated (Detected when the heat sink temperature exceeds 100 °C.)	Occurred when the control power supply was turned ON	A SERVOPACK fault occurred.	Replace the SERVOPACK.
			The overload alarm has been reset by turning OFF the power too many times.	Change the alarm resetting method.
		Occurred when the main circuit power supply was turned ON or while the servomotor was running.	The load exceeds the rated load.	Reconsider the load and operation conditions, or reconsider the servomotor capacity.
			The SERVOPACK ambient temperature exceeds 55°C.	The ambient temperature must be 55°C or less.
			A SERVOPACK fault occurred.	Replace the SERVOPACK.
			The overload alarm has been reset by turning OFF the power too many times.	Change the alarm resetting method.
			Faulty connection of SERVOPACK board and thermostat switch	Replace the SERVOPACK.
			The overload or the regenerative energy exceeds the resistor capacity.	Reconsider the load and operation conditions.
			Incorrect mounting of SERVOPACK (direction and distance to the peripheral devices) Heat radiation from the panel or heat around the SERVOPACK.)	The ambient temperature for SERVOPACK must be 55 °C or less.
			A SERVOPACK fan fault occurred.	Replace the SERVOPACK.

Table 9.3 Alarm Display and Troubleshooting (Cont'd)

Alarm Display	Alarm Name	Situation at Alarm Occurrence	Cause	Corrective Actions
A.810	Encoder Backup Error (Detected on the encoder side) (Only when an absolute encoder is connected.)	Occurred when the control power supply was turned ON (Setting: Pn002.2=1)	A SERVOPACK board fault occurred. (when an absolute encoder is used with the setting for incremental encoder.)	Replace the SERVOPACK.
		Occurred when the control power supply was turned ON (Setting: Pn002.2=0), using an absolute encoder	Initial power ON to the absolute encoder	Conduct the encoder setup operation.
			The encoder cable had been removed once.	Make sure of the connection and conduct the encoder setup operation.
			Both PG power supply (+5 V) and battery power supply from the SERVOPACK are broken down.	Repair the power supply to the encoder (replace battery, etc.), and conduct the encoder setup operation.
			An Absolute encoder fault occurred.	If the alarm cannot be reset by re-setup operation, replace the encoder.
	SERVOPACK fault	Replace the SERVOPACK.		
A.820	Encoder Checksum Error (Detected on the encoder side.)	Occurred when the control power supply was turned ON or during operation	An Encoder fault occurred. (encoder self-diagnosis)	Setup the encoder. If this alarm occurs frequently, replace the servomotor.
			A SERVOPACK fault occurred.	Replace the SERVOPACK.
		Occurred when SEN signal was turned ON.	An Encoder fault occurred. (encoder self-diagnosis)	Setup the encoder. If this alarm occurs frequently, replace the servomotor.
A.830	Absolute Encoder Battery Error Detected when the battery voltage is lower than the specified value 2 to 4 seconds after the control power supply turns ON.) (Only when an absolute encoder is connected)	When the control power supply was turned ON (Setting: Pn002.2=1)	A SERVOPACK board fault occurred. (when the absolute encoder is used as an incremental)	Replace the SERVOPACK.
		When the control power supply was turned ON (Setting: Pn002.2=0), using an absolute encoder.	The battery connection is incorrect.	Connect correctly the battery.
			The battery voltage is lower than the specified value 2.7 V.	Replace the battery, and then turn ON the power to the encoder.
			A SERVOPACK board fault occurred.	Replace the SERVOPACK.
A.840	Encoder Data Error (Detected on the encoder side)	Occurred when the control power supply was turned ON.	A malfunction occurred in the encoder.	Turn OFF the encoder power supply and on again. If this alarm occurs frequently, replace the servomotor.
			A SERVOPACK board fault occurred.	Replace the SERVOPACK.
		Occurred during operation.	A malfunction occurred in the encoder.	Correct the wirings around the encoder (separate the encoder cable from the power line, grounding, etc.)
			An Encoder fault occurred.	Turn OFF the encoder power supply and ON again. If this alarm occurs frequently, replace the servomotor.
			A SERVOPACK board fault occurred.	Replace the SERVOPACK.
A.850	Encoder Over-speed (Detected when the encoder power supply turns ON.) (Detected on the encoder side.)	Occurred when the control power supply was turned ON.	When the encoder power supply turns ON, the servomotor runs at 200 min ⁻¹ or more.	Turn ON the encoder power supply when the servomotor runs at the speed less than 200 min ⁻¹ .
			An Encoder fault occurred.	Replace the servomotor.
			A SERVOPACK board fault occurred.	Replace the SERVOPACK.
		Occurred during operation.	An Encoder fault occurred.	Replace the servomotor.
			A SERVOPACK board fault occurred.	Replace the SERVOPACK.

Table 9.3 Alarm Display and Troubleshooting (Cont'd)

Alarm Display	Alarm Name	Situation at Alarm Occurrence	Cause	Corrective Actions
A.860	Encoder Overheated (Only when an absolute encoder is connected) (Detected on the encoder side.)	Occurred when the control power supply was turned ON.	An Encoder fault occurred.	Replace the servomotor.
			A SERVOPACK board fault occurred.	Replace the SERVOPACK.
		Occurred during operation.	The ambient temperature at servomotor is too high.	The ambient temperature must be 40°C or less.
			The servomotor load is more than the rated load.	The servomotor load must be within the specified range.
		An Encoder fault occurred.	Replace the servomotor.	
		A SERVOPACK board fault occurred.	Replace the SERVOPACK.	
A.b31	Current Detection Error 1	Occurred when the control power supply was turned ON or during operation.	Phase-U current detection circuit fault	Replace the SERVOPACK.
A.b32	Current Detection Error 2		Phase-V current detection circuit fault	
A.b33	Current Detection Error 3		Power supply detection circuit fault	Replace the SERVOPACK.
			Servomotor cable disconnection	Check the motor wiring.
A.bF0	System Alarm 0 (Internal program processing error)	Occurred when the control power supply was turned ON.	A SERVOPACK board fault occurred.	Replace the SERVOPACK.
A.bF1	System Alarm 1 (Internal program error)			
A.bF2	System Alarm 2 (Current control processing program error)			
A.bF3	System alarm 3 (Encoder interface processing error)			
A.bF4	System Alarm 4 (CPU watchdog timer error)			
A.C10	Servo Overrun Detected (Detected when the servo is ON.)	Occurred when the control power supply was turned ON.	A SERVOPACK board fault occurred.	Replace the SERVOPACK.
		Occurred when the servo was ON or a reference was input.	Incorrect order of phase-U, -V, and -W in the servomotor wiring.	Correct the servomotor wiring.
			An Encoder fault occurred.	Replace the servomotor.
		A SERVOPACK fault occurred.	Replace the SERVOPACK.	
A.C80	Absolute Encoder Clear Error and Multi-turn Limit Setting Error	Occurred when the control power supply was turned ON	An Encoder fault occurred.	Replace the servomotor.
			A SERVOPACK board fault occurred.	Replace the SERVOPACK.
		Occurred when an encoder alarm was reset	An Encoder fault occurred.	Replace the servomotor.
			A SERVOPACK board fault occurred.	Replace the SERVOPACK.

Table 9.3 Alarm Display and Troubleshooting (Cont'd)

Alarm Display	Alarm Name	Situation at Alarm Occurrence	Cause	Corrective Actions
A.C90	Encoder Communications Error	Occurred when the control power supply was turned ON or during operation	Incorrect encoder wiring and faulty contact	Correct the encoder wiring.
			Noise interference due to improper encoder cable specifications	Use tinned annealed copper twisted-pair wire or twisted-pair shielded wire, wire with a core at least 0.12 mm ² (0.0002 in ²).
			Noise interference because the encoder cable length is too long.	The maximum allowable wiring cable is 20 m (65.6 ft).
A.C91	Encoder Communications Position Data Error		Noise interference on the signal line because the encoder cable is bent and the sheath is damaged.	Correct the encoder cable layout.
			The encoder cable is bundled with a high-current line or near a high-current line.	Correct the encoder cable layout so that no surge is applied.
			FG varies because of the influence from the servomotor side machines such as welder.	Make the grounding for the machine separately from PG side FG.
A.C92	Encoder Communications Timer Error		Noise interference on the signal line from the encoder	Take proper measures prevent noise sources from coming within close contact of the encoder wiring.
			Excessive vibration and shocks to the encoder	Reduce the machine vibration or mount the servomotor securely.
			An Encoder fault occurred.	Replace the servomotor.
			A SERVOPACK board fault occurred.	Replace the SERVOPACK
A.CA0	Encoder Parameter Error	Occurred when the control power supply was turned ON	An Encoder fault occurred.	Replace the servomotor.
			A SERVOPACK board fault occurred.	Replace the SERVOPACK.
A.Cb0	Encoder Echoback Error	Occurred when the control power supply was turned ON or during operation	Encoder incorrect wiring and faulty contact	Correct the encoder wiring.
			Noise interference due to improper encoder cable specifications	Use tinned annealed copper twisted-pair wire or twisted-pair shielded wire, wire with a core at least 0.12 mm ² (0.0002 in ²).
			Noise interference because the encoder cable length is too long.	The maximum allowable wiring cable is 20 m (65.6 ft).
			Noise interference on the signal line because the encoder cable is bent and the sheath is damaged.	Correct the encoder cable layout.
			The encoder cable is bundled with a high-current line or near a high-current line.	Correct the encoder cable layout so that no surge is applied.
			FG varies because of the influence from the servomotor side machines such as welder.	Ground the machine separately from PG side FG.
			Noise interference on the signal line from the encoder	Take measures against noise for the encoder wiring.
			Excessive vibration and shocks to the encoder	Reduce the machine vibration or mount the servomotor securely.
			An Encoder fault occurred.	Replace the servomotor.
A.CC0	Multi-turn Limit Disagreement	Occurred when the control power supply was turned ON	Incorrect setting of parameters for the SERVOPACK	Correct the setting of Pn205 (0 to 65535).
			The multiturn limit value for the encoder is not set or changed.	Execute Fn013 at the occurrence of alarm.
		Occurred during operation	A SERVOPACK board fault occurred.	Replace the SERVOPACK.

Table 9.3 Alarm Display and Troubleshooting (Cont'd)

Alarm Display	Alarm Name	Situation at Alarm Occurrence	Cause	Corrective Actions
A.d00	Position Error Pulse Overflow (In servo ON status, the position error pulses exceed the overflow level set in the parameter Pn520.)	Occurred when the control power supply was turned ON.	A SERVOPACK board fault occurred.	Replace the SERVOPACK.
		Occurred at the servomotor high-speed operation.	Faulty contact in the servomotor U, V, and W wirings	Correct the servomotor wiring.
			A SERVOPACK board fault occurred.	Replace the SERVOPACK.
		The servomotor did not run with position reference input.	Incorrect wirings of the servomotor U, V, and W.	Correct the servomotor wiring.
			A SERVOPACK board fault occurred.	Replace the SERVOPACK.
		Normal movement, but occurred with a long distance reference input.	Improper SERVOPACK gain adjustment	Increase the speed loop gain (Pn100) and position loop gain (Pn102).
			The position reference pulse frequency is too high.	Reduce slowly the position reference pulse frequency.
			Improper setting of the parameter Pn520 (Position Error Pulse Overflow Alarm Level)	Set the parameter Pn520 to proper value.
	The servomotor specifications do not meet the load conditions such as torque and moment of inertia.	Reconsider and correct the load and servomotor capacity.		
A.E02	I/F Alarm 2	Occurred when the SynqNet communications was OFF.	This is not an alarm.	Turn ON the SynqNet communication power supply.
		Occurred when the module reset.	This is not an alarm.	—
		Occurred during operation.	A SERVOPACK board fault occurred.	Replace the SERVOPACK.
A.E0A	FPGA WDC Error	Occurred when the control power supply was turned ON.	FPGA WDC malfunction.	Replace the SERVOPACK.
A.E60	SynqNet Communication Error	Occurred when the control power supply was turned ON.	SynqNet and SERVOPACK are not able to communicate due to network communication error.	Reset network, and check for noise generators.
A.F10	Power Line Open Phase (In the main power supply ON status, the voltage stays low for one second or more at one of the phases R, S, and T.) (Detected when the main circuit power supply turns ON.)	Occurred when the control power supply was turned ON.	A SERVOPACK fault occurred.	Replace the SERVOPACK.
		Occurred when the main circuit power supply was turned ON.	Incorrect three-phase power supply wiring	Correct the power supply wiring.
			Unbalanced three-phase power supply	Balance the power supply by changing phases.
		Occurred when the servomotor was running.	A SERVOPACK fault occurred.	Replace the SERVOPACK.
			Faulty contact in three-phase power supply wiring	Correct the power supply wiring.
		Unbalanced three-phase power supply	Balance the power supply	
A SERVOPACK fault occurred.	Replace the SERVOPACK.			
CPF00	Digital Operator Transmission Error 1	Occurred when the power supply was turned ON with digital operator connected or when connecting digital operator with the power supply ON.	The contact between digital operator and SERVOPACK is faulty.	Insert securely the connector, or replace the cable.
			The external noise interference occurred to the digital operator or cable is faulty.	Move cable away from noise sources.
CPF01	Digital Operator Transmission Error 2		A Digital operator fault occurred.	Replace the digital operator.
			A SERVOPACK fault occurred.	Replace the SERVOPACK.

(2) Warning Display and Troubleshooting

Table 9.4 Warning Display and Troubleshooting

Warning Display	Warning Name	Situation at Warning Occurrence	Cause	Corrective Actions
A.900	Position Error Pulse Overflow	Occurred during operation.	A SERVOPACK board fault occurred.	Replace the SERVOPACK.
			Wiring is incorrect or the contact of servomotor U, V, and W is faulty.	Correct the servomotor wiring. Correct the encoder wiring.
			The SERVOPACK gain adjustment is improper.	Increase the speed loop gain (Pn100) and position loop gain (Pn102).
			The position reference pulse frequency is too high.	Decrease slowly the position reference pulse frequency. Apply the smoothing function. Adjust the electronic gear ratio.
			Setting of the parameter Pn520 (Position Error Pulse Alarm Level) is improper.	Set the parameter Pn520 to a value other than "0".
			The servomotor specifications do not meet the load conditions (torque, moment of inertia).	Reconsider and correct the load and servomotor capacity.
			A.910	Overload Warning for the alarms A.710 and A.720 In either of the following cases: 1. 20% of the overload detection level of A.710 2. 20% of the overload detection level of A.720.
Incorrect wiring and faulty contact in encoder wiring	Correct the encoder wiring.			
A SERVOPACK fault occurred.	Replace the SERVOPACK.			
The servomotor did not run with a reference input.	Incorrect wiring and faulty contact in servomotor wiring	Correct the servomotor wiring.		
	Incorrect wiring and faulty contact in encoder wiring	Correct the encoder wiring.		
	The starting torque exceeds the maximum torque.	Reconsider the load and operation conditions. Or, check the servomotor capacity.		
	A SERVOPACK fault occurred.	Replace the SERVOPACK.		
Occurred during operation.	The effective torque exceeds the rated torque.	Reconsider the load and operation conditions. Or, check the servomotor capacity.		
	Temperature in the SERVOPACK panel is high.	Reduce the in-panel temperature to 55°C or less.		
	A SERVOPACK fault occurred.	Replace the SERVOPACK.		
A.920	Regenerative Overload	Occurred when the control power supply was turned ON.	A SERVOPACK board fault occurred.	Replace the SERVOPACK.
	Warning for the alarm A.320	Occurred during normal operation. (Large increase of regenerative resistor temperature)	Regenerative energy is excessive.	Check the regenerative resistor capacity, or reconsider the load and operation conditions.
			Regenerative status continues.	
		Occurred during normal operation. (Small increase of regenerative resistor temperature)	The setting of parameter Pn600 is smaller than the external regenerative resistor capacity.	Correct the setting of parameter Pn600.
	A SERVOPACK fault occurred.		Replace the SERVOPACK.	
Occurred at servomotor deceleration.	Regenerative energy is excessive.	Check the regenerative resistor capacity, or reconsider the load and operation conditions.		

Table 9.4 Warning Display and Troubleshooting (Cont'd)

Warning Display	Warning Name	Situation at Warning Occurrence	Cause	Corrective Actions
A.930	Absolute Encoder Battery Error (The battery voltage stays below the specified value four seconds after the control power supply was turned ON.) (Only when an absolute encoder is connected.)	Occurred when the control power supply was turned ON. (Setting: Pn002.2=1)	A SERVOPACK board fault occurred. (The absolute encoder is used in the incremental encoder setting.)	Replace the SERVOPACK.
		Occurred four seconds or more after the control power supply was turned ON. (Setting: Pn002.2=0) When an absolute encoder was used	Incorrect or faulty connection of battery	Correct the battery connection.
			The battery voltage is lower than the specified value 2.7 V.	Replace the battery, and turn OFF the encoder power supply and ON again.
			A SERVOPACK board fault occurred.	Replace the SERVOPACK.
A.940	Data Setting Warning	Occurred after parameter setting.	Invalid data is attempted to be set.	Verify data used
A.941	Power ON from OFF after Parameter Change	Occurred after parameter setting.	To validate new setting of this parameter, turn OFF the power and ON again.	Turn OFF the power and ON again.
A.94A	Parameter /Register Address Warning	Occurred after parameter setting.	This warning occurs when an invalid parameter or register address is used.	Verify address used
A.94B	Data Range Warning	Occurred after parameter setting.	This warning occurs when data attempted to be set is out of the acceptable range.	Verify used data is within allowable range.
A.94C	Operation Warning	Occurred after operation of parameter setting.	Operation or data processing execution causes a warning.	Reconsider operation procedure and operation conditions.
A.94D	Data Size Warning	Occurred after parameter set or get.	This warning occurs when data attempted to be set or get has incorrect data size.	Verify data size used
A.950	Command Warning	Occurred after a command is issued.	This warning occurs when an invalid SynqNet command is executed.	Verify command

9.1.4 Troubleshooting for Malfunction without Alarm Display

The troubleshooting for the malfunctions that causes no alarm display is listed below.

Contact your Yaskawa representative if the problem cannot be solved by the described corrective actions.

Table 9.5 Troubleshooting for Malfunction without Alarm Display

Symptom	Cause	Inspection	Corrective Actions
		■: Turn OFF the servo system before executing operations.	
Servomotor Does Not Start	The control power supply is not ON.	Check voltage between power supply terminals.	Correct the power circuit.
	The main circuit power supply is not ON.	Check the voltage between power supply terminals.	Correct the power circuit.
	Wrong wiring or disconnection of I/O signal connector CN1	Check if the connector CN1 is properly inserted and connected.	Correct the connector CN1 connection.
	Servomotor or encoder wiring disconnected.	Check the wiring.	Correct the wiring.
	Overloaded	Run under no load.	Reduce load or replace with larger capacity servomotor.
	Encoder type differs from parameter setting.	Check incremental or absolute encoder.	Set parameter Pn002.2 to the encoder type being used.
	P-OT or N-OT input signal stays OFF.	Check the Overtravel Input signal.	Turn ON the Overtravel Input signal.
	A SERVOPACK fault occurred.	A SERVOPACK board fault occurred.	Replace the SERVOPACK.
Servomotor Moves Instantaneously, then Stops	Incorrect servomotor wiring	Check the servomotor wiring.	Correct the servomotor wiring.
	Incorrect encoder wiring	Check the encoder wiring.	Correct the encoder wiring.
Servomotor Speed Unstable	Wiring connection to motor defective	Check connection of power lead (phases-U, -V, and -W) and encoder connectors.	Tighten any loose terminals or connectors.
Servomotor Rotates Without Reference Input	A SERVOPACK fault occurred.	A SERVOPACK board fault occurred.	Replace the SERVOPACK.
Dynamic Brake (DB) Does Not Operate	Incorrect parameter setting	Check the setting of parameter Pn001.0.	Correct the parameter setting.
	DB resistor was disconnected	Excessive moment of inertia, motor overspeed, DB frequently activated?	Replace the SERVOPACK, and reconsider the load.
	DB drive circuit is faulty.	DB circuit parts are faulty.	Replace the SERVOPACK.

9.1.4 Troubleshooting for Malfunction without Alarm Display

Table 9.5 Troubleshooting for Malfunction without Alarm Display (Cont'd)

Symptom	Cause	Inspection	Corrective Actions
		■: Turn OFF the servo system before executing operations.	
Abnormal Noise from servomotor	Mounting not secured	Check for any loose mounting screws.	Tighten the mounting screws.
		Check for misalignment of couplings.	Align the couplings.
		Check for unbalanced couplings.	Balance the couplings.
	Defective bearings	Check for noise and vibration around the bearings.	If any abnormalities, contact your Yaskawa representative.
	Vibration source on the driven machine.	Any foreign matter, damages, or deformation on the machine movable section.	Contact the machine manufacturer.
	Noise interference due to incorrect input signal wire specifications.	The specifications of input signal wires must be: Tinned annealed copper twisted-pair or twisted-pair shielded wires with core 0.12 mm ² (0.0002 in ²) min..	Use the specified input signal wires.
	Noise interference due to long length of input signal line	The maximum allowable cable length is 3 m (9.84 ft) and the impedance a few hundreds ohm max.	Shorten the wiring distance for input signal line to the specified range.
	Noise interference due to incorrect encoder cable specifications.	The specifications of encoder cable must be: Tinned annealed copper twisted-pair or twisted-pair shielded wires with core 0.12 mm ² (0.0002 in ²) min.	Use the specified encoder cable.
	Noise interference due to long encoder cable wiring	The maximum allowable cable length is 20 m (65.6 ft).	Shorten the encoder cable wiring distance to the specified value.
	Noise due to damaged encoder cable	Check if the encoder cable is not damaged or bent.	Modify the encoder cable layout.
	Excessive noise to the encoder cable	Check if the encoder cable is bundled with high-current line or near the high-current line.	Install a surge suppressor to the encoder cable.
	FG varies by influence of machines such as welder on the servomotor side	Check if the machine is correctly grounded.	Ground the machine separately from PG side FG.
	SERVOPACK pulse counting error due to noise	Check if there is noise interference on the signal line from encoder.	Take measure against noise for the encoder wiring.
	Excessive vibration and shock to the encoder	Vibration from the machine or servomotor incorrect installation	Reduce vibration from the machine, or secure the servomotor installation.
Encoder fault	Encoder fault	Replace the motor.	
Servomotor Vibrates at Approximately 200 to 400 Hz.	Speed loop gain value (Pn100) too high.	Factory setting: Kv=40.0 Hz Refer to the gain adjustment in User's Manual.	Reduce speed loop gain (Pn100) preset value.
	Position loop gain value (Pn102) too high	Factory setting: Kp=40.0/s Refer to the gain adjustment in User's Manual.	Reduce position loop gain (Pn102) preset value.
	Incorrect speed loop integral time constant Pn101 setting	Factory setting: Ti=20.00 ms Refer to the gain adjustment in User's Manual.	Correct the speed loop integral time constant Pn101 setting.
	Incorrect moment of inertia ratio data Pn103	Check the moment of inertia ratio data Pn103.	Correct the moment of inertia ratio data Pn103.

Table 9.5 Troubleshooting for Malfunction without Alarm Display (Cont'd)

Symptom	Cause	Inspection	Corrective Actions
		■: Turn OFF the servo system before executing operations.	
High Rotation Speed Overshoot on Starting and Stopping.	Speed loop gain value (Pn100) too high.	Factory setting: $K_v=40.0$ Hz, Refer to the gain adjustment in User's Manual.	Reduce the speed loop gain Pn100 preset value.
	Position loop gain value (Pn102) too high	Factory setting: $K_p=40.0/s$ Refer to the gain adjustment in User's Manual.	Reduce the position loop gain Pn102 preset value.
	Incorrect speed loop integral time constant Pn101 setting	Factory setting: $T_i=20.00$ ms Refer to the gain adjustment in User's Manual.	Correct the speed loop integral time constant Pn101 setting.
	Incorrect moment of inertia ratio data Pn103	Check the rotational moment of inertia ratio data Pn103.	Correct the rotational moment of inertia ratio data Pn103. Use the mode switch setting function.
ABS (absolute) Position Difference Error (The position saved in Host controller when the power turned OFF is different from the position when the power turned ON.)	Noise interference due to improper encoder cable specifications	The specifications of encoder cable must be: Tinned annealed copper twisted-pair or twisted-pair shielded wires with core 0.12 mm^2 (0.0002 in^2) min.	Use encoder cable with the specified specifications.
	Noise interference because the encoder cable distance is too long.	The maximum allowable cable length is 20 m (65.6 ft).	The encoder cable distance must be within the specified range.
	Noise interference due to damaged encoder cable	Noise interference to the signal line because the encoder cable is bent or damaged	Correct the encoder cable layout.
	Excessive noise to the encoder cable	Check if the encoder cable is bundled with a high-current line or near high-current line.	Change the encoder cable layout so that no surge is applied.
	FG affected by noise from machines such as welder installed on servomotor side	Check if the grounding for the machine is properly made.	Ground encoder to FG; do not share a ground with a machine.
	SERVOPACK pulse counting error due to noise interference	Check if the signal line from the encoder receives influence from noise interference.	Take measures against noise for encoder wiring.
	Excessive vibration and shock to the encoder	Vibration from machine or servomotor due to incorrect installation.	Reduce vibration from machine or mount securely the servomotor
	Encoder fault	Encoder fault (no change in pulse count)	Replace the servomotor.
	SERVOPACK fault	Check the multi-turn data from SERVOPACK.	Replace the SERVOPACK.
	Host controller multi-turn data reading error	Check for the error detection at the host controller.	Correct the error detection section of host controller.
Check if the host controller executes data parity check.		Execute the multi-turn data parity check.	
Check the noise on the signal line between SERVOPACK and the host controller.		Execute the multi-turn data parity check. Noises may influence when the parity check is not executed.	
Overtravel (OT) (Movement over the zone specified by the host controller)	An overtravel signal is output (P-OT (1CN-2) or N-OT (1CN-3) is at "H").	Check if the voltage of input signal external power supply (+24 V) is correct.	Connect to the external +24 V power supply.
		Check if the overtravel limit switch (SW) operates properly.	Correct the overtravel limit SW.
		Check if the overtravel limit switch (SW) is connected correctly.	Correct the overtravel limit SW wiring.
	The overtravel signal does not operate normally.	Input signal external power supply fluctuation	Stabilize the external +24 V power supply voltage.
		Check if the overtravel limit switch (SW) activate correctly.	Adjust the overtravel limit SW.
		Check if the overtravel limit switch wiring is correct.	Correct the overtravel limit SW wiring.

9.1.4 Troubleshooting for Malfunction without Alarm Display

Table 9.5 Troubleshooting for Malfunction without Alarm Display (Cont'd)

Symptom	Cause	Inspection	Corrective Actions
		■: Turn OFF the servo system before executing operations.	
Overtravel (OT) (Movement over the zone specified by the host controller)	Incorrect servomotor stop method selection	Check if “coast to stop” in servo OFF status is selected	Check Pn001.0 and Pn001.1.
		Check if “coast to stop” in torque control mode is selected	Check Pn001.0 and Pn001.1.
	Improper overtravel position setting	The distance to the position of OT (overtravel) is too short relative to coasting distance.	Correct the OT position.
	Noise interference due to improper encoder cable specifications	The encoder cable specifications must be: Tinned annealed copper twisted-pair or twisted-pair shielded wires with core 0.12 mm ² (0.0002 in ²) min.	Use encoder cable with the specified specifications.
	Noise interference because the encoder cable distance is too long.	The maximum allowable cable length is 20 m (65.6 ft).	The encoder cable distance must be within the specified range.
	Noise influence due to damaged encoder cable	Check if the encoder cable is bent or its sheath is damaged.	Correct the encoder cable layout.
	Excessive noise interference to encoder cable	Check if the encoder cable is bundled with a high-current line or near high-current line.	Change the encoder cable layout so that no surge is applied.
	FG varies because machine such as welder installed on servomotor side.	Check if grounding of the machine is correctly grounded.	Ground encoder to FG; do not share a ground with a machine.
	SERVOPACK pulse count error due to noise	Check if the signal line from the encoder is influenced by noise.	Take a measure against noise for the encoder wiring.
	Excessive vibration and shock to the encoder	Vibration from the machine or servomotor due to incorrect installation	Reduce vibration for the machine or mount the servomotor securely.
	Encoder fault	Encoder fault	Replace the servomotor.
SERVOPACK fault	SERVOPACK fault	Replace the SERVOPACK.	
Position Error (without alarm)	Unsecured coupling between machine and servomotor	Check if a position error occurs at the coupling between machine and servomotor.	Secure the coupling between the machine and servomotor.
	Noise interference due to improper input signal cable specifications	The input signal cable specifications must be: Tinned annealed copper twisted-pair or twisted-pair shielded wires with core 0.12 mm ² (0.0002 in ²) min.	Use input signal cable with the specified specifications.
	Noise interference because the input signal cable distance is too long.	The maximum allowable cable length is 3 m (9.84 ft).	The input signal cable distance must be within the specified range.
	Encoder fault (pulse count does not change)	Encoder fault.	Replace the servomotor.
Servomotor Overheated	Ambient temperature too high	Measure servomotor ambient temperature.	Reduce ambient temperature to the maximum allowable value of 40°C (104 °F) or lower.
	Servomotor surface dirty	Visual check	Clean dust and oil from motor surface.
	Overloaded	Run under no load.	Reduce load or replace with larger capacity servomotor.

9.2 Inspection and Maintenance

9.2.1 Servomotor Inspection

The AC servomotors are brushless. Simple, daily inspection is sufficient. The inspection and maintenance frequencies in Table 9.6 are only guidelines. Increase or decrease the frequency to suit the operating conditions and environment.

IMPORTANT

During inspection and maintenance, do not disassemble the servomotor. If disassembly of the servomotor is required, contact your Yaskawa representative.

Table 9.6 Servomotor Inspections

Item	Frequency	Procedure	Comments
Vibration and Noise	Daily	Touch and listen.	Levels higher than normal?
Exterior	According to degree of contamination	Clean with cloth or compressed air.	–
Insulation Resistance Measurement	At least once a year	Disconnect SERVOPACK and test insulation resistance at 500 V. Must exceed 10 MΩ . *	Contact your Yaskawa representative if the insulation resistance is below 10 MΩ .
Replacing Oil Seal	At least once every 5,000 hours	Remove servomotor from machine and replace oil seal.	Applies only to servomotors with oil seals.
Overhaul	At least once every 20,000 hours or 5 years	Contact your Yaskawa representative.	–

* Measure across the servomotor FG and the phase-U, phase-V, or phase-W power line.

9.2.2 SERVOPACK Inspection

For inspection and maintenance of the SERVOPACK, follow the inspection procedures in Table 9.7 at least once every year. Other routine inspections are not required.

Table 9.7 SERVOPACK Inspections

Item	Frequency	Procedure	Comments
Exterior	At least once a year	Check for dust, dirt, and oil on the surfaces.	Clean with cloth or compressed air.
Loose Screws		Check for loose terminal block and connector screws.	Tighten any loose screws.

9.2.3 SERVOPACK's Parts Replacement Schedule

The following electric or electronic parts are subject to mechanical wear or deterioration over time. To avoid failure, replace these parts at the frequency indicated.

Refer to the standard replacement period in the following table, contact your Yaskawa representative. After an examination of the part in question, we will determine whether the parts should be replaced or not.

The parameters of any SERVOPACKs overhauled by Yaskawa are reset to the factory settings before shipping. Be sure to confirm that the parameters are properly set before starting operation.

Table 9.8 Periodical Part Replacement

Part	Standard Replacement Period	Operating Conditions
Cooling Fan	4 to 5 years	<ul style="list-style-type: none"> • Ambient Temperature: Annual average of 30 °C (86 °F) • Load Factor: 80% max. • Operation Rate: 20 hours/day max.
Smoothing Capacitor	7 to 8 years	
Relays	–	
Fuses	10 years	
Aluminum Electrolytic Capacitor on Circuit Board	5 years	

10

Appendix

10.1 Utility Functions	10-2
10.1.1 List of Parameters	10-3
10.2 Monitor Modes	10-10

10.1 Utility Functions

The following list shows the available utility functions.

Parameter No.	Function	Remarks
Fn000	Alarm traceback data display	–
Fn002	JOG mode operation	○
Fn003	Origin search mode	○
Fn004	Program JOG operation	○
Fn005	Initialize parameter settings	○
Fn006	Clear alarm traceback data	○
Fn008	Absolute encoder multi-turn reset and encoder alarm reset	○
Fn00E	Automatic offset-adjustment of motor current detection signal	○
Fn00F	Manual offset-adjustment of motor current detection signal	○
Fn010	Write prohibited setting	–
Fn011	Check servomotor models	–
Fn012	Software version display	–
Fn013	Multi-turn limit value setting change when a Multi-turn Limit Disagreement alarm (A.CC0) occurs	○
Fn019	EasyFFT	○
Fn01E*	SERVOPACK and servomotor ID Display	○

* Fn01E can be operated only from the JUSP-OP05A digital operator.

Note: When the parameters marked with “○” in remarks column are set for Write Prohibited Setting (Fn010), the indication shown below appears and such parameters cannot be changed.

10.1.1 List of Parameters

(1) Parameter Display

Parameter settings are displayed in two patterns as shown below.

Parameter Type	Display of Digital Operator
Parameters for function selection	Hexadecimal display for each digit
Parameters for constant settings	Decimal display in five digits

Since each digit in the function selection parameters has a meaning, the value can only be changed for each individual digit. Each digit displays a value within its own setting range.

(2) Definition of Display for Function Selection Parameters

Each digit of the function selection parameters has a unique meaning.

For example, the rightmost digit of parameter Pn000 is expressed as “Pn000.0.”

IMPORTANT

- Each digit of the function selection parameters is defined as shown below. The following explains the purpose of each digit of a parameter.

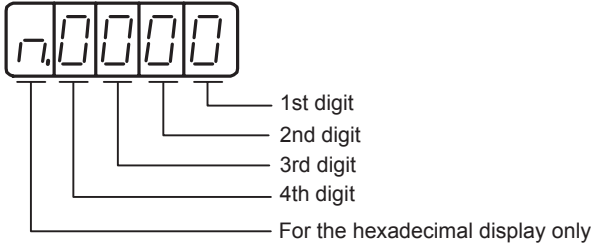

How to Display Parameters

- Pn000.0: Indicates the value for the 1st digit of parameter Pn000.
- Pn000.1: Indicates the value for the 2nd digit of parameter Pn000.
- Pn000.2: Indicates the value for the 3rd digit of parameter Pn000.
- Pn000.3: Indicates the value for the 4th digit of parameter Pn000.

- After changing the parameters with “After restart” mentioned in “Setting Validation” column in the table on the next page, turn OFF the main circuit and control power supplies and then turn them ON again to enable the new settings.

10.1.1 List of Parameters

Parameter No.	Name	Setting Range	Units	Factory Setting	Setting Validation	Reference Section																	
Pn001	Function Selection Application Switch 1	–	–	0000	After restart	–																	
	<div style="display: flex; align-items: flex-start;"> <div style="margin-right: 20px;"> <p>3rd digit</p><input type="checkbox"/></div> <div style="margin-right: 20px;"> <p>2nd digit</p><input type="checkbox"/></div> <div style="margin-right: 20px;"> <p>1st digit</p><input type="checkbox"/></div> <div style="margin-right: 20px;"> <p>0 digit</p><input type="checkbox"/></div> </div> <div style="margin-left: 20px;"> <p>n.</p> </div> <div style="margin-left: 20px;"> <table border="1" style="width: 100%;"> <tr><th colspan="2">Servo OFF or Alarm Stop Mode</th></tr> <tr><td>0</td><td>Stops motor by applying dynamic brake (DB).</td></tr> <tr><td>1</td><td>Stops motor by applying dynamic brake (DB) and then releases DB.</td></tr> <tr><td>2</td><td>Makes motor coast to stop without using dynamic brake (DB).</td></tr> </table> <table border="1" style="width: 100%;"> <tr><th colspan="2">Overtravel Stop Mode</th></tr> <tr><td>0</td><td>Same setting as Pn001.0 (Stops motor by applying DB or by coasting).</td></tr> </table> <table border="1" style="width: 100%;"> <tr><th colspan="2">AC/DC Power Input Selection</th></tr> <tr><td>0</td><td>Not applicable to DC power input: Input AC power supply through L1, L2, and (L3) terminals.</td></tr> <tr><td>1</td><td>Applicable to DC power input: Input DC power supply between B1/⊕ and ⊖, or input DC power supply between B1/⊕ and ⊖1.</td></tr> </table> </div>						Servo OFF or Alarm Stop Mode		0	Stops motor by applying dynamic brake (DB).	1	Stops motor by applying dynamic brake (DB) and then releases DB.	2	Makes motor coast to stop without using dynamic brake (DB).	Overtravel Stop Mode		0	Same setting as Pn001.0 (Stops motor by applying DB or by coasting).	AC/DC Power Input Selection		0	Not applicable to DC power input: Input AC power supply through L1, L2, and (L3) terminals.	1
Servo OFF or Alarm Stop Mode																							
0	Stops motor by applying dynamic brake (DB).																						
1	Stops motor by applying dynamic brake (DB) and then releases DB.																						
2	Makes motor coast to stop without using dynamic brake (DB).																						
Overtravel Stop Mode																							
0	Same setting as Pn001.0 (Stops motor by applying DB or by coasting).																						
AC/DC Power Input Selection																							
0	Not applicable to DC power input: Input AC power supply through L1, L2, and (L3) terminals.																						
1	Applicable to DC power input: Input DC power supply between B1/⊕ and ⊖, or input DC power supply between B1/⊕ and ⊖1.																						
Pn002	Function Selection Application Switch 2	–	–	0000	After restart	–																	
	<div style="display: flex; align-items: flex-start;"> <div style="margin-right: 20px;"> <p>3rd digit</p><input type="checkbox"/></div> <div style="margin-right: 20px;"> <p>2nd digit</p><input type="checkbox"/></div> <div style="margin-right: 20px;"> <p>1st digit</p><input type="checkbox"/></div> <div style="margin-right: 20px;"> <p>0 digit</p><input type="checkbox"/></div> </div> <div style="margin-left: 20px;"> <p>n.</p> </div> <div style="margin-left: 20px;"> <table border="1" style="width: 100%;"> <tr><th colspan="2">Reserved (Do not change)</th></tr> </table> <table border="1" style="width: 100%;"> <tr><th colspan="2">Reserved (Do not change)</th></tr> </table> <table border="1" style="width: 100%;"> <tr><th colspan="2">Absolute Encoder Usage</th></tr> <tr><td>0</td><td>Uses absolute encoder as an absolute encoder.</td></tr> <tr><td>1</td><td>Uses absolute encoder as an incremental encoder.</td></tr> </table> </div>						Reserved (Do not change)		Reserved (Do not change)		Absolute Encoder Usage		0	Uses absolute encoder as an absolute encoder.	1	Uses absolute encoder as an incremental encoder.							
Reserved (Do not change)																							
Reserved (Do not change)																							
Absolute Encoder Usage																							
0	Uses absolute encoder as an absolute encoder.																						
1	Uses absolute encoder as an incremental encoder.																						

Parameter No.	Name	Setting Range	Units	Factory Setting	Setting Validation	Reference Section																																				
Pn006	Function Selection Application Switch 6	-	-	0002	Immediately	8.2																																				
<div style="display: flex; align-items: flex-start;"> <div style="margin-right: 20px;"> <p>3rd digit</p> <p>2nd digit</p> <p>1st digit</p> <p>0 digit</p> <p>n. <input type="checkbox"/> <input type="checkbox"/> <input type="checkbox"/> <input type="checkbox"/></p> </div> <div style="border: 1px solid black; padding: 5px;"> <p>Analog Monitor 1 Signal Selection</p> <table border="1"> <tr><td>00</td><td>Motor Speed (1 V/1000 min⁻¹)</td></tr> <tr><td>01</td><td>Reserved</td></tr> <tr><td>02</td><td>Torque reference (1 V/100%) - Gravity compensation (Pn422)*</td></tr> <tr><td>03</td><td>Reserved</td></tr> <tr><td>04</td><td>Reserved</td></tr> <tr><td>05</td><td>Reserved</td></tr> <tr><td>06</td><td>Reserved</td></tr> <tr><td>08</td><td>Reserved</td></tr> <tr><td>0B</td><td>Reserved</td></tr> <tr><td>0C</td><td>Reserved</td></tr> <tr><td>0D</td><td>Reserved</td></tr> <tr><td>0E</td><td>Reserved</td></tr> <tr><td>0F</td><td>Reserved</td></tr> </table> </div> <div style="border: 1px solid black; padding: 5px; margin-top: 10px;"> <p>Analog Monitor 1 Signal Multiplication Selection</p> <table border="1"> <tr><td>0</td><td>× 1</td></tr> <tr><td>1</td><td>× 10</td></tr> <tr><td>2</td><td>× 100</td></tr> <tr><td>3</td><td>× 1/10</td></tr> <tr><td>4</td><td>× 1/100</td></tr> </table> </div> <div style="border: 1px solid black; padding: 5px; margin-top: 10px; background-color: #333; color: white;"> <p>Reserved (Do not change)</p> </div> </div> <p style="margin-top: 20px;">Analog monitor 1 output voltage = [(-1) - Signal selection (Pn006.0) - Signal multiplication (Pn006.2)] + Offset voltage (Pn550) * The torque reference outputs a value "Torque reference value output from SERVOPACK - Gravity compensation (Pn422)" for monitor.</p>							00	Motor Speed (1 V/1000 min ⁻¹)	01	Reserved	02	Torque reference (1 V/100%) - Gravity compensation (Pn422)*	03	Reserved	04	Reserved	05	Reserved	06	Reserved	08	Reserved	0B	Reserved	0C	Reserved	0D	Reserved	0E	Reserved	0F	Reserved	0	× 1	1	× 10	2	× 100	3	× 1/10	4	× 1/100
00	Motor Speed (1 V/1000 min ⁻¹)																																									
01	Reserved																																									
02	Torque reference (1 V/100%) - Gravity compensation (Pn422)*																																									
03	Reserved																																									
04	Reserved																																									
05	Reserved																																									
06	Reserved																																									
08	Reserved																																									
0B	Reserved																																									
0C	Reserved																																									
0D	Reserved																																									
0E	Reserved																																									
0F	Reserved																																									
0	× 1																																									
1	× 10																																									
2	× 100																																									
3	× 1/10																																									
4	× 1/100																																									

Parameter No.	Name	Setting Range	Units	Factory Setting	Setting Validation	Reference Section																																				
Pn007	Function Selection Application Switch 7	–	–	0000	Immediately	8.2																																				
	<div style="display: flex; align-items: flex-start;"> <div style="margin-right: 20px;"> <p>3rd digit</p><input type="checkbox"/></div> <div style="margin-right: 20px;"> <p>2nd digit</p><input type="checkbox"/></div> <div style="margin-right: 20px;"> <p>1st digit</p><input type="checkbox"/></div> <div> <p>0 digit</p><input type="checkbox"/></div> </div> <div style="margin-left: 20px;"> <p>n.</p><input type="checkbox"/></div> <div style="margin-left: 20px;"> <p>Analog Monitor 2 Signal Selection</p> <table border="1"> <tr><td>00</td><td>Motor speed (1 V/1000 min⁻¹)</td></tr> <tr><td>01</td><td>Reserved</td></tr> <tr><td>02</td><td>Torque reference (1 V/100%) - Gravity compensation (Pn422)*</td></tr> <tr><td>03</td><td>Reserved</td></tr> <tr><td>04</td><td>Reserved</td></tr> <tr><td>05</td><td>Reserved</td></tr> <tr><td>06</td><td>Reserved</td></tr> <tr><td>08</td><td>Reserved</td></tr> <tr><td>0B</td><td>Reserved</td></tr> <tr><td>0C</td><td>Reserved</td></tr> <tr><td>0D</td><td>Reserved</td></tr> <tr><td>0E</td><td>Reserved</td></tr> <tr><td>0F</td><td>Reserved</td></tr> </table> </div> <div style="margin-left: 20px;"> <p>Analog Monitor 2 Signal Multiplication Selection</p> <table border="1"> <tr><td>0</td><td>× 1</td></tr> <tr><td>1</td><td>× 10</td></tr> <tr><td>2</td><td>× 100</td></tr> <tr><td>3</td><td>× 1/10</td></tr> <tr><td>4</td><td>× 1/100</td></tr> </table> </div> <div style="margin-left: 20px;"> <p>Reserved (Do not change)</p> </div>						00	Motor speed (1 V/1000 min ⁻¹)	01	Reserved	02	Torque reference (1 V/100%) - Gravity compensation (Pn422)*	03	Reserved	04	Reserved	05	Reserved	06	Reserved	08	Reserved	0B	Reserved	0C	Reserved	0D	Reserved	0E	Reserved	0F	Reserved	0	× 1	1	× 10	2	× 100	3	× 1/10	4	× 1/100
00	Motor speed (1 V/1000 min ⁻¹)																																									
01	Reserved																																									
02	Torque reference (1 V/100%) - Gravity compensation (Pn422)*																																									
03	Reserved																																									
04	Reserved																																									
05	Reserved																																									
06	Reserved																																									
08	Reserved																																									
0B	Reserved																																									
0C	Reserved																																									
0D	Reserved																																									
0E	Reserved																																									
0F	Reserved																																									
0	× 1																																									
1	× 10																																									
2	× 100																																									
3	× 1/10																																									
4	× 1/100																																									

Parameter No.	Name	Setting Range	Units	Factory Setting	Setting Validation	Reference Section
Pn101	Speed Loop Integral Time Constant	0.15 to 512.00 ms	0.01 ms	20.00 ms	Immediately	–
Pn102	Position Loop Gain	1.0 to 2000.0/s	0.1/s	40.0/s	Immediately	–
Pn103	Moment of Inertia Ratio	0 to 20000%	1%	0%	Immediately	–
Pn205	Multi-turn Limit Setting *	0 to 65535 rev	rev	65535 rev	After restart	–
Pn212	Reserved Parameter	–	–	2048 P/Rev	After restart	–
Pn304	JOG Speed	0 to 10000 min ⁻¹	1 min ⁻¹	500 min ⁻¹	Immediately	–
Pn401	1st Step Torque Reference Filter Time Constant	0.00 to 655.35 ms	0.01 ms	0.00 ms	Immediately	8.1
Pn402	Forward Torque Limit	0 to 800%	1%	800%	Immediately	–
Pn403	Reverse Torque Limit	0 to 800%	1%	800%	Immediately	–
Pn408	Torque Related Function Switch	–	–	0000	After restart	8.1

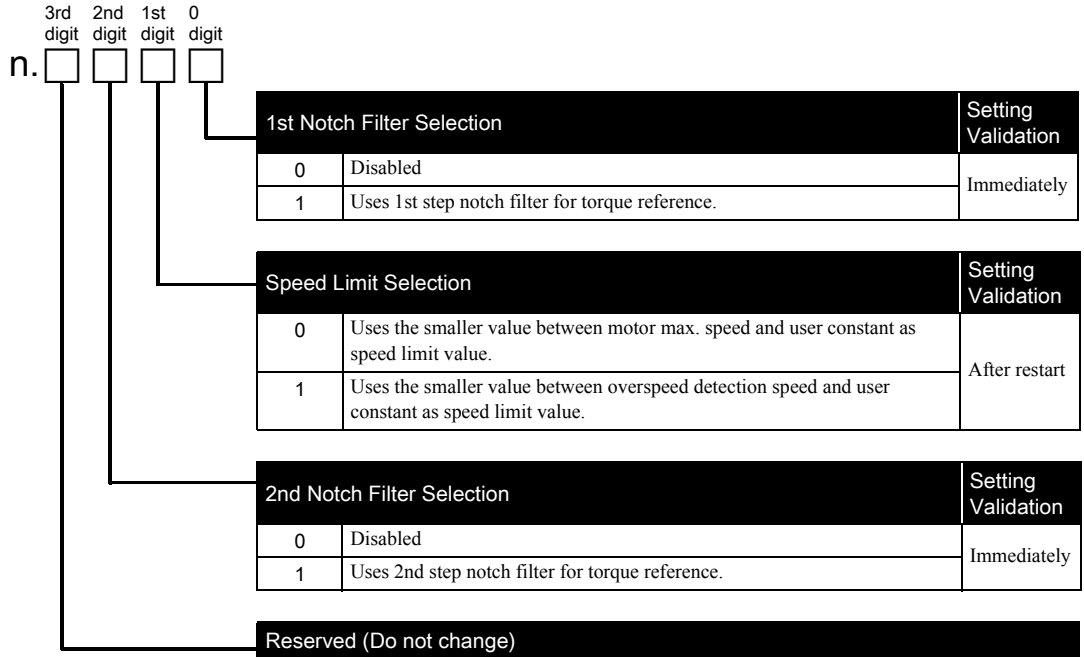

* The multiturn limit must be changed only for special applications. Changing this limit inappropriately or unintentionally can be dangerous.

10.1.1 List of Parameters

Parameter No.	Name	Setting Range	Units	Factory Setting	Setting Validation	Reference Section														
Pn409	1st Step Notch Filter Frequency	50 to 2000 Hz	1 Hz	2000 Hz	Immediately	8.1														
Pn40A	1st Step Notch Filter Q Value	70 to 10.00	0.01	0.70	Immediately															
Pn40C	2nd Step Notch Filter Frequency	50 to 2000 Hz	1 Hz	2000 Hz	Immediately															
Pn40D	2nd Step Notch Filter Q Value	70 to 10.00	0.01	0.70	Immediately															
Pn40F	2nd Step 2nd Torque Reference Filter Frequency	100 to 2000 Hz	1 Hz	2000 Hz	Immediately															
Pn410	2nd Step 2nd Torque Reference Filter Q Value	50 to 1000	0.01	0.70	Immediately															
Pn411	3rd Step Torque Reference Filter Time Constant	0 to 65535 μ s	1 μ s	0 μ s	Immediately															
Pn422	Gravity Compensation Torque	-200.00 to 200.00%	0.01 %	0.00%	Immediately	-														
Pn502	Zero Speed Level	1 to 10000 min^{-1}	1 min^{-1}	20 min^{-1}	Immediately	-														
Pn506	Brake Reference - Servo OFF Delay Time	0 to 50 (0 to 500 ms)	10 ms	0 ms	Immediately	-														
Pn509	Instantaneous Power Cut Hold time	20 to 1000 ms	1 ms	20 ms	Immediately	-														
Pn520	Excessive Position Error Alarm Level	0 to 1073741823 ($2^{30}-1$) reference units	1 reference unit	262144 reference units	Immediately	-														
Pn530	Program JOG Operation Related Switch	-	-	0000	Immediately	-														
	<table border="1"> <thead> <tr> <th colspan="2">Program JOG Operation Related Switch (Refer to 7.2.4.)</th> </tr> </thead> <tbody> <tr> <td>0</td> <td>(Waiting time Pn535 \rightarrow Forward movement Pn531) \times Number of times of movement Pn536</td> </tr> <tr> <td>1</td> <td>(Waiting time Pn535 \rightarrow Reverse movement Pn531) \times Number of times of movements Pn536</td> </tr> <tr> <td>2</td> <td>(Waiting time Pn535 \rightarrow Forward movement Pn531) \times Number of times of movements Pn536 (Waiting time Pn535 \rightarrow Reverse movement Pn531) \times Number of times of movements Pn536</td> </tr> <tr> <td>3</td> <td>(Waiting time Pn535 \rightarrow Reverse movement Pn531) \times Number of times of movements Pn536 (Waiting time Pn535 \rightarrow Forward movement Pn531) \times Number of times of movements Pn536</td> </tr> <tr> <td>4</td> <td>(Waiting time Pn535 \rightarrow Forward movement Pn531 \rightarrow Waiting time Pn535 \rightarrow Reverse movement Pn531) \times Number of times of movement Pn536</td> </tr> <tr> <td>5</td> <td>(Waiting time Pn535 \rightarrow Reverse movement Pn531 \rightarrow Waiting time Pn535 \rightarrow Forward movement Pn531) \times Number of times of movement Pn536</td> </tr> </tbody> </table>						Program JOG Operation Related Switch (Refer to 7.2.4.)		0	(Waiting time Pn535 \rightarrow Forward movement Pn531) \times Number of times of movement Pn536	1	(Waiting time Pn535 \rightarrow Reverse movement Pn531) \times Number of times of movements Pn536	2	(Waiting time Pn535 \rightarrow Forward movement Pn531) \times Number of times of movements Pn536 (Waiting time Pn535 \rightarrow Reverse movement Pn531) \times Number of times of movements Pn536	3	(Waiting time Pn535 \rightarrow Reverse movement Pn531) \times Number of times of movements Pn536 (Waiting time Pn535 \rightarrow Forward movement Pn531) \times Number of times of movements Pn536	4	(Waiting time Pn535 \rightarrow Forward movement Pn531 \rightarrow Waiting time Pn535 \rightarrow Reverse movement Pn531) \times Number of times of movement Pn536	5	(Waiting time Pn535 \rightarrow Reverse movement Pn531 \rightarrow Waiting time Pn535 \rightarrow Forward movement Pn531) \times Number of times of movement Pn536
	Program JOG Operation Related Switch (Refer to 7.2.4.)																			
	0	(Waiting time Pn535 \rightarrow Forward movement Pn531) \times Number of times of movement Pn536																		
	1	(Waiting time Pn535 \rightarrow Reverse movement Pn531) \times Number of times of movements Pn536																		
	2	(Waiting time Pn535 \rightarrow Forward movement Pn531) \times Number of times of movements Pn536 (Waiting time Pn535 \rightarrow Reverse movement Pn531) \times Number of times of movements Pn536																		
	3	(Waiting time Pn535 \rightarrow Reverse movement Pn531) \times Number of times of movements Pn536 (Waiting time Pn535 \rightarrow Forward movement Pn531) \times Number of times of movements Pn536																		
	4	(Waiting time Pn535 \rightarrow Forward movement Pn531 \rightarrow Waiting time Pn535 \rightarrow Reverse movement Pn531) \times Number of times of movement Pn536																		
	5	(Waiting time Pn535 \rightarrow Reverse movement Pn531 \rightarrow Waiting time Pn535 \rightarrow Forward movement Pn531) \times Number of times of movement Pn536																		
Reserved (Do not change)																				
Reserved (Do not change)																				
Reserved (Do not change)																				
Pn531	Program JOG Movement Distance	1 to 1073741824(2^{30}) reference units	1 reference unit	32768 reference units	Immediately	-														
Pn533	Program JOG Movement Speed	1 to 10000 min^{-1}	1 min^{-1}	500 min^{-1}	Immediately	-														

Parameter No.	Name	Setting Range	Units	Factory Setting	Setting Validation	Reference Section
Pn534	Program JOG Acceleration/Deceleration Time	2 to 10000 ms	1 ms	100 ms	Immediately	–
Pn535	Program JOG Waiting Time	0 to 10000 ms	1 ms	100 ms	Immediately	–
Pn536	Number of Times of Program JOG Movement	1 to 1000 times	1 time	1 time	Immediately	–
Pn550	Analog Monitor 1 Offset Voltage	-1000.0 to 1000.0 V	0.1 V	0.0 V	Immediately	8.2
Pn551	Analog Monitor 2 Offset Voltage	-1000.0 to 1000.0 V	0.1 V	0.0 V	Immediately	
Pn600	Regenerative Resistor Capacity ^{*1}	Depends on SERVOPACK Capacity ^{*2}	10 W	0 W	Immediately	–

* 1. Normally set to “0.” When using an external regenerative resistor, set the capacity (W) of the regenerative resistor.

* 2. The upper limit is the maximum output capacity (W) of the SERVOPACK.

10.2 Monitor Modes

The following list shows the monitor modes that are available.

Parameter No.	Description	Unit
Un000	Motor speed	min ⁻¹
Un002	Internal torque reference (in percentage to the rated torque)	%
Un003	Rotation angle 1 (32-bit decimal code)	pulse
Un004	Rotation angle 2 (Angle to the zero-point (electrical angle))	deg
Un005	Input signal monitor	–
Un006	Output signal monitor	–
Un009	Accumulated load ratio (in percentage to the rated torque: effective torque in cycle of 10 seconds)	%
Un00A	Regenerative load ratio (in percentage to the processable regenerative power: regenerative power consumption in cycle of 10 seconds)	%
Un00B	Power consumed by DB resistance (in percentage to the processable power at DB activation: displayed in cycle of 10 seconds)	%
Un00D	Feedback pulse counter (32-bit decimal code)	pulse

Note: Except for the parameters listed here, all other parameters are reserved parameters.

INDEX

Numerics

400-V power supply voltage ----- 5-18

A

absolute encoder battery ----- 4-13
 AC/DC reactors for harmonic suppression ----- 4-21, 5-19
 alarm display and troubleshooting ----- 9-5
 alarm display table ----- 9-2
 alarm reset ----- 9-2
 ambient/storage humidity ----- 3-2
 ambient/storage temperature ----- 3-2
 analog monitor ----- 8-5
 analog monitor cable ----- 2-24

B

battery case ----- 4-13
 battery for absolute encoder ----- 2-25
 battery installed on the host controller end ----- 4-13
 brake power supply unit ----- 4-10
 built-in regenerative resistor ----- 5-20

C

cable selection ----- 2-7
 SGMAS and SGMPS servomotors ----- 2-7
 SGMCS servomotors ----- 2-20
 SGMSS Servomotor ----- 2-15
 cable type ----- 4-3
 cables for analog monitor ----- 4-8
 cables for connecting personal computers ----- 4-8
 CE marking ----- 1-11
 checking products ----- 1-2
 CN1 cables for I/O signals ----- 4-6
 CN1 terminal layout ----- 5-9
 CN2 terminal layout ----- 5-7
 connecting regenerative resistors ----- 5-20
 connectors for main circuit, control power supply,
 and servomotor cable ----- 4-4
 continuous output current ----- 3-2
 CSA standards ----- 1-11
 cyclic commands ----- 6-10
 cyclic responses ----- 6-10

D

digital operator ----- 2-24, 4-8

E

examples of I/O signal connections ----- 5-8
 external regenerative resistor ----- 4-11
 external regenerative resistors ----- 5-20

F

flexible cables ----- 5-23
 frequency characteristics ----- 3-2
 fuse capacity ----- 2-25

G

ground terminal ----- 4-2
 grounding ----- 5-14

H

hot start ----- 3-12

I

I/O signal
 names and functions ----- 5-10
 input power supply ----- 3-2
 inspection and maintenance ----- 9-21

J

jog mode operation ----- 7-2

L

LED 7-segment display ----- 6-9
 load moment of inertia ----- 3-13
 load regulation ----- 3-2

M

magnetic contactor ----- 4-18
 main circuit
 terminal names and descriptions ----- 5-2
 wiring examples ----- 5-4
 main circuit power input terminals ----- 4-2
 max. output current ----- 3-2
 molded-case circuit breaker ----- 2-25
 molded-case circuit breaker (MCCB) ----- 4-14
 monitor mode ----- 10-10

N

noise filters ----- 2-26, 4-15
 noise interference ----- 5-12
 notch filters ----- 8-3

P

parameter list ----- 10-3
 peripheral device selection ----- 2-24
 peripheral devices ----- 4-8
 precautions for wiring SynqNet cables ----- 6-5

Q

Q value ----- 8-3

R

reactors
 connecting a reactor ----- 5-19
 types ----- 5-19
 recommended noise filters ----- 5-14
 regenerative resistor capacity ----- 5-21
 regenerative resistors ----- 2-27
 replacing oil seal ----- 9-21

S

service commands	6-11
servo alarm (ALM) output	9-2
servo system configurations	1-6
servomotor inspection	9-21
servomotor stop method	9-2
servomotors	
nameplate	1-2
product part names	1-4
SERVOPACK inspection	9-21
SERVOPACK main circuit wire size	4-2
SERVOPACK standard replacement period	9-22
SERVOPACK's parts replacement schedule	9-22
SERVOPACKs	
applicable servomotors	2-6
dimensional drawings	3-17
installation	3-4
internal block diagrams	3-6
load moment of inertia	3-12
model designations	2-5
nameplate	1-3
overload characteristics	3-12
power losses	3-11
product part names	1-5
ratings and specifications	3-2
speed control range	3-2
starting time	3-13
stopping time	3-13
supported SynqNet features	6-10
surge protector	4-20
switch ID setting	6-8
SynqNet communications	
grounding	6-7
specifications and configurations	6-4
SynqNet communications connection example	6-4
SynqNet connectors (CN6A and CN6B)	5-11
SynqNet packet timing	6-2
SynqNet port LED indicators	6-8

T

temperature regulation	3-2
temperature-resistant vinyl cable	4-3
torque control tolerance	3-2
torque filters	8-2
trial operation	7-2
troubleshooting	9-2
troubleshooting for malfunction without alarm display	9-17

U

UL standards	1-11
using more than one SERVOPACK	5-17
using noise filter	5-14
utility functions	10-2

V

vibration/shock resistance	3-2
vinyl cable	4-3
voltage regulation	3-2
voltage resistance test	3-5

W

warning display and troubleshooting	9-15
warning displays	9-4
wiring for noise control	5-13
wiring main circuit terminal block	5-3
wiring precautions	5-12

Revision History

The revision dates and numbers of the revised manuals are given on the bottom of the back cover.

MANUAL NO. SIEP S800000 25A

© Printed in Japan November 2004 04-11
└── Date of printing └── Date of original publication

Date of Printing	Rev. No.	Section	Revised Contents
November 2004	-		First edition

Σ-III Series SGM□S/SGDS USER'S MANUAL

For SynqNet Communications

IRUMA BUSINESS CENTER

480, Kamifujisawa, Iruma, Saitama 358-8555, Japan
Phone 81-4-2962-5696 Fax 81-4-2962-6138

YASKAWA ELECTRIC AMERICA, INC.

2121 Norman Drive South, Waukegan, IL 60085, U.S.A.
Phone 1-847-887-7000 Fax 1-847-887-7370

MOTOMAN INC. HEADQUARTERS

805 Liberty Lane West Carrollton, OH 45449, U.S.A.
Phone 1-937-847-6200 Fax 1-937-847-6277

YASKAWA ELÉTRICO DO BRASIL COMÉRCIO LTD.A.

Avenida Fagundes Filho, 620 Bairro Saude-Sao Paulo-SP, Brazil CEP: 04304-000
Phone 55-11-5071-2552 Fax 55-11-5581-8795

YASKAWA ELECTRIC EUROPE GmbH

Am Kronberger Hang 2, 65824 Schwalbach, Germany
Phone 49-6196-569-300 Fax 49-6196-569-312

Motoman Robotics Europe AB

Box 504 S38525 Torsås, Sweden
Phone 46-486-48800 Fax 46-486-41410

Motoman Robotec GmbH

Kammerfeldstraße 1, 85391 Allershausen, Germany
Phone 49-8166-90-100 Fax 49-8166-90-103

YASKAWA ELECTRIC UK LTD.

1 Hunt Hill Orchardton Woods Cumbernauld, G68 9LF, United Kingdom
Phone 44-1236-735000 Fax 44-1236-458182

YASKAWA ELECTRIC KOREA CORPORATION

7F, Doore Bldg. 24, Yeoido-dong, Youngdungpo-Ku, Seoul 150-877, Korea
Phone 82-2-784-7844 Fax 82-2-784-8495

YASKAWA ELECTRIC (SINGAPORE) PTE. LTD.

151 Lorong Chuan, #04-01, New Tech Park Singapore 556741, Singapore
Phone 65-6282-3003 Fax 65-6289-3003

YASKAWA ELECTRIC (SHANGHAI) CO., LTD.

No.18 Xizang Zhong Road. Room 1805, Harbour Ring Plaza Shanghai 20000, China
Phone 86-21-5385-2200 Fax 86-21-5385-3299

YATEC ENGINEERING CORPORATION

4F., No.49 Wu Kong 6 Rd, Wu-Ku Industrial Park, Taipei, Taiwan
Phone 886-2-2298-3676 Fax 886-2-2298-3677

YASKAWA ELECTRIC (HK) COMPANY LIMITED

Rm. 2909-10, Hong Kong Plaza, 186-191 Connaught Road West, Hong Kong
Phone 852-2803-2385 Fax 852-2547-5773

BEIJING OFFICE

Room No. 301 Office Building of Beijing International Club, 21
Jianguomenwai Avenue, Beijing 100020, China
Phone 86-10-6532-1850 Fax 86-10-6532-1851

TAIPEI OFFICE

9F, 16, Nanking E. Rd., Sec. 3, Taipei, Taiwan
Phone 886-2-2502-5003 Fax 886-2-2505-1280

SHANGHAI YASKAWA-TONGJI M & E CO., LTD.

27 Hui He Road Shanghai China 200437
Phone 86-21-6553-6060 Fax 86-21-5588-1190

BEIJING YASKAWA BEIKE AUTOMATION ENGINEERING CO., LTD.

30 Xue Yuan Road, Haidian, Beijing P.R. China Post Code: 100083
Phone 86-10-6233-2782 Fax 86-10-6232-1536

SHOUGANG MOTOMAN ROBOT CO., LTD.

7, Yongchang-North Street, Beijing Economic Technological Investment & Development Area,
Beijing 100076, P.R. China
Phone 86-10-6788-0551 Fax 86-10-6788-2878



YASKAWA ELECTRIC CORPORATION

YASKAWA

In the event that the end user of this product is to be the military and said product is to be employed in any weapons systems or the manufacture thereof, the export will fall under the relevant regulations as stipulated in the Foreign Exchange and Foreign Trade Regulations. Therefore, be sure to follow all procedures and submit all relevant documentation according to any and all rules, regulations and laws that may apply.

Specifications are subject to change without notice for ongoing product modifications and improvements.

© 2004 YASKAWA ELECTRIC CORPORATION. All rights reserved.

MANUAL NO. SIEP S800000 25A

© Printed in Japan November 2004 04-11
04-8⑥