

Tachogeneratoren

Vollwelle mit EURO-Flansch B10

Mit eigener Lagerung

TDP 0,2, TDPZ 0,2



TDP 0,2

Technische Daten - elektrisch

Reversiertoleranz	≤0,1 %
Linearitätstoleranz	≤0,15 %
Temperaturkoeffizient	±0,05 %/K (Leerlauf)
Isolationsklasse	B
Kalibriertoleranz	±1 %
Klimatische Prüfung	Feuchte Wärme, konstant (IEC 60068-2-3, Ca)
Störfestigkeit	EN 61000-6-2
Störaussendung	EN 61000-6-3

TDP 0,2

Leistung	12 W (Drehzahl ≥3000 U/min)
Ankerkreis-Zeitkonstante	<75 µs
Leerlaufspannung	10...150 mV pro U/min

TDPZ 0,2

Leistung	2x 3 W (Drehzahl ≥3000 U/min)
Ankerkreis-Zeitkonstante	<40 µs
Leerlaufspannung	20...100 mV pro U/min

Merkmale

- Kurze Reaktionszeit
- Leerlaufspannung 10...150 mV pro U/min
- Redundanter Ausgang (TDPZ)
- EURO-Flansch B10 / Vollwelle ø11 mm
- Sehr hohe Schockfestigkeit
- Hohe Signalgüte über den gesamten Drehzahlbereich dank patentierter Longlife Technik
- Drehrichtungserkennung über Steuerung möglich

Optional

- Seeluft-/Tropenschutz
- Zweites Wellenende (B14) / Gehäusefuß (B3)
- Vollwelle ø7 und ø14 mm

Technische Daten - mechanisch

Baugröße (Flansch)	ø115 mm
Wellenart	ø11 mm Vollwelle ø7 mm Vollwelle (optional) ø14 mm Vollwelle (optional)
Flansch	EURO-Flansch B10
Schutzart DIN EN 60529	IP 55, IP 56 (optional)
Betriebsdrehzahl	≤10000 U/min
Drehmoment	1,5 Ncm
Zulässige Wellenbelastung	≤60 N axial ≤80 N radial
Werkstoffe	Gehäuse: Aluminium-Druckguss Welle: Edelstahl
Betriebstemperatur	-30...+130 °C
Widerstandsfähigkeit	DIN EN 60068-2-6 Vibration 10 g, 10-2000 Hz IEC 60068-2-27 Schock 300 g, 1 ms
Anschluss	Klemmenkasten

TDP 0,2

Trägheitsmoment Rotor	1,1 kgcm ²
Masse ca.	2,4 kg

TDPZ 0,2

Trägheitsmoment Rotor	1,2 kgcm ²
Masse ca.	2,9 kg

Tachogeneratoren

Vollwelle mit EURO-Flansch B10

Mit eigener Lagerung

TDP 0,2, TDPZ 0,2

Bestellbezeichnung

Tachogenerator

TDP0,2LT-

	Leerlaufspannung
6	10 mV pro U/min
7	20 mV pro U/min
10	30 mV pro U/min
5	40 mV pro U/min
4	60 mV pro U/min
3	100 mV pro U/min
1	150 mV pro U/min

Doppel-Tachogenerator

TDPZ0,2LT-

	Leerlaufspannung
7	20 mV pro U/min
5	40 mV pro U/min
4	60 mV pro U/min
3	100 mV pro U/min

Daten nach Typ

Typ	Leerlaufspannung U_0 [mV/U/min]	Min. erforderlicher Lastwiderstand in Abhängigkeit vom Drehzahlbereich [U/min]			Max. Betriebsdrehzahl n_{max} [U/min]	Anker-Widerstand $R_A(20^\circ C)$ [Ω]	Anker-Induktivität L_A [mH]
		0-3000 R_L [k Ω]	0-6000 R_L [k Ω]	0- n_{max} R_L [k Ω]			
TDP0,2LT-6	10	$\geq 0,1$	$\geq 0,3$	$\geq 0,9$	10000	3	6
TDP0,2LT-7	20	$\geq 0,3$	$\geq 1,2$	$\geq 3,3$	10000	11	23
TDP0,2LT-10	30	$\geq 0,7$	$\geq 2,7$	$\geq 7,5$	10000	26	50
TDP0,2LT-5	40	$\geq 1,2$	≥ 5	$\geq 13,5$	10000	47	90
TDP0,2LT-4	60	$\geq 2,7$	≥ 11	≥ 30	10000	99	200
TDP0,2LT-3	100	$\geq 7,5$	≥ 30	≥ 30	6000	271	550
TDP0,2LT-1	150	≥ 16	---	≥ 30	4000	630	1260

Doppel-Tachogenerator mit redundanten Ausgang
(Die Daten gelten für jeden der beiden Tachogeneratorausgänge)

TDPZ0,2LT-7	20	$\geq 1,2$	$\geq 4,8$	≥ 14	10000	19	45
TDPZ0,2LT-5	40	$\geq 4,8$	≥ 20	≥ 54	10000	70	170
TDPZ0,2LT-4	60	≥ 11	≥ 44	≥ 120	10000	160	390
TDPZ0,2LT-3	100	≥ 30	≥ 120	---	6000	445	1080

Überlagerte Welligkeit (für $\tau_{RC} = 0,7$ ms): $\leq 0,5\%$ (Spitze-Spitze) $\leq 0,2\%$ (effektiv)

Ersatzschaltbild

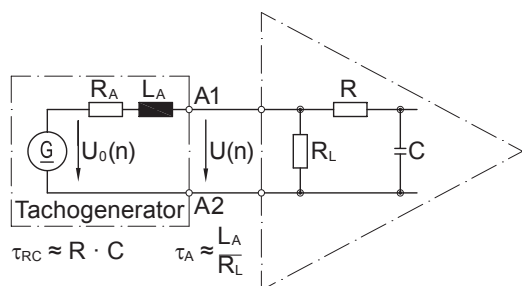

Polarität bei positiver Drehrichtung: A1 (TDPZ: 1A1, 2A1): + (VDE)
A2 (TDPZ: 1A2, 2A2): - (VDE)

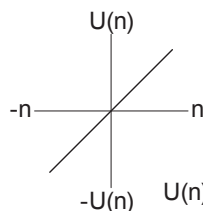

$$U(n) = U_0(n) \frac{R_L}{R_A + R_L} \approx U_0(n) \text{ für } R > R_L \gg R_A$$

Tachogeneratoren

Vollwelle mit EURO-Flansch B10

Mit eigener Lagerung

TDP 0,2, TDPZ 0,2

Anschlussbelegung

Ansicht A - Anschlussklemmen TDP 0,2

Polarität bei positiver Drehrichtung

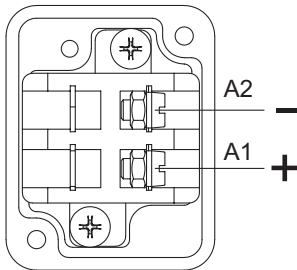

Ansicht A - Anschlussklemmen TDPZ 0,2

Polarität bei positiver Drehrichtung

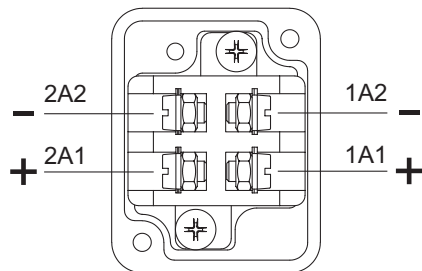

Zubehör

Kohlebürsten

Montagezubehör

K 35	Federscheiben-Kupplung für Vollwelle $\varnothing 6 \dots 12$ mm
K 50	Federscheiben-Kupplung für Vollwelle $\varnothing 11 \dots 16$ mm
K 60	Federscheiben-Kupplung für Vollwelle $\varnothing 11 \dots 22$ mm

Tachogeneratoren

Vollwelle mit EURO-Flansch B10

Mit eigener Lagerung

TDP 0,2, TDPZ 0,2

Abmessungen

TDP 0,2 (TDPZ 0,2) - Version mit Euro-Flansch (B10)

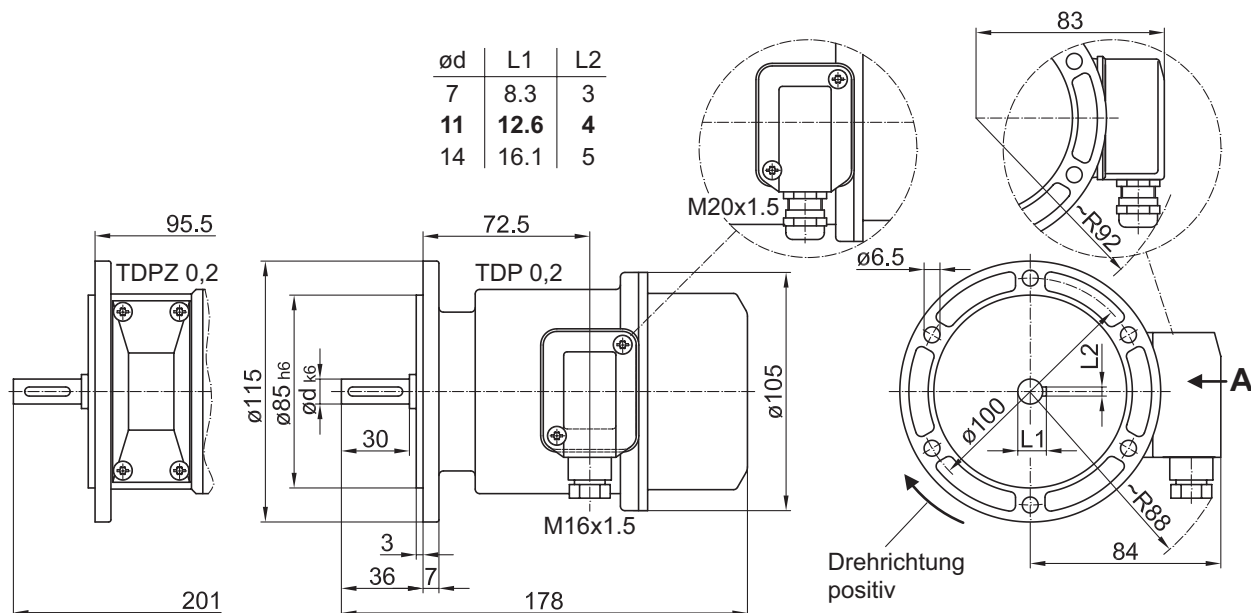

TDP 0,2 (TDPZ 0,2) - Version mit Gehäusefuss (B3)

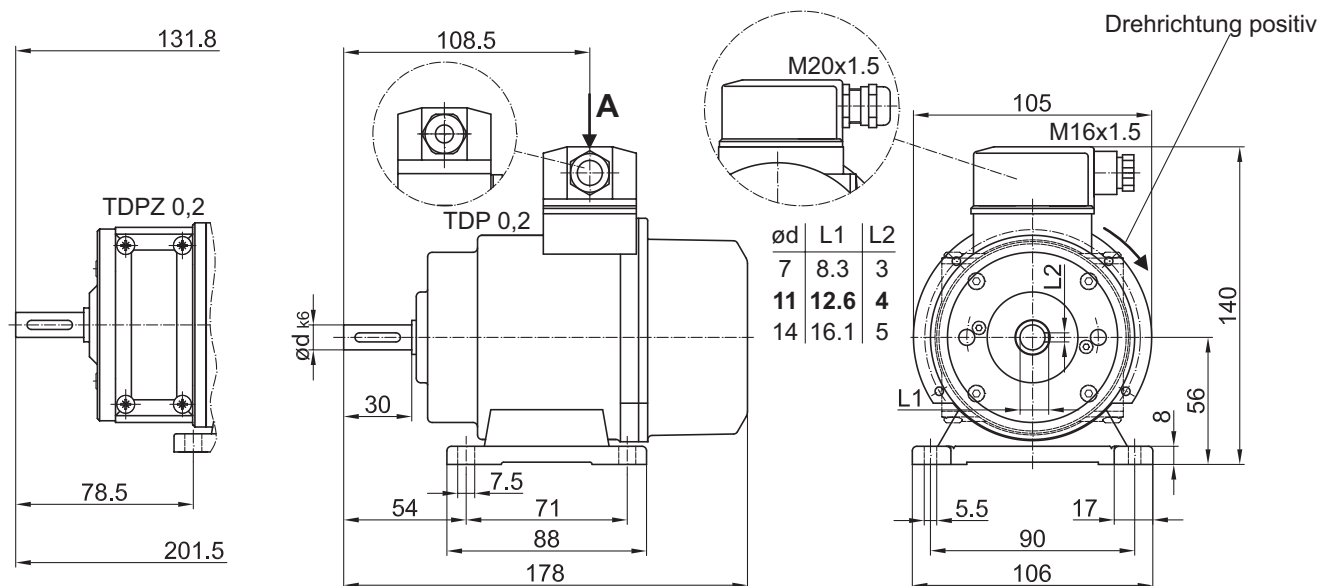

Tachogenerators

Solid shaft with EURO flange B10

With own bearings

TDP 0,2, TDPZ 0,2



TDP 0,2

Technical data - electrical ratings

Reversal tolerance	≤0.1 %
Linearity tolerance	≤0.15 %
Temperature coefficient	±0.05 %/K (open-circuit)
Isolation class	B
Calibration tolerance	±1 %
Climatic test	Humid heat, constant (IEC 60068-2-3, Ca)
Interference immunity	EN 61000-6-2
Emitted interference	EN 61000-6-3

TDP 0,2

Performance	12 W (speed ≥3000 rpm)
Armature-circuit time-constant	<75 μs
Open-circuit voltage	10...150 mV per rpm

TDPZ 0,2

Performance	2x 3 W (speed ≥3000 rpm)
Armature-circuit time-constant	<40 μs
Open-circuit voltage	20...100 mV per rpm

Features

- Low response time
- Open circuit voltage 10...150 mV per rpm
- Redundant output (TDPZ)
- EURO-flange B10 / solid shaft ø11 mm
- Very high resistance to shock
- High signal quality due to patented LongLife technology
- Recognition of sense of rotation possible via control

Optional

- Marine air protected/tropicalized
- Second shaft end (B14) / Housing foot (B3)
- Solid shaft ø7 and ø14 mm

Technical data - mechanical design

Size (flange)	ø115 mm
Shaft type	ø11 mm solid shaft ø7 mm solid shaft (optional) ø14 mm solid shaft (optional)
Flange	EURO flange B10
Protection DIN EN 60529	IP 55, IP 56 (option)
Operating speed	≤10000 rpm
Torque	1.5 Ncm
Shaft loading	≤60 N axial ≤80 N radial
Materials	Housing: aluminium die-cast Shaft: stainless steel
Operating temperature	-30...+130 °C
Resistance	DIN EN 60068-2-6 Vibration 10 g, 10-2000 Hz IEC 60068-2-27 Shock 300 g, 1 ms
Connection	Terminal box

TDP 0,2

Rotor moment of inertia	1.1 kgcm ²
Weight approx.	2.4 kg

TDPZ 0,2

Rotor moment of inertia	1.2 kgcm ²
Weight approx.	2.9 kg

Tachogenerators

Solid shaft with EURO flange B10

With own bearings

TDP 0,2, TDPZ 0,2

Part number

Tachogenerator

TDP0,2LT-

Open-circuit voltage

6	10 mV per rpm
7	20 mV per rpm
10	30 mV per rpm
5	40 mV per rpm
4	60 mV per rpm
3	100 mV per rpm
1	150 mV per rpm

Twin tachogenerator

TDPZ0,2LT-

Open-circuit voltage

7	20 mV per rpm
5	40 mV per rpm
4	60 mV per rpm
3	100 mV per rpm

Data according to type

Type	Open-circuit voltage U_0 [mV/rpm]	Minimum load required depending on speed range [rpm]			Maximum operating speed n_{max} [rpm]	Armature resistance $R_A(20^\circ C)$ [Ω]	Armature inductance L_A [mH]
		0-3000 R_L [k Ω]	0-6000 R_L [k Ω]	0- n_{max} R_L [k Ω]			
TDP0,2LT-6	10	≥ 0.1	≥ 0.3	≥ 0.9	10000	3	6
TDP0,2LT-7	20	≥ 0.3	≥ 1.2	≥ 3.3	10000	11	23
TDP0,2LT-10	30	≥ 0.7	≥ 2.7	≥ 7.5	10000	26	50
TDP0,2LT-5	40	≥ 1.2	≥ 5	≥ 13.5	10000	47	90
TDP0,2LT-4	60	≥ 2.7	≥ 11	≥ 30	10000	99	200
TDP0,2LT-3	100	≥ 7.5	≥ 30	≥ 30	6000	271	550
TDP0,2LT-1	150	≥ 16	---	≥ 30	4000	630	1260

Twin tachogenerator with redundant output
(The data refer to each of the two tachogenerator outputs)

TDPZ0,2LT-7	20	≥ 1.2	≥ 4.8	≥ 14	10000	19	45
TDPZ0,2LT-5	40	≥ 4.8	≥ 20	≥ 54	10000	70	170
TDPZ0,2LT-4	60	≥ 11	≥ 44	≥ 120	10000	160	390
TDPZ0,2LT-3	100	≥ 30	≥ 120	---	6000	445	1080

Superimposed ripple (for $\tau_{RC} = 0.7$ ms): $\leq 0.5\%$ (peak-peak) $\leq 0.2\%$ (rms)

Replacement switching diagram

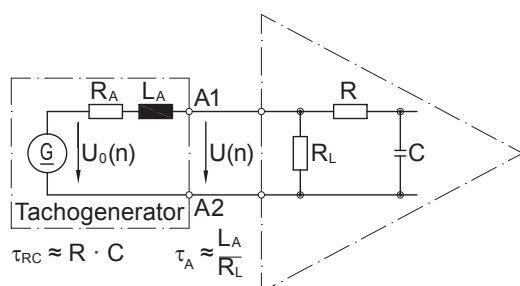

Polarity for positive rotating direction: A1 (TDPZ: 1A1, 2A1): + (VDE)
A2 (TDPZ: 1A2, 2A2): - (VDE)

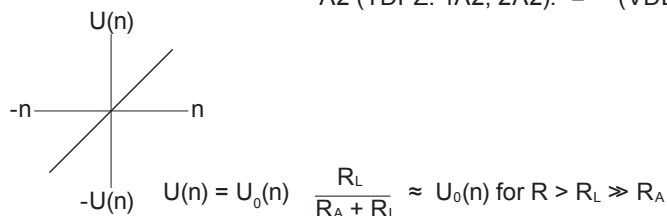

Tachogenerators

Solid shaft with EURO flange B10

With own bearings

TDP 0,2, TDPZ 0,2

Terminal assignment

View A - Connecting terminal TDP 0,2

Polarity for positive direction of rotation

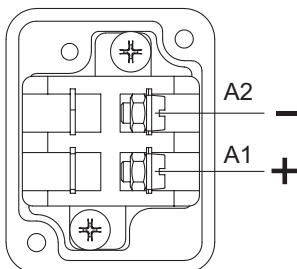

View A - Connecting terminal TDPZ 0,2

Polarity for positive direction of rotation

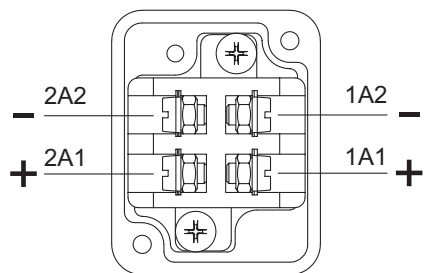

Accessories

Carbon brushes

Mounting accessories

K 35	Spring disk coupling for solid shaft $\varnothing 6...12$ mm
K 50	Spring disk coupling for solid shaft $\varnothing 11...16$ mm
K 60	Spring disk coupling for solid shaft $\varnothing 11...22$ mm

Tachogenerators

Solid shaft with EURO flange B10

With own bearings

TDP 0,2, TDPZ 0,2

Dimensions

TDP 0,2 (TDPZ 0,2) - Version with Euro flange (B10)

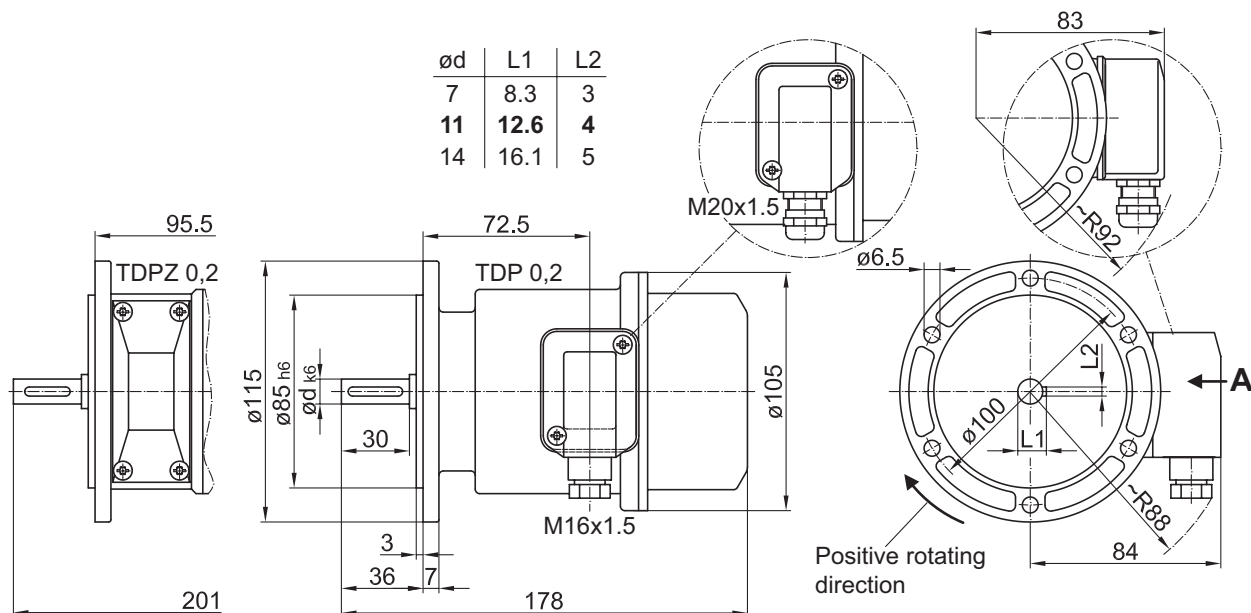

TDP 0,2 (TDPZ 0,2) - Version with housing foot (B3)

