

Gear Pump Units

1-1202-US

For single-line lubrication systems



MFE5-KW3-2



MFE5-BW3-2



MFE5-KW6



MFE5-BW7

These units comprising the **MFE** Group are designed to supply the lubricant used in intermittently operated, single-line centralized lubrication systems. The basic setup includes a gear pump unit with motor, a 3- or 6-liter lubricant reservoir – optionally of metal or plastic – or a 15-liter metal reservoir and float switch to monitor the minimum permissible level of lubricant.

In addition to the basic models it is also possible for the units to be outfitted with add-ons. Special models for a wide variety of applications are listed in the overview table on page 8.

Example of a single-line central lubrication system for automobile makers

The system consists essentially of:

- a gear pump unit
- 6-liter metal reservoir
- piston distributors, assembly 340
- metering units, assembly 320
- pressure switches, group DS-W for max. pressure build-up and relief pressure

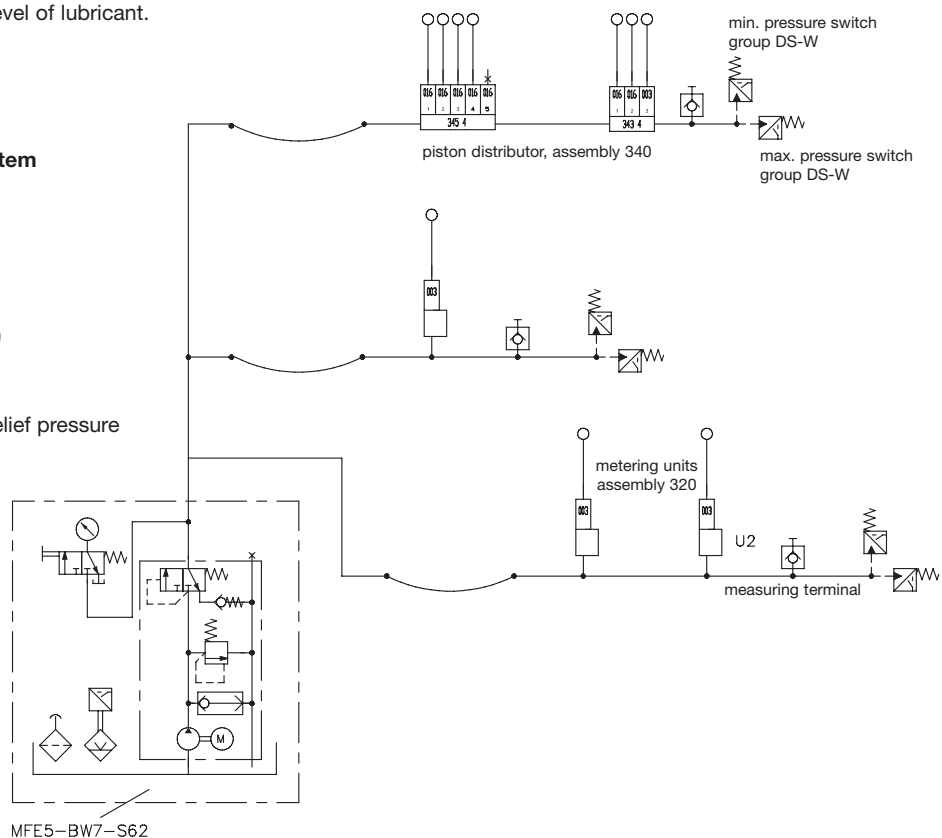

Model ME5 Gear pump unit mounted separate from oil reservoir

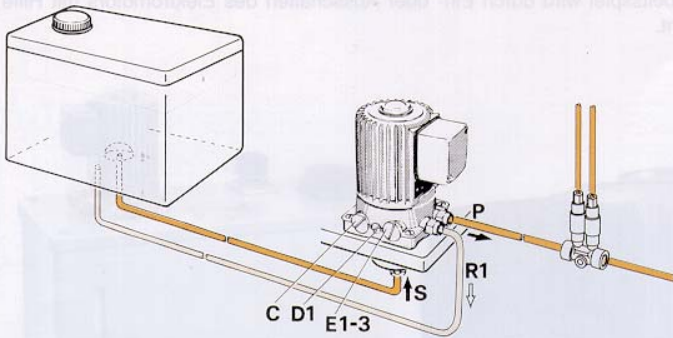

Fig. 1

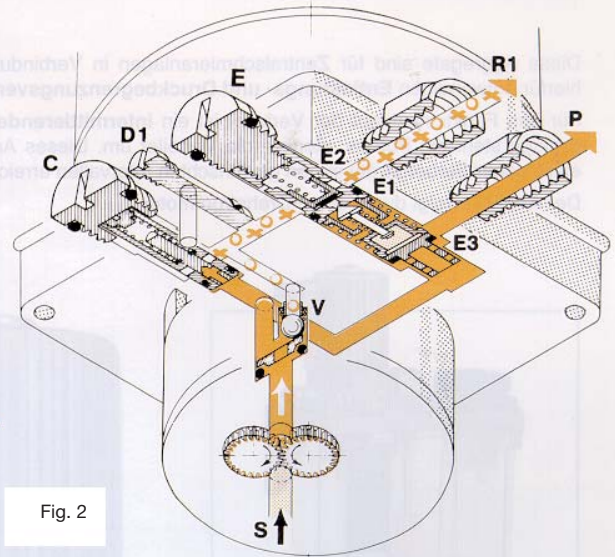

Fig. 2

Model MFE5 Gear pump unit for flange-mounting on oil reservoir

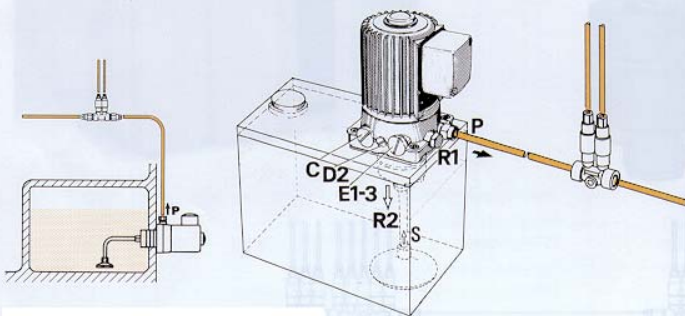

Fig. 3

Fig. 4

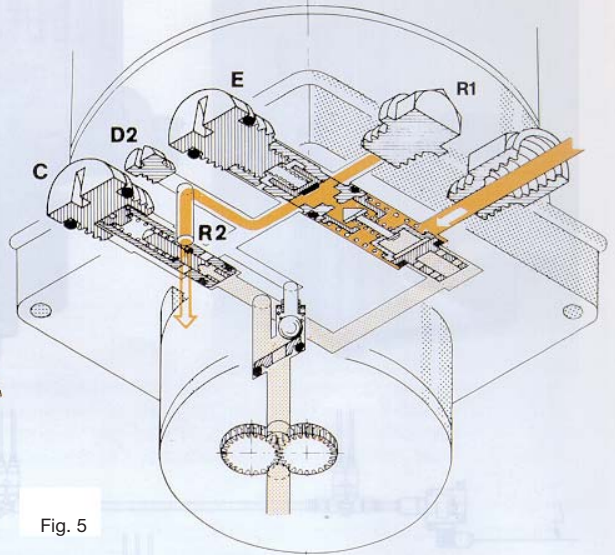
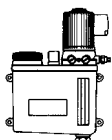

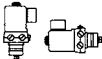

Fig. 5

Regarding Fig. 3:

A special sealed pump must be used for horizontal flange-mounting of the unit in a position **below the oil level**.



Gear pump unit model **MFE5** complete with metal or plastic reservoir (3, 6 and 15 liters) see pages 5-7.

Order No. 1)	Model	Mounting position
ME5	mounted separate from oil reservoir	
MFE5	for flanging to oil reservoir	

1) Please quote voltage and frequency when ordering.

Notice!

All products from VOGEL may be used only for their intended purpose. If operating instructions are supplied together with the products, the provisions and information therein of specific relevance to the equipment must be observed as well.

In particular, we call your attention to the fact that hazardous materials of any kind, especially the materials classified as hazardous by EC Directive 67/548/EEC, Article 2, Par. 2, may only be filled into VOGEL centralized lubrication systems and components and delivered and/or distributed with the same after consultation with and written approval from VOGEL.

All products manufactured by VOGEL are not approved for use in conjunction with gases, liquefied gases, pressurized gases in solution and fluids with a vapor pressure exceeding normal atmospheric pressure (1013 mbars) by more than 0.5 bar at their maximum permissible temperature.

Explanation of hydraulic function

Both types have the same hydraulic function.

Oil is sucked in at **S** and flows under pressure through the duct in the direction **P**. The oil pressure closes valve **V** and opens valve **E3**, at the same time closing valve **E1** against spring tension. If air is entrained (due to low oil level in the reservoir), valve **V** remains open and diverts the air or, respectively, the air-oil mixture into the return duct (see bubble (o) marking in direction **R1**). Valve **C** allows oil under overpressure to flow out into the return duct (see cross (+) marking).

When the unit stops (interval time), spring-loaded valve **E1** opens and valve **E3** simultaneously closes. The system pressure at **P** can now be released through valve **E1** – with the exception of a small amount of residual pressure determined by valve **E2**. This pressure release is required for the piston distributors to function correctly.

The pressure relief process is shown in Fig. 5.

Explanation of the structural differences

In the case of model **ME5**, the long screw plug **D1** blocks flanged port **R2** of the return duct. The oil returning from valves **V**, **C** and **E1** flows via port **R1** through a tube to the separately mounted oil reservoir (see Fig. 1 and 2).

In the case of model **MFE5**, the short screw plug **D2** – unlike **D1** with model **ME5** – leaves flanged port **R2** open. A plug closes off external port **R1**. – Flanged port **R2** of the return duct drains directly into the reservoir without any connection threads (see Fig. 4 and 5).

MFE5 unit variants

Order No.	Flow rate ³⁾ [l/min]	Max. back pressure ⁴⁾ [bars]	Design
MFE5	0.5	27	basic version
MFE5-D	0.5	27	installed below oil level
MFE5-K	0.5	16	operation with capacitors
MFE5-S8	0.5	27	basic version, FPM
MFE5-S9	0.5	16	for oil as of 5 mm ² /s
MFE5-S29	0.5	27	50/95 weatherproofing (acc. DIN 50015)
MFE5-S40	0.5	27	HAN6ES Harting connector
MFE5-S41	0.5	27	UL-approved
MFE5-S43	0.5	27	for oil as of 5 mm ² /s, UL
MFE5-S53	0.5	27	FPM, for oil as of 5 mm ² /s

Permissible operating viscosity 20 bis 1000 mm²/s
 Max. suction head 500 mm
 Weight ≈ 3 kg

Three-phase motor

Voltage 230/400 V ⁵⁾ Power consumption 0.29 A
 Frequency 50 Hz Rated power 0.07 kW
 (Please specify different voltages Speed 2700 rpm
 or frequencies required when Duty cycle 100%
 ordering) Type of enclosure IP 54

Running capacitors of Steinmetz circuit
 at a frequency of 50/60 Hz: 230 V ... 8 µF, 115 V ... 30 µF

Special units are available on request for oils with operating viscosities outside the permissible values. Please inquire.

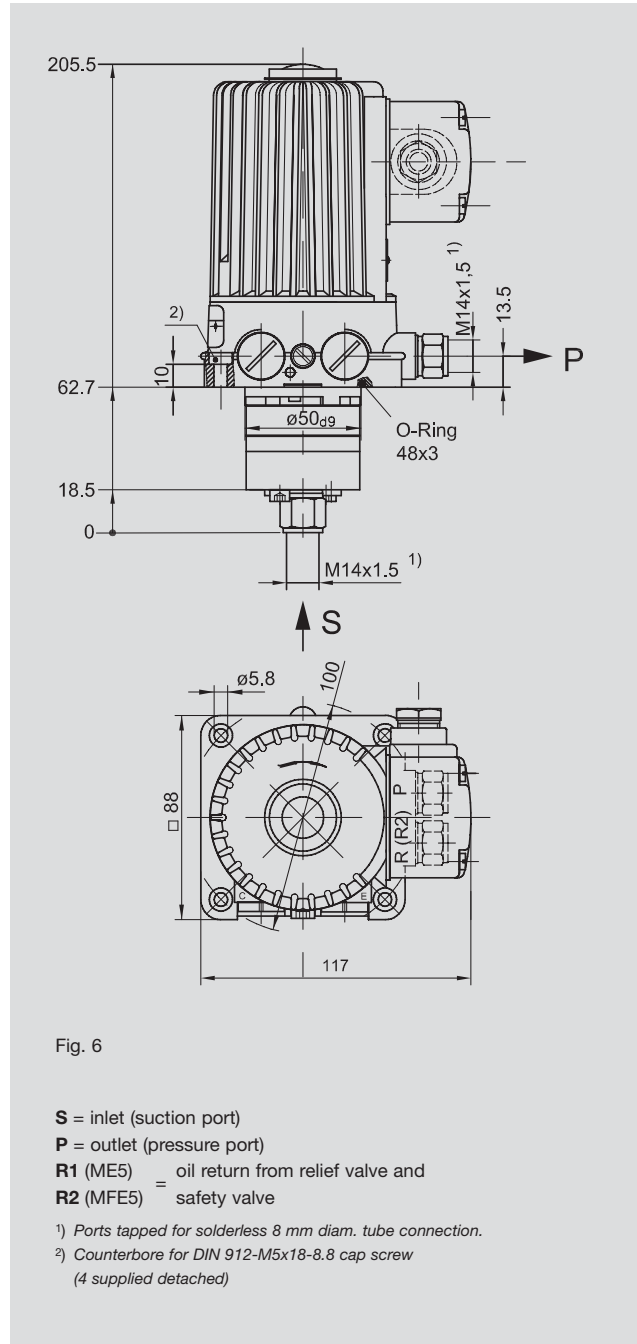

Fig. 6

S = inlet (suction port)
P = outlet (pressure port)
R1 (ME5) = oil return from relief valve and
R2 (MFE5) = safety valve

¹⁾ Ports tapped for solderless 8 mm diam. tube connection.
²⁾ Counterbore for DIN 912-M5x18-8.8 cap screw
 (4 supplied detached)

³⁾ Flow rate based on an operating viscosity of 140 mm²/s at a back pressure of p = 5 bars.

⁴⁾ The max. back pressure is equivalent to the actual value of the built-in safety valve.

If the units are operated with a single-phase AC supply, only 60% of the indicated pressure is permissible, i.e. a 16-bar safety valve should be fitted to the system.

The appropriate capacitors for a frequency of 50 and 60 Hz are:

230 V ... 8 µF: order No. **179-340-007**
 115 V ... 30 µF: order No. **179-340-060**

⁵⁾ See page 4: "Multivoltage motors".

Multivoltage motors for pump units (assembly M..)

Many export-oriented companies have to deal with voltages/frequencies that deviate from those in Germany. To make it easier for them to buy the most common pump units for centralized lubrication systems we have developed **3 multirange motors that cover a wide range of three-phase voltages and frequencies.**

Pump units with or without oil reservoirs are included, **provided the hydraulic power data listed in the leaflets are not exceeded** (limit values).

They are the following units:

M2, MF2, MFE2, M5, MF5, MFE5, FLM12-3, FLMF12-3, M202

Limit values for

- 0,2 l-units (M..2-Group): 27 bars – 2000 mm²/s eff.
- 0,5 l-units (M..5-Group): 27 bars – 1000 mm²/s eff.
- 1,2 l-units FLM12-3: 6 bars – 850 mm²/s eff.
- 2x0.2 l-units M202: 12 bars – 850 mm²/s eff.

Our experience shows they can meet almost every need. That means simplified warehousing for our customers and shorter delivery times, since we always have these 3 types of motors in stock.

The rating plate on multirange motors is green

It shows the respective voltage ranges and rated speeds for 50 and 60 Hz separately as well as the permissible power consumption throughout the entire range.

No voltage tolerances ($\pm 5\%$) have to be allowed for with multirange motors conforming to EN 60 034, i.e. the indicated range limit values have to be taken as maximum or minimum limit values respectively.

Range I



100-130 V / 173-225 V, 50 Hz
120-156 V / 208-270 V, 60 Hz
 order code: **199**
 order code ISO-F: **19E**

Range II



207-254 V / 360-440 V, 50 Hz
249-305 V / 432-528 V, 60 Hz
 order code: **299**
 order code ISO-F: **29E**

Range III



230-290 V / 398-500 V, 50 Hz
290-346 V / 500-600 V, 60 Hz
 order code: **399**
 order code ISO-F: **39E**

A tailor-made motor has to be used instead of a multirange motor in the following cases:

- a) when the desired operating voltage cannot be covered by one of the three voltage ranges,
- b) when the operating voltage, with the voltage tolerances to be expected, exceeds a defined voltage benchmark for the range,
- c) when CSA motors are involved,
- d) in the case of motors with double-star windings (YY),
- e) in the case of motors with PTC thermistor sensors,
- f) in the case of units (e.g. M1 or M201) outfitted with a 4-pole motor,
- g) for the M205 dual-circuit pump unit.

The rating plate on tailor-made motors is red

Example:

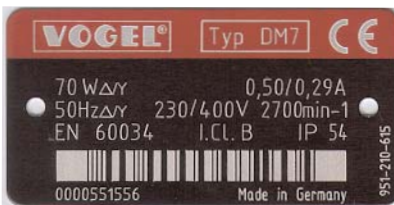

Voltage	Order key
230/400 V, 50 Hz	140
230/400 V, 50 Hz, ISO-F	143
230/400 V, 60 Hz	640
230/400 V, 60 Hz, ISO-F	621
240/415 V, 50 Hz	150
240/415 V, 50 Hz, ISO-F	152
240/415 V, 60 Hz	650
240/415 V, 60 Hz, ISO-F	586
255/440 V, 50 Hz	165
255/440 V, 50 Hz, ISO-F	181
255/440 V, 60 Hz	665
255/440 V, 60 Hz, ISO-F	831
265/460 V, 50 Hz	175
265/460 V, 60 Hz	675
265/460 V, 60 Hz, ISO-F	674
265/460 V, 60 Hz, UL	563
265/460 V, 60 Hz, CSA	676
280/480 V, 60 Hz	680
280/480 V, 60 Hz, ISO-F	699
280/480 V, 60 Hz, UL	562
280/480 V, 60 Hz, CSA	681
280/480 V, 60 Hz, UL/CSA	564
115 V, 50 Hz	257
115 V, 60 Hz	757
230 V, 50 Hz	263
230 V, 60 Hz	763
115 V, 50/60 Hz	429
230 V, 50/60 Hz	428
100-120 V, 50/60 Hz, 200-240 V, 50/60 Hz	471
20-24 V DC, 20-24 V, 50/60 Hz	472
12 V DC	912
24 V DC	924
48 V DC	931

MFE5 gear pump unit with 3 or 6-liter metal reservoir



Order No.	Flow rate [l/min]	Reservoir capacity [liters]	Reservoir material	Order No. without float switch
MFE5-BW3-2	0.5	3	die-cast aluminum	MFE5-B3-2
MFE5-BW7	0.5	6	sheet steel	MFE5-B7

Port **P** tapped for solderless tube connection, M14x1.5 for 8 mm diam. tube.
See page 3 for further technical details.

Technical data

Float switch for monitoring of critical oil level

Type of contact	1 changeover
Max. switching voltage	230 V AC / 230 V DC
Max. switching current	1.0 A
Max. switching capacity	60 VA / 40 W 1)
Type of enclosure	IP 65
Temperature range	- 10 °C to + 80 °C

1) Take appropriate measures to protect contacts when switching inductive loads.

Circuit diagram

Float switch

Function:

When the oil drops to a minimum level, contact 1-2 opens and contact 1-3 closes.

With plug-type connector to DIN 43650-AM 3

Depicted: full reservoir

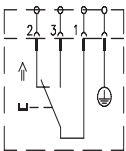

Hydraulic layout

MFE5-BW3-2 / MFE5-BW7 (units with WS float switch)

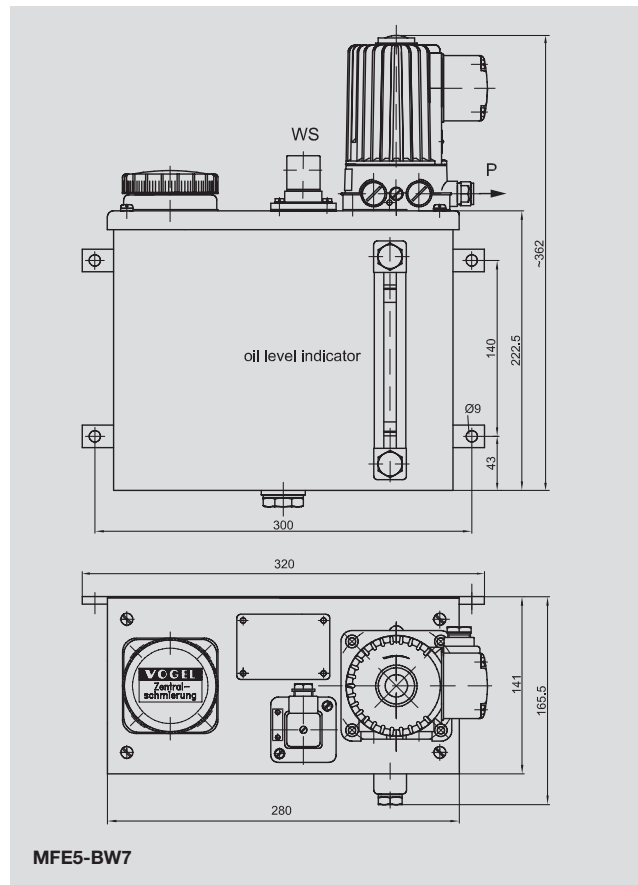
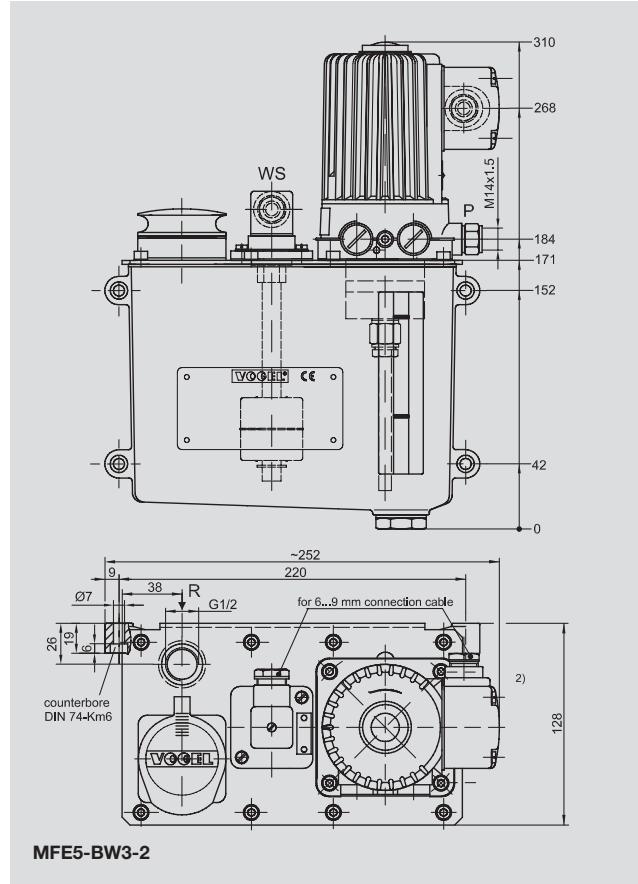
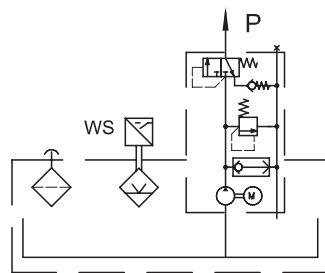

MFE5 gear pump unit with 3 or 6-liter plastic reservoir



Order No.	Flow rate [l/min]	Reservoir capacity [liters]	Reservoir material	Order No. without float switch
MFE5-KW3-2	0.5	3	plastic	MFE5-K3-2
MFE5-KW6	0.5	6	plastic	MFE5-K6

Port **P** tapped for solderless tube connection, M14x1.5 for 8 mm diam. tube.
See page 3 for further technical details.

See page 5 for technical data on the float switch.

Hydraulic layout

MFE5-K3-2 / MFE5-K6
(Units without float switch)

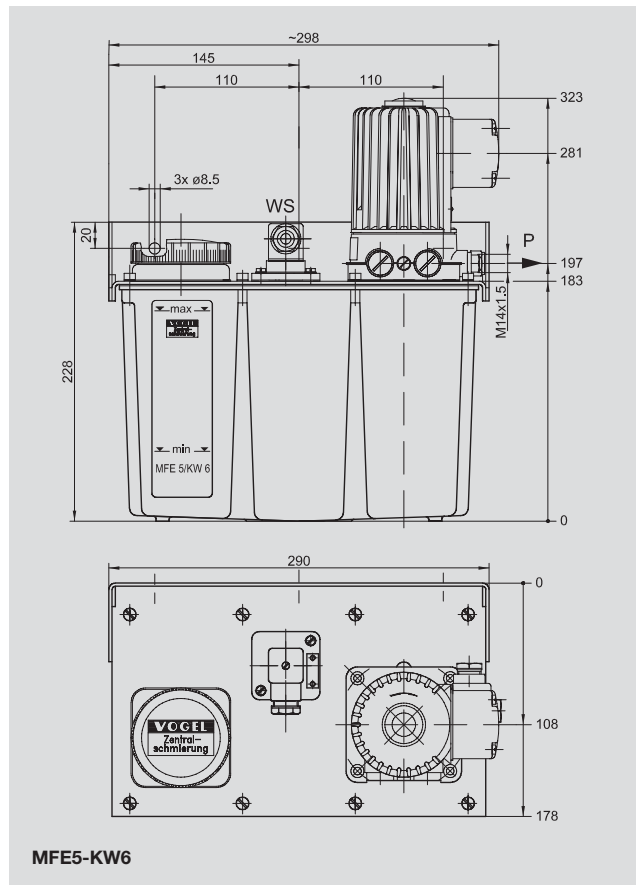
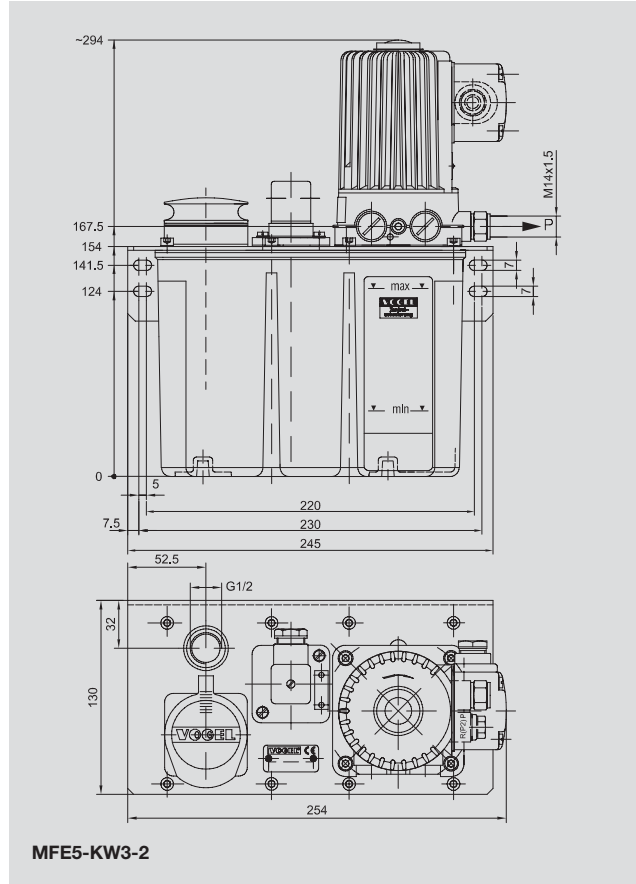
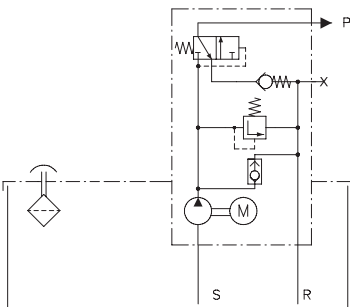

MFE5 gear pump unit with 15-liter sheet steel reservoir



Order No.	Flow rate [l/min]	Reservoir capacity [liters]
MFE5-BW16	0,5	15

Port **P** tapped for solderless tube connection, M14x1.5 for 8 mm diam. tube.
See page 3 for further technical details.

Technische Daten

Float switch

to monitor the critical level of oil with advance warning about 25 mm before the minimum oil level is reached.

- Type of contact 2 NC types (reed contacts)
- Max. switching voltage 230 V AC / 230 V DC
- Max. switching current 0.8 A
- Max. switching capacity 60 VA / 30 W 1)
- Type of enclosure IP 65
- Temperature range - 10 °C to + 80 °C

1) Take appropriate measures to protect contacts when switching inductive loads.

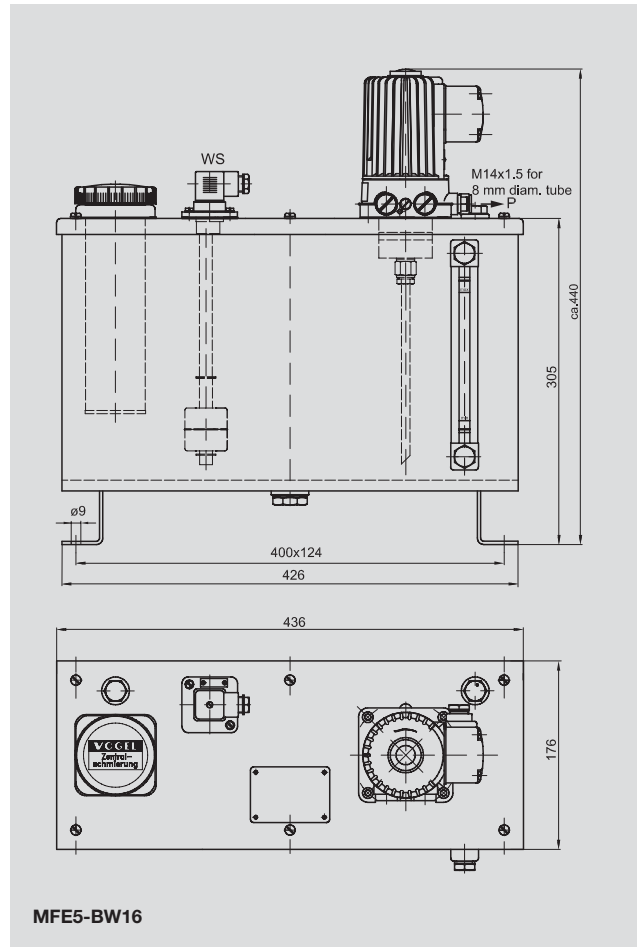

Circuit diagram

Float switch

With plug-type connector to DIN 43650-AM 3

Depicted: full reservoir

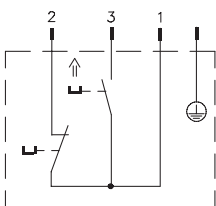

Function:
About 25 mm before the critical oil level is reached contact 1-3 closes.
When the critical oil level is reached contact 1-2 opens in addition.

Hydraulic layout

MFE5-BW16

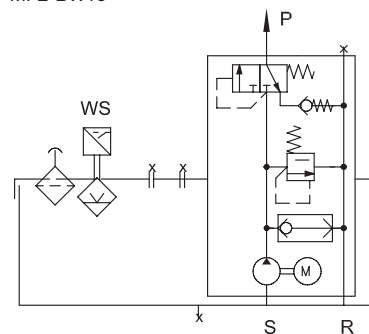

Bracket for wall mounting, order No. 249-032.10

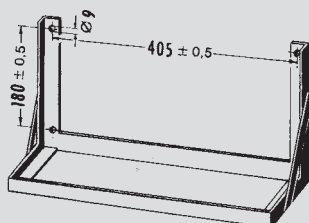

Overview table for gear pump units

Order No.	Reservoir capacity [liters]	Reservoir material	Design features
MFE5-KW3	3	Plastic	Basic version with WS32-2 float switch contact tube
MFE5-KW3-2-S4	3	Plastic	Basic version with WS35-2 float switch
MFE5-KW3-S9	3	Plastic	For oil as 5 mm ² /s at max. 16 bars
MFE5-KW3-2-S12	3	Plastic	VW version with WS35-S14 float switch (2x NC contacts)
MFE5-KW3-S13	3	Plastic	Unit for 50/95 weatherproofing, float switch WS32-2
MFE5-KW3-S24	3	Plastic	DaimlerChrysler version (Desina); WS35-S30 float switch; Motor with HAN6ES Harting connector
MFE5-BW3	3	Metal	Basic version with WS32-2 float switch contact tube
MFE5-BW3-S14	3	Metal	French Automotiv version (CNOMO); WS35 float switch contact tube; Stäubli filler coupling
MFE5-BW3-S22	3	Metal	For oil as 5 mm ² /s at max. 16 bars
MFE5-BW3-S28	3	Metal	VW-AG version, WS35-S14 float switch (2x NC contacts)
MFE5-BW3-K-S33	3	Metal	Version for operation with capacitors at max. 16 bars
MFE5-BW3-S34	3	Metal	Motor with UL approval
MFE5-BW3-S35	3	Metal	Motor for 50/95 weatherproofing
MFE5-BW3-S37	3	Metal	Basic version with WS35-3 float switch contact tube
MFE5-BW3-S41	3	Metal	DaimlerChrysler version (Desina); WS35-S30 float switch; Motor with HAN6ES Harting connector
MFE5-KW6	6	Plastic	Basic version with WS32-2 float switch
MFE5-KW6-S1	6	Plastic	Basic version with WS35-2 float switch
MFE5-KW6-S8	6	Plastic	FPM version, WS32-S8 float switch
MFE5-KW6-S24	6	Plastic	Version for VW-AG with pressure gauge, protection valve, WS35-S7 float switch (2x NC contacts)
MFE5-KW6-S33	6	Plastic	DaimlerChrysler version (Desina); motor with HAN6ES Harting connector; WS35-S30 float switch with M12x1 plug connector
MFE5-BW7	6	Metal	Basic version with WS32-2 float switch
MFE5-BW7-CF	6	Metal	Basic version with WS35-2 float switch
MFE5-BW7-S8	6	Metal	FPM version, WS32-S8 float switch
MFE5-BW7-S22	6	Metal	Motor with UL approval
MFE5-BW7-S29	6	Metal	French Automotiv version (CNOMO); WS35-2 float switch; Stäubli filler coupling
MFE5-BW7-S54	6	Metal	Motor with enhanced 50/95 weatherproofing
MFE5-BW7-S62	6	Metal	Version for VW-AG with pressure gauge, protection valve, WS35-S7 float switch (2x NC contacts)
MFE5-BW7-S98	6	Metal	Version like MFE5-BW7-S62, but additionally with filler coupling
MFE5-BW7-S107	6	Metal	DaimlerChrysler version (Desina); motor with HAN6ES Harting connector; WS35-S30 float switch with M12x1 plug connector
MFE5-BW7-V57-L	6	Metal	GM - OPEL version with 10 µm pressure filter, WS35-S30 float switch with M12x1 plug connector, EO2 screw unions
MFE5-BW15	15	Metal	Basic version with WS32-2 float switch; wall-mounted reservoir
MFE5-BW16	15	Metal	Basic version with WS32-2 float switch; foot-mounted reservoir
MFE5-BW15-S7	15	Metal	Basic version with WS35-2 float switch; wall-mounted reservoir
MFE5-BW16-S3	15	Metal	For oil as 5 mm ² /s at max. 16 bars; foot-mounted reservoir; FPM version, WS35-S8 float switch
MFE5-BW16-S5	15	Metal	For oil as 5 mm ² /s at max. 16 bars; foot-mounted reservoir
MFE5-BW16-S46	15	Metal	Version for VW-AG; foot-mounted reservoir; with WS35-S7 float switch (2x NC contacts); pressure gauge with protective valve
MFE5-BW16-S93	15	Metal	DaimlerChrysler version (Desina); foot-mounted reservoir; motor with HAN6ES Harting connector; WS35-S30 float switch with M12x1 plug connector
MFE5-BW16-V57L	15	Metal	GM / OPEL version; foot-mounted reservoir; 10 µm pressure filter; WS35-S30 float switch with M12x1 plug connector, EO2 screw unions



Willy Vogel AG
 Motzener Strasse 35/37
 12277 Berlin, Germany
 P.O. Box 970444 · 12704 Berlin
 Tel. +49 (0) 30 - 720 02-0
 Fax +49 (0) 30 - 720 02-111
 info@vogel-berlin.de
 www.vogelag.com

Willy Vogel AG
 2. Industriestrasse 4
 68766 Hockenheim
 Germany
 Tel. +49 (0) 62 05 - 27-127
 Fax +49 (0) 62 05 - 27-101
 info@vogel-berlin.de
 www.vogelag.com

Vogel France SAS
 Rue Robert Amy, B.P. 130
 49404 Saumur cedex
 France
 Tel. +33 (0) 241 404 200
 Fax +33 (0) 241 404 242
 info@vogelfrance.com
 www.vogelfrance.com