

Technical Manual

digiVEC

AC Servo Inverter (Vector Control)

for synchronous and asynchronous motors

27. June 1998

© **Copyright**

No text, drawings or other parts of this manual may be reproduced, copied or otherwise duplicated without written permission from **Contraves Antriebstechnik GmbH, 55124 Mainz-Gonsenheim, Germany**.

Safety and Application Instruction for Drive Converters

(According to the Low Voltage Directive 73/23/EU)

1. General

During operation, drive converters of this type include parts carrying live voltages as well as bare, moving or rotating parts and hot surfaces.

There is a risk of severe personal injury or property damage if guards or covers are removed or the unit is installed or operated incorrectly.

Further information is provided in this manual.

All work on transportation, installation, commissioning and maintenance is to be carried out by qualified specialist personnel (IEC 364 or CENELEC HD 384 respectively, DIN VDE 0100 and IEC Report 664 or DIN VDE 0110 and national accident prevention regulations are to be observed).

Qualified personnel in the sense of these fundamental safety instructions are personnel familiar with and qualified in installation, assembly, commissioning and operation of the product.

2. Correct use

Drive converters are components intended for installation in electrical plant or machinery.

When installed in machines, commissioning the drive converter (i.e. commencement of operation) is prohibited until it is certain the machine complies with EC directive 89/392/EC (Machine Directive). EN 60204 is to be observed.

Commissioning (i.e. commencement of operation) is only permitted on compliance with the EMC directive (89/336/EC).

Drive converters meet the requirements of the low voltage directive 73/23/EC. The harmonised standards of the series prEN50178/DIN VDE 0160 in conjunction with EN 60439-1/DIN VDE 0660 Part 500 and EN 60164/DIN VDE 0558 are also applicable to drive converters.

The technical data and connection details are shown on the rating plate and in the documentation and must be observed.

3. Transportation, storage

The notes on transportation, storage and correct handling must be observed.

Climatic conditions are to be maintained according to prEN 50178.

4. Installation

Installation and cooling for the units must comply with the regulations stated in the relevant documentation.

Drive converters are to be protected against excessive stress. In particular no components may be bent and/or insulation spacings altered during transport and handling. Avoid touching electronic components and contacts.

Drive converters contain components which are easily damaged by static electricity or incorrect handling. Electrical components may not be mechanically damaged or destroyed (under certain circumstances this may cause a risk to health!).

5. Electrical connection

When working on drive converters when they are "live" the applicable national safety regulations (e.g. VBG 4) are to be observed.

The electrical installation is to be carried out in accordance with the appropriate regulations (e.g. cable cross-sections, fuses, protective conductor connections). Additional instructions are given in the documentation.

Notes on correct EMC installation - such as screening, earthing, the position of filters and cable runs - are given in the documentation for the drive converters. These instructions are also to be observed when using drive converters carrying the CE mark. The system or machine manufacturer is responsible for compliance with the limits specified in EMC legislation.

6. Operation

Equipment in which drive converters are installed must if applicable be fitted with additional monitoring and protection devices according to the relevant safety regulations, for example the technical equipment law, accident prevention regulations etc. Modification of drive converters using the operating software is permitted.

When the drive converter is isolated from the supply voltage any parts of the unit and any power contacts which may carry voltages may not be touched immediately, as capacitors retain their charge for a certain time. Always note the appropriate warning signs and labels etc. on the converter.

All covers and doors are to remain closed during operation.

7. Maintenance and service

Note the manufacturer documentation.

These safety instructions must be kept available in a safe place!
Also note the product-specific safety and application instructions in this manual

CONTENTS

1. Safety instructions	9
2. System introduction	11
2.1. Brief description	11
2.2. Front view	13
2.3. Block circuit diagram	15
2.4. Unit description	17
2.4.1. Three-phase bridge rectifier with subsequent voltage link	18
2.4.2. Feedback facilities	19
2.4.3. Parameters on the individual multiplexers	20
2.4.4. Other parameters:	23
2.4.5. Control: Position, Speed, Current controller	25
2.4.6. Coordinates transformation, pulse width modulation	29
2.4.7. Memory areas	30
2.4.8. Encoder simulation (optional)	31
2.5. Intended use	32
3. Technical data	33
3.1. Ambient conditions	34
3.2. Performance overview	35
3.3. Input test	35
3.4. CE Declaration of Conformity	37
4. Installation	39
4.1. digiVEC monitor program	39
4.1.1. Program installation	39
4.1.2. Running the monitor program	40
4.1.3. Menu overview, digiVEC user interface (German version)	43
4.1.4. Using the configuration program	44

4.1.5. Using the Help system	45
4.2. <i>General wiring guidelines</i>	47
4.3. <i>Motor and power connections</i>	49
4.3.1. Screening and interference suppression	49
4.3.2. Cubicle installation	50
4.3.3. Motor connection	51
4.3.4. Power connections	52
4.3.5. Supply cable cross-sections for mains and motor connection:	53
4.3.6. Mains filters, filters for controller electronics supply voltage	54
4.4. <i>Signal leads</i>	55
4.5. <i>External braking resistors</i>	56
4.6. <i>External supply voltage</i>	57
4.7. <i>Fuses in electronic circuits</i>	58
4.8. <i>Feedback systems</i>	59
4.8.1. Resolver connection	59
4.8.2. Encoder connection	60
4.8.2.1. Encoder supply	61
4.8.3. Wiring of terminal strip X1:	62
4.8.4. Analog inputs and outputs	63
4.8.4.1. Differential analog inputs	63
4.8.4.2. Unipolar analog input	64
4.8.4.3. Analog outputs	65
4.8.5. Digital inputs and outputs	66
4.8.5.1. Digital inputs:	66
4.8.5.2. Digital outputs	68
4.8.6. Serial interfaces	70
4.8.6.1. Connection for RS485 network: Plug X3H	70
4.8.6.2. Connection for PC, RS232 at plug X3L	72

5. Commissioning	73
5.1. Running the digiVEC configuration program	75
5.2. Setting motor parameters	76
5.2.1. POLE_SHIFT	76
5.2.2. BASE_SPEED	77
5.2.3. Speed limit	77
5.3. Motor matching	79
5.3.1. Asynchronous motor	79
5.3.2. Synchronous motor	82
5.3.3. Calibrate speed controller	84
5.3.3.1. Calibrate NGAIN_NOM of speed controller (without applying demand)	84
5.3.3.2. Calibrate NGAIN_NOM of speed controller (with demand applied):	85
5.3.4. Fine calibration of NTAU for speed controller	86
5.4. Demand scaling	87
5.5. Drive response to errors	89
5.5.1. Function of LEDs on digiVEC front panel	90
5.5.2. Errors during operation	92
5.5.3. Operating conditions	93
5.5.4. Test points on unit	94
5.6. digiVEC operating parameters	95
5.7. Function of individual flags	103
6. Jumper	109
6.1. Jumper setting	109
6.2. Jumper locations on DAM card	111
7. Installation dimensions	113
7.1. Installation dimensions for DAC4, DAC7 and DAC11	113
7.2. Installation dimensions for DAC18 and DAC28	113

<i>7.3. Installation dimensions for DAC60 and DAC80</i>	<i>114</i>
<hr/>	
8. Motor connection wiring	115
<hr/>	
<i>8.1. ACD synchronous motors</i>	<i>115</i>
<hr/>	
<i>8.1.1. Using plug connector</i>	<i>115</i>
<hr/>	
<i>8.1.1.1. Series: ACD 07, ACD 09, ACD 11</i>	<i>115</i>
<hr/>	
<i>8.1.1.2. Series: ACD 14, ACD 19</i>	<i>116</i>
<hr/>	
<i>8.1.2. With terminal box</i>	<i>117</i>
<hr/>	
<i>8.1.3. Connection for brake (every ACD series)</i>	<i>118</i>
<hr/>	
<i>8.2. CAS asynchronous motors</i>	<i>119</i>
<hr/>	
<i>8.2.1. With terminal box</i>	<i>119</i>
<hr/>	
<i>8.2.2. With plug connector</i>	<i>120</i>
<hr/>	
<i>8.3. CAD asynchronous motors</i>	<i>122</i>
<hr/>	
9. Information for ordering	127
<hr/>	
<i>9.1. Cables and plug connectors</i>	<i>127</i>
<hr/>	
<i>9.2. Mains filters, filters for controller electronics supply voltage</i>	<i>129</i>
<hr/>	
<i>9.3. Address for orders</i>	<i>130</i>
<hr/>	
10. Index	131
<hr/>	
11. Space for notes	133

List of illustrations

Fig. 2.2-1 Front view	13
Fig. 2.3-1 Block circuit diagram	Fehler! Textmarke nicht definiert.
Fig. 2.4-1 Application	20
Fig. 2.4-2 Pulse width modulation	29
Fig. 2.4-3 Wiring of encoder output plug X4H	31
Fig. 2.4-4 Jumper setting	31
Fig. 4.1-1 User interface, standard profile	44
Fig. 4.1-2 Example, Help system	45
Fig. 4.3-1 Screening and interference suppression	49
Fig. 4.3-2 Contacting, cable screen	51
Fig. 4.6-1 Basic circuit diagram, external supply voltage	57
Fig. 4.8-1 Connection for resolver	59
Fig. 4.8-2 Connection for encoder	60
Fig. 4.8-3 Basic connection, encoder supply	61
Fig. 4.8-4 Basic circuit diagram, differential analog inputs	63
Fig. 4.8-5 Basic circuit diagram, unipolar analog input	64
Fig. 4.8-6 Function of analog outputs	65
Fig. 4.8-7 Basic circuit diagram, digital inputs	66
Fig. 4.8-8 Basic circuit diagram with time measurement markers at TTL level	67
Fig. 4.8-9 Basic circuit diagram, digital input X1:37	67
Fig. 4.8-10 Basic circuit diagram, digital outputs	69
Fig. 4.8-11 Basic circuit diagram, synchronisation clock	69
Fig. 4.8-12 Multiple drive operation	70
Fig. 4.8-13 Connection cable	72
Fig. 5.3-1 NGAIN_NOM	85
Fig. 5.5-1 LEDs	89
Fig. 5.5-2 Test points	94
Fig. 6.2-1 Jumpers on DAM card	111
Fig. 7.1-1 Installation dimensions: DAC 4, 7, 11	113
Fig. 7.2-1 Installation dimensions: DAC 18, 28	113
Fig. 7.3-1 Installation dimensions: DAC 45, 60, 80	114
Fig. 8.1-1 Motor plug ACD 07/09/11	115
Fig. 8.1-2 Motor plug ACD 14/19	116
Fig. 8.1-3 Terminal box, ACD motors	117
Fig. 8.1-4 Brake, ACD motors	118
Fig. 8.2-1 Terminal box, CAS motors	119
Fig. 8.2-2 Fan plug	120
Fig. 8.2-3 Motor plug, CAS motors	121
Fig. 8.2-4 Plug connector for thermal switch	121
Fig. 8.3-1 Terminal box CAD 71	122
Fig. 8.3-2 Terminal box CAD 80/90	123
Fig. 8.3-3 Fan connection	123
Fig. 8.3-4 Terminal box CAD 100	124
Fig. 8.3-5 Fan connection	124
Fig. 8.3-6 Circuit diagram, terminal box CAD 112	125
Fig. 8.3-7 Fan connection	125

1. Safety instructions

The *digiVEC* unit is designed in accordance with the latest safety conditions (VBG 4) and provides a high level of personnel protection against accidental contact.

When drive systems are operated and maintained correctly there will normally be no risk to property or the health of operator personnel. However, components and equipment such as motors etc. may cause risks if the complete system or machine is not designed, installed, maintained and operated correctly, the instructions given in this operating manual are not observed and unqualified personnel make unauthorised modifications.

The safety conditions and restrictions on use stated below are intended to protect both personnel and equipment and must therefore be strictly observed:

- The user is responsible for ensuring that the motor, the *digiVEC* converter and any additional equipment are installed and connected correctly in accordance with the appropriate technical regulations. Particular attention is to be paid to the rating of cables, fuses, earthing, shutdown, isolation and the overcurrent contactor.
- All local regulations must be observed.
- All work on the unit may only be carried out by suitably trained specialist technicians.
- All work on the unit may only be carried out using suitable tools.
- All work on the power connections of power amplifiers and motors may only be carried out with the unit isolated (fuses removed).
- All technical safety equipment on the machine being controlled is to be designed and installed so that it operates independently of the control itself. Emergency-off equipment must remain operational in all control modes of operation.
- Suitable safety measures are required for connecting the I/Os (inputs and outputs) on both the hardware and software sides to ensure that a wire break on the signal side cannot result in any unspecified condition in the control.
- No ancillary cards or plugs may be inserted or removed while the voltage is present.

If the safety regulations and restrictions on use are not strictly observed there can be a risk of:

- Accident through uncontrolled movement of parts, motors or machines.
- Destruction of the unit or parts thereof.
- Destruction of other components such as motors, machines etc.
- Electricity flowing through the human body (electric shock can be fatal).

<u>Attention!</u> All liability is excluded if the above conditions are not observed!
--

2. System introduction

2.1. Brief description

Variables:

Digital VECtor-controlled AC inverters of the *digiVEC* series are a range of modular inverters for main and servo motors with sinusoidal or vector-orientated current control and resolver feedback. They are currently available in three enclosure sizes from 4 A to 80 A output current per phase.

The series will shortly be extended to 240 A and higher output currents are available on request.

Further details are provided separately.

Function:

digiVEC controls at high accuracy the position, speed or current for synchronous, asynchronous or DC motors. As standard, *digiVEC* operates as a torque, speed or position controller and as a follower drive in an electric shaft or as a follower drive for several mechanically-coupled motors. *digiVEC* also controls units such as stepping motors by means of pulse pattern programming.

digiVEC controls up to 15 parameter sets which can be activated via digital I/Os. Demands can be preset as either analog or digital values.

Mains supply:

All controllers are connected directly to the 400 V $\pm 15\%$, 45-65 Hz, 3-phase AC mains supply without transformers. The version for 460 V $+ 10\%/ -15\%$, 45-65 Hz, 3-phase AC has capacitors of the appropriate power on the DC bus.

Encoder:

As standard, the encoder for the controller is a resolver on the motor shaft. Software is also provided for operating with an encoder, with or without a zero marker or for controlling squirrel-cage motors without an encoder.

Connection facilities for the following motors:

Synchronous motors:

Permanently excited synchronous ACD motors (or DC brushless motors) possess perfect true-running characteristics even at the lowest speeds. Previously this was only possible with DC servos.

Squirrel-cage motors:

Favourably priced asynchronous CAD motors operate as servo drives with the *digiVEC*. They provide full rated torque as supplied. With the *digiVEC* a squirrel-cage motor becomes a high quality dynamic positioning drive.

DC motors:

digiVEC controls DC motors, supplies the field windings and uses a DC tacho as the encoder.

Field weakening operation:

All asynchronous and DC motors can achieve speeds above their rated speed using *digiVEC* field weakening characteristics. In general, the thermal rating of the motor limits the highest speed possible and not the maximum of 800 Hz for the final stages in *digiVEC*.

Connections:

Each *digiVEC* inverter has 12 digital inputs and 9 digital outputs as well as 4 analog inputs and 6 analog outputs. They can be programmed for special applications within certain limits beyond the standard configuration.

8 LEDs:

Operating status and fault conditions are indicated by LEDs on the front panel of the unit. They show, for example, the automatic test on the resolver and resolver cables on start-up.

Controller characteristics:

digiVEC drives every motor particularly smoothly and with high dynamics.

Analog signals are digitised using 18 bit resolution. The operating system runs in real time in a multitasking environment.

An adaptive control algorithm compensates for the temperature dependence of important controller parameters. The motor current is always sinusoidal. For this reason, speed is very stable and torque can be controlled accurately and linearly.

Interfaces:

A MS-DOS PC with a 386 processor or better is to be connected to the standard RS232 interface for configuration, commissioning and diagnostics. During operation all parameters can be adjusted by *digiVEC* through this interface. PC software for the standard configuration is supplied with the unit.

Multiple drives can be interlinked through an RS485 interface.

Ancillary equipment

- Software for spindle positioning, indexing, winding at constant tension, electronic gearboxes, metering pistons with immediate reversing and many other applications
- Encoder simulation card for simulating a normal signal from a mechanical encoder, with the facility to set any full number of pulses up to max. 1,024 pulses per pair of poles in the resolver.
- Voltage resistance up to max. 460 V for the mains supply.
- Interface to CAN bus and Sercos (in the near future).
- Supplementary card with 24 digital inputs or outputs (configurable) for applications.

2.2. Front view

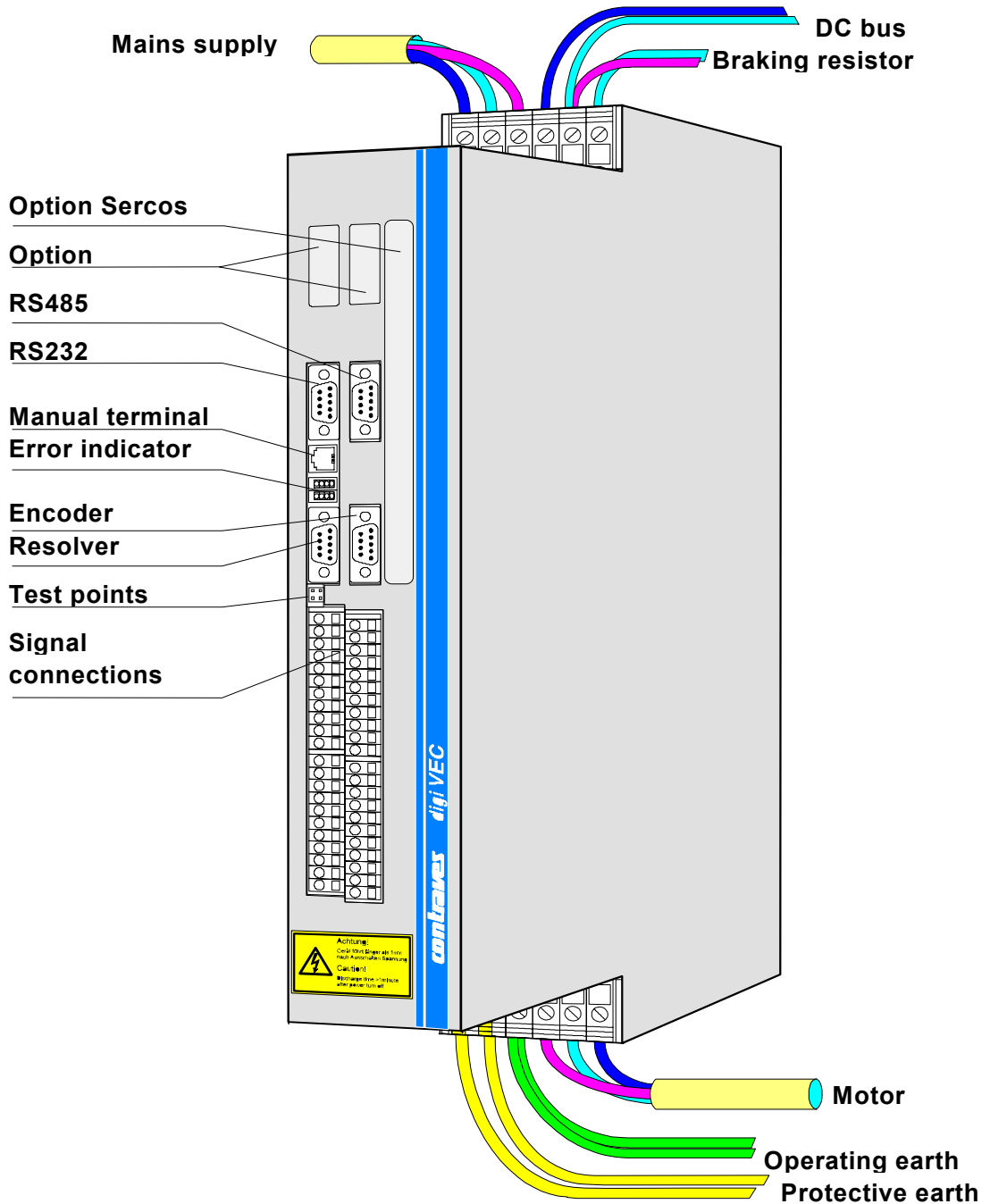

Fig. 2.2-1 Front view

2.3. Block circuit diagram

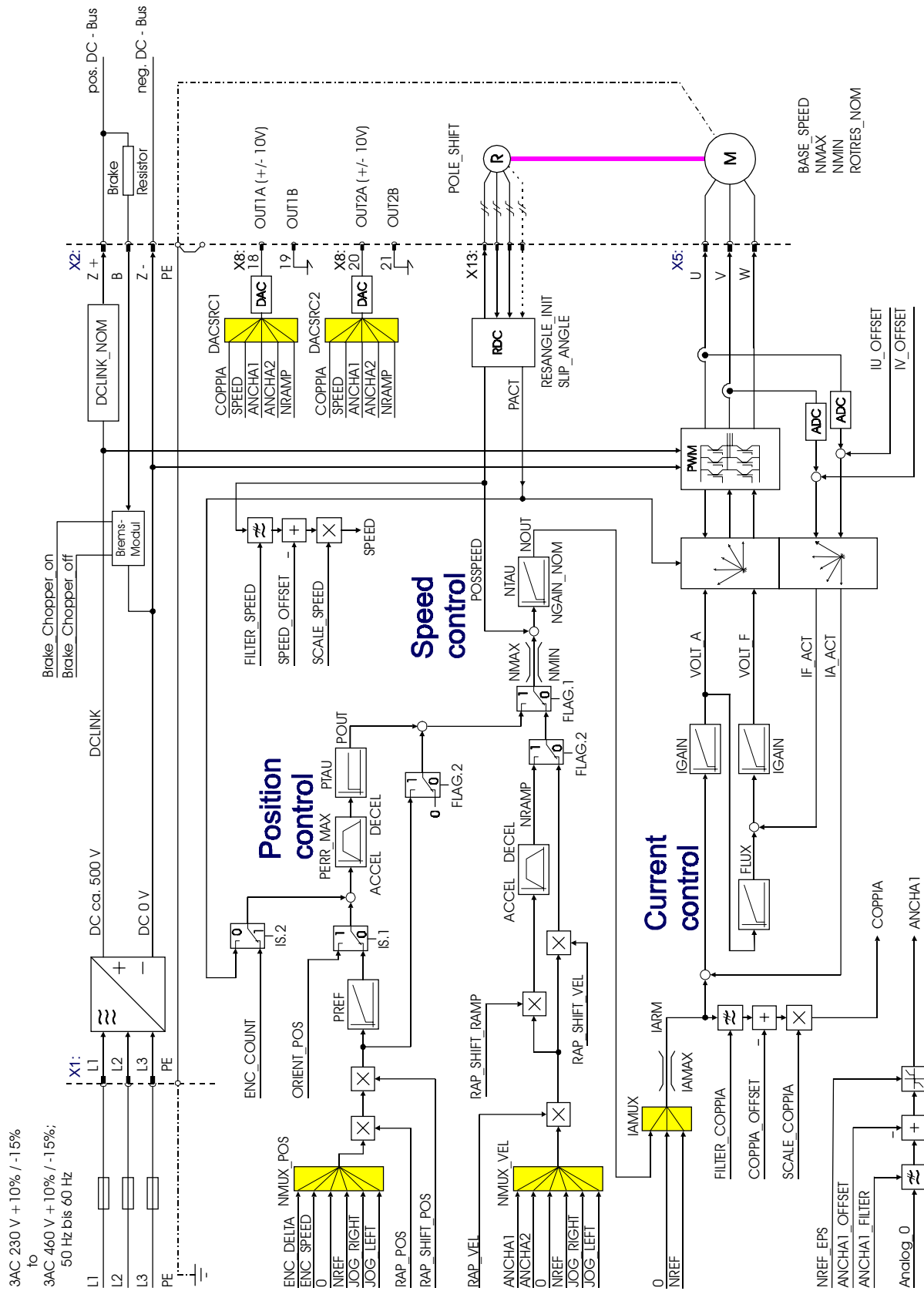

Fig. 2.3-1 Block circuit diagram

2.4. Unit description

The block circuit diagram shows part of the *digiVEC* schematic layout. It consists mainly of the following components described in the sections below:

- 3-phase bridge rectifier with subsequent voltage link
- Feedback facilities
- Parameters on the individual multiplexers
- Other parameters
- Control: Position, speed and current controllers
- Coordinates transformation, pulse width modulation (inverter)
- Memory areas

2.4.1. Three-phase bridge rectifier with subsequent voltage link

The mains (*L1, L2 and L3*) are supplied through an uncontrolled 3-phase bridge rectifier. The resulting DC voltage (approx. 560 V) is smoothed by the capacitor battery on the DC link.

The link circuit acts as an energy buffer to decouple the mains from the motor. The two connections for the DC bus are fed to terminals (*DC bus ZP and ZN*) to allow energy transfer as required when operating multiple inverter units.

The voltage on the link is monitored to relieve the power electronics. The minimum start-up value is defined with the parameter **DCLINK_NOM (approx. %)**. The shutdown value is 100 V lower (hysteresis).

The *brake module* (chopper) is also on the link. This brake chopper switches on the braking resistor at a link voltage of 675 V (depending on the mains input voltage). The braking resistor converts the energy fed back from the motor during braking into heat. If the link voltage falls below a certain lower limit the braking resistor is switched off again.

Brake_Chopper_off(V): and **Brake_Chopper_on(V)**: allow this process to be set up as required (the setting depending on the mains input voltage).

2.4.2. Feedback facilities

The drive controller can be operated with the following feedback systems:

Resolver (standard design):

Rotor position, speed actual value and direction of rotation are determined by a resolver on the motor. Resolver signals are fed through plug X2L to the RDC resolver signal processing unit where mainly the signals **POSSPEED (rpm)**=(speed actual value) and **PACT_LOW**= as well as **PACT_HIGH**= (position actual values) are used for position and speed control as well as coordinates transformation.

Encoder:

An encoder can be connected to *digiVEC* through plug X2H. The signals read in are designated as **ENC_COUNT** in the block circuit diagram. The signals **ENC_SPEED** and **ENC_DELTA** are formed from the encoder signal. The signal **ENC_DELTA** corresponds to the incremental increase in the encoder. **ENC_DELTA** can be applied to the position controller as the demand and **ENC_COUNT** as the actual value.

2.4.3. Parameters on the individual multiplexers

NMUX_POS Multiplexer position controllers:

- ENC_DELTA Demand for position controller through the encoder signal (Delta signal: See description of encoder above)
- ENC_SPEED Demand for position controller through the encoder signal
- 0 Demand = 0
- NREF, JOG_RIGHT, JOG_LEFT Internal demand preset

NMUX_VEL Input multiplexer speed controller:

- ANCHA1 Demand preset through an analog value via terminal X1:27 and X1:28
- ANCHA2 Demand preset through an analog value via terminal X1:25 and X1:26
- 0 Demand for speed controller = 0
- NREF, JOG_RIGHT, JOG_LEFT Internal demand preset

The differential analog inputs **ANCHAx(V):=** are read in every 240 μ s and are preprocessed. With the filter constant **ANCHAx_FILTER** any possible errors are eliminated and an offset **ANCHAx_OFFSET(V)**: is then subtracted. The corrected value is processed further with the dead zone function **NREF_EPS** (dead zone in mV). This means the value **ANCHAx(V)** = is equal to zero as long as the value at the input does not exceed the value of **NREF_EPS** (dead zone in mV).

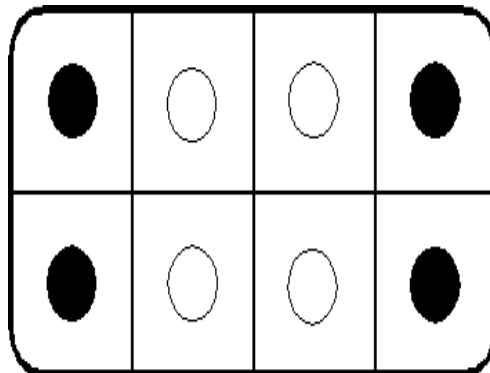

Fig. 2.4-1 Application

Application: This can be used if the motor should not drift when at a standstill.

The byte demand **ANCHAx_FILTER**: determines the time constant for filtering of the analog signals **ANCHAx (V)**. The following approximate relationship applies:

ANCHA1_FILTER: / ANCHA2_FILTER:	Time constant / limit frequency	Theoretical signal resolution ¹⁾
0	No filter	10 Bit
1	0.6 ms / 444 Hz	11 Bit
2	1.1 ms / 222 Hz	12 Bit
3	2.2 ms / 111 Hz	13 Bit
4	4.3 ms / 56 Hz	14 Bit
5	8.6 ms / 28 Hz	15 Bit
6	17 ms / 9.3 Hz	16 Bit
7	34 ms / 4.6 Hz	16 Bit
8	69 ms / 2.3 Hz	16 Bit

Note:

- A high value for **ANCHAx_FILTER**: improves resistance to interference and signal resolution but reduces control dynamics.
- A change in the parameter **ANCHAx_FILTER**: only takes effect after a new controller enable.

NREF(V) is an internal reference signal (demand). It can be adjusted either through an application program, the serial interface or by hand by the user.

The application facilities of **NREF(V)** are very versatile. Thus, for example, an application program can set the parameter as the demand for the position controller, i.e. a step-by-step feed can be produced automatically, or the higher level control gives a value for **NREF(V)** through the serial interface. If **NREF(V)** is overwritten by hand, it can serve for testing and commissioning purposes.

¹⁾ The solution of analog signals is only higher than 10 Bit, when the connection X1:23 of GND !

IAMUX **Input multiplexer current controller:**

- NOUT Speed controller output switched to the current controller input
- 0 Demand for current = 0
- NREF Digital demand preset

DACSRC1 and **DACSRC2**

Output signal selection for analog outputs X1:35 and X1:36

Signal selection and scaling using the configuration software (see configuration program manual).

- COPPIA Torque actual value
- SPEED Speed actual value
- ANCHA1 Analog demand preset output
- ANCHA2 Analog demand preset output

Scaling parameters: **SCALE_SPEED;**, **SCALE_COPPIA;**, **COPPIA_OFFSET;**, **SPEED_OFFSET;**

2.4.4. Other parameters

ACCEL (rpm/s): / DECEL (rpm/s):

An internally generated ramp can be used to adapt the dynamics to the mechanical limits of the machine.

A ramp can be applied or removed using flag settings (see section 5.7, Function of individual flags). Acceleration **ACCEL (rpm/s):** and braking **DECEL (rpm/s):** are freely definable.

NMAX (rpm): / NMIN (rpm):

These two values limit the maximum speed of the motor (limit switch function).

NMAX (rpm): limits the positive maximum speed and **NMIN (rpm):** limits the negative maximum speed. The values can be activated and de-activated through the digital inputs.

If the motor speed exceeds the value of **NMAX (rpm):** or **NMIN (rpm):** by approx. 300 rpm, the inverter is no longer able to control the speed (due to a fault or overload) and the monitor disables the controller.

2.4.5. Control: Position, Speed, Current controller

The control uses a cascade structure with position, speed and current control (torque and flux). The input signals for the control can be determined by the user as required using the internal multiplexers **NMUX_POS**, **NMUX_VEL** and **IAMUX**. They are processed in different cycles so that control algorithms do not affect each other.

Position control	:	Every 960 μs	corresponding to: 1.04 kHz
Speed control	:	Every 480 μs	corresponding to: 2.08 kHz
Current control	:	Every 240 μs	corresponding to: 4.16 kHz

Speed control

Depending on the setting of the multiplexer **NMUX_VEL** the demand for the speed controller can be an analog value **ANCHAx(V)**, a digital preset **NREF(V)**; or increments of an encoder through input **X2H (ENC_SPEED)** which can be scaled by **RAP_VEL (rpm/V)**; and **RAP_SHIFT_VEL**.

Conversion of internal units into rpm:

$$n[rpm] = \frac{NREF \times RAP_VEL \times 0,5 \times 2^{RAP_SHIFT_VEL} \times 1,70807}{RPZ}$$

(RPZ = resolver number of pairs of poles)

Actual value feedback is the speed of the motor **POSSPEED (rpm)**= calculated from the resolver signals.

Current control for torque and flux:

The motor current is divided into two current components at 90 degrees to each other which are affected separately. Thus with an asynchronous motor, just like with a DC motor, exciter flux and torque can be controlled independently (field-orientated control).

The currents of phases U and V taken up by the motor are measured, converted into digital signals (ADC) and then formed into the components for flux **IF_ACT** and torque **IA_ACT** at an angle of 90 degrees to each other by means of coordinates transformation and are used as actual value feedback for the current controller.

The higher level speed control circuit is to be deactivated for current or torque control. According to the block circuit diagram in section 2.3 the current multiplexer **IAMUX** is to be set to **NREF** for this purpose. The absolute demand is preset through **NREF**.

Position control

The position controller is switched in or out with *Flag.1* or **FLAG_POS**: = 02HEX. If position control is on, *Flag.2* can be used to activate feed forward (see section 5.7, Funktion of individual flags).

According to the block circuit diagram in section 2.3 this provides preliminary speed control, i.e. the demand for the position control is applied directly to the speed control circuit, whereby the control becomes more dynamic (faster).

Position control is activated using parameter **CMDREF**: = 04 HEX before firing is enabled.

The actual value is read in automatically as the demand when the controller is enabled, to prevent uncontrolled motor starting.

Depending on the setting of multiplexer **NMUX_POS (Adr)**: the demand preset for the position controller can be through an encoder signal **ENC_SPEED**, an absolute position **PREF_HIGH**, **PREF_LOW** etc., which can be scaled by **RAP_POS** : and **RAP_SHIFT_POS** :

Factor:
$$\frac{RAP_POS \times 2^{RAP_SHIFT_POST}}{32767 \times RPZ}$$

(RPZ = Resolver number of pairs of poles)

You can choose between the signals **PACT_LOW** and **PACT_HIGH** (position processing by the resolver) or **ENC_COUNT**, **ENC_HIGH** and **ENC_LOW** as the actual value feedback. Thus, for example, the position can be set to the position of a roll driven by a gearbox.

Speed acceleration and deceleration can be defined by the parameters **ACCEL (rpm/s)**: and **DECEL (rpm/s)**:. In addition it is possible to preset a maximum search speed for reaching the position using **PERR_MAX (rpm)**:.

Position controller gain is set with **PTAU**. The value of **PTAU** adjusts the proportional component of the controller (the default value for **PTAU** is 8).

If an encoder signal is to be used for demand preset it is important to ensure that jumper JP404 for the encoder supply is set on the DAM card (internal supply at 5 V DC). The input of position multiplexer **NMUX_POS** must be set to **ENC_SPEED**. The encoder input is activated with FLAG 4. The number of line markings on the encoder according to the rating plate is to be entered in parameter **ENC_LPR**:.

A special facility in position control is spindle positioning. If the system switches at input X1:20 from speed control to position control (only when firing is switched on), the value of **ORIENT_POS** is preset as the position. For this purpose, multiplexer **NMUX_POS (Adr)**: must be set to R0.

The ramp function **DECEL (rpm/s)**: now applies the actual speed (from the speed control) to the position **ORIENT_POS**. This prevents the spindles being set to the required angle position with the opposite direction of rotation.

Teach-in process

By setting input X1:19 (or **CMDREF**: = 08 HEX if command multiplexer **CMDMUX**: is set to input via the configuration program) the momentary position of the spindles is read in parameter **ORIENT_POS** with the drive at a standstill and is therefore available as the demand for positioning.

With the application software it is possible to read in up to 4 spindle positions.

2.4.6. Coordinates transformation, pulse width modulation

The signals **VOLTA** and **VOLTF** resulting from the current controller are applied to the coordinates transformation facility. This produces three voltages offset through 120° electrical which are converted into 3-phase AC voltages in the pulse width modulation unit.

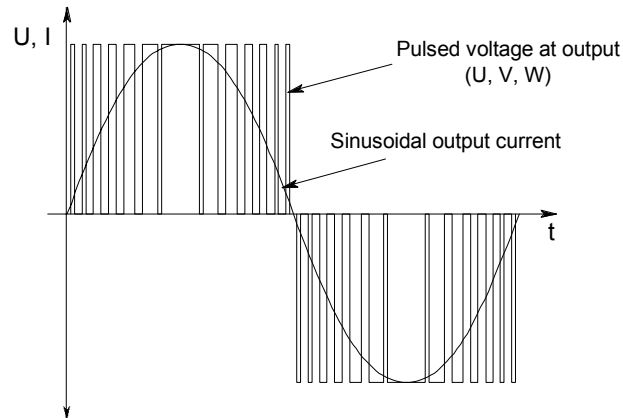

Fig. 2.4-2 Pulse width modulation

The 3-phase pulse inverter is equipped with IGBT modules (insulated gate bipolar transistor) so that low switching losses are achieved despite the high pulse frequency of 8 kHz.

2.4.7. Memory areas

Parameters and the operating system software are stored in three memory areas.

digiVEC operates with the latest data (*parameters*) in the work RAM.

When the controller supply voltage is switched on or after a system reset, depending on the status of the **FAST_FLAG.3** the data in the work RAM is compared with the Init_RAM (**FAST_FLAG: 00H**) or with the Flash memory (**FAST_FLAG: 04H**). If the content is different, the work RAM is updated from the relevant memory.

2.4.8. Encoder simulation (optional)

An encoder simulation option card is available from Contraves Antriebstechnik GmbH.

The encoder simulation card outputs pulses proportional to speed. The maximum number of pulses which can be output per revolution is 1024.

If a 3-pole or 2-pole resolver is used for speed feedback, many more pulses can be used per motor revolution..

Resolver	Max. number of pulses per motor revolution
Single pair of poles	1024
Two pairs of poles	2048
Three pairs of poles	3072

The number of pulses can be set with the parameter **ENC_LINES** using the parameter adjustment program.

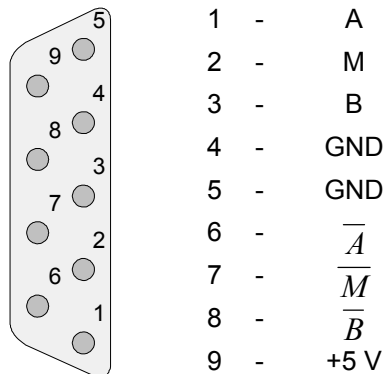
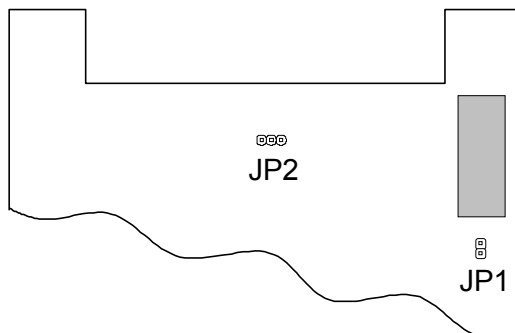

Fig. 2.4-3
Wiring of encoder output plug X4H



JP1: 5V electronics supply for encoder simulation.

If the electronics are to be supplied externally, JP1 is to be removed. Encoder simulation is then supplied through pin 9 of the sub-D plug.

JP2: Setting the high frequency

Fig. 2.4-4 Jumper setting

2.5. Intended use

The drive systems are designed and built according to the state of the art and accepted safety regulations. However, operation may cause risk to life and limb of operators or third parties and the drive may affect machines, plant or other items.

The drive system may only be operated when in perfect condition in accordance with the commissioning and operating instructions, and operators must be aware of the safety aspects and risks involved. Safe and reliable operation of the control requires correct transport, storage and installation as well as careful operation and maintenance.

In particular, any faults which could affect safety must be corrected immediately.

The drive systems are intended exclusively for controlling machines and plant.

Any other use is inappropriate and the manufacturer accepts no liability for any resultant damage or loss. The instructions on the mechanical and electrical design, commissioning and operation given in this manual must be observed for correct operation of the drive systems.

3. Technical data

- Direct mains connection $U_N = 400 \text{ V} \pm 15 \%$ (415 V +10 %, -15 %) 50/60 Hz, 3-phase
- Output 0 ... 350 V, 3-phase, max. $0.87 \times U_N$, 0 ... 750 Hz, resistant to short circuits and earth faults
- Link DC 450 V ... 750 V
- Pulse width modulation switching frequency 8 kHz
- Ambient temperature 0 ... 40°C
- Protection Class IP20 to DIN 40050, IEC144
- Humidity Class F to DIN 40040
- Easy matching to synchronous motors or asynchronous motors with field weakening
- For asynchronous motors, field weakening up to 1:6 at constant power
- Speed and position controller with resolver or encoder
- Analog demand preset with 15 bit resolution (14 bit + sign) or through serial interfaces
- 12 digital inputs and 9 digital outputs, 4 analog inputs and 6 analog outputs
- Networkable through RS485 interface
- Automatic matching to motor parameters (also online)
- Microprocessor controlled, real time multiprocessor operation system
- User configuration for input/output signals and control parameters, high flexibility in matching the control structure to the relevant application

Ancillary equipment

- Interface to CAN bus and Sercos (in the near future)
- Ancillary card with 24 configurable digital inputs or outputs
- Encoder simulation card
- Sine / cosine encoder processing

3.1. Ambient conditions

- The room should be dust-free if possible (for build-in units and cubicle-mounted units with air inlet at base without air filter).
- The ambient temperature must be between 0 ... 40°C.
- The relative air humidity may not exceed 90% (no condensation).
- The air supply may not contain corrosive gas.
- *digiVEC* produces power losses and heats the environment. Adequate spacing from heat-sensitive equipment is essential.
- The air flow may not be restricted. Minimum clearances of 100 mm must be provided at air inlets and outlets.
- *digiVEC* must be protected against magnetic and electrical interference.
- Special filter modules are provided for *digiVEC* to comply with EMC guidelines. They are available from Contraves Antriebstechnik in Mainz and comply with the appropriate regulations.

3.2. Performance overview

digivec type (frame sizespecific unit data)	DAC	4	7	11	18	28	45	60	80
Mains fuse (FF) ¹⁾ (all units individually)	I (A)	10	16	25	40	63	80	100	125
Mains fuse (T) ¹⁾ (several units together: details must be multiplied by the number of units)	I (A)	6	10	16	25	40	63	80	100
Rated power²⁾	P_N (kW)	2.5	4.2	6.8	11.2	17.5	27	36	48
Peak power ²⁾ (t = 60 s) (=P _N *√2)	P _{60s} (kW)	3.5	6	10	15.8	24.7	38	51	68
Peak power ²⁾ (t = 1 s) (=P _N *2; from DAC 45: =P _N *1,6)	P _{1s} (kW)	5	8.4	16.6	22.4	35	43	58	77
Rated current	I_N (A)	4	7	11	18	28	45	60	80
Peak current (t = 60 s) (=I _N *√2)	I _{60s} (A)	6	10	15	25	40	63	84	112
Peak current (t = 1 s) (=I _N *2; from DAC 45: =I _N *1,6)	I _{1s} (A)	8	14	22	36	56	72	96	128
Internal braking resistor	R (Ω)	30	30	30	15	15	External braking resistor only (10 Ω recommended)		
Continuous braking capacity	P (kW)	0.6	0.6	0.6	1.2	1.2	Depending on external braking resistor		
Braking capacity (t = 3 s)	P (kW)	14	14	14	28	28	Depending on external braking resistor		
External power supply 24 V DC (20.4 ... 28.8 V) or 18 V - 24 V AC	P (W)	40	40	40	50	50	75	75	75
Weight	m (kg)	5	6	6	11	11	-	-	-

1) The valid regulations for the place of installation and operation have to be considered in each case

2) Value means ...

- Apparent Power **S** in kVA for asynchronous motors
- Real Power **P** in kW for synchronous motors resp. for brushless servo motors

3.3. Input test

digiVEC is to be checked for any damage in transit after unpacking and before commissioning. All plug and screw connections are to be checked to ensure they are tight.

Check that the connections required for application have been made and are correct (digital and analog inputs and outputs etc.) before switching on the primary voltage.

3.4. CE Declaration of Conformity

CE Declaration of Conformity 96 to guideline 89 / 336 EC

(Harmonisation of legislation on electromagnetic compatibility in Member States)

Servo inverters of the DAC 4 - DAC 28 series are not considered independently operated units in the sense of the law on electromagnetic compatibility.

They are only assessed for EMC when inverters are integrated into a drive system.

Contraves Antriebstechnik GmbH, An der Fahrt 13, D-55124 Mainz-Gonsenheim

declares that the above units comply with the EMC requirements for radiated interference and interference resistance according to 89/336EC.

The conformity procedure is ensured according to the test standards EN 50081-1 and EN 50082-2.

Basic standards taken into account when testing radiated interference:	EN 55022/94, EN 55011/91
--	--------------------------

Basic standards taken into account when testing interference resistance:	EN 61000-4-2/95
--	-----------------

ENV 50140/93

ENV 50204/93

EN 61000-4-4/95

EN 61000-4-5/93

ENV 50141/93

Compliance with the EMC Directives of the EC was confirmed by an accredited test centre.

Mainz-Gonsenheim, date 9 January 1996



Signed: Dr. B. Kind

4. Installation

4.1. *digiVEC* monitor program

The monitor program described below is to be used for communication between *digiVEC* and a PC. Two versions are available: 1. In German. 2. In English.
System requirements: IBM-compatible PC (XT/AT) with MS-DOS operating system.
All files required for the configuration program are provided on the diskette supplied.

The program consists of the following files:

- START.BAT ⇒ Normal start-up program with English user interface
- STARTGER.BAT ⇒ German user interface
- MOT.CFG ⇒ Last configuration is saved - screen color etc.
- MOTGER.EXE ⇒ Program in German
- MOTUS.EXE ⇒ Program in English
- PARALIS.EXE ⇒ Parameter files can be printed using a specific command
- MOTGER.HLP ⇒ Help file in German
- MOTUS.HLP ⇒ Help file in English
- *.LBY
 parameters) ⇒ Library containing all parameters (required if you want to set new
- *.PFL ⇒ Profiles
- MUXLIB.LBY ⇒ Multiplexer library
- HINWEIS.TXT ⇒ Program installation notes

4.1.1. Program installation

The above files should be copied into a directory C:\CONTRAVS\ on your hard drive.
No special driver is needed.

4.1.2. Running the monitor program

The program is run at the DOS prompt using START.BAT or STARTGER.BAT. If you have not entered the path in your AUTOEXEC.BAT file you must first change to the relevant directory.

Offline menus:

File

- Quit Exit from the program
- About mot Information
- Library Edit library

Configuration

- **Colors** Change colors of different menus
- **Screen** Pull-down menus can be edited, for example
 - *Shiftrange* Max. number of lines online screen can be shifted
- **Ports** Select interface for communication between drive and PC
- **Options** Start with online immediately (according to Help program)
- **Security level** Configure security level
- **Block size** Change parameter block size
- **Telegram delay** Set telegram wait time

- **Files**
 - *Library path* Path statement for saving files created online
e.g. C:\CONTRAVS\DATEN\
 - *Profile path* ditto
 - *Program path* ditto
 - *Parameter path* ditto
 - *Filename extensions* LBY, PFL, HEX, PAR (It is possible to change filename extensions but it is better not to do so, to remain compatible with Contraves in an emergency)
 - *Standard Library* Select default library file, always loaded on program start
 - *Standard Profile* User interface, parameter configuration to be loaded on program start
 - *Multiplexer Library* Library always loaded when a multiplexer program is called
 - *Help* Select whether English or German Help is used

The profile should always be loaded and the configuration set after running the program for the first time.

- **Save** Save settings
- **Save as** Save under a different filename

Online

- **Start online** Start online operation

The following menus are to be noted in online operation:

File

- **Open profile** Open the profile containing the user interface, i.e. the number of parameters and their locations.
- **Reload profile** Reload the original user interface
- **Save profile** Save profile under same name after editing

Attention! Do not overwrite the original profiles, so that you can contact Contraves in an emergency (see Save Profile As)

- **Save profile As** Save the profile under a different name
- **ESC: Close menu** Close pull-down menu
- **Quit online** Exit from online operation (another user interface is opened)

Mode

- **Command value edit** Standard setting for checking and adjusting parameter values
- **Display only** Display only, no parameter adjustment possible
- **Clear** Clear parameters.
(First click on Clear ⇒ Parameters ⇒ parameters are cleared) or (click on Parameter ⇒ Del ⇒ parameter is cleared)

Attention! The parameters are cleared until another menu option is selected!!!

- **Move** Move parameters (click on the Parameter, hold down the left mouse key and then move)
If you click on the parameter at the end of the field, the field can be enlarged or reduced to the right or left
- **Parameter specific.** Edit parameter names, formats etc. Can also be called with **F8**.

Attention! The original name should be noted in brackets to maintain compatibility for service purposes!

Attention! Only the description may be edited! Do not change the pin no. as otherwise the addresses will no longer match the parameters!

- Insert new parameter** Click on this to move to a new field (where you want to place the parameter) and hold down the left mouse button. The complete parameter list opens and you can select the parameter and confirm with ENTER. Or move the cursor to a free space and use the Insert command. ⇒ **INSERT**
- Insert comment** Insert comment on a free space; the left mouse button opens a field containing strokes.
Then **Mode** ⇒ **Parameter specification** or **F8** ⇒ **Parameter specification**, move to the field with the mouse and activate with the left mouse button, enter a comment in the description, confirm with **ENTER** and confirm with **ESC**.
- Edit library** Edit the library. Not used by the user unless you wish to open a new library (when activated, a window opens and you can page with **F9** or **F10** and select the parameter). **Edit** ⇒ **Open** - Open new library

Transfer

Data is read, saved or transferred

- **Flash** ⇒ **Hexfile** A hex file is produced from the flash content (the complete program is saved)
- **Ram** ⇒ **Hexfile** A hex file is produced from the RAM content (the complete program is saved)
- **Hexfile** ⇒ **Ram** The hex file is loaded into the RAM (e.g. load hex file supplied into RAM)
Hexfile ⇒ **Flash** The hex file is loaded into the flash memory
Initram Param. save The parameters in the init RAM are saved in a parameter file (needed to have the same parameter values available if you want to transfer data from one drive to another)
- **Work RAM Param. save** The parameters in the work RAM are saved in a parameter file (see init RAM parameter save)
- **Parameter** ⇒ **Initram** The parameter file (as created above) is loaded into the init RAM
- **Parameter** ⇒ **Work RAM** The parameter file (as created above) is loaded into the work RAM
- **Work RAM** ⇒ **Initram** Transfer parameter values from work RAM to init RAM (save edited values before switching off)
- **Initram** ⇒ **Work RAM** Transfer parameter values from init RAM to work RAM
- **Initram** ⇒ **Flash** Transfer parameter values from init RAM to flash RAM (changes are saved in flash memory)
- **Clear Initram** Clear RAM contents ⇒ Reset (the data is loaded after a restart)
- **Help** This is where you find the keyboard commands (e.g. address search with several stations:
If several drives are operated together, e.g. through the RS485 interface, each drive must be assigned its own station address. The default address is 80 hex.
In multiple drive systems the addresses 81 hex, 82 hex etc. are used.
Press F9 or F10 to communicate with these addresses in order to search for the previous or next drive.

4.1.3. Menu overview, digiVEC user interface

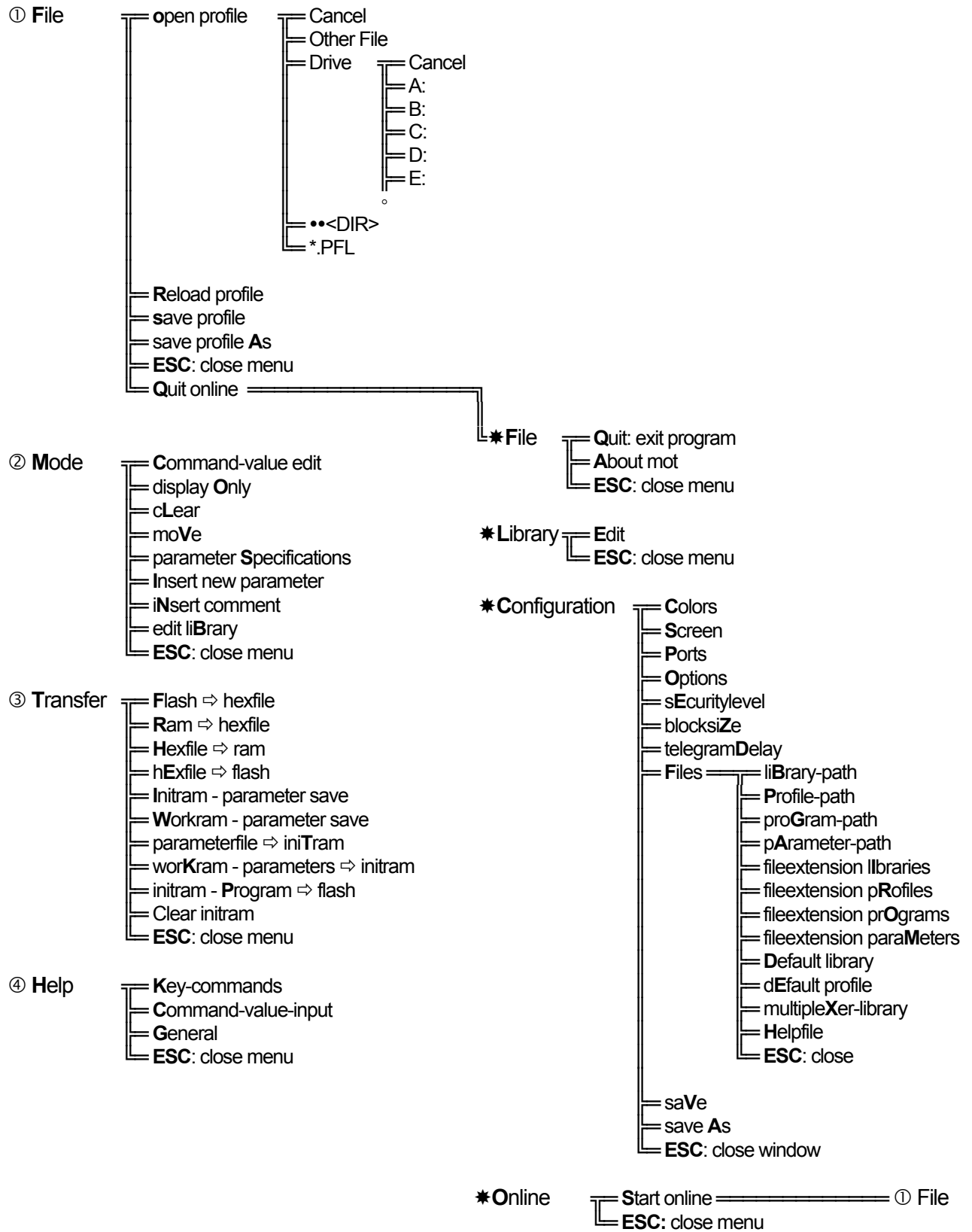

4.1.4. Using the configuration program

The drive is mainly configured using the so-called profile. The profile represents all the relevant parameters in the form of text and allows easy parameter-based editing. The profile or configuration program user interface can be adapted by the user to match the relevant application if necessary.

The illustration below shows the user interface for the standard profile:

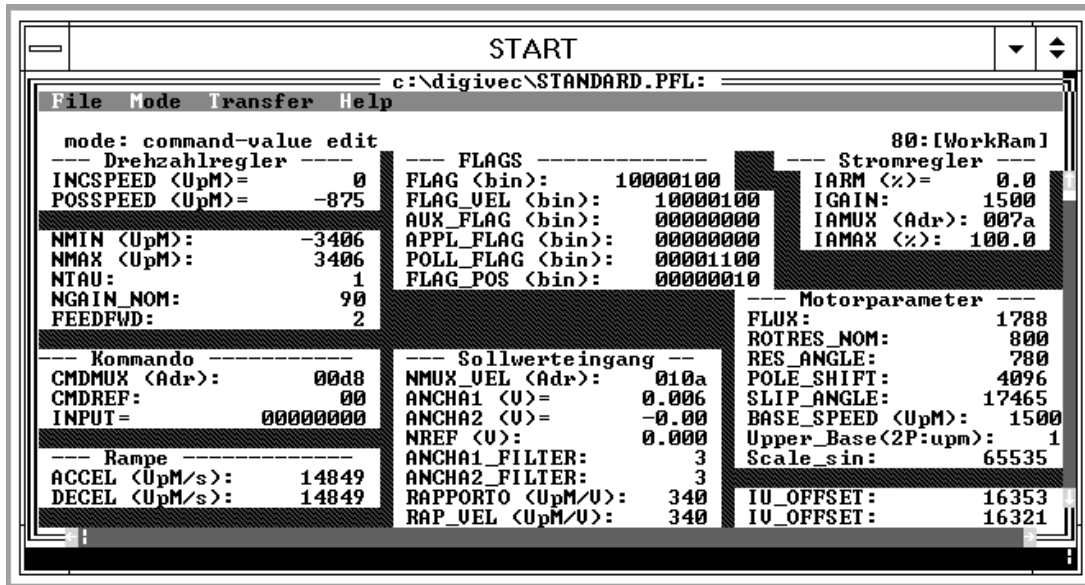

Fig. 4.1-1 User interface, standard profile

4.1.5. Using the Help system

The integral Help system explains software operation and the meaning of individual parameters.



Fig. 4.1-2 Example, Help system

The relevant Help page is activated according to the cursor position by pressing function key F1. Further help is available for highlighted parts of the text.

4.2. General wiring guidelines

The following points should help to prevent wiring problems and are intended as guidelines for EMC-compliant wiring.

- The cross-section of the protective conductor in the feed cable to the cubicle must be at least 10 mm² copper or a second protective conductor must be laid in parallel according to VDE 0160 section 6.5.2.1 due to the current induced by the inverter (> 3.5 mA) through the protective earth conductor PE, according to DIN VDE 0160.
- At higher ratings the minimum cross-section of the protective conductor must be suitably related to the cross-section of the outer conductor. See DIN 57100 Part 540 / VDE 0100 Part 540 Table 2.
- The currents induced by the inverter can be up to 100 mA. Operation with 30 mA FI protection switches is therefore not possible.
- Avoid using a shared terminal block for mains input and motor output.
- Control signal cables are to be screened and, if necessary, individually twisted pairs of conductors inside the screen are to be screened again.
- Control signals are to be transferred using twisted pairs of conductors (100 twists per metre).

Attention! The unit remains live for more than one minute after it is switched off. Before opening the unit or touching live parts it is essential to check that the DC link has discharged (terminal ZN/ZP) -> link voltage up to 600 V DC.

To avoid faults the cables used are to be laid in three separate groups. These groups should run separately or be placed in separate cable ducts. Cables should be as short as possible.

Group the cable as follows:

- Mains cables
- Motor cables
- Signal wiring (encoder, resolver, controller, signal feeds etc.)

If units which contain power electronics are installed in or close to switchgear systems or are operated on the same mains supply, interference suppression will be required for the switchgear systems.

- Coils in contactors, switchgear and relay combinations are to be connected with RC components or diodes
- Lines generating interference (power circuits, contactor control circuits etc.) are to be laid separately and spaced sufficiently from control cables
- The conductor for motor temperature protection may not be located in the resolver cable

4.3. Motor and power connections

4.3.1. Screening and interference suppression

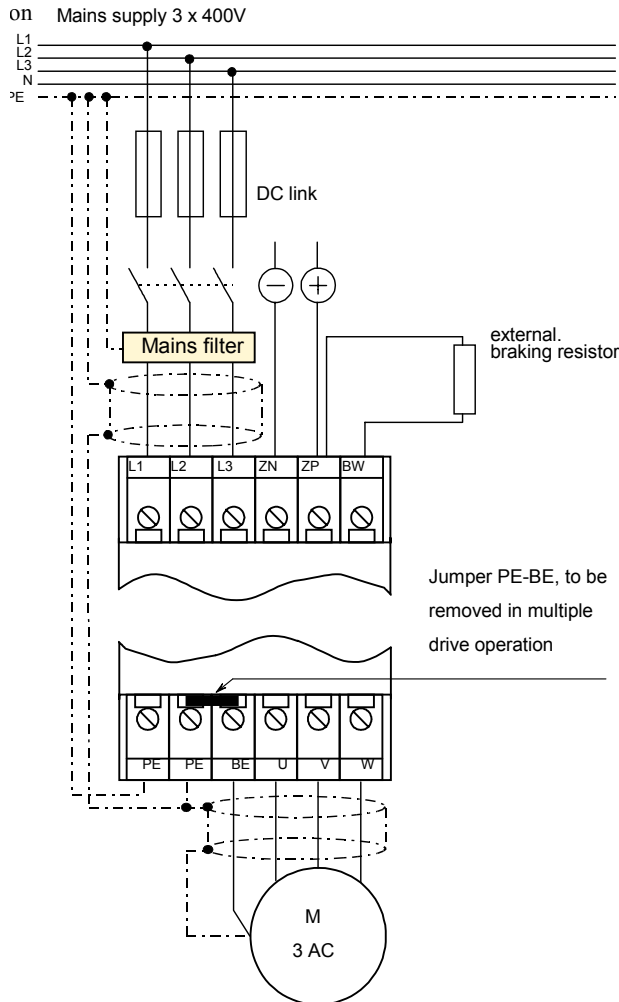

L1, L2, L3: Mains supply cables, 3 · 400 VAC, 50/60 Hz

DC link connections:
for multiple drive systems:
ZP = Plus pole
ZN = Minus pole

Braking resistor: Connected to plus pole (ZP) and switched outlet (BW)

Protective earth PE: Two terminals for motor and supply

Operating earth BE:
In multiple drives the BE terminals of all units are to be interconnected and earthed at one point

U, V, W: Motor connections

Attention! The screen on the motor supply and mains cable is to be firmly connected at both end!

Fig. 4.3-1 Screening and interference suppression

4.3.2. Cubicle installation

- When mounting plates are used, ensure a good electrically conducting contact.
- If mounting plates with a surface finish are used, the finish must be removed at the connection points for screens, inverters and mains filters to produce a good low impedance connection.
- If several mounting plates are used they are to be electrically connected using generously sized copper straps.

4.3.3. Motor connection

- Motor cables are to be screened and connected at both ends.
- Connect the screen to the inverter PE terminal.
- If a motor with a terminal box is used, the end of the screen is to be connected to the PE terminal on the motor. (If a Contraves motor with plug connectors is used, this connection is already provided through the plug).
- Screens are also to be firmly and generously connected to the mounting plate.
- We recommend a connection on the bare metal mounting point using earth clamps. (See Fig. 4.3-2 Contacting, cable screen)
- Unscreened cable ends are to be as short as possible.
- Motor cables are too be connected to the screw terminals U, V, W, BE on the inverter.
- In practice, the length of cable from the inverter to the motor can be unlimited. However, if it exceeds 100 m, contact the supplier for any guidelines to be observed.

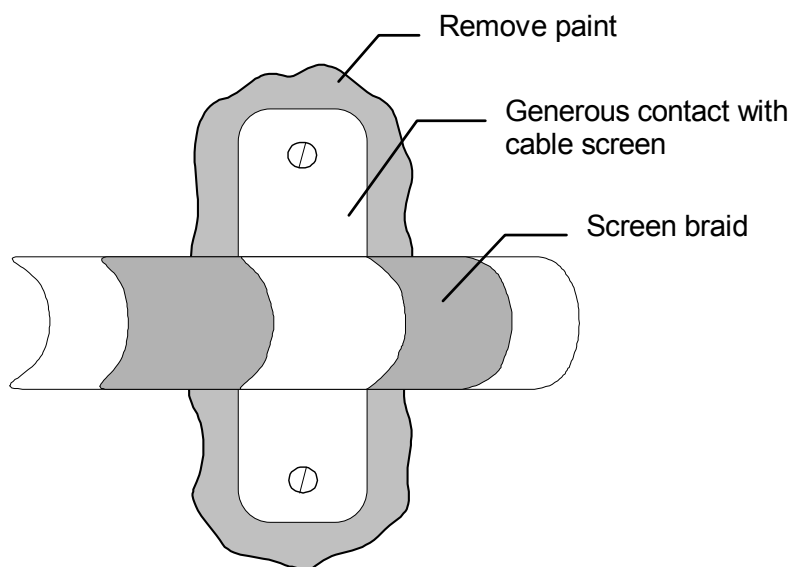

Fig. 4.3-2 Contacting, cable screen

4.3.4. Power connections

- Use the cable cross-section for the supply cables according to the type of controller used (see section 4.3.5 Supply cable cross-sections for mains and motor connection:).
- The controller mains filter is to be used.
- Connect the mains cables to terminals L1, L2 and L3 on the inverter.
- The PE cable is connected to terminal PE at the base of the inverter.
- Connect the screen correctly (see motor connections).

4.3.5. Supply cable cross-sections for mains and motor connection:

The minimum cross-section is specified as follows according to EN 60204, Part 1, or VDE 0113:

DAC Type	Recommended supply cable cross-section ¹⁾	Fuse ¹⁾
4	1.5 mm ²	10 A / FF
7	1.5 mm ²	16 A / FF
11	2.5 mm ²	25 A / FF
18	4 mm ²	40 A / FF
28	10 mm ²	63 A / FF
45	16 mm ²	80 A / FF
60	35 mm ²	100 A / FF
80	50 mm ²	125 A / FF
100	70 mm ²	160 A / FF

1) The valid regulations for the place of installation and operation have to be considered in each case

4.3.6. Mains filters, filters for controller electronics supply voltage

Controller type	Mains filter	Filter for control electronics
DAC 4	E 600 200 010	E 600 250 010
DAC 7	E 600 200 010	E 600 250 010
DAC 11	E 600 200 015	E 600 250 010
DAC 18	E 600 200 020	E 600 250 010
DAC 28	E 600 200 030	E 600 250 010
DAC 45	E 600 200 040	E 600 250 010
DAC 60	E 600 200 050	E 600 250 010

The filters stated comply with interference suppression class A (EN 50082-2/95).

If required, suitable filters are available from Contraves Antriebstechnik GmbH to provide interference suppression according to class B.

4.4. Signal leads

- Signal leads (analog and digital) must always be screened. The screen must be connected at both ends.
- The screen must be connected firmly and generously.
- We recommend a connection on the bare metal mounting point using earth clamps (see Fig. 4.3-2 Contacting, cable screen)
- Keep signal leads as short as possible.

4.5. External braking resistors

The brake chopper is activated to limit the maximum link voltage. This discharges the link through the external braking resistor when the permitted voltage is exceeded (**BRAKE_CHOPPER_ON**, **BRAKE_CHOPPER_OFF**).

If the internal continuous braking capacity is not sufficient, an external braking resistor can be connected to plus pole ZP and switched output BW. The minimum resistance values shown in the following table are to be used to calculate the continuous braking capacity. The braking resistor starting voltage varies according to the mains voltage. When using 400 V AC mains voltage the starting voltage is 675 V.

DAC Type	Peak power	Min. resistance	Max. braking current
4, 7, 11	14 kW	30 Ω	22 A
18	28 kW	15 Ω	43 A
28	42 kW	10 Ω	65 A

ATTENTION! The internal braking resistor may not be connected when an external braking resistor is used.

The values preset for **BRAKE_CHOPPER_ON** or **BRAKE_CHOPPER_OFF** respectively are 675 V and 670 V. If a 220 V AC input network is used, both values must be reduced according to the mains voltage.

4.6. External supply voltage

The control electronics and the interfaces must be operated using an external supply voltage. If no 24 V DC supply voltage is available or cannot be used for reasons of electrical separation, the *digiVEC* can also be supplied directly with an AC voltage from a transformer. This is used to internally generate the +5 V, +15 V and -15 V voltages with separate potential (chopper power supply). The supply voltage is protected by a fuse (2 A).

	DAC 4 ... 60
DC input voltage	24 V DC (20.4 ... 28.8 V)
AC input voltage	18 V AC ... 24 V AC
Terminal number	X1:43 (+); X1:44 (ground)

Note: We recommend using the appropriate filters to suppress interference on the 24 V controller supply voltage. These are available from Contraves Antriebstechnik.

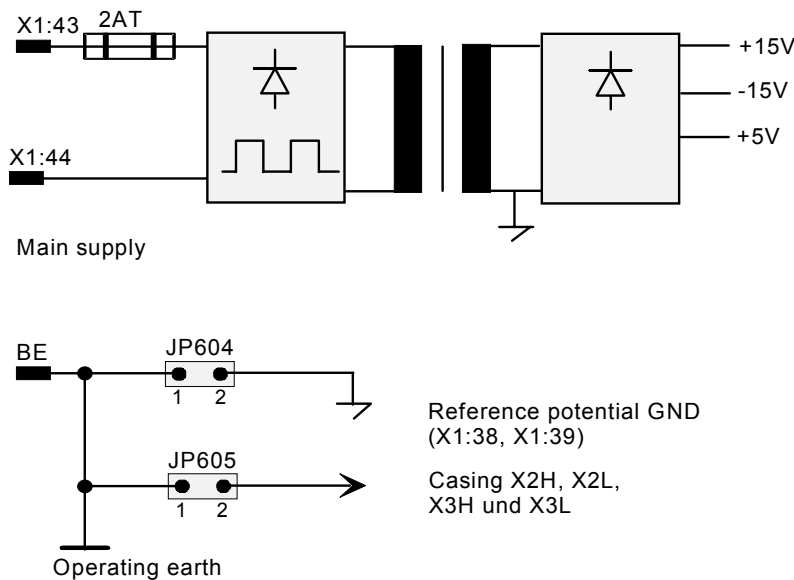

Fig. 4.6-1 Basic circuit diagram, external supply voltage

4.7. Fuses in electronic circuits

If the application demands a higher level of protection the unit can be fitted with super-fast fuses. These fuses offer protection for the rectifier bridges. Transistor bridges are protected electronically by the internal current monitor.

Each unit must be fused individually if super-fast fuses are used.

4.8. Feedback systems

4.8.1. Resolver connection

A resolver allows the rotor position, speed actual value and direction of rotation to be determined. Signal processing in the controller mainly produces the parameters *POSSPEED* and *PACT_LOW* or *PACT_HIGH* used for speed control and coordinates transformation. Resolver signals are applied to the resolver connection on the motor through plug X2L on the *digiVEC*.

Connection for resolver plug X2L:

Plug: 9-pin sub-D plug (male) on *digiVEC*, socket (female) on cable.

Contact wiring:

1	Resolver supply (12 kHz, 7 V _{eff})
2	Resolver cosine
3	Resolver cosine
4	Resolver sinusoidal
5	Resolver sinusoidal
6	GND
7-9	Internal screens
Plug casing	Outer screen

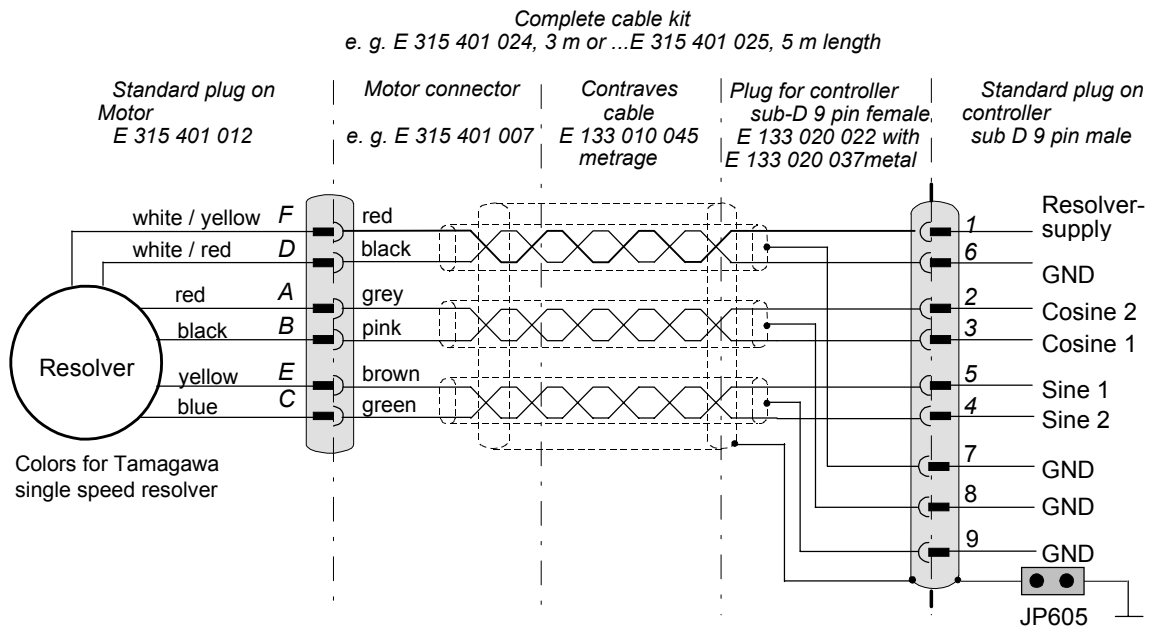

Fig. 4.8-1 Connection for resolver

Important! The outer screen in the resolver cable is to be connected to the plug casing. The inner and outer screens may not touch. Jumper JP605 must be in position (as supplied) to connect both plug casings to the operating earth (BE).

4.8.2. Encoder connection

Connection for encoder, plug X2H:

Plug: 9-pin sub-D, socket (female) on *digiVEC*, plug (male) on cable

Contact wiring:

1	A
2	M (zero pulse)
3	B
4, 5	GND
6	\overline{A}
7	\overline{M} (Nullpuls)
8	\overline{B}
9	+5 V (internal)
Plug casing	Screen

The encoder cable screen is to be connected to the plug casing. Jumper JP605 must be installed to connect the casing to the operating earth (BE).

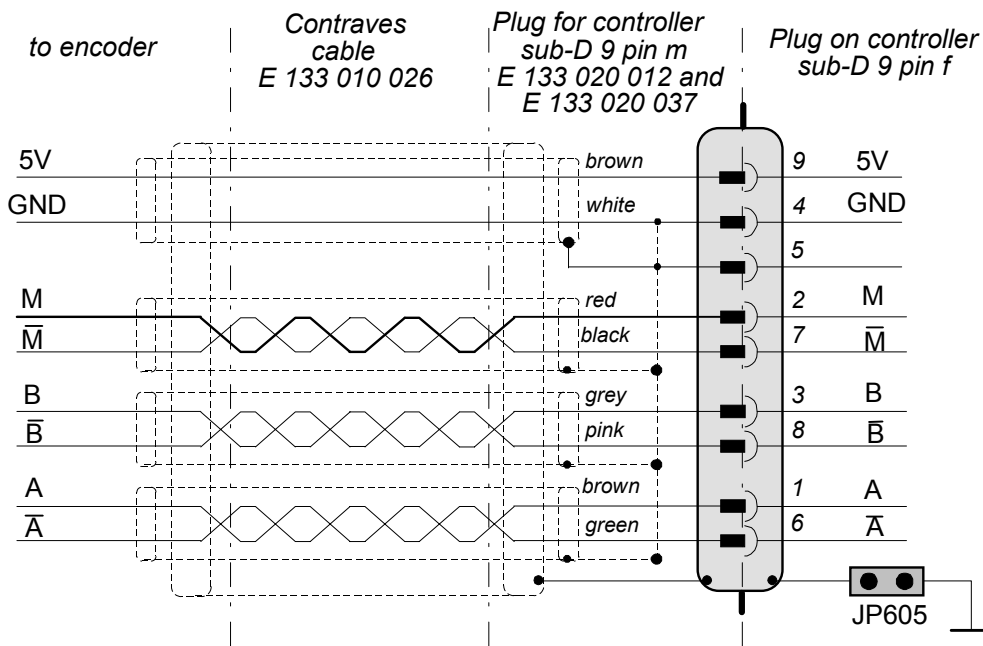

Fig. 4.8-2 Connection for encoder

4.8.2.1. Encoder supply

An external supply for the encoder can be connected through pin X1:1. An internal supply of 5 V is standard. Jumper JP 404 must be installed to supply the encoder with 5 V internal.

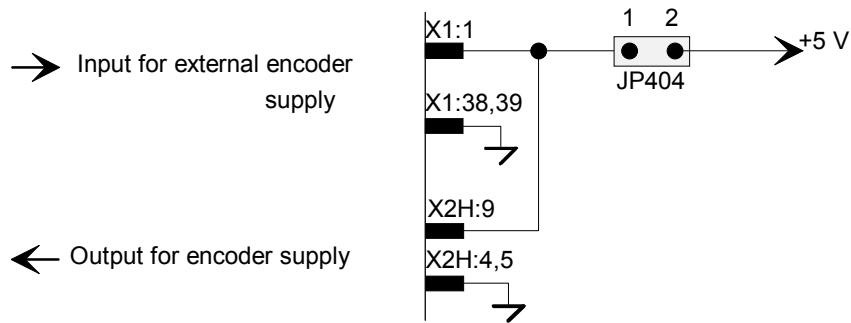

Fig. 4.8-3 Basic connection, encoder supply

4.8.3. Wiring of terminal strip X1:

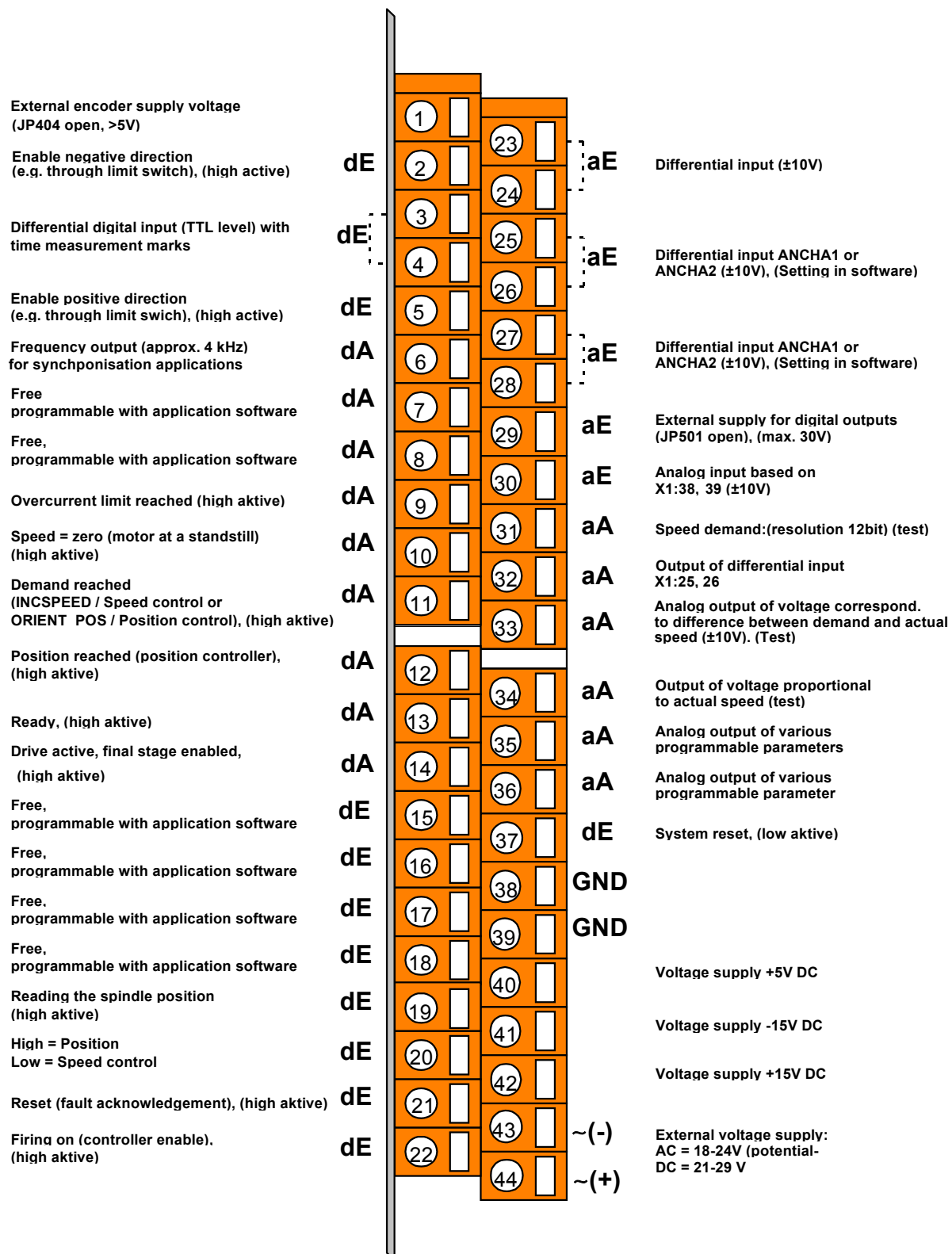

Fig. 4.8-4 Terminal strip X1

Legend:
 aA - analog output
 aE - analog input
 dA - digital output
 dE - digital input

4.8.4. Analog inputs and outputs

4.8.4.1. Differential analog inputs

Three differential analog inputs are available at X1:23 ... X1:28. They can be used for signals such as speed, position or current preset.

Technical data of analog inputs:

- Input resistance 66 kΩ
- Differential voltage -10 V ... +10 V
- Common mode -25 V ... +25 V

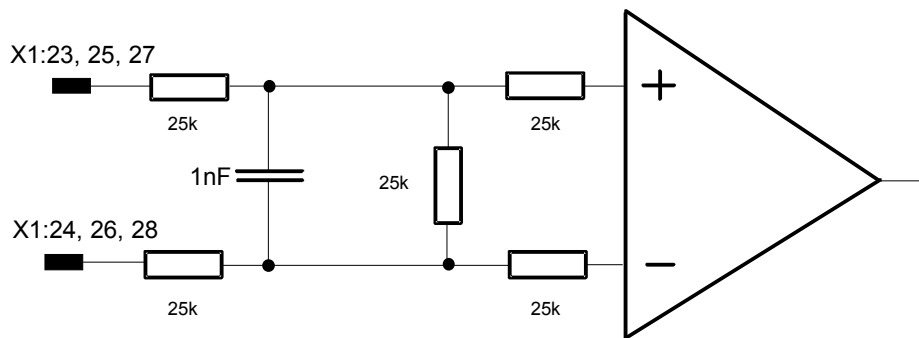

Fig. 4.8-4 Basic circuit diagram, differential analog inputs

4.8.4.2. Unipolar analog input

Unipolar analog input X1:30 is provided for supplying a DC tachometer signal, for example, which is to be limited to ± 10 V using external resistors.

Technical data:

- Max. voltage -12 V ... +12 V

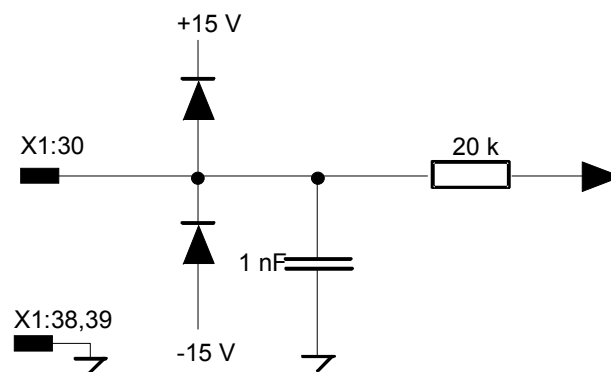

Fig. 4.8-5 Basic circuit diagram, unipolar analog input

4.8.4.3. Analog outputs

digiVEC has 6 analog outputs. These are not electrically separate (reference potential GND). The outputs are not decoupled! Incorrect loading (short circuit) can destroy the operational amplifier.

Technical data of analog outputs:

- Output voltage -10 V ... +10 V
- Output current -20 mA ... +20 mA
- Reference potential GND (X1:38, X1:39)

- X1:31** Output of digitally calculated speed demand, 12 bit resolution (4.9 mV/bit). This output is for test purposes.
- X1:32** Analog output of differential input X1:25, 26 (12 bit resolution).
- X1:33** Analog output of the difference between the voltage corresponding to demand and actual speed (± 10 V). This output is for test purposes.
- X1:34** Output of a voltage (± 10 V) proportional to actual speed. This output is for test purposes.
- X1:35** The output can be wired as required using the configuration program and parameter **DASRC2**, for example with the latest actual values COPPIA, IARM etc. The menus are accessed using function keys F5 or F6.
- X1:36** The output can be wired as required in the configuration program using parameter **DASRC1**, for example with the latest actual values COPPIA, IARM etc. The menus are accessed using function keys F5 or F6.

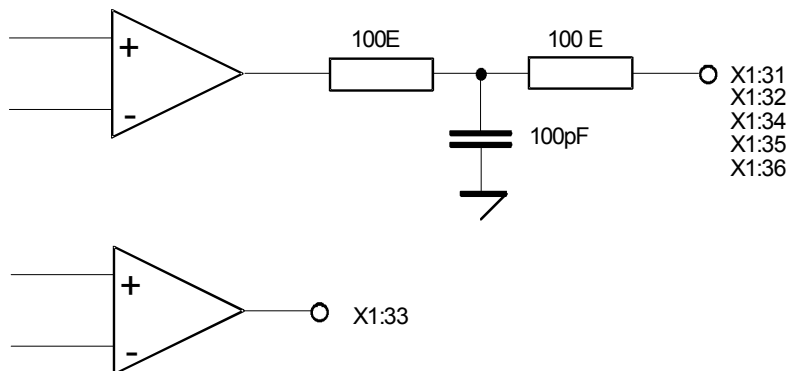

Fig. 4.8-6 Function of analog outputs

4.8.5. Digital inputs and outputs

4.8.5.1. Digital inputs

The digital inputs X1:2, X1:5 and X1:15 to X1:22 are not electrically separated. Their reference potential GND is X1:38 or X1:39.

Switching level

- Logic High +11 V ... +30 V
- Logic Low -3 V ... +4 V

The function description for the digital inputs refers to the active condition (Logic High) and standard software.

Attention! Only the function description supplied applies to special software!

X1:22	Firing On, Start, Controller Enable
X1:21	Reset (Acknowledge Fault)
X1:20	Switching from speed control (Logic Low) to position control (Logic High).
X1:19	Reading the spindle position, high active
X1:5	Activate or deactivate positive speed limit (set with software)
X1:2	Activate or deactivate negative speed limit (set with software)
X1:15 ... X1:18	Not used, can be programmed with the application software

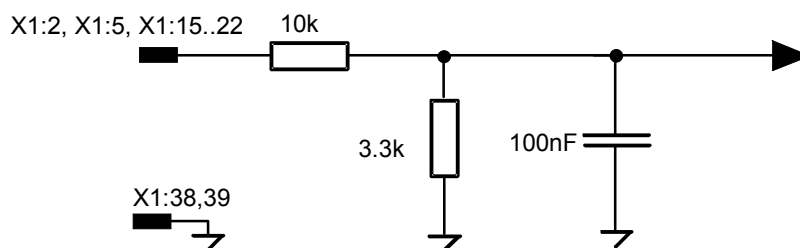

Fig. 4.8-7 Basic circuit diagram, digital inputs

Terminals X1:3 and X1:4 show a digital differential input with time measurement markers at TTL level. The time resolution is 1 μ s. The input can be used by application programs.

Switching level

- Logic High +3 V ... +5 V
- Logic Low -3 V ... -5 V

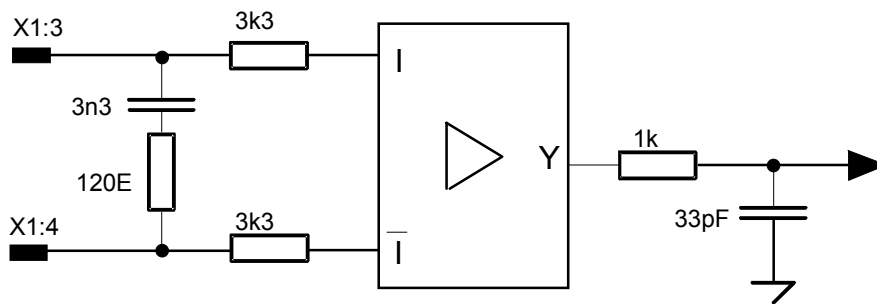

Fig. 4.8-8 Basic circuit diagram with time measurement markers at TTL level

Digital input X1:37 is fed directly through the input circuit to the **Reset** for the microprocessor and the logic. The reset is active when low.

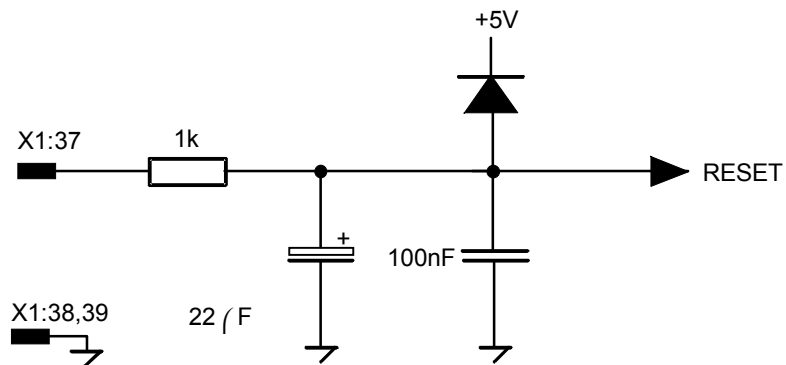

Fig. 4.8-9 Basic circuit diagram, digital input X1:37

4.8.5.2. Digital outputs

Digital outputs X1:7 ... X1:14 are not electrically separated (reference potential GND, X1:38 and X1:39). As standard, an external supply on X1:29 is intended for digital outputs X1:7 ... X1:14. The internal +15 V supply voltage is applied by setting jumper 501.

Attention! Do not set jumper 501, if external supply is applied to X1:29!

Technical data:

- Output voltage corresponding to the selected supply voltage
Max. output current: < 200 mA

The functions of the digital outputs refer to the active condition (Logic High) and standard software.

Attention! Only the function description supplied applies to special software!

X1:14	Drive active , final stage enabled and controllers are active
X1:13	Ready , no fault present
X1:12	Position reached
X1:11	Demand reached In position control the position is reached and in speed control the demand speed is reached
X1:10	Speed approx. zero , the motor speed is within the threshold set
X1:9	Overcurrent limit reached
X1:7, 8	Free , can be programmed with the application software

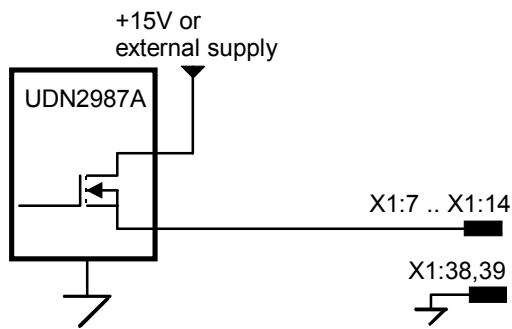

Fig. 4.8-10 Basic circuit diagram, digital outputs

Digital output X1:6 supplies the **synchronisation clock**. The signal is not decoupled!

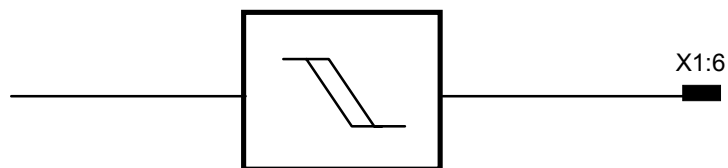

Fig. 4.8-11 Basic circuit diagram, synchronisation clock

4.8.6. Serial interfaces

4.8.6.1. Connection for RS485 network: Plug X3H

Hardware interface

- Standard EIA RS485 interface
- Fixed protocol: 8 data bits, 1 start bit, 1 stop bit, 19200 baud
- Screened and twisted cables must be used
- Cable length < 1200m
- Up to 32 bus users on one line
- Plug: 9-pin sub-D socket (female) on *digiVEC*, plug (male) on cable
- UNI310 protocol available

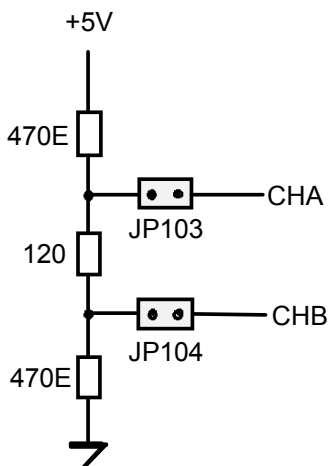

Attention!

5 V voltages may not be looped through several units.

Terminating resistors are installed as standard using jumpers JP103 and JP104. In multiple drive systems only the terminating resistors on the first and last units may be used. Jumpers JP103 and JP104 in all other units must be removed.

Fig. 4.8-12 Multiple drive operation

Plug wiring X3M:

1	+5 V
2	GND
3	Receiver/Transmitter CHA
4	-
5	GND
6	+5 V
7	GND
8	Receiver/Transmitter CHB
9	-

Connection for RS485 plug X8:

This connection is a circuit parallel to the RS485 network. The protocol and hardware interface are therefore identical.

Plug wiring X8:

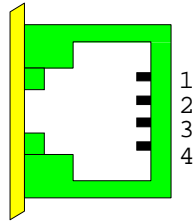

- | | |
|---|--------------------------|
| 1 | +5 V |
| 2 | Receiver/Transmitter CHA |
| 3 | Receiver/Transmitter CHB |
| 4 | GND |

4.8.6.2. Connection for PC at plug X3L

Hardware interface:

- Standard EIA RS232 interface
- Fixed protocol, 8 data bits, 1 start bit, 1 stop bit, 19200 baud
- Use screened and twisted cable
- Plug: 9-pin sub-D plug (male) on *digiVEC*, socket (female) on the cable

Plug wiring X3L:

1	DCD (Carrier Detect)
2	RXD (Receive Data)
3	TXD (Transmit Data)
4	DTR (Data Terminal Ready)
5	GND
6	-
7	RTS (Request to Send)
8	CTS (Clear to Send)
9	-

PC connection cable:

The connector on the control unit is a 9-pin sub-D male and the connector on the cable to the control unit is a 9-pin sub-D female. As standard the other end of the cable to the PC is either a 9-pin or 25-pin sub-D female connector. The length of the cable should not exceed 15 m.

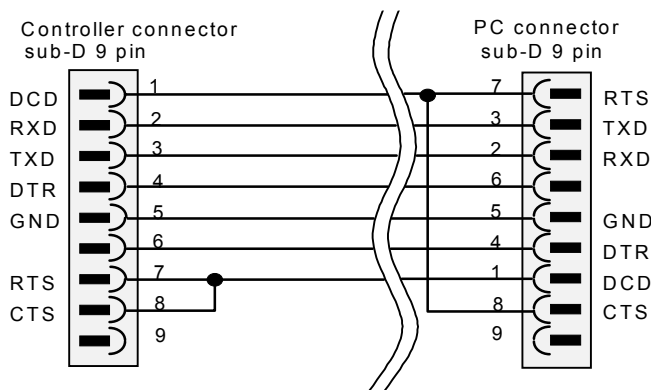

Fig. 4.8-13 Connection cable

5. Commissioning

The following sections give step-by-step instructions for commissioning the *digiVEC* and the motor used.

Please note: The user should follow the procedure in the sequence stated, to avoid faults or errors. Incorrect action during commissioning may damage the system (e.g. uncontrolled motor acceleration) If these instructions are not observed Contraves Antriebstechnik GmbH can accept no liability whatsoever for loss or damage.

The following are provided to assist with commissioning:

- The digiVEC configuration program
- Status indicators on the digiVEC front panel

Other equipment such as a (recording) oscilloscope for recording speed, torque, current, etc., a voltmeter and LED indicators for digital outputs are useful but not essential.

Only parameters which can be adjusted or must be adapted are mentioned below. Adjustment of any other parameters by the user is at his own risk (note the safety instructions!).

Start-up response

The external supply to the control electronics must first be switched on so that the processor can carry out its monitoring functions.

The DC bus voltage is generated when the mains voltage ($3 \times 400 V_{\text{eff}}$) is applied. If it exceeds the 400 V limit [**DCLINK_NOM (approx. %)**]; 400 V corresponding to 100%], the intermediate relay closes after a 3 second pause to allow the full charging current for the capacitor battery.

At the same time the resolver supply is generated through automatic calibration (LED 5 and LED 7 flash)

The controller is ready [LED 6 (green) is on] when this process is completed. The ready message is present as a voltage signal at terminal X1:13.

Shutdown response on voltage interrupt:

If the DC bus voltage falls below 340 V the drive is blocked. It is disabled and the intermediate relay is opened. This response is saved in battery-backed RAM so that restarting without first resetting after the fault is not possible.

Switching on as normal (as described above) is possible as soon as the fault is acknowledged through X1:21 (Reset). A reset is only possible when the controller is disabled.

Shutdown response during normal operation:

Firing is disabled when the motor reaches a standstill, to switch the unit off normally. If firing is switched off before the motor is at a standstill the inverter responds according to the activated AUX_FLAGS.

- **AUX_FLAG.0:** If firing is removed, the motor idles down
- **AUX_FLAG.5:** Fast stop through speed ramp setting (**DECEL** parameter)

If none of the two AUX_FLAGS is active the controller is braked using maximum braking current.

After "Firing off", the mains voltage can be switched off and the controller opens the intermediate relay as soon as the DC bus voltage falls below 340 V. Normal restarting is as described above.

5.1. Running the *digiVEC* configuration program

Connect the external (24 V) supply voltage according to section 4.6.

Connect the serial interface on the PC to terminal X3L on the *digiVEC*.

The *digiVEC* configuration program (the monitor program) is required for reading motor-specific parameters into the *digiVEC* controller. (A detailed description of the configuration program is given in section 4.1 *digiVEC* monitor program).

Call the program:	<i>start.bat</i>	Run program with English user interface
	or	
	<i>startger.bat</i>	Run program with German user interface

When communication is possible the parameter values are displayed in the configuration program.

The descriptions below refer to the English user interface.

Load the hex files into the controller:

The hex file supplied is always loaded into the RAM and FLASH memory before the controller can be put into operation.

Load the file into the inverter
RAM:

Select *Transfer* menu
Click and confirm *hexfile → ram*
Select and confirm hex file.
A loading routine will then start.

Load the file into the inverter
FLASH memory:

Select *Transfer* menu
Click and confirm *initram program → flash*
A loading routine will start, the LEDs on the controller will flash.
The hex file supplied is now in the Flash memory.

Note: In the configuration program it is possible to change between the individual memory areas using function keys F4 - F6.

5.2. Setting motor parameters

The motor data according to the rating plate must first be input into the relevant parameter field before the motor is operated.

5.2.1. POLE_SHIFT

This determines the ratio (motor no. of pairs of poles) : (resolver no. of pair of poles) and is input according to the following table:

Resolver no. of pairs of poles p_R	Motor no. of pairs of poles p_M	POLE_SHIFT
1	1	2048
1	2	4096
1	3	6144
2	2	2048
2	4	4096
3	3	2048

If the no. of pairs of poles ratio used is not shown in the table the value for **POLE_SHIFT** can also be calculated according to the following formula:

$$POLE_SHIFT = p_M / p_R \times 2048$$

The ratio between the no. of pairs of poles must produce a whole number.

5.2.2. BASE_SPEED

The **BASE_SPEED** parameter represents the rated speed according to the motor rating plate for a resolver with a single pair of poles and is to be entered in the appropriate field.

5.2.3. Speed limit

The speed limits are generally set to 10% higher than motor rated speed:

1st) **NMAX (rpm) = BASE_SPEED (rpm) + 10%**

2nd) **NMIN (rpm) = - NMAX (rpm)** Speed limit, reversing

5.3. Motor matching

It is not normally necessary to match the motor if the machine has been commissioned fully and correctly. However, if machine operation is disrupted during operation, manual adjustment as described below may provide a remedy.

5.3.1. Asynchronous motor

The parameters required for operating the motor must be set before calibration as described below (see section 5.2)

We recommend you note the new values for **IGAIN**, **FLUX** and **ROTRES_NOM** for later reference and keep them with the commissioning documentation.

Proceed as follows for the adjustment:

- 1.) **The motor must be able to rotate freely and be mechanically decoupled or at least without any mechanical limiting.**

The parameter below can only be edited in *initram*. Use function key F5 to switch from *work RAM* to *initram* at this point.

- 2.) **IAMAX:= 1000** 1000 corresponds to 1/3 of controller rated current in internal units (range 0 - 3000).
At IAMAX (%): Enter as a percentage value (an internal unit of 1000 corresponds to approx. 33% of controller rated current.
IAMAX: = 3000 corresponds to 100% of controller rated current)

Further motor matching: Switch from *initram* to *work RAM* using function key F6

- 3.) **ROTRES_NOM ≠ 0** e.g. ROTRES_NOM: = 1000 (basic setting)
- 4.) **NMUX_VEL to be set to NREF**
- 5.) **NREF: = 0** Demand at 0
- 6.) **CMDMUX: = CMDREF** Selected setting preferably switching firing on/off and reset through configuration program instead of through digital inputs.

-
- 7.) **CMDREF: = 00(Hex)** Firing off, controller disabled
 [CMDREF: = 01(Hex) Firing on, controller enabled or
 CMDREF: = 02(Hex) Reset (fault acknowledgement)
- 8.) **IAMUX: = NOUT** Switch the demand through (for speed control)
- 9.) **FLUX:** Use the value calculated with the instructions below. The value for magnetic field flux depends on the rated current of the controller and motor used. The field current is approx. 30% - 50% of motor rated current.
 Example: Motor rated current = 6 A → field current = 3 A (50%); controller rated current = 7 A (corresponding to 3000 internal units) **FLUX** = 3000 x 3 A / 7A = 1280
- 10.) **Automatic flux calibration:**
- 10.1) **CMDREF: = 01(Hex)** Firing on, controller enable
- 10.2) **NREF: =** Increase until **BASESPEED** is reached. (**POSSPEED = BASESPEED**)
- 10.3) **FLAG: = 20(Hex)** This activates automatic flux calibration (**FLUX**). Allow the motor to run at **BASESPEED** for approx. 10 s until the **FLUX** value no longer changes significantly.
- 10.4) **FLAG: = 00(Hex)** Reset the flag under section 10.3
- 10.5) **NREF: =** Reduce to 0 again in steps
- 10.6) **CMDREF: = 00(Hex)** Firing off, controller disabled
- 11.) **Current controller calibration:**
- 11.1) **CMDREF: = 01(Hex)** Ignition on, controller enable
- 11.2) **NREF: =** Increase up to **BASESPEED**
- 11.3) **IGAIN:** Check the current with the oscilloscope at test point 3 or 4 (see section 5.5.4 5.5.4). If distortion in the current characteristics occurs, adjust **IGAIN**: to compensate for the faults. **IGAIN** is to be set as high as possible.
- 11.4) **NREF: =** Reduce to 0 again in steps and set **CMDREF: = 00(Hex)**

- 12.) Rotor resistance calibration:
- 12.1) CMDREF:=01(Hex) Firing on
- 12.2) Flag:= 00(Hex)
- 12.3) NREF:= Adjust - **BASESPEED** and + **BASESPEED** in steps. Note the transition response in the speed characteristic on the oscilloscope (at speed output X1:34 on the *digiVEC*). A linear transition of the shortest possible duration is important. If the transition is not linear, **ROTRES_NOM** is too high. If the transition takes too long, **ROTRES_NOM** is too low. Optimum basic setting: 5 V. With this setting a step is made to -5 V on reversing. Reversing can be achieved by “tapping” the ↑ or ↓ keys once. For this, position the cursor in front of the figure 5 (_5.000). Note: Holding the key down for too long results in a double trigger (a doubling of speed).
- 12.4) NREF: = Reduce to 0 again in steps
- 12.5) CMDREF: = 00(Hex)

The following parameter can only be edited in the *initram*. Switch from *work RAM* to *initram* using function key F5 at this point.

- 12.6) IAMAX Reset according to application (max. 6000 internal units)

Switch from *initram* to *work RAM* using function key F6

This completes automatic self-calibration. All self-adjusting values are set and must now be saved in flash memory:

- 13.) Setting of POLL_FLAG.0 and FAST_FLAG.3 Set **POLL_FLAG.0** to deactivate automatic resolver calibration.
POLL_FLAG = 01H
FAST_FLAG.3 must be set to compare the parameters in work RAM with those in the flash memory after a system reset:
FAST_FLAG.3 = 04H
- 14.) Menu: Select Transfer and execute the following routines:
work RAM parameters → *initram*
initram program → *flash*
- 15.) RESET A unit reset (system reset) is forced through jumper X1:37 - X1:38 or by switching off the external 24 V DC or 18 V AC supply.

5.3.2. Synchronous motor

Attention! The motor must be mechanically decoupled and free to run.

The field current and rotor resistance for the synchronous motor are to be set to zero.
Field excitation through permanent magnet is required.

- 1.) **FLUX: = 0**
- 2.) **ROTRES_NOM: = 0**
- 3.) **SLIP_ANGLE: = 5350** If the number of motor pairs of poles $p_M = 3$ and the number of resolver pairs of poles is $p_R = 1$, this applies only the ACD series. Resolver adjustment is required with other synchronous motors (see section 1 below).
- 4.) **Current controller calibration:**
- 4.1 **IGAIN: = 2500 (preset)** Synchronous motors require a higher current gain than asynchronous motors
- 4.2 **CMDMUX:=CMDREF** The setting used allows firing to be switched on and off and a reset through the configuration program instead of through the digital inputs
- 4.3 **CMDREF: = 01(Hex)** Firing on, controller enable
- 4.4 **NREF: =** Increase to **BASESPEED**
- 4.5 **IGAIN:** IGAIN: Increase as long as the motor runs without vibrating
- 4.6 **NREF: =** Return to 0 again in steps and set **CMDREF: = 00(Hex)**

If the motor does not run without problems, adjust the resolver as described below:

- I.) **FLUX: = 0**
- II.) **ROTRES_NOM: = 0**
- III.) **IAMUX: = R0** Current controller input = 0
- IV.) **CMDMUX:=CMDREF** The setting used allows firing to be switched on and off and a reset through the configuration program instead of through the digital inputs
- V.) **CMDREF: = 01(Hex)** Firing on, controller enable
- VI.) **Set resolver:**

VI.I) IU_OFFSET and IV_OFFSET

Offset the “3-phase current balance” and simulate the load. Increase **IU_OFFSET** in steps of 100 up to +1000 in total. Reduce **IV_OFFSET** in steps of 100 to -500 in total. (Set the values in brackets to $< \pm 100 >$ using the cursor left or right keys. Then use cursor up or cursor down to increase or reduce the value accordingly). Attention: The motor will probably run and the shaft will align itself in a specific position. If the motor oscillates, this oscillation is to be damped (possible by hand). Read off **PACT_LOW** (in internal unit). If the value displayed exceeds 32767 it must be subtracted from 65536 or added to the figure if it is more negative than -32768. The motor shaft must remain at a standstill. Record the value resulting and compare with **SLIP_ANGLE**.

If the difference between the two values exceeds ± 500 units:

- VI.II) **SLIP_ANGLE: = -(value)** Negative value **PACT_LOW**
- VI.III) **CMDREF: = 00(Hex)** Firing off forces a reset for the value **IU_OFFSET** and **IV_OFFSET**
- VII.) **IAMUX: = NOUT**

Manual self-calibration is now complete. All self-adjusting values are set and must now be written into flash memory:

- 6.) **Setting of POLL_FLAG.0 and FAST_FLAG.3** Set **POLL_FLAG.0** to deactivate automatic resolver calibration:
POLL_FLAG = 01H
FAST_FLAG.3 must be set to compare the parameters in work RAM with those in the flash RAM after a system reset: **FAST_FLAG.3 = 04H**
- 7.) **Menu** Select **Transfer** and execute the following routines:
work RAM parameters → *initram*
initram program → *flash*
- 8.) **RESET** A unit reset (system reset) is forced through jumper X1:37-X1:38 or by switching off the external 24 V DC or 18 V AC.

5.3.3. Calibrate speed controller

5.3.3.1. Calibrate NGAIN_NOM of speed controller (without applying demand)

Attention! This facility for setting NGAIN_NOM without applying a demand may only be used with a synchronous motor after the motor has been matched. (see section 5.3.2, Synchronous motor).

- 1.) **NMUX_VEL (Addr): = NREF** Set demand multiplexer to internal demand input.
- 2.) **NREF (V): = 0** Demand = 0 (internal demand). The demand used for adjustment is set to 0. The motor is at a standstill.
- 3.) **CMDMUX (Addr): =CMDREF** Set command multiplexer to internal control via the PC.
- 4.) **CMDREF: = 01(Hex)** Firing is switched on
- 6.) **Increase NGAIN_NOM in small steps** (e.g. in steps of 10) until the motor vibrates.
- 7.) **Reduce NGAIN_NOM in small steps** (e.g. in steps of 10) until the motor no longer vibrates. (Hysteresis! The motor should be stable at this point).
- 8.) **CMDREF: = 00(Hex)** Firing is switched off

5.3.3.2. Calibrate **NGAIN_NOM** of speed controller (with demand applied):

Attention! This facility for setting **NGAIN_NOM** with demand applied may only be used after the motor is matched. (See section 5.3.2, Synchronous motor).

The effect of **NGAIN_NOM** can also be observed after a demand is applied (e.g. **NREF** = 1 V) on the oscilloscope. For this, the speed actual value (pin X1:34) is displayed on an oscilloscope. The following diagrams illustrate the effect of **NGAIN_NOM**:

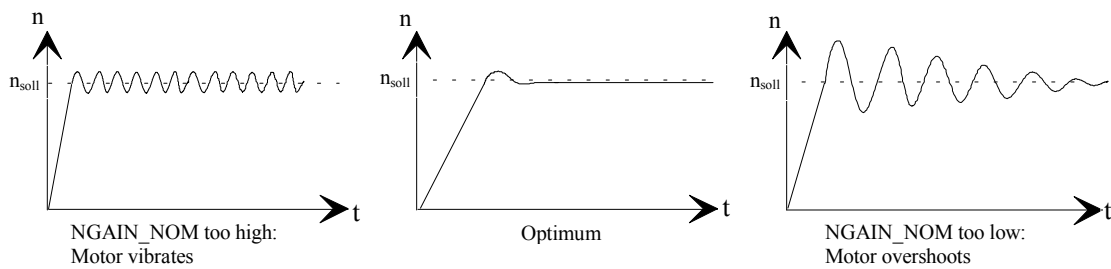

Fig. 5.3-1 **NGAIN_NOM**

To check the setting of **NGAIN_NOM**, repeat the application of the demand and evaluate the resulting speed characteristic on the oscilloscope. The speed actual value response should always be ideal.

If no stable motor position can be found with the method according to section 5.3.3.1 we recommend you check the value of **NTAU** and if necessary adjust according to the information given below.

5.3.4. Fine calibration of NTAU for speed controller

Normally the value of **NTAU** need not be adjusted.

However, if the setting of **NGAIN_NOM** according to section 5.3.3.1 or 5.3.3.2 creates problems so that no stable position can be found (the motor trips from vibrating to overshooting without passing through an optimum position), the value of **NTAU** must be adjusted.

Adjust **NTAU** as the first step: (Minimum values depending on hybrid)

- NTAU: = 0 150 Hz hybrid (indicated by the 0.22 μ F capacitor)
- NTAU: = 1 300 Hz hybrid (indicated by the 0.1 μ F capacitor)

If this value still does not allow a stable position, **NTAU** must be set by hand, i.e. adjusted in stages.

Begin with a low value for **NTAU** and increase **NTAU** in steps. After each increase, the setting of **NGAIN_NOM** must be adjusted again according to section 5.3.3.2. **NTAU** is increased until an optimum motor setting is found for **NGAIN_NOM**. (See Fig. 5.3-1 NGAIN_NOM)

5.4. Demand scaling

The demands for the speed and position controllers can be scaled with the following parameters:

Position controller: Parameter **RAP_POS, RAP_SHIFT_POS**

Speed controller: Parameter **RAP_VEL, RAP_SHIFT_VEL, RAP_SHIFT_RAMP**

5.5. Drive response to errors

digiVEC includes a self-diagnostics and monitoring system which responds to many errors which can occur during operation. The errors are indicated by LEDs on the *digiVEC* front panel.

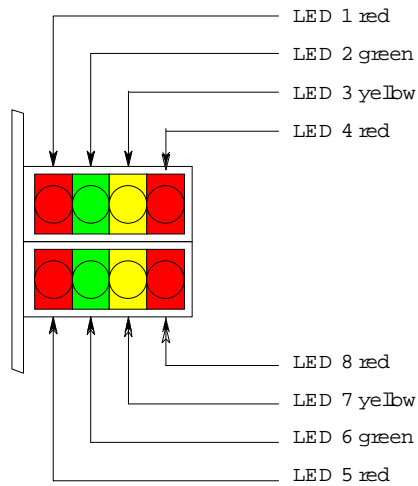

Fig. 5.5-1 LEDs

5.5.1. Function of LEDs on *digiVEC* front panel

The LEDs on the *digiVEC* front panel are numbered from 1 to 8. The indicators and their meanings are described below.

LED 1 (red) has a double function depending on drive enable:

- With the drive enabled LED 1 lights if the energy flowing back from the motor is converted into heat by the braking resistor.
- If the drive is disabled LED 1 flashes when there is no communication through the serial interface. The number of ON phases between two longer OFF phases corresponds to the station address of the drive on the communications network (default station address MYSTAD (hex.) is 80H).

LED 2, 3 and 4 indicate **errors during operation**.

If several errors occur simultaneously the first error to occur is displayed. This error is retained until a reset is made. A reset is made either by making digital input **X1:21 (Reset, fault acknowledgement)** and simultaneously breaking digital input **X1:22 (Controller enable)** with the motor at a standstill, through a jumper between terminals **X1:37 and X1:38/39 (System reset)** or by switching the external controller supply voltage off and on again.

After a reset the drive is in the "Ready" condition if the error was corrected. Otherwise the drive is "Not ready" (see LEDs 5 and 6).

LED 2 (green) on	Overspeed or blocking monitor
LED 3 (yellow) on	I x t limit reached. Overcurrent in power semiconductor (short circuit). Too rapid heat build-up in power semiconductor (overcurrent lasting several seconds).. Heatsink overtemperature (continuous operation).
LED 4 (red) on	Undervoltage
LED 5 and 6	Indicate the operating status of the drive.
LED 5 (red) on	Drive enabled
LED 6 (green) on	Drive ready
LED 7 (yellow)	On if the motor is at a standstill
LED 8 (red)	On if the drive has reached the torque limit and therefore regulation is no longer guaranteed. Torque limit is determined by parameter <i>I</i> AMAX.
LED 1, 4, 5 and 8	On if the supply voltage for DAM card and fan is too low.

5.5.2. Errors during operation

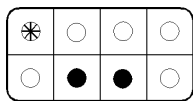

LED 1 flashing, LED 6 and 7 on
No communication possible via the serial interface. (If firing is enabled, LED 5 is on in addition).

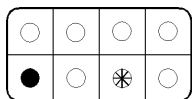

LED 5 on, LED 7 flashing
Resolver signal missing, resolver signal is being searched.
 Defective resolver connection, wiring, resolver, or resolver processing (hybrid module).

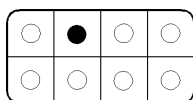

LED 2 on
Overspeed: Motor speed (**POSSPEED**) exceeds positive or negative speed limit given by **NMAX** and **NMIN** or the blocking monitor: Mechanical block (stop) or drive overloaded, value of parameter **NGAIN** incorrect.

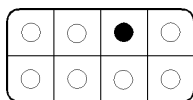

LED 3 on
I · t limit reached: Permitted current time characteristic exceeded. Drive overloaded.

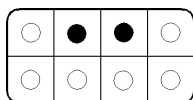

LED 2 and 3 on
Overcurrent: Permitted peak current exceeded. Short circuit or earth fault on motor cable or in motor itself.

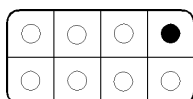

LED 4 on
Undervoltage: Mains voltage missing or too low. Check fuse.

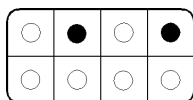

LED 2 and 4 are on
Overtemperature: Permitted overtemperature exceeded. Drive overloaded, unsatisfactory cubicle ventilation.

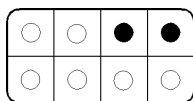

LED 3 and 4 on
Overvoltage: Permitted link voltage exceeded. This error mostly occurs if permitted braking capacity is exceeded.

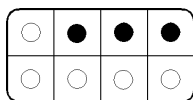

LED 2, 3 and 4 on
Fault with digital outputs: Overload, short circuit or overvoltage at binary outputs X1:7 ... X1:14.

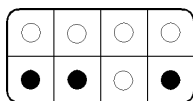

LED 5, 6 and 8 on
Phases reversed at motor:
 Asynchronous motor: Running slowly (slip speed). Speed cannot be adjusted.
 Synchronous motor: Does not run.

5.5.3. Operating conditions

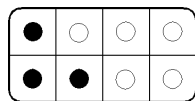

LED 1, 5 and 6 on

Energy feedback: Energy flowing from motor is converted into heat by braking resistor. (Firing enabled).

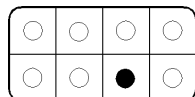

LED 7 on

Drive blocked, motor at a standstill: If digital input X1:22 (controller enable, firing on) is closed before supply voltage is applied. Or when an error occurs during operation (see description of LEDs 2, 3 and 4) when drive is enabled. Or after voltage failure.

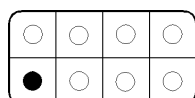

LED 5 on

Drive not ready: At least one error is present after a reset. If an attempt is made to enable the drive it switches to the blocked condition. As soon as the error is corrected the drive switches to the ready condition without another reset.

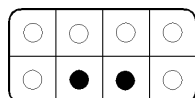

LED 6 and 7 on

Drive ready: Drive can be enabled through digital input X1:22 (controller enable, firing on). If an error occurs before drive is enabled it switches to "Not Ready".

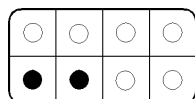

LED 5 and 6 on

Drive enabled: In this condition the power final stage is active, i.e. current flows through the motor and the motor is running. If an error occurs the drive switches to the blocked condition (If motor stands still, LED 7 is on in addition).

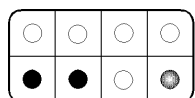

LED 5 and 6 on, LED 8 on during starting and braking

Current limit reached: Drive reached the current or torque limit. Speed regulation no longer guaranteed. Check the mechanical parts of the drive and parameter **IAMAX**.

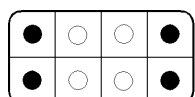

LED 1, 4, 5 and 8 on

Fault on internal 5 V power supply: Supply voltage for fan and DAM card too low, 5 V power supply overloaded. Check external circuitry at terminal X1:40.

Legend:

- *LED on*
- *LED off*
- ⊗ *LED flashing*
- *LED lights briefly and goes off again*

5.5.4. Test points on unit

Four test points are provided on the *digiVEC* front panel. The signals present can be checked with an oscilloscope. Test points 1 to 4 give access to the following signals:

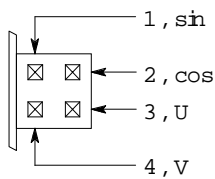

Fig. 5.5-2 Test points

- | | | |
|------|-----------------|--|
| 1st) | Resolver sine | $\pm 6.5 \text{ V}$ |
| 2nd) | Resolver cosine | $\pm 6.5 \text{ V}$ |
| 3rd) | Phase current U | $\pm 8.5 \text{ V}$ corresponding to $\pm 2 \times I_{\text{rated}}$ |
| 4th) | Phase current V | $\pm 8.5 \text{ V}$ corresponding to $\pm 2 \times I_{\text{rated}}$ |

In addition, digital and analog outputs are available at plug X1 for checking the function:

Only a few are mentioned at this point, for example:

- X1:14 Digital output Power On
- X1:13 Digital output Ready
- X1:33 Analog output Speed control fault
- X1:34 Analog output Speed actual value

5.6. *digiVEC* operating parameters

The parameters assigned to certain fields (standard user interface) below can in practise also be located in other fields.

Speed controller field

INCSPEED (rpm) =	Speed demand preset
POSSPEED (rpm) =	Speed actual value
NMAX (rpm):	Max. speed of motor, forward, speed limit
NMIN (rpm):	Max. speed of motor, reverse, speed limit
NTAU:	Hybrid time constant, speed controller gain (I component)
NGAIN_NOM:	Speed controller gain (P component)
FEEDFWD:	Dynamics
NOUT	Speed controller output
SPEED_DELTA	Speed difference
SCALE_SPEED	Scaling the analog speed output signal
SPEED_OFFSET	Offset value for analog speed output signal
N_EPS	Dead time processing for motor standstill signal at terminal X1:10

Command field

CMDMUX (Addr):	Multiplexer, allows access for selection, e.g. through the configuration program (CMDREF) or (input) through digital inputs
CMDREF:	Control of digital inputs X1:15 ... X1:22 through configuration program
INPUT=	External control of digital inputs X1:15 ... X1:22

Current controller field

IAMAX (%) :	Current limit, max. output current in % of rated controller current
IARM (%) =	Actual motor current as % of rated controller current
IGAIN:	Current controller gain
SCALE_COPPIA:	Torque processing
COPPIA =	Actual torque
VOLT_A	Motor voltage
VOLT_F	Field voltage with asynchronous motor
IA_ACT =	Motor current, actual armature current (values based on IAMAX)
IF_ACT =	Field current with asynchronous motor, actual idling current (values based on IAMAX)
COPPIA_OFFSET	Offset value of analog current output signal (torque)
RAP_IARM:	Scaling of current controller input

Motor parameters field

IAMUX (Addr):	Multiplexer, current controller input. Facility for selecting control: e.g. (NOUT(Addr)) allows speed control or (NREF) allows current control
FLUX:	Flux setting, e.g. flux = 0 with asynchronous motor
ROTRES_NOM:	Rotor resistance of drive motor (basic setting = 1000)
POLE_SHIFT:	Value: (No. of pairs of poles in motor / No. of pairs of poles in resolver) x 2048 (see section 5.2.1)
RES_ANGLE_INIT:	Start resolver
SLIP_ANGLE:	Resolver adjustment, slip angle (is required for correct setting of synchronous motor)
BASE_SPEED (rpm):	Transition point, field weakening, with asynchronous motor (transition speed)
IU_OFFSET:	Together with IU_OFFSET : Adjustment allows offset of 3-phase AC current balance and thus simulates a load
IV_OFFSET:	Together with IU_OFFSET : Adjustment allows offset of 3-phase AC current balance and thus simulates a load
Scale_sin:	Scaling the resolver sinusoidal signal
Scale_cos:	Scaling the resolver cosine signal

FLAGS field

FLAG (bin):	Flag setting, e.g. switching to position control, activating automatic flux setting (Flag: 20Hex). See flag list for further details.
FLAG_VEL (bin):	The value set here (8 bit) is taken over in FLAG (bin) : when firing is switched on. FLAG_VEL (bin) : is only operational if digiVEC is set to speed control.
AUX_FLAG (bin):	See flag list for flag settings
APPL_FLAG (bin):	See flag list for flag settings
FLAG_POS (bin):	The value set here (8 bit) is taken over in FLAG (bin) : when firing is switched on. FLAG_POS (bin) : is only operational if digiVEC is set to position control
POLL_FLAG (bin):	For flag settings please refer to section 0 Function of individual flags

Demand input field

NMUX_VEL (Addr):	Speed controller multiplexer, selection facilities. e.g. (ANCHA1) analog demand input, (NREF) computer-controlled demand
ANCHA1 (V) =	Analog input
ANCHA2 (V) =	Analog input
NREF (V):	Preset reference speed (NMUX_VEL: = NREF) through the computer used
ANCHA1_FILTER:	Filter setting for analog input ANCHA_1
ANCHA2_FILTER:	Filter setting for analog input ANCHA_2
RAP_VEL (rpm/V):	Scaling of input demand present at NMUX_VEL (Addr):
RAPPORTO (rpm/V):	Scaling the input demands when firing is ON. If firing is switched off again, the value of RAP_VEL or RAP_POS is set according to the control used.
RAP_SHIFT_VEL:	Scaling (doubling) the input demand present
IERR_LIM:	Threshold for short circuit detection
OUTPT_IMAG:	Simulation of digital outputs
UPPER_BASE	Speed at which IAMAX is reduced

Ramp field

ACCEL (rpm/s):	Acceleration ramp
DECEL (rpm/s):	Braking ramp
PERR_MAX (rpm):	Max. drive speed for positioning
NREF_EPS:	Dead time, analog processing
NRAMP:	Ramp, speed demand
ACCEL_SHIFT:	Damping of harmonics during acceleration (0 = greatest damping)
DECEL_SHIFT:	Damping of sub-harmonics on braking (0 = greatest damping)
RAP_SHIFT_RAMP:	Scaling (doubling) the input demand present

Link/Brake chopper field

DCLINK (V) =	Actual link voltage
DCLINK_NOM (ca. %)	Nominal link voltage
Brake_Chopper_off (V):	Switching threshold for brake chopper off
Brake_Chopper_on (v):	Switching threshold for brake chopper on
undervolt_cnt:	Time (1 = 50 ms) after which controller restarts after undervoltage error message without error acknowledgement (reset)
Relay_Delay (sec):	Delay time between reaching nominal link voltage and shutdown of charging resistors

Position field

NMUX_POS (Addr):	Input multiplexer, position controller. Selection options, e.g. (NREF) computer-controlled demand, (ENC_DELTA:) encoder signal
RAP_POS:	Scaling the input demand present at NMUX_POS (Addr):
RAP_SHIFT_POS:	Scaling (doubling) the input demand present
ORIENT_POS:	Position preset for spindle positioning
PACT_LOW =	Actual position of shaft (65536 -> 360°)
PACT_HIGH:	Actual position of shaft (in revolutions)
PTAU:	Position controller gain (P component)
POUT	Position controller output
DASRC1:	Assignment of analog output X1:36
DASRC2:	Assignment of analog output X1:35
ENC_LINES:	See Encoder simulation for description
POS_EPS	Window: Position reached

5.7. Function of individual flags

Flags cannot be switched individually but only as a group (8 bit) with a hexadecimal number. The values of the individual bits must be added. The resulting value is then input.

FLAG (bin)	Function	HEX No.
FLAG.0	Encoder for position feedback	01H
FLAG.1	POS controller	02H
FLAG.2	FEED FORWD (FLAG.1=1); VEL_RAMP (FLAG.1=0)	04H
FLAG.3	No I component in speed controller	08H
FLAG.4	Encoder input active	10H
FLAG.5	Flux control, flux value retained	20H
FLAG.6	Encoder simulation active	40H
FLAG.7	Filter for resolver angle measurement activated	80H

Example: Simultaneous optimisation of rotor resistance and blocking monitor:

$$\begin{array}{r}
 \text{FLAG.6} \quad 40\text{H} \\
 \text{FLAG.7} \quad +80\text{H} \\
 \hline
 \text{FLAG} \quad \underline{\underline{C0\text{H}}}
 \end{array}$$

AUX_FLAG (bin)	Function	HEX No.
AUX_FLAG.0	Firing disabled immediately when enable removed	01H
AUX_FLAG.1	Not used	02H
AUX_FLAG.2	Not used	04H
AUX_FLAG.3	Synchronous running	08H
AUX_FLAG.4	Limit switch as reference point (X1:2 and X1:5)	10H
AUX_FLAG.5	Fast stop through ramp	20H
AUX_FLAG.6	Indexing	40H
AUX_FLAG.7	Register mark as reference point (X1.3/4)	80H

APPL_FLAG (bin)	Function	HEX No.
APPL_FLAG.0	Spindle positioning through reference mark	01H
APPL_FLAG.1	Spindle positioning	02H
APPL_FLAG.2	Offset calibration for ANCHA to external signal	04H
APPL_FLAG.3	Limit switch monitor	08H
APPL_FLAG.4	SSI link enable	10H
APPL_FLAG.5	Spindle orientation through adjuster enable	20H
APPL_FLAG.6	Not used	
APPL_FLAG.7	<p>= 0 ANCHA2 is read in from terminal X1:25/26 ANCHA1 is read in from terminal X1:27/28 ANCHA2 should be used as speed reference value Jumper from X1:23 to X1:38 or from X1:23 to X1:39</p> <p>= 1 ANCHA2 is read in from terminal X1:27/28 as a highly stable numerical value Jumper from X1:23 to X1:38 or from X1:23 to X1:39, jumper from X1:30 to X1:35</p>	80H

POLL_FLAG (bin)	Function	HEX No.
POLL_FLAG.0	Automatic resolver calibration not active	01H
POLL_FLAG.1	Amplitude calibration of sine and cosine resolver signals active	02H
POLL_FLAG.2	Automatic offset calibration for ANCHA1 (internal)	04H
POLL_FLAG.3	Automatic offset calibration for ANCHA2 (internal)	08H

FAST_FLAG (bin)	Function	HEX No.
FAST_FLAG.0	Overload shutdown active	01H
FAST_FLAG.1	Only blocking monitor active FAST_FLAG.0 = 1	02H
FAST_FLAG.2	Blocking power error input	04H
FAST_FLAG.3	Initialisation values loaded from flash memory	08H

SPEC_FLAG (bin)	Function	HEX No.
SPEC_FLAG.0	Second 8 kHz crossover	01H
SPEC_FLAG.1	Enable PWM	02H
SPEC_FLAG.2	Blocking power error input	04H
SPEC_FLAG.3	Highly stable input ANCHA2 activated	08H
SPEC_FLAG.4	IAMUX = # NOUT	10H

Resolver status	Function	HEX No.
RES_STATE.0	Resolver phase and amplitude setting	01H
RES_STATE.1	Resolver phase and amplitude setting	02H
RES_STATE.2	Resolver phase and amplitude setting	04H
RES_STATE.3	Resolver calibration on first pass	08H
RES_STATE.4	Within POS_EPS	10H
RES_STATE.5	Above ROT_EPS	20H
RES_STATE.6	Below N_EPS	40H
RES_STATE.7	Current limiting	80H

Operating status	Function	HEX No.
STATE.0	1: = STATE_OFF; 2: = STATE_BLOCK	01H
STATE.1	2: = STATE_READY; 3: = STATE_ON	02H
STATE.2	Not at low speed	04H
STATE.3	Not used	08H
STATE.4	Max. unit speed overwritten	10H
STATE.5	In ramp	20H
STATE.6	Speed reached => speed constant (ramp)	40H
STATE.7	Standstill	80H

Application status	Function	HEX No.
APPL_STATE.0	0: = Speed control; 1: = transition from speed to position control	01H
APPL_STATE.1	2: = Position control	02H
APPL_STATE.2	Further application conditions	04H
APPL_STATE.3	Data entry active	08H
APPL_STATE.4	Above BASE_SPEED	10H
APPL_STATE.5	Not used	20H
APPL_STATE.6	Not used	40H
APPL_STATE.7	Overtemperature	80H

6. Jumper

6.1. Jumper setting

JP	Standard	Jumper	Reference, page
101	not fitted	1 2	Connects input P2.6 (pin 33 of D104) to reference potential
102	fitted	1-2	Connects signal EA (D104) to reference potential
103	fitted	1-2	Cable terminating resistors set for third serial interface
104	fitted	1-2	Cable terminating resistors set for third serial interface
105	fitted	1 2-3	Connects signal Q (D107) to SH5-A1
106	not fitted	1 2	Connects EXTC signal to reference potential
107	fitted	1-2	Jumper for battery-buffered RAM
301	not fitted	1 2 3	-
401	not fitted	1 2 3	-
402	not fitted	1 2 3	-
403	not fitted	1 2 3	-
404	fitted	1-2	Must be connected if internal encoder supply +5 V is used (X1:1)
501	fitted	1-2	With jumper set, digital outputs (X1:7 ... X1:14) are supplied internally with +15 V
502	not fitted	1 2	Connects pin 2 (D507) to reference potential
601	fitted	1-2	Internal voltage supply (+15 V) available
602	fitted	1-2	Internal voltage supply (-15 V) available
603	fitted	1-2	Internal voltage supply (+ 5V) available
604	fitted	1-2	Connects controller electronics reference potential to operating earth (BE)
605	fitted	1-2	Connects BE (operating earth) to plug casings at connections points X2H, X2L, X3H and X3L

6.2. Jumper locations on DAM card

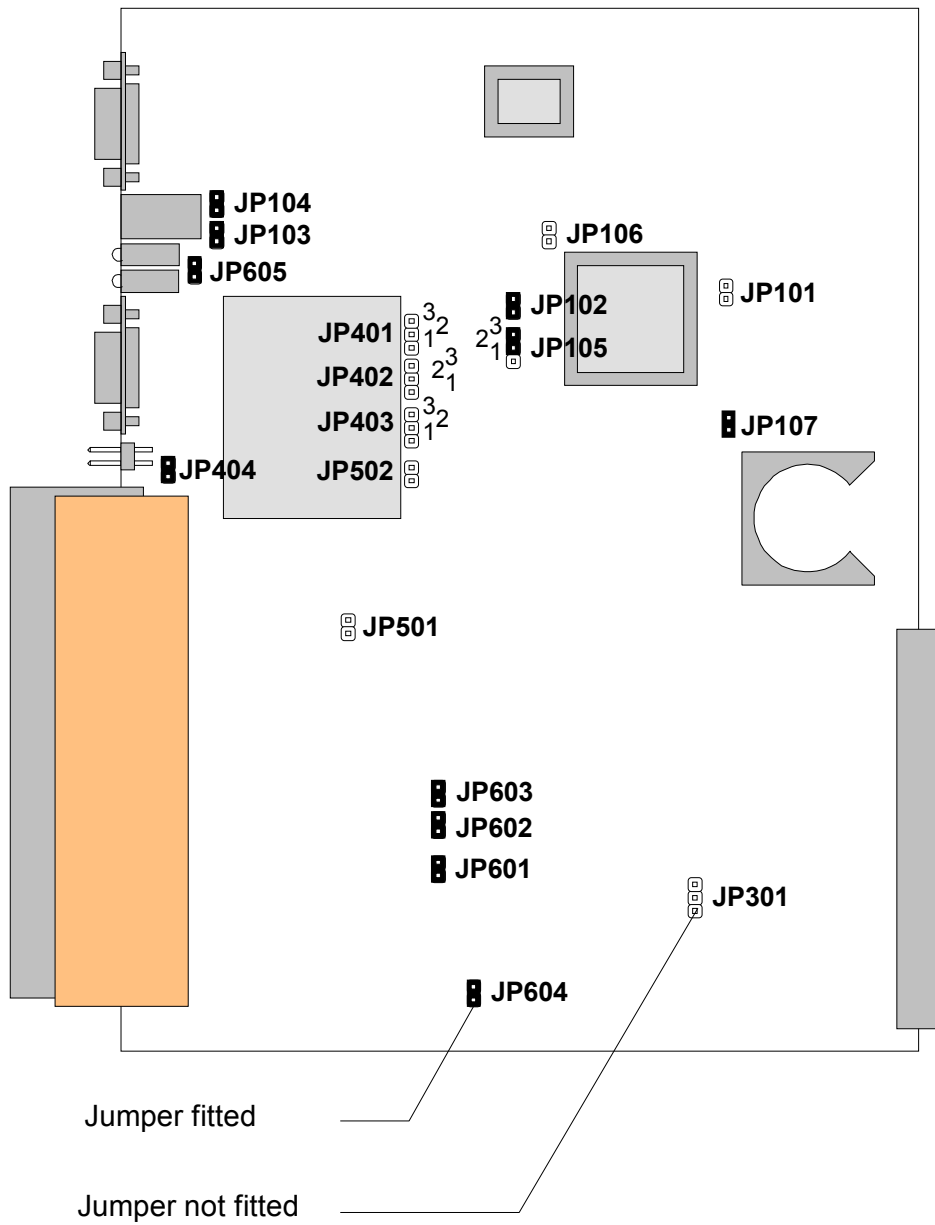

Fig. 6.2-1 Jumpers on DAM card

7. Installation dimensions

7.1. Installation dimensions for DAC4, DAC7 and DAC11: (All dimensions in mm)

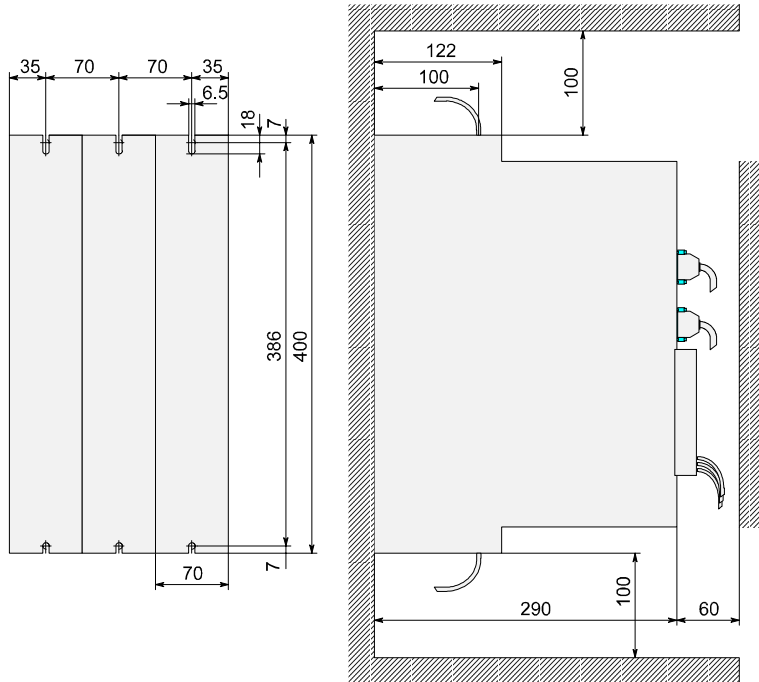

Fig. 7.1-1 Installation dimensions: DAC 4, 7, 11

7.2. Installation dimensions for DAC18 and DAC28: (All dimensions in mm)

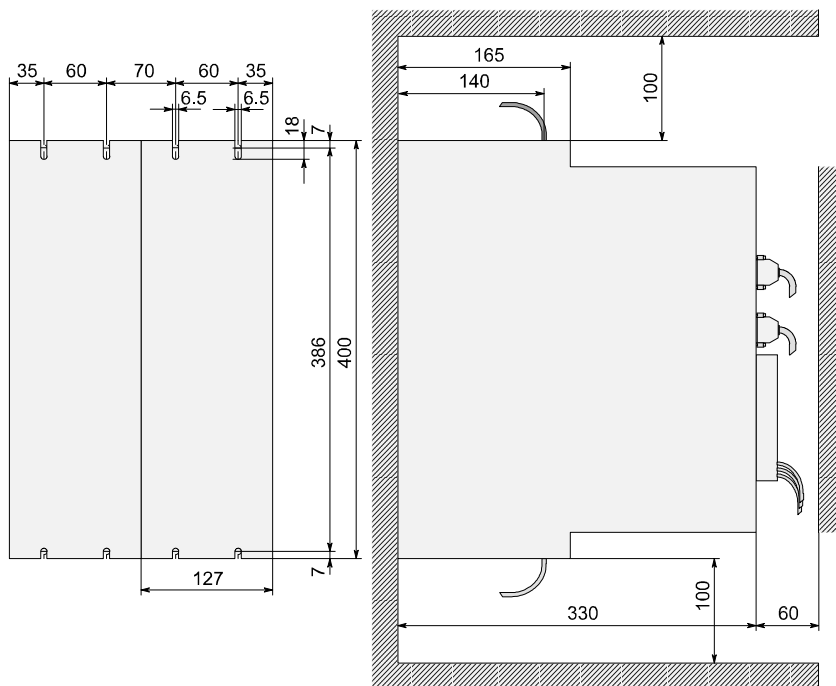

Fig. 7.2-1 Installation dimensions: DAC 18, 28

7.3. Installation dimensions for DAC60 and DAC80: (All dimensions in mm)

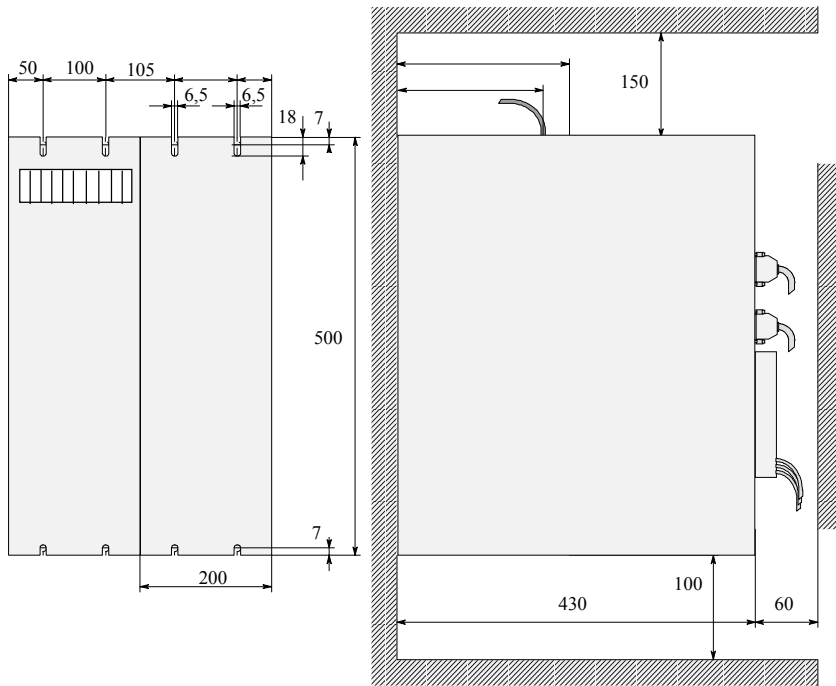

Fig. 7.3-1 Installation dimensions: DAC 45, 60, 80

8. Motor connection wiring

8.1. ACD synchronous motors

8.1.1. Using plug connector

8.1.1.1. Series: ACD 07, ACD 09, ACD 11

Connection for thermal switch (2 x 0.75 mm²):

Connector pin	Cable
C	white
D	green

Motor connection (4 x 2.5 mm²):

Connector pin	Cable	Connection on digiVEC
GND	green/yellow	BE
3	3	W
4	2	V
1	1	U

(Viewed from solder side)

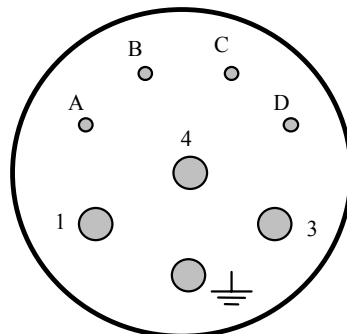

Fig. 8.1-1 Motor plug ACD 07/09/11

Terminals **A** and **B** not used

8.1.1.2. Series: ACD 14, ACD 19

Connection for thermal switch (2 x 0.75 mm²):

Connector pin	Cable
1	white
2	green

Motor connection (4 x 6 mm²):

Connector pin	Cable	Connection on digiVEC
GND	green/yellow	BE
U	3	W
V	2	V
W	1	U

(Viewed from solder side)

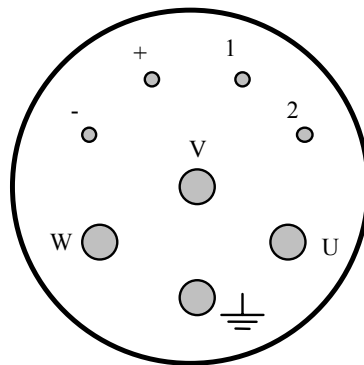

Fig. 8.1-2 Motor plug ACD 14/19

Terminals - and + not used

8.1.2. With terminal box

Connection for motor:

Connector pin	Cable	Connection on digiVEC
GND	green/yellow	BE
U	1	U
V	2	V
W	3	W

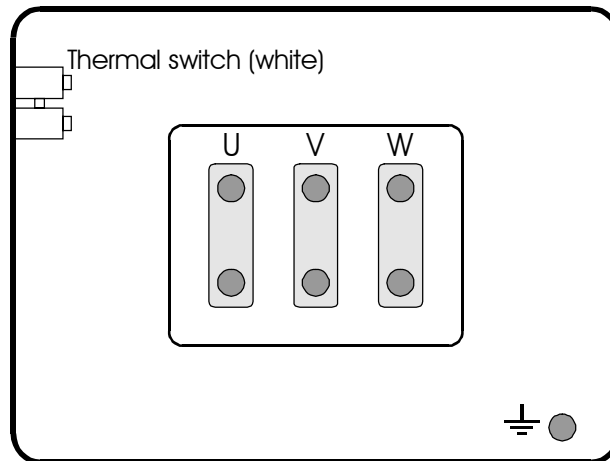

Fig. 8.1-3 Terminal box, ACD motors

8.1.3. Connection for brake (every ACD series)

Connector pin	DC voltage
A	+ 24 V
B	0 V

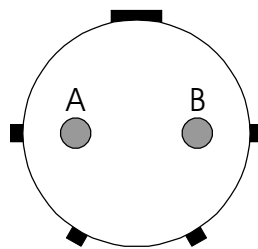

Fig. 8.1-4 Brake, ACD motors

8.2. CAS asynchronous motors

CAS asynchronous motors are supplied with terminal boxes as standard. On request, however, these motors can also be supplied with plug connectors.

Series: **CAS 100**
 CAS 132

8.2.1. With terminal box

Connection for motor:

Connector pin	Cable	Connection on digiVEC
GND	green/yellow	BE
U1	1	U
V1	2	V
W1	3	W

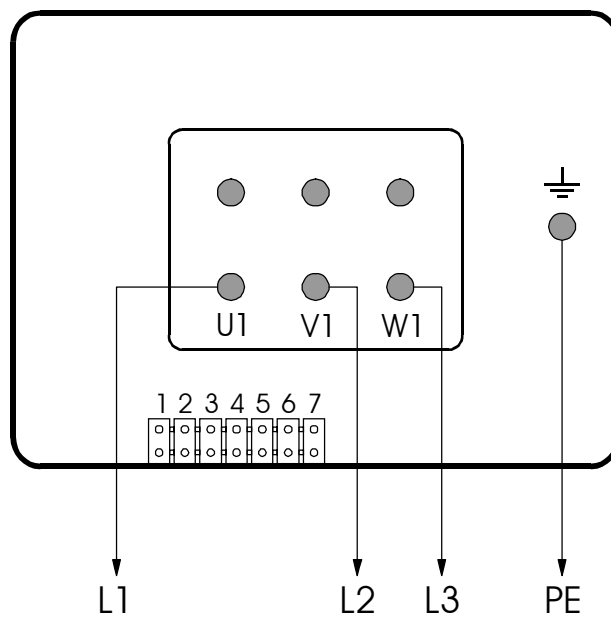

Fig. 8.2-1 Terminal box, CAS motors

8.2.2. With plug connector

Connection for external fan (2 x 2.5 mm²):

Plugs:

Connector pin	Cable	Mains connection
GND	green/yellow	PE
3	3	L3
4	2	L2
1	1	L1

(Viewed from solder side)

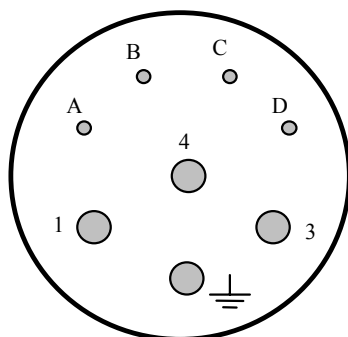

Fig. 8.2-2 Fan plug

Terminals **A**, **B**, **C**, and **D** not used

Motor connection (4 x 6 mm²):

Plug:

Connector pin	Cable	Connection on digiVEC
GND	green/yellow	BE
U	1	U
V	2	V
W	3	W

(Viewed from solder side)

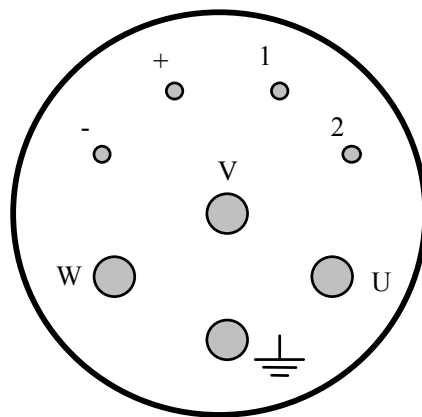

Fig. 8.2-3 Motor plug, CAS motors

Terminals +, -, 1, and 2 not used

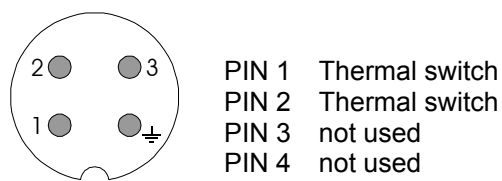

Fig. 8.2-4 Plug connector for thermal switch

8.3. CAD asynchronous motors

Series CAD 71

Connection for motor and thermal switch

Connector pin	Cable	Connection on digiVEC
GND	green/yellow	BE
U	1	U
V	2	V
W	3	W

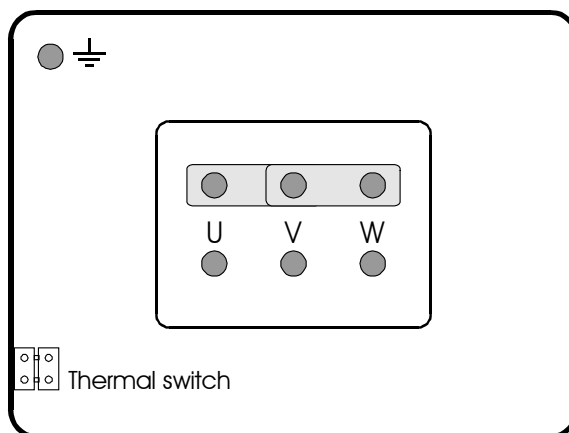

Fig. 8.3-1 Terminal box CAD 71

Series CAD 80
 CAD 90

Connection for motor and thermal switch

Connector pin	Cable	Connection on digiVEC
GND	green/yellow	BE
L1	1	U
L2	2	V
L3	3	W

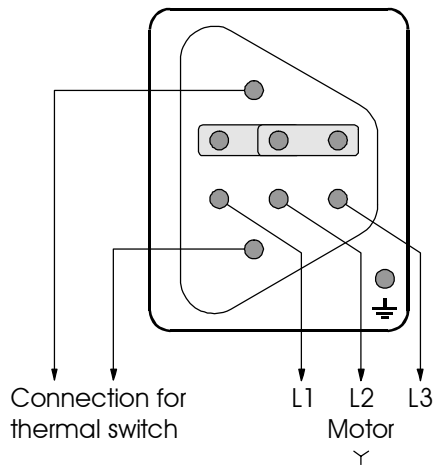

Fig. 8.3-2 Terminal box CAD 80/90

Fan connection

Terminal	Mains connection
GND	PE
U1	N
U2	L1

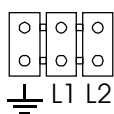

Fig. 8.3-3 Fan connection

Series **CAD 100**

Connection for motor and thermal switch

Terminal	Cable	Connection on digiVEC
GND	green/yellow	BE
L1	1	U
L2	2	V
L3	3	W

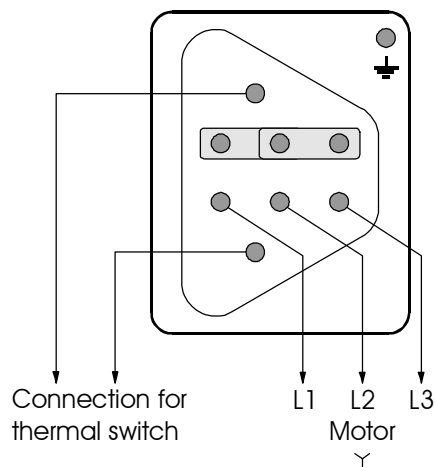

Fig. 8.3-4 Terminal box CAD 100

Fan connection

Terminal	Mains connection
GND	PE
U1	L1
V1	L2
W1	L3

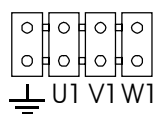

Fig. 8.3-5 Fan connection

Series CAD 112

Connection for motor and thermal switch

Terminal	Cable	Connection on digivec
GND	green/yellow	BE
L1	1	U
L2	2	V
L3	3	W

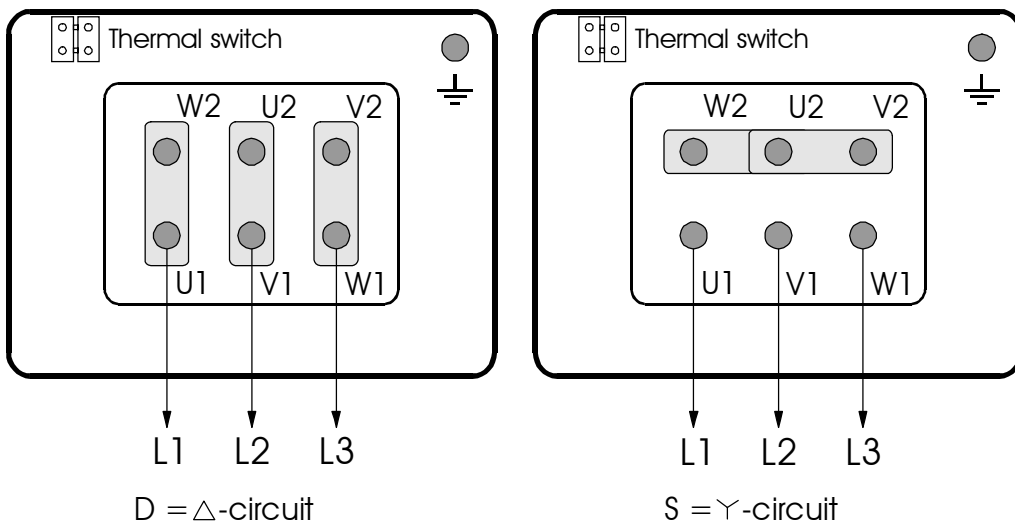

Fig. 8.3-6 Circuit diagram, terminal box CAD 112

The circuit required for your motor is indicated by its rating plate.

Fan connection

Terminal	Mains connection
GND	PE
U1	L1
V1	L2
W1	L3

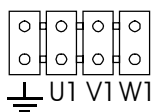

Fig. 8.3-7 Fan connection

9. Information for ordering

9.1. Cables and plug connectors

Designation	Article Number
Connectors for resolver connection on motor	
Angled resolver plug KPT08F12-10S	E315401008
Straight resolver plug KPT06F12-10S	E315401007
Socket for resolver connection for installation in motor KPT02E12-10P	E315401012
Resolver cable without plug (state length)	E133010045
Resolver cable complete including connector (Special lengths available on request)	
3 m, straight connector ⁽¹⁾	E315401028
5 m, straight connector ⁽¹⁾	E315401021
3 m, angled connector ⁽¹⁾	E315401024
5 m, angled connector ⁽¹⁾	E315401025
Resolver plug to controller sub-D, 9-pin female without casing	E133020022
Encoder plug to controller sub-D, 9-pin male without casing	E133020012
Metal casing for sub-D 9-pin plug	E133020037
Motor power connector	
6,0 mm ² straight - socket	E315401015
2,5 mm ² straight - socket	E315401013
2,5 mm ² angled - socket	E315401017
6,0 mm ² - plug	E315401014
2,5 mm ² - plug	E315401016

⁽¹⁾ suitable for cable drag

Special lead for motor connection	
4 x 2.5 + 2 x (2 x 0.5) screened ⁽¹⁾	E133010042
4 x 6.0 + 2 x (2 x 0.5) screened ⁽¹⁾	E133010043
Standard Oelflex cable	
4 · 1,5 mm ²	E133010040
4 · 2,5 mm ²	E133010038
4 · 4,0 mm ²	E133010034
4 · 6,0 mm ²	E133010036

9.2. Mains filters, filters for controller electronics supply voltage

Designation	Article Number
Mains filter for controller type	
DAC 4	E600200010
DAC 7	E600200015
DAC 11	E600200020
DAC 18	E600200030
DAC 28	E600200040
DAC 60	E600200050
Filter for controller electronics (24V), all controller types	
DAC	E600250010

The filters stated comply with interference suppression Class A (EN 50082-2/95).

Filters for compliance with Class B are available on request from Contraves Antriebstechnik GmbH.

9.3. Address for orders

Consysta Automation GmbH /
contraves drives
Am Saegewerk 23A
D-55124 Mainz-Gonsenheim

GERMANY

Tel.: +49 6131 9469 - 0

Fax: +49 6131 9469 - 13

E-Mail: email@contraves-drives.com

Internet: <http://www.contraves-drives.com>

10. Index

A

Screening and interference suppression	49
Fuses for electronic circuits	58
Analog outputs	65
Analog inputs and outputs	63
Connection for PC	72
Asynchronous motor	79
Shutdown response	74

B

Frame size	35
User interface	43
Intended use	32
Faults during operation	92
Operating parameters	95
Operating conditions	93
Reference potential	68
Block circuit diagram	15
Braking resistors	56

D

Continuous braking capacity	56
Differential analog inputs	63
Digital outputs	68
Digital inputs and outputs	66
Digital inputs	66
Speed limiter	77
Speed control	25
Speed controller	84; 86
Calibrate speed controller	84
3-phase bridge rectifier	18

E

EU Declaration of Conformity 96	37
Input test	36
Switching on	36
Start-up response	73
Setting motor parameters	76
EMC Guidelines	34
Encoder	19
Encoder connection	60
Encoder simulation	31
Encoder supply	61
External supply voltage	57

F

Fault	89
Field excitation	82
Field weakening	33
Humidity class	33
Front view	13
Function of individual flags	103
Function of LEDs	90

G

Dangers	9; 32
Unit description	17
Unit data	35

H

Hardware interface	70
Help system	45
Ancillary equipment	73

I

Commissioning	73
---------------------	----

K

Terminal block X1	62
Configuration program	44
Run configuration program	75
Coordinates transformation	29

L

Position control	26
Power connection	52
Performance summary	35
Airflow	34

M

Restricted actions	9
Monitor program	40
Motor and power connections	49
Motor matching	79
Motor connection	51
Multiplexer	20

N

Rated power	35
Rated current	35
Mains connection	33
Mains fuse	35
Mains voltage	56
Network	33; 70
Emergency-Off equipment	9

P

Parameters	23
Personnel protection	9
Pulse inverter	29
Pulse width modulation	29

R

Control	25
Controller characteristics	12
Relative humidity	34
Resolver	19
Resolver connection	59

RS485	71
RS232	72
Feedback facilities	19
Feedback systems	59

S

Switching level	66; 67
Switchgear cubicle mounting	50
Interfaces	57
Protection class	33
Serial interfaces	70
Safety and application instructions	2
Safety conditions	9
Fuses	58
Signal leads	55
Application of demands	85
Scaling demands	87
Demand preset for position controller	27
Special function of position control	27
Voltage link	18
Memory areas	30
Faults	34
Current control	25
Synchronisation clock	69
Synchronous motor	82
System reset	30; 81

T

Switching frequency	33
Teach in procedure	28
Technical data	33
Test points	94

U

Ambient conditions	34
Ambient temperature	33
Conversion of internal units	25
Unipolar analog output	64

V

Connection cable to PC	72
Wiring	47
Power loss	34
Regulations	9; 34

W

AC voltage	57
------------------	----

Z

Supply cable cross-section	52; 53
Ancillary equipment	33
Optional equipment	12
Link circuit	33
Link voltage	56

11. Space for notes

