

EtherCAT – Ultra high-speed for automation

Highlights

- Ethernet up to the terminal – complete continuity
- Ethernet process interface scalable from 1 bit to 64 kbyte
- first true Ethernet solution for the field level
- exact timing and adapted to synchronisation

Performance

- 256 digital I/Os in 12 μ s
- 1,000 digital I/Os in 30 μ s
- 200 analog I/Os (16 bit) in 50 μ s, corresponding to 20 kHz sampling rate
- 100 servo axes every 100 μ s
- 12,000 digital I/Os in 350 μ s

Topology

- line, tree or star topology
- up to 65,535 devices within one network
- network size: almost unlimited (> 500 km)
- operation with or without switches
- cost-effective cabling: Industrial Ethernet patch cable (CAT 5)
- twisted pair physical layer:
 - Ethernet 100BASE-TX, up to 100 m between 2 devices
 - or: fibre-optic cable variants, up to 20 km between 2 slaves
- hot connect/disconnect of bus segments

Address space

- network-wide process image: 4 Gbyte
- device process image: 1 bit to 64 kbyte
- address allocation: freely configurable
- device address selection: automatically via software

Cost benefits

- no more network tuning: lower engineering costs
- hard real-time with software master: no plug-in cards required
- no active infrastructure components (switches, etc.) required
- Ethernet cable and connector costs lower than for traditional fieldbuses
- EtherCAT right down to the I/O terminal:
 - no complex Bus Couplers required
- low interface costs due to highly integrated EtherCAT Slave Controller

Protocol

- optimised protocol directly within the Ethernet frame
- fully hardware-implemented
- for routing and socket interface: UDP datagram
- processing while passing
- distributed clocks for accurate synchronisation
- time stamp data types for resolution in the nanosecond range
- oversampling data types for high-resolution measurements

Diagnostics

- breaking point detection
- continuous “quality of line” measurement enables accurate localisation of transmission faults
- Topology View

Interfaces

- switch port terminal for standard Ethernet devices
- fieldbus terminals for fieldbus devices
- decentralised serial interfaces
- communication gateways
- gateway to other EtherCAT systems

Openness

- fully Ethernet-compatible
- operation with switches and routers possible
- mixed operation with other protocols also possible
- internet technologies (Web server, FTP, etc.)
- compatible with the existing Bus Terminal range
- protocol is published completely
- EtherCAT is IEC, ISO and SEMI standard.

EtherCAT Technology Group

- international pool of companies
- includes users and manufactures
- supports technology development
- ensures interoperability
- integration and development of device profiles

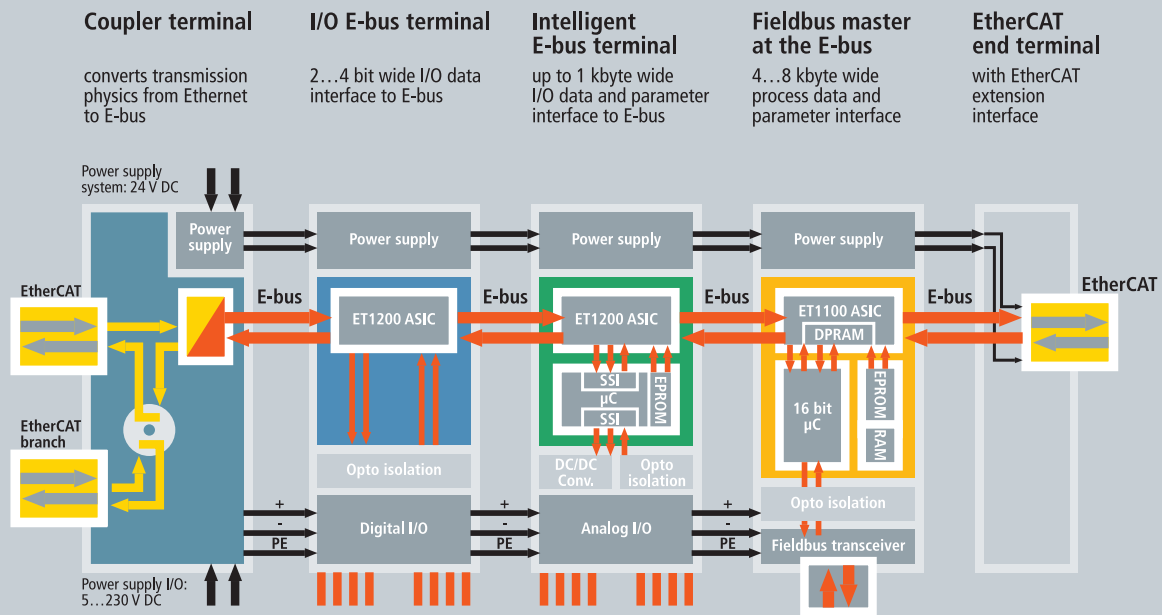

Protocol processing completely in hardware | Protocol ASICs flexibly configurable. Process interface from 1 bit to 64 kbyte.

Ethernet for Control Automation Technology

Real-time Ethernet: Ultra high-speed right up to the terminal

Outstanding performance, flexible topology and simple configuration characterise EtherCAT (Ethernet for Control Automation Technology), the real-time Ethernet technology from Beckhoff. EtherCAT sets new standards where conventional fieldbus systems reach their limits: 1,000 distributed I/Os in 30 µs, almost unlimited network size, and optimum vertical integration thanks to Ethernet and Internet technologies. With EtherCAT, the costly Ethernet star topology can be replaced with a simple line or tree structure – no expensive infrastructure components are required. All types of Ethernet devices can be integrated via a switch port.

Where other real-time Ethernet approaches require special master hardware or scanner cards, EtherCAT manages with very cost-effective standard Ethernet interface cards in the master.

Principle of operation

There are many different approaches that try to provide real-time capability for Ethernet: for example, the CSMA/CD access procedure is disabled via higher level protocol layers and replaced by time slicing or polling. Other propositions use special switches that distribute Ethernet telegrams in a precisely controlled timely manner. While these solutions are able to transport data packets more or less quickly and accurately to the

connected Ethernet node, bandwidth utilisation is very poor, particularly for typical automation devices, since even for very small data quantities a complete Ethernet frame has to be sent. Moreover, the times required for the redirection to the outputs or drive controllers and for reading the input data strongly depend on the implementation. A sub-bus is usually also required, particularly in modular I/O systems, which, like the Beckhoff K-bus, may be synchronised and fast, but nevertheless always adds small delays to the communication that cannot be avoided.

With EtherCAT technology, Beckhoff overcomes these system limitations of other Ethernet solutions: the process no longer involves consecutive steps for receiving and interpreting telegrams and copying the process data. In each device (down to the I/O terminals) the EtherCAT Slave Controller reads the data relevant for the device while the frame passes through it. Similarly, input data is inserted into the data stream on the fly. While the frames (delayed by only a few bit times) are already passed on, the slave recognises relevant commands and executes them accordingly. The process is hardware-implemented in the slave controller and is, therefore, independent of the protocol stack software run-times or the processor power. The last EtherCAT slave in the segment returns the fully processed frame, so that the first slave device forwards it to the master as a kind of response telegram.

From an Ethernet point of view, an EtherCAT bus segment is simply a single large Ethernet device that receives and sends Ethernet frames. However, the “device” does not contain a single Ethernet controller with downstream microprocessor, but a large number of EtherCAT slaves. Like for any other Ethernet device, direct communication may be established without a switch, thereby creating a pure EtherCAT system.

Ethernet down to the terminal

The Ethernet protocol remains intact right down to the individual devices, i.e. down to the individual I/O terminals; no sub-bus is required. Only the physical layer is converted in the coupler from 100BASE-TX or -FX to E-bus, in order to meet the requirements of the electronic terminal block. The E-bus signal type (LVDS) within the terminal block is nothing proprietary, it is also used for 10 Gbit Ethernet. At the end of the terminal block, the physical bus characteristics are converted back to the 100BASE-TX standard.

The on-board Ethernet MAC is sufficient as hardware in the master device. DMA (direct memory access) is used for data transfer to the main memory. That means that the network data access burden is lifted from the CPU. The same principle is also used in the Beckhoff multiport cards, which bundle up to four Ethernet channels on one PCI slot.

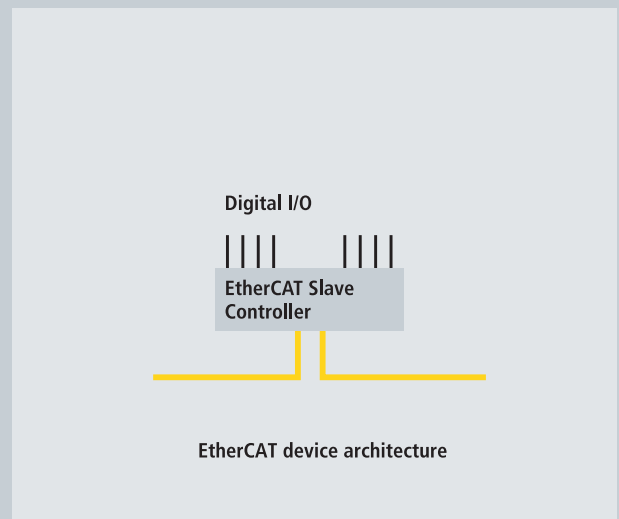
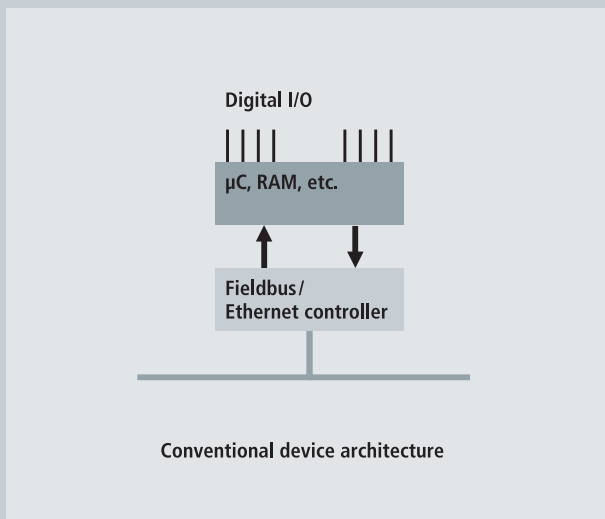

EtherCAT Slave Controller (ESC) | EtherCAT is not only faster outside the I/O device, but also inside. Digital I/Os are directly operated by the EtherCAT Slave Controller, without delays through local firmware and independent of the installed μC performance.

Protocol

The EtherCAT protocol is optimised for process data and is either transported directly in the Ethernet frame or packed into UDP/IP datagrams. The UDP version is used in situations where EtherCAT segments in other subnets are addressed via routers. Ethernet frames may contain several EtherCAT telegrams, with each telegram serving a particular memory area of the logical process image with an addressable size of up to 4 GB. The data sequence is independent of the physical order of the EtherCAT Terminals in the network; addressing can be in any order. Broadcast, Multicast and communication between slaves are possible.

The protocol can also handle parameter communication, which typically is acyclical. The structure and meaning of the parameters is specified via CANopen device profiles, which are available for a wide range of device classes and applications. EtherCAT also supports the servo profile according to IEC 61800-7-204. Under the name of SERCOS this profile is recognised and popular for Motion Control applications worldwide.

In addition to data exchange according to the master/slave principle, EtherCAT is also very suitable for communication between controllers (master/master). Freely addressable network variables for process data and a variety of services for parameterisation, diagnosis, programming and remote control cover a wide range of requirements.

The data interfaces for master/slave and master/master communication are identical.

Performance

EtherCAT reaches new dimensions in network performance. The update time for the data from 1,000 distributed inputs/outputs is only $30\ \mu\text{s}$ – including terminal cycle time. Up to 1,486 byte of process data can be exchanged with a single Ethernet frame – this is equivalent to almost 12,000 digital inputs and outputs. The transfer of this data quantity only takes $300\ \mu\text{s}$.

The communication with 100 servo axes takes place every $100\ \mu\text{s}$. With this cycle time, all axes are provided with set values and control data and report their actual position and status. The distributed clocks technique enables the axes to be synchronised with a jitter of significantly less than 1 microsecond.

The extremely high performance of the EtherCAT technology enables control concepts that could not be realised with classic fieldbus systems. Very fast control loops can thus also be closed via the bus. Functions that previously required dedicated local hardware support can now be mapped in software. The tremendous bandwidth enables status information to be transferred with each data item. With EtherCAT, a communication technology is available that matches the superior computing capacity of modern Industrial PCs. The bus system is no longer

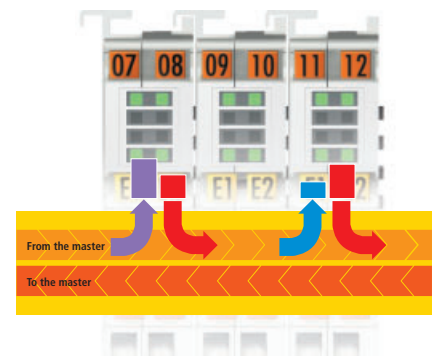

FMMU: telegram processing completely in hardware

the “bottleneck” of the control concept. Distributed I/Os are recorded faster than is possible with most local I/O interfaces.

The benefits of this network performance also become apparent in smaller controllers with comparatively moderate computing capacity. The EtherCAT cycle is so fast that it can be executed between two control cycles. The controller thus always has the latest input data available; the outputs are addressed with minimum delay. The response behaviour of the controller is improved significantly without increasing the computing capacity itself.

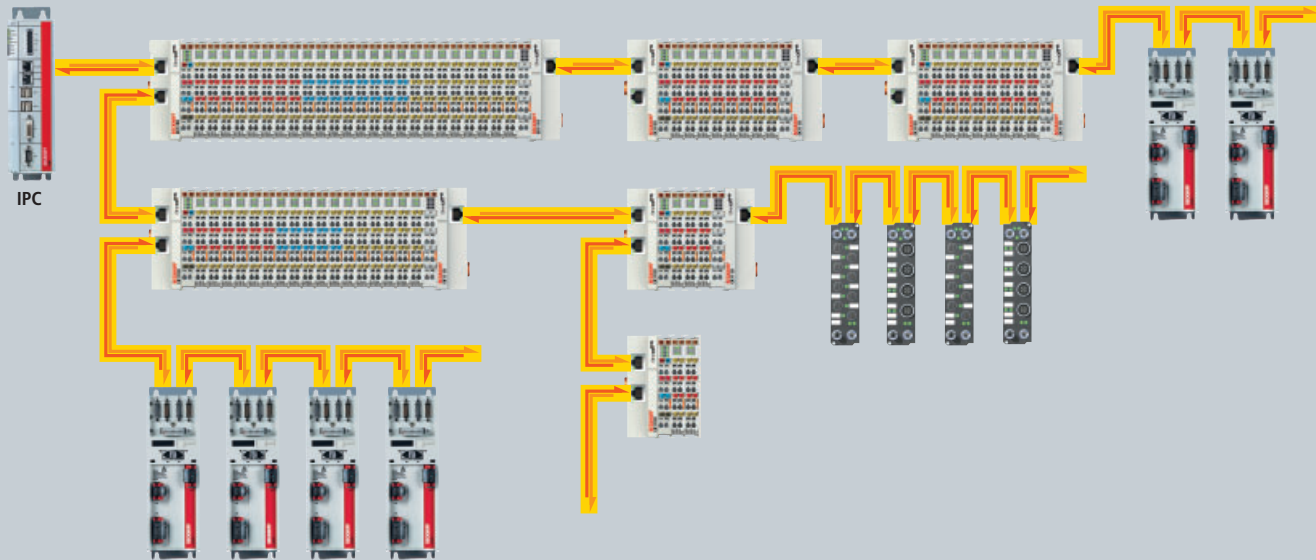

Freedom in the choice of topology | Maximum flexibility for wiring: with or without switch, line or tree topologies can be freely selected and combined. Address assignment is automatic; no IP address setting is required.

The EtherCAT technology principle is scalable and not bound to the baud rate of 100 Mbaud – extension to Gbit Ethernet is possible.

EtherCAT instead of PCI

With increasing miniaturisation of the PC components, the physical size of Industrial PCs is increasingly determined by the number of required slots. The bandwidth of Fast Ethernet, together with the data width of the EtherCAT communication hardware (EtherCAT Slave Controller) opens up new opportunities: interfaces that are conventionally located in the IPC are transferred to intelligent interface terminals at the EtherCAT system. Apart from the decentralised I/Os, axes and control units, complex systems such as fieldbus masters, fast serial interfaces, gateways and other communication interfaces can be addressed via a single Ethernet port in the PC. Even further Ethernet devices without restriction on protocol variants can be connected via decentralised switch port terminals. The central IPC becomes smaller and therefore more cost-effective, one Ethernet interface is sufficient for the complete communication with the periphery.

Topology

Line, tree or star: EtherCAT supports almost any topology. The bus or line structure known from the fieldbuses thus also becomes avail-

able for Ethernet. Particularly useful for system wiring is the combination of lines and branches or stubs. The required interfaces exist on the couplers; no additional switches are required. Naturally, the classic Ethernet star topology with junction terminals can also be used.

Wiring flexibility is further maximised through the choice of different cables. Flexible and inexpensive screened Industrial Ethernet fieldbus cables transfer the signals in Ethernet mode (100BASE-TX) up to a cable length of 100 m between two devices. The complete bandwidth of the Ethernet network – such as different optical fibres and copper cables – can be used in combination with switches or media converters. For each cable distance, the signal variant can be selected individually. Since up to 65,535 devices can be connected, the size of the network is almost unlimited.

Distributed clocks

Accurate synchronisation is particularly important in cases where spatially distributed processes require simultaneous actions. This may be the case, for example, in applications where several servo axes carry out coordinated movements simultaneously.

The most powerful approach for synchronisation is the accurate alignment of distributed clocks. In contrast to fully synchronous communication, where synchronisation quality suffers immediately in the event of a com-

munication fault, distributed aligned clocks have a high degree of tolerance vis-à-vis possible fault-related delays within the communication system. With EtherCAT, the data exchange is fully based on a pure hardware machine. Since the communication utilises a logical (and thanks to full-duplex Fast Ethernet, also physical) ring structure, the “master clock” can determine the run-time offset to the individual “slave clocks” simply and accurately – and vice versa. The distributed clocks are adjusted based on this value, which means that a very precise network-wide timebase with a jitter of significantly less than 1 microsecond is available.

However, high-resolution distributed clocks are not only used for synchronisation, but can also provide accurate information about the local timing of the data acquisition. Thanks to new, extended data types, very precise time stamps can be assigned to measured values.

Hot Connect

Many applications require a change in I/O configuration during operation. Examples are machining centres with changing, sensor-equipped tool systems or transfer systems with intelligent, flexible workpiece carriers, or printing machines in which individual printing units are switched off. The protocol structure of the EtherCAT system takes account of these requirements: the Hot Connect function enables parts of the network to be linked and

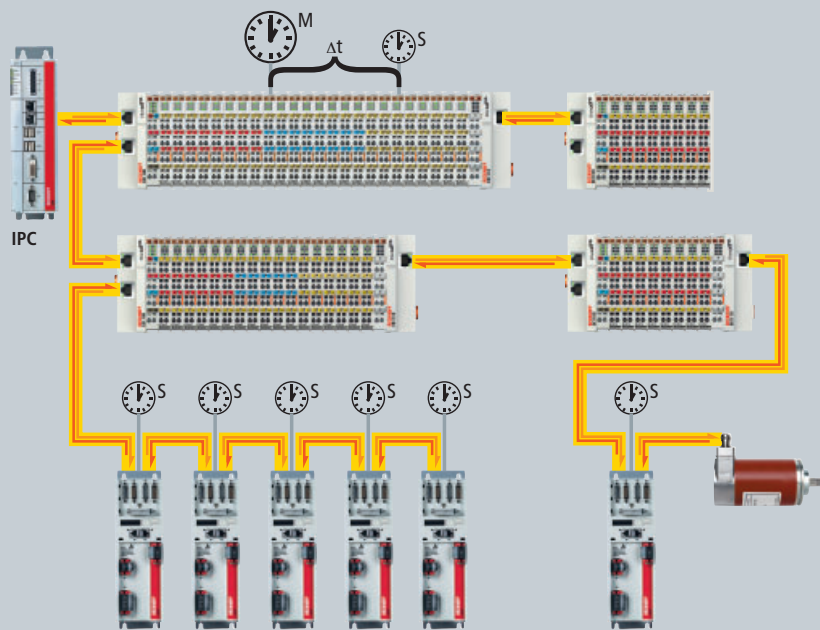

Distributed clocks | Local absolute system synchronisation for CPU, I/O and drive units

decoupled or reconfigured “on the fly”, offering flexible response capability for changing configurations.

High availability

Increasing demands in terms of system availability are catered for with optional cable redundancy that enables devices to be changed without having to shut down the network. EtherCAT also supports redundant masters with hot standby functionality. Since the EtherCAT Slave Controllers immediately return the frame automatically if an interruption is encountered, failure of a device does not lead to the complete network being shut down. Dragchain applications, for example, can thus be specifically configured as stubs in order to be prepared for cable break.

Safety over EtherCAT

In the interest of achieving safe data communication with EtherCAT, the Safety over EtherCAT protocol has been created. The protocol meets the requirements of IEC 61508 up to Safety Integrity Level (SIL) 3 and IEC 61784-3, as approved by the German Technical Inspection Agency (TÜV).

EtherCAT is used as a single-channel communication system. The transport medium is regarded as a “black channel” and is not included in the safety considerations. Thus, the protocol can also be transmitted by other communication systems, backplanes, WLAN, etc. The transfer cycle can be as short

as required without affecting residual error probability. The cyclic exchange of safe data between a Safety over EtherCAT master and a Safety over EtherCAT slave is referred to as a connection that is monitored via a watchdog timer. A master can establish and monitor several connections to different slaves.

Diagnostics

The diagnostic capability of a network is a crucial factor for availability and commissioning times – and therefore overall costs. Only faults that are detected quickly and accurately and located unambiguously can be rectified quickly. Therefore, special attention was paid to exemplary diagnostic features during the development of EtherCAT.

During commissioning, the actual configuration of the I/O terminals should be checked for consistency with the specified configuration. The topology should also match the configuration. Due to the built-in topology recognition down to the individual terminals, the verification can not only take place during system start-up, automatic reading in of the network is also possible (configuration upload).

Bit faults during the transfer are reliably detected through evaluation of the CRC checksum in each device. Apart from breaking point detection and localisation, the protocol, transfer physics and topology of the EtherCAT system enable individual

quality monitoring of each individual transmission segment. The automatic evaluation of the associated error counters enables precise localisation of critical network sections. Gradual or changing sources of error such as EMC influences, defective connectors or cable damage are detected and located.

EtherCAT components

On the hardware side, EtherCAT technology is located in EtherCAT Terminals, for example. The I/O system in protection class IP 20 is based on the housing of the tried and tested Beckhoff Bus Terminal system. In contrast to Bus Terminals, where the fieldbus protocol data is converted within the Bus Coupler to the internal, fieldbus-independent terminal bus, the EtherCAT protocol remains fully intact down to the individual terminal. In addition to EtherCAT Terminals with E-bus connection, the proven standard Bus Terminals with K-bus connection can also be connected via the BK1120 EtherCAT Bus Coupler. This ensures compatibility and continuity with the prevalent system. Existing and future investments are protected.

EtherCAT is integrated in further Beckhoff components, such as the Fieldbus Box in protection class IP 67. The extension modules can be connected directly via an IL230x-B110 EtherCAT Coupler Box. The EtherCAT Box modules, also in protection class IP 67, feature an integrated EtherCAT interface and can be connected directly to

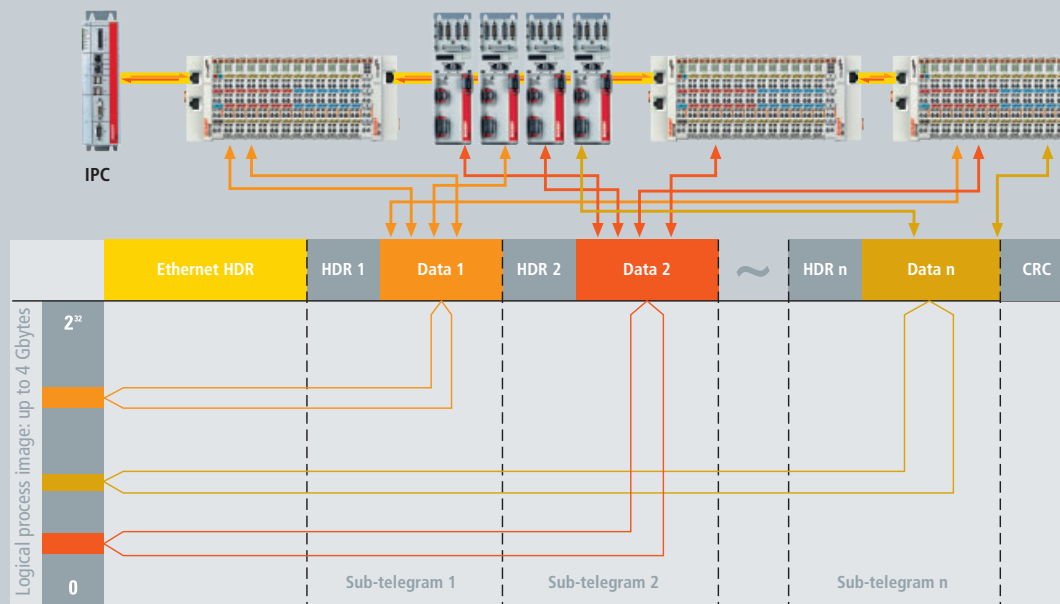

Protocol structure | The process image allocation is freely configurable. Data are copied directly in the I/O terminal to the desired location within the process image: no additional mapping is required. There is a very large address space of 4 Gbytes.

an EtherCAT network without an additional Coupler Box.

The Beckhoff Industrial PCs, the Embedded PCs of the CX series, the Control Panels with control functionality, and the Ethernet PCI cards already offer inherent EtherCAT capability. The Beckhoff Servo Drives are also available with EtherCAT interface.

Openness

The EtherCAT technology is not only fully Ethernet-compatible, but also characterised by particular openness “by design”: the protocol tolerates other Ethernet-based services and protocols on the same physical network – usually only with minimum loss of performance. Any Ethernet device can be connected within the EtherCAT segment via a switch port terminal without influencing the cycle time. Devices with fieldbus interface are integrated via EtherCAT fieldbus master terminals. The UDP protocol variant can be implemented on each socket interface. EtherCAT is a fully open protocol. It is recognised and available as an official IEC specification (IEC 61158, type 12).

that the EtherCAT technology functions and interfaces are ideally prepared for the widest range of applications. The organisation ensures that EtherCAT can be easily and cost-effectively integrated in all kinds of automation devices, while ensuring interoperability of these implementations. The EtherCAT Technology Group is the official IEC partner organisation for fieldbus standardisation. Membership is open to all companies.

For further information see www.ethercat.org



EtherCAT Technology Group

The EtherCAT Technology Group (ETG) is an association of automation users and manufacturers with a mission to support the development of EtherCAT technology. The group represents a variety of industry sectors and application areas. This ensures

EtherCAT system overview

Flexible topology

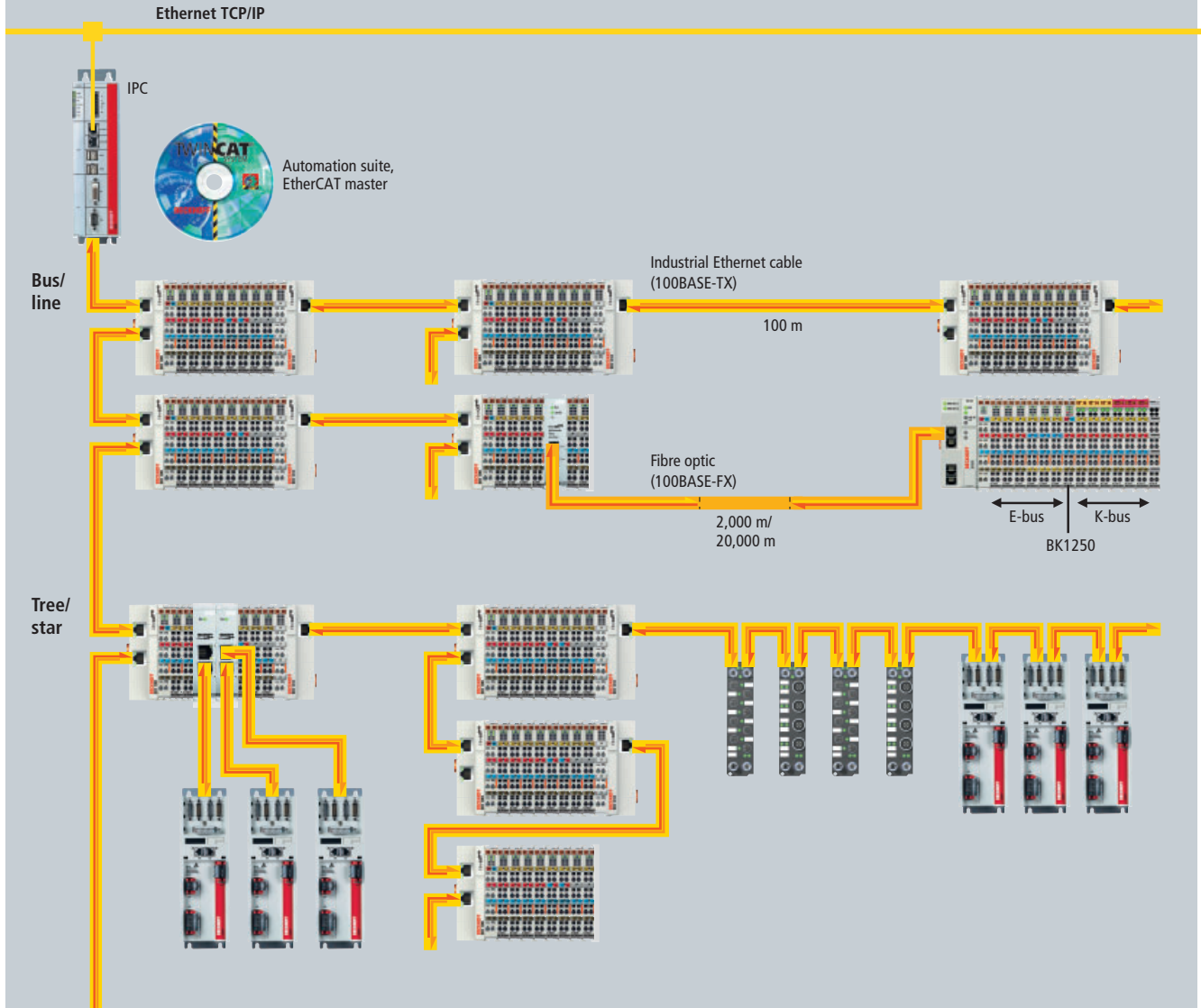

Fieldbus integration

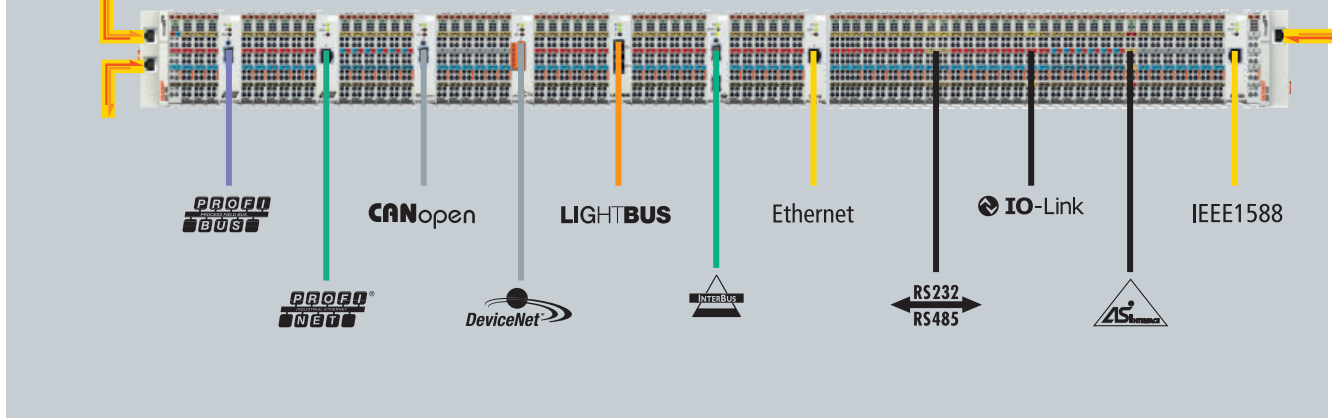

EtherCAT bridge

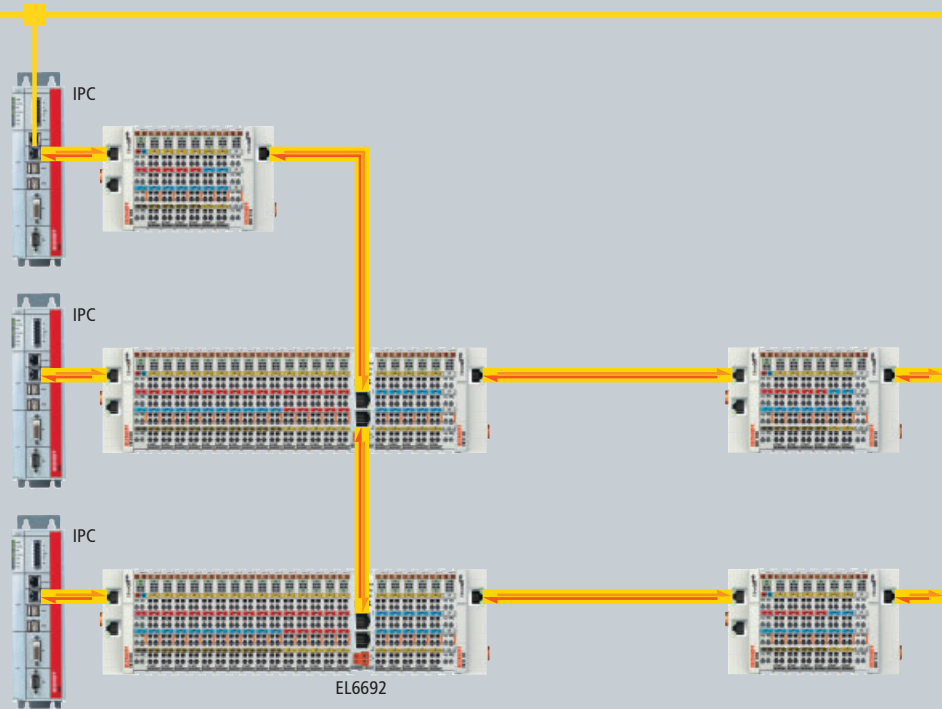

Cable redundancy

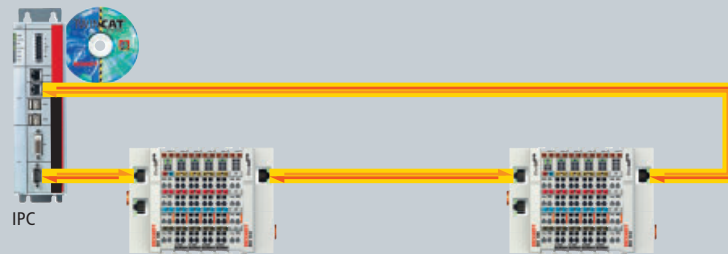

Safety

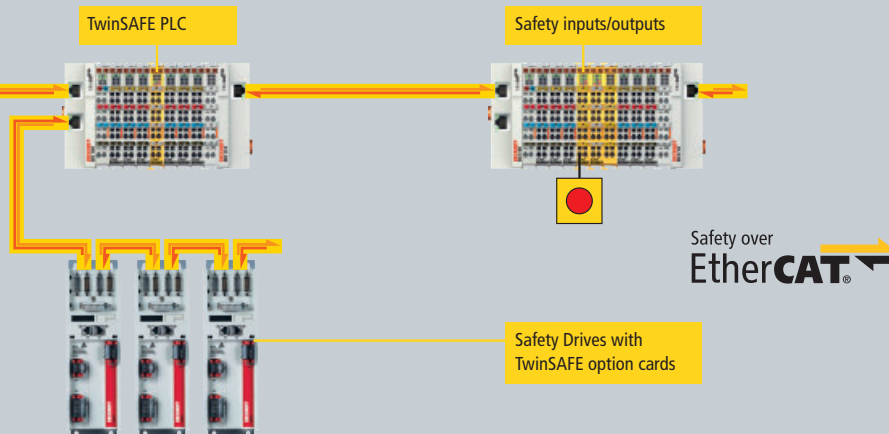

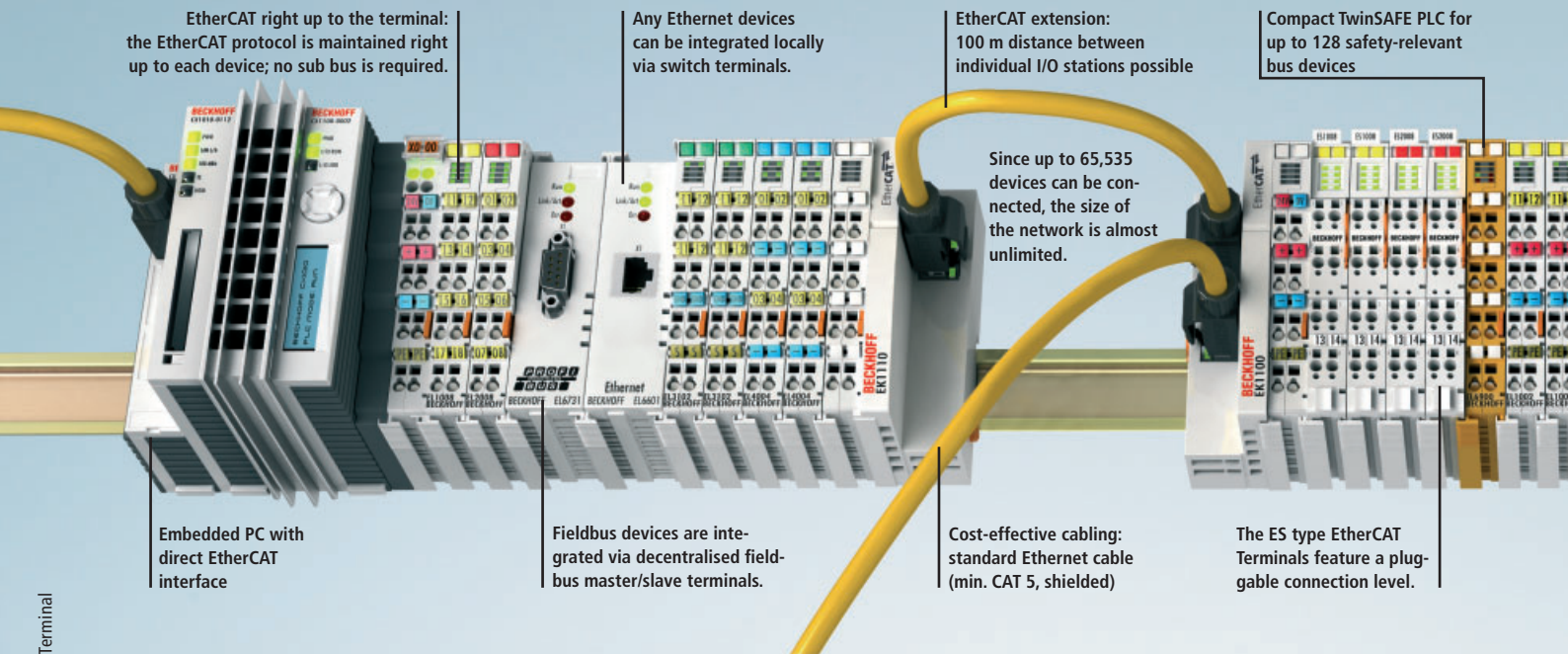

EtherCAT right up to the terminal: the EtherCAT protocol is maintained right up to each device; no sub bus is required.

Any Ethernet devices can be integrated locally via switch terminals.

EtherCAT extension: 100 m distance between individual I/O stations possible

Compact TwinSAFE PLC for up to 128 safety-relevant bus devices

Since up to 65,535 devices can be connected, the size of the network is almost unlimited.

Embedded PC with direct EtherCAT interface

Fieldbus devices are integrated via decentralised fieldbus master/slave terminals.

Cost-effective cabling: standard Ethernet cable (min. CAT 5, shielded)

The ES type EtherCAT Terminals feature a plug-gable connection level.

Beckhoff EtherCAT Terminals

In analogy to the Beckhoff Bus Terminals, the EtherCAT Terminal system is a modular I/O system consisting of electronic terminal blocks. In contrast to Bus Terminals, where the fieldbus signal is implemented within the Bus Coupler on the internal, fieldbus-independent terminal bus, the EtherCAT protocol remains fully intact down to the individual terminal. In addition to EtherCAT Terminals with E-bus connection, the proven standard Bus Terminals with K-bus connection can also be connected via the BK1120 EtherCAT Bus Coupler. This ensures compatibility and continuity with the existing system. Existing and future investments are protected.

Structure

The robust housing, secure contacts and the solidly built electronics are prominent features of Beckhoff components. An I/O station consists of an EtherCAT Coupler and almost any number of terminals. Since up to 65,535 devices can be connected, the size of the network is almost unlimited.

The electronic terminal blocks are attached to the EtherCAT Coupler. The contacts are made as the terminal clicks into place, without any other manipulation. This means that each electronic terminal block can be individually exchanged. It can be placed on a standard DIN rail.

Like the Beckhoff Bus Terminals, the outer contour of the EtherCAT Terminals perfectly adapts to the dimensions of terminal boxes. A clearly arranged connection panel with LEDs for status display and push-in contact labels ensures clarity in the field. 3-wire conductors with an additional connection for a protective conductor, enable direct connection of sensors and actuators.

Free mix of signals

Suitable EtherCAT Terminals are available for all common digital and analog signal types encountered in the world of automa-

tion. Fieldbus devices, e.g. for PROFIBUS, PROFINET, CANopen, DeviceNet, Interbus, IO-Link or Lightbus, are integrated via local fieldbus master/slave terminals. Removal of the fieldbus master saves PCI slots in the PC. Any Ethernet devices can be integrated locally via switch port terminals.

The fine granularity of the EtherCAT Terminals enables bit-precise composition of the required I/O channels. The digital EtherCAT Terminals are designed as 2-, 4-, 8- or 16-channel terminals. In the 16-channel variant, digital input and output signals are arranged in an ultra-compact way within

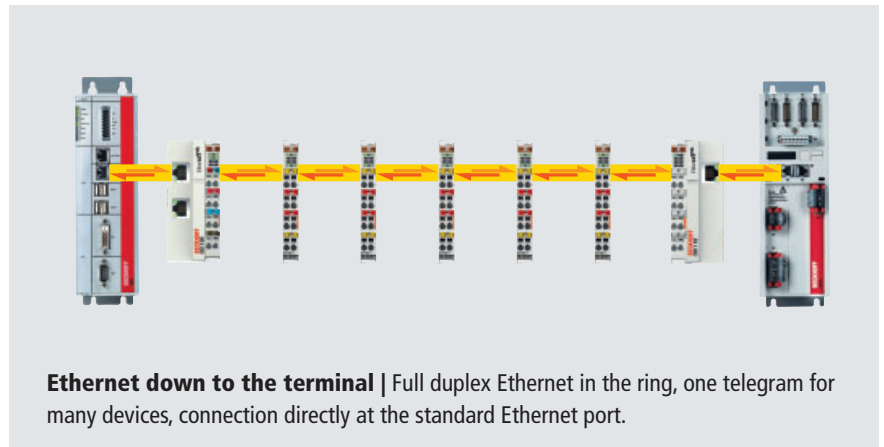

Ethernet down to the terminal | Full duplex Ethernet in the ring, one telegram for many devices, connection directly at the standard Ethernet port.

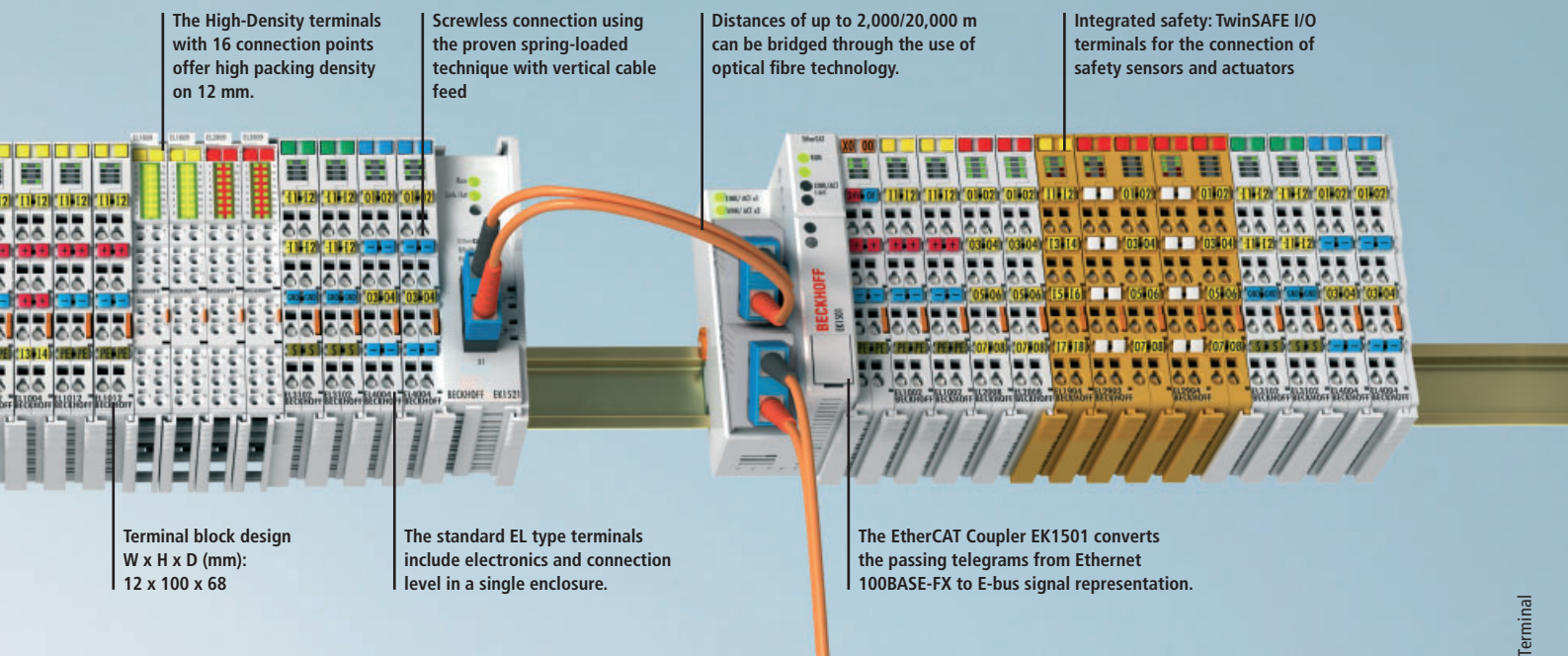

The High-Density terminals with 16 connection points offer high packing density on 12 mm.

Screwless connection using the proven spring-loaded technique with vertical cable feed

Distances of up to 2,000/20,000 m can be bridged through the use of optical fibre technology.

Integrated safety: TwinSAFE I/O terminals for the connection of safety sensors and actuators

Terminal block design
W x H x D (mm):
12 x 100 x 68

The standard EL type terminals include electronics and connection level in a single enclosure.

The EtherCAT Coupler EK1501 converts the passing telegrams from Ethernet 100BASE-FX to E-bus signal representation.

a standard terminal housing across a width of only 12 mm. The standard analog signals of -10...+10 V, 0...10 V, 0...20 mA and 4...20 mA are all available as 1-, 2-, 4- and 8-channel variants within a standard housing.

Flexible connection system

The EtherCAT Terminal system offers different connection options for optimum adaptation to the respective application. The ELxxxx EtherCAT Terminals include electronics and connection level in a single enclosure. The ESxxxx type EtherCAT Terminals feature a pluggable connection level.

The ES series Bus Terminals enable the complete wiring to be removed as a plug connector from the top of the housing for servicing.

Bus Coupler for the EtherCAT Terminal system

The Bus Couplers from the EKxxxx series connect conventional fieldbus systems to EtherCAT. The ultra-fast, powerful I/O system with its large choice of terminals is now available for other fieldbus and Industrial Ethernet systems. EtherCAT makes a very flexible topology configuration possible. Thanks to the Ethernet physics, long dis-

tances can also be bridged without the bus speed being affected. When changing to the field level – without a control cabinet – the IP 67 EtherCAT Box modules (EPxxxx) can also be connected to the EKxxxx. The EKxxxx Bus Couplers are fieldbus slaves and contain an EtherCAT master for the EtherCAT Terminals. The EKxxxx is integrated in exactly the same way as the Bus Couplers from the BKxxxx series via the corresponding fieldbus system configuration tools and the associated configuration files, such as GSD, ESD or GSDML. The TwinCAT-programmable variant is the CX8000 Embedded PC series.

EtherCAT Terminal features

EtherCAT down to the terminal: the EtherCAT protocol is maintained down to each device; no sub bus is required.

Status LEDs for secure commissioning

Terminal block design
W x H x D (mm):
12 x 100 x 68

EtherCAT Terminals

Embedded PC with direct E-bus interface

Protection of investment: fieldbus devices are integrated via decentralised fieldbus master/slave terminals.

Any Ethernet device can be integrated locally via switch port terminals.

Compatibility and integration: in addition to EtherCAT Terminals, the tried and tested Bus Terminals can also be connected via the BK1120 EtherCAT Bus Coupler.



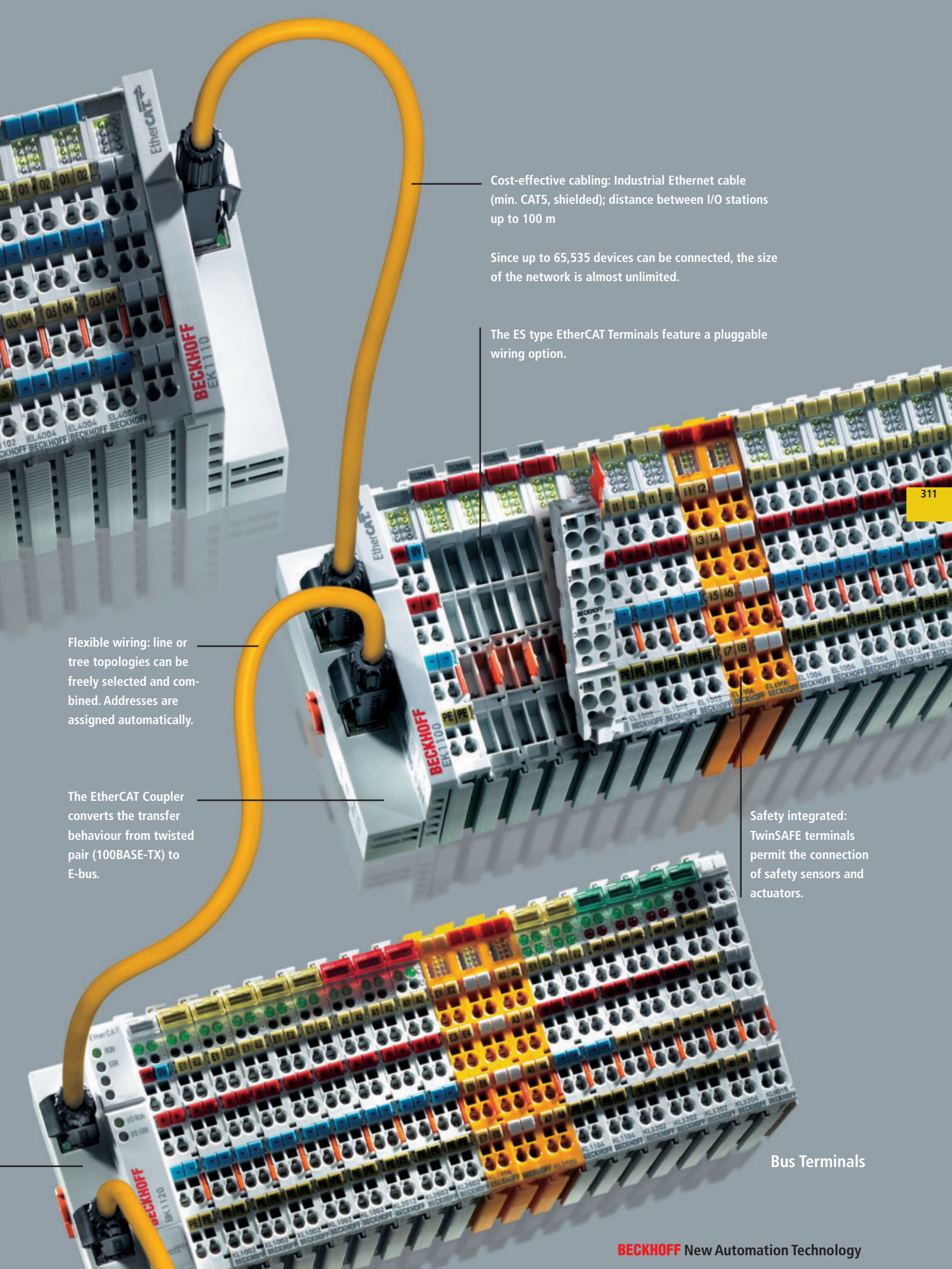

Cost-effective cabling: Industrial Ethernet cable (min. CAT5, shielded); distance between I/O stations up to 100 m

Since up to 65,535 devices can be connected, the size of the network is almost unlimited.

The ES type EtherCAT Terminals feature a pluggable wiring option.

Flexible wiring: line or tree topologies can be freely selected and combined. Addresses are assigned automatically.

The EtherCAT Coupler converts the transfer behaviour from twisted pair (100BASE-TX) to E-bus.

Safety integrated: TwinSAFE terminals permit the connection of safety sensors and actuators.

311

Bus Terminals

Beckhoff EtherCAT Terminals



EK EtherCAT Coupler series



Bus Coupler, e.g. PROFIBUS, PROFINET



CX8000 Embedded PC series with integrated fieldbus slave

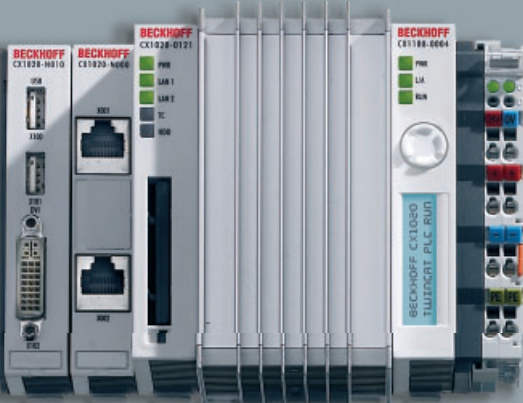

Embedded PC series CX for PLC and Motion Control applications

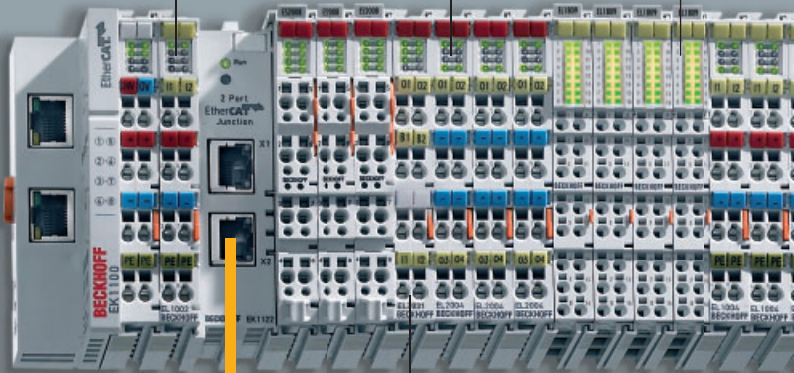

Free mix of signals: more than 200 different EtherCAT Terminals enable connection of all common sensors and actuators.

EtherCAT Terminals in 1-, 2-, 4-, 8- and 16-channel modularity

The EtherCAT Terminals with 16 connection points offer high packing density on 12 mm.

EtherCAT motion terminals for stepper motors, DC motors or hydraulic valves

Optional fieldbus integration via decentralised fieldbus master/slave terminals

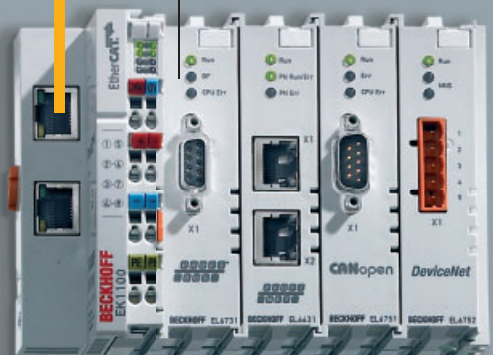

Compact Safety PLC for TwinSAFE for up to 128 safety-relevant bus devices

Ultra-fast I/O terminals for I/O response times $< 100 \mu\text{s}$ for fast I/O, oversampling and time stamp

Power over EtherCAT junction

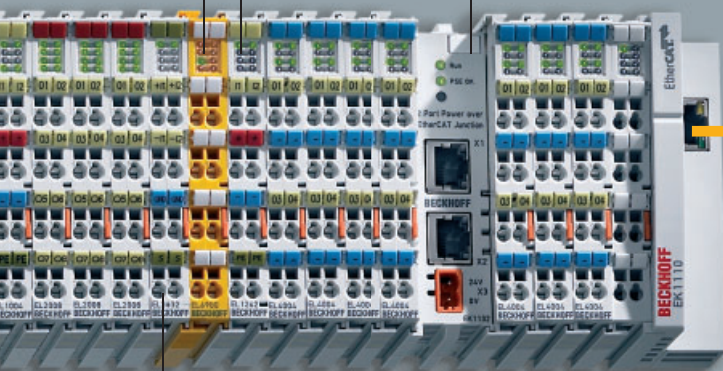

Advanced measurement technology based on EtherCAT and XFC: high-speed measurement, high-precision measurement, Condition Monitoring, energy monitoring, closed loop control

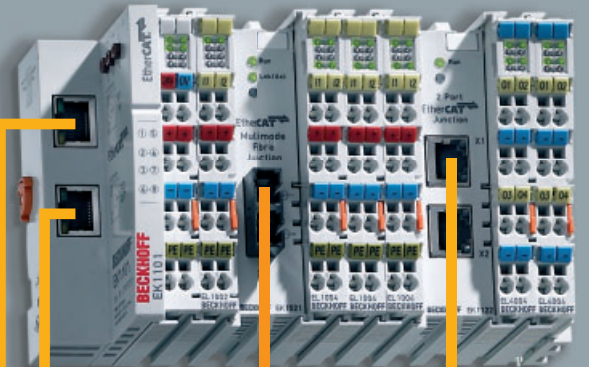

2,000/20,000 m fibre optic (100BASE-FX)

100 m Industrial Ethernet cable (100BASE-TX)



IP 67 EtherCAT Box

