



User Guide

Commander SE

Sizes 1 to 5



Variable speed drive for 3 phase induction motors
from 0.25kW to 37kW

Part Number: 0452-0061

Issue Number: 8

General Information

The manufacturer accepts no liability for any consequences resulting from inappropriate, negligent or incorrect installation or adjustment of the optional operating parameters of the equipment or from mismatching the variable speed drive (Drive) with the motor.

The contents of this User Guide are believed to be correct at the time of printing. In the interests of a commitment to a policy of continuous development and improvement, the manufacturer reserves the right to change the specification of the product or its performance, or the contents of the User Guide, without notice.

All rights reserved. No parts of this User Guide may be reproduced or transmitted in any form or by any means, electrical or mechanical including photocopying, recording or by an information storage or retrieval system, without permission in writing from the publisher.

Drive software version

This product is supplied with the latest version of user-interface and machine control software. If this product is to be used in a new or existing system with other Commander SE Drives, there may be some differences between their software and the software in this product. These differences may cause this product to function differently. This may also apply to Drives returned from a Control Techniques Service Centre.

If there is any doubt, contact a Control Techniques Drive Centre.

Copyright © December 2001 Control Techniques Drives Limited

Issue Code: 8

Software: V02.00.00 onwards

Contents

1	Safety Information	1
1.1	Warnings, Cautions and notes	1
1.2	Electrical safety - general warning	1
1.3	System design and safety of personnel	1
1.4	Environmental limits	2
1.5	Compliance with regulations	2
1.6	Motor	2
1.7	Adjusting parameters	2
2	Options	3
3	Technical Data	4
3.1	Power dependant rating data	4
3.2	General data	12
3.3	RFI Filters	14
4	Installing the drive	16
4.1	Safety information	16
4.2	Planning the installation	16
4.3	Mechanical installation	17
4.4	Electrical installation	23
4.5	Electromagnetic compatibility (EMC)	27
5	Terminals	34
5.1	Power terminal connections	34
5.2	Control terminal connections	35
5.3	Serial communication connections	36
5.4	Control terminal specifications	37
6	Handling and Programming	40
6.1	Display and keypad	40
6.2	Display Messages	41
6.3	Selecting and changing parameters	41
6.4	Saving parameters	42
6.5	Security codes	42
6.6	Setting a security code	42
6.7	Unlocking a security code	43
6.8	Set security back to zero (0) - no security	43
6.9	Setting to default values	43
6.10	Level 1 and level 2 parameter descriptions	43
7	Getting Started - Bench Testing	61
7.1	Terminal control	61
7.2	Keypad control	63
8	Diagnostics and Protective Features	65
8.1	Trip codes	65
8.2	Alarm warnings	67
8.3	HF-Hardware fault trip codes	67

9	Parameter List	68
10	Advanced Functions	69
10.1	Speed control	69
10.2	Ramps	69
10.3	Torque control	69
10.4	Stopping	69
10.5	Programmable I/O	69
10.6	Motor protection	69
10.7	Monitoring	69
10.8	Auxiliary functions	69
10.9	Second motor selection	69
11	UL Listing Information	70
11.1	Common UL information	70
11.2	Power dependant UL information	70

Declaration of Conformity

Control Techniques, The Gro, Newtown, Powys, UK. SY16 3BE

SE11200025	SE11200037	SE11200055	SE11200075		
SE2D200075	SE2D200110	SE2D200150	SE2D200220		SE23200400
SE23400075	SE23400110	SE23400150	SE23400220	SE23400300	SE23400400
SE33200550	SE33400550	SE33200750	SE33400750	SE43401100	SE43401500
SE43401850	SE53402200	SE53403000	SE53403700		

The AC variable speed drive products listed above, have been designed and manufactured in accordance with the following European harmonised, national and international standards:

EN60249	Base materials for printed circuits
IEC60326-1	Printed boards: general information for the specification writer
IEC60326-5	Printed boards: specification for single- and double-sided printed boards with plated-through holes
IEC60326-6	Printed boards: specification for multilayer printed boards
IEC60664-1	Insulation co-ordination for equipment within low-voltage systems: principles, requirements and tests
EN60529	Degrees of protection provided by enclosures (IP code)
UL94	Flammability rating of plastic materials
UL508C	Standard for power conversion equipment
*EN50081-1	Generic emission standard for the residential, commercial and light industrial environment
EN50081-2	Generic emission standard for the industrial environment
EN50082-2	Generic immunity standard for the industrial environment
EN61800-3	Adjustable speed electrical power drive systems - Part 3: EMC product standard including specific test methods
**EN61000-3-2	Electromagnetic compatibility (EMC). Limits. Limits for harmonic current emissions (equipment input current <16A per phase)
***EN61000-3-3	Electromagnetic compatibility (EMC). Limits. Limitation of voltage fluctuations and flicker in low-voltage supply systems for equipment with rated current < 16A

*Applies to Size 1 units only.

**SE11200025, SE11200037, SE11200055: input choke required. All other units where input current <16A: for professional use only.

***Applies to the following models: SE11200025 - SE11200075, SE2D200075, SE2D200110, SE23400075 - SE23400220, SE23400300, SE23400400, SE33400550, SE33400750.

These products comply with the Low Voltage Directive 73/23/EEC, the Electromagnetic Compatibility (EMC) Directive 89/336/EEC and the CE Marking Directive 93/68/EEC.



W. Drury

Executive VP Technology

Date: 1 November 2001

These electronic Drive products are intended to be used with appropriate motors, controllers, electrical protection components and other equipment to form complete end products or systems. Compliance with safety and EMC regulations depends upon installing and configuring Drives correctly, including using the specified input filters. The Drives must be installed only by professional assemblers who are familiar with requirements for safety and EMC. The assembler is responsible for ensuring that the end product or system complies with all the relevant laws in the country where it is to be used. Refer to this User Guide. A Commander SE EMC Data Sheet is also available giving detailed EMC information.

1 Safety Information

1.1 Warnings, Cautions and notes



A **Warning** contains information which is essential for avoiding a safety hazard.



A **Caution** contains information which is necessary for avoiding a risk of damage to the product or other equipment.

NOTE

A **Note** contains information which helps to ensure correct operation of the product.

1.2 Electrical safety - general warning

The voltages used in the drive can cause severe electrical shock and/or burns, and could be lethal. Extreme care is necessary at all times when working with or adjacent to the drive.

Specific warnings are given at the relevant places in this User Guide.

1.3 System design and safety of personnel

The drive is intended as a component for professional incorporation into complete equipment or a system. If installed incorrectly, the drive may present a safety hazard. The drive uses high voltage and currents, carries a high level of stored electrical energy, and is used to control equipment which can cause injury.

Close attention is required to the electrical installation and the system design to avoid hazards, either in normal operation or in the event of equipment malfunction. System design, installation, commissioning and maintenance must be carried out by personnel who have the necessary training and experience. They must read this safety information and this User Guide carefully.

The STOP function of the drive does not remove dangerous voltages from the output of the drive or from any external option unit.

Careful consideration must be given to the functions of the drive which might result in a hazard, either through their intended functions or through incorrect operation due to a fault.

In any application where a malfunction of the drive could lead to damage, loss or injury, a risk analysis must be carried out, and where necessary, further measures taken to reduce the risk.

The STOP and START controls or electrical inputs of the drive must not be relied upon to ensure safety of personnel. If a safety hazard could exist from unexpected starting of the drive, an interlock that electrically isolates the drive from the AC supply must be installed to prevent the motor being inadvertently started.

To ensure mechanical safety, additional safety devices such as electro-mechanical interlocks and overspeed protection devices may be required. The drive must not be used in a safety critical application without additional high integrity protection against hazards arising from a malfunction.

Under certain conditions, the drive can suddenly discontinue control of the motor. If the load on the motor could cause the motor speed to be increased (e.g. in hoists and cranes), a separate method of braking and stopping must be used (e.g. a mechanical brake).

1.4 Environmental limits

Instructions in this User Guide regarding transport, storage, installation and use of the drive must be complied with, including the specified environmental limits. Drives must not be subjected to excessive physical force.

1.5 Compliance with regulations

The installer is responsible for complying with all relevant regulations, such as national wiring regulations, accident prevention regulations and electromagnetic compatibility (EMC) regulations. Particular attention must be given to the cross-sectional areas of conductors, the selection of fuses or other protection, and protective earth (ground) connections.

This User Guide contains instruction for achieving compliance with specific EMC standards.

Within the European Union, all machinery in which this product is used must comply with the following directives:

- 97/37/EC: Safety of machinery.
- 89/336/EEC: Electromagnetic Compatibility.

1.6 Motor

Ensure the motor is installed in accordance with the manufacturer's recommendations. Ensure the motor shaft is not exposed.

Standard squirrel cage induction motors are designed for single speed operation. If it is intended to use the capability of the drive to run a motor at speeds above its designed maximum, it is strongly recommended that the manufacturer is consulted first.

Low speeds may cause the motor to overheat because the cooling fan becomes less effective. The motor should be fitted with a protection thermistor. If necessary, an electric forced vent fan should be used.

1.7 Adjusting parameters

Some parameters have a profound effect on the operation of the drive. They must not be altered without careful consideration of the impact on the controlled system. Measures must be taken to prevent unwanted changes due to error or tampering.

2 Options

The following options are available for Commander SE;

- *Quickey* for rapid parameter transfer (SE55)
- Standard and low earth leakage footprint / side mounting RFI filters and low cost panel mounting RFI filters
- Universal Keypad, IP65, hand held or door mounting plain text, LCD display
- SE Soft Windows™ based set-up software for advanced programming
- +10V to -10V analog input card for bi-directional input reference (SE51)
- Cable screening bracket and screening clamps to provide a convenient way of connecting supply, motor and control cable screens to ground (SE11, 12, 13, 14 & 15) (SE15 for Size 5 control cables only)
- EMC Data Sheets
- Through hole mounting plate drawings to allow heatsink to be put outside main cubicle (Size 2 ~ 4 only)
- EIA232 to EIA485 (2 wire) converter for connecting between the drive and PC when using SE Soft (SE71 Communications lead)
- Fieldbus Communications:
 - Profibus DP (SE73)
 - Device Net (SE77)
 - CAN Open (SE77)
 - Interbus (SE74)
- *Commander SE Advanced User Guide*: (See Chapter 10 *Advanced Functions* on page 69 for a list of advanced functions).
- AC input line reactors
- Braking resistors and mounting plate (Size 2 ~ 4 only)

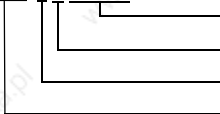
For further details on the above options and availability, contact your local Control Techniques Drive Centre or Distributor.

3 Technical Data

3.1 Power dependant rating data

Model code explanation

SE 1 1 2 xxxxx



Drive kilowatt rating: 00025 = 0.25kW etc.

Drive voltage rating: 2 = 230V, 4 = 400V

Number of input phases: 1 = 1Ø, 3 = 3Ø, D = 1Ø and 3Ø

Frame size.

MODEL	SE11200...			
	025	037	055	075
AC supply voltage and frequency	Single phase 200 - 240V +/- 10% 48 - 62Hz			
Input displacement factor (cos φ)	>0.97			
Nominal motor power - kW	0.25	0.37	0.55	0.75
Nominal motor power - hp		0.50		1.0
Output voltage and frequency	3 phase, 0 to input voltage, 0 to 1000Hz			
100% RMS output current - A	1.5	2.3	3.1	4.3
150% overload current for 60 secs - A	2.3	3.5	4.7	6.5
Typical full load input current - A*	5.6	6.5	8.8	11.4
Typical inrush current - A** (duration <10ms)	100			
Drive power losses at 230Vac at 6kHz switching frequency - W	18	24	37	56
Weight - kg/lb	1.1/2.4		1.25/2.75	
Cooling fan fitted	No			

Table 3.1 Commander SE Size 1

* See section 3.1.1.

** For an explanation of inrush current, see section 3.1.2.

MODEL	SE11200...			
	025	037	055	075
Recommended input supply fuse - A	6	10	16	
Control cable	mm ²		≥ 0.5	
	AWG		20	
Recommended input cable	mm ²		1.0	1.5
	AWG		16	14
Recommended motor cable	mm ²		1.0	
	AWG		16	

Table 3.2 Recommended supply fuses and cables

MODEL	SE2D200...							
	075		110		150		220	
AC supply voltage and frequency	Single or 3 phase 200 to 240V +/- 10%, 48 to 62Hz							
Input displacement factor (cos ϕ)	>0.97							
Nominal motor power - kW	0.75		1.1		1.5		2.2	
Nominal motor power - hp	1.0				2.0		3.0	
Output voltage and frequency	3 phase, 0 to input voltage, 0 to 1000Hz							
100% RMS output current - A	4.3		5.8		7.5		10.0	
150% overload current for 60 secs - A	6.5		8.7		11.3		15.0	
Typical full load input current - A* 1ph/3ph	11.0	5.5	15.1	7.9	19.3	9.6	26.2	13.1
Typical inrush current - A**(duration <10ms)	55				35			
Drive power losses at 230Vac at 6kHz switching frequency - W	54		69		88		125	
Weight - kg/lb	2.75 / 6							
Cooling fan fitted	No				Yes			

Table 3.3 Commander SE Size 2, 200V dual rated units

* See section 3.1.1.

** For an explanation of inrush current, see section 3.1.2.

MODEL	SE2D200...							
	075		110		150		220	
	1ph	3ph	1ph	3ph	1ph	3ph	1ph	3ph
Recommended input supply fuse - A	16	10	20	16	25	16	32	20
Control cable mm ²	≥ 0.5							
AWG	20							
Recommended input cable mm ²	1.5	1.0	2.5	1.5	2.5	1.5	4.0	2.5
AWG	14	16	12	14	12	14	10	12
Recommended motor cable mm ²	1.0						1.5	
AWG	16						14	
Recommended braking resistor cable mm ²	1.0						1.5	
AWG	16						14	

Table 3.4 Recommended supply fuses and cables

MODEL	SE2D200...			
	075	110	150	220
Minimum braking resistor value - Ω	50			40
Recommended braking resistor value - Ω	100		75	50
Resistor peak power rating - kW*	1.8		2.4	3.5

Table 3.5 Braking resistors

* Based on recommended braking resistor value.

NOTE

Before fitting a braking resistor please read the information on Braking, and the Warnings on High Temperatures and Overload Protection at the end of this section.

MODEL	SE23200400
AC supply voltage and frequency	3 phase 200 to 240V +/- 10%, 48 to 62Hz
Input displacement factor (cos ϕ)	>0.97
Nominal motor power - kW	4
Nominal motor power - hp	5
Output voltage and frequency	3 phase, 0 to input voltage, 0 to 1000Hz
100% RMS output current - A	17.0
150% overload current for 60 secs - A	25.5
Typical full load input current - A*	21
Typical inrush current - A** (duration <10ms)	35
Drive power losses at 230Vac at 6kHz switching frequency - W	174
Weight - kg/lb	2.75 / 6
Cooling fan fitted	Yes

Table 3.6 Commander SE Size 2, 200V Three phase units

* See section 3.1.1.

** For an explanation of inrush current, see section 3.1.2.

MODEL	SE23200400
Recommended input supply fuse - A	32
Control cable	mm ² \geq 0.5
	AWG 20
Recommended input cable	mm ² 4.0
	AWG 10
Recommended motor cable	mm ² 2.5
	AWG 12
Recommended braking resistor cable	mm ² 2.5
	AWG 12

Table 3.7 Recommended supply fuses and cables

MODEL	SE23200400
Minimum braking resistor value - Ω	30
Recommended braking resistor value - Ω	30
Resistor peak power rating - kW*	5.9

Table 3.8 Braking resistors

* Based on recommended braking resistor value.

NOTE

Before fitting a braking resistor please read the information on Braking, and the Warnings on High Temperatures and Overload Protection at the end of this section.

MODEL	SE23400...					
	075	110	150	220	300	400
AC supply voltage and frequency	3 phase 380 to 480V +/- 10%, 48 to 62Hz					
Input displacement factor (cos ϕ)	>0.97					
Nominal motor power - kW	0.75	1.1	1.5	2.2	3.0	4.0
Nominal motor power - hp	1.0		2.0	3.0		5.0
Output voltage and frequency	3 phase, 0 to input voltage, 0 to 1000Hz					
100% RMS output current - A	2.1	3.0	4.2	5.8	7.6	9.5
150% overload current for 60 secs - A	3.2	4.5	6.3	8.7	11.4	14.3
Typical full load input current - A*400V, 50Hz/480V, 60Hz	3.6	4.8	6.4	9.3	11	14
Typical inrush current - A** (duration <10ms)	90			60		
Drive power losses at 480Vac at 6kHz switching frequency - W	43	57	77	97	122	158
Weight - kg/lb	2.75 / 6					
Cooling fan fitted	No			Yes		

Table 3.9 Commander SE Size 2, 400V Three phase units

* See section 3.1.1.

** For an explanation of inrush current, see section 3.1.2.

MODEL	SE23400...					
	075	110	150	220	300	400
Recommended input supply fuse - A	10		16		20	
Control cable	mm ² ≥ 0.5					
	AWG 20					
Recommended input cable	mm ² 1.0		1.5		2.5	
	AWG 16		14		12	
Recommended motor cable	mm ² 1.0				1.5	
	AWG 16				14	
Recommended braking resistor cable	mm ² 1.5					
	AWG 14					

Table 3.10 Recommended fuses and cables

MODEL	SE23400...					
	075	110	150	220	300	400
Minimum braking resistor value - Ω	100			75		
Recommended braking resistor value - Ω	200			100		
Resistor peak power rating - kW*	3.4			6.9		

Table 3.11 Braking Resistors

* Based on recommended braking resistor value.

NOTE

Before fitting a braking resistor please read the information on Braking, and the Warnings on High Temperatures and Overload Protection at the end of this section.

MODEL	SE33200...	
	550	750
AC supply voltage and frequency	3 phase 200 to 240V +/-10%, 48 to 62Hz	
Input displacement factor (cos ϕ)	>0.97	
Nominal motor power - kW	5.5	7.5
Nominal motor power - hp	7.5	10.0
Output voltage and frequency	3 phase, 0 to input voltage, 0 to 1000Hz	
100% RMS output current - A	25.0	28.5
150% overload current for 60 secs - A	37.5	42.8
Typical full load input current - A*	22.8	24.6
Typical inrush current - A** (duration <10ms)	44	
Drive power losses at 230Vac at 6kHz switching frequency - W	230	305
Weight - kg/lb	6 / 13.2	
Cooling fan fitted	Yes	

Table 3.12 Commander SE Size 3, 200V units

* See section 3.1.1.

** For an explanation of inrush current, see section 3.1.2.

MODEL	SE33200...	
	550	750
Recommended input supply fuse - A	30	
Control cable	mm ²	
	≥ 0.5	
	AWG	
	20	
Recommended input cable	mm ²	
	4.0*	
	AWG	
	10*	
Recommended motor cable	mm ²	
	4.0*	
	AWG	
	10*	
Recommended braking resistor cable	mm ²	
	4.0	
	AWG	
	10	

Table 3.13 Recommended fuses and cables

*It is recommended that 6mm² / 8AWG cable is used to minimise volt drops when cable length greater than 100m are used

MODEL	SE33200...	
	550	750
Minimum braking resistor value - Ω	12.0	
Recommended braking resistor value - Ω	15.0	
Resistor peak power rating - kW*	11.8	

Table 3.14 Braking Resistors

* Based on recommended braking resistor value.

NOTE

Before fitting a braking resistor please read the information on Braking, and the Warnings on High Temperatures and Overload Protection at the end of this section.

MODEL	SE33400...	
	550	750
AC supply voltage and frequency	3 phase 380 to 480V +/-10%, 48 to 62Hz	
Input displacement factor (cos ϕ)	>0.97	
Nominal motor power - kW	5.5	7.5
Nominal motor power - hp	7.5	10.0
Output voltage and frequency	3 phase, 0 to input voltage, 0 to 1000Hz	
100% RMS output current - A	13.0	16.5
150% overload current for 60 secs - A	19.5	24.8
Typical full load input current - A*	13.0	15.4
Typical inrush current - A** (duration <10ms)	80	
Drive power losses at 480Vac at 6kHz switching frequency - W	190	270
Weight - kg/lb	6 / 13.2	
Cooling fan fitted	Yes	

Table 3.15 Commander SE Size 3, 400V units

* See section 3.1.1.

** For an explanation of inrush current, see section 3.1.2.

MODEL		SE33400...	
		550	750
Recommended input supply fuse - A		16	20
Control cable	mm ²	≥ 0.5	
	AWG	20	
Recommended input cable	mm ²	2.5	
	AWG	12	
Recommended motor cable	mm ²	2.5	
	AWG	12	
Recommended braking resistor cable	mm ²	2.5	
	AWG	12	

Table 3.16 Recommended fuses and cables

MODEL	SE33400...	
	550	750
Minimum braking resistor value - Ω	39.0	
Recommended braking resistor value - Ω	50	
Resistor peak power rating - kW*	13.8	

Table 3.17 Braking Resistors

* Based on recommended braking resistor value.

NOTE

Before fitting a braking resistor please read the information on Braking, and the Warnings on High Temperatures and Overload Protection at the end of this section.

MODEL	SE4340...		
	1100	1500	1850
AC supply voltage and frequency	3 phase 380 to 480V +/-10%, 48 to 62Hz		
Input displacement factor (cosφ)	>0.97		
Nominal motor power - kW	11	15	18.5
Nominal motor power - hp	15	20	25
Output voltage and frequency	3 phase, 0 to input voltage, 0 to 1000Hz		
100% RMS output current - A	24.5	30.5	37
150% overload current for 60 secs - A	36.75	45.75	55.5
Typical full load input current - A*	23	27.4	34
Typical inrush current - A** (duration <10ms)	40		
Drive power losses at 480Vac at 6kHz*** switching frequency - W	400	495	545
Weight - kg/lb	11 / 24.2		
Cooling fan fitted	Yes		

Table 3.18 Commander SE Size 4, 400V units

* See section 3.1.1.

** For an explanation of inrush current, see section 3.1.2.

*** 3kHz for 18.5kW

MODEL	SE4340...		
	1100	1500	1850
Recommended input supply fuse - A	32	40	
Control cable mm ²	≥0.5		
AWG	20		
Recommended input cable mm ²	4.0		6.0
AWG	10		8
Recommended motor cable mm ²	4.0	6.0	
AWG	10	8	
Recommended braking resistor cable mm ²	6.0		
AWG	8		

Table 3.19 Recommended fuses and cables

MODEL	SE4340...		
	1100	1500	1850
Minimum braking resistor value - Ω	24		
Recommended braking resistor value - Ω	40	30	24
Resistor peak power rating - kW*	17.2	23	28.7

Table 3.20 Braking Resistors

* Based on recommended braking resistor value.

NOTE

Before fitting a braking resistor please read the information on Braking, and the Warnings on High Temperatures and Overload Protection at the end of this section.

MODEL	SE5340...		
	2200	3000	3700
AC supply voltage and frequency	Three phase 380 - 480V +/- 10% 48 - 62Hz		
Input displacement factor (cos ϕ)	>0.97		
Nominal motor power - kW	22	30	37
Nominal motor power - hp	30	40	50
Output voltage and frequency	3 phase, 0 to input voltage, 0 to 1000Hz		
100% RMS output current - A	46	60	70
150% overload current for 60 secs - A	69	90	105
Typical full load input current - A*	40	52	66
Typical inrush current - A**	28		
Typical inrush current duration - ms	49		
Drive power losses at 480Vac at 3kHz switching frequency - W	730	950	1090
Weight - kg/lb	22 / 49		
Cooling fan fitted	Yes		

Table 3.21 Commander SE Size 5 units

* See section 3.1.1.

** For an explanation of inrush current, see section 3.1.2.

MODEL	SE5340...		
	2200	3000	3700
Recommended input supply fuse - A	60	70	80
Control cable	mm ² 0.5		
	AWG 20		
Recommended input cable	mm ² 10	16	25
	AWG 6	4	4
Recommended motor cable	mm ² 10	16	25
	AWG 6	4	4
Recommended braking resistor cable	mm ² 10	16	25
	AWG 6	4	4

Table 3.22 Recommended fuses and cables

MODEL	SE5340...		
	2200	3000	3700
Minimum braking resistor value - Ω	10		
Recommended braking resistor value - Ω	20	12	
Resistor peak power rating - kW*	34.5	57.5	

Table 3.23 Braking resistors

* Based on recommended braking resistor value.

NOTE

Before fitting a braking resistor please read the information on Braking, and the Warnings on High Temperatures and Overload Protection at the end of this section.



Braking Resistors - High Temperatures

Braking resistors can reach high temperatures. Locate braking resistors so that damage cannot result. Use cable having insulation capable of withstanding high temperatures.



Braking Resistors - Overload Protection

It is essential that an overload protection device is incorporated in the braking resistor circuit. This is described in section 5.1.1 *Thermal Protection Circuit for an Optional Braking Resistor*.

3.1.1 *Input current

The input current values given could be exceeded where the supply fault current is greater than 5kA or the phase voltages are not balanced. In these cases, input line reactors are recommended. See section 4.4.3 *Use of line reactors* on page 26.

3.1.2 **Temperature effects on inrush currents

Size 1 - 4

Due to the design of the inrush circuit, the inrush current will be lower on the first power up of the drive after a period of non-use and when the drive is cold. The inrush current will increase when the time between power ups is short and the internal ambient temperature within the drive is high.

3.2 General data

IP Rating

Size 1:

IP20

The Ingress Protection rating is applicable to the drive when the supplied rubber grommets are fitted into the gland plate.

Sizes 2, 3 & 4:

IP20

The Ingress Protection rating is applicable to the drive when the supplied rubber grommets are fitted into the gland plate and the drive is mounted on a solid flat surface.

Size 5:

IP00 - Gland plate not fitted

IP10 - Gland plate fitted, cable glands not fitted (unused holes covered)

IP20 - Gland plate fitted, cable glands fitted (blinking caps covering unused holes)

NEMA Enclosure Rating

Size 1:

The drive has a NEMA 1 enclosure rating when a suitable method of cable entry is used, e.g. conduit

Sizes 2, 3 & 4:

The drive has a NEMA 1 enclosure rating when mounted on a solid flat surface and a suitable method of cable entry is used, e.g. conduit

Size 5:

The drive does not have a NEMA 1 enclosure rating.


NEMA 1 is an enclosure constructed for indoor use to provide a degree of protection to personnel against incidental contact with the enclosed equipment and to provide a degree of protection against falling debris.



If the drive is not mounted as indicated, hazardous live parts will be exposed and the IP Rating or NEMA 1 enclosure rating of the drive will be invalid.

Input phase imbalance:	Phase imbalance not to exceed 2% negative phase sequence
Ambient temperature:	-10°C to +40°C (14°F to 104°F) at 6kHz switching frequency. -10°C to +50°C (14°F to 122°F) at 3kHz switching frequency with derating on some models. -10°C to +40°C (14°F to 104°F) at 3kHz switching frequency for SE4, 18.5kW and SE Size 5. See <i>Commander SE Advanced User Guide</i> for Derating Curves.
Storage temperature:	-40°C to +60°C (-40°F to 140°F) for 12 months max
Altitude:	Reduce the normal full-load current by 1% for every 100m (325ft) above 1000m (3250ft) to a maximum of 4000m (13000ft).
Humidity:	Maximum relative humidity 95% (non-condensing)
Materials:	Flammability rating of main enclosure:UL94-5VA (Size 1 to 4) Flammability rating of main enclosure:UL94-V0 (Size 5) Grommets:UL94-V1
Vibration (random):	Unpackaged - tested to 0.01g ² /Hz (equivalent to 1.2g rms) from 5 to 150Hz for 1 hour in each of 3 axes in accordance with IEC68-2-34 and IEC68-2-36.
Vibration (sinusoidal)	Unpackaged - tested from 2-9Hz, 3.5mm displacement; 9-200Hz 10m/s ² acceleration; 200-500Hz, 15m/s ² acceleration. Duration - 15 minutes in each of 3 axes. Sweep rate 1 octave/minute. Test in accordance with IEC68-2-6.
Bump:	Packaged - tested to 40g, 6ms, 100 times/direction for all 6 directions as in IEC68-2-29 Unpackaged - tested to 25g, 6ms, 100 times/direction for all 6 directions in accordance with IEC68-2-29
Frequency accuracy:	0.01%
Resolution:	0.1Hz
Output frequency range:	0 to 1000Hz
Starts per hour:	By using the electronic control terminals: Unlimited By switching of the supply: 20 starts per hour maximum (3 minute intervals between starts)
Power up delay:	1.5 seconds maximum (Allow at least 1 second for Sizes 1 to 4 and 1.5 seconds for Size 5 before monitoring the state of the status relay contacts, communicating with the drive via serial communications etc.)

Serial Communications:	2-wire EIA485 via RJ45 connector ANSI and Modbus RTU protocols supported
Switching Frequencies:	3, 6, and 12 kHz are available with Intelligent Thermal Management software automatically changing the switching frequencies depending on load conditions, heatsink temperature and output frequency, to prevent heatsink overtemperature trips.
EMC:	EN50082-2 and EN61800-3 for immunity EN50081-1*, EN50081-2 and EN61800-3 first environment, with optional RFI filter. See section 3.3 and section 4.5. * Size 1 units only.



This is a product of the restricted distribution class according to IEC61800-3.
In a domestic environment this product may cause radio interference in which case the user may be required to take adequate measures.

3.3 RFI Filters

RFI filters are available as optional extra parts where required.

Used with	Filter Part No	Filter Type			Mounting		Max motor cable length (m)
		Standard	Low leakage	Low cost	Footprint	Side	
SE11200025 to SE11200075	4200-6101			Y		Y	20
	4200-6102	Y			Y	Y	75
	4200-6103		Y		Y	Y	15

Table 3.24 Commander SE Size 1

Used with	Filter Part No	Filter Type			Mounting		Max motor cable length (m)
		Standard	Low leakage	Low cost	Footprint	Side	
SE2D200075 to SE2D200220	4200-6201	Y			Y	Y	100
	4200-6204			Y		Y	50
	4200-6205		Y		Y	Y	15

Table 3.25 Commander SE Size 2 - 200V, 26A, 1 phase

Used with	Filter Part No	Filter Type			Mounting		Max motor cable length (m)
		Standard	Low leakage	Low cost	Footprint	Side	
SE2D200075 to SE2D200220	4200-6202	Y			Y	Y	100
	4200-6304			Y		Y	15
	4200-6207		Y		Y	Y	45

Table 3.26 Commander SE Size 2 - 200 / 400V, 16A, 3 phase

Used with	Filter Part No	Filter Type			Mounting		Max motor cable length (m)
		Standard	Low leakage	Low cost	Footprint	Side	
SE23400075 to SE23400400	4200-6202	Y			Y	Y	100
	4200-6304			Y		Y	15
	4200-6207		Y		Y	Y	20

Table 3.27 Commander SE Size 2 - 200 / 400V, 16A, 3 phase

Used with	Filter Part No	Filter Type			Mounting		Max motor cable length (m)
		Standard	Low leakage	Low cost	Footprint	Side	
SE23200400	4200-6203	Y			Y	Y	100
	4200-6303			Y		Y	20
	4200-6209		Y		Y	Y	45

Table 3.28 Commander SE Size 2 - 200V, 26A, 3 phase

Used with	Filter Part No	Filter Type		Mounting		Max motor cable length (m)
		Standard	Low cost	Footprint	Side	
SE33200550 to SE33200750	4200-6302	Y		Y	Y	100
	4200-6303		Y		Y	15

Table 3.29 Commander SE Size 3 - 200V, 30A

Used with	Filter Part No	Filter Type		Mounting		Max motor cable length (m)
		Standard	Low cost	Footprint	Side	
SE33400550 to SE33400750	4200-6301	Y		Y	Y	100
	4200-6304		Y		Y	15

Table 3.30 Commander SE Size 3 - 400V, 17A

Used with	Filter Part No	Filter Type		Mounting		Max motor cable length (m)
		Standard	Low cost	Footprint	Side	
SE43401100 to SE43401500	4200-6401	Y		Y	Y	100
	4200-6402		Y		Y	15
SE43401850	4200-6403	Y		Y	Y	100
	4200-6404		Y		Y	20

Table 3.31 Commander SE Size 4

Used with	Filter Part No	Filter Type	Mounting	Max motor cable length (m)
		Standard	Bookcase	
SE53402200	4200-6116	Y	Y	100
SE53403000	4200-6117	Y	Y	100
SE53403700	4200-6106	Y	Y	100

Table 3.32 Commander SE Size 5

For complete EMC information, refer to section 4.5 *Electromagnetic compatibility (EMC)* on page 27.

4 Installing the drive

4.1 Safety information



Follow the instructions

The mechanical and electrical installation instructions must be adhered to. Any questions or doubt should be referred to the supplier of the equipment. It is the responsibility of the owner or user to ensure that the installation of the drive and any external option unit, and the way in which they are operated and maintained, comply with the requirements of the Health and Safety at Work Act in the United Kingdom or applicable legislation and regulations and codes of practice in the country in which the equipment is used.



Competence of the installer

The drive must be installed by professional assemblers who are familiar with the requirements for safety and EMC. The assembler is responsible for ensuring that the end product or system complies with all the relevant laws in the country where it is to be used.

4.2 Planning the installation

The following considerations must be made when planning the installation:

Access

Access must be restricted to authorised personnel only. Safety regulations which apply at the place of use must be complied with. If it is a requirement that authorised personnel manually adjust drive settings while power is applied, then the drive itself must meet the requirements of IP20. See section 3.2 *General data on page 12* for details.

Environmental protection

The drive must be protected from:

- moisture, including dripping water or spraying water and condensation. An anti-condensation heater may be required, which must be switched off when the drive is running.
- contamination with electrically conductive material
- temperature beyond the specified operating and storage ranges

Cooling

The heat produced by the drive must be removed without its specified operating temperature being exceeded. Note that a sealed enclosure gives much reduced cooling compared with a ventilated one, and may need to be larger and/or use internal air circulating fans. For further information on enclosure design, please refer to the *Commander SE Advanced User Guide*.

Electrical safety

The installation must be safe under normal and fault conditions. Electrical installation instructions are given later in this chapter.

Fire protection

The drive enclosure is not classified as a fire enclosure. A separate fire enclosure must be provided.

Electromagnetic compatibility

Variable speed drives are powerful electronic circuits which can cause electromagnetic interference if not installed correctly with careful attention to the layout of the wiring.

Some simple routine precautions can prevent disturbance to typical industrial control

equipment.

If it is necessary to meet strict emission limits, or if it is known that electromagnetically sensitive equipment is located nearby, then full precautions must be observed. These will include the use of RFI filters at the drive inputs, which must be located very close to the drives. Space must be made available for the filters and allowance made for carefully segregated wiring. Both levels of precautions are given further on in this chapter.

Hazardous areas

The drive must not be located in a classified hazardous areas unless it is installed in an approved enclosure and the installation is certified.

4.3 Mechanical installation

4.3.1 Drive and Mounting Dimensions

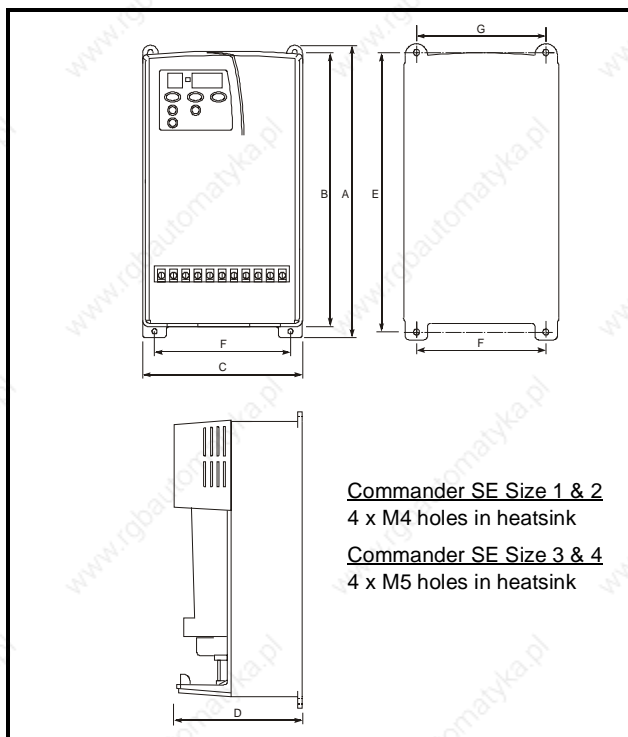


Figure 4.1 Size 1 to 4 Drive and mounting dimensions

Drive Size	A		B		C		D		E		F		G	
	mm	in	mm	in	mm	in	mm	in	mm	in	mm	in	mm	in
1	191	7 ³³ / ₆₄	175	6 ⁵⁷ / ₆₄	102	4 ¹ / ₆₄	130	5 ⁷ / ₆₄	181.5	7 ⁹ / ₆₄	84	3 ⁵ / ₁₆	84	3 ⁵ / ₁₆
2	280	11 ¹ / ₆₄	259	10 ³ / ₁₆	147	5 ²⁵ / ₃₂	130	5 ⁷ / ₆₄	265	10 ⁷ / ₁₆	121.5	4 ²⁵ / ₃₂	121.5	4 ²⁵ / ₃₂
3	336	13 ⁷ / ₃₂	315	12 ¹³ / ₃₂	190	7 ³¹ / ₆₄	155	6 ⁷ / ₆₄	320	12 ¹⁹ / ₃₂	172	6 ²⁵ / ₃₂	164	6 ²⁹ / ₆₄
4	412	16 ⁷ / ₃₂	389	15 ⁵ / ₁₆	250	9 ²⁷ / ₃₂	185	7 ⁹ / ₃₂	397	15 ⁵ / ₈	228	8 ⁶³ / ₆₄	217	8 ³⁵ / ₆₄

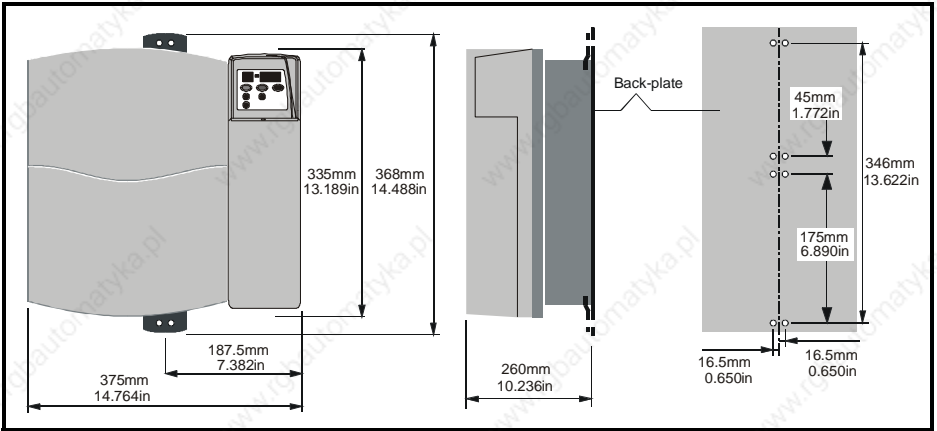


Figure 4.2 Surface mounting Size 5 units

NOTE The drive should be mounted vertically. A mounting template is provided on the drive packing carton to aid installation.

NOTE When surface mounting a model size 5, allow a clearance of 150mm (6in) above the drive; this is for dismantling. A minimum clearance of 100mm (4in) is required for ventilation.

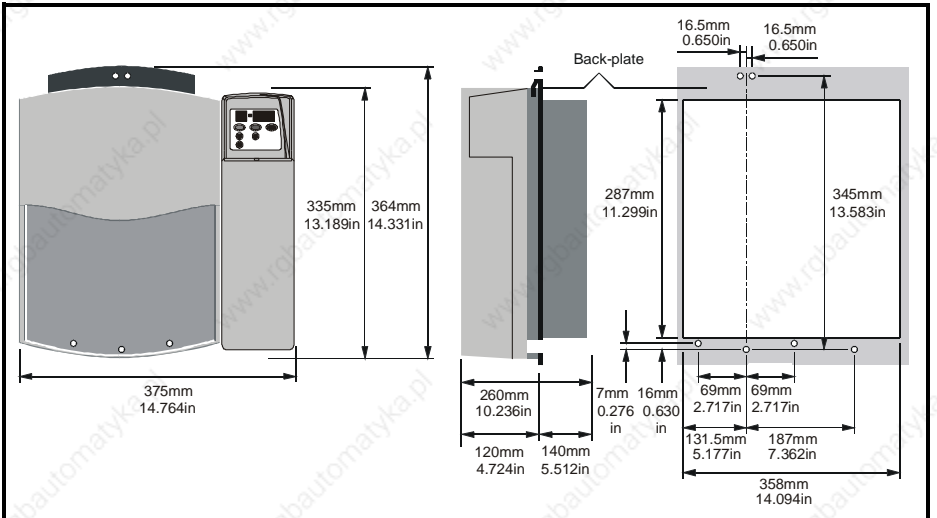


Figure 4.3 Through-panel mounting Size 5 units

Use M6 x 12mm max. (or equivalent) thread-forming screws to screw into holes in the heatsink, or tap the holes to a suitable thread size.

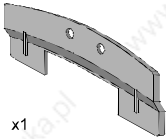
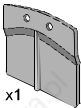
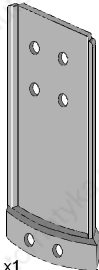
Through-hole mounting bracket	Surface mounting bracket	
 <p>x1</p>	 <p>x1</p>	 <p>x1</p>

Table 4.1 Size 5 Mounting brackets

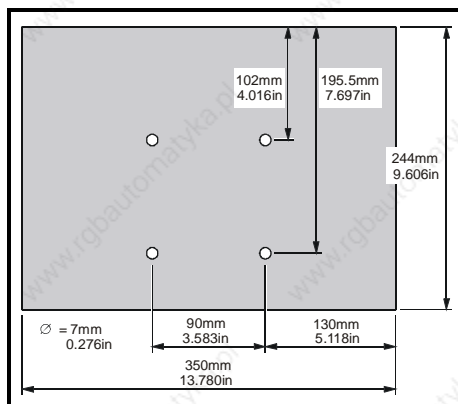


Figure 4.4 Size 5 baffle plate

When a Commander SE size 5 is through-panel mounted a baffle plate is required to ensure the correct level of air flow is maintained through the heatsink. The fitting of a baffle plate causes the heatsink to act as a chimney; this enhances the air flow along the heatsink fins to aid cooling (this naturally occurs when the drive is surface mounted). You may make a baffle plate from any suitable conducting or non-conducting material. Use M6 x 12mm max (or equivalent) thread-forming screws to screw into the holes in the heatsink, or tap the holes to a suitable thread size.

4.3.2 Commander SE standard and low earth leakage Footprint/ Side mounting RFI Filter:

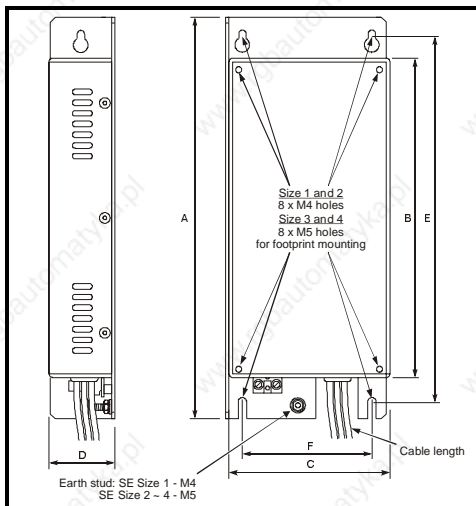


Figure 4.5 RFI filter dimensions

Drive Size	A		B		C		D		E		F		Cable Length	
	mm	in	mm	in	mm	in	mm	in	mm	in	mm	in	mm	in
1	242	9 ¹⁷ / ₃₂	195	7 ⁴³ / ₆₄	100	3 ¹⁵ / ₁₆	40	1 ³⁷ / ₆₄	225	8 ⁷ / ₈	80	3 ⁵ / ₃₂	190	7 ³¹ / ₆₄
2	330	13	281	11 ¹ / ₁₆	148	5 ¹³ / ₁₆	45	1 ⁴⁹ / ₆₄	313	12 ²¹ / ₆₄	122	4 ⁵¹ / ₆₄	250	9 ²⁷ / ₃₂
3	385	15 ⁵ / ₃₂	336	13 ¹⁵ / ₆₄	190	7 ³¹ / ₆₄	50	1 ³¹ / ₃₂	368	14 ³¹ / ₆₄	164	6 ²⁹ / ₆₄	270	10 ⁵ / ₈
4	467	18 ²⁵ / ₆₄	414	16 ¹⁹ / ₆₄	246	9 ¹¹ / ₁₆	55*	2 ¹¹ / ₆₄	448	17 ⁴¹ / ₆₄	215	8 ¹⁵ / ₃₂	320	12 ¹⁹ / ₃₂

* 60mm for Size 4, 18.5kW; 4200-6403

4.3.3 Commander SE Size 1 Low Cost RFI Filter mounting dimensions, 4200-6101.

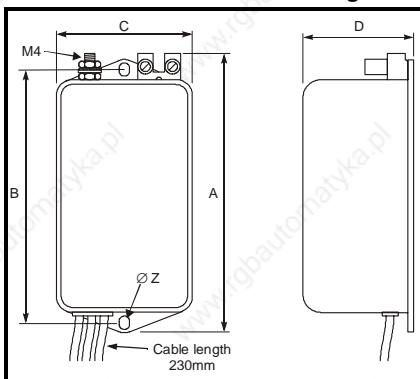


Figure 4.6 Size 1 Low cost filter dimensions

A		B		C		D		Z Ø	
mm	in	mm	in	mm	in	mm	in	mm	in
113.5	4 ¹⁵ / ₃₂	103	4 ¹ / ₁₆	58	2 ⁹ / ₃₂	45.5	1 ⁵¹ / ₆₄	4.4	3 ³ / ₁₆

4.3.4 Commander SE Size 2 and 3 Low cost single and three phase RFI Filter mounting dimensions, 4200-6204 and 4200-6304.

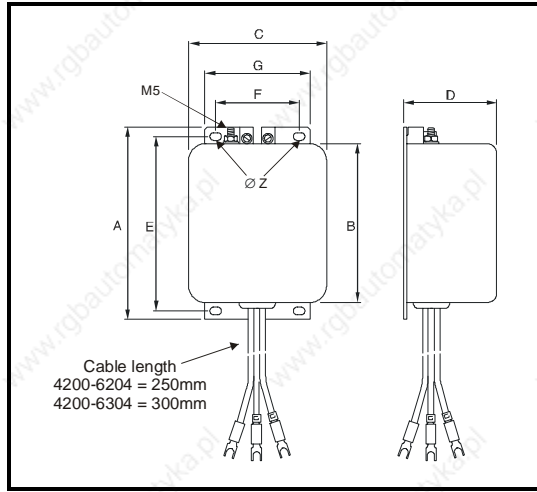


Figure 4.7 RFI filter dimensions

A		B		C		D		E		F		G		Ø Z	
mm	in	mm	in	mm	in	mm	in	mm	in	mm	in	mm	in	mm	in
119	4 ¹¹ / ₁₆	98.5	3 ⁷ / ₈	85.5	3 ²¹ / ₆₄	57.6	2 ¹⁷ / ₆₄	109	4 ¹⁹ / ₆₄	51	2	66	2 ¹⁹ / ₃₂	4.3 x 7.5	3 ¹ / ₁₆ x 5 ⁵ / ₁₆

4.3.5 Commander SE Size 2, 3 and 4 Low cost three phase RFI Filter mounting dimensions, 4200-6303, 4200-6402 & 4200-6404.

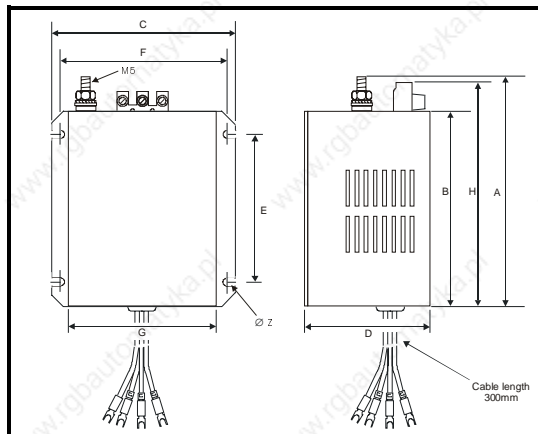


Figure 4.8 RFI filter dimensions

	A		B		C		D		E		F		G		H		Ø Z	
	mm	in	mm	in	mm	in	mm	in	mm	in	mm	in	mm	in	mm	in	mm	in
4200-6303	133	5 ¹⁵ / ₆₄	120	4 ²³ / ₃₂	118	4 ⁴¹ / ₆₄	70	2 ³ / ₄	80	3 ⁵ / ₃₂	103	4 ¹ / ₁₆	90	3 ³⁵ / ₆₄	130.6	5 ⁹ / ₆₄	6.5	1 ¹ / ₄
4200-6402 4200-6404	143	5 ⁵ / ₈	130	5 ¹ / ₆₄	128	5 ¹ / ₃₂	80	3 ⁵ / ₃₂	80	3 ⁵ / ₃₂	113	4 ²⁹ / ₃₄	100	3 ¹⁵ / ₁₆	143	5 ⁵ / ₈	6.5	1 ¹ / ₄

4.3.6 SE53402200 bookcase mounted filter, 4200-6116

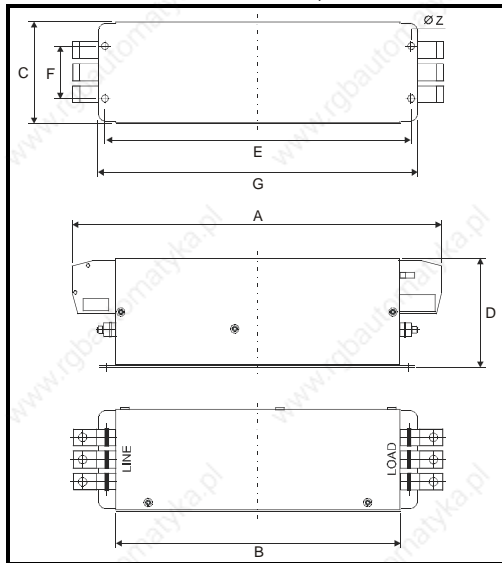


Figure 4.9 RFI filter dimensions

4.3.7 SE53403000 ~ SE53403700 bookcase mounted filter, 4200-6117, 4200-6106

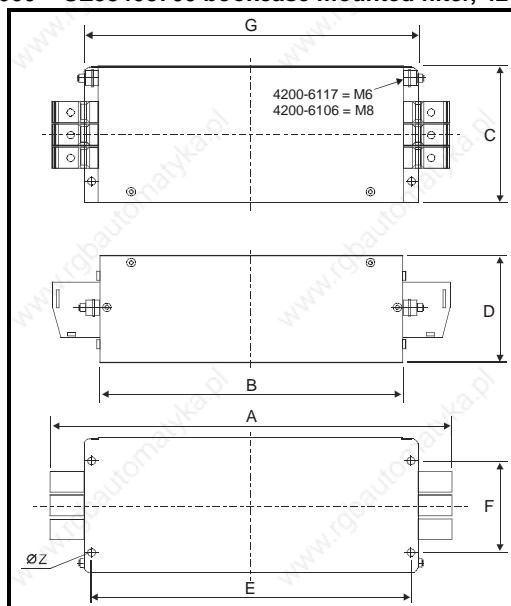


Figure 4.10 RFI filter dimensions

	A		B		C		D		E		F		G		Ø Z	
	mm	in	mm	in	mm	in	mm	in	mm	in	mm	in	mm	in	mm	in
4200-6116	337	13.27	259.5	10.22	90	3.54	100	3.94	275	10.83	50	1.97	290	11.42	7	0.28
4200-6117	377	14.84	300	11.81	150	5.9	103	4.05	315	12.4	105	4.13	330	12.99	7	0.28
4200-6106	380	14.96	294	11.57	150	5.9	107	4.21	310	12.2	105	4.13	325	12.79	7	0.28

4.3.8 Minimum Mounting Clearances

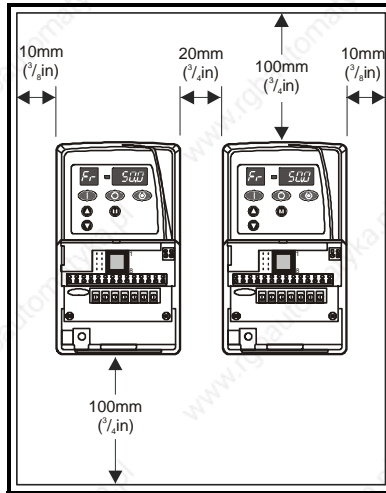


Figure 4.11 Minimum mounting clearances (applies to all drive sizes)

4.4 Electrical installation



WARNING

Electric shock risk

The voltages present in the following locations can cause severe electric shock and may be lethal:

- AC supply cables and connections
- Output cables and connections
- Many internal parts of the drive, and external option units



WARNING

Isolation device

The AC supply must be disconnected from the drive using an approved isolation device before any cover is removed from the drive or before any servicing work is performed.



WARNING

STOP function

The STOP function does not remove dangerous voltages from the drive or any external option units.



WARNING

Stored charge

The drive contains capacitors that remain charged to a potentially lethal voltage after the AC supply has been disconnected. If the drive has been energised, the AC supply must be isolated at least ten minutes before work may continue.

Normally, the capacitors are discharged by an internal resistor. Under certain, unusual fault conditions, it is possible that the capacitors may fail to discharge, or be prevented from being discharged by a voltage applied to the output terminals. If the drive has failed in a manner that causes the display to go blank immediately, it is possible the capacitors will not be discharged. In this case, consult Control Techniques or their authorised distributor.



AC supply by plug and socket

Special attention must be given if the drive is installed in equipment which is connected to the AC supply by a plug and socket. The AC supply terminals of the drive are connected to the internal capacitors through rectifier diodes which are not intended to give safety isolation. If the plug terminals can be touched when the plug is disconnected from the socket, a means of automatically isolating the plug from the drive must be used (eg. a latching relay).

4.4.1 AC supply requirements

The following types of AC supply are suitable.

Single phase models:

- Single phase (i.e. between one phase and neutral of a star-connected three phase supply)
- Between two phases of a three phase supply (any one phase can be grounded)

Three phase models:

- Three phase star or delta supply of the correct voltage (any one phase or neutral can be grounded)

Dual rated 200V models:

- Any of the above

NOTE

The input current differs for single phase and three phase supplies.

Supply voltage and current information is given in Chapter 3 *Technical Data*.

4.4.2 Cables and fuses

Recommended cable sizes are given in Chapter 3 *Technical Data*. They are only a guide. Refer to local wiring regulations for the correct size of cables. In some cases a larger cable is required to avoid excessive voltage drop.

Use 105°C (221°F) (UL 60/75°C temp rise) pvc-insulated cable with copper conductors having a suitable voltage rating, for the following power connections:

- AC supply to RFI filter (when used)
- AC supply (or RFI filter) to drive
- Drive to motor
- Drive to braking resistor



Fuses

The AC supply to the drive must be fitted with suitable protection against overload and short-circuits. The tables in Chapter 3 *Technical Data* show recommended fuse ratings. Failure to observe this requirement will cause risk of fire.

A fuse or other protection must be included in all live connections to the AC supply.

An MCB (miniature circuit breaker) or MCCB (moulded case circuit breaker) with type C tripping characteristics and the same rating as the fuse(s), may be used in place of the fuse(s), on condition that the fault current clearing capacity is sufficient for the installation.

Fuse Types

Europe: Type gG fuses complying with EN60269 parts 1 and 2.

USA: Bussman Limitron KTK series, class CC fast acting fuses.

Ground connections

The drive must be connected to the system ground of the AC supply. The ground wiring must conform to local regulations and codes of practice.



The ground loop impedance must conform to the requirements of local safety regulations. The ground connections must be inspected and tested at appropriate intervals.

Earth and ground leakage

Sizes 1 ~ 4

The drive has a very small leakage current between the power lines and ground, which is of no consequence.

Size 5

Ground leakage current is typically 9mA*. A fixed ground connection must be made before the AC power is applied. In some applications, safety regulations require a duplicate ground connection.

*9mA at 380Vac ~ 415V 50Hz AC supply. Measured by the method described in IEC950 Annex D.



The RFI filter has a higher leakage current, data is given in section 4.5.4, Tables 4.13 to 4.17. When the standard and low cost filters are used, a permanent fixed ground connection must be provided which does not pass through a connector or flexible power cord.

Motor cables

For routine EMC precautions

Use either of the following:

- Cables containing three power conductors plus a ground conductor
- Three separate power conductors plus a ground conductor

For full EMC precautions, where required (see section 4.5.2)

Use shielded (screened) or steel-wire armoured cable having three power conductors plus a ground conductor.



If the cable between the drive and the motor is to be interrupted by a contactor or circuit breaker, ensure that the drive is disabled before the contactor or circuit breaker is opened or closed. Severe arcing may occur if this circuit is interrupted with the motor running at high current and low speed.

Maximum motor cable lengths

The capacitive loading of the drive by the motor cable means that the cable length limits shown in Table 4.2 must be observed. Failure to do so can result in spurious OI.AC tripping of the drive. If longer cable lengths are required, consult your local Drive Centre or Distributor.

The maximum cable lengths were measured using cable with capacitance of 412pF/m.

Drive Size	Maximum motor cable length	
	Meters	Feet
1	75	246
2	100	330
3	150	495
4	150	495
5	120*	394*

Table 4.2 Maximum motor cable lengths

* This cable length is for 3kHz switching frequency. The cable length reduces in proportion to the switching frequency; e.g. at 6kHz, it is reduced by a factor of 2 to 60m.

High Capacitance Cables

Most cables have an insulating jacket between the cores and the armour or shield; these cables have a low capacitance and are recommended. Cables that do not have

an insulating jacket tend to have high capacitance.

If a high capacitance cable is used, the maximum cable lengths in Table 4.2 should be halved.

For further information please refer to the *Commander SE Advanced User Guide*.

Multiple Motors

For advice on multiple motor applications where a number of small motors are connected to the output of one drive, please refer to the *Commander SE Advanced User Guide*.

4.4.3 Use of line reactors

Line reactors can be used to reduce supply harmonics and also should be used if any of the following conditions apply:

- Supply capacity exceeds 200kVA
- Fault current exceeds 5kA
- Power-factor correction equipment is connected close to the drives
- Large DC drives having no or ineffective line reactors connected to the supply
- Direct on-line started motor(s) are connected to the supply and, when any of these motors are started, a dip is produced in excess of 20% of the actual supply voltage

During any of the above conditions, excessive peak current may flow in the input bridge. This may cause nuisance drive tripping or, in extreme cases, failure of the input bridge.

A line reactor should then be connected in each phase of the supply to the input bridge. Line reactor(s) add the required impedance to the AC supply in order to reduce current transients to a level that can be tolerated by the input bridge. An impedance value of 2% is usually recommended.

Three individual reactors, or a single three-phase reactor should be used. Each network of drives must have its own reactor(s).



RFI filters (for EMC purposes) do not give adequate protection against these conditions.

4.4.4 AC Line reactor values

Drives used with	Reactor part number	Input phases	Inductance	Contin-uous rms current	Peak current	Dimensions (mm)		
			mH	A	A	L	D	H
SE11200025, SE11200037	4402-0224	1	2.25	6.5	13	72	65	90
SE11200055, SE11200075, SE2D200075, SE2D200110	4402-0225	1	1.0	15.1	30.2	82	75	100
SE2D200150, SE2D200220	4402-0226	1	0.5	26.2	52.4	82	90	105
SE23400075, SE23400110, SE23400150	4402-0227	3	2.0	7.9	15.8	150	90	150
SE2D200075, SE2D200110, SE2D200150, SE23400220, SE23400300, SE23400400, SE33400550, SE33400750	4402-0228	3	1.0	15.4	47.4	150	90	150
SE23200400, SE2D200220, SE33200550, SE33200750	4402-0229	3	0.4	24.6	49.2	150	90	150
SE43401100, SE43401500	4402-0232	3	0.6	27.4	54.8	180	100	190
*SE43401850, *SE53402200	4400-0240	3	0.45	46	92	190	150	225
*SE53403000, *SE53403700	4400-0241	3	0.3	74	148	250	150	275

Table 4.3 AC Line reactor values

NOTE

Commander SE sizes 3, 4 and 5 drives include DC chokes, AC reactors are only required for harmonic reduction.

NOTE

***These input reactors are not stocked by Control Techniques. Therefore they should be ordered directly from the manufacturer, Skot Transformers, or sourced locally.**

sales@skot.co.uk

They can be ordered using the above part numbers or Skot reference numbers:

4400-0240 = 35232

4400-0241 = 35233

Line reactors also improve the input current waveform and reduce the input current harmonic levels. Further information is included in the EMC Data sheet which is available from Control Techniques' Drive Centres or Distributors.

4.4.5 Input line reactors for Harmonics standards EN61000-3-2 & IEC61000-3-2

The following input line reactors allow the Commander SE 0.25 - 0.55kW drives to conform to harmonic standards EN61000-3-2 and IEC61000-3-2

Drive	Reactor part number	Power de-rating	Input power	Inductance	Continuous rms current
			W	mH	
SE12200025	4400-0239	None	374	4.5	2.4
SE12200037	4400-0238	None	553	9.75	3.2
SE12200055	4400-0237	18%	715	16.25	4.5

EN61000-3-2 and IEC61000-3-2 applies to equipment with a supply voltage of 230Vac and a line current up to 16A, single or three phase. Professional equipment with rated input power exceeding 1kW has no limits - this applies to the 0.75kW drive.

Further information on EN61000-3-2 and IEC61000-3-2 is included on the EMC data sheets available from your local Control Techniques Drive Centre or distributor.

4.4.6 Voltage fluctuation (Flicker) standard EN61000-3-3 (IEC61000-3-3)

Those models which fall within the scope of EN61000-3-3, as stated in the Declaration of Conformity, conform to the requirements for manual switching, i.e. the voltage dip caused when a drive at room temperature is switched on is within the permitted limits.

The drive does not of itself cause periodic voltage fluctuation in normal operation. The installer must ensure that the control of the drive is such that periodic fluctuations in supply current do not infringe the flicker requirements where applicable. Note that large periodic load fluctuations in the frequency range of between 1Hz and 30Hz are particularly inclined to cause irritating lighting flicker and are subject to stringent limits under EN61000-3-3.

4.5 Electromagnetic compatibility (EMC)

This section gives installation guidelines for ensuring electromagnetic compatibility. Further detailed information is provided in the EMC Data sheets which are available from Control Techniques' Drive Centres or distributors.

The drive meets the standards for electromagnetic immunity stated in section 3.2 without any special installation precautions. To prevent possible nuisance tripping, it is recommended that all inductive circuits associated with the drive, for example relay coils, electromagnetic brakes etc. should be fitted with appropriate suppression.

The following precautions should be taken to prevent the drive from causing interference with other electronic equipment.

For general use the guidelines in section 4.5.1 *Routine EMC precautions* should be followed. These are sufficient to prevent interference to general purpose industrial and similar equipment of good quality recent design.

Section 4.5.2 *Full EMC precautions* should be followed in the following cases:

- When compliance with strict emission standards such as EN50081-1 or EN50081-2 is required.
- Where sensitive radio receiving or similar equipment is in use nearby.
- Where sensitive electronic equipment with poor electromagnetic immunity is in use nearby.

4.5.1 Routine EMC precautions

The routine precautions are based on the following principles:

1. The motor cable carries a high level of electrical 'noise'. It should be segregated from all signal circuits, and should include a ground conductor linking the drive ground directly to the motor frame.
2. The mains supply wiring also carries electrical noise and should be segregated from signal circuits.
3. The drive also generates a noise field so sensitive circuits should not be passed close to it.
4. "Noise" current flows in power wiring and returns through the ground (earth). To minimise noise loop areas, ground wires should be run as close as possible to their associated power wires.
5. The drive ground tends to be 'noisy', so it is preferable for the control circuits to be grounded only at the controller and not at the drive.

4.5.2 Full EMC precautions

Figure 4.7 shows the requirements which be followed closely in order to meet EMC emission standards. Further guidance and information on EMC standards is given in the EMC Data sheets which are available from Control Techniques' Drive Centres or Distributors.

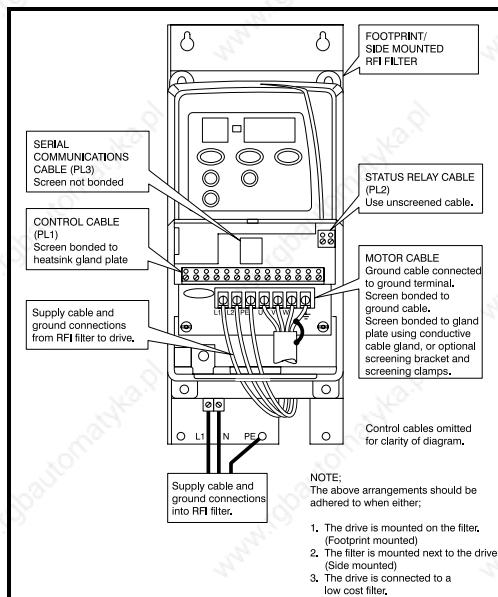


Figure 4.12 Full EMC precautions

NOTE

The above guidelines are applicable to all drive sizes.

For further information on the cable screening brackets and screening clamps kit, refer to the *Commander SE Advanced User Guide* and the EMC Data sheets which are

available from Control Techniques' Drive Centres and Distributors.

4.5.3 Special requirements

Special considerations are required for the following requirements:

Meeting the residential emission standard, EN50081-1 (Size 1 only)

One of the footprint filters (part number 4200-6102 or 4200-6103) must be used.

Interruptions to the motor cable

The motor cable should ideally be a single run of shielded cable having no interruptions. In some situations it may be necessary to interrupt the cable, for example to connect the motor cable to a terminal block within the drive enclosure, or to fit an isolator switch to allow safe working on the motor. In these cases both motor cable shield connections must be clamped directly to the back-plate or other flat metallic structure, as illustrated in figures 4.13 and 4.14. Keep the length of unshielded power conductors to a minimum, keep them as close as possible to the metal plate, and ensure that all sensitive equipment and circuits are at least 0.3m (12in) away from them.

Terminal block within enclosure

Refer to Figure 4.13.

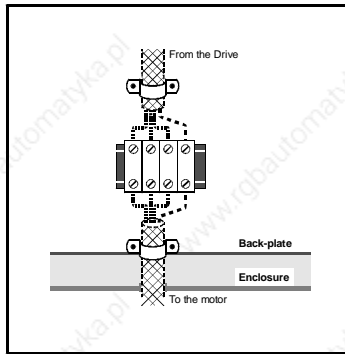


Figure 4.13 Connecting the motor cable to a terminal block in the enclosure.

Using a motor isolator switch

Refer to Figure 4.14.

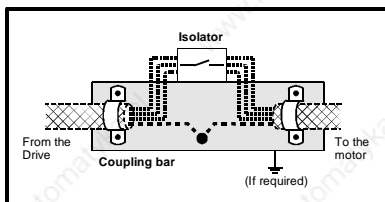


Figure 4.14 Connecting the motor cable to an isolating switch.

4.5.4 RFI filter recommendations and data.

Use one RFI filter for each drive. Filters of appropriate current rating may be shared between drives, but small deviations from the stated standards may then occur.

The filter performance depends upon the motor cable length and switching frequency. The filter performance for the maximum motor cable length for residential and industrial standards is shown in Table 4.4 to Table 4.13. For further details on filter performance with shorter cable lengths, see the EMC Data sheets which are available from Control Techniques' Drive Centres or Distributors.



High ground leakage current

Most RFI filters have ground leakage current exceeding 3.5mA. All equipment using these filters must be provided with a permanent fixed ground connection.

Special low-leakage filters are provided for applications where a permanent ground connection is not practical.

Commander SE Size 1

Motor cable length m	Filter and Switching Frequency								
	Standard (4200-6102)			Low Cost (4200-6101)			Low Leakage (4200-6103)		
	3kHz	6kHz	12kHz	3kHz	6kHz	12kHz	3kHz	6kHz	12kHz
5	R	R	R	R	R		R		#
15	R	R		R	R			#	#
20	R	R		R	R				
50	R								
75		#	#						

Table 4.4 Commander SE Size 1

Commander SE Size 2

Motor cable length m	Filter and Switching Frequency								
	Standard (4200-6201)			Low Cost (4200-6204)			Low Leakage (4200-6205)		
	3kHz	6kHz	12kHz	3kHz	6kHz	12kHz	3kHz	6kHz	12kHz
15	R	R	R						#
50	R	R			#	#			
80	R	R							
100									

Table 4.5 Drive Range: SE2D200075 to SE2D200220, single phase

Motor cable length m	Filter and Switching Frequency								
	Standard (4200-6202)			Low Cost (4200-6304)			Low Leakage (4200-6207)		
	3kHz	6kHz	12kHz	3kHz	6kHz	12kHz	3kHz	6kHz	12kHz
15	R	R	R		#	#			#
45	R	R	R					#	#
100	R	R							

Table 4.6 Drive Range: SE2D200075 to SE2D200220, three phase

Motor cable length m	Filter and Switching Frequency								
	Standard (4200-6202)			Low Cost (4200-6304)			Low Leakage (4200-6207)		
	3kHz	6kHz	12kHz	3kHz	6kHz	12kHz	3kHz	6kHz	12kHz
15	R	R			#	#		#	#
20	R	R						#	#
50	R								
100		#	#						

Table 4.7 Drive Range: SE23400075 to SE23400400, three phase

Motor cable length m	Filter and Switching Frequency								
	Standard (4200-6203)			Low Cost (4200-6303)			Low Leakage (4200-6209)		
	3kHz	6kHz	12kHz	3kHz	6kHz	12kHz	3kHz	6kHz	12kHz
20	R	R						#	#
45								#	#
100		#	#						

Table 4.8 Drive Range: SE23200400, three phase

Commander SE Size 3

Motor cable length m	Filter and Switching Frequency					
	Standard (4200-6302)			Low Cost (4200-6303)		
	3kHz	6kHz	12kHz	3kHz	6kHz	12kHz
15	R					#
20	R					
100		#	#			

Table 4.9 Drive Range: SE33200550 to SE33200750

Motor cable length m	Filter and Switching Frequency					
	Standard (4200-6301)			Low Cost (4200-6304)		
	3kHz	6kHz	12kHz	3kHz	6kHz	12kHz
15	R	R				
30	R					
100		#	#			

Table 4.10 Drive Range: SE33400550 to SE33400750

Commander SE Size 4, 11-15kW

Motor cable length m	Filter and Switching Frequency					
	Standard (4200-6401)			Low Cost (4200-6402)		
	3kHz	6kHz	12kHz	3kHz	6kHz	12kHz
15	R				#	#
20	R					
100		#	#			

Table 4.11 Drive Range: SE43401100 to SE43401850

Commander SE Size 4, 18.5kW

Motor cable length m	Filter and Switching Frequency					
	Standard (4200-6403)			Low Cost (4200-6404)		
	3kHz	6kHz	12kHz	3kHz	6kHz	12kHz
20	R	R	R		#	#
70						
100			#			

Table 4.12 Drive Range: SE43401850

Commander SE Size 5

Motor cable length m	Filter and Switching Frequency								
	4200-6116*			4200-6117**			4200-6106***		
	3kHz	6kHz	12kHz	3kHz	6kHz	12kHz	3kHz	6kHz	12kHz
10	R	R	I	R	R	I	R	R	I
50	I	#	#	I	#	#	I	#	#
100	I	#	#	I	#	#	I	#	#

Table 4.13 Drive range SE53402200 ~ SE53403700

* Filter used on drive range SE53402200

** Filter used on SE53403000

*** Filter used on SE53403700

Key:

R EN50081-1 Conducted emission requirements of the generic emission standard for the residential, commercial and light industrial environment.

I EN50081-2 Conducted emission requirements of the generic emission standard for the industrial environment.

Special techniques required e.g. output filters. Contact your Local Control Techniques Drive Centre.

Further data for the filters is given in the following tables:

Part Number	Maximum Power Losses W	IP Rating	Weight kg	Operational Leakage Current mA	Worst Case Leakage Current mA	Terminal Torques Nm / lb ft
4200-6101	6	21	0.49	4.0	8.0	0.8 / 0.6
4200-6102	6	20	0.60	40.7	77.5	0.8 / 0.6
4200-6103	6	21	0.60	2.9	5.7	0.8 / 0.6

Table 4.14 Commander SE Size 1

Part Number	Maximum Power Losses W	IP Rating	Weight kg	Operational Leakage Current mA	Worst Case Leakage Current mA	Terminal Torques Nm / lb ft
4200-6201	10.1	20	1.2	89	128	0.8 / 0.6
4200-6202	10.1	20	1.1	45.7	184.2	0.8 / 0.6
4200-6203	15.4	20	1.3	26.4	106.3	0.8 / 0.6
4200-6204	6	20	0.7	29.5	58.9	0.8 / 0.6
4200-6205	10.1	20	1.2	2.8	5.7	0.8 / 0.6
4200-6207	10.1	20	1.1	3	18.3	0.8 / 0.6
4200-6209	15.4	20	1.3	2.6	15.5	0.8 / 0.6

Table 4.15 Commander SE Size 2

Part Number	Maximum Power Losses W	IP Rating	Weight kg	Operational Leakage Current mA	Worst Case Leakage Current mA	Terminal Torques Nm / lb ft
4200-6301	12.4	20	1.6	45.7	184.2	0.8 / 0.6
4200-6302	19.5	20	1.7	26.4	106.3	0.8 / 0.6
4200-6303*	10.8	20	0.8	14.1	68	0.8 / 0.6
4200-6304*	6.1	20	0.6	33	148	0.8 / 0.6

Table 4.16 Commander SE Size 3

*Also used on Size 2 units.

Part Number	Maximum Power Losses W	IP Rating	Weight kg	Operational Leakage Current mA	Worst Case Leakage Current mA	Terminal Torques Nm / lb ft
4200-6401	26.1	20	3.1	29.4	280	2.2 / 1.6
4200-6402	11.7	20	1.1	14.1	68	2.2 / 1.6
4200-6403	30	20	3.1	38	220	2.2 / 1.6
4200-6404	16	20	1.2	24.5	132	2.2 / 1.6

Table 4.17 Commander SE Size 4

Part Number	Maximum Power Losses W	IP Rating	Weight kg / lb	Operational Leakage Current mA	Worst Case Leakage Current mA	Terminal Torques Nm / lb ft	Ground connection torque Nm / lb ft
4200-6116	12.8	20	3.8 / 9	31	143	4.5 / 3.3	2.2 / 1.6
4200-6117	14.3	20	3.8 / 9	29	126	4.5 / 3.3	4.0 / 2.9
4200-6106	25.5	20	7.8 / 17	48.5	209	8.0 / 5.9	9.0 / 6.6

Table 4.18 Commander SE Size 5

Discharge resistors

1.5M Ω in a star connection between phases with star point connected by a 680k Ω resistor to ground.

NOTE *This may cause an earth leakage indication in monitored ungrounded power systems such as IT systems.*

NOTE *For tables 4.13 to 4.17, please be aware of the following:*

Weight is unpacked weight.

Worst case leakage current:

Single phase filters - when the neutral is disconnected.

Three phase filters - when an input phase is disconnected.

The data is given for an input voltage of 230V, 50Hz.

5 Terminals

5.1 Power terminal connections

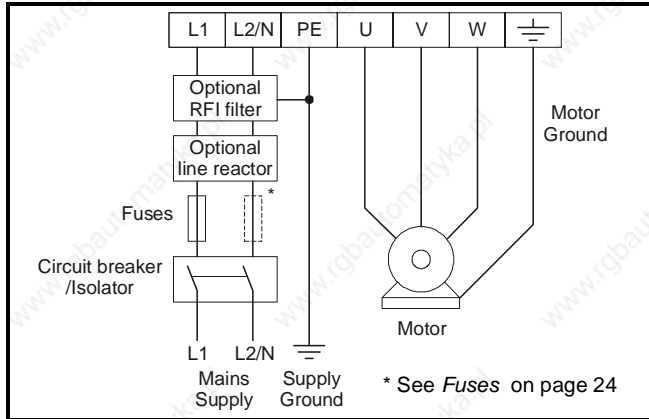


Figure 5.1 Commander SE Size 1 power terminal connections

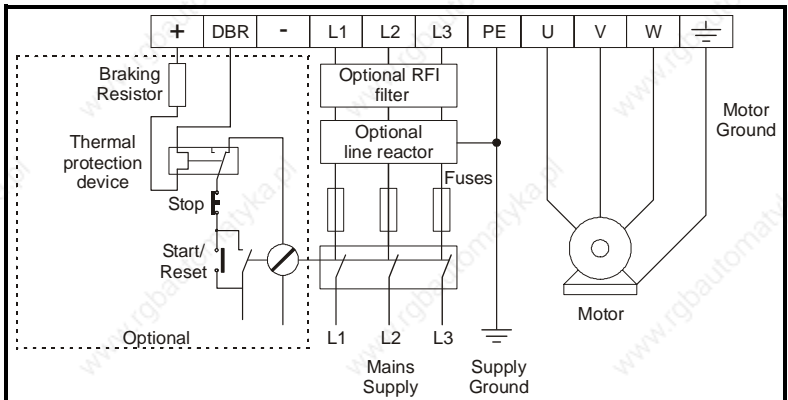


Figure 5.2 Commander SE Size 2 to 4 power terminal connections

NOTE

When a Commander SE Size 2 200V unit is used on single phase, use terminals L1 and L2.

Drive Size	Maximum Power Terminal Screw Torque
1 & 2	1Nm (9lb in)
3 & 4	2Nm (18lb in)
5	15Nm (11lb ft)

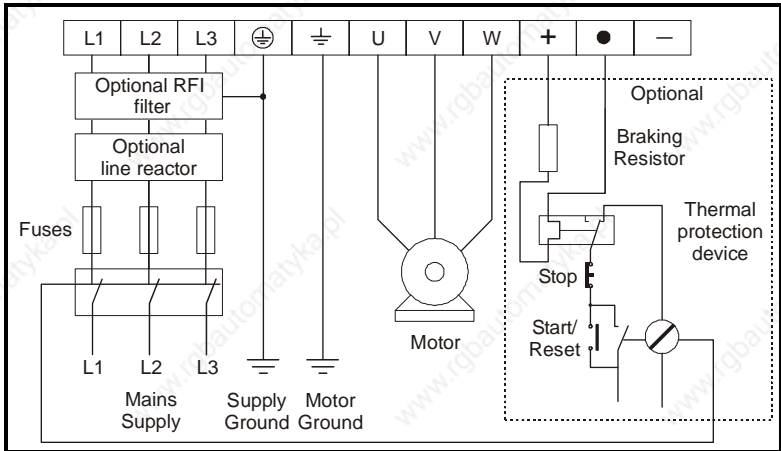


Figure 5.3 Commander SE Size 5 power terminal connections

5.1.1 Thermal protection for an optional braking resistor



Figure 5.2 shows a typical circuit arrangement for braking resistor protection. This thermal protection must disconnect the AC supply from the drive if the resistor becomes overloaded. (Do not use overload opening contact in line with braking resistor).

For further information on braking and braking resistor sizing, refer to the *Commander SE Advanced User Guide*.

5.2 Control terminal connections

The terminal connections are shown in Figure 5.4. As default - in positive logic. Maximum control terminal screw torque: 0.6 Nm (5.5 lb in)

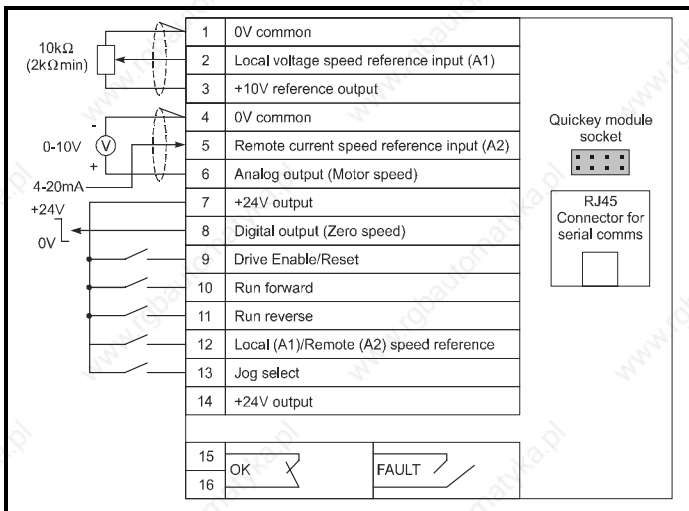


Figure 5.4 Control terminal connections

NOTE

The connection arrangement shown here illustrates how the terminals are intended to be used. Screening of the analog signal wires is not essential, but reduces the risk of electrical noise causing disturbance to the signals.

Where full EMC precautions are required, the guidelines in section 4.5.2 must also be followed to ensure compliance with radio frequency emission limits. This requires the use of one or more screened cables for all wiring to terminals 1 to 14, with the screen bonded to the gland plate (ground). This results in the 0V common terminal being connected to ground through the cable screen.

Where it is required to keep 0V separate from ground, there are two possibilities:

- Use a multi-core cable with overall screen, using one core for the 0V connection. There is a slight risk of electrical noise affecting the analog inputs.
- Use a double screened cable for the analog inputs, with the inner screen connected to 0V and the outer screen to ground.

5.3 Serial communication connections

Serial communication connections can be made via the RJ45 connector (see Figure 5.3).

PIN 2 RXTX

PIN 3 0V

PIN 4 +26V (+10% / -7%) 100mA serial communications

PIN 6 TX Enable

PIN 7 RX\TX\

When using a suitable serial communications converter with Commander SE, it is recommended that no terminating resistors be connected on the network. This applies to any of the drives on the network and also any converter used. It may be necessary to link out the terminating resistor within the converter, depending on which type is used. The information on how to link out the terminating resistor will normally be contained in the user information supplied with the converter. Terminating resistors are of little or no value when used on RS485 networks operating at or below 19.2k baud.

For further information, refer to the *Commander SE Advanced User Guide*.



The communications port of the Commander SE drive is double-insulated from the power electronics and single-insulated from the status relay contacts. Providing that the voltage on the status relay contacts does not exceed 110V, the communications port meets the requirements for SELV in EN50178. However, in the event of a serious fault in the drive, the safety barriers could be breached. Therefore when using the communications port with a personal computer or centralised controller e.g. PLC, an isolation device must be included with rated voltage at least equal to the drive supply voltage. Ensure that the correct fuses are installed at the drive input, and that the drive is connected to the correct supply voltage.

5.4 Control terminal specifications



Isolation of control circuits

The control terminals of the Commander SE drive are double-insulated from the power electronics and single-insulated from the status relay contacts. Providing that the voltage on the status relay contacts does not exceed 110V, the control terminals meet the requirements for SELV in EN50178. However, in the event of a serious fault in the drive, the safety barriers could be breached. The installer must ensure that the external control circuits are insulated from human contact by at least one layer of insulation rated for use at the AC supply voltage. If the control circuits are to be connected to other circuits classified as SELV e.g. a personal computer, an additional isolating barrier must be included in order to maintain SELV classification. Ensure that the correct fuses are installed at the drive input, and that the drive is connected to the correct supply voltage.

5.4.1 Default configuration



All outputs (+24V, +10V, Digital output and Analog output) could be permanently damaged if a negative voltage greater than -1V is applied to them.

1	0V common	
2	Local Speed reference input (A1)	
Type of input	Single-ended	
Voltage range	0 to +10V	
Scaling	0V represents the value in parameter 01 , Minimum speed. +10V represents the value in parameter 02 , Maximum speed.	
Absolute maximum voltage range	+35V to -18V with respect to 0V common	
Input impedance	100k Ω	
Resolution	0.1% (10 bit)	
Accuracy	$\pm 2\%$	
Sample time	6ms	
3	+10V reference output	
Voltage accuracy	$\pm 2\%$	
Maximum output current	5mA	
Protection	tolerates continuous short circuit to 0V	
4	0V common	
5	Remote current speed-reference input (A2)	
Default	4 - .20mA (See parameter 16)	
Type of input	Single ended	
Current range (programmable)	0-20mA, 20-0mA, 4-20mA, 20-4mA, 4-.20mA, 20-.4mA	
Absolute maximum voltage range	+30V to -18V with respect to 0V common	
Input impedance	200 Ω	
Resolution	0.1% (10 bit)	
Accuracy	$\pm 2\%$	
Sample time	6ms	

The remote current speed-reference input circuit incorporates a protection circuit to prevent any internal damage within the drive in the event of an external controller fault. This protection circuit senses the input current and if this exceeds 25mA, a FET disconnects the external controller from the drive. This FET will also disconnect the external controller signal when the drive is powered off.

6 Analog voltage output	
Default	Motor Speed (See parameter 36)
Absolute maximum voltage range	+35V to -1V with respect to 0V common
Voltage range	0 to +10V
Scaling: Motor speed output	0V represent 0Hz/0 rpm output +10V represents the value of parameter 02 , Maximum speed.
% Motor load output	$V_{OUT} = \frac{\text{ActiveCurrent}}{1.5 \times \text{DriveRatedCurrent}} \times 10$
Maximum output current	5mA
Resolution	0.1% (10 bit)
Accuracy	± 5%
Update time	22ms
Protection	tolerates continuous short circuit to 0V

7 +24V output	
Voltage accuracy	± 10%
Maximum output current	100mA
Protection	tolerates continuous short circuit to 0V

8 Digital output	
Function	Zero Speed Output
Absolute maximum voltage range	+35V to -1V with respect to 0V common
Voltage range	0V to +24V
Maximum output current	50mA at +24V
Output impedance	10kΩ pull-down resistor in inactive state.
Update time	1.5ms
Operation of digital output	+24V = Zero speed, 0V = Above zero speed

NOTE

The total current available from the +24V rail, which includes the digital output, is 100mA. Therefore if the digital output is providing 30mA, the +24V rail will only provide 70mA.

9 Digital input - Enable / Reset †	
10 Digital input - Run Forward (Edge triggered) *	
11 Digital input - Run Reverse (Edge triggered) *	
12 Digital input - Local/Remote Speed Ref (A1/A2)	
13 Digital input - Jog	
Default	Positive logic (See parameter 34)
Voltage range	0V to +24V
Absolute maximum voltage range	+35V to -18V with respect to 0V common
Nominal threshold voltage	+10V
Input impedance	7.5kΩ
Sample time	1.5ms

If the enable terminal is opened, the drive's output is disabled and the motor will coast to a stop. The drive cannot be re-enabled for 2 seconds following the opening of the enable terminal.

† Following a drive trip, open and close the Enable terminal to reset the drive. If the Run Forward or Run Reverse terminal is closed, the drive will run straight away.

* Following a drive trip and a reset via the Stop/Reset key the Run Forward or Run Reverse terminals will need to be opened and closed to allow the drive to run. This ensures that the drive does not start when the Stop/Reset key is pressed.

14 +24V output	
Voltage accuracy	± 10%
Maximum output current	100mA
Protection	tolerates continuous short circuit to 0V

15 Status relay (Normally open)	
16 Function	Drive Healthy
Voltage rating	240Vac /30Vdc
Current rating	2A/6A (resistive)
Contact isolation	2.5kVac (meets IEC664-1 with over voltage category II)
Update time	6ms
Operation of contact	OPEN - AC supply removed from drive - AC supply applied to drive with the drive in a tripped condition CLOSED - AC supply applied to drive with the drive in a 'ready to run' or 'running' condition (not tripped)



Provide fuse or other over-current protection in status relay circuit.

6 Handling and Programming

6.1 Display and keypad

The display and keypad are used for the following:

- Displaying the operating status of the drive
- Displaying fault or trip codes
- Reading and changing parameter values
- Stopping, starting and resetting the drive

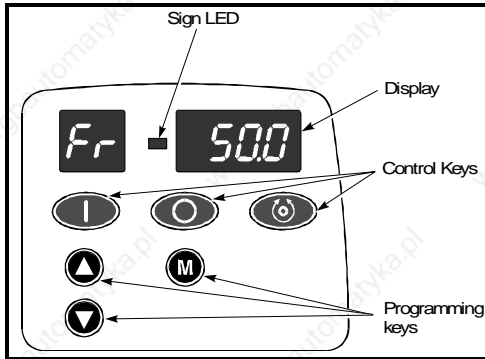


Figure 6.1 Display and Keypad (as seen when the AC supply is connected to the drive)

6.1.1 Programming keys

The **M** **MODE** key is used to change the mode of operation of the display.

If the **MODE** key is pressed and then released within 2 seconds, the display will change from Status Mode to Parameter View Mode.

If the **MODE** key is pressed and held down for 2 seconds then the Status Mode will change from speed indication to load indication and vice versa. See Parameters 22 and 23.

The drive will remember the displayed units on power down (speed or load) such that the same units are presented on the next power up.

The **▲** **INCREASE** & **▼** **DECREASE** keys are used to select parameters and edit their values. Also, in keypad mode, they are used to increase and decrease the speed of the motor.

6.1.2 Control keys

The **▶** **RUN** key is used in keypad mode, to **START** the drive.

The **⏻** **STOP/RESET** key is used in keypad mode, to **STOP** and **RESET** the drive. It can also reset the drive in terminal control.

The **↻** **FORWARD/REVERSE** key is used in keypad mode to change direction of rotation of the motor (when parameter 26=On).

6.2 Display Messages

6.2.1 Status mode

In status mode, left hand display indicates a two letter mnemonic indicating the status of the drive:

Display	Status	Explanation
rd	Drive ready	The drive is enabled and ready for a start command. The output bridge is inactive.
ih	Drive inhibited	The output bridge is inactive because the drive is disabled, or a coast to stop is in progress, or the drive is inhibited during a trip reset.
tr	Drive has tripped	The drive has received a trip signal. (The trip code will be displayed in the right hand display).
dC	DC injection braking	DC injection braking current is being applied to the motor.

Load indications - see parameter 22

Display mnemonic	Explanation
Ld	Active current as a % of motor rated active current
A	Drive output current per phase in A

Speed indications - see parameter 23

Display mnemonic	Explanation
Fr	Drive output frequency in Hz
SP	Motor speed in rpm
Cd	Machine speed in Customer defined units

NOTE

The frequency or speed on the display is the post ramp reference. It does not include slip compensation, if applied.

6.2.2 Parameter View Mode

In parameter view mode, the left hand display flashes a parameter number. The right hand display shows the value of that parameter.

6.2.3 Parameter Edit Mode

In parameter edit mode, the right hand display flashes the value of the parameter number which is being shown in the left hand display.

The following diagram and procedure shows how to select and then edit parameters:

6.3 Selecting and changing parameters

NOTE

This procedure is written from the first power up of the drive and assumes no terminals have been connected, no parameters have been changed and no security has been set.

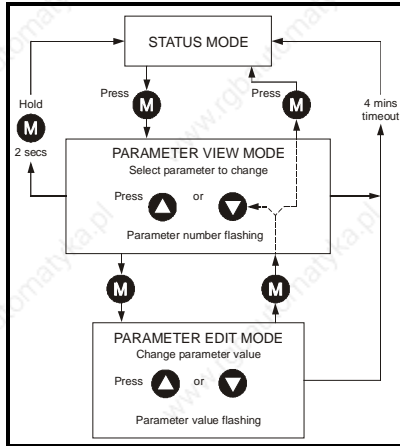


Figure 6.2 Selecting and changing parameters

6.4 Saving parameters

Parameters are automatically saved when the mode button is pressed when going from parameter edit mode to parameter view mode.

6.5 Security codes

A security code is locked into the drive when parameter 25 is set to any value other than 0 and then **Loc** is selected in parameter 10 and the STOP/RESET key pressed.

Once a security code has been locked, parameter 10 will automatically reset to **L1**. Now view only access to parameters 1 to 9 is available.

Parameter 10 may be changed by the user to L2 to allow view only access to all the parameters (1 to 54). In this case, parameter 25 will indicate a value of 0 so as not to reveal the programmed security code.

6.6 Setting a security code

1. Set parameter 10 to L2 to allow access to parameter 25.

2. Set parameter 25 to a security code e.g. 5.

This code changes to 0 once the MODE key is pressed. The display should show:

3. Set parameter 10 to **Loc** and then press the STOP/RESET key to initiate the security code

4. Parameter 10 will automatically reset to L1

5. Security will also be set if the drive is powered down after a code has been set into parameter 25.



6.7 Unlocking a security code

1. Select a parameter to be edited

01 0.0

2. Press the MODE key. The right hand display will flash CodE

01 CodE

3. Press the  or  keys to set the security code. The left hand display will show Co

Co 5

4. Press the MODE key.

5. If the security code has been entered correctly then the display will show

01 0.0

Parameters can now be adjusted

6. If the security code has been entered incorrectly then the display will go back to Parameter View mode

01 0.0

7. Go back to point 2 and enter the correct security code.

8. To relock the security code, set parameter 10 to Loc and press the STOP/RESET key.

10 Loc

6.8 Set security back to zero (0) - no security

1. Unlock the previously entered security code using the previous procedure.
2. Set parameter 10 to L2.
3. Go to parameter 25
4. Press mode key 4 times. This saves the security code to the value 0
5. Set parameter 10 to Loc and press the STOP/RESET key.

NOTE

If the security code has been lost or forgotten, please contact your local drive Centre or Distributor.

6.9 Setting to default values

To set the drive back to default values; set parameter **29** to **Eur** to load 50Hz defaults, **USA** to load 60Hz defaults, **br.Eu** to load 50Hz defaults with brake set up, or **br.US** to load 60Hz defaults with brake set up. Press the MODE key and then the STOP/RESET key for 1 second. When the default parameters have been set, the display will show the status of the drive and the parameter number will return to 01.

6.10 Level 1 and level 2 parameter descriptions

6.10.1 Parameter codes/limitations

The key to the parameter codes/limitations in the following Tables is listed below:

- | | | |
|---|------------|---|
| 1 | RW | <u>R</u> ead/ <u>W</u> rite |
| 2 | RO | <u>R</u> ead <u>O</u> nly |
| 3 | Bit | Two state only parameter, OFF or ON |
| 4 | B | <u>B</u> ipolar - can have positive or negative values |
| 5 | U | <u>U</u> nipolar - can have positive values only |
| 6 | T | Parameter value is represented on the display with a string of <u>T</u> ext |
| 7 | R | <u>R</u> eset required to implement change |
| 8 | S | <u>S</u> aved on power down |

6.10.2 Level 1 parameters

NOTE

Text after a block of parameters refers to the preceding parameter(s).

No.	Function	Type	Limitations	Range	Units	Defaults
01	Minimum speed	RW	U	0 - parameter 02	Hz	0.0 EUR 0.0 USA

Used to set minimum speed at which the motor will run.

(0V reference or minimum scale current input [see parameter 16] represents the value in parameter 01).

No.	Function	Type	Limitations	Range	Units	Defaults
02	Maximum speed	RW	U	0 - 1000	Hz	50.0 EUR 60.0 USA

Sets the maximum speed at which the motor will run in both directions of rotation. If parameter 02 is set below parameter 01, parameter 01 is automatically set to the new value of parameter 02. (+10V reference or full scale current input [see parameter 16] represents the value in parameter 02).

NOTE

The output speed of the drive can exceed the value set in parameter 02 due to slip compensation and current limits.

No.	Function	Type	Limitations	Range	Units	Defaults
03	Acceleration rate	RW	U	0.0-3200.0	s/100Hz	5.0 EUR 5.0 USA
04	Deceleration rate	RW	U	0.0-3200.0	s/100Hz	10.0 EUR 10.0 USA

Sets the acceleration and deceleration rate of the motor for both directions of rotation.

The acceleration rate corresponds to the time to accelerate from 0 to 100Hz. Therefore, with a programmed ramp time of 5 seconds, the ramp output will reach 50Hz from 0Hz in 2.5 seconds.

The deceleration rate corresponds to the time to decelerate from 100 to 0Hz.

Therefore, with a programmed ramp time of 10 seconds, the ramp output will reach 0Hz from 50Hz in 5 seconds.

NOTE

The deceleration rate could be extended by the drive to prevent over voltage (OU) trips if the load inertia is too high for the programmed deceleration rate, if one of the standard ramp modes is selected - parameter 30.

NOTE

Although the acceleration and deceleration rates can be set to 0.0, there is a minimum ramp rate within the software of 0.1s/100Hz.

No.	Function	Type	Limitations	Range	Units	Defaults
05	Speed reference select	RW	T	A1.A2,A1.Pr, A2.Pr,Pr,PAd		A1.A2 EUR PAAd USA

The setting of parameter 05 will select the type of speed reference input and also the function of the digital inputs on terminal 12 and 13.

Parameter 05 settings:

- **A1.A2** - Analog voltage input on terminal 2 and analog current input on terminal 5 selected by terminal 12. Jog selected by terminal 13
- **A1.Pr** - Analog voltage input on terminal 2 and 3 preset speeds selected by terminals 12 and 13
- **A2.Pr** - Analog current input on terminal 5 and 3 preset speeds selected by terminals 12 and 13
- **Pr** - 4 Preset speeds selected by terminals 12 and 13
- **PAAd** - keypad control

NOTE

PAd - Keypad reference selected. Terminals 10, 11, 12 and 13 do not have any function in this mode.

The settings for parameter 05 are explained fully on the following pages.

Parameter 5 set to A1.A2

Local voltage (A1) or remote current (A2) speed reference inputs

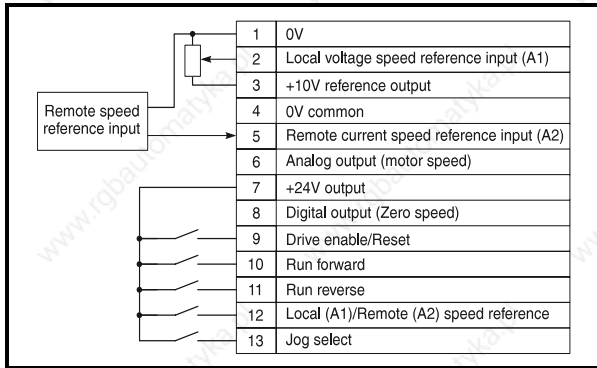


Figure 6.3 Terminal connections

Input Source	Terminal 12	Terminal 13	Enable	Run Forward	Run Reverse	Motor Action
A1	open	open	closed	closed	open	Run Forward
A1	open	open	closed	open	closed	Run Reverse
A2	closed	open	closed	closed	open	Run Forward
A2	closed	open	closed	open	closed	Run Reverse

NOTE

If the Run Forward and Run Reverse terminals are both closed, the drive will stop under the selected ramp and stopping modes.

Jog speed reference (parameter 15)

Terminal 12	Terminal 13	Enable	Run Forward	Run Reverse	Motor Action
open or closed	closed	closed	closed	open	Jog Forward
open or closed	closed	closed	open	closed	Jog Reverse

NOTE

If jog speed is selected during normal running, the motor will accelerate or decelerate to the jog speed at the normal acceleration ramp (parameter 03) or deceleration ramp (parameter 04) and then the jog acceleration and deceleration ramps (0.2 seconds) will be selected. Once jog has been selected use the Run Forward or Run Reverse terminals to jog.

Parameter 5 set to A1.Pr

Local voltage (A1) speed reference input with 3 preset speeds

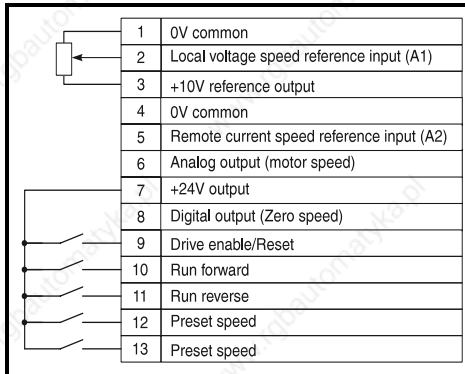


Figure 6.4 Terminal connections

Close terminals 12 and 13 as in the following table to select the desired preset speed.

Terminal 12	Terminal 13	Enable	Run Forward	Speed reference
open	open	closed	closed	Local speed ref. (A1)
closed	open	closed	closed	Preset speed 2 (parameter 12)
open	closed	closed	closed	Preset speed 3 (parameter 13)
closed	closed	closed	closed	Preset speed 4 (parameter 14)

NOTE

If Enable negative preset speeds (parameter 17) is set, then a negative preset speed will cause the motor to run in the reverse direction. Alternatively, closing terminal 11 (Run Reverse) instead of terminal 10 will change the sign of the selected speed such that a positive preset speed will become negative for reverse rotation.

Parameter 5 set to A2.Pr

Remote current (A2) speed reference input with 3 preset speeds.

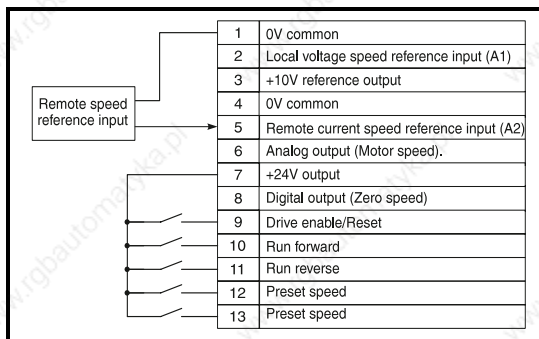


Figure 6.5 Terminal connections

Close terminals 12 and 13 as in the following table to select the desired preset speed:

Terminal 12	Terminal 13	Enable	Run Forward	Reference
open	open	closed	closed	Remote speed ref. (A2)
closed	open	closed	closed	Preset speed 2 (parameter 12)
open	closed	closed	closed	Preset speed 3 (parameter 13)
closed	closed	closed	closed	Preset speed 4 (parameter 14)

NOTE

If Enable negative preset speeds (parameter 17) is set, then a negative preset speed will cause the motor to run in the reverse direction. Alternatively, closing terminal 11 (Run Reverse) instead of terminal 10 will change the sign of the selected speed such that a positive preset speed will become negative for reverse rotation.

Parameter 5 set to Pr

4 Preset speeds

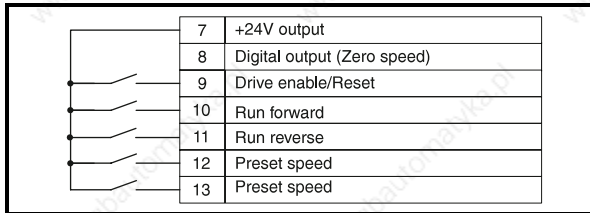


Figure 6.6 Terminal connections

Close terminals 12 and 13 as in the following table to select the desired preset speed.

Terminal 12	Terminal 13	Enable	Run Forward	Speed Reference
open	open	closed	closed	Preset speed 1 (Parameter 11)
closed	open	closed	closed	Preset speed 2 (Parameter 12)
open	closed	closed	closed	Preset speed 3 (Parameter 13)
closed	closed	closed	closed	Preset speed 4 (Parameter 14)

NOTE

If Enable negative preset speeds (parameter 17) is set, then a negative preset speed will cause the motor to run in the reverse direction. Alternatively, closing terminal 11 (Run Reverse) instead of terminal 10 will change the sign of the selected speed such that a positive preset speed will become negative for reverse rotation.

Parameter 5 Set to PAD

Keypad control

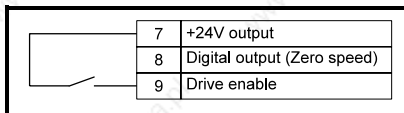





Figure 6.7 Keypad connections

-  Used to start the drive.
-  Used to stop the drive. Also used to reset the drive after a trip.
After a reset command, the drive will need a start command to run.
-  Used to reverse the direction of rotation of the motor
(when parameter 26 = On).

No.	Function	Type	Limitations	Range	Units	Defaults
06	Motor rated current	RW	U	0 - Drive rated current	A	Drive rating Drive rating EUR USA

Enter the motor current rating (taken from the motor name plate).
The drive rated current value is the 100% RMS output current value of the drive. This value can set to a lower value but not a higher value.

No.	Function	Type	Limitations	Range	Units	Defaults
07	Motor rated speed	RW	U	0 - 9999	rpm	1500 1800 EUR USA

Enter the rated full load speed of the motor (taken from the motor name plate).
The rated speed is used to calculate the correct slip for the motor.
The rated speed is the synchronous speed - the 100% full load slip of the motor.

Example: For a 4 pole motor with a synchronous speed of 1500rpm and a slip speed of 70rpm, enter 1430rpm in parameter 07.

NOTE *A value of zero entered into parameter 07 means slip compensation is disabled.*

NOTE *If the full load speed of the motor is above 9999rpm, enter a value of 0 in parameter 07. This will disable slip compensation as values greater than 9999 cannot be entered into this parameter.*

NOTE *Slip compensation should be disabled when using Commander SE on a high inertia load, e.g. fan.*

No.	Function	Type	Limitations	Range	Units	Defaults
08	Motor rated voltage	RW	U	0 - 240 0 - 480	V	230/400 230/460 EUR USA

Enter the motor rated voltage (taken from the motor name plate).

No.	Function	Type	Limitations	Range	Units	Defaults
09	Motor power factor	RW	U	0 - 1.00		0.85 0.85 EUR USA

The motor power factor $\cos \phi$ (taken from the motor name plate).

No.	Function	Type	Limitations	Range	Units	Defaults
10	Parameter access	RW	T	L1, L2, Loc		L1 L1 EUR USA

L1 - Level 1 access - Only parameters 1 to 10 can be selected for viewing or adjusting.
L2 - Level 2 access - All parameters 1 to 54 can be selected for viewing or adjusting.
Loc - Used to lock a security code in the drive. See *section 6.5 Security codes* on page 42.

6.10.3 Level 2 parameters

No.	Function	Type	Limitations	Range	Units	Defaults
11	Preset 1	RW	B	±1000.0	Hz	0.0 0.0 EUR USA

Defines the preset speed 1.

For setting of negative preset speed values, see parameter 17.

No.	Function	Type	Limitations	Range	Units	Defaults
12	Preset 2	RW	B	±1000.0	Hz	0.0 0.0 EUR USA

Defines the preset speed 2.

For setting of negative preset speed values, see parameter 17.

No.	Function	Type	Limitations	Range	Units	Defaults
13	Preset 3	RW	B	±1000.0	Hz	0.0 0.0 EUR USA

Defines the preset speed 3.

For setting of negative preset speed values, see parameter 17.

No.	Function	Type	Limitations	Range	Units	Defaults
14	Preset 4	RW	B	±1000.0	Hz	0.0 0.0 EUR USA

Defines the preset speed 4.

For setting of negative preset speed values, see parameter 17.

No.	Function	Type	Limitations	Range	Units	Defaults
15	Jog reference	RW	U	0 - 400.0	Hz	1.5 1.5 EUR USA

Defines the jog speed.

No.	Function	Type	Limitations	Range	Units	Defaults
16	Current input mode	RW	T	0-20, 20-0 4-20, 20-4 4-.20, 20-.4	mA	4-.20 4-.20 EUR USA

Defines the current input on Analog input reference 2, terminal 5. Definition of the current input mode is given in the following sub-table:

Mode	Description
0 - 20	Current input 0 to 20mA (20mA full scale)
20 - 0	Current input 20mA to 0mA (0mA full scale)
4 - 20	Current input 4mA to 20mA with current loop loss (cL) trip (20mA full scale)
20 - 4	Current input 20mA to 4mA with current loop loss (cL) trip (4mA full scale)
4 - .20	Current input 4mA to 20mA with no current loop loss (cL) trip (20mA full scale)
20 - .4	Current input 20mA to 4mA with no current loop loss (cL) trip (4mA full scale)

In the 4-20mA or 20-4mA ranges with current loop loss (cL) trip, the drive will trip on cL if the input reference is less than 3mA.

NOTE

If 4-20mA or 20-4mA modes are selected and the drive trips on current loop loss (cL), analog reference 1 cannot be selected if the current reference is less than 3mA.

No.	Function	Type	Limitations	Range	Units	Defaults
17	Enable negative preset speeds	RW	Bit	On, OFF		OFF OFF EUR USA

OFF - direction of rotation controlled by the Run Forward and Run Reverse terminals

On - Direction of rotation controlled by the preset speeds value (use the Run Forward terminal).

When negative preset speeds are enabled, a negative value entered in parameters 11, 12, 13 and 14 causes the motor to rotate in the reverse direction. If not enabled, all negative values are treated as zero.

No.	Function	Type	Limitations	Range	Units	Defaults
18	Last trip	RO	T, S			- EUR - USA

Defines the last fault trip of the drive.

No.	Function	Type	Limitations	Range	Units	Defaults
19	Trip before P18	RO	T, S			- EUR - USA

Defines the second to last trip of the drive.

No.	Function	Type	Limitations	Range	Units	Defaults
20	Trip before P19	RO	T, S			- EUR - USA

Defines the third to last trip of the drive.

No.	Function	Type	Limitations	Range	Units	Defaults
21	Trip before P20	RO	T, S			- EUR - USA

Defines the fourth to last trip of the drive

No.	Function	Type	Limitations	Range	Units	Defaults
22	Load display units	RW	T	Ld, A		Ld EUR Ld USA

Ld - Active current as a % of motor rated active current

A - Drive output current per phase in A

No.	Function	Type	Limitations	Range	Units	Defaults
23	Speed display units	RW	T	Fr, SP, Cd		Fr EUR Fr USA

Fr - Drive output frequency in Hz

SP - Motor speed in rpm

Cd - Machine speed in customer defined units

Cd (parameter 23) = Speed (rpm) x parameter 24

NOTE *When parameter 23 is set to SP, the display will show a maximum of 9999 rpm. To show higher speeds than 9999, set parameter 23 to Cd (Customer Defined Units) and set parameter 24 to 0.1 or 0.01.*

Parameter 24 set to 0.1 = rpm / 10. Parameter 24 set to 0.01 = rpm / 100.

NOTE

If the Mode key is pressed and held down for 2 seconds, the display's status mode will change from the speed indication to the load indication and vice versa (see parameters 22 and 23).

No.	Function	Type	Limitations	Range	Units	Defaults
24	Customer defined scaling	RW	U	0 - 99.99		1.00 EUR 1.00 USA

Multiplying factor on motor speed (rpm) to give customer defined units

No.	Function	Type	Limitations	Range	Units	Defaults
25	Security set up	RW	U, S	0 - 9999		0 EUR 0 USA

Used to set up a user security code.

No.	Function	Type	Limitations	Range	Units	Defaults
26	Fwd/Rev key enable	RW	Bit	On, OFF		OFF EUR OFF USA

OFF - Keypad Forward / Reverse key disabled

On - Keypad Forward / Reverse key enabled

No.	Function	Type	Limitations	Range	Units	Defaults
27	Power up keypad ref.	RW	T	0, LAST, PrS1		0 EUR 0 USA

In keypad control, this parameter selects the value of the keypad reference on power-up.

0 keypad reference is zero

LAST keypad reference is last value selected before the drive was powered down.

PrS1 keypad reference is copied from preset speed 1.

In keypad control, to look at the keypad reference with the drive disabled, press the ▲ and ▼ keys together.

In terminal control, to look at the keypad reference, press either the ▲ or ▼ key.

No.	Function	Type	Limitations	Range	Units	Defaults
28	Parameter transfer Quickey	RW	T, R	no, rEAd, Prog, Auto, boot		no EUR no USA

no Do nothing

rEAd When this is set and the user performs a drive reset by pressing the STOP/RESET key while the drive is disabled (ih), tripped (tr) or on stand-by (rd), the Quickey contents will be copied to the drive and parameter 28 reset to no. These parameters are then saved automatically by the drive.

Prog When this is set and the user performs a drive reset by pressing the STOP/RESET key, the Quickey contents will be updated with the current drive EEPROM memory parameter settings. Parameter 28 is also reset to no.

Auto When this is set and the user performs a parameter save by pressing the mode button after adjusting a parameter value, the drives current EEPROM memory parameter settings are saved in the Quickey.

NOTE

Any parameter values that have been changed via serial communications but not stored in the drives EEPROM memory will not be stored in the Quickey.

boot When this is set, it provides exactly the same functionality as Auto but in addition it will overwrite the drives EEPROM memory parameter settings with the Quickey parameter settings when the drive is powered up. These parameters are then automatically saved by the drive. This mode provides a very fast and efficient way of re-programming a number of drives.

When the drive parameters are stored to the Quickey, if the current mode is READ or Prog, it is stored in the Quickey as no. If the current mode is Auto or boot, these are stored as Auto or boot.

NOTE *The Quickey memory contains drive size specific information. If the contents of the Quickey are copied to a drive of a different rating to that previously programmed, the drive will trip with the code C.rtg. This signifies that all of the parameters apart from the drive rating specific parameters have been copied from the Quickey.*

NOTE *The Quickey should only be installed or removed when power to the drive has been switched off.*

No.	Function	Type	Limitations	Range	Units	Defaults
29	Load defaults	RW	T, R	no, Eur, USA, br.Eu, br.US		no EUR no USA

no - defaults are not loaded

Eur - 50Hz default parameters are loaded

USA - 60Hz default parameters are loaded

br.Eu - 50Hz defaults are loaded with brake function

br.US - 60Hz defaults are loaded with brake function

After disabling the drive, set parameter 29 to the desired value, press the Mode key once and then the Stop/Reset key for 1 second. When default parameters have been set, the display will return to parameter 01 and parameter 10 will be reset to L1.

See section *Brake set-up* on page 60 for information on brake function.

NOTE *If the brake function is to be used, parameter 29 should be set accordingly before any parameters are programmed. This is because parameter 29 will set all parameters back to their default values.*

No.	Function	Type	Limitations	Range	Units	Defaults
30	Ramp mode	RW	U	0 - 2		1 EUR 1 USA

0 - Fast ramp selected

The deceleration ramp will fall at the programmed deceleration rate (subject to current limits programmed). If the deceleration ramp is too fast for the load inertia, the drive could trip on overvoltage (OU).

Fast ramp is normally the mode selected when using a braking resistor.

1 - Standard ramp with normal motor voltage

The drive controls the motor voltage according to the motor rated voltage entered in parameter 08. The drive may extend the deceleration ramp to prevent the drive tripping on overvoltage (OU) if the load inertia is too high for the programmed deceleration ramp.

2 - Standard ramp with high motor voltage

The drive allows the motor voltage to increase by a factor of 1.2 times the motor rated voltage entered in parameter 08. This increase in voltage saturates the motor, which

increases the losses and therefore reduces the amount of regenerated energy transferring from the motor to the DC Bus for a given deceleration rate. The drive may extend the deceleration ramp to prevent the drive tripping on overvoltage (OU) if the load inertia is too high for the programmed deceleration ramp.

For a given amount of energy, mode 2 allows faster deceleration than mode 1, providing that the motor can withstand the extra losses.

No.	Function	Type	Limitations	Range	Units	Defaults
31	Stopping mode	RW	U	0 - 3		1 1 EUR USA

0 - Coast to stop

When either the Enable, Run Forward or Run Reverse terminals are opened, the drive output is disabled and the motor coast to stop. The drive cannot be re-enabled for 2 seconds after the Disable/Stop command.

1 - Ramp to stop

The drive ramps down to zero speed under the ramp control selected by parameter 30. The drive waits for 1 second with the output enabled before disabling.

2 - Ramp to stop with 1 second DC injection braking

The drive ramps down to zero speed under the ramp control selected by parameter 30. The drive then injects DC for 1 second before the output is disabled.

3 - DC injection braking with detection of zero speed

The drive injects a low speed current and detects when the motor is at low speed. The drive then injects DC for 1 second.

No.	Function	Type	Limitations	Range	Units	Defaults
32	Variable V / f select	RW	Bit	On, OFF		OFF OFF EUR USA

OFF - fixed linear voltage-to-frequency ratio (constant torque - standard load).

On - voltage-to-frequency ratio dependant on load current (dynamic/variable torque - fan / pump load).

No.	Function	Type	Limitations	Range	Units	Defaults
33	Spinning motor select	RW	U	0 - 3		0 0 EUR USA

0 - Catch a spinning motor software disabled

1 - Catch a spinning motor software enabled, detect positive and negative frequencies

2 - Catch a spinning motor software enabled, detect positive frequencies only

3 - Catch a spinning motor software enabled, detect negative frequencies only

NOTE

If the drive is to be configured into fixed boost mode (see parameter 48) with catch a spinning motor software enabled, an autotune (see parameter 38) must be carried out to measure the motor's stator resistance before a drive is configured in fixed boost mode. If this is not done, the drive may trip on 0V and OI.AC while trying to catch a spinning motor.

No.	Function	Type	Limitations	Range	Units	Defaults
34	Positive logic select	RW	Bit, R	On, OFF		ON ON EUR USA

OFF - negative logic enabled (source). Connect 0V to a digital input to make active.

On - positive logic enabled (sink). Connect +24V to a digital input to make active.

NOTE

A change to this parameter is only implemented if the drive is disabled or tripped and the Stop/Reset key is pressed for 1 second.

The Enable and Run terminals should be open when this parameter is changed.

No.	Function	Type	Limitations	Range	Units	Defaults
35	Start/Stop logic select	RW	U, R	0 - 3		0
						EUR 0 USA

This parameter changes the functions of terminals 9, 10 and 11, which are normally associated with enabling, starting and stopping the drive.

NOTE

A change to this parameter is only implemented if the drive is disabled or tripped and the Stop/Reset key is pressed for 1 second.

Parameter 35	Terminal 9	Terminal 10	Terminal 11	Mode
0	Enable	Run Forward	Run Reverse	Non Latching
1	Not Stop	Run Forward	Run Reverse	Latching
2	Enable	Run	Forward/Reverse	Non Latching
3	Not Stop	Run	Forward/Reverse	Latching

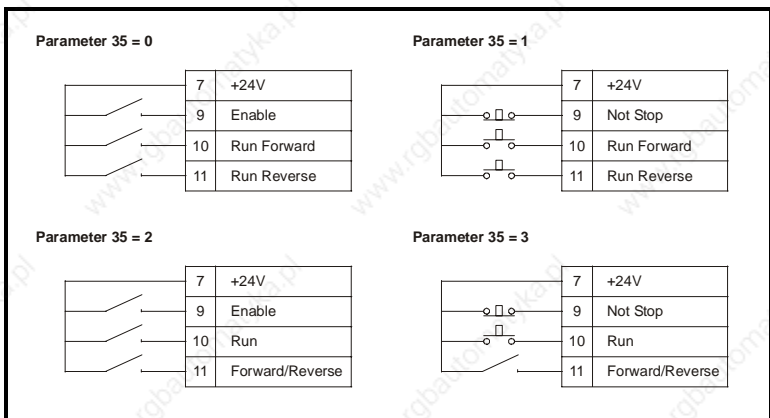


Figure 6.8 Connection details (Positive logic)

No.	Function	Type	Limitations	Range	Units	Defaults
36	Analog output select	RW	T	Fr, Ld, AdV		Fr
						EUR Fr USA

Fr - A voltage proportional to motor speed is produced on terminal 6

Ld - Motor Load Output $V_{OUT} = \frac{\text{ActiveCurrent}}{1.5 \times \text{DriveRatedCurrent}} \times 10$

AdV - An advanced parameter has been programmed to output a signal on terminal 6. See the *Commander SE Advanced User Guide*.

No.	Function	Type	Limitations	Range	Units	Defaults
37	Switching frequency	RW	U	3, 6, 12	kHz	6
						EUR 6 USA

- 3 - 3kHz
- 6 - 6kHz
- 12 - 12kHz

Using Intelligent Thermal Management the drive will automatically reduce the IGBT switching frequency, if set above 3kHz, to try and prevent the drive from tripping on heatsink overtemperature. This will depend on load conditions, heatsink temperature and the operating output frequency of the drive. The following table indicates how the switching frequency is controlled:

Drive Condition	Action
Heatsink >95°C*	Trip drive
Heatsink >92°C	Reduce switching frequency to 3kHz
Heatsink >88°C	Reduce switching frequency to 6kHz
Heatsink <85°C and IGBT temperature at new switching frequency <135°C	Allow an increase in switching frequency
IGBT temperature >135°C	Reduce switching frequency If it is already 3kHz, trip drive

*Commander SE Size 4 >100°C

No.	Function	Type	Limitations	Range	Units	Defaults
38	Autotune	RW	U	0 - 2		0 0 EUR USA

0 - no autotune

1 - non-rotating static autotune

2 - rotating autotune

There are two levels of autotune that can be performed by the Commander SE.

Non-rotating static autotune

This autotune measures the motor stator resistance and system voltage offset. The results of the test are stored in the appropriate parameters. After the test is carried out, the motor will run as requested.

NOTE

The motor must be at standstill before this test is initiated.

Rotating autotune

NOTE

The drive will always carry out a rotating autotune on the motor in the forward direction of motor rotation even if the run reverse command is given to initiate the autotune routine.

In addition to the stator resistance and system voltage offset, the rated magnetising current and total system leakage inductance are measured. The motor is accelerated up to $\frac{2}{3}$ rated speed in the forward direction of motor rotation to measure the rated magnetising current. The speed will be less if insufficient DC Bus voltage is available to operate at $\frac{2}{3}$ rated speed without field weakening. After this autotune has been carried out, the run forward or run reverse terminal will need to be opened and closed to allow the motor to run.

The stator resistance and voltage offset are stored in their appropriate parameters. The rated magnetising current and total system leakage inductance are used to set up the motor rated power factor (parameter 09).

NOTE

The motor must be at standstill and unloaded before this test is initiated.

The main advantage of carrying out a rotating autotune over a non-rotating autotune is that the drive calculates the correct power factor, rated torque current and magnetising current for the motor. This will give more accurate slip compensation (if enabled).

Autotune Procedure

Before a non-rotating static autotune is carried out, the drive's motor map parameters should be correctly set:

Parameter 06 - motor rated current Parameter 08 - motor rated voltage
 Parameter 07 - motor rated speed Parameter 09 - motor power factor

Before a rotating autotune is carried out, additional parameters should be correctly set (this is only true if the motor is not a standard 50/60Hz motor).

Parameter 39 - motor rated frequency Parameter 02 - maximum speed

Although parameter 38 is defaulted to 'no autotune', on the very first power up, Enable and Run command of the drive after delivery from the factory, the drive will initiate a non-rotating static autotune. After this test, the autotune will be dependent on the value set in parameter 38. The results of this test will depend on what is connected to the drive's motor terminals.

NOTE *When default parameters are set (see parameter 29) the first time the drive is given an Enable and Run command, a non-rotating autotune will be initiated.*

No motor connected

With no motor connected, the drive will trip on 'rS' which indicates a stator resistance measurement failure. This will be stored in the drive as zero ohms. The trip can be reset and the drive run as normal. If the drive is powered down and then back up, after an enable and run signal, it will again perform a non-rotating static autotune and trip on 'rS'.

Motor connected but stator resistance higher than allowable value

The drive will again trip on 'rS' if the stator resistance being measured is greater than the drive's internal maximum limit. This can happen if a star connected motor is connected to a 200V Commander SE or a motor of a lower kW rating is connected to a larger kW Commander SE. In this case, the drive will store the maximum allowable stator resistance for that size of drive. If the drive is powered down and then back up, after an enable and run signal, it will not perform another autotune.

Motor connected but current levels required for successful autotune not reached

The drive will trip on 'rS' if the current levels required to measure the stator resistance are not reached in the allowable test time. This will be stored in the drive as zero ohms. This can occur because a combination of stator resistance and motor voltage prevents the required current levels being reached. If the drive is powered down and then back up, after an enable and run signal, it will again perform a non-rotating static autotune. The current levels required for a successful autotune are both half and full motor rated current (parameter 06). Two measurements are taken to ensure accurate results.

Important Notes:

NOTE *It is important to ensure that the motor wiring configuration is correct (i.e. Star / Delta) before performing an autotune.*

NOTE *If any changes are made to the drive's motor map parameters, system wiring, motor wiring configuration or motor type, the drive must be re-autotuned to the motor. Not performing another autotune will result in poor motor performance or OI.AC trips.*

No.	Function	Type	Limitations	Range	Units	Defaults
39	Rated frequency	RW	U	0 - 1000.0	Hz	50.0
						60.0
						EUR USA

Enter the motor rated frequency (taken from motor rating plate).

Defines the voltage to frequency characteristic applied to the motor.

No.	Function	Type	Limitations	Range	Units	Defaults
40	No. of poles	RW	T	Auto, 2P, 4P, 6P, 8P		Auto EUR Auto USA

When Auto is selected, the drive automatically calculates the number of motor poles of the machine from the settings in parameters 07 and 39. If either of these parameters are adjusted for a special motor or to modify the V/f characteristic, the automatic calculation may calculate the number of motor poles incorrectly. This would cause an incorrect slip compensation to be applied and the rpm speed indication would be incorrect. Therefore, the correct number of motor poles should be programmed manually.

No.	Function	Type	Limitations	Range	Units	Defaults
41	Serial mode	RW	T, R	AnSI, rtu, FbUS		AnSI EUR AnSI USA

Used to select the mode of operation of the serial port

AnSI ANSI EIA485 2 wire half duplex serial communications

rtu Modbus RTU protocol

FbUS Fieldbus protocol

NOTE When parameter 41 is set to FbUS, parameter 42 'baud rate', is automatically set to 19.2.

No.	Function	Type	Limitations	Range	Units	Defaults
42	Baud rate	RW	T	2.4, 4.8, 9.6, 19.2		4.8 EUR 4.8 USA

Used to select the comms port baud rate

2.4 2400 baud **9.6** 9600 baud

4.8 4800 baud **19.2** 19200 baud

No.	Function	Type	Limitations	Range	Units	Defaults
43	Serial address	RW	U	0.0 - 24.7		1.1 EUR 1.1 USA

Used to define the unique address for the drive for the serial interface. Any number in the permitted range 0.0 to 24.7 which has a zero in it should not be used as these are used in addressing groups of drives.

No.	Function	Type	Limitations	Range	Units	Defaults
44	Software version	RO	U	1.00 - 99.99		- EUR - USA

Indicates the version of software fitted to the drive.

No.	Function	Type	Limitations	Range	Units	Defaults
45	Fieldbus Node Address	RW	U	0 - 255		0 EUR 0 USA

No.	Function	Type	Limitations	Range	Units	Defaults
46	Fieldbus Baud rate	RW	U	0 - 9		0 EUR 0 USA

No.	Function	Type	Limitations	Range	Units	Defaults
47	Fieldbus Diagnostics	RW	B	-9999 - +9999		0 EUR 0 USA

No.	Function	Type	Limitations	Range	Units	Defaults
48	Voltage mode selector	RW		0 - 3		3 3 EUR USA

- 0 - Open-loop vector mode with static autotune each time the drive is run
- 1 - Open-loop vector mode with no static autotune
- 2 - Fixed boost mode
- 3 - Open-loop vector mode with static autotune the first time the drive is run

This parameter selects the voltage control mode which is used to set the voltage characteristic to be applied to the motor. This falls into two categories:

- Vector mode (parameter 48 set to 0, 1 or 3)
- Fixed boost mode (parameter 48 set to 2)

NOTE

A change to this parameter is only implemented when the drive is disabled or tripped.

Parameter 48 = 0: Open loop vector mode with static autotune

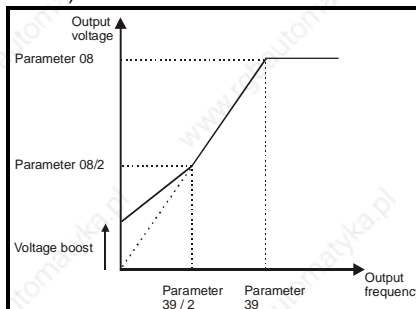
The drive carries out a static autotune to measure the motor's stator resistance and the system voltage offset every time the drive is run. This test can only be done with a stationary motor where the flux has decayed to zero. Therefore this mode should only be used if the motor is guaranteed to be stationary each time the drive is run. To prevent the test from being carried out before the flux has decayed, there is a period of 2 seconds after the drive has been in the 'rd' state during which the test will not be done if the drive is re-started. In this case, previously measured values are used.

Parameter 48 = 1: Open loop vector mode without static autotune

The motor stator resistance and the system voltage offset are not measured. If an autotune is required, set parameter 38 to a 1 (static autotune) or 2 (rotating autotune).

Parameter 48 = 2: Fixed boost mode

The motor stator resistance and the system voltage offset are not used to determine the output voltage characteristic. Instead, the boost voltage (parameter 49) and the motor rated voltage (parameter 08) are used.



This mode should be used in a multiple motor application.

Parameter 48 = 3: Open loop vector mode with static autotune the first time the drive is run

When the default parameters are set or this parameter is set to 3, the drive will carry out a static autotune the first time the drive is run and then this parameter will be set to a 1 automatically.

NOTE

When the drive is received from the factory, this parameter will be set to 3 so that a static autotune will be carried out automatically the first time the drive is run.

If the autotune test is passed, parameter 48 will automatically be set to a 1. If the test

fails, parameter 48 will remain at a 3 so that another autotune will be carried out the next time the drive is run.

No.	Function	Type	Limitations	Range	Units	Defaults
49	Low frequency voltage boost	RW		0 - 25.0	%	3.0 3.0 EUR USA

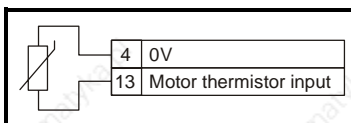
This determines the boost level for the fixed boost characteristic when parameter 48 is set to 2.

No.	Function	Type	Limitations	Range	Units	Defaults
50	Motor thermistor select	RW		On, OFF		OFF OFF EUR USA

OFF - the functionality of terminal 13 is determined by the setting of parameter 05.

ON - terminal 13 is set-up as a motor thermistor input

Connect the motor thermistor between 0V and terminal 13.



Trip resistance: 3k Ω

Reset resistance: 1k Ω

The drive will not trip if the motor thermistor goes short circuit

NOTE *When terminal 13 is set up as a motor thermistor, it is not affected by the logic select (parameter 34).*

NOTE *The following parameters are used for setting up an external mechanical brake.*

NOTE *If the brake function is to be used, parameter 29 should be set accordingly before any parameters are programmed. This is because parameter 29 will set all parameters back to their default values.*

Brake set-up parameters

The following parameters become active when parameter 29 is set to br.EU or br.USA.

No.	Function	Type	Limitations	Range	Units	Defaults
51	Zero speed threshold	RW		0.0 - 20.0	Hz	1.0 1.0 EUR USA

Sets the zero speed threshold

No.	Function	Type	Limitations	Range	Units	Defaults
52	Threshold level	RW		0.0 - 100	%	0.0 0.0 EUR USA

Sets the threshold level for the motor current

No.	Function	Type	Limitations	Range	Units	Defaults
53	Threshold hysteresis	RW		0.0 - 25.0	%	0.0 0.0 EUR USA

Sets the hysteresis level on the motor current

No.	Function	Type	Limitations	Range	Units	Defaults
54	Programmable delay time	RW		0.0 - 25.0	s	0.0 0.0 EUR USA

Sets the logic delay on the digital output

Brake set-up

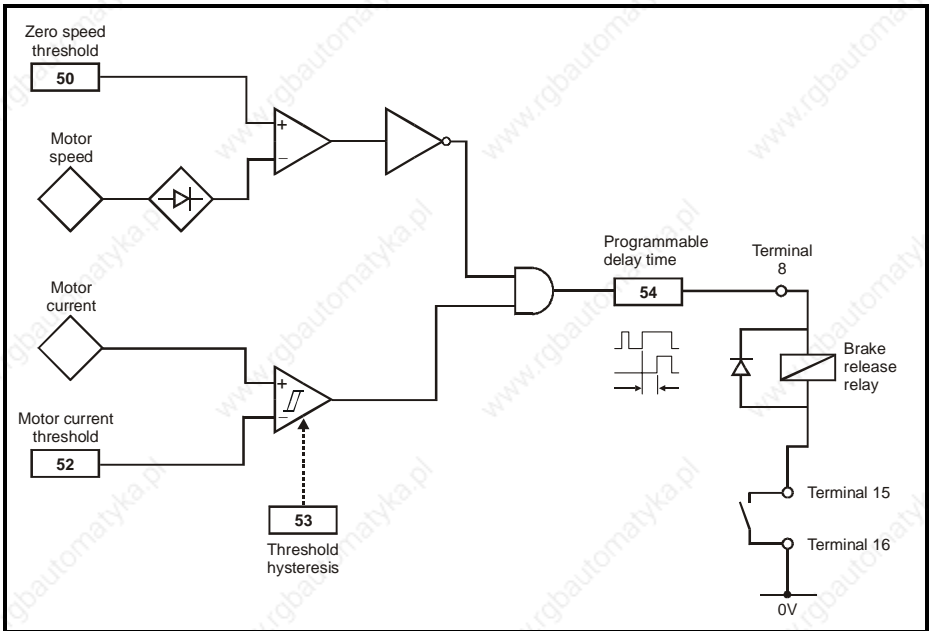


Figure 6.9 Brake set-up logic diagram

Operation

Brake release = Drive Healthy and motor speed above zero speed threshold and motor current above motor current threshold.



The drive healthy relay must be wired in series with the brake release relay so that in the event of a drive trip, the motor brake is engaged.



Great care should be taken when implementing a brake control set-up as this may cause a safety issue depending on the application, e.g. crane. If in any doubt, please contact the supplier of the drive for advice and information

7 Getting Started - Bench Testing

NOTE

The following Getting Started procedures assume that the drive is in its default condition (as supplied) and that no parameters have been changed.

7.1 Terminal control

7.1.1 Basic connections

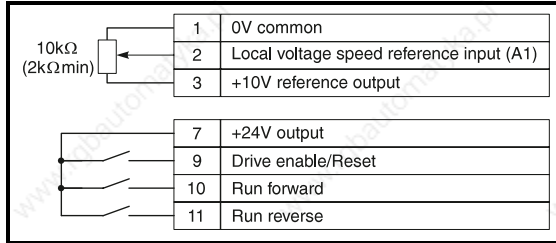


Figure 7.1 Basic connections

1. Connect the drive to the AC supply circuit and motor as described in Chapter 5 *Terminals*.



Observe the safety precautions and ensure the correct fuses or other circuit protection are fitted.

2. Make the signal connections as shown in Figure 7.1
3. Perform the following checks:
 - AC supply and motor connections are correct.
 - Motor installation and motor voltage connections (star/delta) are correct.
 - Motor shaft is not exposed.
 - Terminals 9, 10 and 11 are NOT connected to terminal 7. This ensures that the motor will not start when AC power is applied to the drive.
 - Speed potentiometer is set at minimum.
4. Apply AC power to the drive.
5. Using the **MODE**, **UP** and **DOWN** keys, enter the drive's motor map parameters, **06**, **07**, **08** & **09**. Also parameter **02** *Maximum speed*, parameter **39** *Motor rated frequency* and parameter **40** *Number of motor poles* should be set to the correct value if required. These values should be taken from the motor's rating plate.

NOTE

If the previous parameters are not set correctly then the speed / frequency value on the display may be incorrect.

6. The display should show

ih	0.0
----	-----
7. Close the **ENABLE** contact. The display should show

rd	0.0
----	-----
8. Close the **RUN FORWARD** contact. The display should show

Fr	0.0
----	-----
9. If this is the first time the drive has been run, the drive will perform a non-rotating autotune to measure the stator resistance and voltage offset. *Auto tunE* will flash in

the right hand display during this procedure. Once this has been carried out, the motor will run as requested.

10. Advance the Speed potentiometer. The value in the right hand display should increase accordingly, for example

Fr	25.8
----	------
11. Open the **RUN FORWARD** contact. The display should show a reducing frequency since the drive is decelerating, for example

Fr	10.3
----	------

 and then

rd	0.0
----	-----

Turn the speed potentiometer back to zero.
12. Close the **RUN REVERSE** contact. The display should show

Fr	0.0
----	-----
13. Advance the Speed potentiometer. The value in the right hand display should increase accordingly, for example

Fr	31.4
----	------

The sign LED is lit to show the drive is running reverse.
14. Open the **RUN REVERSE** contact. The display should show, for example

Fr	13.7
----	------

 and then

rd	0.0
----	-----

Turn the potentiometer back to zero.
15. If the drive trips during these tests the display will show, for example

tr	OU
----	----

The right hand display will flash with the trip code.
16. To **RESET** the trip, **OPEN** and then **CLOSE** the **ENABLE** contact or press the Stop/Reset key. The display should show:

rd	0.0
----	-----

NOTE

Following a DRIVE TRIP and a RESET by the STOP/RESET key, the RUN FORWARD or RUN REVERSE terminal will need to be OPENED and CLOSED to allow the drive to run.

NOTE

Following a DRIVE TRIP and a RESET via the DRIVE ENABLE terminal, if the RUN FORWARD or RUN REVERSE terminal is already CLOSED, the drive will run straight away.

NOTE

If this test has been carried out as a bench test and the drive is to be connected to a different motor with different characteristics etc. in the application, then the motor map parameters should be set to the correct values for the new motor and another autotune carried out (see parameter 38 for details).

7.2 Keypad control

7.2.1 Basic connections

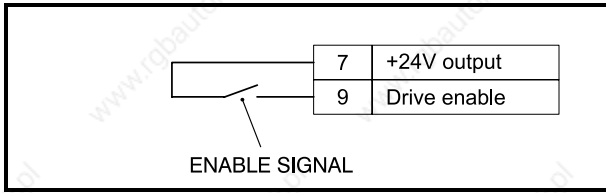


Figure 7.2 Keypad basic connections

1. Connect the drive to the AC supply circuit and motor as described in Chapter 5, *Terminals*



Observe the safety precautions and ensure the correct fuses or other circuit protection are fitted.

2. Make the signal connections as shown in Figure 7.2.
3. Perform the following checks:
 - AC supply and motor connections are correct.
 - Motor installation and motor voltage connections (star/delta) are correct.
 - Motor shaft is not exposed.
4. Apply AC power to the drive.
5. Using the **MODE**, **UP** and **DOWN** keys, enter the drives' motor map parameters, **06**, **07**, **08** & **09**. Also parameter **02** *Maximum Speed*, parameter **39** *Motor rated frequency* and parameter **40** *Number of motor poles* should be set to the correct value if required. These values should be taken from the motors rating plate.


NOTE


If the above parameters are not set correctly then the speed / frequency value on the display may be incorrect.


7.2.2 Setting keypad control

Set parameter **05** to PAD.

7.2.3 Using keypad control

1. Press the  **RUN** key to **START** the drive. The display should show:

Fr	0.0
----	-----
2. If this is the first time the drive has been run, the drive will perform a non-rotating autotune to measure the stator resistance and voltage offset. *Auto tunE* will flash in the right hand display during this procedure. Once this has been carried out, the motor will run as requested.
 - Press the  key to increase the motor speed. The display should show, for example:

Fr	10.0
----	------
 - Press the  key to decrease the drives speed. The display should show, for example:

Fr	5.0
----	-----




- Press the  **STOP** key to **STOP** the drive. The display should show:



3. If the drive trips during these tests the display will show, for example



The right hand display will flash with the trip code

4. Press the  **RESET** button to reset the trip. Press the  **RUN** button to run the drive.
5. The  **FORWARD/REVERSE** button can be enabled by setting parameter **26 = On**.

NOTE

If this test has been carried out as a bench test and the drive is to be connected to a different motor with different characteristics etc. in the application, then the motor map parameters should be set to the correct values for the new motor and another autotune carried out (see parameter 38 for details).

8 Diagnostics and Protective Features



Do not attempt to carry out internal repairs. Return a faulty drive to the supplier for repair.

The following protective features are incorporated within the Commander SE drive. They are placed in order of Trip number which is the figure that is read back through the serial comms.

8.1 Trip codes

When a trip condition occurs, the left hand display will show the legend tr whilst the right hand display flashes one of the trip codes given in Table 8.1.

Trip Code	Trip Number	Condition	Possible Cause
UU	1	DC link under voltage	Low AC supply voltage Low DC link voltage when supplied by external DC power supply
OU	2	DC link over voltage	Excessive inertia in the machine during deceleration Deceleration rate set too fast for inertia of machine
OI.AC**	3	AC instantaneous over current trip	Insufficient ramp times Phase to phase or phase to earth short-circuit at the drive output Drive requires autotuning to motor Motor or motor connections changed, re-autotune drive to motor (see parameter 38)
OI.br**	4	Overcurrent on braking IGBT	Excessive current in braking resistor Braking resistor value too small (Does not apply to Size 1 units)
Et	6	External trip	External trip terminal opened (when programmed)
O.SP	7	Over speed	Excessive motor speed (typically caused by the mechanical load driving the motor)
tunE	18	Auto-tune failure	Motor loaded or no motor connected
It.br	19	Ixt on braking resistor	Excessive braking resistor energy (Does not apply to Size 1 units)
It.AC	20	Motor overload on current x time	Too much mechanical load High impedance phase to phase or phase to earth short circuit at drive output Drive requires autotuning to motor Motor or motor connections changed, re-autotune drive to motor (see parameter 38)
Oht1	21	Overheat	Overheat thermal model
Oht2†	22	Overheat (heatsink thermistor)	Temperature exceeds 95°C (203°F)
th	24	Over temperature (Motor thermistor)	Excessive motor temperature
O.Ld1*	26	+24V or digital output overload	Excessive load or short circuit on +24V output
cL	28	Current loop loss on terminal 5	Input current less than 3mA when 4-20 or 20-4 modes used
SCL	30	User serial communications watchdog failure	Failure of serial communications between drive and master

Trip Code	Trip Number	Condition	Possible Cause
EEF	31	Failure of internal EEPROM	Possible loss of parameter values Corruption due to severe electrical noise Set default parameters (see parameter 29)
PH	32	Phase loss	One of the input phases has become disconnected from the drive. (This applies to 200V/400V three phase units only, not dual rated units).
rS	33	Stator resistance measurement failure	Motor cable disconnected during measurement Motor too small for drive See parameter 38 for more details
trxx	40-99	User trips where xx is the user trip number	
F.bus	180	Field bus disconnection whilst in use	
C.Err	182	Quickey memory corrupt	Bad connection or memory corrupt
C.dat	183	Quickey with no data	New / empty Quickey being read Quickey / drive software compatibility issue
C.Acc	185	Quickey write fail	Bad connection or faulty Quickey
C.rtg	186	Quickey voltage rating change	Already programmed Quickey read by drive of different rating
O.Ld2	188	+28V serial communications power supply overload	Overload of more than 110 mA or short circuit on +28V serial communications power supply
O.cL††	189	Current loop input overload	Input current exceeded 25mA
		Motor runs unstable	Motor or motor connections changed. Check motor connections and re-autotune drive to motor (see parameter 38)

Table 8.1 Trip Codes

* The Enable/Reset terminal will not reset an O.Ld1 trip. Use the Stop/Reset key.

** These trips cannot be reset for 10 seconds.

† Commander SE Size 4 temperature exceeds 100°C (212°F)

†† See information under terminal 5 on page 37.

If any of the above trips persist, please consult a Drive Centre.

OU - Overvoltage trip levels:

200V units - 420Vdc

400V units - 830Vdc

Braking levels:

200V units - 390Vdc

400V units - 780Vdc

UU - Undervoltage trip levels:

200V units - 180Vdc

400V units - 400Vdc

Reset from UU - Under voltage trip:

200V units - 235Vdc


400V units - 460Vdc

NOTE

These are the absolute minimum DC voltages that the drive can be supplied by.

8.2 Alarm warnings

There are three ALARM codes which flash in the right hand display, along with the standard display, to warn the user that if no action is taken, the drive will trip. The codes are shown in Table 8.2.

For example: 

Display	Condition	Cause	Solution
OVL	l x t overload	Motor current greater than programmed rated motor current	Reduce motor current (load)
hot	Heatsink/IGBT junction temperature high	Drive running outside specified ambient temperature/motor current rating curves	Reduce ambient temperature or reduce motor current (load)
*br.rS	Braking resistor overload	Braking resistor thermal model exceeded	See <i>Commander SE Advanced User Guide</i>

Table 8.2 Alarm Warnings

* Does not apply to Size 1 units.

8.3 HF-Hardware fault trip codes

HF trips are internal hardware faults within the drive. Powering the drive down and re-applying power could clear the fault.

For full list of hardware fault trip codes, refer to the *Commander SE Advanced User Guide*.

NOTE

If a HF trip occurs, the Drive Healthy relay will open to indicate this. The serial communications will not function during a HF trip.

9 Parameter List

Par	Description	Default		Setting 1	Setting 2
		EUR	USA		
01	Min. speed (Hz)	0.0			
02	Max. speed (Hz)	50.0	60.0		
03	Accel. rate (s/100Hz)	5.0			
04	Decel. rate (s/100Hz)	10.0			
05	Ref. select	A1.A2	PAd		
06	Motor rated current (A)	Drive rating			
07	Motor rated speed (rpm)	1500	1800		
08	Motor rated voltage (V)	230 / 400	230 / 460		
09	Motor power factor	0.85			
10	Parameter access	L1	L1		
11	Preset 1 (Hz)	0.0			
12	Preset 2 (Hz)	0.0			
13	Preset 3 (Hz)	0.0			
14	Preset 4 (Hz)	0.0			
15	Jog. speed (Hz)	1.5			
16	Current mode (mA)	4-20			
17	Enable negative preset speeds	OFF			
18	Last trip	--			
19	Trip before parameter 18	--			
20	Trip before parameter 19	--			
21	Trip before parameter 20	--			
22	Load display units	Ld			
23	Speed display units	Fr			
24	Customer scaling	1.00			
25	Security setup	0			
26	Fwd/rev key enable	OFF			
27	Power up key. ref	0			
28	Parameter cloning	no			
29	Load defaults	no			
30	Ramp mode	1			
31	Stopping mode	1			
32	Variable torque select	OFF			
33	Spinning motor select	0			
34	Positive logic select	On			
35	Start/Stop logic select	0			
36	Analog output select	Fr			
37	Switching frequency (kHz)	6			
38	Auto tune	0			
39	Rated frequency (Hz)	50.0	60.0		
40	No. of poles	Auto			
41	Serial mode	AnSI			
42	Baud rate	4.8			
43	Serial address	1.1			
44	Software version	--			
45	Fieldbus node address	0			
46	Fieldbus baudrate	0			
47	Fieldbus diagnostics	0			
48	Voltage mode selector	3			
49	Low frequency voltage boost	3.0			
50	Motor thermistor select	OFF			
*51	Zero speed threshold	1.0			
*52	Motor current threshold	0			
*53	Motor current threshold hysteresis	0			
*54	Brake release delay time	0			

*Only becomes active when parameter 29 is set to 'br.Eu' or 'br.US' and the stop/reset button is pressed for 1 second.

10 Advanced Functions

The Commander SE can also offer many advanced functions. A full explanation of these can be found in the *Commander SE Advanced User Guide*.

10.1 Speed control

- Adjustable precision speed reference
- 3 adjustable skip frequencies with 3 adjustable skip bands
- 8 adjustable preset speeds

10.2 Ramps

- 8 preset acceleration ramps
- 8 preset deceleration ramps
- Separate acceleration and deceleration ramps for preset speeds
- Separate acceleration and deceleration ramps for jogging
- Adjustable S-ramp

10.3 Torque control

10.4 Stopping

- Adjustable DC injection braking current level and time

10.5 Programmable I/O

- Fully programmable analog and digital I/O for alternative functions

10.6 Motor protection

- Current limiting (short-term overload)
- Motor thermistor protection (long-term overload)
- Protection trips with trip log

10.7 Monitoring

- Programmable drive status logic
- Status and diagnostic information
- kWh meter
- Run time log
- Adjustable speed sensing levels
- Running costs

10.8 Auxiliary functions

- Auto reset
- PID controller
- Un-dedicated programmable logic
- Un-dedicated programmable threshold comparator
- Motorised potentiometer

10.9 Second motor selection

- With second motor map parameters

11 UL Listing Information

11.1 Common UL information

Conformity

The drive conforms to UL listing requirements only when the following are observed:

- Class 1 60/75°C (140/167°F) copper wire only is used in the installation.
- The ambient temperature does not exceed 40°C (104°F) when the drive is operating.
- The terminal tightening torques specified in Chapter 5 *Terminals* are used.
- The drive is installed into a separate electrical enclosure. The drive has a UL 'Open-type' enclosure rating.

AC Supply Specification

The drive is suitable for use in a circuit capable of delivering not more than 5000RMS symmetrical Amperes at 264Vac RMS maximum (200V models) or 528Vac RMS maximum (400V models).

Motor Overload Protection

The drive provides motor overload protection. The overload protection level is 150% of full-load current. It is necessary for the motor rated current to be entered into parameter 6 for the protection to operate correctly. The protection level may be adjusted below 150% if required. Refer to the *Commander SE Advanced User Guide* for further information.

Overspeed Protection

The drive does not incorporate overspeed protection.

11.2 Power dependant UL information

11.2.1 Commander SE Size 1

Conformity

The drive conforms to UL listing requirements only when the following is observed:

- UL listed class CC fast acting fuses e.g. Bussman Limitron KTK series, Gould Amp-Trap ATM series or equivalent are used in the AC supply.

11.2.2 Commander SE Size 2

Conformity

The drive conforms to UL listing requirements only when the following are observed:

- UL listed class CC fast acting fuses e.g. Bussman Limitron KTK series, Gould Amp-Trap ATM series or equivalent are used in the AC supply for 200 and 400Vac input models with the following exceptions:
- The SE2D200220 when operated from a single phase supply must use a 35A UL listed class J fast acting fuse e.g. Gould Amp-Trap A4J35 or Littelfuse Power-Gard JLS35.
- With reference to Table 3.7, the SE23200400 may use 30A UL listed class CC fast acting fuses.
- The power input wiring for the following models should be terminated with UL listed (to UL486A/C) 12 AWG ring terminals (max. allowable diameter 8.0mm):
SE2D200220 when used on a single-phase supply
SE23200400

11.2.3 Commander SE Size 3, 200V product

Conformity

The drive conforms to UL listing requirements only when the following is observed:

- UL listed class J 35A fast acting fuses e.g. Gould Amp-Trap A4J35, Littelfuse Power Gard JLS35 or equivalent are used in the AC supply.

11.2.4 Commander SE Size 3, 400V product

Conformity

The drive conforms to UL listing requirements only when the following is observed:

- UL listed class CC fast acting fuses e.g. Bussman Limitron KTK series, Gould Amp-Trap ATM series or equivalent are used in the AC supply.

11.2.5 Commander SE Size 4

Conformity

The drive conforms to UL listing requirements only when the following is observed:

- UL listed class J 40A fast acting fuses e.g. Gould Amp-Trap A4J40, Littelfuse Power-Gard JLS40 or equivalent are used in the AC supply.

11.2.6 Commander SE Size 5

Conformity

The drive conforms to UL listing requirements only when the following is observed:

- The drive is installed in a Type 1 enclosure, or better, as defined by UL50
- UL listed class RK1 600Vac fuses are used in the AC supply

11.2.7 Commander SE RFI Filters

All recommended filters for Commander SE are UL recognised components, including for Canada (CUL), under file number E64388.