

RAC 3 Main Spindle Drive Controller

Project Planning Manual

DOK-DIAX01-RAC03*****-PRJ1-EN-P



Titel Main Spindle Drive Controller RAC 3

Type of documentation: Planning and Design

Documenttype DOK-DIAX01-RAC03*****-PRJ1-EN-E1,44

Internal file reference • 209-0042-4116-00

Reference This electronic document is based on the hardcopy document with document desig.: 209-0042-4116-00 EN/03.94

This documentation is used: This documentation serves

- to introduce the drive controller
- to mechanically integrate the drive controller into the control cabinet
- to assist in assembly and installation
- to describe the AS programming module
- to explain the hardware delivered and its best storage conditions

Function of the supplementary documentation The supplementary technical documentation is used

- during commissioning, operation and servicing
- to electrically integrate the drive controller into the control cabinet

The „documentation summary“ offers an overview of all technical documentation of the main spindle drive and contents.

The „supplementary documentation“ summary lists all titles and their order numbers.

Change procedures

Designation of documentation up to present edition	Release-date	Comments
209-0042-4116-00 EN/03.94	Mar./94	First Edition
DOK-DIAX01-RAC03*****-PRJ1-EN-E1,44	Jul./97	First E-Dok

Copyright © INDRAMAT GmbH, 1994
 Copying of this document, and giving it to others and the use or communication of the contents thereof, are forbidden without express authority. Offenders are liable to the payment of damages.
 All rights are reserved in the event of the grant of a patent or the registration of a utility model or design. (DIN 34-1)

The electronic documentation (E-doc) may be copied as often as needed if such are to be used by the consumer for the purpose intended.

Validity All rights reserved with respect to the content of this documentation and the availability of the products.

Publisher INDRAMAT GmbH • Bgm.-Dr.-Nebel-Straße 2 • D-97816 Lohr
 Telefon 0 93 52 / 40-0 • Tx 689421 • Fax 0 93 52 / 40-48 85

Dept ENA (MR, FS)

Table of contents

1. The RAC 3 main spindle drive controller	5
2. Control Cabinet Construction	11
2.1. Environmental conditions	11
2.2. Mechanical data	14
2.3. Thermal data	20
2.3.1. Guidelines on the use of cooling devices in control cabinets	22
2.4. Electrical data	24
2.5. Summary of technical data	31
2.6. Type codes	32
3. AS programming module	33
3.1. Types of AS programming modules	34
3.2. The compatibility of AS programming modules	34
3.3. Rating plate information	35
3.4. Type codes	36
4. Condition upon delivery	37
5. Identifying the merchandise	38
6. Storage and transportation	41
7. Assembly	42
7.1. Installing the drive controller in the control cabinet	44
8. Installation guidelines	45

9. Commissioning guidelines	46
10. Servicing guidelines	47
10.1. Fault diagnosis	47
10.2. Defective controller	47
11. Index	49
12. Supplementary documentation	52

1. The RAC 3 main spindle drive controller



Figure 1.1: The RAC 3 main spindle drive controller

The RAC 3 main spindle drive controller provides intelligent digital control of INDRAMAT 2AD asynchronous main spindle motors and 1MB frameless spindle motors with a continuous power at the motor output shaft of 10 to 30 kW.

Main spindle drive Drives using an RAC 3 drive controller have high stiffness and a broad speed range with constant power. This makes them particularly well-suited for use as main spindle drives in numerically controlled machine tools.

Spindle positioning The AC main spindle drive with RAC 3 has an internal position control loop, in addition to its broad speed range. It independently positions the spindle, e.g., for changing a workpiece, with a maximum resolution of 1/4 000 000th of the revolution after receiving a signal. The internal position control loop of the controller is closed by either the motor feedback (with direct drive or 1:1 gears), or by an additional, optional spindle feedback (gear box, belt gears).

C-axis operation The AC main spindle drive with RAC 3 can also operate the spindle in the capacity of a servo axis (C-axis) with extreme precision in the position control loop. The main spindle drive is equipped with high resolution feedback for the low speeds which this requires. The drive controller acknowledges rotor position with a maximum resolution of 1/4 000 000th of a revolution. This means that even the lowest speeds can be accurately controlled.

Drive controller for direct connection to the mains

The RAC 3 can be directly connected to a three-phase supply network with 3 x AC 380 volts ... 460 volts, +/- 10%, 50 ... 60 Hz. Both mains contactor and emergency-stop circuits are integrated. The energy recovered during braking is fed back into the three-phase supply network. This also occurs in an emergency stop. In the event of mains failure, the drive with RAC 3 can bring the main spindle to rest, if the RAC3 is equipped with the additional, optional bleeder.

Cooling

The heatsink for both the power electronics and fan is built into the housing of the RAC main spindle drive controllers. The cooling air is fed through an air shaft within the unit.

The RAC drive controllers can be cooled using air from inside or outside the control cabinet. Every RAC offers either option. Any required structural changes are simple and can be performed without accessories.

Cooling with air inside the control cabinet

The cooling air flow is drawn in and blown out within the control cabinet.

Cooling with air outside the control cabinet

The cooling air is drawn in from outside the control cabinet through slits in the back wall of the cabinet, and then blown out. Heat from energy loss is fed into the outside air of the control cabinet.

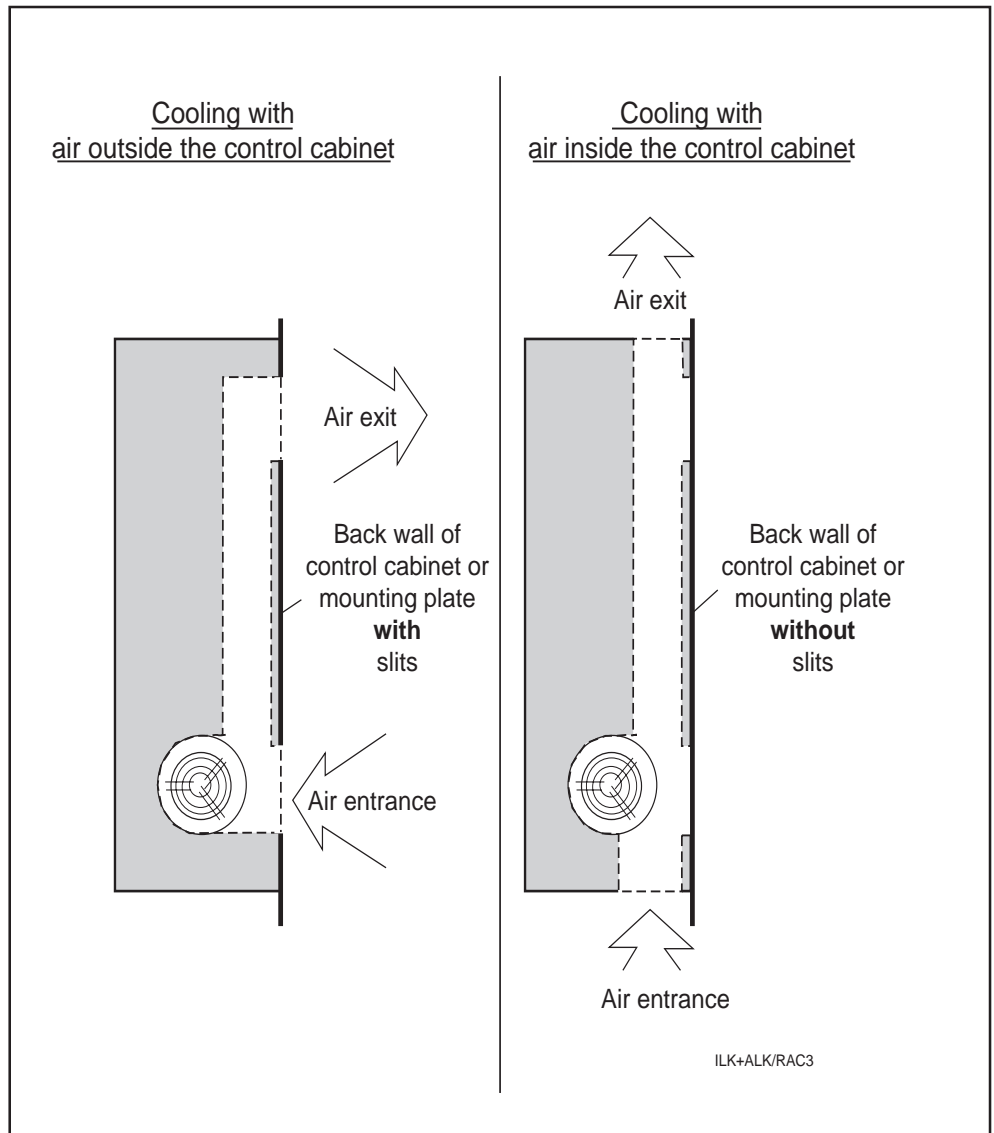

Figure 1.2: Possible cooling methods for the RAC 3

Hose cooling If for structural reasons it should not be possible to put slits into the back wall of the control cabinet, then the RAC 3 drive controller can be equipped with hose cooling.

Here, the cooling air is drawn in and blown out through a hose outside of the control cabinet.



Mounting accessories are needed if hose cooling is used. These come in the form of an assembly kit. The hose itself is not a part of this kit, but it can be ordered from INDRAMAT.

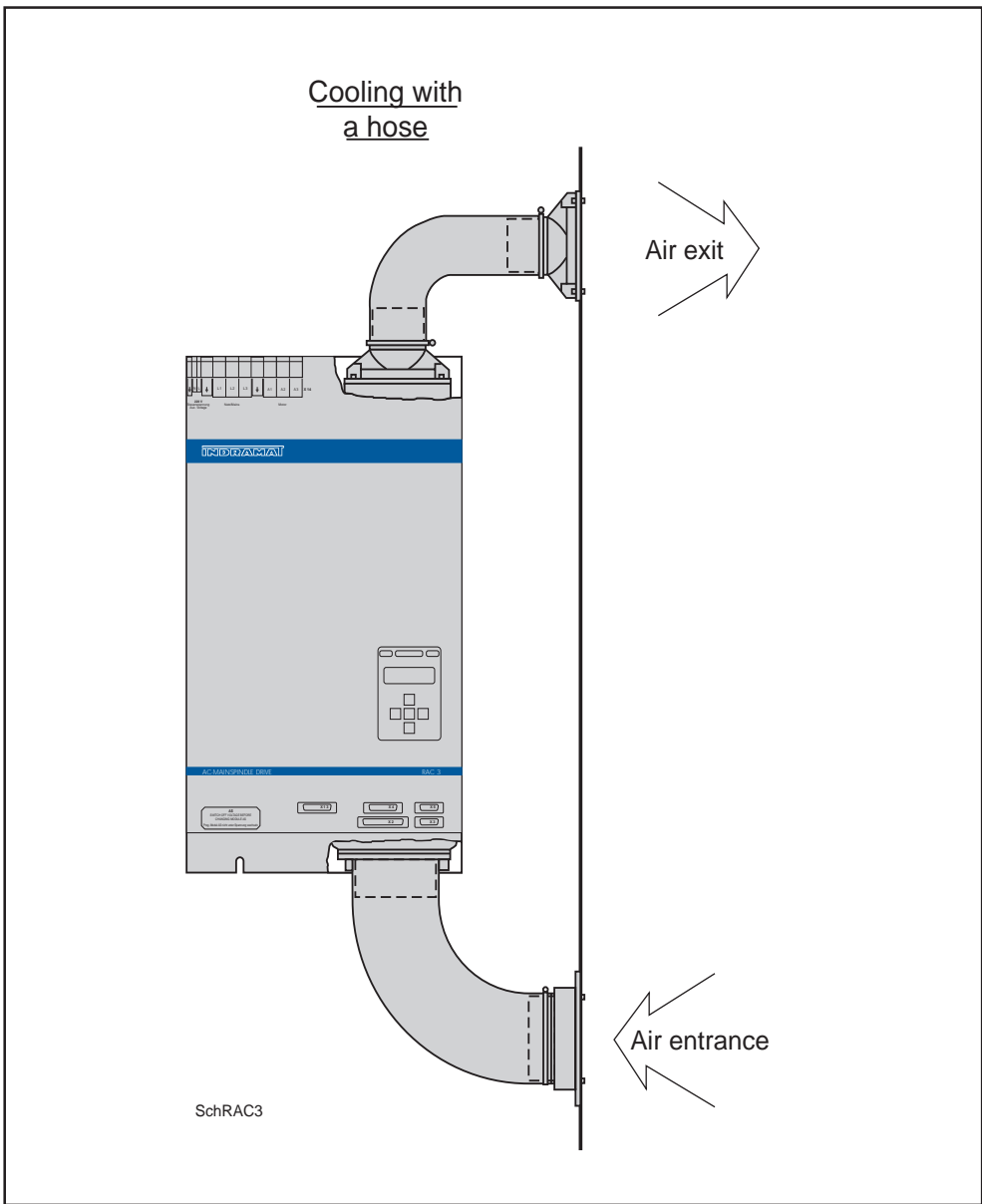

Figure 1.3: Cooling the RAC 3 with a hose

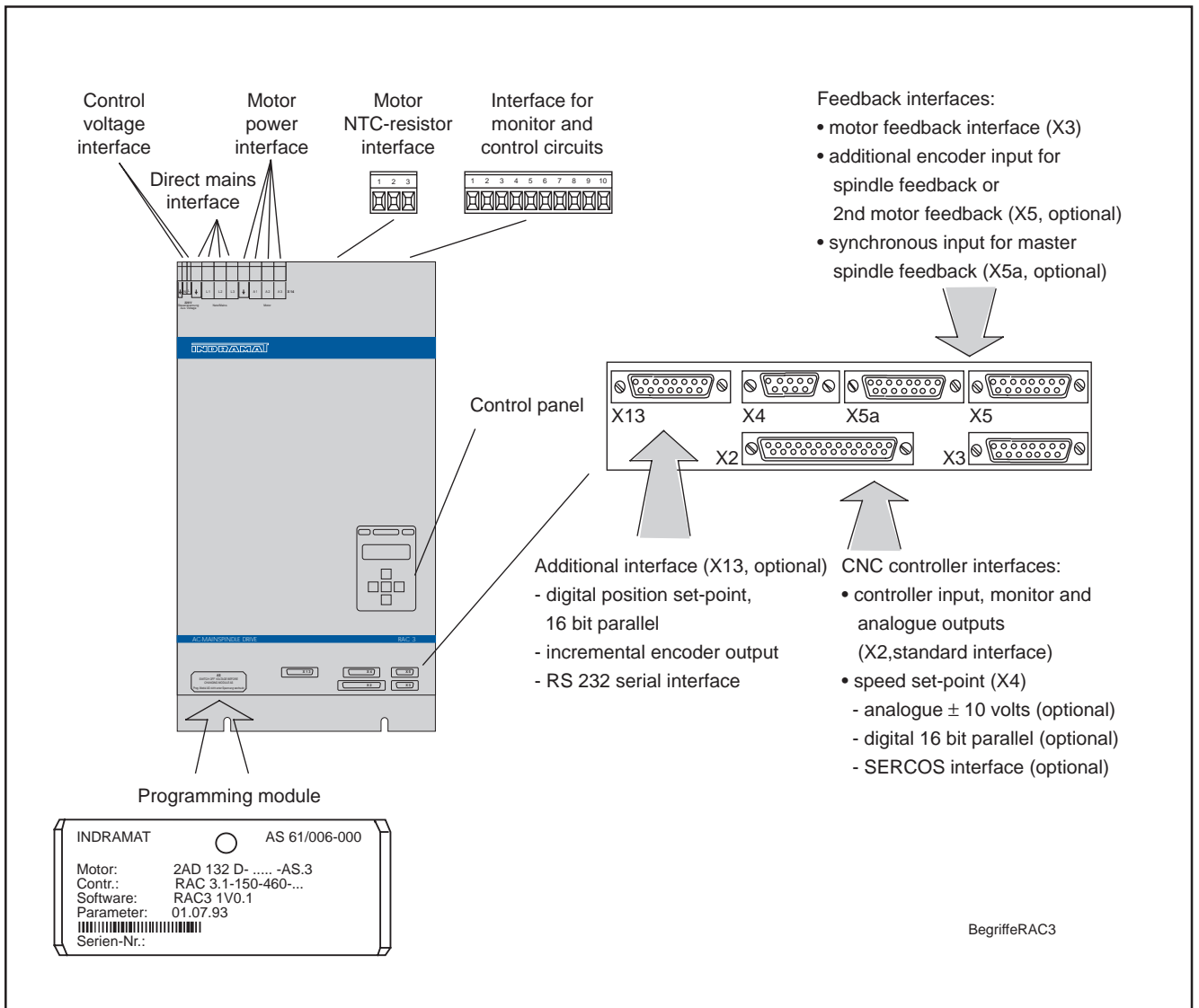

Figure 1.4: Allocation of terms on the RAC 3

Programming module The individual parameters needed for the plant and application are programmed at the time of commissioning on site with the keypad on the control panel. These parameter values are stored, along with the matching motor parameter values, on the plugged-in programming module.

Should servicing become necessary, then only the controller need be exchanged. The same programming module is used in the new controller. The drive parameters are stored on the programming module and are immediately available for use.

Interface options

Speed set-point The drive controllers are available with different speed set-point interfaces:

- analogue speed set-point
+/- 10 volts for connection to conventional CNC controls,
- digital speed set-point
16 bit parallel for connection to PLCs, advantageous with long line distances and low set-points,
- SERCOS interface
for real time communication with the CNC controls of speed, position and torque set-points and actual values including parameter handling.

Additional encoder and synchronous input

An additional encoder input is available for connecting a spindle feedback to the internal position controller. Additional encoder and synchronization input (master spindle feedback connection) are available for spindle synchronization.

Additional interface

The RAC 3 drive controller also offers an additional, optional interface which is available in the form of

- an incremental encoder output
for position control by the CNC control with C-axis operation or screwing, tapping,
- a serial interface
for storing and loading parameter values with a PC,
- input for digital position set-point
16 bit parallel, for 3,600 positions which can be selected with the use of a PLC.

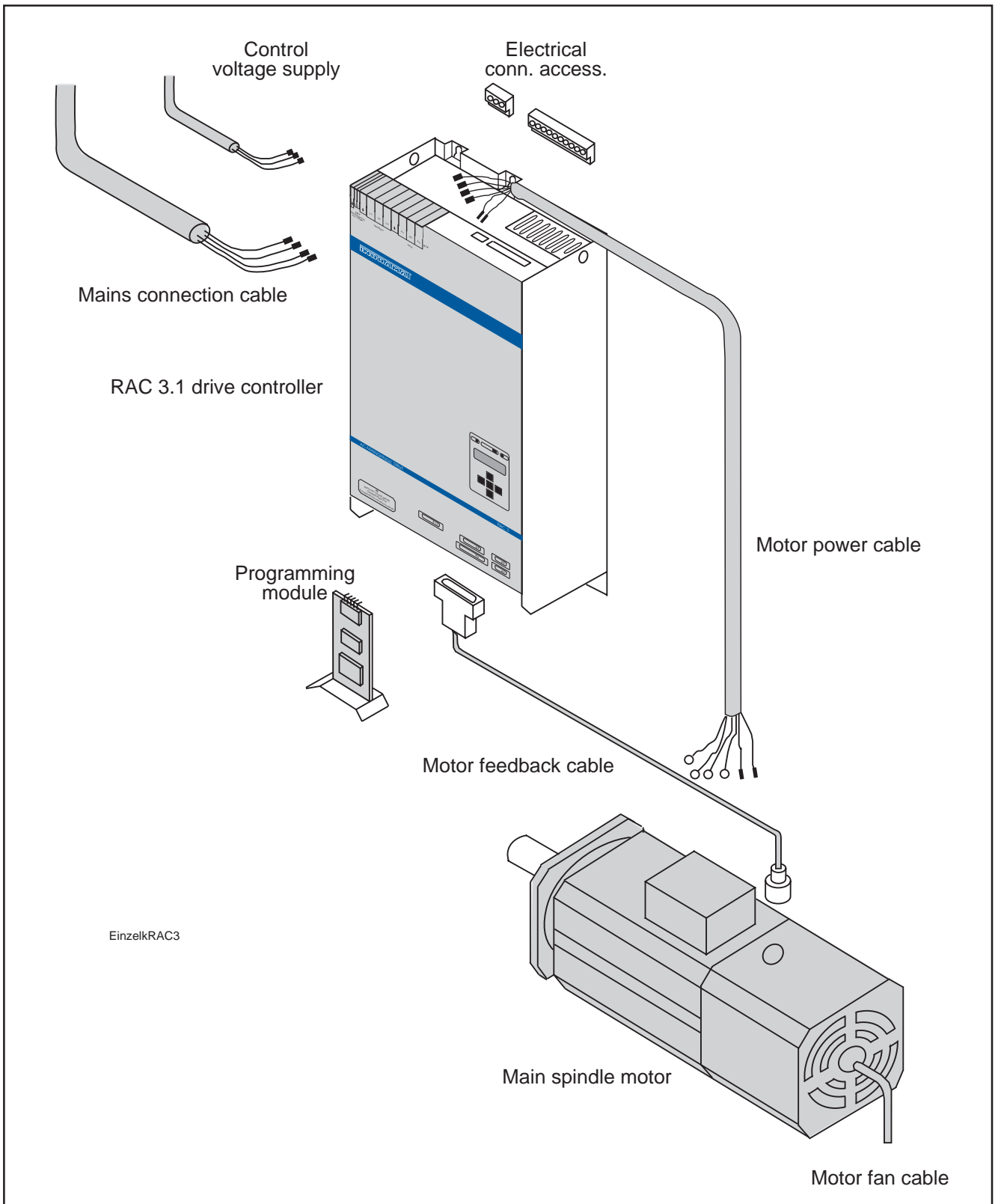

Figure 1.5: Individual components of a main spindle unit with allocation of terms

2. Control Cabinet Construction

The information for structurally integrating the RAC 3 main spindle drive controller is broken down into

- environmental conditions
- mechanical data
- thermal data
- electrical data
- technical data/type codes

2.1. Environmental conditions

Ambient temperature

The values listed in the selection data for the main spindle drives are valid without restriction if the controller is operated within an ambient temperature range of +5 to +45 degrees C. Permissible maximum ambient temperature is +55 degrees C. The graph in figure 2.1 depicts the reduction in rated data.

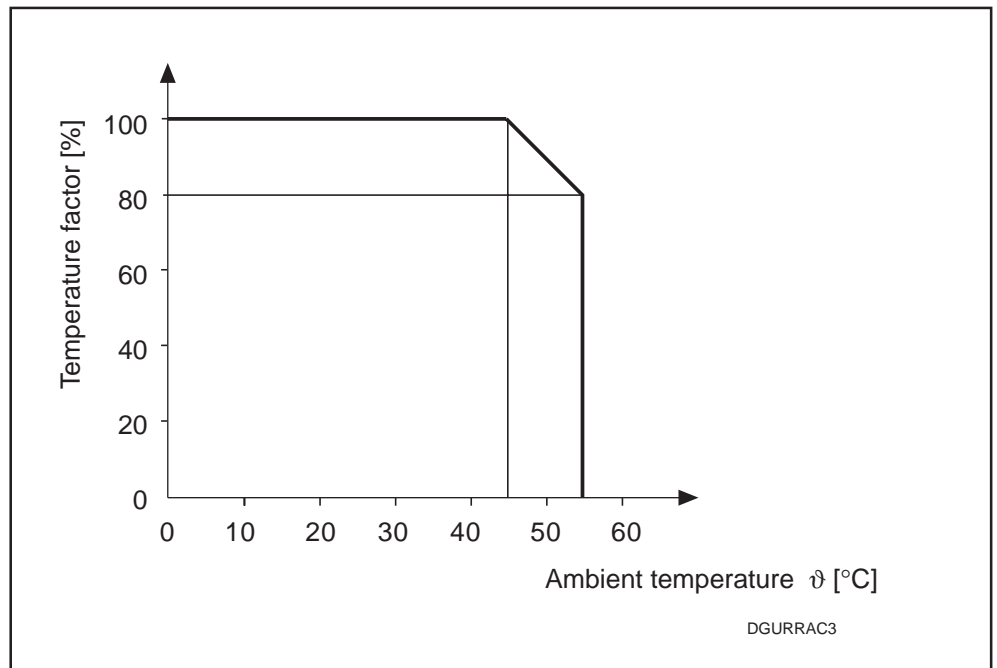

Figure 2.1: Ambient temperature-dependent reduction in drive data

Installation altitude Maximum installation altitude is 1000 meters above sea level. There is a drop in values for rated torque or power as listed in the selection specs for main spindle installed at higher altitudes. The graph in Figure 2.2 depicts this drop.

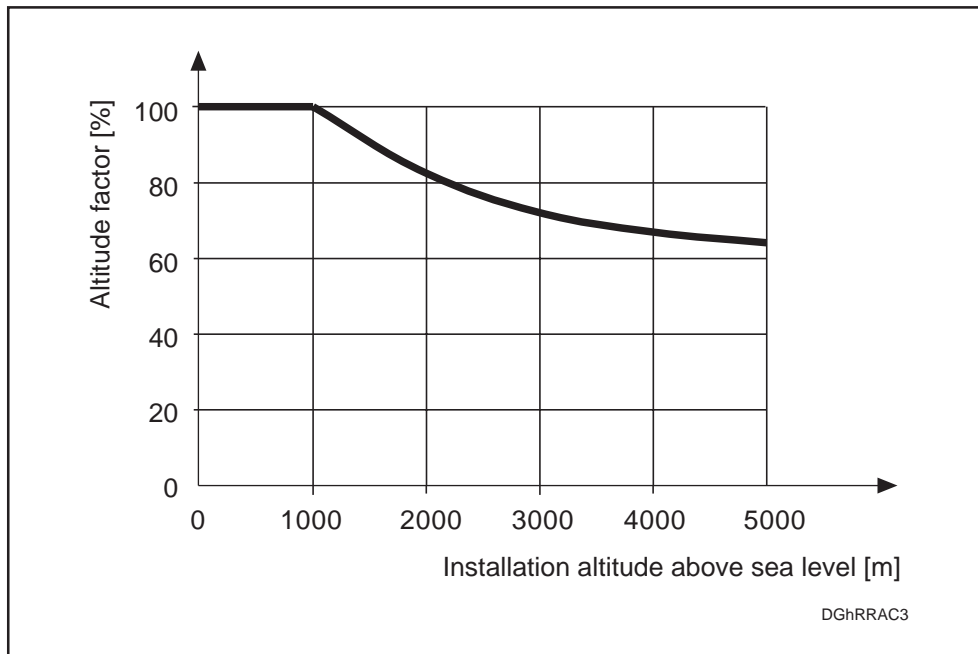

Figure 2.2: Altitude-dependent drop in drive data

Permissible ambient humidity

The maximum ambient humidity is humidity class F, as per DIN 40 040.

This means that the controller can be operated in humidity-endangered areas such as workshops in cold, moderate and warm and moist climactic regions. The mean relative humidity may not exceed 70% in the most humid month of the year! Beware of condensation water!

Protection category of the RAC controller

Protection category is IP 10, as per EN 60 529 (DIN VDE 0470).

This means the controller is protected against penetration by foreign objects greater than 50 mm in diameter.

The controller is not protected against

- water and
- deliberate penetration, e.g., by a hand. It does keep larger body surfaces out.

The RAC 3 is manufactured as per DIN VDE 0160, Sections 5.5.1.3 and 6.5.1.3 for installation into a control cabinet or closed housing. Sufficient safety measures must be taken in the respective control cabinet design. The measures taken must correspond to the safety guidelines for a specific application. (For industrial equipment, e.g., EN 60204 / DIN VDE 0113, Section 1).

*Category of protection
for the control cabinet*

The type of protection needed for the control cabinet is not affected if the RAC drive controller is cooled with air inside the control cabinet.

The type of protection needed for the control cabinet is affected if the RAC drive controller is cooled with outside air because the air current is fed through the control cabinet over slits in the back wall.

Assembly as per guidelines (Section 7) means that IP 54 is the category of protection for the interior of the control cabinet. IP 24 is the protection category for the fan (see Figure 1.2).

2.2. Mechanical data

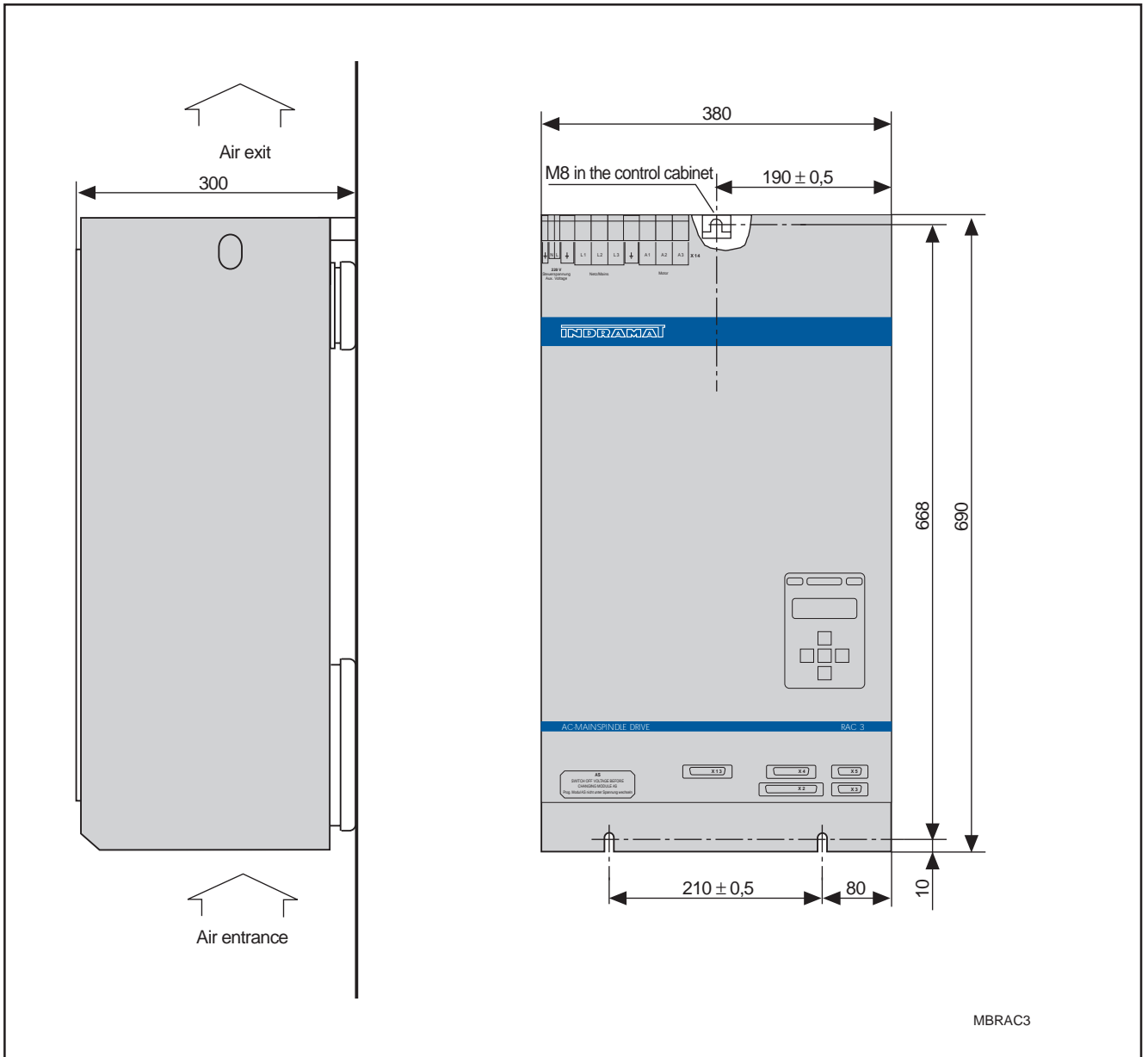

Figure 2.3: RAC 3 main spindle drive controller dimensional data

The controller may only be operated in the position shown!

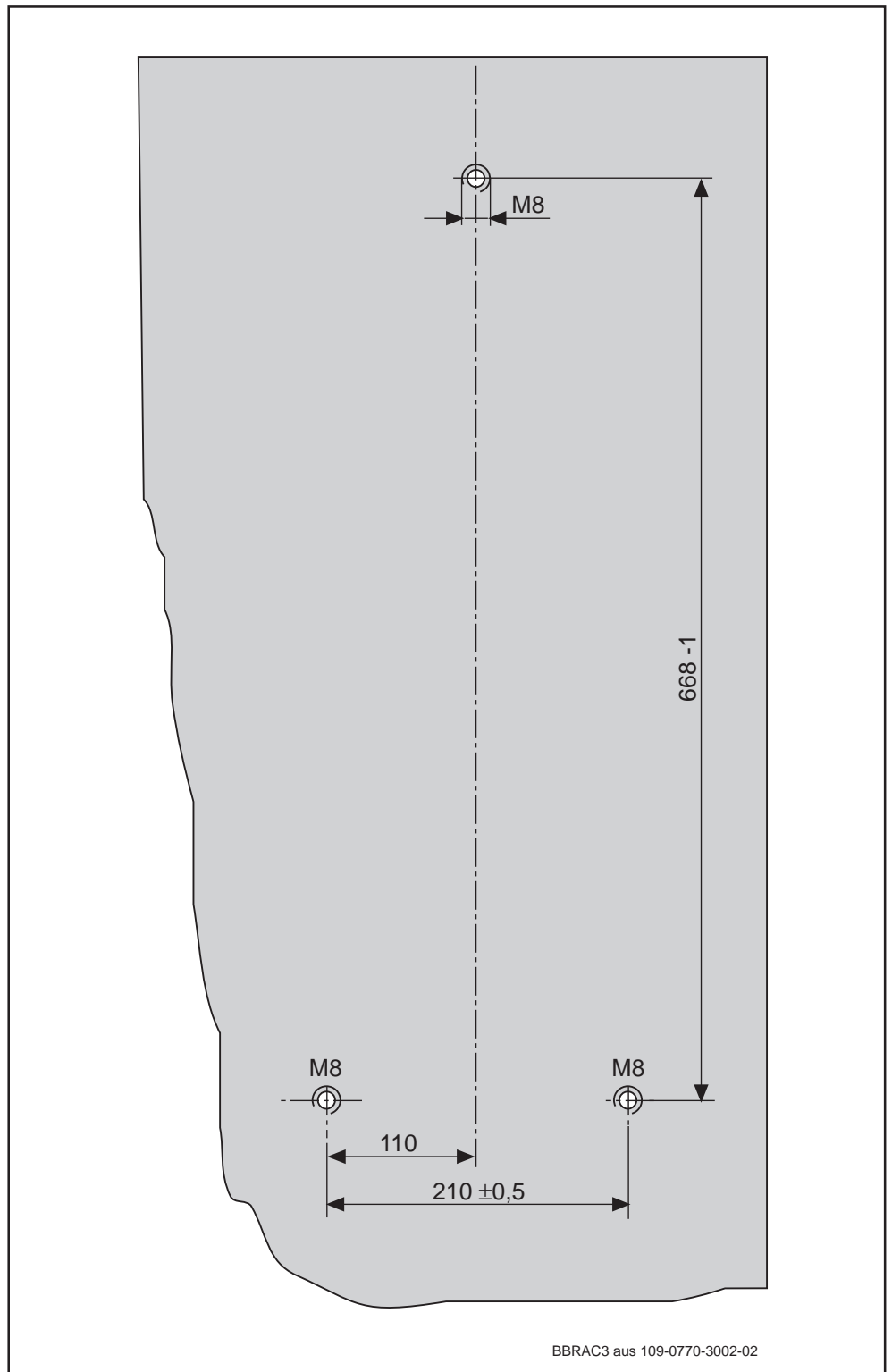

Figure 2.4: The drill diagram for the back wall of the control cabinet

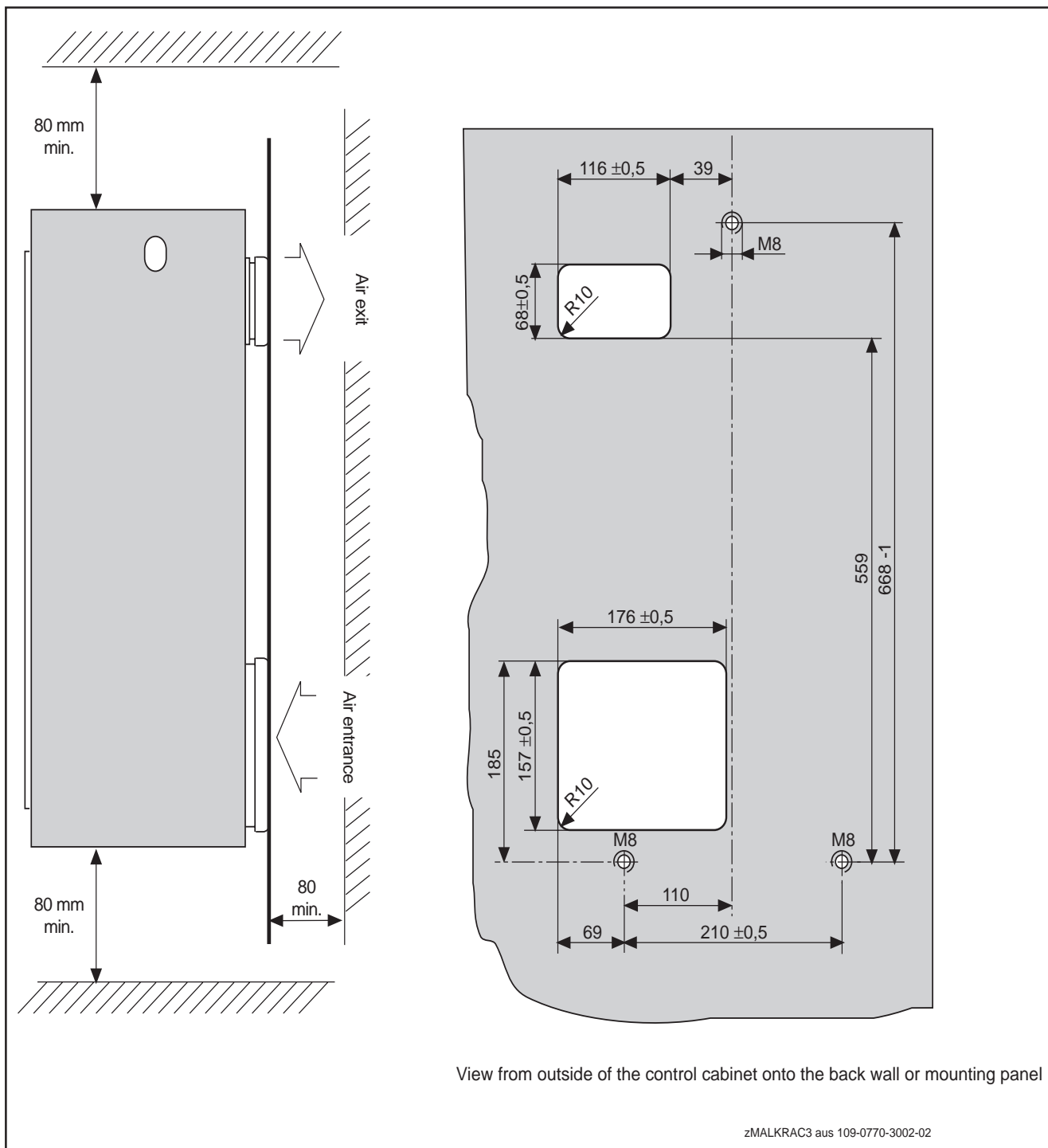

Figure 2.5: Additional dimensions for cooling with air outside of the control cabinet

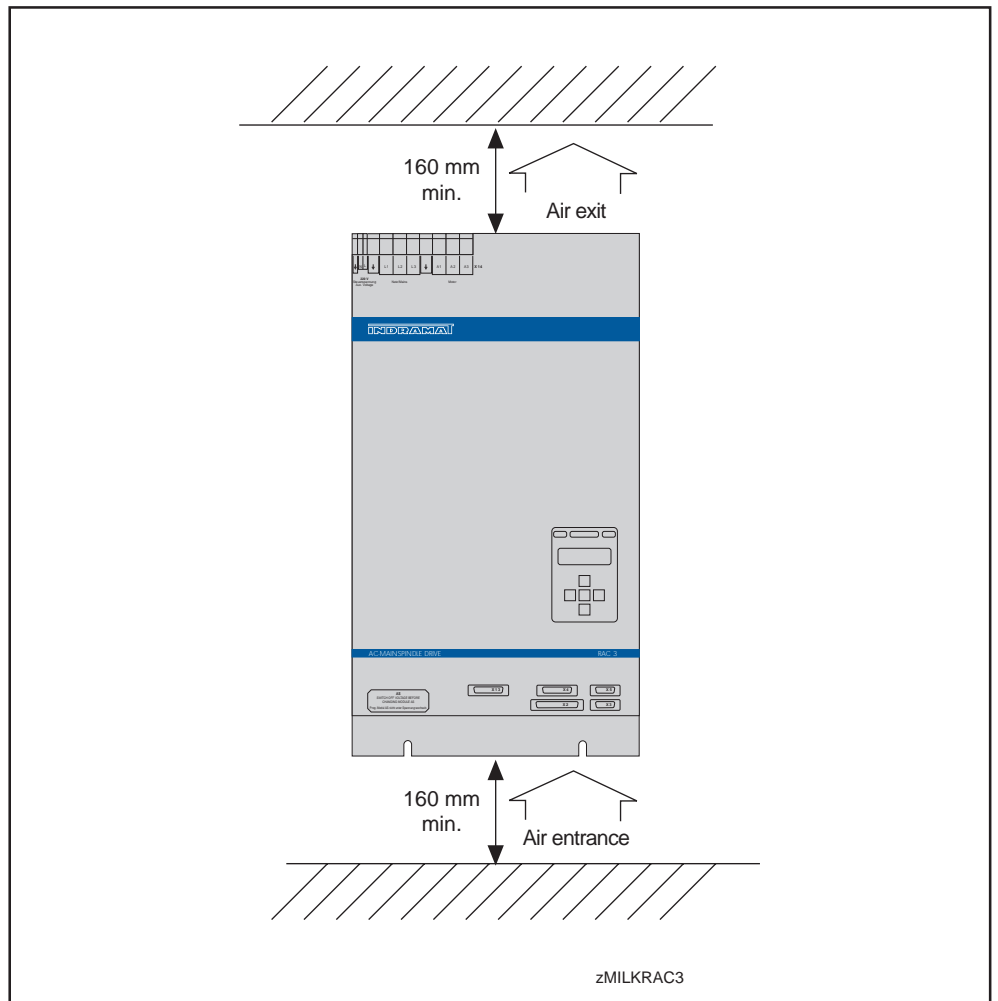

Figure 2.6: Additional dimensions for cooling with air inside the control cabinet

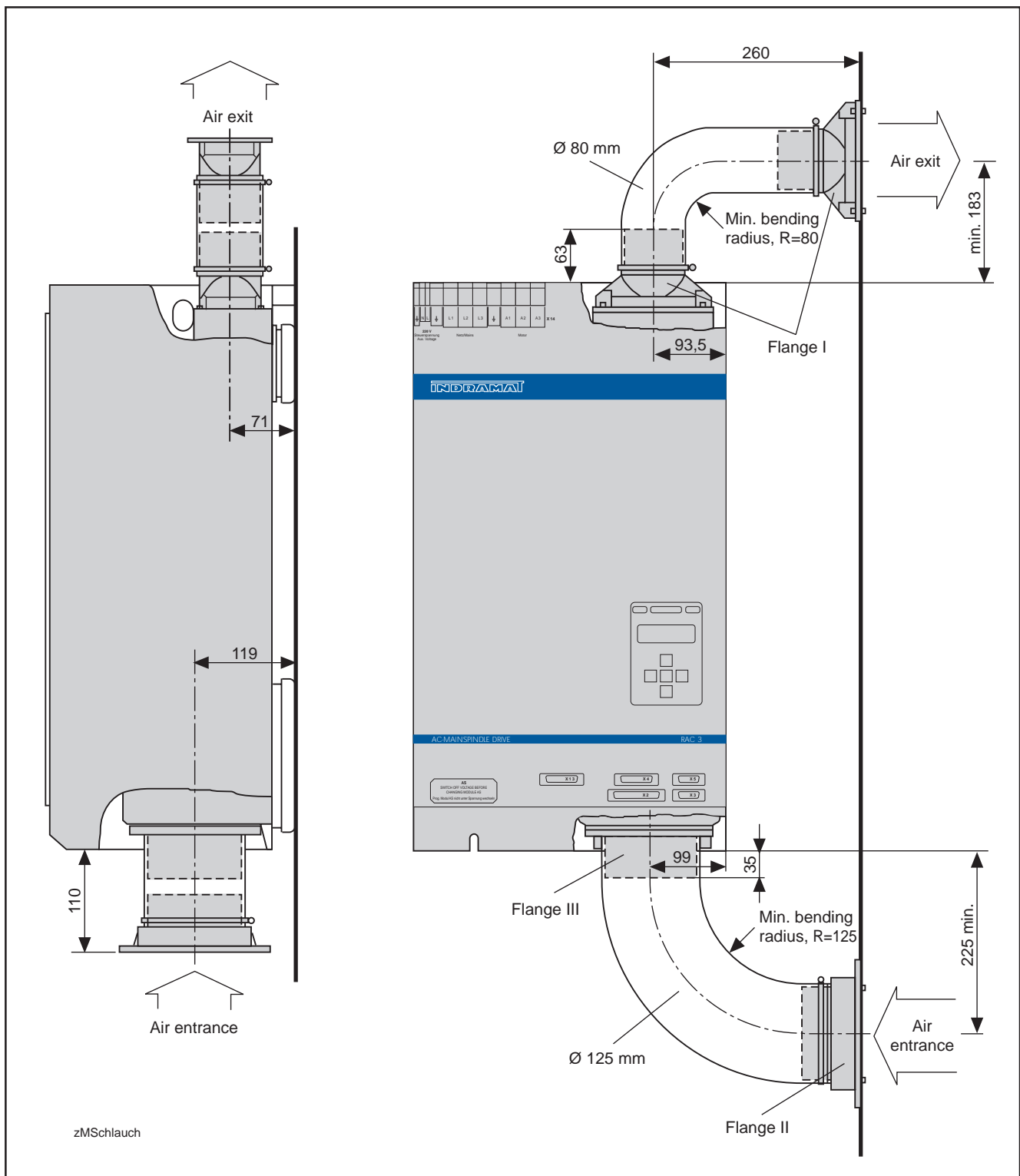

Figure 2.7: Additional dimensions for hose cooling

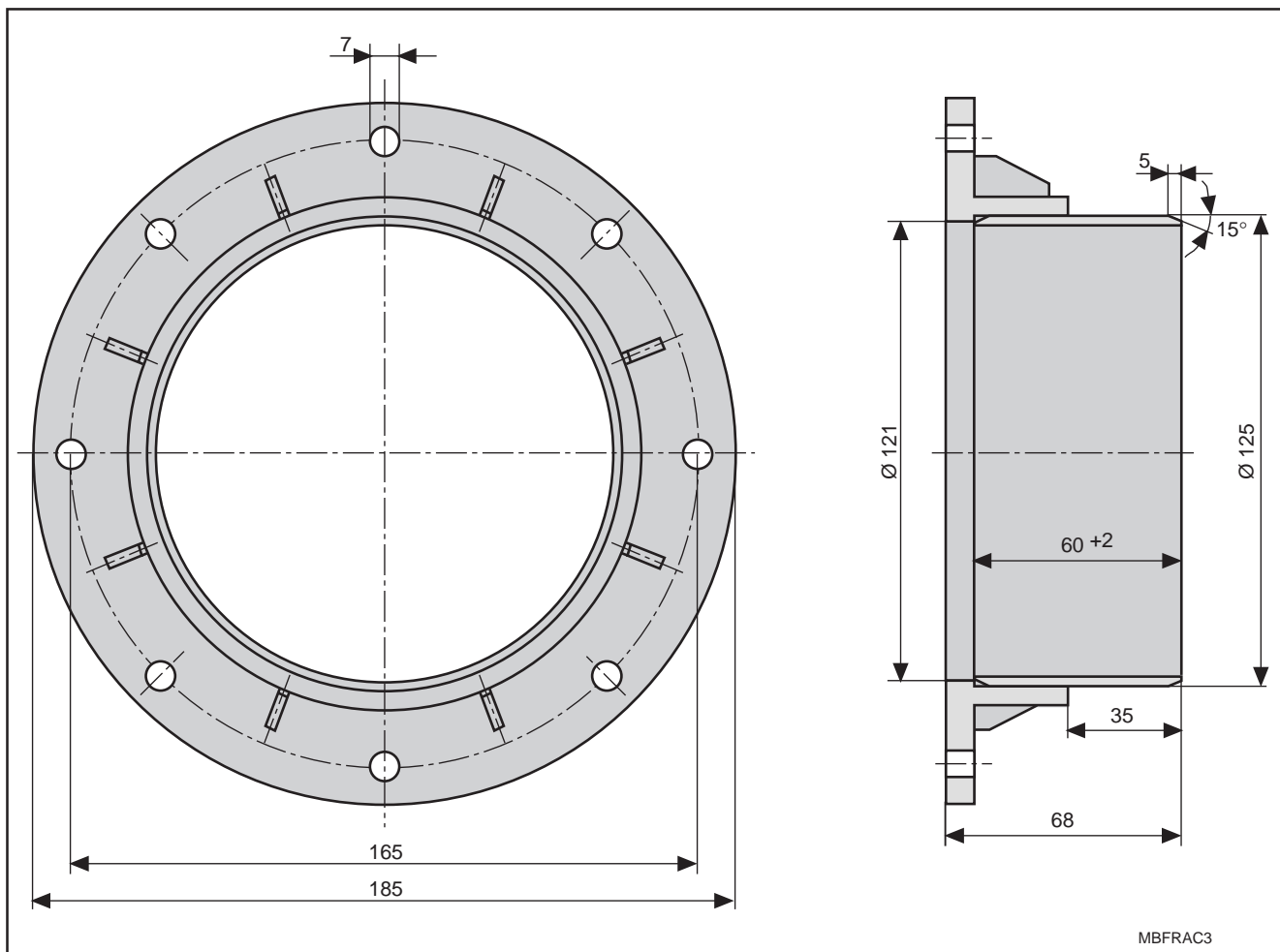

Figure 2.8: Flange II dimensional data for hose cooling

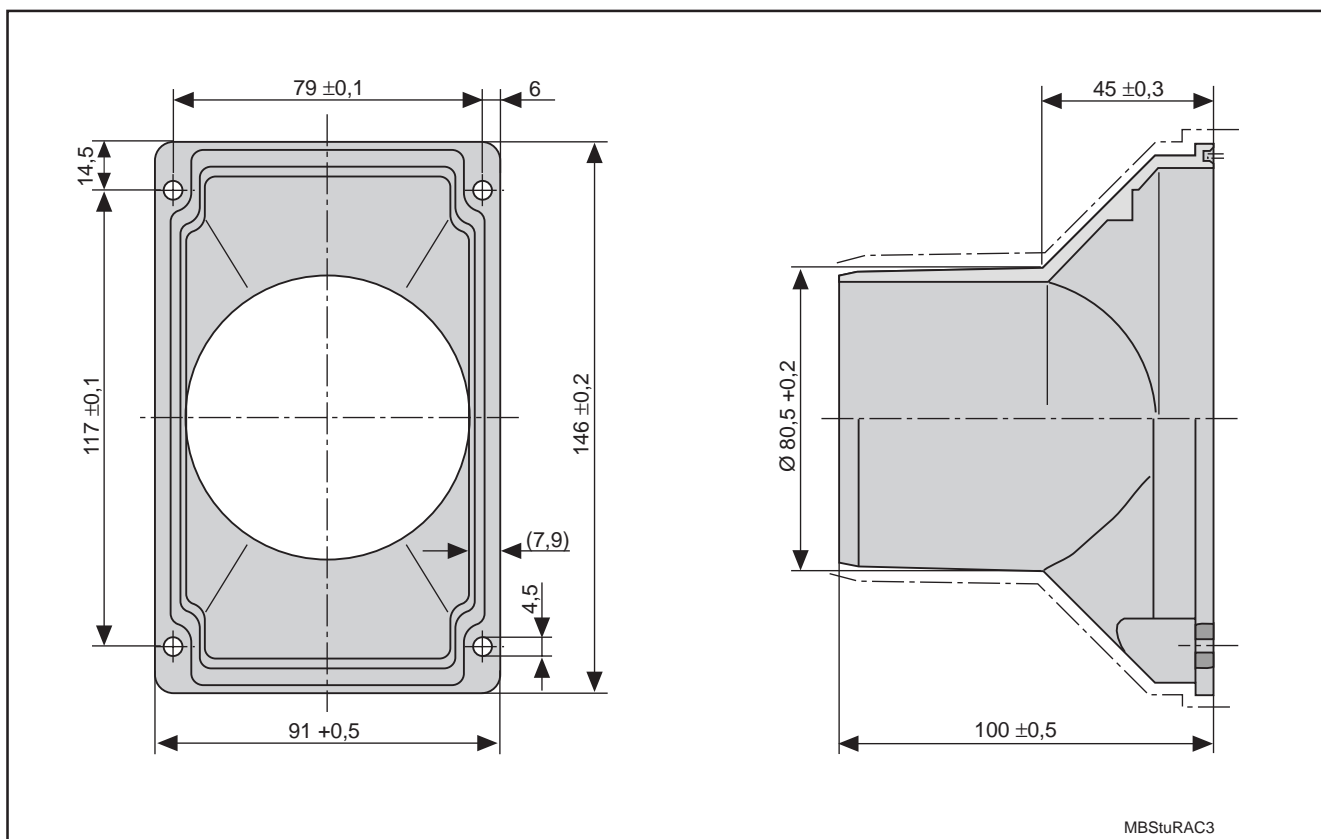

Figure 2.9: Flange I dimensional data for hose cooling

2.3. Thermal data

Power dissipation The RAC 3 drive controller emits heat during operation over the air slits in the lid of the controller and over the heatsink built into the unit.

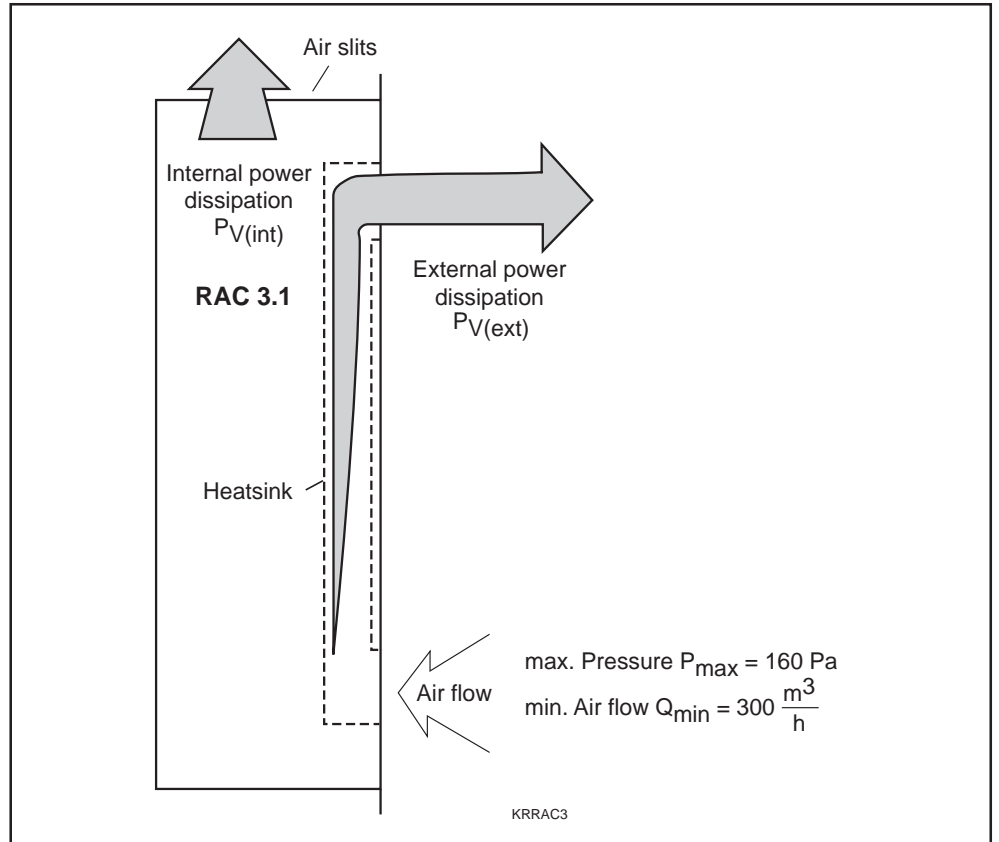

Figure 2.10: Cooling the RAC 3 drive controller

The external and internal power dissipation produced by the RAC 3 drive controller is workload dependent. When working out the proportions of the control cabinet or the exhaust air cooling set-up it suffices to know the radiation of heat dependent upon the rated current of the main spindle motor used.

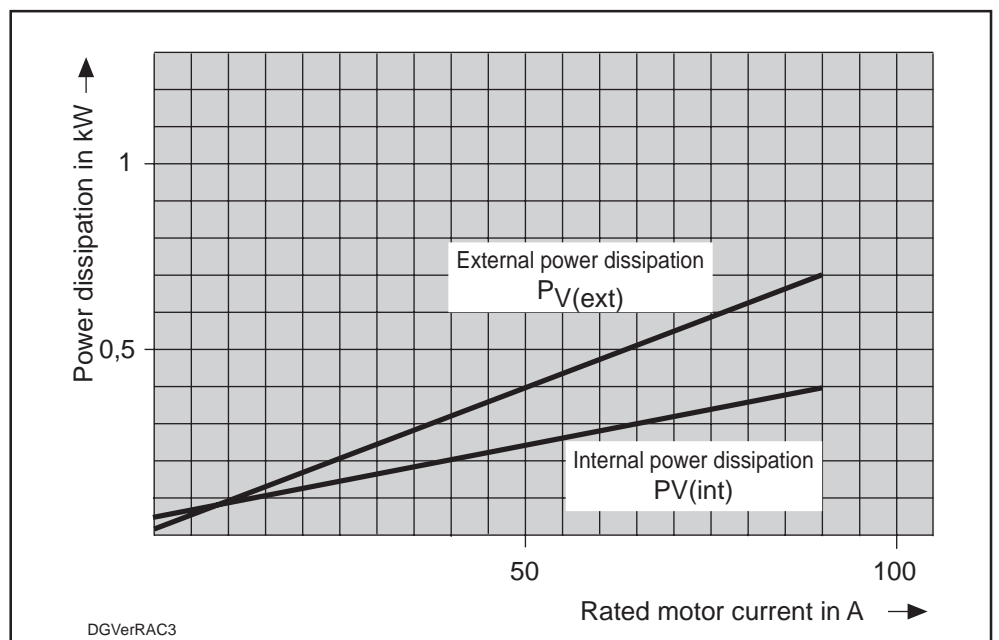

Figure 2.11: Break down of internal and external power dissipation

The unit can be cooled with air from inside or outside the control cabinet. The cooling air for the heatsink remains either inside or is drawn in from outside and then blown out again, depending upon installation method (principle of heat exchange).

The unit is delivered with the inside air cooling method. If a cooling method using either outside air or a hose is used, then the unit must be structurally altered (see Sec. 7).

The dimensions of the air shaft must be taken into consideration if air is to be fed in and out over an air shaft (required air flow!).

If the hose cooling method is used, then the hoses should be kept as short as possible and should not have more than two bends of 90 degrees per hose.

The values for air flow, Q , and maximum permissible excess pressure, P_{max} , should be controlled as a safety measure.



Air shafts and heatsink should be kept clean to avoid overheating!

2.3.1. Guidelines on the use of cooling devices in control cabinets

The RAC 3 drive controller can only be operated up to an ambient temperature of 45 degrees C. before the drive data begins to drop. It may be necessary to use a cooling device to cool the air inside the control cabinet to maintain the environmental conditions.

Dew and condensation water endanger the installed controller if cooling devices are not properly installed!

Danger from condensation

Humid air enters the control cabinet and condenses on the controller as it cools down!

Danger from condensation water

The condensation water continually formed in cooling devices can drip onto the controller or be sprayed into the cooling air flow if the cooling device has not been properly installed.

Proper use of cooling devices

- Use only a well-sealed control cabinet if a cooling device is also used so that moist and warm air cannot penetrate to form condensation!

Avoiding condensation

- Should a control cabinet be operated while a door is open (upon commissioning, during servicing, etc.), then it must be warranted that the controller at no point in time after closing the door is cooler than the air inside the control cabinet as otherwise condensation could form. The cooling device should continue to run for this reason even when the unit is shutdown, until the temperature of the control cabinet air and the installed unit remain at the same level.
- Cooling devices with fixed temperature settings have to be set at 40 degrees C., no lower!
- Cooling devices with follow-up temperatures should be set so that the temperature of the air inside the control cabinet is less than 2 degrees C. below the temperature of the outside air. Set temperature limit at 40 degrees C.!

Avoiding dripping and spraying

- Always arrange cooling devices so that any condensation water formed does not drip onto the installed drive controllers. Cooling devices on the top of a control cabinet necessitate a special control cabinet design (see Fig. 2.12)!
- Construct the control cabinet in such a way that the cooling device fan cannot blow the condensation water formed during shut downs onto the drive controller (see Fig. 2.13)!

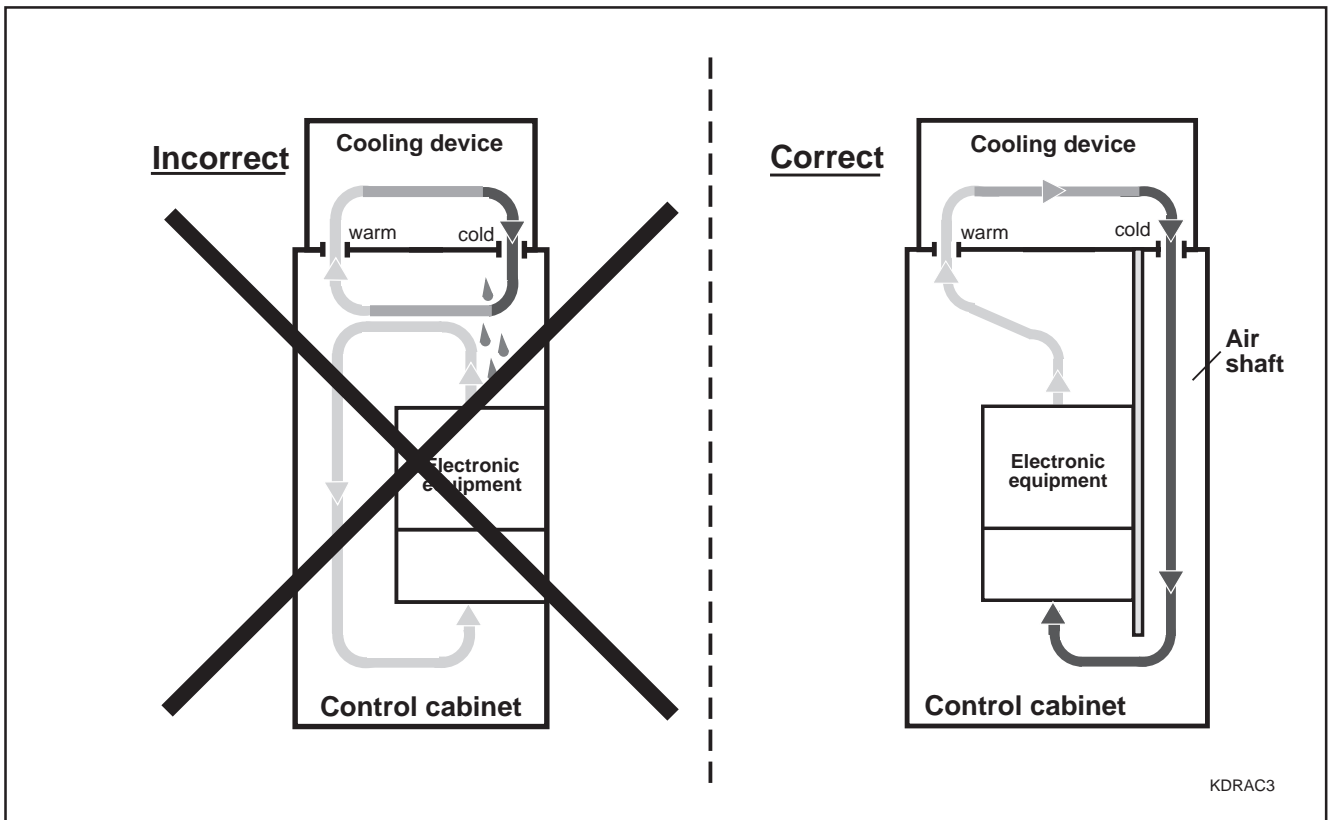

Figure 2.12: Placing the cooling device on the top of the control cabinet

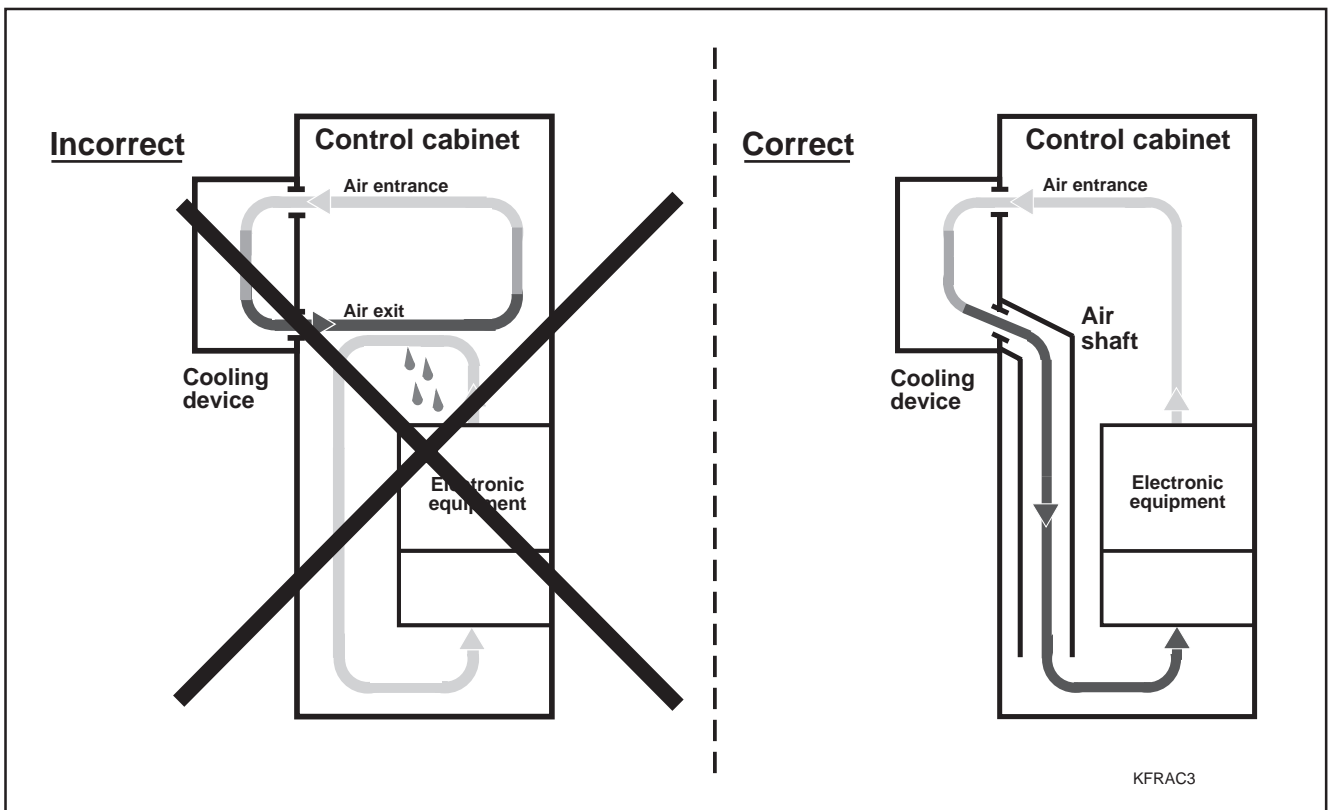

Figure 2.13: Placing the cooling device on the front of the control cabinet



Cooling devices may not drip condensation water onto the installed drive controller! The correct cooling device temperature must be maintained!

2.4. Electrical data

Connecting diagram (schematic) The connecting diagram depicted in Figure 2.14 is schematic in nature. It is the checklist for all the electrical connections required to operate a main spindle drive.

The electrical connections of INDRAMAT main spindle drives are standardized to keep the range of cables offered limited.

There are three categories of electrical connections for all INDRAMAT main spindle drives:

- feedback and CNC connections
- power connections
- controller-specific connections

Connection diagrams for feedback, CNC and power connections The feedback, CNC and power connections (mains and motor power connections) have the same plug and terminal assignments regardless of the main spindle drive controller. The connecting diagrams are therefore summarized in the document, „Electrical connections of main spindle drives; planning and design“, (doc. no. 209-0042-4111). This document is a must when developing the plant connecting diagrams!

Connecting the controller-specific connections To integrate the RAC 3 drive controller into the control circuits of the control cabinet, the already mentioned electrical connections as well as mains contactor control and monitoring and a „ready“ evaluation contact are needed. All RAC drive controllers have these connections. They interface via terminal strip X15 (also see Fig. 2.18).

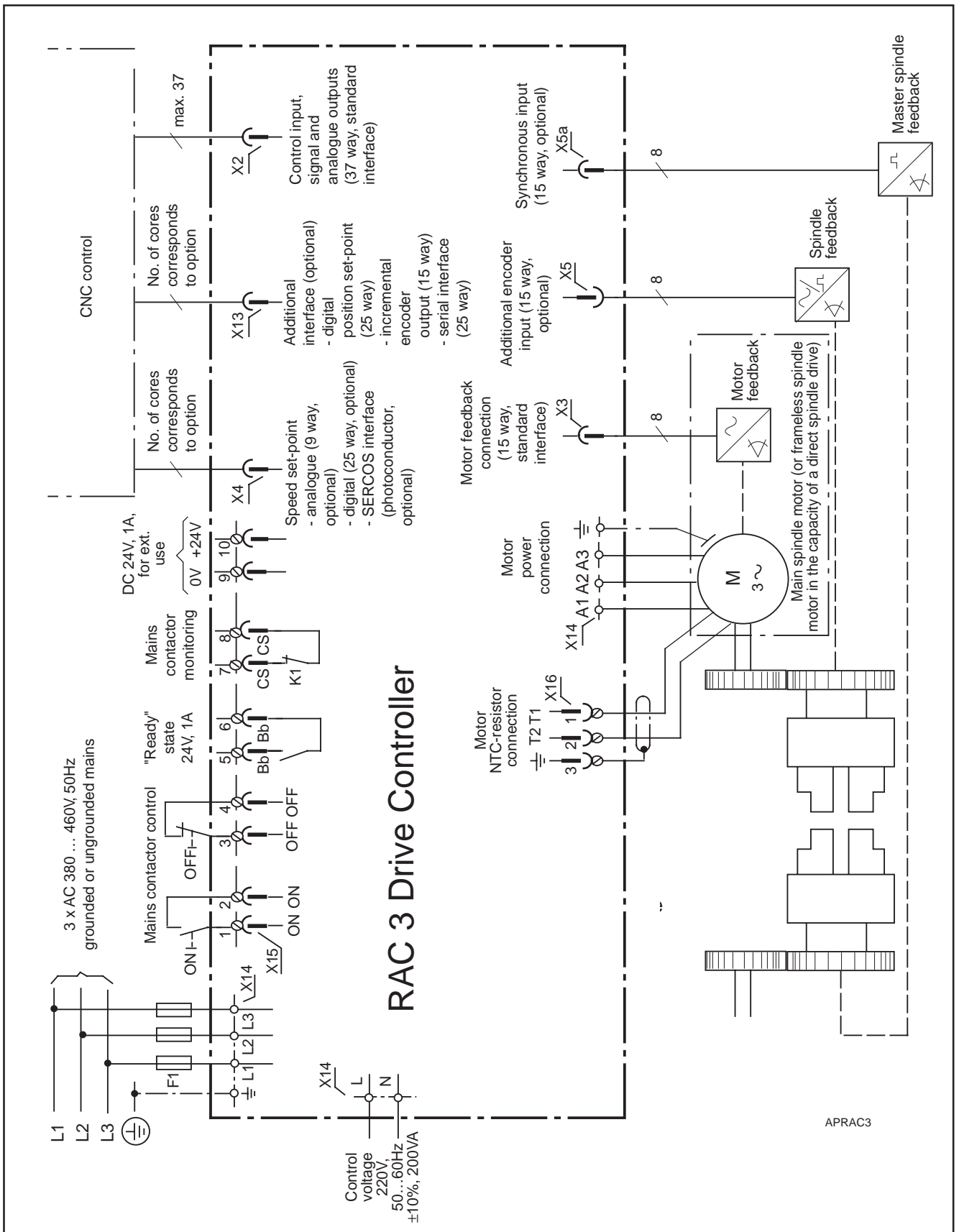

Figure 2.14: Schematic RAC 3 connection diagram

Feedback and CNC connections

All feedback and CNC connection interfaces are identical in terminal assignment and designation regardless of the main spindle controller. They can be found in the document, „Electrical connections of the main spindle drives“ (doc. no. 209-0042-4111), or in „AC main spindle drives with controlled asynchronous motor or frameless spindle motor; description of application“ (doc. no. 209-0041-4109).

Both the functions and signal levels linked to these interfaces are also the same regardless of the main spindle drive controller. They are described in the latter document.

The electrical connections required are dependent upon

- the functional options of the drive controller selected.

Figure 2.16 outlines how the interfaces of each main spindle controller (standard interfaces) are assigned, with the use of a text string, to the corresponding connecting diagram. Figure 2.17 depicts the assigning of the functional options of the drive controller to the corresponding connecting diagram with the use of a text string.

Connecting plans for feedback and CNC connections can be quickly located in the document entitled, „Electrical connections of the main spindle drive; planning and design“, by using the text string (last column of Figs. 2.16 & 2.17). The index of this document lists these text strings.

Designation of type: RAC 3.●-●●●-●●●-●●●-●●●

Standard interfaces	Designation	Connection terminals	Text string
CNC interfaces	Control input signal and analogue outputs	X2, 37-way	IKS 610
Feedback interface	Motor feedback connection	X3, 15-way	IKS 315

see doc.
"Elec. conn. of main spindle drive"

Figure 2.16: Allocation of standard interfaces in the electrical connecting diagrams for feedback and CNC connections

Designation of type: RAC 3.●-●●●-●●●-□□□-●●

Functional options

Circuit diagram see doc. "Elec. conn. of main spindle drives"



Functional options	Codes	Designation	Connection terminals	Text string
 Speed set-point input (type code field 6)	A	analog	X4, 9-way	IKS 613
	D	digital 16 bit-parallel	X4, 25-way	IKS 612
	L	SERCOS-interface	X4, fiber optical cables	IKO
 Additional encoder input (Type codes field 7)	O	without additional encoder input		
	P Y	with additional encoder input	with high-resolution INDRAMAT-encoder (~) X5, 15-way	IKS 312
		Synchronous input	for IKS 327 incremental encoder (┘┘)	X5a, 15-way (┘┘)
 Additional interface (type code field 8)	O	none		
	D	digital position setpoint	X13, 25-way	IKS 612
	I	incremental encoder output	X13, 15-way	IKS 323
	S	RS 232-C serial interface	X13, 25-way	IKS 016

Figure 2.17: Allocation of functional options of drive controller to the electrical connections on the controllers and in the connecting diagram for feedback and CNC connections

Controller-specific connections

There are special plug and socket connectors for integrating the controller into the control circuits of the control cabinet and for the motor NTC-resistor. They are included in the electrical connecting accessories kit E1-RAC.

The electrical connecting accessories consist of the following parts:

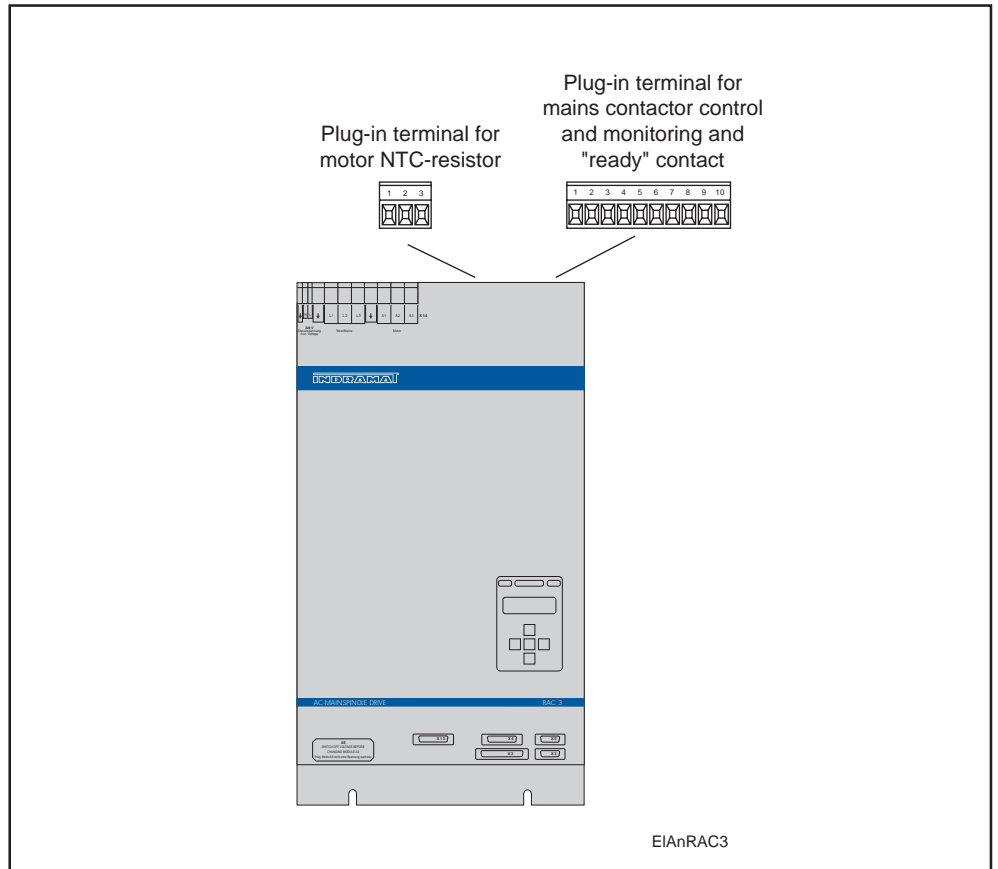

Figure 2.18: Electrical connecting kit E1-RAC

Power connections to the motor

The connection diagrams and the conductor cross sections of the power connections to the motor can be quickly located using the text string (last column of Fig. 2.19) in document: „Electrical connections of the main spindle drives; planning and design“. The index of this document lists these text strings.

The conductor cross sections are dependent upon the rated current of the motor in those drives which permit motor overload for short periods of the duty cycle.

Drive combinations:		RAC 3.●-●●●-●●●-●●●-●●
		with ...
		Circuit diagram, see doc. "Electrical connections of main spindle drives"
...main spindle motor		Text string
2AD 132 B 2AD 132 C 2AD 132 D		2AD 132 connection
2AD160 B		2AD 160 connection
1MB 160 1MB 200 1MB 240 1MB 241 1MB 310 1MB 312		1MB connected to RAC

Figure 2.19: Allocation of main spindle motors to the connection diagram of the power connections

The smaller values can be used for proportioning in the case of those motor controller combinations where the continuous output of the controller is smaller than that of the motor.

See Fig. 2.20, „RAC 3 Technical Data“ for continuous controller currents with different current types.

Power connections to the three-phase supply network

The controllers can be connected to grounded or ungrounded three phase supply networks if the mains voltage and the rated connection voltage of the RAC agree.

The mains connection diagrams for the different networks types are the same for all RAC controllers (RAC 2, RAC3, RAC 4). They are outlined in the document: „Electrical connections for main spindle drives; planning and design“, (doc. no. 209-0042-4111) valid for all main spindle drives. This document lists all data for conductor cross sections, rated fuse currents and any power transformers which might be required.

2.5. Summary of technical data

Designation	Symbol	Unit	RAC 3.1-100		
			RAC 3.1-150		
			RAC 3.5-200		
Cooling			by means of mounted fan		
Rated supply voltage	$U_{(AC)}$	V	3 x AC 380 - 460 V, ± 10%, 50 - 60 Hz		
Control voltage	$U_{(AC)}$	V	AC 230 V, ± 10%, 50 - 60 Hz; 200 VA		
Continuous controller current	$I_{(cont)}$	A	70	92	92
Continuous controller output (with reference to motor output shaft)	$P_{(cont)}$	kW	26	35	35
Continuous output with 8kHz operation (only RAC 3.5)	$P_{(cont)}$	kW	22	30	30
Peak controller output (with reference to motor output shaft)	$P_{(max)}$	kW	26	40	55
Continuous regeneration output (with reference to motor output shaft)	$P_{(reg.)}$	kW	18	27	27
Peak regeneration output (max. 5 sec.) (with reference to motor output shaft)	$P_{(max. reg.)}$	kW	26	40	55
Weights					
Controller weight	m	kg	49		
Weight of accessories M1-RAC 3.1 (hose cooling)	m	kg	1,7		
Environmental conditions					
Perm. ambient temperature range with rated data		°Celsius	+5 ... +45		
Max. perm. ambient temperature with rated data reduced to 80%		°Celsius	+55		
Storage and transportation temperature		°Celsius	-30 ... +85		
Installation altitude without a reduction in rated data		meters above sea level	max. 1000		
Permissible humidity as per humidity class			F as per DIN 40 040		
Protection category			IP 10 as per EN 60 529 (DIN VDE 0470)		

Figure 2.20: The technical data for the RAC 3

2.6. Type codes

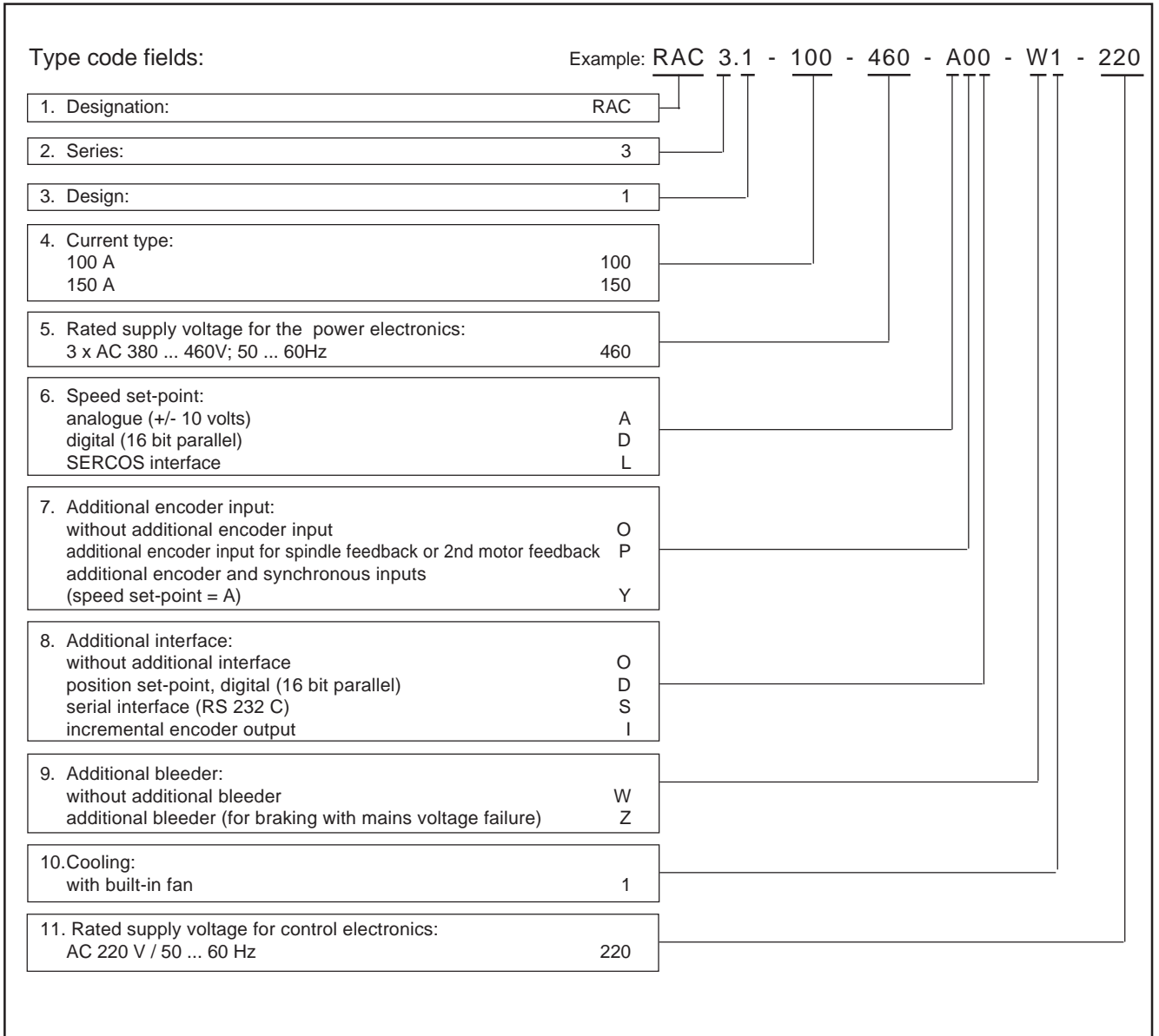

Figure 2.21: RAC 3 type codes

3. AS programming module

The AS programming module plugged into the controller matches the controller to the main spindle motor and implements main spindle drive characteristics.

INDRAMAT supplies a matching AS programming module (standard design as per selection data) for every main spindle drive offered.

INDRAMAT main spindle drives are microprocessor controlled.

Rapid commissioning of drive The main spindle drive is immediately ready at the initial run without any adjustment work being necessary. This is because of the AS programming module. The only prerequisites are proper connecting and proper commissioning (see Section 9).

Parameters can be used to adapt INDRAMAT main spindle drives to plant conditions and the demands of an application.

Advantages of unit exchange Operating software and parameters are stored on the AS programming module. In the event that a unit needs to be exchanged, the controller requires no readjusting as it is immediately adapted to both motor and plant by simply plugging in the programming module thus far used and, therefore, already adapted.

Duplication It is easy to duplicate already adapted programming modules for additional, similar machines. This is done with either a parameter duplicating adapter or with serial interfaces and a storage device (PC or something similar).

Parameters The software has two sets of parameters:

- drive-related, and,
- application-related.

The drive-related parameters affect the operating characteristics of the drive. INDRAMAT defines and fixes the appropriate parameter values to implement the characteristics of the drives offered.

The application-related parameters activate or affect, according to application, the functions of the main spindle drive and adapt them to the reality of the plant.

Parameter value input and change The method of input and making changes in parameter values is the same in all INDRAMAT main spindle drives. The keypad on the control panel of the drive controller is used for this purpose.

For detailed instructions see the Section, „Operating the drive controller“, in the document: „AC main spindle drives with asynchronous motors or frameless spindle motors, description of application“, (doc. no. 209-0041-4109).

3.1. Types of AS programming modules

The AS programming module contains the application-related parameter values as defined by INDRAMAT.

Standard The application-related parameters are preset values. The plant or application-dependent parameter values are stored on site.

The customer is responsible for the documentation and the administration of these facility- and application-dependent parameter values.

Customer-specific (for large series) If INDRAMAT is to document, administer and deliver a programming module after it has been filled with both facility- and application-dependent parameter values, then it is necessary to fix a customer-specific programming module. This is done upon customer request, for an additional fee, and in agreement with INDRAMAT.

3.2. The compatibility of AS programming modules

A state-of-the-art (AS programming module updating) programming module for the operation of the drive is automatically part of the delivery. No change in an order is necessary (type designation). Any updated programming module is compatible with all programming modules already delivered.

Updating AS programming modules It is not necessary to make any changes in a programming module order. There should be no doubt that the drive being operated is state-of-the-art.

This means:

- software fault-recovery,
- an expansion of the range of functions without impairing existing functions,
- and, improved parameter values for motor-controller combinations.

3.3. Rating plate information

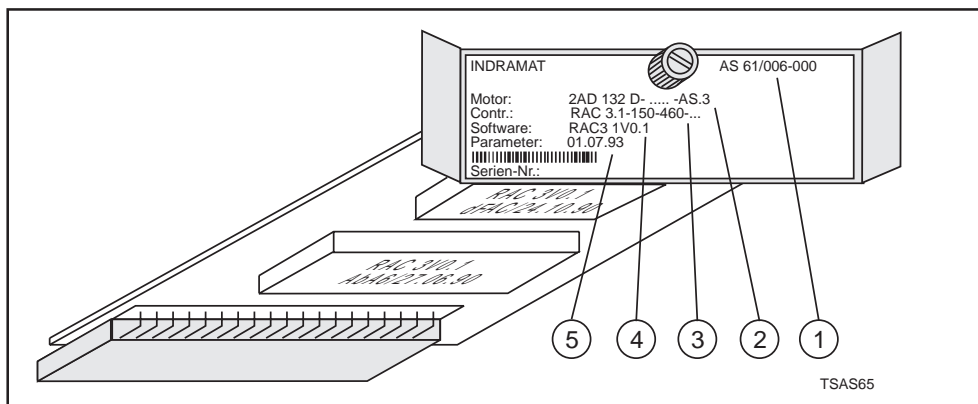

Figure 3.1: AS programming module with type plate information

① Type designation

The final digits of a standard design programming module are -000. Customer-specific programming modules end with the customer-specific numbers fixed by INDRAMAT.

② Motor type information

③ Information on types of drive controllers

The type information for motor and drive controllers found on the programming module must agree with that of the motor and drive controller installed. There is otherwise the risk of damage!

④ Software designation

The letter-number-combination, including the letter „V“, state software type with version. The numbers which follow are the numbers of the software update.

⑤ The date the parameters were fixed

INDRAMAT herewith records the date and status of the technical parameters including the parameter values.

3.4. Type codes

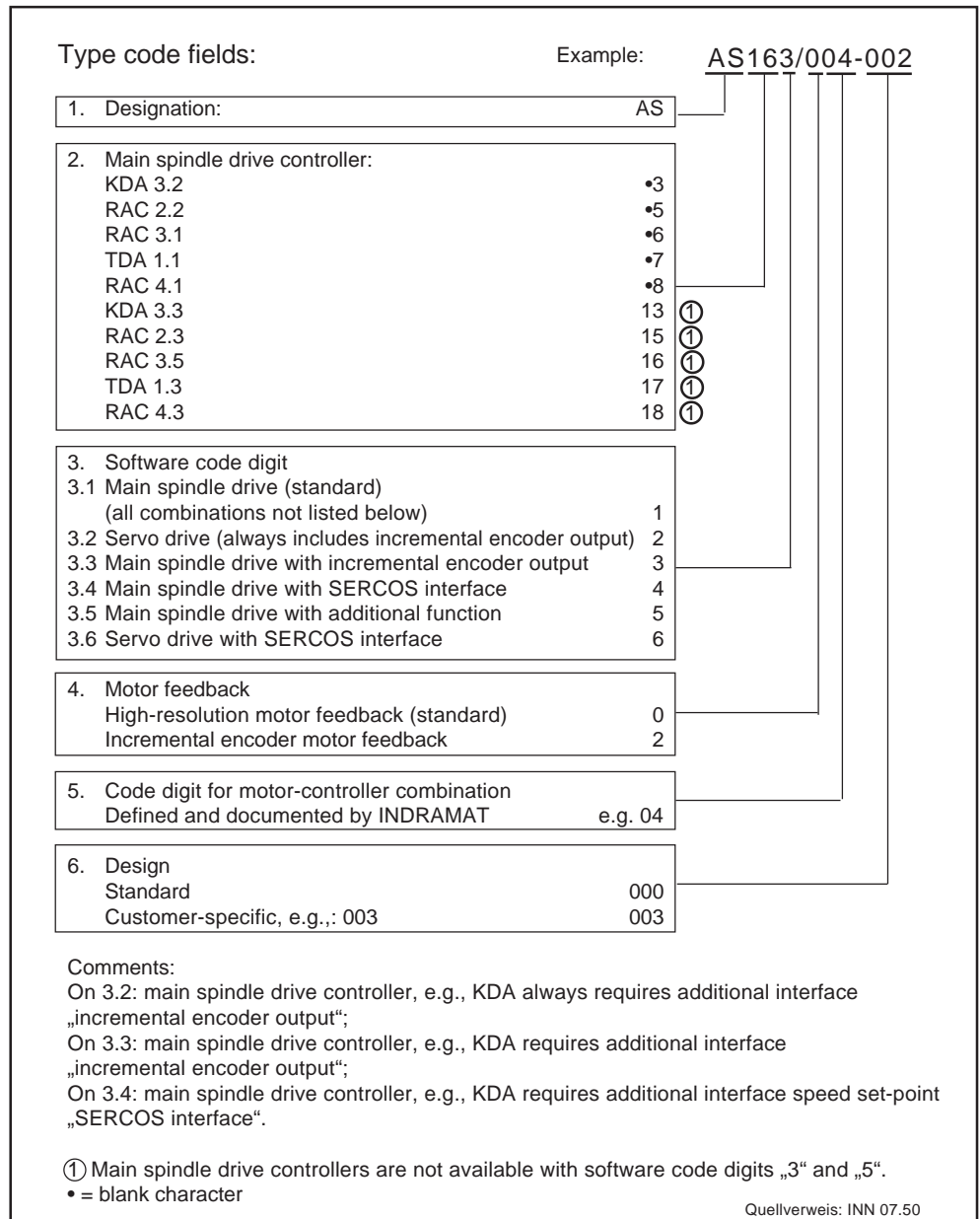

Figure 3.2: Type codes for AS programming modules

4. Condition upon delivery

The RAC 3 with all its accessories comes packed in a carton (transport container) upon delivery. Accessories are packed in plastic bags loosely placed in the carton (possibly M1-RAC3 and E1-RAC).

Covers needed to accommodate the structural alterations when cooling the control cabinet with outside air are packed in one plastic bag and attached to the drive controller.

An envelope containing two delivery slips is attached to the transport container. There are no additional delivery documents unless specifically requested.

Simply split open the glue strips to unpack without damaging the merchandise.

The RAC 3 drive controller is delivered with control cabinet outside air cooling (see Sec. 1). Current and insulation have also been quality controlled as per VDE 0160.

5. Identifying the merchandise

An original and a copy of the delivery slip are attached to the transport container. The parts of the delivery can be packed in several cartons (transport containers). This is noted on the delivery slip, or freight invoice.

The delivery slip lists the merchandise by name and order identification.

The transport container contains the individually packed drive controller and accessories in the case of a mixed order. In the case of multiple orders of the same equipment, the accessories may be in a separate transport container.

*RAC 3 main spindle
drive controller*

There is a barcode sticker on the RAC 3 packaging. It identifies the contents and the order.

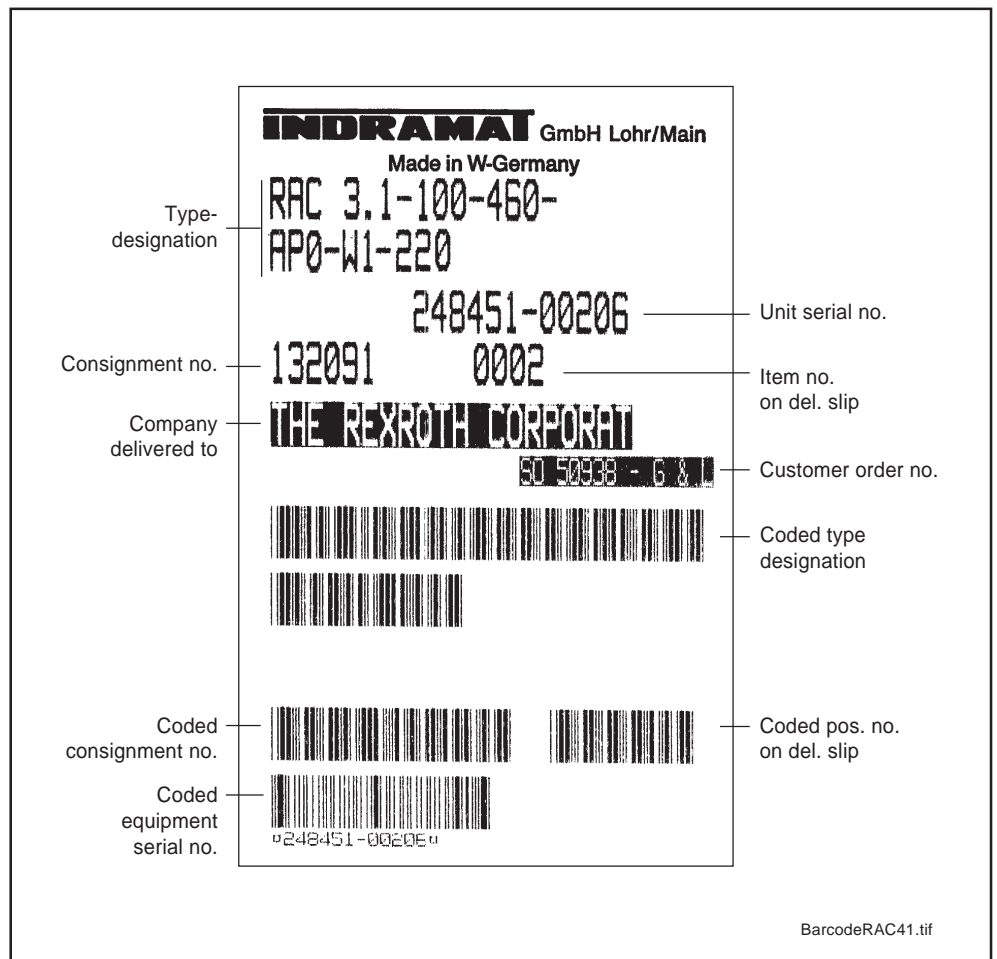

Figure 5.1: Barcode sticker on the RAC packaging (example)

The RAC 3 itself has a sticker on the side which lists all required information. It corresponds to the barcode sticker and lists the delivery date (see Fig. 5.2).

There is a type plate on the lower left hand corner of the RAC 3, inside the housing (see Fig. 5.3).

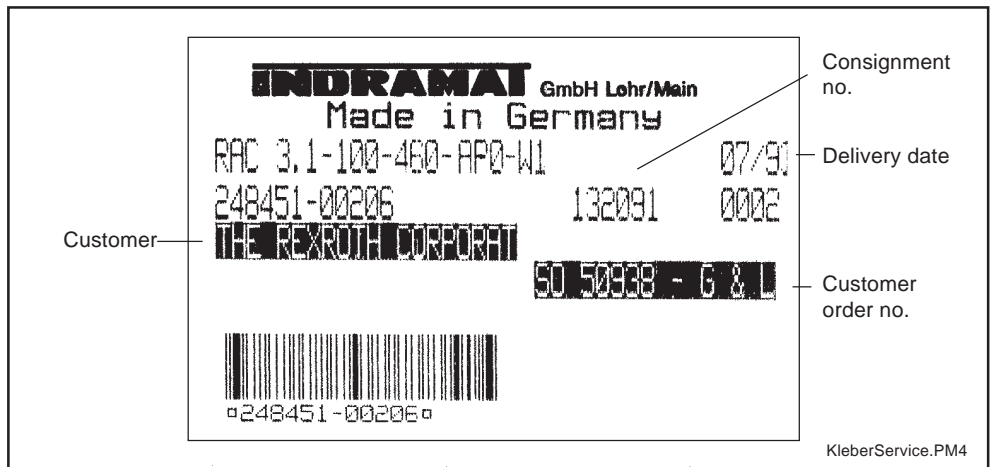

Figure 5.2: Barcode sticker for servicing (on side of unit, example)

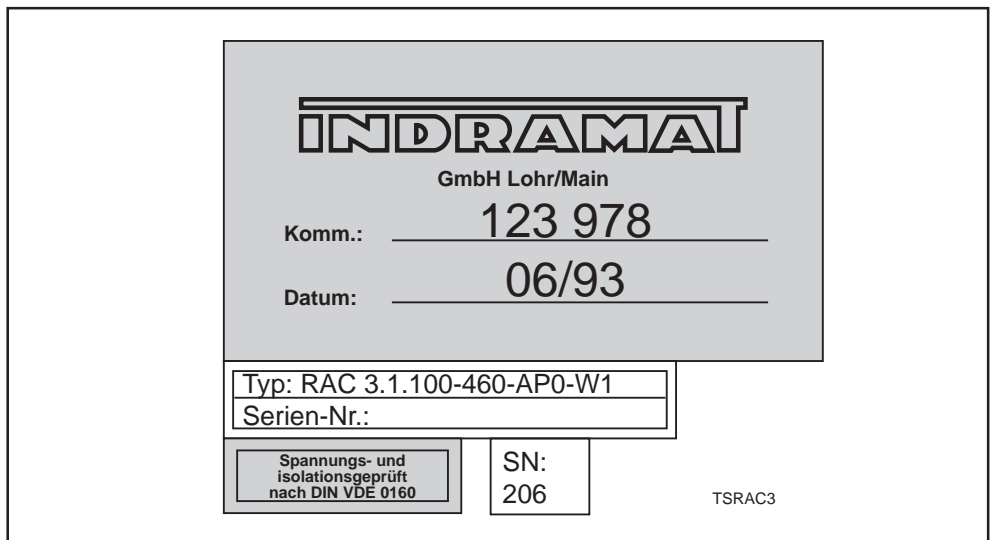

Figure 5.3: RAC 3.1 type plate (on the left inside wall)

AS programming module

Programming modules are always individually packed in plastic bags and then additionally in a carton.

There is a barcode sticker on the carton which additionally renders the information in plain language (Fig. 5.4).

The plastic bag protects the AS programming module against static loads.



Avoid contact with the printed circuit board!

The parameter list is in the plastic bag with the programming module. It documents the parameter values stored upon delivery.

Should parameter values, for example, be lost upon commissioning, then it is possible to manually reload the original values as per the parameter list. The parameter list should be filed with the machine file!

There is a type plate on the front of the programming module (see Fig. 3.1).



Figure 5.4: Barcode sticker on the carton of the programming module

Accessories The electrical accessories are packed in plastic bags with order information written on them.

Mechanical accessories kit M1-RAC 3 (optional hose cooling) is packed in a separate carton. It contains the four flanges (not packed) and all the screws (in one plastic bag) needed for mounting hose cooling. „M1-RAC3“ is written on the outside of the carton. The hose is not part of the delivery!

6. Storage and transportation

The drive controllers must be stored dry, dust and impact-free, permissible temperature range is -30 to +85 degrees C.

Use a vibration-damping base during transportation in the event of the danger of excessive vibrations!

The transportation guidelines found on the packaging:

Achtung Hochwertige Elektronik Attention Fragile Electronic	
Vor Nässe schützen	Nicht werfen
Nicht belasten	Nicht kanten
Do not apply load	Do not tip
Do not drop	Keep dry

Figure 6.1: Safety tips for transportation

7. Assembly

Condition at delivery As a standard, the controller is delivered with a cooling system which uses control cabinet inside air. Should this not agree with the cooling method installed in the machine, then structural changes are necessary. For the sake of expediency, these should be done before the controller is installed in the control cabinet.

Structrual changes to accomodate control cabinet outside air The parts needed are in a plastic bag attached to the RAC drive controller.

- Screw on cover for fan housing (1).
- Screw on cover for heatsink (2).

The installation panel used must have slits must for cooling with control cabinet outside air!

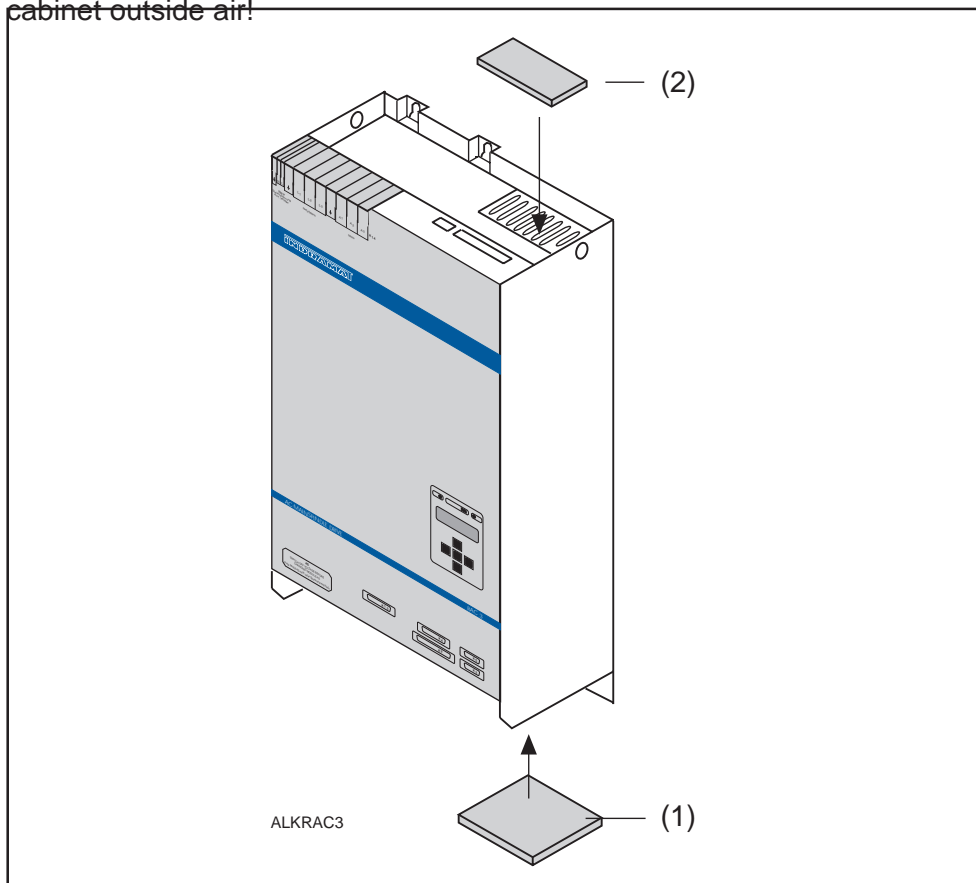

Figure 7.1: Structural changes to accomodate cooling with control cabinet outside air.

*Structural changes
to accommodate hose
cooling*

Install hose cooling accessories (1) as per supplied instructions (drawing no. 9.588.116.3-00).

Use an assembly panel without slits for hose cooling!

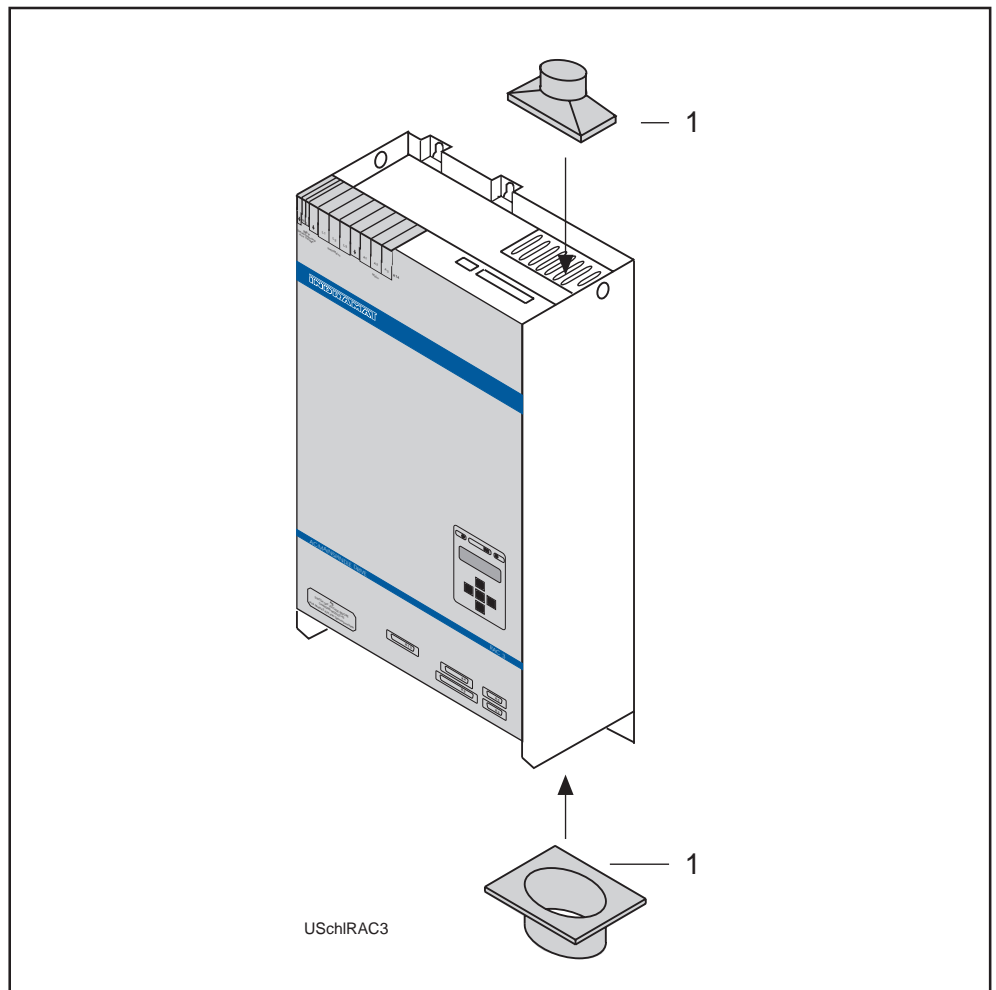

Figure 7.2: Structural changes to accommodate hose cooling

7.1. Installing the drive controller in the control cabinet

The following parts are needed for installation in the control cabinet

- RAC 3 drive controller
- lifting device (RAC 3 weight = 49 kg)

Installing the drive controller

The mounting panel or back wall of the control cabinet has been made ready for the intended type of cooling and is hanging on the screws which are in place. Tighten the screws.

Plug in programming module

The programming module is plugged into the socket located on the lower left hand edge of the front panel of the RAC 3. Insert the programming module and secure it with a knurling screw!



The programming module must be plugged in and secured with a knurling screw before the RAC 3 is commissioned.

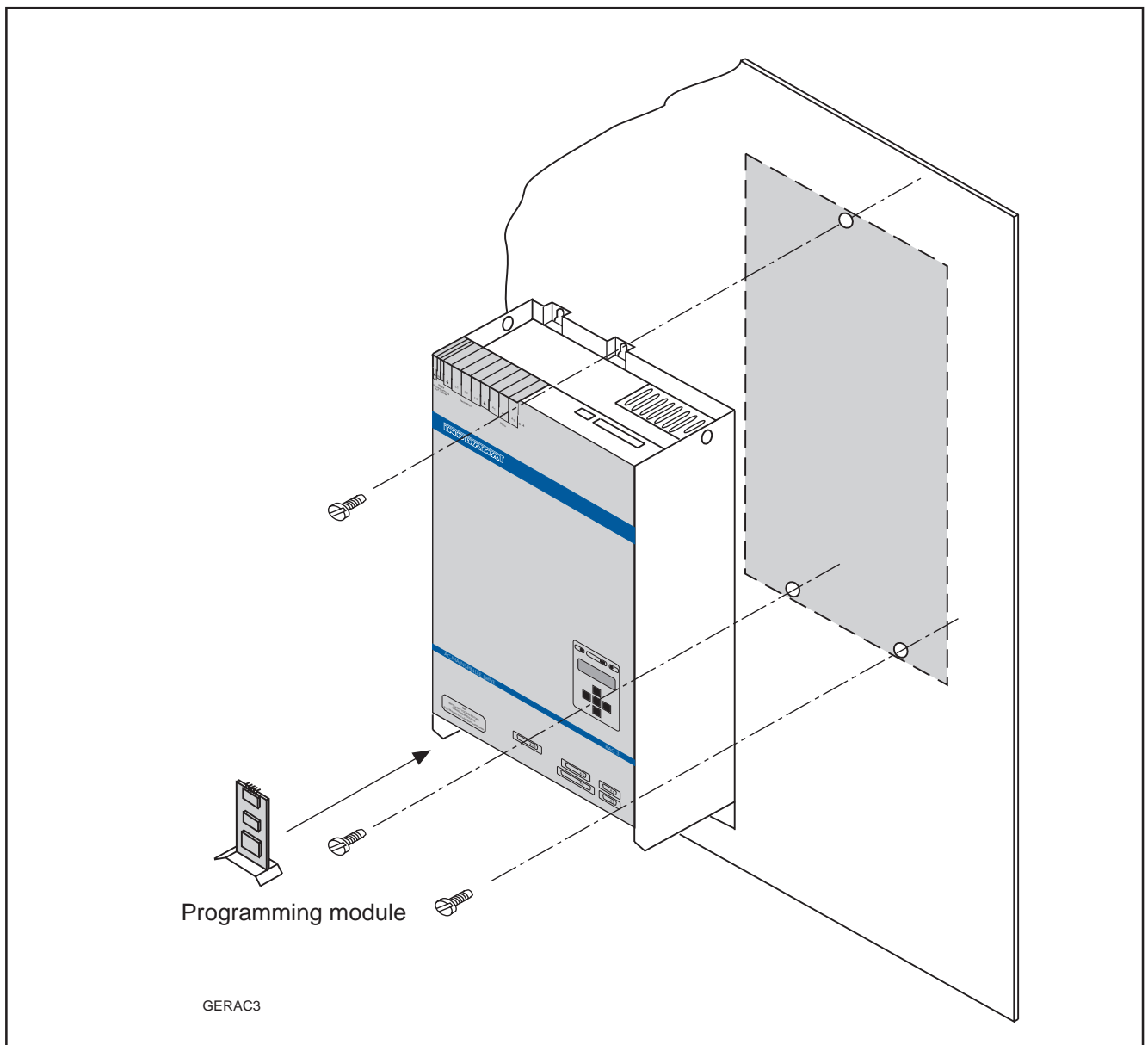

Figure 7.3: Installing the RAC 3

8. Installation guidelines

- The plant connecting diagrams from the manufacturer of the machine should be used when wiring the plant!
- The connecting diagrams from INDRAMAT, see „The electrical connections of main spindle drives; planning and design“ (doc. no. 209-0042-4111) should be used to develop the plant connecting diagrams.
- Mount the safety guard on the front of the unit before turning the unit is on and commissioning it!
- Screw the D-sub-plug and socket connectors firmly into place upon commissioning!
- Twist the power cable cores!
- Ground motor on the controller!

9. Commissioning guidelines

Commissioning is the same for all main spindle drive controllers (RAC 2, RAC 3, RAC 4). For this reason and because of the range of functions, the commissioning guidelines for all INDRAMAT main spindle drives are explained only once in the document entitled „AC main spindle drives with controlled asynchronous motors or frameless spindle motors – description of application“, (doc. no. 209-0041-4109)! The procedure described herein is valid for all controllers.

10. Servicing guidelines

10.1. Fault diagnosis

The RAC 3 diagnosis drive faults via the display on the control panel. The drive brakes until standstill in the presence of a fault. The RAC 3 then cuts power. Fault diagnosis is the same in the different main spindle drive controllers.

For this reason, the fault diagnoses and guidelines on fault recovery are described in the documentation valid for all INDRAMAT main spindle drives entitled: „AC main spindle drives with controlled asynchronous motors or frameless spindle motors – description of application“, (doc. no. 209-0041-4109).

10.2. Defective controller

If an exchange should become necessary, then the drive can be adapted without any difficulty. Simply remove the programming module from the defective unit and then plug it into the replacement unit. The drive with the new controller behaves the same as the original. This is because the drive and machine-specific adaptation of the RAC 3 are realized in the AS programming module.

Should work on the drive controller become necessary because of a defect, then the following procedure must be followed:

- Open the power supply switch and secure it against being switched back on before working on any electrical equipment. The drives must be standing still.

Repairs

- Only INDRAMAT customer service personnel or appropriately trained technical personnel may perform repairs on the unit!

Controller exchange

- Detach and remove all connections for a controller exchange. Detach the fixing screws and take the RAC 3 out of the control cabinet.
- Hang the replacement unit onto the fixing screws and then tighten the screws. Remove the programming module from the defective unit, plug it into the replacement and secure it against falling out by tightening the knurling screws.



Do not remove or plug in the programming module when the unit is live! The fixing screw on the programming module must be tightened prior to commissioning the RAC 3!

- Connect the new RAC 3 as per the plant connecting diagram and mount the safety guard.
- Recommission plant (see documentation „AC main drives with controlled asynchronous motors or frameless spindle motors — description of application“, (doc. no. 209-0041-4109), the section on commissioning.

Returning a defective controller

- Fill out the return card for merchandise return/fault protocol! This return card is depicted in Fig. 10.1 and can be copied for your use and convenience!
- Return defective unit with completed return card to the appropriate INDRAMAT customer service representative.

Repair Card for INDRAMAT equipment and components				
Completed by:		Company/Town:		Date:
When replacing single components, enter component designation		SN:		Supply job no.:
		SN:		Shipment date:
Machine manufacturer/Company:	Type:	Machine no.:	if necessary - commissioning date	
Fault in axis no.	<input type="checkbox"/> horizontal <input type="checkbox"/> vertical <input type="checkbox"/>	Operating hours:	Date fault occurred:	
Fault status: Fault _____ _____ <input type="checkbox"/> always present <input type="checkbox"/> occurs sporadically <input type="checkbox"/> occurs after _____ hrs <input type="checkbox"/> occurs on impact/vibration <input type="checkbox"/> is temperature-dependent <input type="checkbox"/> other * _____ * _____ * _____		Additional information: (e.g. LED diagnosis messages in display) _____ _____ _____ _____ _____ _____ _____		Cause of fault: <input type="checkbox"/> not known <input type="checkbox"/> fault connection <input type="checkbox"/> ext. short-circuit <input type="checkbox"/> mech. damage <input type="checkbox"/> loose cable connections <input type="checkbox"/> other * _____ * _____ * _____
Supplementary information				
General details: <input type="checkbox"/> no function <input type="checkbox"/> drive running irregularly <input type="checkbox"/> uncontrolled drive motion <input type="checkbox"/> fault in only one direction <input type="checkbox"/> burnt-out fuse on supply <input type="checkbox"/> other		Related incidents: <input type="checkbox"/> mechanical problems <input type="checkbox"/> failure of power supply <input type="checkbox"/> failure of controller <input type="checkbox"/> motor failure <input type="checkbox"/> cable break <input type="checkbox"/> other		Controller, supply unit, amplifier, mains power: <input type="checkbox"/> faulty control voltage <input type="checkbox"/> mains power fuse burnt out <input type="checkbox"/> defective fan <input type="checkbox"/> defective bleeder resistor <input type="checkbox"/> faulty power supply voltage <input type="checkbox"/> connection bolt sheared off <input type="checkbox"/> other
Control system: <input type="checkbox"/> no function <input type="checkbox"/> faulty display <input type="checkbox"/> no set-point output <input type="checkbox"/> diagnosis <input type="checkbox"/> dimensional shift in direction <input type="checkbox"/> E-STOP circuit broken <input type="checkbox"/> pos. control loop does not close <input type="checkbox"/> programme sequence fault <input type="checkbox"/> faulty internal auxiliary function (outputs) <input type="checkbox"/> acknowledgements not accepted (inputs) <input type="checkbox"/> other _____ _____ _____		Motor: <input type="checkbox"/> defective thermocouple <input type="checkbox"/> defective brake <input type="checkbox"/> defective fan <input type="checkbox"/> defective feedback <input type="checkbox"/> defective speed encoder signal <input type="checkbox"/> defective BLC signal <input type="checkbox"/> earthing short-circuit <input type="checkbox"/> overheating <input type="checkbox"/> other _____ _____ _____ _____		Remarks: _____ _____ _____ _____ _____ _____

Abb. 10.1: Reparatur-Begleitkarte

11. Index

A

Additional interface 28
additional interfaces 8
Allocation of functional options 28
Allocation of main spindle motors 30
Allocation of standard interfaces 28
ambient humidity 12
ambient temperature 11
AS programming module 33

C

Commissioning guidelines 46
Condition upon delivery 37
Conditions for Bb „ready“, 26
Connecting diagram 24
Connections, mains 27
control circuit 26
control voltage connection 8
Controller exchange 47
Controller-specific connections 24, 29
Cooling with air inside the control cabine 6
Cooling with air outside the control cabine 6

D

Defective controller 47
Dimensional data for hose cooling 19
Dimensions for cooling with air inside the control 17
Dimensions for cooling with air outside of the con 16
Dimensions for hose cooling 18
direct mains connection 8
Drill diagram 15

E

Electrical connecting accessories 29
Electrical data 24
Environmental conditions 11

F

Fault diagnosis 47
Feedback and CNC connections 24
feedback interface 8
Feedback, motor 24
Feedback, motor connection 24
Flange for hose cooling 19

I

Identifying the merchandise 38
Installation altitude 12
Installation guidelines 45
Installing the drive controller 44
interface for CNC control 8
interface for monitoring and control 8

K

keypad 9

M

Main spindle feedback 24
main spindle motor 10
mains connection cable 10
Mains contactor 24
Mains contactor control and monitoring 24
Mains contactor monitoring 24
Mechanical data 14
motor fan cable 10
motor feedback cable 10
motor NTC connection 8
motor power cable 10
motor power connection 8

N

nterface for CNC control 8

O

optional interface 9

P

Plug and socket connectors for NTC resistors and c 29
Power connection to the three-phase supply networ 30
Power connections to the motor 30
Power dissipation 20
Power supply unit 26
Principle circuit diagram 26
Programming module 9

R

RAC 3 installation 44
Repairs 47
Return card 47
Returns 47

S

- Servicing guidelines 47
- Spindle, feedback 24
- Storage and transportation 41
- Structural changes to control cabinet outside air 42
- Structural changes to hose cooling 43
- Synchronous input 27

T

- Technical data 31
- The use of cooling devices in control cabinets 22
- Thermal data 20
- Type codes 32
- Type codes, RAC 3 32
- Type codes, AS programming module 36

W

- Weights 31

12. Supplementary documentation

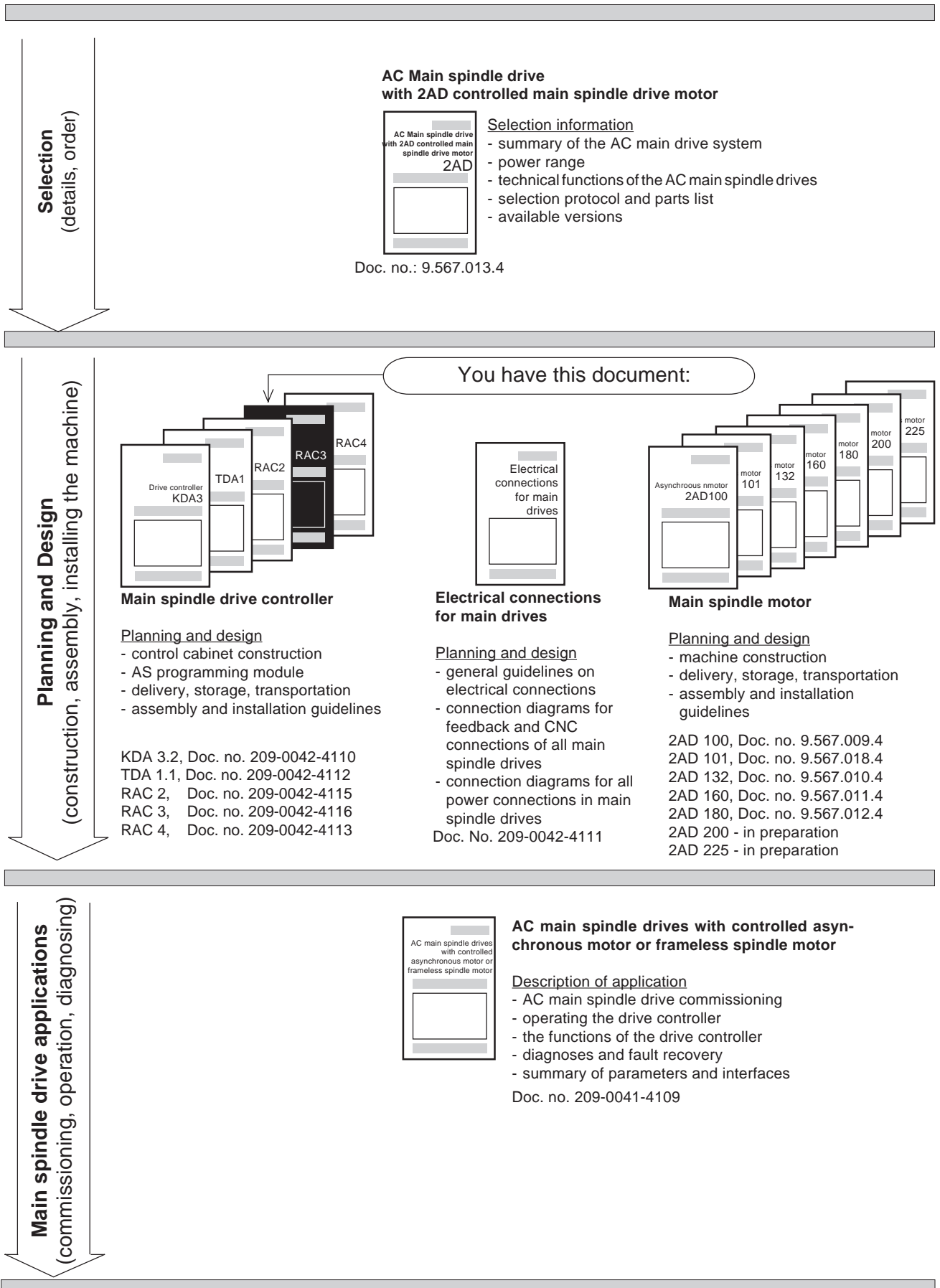
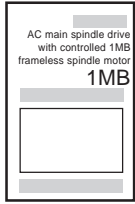

Figure 12.1: Summary of supplementary documentation

AC main spindle drive with controlled 1MB frameless spindle motor



- Selection information
- summary of the AC main spindle drive system
 - power range
 - technical functions of the AC main spindle drive
 - selection protocols and parts lists
 - available versions

Doc. no. 9.567.012.4

AC main spindle drive with 2AD controlled asynchronous motor and 2KB changeover planetary gearboxes

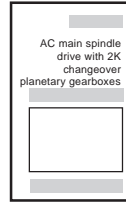

- Selection information
- summary of the AC main drive system
 - power range
 - order guidelines

Doc. no. 9.567.022.4

Selection
(details, order)

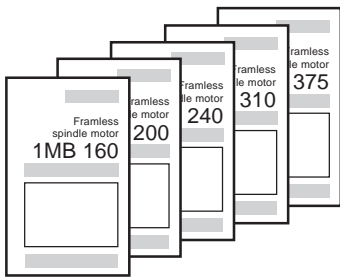

Frameless spindle motor

Planning and design

- machine construction
- integration into the cooling system
- electrical and coolant connections
- delivery

- 1MB 160, Doc. no. 9.576.014.4
- 1MB 200, Doc. no. 9.576.016.4
- 1MB 240/241, Doc. no. 9.576.015.4
- 1MB 310/312, Doc. no. 9.576.008.4
- 1MB 375, Doc. no. 9.576.007.4

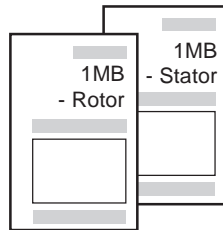

Assembly guidelines

- delivery, handling, transportation
- assembly
- cooling guidelines

- Stator, Doc. no. 9.600.063.4
- Rotor, Doc. no. 9.600.062.4

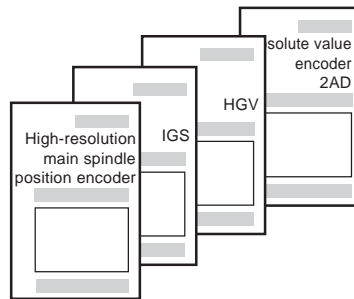

Summary documentation

- high-resolution main spindle position encoder
 - planning and design doc. no. 209-0042-4119
- IGS incremental encoder output doc. no. 9.568.015.4
- HG high-resolution encoder junction doc. no. 9.568.010.4
- Absolute value encoder attachment for 2AD 132, 2AD 160, 2AD 180 doc. no. 9.568.020.4

Planning and Design
(construction, assembly, installing the machine)

Main spindle drive applications
(commissioning, operation, diagnosing)

