



Intel[®] Pentium[®] III Processor Specification Update

Release Date: August 2007

Document Number: 244453-058

The Pentium[®] III processor may contain design defects or errors known as errata which may cause the product to deviate from published specifications. Current characterized errata are documented in this Specification Update.



INFORMATION IN THIS DOCUMENT IS PROVIDED IN CONNECTION WITH INTEL® PRODUCTS. NO LICENSE, EXPRESS OR IMPLIED, BY ESTOPPEL OR OTHERWISE, TO ANY INTELLECTUAL PROPERTY RIGHTS IS GRANTED BY THIS DOCUMENT. EXCEPT AS PROVIDED IN INTEL'S TERMS AND CONDITIONS OF SALE FOR SUCH PRODUCTS, INTEL ASSUMES NO LIABILITY WHATSOEVER, AND INTEL DISCLAIMS ANY EXPRESS OR IMPLIED WARRANTY, RELATING TO SALE AND/OR USE OF INTEL PRODUCTS INCLUDING LIABILITY OR WARRANTIES RELATING TO FITNESS FOR A PARTICULAR PURPOSE, MERCHANTABILITY, OR INFRINGEMENT OF ANY PATENT, COPYRIGHT OR OTHER INTELLECTUAL PROPERTY RIGHT. Intel products are not intended for use in medical, life saving, or life sustaining applications.

Intel may make changes to specifications and product descriptions at any time, without notice.

Designers must not rely on the absence or characteristics of any features or instructions marked "reserved" or "undefined." Intel reserves these for future definition and shall have no responsibility whatsoever for conflicts or incompatibilities arising from future changes to them.

The Intel® Pentium® III processor may contain design defects or errors known as errata which may cause the product to deviate from published specifications. Current characterized errata are available on request.

Contact your local Intel sales office or your distributor to obtain the latest specifications and before placing your product order.

Intel, Pentium, Intel Xeon, Celeron, MMX and the Intel logo are trademarks or registered trademarks of Intel Corporation or its subsidiaries in the United States and other countries.

*Other names and brands may be claimed as the property of others.

Copyright © 1999- 2007, Intel Corporation.



CONTENTS

REVISION HISTORY	ii
PREFACE	vi
GENERAL INFORMATION.....	1
<i>Pentium® III Processor and Boxed Pentium® III Processor Markings</i>	1
<i>Pentium® III Processor Markings</i>	1
IDENTIFICATION INFORMATION	3
<i>Mixed Steppings in DP Systems</i>	4
SUMMARY OF CHANGES	22
ERRATA.....	31
DOCUMENTATION CHANGES	79
SPECIFICATION CLARIFICATIONS.....	80
SPECIFICATION CHANGES.....	83

REVISION HISTORY

Date of Revision	Version	Description
March 1999	-001	This is the first Specification Update for Pentium® III processors.
April 1999	-002	Added Erratum E42. Deleted Erratum E16 and renumbered existing items. Corrected Errata table "Plans" column for E39. Updated the Pentium III Processor Identification Information table.
May 1999	-003	Updated the Pentium III Processor Identification Information table. Updated the Errata table by marking Errata E34, E35, and E40 as Fixed.
June 1999	-004	Updated the Pentium III Processor Identification and Package Information table. Added Erratum 43. Added Documentation Change E1. Added Specification Clarifications E1 and E2. Added Specification Change E3.
July 1999	-005	Added footnote 4 to the Pentium III Processor Identification and Package Information table. Added Erratum E44. Added stepping Kc0 in Summary Table of Changes. Added Mixed Steppings in DP Systems section. Updated Documentation Changes, Specification Clarifications, and Specification Changes introduction paragraphs.
August 1999	-006	Added Errata E45 and E46. Added Documentation Change E2. Updated Identification Information table. Updated and corrected Pentium III Processor Identification and Package Information table. Updated Codes Used in Summary Table. Updated column heading in Errata, Documentation Changes, Specification Clarifications and Specification Changes tables.
September 1999	-007	Revised Errata E45. Updated DP Platform Population Matrix for the Pentium III Processor with 100 MHz System Bus. Updated datasheet references to include the latest supported frequency.
October 1999	-008	Added Errata E47. Updated the Pentium III Processor Identification and Package Information table. Added the DP Platform Population Matrix for the Pentium III Processor with 133 MHz System Bus table. Added Brand ID column to Identification Information. Updated datasheet references to include the latest supported frequency.
November 1999	-009	Added Errata E48 and E49. Added Documentation Change E3. Added new stepping column in the Summary of Changes tables. Updated the Pentium® III Processor Identification Information tables. Updated Mixed Steppings in DP System section. Updated the Pentium® III Process Identification Information table. Updated references.
December 1999	-010	Updated document references in Preface to include new Pentium III processor datasheets. Updated errata E10, E11, E19, and E32 in the Summary of Errata table. Added Errata E50-E58. Added Documentation Change E4. Added Specification Clarification E3. Added Specification Changes E4 and E5.

**REVISION HISTORY**

Date of Revision	Version	Description
December 1999	-011	Corrected an error in the Summary of Errata table. Erratum E56 was incorrectly shown as applying to the Ca2 stepping. Erratum E56 does NOT apply to the Ca2 stepping.
January 2000	-012	Updated Preface to include new Pentium III processor datasheets. Added 800-MHz Pentium III processor information to the DP Platform Population Matrix tables and the Pentium® III Processor Identification and Packaging Information table. Added note 10 to the Pentium® III Processor Identification and Packaging Information table and updated Notes column and other table data. Updated erratum E51. Added Errata E59-E62. Added Documentation Change E5. Added Specification Change E6.
February 2000	-013	Updated Errata E49 and E61. Added Documentation Change E6. Updated the Pentium® III Processor Identification Information. Updated S-Spec SL365. Updated Summary of Changes product letter codes.
March 2000	-014	Updated Preface to include new Pentium III processor datasheet. Updated Pentium® III Processor Identification and Package Information table. Updated Summary of Errata, Summary of Documentation Changes, Summary of Specification Clarifications Summary of Specification Changes tables with Cb0 stepping. Updated Erratum E48.
March 2000	-015	Special Launch Edition: Updated the new Cb0 stepping information. Updated the document references in the Preface. Updated DP population table.
April 2000	-016	Updated Processor Identification Information table. Updated DP Population Tables. Added Errata E63 & E64.
May 2000	-017	Updated Pentium III Processor Identification and Package Information table. Updated Errata E64. Added Errata E65 & E66.
June 2000	-018	Updated Processor Identification, Summary of Errata, and Summary of Specification Changes tables. Updated Dual Processor Tables. Added new Specification Change E7.
July 2000	-019	Added new errata E67 & E68. Updated Processor Identification Table. Edited erratum E36. Updated Processor Identification, Summary of Errata, Summary of Documentation Changes, Summary of Specification Clarifications, Summary of Specification Changes tables with cC0 Stepping.
August 2000	-020	Added new Erratum E69. Updated Dual Processor Matrix. Updated Dual Processor Matrix. Updated Processor Identification Table with new C0 step CPUs.
September 2000	-021	Added New Errata E70 & E71. Added Re-Writes for Errata E28, E48, & E62. Added New Documentation Changes E7 & E8. Updated Dual Processor Matrix, removed TBDs. Updated Processor Identification Table.
October 2000	-022	Updated Pentium® III Processor Identification Information table. Updated Dual Processor Matrix. Added New Errata E72 and E73.

REVISION HISTORY

Date of Revision	Version	Description
		Added New Documentation Changes E9 and E10.
November 2000	-023	Updated Processor Identification Table. Added New Erratum E73.
December 2000	-024	Updated Specification Update product key to include the Intel® Pentium® 4 processor, Revised Erratum E2. Added new Documentation Changes E11 – E16.
January 2001	-025	Revised Erratum E2. Added new Documentation Changes E17 and E18. Updated Processor Identification Table.
February 2001	-026	Added new Documentation Change E19. Revised Documentation Change E17.
March 2001	-027	Added new Errata E74 and E75.
March 2001	-028	Added erratum E76
May 2001	-029	Revised Erratum E76 to Fixed. Updated processor identification table. Updated the tables in the Mixed Steppings in DP Systems section.
June 2001	-030	Updated note 18 in the Pentium® III Processor Identification and Package Information table. Updated Specification Update product key to include the Intel® Xeon™ processor
June 2001	-031	Special Launch Edition: Added package marking information under General Section. Added new S spec info into processor table. Updated Dual Processor tables. Updated Summary of Errata, Summary of Documentation, Summary of Specification Clarifications, and Summary of Changes tables. Added Errata E77 & E78.
July 2001	-032	Added new S spec info into processor table. Revised package marking information under General Section. Updated Dual Processor tables. Deleted duplicate information in the processor ID table.
August 2001	-033	Added new errata E79 and E80. Updated DP Matrix Tables
October 2001	-034	Changed word “motherboard” to “baseboard” in erratum E78
November 2001	-035	Updated DP population matrix for new tA1 parts. Added Doc Changes E20, E21, E22, E23, and E24.
November 2001	-036	Special launch edition. Added part with S-Spec SL5VX at 1.33GHz to the Pentium® III Processor Identification and Package Information list.
February 2002	-037	Added: Doc changes E25, E26, E27, E28, E29, Spec Clarification E4, E5 and Spec Change E8. Added part with S-Spec SL657 to the Processor ID Information Table
March 2002	-038	Modified Erratum E80 and added Erratum E81. Added Doc Change E1.
March 2002	-039	Out of Cycle Special Launch Edition. Added Server LV part with S-Spec Number SL66D at 800 MHz to the Pentium® III Processor Identification and Package Information list.

**REVISION HISTORY**

Date of Revision	Version	Description
April 2002	-040	Added Doc Change E1.
May 2002	-041	Modified Errata E59. Added Doc Changes E1, E2, and E3.
June 2002	-042	Added Erratum E82. Added Doc Changes E1 and E2. Added parts with S-Spec numbers SL6C2, SL6C3, SL6C4 and SL6BZ with Core Stepping tB1 to the Processor ID Information Table.
July 2002	-043	Added Document Changes E3-E12. Added parts with S-Spec numbers SL6BW, SL6BX, SL6BY and SL6HC with Core Stepping tB1 to the Processor ID Information Table. Changed status of erratum E78 to NOFIX.
September 2002	-044	Added new Doc Changes E3-E24. Removed parts with S-Spec numbers SL6C2, SL6C3, SL6C4 and SL6BZ with Core Stepping tB1 from the Processor ID Information Table.
October 2002	-045	Added Doc Changes E25 to E32. Updated Summary of Changes.
December 2002	-046	Updated DP FC-PGA2 Matrix table. Added one S-spec number.
March 2003	-047	Added Erratum E83.
May 2003	-048	Updated Summary of Errata table E78 and Added one S Spec number.
November 2003	-049	Added Errata E84 and E85.
October 2004	-050	Updated E85 and added E86 to E89
November 2004	-051	Added Errata E90, E91, E92
February 2005	-052	Added Errata E93, E94
March 2005	-053	Updated Errata E80
April 2005	-054	Added Specification Clarification
December 2005	-055	Added Errata E95, E96, E97, E98, E99, E100, E101, E102, E103, E104, E105, E106, E107. Updated Summary Table of Changes. Updated the name of the Software Developer Manuals.
January 2007	-056	Added Erratum E108
May 2007	-057	Updated Summary Table of Changes.
August 2007	-058	Added Erratum E109. Updated Summary Table of Changes.

PREFACE

This document is an update to the specifications contained in the following documents:

- *Pentium® III Processor for the SC242 at 450 MHz to 1.13 GHz* datasheet (Order Number 244452)
- *Pentium® III Processor for the PGA370 Socket up to 1.13 GHz* datasheet (Order Number 245264)
- *Intel Architecture Software Developer's Manual, Volumes 1, 2a, 2b, 3a and 3b* (Order Numbers 253665, 253666, 253667, 253668, and 253669 respectively)

It is intended for hardware system manufacturers and software developers of applications, operating systems, or tools. It contains S-Specs, Errata, Documentation Changes, Specification Clarifications, and Specification Changes.

Nomenclature

S-Spec Number is a five-digit code used to identify products. Products are differentiated by their unique characteristics, e.g., core speed, L2 cache size, package type, etc., as described in the processor identification information table. Care should be taken to read all notes associated with each S-Spec number.

Errata are design defects or errors. Errata may cause the Pentium III processor's behavior to deviate from published specifications. Hardware and software designed to be used with any given processor must assume that all errata documented for that processor are present on all devices unless otherwise noted.

Documentation Changes include typos, errors, or omissions from the current published specifications. These changes will be incorporated in the next release of the specifications.

Specification Clarifications describe a specification in greater detail or further highlight a specification's impact to a complex design situation. These clarifications will be incorporated in the next release of the specifications.

Specification Changes are modifications to the current published specifications for the Pentium III processor. These changes will be incorporated in the next release of the appropriate documentation(s).

GENERAL INFORMATION

Pentium® III Processor and Boxed Pentium® III Processor Markings

Dynamic Mark Area

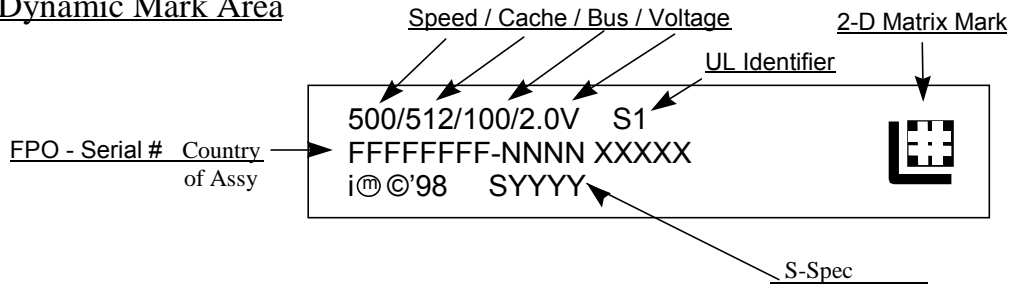

Pentium® III Processor Markings

SECC2/Slot 1 Package

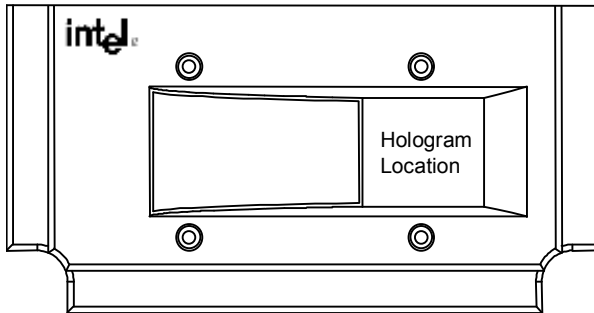

FC-PGA 370 Pin Package

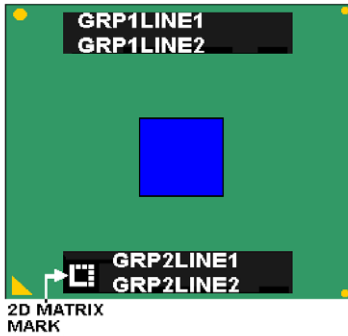

GRP1LN1: INTEL (m)(c) '01_-_{COO}
GRP1LN2: {Speed}/{Cache}/{Bus}/{Voltage}

GRP2LN1: {FPO}-{S/N}
GRP2LN2: PENTIUM III {S-Spec}

FC-PGA2 370 Pin Package

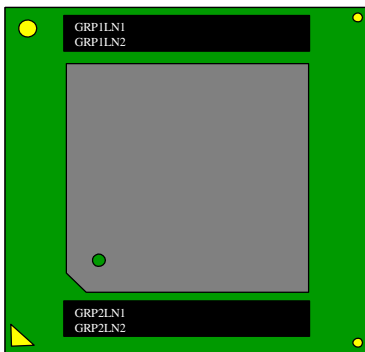

GRP1LN1: INTEL (m)(c) '01_-_{Country of Origin}
GRP1LN2: {Core freq}/{Cache}/{Bus Freq}/{Voltage}

GRP2LN1: {FPO}-{S/N}
GRP2LN2: PENTIUM III {S-Spec} or PENTIUM III-S {S-Spec}

Note: S above applies to 06BxH 512KB cache processor



IDENTIFICATION INFORMATION

The Pentium® III processor can be identified by the following values:

Family ¹	Model ²	Brand ID ³
0110	0111	00h = Not Supported
0110	1000	02h = "Intel® Pentium® III Processor"

NOTES:

1. The Family corresponds to bits [11:8] of the EDX register after RESET, bits [11:8] of the EAX register after the CPUID instruction is executed with a 1 in the EAX register, and the generation field of the Device ID register accessible through Boundary Scan.
2. The Model corresponds to bits [7:4] of the EDX register after RESET, bits [7:4] of the EAX register after the CPUID instruction is executed with a 1 in the EAX register, and the model field of the Device ID register accessible through Boundary Scan.
3. The Brand ID corresponds to bits [7:0] of the EBX register after the CPUID instruction is executed with a 1 in the EAX register.

The Pentium III processor's second level (L2) cache size can be determined by the following register contents:

512-Kbyte Unified L2 Cache¹	43h
256-Kbyte 8 way set associative 32byte line size, L2 Cache¹	82h
512-Kbyte 8 way set associative 32byte line size, L2 Cache¹	83h

NOTE:

1. For the Pentium III processor, the unified L2 cache size corresponds to a token in the EDX register after the CPUID instruction is executed with a 2 in the EAX register. Other Intel microprocessor models or families may move this information to other bit positions or otherwise reformat the result returned by this instruction; generic code should parse the resulting token stream according to the definition of the CPUID instruction.



Mixed Steppings in DP Systems

Intel Corporation fully supports mixed steppings of Pentium III processors. The following list and processor matrix describes the requirements to support mixed steppings:

- Mixed steppings are only supported with processors that have identical family and model number as indicated by the CPUID instruction.
- While Intel has done nothing to specifically prevent processors operating at differing frequencies from functioning within a multiprocessor system, there may be uncharacterized errata that exist in such configurations. Intel does not support such configurations. In mixed stepping systems, all processors must operate at identical frequencies (i.e., the highest frequency rating commonly supported by all processors).
- While there are no known issues associated with the mixing of processors with differing cache sizes in a dual processor system, and Intel has done nothing to specifically prevent such system configurations from operating, Intel does not support such configurations since there may be uncharacterized errata that exist. In dual processor systems, all processors must be of the same cache size.
- While Intel believes that certain customers may wish to perform validation of system configurations with mixed frequency or cache sizes, and that those efforts are an acceptable option to our customers, customers would be fully responsible for the validation of such configurations.
- The workarounds identified in this and following specification updates must be properly applied to each processor in the system. Certain errata are specific to the dual processor environment and are identified in the *Mixed Stepping Processor Matrix* found at the end of this section. Errata for all processor steppings will affect system performance if not properly worked around. Also see the "Pentium® III Processor Identification and Package Information" table for additional details on which processors are affected by specific errata.
 - In dual processor systems, the processor with the lowest feature-set, as determined by the CPUID Feature Bytes, must be the Bootstrap Processor (BSP). In the event of a tie in feature-set, the tie should be resolved by selecting the BSP as the processor with the lowest stepping as determined by the CPUID instruction.

In the following processor matrix a number indicates that a known issue has been identified as listed in the table following the matrix. A dual processor system using mixed processor steppings must assure that errata are addressed appropriately for each processor.



PENTIUM® III PROCESSOR SPECIFICATION UPDATE

DP Platform Population Matrix for the Pentium® III Processor with 100-MHz System Bus in the SECC and SECC2 Packages

Pentium® III Processor Stepping	450 MHz kB0	500 MHz kB0	450 MHz kC0	500 MHz kC0	550 MHz kC0	600 MHz kC0	600E MHz cA2	650 MHz cA2	700 MHz cA2	750 MHz cA2	800 MHz cA2	550E MHz cB0	600E MHz cB0	650 MHz cB0	700 MHz cB0	750 MHz cB0	800 MHz cB0	850 MHz cB0	600E MHz cC0	650 MHz cC0	700 MHz cC0	750 MHz cC0	800 MHz cC0	850 MHz cC0	1 GHz cC0
450-MHz kB0	NI	X	NI	X	X	X	X	X	X	X	X	X	X	X	X	X	X	X	X	X	X	X	X	X	X
500-MHz kB0	X	NI	X	NI	X	X	X	X	X	X	X	X	X	X	X	X	X	X	X	X	X	X	X	X	X
450-MHz kC0	NI	X	NI	X	X	X	X	X	X	X	X	X	X	X	X	X	X	X	X	X	X	X	X	X	X
500-MHz kC0	X	NI	X	NI	X	X	X	X	X	X	X	X	X	X	X	X	X	X	X	X	X	X	X	X	X
550-MHz kC0	X	X	X	X	NI	X	X	X	X	X	X	X	X	X	X	X	X	X	X	X	X	X	X	X	X
600-MHz kC0	X	X	X	X	X	NI	X	X	X	X	X	X	X	X	X	X	X	X	X	X	X	X	X	X	X
600E-MHz cA2	X	X	X	X	X	X	NI	X	X	X	X	X	NI	X	X	X	X	X	NI	X	X	X	X	X	X
650-MHz cA2	X	X	X	X	X	X	X	NI	X	X	X	X	X	NI	X	X	X	X	X	NI	X	X	X	X	X
700-MHz cA2	X	X	X	X	X	X	X	X	NI	X	X	X	X	X	NI	X	X	X	X	X	NI	X	X	X	X
750-MHz cA2	X	X	X	X	X	X	X	X	X	NI	X	X	X	X	X	NI	X	X	X	X	X	X	NI	X	X
800 MHz cA2	X	X	X	X	X	X	X	X	X	X	NI	X	X	X	X	X	NI	X	X	X	X	X	X	NI	X
550E MHz cB0	X	X	X	X	X	X	X	X	X	X	X	NI	X	X	X	X	X	X	X	X	X	X	X	X	X
600E MHz cB0	X	X	X	X	X	X	NI	X	X	X	X	X	NI	X	X	X	X	X	NI	X	X	X	X	X	X
650 MHz cB0	X	X	X	X	X	X	X	NI	X	X	X	X	X	NI	X	X	X	X	X	NI	X	X	X	X	X
700 MHz cB0	X	X	X	X	X	X	X	X	NI	X	X	X	X	X	NI	X	X	X	X	X	NI	X	X	X	X
750 MHz cB0	X	X	X	X	X	X	X	X	X	NI	X	X	X	X	X	NI	X	X	X	X	X	NI	X	X	X
800 MHz cB0	X	X	X	X	X	X	X	X	X	X	NI	X	X	X	X	X	NI	X	X	X	X	X	X	NI	X
850 MHz cB0	X	X	X	X	X	X	X	X	X	X	X	X	X	X	X	X	X	X	NI	X	X	X	X	X	NI
600E-MHz cC0	X	X	X	X	X	X	NI	X	X	X	X	X	NI	X	X	X	X	X	NI	X	X	X	X	X	X
650 MHz cC0	X	X	X	X	X	X	X	NI	X	X	X	X	X	NI	X	X	X	X	X	NI	X	X	X	X	X
700 MHz cC0	X	X	X	X	X	X	X	X	NI	X	X	X	X	X	NI	X	X	X	X	X	NI	X	X	X	X
750-MHz cC0	X	X	X	X	X	X	X	X	X	NI	X	X	X	X	X	NI	X	X	X	X	X	NI	X	X	X
800 MHz cC0	X	X	X	X	X	X	X	X	X	X	NI	X	X	X	X	X	NI	X	X	X	X	X	X	NI	X
850 MHz cC0	X	X	X	X	X	X	X	X	X	X	X	X	X	X	X	X	X	X	NI	X	X	X	X	X	NI
1 GHz cC0	X	X	X	X	X	X	X	X	X	X	X	X	X	X	X	X	X	X	X	X	X	X	X	X	NI

Notes:

- X= Mixing processors at different frequencies is not supported. This stepping/frequency not supported in DP.
- NI= Currently no known issues associated with mixing these steppings.



DP Platform Population Matrix for the Pentium® III Processor with 133-MHz System Bus in the SECC and SECC2 Package from 533MHz to 733MHz

Pentium® III Processor Stepping	533B MHz kB0	533B MHz kC0	600B MHz kC0	533EB MHz cA2	600EB MHz cA2	667 MHz cA2	733 MHz cA2	533EB MHz cB0	600EB MHz cB0	667 MHz cB0	733 MHz cB0	600EB MHz cC0	667 MHz cC0	733 MHz cC0
533B-MHz kB0	NI	NI	X	X	X	X	X	X	X	X	X	X	X	X
533B-MHz kC0	NI	NI	X	X	X	X	X	X	X	X	X	X	X	X
600B-MHz kC0	X	X	NI	X	X	X	X	X	X	X	X	X	X	X
533EB-MHz cA2	X	X	X	NI	X	X	X	NI	X	X	X	X	X	X
600EB-MHz cA2	X	X	X	X	NI	X	X	X	NI	X	X	NI	X	X
667-MHz cA2	X	X	X	X	X	NI	X	X	X	NI	X	X	NI	X
733-MHz cA2	X	X	X	X	X	X	NI	X	X	X	NI	X	X	NI
533EB MHz cB0	X	X	X	NI	X	X	X	NI	X	X	X	X	X	X
600EB MHz cB0	X	X	X	X	NI	X	X	X	NI	X	X	NI	X	X
667 MHz cB0	X	X	X	X	X	NI	X	X	X	NI	X	X	NI	X
733 MHz cB0	X	X	X	X	X	X	NI	X	X	X	NI	X	X	NI
600EB-MHz cC0	X	X	X	X	NI	X	X	X	NI	X	X	NI	X	X
667-MHz cC0	X	X	X	X	X	NI	X	X	X	NI	X	X	NI	X
733-MHz cC0	X	X	X	X	X	X	NI	X	X	X	NI	X	X	NI

NOTES:

- X= Mixing processors at different frequencies is not supported. This stepping/frequency is not supported in Dual Processor.
- NI= Currently no known issues associated with mixing these steppings.



DP Platform Population Matrix for the Pentium® III Processor with 133-MHz System Bus in the SECC and SECC2 Package from 800MHz to 1.13GHz

Pentium® III Processor Stepping	800EB MHz cA2	800EB MHz cB0	866 MHz cB0	933 MHz cB0,	1B GHz cB0	800EB MHz cC0	866 MHz cC0,	933 MHz cC0,	1B GHz cC0	1.13 GHz cC0
800EB-MHz cA2	NI	NI	X	X	X	NI	X	X	X	X
800EB MHz cB0	NI	NI	X	X	X	NI	X	X	X	X
866 MHz cB0	X	X	NI	X	X	X	NI	X	X	X
933 MHz cB0	X	X	X	NI	X	X	X	NI	X	X
1B GHz cB0	X	X	X	X	X	X	X	X	X	X
800EB MHz cC0	NI	NI	X	X	X	NI	X	X	X	X
866 MHz cC0	X	X	NI	X	X	X	NI	X	X	X
933 MHz cC0	X	X	X	NI	X	X	X	NI	X	X
1B GHz cC0	X	X	X	X	X	X	X	X	NI	X
1.13 GHz cC0	X	X	X	X	X	X	X	X	X	X

NOTES:

- X= Mixing processors at different frequencies is not supported. This stepping/frequency is not supported in Dual Processor.
- NI= Currently no known issues associated with mixing these steppings.

DP Platform Population Matrix for the Pentium® III Processor with 100-MHz System Bus in the FC-PGA370 Package from 500 MHz to 650 MHz

Pentium® III Processor Stepping	500E MHz cB0	550E MHz cB0	600E MHz cB0	650 MHz cB0	600E MHz cC0	650 MHz cC0	600E MHz cD0
500E-MHz cB0	NI	X	X	X	X	X	X
550E-MHz cB0	X	NI	X	X	X	X	X
600E-MHz cB0	X	X	NI	X	X	X	NI
650-MHz cB0	X	X	X	NI	X	X	X
600E-MHz cC0	X	X	X	X	NI	X	NI
650-MHz cC0	X	X	X	X	X	NI	X
600E-MHz cD0	X	X	X	X	NI	X	NI



PENTIUM® III PROCESSOR SPECIFICATION UPDATE

DP Platform Population Matrix for the Pentium® III Processor with 100-MHz System Bus in the FC-PGA 370 Pin Package from 700 MHz to 1.10 GHz

Pentium® III Processor Stepping	700 MHz cB0	750 MHz cB0	800 MHz cB0	850 MHz cB0	700 MHz cC0	750 MHz cC0	800 MHz cC0	850 MHz cC0	900 MHz cC0	700 MHz cD0	750 MHz cD0	800 MHz cD0	850 MHz cD0	900 MHz cD0	1 GHz cD0	1.10 GHz cD0
700-MHz cB0	NI	X	X	X	NI	X	X	X	X	NI	X	X	X	X	X	X
750-MHz cB0	X	NI	X	X	X	NI	X	X	X	X	NI	X	X	X	X	X
800-MHz cB0	X	X	NI	X	X	X	NI	X	X	X	X	NI	X	X	X	X
850-MHz cB0	X	X	X	NI	X	X	X	NI	X	X	X	X	NI	X	X	X
700-MHz cC0	NI	X	X	X	NI	X	X	X	X	NI	X	X	X	X	X	X
750-MHz cC0	X	NI	X	X	X	NI	X	X	X	X	NI	X	X	X	X	X
800-MHz cC0	X	X	NI	X	X	X	NI	X	X	X	X	NI	X	X	X	X
850-MHz cC0	X	X	X	NI	X	X	X	NI	X	X	X	X	NI	X	X	X
900-MHz cC0	X	X	X	X	X	X	X	X	NI	X	X	X	X	NI	X	X
700-MHz cD0	NI	X	X	X	NI	X	X	X	X	NI	X	X	X	X	X	X
750-MHz cD0	X	NI	X	X	X	NI	X	X	X	X	NI	X	X	X	X	X
800-MHz cD0	X	X	NI	X	X	X	NI	X	X	X	X	NI	X	X	X	X
850-MHz cD0	X	X	X	NI	X	X	X	NI	X	X	X	X	NI	X	X	X
900-MHz cD0	X	X	X	X	X	X	X	X	NI	X	X	X	X	NI	X	X
1 GHz cD0	X	X	X	X	X	X	X	X	X	X	X	X	X	X	NI	X
1.10GHz cD0	X	X	X	X	X	X	X	X	X	X	X	X	X	X	X	NI

NOTES:

- X= Mixing processors at different frequencies is not supported.
- NI= Currently no known issues associated with mixing these steppings.
- TBD= No issues are expected, however further investigation is required to fully validate this DP solution.



PENTIUM® III PROCESSOR SPECIFICATION UPDATE

DP Platform Population Matrix for the Pentium® III Processor with 133-MHz System Bus in the FC-PGA370 Package from 533 MHz to 800 MHz

Pentium® III Processor Stepping	533E B MHz cB0	600E B MHz cB0	667 MHz cB0	733 MHz cB0	800E B MHz cB0	866 MHz cB0	933 MHz cB0	600E B MHz cC0	667 MHz cC0	733 MHz cC0	800 EB MHz cC0	733 MHz cD0	800E B MHz cD0
533EB-MHz cB0	NI	X	X	X	X	X	X	X	X	X	X	X	X
600EB-MHz cB0	X	NI	X	X	X	X	X	NI	X	X	X	X	X
667-MHz cB0	X	X	NI	X	X	X	X	X	NI	X	X	X	X
733-MHz cB0	X	X	X	NI	X	X	X	X	X	NI	X	NI	X
800EB-MHz cB0	X	X	X	X	NI	X	X	X	X	X	NI	X	NI
866-MHz cB0	X	X	X	X	X	NI	X	X	X	X	X	X	X
933-MHz cB0	X	X	X	X	X	X	NI	X	X	X	X	X	X
600EB-MHz cC0	X	NI	X	X	X	X	X	NI	X	X	X	X	X
667-MHz cC0	X	X	NI	X	X	X	X	X	NI	X	X	X	X
733-MHz cC0	X	X	X	NI	X	X	X	X	X	NI	X	X	X
800EB-MHz cC0	X	X	X	X	NI	X	X	X	X	X	NI	X	X
733-MHz cD0	X	X	X	NI	X	X	X	X	X	NI	X	NI	X
800EB-MHz cD0	X	X	X	X	NI	X	X	X	X	X	NI	X	NI

NOTES:

- X= Mixing processors at different frequencies is not supported.
- NI= Currently no known issues associated with mixing these steppings.
- TBD= No issues are expected, however further investigation is required to fully validate this DP solution.

DP Platform Population Matrix for the Pentium® III Processor with 133-MHz System Bus in the FC-PGA370 Package from 866 MHz to 1 GHz

Pentium® III Processor Stepping	866 MHz cB0	933 MHz cB0	866 MHz cC0	933 MHz cC0	1B GHz cC0	866 MHz cD0	933 MHz cD0	1B GHz cD0
866-MHz cB0	NI	X	NI	X	X	NI	X	X
933-MHz cB0	X	NI	X	NI	X	X	NI	X
866-MHz cC0	NI	X	NI	X	X	NI	X	X
933-MHz cC0	X	NI	X	NI	X	X	NI	X
1B-GHz cC0	X	X	X	X	NI	X	X	NI
866-MHz cD0	NI	X	NI	X	X	NI	X	X
933-MHz cD0	X	NI	X	NI	X	X	NI	X
1B-GHz cD0	X	X	X	X	NI	X	X	NI

NOTES:

- X= Mixing processors at different frequencies is not supported.
- NI= Currently no known issues associated with mixing these steppings.



PENTIUM® III PROCESSOR SPECIFICATION UPDATE

TBD= No issues are expected, however further investigation is required to fully validate this DP solution.

DP Platform Population Matrix for the Pentium® III Processor with 133-MHz System Bus in the FC-PGA2 Package from 866 MHz to 1.4 GHz and uFCBGA2 Package for 800 MHz to 933 MHz														
Pentium® III Processor Stepping	866 MHz cD0	933 MHz cD0	1B GHz cD0	1.13 GHz cD0	800 MHz tA1	800 MHz tB1	933 MHz tB1	1 GHz tA1	1.13 GHz tA1	1.13 GHz tB1	1.26 GHz tA1	1.26 GHz tB1	1.4 GHz tA1	1.4 GHz tB1
866-MHz cD0	NI	X	X	X	X	X	X	X	X	X	X	X	X	X
933-MHz cD0	X	NI	X	X	X	X	X	X	X	X	X	X	X	X
1B-GHz cD0	X	X	NI	X	X	X	X	X	X	X	X	X	X	X
1.13-GHz cD0	X	X	X	NI	X	X	X	X	X	X	X	X	X	X
800-MHz tA1 (uFCBGA2)	X	X	X	X	NI	NI	X	X	X	X	X	X	X	X
800-MHz tB1 (uFCBGA2)	X	X	X	X	NI	NI	X	X	X	X	X	X	X	X
933-MHz tB1 (uFCBGA2)	X	X	X	X	X	X	NI	X	X	X	X	X	X	X
1-GHz tA1	X	X	X	X	X	X	X	NI	X	X	X	X	X	X
1.13-GHz tA1	X	X	X	X	X	X	X	X	NI	NI	X	X	X	X
1.26-GHz tA1	X	X	X	X	X	X	X	X	X	X	NI	NI	X	X
1.4-GHz tA1	X	X	X	X	X	X	X	X	X	X	X	X	NI	NI
1.13-GHz tB1	X	X	X	X	X	X	X	X	NI	NI	X	X	X	X
1.26-GHz tB1	X	X	X	X	X	X	X	X	X	X	NI	NI	X	X
1.4-GHz tB1	X	X	X	X	X	X	X	X	X	X	X	X	NI	NI

NOTES:

- X= Mixing processors at different frequencies is not supported.
- NI= Currently no known issues associated with mixing these steppings.
- TBD= No issues are expected, however further investigation is required to fully validate this DP solution.



PENTIUM® III PROCESSOR SPECIFICATION UPDATE

Pentium® III Processor Identification and Package Information

S-Spec	Core Steppings	CPUID	Speed (MHz) Core/Bus ¹¹	L2 Size (Kbytes)	Tag RAM/Steppings	ECC/Non-ECC	Processor Substrate Revision	Package and Revision	Notes
SL364	kB0	0672h	450/100	512	T6P-e/A0	ECC	D	SECC2†	1, 2, 4
SL365	kB0	0672h	500/100	512	T6P-e/A0	ECC	D	SECC2†	1, 2, 4, 8
SL3CC	kB0	0672h	450/100	512	T6P-e/A0	ECC	D	SECC2†	1, 2, 3, 4
SL3CD	kB0	0672h	500/100	512	T6P-e/A0	ECC	D	SECC2†	1, 2, 3, 4
SL38E	kB0	0672h	450/100	512	T6P-e/A0	ECC	D	S.E.C.C	1, 2, 4
SL38F	kB0	0672h	500/100	512	T6P-e/A0	ECC	D	S.E.C.C	1, 2, 4
SL35D	kC0	0673h	450/100	512	T6P-e/A0	ECC	E	SECC2†	1, 4
SL37C	kC0	0673h	450/100	512	T6P-e/A0	ECC	E	SECC2†	1, 3, 4
SL35E	kC0	0673h	500/100	512	T6P-e/A0	ECC	E	SECC2†	1, 4
SL37D	kC0	0673h	500/100	512	T6P-e/A0	ECC	E	SECC2†	1, 3, 4
SL3F7	kC0	0673h	550/100	512	T6P-e/A0	ECC	E	SECC2†	1, 4
SL3FJ	kC0	0673h	550/100	512	T6P-e/A0	ECC	E	SECC2†	1, 3, 4
SL3BN	kC0	0673h	533B/133	512	T6P-e/A0	ECC	E	SECC2†	1, 4, 10
SL3E9	kC0	0673h	533B/133	512	T6P-e/A0	ECC	E	SECC2†	1, 3, 4, 10
SL3JM	kC0	0673h	600/100	512	T6P-e/A0	ECC	E	SECC2†	1, 4
SL3JT	kC0	0673h	600/100	512	T6P-e/A0	ECC	E	SECC2†	1, 3, 4
SL3JP	kC0	0673h	600B/133	512	T6P-e/A0	ECC	E	SECC2†	1, 4, 10
SL3JU	kC0	0673h	600B/133	512	T6P-e/A0	ECC	E	SECC2†	1, 3, 4, 10
SL3Q9	cA2	0681h	500E/100	256	N/A	ECC	B	FC-PGA (370 pin)	9, 10
SL3R2	cA2	0681h	500E/100	256	N/A	ECC	B	FC-PGA (370 pin)	7, 9, 10
SL3VF	cA2	0681h	533EB/133	256	N/A	ECC	B	FC-PGA (370 pin)	9, 10
SL3VA	cA2	0681h	533EB/133	256	N/A	ECC	B	FC-PGA (370 pin)	7, 9, 10
SL3QA	cA2	0681h	550E/100	256	N/A	ECC	B	FC-PGA (370 pin)	9, 10
SL3R3	cA2	0681h	550E/100	256	N/A	ECC	B	FC-PGA (370 pin)	7, 9, 10
SL3VH	cA2	0681h	600E/100	256	N/A	ECC	B	FC-PGA (370 pin)	9, 10
SL3NL	cA2	0681h	600E/100	256	N/A	ECC	B	FC-PGA (370 pin)	7, 9, 10
SL3VG	cA2	0681h	600EB/133	256	N/A	ECC	B	FC-PGA (370 pin)	9, 10



PENTIUM® III PROCESSOR SPECIFICATION UPDATE

Pentium® III Processor Identification and Package Information

S-Spec	Core Steppings	CPUID	Speed (MHz) Core/Bus ¹¹	L2 Size (Kbytes)	Tag RAM/ Steppings	ECC/ Non-ECC	Processor Substrate Revision	Package and Revision	Notes
SL3VB	cA2	0681h	600EB/133	256	N/A	ECC	B	FC-PGA (370 pin)	7, 9, 10
SL3VJ	cA2	0681h	650/100	256	N/A	ECC	B	FC-PGA (370 pin)	9
SL3NM	cA2	0681h	650/100	256	N/A	ECC	B	FC-PGA (370 pin)	7, 9
SL3VK	cA2	0681h	667/133	256	N/A	ECC	B	FC-PGA (370 pin)	9
SL3T2	cA2	0681h	667/133	256	N/A	ECC	B	FC-PGA (370 pin)	7, 9
SL3VL	cA2	0681h	700/100	256	N/A	ECC	B	FC-PGA (370 pin)	9
SL3T3	cA2	0681h	700/100	256	N/A	ECC	B	FC-PGA (370 pin)	7, 9
SL3VM	cA2	0681h	733/133	256	N/A	ECC	B	FC-PGA (370 pin)	9
SL3T4	cA2	0681h	733/133	256	N/A	ECC	B	FC-PGA (370 pin)	7, 9
SL3VN	cA2	0681h	750/100	256	N/A	ECC	B	FC-PGA (370 pin)	9
SL3VC	cA2	0681h	750/100	256	N/A	ECC	B	FC-PGA (370 pin)	7, 9
SL3WB	cA2	0681h	800EB/133	256	N/A	ECC	B	FC-PGA (370 pin)	9, 10
SL3VE	cA2	0681h	800EB/133	256	N/A	ECC	B	FC-PGA (370 pin)	7, 9, 10
SL3X4	cA2	0681h	800/100	256	N/A	ECC	B	FC-PGA (370 pin)	9, 10
SL3VD	cA2	0681h	800/100	256	N/A	ECC	B	FC-PGA (370 pin)	7, 9, 10
SL444	cB0	0683h	500E/100	256	N/A	ECC	B	FC-PGA (370 pin)	10
SL446	cB0	0683h	500E/100	256	N/A	ECC	B	FC-PGA (370 pin)	10
SL45R	cB0	0683h	500E/100	256	N/A	ECC	B	FC-PGA (370 pin)	10, 7
SL3XS	cB0	0683h	533EB/133	256	N/A	ECC	B	FC-PGA (370 pin)	10
SL45S	cB0	0683h	533EB/133	256	N/A	ECC	B	FC-PGA (370 pin)	10, 7
SL44G	cB0	0683h	550E/100	256	N/A	ECC	B	FC-PGA (370 pin)	7



PENTIUM® III PROCESSOR SPECIFICATION UPDATE

Pentium® III Processor Identification and Package Information

S-Spec	Core Steppings	CPUID	Speed (MHz) Core/Bus ¹¹	L2 Size (Kbytes)	Tag RAM/ Steppings	ECC/ Non-ECC	Processor Substrate Revision	Package and Revision	Notes
SL45T	cB0	0683h	550E/100	256	N/A	ECC	B	FC-PGA (370 pin)	10, 7
SL3XT	cB0	0683h	600EB/133	256	N/A	ECC	B	FC-PGA (370 pin)	10
SL45V	cB0	0683h	600EB/133	256	N/A	ECC	B	FC-PGA (370 pin)	10, 7
SL3XU	cB0	0683h	600E/100	256	N/A	ECC	B	FC-PGA (370 pin)	10
SL45U	cB0	0683h	600E/100	256	N/A	ECC	B	FC-PGA (370 pin)	10, 7
SL3XV	cB0	0683h	650/100	256	N/A	ECC	B	FC-PGA (370 pin)	
SL45W	cB0	0683h	650/100	256	N/A	ECC	B	FC-PGA (370 pin)	7
SL3XW	cB0	0683h	667/133	256	N/A	ECC	B	FC-PGA (370 pin)	
SL45X	cB0	0683h	667/133	256	N/A	ECC	B	FC-PGA (370 pin)	7
SL3XX	cB0	0683h	700/100	256	N/A	ECC	B	FC-PGA (370 pin)	
SL45Y	cB0	0683h	700/100	256	N/A	ECC	B	FC-PGA (370 pin)	7
SL45Z	cB0	0683h	733/133	256	N/A	ECC	B	FC-PGA (370 pin)	7
SL3XY	cB0	0683h	733/133	256	N/A	ECC	B	FC-PGA (370 pin)	
SL3XZ	cB0	0683h	750/100	256	N/A	ECC	B	FC-PGA (370 pin)	
SL462	cB0	0683h	750/100	256	N/A	ECC	B	FC-PGA (370 pin)	7
SL3Y2	cB0	0683h	800EB/133	256	N/A	ECC	B	FC-PGA (370 pin)	10
SL464	cB0	0683h	800EB/133	256	N/A	ECC	B	FC-PGA (370 pin)	7, 10
SL3Y3	cB0	0683h	800/100	256	N/A	ECC	B	FC-PGA (370 pin)	10
SL463	cB0	0683h	800/100	256	N/A	ECC	B	FC-PGA (370 pin)	7, 10
SL43H	cB0	0683h	850/100	256	N/A	ECC	B	FC-PGA (370 pin)	



PENTIUM® III PROCESSOR SPECIFICATION UPDATE

Pentium® III Processor Identification and Package Information

S-Spec	Core Steppings	CPUID	Speed (MHz) Core/Bus ¹¹	L2 Size (Kbytes)	Tag RAM/ Steppings	ECC/ Non-ECC	Processor Substrate Revision	Package and Revision	Notes
SL49G	cB0	0683h	850/100	256	N/A	ECC	B	FC-PGA (370 pin)	7
SL43J	cB0	0683h	866/133	256	N/A	ECC	B	FC-PGA (370 pin)	
SL49H	cB0	0683h	866/133	256	N/A	ECC	B	FC-PGA (370 pin)	7
SL44J	cB0	0683h	933/133	256	N/A	ECC	B	FC-PGA (370 pin)	
SL4CM	cC0	0686h	600E/100	256	N/A	ECC	C	FC-PGA (370 pin)	
SL4CL	cC0	0686h	600EB/133	256	N/A	ECC	C	FC-PGA (370 pin)	
SL4CK	cC0	0686h	650/100	256	N/A	ECC	C	FC-PGA (370 pin)	
SL4CJ	cC0	0686h	667/133	256	N/A	ECC	C	FC-PGA (370 pin)	
SL4CH	cC0	0686h	700/100	256	N/A	ECC	C	FC-PGA (370 pin)	
SL4M7	cC0	0686h	700/100	256	N/A	ECC	C	FC-PGA (370 pin)	7, 13
SL4CG	cC0	0686h	733/133	256	N/A	ECC	C	FC-PGA (370 pin)	
SL4M8	cC0	0686h	733/133	256	N/A	ECC	C	FC-PGA (370 pin)	7, 13
SL4CF	cC0	0686h	750/100	256	N/A	ECC	C	FC-PGA (370 pin)	
SL4M9	cC0	0686h	750/100	256	N/A	ECC	C	FC-PGA (370 pin)	7, 13
SL4CE	cC0	0686h	800/100	256	N/A	ECC	C	FC-PGA (370 pin)	
SL4MA	cC0	0686h	800/100	256	N/A	ECC	C	FC-PGA (370 pin)	7, 13
SL4CD	cC0	0686h	800EB/133	256	N/A	ECC	C	FC-PGA (370 pin)	
SL4MB	cC0	0686h	800EB/133	256	N/A	ECC	C	FC-PGA (370 pin)	7, 13
SL4CC	cC0	0686h	850/100	256	N/A	ECC	C	FC-PGA (370 pin)	
SL4MC	cC0	0686h	850/100	256	N/A	ECC	C	FC-PGA (370 pin)	7, 13
SL4CB	cC0	0686h	866/133	256	N/A	ECC	C	FC-PGA (370 pin)	



PENTIUM® III PROCESSOR SPECIFICATION UPDATE

Pentium® III Processor Identification and Package Information

S-Spec	Core Steppings	CPUID	Speed (MHz) Core/Bus ¹¹	L2 Size (Kbytes)	Tag RAM/ Steppings	ECC/ Non-ECC	Processor Substrate Revision	Package and Revision	Notes
SL4MD	cC0	0686h	866/133	256	N/A	ECC	C	FC-PGA (370 pin)	7, 13
SL4SD	cC0	0686h	900/100	256	N/A	ECC	C	FC-PGA (370 pin)	
SL4C9	cC0	0686h	933/133	256	N/A	ECC	C	FC-PGA (370 pin)	
SL4ME	cC0	0686h	933/133	256	N/A	ECC	C	FC-PGA (370 pin)	7, 15
SL4C8	cC0	0686h	1B GHz/133	256	N/A	ECC	C	FC-PGA (370 pin)	
SL4MF	cC0	0686h	1B GHz/133	256	N/A	ECC	C	FC-PGA (370 pin)	15
SL4WM	cC0	0686h	1B GHz/133	256	N/A	ECC	C	FC-PGA (370 pin)	16
SL5BT	cD0	068Ah	600E/100	256	N/A	ECC	C	FC-PGA (370 pin)	N/A
SL4ZM	cD0	068Ah	700/100	256	N/A	ECC	C	FC-PGA (370 pin)	17
SL4ZL	cD0	068Ah	733/133	256	N/A	ECC	C	FC-PGA (370 pin)	17
SL4Z4	cD0	068Ah	750/100	256	N/A	ECC	C	FC-PGA (370 pin)	17
SL4ZN	cD0	068Ah	800/100	256	N/A	ECC	C	FC-PGA (370 pin)	17
SL52P	cD0	068Ah	800EB/133	256	N/A	ECC	C	FC-PGA (370 pin)	17
SL5QD	cD0	068Ah	800EB/133	256	N/A	ECC	C	FC-PGA 2 (370 pin)	17
SL4Z2	cD0	068Ah	850/100	256	N/A	ECC	C	FC-PGA (370 pin)	17
SL49G	cD0	068Ah	850/100	256	N/A	ECC	C	FC-PGA (370 pin)	7, 17
SL5BS	cD0	068Ah	900/100	256	N/A	ECC	C	FC-PGA (370 pin)	17
SL4ZJ	cD0	068Ah	866/133	256	N/A	ECC	C	FC-PGA (370 pin)	17
SL49H	cD0	068Ah	866/133	256	N/A	ECC	C	FC-PGA (370 pin)	7, 17
SL5B5/	cD0	068Ah	866/133	256	N/A	ECC	C	FC-PGA (370 pin)	7, 17



PENTIUM® III PROCESSOR SPECIFICATION UPDATE

Pentium® III Processor Identification and Package Information

S-Spec	Core Steppings	CPUID	Speed (MHz) Core/Bus ¹¹	L2 Size (Kbytes)	Tag RAM/ Steppings	ECC/ Non-ECC	Processor Substrate Revision	Package and Revision	Notes
SL5DX	cD0	068Ah	866/133	256	N/A	ECC	C	FC-PGA (370 pin)	7, 17
SL5QE	cD0	068Ah	866/133	256	N/A	ECC	C	FC-PGA (370 pin)	17, 18
SL52Q	cD0	068Ah	933/133	256	N/A	ECC	C	FC-PGA (370 pin)	17
SL5DW	cD0	068Ah	933/133	256	N/A	ECC	C	FC-PGA (370 pin)	7, 17
SL5U3	cD0	068Ah	933MHz /133	256	N/A	ECC	C	FC-PGA2 (370 pin)	17
SL5QV	cD0	068Ah	1GHz /100	256	N/A	ECC	C	FC-PGA (370 pin)	
SL52R	cD0	068Ah	1BGHz/133	256	N/A	ECC	C	FC-PGA (370 pin)	17
SL4F9	cD0	068Ah	1BGHz/133	256	N/A	ECC	C	FC-PGA (370 pin)	7, 17
SL5DV	cD0	068Ah	1BGHz/133	256	N/A	ECC	C	FC-PGA (370 pin)	7, 17
SL5QW	cD0	068Ah	1.10GHz /100	256	N/A	ECC	C	FC-PGA (370 pin)	
SL5B3	cD0	068Ah	1BGHz/133	256	N/A	ECC	C	FC-PGA 2 (370 pin)	19
SL5FQ	cD0	068Ah	1BGHz/133	256	N/A	ECC	C	FC-PGA 2 (370 pin)	7, 19
SL5B5	cD0	068Ah	866/133	256	N/A	ECC	C	FC-PGA 2 (370 pin)	7, 17
SL5QF	cD0	068Ah	933/133	256	N/A	ECC	C	FC-PGA (370 pin)	17, 18
SL5QJ	cD0	068Ah	1B GHz/133	256	N/A	ECC	C	FC-PGA2 (370 pin)	18, 19
SL4YV	cD0	068Ah	1.13 GHz/133	256	N/A	ECC	C	FC-PGA2 (370 pin)	19
SL5B2	cD0	068Ah	1.13 GHz/133	256	N/A	ECC	C	FC-PGA2 (370 pin)	17
SL4YV	cD0	068Ah	1.13 GHz/133	256	N/A	ECC	C	FC-PGA xvi(370 pin)	17
SL5QK	cD0	068Ah	1.13GHz/133	256	N/A	ECC	C	FC-PGA2 (370 pin)	18, 19,20
SL5GN	tA1	06B1h	1.2GHz /133	256	N/A	ECC		FC-PGA2 (370 pin)	9



PENTIUM® III PROCESSOR SPECIFICATION UPDATE

Pentium® III Processor Identification and Package Information

S-Spec	Core Steppings	CPUID	Speed (MHz) Core/Bus ¹¹	L2 Size (Kbytes)	Tag RAM/ Steppings	ECC/ Non-ECC	Processor Substrate Revision	Package and Revision	Notes
SL5PM	tA1	06B1h	1.2GHz /133	256	N/A	ECC		FC-PGA2 (370 pin)	7, 9
SL5GQ	tA1	06B1h	1.13GHz/133	256	N/A	ECC		FC-PGA2 (370 pin)	9
SL5LT	tA1	06B1h	1.13GHz/133	256	N/A	ECC		FC-PGA2 (370 pin)	7, 9
SL5VX	tA1	06B1h	1.333GHz /133	256	N/A	ECC		FC-PGA2 (370 pin)	9
SL64W	tA1	06B1h	1.40 GHz/133	256	No	ECC		FC-PGA2	9
SL5GR	tA1	06B1h	1GHz /133	256	N/A	ECC		FC-PGA2 (370 pin)	9
SL66D	tA1	06B1h	800 MHz-S /133	512	N/A	ECC		uFC-BGA	20, 21
SL6HC	tB1	06B4h	800 MHz-S /133	512	N/A	ECC		uFC-BGA	20, 21
SL5PU	tA1	06B1h	1.13GHz-S /133	512	N/A	ECC		FC-PGA2 (370 pin)	20
SL5LV	tA1	06B1h	1.13GHz-S /133	512	N/A	ECC		FC-PGA2 (370 pin)	7, 20
SL5QL	tA1	06B1h	1.26 GHz-S /133	512	N/A	ECC		FC-PGA2 (370 pin)	20
SL5LW	tA1	06B1h	1.26 GHz-S /133	512	N/A	ECC		FC-PGA2 (370 pin)	7, 20
SL5LV	tA1	06B1h	1.13GHz-S /133	512	N/A	ECC		FC-PGA2 (370 pin)	7, 20
SL657	tA1	06B1h	1.4 GHz-S /133	512	N/A	ECC		FC-PGA2 (370 pin)	7, 20
SL6BW	tB1	06B4h	1.13GHz-S /133	512	N/A	ECC		FC-PGA2 (370 pin)	20
SL6BX	tB1	06B4h	1.26GHz-S /133	512	N/A	ECC		FC-PGA2 (370 pin)	20
SL6BY	tB1	06B4h	1.4GHz-S /133	512	N/A	ECC		FC-PGA2 (370 pin)	20
SL3H7	cA2	0681h	600EB/133	256	N/A	ECC	B	SECC2	10,20
SL3NB	cA2	0681h	600EB/133	256	N/A	ECC	B	SECC2	8,10,7,20
SL3KV	cA2	0681h	650/100	256	N/A	ECC	B	SECC2	10,7, 20
SL3NR	cA2	0681h	650/100	256	N/A	ECC	B	SECC2	8,10, 20



PENTIUM® III PROCESSOR SPECIFICATION UPDATE

Pentium® III Processor Identification and Package Information

S-Spec	Core Steppings	CPUID	Speed (MHz) Core/Bus ¹¹	L2 Size (Kbytes)	Tag RAM/ Steppings	ECC/ Non-ECC	Processor Substrate Revision	Package and Revision	Notes
SL3KW	cA2	0681h	667/133	256	N/A	ECC	B	SECC2	7, 20
SL3SY	cA2	0681h	700/100	256	N/A	ECC	B	SECC2	8,10
SL3SB	cA2	0681h	700/100	256	N/A	ECC	B	SECC2	8,10
SL3S9	cA2	0681h	700/100	256	N/A	ECC	B	SECC2	8,10
SL3SZ	cA2	0681h	733/133	256	N/A	ECC	B	SECC2	8,10
SL3H6	cA2	0681h	600E/100	256	N/A	ECC	B	SECC2	8,10
SL3SB	cA2	0681h	733/133	256	N/A	ECC	B	SECC2	8,10
SL3ND	cA2	0681h	667/133	256	N/A	ECC	B	SECC2	8,10
SL3N6	cA2	0681h	533EB/133	256	N/A	ECC	B	SECC2	8,10
SL3SX	cA2	0681h	533EB/133	256	N/A	ECC	B	SECC2	8,10
SL3V5	cA2	0681h	550E/100	256	N/A	ECC	B	SECC2	8,10
SL3N7	cA2	0681h	550E/100	256	N/A	ECC	B	SECC2	8,10
SL3NA	cA2	0681h	600E/100	256	N/A	ECC	B	SECC2	8,10
SL3WC	cA2c	0681h	750/100	256	N/A	ECC	B	SECC2	8,10
SL3V6	cA2	0681h	750/100	256	N/A	ECC	B	SECC2	8,10
SL3Z6	cA2	0681h	800/100	256	N/A	ECC	B	SECC2	8,10
SL3V7	cA2	0681h	800/100	256	N/A	ECC	B	SECC2	8,10
SL3WA	cA2	0681h	800EB/133	256	N/A	ECC	B	SECC2	8,10
SL3V8	cA2	0681h	800EB/133	256	N/A	ECC	B	SECC2	8,10
SL4G7	cA2	0681h	800EB/133	256	N/A	ECC	B	SECC2	8,10
SL3XG	cB0	0683h	533EB/133	256	N/A	ECC	B	SECC2	8, 10
SL44W	cB0c	0683h	533EB/133	256	N/A	ECC	B	SECC2	8,10
SL3XH	cB0	0683h	550E/100	256	N/A	ECC	B	SECC2	8,10
SL44X	cB0	0683h	550E/100	256	N/A	ECC	B	SECC2	8,10
SL43E	cB0	0683h	600E/100	256	N/A	ECC	B	SECC2	8,10
SL44Y	cB0	0683h	600E/100	256	N/A	ECC	B	SECC2	8,10



PENTIUM® III PROCESSOR SPECIFICATION UPDATE

Pentium® III Processor Identification and Package Information

S-Spec	Core Steppings	CPUID	Speed (MHz) Core/Bus ¹¹	L2 Size (Kbytes)	Tag RAM/ Steppings	ECC/ Non-ECC	Processor Substrate Revision	Package and Revision	Notes
SL3XJ	cB0	0683h	600EB/133	256	N/A	ECC	B	SECC2	8, 10
SL44Z	cB0	0683h	600EB/133	256	N/A	ECC	B	SECC2	8, 10
SL3XK	cB0	0683h	650/100	256	N/A	ECC	B	SECC2	8, 10
SL452	cB0	0683h	650/100	256	N/A	ECC	B	SECC2	8, 10
SL3XL	cB0	0683h	667/133	256	N/A	ECC	B	SECC2	8, 10
SL453	cB0	0683h	667/133	256	N/A	ECC	B	SECC2	8, 10
SL3XM	cB0	0683h	700/100	256	N/A	ECC	B	SECC2	8, 10
SL454	cB0	0683h	700/100	256	N/A	ECC	B	SECC2	8, 10
SL3XN	cB0	0683h	733/133	256	N/A	ECC	B	SECC2	8, 10
SL455	cB0	0683h	733/133	256	N/A	ECC	B	SECC2	8, 10
SL3XP	cB0	0683h	750/100	256	N/A	ECC	B	SECC2	8, 10
SL456	cB0	0683h	750/100	256	N/A	ECC	B	SECC2	8, 10
SL3XQ	cB0	0683h	800EB/133	256	N/A	ECC	B	SECC2	8, 10
SL458	cB0	0683h	800EB/133	256	N/A	ECC	B	SECC2	8, 10
SL3XR	cB0	0683h	800/100	256	N/A	ECC	B	SECC2	8, 10
SL457	cB0	0683h	800/100	256	N/A	ECC	B	SECC2	8, 10
SL43F	cB0	0683h	850/100	256	N/A	ECC	B	SECC2	8, 10
SL47M	cB0	0683h	850/100	256	N/A	ECC	B	SECC2	8, 10
SL43G	cB0	0683h	866/133	256	N/A	ECC	B	SECC2	8, 10
SL47N	cB0	0683h	866/133	256	N/A	ECC	B	SECC2	8, 10
SL448	cB0	0683h	933/133	256	N/A	ECC	B	SECC2	8, 10
SL47Q	cB0	0683h	933/133	256	N/A	ECC	B	SECC2	8, 10
SL4FP	cB0	0683h	1B GHz/133	256	N/A	ECC	B	SECC2	8, 10
SL48S	cB0	0683h	1B GHz /133	256	N/A	ECC	B	SECC2	8, 10



PENTIUM® III PROCESSOR SPECIFICATION UPDATE

Pentium® III Processor Identification and Package Information

S-Spec	Core Steppings	CPUID	Speed (MHz) Core/Bus ¹¹	L2 Size (Kbytes)	Tag RAM/ Steppings	ECC/ Non-ECC	Processor Substrate Revision	Package and Revision	Notes
SL4C7	cC0	0686h	600E/100	256	N/A	ECC	B	SECC2	8, 10
SL4C6	cC0	0686h	600EB/133	256	N/A	ECC	B	SECC2	8, 10
SL4C5	cC0	0686h	650/100	256	N/A	ECC	B	SECC2	8, 10
SL4C4	cC0	0686h	667/133	256	N/A	ECC	B	SECC2	8, 10
SL4C3	cC0	0686h	700/100	256	N/A	ECC	B	SECC2	8, 10
SL4C2	cC0	0686h	733/133	256	N/A	ECC	B	SECC2	8, 10
SL4KD	cC0	0686h	733/133	256	N/A	ECC	B	SECC2	8, 10
SL4FQ	cC0	0686h	733/133	256	N/A	ECC	B	SECC2	8, 10
SL4BZ	cC0	0686h	750/100	256	N/A	ECC	B	SECC2	8, 10
SL4BY	cC0	0686h	800/100	256	N/A	ECC	B	SECC2	8, 10
SL4KF	cC0	0686h	800/100	256	N/A	ECC	B	SECC2	8, 10
SL4BX	cC0	0686h	800EB/133	256	N/A	ECC	B	SECC2	8, 10
SL4G7	cC0	0686h	800EB/133	256	N/A	ECC	B	SECC2	8, 10
SL4KG	cC0	0686h	800EB/133	256	N/A	ECC	B	SECC2	8, 10
SL4BW	cC0	0686h	850/100	256	N/A	ECC	B	SECC2	8, 10
SL4KH	cC0	0686h	850/100	256	N/A	ECC	B	SECC2	8, 10
SL4BV	cC0	0686h	866/133	256	N/A	ECC	B	SECC2	8, 10
SL4KJ	cC0	0686h	866/133	256	N/A	ECC	B	SECC2	8, 10
SL4BT	cC0	0686h	933/133	256	N/A	ECC	B	SECC2	8, 10
SL4KK	cC0	0686h	933/133	256	N/A	ECC	B	SECC2	8, 10
SL4BR	cC0	0686h	1 GHz/100	256	N/A	ECC	C	SECC2	15
SL4KL	cC0	0686h	1 GHz/100	256	N/A	ECC	C	SECC2	8
SL4BS	cC0	0686h	1B GHz/133	256	N/A	ECC	C	SECC2	10,15
SL4HH	cC0	0686h	1.13 GHz/133	256	N/A	ECC	C	SECC2	12,8
SL69K	tB1	06B4h	933 MHz-S/133	512	N/A	ECC	N/A	uFC-BGA	20,21



Pentium® III Processor Identification and Package Information

S-Spec	Core Steppings	CPUID	Speed (MHz) Core/Bus ¹¹	L2 Size (Kbytes)	Tag RAM/Steppings	ECC/Non-ECC	Processor Substrate Revision	Package and Revision	Notes
SL6QU	tB1	06B4h	1Ghz	512	N/A	ECC	N/A	uFC-BGA	20,21

[†] Unless otherwise noted, all Pentium III processors in S.E.C.C.2 package have an OLGA package core.

Notes:

1. These parts will only operate at the specified core to bus frequency ratio at which they were manufactured and tested. It is not necessary to configure the core frequency ratios by using the A20M#, IGNEE#, LINT[1]/NMI and LINT[0]/INTR pins during RESET.
2. These processors will not shut down automatically upon assertion of THERMTRIP#.
3. This is a boxed processor with an attached heatsink.
4. Performance-monitoring event counters do not reflect MOVD and MOVQ stores to memory on these processors.
5. These parts will not assert THERMTRIP#, nor will they shut down in the event of an over-temperature condition (e.g., Tj = ~135° C).
6. Pin AJ3 is removed from these parts.
7. This is a boxed processor with an unattached fan heatsink.
8. This is a boxed processor with an attached fan heatsink.
9. These processors will not be validated in Dual Processor (DP) applications.
10. The "E" and "B" designators distinguish between Pentium® III processors with the same core frequency but different system bus frequencies and/or cache implementations.
The "E" and "B" designators distinguish between Pentium® III processors with the same core frequency but different system bus frequencies and/or cache implementations.
B = 133 MHz System Bus
E = Processors with "Advanced Transfer Cache" (CPUID 068x and greater only if a frequency overlap exists)
If, for a given core frequency, Pentium III processors are only available with one system bus frequency and one cache implementation, the above designators will not be used (e.g., not all processors with "Advanced Transfer Cache" will have the "E" designation).
11. Speeds will be marked as MHz up to but not including 1GHz. Speeds 1GHz and above will have the GHz marking.
12. Vcc = 1.80V. Tj = 60°C for this 1.13 GHz processor with CPUID 0686.
13. Tj = 80°C, Vcc = 1.70v.
14. Vcc = 1.65V.
15. Vcc = 1.70V for these cCX core steppings. Tj = 70°C for 1.0 GHz. Tj = 75°C for 933 MHz.
16. This SL4WM S-spec part has a VID request of 1.70V, however the processor should be supplied 1.76V at the PGA Vcc pins. See Pentium® III datasheet for further information.
17. Vcc=1.75V for cD0 Core Stepping (CPUID 068Ah). Tj=77 C for 933MHz and Tj=75 C 1GHz. Tj=80 C for 866MHz to 700MHz.
18. This processor is valid for low voltage system bus operation at 1.25V AGTL and normal 1.5V AGTL+ signal levels. This processor is also DP capable at the 1.25V AGTL system bus level. This processor will auto detect differential or single ended clocking.
19. Vcc=1.75V for cD0 Core Stepping (CPUID 068Ah). Tcase=64 C for 1GHz. Tcase = 67 C for 1.13GHz. This package exists as an FC-PGA2 with Integrated Heat Spreader (IHS).
20. These parts are intended for server design applications.
21. Tualatin LV DP 1.15V, non SpeedStep enabled



SUMMARY OF CHANGES

The following table indicates the Errata, Documentation Changes, Specification Clarifications, or Specification Changes that apply to Pentium III processors. Intel intends to fix some of the errata in a future stepping of the component, and to account for the other outstanding issues through documentation or specification changes as noted. This table uses the following notations:

CODES USED IN SUMMARY TABLE

X:	Erratum, Documentation Change, Specification Clarification, or Specification Change applies to the given processor stepping.
(No mark) or (blank box):	This item is fixed in or does not apply to the given stepping.
PlanFix:	This erratum may be fixed in a future of the product.
Fixed:	This erratum has been previously fixed.
NoFix:	There are no plans to fix this erratum.
Doc:	Intel intends to update the appropriate documentation in a future revision.
PKG:	This column refers to errata on the Pentium III processor substrate.
AP:	APIC related erratum.
Shaded:	This item is either new or modified from the previous version of the document.

Each Specification Update item is prefixed with a capital letter to distinguish the product. The key below details the letters that are used in Intel's microprocessor Specification Updates:

- A = Dual-Core Intel® Xeon® processor 7000 sequence
- C = Intel® Celeron® processor
- D = Dual-Core Intel® Xeon™ Processor 2.80 GHz
- E = Intel® Pentium® III processor
- F = Intel® Pentium® processor Extreme Edition and Intel® Pentium® D processor
- I = Dual-Core Intel® Xeon® Processor
- J = 64-bit Intel® Xeon™ processor MP with 1MB L2 Cache
- K = Mobile Intel® Pentium® III processor
- L = Intel® Celeron® D processor
- M = Mobile Intel® Celeron® processor
- N = Intel® Pentium® 4 processor
- O = Intel® Xeon™ processor MP
- P = Intel® Xeon™ processor
- Q = Mobile Intel® Pentium® 4 processor supporting Hyper-Threading Technology on 90-nm process technology
- R = Intel® Pentium® 4 processor on 90 nm process
- S = 64-bit Intel® Xeon™ processor with 800 MHz system bus (1 MB and 2 MB L2 cache versions)
- T = Mobile Intel® Pentium® 4 processor-M
- U = 64-bit Intel® Xeon™ processor MP with up to 8MB L3 Cache
- V = Mobile Intel® Celeron® processor on .13 Micron Process in Micro-FCPGA Package
- W = Intel® Celeron® M processor
- X = Intel® Pentium® M processor on 90nm process with 2-MB L2 Cache
- Y = Intel® Pentium® M processor
- Z = Mobile Intel® Pentium® 4 processor with 533 MHz system bus
- AA = Intel® Pentium® D Processor 900 Sequence and Intel® Pentium® Processor Extreme Edition 955, 965
- AB = Intel® Pentium® 4 Processor 6x1 Sequence
- AC = Intel® Celeron® Processor in 478 Pin Package
- AD = Intel® Celeron® D processor on 65nm process
- AE = Intel® Core™ Duo Processor and Intel® Core™ Solo processor on 65nm process
- AF = Dual-Core Intel® Xeon® processor LV
- AG = Dual-Core Intel® Xeon® Processor 5100 Series
- AH = Intel® Core™2 Duo/Solo Processor for Intel® Centrino® Duo Processor Technology



PENTIUM® III PROCESSOR SPECIFICATION UPDATE

AI = Intel® Core™2 Extreme Processor X6800^Δ and Intel® Core™2 Duo Desktop Processor E6000^Δ and E4000^Δ Sequence
 AJ = Quad-Core Intel® Xeon® Processor 5300 Series
 AK = Intel® Core™2 Extreme quad-core processor QX6700^Δ and Intel® Core™2 Quad processor Q6600^Δ
 AL = Dual-Core Intel® Xeon® Processor 7100 Series
 AM = Intel® Celeron® processor 400 sequence
 AN = Intel® Pentium® Dual-Core Processor
 AO = Quad-Core Intel® Xeon® processor 3200 series
 AP = Dual-Core Intel® Xeon® Processor 3000 Series
 AQ = Intel® Pentium® Dual-Core Desktop Processor E2000^Δ Sequence
 AR = Intel® Celeron processor 500 series
 AS = Intel® Xeon® processor 7200, 7300 series

The Specification Updates for the Pentium processor, Pentium® Pro processor, and other Intel products do not use this convention.

Summary of Errata										
NO.	kB0	kC0	cA2	cB0	cC0	cD0	tA1	tB1	Plans	ERRATA
E1	X	X	X	X	X	X	X	X	NoFix	FP data operand pointer may be incorrectly calculated after FP access which wraps 64-Kbyte boundary in 16-bit code
E2	X	X	X	X	X	X	X	X	NoFix	Differences exist in debug exception reporting
E3	X	X	X	X	X	X	X	X	NoFix	FLUSH# servicing delayed while waiting for STARTUP_IPI in 2-way MP systems
E4	X	X	X	X	X	X	X	X	NoFix	Code fetch matching disabled debug register may cause debug exception
E5	X	X	X	X	X	X	X	X	NoFix	Double ECC error on read may result in BINIT#
E6	X	X	X	X	X	X	X	X	NoFix	FP inexact-result exception flag may not be set
E7	X	X	X	X	X	X	X	X	NoFix	BTM for SMI will contain incorrect FROM EIP
E8	X	X	X	X	X	X	X	X	NoFix	I/O restart in SMM may fail after simultaneous MCE
E9	X	X	X	X	X	X	X	X	NoFix	Branch traps do not function if BTMs are also enabled
E10	X	X							Fixed	Checker BIST failure in FRC mode not signaled
E11	X	X							Fixed	BINIT# assertion causes FRCERR assertion in FRC mode
E12	X	X	X	X	X	X	X	X	NoFix	Machine check exception handler may not always execute successfully

Summary of Errata										
NO.	kB0	kC0	cA2	cB0	cC0	cD0	tA1	tB1	Plans	ERRATA
E13	X	X	X	X	X	X	X	X	NoFix	MCE due to L2 parity error gives L1 MCACOD.LL
E14	X	X	X	X	X	X	X	X	NoFix	LBER may be corrupted after some events
E15	X	X	X	X	X	X	X	X	NoFix	BTMs may be corrupted during simultaneous L1 cache line replacement
E16	X	X	X	X	X	X	X	X	NoFix	EFLAGS discrepancy on a page fault after a multiprocessor TLB shutdown
E17	X	X	X	X	X	X	X	X	NoFix	Near CALL to ESP creates unexpected EIP address
E18	X	X	X	X	X	X	X	X	NoFix	Memory type undefined for nonmemory operations
E19	X	X							Fixed	Infinite snoop stall during L2 initialization of MP systems
E20	X	X	X	X	X	X	X	X	NoFix	FP data operand pointer may not be zero after power on or Reset
E21	X	X	X	X	X	X	X	X	NoFix	MOVD following zeroing instruction can cause incorrect result
E22	X	X	X	X	X	X	X	X	NoFix	Premature execution of a load operation prior to exception handler invocation
E23	X	X	X	X	X	X	X	X	NoFix	Read portion of RMW instruction may execute twice
E24	X	X	X	X	X	X	X	X	NoFix	MC2_STATUS MSR has model-specific error code and machine check architecture error code reversed
E25	X	X	X	X	X	X	X	X	NoFix	Mixed cacheability of lock variables is problematic in MP systems
E26	X	X	X	X	X	X	X	X	NoFix	MOV with debug register causes debug exception
E27	X	X	X	X	X	X	X	X	NoFix	Upper four PAT entries not usable with Mode B or Mode C paging
E28	X	X	X	X	X	X	X	X	NoFix	Data breakpoint exception in a displacement relative near call may corrupt EIP
E29	X	X	X	X	X	X	X	X	NoFix	RDMSR and WRMSR to invalid MSR may not cause GP fault
E30	X	X	X	X	X	X	X	X	NoFix	SYSENTER/SYSEXIT instructions can implicitly load null segment selector to SS and CS registers
E31	X	X	X	X	X	X	X	X	NoFix	PRELOAD followed by EXTEST does not load boundary scan data
E32	X	X							Fixed	Far jump to new TSS with D-bit cleared may cause system hang



PENTIUM® III PROCESSOR SPECIFICATION UPDATE

Summary of Errata										
NO.	kB0	kC0	cA2	cB0	cC0	cD0	tA1	tB1	Plans	ERRATA
E33	X	X	X	X	X	X	X	X	NoFix	INT 1 instruction handler execution could generate a debug exception
E34	X								Fixed	COMISS/UCOMISS may not update EFLAGS under certain conditions
E35	X								Fixed	Transmission error on cache read
E36	X	X	X	X	X	X	X	X	NoFix	Potential loss of data coherency during MP data ownership transfer
E37	X	X	X	X	X	X	X	X	NoFix	Misaligned Locked access to APIC space results in hang
E38	X	X							Fixed	Floating-point exception signal may be deferred
E39	X	X	X	X	X	X	X	X	NoFix	Memory ordering based synchronization may cause a livelock condition in mp systems
E40	X								Fixed	System bus address parity generator may report false AERR#
E41	X	X	X	X	X	X	X	X	NoFix	System bus ECC not functional with 2:1 ratio
E42	X	X	X	X	X	X	X	X	NoFix	Processor may assert DRDY# on a write with no data
E43	X	X	X	X	X	X	X	X	NoFix	GP# fault on WRMSR to ROB_CR_BKUPTMPDR6
E44	X	X	X	X					Fixed	Machine check exception may occur due to improper line eviction in the IFU
E45	X	X	X						Fixed	Performance counters include Streaming SIMD Extensions L1 prefetch
E46	X	X	X	X	X				Fixed	Snoop request may cause DBSY# hang
E47	X	X	X	X	X	X	X	X	NoFix	Lower bits of SMRAM SMBASE register cannot be written with an ITP
E48	X	X	X						Fixed	Task Switch May Cause Wrong PTE and PDE Access Bit to be Set
E49	X	X	X	X	X	X	X	X	NoFix	Unsynchronized Cross-Modifying code operations can cause unexpected instruction execution results
E50			X						Fixed	Processor will erroneously report a BIST failure
E51			X						Fixed	Noise sensitivity issue on processor SMI# pin
E52			X						Fixed	Limitation on cache line ECC detection and correction

Summary of Errata										
NO.	kB0	kC0	cA2	cB0	cC0	cD0	tA1	tB1	Plans	ERRATA
E53			X						Fixed	L2_LD and L2_M_LINES_OUTM performance-monitoring counters do not work
E54				X					Fixed	IFU/DCU deadlock may cause system hang
E55			X						Fixed	L2_DBUS_BUSY performance monitoring counter will not count writes
E56	X	X							Fixed	Incorrect sign may occur on X87 result due to indefinite QNaN result from streaming SIMD extensions multiply
E57	X	X	X	X					Fixed	Deadlock may occur due to illegal-instruction/page-miss combination
E58	X	X	X	X					Fixed	MASKMOVQ instruction interaction with string operation may cause deadlock
E59	X	X	X	X	X	X	X	X	NoFix	MOVD, CVTSS, or PINSRW Following Zeroing Instruction Can Cause Incorrect Result
E60	X	X	X	X	X	X	X	X	NoFix	FLUSH# assertion following STPCLK# may prevent CPU clocks from stopping
E61			X						Fixed	Intermittent failure to assert ADS# during processor power-on
E62	X	X	X	X	X	X			Fixed	Floating-point exception condition may be deferred
E63	X								Fixed	THERMTRIP# may not be asserted as specified
E64			X	X					Fixed	Cache line reads may result in eviction of invalid data.
E65	X	X	X	X	X	X	X	X	NoFix	Snoop probe during FLUSH# could cause L2 to be left in shared state
E66	X	X	X	X					Fixed	Livelock may occur due to IFU line eviction
E67	X	X	X	X					Fixed	Selector for the LTR/LLDT register may get corrupted
E68	X	X	X	X	X	X	X	X	NoFix	INIT does not clear global entries in the TLB
E69	X	X	X	X	X	X	X	X	NoFix	VM bit will be cleared on a double fault handler
E70	X	X	X	X	X	X	X	X	NoFix	Memory aliasing with inconsistent A and D bits may cause processor deadlock
E71	X	X	X	X	X	X	X	X	NoFix	Use of memory aliasing with inconsistent memory type may cause system hang
E72	X	X	X	X	X	X	X	X	NoFix	Processor may report invalid TSS fault instead of Double fault during mode C paging



PENTIUM® III PROCESSOR SPECIFICATION UPDATE

Summary of Errata										
NO.	kB0	kC0	cA2	cB0	cC0	cD0	tA1	tB1	Plans	ERRATA
E73	X	X	X	X	X	X	X	X	NoFix	Machine check exception may occur when interleaving code between different memory types
E74	X	X	X	X	X	X	X	X	NoFix	Wrong ESP register values during a fault in VM86 mode
E75	X	X	X	X	X	X	X	X	NoFix	APIC ICR write may cause interrupt not to be sent when ICR delivery bit pending
E76				X					Fixed	High temperature and low supply voltage operation may result in incorrect processor operation
E77	X	X	X	X	X	X	X	X	PlanFix	During Boundary Scan, BCLK not Sampled High When SLP# is Asserted Low
E78	X	X	X	X	X	X	X		NoFix	Incorrect assertion of THERMTRIP# Signal
E79						X			NoFix	Processor might not exit Sleep State properly upon de-assertion of CPUSLP# signal
E80	X	X	X	X	X	X	X ¹		Fixed	The Instruction Fetch Unit (IFU) may fetch instructions based upon stale CR3 data after a write to CR3 register
E81	X	X	X	X	X	X	X	X	NoFix	Under Some Complex Conditions, the Instructions in the Shadow of a JMP FAR may be Unintentionally Executed and Retired
E82	X	X	X	X	X	X	X	X	NoFix	Processor Does not Flag #GP on Non-zero Write to Certain MSRs
E83	X	X	X	X	X	X	X	X	NoFix	IFU/BSU Deadlock May Cause System Hang
E84	X	X	X	X	X	X	X	X	NoFix	REP MOVS Operation in Fast string Mode Continues in that Mode When Crossing into a Page with a Different Memory Type
E85	X	X	X	X	X	X	X	X	NoFix	The FXSAVE, STOS, MOVS Instructions May Cause a Store Ordering Violation When Data Crosses a Page with a UC Memory Type
E86	X	X	X	X	X	X	X	X	NoFix	POPF and POPFD Instructions that Set the Trap Flag Bit May Cause Unpredictable Processor Behavior
E87	X	X	X	X	X	X	X	X	NoFix	Code Segment Limit Violation May Occur on 4 Gbyte Limit Check

Summary of Errata										
NO.	kB0	kC0	cA2	cB0	cC0	cD0	tA1	tB1	Plans	ERRATA
E88	X	X	X	X	X	X	X	X	NoFix	FST Instruction with Numeric and Null Segment Exceptions May Cause General Protection Faults to be Missed and FP Linear Address (FLA) Mismatch
E89	X	X	X	X	X	X	X	X	NoFix	Code Segment is Wrong on SMM Handler when SMBASE is not Aligned
E90	X	X	X	X	X	X	X	X	NoFix	Page with PAT (Page Attribute Table) Set to USWC (Uncacheable Speculative Write Combine) While Associated MTRR (Memory Type Range Register) is UC (Uncacheable) May Consolidate to UC
E91	X	X	X	X	X	X	X	X	NoFix	Under Certain Conditions LTR (Load Task Register) Instruction May Result in System Hang
E92	X	X	X	X	X	X	X	X	NoFix	Loading from Memory Type USWC (Uncacheable Speculative Write Combine) May Get Its Data Internally Forwarded From a Previous Pending Store
E93	X	X	X	X	X	X	X	X	NoFix	FXSAVE after FNINIT Without an Intervening FP (Floating Point) Instruction May Save Uninitialized Values for FDP (x87 FPU Instruction Operand (Data) Pointer Offset) and FDS (x87 FPU Instruction Operand (Data) Pointer Selector)
E94	X	X	X	X	X	X	X	X	NoFix	FSTP (Floating Point Store) Instruction Under Certain Conditions May Result In Erroneously Setting a Valid Bit on an FP (Floating Point) Stack Register
E95	X	X	X	X	X	X	X	X	NoFix	Invalid Entries in Page-Directory-Pointer-Table-Register (PDPTR) May Cause General Protection (#GP) Exception if the Reserved Bits are Set to One
E96	X	X	X	X	X	X	X	X	NoFix	Writing the Local Vector Table (LVT) when an Interrupt is Pending May Cause an Unexpected Interrupt
E97	X	X	X	X	X	X	X	X	NoFix	The Processor May Report a #TS Instead of a #GP Fault
E98	X	X	X	X	X	X	X	X	NoFix	A Write to an APIC Register Sometimes May Appear to Have Not Occurred
E99	X	X	X	X	X	X	X	X	NoFix	Using 2M/4M Pages When A20M# Is Asserted May Result in Incorrect Address Translations
E100	X	X	X	X	X	X	X	X	NoFix	Values for LBR/BTS/BTM will be Incorrect after an Exit from SMM



PENTIUM® III PROCESSOR SPECIFICATION UPDATE

Summary of Errata										
NO.	kB0	kC0	cA2	cB0	cC0	cD0	tA1	tB1	Plans	ERRATA
E101	X	X	X	X	X	X	X	X	NoFix	INIT Does Not Clear Global Entries in the TLB
E102	X	X	X	X	X	X	X	X	NoFix	REP MOVs/STOS Executing with Fast Strings Enabled and Crossing Page Boundaries with Inconsistent Memory Types may use an Incorrect Data Size or Lead to Memory-Ordering Violations
E103	X	X	X	X	X	X	X	X	NoFix	The BS Flag in DR6 May be Set for Non-Single-Step #DB Exception
E104	X	X	X	X	X	X	X	X	NoFix	Fault on ENTER Instruction May Result in Unexpected Values on Stack Frame
E105	X	X	X	X	X	X	X	X	NoFix	Unaligned Accesses to Paging Structures May Cause the Processor to Hang
E106	X	X	X	X	X	X	X	X	NoFix	INVLPG Operation for Large (2M/4M) Pages May be Incomplete under Certain Conditions
E107	X	X	X	X	X	X	X	X	NoFix	Page Access Bit May be Set Prior to Signaling a Code Segment Limit Fault
E108	X	X	X	X	X	X	X	X	NoFix	EFLAGS, CR0, CR4 and the EXF4 Signal May be Incorrect after Shutdown
E109	X	X	X	X	X	X	X	X	NoFix	Performance Monitoring Event FP_MMX_TRANS_TO_MMX May Not Count Some Transitions

* Fix will be only on Pentium® III processors with CPUID=068xh and not CPUID=067xh

Notes:

- 1- For these steppings, this erratum may be worked around in BIOS.



Summary of Documentation Changes										
NO.	KB0	KC0	cA2	cB0	cC0	cD0	tA1	PKG	Plans	DOCUMENTATION CHANGES
										There are no Documentation Chnages in this revision of the Specification Update

Summary of Specification Clarifications										
NO.	KB0	KC0	cA2	cB0	cC0	cD0	tA1	PKG	Plans	SPECIFICATION CLARIFICATIONS
E1	X	X	X	X	X	X	X		DOC	Specification clarification with respect to time stamp counter

Summary of Specification Clarifications										
NO.	KB0	KC0	cA2	cB0	cC0	cD0	tA1	PKG	Plans	SPECIFICATION CHANGES
										There are no Specification Changes in this revision of the Specification Update

ERRATA

E1. FP Data Operand Pointer May Be Incorrectly Calculated After FP Access Which Wraps 64-Kbyte Boundary in 16-Bit Code

Problem: The FP Data Operand Pointer is the effective address of the operand associated with the last non-control floating-point instruction executed by the machine. If an 80-bit floating-point access (load or store) occurs in a 16-bit mode other than protected mode (in which case the access will produce a segment limit violation), the memory access wraps a 64-Kbyte boundary, and the floating-point environment is subsequently saved, the value contained in the FP Data Operand Pointer may be incorrect.

Implication: A 32-bit operating system running 16-bit floating-point code may encounter this erratum, under the following conditions:

- The operating system is using a segment greater than 64 Kbytes in size.
- An application is running in a 16-bit mode other than protected mode.
- An 80-bit floating-point load or store which wraps the 64-Kbyte boundary is executed.
- The operating system performs a floating-point environment store (FSAVE/FNSAVE/FSTENV/FNSTENV) after the above memory access.
- The operating system uses the value contained in the FP Data Operand Pointer.

Wrapping an 80-bit floating-point load around a segment boundary in this way is not a normal programming practice. Intel has not currently identified any software which exhibits this behavior.

Workaround: If the FP Data Operand Pointer is used in an OS which may run 16-bit floating-point code, care must be taken to ensure that no 80-bit floating-point accesses are wrapped around a 64-Kbyte boundary.

Status: For the steppings affected see the *Summary of Changes* at the beginning of this section.

E2. Differences Exist in Debug Exception Reporting

Problem: There exist some differences in the reporting of code and data breakpoint matches between that specified by previous Intel processor specifications and the behavior of the processor, as described below:

Case 1: The first case is for a breakpoint set on a MOVSS or POPSS instruction, when the instruction following it causes a debug register protection fault (DR7.gd is already set, enabling the fault). The processor reports delayed data breakpoint matches from the MOVSS or POPSS instructions by setting the matching DR6.bi bits, along with the debug register protection fault (DR6.bd). If additional breakpoint faults are matched during the call of the debug fault handler, the processor sets the breakpoint match bits (DR6.bi) to reflect the breakpoints matched by both the MOVSS or POPSS breakpoint and the debug fault handler call. The processor only sets DR6.bd in either situation, and does not set any of the DR6.bi bits.

Case 2: In the second breakpoint reporting failure case, if a MOVSS or POPSS instruction with a data breakpoint is followed by a store to memory which:

a) crosses a 4-Kbyte page boundary,

OR

b) causes the page table Access or Dirty (A/D) bits to be modified,

the breakpoint information for the MOVSS or POPSS will be lost. Previous processors retain this information under these boundary conditions.

Case 3: If they occur after a MOVSS or POPSS instruction, the INTn, INTO, and INT3 instructions zero the DR6.bi bits (bits B0 through B3), clearing pending breakpoint information, unlike previous processors.

Case 4: If a data breakpoint and an SMI (System Management Interrupt) occur simultaneously, the SMI will be serviced via a call to the SMM handler, and the pending breakpoint will be lost.

Case 5: When an instruction that accesses a debug register is executed, and a breakpoint is encountered on the instruction, the breakpoint is reported twice.

Case 6: Unlike previous versions of Intel Architecture processors, P6 family processors will not set the Bi bits for a matching disabled breakpoint unless at least one other breakpoint is enabled.

Implication: When debugging or when developing debuggers for a P6 family processor-based system, this behavior should be noted. Normal usage of the MOVSS or POPSS instructions (i.e., following them with a MOV ESP) will not exhibit the behavior of cases 1-3. Debugging in conjunction with SMM will be limited by case 4.

Workaround: Following MOVSS and POPSS instructions with a MOV ESP instruction when using breakpoints will avoid the first three cases of this erratum. No workaround has been identified for cases 4, 5, or 6.

Status: For the steppings affected see the *Summary of Changes* at the beginning of this section.

E3. FLUSH# Servicing Delayed While Waiting for STARTUP_IPI in 2-way MP Systems

Problem: In a 2-way MP system, if an application processor is waiting for a startup inter-processor interrupt (STARTUP_IPI), then it will not service a FLUSH# pin assertion until it has received the STARTUP_IPI.

Implication: After the 2-way MP initialization protocol, only one processor becomes the bootstrap processor (BSP). The other processor becomes a slave application processor (AP). After losing the BSP arbitration, the AP goes into a wait loop, waiting for a STARTUP_IPI.

The BSP can wake up the AP to perform some tasks with a STARTUP_IPI, and then put it back to sleep with an initialization inter-processor interrupt (INIT_IPI, which has the same effect as asserting INIT#), which returns it to a wait loop. The result is a possible loss of cache coherency if the off-line processor is intended to service a FLUSH# assertion at this point. The FLUSH# will be serviced as soon as the processor is awakened by a STARTUP_IPI, before any other instructions are executed. Intel has not encountered any operating systems that are affected by this erratum.

Workaround: Operating system developers should take care to execute a WBINVD instruction before the AP is taken off-line using an INIT_IPI.

Status: For the steppings affected see the *Summary of Changes* at the beginning of this section.

E4. Code Fetch Matching Disabled Debug Register May Cause Debug Exception

Problem: The bits L0-3 and G0-3 enable breakpoints local to a task and global to all tasks, respectively. If one of these bits is set, a breakpoint is enabled, corresponding to the addresses in the debug registers DR0-DR3. If at least one of these breakpoints is enabled, any of these registers are *disabled* (i.e., L_n and G_n are 0), and RW_n for the disabled register is 00 (indicating a breakpoint on instruction execution), normally an instruction fetch will not cause an instruction-breakpoint fault based on a match with the address in the disabled register(s). However, if the address in a disabled register matches the address of a code fetch which also results in a page fault, an instruction-breakpoint fault will occur.

Implication: While debugging software, extraneous instruction-breakpoint faults may be encountered if breakpoint registers are not cleared when they are disabled. Debug software which does not implement a code breakpoint handler will fail, if this occurs. If a handler is present, the fault will be serviced. Mixing data and code may exacerbate this problem by allowing disabled data breakpoint registers to break on an instruction fetch.

Workaround: The debug handler should clear breakpoint registers before they become disabled.

Status: For the steppings affected see the *Summary of Changes* at the beginning of this section.

E5. Double ECC Error on Read May Result in BINIT#

Problem: For this erratum to occur, the following conditions must be met:

- Machine Check Exceptions (MCEs) must be enabled.
- A dataless transaction (such as a write invalidate) must be occurring simultaneously with a transaction which returns data (a normal read).
- The read data must contain a double-bit uncorrectable ECC error.



If these conditions are met, the Pentium III processor will not be able to determine which transaction was erroneous, and instead of generating an MCE, it will generate a BINIT#.

Implication: The bus will be reinitialized in this case. However, since a double-bit uncorrectable ECC error occurred on the read, the MCE handler (which is normally reached on a double-bit uncorrectable ECC error for a read) would most likely cause the same BINIT# event.

Workaround: Though the ability to drive BINIT# can be disabled in the Pentium III processor, which would prevent the effects of this erratum, overall system behavior would not improve, since the error which would normally cause a BINIT# would instead cause the machine to shut down. No other workaround has been identified.

Status: For the steppings affected see the *Summary of Changes* at the beginning of this section.

E6. FP Inexact-Result Exception Flag May Not Be Set

Problem: When the result of a floating-point operation is not exactly representable in the destination format (1/3 in binary form, for example), an inexact-result (precision) exception occurs. When this occurs, the PE bit (bit 5 of the FPU status word) is normally set by the processor. Under certain rare conditions, this bit may not be set when this rounding occurs. However, other actions taken by the processor (invoking the software exception handler if the exception is unmasked) are not affected. This erratum can only occur if the floating-point operation which causes the precision exception is immediately followed by one of the following instructions:

- FST m32real
- FST m64real
- FSTP m32real
- FSTP m64real
- FSTP m80real
- FIST m16int
- FIST m32int
- FISTP m16int
- FISTP m32int
- FISTP m64int

Note that even if this combination of instructions is encountered, there is also a dependency on the internal pipelining and execution state of both instructions in the processor.

Implication: Inexact-result exceptions are commonly masked or ignored by applications, as it happens frequently, and produces a rounded result acceptable to most applications. The PE bit of the FPU status word may not always be set upon receiving an inexact-result exception. Thus, if these exceptions are unmasked, a floating-point error exception handler may not recognize that a precision exception occurred. Note that this is a “sticky” bit, i.e., once set by an inexact-result condition, it remains set until cleared by software.

Workaround: This condition can be avoided by inserting two NOP instructions between the two floating-point instructions.

Status: For the steppings affected see the *Summary of Changes* at the beginning of this section.

E7. BTM for SMI Will Contain Incorrect FROM EIP

Problem: A system management interrupt (SMI) will produce a Branch Trace Message (BTM), if BTMs are enabled. However, the FROM EIP field of the BTM (used to determine the address of the instruction which was being executed when the SMI was serviced) will not have been updated for the SMI, so the field will report the same FROM EIP as the previous BTM.

Implication: A BTM which is issued for an SMI will not contain the correct FROM EIP, limiting the usefulness of BTMs for debugging software in conjunction with System Management Mode (SMM).

Workaround: None identified.

Status: For the steppings affected see the *Summary of Changes* at the beginning of this section.

E8. I/O Restart in SMM May Fail After Simultaneous MCE

Problem: If an I/O instruction (IN, INS, REP INS, OUT, OUTS, or REP OUTS) is being executed, and if the data for this instruction becomes corrupted, the Pentium III processor will signal a machine check exception (MCE). If the instruction is directed at a device which is powered down, the processor may also receive an assertion of SMI#. Since MCEs have higher priority, the processor will call the MCE handler, and the SMI# assertion will remain pending. However, upon attempting to execute the first instruction of the MCE handler, the SMI# will be recognized and the processor will attempt to execute the SMM handler. If the SMM handler is completed successfully, it will attempt to restart the I/O instruction, but will not have the correct machine state, due to the call to the MCE handler.

Implication: A simultaneous MCE and SMI# assertion may occur for one of the I/O instructions above. The SMM handler may attempt to restart such an I/O instruction, but will have corrupted state due to the MCE handler call, leading to failure of the restart and shutdown of the processor.

Workaround: If a system implementation must support both SMM and MCEs, the first thing the SMM handler code (when an I/O restart is to be performed) should do is check for a pending MCE. If there is an MCE pending, the SMM handler should immediately exit via an RSM instruction and allow the machine check exception handler to execute. If there is not, the SMM handler may proceed with its normal operation.

Status: For the steppings affected see the *Summary of Changes* at the beginning of this section.

E9. Branch Traps Do Not Function If BTMs Are Also Enabled

Problem: If branch traps or branch trace messages (BTMs) are enabled alone, both function as expected. However, if both are enabled, only the BTMs will function, and the branch traps will be ignored.

Implication: The branch traps and branch trace message debugging features cannot be used together.

Workaround: If branch trap functionality is desired, BTMs must be disabled.

Status: For the steppings affected see the *Summary of Changes* at the beginning of this section.



E10. Checker BIST Failure in FRC Mode Not Signaled

Problem: If a system is running in functional redundancy checking (FRC) mode, and the checker of the master-checker pair encounters a hard failure while running the built-in self test (BIST), the checker will tri-state all outputs without signaling an IERR#.

Implication: Assuming the master passes BIST successfully, it will continue execution unchecked, operating without functional redundancy. However, the necessary pull-up on the FRCERR pin will cause an FRCERR to be signaled. The operation of the master depends on the implementation of FRCERR.

Workaround: For successful detection of BIST failure in the checker of an FRC pair, use the FRCERR signal, instead of IERR#.

Status: For the steppings affected see the *Summary of Changes* at the beginning of this section.

E11. BINIT# Assertion Causes FRCERR Assertion in FRC Mode

Problem: If a pair of Pentium III processors are running in functional redundancy checking (FRC) mode, and a catastrophic error condition causes BINIT# to be asserted, the checker in the master-checker pair will enter shutdown. The next bus transaction from the master will then result in the assertion of FRCERR.

Implication: Bus initialization via an assertion of BINIT# occurs as the result of a catastrophic error condition which precludes the continuing reliable execution of the system. Under normal circumstances, the master-checker pair would remain synchronized in the execution of the BINIT# handler. However, due to this erratum, an FRCERR will be signaled. System behavior then depends on the system specific error recovery mechanisms.

Workaround: None identified.

Status: For the steppings affected see the *Summary of Changes* at the beginning of this section.

E12. Machine Check Exception Handler May Not Always Execute Successfully

Problem: An asynchronous machine check exception (MCE), such as a BINIT# event, which occurs during an access that splits a 4-Kbyte page boundary, may leave some internal registers in an indeterminate state. Thus, the MCE handler code may not always run successfully if an asynchronous MCE has occurred previously.

Implication: An MCE may not always result in the successful execution of the MCE handler. However, asynchronous MCEs usually occur upon detection of a catastrophic system condition that would also hang the processor. Leaving MCEs disabled will result in the condition which caused the asynchronous MCE instead causing the processor to enter shutdown. Therefore, leaving MCEs disabled may not improve overall system behavior.

Workaround: No workaround which would guarantee successful MCE handler execution under this condition has been identified.

Status: For the steppings affected see the *Summary of Changes* at the beginning of this section.

E13. MCE Due to L2 Parity Error Gives L1 MCACOD.LL

Problem: If a Cache Reply Parity (CRP) error, Cache Address Parity (CAP) error, or Cache Synchronous Error (CSER) occurs on an access to the Pentium III processor's L2 cache, the resulting Machine Check Architectural Error Code (MCACOD) will be logged with '01' in the LL field. This value indicates an L1 cache error; the value should be '10', indicating an L2 cache error. Note that L2 ECC errors have the correct value of '10' logged.

Implication: An L2 cache access error, other than an ECC error, will be improperly logged as an L1 cache error in MCACOD.LL.

Workaround: None identified.

Status: For the steppings affected see the *Summary of Changes* at the beginning of this section.

E14. LBER May Be Corrupted After Some Events

Problem: The last branch record (LBR) and the last branch before exception record (LBER) can be used to determine the source and destination information for previous branches or exceptions. The LBR contains the source and destination addresses for the last branch or exception, and the LBER contains similar information for the last branch taken before the last exception. This information is typically used to determine the location of a branch which leads to execution of code which causes an exception. However, after a catastrophic bus condition which results in an assertion of BINIT# and the re-initialization of the buses, the value in the LBER may be corrupted. Also, after either a CALL which results in a fault or a software interrupt, the LBER and LBR will be updated to the same value, when the LBER should not have been updated.

Implication: The LBER and LBR registers are used only for debugging purposes. When this erratum occurs, the LBER will not contain reliable address information. The value of LBER should be used with caution when debugging branching code; if the values in the LBR and LBER are the same, then the LBER value is incorrect. Also, the value in the LBER should not be relied upon after a BINIT# event.

Workaround: None identified.

Status: For the steppings affected see the *Summary of Changes* at the beginning of this section.

E15. BTMs May Be Corrupted During Simultaneous L1 Cache Line Replacement

Problem: When Branch Trace Messages (BTMs) are enabled and such a message is generated, the BTM may be corrupted when issued to the bus by the L1 cache if a new line of data is brought into the L1 data cache simultaneously. Though the new line being stored in the L1 cache is stored correctly, and no corruption occurs in the data, the information in the BTM may be incorrect due to the internal collision of the data line and the BTM.

Implication: Although BTMs may not be entirely reliable due to this erratum, the conditions necessary for this boundary condition to occur have only been exhibited during focused simulation testing. Intel has currently not observed this erratum in a system level validation environment.

Workaround: None identified.

Status: For the steppings affected see the *Summary of Changes* at the beginning of this section.



E16. EFLAGS Discrepancy on a Page Fault After a Multiprocessor TLB Shutdown

Problem: This erratum may occur when the Pentium III processor executes one of the following read-modify-write arithmetic instructions and a page fault occurs during the store of the memory operand: ADD, AND, BTC, BTR, BTS, CMPXCHG, DEC, INC, NEG, NOT, OR, ROL/ROR, SAL/SAR/SHL/SHR, SHLD, SHRD, SUB, XOR, and XADD. In this case, the EFLAGS value pushed onto the stack of the page fault handler may reflect the status of the register after the instruction would have completed execution rather than before it. The following conditions are required for the store to generate a page fault and call the operating system page fault handler:

1. The store address entry must be evicted from the DTLB by speculative loads from other instructions that hit the same way of the DTLB before the store has completed. DTLB eviction requires at least three-load operations that have linear address bits 15:12 equal to each other and address bits 31:16 different from each other in close physical proximity to the arithmetic operation.
2. The page table entry for the store address must have its permissions tightened during the very small window of time between the DTLB eviction and execution of the store. Examples of page permission tightening include from Present to Not Present or from Read/Write to Read Only, etc.
3. Another processor, without corresponding synchronization and TLB flush, must cause the permission change.

Implication: This scenario may only occur on a multiprocessor platform running an operating system that performs “lazy” TLB shutdowns. The memory image of the EFLAGS register on the page fault handler’s stack prematurely contains the final arithmetic flag values although the instruction has not yet completed. Intel has not identified any operating systems that inspect the arithmetic portion of the EFLAGS register during a page fault nor observed this erratum in laboratory testing of software applications.

Workaround: No workaround is needed upon normal restart of the instruction, since this erratum is transparent to the faulting code and results in correct instruction behavior. Operating systems may ensure that no processor is currently accessing a page that is scheduled to have its page permissions tightened or have a page fault handler that ignores any incorrect state.

Status: For the steppings affected see the *Summary of Changes* at the beginning of this section.

E17. Near CALL to ESP Creates Unexpected EIP Address

Problem: As documented, the CALL instruction saves procedure linking information in the procedure stack and jumps to the called procedure specified with the destination (target) operand. The target operand specifies the address of the first instruction in the called procedure. This operand can be an immediate value, a general-purpose register, or a memory location. When accessing an absolute address indirectly using the stack pointer (ESP) as a base register, the base value used is the value in the ESP register before the instruction executes. However, when accessing an absolute address directly using ESP as the base register, the base value used is the value of ESP *after* the return value is pushed on the stack, not the value in the ESP register *before* the instruction executed.

Implication: Due to this erratum, the processor may transfer control to an unintended address. Results are unpredictable, depending on the particular application, and can range from no effect to the unexpected termination of the application due to an exception. Intel has observed this erratum only in a focused testing environment. Intel has not observed any commercially available operating system, application, or compiler that makes use of or generates this instruction.

Workaround: If the other seven general-purpose registers are unavailable for use, and it is necessary to do a CALL via the ESP register, first push ESP onto the stack, then perform an *indirect* call using ESP (e.g., CALL [ESP]). The saved version of ESP should be popped off the stack after the call returns.

Status: For the steppings affected see the *Summary of Changes* at the beginning of this section.

E18. Memory Type Undefined for Nonmemory Operations

Problem: The Memory Type field for nonmemory transactions such as I/O and Special Cycles are undefined. Although the Memory Type attribute for nonmemory operations logically should (and usually does) manifest itself as UC, this feature is not designed into the implementation and is therefore inconsistent.

Implication: Bus agents may decode a non-UC memory type for nonmemory bus transactions.

Workaround: Bus agents must consider transaction type to determine the validity of the Memory Type field for a transaction.

Status: For the steppings affected see the *Summary of Changes* at the beginning of this section.

E19. Infinite Snoop Stall During L2 Initialization of MP Systems

Problem: It is possible for snoop traffic generated on the system bus while a processor is executing its L2 cache initialization routine to cause the initializing processor to hang.

Implication: A DP (2-way) system which does not suppress snoop traffic while L2 caches are being initialized may hang during this initialization sequence.

Workaround: The system BIOS can create an execution environment which allows processors to initialize their L2 caches without the system generating any snoop traffic on the bus.

Below is a pseudo-code fragment, designed explicitly for a two-processor system, that uses a serial algorithm to initialize each processor's L2 cache:

```

Suppress_all_I/O_traffic()
K = 0;
while (K <= 1)
{
/* Obtain current value of K. This forces both Temp and K into */
/* the L1 cache. Note that Temp could also be maintained in a */
/* general purpose register. */

Temp = K;
Wait_until_all_processors_are_signed_in_at_barrier()
if ( logical_proc_APIC_id == K ) {
{
wait_10_usecs_delay_loop(); /* this time delay, required */
/* in the worst case, allows */
/* the barrier semaphore to */
/* settle to shared state. */
Initialize L2 cache
K++
}
else
while (Temp == K);
}
}

```

This algorithm prevents bus snoop traffic from the other processors, which would otherwise cause the initializing processor to hang. The algorithm assumes that the L1 cache is enabled (the Temp and K variables must be cached by each processor). Also, the Memory Type Range Register (MTRR) for the data segment must be set to WB (writeback) memory type.

Status: For the steppings affected see the *Summary of Changes* at the beginning of this section.

E20. FP Data Operand Pointer May Not Be Zero After Power On or Reset

Problem: The FP Data Operand Pointer, as specified, should be reset to zero upon power on or Reset by the processor. Due to this erratum, the FP Data Operand Pointer may be nonzero after power on or Reset.

Implication: Software which uses the FP Data Operand Pointer and count on its value being zero after power on or Reset without first executing an FINIT/FNINIT instruction will use an incorrect value, resulting in incorrect behavior of the software.

Workaround: Software should follow the recommendation in Section 8.2 of the *Intel Architecture Software Developer's Manual, Volume 3: System Programming Guide* (Order Number 243192). This recommendation states that if the FPU will be used, software-initialization code should execute an FINIT/FNINIT instruction following a hardware reset. This will correctly clear the FP Data Operand Pointer to zero.

Status: For the steppings affected see the *Summary of Changes* at the beginning of this section.

E21. MOVD Following Zeroing Instruction Can Cause Incorrect Result

Problem: An incorrect result may be calculated after the following circumstances occur:

1. A register has been zeroed with either a SUB reg, reg instruction or an XOR reg, reg instruction,
2. A value is moved with sign extension into the same register's lower 16 bits; or a signed integer multiply is performed to the same register's lower 16 bits,
3. This register is then copied to an MMX™ technology register using the MOVD instruction prior to any other operations on the sign-extended value.

Specifically, the sign may be incorrectly extended into bits 16-31 of the MMX technology register. Only the MMX technology register is affected by this erratum.

The erratum only occurs when the three following steps occur in the order shown. The erratum may occur with up to 40 intervening instructions that do not modify the sign-extended value between steps 2 and 3.

1. XOR EAX, EAX
or SUB EAX, EAX
2. MOVSX AX, BL
or MOVSX AX, byte ptr <memory address> or MOVSX AX, BX
or MOVSX AX, word ptr <memory address> or IMUL BL (AX implicit, opcode F6 /5)
or IMUL byte ptr <memory address> (AX implicit, opcode F6 /5) or IMUL AX, BX (opcode 0F AF /r)
or IMUL AX, word ptr <memory address> (opcode 0F AF /r) or IMUL AX, BX, 16 (opcode 6B /r ib)
or IMUL AX, word ptr <memory address>, 16 (opcode 6B /r ib) or IMUL AX, 8 (opcode 6B /r ib)
or IMUL AX, BX, 1024 (opcode 69 /r iw)
or IMUL AX, word ptr <memory address>, 1024 (opcode 69 /r iw) or IMUL AX, 1024 (opcode 69 /r iw)
or CBW
3. MOVD MM0, EAX

Note that the values for immediate byte/words are merely representative (i.e., 8, 16, 1024) and that any value in the range for the size may be affected. Also, note that this erratum may occur with "EAX" replaced with any 32-bit general-purpose register, and "AX" with the corresponding 16-bit version of that replacement. "BL" or "BX" can be replaced with any 8-bit or 16-bit general-purpose register. The CBW and IMUL (opcode F6 /5) instructions are specific to the EAX register only.

In the example, EAX is forced to contain 0 by the XOR or SUB instructions. Since the four types of the MOVSX or IMUL instructions and the CBW instruction modify only bits 15:8 of EAX by sign extending the lower 8 bits of EAX, bits 31:16 of EAX should always contain 0. This implies that when MOVD copies EAX to MM0, bits 31:16 of MM0 should also be 0. Under certain scenarios, bits 31:16 of MM0 are not 0, but are replicas of bit 15 (the 16th bit) of AX. This is noticeable when the value in AX after the MOVSX, IMUL, or CBW instruction is negative, i.e., bit 15 of AX is a 1.

When AX is positive (bit 15 of AX is a 0), MOVD will always produce the correct answer. If AX is negative (bit 15 of AX is a 1), MOVD may produce the right answer or the wrong answer depending on the point in time when the MOVD instruction is executed in relation to the MOVSX, IMUL, or CBW instruction.

Implication: The effect of incorrect execution will vary from unnoticeable, due to the code sequence discarding the incorrect bits, to an application failure. If the MMX technology-enabled application in which MOVD is used to manipulate pixels, it is possible for one or more pixels to exhibit the wrong color or position momentarily. It is also possible for a computational application that uses the MOVD instruction in the manner described above to produce incorrect data. Note that this data may cause an unexpected page fault or general protection fault.

Workaround: There are two possible workarounds for this erratum:

1. Rather than using the MOVXS-MOVD, IMUL-MOVD, or CBW-MOVD pairing to handle one variable at a time, use the sign extension capabilities (PSRAW, etc.) within MMX technology for operating on multiple variables. This would result in higher performance as well.
2. Insert another operation that modifies or copies the sign-extended value between the MOVSX/IMUL/CBW instruction and the MOVD instruction as in the example below:

```
XOR EAX, EAX (or SUB EAX, EAX)
MOVXS AX, BL (or other MOVXS, other IMUL or CBW instruction)
*MOV EAX, EAX
MOVD MM0, EAX
```

*Note: MOV EAX, EAX is used here as it is fairly generic. Again, EAX can be any 32-bit register.

Status: For the steppings affected see the *Summary of Changes* at the beginning of this section.

E22. Premature Execution of a Load Operation Prior to Exception Handler Invocation

Problem: This erratum can occur with any of the following situations:

1. If an instruction that performs a memory load causes a code segment limit violation,
2. If a waiting floating-point instruction or MMX™ instruction that performs a memory load has a floating-point exception pending, or
3. If an MMX instruction that performs a memory load and has either CR0.EM =1 (Emulation bit set), or a floating-point Top-of-Stack (FP TOS) not equal to 0, or a DNA exception pending.

If any of the above circumstances occur it is possible that the load portion of the instruction will have executed before the exception handler is entered.

Implication: In normal code execution where the target of the load operation is to write back memory there is no impact from the load being prematurely executed, nor from the restart and subsequent re-execution of that instruction by the exception handler. If the target of the load is to uncached memory that has a system side-effect, restarting the instruction may cause unexpected system behavior due to the repetition of the side-effect.

Workaround: Code which performs loads from memory that has side-effects can effectively workaround this behavior by using simple integer-based load instructions when accessing side-effect memory and by ensuring that all code is written such that a code segment limit violation cannot occur as a part of reading from side-effect memory.

Status: For the steppings affected see the *Summary of Changes* at the beginning of this section.

E23. Read Portion of RMW Instruction May Execute Twice

Problem: When the Pentium III processor executes a read-modify-write (RMW) arithmetic instruction, with memory as the destination, it is possible for a page fault to occur during the execution of the store on the memory operand after the read operation has completed but before the write operation completes.

If the memory targeted for the instruction is UC (uncached), memory will observe the occurrence of the initial load before the page fault handler and again if the instruction is restarted.

Implication: This erratum has no effect if the memory targeted for the RMW instruction has no side-effects. If, however, the load targets a memory region that has side-effects, multiple occurrences of the initial load may lead to unpredictable system behavior.

Workaround: Hardware and software developers who write device drivers for custom hardware that may have a side-effect style of design should use simple loads and simple stores to transfer data to and from the device. Then, the memory location will simply be read twice with no additional implications.

Status: For the steppings affected see the *Summary of Changes* at the beginning of this section.

E24. MC2_STATUS MSR Has Model-Specific Error Code and Machine Check Architecture Error Code Reversed

Problem: The *Intel Architecture Software Developer's Manual, Volume 3: System Programming Guide*, documents that for the MC_i_STATUS MSR, bits 15:0 contain the MCA (machine-check architecture) error code field, and bits 31:16 contain the model-specific error code field. However, for the MC2_STATUS MSR, these bits have been reversed. For the MC2_STATUS MSR, bits 15:0 contain the model-specific error code field and bits 31:16 contain the MCA error code field.

Implication: A machine check error may be decoded incorrectly if this erratum on the MC2_STATUS MSR is not taken into account.

Workaround: When decoding the MC2_STATUS MSR, reverse the two error fields.

Status: For the steppings affected see the *Summary of Changes* at the beginning of this section.

E25. Mixed Cacheability of Lock Variables Is Problematic in MP Systems

Problem: This errata only affects multiprocessor systems where a lock variable address is marked cacheable in one processor and uncacheable in any others. The processors which have it marked uncacheable may stall indefinitely when accessing the lock variable. The stall is only encountered if:

- One processor has the lock variable cached, and is attempting to execute a cache lock.
- If the processor which has that address cached has it cached in its L2 only.
- Other processors, meanwhile, issue back to back accesses to that same address on the bus.

Implication: MP systems where all processors either use cache locks or consistent locks to uncacheable space will not encounter this problem. If, however, a lock variable's cacheability varies in different processors, and several processors are all attempting to perform the lock simultaneously, an indefinite stall may be experienced by the processors which have it marked uncacheable in locking the variable (if the conditions above are satisfied). Intel has only encountered this problem in focus testing with artificially generated external events. Intel has not currently identified any commercial software which exhibits this problem.

Workaround: Follow a homogenous model for the memory type range registers (MTRRs), ensuring that all processors have the same cacheability attributes for each region of memory; do not use locks whose memory type is cacheable on one processor, and uncacheable on others. Avoid page table aliasing, which may produce a nonhomogenous memory model.

Status: For the steppings affected see the *Summary of Changes* at the beginning of this section.

E26. MOV With Debug Register Causes Debug Exception

Problem: When in V86 mode, if a MOV instruction is executed on debug registers, a general-protection exception (#GP) should be generated, as documented in the *Intel Architecture Software Developer's Manual, Volume 3: System Programming Guide*, Section 14.2. However, in the case when the general detect enable flag (GD) bit is set, the observed behavior is that a debug exception (#DB) is generated instead.

Implication: With debug-register protection enabled (i.e., the GD bit set), when attempting to execute a MOV on debug registers in V86 mode, a debug exception will be generated instead of the expected general-protection fault.

Workaround: In general, operating systems do not set the GD bit when they are in V86 mode. The GD bit is generally set and used by debuggers. The debug exception handler should check that the exception did not occur in V86 mode before continuing. If the exception did occur in V86 mode, the exception may be directed to the general-protection exception handler.

Status: For the steppings affected see the *Summary of Changes* at the beginning of this section.

E27. Upper Four PAT Entries Not Usable With Mode B or Mode C Paging

Problem: The Page Attribute Table (PAT) contains eight entries, which must all be initialized and considered when setting up memory types for the Pentium III processor. However, in Mode B or Mode C paging, the upper four entries do not function correctly for 4-Kbyte pages. Specifically, bit 7 of page table entries that translate addresses to 4-Kbyte pages should be used as the upper bit of a 3-bit index to determine the PAT entry that specifies the memory type for the page. When Mode B (CR4.PSE = 1) and/or Mode C (CR4.PAE) are enabled, the processor forces this bit to zero when determining the memory type regardless of the value in the page table entry. The upper four entries of the PAT function correctly for 2-Mbyte and 4-Mbyte large pages (specified by bit 12 of the page directory entry for those translations).

Implication: Only the lower four PAT entries are useful for 4-KB translations when Mode B or C paging is used. In Mode A paging (4-Kbyte pages only), all eight entries may be used. All eight entries may be used for large pages in Mode B or C paging.

Workaround: None identified.

Status: For the steppings affected see the *Summary of Changes* at the beginning of this section.

E28. Data Breakpoint Exception in a Displacement Relative Near Call May Corrupt EIP

Problem: If a misaligned data breakpoint is programmed to the same cache line as the memory location where the stack push of a near call is performed and any data breakpoints are enabled, the processor will update the stack and ESP appropriately, but may skip the code at the destination of the call. Hence, program execution will continue with the next instruction immediately following the call, instead of the target of the call.

Implication: The failure mechanism for this erratum is that the call would not be taken; therefore, instructions in the called subroutine would not be executed. As a result, any code relying on the execution of the subroutine will behave unpredictably.

Workaround: Whether enabled or not, do not program a misaligned data breakpoint to the same cache line on the stack where the push for the near call is performed.

Status: For the steppings affected see the *Summary of Changes* at the beginning of this section.

E29. RDMSR or WRMSR to Invalid MSR Address May Not Cause GP Fault

Problem: The RDMSR and WRMSR instructions allow reading or writing of MSRs (Model Specific Registers) based on the index number placed in ECX. The processor should reject access to any reserved or unimplemented MSRs by generating #GP(0). However, there are some invalid MSR addresses for which the processor will not generate #GP(0).

Implication: For RDMSR, undefined values will be read into EDX:EAX. For WRMSR, undefined processor behavior may result.

Workaround: Do not use invalid MSR addresses with RDMSR or WRMSR.

Status: For the steppings affected see the *Summary of Changes* at the beginning of this section.

E30. SYSENTER/SYSEXIT Instructions Can Implicitly Load “Null Segment Selector” to SS and CS Registers

Problem: According to the processor specification, attempting to load a null segment selector into the CS and SS segment registers should generate a General Protection Fault (#GP). Although loading a null segment selector to the other segment registers is allowed, the processor will generate an exception when the segment register holding a null selector is used to access memory.

However, the SYSENTER instruction can implicitly load a null value to the SS segment selector. This can occur if the value in SYSENTER_CS_MSR is between FFF8h and FFFBh when the SYSENTER instruction is executed. This behavior is part of the SYSENTER/SYSEXIT instruction definition; the content of the SYSTEM_CS_MSR is always incremented by 8 before it is loaded into the SS. This operation will set the null bit in the segment selector if a null result is generated, but it does not generate a #GP on the SYSENTER instruction itself. An exception will be generated as expected when the SS register is used to access memory, however.

The SYSEXIT instruction will also exhibit this behavior for both CS and SS when executed with the value in SYSENTER_CS_MSR between FFF0h and FFF3h, or between FFE8h and FFEb, inclusive.

Implication: These instructions are intended for operating system use. If this erratum occurs (and the OS does not ensure that the processor never has a null segment selector in the SS or CS segment registers), the processor's behavior may become unpredictable, possibly resulting in system failure.

Workaround: Do not initialize the SYSTEM_CS_MSR with the values between FFF8h and FFFBh, FFF0h and FFF3h, or FFE8h and FFEb before executing SYSENTER or SYSEXIT.

Status: For the steppings affected see the *Summary of Changes* at the beginning of this section.

E31. PRELOAD Followed by EXTEST Does Not Load Boundary Scan Data

Problem: According to the IEEE 1149.1 Standard, the EXTEST instruction would use data “typically loaded onto the latched parallel outputs of boundary-scan shift-register stages using the SAMPLE/PRELOAD instruction prior to the selection of the EXTEST instruction.” As a result of this erratum, this method cannot be used to load the data onto the outputs.

Implication: Using the PRELOAD instruction prior to the EXTEST instruction will not produce expected data after the completion of EXTEST.

Workaround: None identified.

Status: For the steppings affected see the *Summary of Changes* at the beginning of this section.

E32. Far Jump to New TSS With D-bit Cleared May Cause System Hang

Problem: A task switch may be performed by executing a far jump through a task gate or to a new Task State Segment (TSS) directly. Normally, when such a jump to a new TSS occurs, the D-bit (which indicates that the page referenced by a Page Table Entry (PTE) has been modified) for the PTE which maps the location of the previous TSS will already be set, and the processor will operate as expected. However, if the D-bit is clear at the time of the jump to the new TSS, the processor will hang.

Implication: If an OS is used which can clear the D-bit for system pages, and which jumps to a new TSS on a task switch, then a condition may occur which results in a system hang. Intel has not identified any commercial software which may encounter this condition; this erratum was discovered in a focused testing environment.

Workaround: Ensure that OS code does not clear the D-bit for system pages (including any pages that contain a task gate or TSS). Use task gates rather than jumping to a new TSS when performing a task switch.

Status: For the steppings affected see the *Summary of Changes* at the beginning of this section.

E33. INT 1 Instruction Handler Execution Could Generate a Debug Exception

Problem: If the processor's general detect enable flag is set and an explicit call is made to the interrupt procedure via the INT 1 instruction, the general detect enable flag should be cleared prior to entering the handler. As a result of this erratum, the flag is not cleared prior to entering the handler. If an access is made to the debug registers while inside of the handler, the state of the general detect enable flag will cause a second debug exception to be taken. The second debug exception clears the general detect enable flag and returns control to the handler which is now able to access the debug registers.

Implication: This erratum will generate an unexpected debug exception upon accessing the debug registers while inside of the INT 1 handler.

Workaround: Ignore the second debug exception that is taken as a result of this erratum.

Status: For the steppings affected see the *Summary of Changes* at the beginning of this section.

E34. COMISS/UCOMISS May Not Update Eflags Under Certain Conditions

Problem: COMISS/UCOMISS instructions compare the least significant pairs of packed single-precision floating-point numbers and set the ZF, PF, and CF bits in the EFLAGS register accordingly (the OF, SF, and AF bits are cleared). Under certain conditions when a memory location is loaded into cache, the EFLAGS may not get set.

Implication: The result of the incorrect status of the EFLAGS may range from no effect to an unexpected application/OS behavior.

Workaround: It is possible for BIOS code to contain a workaround for this erratum.

Status: For the steppings affected see the *Summary of Changes* at the beginning of this section.

E35. Transmission Error on Cache Read

Problem: During reads of the L2 cache, the processor may use certain L2 cache optimizations that may result in a data transmission error.

Implication: Data corruption caused by this erratum will result in unpredictable system behavior.

Workaround: It is possible for BIOS code to contain a workaround for this erratum.

Status: For the steppings affected see the *Summary of Changes* at the beginning of this section.



E36. Potential Loss of Data Coherency During MP Data Ownership Transfer

Problem: In MP systems, processors may be sharing data in different cache lines, referenced as line A and line B in the discussion below. When this erratum occurs (with the following example given for a 2-way MP system with processors noted as 'P0' and 'P1'), P0 contains a shared copy of line B in its L1. P1 has a shared copy of Line A. Each processor must manage the necessary invalidation and snoop cycles before that processor can modify and source the results of any internal writes to the other processor.

There exists a narrow timing window when, if P1 requests a copy of line B it may be supplied by P0 in an Exclusive state which allows P1 to modify the contents of the line with no further external invalidation cycles. In this narrow window P0 may also retire instructions that use the original data present before P1 performed the modification

Implication: Multiprocessor or threaded application synchronization, required for low-level data sharing, that is implemented via operating system provided synchronization constructs are not affected by this erratum. Applications which rely upon the usage of locked semaphores rather than memory ordering are also unaffected. Uniprocessor systems are not affected by this erratum. If the erratum does occur one processor may execute software with the stale data that was present from the previous shared state rather than the data written more recently by another processor.

Workaround: Deterministic barriers beyond which program variables will not be modified can be achieved via the usage of locked semaphore operations. These should effectively prevent the occurrence of this erratum.

Status: For the steppings affected see the *Summary of Changes* at the beginning of this section.

E37. Misaligned Locked Access to APIC Space Results in Hang

Problem: When the processor's APIC space is accessed with a misaligned locked access a machine check exception is expected. However, the processor's machine check architecture is unable to handle the misaligned locked access.

Implication: If this erratum occurs the processor will hang. Typical usage models for the APIC address space do not use locked accesses. This erratum will not affect systems using such a model.

Workaround: Ensure that all accesses to APIC space are aligned.

Status: For the steppings affected see the *Summary of Changes* at the beginning of this section.

E38. Floating-Point Exception Signal May Be Deferred

Problem: A one clock window exists where a pending x87 FP exception that should be signaled on the execution of a CVTPS2PI, CVTPI2PS, or CVTTPS2PI instruction may be deferred to the next waiting floating-point instruction or instruction that would change MMX™ register state.

Implication: If this erratum occurs the floating-point exception will not be handled as expected.

Workaround: Applications that follow Intel programming guidelines (empty all x87 registers before executing MMX technology instructions) will not be affected by this erratum.

Status: For the steppings affected see the *Summary of Changes* at the beginning of this section.

E39. *Memory Ordering Based Synchronization May Cause a Livelock Condition in MP Systems*

Problem: In an MP environment, the following sequence of code (or similar code) in two processors (P0 and P1) may cause them to each enter an infinite loop (livelock condition):

P0	MOV [xyz], EAX (1)	P1	wait1: MOV EBX, [abc] (2)
	.		CMP EBX, val1 (3)
	.		JNE wait1 (4)
	.		
	MOV [abc], val1 (6)		MOV [abc], val2 (5)
wait0:	MOV EBX, [abc] (7)		
	CMP EBX, val2 (8)		
	JNE wait0 (9)		

NOTE

The EAX and EBX can be any general-purpose register. Addresses [abc] and [xyz] can be any location in memory and must be in the same bank of the L1 cache. Variables “val1” and “val2” can be any integer.

The algorithm above involves processors P0 and P1, each of which use loops to keep them synchronized with each other. P1 is looping until instruction (6) in P0 is globally observed. Likewise, P0 will loop until instruction (5) in P1 is globally observed.

The P6 architecture allows for instructions (1) and (7) in P0 to be dispatched to the L1 cache simultaneously. If the two instructions are accessing the same memory bank in the L1 cache, the load (7) will be given higher priority and will complete, blocking instruction (1).

Instructions (8) and (9) may then execute and retire, placing the instruction pointer back to instruction (7). This is due to the condition at the end of the “wait0” loop being false. The livelock scenario can occur if the timing of the wait0 loop execution is such that instruction (7) in P0 is ready for completion every time that instruction (1) tries to complete. Instruction (7) will again have higher priority, preventing the data ([xyz]) in instruction (1) from being written to the L1 cache. This causes instruction (6) in P0 to not complete and the sequence “wait0” to loop infinitely in P0.

A livelock condition also occurs in P1 because instruction (6) in P0 does not complete (blocked by instruction (1) not completing). The problem with this scenario is that P0 should eventually allow for instruction (1) to write its data to the L1 cache. If this occurs, the data in instruction (6) will be written to memory, allowing the conditions in both loops to be true.

Implication: Both processors will be stuck in an infinite loop, leading to a hang condition. Note that if P0 receives any interrupt, the loop timing will be disrupted such that the livelock will be broken. The system timer, a keystroke, or mouse movement can provide an interrupt that will break the livelock.

Workaround: Use a LOCK instruction to force P0 to execute instruction (6) before instruction (7).

Status: For the steppings affected see the *Summary of Changes* at the beginning of this section.



E40. System Bus Address Parity Generator May Report False AERR#

Problem: The processor's address parity error detection circuit may fail to meet its frequency timing specification under certain environmental conditions. At the high end of the temperature specification and/or the low end of the voltage range, the processor may report false address parity errors.

Implication: If the system has AERR# drive enabled (bit [3] of the EBL_CR_POWERON register set to '1') spurious address detection and reporting may occur. In some system configurations, BINIT# may be asserted on the system bus. This may cause some systems to generate a machine check exception and in others may cause a reboot.

Workaround: Disable AERR# drive from the processor. AERR# drive may be disabled by clearing bit [3] in the EBL_CR_POWERON register. In addition, if the chipset allows, AERR# drive should be enabled from the chipset and AERR# observation enabled on the processor. AERR# observation on the processor is enabled by asserting A8# on the active-to-inactive transition of RESET#.

Status: For the processor part numbers affected see the "Pentium® III Processor Identification and Packaging Information" table in the General Information section.

E41. System Bus ECC Not Functional With 2:1 Ratio

Problem: If a processor is underclocked at a core frequency to system bus frequency ratio of 2:1 and system bus ECC is enabled, the system bus ECC detection and correction will negatively affect internal timing dependencies.

Implication: If system bus ECC is enabled, and the processor is underclocked at a 2:1 ratio, the system may behave unpredictably due to these timing dependencies.

Workaround: All bus agents that support system bus ECC must disable it when a 2:1 ratio is used.

Status: For the steppings affected see the *Summary of Changes* at the beginning of this section.

E42. Processor May Assert DRDY# on a Write With No Data

Problem: When a MASKMOVQ instruction is misaligned across a chunk boundary in a way that one chunk has a mask of all 0's, the processor will initiate two partial write transactions with one having all byte enables deasserted. Under these conditions, the expected behavior of the processor would be to perform both write transactions, but to deassert DRDY# during the transaction which has no byte enables asserted. As a result of this erratum, DRDY# is asserted even though no data is being transferred.

Implication: The implications of this erratum depend on the bus agent's ability to handle this erroneous DRDY# assertion. If a bus agent cannot handle a DRDY# assertion in this situation, or attempts to use the invalid data on the bus during this transaction, unpredictable system behavior could result.

Workaround: A system which can accept a DRDY# assertion during a write with no data will not be affected by this erratum. In addition, this erratum will not occur if the MASKMOVQ is aligned.

Status: For the steppings affected see the *Summary of Changes* at the beginning of this section.

E43. GP# Fault on WRMSR to ROB_CR_BKUPTMPDR6

Problem: Writing a '1' to unimplemented bit(s) in the ROB_CR_BKUPTMPDR6 MSR (offset 1E0h) will result in a general protection fault (GP#).

Implication: The normal process used to write an MSR is to read the MSR using RDMSR, modify the bit(s) of interest, and then to write the MSR using WRMSR. Because of this erratum, this process may result in a GP# fault when used to modify the ROB_CR_BKUPTMPDR6 MSR.

Workaround: When writing to ROB_CR_BKUPTMPDR6 all unimplemented bits must be '0.' Implemented bits may be set as '0' or '1' as desired.

Status: For the steppings affected see the *Summary of Changes* at the beginning of this section.

E44. Machine Check Exception May Occur Due to Improper Line Eviction in the IFU

Problem: The Pentium III processor is designed to signal an unrecoverable Machine Check Exception (MCE) as a consistency checking mechanism. Under a complex set of circumstances involving multiple speculative branches and memory accesses there exists a one cycle long window in which the processor may signal a MCE in the Instruction Fetch Unit (IFU) because instructions previously decoded have been evicted from the IFU. The one cycle long window is opened when an opportunistic fetch receives a partial hit on a previously executed but not as yet completed store resident in the store buffer. The resulting partial hit erroneously causes the eviction of a line from the IFU at a time when the processor is expecting the line to still be present. If the MCE for this particular IFU event is disabled, execution will continue normally.

Implication: While this erratum may occur on a system with any number of Pentium III processors, the probability of occurrence increases with the number of processors. If this erratum does occur, a machine check exception will result. Note systems that implement an operating system that does not enable the Machine Check Architecture will be completely unaffected by this erratum (e.g., Windows* 95 and Windows 98).

Workaround: It is possible for BIOS code to contain a workaround for this erratum.

Status: For the steppings affected see the *Summary of Changes* at the beginning of this section.

E45. Performance Counters Include Streaming SIMD Extensions L1 Prefetch

Problem: The processor allows the measurement of the frequency and duration of numerous different internal and bus related events (see *Intel Architecture Software Developer's Manual, Volume 3*, for more details). The Streaming SIMD Extension (SSE) architecture provides a mechanism to pre-load data into the L1 cache, bypassing the L2 cache. The number of these L1 pre-loads measured by the performance monitoring logic will incorrectly be included in the count of "L2_LINES_IN" (24H) events and "L2_LINES_OUT" (26H) events.

Implication: If application software is run which utilizes the SSE L1 prefetch feature, the count of "L2_LINES_IN" (24H) and "L2_LINES_OUT" (26H) will read a value that is greater than the correct value.

Workaround: The correct value of "L2_LINES_IN" and "L2_LINES_OUT" may be calculated by subtracting the value of the "MMX_PRE_MISS" (4BH) from each of these registers.

Status: For the steppings affected see the *Summary of Changes* at the beginning of this section.



E46. Snoop Request May Cause DBSY# Hang

Problem: A small window of time exists in which a snoop request originating from a bus agent to a processor with one or more outstanding memory transactions may cause the processor to assert DBSY# without issuing a corresponding bus transaction, causing the processor to hang (livelock). The exact circumstances are complex, and include the relative timing of internal processor functions with the snoop request from a bus agent.

Implication: This erratum may occur on a system with any number of processors. However, the probability of occurrence increases with the number of processors. If this erratum does occur, the system will hang with DBSY# asserted. At this point, the system requires a hard reset.

Workaround: It is possible for BIOS code to contain a workaround for this erratum.

Status: For the steppings affected see the *Summary of Changes* at the beginning of this section.

E47. Lower Bits of SMRAM SMBASE Register Cannot Be Written With an ITP

Problem: The System Management Base (SMBASE) register (7EF8H) stores the starting address of the System Management RAM (SMRAM). This register is used by the processor when it is in System Management Mode (SMM), and its contents serve as the memory base for code execution and data storage. The 32-bit SMBASE register can normally be programmed to any value. When programmed with an In-Target Probe (ITP), however, any attempt to set the lower 11 bits of SMBASE to anything other than zeros via the WRMSR instruction will cause the attempted write to fail.

Implication: When set via ITP, any attempt to relocate SMRAM space must be made with 2-KB alignment.

Workaround: None identified

Status: For the steppings affected see the *Summary of Changes* at the beginning of this section.

E48. Task Switch Caused by Page Fault May Cause Wrong PTE and PDE Access Bit to Be Set

Problem: If an operating system executes a task switch via a Task State Segment (TSS), and the TSS is wholly or partially located within a clean page (A and D bits clear) and the GDT entry for the new TSS is either misaligned across a cache line boundary or is in a clean page, the accessed and dirty bits for an incorrect page table/directory entry may be set.

Implication: An operating system which uses hardware task switching (or hardware task management) may encounter this erratum. The effect of the erratum depends on the alignment of the TSS and ranges from no anomalous behavior to unexpected errors.

Workaround: The operating system could align all TSSs to be within page boundaries and set the A and D bits for those pages to avoid this erratum. The operating system may alternately use software task management.

Status: For the steppings affected see the *Summary of Changes* at the beginning of this section.

E49. Unsynchronized Cross-Modifying Code Operations Can Cause Unexpected Instruction Execution Results

Problem: The act of one processor, or system bus master, writing data into a currently executing code segment of a second processor with the intent of having the second processor execute that data as code is called cross-modifying code (XMC). XMC that does not force the second processor to execute a synchronizing instruction, prior to execution of the new code, is called unsynchronized XMC.

Software using unsynchronized XMC to modify the instruction byte stream of a processor can see unexpected instruction execution from the processor that is executing the modified code.

Implication: In this case, the phrase "unexpected execution behavior" encompasses the generation of most of the exceptions listed in the *Intel Architecture Software Developer's Manual Volume 3: System Programming Guide*, including a General Protection Fault (GPF). In the event of a GPF the application executing the unsynchronized XMC operation would be terminated by the operating system.

Workaround: In order to avoid this erratum, programmers should use the XMC synchronization algorithm as detailed in the *Intel Architecture Software Developer's Manual Volume 3: System Programming Guide*, Section 7.1.3.

Status: For the steppings affected see the *Summary of Changes* at the beginning of this section.

E50. Processor Will Erroneously Report a BIST Failure

Problem: If the processor performs BIST at power-up, the EAX register is normally cleared (0H) when the processor passes. The processor will erroneously report a non-zero value (signaling a BIST failure) even if BIST passes.

Implication: The processor will incorrectly signal an error after BIST is performed.

Workaround: The system BIOS should ignore the BIST results in the EAX register.

Status: For the steppings affected see the *Summary of Changes* at the beginning of this section.

E51. Noise Sensitivity Issue on Processor SMI# Pin

Problem: Post silicon characterization has demonstrated a greater than expected sensitivity to noise on the processor's SMI# input, which may result in spurious SMI# interrupts.

Implication: BIOS/SMM code that is capable of handling spurious SMI events will report a spurious SMI#, but should not be negatively impacted by this erratum. Systems whose BIOS code cannot handle spurious SMI events may fail, resulting in a system hang or other anomalous behavior.

Spurious SMI# interrupts should be controlled on the system board regardless of BIOS implementation.

Workaround: Possible workarounds that may reduce or eliminate the occurrence of the spurious SMI# interrupts include:

1. Use a lower effective pull-up resistance on the SMI# pin. This resistor must meet the specifications of the component driving the SMI# signal.
2. Externally condition the SMI# signal prior to providing it to the processor's SMI# pin.

These workarounds should be evaluated on a design-by-design basis.

Status: For the steppings affected see the *Summary of Changes* at the beginning of this section.



E52. Limitation On Cache Line ECC Detection and Correction

Problem: ECC can detect and correct up to four single-bit ECC errors per cache line. However, the processor will only detect and correct one single-bit ECC error per cache line. While all ECC errors will be detected, multiple single bit errors will be incorrectly reported as uncorrectable double bit errors, rather than correctable single bit errors.

Implication: The processor may report fewer single bit ECC errors and more double bit ECC errors than previous processors.

Workaround: None identified

Status: For the steppings affected see the *Summary of Changes* at the beginning of this section.

E53. L2_LD and L2_M_LINES_OUTM Performance-Monitoring Counters Do Not Work

Problem: The L2_LD (29H) and L2_M_LINES_OUTM (27H) Performance-Monitoring counters are used to monitor L2 cache line activity. These counters incorrectly count their respective events.

Implication: These counters will report incorrect data.

Workaround: None identified

Status: For the steppings affected see the *Summary of Changes* at the beginning of this section.

E54. IFU/DCU Deadlock May Cause System Hang

Problem: An internal deadlock situation may occur in systems with multiple bus agents, with a failure signature such that a processor either asserts DBSY# without issuing the corresponding data, or fails to respond to a snoop request from another bus agent. Should this erratum occur, the affected processor ceases code execution and the system will hang.

The specific circumstances surrounding the occurrence of this erratum are:

1. A locked operation to the Data Cache Unit (DCU) is in process.
2. A snoop occurs, but cannot complete due to the ongoing locked operation.
3. The presence of the snoop prevents pending Instruction Fetch Unit (IFU) requests from completing.
4. The IFU requests are periodically restarted.

The continued IFU restart attempts create additional DCU snoops, which prevent the in-process locked operation from completing, keeping the DCU locked.

Implication: The system may hang.

Workaround: It is possible for BIOS code to contain a workaround for this erratum.

Status: For the steppings affected see the *Summary of Changes* at the beginning of this section.

E55. L2_DBUS_BUSY Performance Monitoring Counter Will Not Count Writes

Problem: The L2_DBUS_BUSY (22H) performance monitoring counter is intended to count the number of cycles during which the L2 data bus is in use. For some steppings of the processor, the L2_DBUS_BUSY counter will not be incremented during write cycles and therefore will only reflect the number of L2 data bus cycles resulting from cache reads.

Implication: The L2_DBUS_BUSY event counts only L2 read cycles.

Workaround: None identified

Status: For the steppings affected see the *Summary of Changes* at the beginning of this section.

E56. Incorrect Sign May Occur On X87 Result Due To Indefinite QNaN Result From Streaming SIMD Extensions Multiply

Problem: It is possible that a negative sign bit may be incorrectly applied to the result of an X87 floating-point operation if it is closely preceded by a Streaming SIMD Extensions (SSE) multiply operation. In order for this erratum to occur, the Streaming SIMD Extensions multiply operation must result in an Indefinite Quiet Not-a-Number (QNaN). Operations such as multiplying zero by infinity will result in an Indefinite QNaN result.

Implication: If this erratum occurs, the result of an X87 floating-point instruction, which should be positive, will instead be negative.

Workaround: It is possible for BIOS code to contain a workaround for this erratum.

Status: For the steppings affected see the *Summary of Changes* at the beginning of this section.

E57. Deadlock May Occur Due To Illegal-Instruction/Page-Miss Combination

Problem: Intel's 32-bit Instruction Set Architecture (ISA) utilizes most of the available op-code space; however some byte combinations remain undefined and are considered illegal instructions. Intel processors detect the attempted execution of illegal instructions and signal an exception. This exception is handled by operating system and/or application software.

Under a complex set of internal and external conditions involving illegal instructions, a deadlock may occur within the processor. The necessary conditions for the deadlock involve:

1. Execution of the illegal instruction.
2. Two-page table walks occur within a narrow timing window coincident with the illegal instruction.

Implication: The illegal instructions involved in this erratum are unusual and invalid byte combinations that are not useful to application software or operating systems. These combinations are not normally generated in the course of software programming, nor are such sequences known by Intel to be generated in commercially available software and tools. Development tools (compilers, assemblers) do not generate this type of code sequence, and will normally flag such a sequence as an error. If this erratum occurs, the processor deadlock condition will occur and result in a system hang. Code execution cannot continue without a system RESET.

Workaround: None identified

Status: For the steppings affected see the *Summary of Changes* at the beginning of this section.

E58. MASKMOVQ Instruction Interaction with String Operation May Cause Deadlock

Problem: Under the following scenario, combined with a specific alignment of internal events, the processor may enter a deadlock condition:

1. A store operation completes, leaving a write-combining (WC) buffer partially filled.
2. The target of a subsequent MASKMOVQ instruction is split across a cache line.
3. The data in (2) above results in a hit to the data in the WC buffer in (1).

Implication: If this erratum occurs, the processor deadlock condition will occur and result in a system hang. Code execution cannot continue without a system RESET.

Workaround: It is possible for BIOS code to contain a workaround for this erratum.

Status: For the steppings affected see the *Summary of Changes* at the beginning of this section.

E59 MOVD, CVTSI2SS, or PINSRW Following Zeroing Instruction Can Cause Incorrect Result

Problem: An incorrect result may be calculated after the following circumstances occur:

1. A register has been zeroed with either a SUB reg, reg instruction, or an XOR reg, reg instruction.
2. A value is moved with sign extension into the same register's lower 16 bits; or a signed integer multiply is performed to the same register's lower 16 bits.
3. The register is then copied to an MMX™ technology register using the MOVD, or converted to single precision floating-point and moved to an MMX technology register using the CVTSI2SS instruction prior to any other operations on the sign-extended value, or inserted into an MMX™ technology register using the PINSRW instruction.

Specifically, the sign may be incorrectly extended into bits 16-31 of the MMX technology register. In the case of the PINSRW instruction, a non-zero value could be loaded into the MMX™ technology register. This erratum only affects the MMX™ technology register.

This erratum only occurs when the following three steps occur in the order shown. This erratum may occur with up to 63 (39 for Pre-CPUID 0x6BX) intervening instructions that do not modify the sign-extended value between steps 2 and 3.

1. XOR EAX, EAX
or SUB EAX, EAX
2. MOVX AX, BL
or MOVX AX, byte ptr <memory address> or MOVX AX, BX
or MOVX AX, word ptr <memory address> or IMUL BL (AX implicit, opcode F6 /5)
or IMUL byte ptr <memory address> (AX implicit, opcode F6 /5) or IMUL AX, BX (opcode 0F AF /r)
or IMUL AX, word ptr <memory address> (opcode 0F AF /r) or IMUL AX, BX, 16 (opcode 6B /r ib)
or IMUL AX, word ptr <memory address>, 16 (opcode 6B /r ib) or IMUL AX, 8 (opcode 6B /r ib)
or IMUL AX, BX, 1024 (opcode 69 /r iw)
or IMUL AX, word ptr <memory address>, 1024 (opcode 69 /r iw)
or IMUL AX, 1024 (opcode 69 /r iw) or CBW
3. MOVD MM0, EAX or CVTSI2SS MM0, EAX



Note that the values for immediate byte/words are merely representative (i.e., 8, 16, 1024) and that any value in the range for the size is affected. Also, note that this erratum may occur with "EAX" replaced with any 32-bit general-purpose register, and "AX" with the corresponding 16-bit version of that replacement. "BL" or "BX" can be replaced with any 8-bit or 16-bit general-purpose register. The CBW and IMUL (opcode F6 /5) instructions are specific to the EAX register only.

In the above example, EAX is forced to contain 0 by the XOR or SUB instructions. Since the four types of the MOVXSX or IMUL instructions and the CBW instruction only modify bits 15:8 of EAX by sign extending the lower 8 bits of EAX, bits 31:16 of EAX should always contain 0. This implies that when MOVD or CVTSS2SS copies EAX to MM0, bits 31:16 of MM0 should also be 0. In certain scenarios, bits 31:16 of MM0 are not 0, but are replicas of bit 15 (the 16th bit) of AX. This is noticeable when the value in AX after the MOVXSX, IMUL or CBW instruction is negative (i.e., bit 15 of AX is a 1).

When AX is positive (bit 15 of AX is 0), MOVD or CVTSS2SS will produce the correct answer. If AX is negative (bit 15 of AX is 1), MOVD or CVTSS2SS may produce the right answer or the wrong answer, depending on the point in time when the MOVD or CVTSS2SS instruction is executed in relation to the MOVXSX, IMUL or CBW instruction.

The PINSRW instruction can fail to correctly load a zero when used with a partial register zeroing instruction (SUB or XOR):

1. mov di, 0FFFF8914h
2. xor eax, eax
3. add ax, di
4. xor ah, ah
5. pinsrw mm1, eax, 00h

In this case, the programmer expects mm1 to contain 0014h in its least significant word. This erratum would cause MM1 to contain 8914h. The number of intervening instructions between steps 4 and 5 is the same as noted in the sign extension example above between steps 2 and 3.

Implication: The effect of incorrect execution will vary from unnoticeable, due to the code sequence discarding the incorrect bits, to an application failure.

Workaround: There are two possible workarounds for this erratum:

1. Rather than using the MOVXSX-MOVD/CVTSS2SS, IMUL-MOVD/CVTSS2SS or CBW-MOVD/CVTSS2SS pairing to handle one variable at a time, use the sign extension capabilities (PSRAW, etc.) within MMX technology for operating on multiple variables. This will also result in higher performance.

2. Insert another operation that modifies or copies the sign-extended value between the MOVXSX/IMUL/CBW instruction and the MOVD or CVTSS2SS instruction as in the example below:

```
XOR EAX, EAX (or SUB EAX, EAX)
MOVXSX AX, BL (or other MOVXSX, other IMUL or CBW instruction)
*MOV EAX, EAX
MOVD MM0, EAX or CVTSS2SS MM0, EAX
```

3. Avoid using a sub or xor to zero a partial register prior to the use of any of these three instructions. Instead, use a mov immediate (e.g. "mov ah, 0h").

*Note: MOV EAX, EAX is used here in a generic sense. Again, EAX can be substituted with any 32-bit register.

Status: For the steppings affected see the *Summary of Changes* at the beginning of this section.



E60. FLUSH# Assertion Following STPCLK# May Prevent CPU Clocks From Stopping

Problem: If FLUSH# is asserted after STPCLK# is asserted, the cache flush operation will not occur until after STPCLK# is de-asserted. Furthermore, the pending flush will prevent the processor from entering the Sleep state, since the flush operation must complete prior to the processor entering the Sleep state.

Implication: Following SLP# assertion, processor power dissipation may be higher than expected. Furthermore, if the source to the processor's input bus clock (BCLK) is removed, normally resulting in a transition to the Deep Sleep state, the processor may shutdown improperly. The ensuing attempt to wake up the processor will result in unpredictable behavior and may cause the system to hang.

Workaround: For systems that use the FLUSH# input signal and Deep Sleep state of the processor, ensure that FLUSH# is not asserted while STPCLK# is asserted.

Status: For the steppings affected see the *Summary of Changes* at the beginning of this section.

E61. Intermittent Failure to Assert ADS# During Processor Power-On

Problem: Under a system specific set of initial parametric conditions, a very small number of Pentium® III processors (CPUID 068xh) may be susceptible to entering an internal test mode during processor power-on. The symptom of this test mode is a failure to assert ADS# during a processor power-on.

Implication: On susceptible platforms, when power is applied to the processor, there is a possibility that the processor will occasionally enter the test mode rather than initiate a system boot sequence.

Workaround: A subsequent processor Power-Off then Power-On cycle should remove the processor from this test mode, allowing normal processor operation to resume. The following workaround also may reduce the occurrence of the failure condition:

SC242-based platform designs in which VTT leads the processor input voltage may reduce the occurrence of the erratum by connecting SC242 pin B20 (RESERVED) to pin B9 (VTT).

PGA370-based platform designs in which VTT leads the processor input voltage can reduce the occurrence of the erratum by connecting pin G37 (RESERVED) to motherboard VTT or short the PGA370 socket pin G37 to AH20 or G35 (both VTT).

Status: For the steppings affected see the *Summary of Changes* at the beginning of this section.

E62. Floating-Point Exception Condition May be Deferred

Problem: A floating-point instruction that causes a pending floating-point exception (ES=1) is normally signaled by the processor on the next waiting FP/MMX™ technology instruction. In the following set of circumstances, the exception may be delayed or the FSW register may contain a wrong value:

1. The excepting floating-point instruction is followed by an instruction that accesses memory across a page (4-Kbyte) boundary or its access results in the update of a page table dirty/access bit.
2. The memory accessing instruction is immediately followed by a waiting floating-point or MMX technology instruction.
3. The waiting floating-point or MMX technology instruction retires during a one-cycle window that coincides with a sequence of internal events related to instruction cache line eviction.

Implication: The floating-point exception will not be signaled until the next waiting floating-point/MMX technology instruction. Alternatively it may be signaled with the wrong TOS and condition code values. This erratum has not been observed in any commercial software applications.

Workaround: None identified

Status: For the stepping affected see the Summary of Changes at the beginning of this section.

E63. THERMTRIP# May Not be Asserted as Specified

Problem: THERMTRIP# is a signal on the Pentium® III processor that is asserted when the core reaches a critical temperature during operation as detailed in the processor specification. The Pentium® III processor may not assert THERMTRIP# until a much higher temperature than the one specified is reached.

Implication: The THERMTRIP# feature is not functional on the Pentium® III processor. Note that this erratum can only occur when the processor is running with a TPLATE temperature over the maximum specification of 75° C.

Workaround: Avoid operation of the Pentium III processor outside of the thermal specifications defined by the processor specifications.

Status: For the steppings affected see the *Summary of Changes* at the beginning of this section.

E64. Cache Line Reads May Result in Eviction of Invalid Data

Problem: A small window of time exists in which internal timing conditions in the processor cache logic may result in the eviction of an L2 cache line marked in the invalid state.

Implication: There are three possible implications of this erratum:

1. The processor may provide incorrect L2 cache line data by evicting an invalid line.
2. A BNR# (Block Next Request) stall may occur on the system bus.
3. Should a snoop request occur to the same cache line in a small window of time the processor may incorrectly assert HITM#. It is then possible for an infinite snoop stall to occur should another processor respond (correctly) to the snoop request with HIT#. In order for this infinite snoop stall to occur, at least three agents must be present, and the probability of occurrence increases with the number of processors. Should 2 or 3 occur, the processor will eventually assert BINIT# (if enabled) with an MCA error code indicating a ROB time-out. At this point, the system requires a hard reset.

Workaround: It is possible for BIOS code to contain a workaround for this erratum.

Status: For the steppings affected see the *Summary of Changes* at the beginning of this section.

E65. Snoop probe during FLUSH# could cause L2 to be left in shared state

Problem: During a L2 FLUSH operation using the FLUSH# pin, it is possible that a read request from a bus agent or other processor to a valid line will leave the line in the Shared state (S) instead of the Invalid state (I) as expected after flush operation. Before the FLUSH operation is completed, another snoop request to invalidate the line from another agent or processor could be ignored, again leaving the line in the Shared state.

Implication: Current desktop and mid range server systems have no mechanism to assert the flush pin and hence are not affected by this erratum. A high-end server system that does not suppress snoop traffic before the assertion of the FLUSH# pin may cause a line to be left in an incorrect cache state.

Workaround: Affected systems (those capable of asserting the FLUSH# pin) should prevent snoop activity on the front side bus until invalidation is completed after asserting FLUSH#, or use a WBINVD instruction instead of asserting the FLUSH# pin in order to flush the cache.

Status: For the steppings affected see the *Summary of Changes* at the beginning of this section.

E66. Livelock May Occur Due to IFU Line Eviction

Problem: Following the conditions outlined for erratum E44, if the instruction that is currently being executed from the evicted line must be restarted by the IFU, and the IFU receives another partial hit on a previously executed (but not as yet completed) store that is resident in the store buffer, then a livelock may occur.

Implication: If this erratum occurs, the processor will hang in a live lock-situation, and the system will require a reset to continue normal operation.

Workaround: None identified

Status: For the steppings affected see the *Summary of Changes* at the beginning of this section.

E67. Selector for the LTR/LLDT Register May Get Corrupted

Problem: The internal selector portion of the respective register (TR, LDTR) may get corrupted, if during a small window of LTR or LLDT system instruction execution, the following sequence of events occur:

1. Speculative write to a segment register that might follow the LTR or LLDT instruction
2. The read segment descriptor of LTR/LLDT operation spans a page (4 Kbytes) boundary; or causes a page fault

Implication: Incorrect selector for LTR, LLDT instruction could be used after a task switch.

Workaround: Software can insert a serializing instruction between the LTR or LLDT instruction and the segment register write.

Status: For the steppings affected see the *Summary of Changes* at the beginning of this section.

E68. INIT Does Not Clear Global Entries in the TLB

Problem: INIT may not flush a TLB entry when:

1. The processor is in protected mode with paging enabled and the page global enable flag is set (PGE bit of CR4 register)
2. G bit for the page table entry is set
3. TLB entry is present in TLB when INIT occurs

Implication: Software may encounter unexpected page fault or incorrect address translation due to a TLB entry erroneously left in TLB after INIT.

Workaround: Write to CR3, CR4 or CR0 registers before writing to memory early in BIOS code to clear all the global entries from TLB.

Status: For the steppings affected see the *Summary of Changes* at the beginning of this section.

E69. VM Bit will be Cleared on a Double Fault Handler

Problem: Following a task switch to a Double Fault Handler that was initiated while the processor was in virtual-8086 (VM86) mode, the VM bit will be incorrectly cleared in EFLAGS.

Implication: When the OS recovers from the double fault handler, the processor will no longer be in VM86 mode.

Workaround: None identified

Status: For the steppings affected see the *Summary of Errata* at the beginning of this section.



E70. Memory Aliasing with Inconsistent A and D Bits may Cause Processor Deadlock

Problem: In the event that software implements memory aliasing by having two Page Directory Entries (PDEs) point to a common Page Table Entry (PTE) and the Accessed and Dirty bits for the two PDEs are allowed to become inconsistent the processor may become deadlocked.

Implication: This erratum has not been observed with commercially available software.

Workaround: Software that needs to implement memory aliasing in this way should manage the consistency of the Accessed and Dirty bits.

Status: For the steppings affected see the *Summary of Changes* at the beginning of this section.

E71. Use of Memory Aliasing with Inconsistent Memory Type May Cause System Hang

Problem: Software that implements memory aliasing by having more than one linear addresses mapped to the same physical page with different cache types may cause the system to hang. This would occur if one of the addresses is non-cacheable used in code segment and the other a cacheable address. If the cacheable address finds its way in instruction cache, and non-cacheable address is fetched in IFU, the processor may invalidate the non-cacheable address from the fetch unit. Any micro-architectural event that causes instruction restart will expect this instruction to still be in fetch unit and lack of it will cause system hang.

Implication: This erratum has not been observed with commercially available software.

Workaround: Although it is possible to have a single physical page mapped by two different linear addresses with different memory types, Intel has strongly discouraged this practice as it may lead to undefined results. Software that needs to implement memory aliasing should manage the memory type consistency.

Status: For the steppings affected see the *Summary of Changes* at the beginning of this section.

E72. Processor may Report Invalid TSS Fault Instead of Double Fault During Mode C Paging

Problem: When an operating system executes a task switch via a Task State Segment (TSS) the CR3 register is always updated from the new task TSS. In the mode C paging, once the CR3 is changed the processor will attempt to load the PDPTRs. If the CR3 from the target task TSS or task switch handler TSS is not valid then the new PDPTR will not be loaded. This will lead to the reporting of invalid TSS fault instead of the expected Double fault.

Implication: Operating systems that access an invalid TSS may get invalid TSS fault instead of a Double fault.

Workaround: Software needs to ensure any accessed TSS is valid.

Status: For the steppings affected see the *Summary of Changes* at the beginning of this section.

E73. Machine Check Exception May Occur When Interleaving Code Between Different Memory Types

Problem: A small window of opportunity exists where code fetches interleaved between different memory types may cause a machine check exception. A complex set of micro-architectural boundary conditions is required to expose this window.

Implication: Interleaved instruction fetches between different memory types may result in a machine check exception. The system may hang if machine check exceptions are disabled. Intel has not observed the occurrence of this erratum while running commercially available applications or operating systems.

Workaround: Software can avoid this erratum by placing a serializing instruction between code fetches between different memory types.

Status: For the steppings affected see the *Summary of Changes* at the beginning of this section.

E74. Wrong ESP Register Values During a Fault in VM86 Mode

Problem: At the beginning of the IRET instruction execution in VM86 mode, the lower 16 bits of the ESP register are saved as the old stack value. When a fault occurs, these 16 bits are moved into the 32-bit ESP, effectively clearing the upper 16 bits of the ESP.

Implication: This erratum has not been observed to cause any problems with commercially available software.

Workaround: None identified

Status: For the steppings affected see the *Summary of Changes* at the beginning of this section.

E75. APIC ICR Write May Cause Interrupt Not to be Sent When ICR Delivery Bit Pending

Problem: If the APIC ICR (Interrupt Control Register) is written with a new interrupt command while the Delivery Status bit from a previous interrupt command is set to '1' (Send Pending), the interrupt message may not be sent out by the processor.

Implication: This erratum will cause an interrupt message not to be sent, potentially resulting in system hang.

Workaround: Software should always poll the Delivery Status bit in the APIC ICR and ensure that it is '0' (Idle) before writing a new value to the ICR.

Status: For the steppings affected see the *Summary of Changes* at the beginning of this section.

E76. High Temperature and Low Supply Voltage Operation May Result in Incorrect Processor Operation

Problem: When operating at the high temperature, low supply voltage corner of the processor specification, if there is a store pending in the processor's fill buffer, and simultaneously a load operation misses the L1 cache but results in a hit to the L2 cache, then it is possible that incorrect data may be returned to satisfy the load operation.



Implication: When this erratum is encountered, unpredictable software behavior may occur. It can be seen from the table of affected steppings that this erratum is constrained to a single stepping and is only possible in processors operating at frequencies of 933MHz and above and is not present in all of those processors. Application of the workaround will prevent occurrence of the erratum in all processors of that stepping.

Workaround: It is possible for BIOS code to contain a workaround for this erratum.

Status: For the steppings affected see the *Summary of Changes* at the beginning of this section.

E77. During Boundary Scan, BCLK not Sampled High When SLP# is Asserted Low

Problem: During boundary scan, BCLK is not sampled high when SLP# is asserted low.

Implication: Boundary scan results may be incorrect when SLP# is asserted low.

Workaround: Do not use boundary scan when SLP# is asserted low.

Status: For the steppings affected see the *Summary of Changes* at the beginning of this section.

E78. Incorrect Assertion of THERMTRIP# Signal

Problem: The internal control register bit responsible for operation of the Thermtrip circuit functionality may power up in a non-initialized state. As a result, THERMTRIP# may be incorrectly asserted during de-assertion of RESET# at nominal operating temperatures. When THERMTRIP# is asserted as a result of this erratum, the processor may shut down internally and stop execution but in few cases continue to execute.

Implication: This issue can lead to intermittent system power-on boot failures. The occurrence and repeatability of failures is system dependent, however all systems and processors are susceptible to failure. In addition, the processor may fail to stop execution during the event of a valid THERMTRIP# assertion resulting in the potential for permanent processor damage.

Workaround: To prevent the risk of power-on boot failures or catastrophic thermal failures, a platform workaround is required. The system must provide a rising edge on the TCK signal during the power-on sequence that meets all of the following requirements:

- Rising edge occurs after Vcc_core is valid and stable
- Rising edge occurs before or at the de-assertion of RESET#
- Rising edge occurs after all Vref input signals are at valid voltage levels
- TCK input meets the Vih min and max spec as mentioned in EMTS

Specific workaround implementations may be platform specific. The following examples have been tested as acceptable workaround implementations.

In addition, the example workaround circuits shown do not support production baseboard test methodologies that require the use of the processor JTAG/TAP port. Alternative workaround solutions must be found if such test capability is required.

Pentium® III Processor with 512KB L2 Cache Platforms Workaround

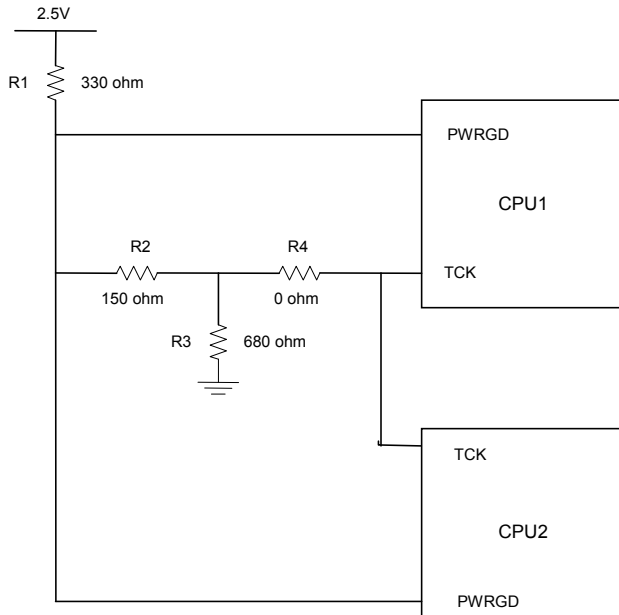

Assumes the inputs to the CPU_PWRGD are open collector signals that are Wire-ANDed together

- The example workaround circuit assumes that the PWRGD inputs into the processors are open collector. Tying the PWRGD inputs together in a Wired-AND fashion allows each processor to receive PWRGD at the same time but at the latter of the 2 separate PWRGD assertions. If separation of the PWRGD inputs to each processor is required, extra circuitry will be required.

Status: For the steppings affected see the *Summary of Changes* at the beginning of this section.

E79. Processor Might not Exit Sleep State Properly Upon De-assertion of CPUSLP# Signal

Problem: If the processor enters a sleep state upon assertion of CPUSLP# signal, and if the core to system bus multiplier is an odd bus fraction, then the processor may not resume from the CPU sleep state upon the de-assertion of CPUSLP# signal.

Implication: This erratum may result in a system hang during a resume from CPU sleep state.

Workaround: It is possible to workaround this in BIOS by not asserting CPUSLP# for power management purposes

Status: For the steppings affected see the *Summary of Changes* at the beginning of this section.

E80. *The Instruction Fetch Unit (IFU) May Fetch Instructions Based Upon Stale CR3 Data after a Write to CR3 Register*

Problem: Under a complex set of conditions, there exists a one-clock window following a write to the CR3 register wherein it is possible for the iTLB fill buffer to obtain a stale page translation based on the stale CR3 data. This stale translation will persist until the next write to the CR3 register, the next page fault or execution of a certain class of instructions including CPUID or IRETD with privilege level change.

Implication: The wrong page translation could be used leading to erroneous software behavior.

Workaround: Operating systems that are potentially affected can add a second write to the CR3 register.

Status: For the steppings affected see the *Summary of Changes* at the beginning of this section.

E81. *Under Some Complex Conditions, the Instructions in the Shadow of a JMP FAR may be Unintentionally Executed and Retired*

Problem: If all of the following events happen in sequence it is possible for the system or application to hang or to execute with incorrect data.

1. The execution of an instruction, with an OPCODE that requires the processor to stall the issue of micro-instructions in the flow from the microcode sequence logic block to the instruction decode block. (a StallMS condition)
2. Less than 63 (39 for Pre-CPUID 0x6BX) micro-instructions later, the execution of a mispredictable branch instruction. (Jcc, LOOPcc, RET Near, CALL Near Indirect, JMP ECX=0, or JMP Near Indirect)
3. The conditional branch in event (2) is mispredicted, and furthermore the mispredicted path of execution must result in either an ITLB miss, or an Instruction Cache miss. This needs to briefly stall the issue of micro-instructions again immediately after the conditional branch until that branch prediction is corrected by the jump execution block. (a 2nd StallMS condition)
4. Along the correct path of execution, the next instruction must contain a 3rd StallMS condition at a precisely aligned point in the execution of the instruction. (CLTS, POPSS, LSS, or MOV to SS)
5. A JMP FAR instruction must execute within the next 63 micro-instructions (39 Pre-CPUID 0x6BX) The intervening micro-instructions must not have any events or faults.

When the instruction from event (2) retires, the StallMS condition within the event (5) instruction fails to operate correctly, and instructions in the shadow of the JMP FAR instruction could be unintentionally executed.

Implication: Occurrence of this erratum could lead to erroneous software behavior. Intel has not identified any commercially available software which may encounter this condition; this erratum was discovered in a focused test environment. One of the four instructions that are required to trigger this erratum, CLTS, is a privileged instruction that is only executed by an operating system or driver code. The remaining three instructions, POPSS, LSS, and MOV to SS, are executed infrequently in modern 32-bit application code.

Workaround: None identified at this time

Status: For the steppings affected see the *Summary of Changes* at the beginning of this section.



E82 Processor Does not Flag #GP on Non-zero Write to Certain MSRs

Problem: When a non-zero write occurs to the upper 32 bits of SYSENTER_EIP_MSR or SYSENTER_ESP_MSR, the processor should indicate a general protection fault by flagging #GP. Due to this erratum, the processor does not flag #GP.

Implication: The processor unexpectedly does not flag #GP on a non-zero write to the upper 32 bits of SYSENTER_EIP_MSR or SYSENTER_ESP_MSR. No known commercially available operating system has been identified to be affected by this erratum.

Workaround: None identified.

Status: For the steppings affected see the *Summary of Changes* at the beginning of this section.

E83. IFU/BSU Deadlock May Cause System Hang

Problem: A lockable instruction with memory operand that spans across two pages may, given some rare internal conditions, hang the system.

Implication: When this erratum occurs, the system may hang. Intel has not observed this erratum with any commercially available software or system.

Workaround: Lockable data should always be contained in a single page.

Status: For the steppings affected see the *Summary of Changes* at the beginning of this section.

E84. REP MOVSB Operation in Fast String Mode Continues in That Mode When Crossing into a Page with a Different Memory Type

Problem: A fast “REP MOVSB” operation will continue to be handled in fast mode when the string operation crosses a page boundary into an Uncacheable (UC) memory type. Also if the fast string operation crosses a page boundary into a WC memory region, the processor will not self snoop the WC memory region. This may eventually result in incorrect data for the WC portion of the operation if those cache lines were previously cached as WB (through aliasing) and modified.

Implication: String elements should be handled by the processor at the native operand size in UC memory. In the event that the WB to WC aliasing case occurs and incorrect data is written to memory, the end result would vary from benign to operating system or application failure. Intel has not observed either aspects of this erratum in commercially available software.

Workaround: Software operating within Intel’s recommendation will not require WB and WC memory aliased to the same physical address.

Status: For the steppings affected, see the *Summary Table of Changes*.

E85. The FXSAVE, STOS or MOVS Instructions May Cause a Store Ordering Violation When Data Crosses a Page with a UC Memory Type

Problem: If the data from an FXSAVE, STOS or MOVS instruction crosses a page boundary from WB to UC memory type and this instruction is immediately followed by a second instruction that also issues a store to memory, the final data stores from both instructions may occur in the wrong order.

Implication: The impact of this store ordering behavior may vary from normal software execution to potential software failure. Intel has not observed this erratum in commercially available software.

Workaround: FXSAVE, STOS or MOVS data must not cross page boundary from WB to UC memory type.

Status: For the steppings affected, see the *Summary Table of Changes*.

E86. POPF and POPFD Instructions that Set the Trap Flag Bit May Cause Unpredictable Processor Behavior

Problem: In some rare cases, POPF and POPFD instructions that set the Trap Flag (TF) bit in the EFLAGS register (causing the processor to enter Single-Step mode) may cause unpredictable processor behavior.

Implication: Single step operation is typically enabled during software debug activities, not during normal system operation.

Workaround: There is no workaround for single step operation in commercially available software. For debug activities on custom software, the POPF and POPFD instructions could be immediately followed by a NOP instruction to facilitate correct execution.

Status: For the steppings affected, see the *Summary Table of Changes*.

E87. Code Segment Limit Violation May Occur on 4 Gigabyte Limit Check

Problem: Code Segment limit violation may occur on 4 Gigabyte limit check when the code stream wraps around in a way that one instruction ends at the last byte of the segment and the next instruction begins at 0x0.

Implication: This is a rare condition that may result in a system hang. Intel has not observed this erratum with any commercially available software, or system.

Workaround: Avoid code that wraps around segment limit.

Status: For the steppings affected, see the *Summary Table of Changes*.



E88. *FST Instruction with Numeric and Null Segment Exceptions May Cause General Protection Faults to be Missed and FP Linear Address (FLA) Mismatch*

Problem: FST instruction combined with numeric and null segment exceptions may cause General Protection Faults to be missed and FP Linear Address (FLA) mismatch.

Implication: This is a rare condition that may result in a system hang. Intel has not observed this erratum with any commercially available software, or system.

Workaround: None identified.

Status: For the steppings affected, see the *Summary Table of Changes*.

E89. *Code Segment (CS) is incorrect on SMM Handler when SMBASE is not Aligned*

Problem: With SMBASE being relocated to a non-aligned address, during SMM entry the CS can be improperly updated which can lead to an incorrect SMM handler.

Implication: This is a rare condition that may result in a system hang. Intel has not observed this erratum with any commercially available software, or system.

Workaround: Align SMBASE to 32K byte.

Status: For the steppings affected, see the *Summary Table of Changes*.

E90. *Page with PAT (Page Attribute Table) Set to USWC (Uncacheable Speculative Write Combine) While Associated MTRR (Memory Type Range Register) is UC (Uncacheable) May Consolidate to UC*

Problem: A page whose PAT memory type is USWC while the relevant MTRR memory type is UC, the consolidated memory type may be treated as UC (rather than WC as specified in IA-32 Intel® Architecture Software Developer's Manual).

Implication: When this erratum occurs, the memory page may be as UC (rather than WC). This may have a negative performance impact.

Workaround: None identified.

Status: For the steppings affected, see the *Summary Table of Changes*.

E91. Under Certain Conditions LTR (Load Task Register) Instruction May Result in System Hang

Problem: An LTR instruction may result in a system hang if all the following conditions are met:

1. Invalid data selector of the TR (Task Register) resulting with either #GP (General Protection Fault) or #NP (Segment Not Present Fault).
2. GDT (Global Descriptor Table) is not 8-Bytes aligned. GDT (Global Descriptor Table) is not 8-Bytes aligned.
3. Data BP (breakpoint) is set on cache line containing the descriptor data.

Implication: This erratum may result in system hang if all conditions have been met. This erratum has not been observed in commercial operating systems or software. For performance reasons, GDT is typically aligned to 8-Bytes.

Workaround: Software should align GDT to 8-Bytes.

Status: For the steppings affected, see the *Summary Table of Changes*.

E92. Loading from Memory Type USWC (Uncacheable Speculative Write Combine) May Get Its Data Internally Forwarded From a Previous Pending Store

Problem: A load from memory type USWC may get its data internally forwarded from a pending store. As a result, the expected load may never be issued to the external bus.

Implication: When this erratum occurs, a USWC Load request may be satisfied without being observed on the external bus. There are no known usage models where this behavior results in any negative side-effects.

Workaround: Do not use memory type USWC for memory that has read side effects.

Status: For the steppings affected, see the *Summary Table of Changes*.

E93. FXSAVE after FNINIT Without an Intervening FP (Floating Point) Instruction May Save Uninitialized Values for FDP (x87 FPU Instruction Operand (Data) Pointer Offset) and FDS (x87 FPU Instruction Operand (Data) Pointer Selector)

Problem: An FXSAVE after FNINIT without an intervening FP instruction may save uninitialized values for FDP and FDS.

Implication: When this erratum occurs, the values for FDP/FDS in the FXSAVE structure may appear to be random values. These values will be initialized by the first FP instruction executed after the FXRSTOR that restore the saved floating point state. Any FP instruction with memory operand will initialize FDP/FDS. Intel has not observed this erratum with any commercially available software.

Workaround: After an FNINIT, do not expect the FXSAVE memory image to be correct, until at least one FP instruction with a memory operand has been executed.

Status: For the steppings affected, see the *Summary Table of Changes*.



E94. FSTP (Floating Point Store) Instruction Under Certain Conditions May Result In Erroneously Setting a Valid Bit on an FP (Floating Point) Stack Register

Problem: An FSTP instruction with an PDE/PTE (Page Directory Entry/Page Table Entry) A/D bit update followed by user mode access fault due to a code fetch to a page that has supervisor only access permission may result in erroneously setting a valid bit of an FP stack register. The FP top of stack pointer is unchanged.

Implication: This erratum may cause an unexpected stack overflow.

Workaround: User mode code should not count on being able to recover from illegal accesses to memory regions protected with supervisor only access when using FP instructions.

Status: For the steppings affected, see the *Summary Table of Changes*.

E95. Invalid Entries in Page-Directory-Pointer-Table Register (PDPTR) May Cause General Protection (#GP) Exception if the Reserved Bits are Set to One

Problem: Invalid entries in the Page-Directory-Pointer-Table Register (PDPTR) that have the reserved bits set to one may cause a General Protection (#GP) exception.

Implication: Intel has not observed this erratum with any commercially available software.

Workaround: Do not set the reserved bits to one when PDPTR entries are invalid.

Status: For the steppings affected see the *Summary of Changes* at the beginning of this section.

E96. Writing the Local Vector Table (LVT) when an Interrupt is Pending May Cause an Unexpected Interrupt

Problem: If a local interrupt is pending when the LVT entry is written, an interrupt may be taken on the new interrupt vector even if the mask bit is set.

Implication: An interrupt may immediately be generated with the new vector when a LVT entry is written, even if the new LVT entry has the mask bit set. If there is no Interrupt Service Routine (ISR) set up for that vector the system will GP fault. If the ISR does not do an End of Interrupt (EOI) the bit for the vector will be left set in the in-service register and mask all interrupts at the same or lower priority.

Workaround: Any vector programmed into an LVT entry must have an ISR associated with it, even if that vector was programmed as masked. This ISR routine must do an EOI to clear any unexpected interrupts that may occur. The ISR associated with the spurious vector does not generate an EOI, therefore the spurious vector should not be used when writing the LVT.

Status: For the steppings affected, see the Summary Tables of Changes.

E97. The Processor May Report a #TS Instead of a #GP Fault

Problem: A jump to a busy TSS (Task-State Segment) may cause a #TS (invalid TSS exception) instead of a #GP fault (general protection exception).

Implication: Operation systems that access a busy TSS may get invalid TSS fault instead of a #GP fault. Intel has not observed this erratum with any commercially available software.

Workaround: None identified.

Status: For the steppings affected, see the Summary Tables of Changes.

E98. A Write to an APIC Register Sometimes May Appear to Have Not Occurred

Problem: With respect to the retirement of instructions, stores to the uncacheable memory-based APIC register space are handled in a non-synchronized way. For example if an instruction that masks the interrupt flag, e.g. CLI, is executed soon after an uncacheable write to the Task Priority Register (TPR) that lowers the APIC priority, the interrupt masking operation may take effect before the actual priority has been lowered. This may cause interrupts whose priority is lower than the initial TPR, but higher than the final TPR, to not be serviced until the interrupt enabled flag is finally set, i.e. by STI instruction. Interrupts will remain pending and are not lost.

Implication: In this example the processor may allow interrupts to be accepted but may delay their service.

Workaround: This non-synchronization can be avoided by issuing an APIC register read after the APIC register write. This will force the store to the APIC register before any subsequent instructions are executed. No commercial operating system is known to be impacted by this erratum..

Status: For the steppings affected, see the Summary Tables of Changes.

E99. Using 2M/4M Pages When A20M# Is Asserted May Result in Incorrect Address Translations

Problem: An external A20M# pin if enabled forces address bit 20 to be masked (forced to zero) to emulate real-address mode address wraparound at 1 megabyte. However, if all of the following conditions are met, address bit 20 may not be masked.

- paging is enabled
- a linear address has bit 20 set
- the address references a large page



- A20M# is enabled

Implication: When A20M# is enabled and an address references a large page the resulting translated physical address may be incorrect. This erratum has not been observed with any commercially available operating system.

Workaround: Operating systems should not allow A20M# to be enabled if the masking of address bit 20 could be applied to an address that references a large page. A20M# is normally only used with the first megabyte of memory.

Status: For the steppings affected, see the Summary Tables of Change.

E100. Values for LBR/BTS/BTM will be Incorrect after an Exit from SMM

Problem: After a return from SMM (System Management Mode), the CPU will incorrectly update the LBR (Last Branch Record) and the BTS (Branch Trace Store), hence rendering their data invalid. The corresponding data if sent out as a BTM on the system bus will also be incorrect. Note: This issue would only occur when one of the 3 above mentioned debug support facilities are used.

Implication: The value of the LBR, BTS, and BTM immediately after an RSM operation should not be used.

Workaround: None identified.

Status: For the steppings affected, see the Summary Tables of Change.

E101. INIT Does Not Clear Global Entries in the TLB

Problem: INIT may not flush a TLB entry when:

1. The processor is in protected mode with paging enabled and the page global enable flag is set (PGE bit of CR4 register)
2. G bit for the page table entry is set
3. TLB entry is present in TLB when INIT occurs.

Implication: Software may encounter unexpected page fault or incorrect address translation due to a TLB entry erroneously left in TLB after INIT.

Workaround: Write to CR3, CR4 (setting bits PSE, PGE or PAE) or CR0 (setting bits PG or PE) registers before writing to memory early in BIOS code to clear all the global entries from TLB.

Status: For the steppings affected, see the Summary Table of Changes.

E102. REP MOVS/STOS Executing with Fast Strings Enabled and Crossing Page Boundaries with Inconsistent Memory Types may use an Incorrect Data Size or Lead to Memory-Ordering Violations

Problem: Under certain conditions as described in the Software Developers Manual section “Out-of-Order Stores For String Operations in Pentium 4, Intel Xeon, and P6 Family Processors” the processor performs REP MOVS or REP STOS as fast strings. Due to this erratum fast string REP MOVS/REP STOS instructions that cross page boundaries from WB/WC memory types to UC/WP/WT memory types, may start using an incorrect data size or may observe memory ordering violations.

Implication: Upon crossing the page boundary the following may occur, dependent on the new page memory type:

- UC the data size of each write will now always be 8 bytes, as opposed to the original data size.
- WP the data size of each write will now always be 8 bytes, as opposed to the original data size and there may be a memory ordering violation.
- WT there may be a memory ordering violation.

Workaround: Software should avoid crossing page boundaries from WB or WC memory type to UC, WP or WT memory type within a single REP MOVS or REP STOS instruction that will execute with fast strings enabled.

Status: For the steppings affected, see the Summary Tables of Changes

E103. The BS Flag in DR6 May be Set for Non-Single-Step #DB Exception

Problem: DR6 BS (Single Step, bit 14) flag may be incorrectly set when the TF (Trap Flag, bit 8) of the EFLAGS Register is set, and a #DB (Debug Exception) occurs due to one of the following:

- DR7 GD (General Detect, bit 13) being bit set;
- INT1 instruction;
- Code breakpoint

the DR6 BS (Single Step, bit 14) flag may be incorrectly set.

Implication: The BS flag may be incorrectly set for non-single-step #DB exception.

Workaround: None identified.

Status: For the steppings affected, see the Summary Tables of Changes

E104. Fault on ENTER Instruction May Result in Unexpected Values on Stack Frame

Problem: The ENTER instruction is used to create a procedure stack frame. Due to this erratum, if execution of the ENTER instruction results in a fault, the dynamic storage area of the resultant stack frame may contain unexpected values (i.e. residual stack data as a result of processing the fault).

Implication: Data in the created stack frame may be altered following a fault on the ENTER instruction. Please refer to "Procedure Calls For Block-Structured Languages" in IA-32 Intel® Architecture Software Developer's Manual, Vol. 1, Basic Architecture, for information on the usage of the ENTER instructions. This erratum is not expected to occur in ring 3. Faults are usually processed in ring 0 and stack switch occurs when transferring to ring 0. Intel has not observed this erratum on any commercially available software.

Workaround: None identified.

Status: For the steppings affected, see the Summary Tables of Changes

E105. Unaligned Accesses to Paging Structures May Cause the Processor to Hang

Problem: when an unaligned access is performed on paging structure entries, accessing a portion of two different entries simultaneously, the processor may live lock.

Implication: When this erratum occurs, the processor may live lock causing a system hang.

Workaround: Do not perform unaligned accesses on paging structure entries.

Status: For the steppings affected see the *Summary of Changes* at the beginning of this section.

E106. INVLPG Operation for Large (2M/4M) Pages May be Incomplete under Certain Conditions

Problem: The INVLPG instruction may not completely invalidate Translation Look-aside Buffer (TLB) entries for large pages (2M/4M) when both of the following conditions exist:

- Address range of the page being invalidated spans several Memory Type Range Registers (MTRRs) with different memory types specified
- INVLPG operation is preceded by a Page Assist Event (Page Fault (#PF) or an access that results in either A or D bits being set in a Page Table Entry (PTE))

Implication: Stale translations may remain valid in TLB after a PTE update resulting in unpredictable system behavior. Intel has not observed this erratum with any commercially available software.

Workaround: Software should ensure that the memory type specified in the MTRRs is the same for the entire address range of the large page.

Status: For the steppings affected see the *Summary of Changes* at the beginning of this section.

E107. Page Access Bit May be Set Prior to Signaling a Code Segment Limit Fault

Problem: If code segment limit is set close to the end of a code page, then due to this erratum the memory page Access bit (A bit) may be set for the subsequent page prior to general protection fault on code segment limit.

Implication: When this erratum occurs, a non-accessed page which is present in memory and follows a page that contains the code segment limit may be tagged as accessed.

Workaround: Erratum can be avoided by placing a guard page (non-present or non-executable page) as the last page of the segment or after the page that includes the code segment limit.

Status: For the steppings affected see the *Summary of Changes* at the beginning of this section.

E108. EFLAGS, CR0, CR4 and the EXF4 Signal May be Incorrect after Shutdown

Problem: When the processor is going into shutdown due to an RSM inconsistency failure, EFLAGS, CR0 and CR4 may be incorrect. In addition the EXF4 signal may still be asserted. This may be observed if the processor is taken out of shutdown by NMI#.

Implication: A processor that has been taken out of shutdown may have an incorrect EFLAGS, CR0 and CR4. In addition the EXF4 signal may still be asserted.

Workaround: None identified.

Status: For the steppings affected see the *Summary of Changes* at the beginning of this section.

E109. Performance Monitoring Event FP_MMX_TRANS_TO_MMX May Not Count Some Transitions

Problem: Performance Monitor Event FP_MMX_TRANS_TO_MMX (Event CCH, Umask 01H) counts transitions from x87 Floating Point (FP) to MMX™ instructions. Due to this erratum, if only a small number of MMX instructions (including EMMS) are executed immediately after the last FP instruction, an FP to MMX transition may not be counted.

Implication: The count value for Performance Monitoring Event FP_MMX_TRANS_TO_MMX may be lower than expected. The degree of undercounting is dependent on the occurrences of the erratum condition while the counter is active. Intel has not observed this erratum with any commercially available software.



Workaround: None identified.

Status: For the steppings affected see the *Summary of Changes* at the beginning of this section.



DOCUMENTATION CHANGES

The Documentation Changes listed in this section apply to the following documents:

- *Pentium® III Processor for the SC242 at 450MHz to 1.13GHz datasheet*
- *Pentium® III Processor for the PGA370 Socket at 500MHz to 1.13 GHz datasheet*
- *Pentium® III Processor on 0.13 micron process datasheet*
- *Pentium® III Processor with 512KB L2 Cache datasheet*

All Documentation Changes will be incorporated into a future version of the appropriate Pentium III processor documentation.

Note: Documentation changes for Intel® 64 and IA-32 Architectures Software Developer's Manual volumes 1, 2a, 2b, 3a and 3b are posted in a separate document "Intel® 64 and IA-32 Architectures Software Developer's Manual Documentation Changes". This Document has been posted to <http://developer.intel.com/>.

There are no Documentation Changes for this Month



SPECIFICATION CLARIFICATIONS

The Specification Clarifications listed in this section apply to the following documents:

- *Pentium® III Processor for the SC242 at 450MHz to 1.13GHz datasheet*
- *Pentium® III Processor for the PGA370 Socket at 500MHz to 1.13 GHz datasheet*
- *Pentium® III Processor on 0.13 micron process Up to 1.40 GHz datasheet*
- *Pentium® III Processor with 512KB L2 Cache datasheet*
- *Intel® 64 and IA-32 Architectures Software Developer's Manual Volume 1, 2a, 2b, 3a and 3b: System Programming Guide*

All Specification Clarifications will be incorporated into a future version of the appropriate Pentium III processor documentation.

E1. Specification Clarification with respect to Time Stamp Counter

In the “Debugging and Performance Monitoring” chapter (Sections 15.8, 15.10.9 and 15.10.9.3) of the IA-32 Intel® Architecture Software Developer's Manual Volume 3: System Programming Guide, the Time Stamp Counter definition has been updated to include support for the future processors. This change will be incorporated in the next revision of the IA-32 Intel® Architecture Software Developer's Manual.

15.8 Time-Stamp Counter

The IA-32 architecture (beginning with the Pentium processor) defines a time-stamp counter mechanism that can be used to monitor and identify the relative time occurrence of processor events. The counter's architecture includes the following components:

- **TSC flag** — A feature bit that indicates the availability of the time-stamp counter. The counter is available in an IA-32 processor implementation if the function CPUID.1:EDX.TSC[bit 4] = 1.
- **IA32_TIME_STAMP_COUNTER MSR** (called TSC MSR in P6 family and Pentium processors) — The MSR used as the counter.
- **RDTSC instruction** — An instruction used to read the time-stamp counter.
- **TSD flag** — A control register flag is used to enable or disable the time-stamp counter (enabled if CR4.TSD[bit 2] = 1).

The time-stamp counter (as implemented in the P6 family, Pentium, Pentium M, Pentium 4, and Intel Xeon processors) is a 64-bit counter that is set to 0 following a RESET of the processor. Following a RESET, the counter will increment even when the processor is halted by the HLT instruction or the external STPCLK# pin. Note that the assertion of the external DPSLP# pin may cause the time-stamp counter to stop.

Members of the processor families increment the time-stamp counter differently:

- For Pentium M processors (family [06H], models [09H, 0DH]); for Pentium 4 processors, Intel Xeon processors (family [0FH], models [00H, 01H, or 02H]); and for P6 family processors: the time-stamp counter increments with every internal processor clock cycle. The internal processor clock cycle is determined by the current core-clock to bus-clock ratio. Intel® SpeedStep® technology transitions may also impact the processor clock.

- For Pentium 4 processors, Intel Xeon processors (family [0FH], models [03H and higher]): the time-stamp counter increments at a constant rate. That rate may be set by the maximum core-clock to bus-clock ratio of the processor or may be set by the frequency at which the processor is booted. The specific processor configuration determines the behavior. Constant TSC behavior ensures that the duration of each clock tick is uniform and supports the use of the TSC as a wall clock timer even if the processor core changes frequency. This is the architectural behavior moving forward.

NOTE

To determine average processor clock frequency, Intel recommends the use of Performance Monitoring logic to count processor core clocks over the period of time for which the average is required. See Section 15.10.9 and Appendix A in this manual for more information.

The RDTSC instruction reads the time-stamp counter and is guaranteed to return a monotonically increasing unique value whenever executed, except for a 64-bit counter wraparound. Intel guarantees that the time-stamp counter will not wraparound within 10 years after being reset. The period for counter wrap is longer for Pentium 4, Intel Xeon, P6 family, and Pentium processors.

Normally, the RDTSC instruction can be executed by programs and procedures running at any privilege level and in virtual-8086 mode. The TSD flag allows use of this instruction to be restricted to programs and procedures running at privilege level 0. A secure operating system would set the TSD flag during system initialization to disable user access to the time-stamp counter. An operating system that disables user access to the time-stamp counter should emulate the instruction through a user-accessible programming interface.

The RDTSC instruction is not serializing or ordered with other instructions. It does not necessarily wait until all previous instructions have been executed before reading the counter. Similarly, subsequent instructions may begin execution before the RDTSC instruction operation is performed.

The RDMSR and WRMSR instructions read and write the time-stamp counter, treating the time-stamp counter as an ordinary MSR (address 10H). In the Pentium 4, Intel Xeon, and P6 family processors, all 64-bits of the time-stamp counter are read using RDMSR (just as with RDTSC). When WRMSR is used to write the time-stamp counter on processors before family [0FH], models [03H, 04H]: only the low order 32-bits of the time-stamp counter can be written (the high-order 32 bits are cleared to 0). For family [0FH], models [03H, 04H]: all 64 bits are writeable.

15.10.9 Counting Clocks

The count of cycles, also known as clockticks, forms a the basis for measuring how long a program takes to execute. Clockticks are also used as part of efficiency ratios like cycles per instruction (CPI). Processor clocks may stop ticking under circumstances like the following:

- The processor is halted when there is nothing for the CPU to do. For example, the processor may halt to save power while the computer is servicing an I/O request. When Hyper-Threading Technology is enabled, both logical processors must be halted for performance-monitoring counters to be powered down.
- The processor is asleep as a result of being halted or because of a power-management scheme. There are different levels of sleep. In the some deep sleep levels, the time-stamp counter stops counting.

There are three ways to count processor clock cycles to monitor performance. These are:



- **Non-halted clockticks** — Measures clock cycles in which the specified logical processor is not halted and is not in any power-saving state. When Hyper-Threading Technology is enabled, these ticks can be measured on a per-logical-processor basis.
- **Non-sleep clockticks** — Measures clock cycles in which the specified physical processor is not in a sleep mode or in a power-saving state. These ticks cannot be measured on a logical-processor basis.
- **Time-stamp counter** — Some processor models permit clock cycles to be measured when the physical processor is not in deep sleep (by using the time-stamp counter and the RDTSC instruction). Note that such ticks cannot be measured on a per-logical-processor basis. See Section 10.8 for detail on processor capabilities.

The first two methods use performance counters and can be set up to cause an interrupt upon overflow (for sampling). They may also be useful where it is easier for a tool to read a performance counter than to use a time stamp counter (the timestamp counter is accessed using the RDTSC instruction).

For applications with a significant amount of I/O, there are two ratios of interest:

- **Non-halted CPI** — Non-halted clockticks/instructions retired measures the CPI for phases where the CPU was being used. This ratio can be measured on a logical-processor basis when Hyper-Threading Technology is enabled.
- **Nominal CPI** — Time-stamp counter ticks/instructions retired measures the CPI over the duration of a program, including those periods when the machine halts while waiting for I/O.

15.10.9.3 Incrementing the Time-Stamp Counter

The time-stamp counter increments when the clock signal on the system bus is active and when the sleep pin is not asserted. The counter value can be read with the RDTSC instruction.

The time-stamp counter and the non-sleep clockticks count may not agree in all cases and for all processors. See Section 10.8 for more information on counter operation.



SPECIFICATION CHANGES

The Specification Changes listed in this section apply to the following documents:

- *Intel® Pentium® III Processor for the SC242 at 450 MHz to 1.13 GHz datasheet*
- *Intel® Pentium® III Processor for the PGA370 Socket up to 1.13 GHz datasheet*
- *Intel® Pentium® III Processor on 0.13 Micron Process Up to 1.40 GHz Electrical, Mechanical and Thermal Specification*

All Specification Changes will be incorporated into a future version of the appropriate Pentium III processor documentation.

There are no Specification Changes for this Month